

20000831152

AD-A244 438

AD _____



2

FULL SCALE DEVELOPMENT AND INITIAL PRODUCTION OF THE
PERSONNEL/CASUALTY DECONTAMINATION SYSTEM
SKIN DECONTAMINATION KIT (PCDS SDK)

FINAL REPORT

NOAH BORENSTEIN
PRINCIPAL INVESTIGATOR

WRITTEN BY:

B.M. ROSENBAUM
J.E. SCHULFK
D.M. KEATING (PACO Pharmaceutical
Service services, Inc.)
S.D. ALEMI (FACC Pharmaceutical
Services, Inc.)

DTIC
ELECTE
JAN 9 1992
S B D

NOVEMBER 1991

Supported by

U.S. ARMY MEDICAL RESEARCH AND DEVELOPMENT COMMAND
Fort Detrick, Frederick, Maryland 21702-5012

Contract No. DAMD17-87-C-7116

Rohm and Haas Company
727 Harristown Road
Spring House, Pennsylvania 19477

Approved for public release; distribution unlimited.

The findings in this report are not to be construed as an
official Department of the Army position unless so designated
by other authorized documents

Reproduced From
Best Available Copy

92-00744

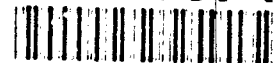

REPORT DOCUMENTATION PAGE

November 1991

Final

28 Apr 87 - 27 Jun 91

Full Scale Development and Initial Production of the
Personnel/Casualty Decontamination System Skin
Decontamination Kit (PCDS SDK)

DAMD17-87-C-7116

Noah Borenstein

PERFORMING ORGANIZATION NAME(S) AND ADDRESS(ES)

Rohm and Haas Company
727 Norristown Road
Spring House, Pennsylvania 19477

REPORT NUMBER

SPONSORING/MONITORING AGENCY NAME(S) AND ADDRESS(ES)

U.S. Army Medical Research & Development Command
Fort Detrick
Frederick, Maryland 21702-5012

SPONSORING/MONITORING AGENCY REPORT NUMBER

SUPPLEMENTARY NOTES

DISTRIBUTION STATEMENT IDENTIFICATION

DISTRIBUTION STATEMENT

ABSTRACT

14 SUBJECT TERMS

15 NUMBER OF PAGES

16 PRICE CODE

17 SECURITY CLASSIFICATION
OF REPORT

Unclassified

18 SECURITY CLASSIFICATION
OF THIS PAGE

Unclassified

19 SECURITY CLASSIFICATION
OF ABSTRACT

20 LIMITATION OF ABST

TABLE OF CONTENTS

| | |
|--|-----------|
| SUMMARY | 1 |
| A. SYSTEM DEVELOPMENT | 3 |
| 1. Kit Design | 3 |
| a. Foil Laminate Selection | 3 |
| b. Applicator Pad Development | 7 |
| c. Polyester Film Backing | 9 |
| d. Pouch | 9 |
| B. KIT MANUFACTURE | 10 |
| 1. Production of Initial 5,000 Prototype Kits | 10 |
| a. Handle Production | 10 |
| b. Applicator Pad Assembly | 10 |
| c. Pad/Handle Assembly | 11 |
| d. Packet Production | 11 |
| e. Resin Filling | 11 |
| f. Packet Loading | 12 |
| g. Packet Sealing/Lot Coding | 12 |
| h. Notching | 12 |
| i. Pouch Assembly | 15 |
| 2. Kit Manufacture Summary | 16 |
| a. Equipment/Tooling Suppliers | 16 |
| C. INSPECTION, TESTING AND EVALUATION | 21 |
| 1. Shelf-Life Studies | 21 |
| a. Percent Solids | 22 |
| b. Surface Area and Particle Size | 22 |
| c. Nonvolatile, Water Soluble Extractables | 22 |
| d. Vapor Desorption (CIS and DFP) | 23 |
| e. Liquid Sorption (Enslinn) | 23 |
| f. Sorptive Quality | 23 |
| g. Basicity | 24 |
| h. Acidity | 24 |
| i. Kydex® Sheet Surface Area Testing | 24 |
| j. Storage Stability Summary | 25 |
| 2. Photoallergy Test with Natural Sunlight | 37 |
| a. Summary | 37 |
| b. Results and Conclusions | 38 |
| 3. Repeated Insult Patch Test | 38 |
| a. Summary | 38 |
| b. Results and Conclusions | 38 |
| 4. Ambergardm XE-555 Resin Compatibility with Chemical Protective Masks | 39 |
| a. Summary | 39 |
| b. Details and Results | 39 |
| 5. NBC Survivability of the M291 Skin Decontaminating Kit | 42 |
| a. Background | 42 |
| b. Conclusions | 42 |
| 6. Packet Self-Decontamination | 43 |
| a. Summary | 43 |

TABLE OF CONTENTS (continued)

| | |
|--|-----------|
| 7. Resin Delivery Rate | 44 |
| a. Summary | 44 |
| 8. SDK Environmental Testing | 45 |
| Summary | 45 |
| D. KIT DESIGN IMPROVEMENTS | 47 |
| 1. Handle | 47 |
| 2. Center Heat Seal | 47 |
| 3. Polyback | 48 |
| 4. Overwrap Bag | 48 |
| E. SYSTEMS ENGINEERING | 49 |
| 1. Machinery | 49 |
| a. Filler Testing | 49 |
| b. Overwrapper/ Vacuum Packaging Machinery Manufacturers | 49 |
| 2. Packaging Requirements | 50 |
| a. Unit of Issue | 50 |
| F. TECHNICAL DATA PACKAGE | 51 |
| 1. Summary | 51 |
| 2. Purchase Description (EA-B-1657) | 51 |
| a. Destructive Testing | 52 |
| b. Examination | 53 |
| 3. Special Packaging Instructions (P5-77-2301) | 53 |
| 4. Drawings | 54 |
| 5. Operator's Manual | 55 |
| G. Leasehold Improvements | 55 |
| 1. Summary | 55 |
| H. Manufacturing System Installation | 57 |
| 1. Summary | 57 |
| I. MATERIALS DEVELOPMENT AND KIT DESIGN UPGRADE | 60 |
| 1. Summary | 60 |
| 2. Handle | 61 |
| 3. Polyback | 61 |
| 4. Pouch Material Alternatives | 62 |
| J. AMBERGARD IE-555 RESIN GRINDING | 62 |
| 1. Summary | 62 |
| 2. Grinding Campaign Using a 1.5 Gallon Mill | 63 |
| 3. 200 Gallon Mill with 3/16" Grinding Media & all-at-once Raw Material (RM) Addition | 63 |
| 4. Grinding Studies Utilizing a 30 Gallon Mill | 63 |
| 5. 30 Gallon Mill Production | 64 |
| 6. 200 Gallon Mill Production with New 1/4" Grinding Media | 64 |
| 7. 200 Gallon Mill Process Optimization | 64 |

TABLE OF CONTENTS (continued)

| | |
|---|----|
| K. PROCESS EQUIPMENT VALIDATION | 65 |
| 1. Summary | 65 |
| L. CONFIGURATIONAL MANAGEMENT PLAN (CMP) | 68 |
| 1. Summary | 68 |
| M. ENGINEERING CHANGE PROPOSALS (ECP's) | 73 |
| 1. Summary | 73 |
| N. SAFETY ENGINEERING | 74 |
| 1. Manufacturing Facilities | 74 |
| 2. Ambergard XE-555 Resin | 74 |
| O. PRODUCT ASSURANCE/QUALITY ASSURANCE PROGRAM PLAN | 75 |
| 1. Summary | 75 |
| 2. Material Specifications | 75 |
| 3. Quality Assurance Program Plan (QAPP) | 75 |
| P. FIRST ARTICLE INSPECTION PROCEDURE | 76 |
| 1. Summary | 76 |
| Q. FIRST ARTICLE INSPECTION REPORT | 76 |
| 1. Summary | 76 |
| 2. First Article Test-Paco Manufacturing Line # 1 | 76 |
| 3. First Article Test-Paco Manufacturing Line # 2 | 77 |
| R. ENVIRONMENTAL ASSESSMENT (EA) | 82 |
| 1. Summary | 82 |



| | |
|--------------------|-------------------------------------|
| Accession For | |
| NTIS GRA&I | <input checked="" type="checkbox"/> |
| DTIC TAB | <input type="checkbox"/> |
| Unannounced | <input type="checkbox"/> |
| Justification | <input type="checkbox"/> |
| By _____ | |
| Distribution/ | |
| Availability Codes | |
| Dist | Avail |
| A-1 | Special |

SUMMARY

Under this contract, designated "Full Scale Development and Initial Production of the Personnel/Casualty Decontamination System Skin Decontamination Kit (PCDS SDK)", the Rohm and Haas Company and its subcontractor, PACO Pharmaceutical Services Inc. focused upon improving the operational deficiencies inherent to the Prototype design skin decontamination system developed under a previous contract (#DAMD17-85-C-5200). Phase I of this contract called for the upgrading of the existing design of the earlier prototype PCDS SDK; manufacture and delivery of 5,000 engineering development prototype kits to support contractor/Government testing; development of an operator's manual and development of a Technical Data Package (TDP).

In order to support the new designs, Level I drawings and specifications were prepared for the applicators, packets, soft pack pouch assemblies and also the unit of issue (box of 20 decontaminating kits). Procurement of materials, manufacturing process development and obtaining equipment/tooling were accomplished prior to kit manufacture.

The FDA has determined the Personnel/Casualty Decontamination System - Skin Decontamination Kit (PCDS-SDK), ultimately type classified as the Decontaminating Kit, Skin: M291, to be a medical device and subject to FDA regulation as such. Thus, the M291 (SDK) would ultimately be produced under current Good Manufacturing Practices (cGMP's) as controlled by 21 CFR 820.

Studies to establish an actual shelf-life for the Ambergard[®] IE-555 resin component of the SDK were initiated during the ninth month of the contract. Sample packets were stored at 0°C, room temperature, 40°C, and 60°C. The packets stored in the 60°C environment developed leaks as a result of packet heat seal failure. Records indicated the 60°C oven had experienced a number of unexpected temperature excursions well above the 60°C setting. However, all Ambergard IE-555 resin stored up to 3 years in packets that maintained their heat seal integrity met all product specifications. Also, all Ambergard IE-555 resin stored for 3 years, including the 60°C samples, showed no decrease in sorptive capacity and all registered greater than 95% removal of thickened methyl salicylate during simulated decontaminations.

At the conclusion of Phase I the Government chose to exercise Option I of this contract and enter into Phase II. The stated objectives of this Option I, Phase II were to manufacture initial production quantities of what has now been named the Decontaminating Kit, Skin: M291, and to demonstrate: 1) pre-production scale-up/manufacturing capabilities, 2) quality control acceptance, 3) procedures to provide kits for First Article Tests (FAT), and 4) Technical Data Package (TDP) validation.

Included in this second phase were work segments designed to address the technical challenges and management controls associated with the initial production of the M291 SDK at manufacturing rates representative of commercially designed equipment. The efforts included: the establishment of a Configurational Management Plan (CMP), the preparation of the First Article Inspection Procedure (FAIP) and Report (FAIR), the preparation of the Quality Assurance Program Plan (QAPP), and the completion of the Lot Technical Data Records. In addition, the program was designed with sufficient flexibility to explore kit design upgrades and to prepare Engineering Change Proposals (ECP's) to introduce modifications to the TDP.

In a general sense, these categories define the continuation of some Phase I activities into Phase II, along with equipment and facilities preparation and a formal generation of plans to maintain costs, property, specifications, manufacturing steps and product assurance.

A. SYSTEM DEVELOPMENT

1. Kit Design

Several design deficiencies in an earlier prototype were identified as a result of user testing and Rohm and Haas' developmental testing under the previous contract, DAMD17-85-C-5200. These prototypes failed to meet the requirements of AR 70-71. Because of the flaps, handles and peelable heatseals incorporated into the design, the two prime criteria of AR 70-71, chemical hardness and decontaminability, were not achievable. Another major design issue was free powder loss during resin delivery and the potential for excessive dusting during facial application.

A change in design was proposed to meet these deficiencies. The newer design retained the non-woven applicator, but packaged the applicator in a protective foil envelope. No flaps, handles, or heat-sealable surfaces were exposed. Furthermore, the Ambergard[®] XE-555 resin was filled between the non-woven pad and an occlusive, heat-sealable film material to which a non-woven strap/handle was attached. Loading the resin behind the non-woven eliminated the dusting problem. The thickness and rate of resin release through the pad was controlled by the density of the non-woven. The pad was then folded and oriented in the pouch such that it formed a saddle in the bottom of the pouch, retaining resin inside it.

a. Foil Laminate Selection

A major concern with the earlier prototype kit design was the identification of a 'peelable' heatseal coating that could meet the chemical hardness requirements of AR 70-71. To help in the selection of the appropriate material, several simulant 'quick tests' were performed on a variety of foil laminate candidates:

- A. Reynolds #22781A - (foil used for earlier prototype).
 - 1. 0.48 mil polyester film
 - 2. 1 mil aluminum foil
 - 3. primer
 - 4. vinyl heatseal coating

- B. Reynolds Retort
 - 1. 0.48 mil polyester film
 - 2. adhesive
 - 3. 0.7 mil foil
 - 4. 3.0 mil polyethylene terephthalate (PET)

- C. Tolas TPC-0760
1. 0.48 mil polyester film
 2. 0.50 mil low density polyethylene (LDPE)
 3. 0.35 mil aluminum foil
 4. 0.70 mil Surlyn[®] 1652 (Dupont ionomer resin)
 5. 0.20 mil heatseal HS3-48A
- D. Tolas TS-2090
1. 0.48 mil metalized PET
 2. 2.00 mil black rubber modified high density polyethylene (HDPE)
 3. Peelable heatseal
- E. RJR Archer #1
1. 0.48 PET
 2. adhesive
 3. 1.0 mil foil
 4. 2.0 mil Archer coextrusion - blend of HDPE, LDPE, ethyl vinyl acetate (EVA) and sealant
- F. RJR Archer #2
1. 0.48 mil PET
 2. adhesive
 3. 1.5 mil foil
 4. 5# heatseal coating (polypropylene dispersion)
- G. RJR Archer PD-5433
- This was a relatively new (as of 1987) Archer foil similar to Archer #2. It has a polypropylene dispersion heatseal as does #2, but less of it over an epoxy coating. There is no outer coating on PD-5433. The heatseal on the PD-5433 can be colored clive drab, while #2 cannot.
- H. Aclar[®] 33C
1. 2.0 mil chlorotrifluoroethylene (CTFE) fluorocarbon
- I. Saranex[®] 23P (2.0 mil)
1. LDPE
 2. saran (polyvinylidene chloride)
 3. EVA copolymer
- J. Aluminum foil (control sample)

The 'quick tests' consisted of placing a piece of the candidate foil laminate over a 2 ounce jar containing 1.0 mL of methyl salicylate. Methyl salicylate was selected as the simulant because its physical properties are similar to dD and because it is easily analyzed at very low concentrations by UV spectroscopy. The foil was covered with a glass plate and allowed to stand at ambient temperature for 24 hours. At the end of the exposure period the foil was extracted with methanol and analyzed by UV for methyl salicylate. No attempt was made to insure that the laminates had reached equilibrium. The results were used as a means of relative comparison. The data are summarized in Table 1. This method allowed evaluation of each side of the candidate laminates separately.

Table 1
Candidate Foil Laminate Chemical Hardness Evaluation

| Supplier | Sample | Surface | DS-2 Appearance (a) | MS Appearance (b) | MS Vapor Sorbed mg/cm ² (c) (d) | |
|------------------|----------------|----------------|---------------------------|-------------------------|--|----------------|
| Reynolds | 22781A | outer inner | no change turn black | no change dissolved | 0.002 0.19 | NR NR |
| Reynolds | Retort | outer inner | no change no change | no change dissolved | 0.002 0.048 | NR NR |
| Tolas | TPC 0760 | outer inner | no change no change | no change no change | 0.012 0.20 | NR NR |
| Tolas | TS-2090 | outer inner | sl shiny sl darker | no change darker | NR NR | NR NR |
| RJR Archer | #1 | outer inner | no change no change | no change no change | 0.002 0.097 | NR NR |
| RJR Archer | #2 | outer inner | no change no change | no change no change | 0.001 0.027 | 0.007 0.040 |
| RJR Archer | PD-5433 | outer inner | Not Run NR | NR NR | 0.0 0.030 | 0.002 0.080 |
| Allied | Aclar 33C | - | no change | no change | NR | NR NR |
| Dow | Saranex 23P | outer inner | no change turn amber | no change no change | 0.18 0.24 | NR NR |
| Aluminum foil | Control | outer inner | NR NR | NR NR | 0.0 0.0 | NR NR |

- (a) Physical appearance after 30 minutes exposure to a single drop (0.25 mL) of DS-2 decontaminant at 24 C.
 (b) Physical appearance after 30 minutes exposure to a single drop (0.25 mL) of liquid methyl salicylate (MS) at 24 C.
 (c) 24 hours exposure to methyl salicylate vapor at 24 C.
 (d) 72 hours exposure to methyl salicylate vapor at 24 C.

NOTE: NR = Not Run

It was readily apparent that the polyester (PET) outer layer, present on most samples, provided much better protection than the heatseal inner layers. As RJR Archer's PD-5433 appeared to be the best candidate, we would have recommended using this coating for the heatseal with a PET/adhesive outer coating. However, due to a change in the overall design, a peelable heatseal was no longer required and the inner coating would not be exposed, thus the requirement for inner surface chemical resistance was eliminated. The new design retained the non-woven applicator, but packaged the applicator in a protective foil envelope. After much testing was performed on numerous candidate structures, the following laminate supplied by the RJR Archer Company was selected:

48 gauge Polyethylene terephthalate (exterior)
 Ink
 Pigment
 Adhesive
 1 mil aluminum foil
 Adhesive
 1 mil coextrusion (EVA/PE, EVA, Surllyn, EVA)

The polyethylene terephthalate (PET) was selected for its chemical agent resistance while the text was reverse printed gold on an olive drab background for "low light" visibility. A 1 mil foil was selected to prevent pinholing in the structure. The coextrusion helped prevent seal failures/leakage because of its strong sealing characteristics.

b. Applicator Pad Development

The primary objective in choosing the proper applicator pad material was to retain the decontaminating resin prior to use while providing the ability to dispense the resin freely. It also was important to maintain narrow yet strong bonds between the nonwoven material and the applicator pad backing. Several non-woven materials were received for evaluation from Kemwove, Inc., Charlotte, North Carolina. Three sample applicator pads were made from each sample and loaded with 2.8 grams of Ambergard XE-555 decontaminating resin. The pads were then rubbed over a 1300 sq. cm. Kydex[®] sheet surface in a consistent and reproducible manner. The resin weight loss from each pad was determined and the average loss for each non-woven is reported in Table 2. As is evident from the data, an entire range of resin delivery rates can be achieved by varying the type of non-woven. The SCN 87-28 yielded the fastest delivery rates, but this material was too porous since resin was observed to fall out while the pad was being filled. Kemwove SCN 87-29 (composed of 100% polyester fibers, 6 and 15 denier, 50% each, bonded with acrylic) was determined to best meet requirements.

Table 2
Evaluation of Candidate Non-woven Materials

| Material | Binder Type | Average Resin Weight Loss |
|-----------|-------------|---------------------------|
| CBC 1.85 | Acrylic | 1.20 g |
| CBC 3.0 | Acrylic | 1.00 g |
| SCM 86-4 | PVC | 0.66 g |
| SCM 86-8 | PVC | 0.72 g |
| SCM 87-28 | Acrylic | 2.53 g |
| SCM 87-29 | Acrylic | 1.37 g |

c. Polyester Film Backing

The revised design created the need for a heatseal coating on both sides of a polyester film laminate so the nonwoven handle would seal to the pigmented surface and the nonwoven pad would seal to the inside surface. RJR Archer laminate (PD-5453) met these needs and has the following composition:

1 mil LDPE (olive drab)
adhesive
48 gauge polyester
adhesive
1.5 mil EVA

3M's Scotchpak 146 would also satisfy our needs but 3M Company could not pigment the material in a timely fashion. Therefore, the material was ordered from 3M, and another Company, Patton, was contracted to coat the Scotchpak with an olive drab (OD) pigment. In order to keep both options open and avoid delaying the program, polyester backing material was purchased from both Archer and 3M/Patton.

d. Pouch

Difficulties were encountered trying to maintain satisfactory pouch heat seals. Improved adhesive coatings for the pouch material, Tyvek[®], were analyzed and Tyvek 1073D with ITD 1367 adhesive (Tolas Health Care Company) was chosen.

Size changes were necessary to accommodate the design revision to the packet assembly. The selected printing colors were the olive drab 574C (2 sides) and gold 872C (1 side text only).

B. KIT MANUFACTURE

1. Production of Initial 5,000 Prototype Kits

The production of the initial 5,000 skin decontaminating kits (SDK's) required for Phase I was divided into a series of steps: handle production, applicator pad assembly, pad/handle assembly, packet production, resin filling, packet loading, packet sealing, lot coding, notching, and pouch assembly. For the most part, production was accomplished utilizing manual labor and operating machines designed specifically for this Phase of the contract. Approximately 200 pounds of Ambergard XE-555 decontaminating resin produced under Contract DAMD17-85-C-5200 was consumed during the production of the 5,000 kits.

a. Handle Production

The handles were produced using a steel rule die on a pneumatic press (Atlas Vac.), cutting to a 4 1/2" length from a roll of Kenwove SC87-29 nonwoven materials. Excess nonwoven material needed to be trimmed during handle/pad assembly resulting in handle waste greater than 50 percent.

b. Applicator Pad Assembly

To assemble the Kenwove nonwoven facing material with the polyester backing material, a Klockner Form/Fill/Seal machine (Model CP5, Serials 1775/21) was used. The machine was modified extensively to accept and process large diameter rolls of nonwoven facing material. A special "T" shaped sealing die and a steel rule cutoff die were designed and fabricated to seal and cutoff assembled pads. The machine settings were:

- a. Temperature: 295°F;
- b. Line pressure: 95 psi;
- c. Dwell time: 3.1 seconds;
- d. Output: 19 units per minute.

Losses of both the nonwoven facing and polyester backing materials in this phase of the manufacturing process exceeded 20 percent.

Scrap losses in the manufacture of fiber pads assembled with the polyester backing materials were greater than originally projected. As a result, two additional orders for nonwoven pad material were required.

c. Pad/Handle Assembly

The pad/handle assembly utilized a highly modified Air Mite pneumatic presses and special tooling. The tooling incorporated a mandrel around which the nonwoven handle was heat sealed to the fiber pad forming an arch for simplified finger insertion. Machine settings were:

- a. Temperature: 330°F;
- b. Pressure: 60 psi;
- c. Dwell time: 4.5 seconds.

The nonwoven material used for the handle was difficult to attach to the polyester backing material. Also, the slitting of the nonwoven to the proper width was not easily controlled. It was evident that revisions would have to be considered prior to advancing to full scale production.

d. Packet Production

There were two areas of concern regarding the packet material. First, the initial shipment of material consisted of a high percentage of impressions with smeared gold ink. The units which were of questionable quality were rejected, while only those which were legible and met fit, form, and function, were utilized for kit manufacture.

Efforts were made to ensure the integrity of the packet heatseals by pressure testing the sealed packets after adjusting the temperature, pressure, and dwell time of the heatsealer.

e. Resin Filling

The filling of resin was accomplished through the use of Kinnematics volumetric fillers equipped with a vacuum pump. All filling was done under a hood to control airborne resin. Weighing of the resin-filled applicator pads was performed on a Sartorius balance with digital readout to 0.01 gram. The acceptable net weight resin fill limit was 2.8 g \pm 5% (2.94 - 2.66 grams). Due to the variability in the applicator pad tare weight, each operator was instructed to manually add an additional amount of resin to the pad when the scale indicated a low weight. After weight confirmation, the top seal was formed on the open edge by a pneumatic heat seal press. A photograph (Figure 1) of an opened applicator pad prototype filled with Ambergard XE-555 resin is attached.

f. Packet Loading

The manual loading of applicator pads into the packets was done with and without a "knife" to aid in the opening of the stiff foil packets. The knife was replaced by a scoop-like tool to widen the cavity of the foil packet. The scoop-like tool was next permanently mounted to the work surface, simplifying the work of inserting the applicator pad into the absolute bottom of the packet.

g. Packet Sealing/Lot Coding

The fourth edge of the packet was sealed using a custom designed pneumatic heat seal press. The same machine was equipped with two sets of dies whereby the manufacturing lot number could be debossed into the bottom seal of the packet simultaneous to the sealing of the top, fourth edge of the packet.

h. Notching

The notching of packets was performed initially by a manually operated device. It was later upgraded to a semi-automatic machine. Incorporated in the machine was a go/no-go gauge to certify that the packets conformed to the thickness specification.

The current dimensions specified for the heat seals were 0.25 ± 0.06 inch and for the notch depth, $0.06 \text{ plus } 0.06/\text{minus } 0.00$ inch. The depth of the tear notch at the maximum dimension and the heat seal at the minimum dimension leaves only a 0.06 inch seal area remaining. This situation could conceivably contribute to packet leakage. Thus, the packet dimension specifications would require further evaluation. A photograph (Figure 2) of the finished, loaded, prototype SDK packet is attached.

DECONTAMINATING KIT, SKIN: XM291

[Prototype]

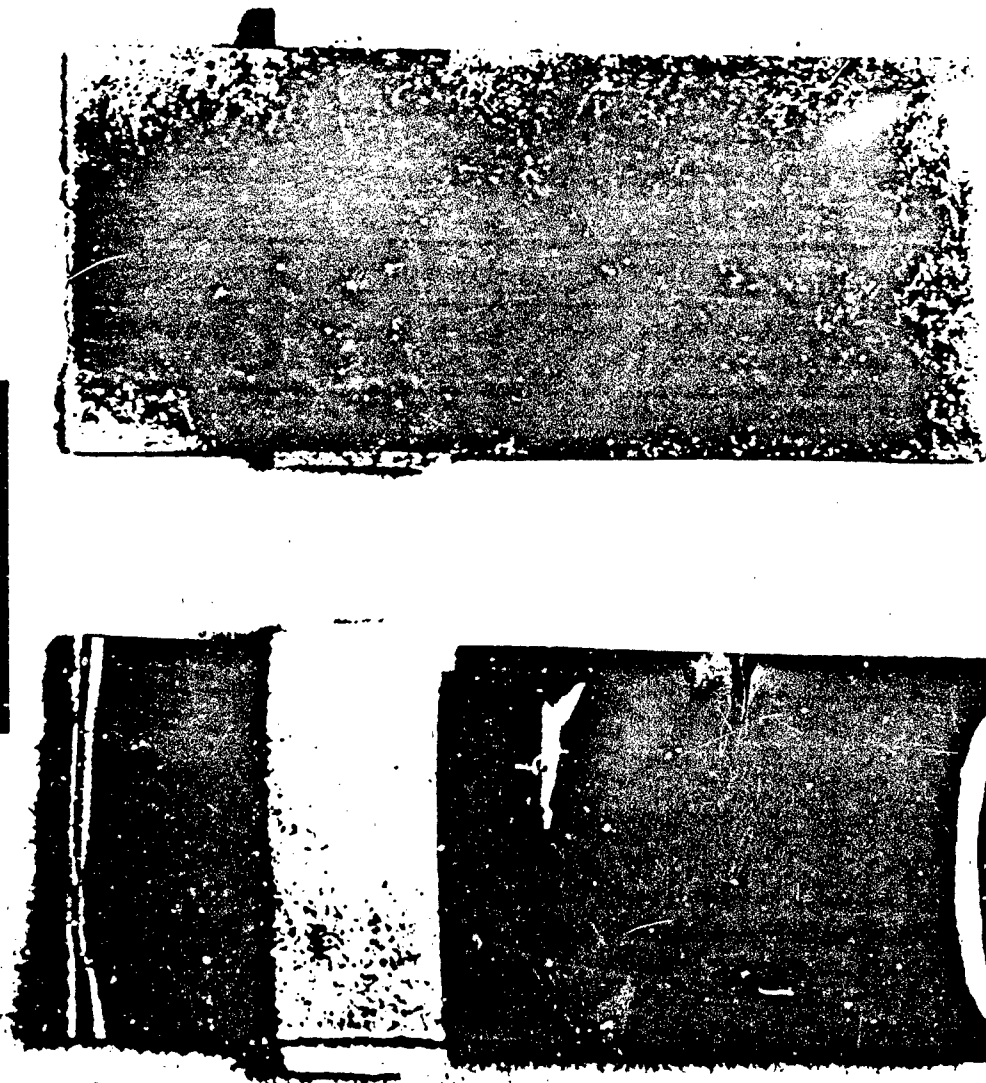

APPLICATOR

FIGURE 1

DECONTAMINATING KIT, SKIN: XM291

(Prototype)

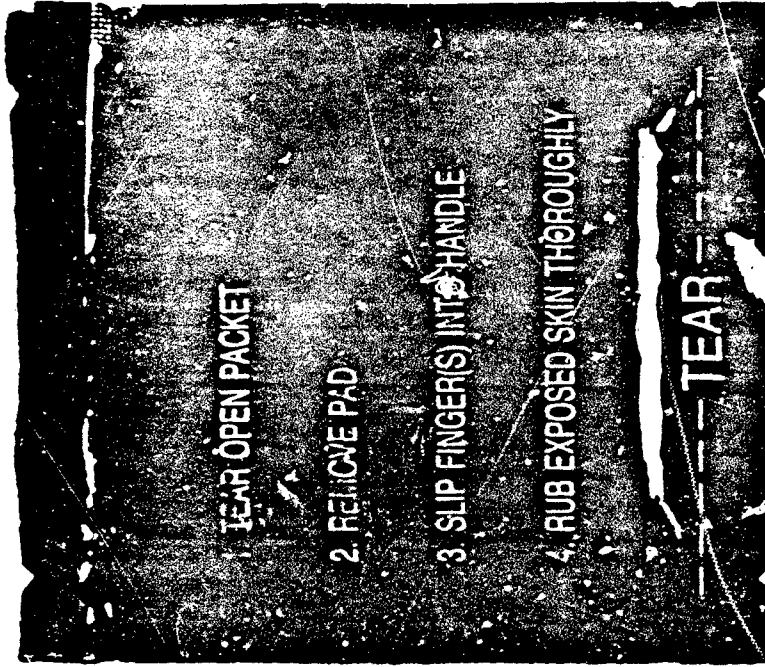

SKIN DECON PACKET

Figure 2

1. Pouch Assembly

One of the last machines designed and built for this initial 5,000 kit production run was the pouch sealer. The unit which incorporated several safety features consisted basically of a pneumatic heat seal press. The unit was used to pre-assemble the pouch. The packets were manually loaded into the pouch during a subsequent assembly step.

2. Kit Manufacture Summary

a. Equipment/Tooling Suppliers

The following is a list of the equipment utilized for the manufacture of the initial 5,000 kits required in Phase I:

| <u>Machine</u> | <u>Supplier</u> | <u>Function</u> |
|--------------------------------------|-----------------|---|
| Form, fill & seal (Model CP5) | PACO/Klockner | Seal nonwoven to polyester backing material (3 sides) |
| Pneumatic press/handle tooling | Air Mite/PACO | Seal handle to rear of polyester handle |
| Volumetric filler with vacuum pump | Kinnematics | Filler of Ambergard pad |
| Pneumatic press/seal tooling | PACO/Air Mite | Seals top of applicator pad |
| Form, fill and seal | PACO/Klockner | Forms 3 sided seal on packet |
| Applicator pad fill and exhaust hood | Torit | Provides dust collection & resin control |
| Packet seal/deboss | PACO R&D | Seals top of packet and debosses code numbers |
| Pneumatic press/tear notch | PACO/Air Mite | Place notches in packet |
| Digital balance | Sartorius | Accurate weighing to determine volume fill of Ambergard resin |
| Pneumatic press/Tyvek tooling | PACO | Forms seals on Tyvek pouch |

All of the deliverable kits were distributed to the various testing agencies as per contract requirements. At this stage the kits were officially designated as the "Decontaminating Kit, Skin: XM291" or, more informally, the XM291. A photograph (Figure 3) of the fully assembled prototype kit (XM291) is attached. The kits were packed in boxes (the "Unit of Issue" containing 20 kits per box), overwrapped and then placed in master shippers (4 squad containers per shipper). The overwrap material selected was from Spec-Fab (Jaite Boilable Pouch) and consisted of 1 mil polyester and 2 mil MDPE. The following box constructions were used for the 5,000 kits produced during this phase:

Intermediate Container (Unit of Issue)

- Level B Packaging
- Fiberboard grade, class domestic IAW PPP-B-636J
- Style Regular Slotted (RSC) IAW PPP-B-636J
- Flaps taped with non-asphaltic reinforced tape IAW PPP-T-45

Shipping Containers (Master Shipper)

- Level B Packaging IAW MIL-P-14232E
- Fiberboard grade W5c, WWVR PP2-B-636J
- Style Regular Slotted (RSC) IAW PPP-B-636J
- All openings/seams taped with duct tape IAW PPP-T-60

The XM291 Lot Distribution Report is summarized in Table 3.

DECONTAMINATING KIT, SKIN: XM291

(Prototype)

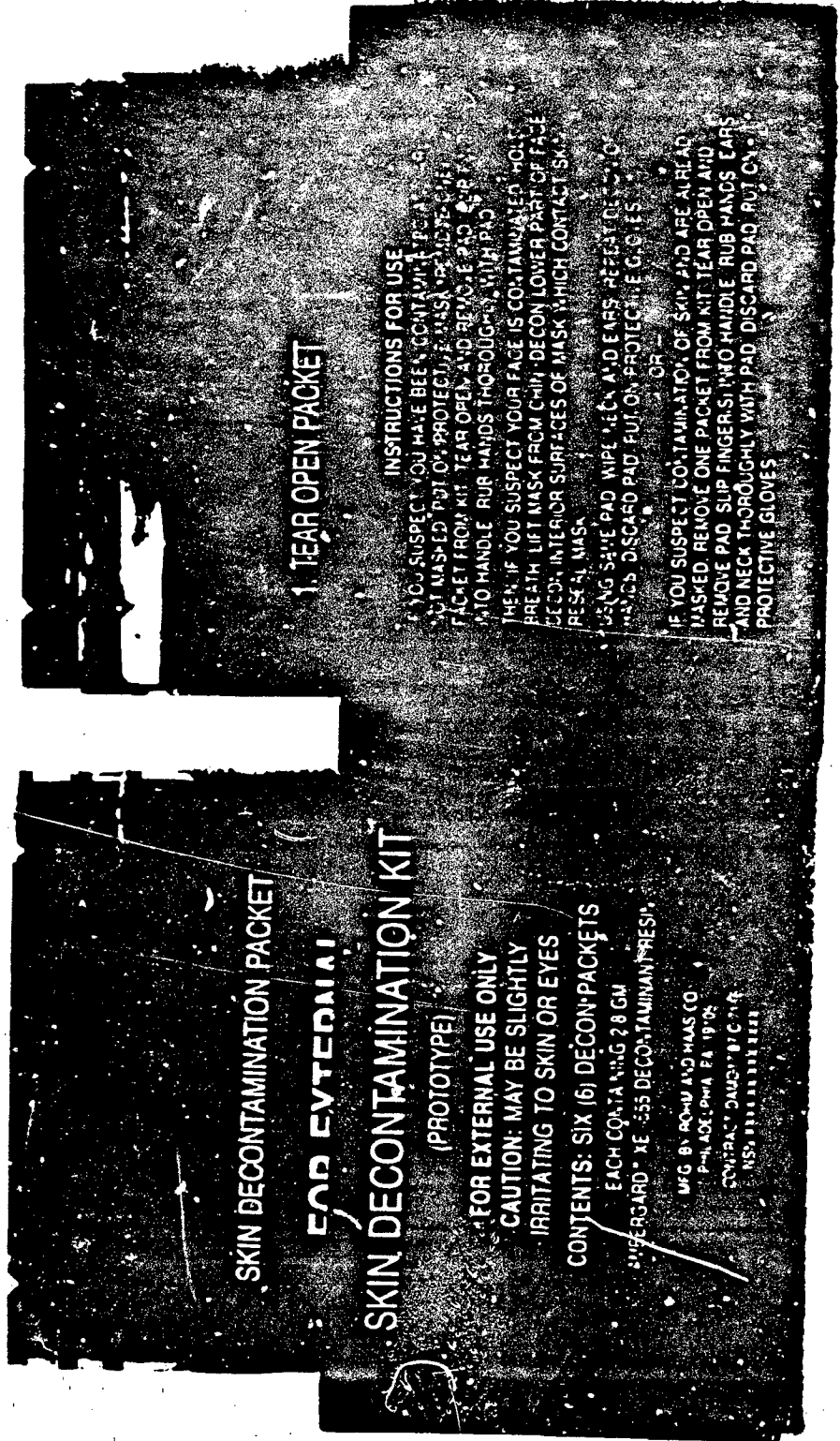

Figure 3

Table 3
Lot Distribution Summary

| DESTINATION | LOT NUMBER | NUMBER OF KITS |
|--|--|--|
| Battelle Columbus, Ohio | 17NOV87A | 200 |
| U.S. Army A&E Board Fort Knox, Kentucky | 18NOV87A | 120 |
| U.S. Army Chemical School Fort McClellan, AL | 17NOV87A | 20 |
| U.S. Army Biomedical Research and Development Lab Frederick, MD | 9NOV87A 7NOV87 12NOV87A 18NOV87AR 10NOV87A 5NOV87 | 160 80 160 160 80 160 |
| U.S. Army Tropic Test Center Corozal, Panama | 16NOV87A 13NOV87A 12NOV87A 4NOV87 3NOV87 | 240 240 40 40 40 |
| Meadows Van and Storage, Inc. Frederick, MD | 30OCT87 11NOV87A 10NOV87A 12NOV87A 13NOV87A 2NOV87 6NOV87 7NOV87 14NOV87A 17NOV87A 4NOV87 9NOV87 9NOV87A 19NOV87AR 5NOV87 3NOV87 18NOV87A 18NOV87AR 16NOV87A | 80 160 100 60 80 80 140 40 160 140 60 60 20 260 40 60 40 40 40 60 |

| DESTINATION | LOT NUMBER | NUMBER OF KITS |
|---|------------|----------------|
| Rohm and Haas Company Spring House, PA | 11NOV87A | 100 |
| | 14NOV87A | 100 |
| | 3NOV87 | 160 |
| | 6NOV87 | 40 |
| | 6NOV872 | 100 |
| | 27OCT87 | 100 |
| | 2NOV87 | 160 |
| | 4NOV87 | 120 |
| | 12NOV87A | 80 |
| | 16NOV87A | 120 |
| | 30OCT87 | 160 |
| | 28OCT87 | 140 |
| | 5NOV87 | 60 |
| | 7NOV87 | 40 |
| | 18NOV87A | 20 |
| | 20NOV87AR | 400 |
| | 10NOV87A | 40 |
| | 13NOV87A | 60 |
| | 17NOV87 | 20 |
| | 18NOV87AR | 20 |
| 19NOV87AR | 40 | |
| 5OCT87 | 20 | |

C. INSPECTION, TESTING AND EVALUATION

1. Shelf-Life Studies

Actual shelf-life tests for the Ambergard XE-555 resin component of the XM291 SDK were initiated during the ninth month of the contract.

The storage conditions and sampling frequencies for the actual shelf-life tests are shown below:

| <u>STORAGE TEMPERATURE</u> | <u>SAMPLING FREQUENCY</u> |
|----------------------------|--|
| Zero Degrees C | 1, 3, 6, 9, 12, 18, 24, 36, 48, 60 months |
| Room Temperature | 0, 1, 3, 6, 9, 12, 18, 24, 36, 48, 60 months |
| 40 Degrees C | 1, 3, 6, 9, 12, 18, 24, 36, 48, 60 months |
| 60 Degrees C | 1, 3, 6, 9, 12, 18, 24, 36, 48, 60 months |

All of the storage tests were conducted on Ambergard XE-555 resin in the actual SDK packets. Below is a list of the 'in vitro' tests used to analyze the Ambergard XE-555 resin shelf-life storage samples. A detailed description of the test procedures may be found in a memo dated October 11, 1989 from John E. Schuler to LTC Donald G. Harrington.

1. Percent solids determination
2. Surface area determination
3. Particle size determination
4. Nonvolatiles, water soluble extractables determination
5. Vapor desorption evaluation (CIS and DPP)
6. Liquid sorption evaluation (Enslinn)
7. Kinetic iodine evaluation (sorptive quality)
8. Basicity determination
9. Acidity determination

Figures 4 through 13 present a graphic representation of the data obtained to date, over a 36 month period. Appendix A contains a statistical analysis of the raw data.

During the course of this study the oven initially used for the 60°C samples experienced a number of unexpected temperature excursions. As a result, the samples were transferred to a newer oven which was believed to be more reliable. Unfortunately, this oven also experienced periodic fluctuations in temperature. At one point the temperature had risen as high as 80°C. Since the ovens were checked on a weekly basis, the excursions never lasted more than 7 days. However, since the 60°C samples exhibited a

loss of heat seal integrity after 3 years (explained in more detail below), it is not known whether any changes noted in the Ambergard XE-555 resin properties were due to the long term storage at 60°C or a result of the higher temperature excursions. Also, it is not clear whether the heat seal failures occurred at 60°C or at some temperature between 60°C and 80°C. It should be noted that the packets involved in this study were not from current production, but represent the M291 prototype which was constructed during the first phase of this contract, on semi-automated machinery and the packet integrity may not be the same.

a. Percent Solids

Storage at 0°C, room temperature and 40°C have had no apparent effect on percent solids. However, storage at nominal 60°C has shown a continuous moisture loss over the 3 year period, suggesting packet leakage at this elevated temperature. Subsequent leak testing of several packets stored at 60°C for 3 years revealed packet heat seal failure as noted by a stream of bubbles issuing from the seal area of the packet after applying air pressure to the inside of the packet submerged in water. Also, visual examination of the 60°C packets revealed an obvious degradation of many packet heat seals, i.e. actual openings were observed at the packet edges. Similar evaluation of packets stored at the other temperatures showed no signs of leakage or heat seal failure.

The observed increase in percent solids for the Ambergard XE-555 resin in the nominal 60°C storage samples has been attributed to a packaging material failure. However, it should be noted that the loss of moisture has had no apparent detrimental effects on the resin's sorptive quality (Section f. below) or its ability to remove a chemical agent simulant from a Kydex plastic sheet surface (Section i. below).

b. Surface Area and Particle Size

There were no significant changes in surface area or particle size after one year storage at all four temperatures. One would not expect storage temperature to affect properties such as surface area or particle size; therefore, the decision was made to cease monitoring these 2 properties after the 1 year mark. The testing proved to be quite time consuming and it was felt that no meaningful data would result from its continuation.

c. Nonvolatile, Water Soluble Extractables

As with percent solids, the only significant change occurred at the higher temperature (60°C). Over a 3 year period the percent

extractables increased continuously from 0.024% at t_0 to 0.150% at the 3 year mark. As noted previously, the packets demonstrated a loss of heat seal integrity at nominal 60°C and therefore, the increased extractables could very well be the result of packaging material degradation.

d. Vapor Desorption (CIS and DFP)

These tests are good for evaluating the possible secondary contamination from chemically contaminated resin. The results seem to indicate that the amount of DFP or CIS desorbed actually decreased after storage at the various temperatures. This is a desirable although an unexpected result. This trend may or may not be real since there was a considerable amount of scatter in the data with greater than desired standard deviations. However, these data do at least indicate that storage at these test temperatures (0, 25, 40 and 60°C) had no detrimental effect on the sorptive properties of the resin.

e. Liquid Sorption (Enslinn)

This test yields a value related to the wettability or gross sorptive action of the resin. Although the test does not take into account any mechanical action (mixing due to rubbing), it is a good measure of the sorptive properties important for effective skin decontamination. The data suggest no apparent change in sorptive properties as a result of storage at the various test temperatures.

f. Sorptive Quality

This test measures the ability of the Ambergard XE-555 resin to remove iodine from an iodine/potassium iodide solution. During the course of this contract a number of flaws in the test procedure were discovered. At least 2 ECP's were submitted addressing this issue. Therefore, the KI (sorptive quality) data cannot be compared across time, but can be compared at any given time. At the 3 year mark sorptive quality data were obtained using the corrected procedure and the data indicate a minimum of 99.98% iodine removal for all storage temperature samples.

| <u>Storage Temperature</u> | <u>Storage Time</u> | <u>Average Iodine Removal</u> |
|----------------------------|---------------------|-------------------------------|
| 0°C | 3 years | 99.98% |
| 25°C | 3 years | 99.98% |
| 40°C | 3 years | 99.98% |
| Nominal 60°C | 3 years | 99.99% |

Thus, the increased percent solids & extractables (Sections a & c above, respectively) and the decrease in basicity (Section g, below) had no detrimental effects on the sorptive properties of the stored Ambergard XE-555 resin.

g. Basicity

Although not extreme, there was an apparent slight decrease in basicity after 3 years storage at nominal 60°C. However, if corrected for the moisture loss, the loss becomes much more pronounced, 16% decrease on an "as is" basis versus 38% decrease on a dry weight basis. Of the four components of the resin system, only the strong base resin was believed to have any significant long term stability problems. While the chloride form of the quaternary amines is very stable, the hydroxide forms are less stable at high temperatures.

One must also keep in mind the temperature excursions noted earlier. Perhaps the basicity loss would not have been as pronounced had the temperature not increased beyond the desired level of 60°C. Also, had the heat seals not failed, the resin would not have been exposed to the air and the degradation may not have occurred at all.

h. Acidity

Conversely, the acidity appears to have experienced an increase after 3 years at nominal 60°C. There was no reason to expect any change in acidity since the acidic component of the resin system is quite stable to temperature extremes. If one corrects for the loss of moisture, the increase appears much less significant on a dry weight basis, a 48% increase on an "as is" basis vs. 8% increase on a dry basis. Again, the failure of the packaging materials may have contributed to the observed changes.

i. Xydex® Sheet Surface Area Testing

In an effort to assess the efficacy of the stored samples in the removal of agent, data was generated using a rough Xydex plastic sheet surface and thickened methyl salicylate (TMS) as a simulant at a challenge level of 2.5 g/m².

Initial experiments addressed the issue of operator-to-operator variability using the room temperature stability samples. The data (See Appendix B) indicated that, within a 95% confidence limit, there was no statistical difference in the average level of decontamination achieved by operators CCC and RDL. CCC reported an average decontamination of 95.2% (±1.3) versus RDL's 95.8% (±1.3).

Next to be addressed was the issue of efficacy as a function of storage temperature. For this study the 3 years room temperature storage samples were compared to the 3 years 40°C samples with respect to the Kydex sheet surface area test. The average decontamination for the room temperature samples was 96.1% (± 0.4) and the average for the 40°C samples was determined to be 95.8% (± 1.3). Student's t-Test results (Attachment B) indicated that, within the 95% confidence limit, there was no statistical difference between samples stored at room temperature for 3 years and those stored at 40°C.

With respect to differences between the 1 year samples and the 3 years samples, there were sufficient data points only for the room temperature samples. The t-Test (Attachment B) indicated that, within the 95% confidence limit, the average level of decontamination for the 3 years samples was statistically lower than that achieved by the 1 year samples, 95.5% (± 1.3) versus 97.0% (± 0.8) respectively. This small difference is no cause for alarm at this time, but should serve as an indication that perhaps future stability testing should include the Kydex sheet surface area tests run with sufficient replicates to permit t-Test evaluation for all storage conditions.

Within any given time frame no significant differences were observed between samples stored at the various temperatures when evaluated by the Kydex sheet surface area test.

1. Storage Stability Summary

It is important to note that no direct correlation has been established between the 'in vitro' results and 'in vivo' efficacy. The 'in vitro' tests were originally designed under a previous contract to allow the ranking of candidate resin systems.

It is equally important to note that all Ambergard XE-555 resin stored up to 3 years in packets that maintained their integrity met all product specifications. Out-of-spec percent solids and basicities were encountered only after the loss of packet heat seal integrity. Also, those packets which experienced packaging material failure were not from current production and were exposed to temperatures well above the intended 60°C limit. Furthermore, considerable thought should be given to how much emphasis should be placed on the 60°C data. Is this a realistic storage temperature? Are there serious expectations of storing the M291 SDK at such an elevated temperature, 24 hours a day? High temperatures such as 60°C are generally used for FDA regulated products in order to predict long term stability. With the packaging material failures, use of the accelerated aging

scheme as a predictive tool becomes unreliable. The problem is only magnified when one takes into consideration the unexpected temperature excursions.

Consideration should be given to evaluating the thermal stability of the current M291 SDK's being produced with emphasis on improved temperature control and monitoring. With the multitude of changes that have taken place throughout this program, perhaps the packet heat seal integrity has improved sufficiently to render any concerns about storage at 60°C irrelevant.

Ambergard XE-555 Resin Stability Studies

Percent Solids Data

0° C STORAGE DATA

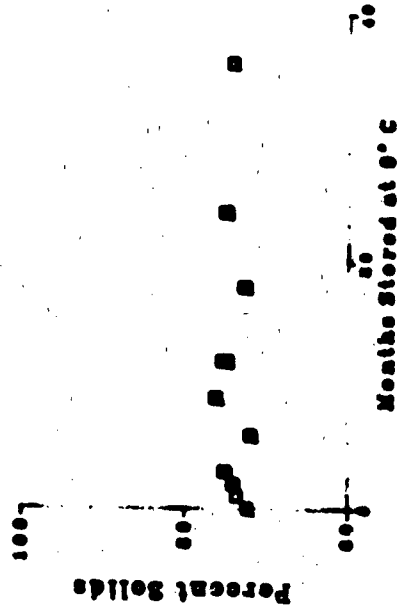

25° C STORAGE DATA

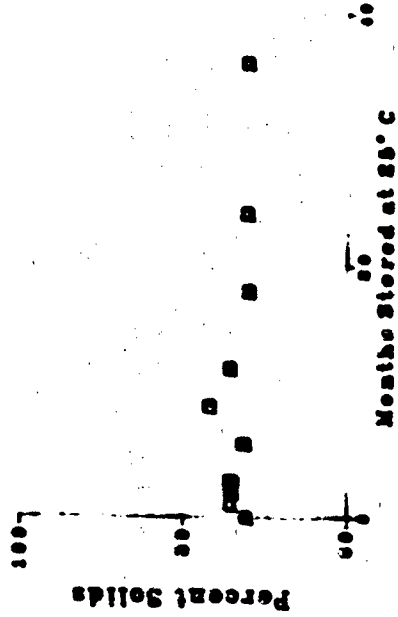

40° C STORAGE DATA

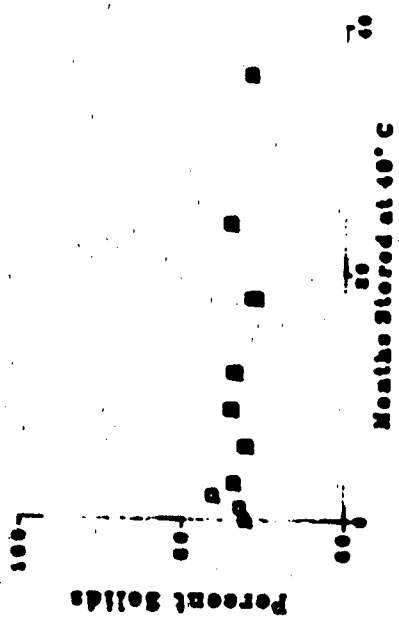

60° C STORAGE DATA

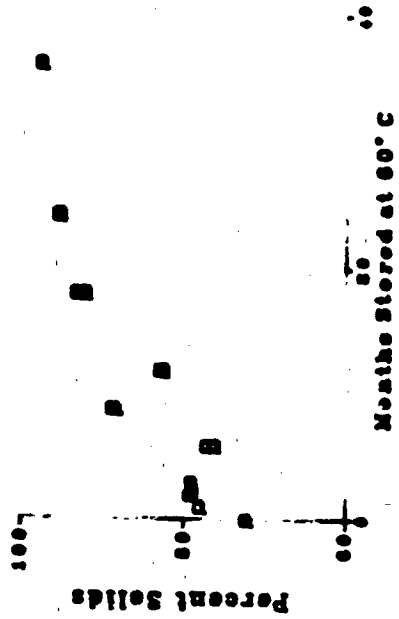

Ambergard XE-555 Resin Stability Studies

Surface Area Data (Dry Resin)

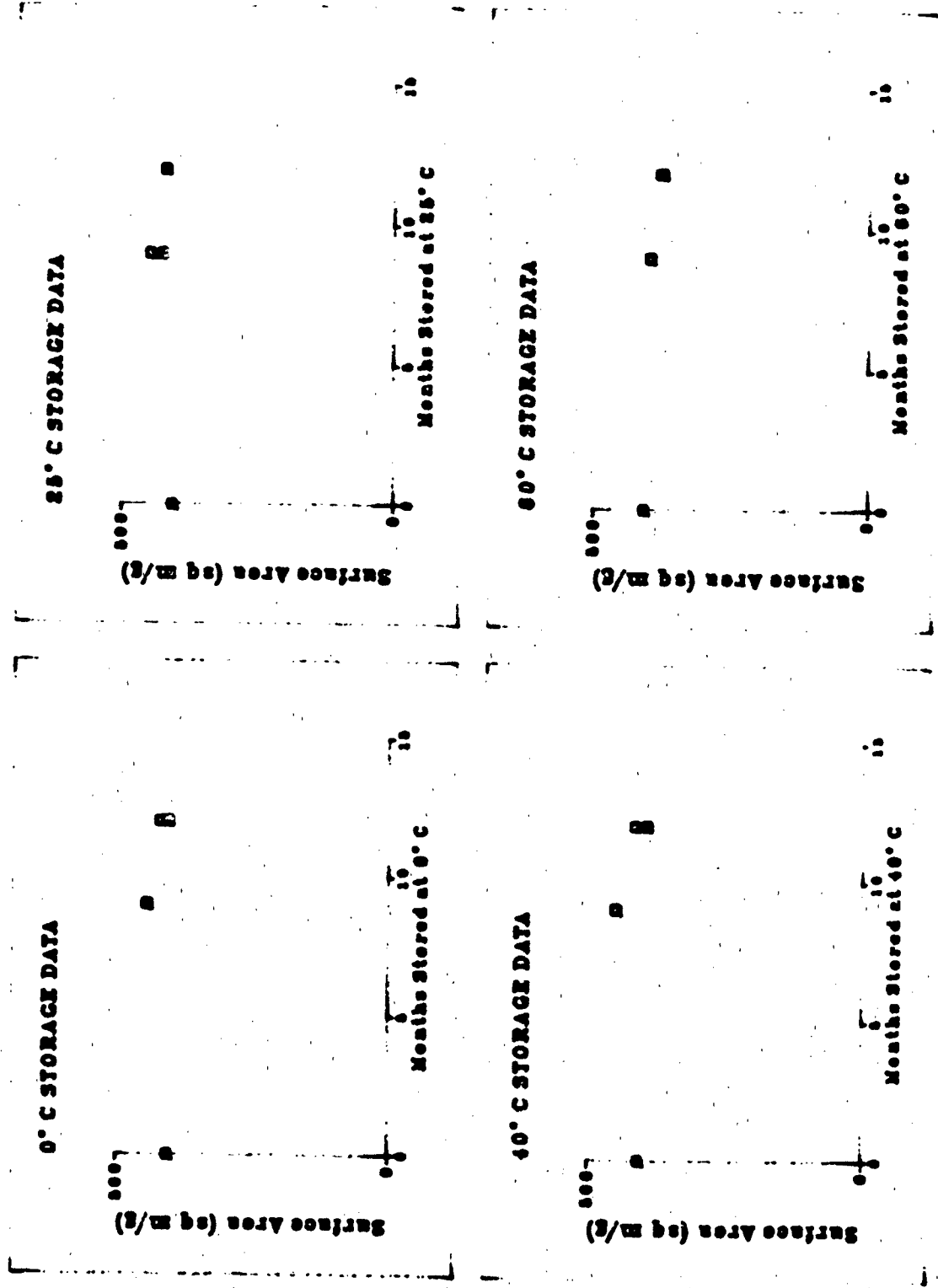

Ambergard XE-555 Resin Stability Studies

Particle Size Data

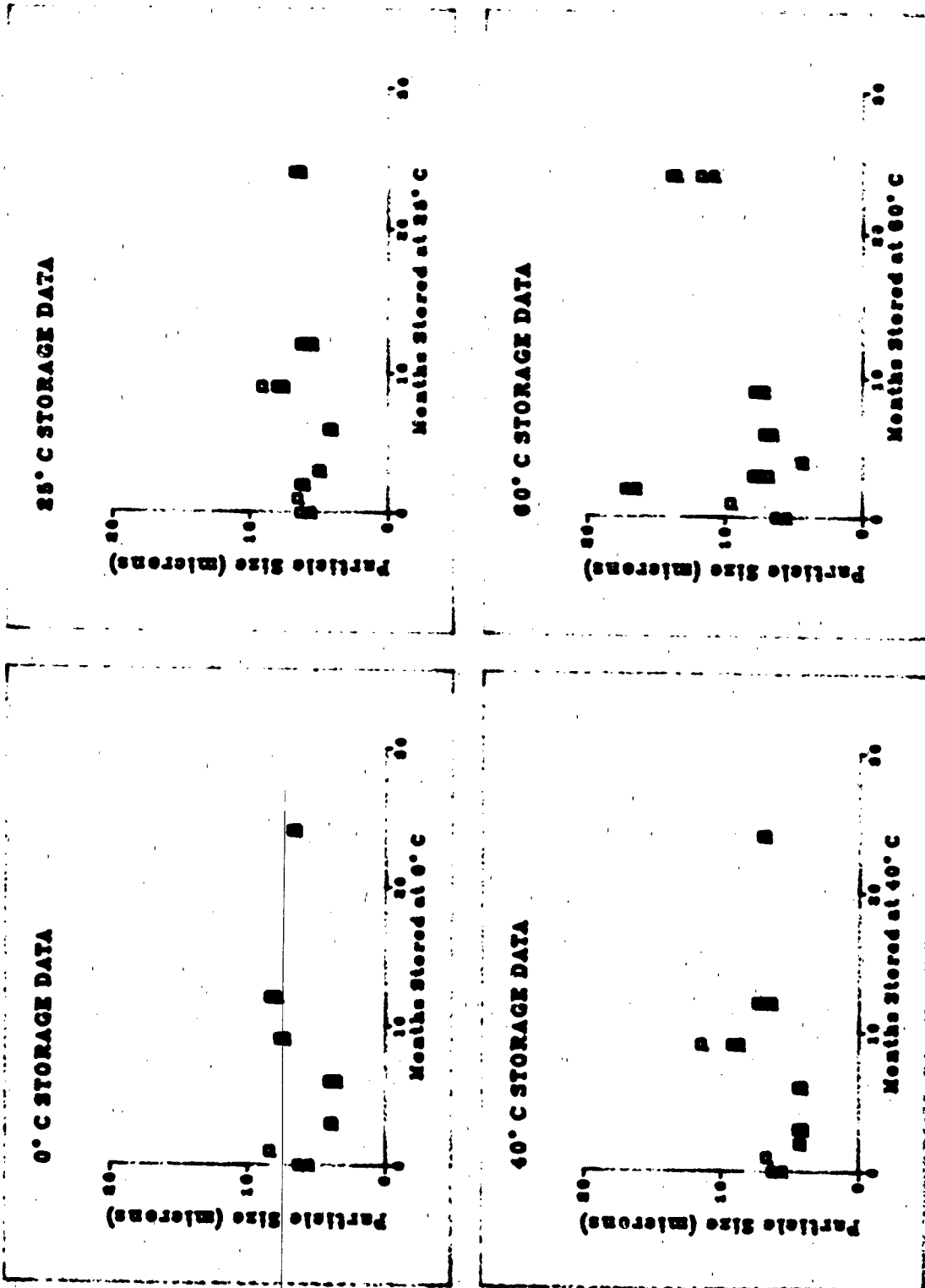

Ambergard XE-555 Resin Stability Studies

CIS Vapor Desorption Data

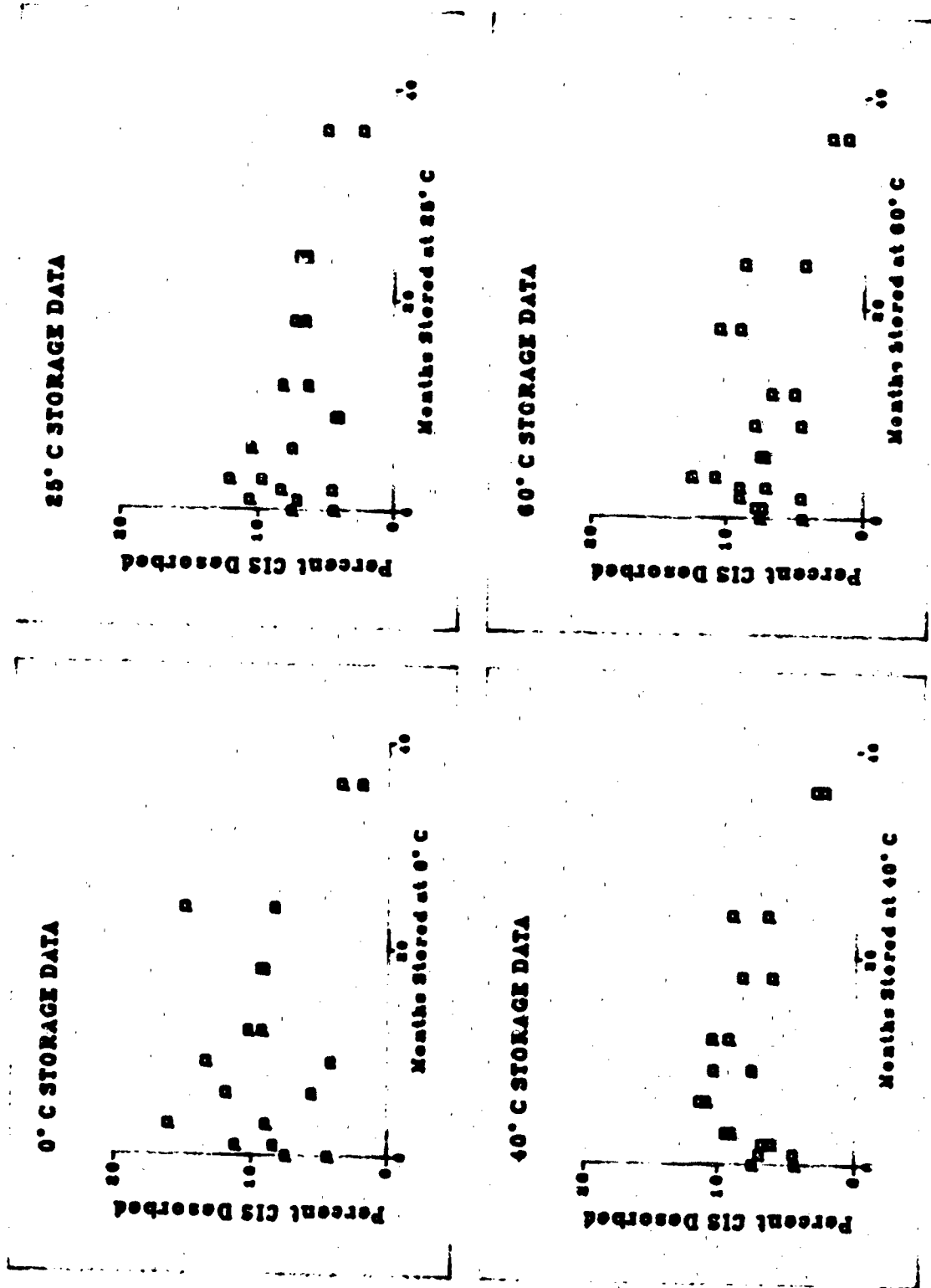

Ambergard XE-555 Resin Stability Studies

DFP Vapor Desorption Data

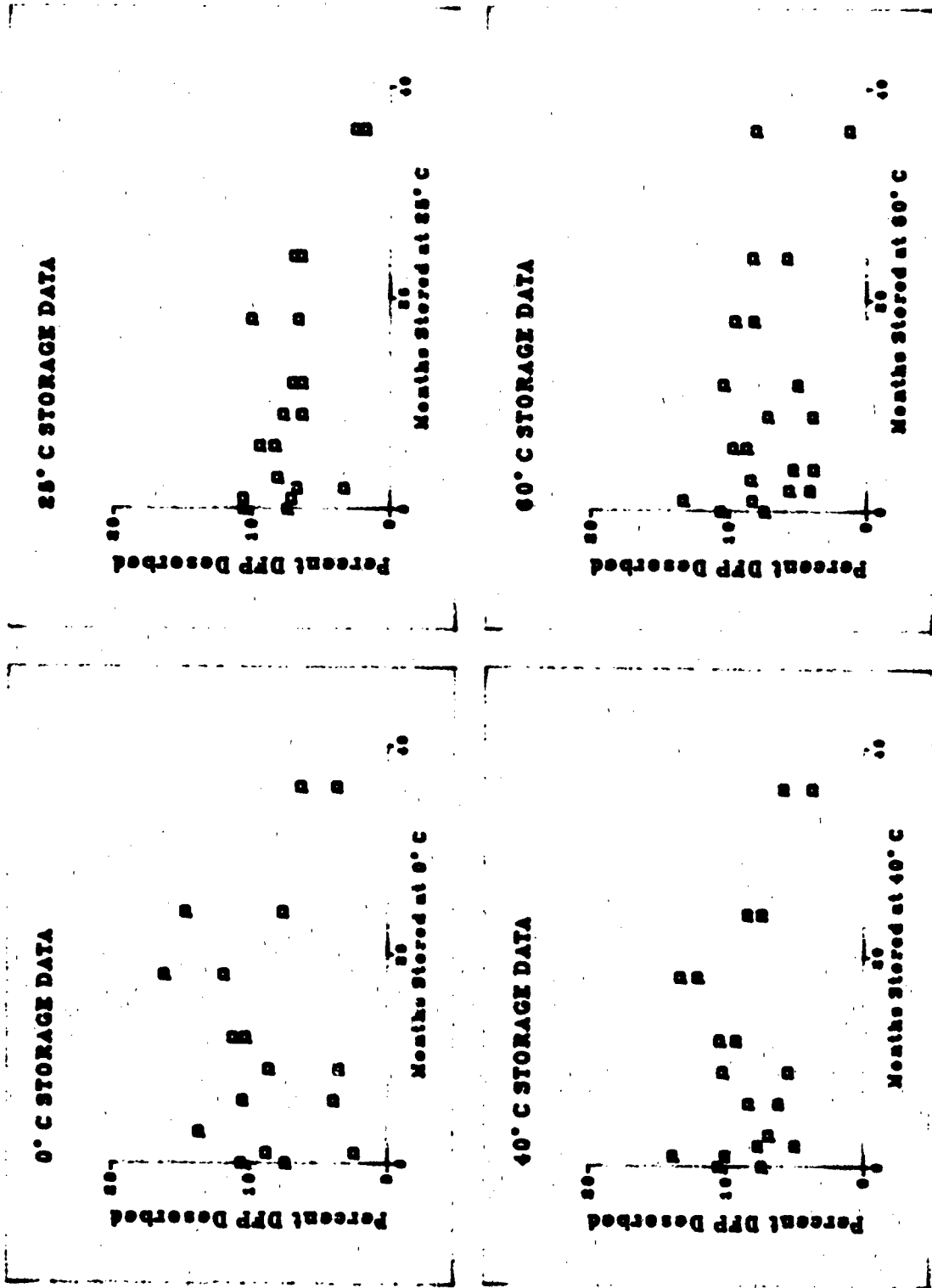

Ambergard XE-555 Resin Stability Studies

Enslinn Sorption Data



Ambergard XE-555 Resin Stability Studies

Kinetic Iodine Data

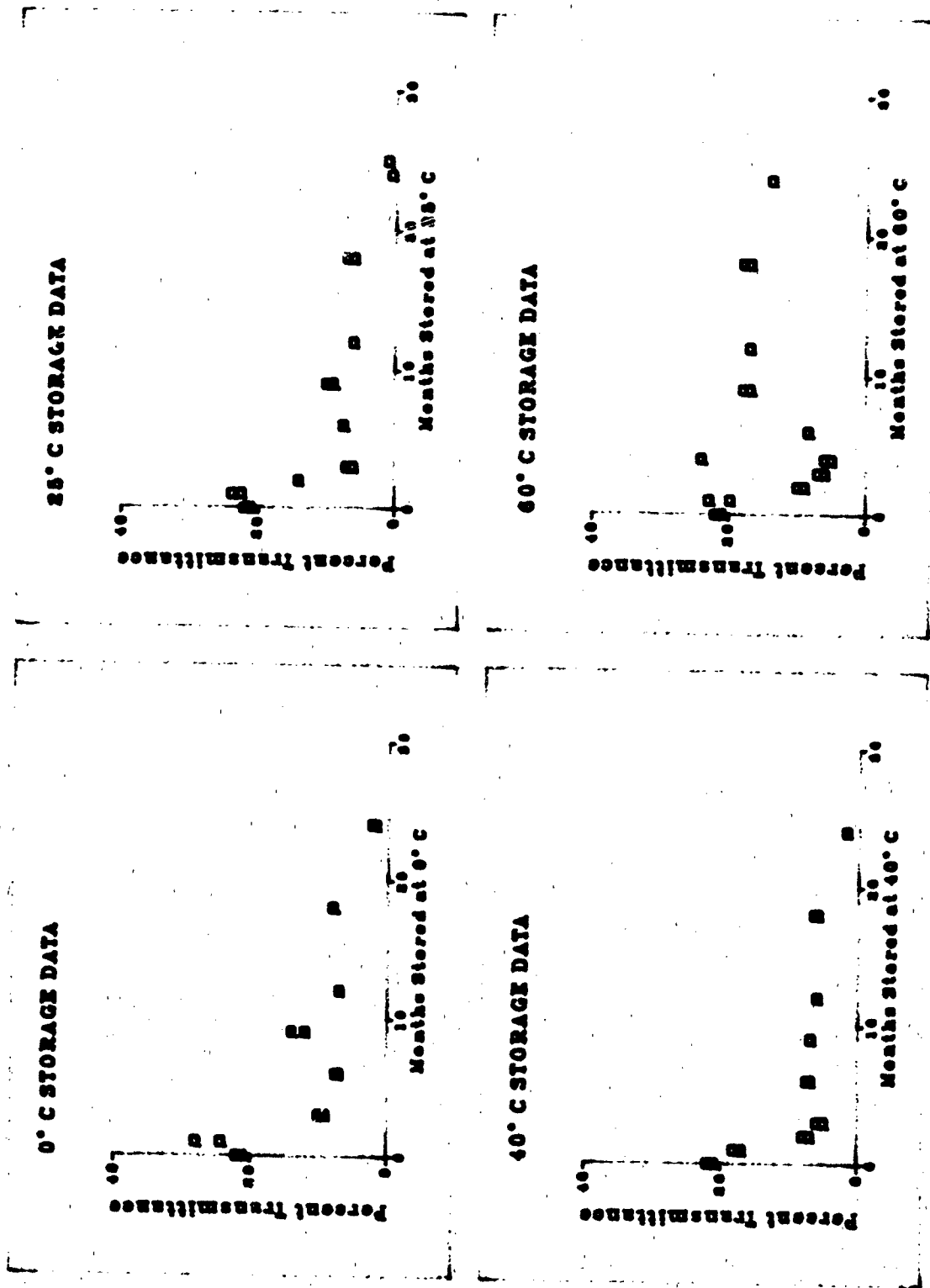

Ambergard XE-555 Resin Stability Studies

Basicity Data

0° C STORAGE DATA

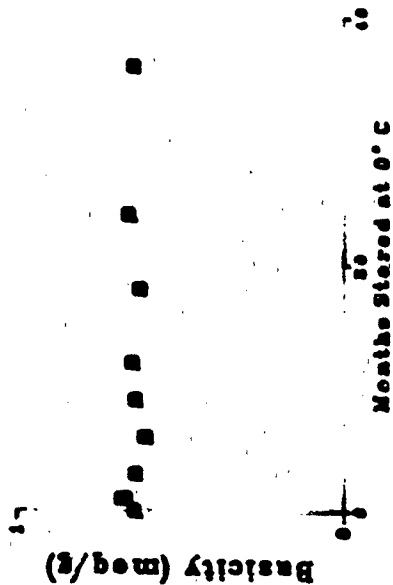

25° C STORAGE DATA

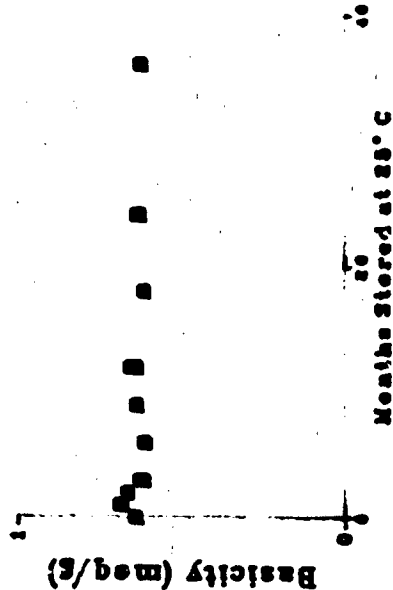

40° C STORAGE DATA

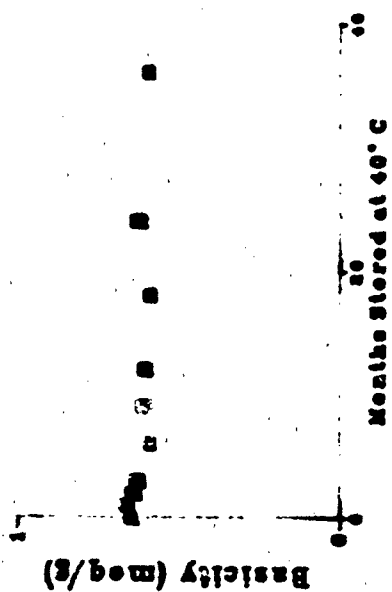

60° C STORAGE DATA



Ambergard XE-555 Resin Stability Studies

Acidity Data

0° C STORAGE DATA

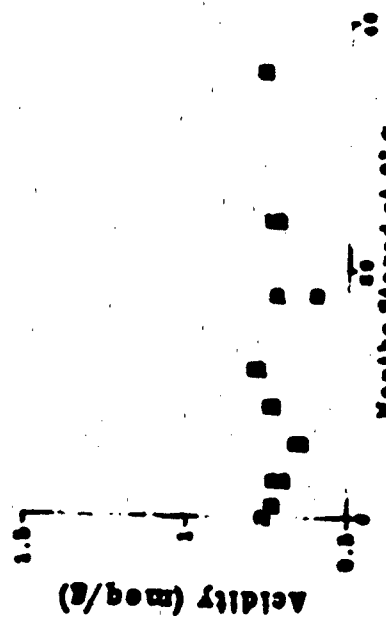

Months Stored at 0° C

88° C STORAGE DATA



Months Stored at 88° C

40° C STORAGE DATA

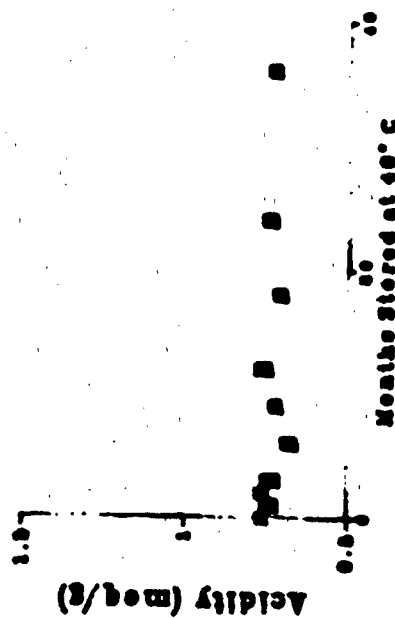

Months Stored at 40° C

60° C STORAGE DATA

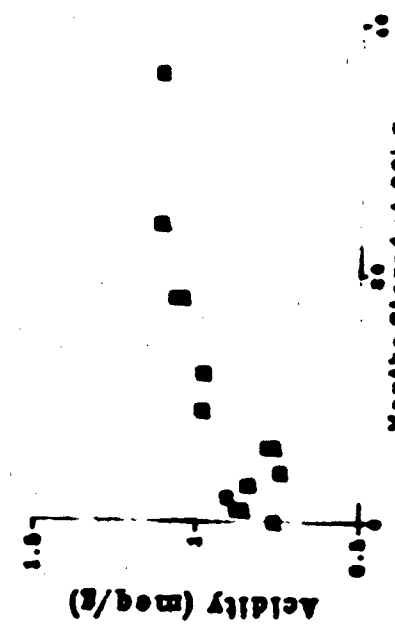

Months Stored at 60° C

2. Photoallergy Test with Natural Sunlight

a. Summary

A study was carried out at Hill Top Research, Inc., St. Petersburg, Florida to evaluate the irritation, contact sensitization and photoallergic potential of the Ambergard XE-555 resin (25% weight/volume aqueous dispersion).

Fifty eight (58) human volunteers entered the study. All applications were by 24 hour contact occlusive patches. Forty nine (49) subjects, 26 females and 23 males, completed all phases of the experimental plan. The study consisted of three phases: pretest, induction and challenge.

During the pretest phase a single application of each sample was made to a naive site on the right upper arm (utilized for photopatch evaluations) and to the left upper arm (used to evaluate irritation and contact sensitization). Patches were removed 24 hours after application by the laboratory staff and the patch area was gently wiped with a disposable cloth moistened with distilled water. Supervised sun exposure to the photopatch site was conducted within ten minutes after patch removal for a period of 15 to 20 minutes between the hours of 10:00 A.M. and 12:00 P.M. The left upper arm was shielded from sun exposure. Patch sites were evaluated 24 hours after sun exposure.

The induction phase consisted of eight applications of each sample to the photopatch site. Sun exposures were supervised on Tuesdays and Thursdays; exposures made on Saturdays were unsupervised. Photopatch sites were evaluated 24 hours after sun exposure for applications 2, 4, 5, 7 and 8 and 48 hours after exposure for applications 3, 6 and 9.

Following the induction phase, subjects did not receive application of the test materials for 9 to 11 days. During this rest time, subjects were asked to avoid sun exposure to the patch sites.

The challenge phase consisted of a single application of each sample to a naive site on both upper arms. The photopatch site was exposed to natural sunlight following the procedure outlined in the pretest phase. Evaluations were made 48 and 96 hours after application.

b. Results and Conclusions

None of the forty-nine (49) subjects completing the photoallergy test with natural sunlight exhibited responses during the pretest, induction or challenge phases.

Based on the above results, it was concluded that Ambergard IE-555 decontaminating resin shows no evidence of irritation, contact sensitization or photoallergy.

3. Repeated Insult Patch Test

a. Summary

A study was carried out at Hill Top Research, Inc., St. Petersburg, Florida, to investigate the skin sensitization potential of Ambergard IE-555 resin (25% w/v aqueous dispersion). The experimental design utilized for this study was the Jordan-King Modification of the Draize Procedure.

One hundred and sixty-eight (168) human volunteers entered the study. Induction applications of the test materials were made three times a week (on Monday, Wednesday and Friday) for three successive weeks. The Monday and Wednesday applications remained in contact with the skin for forty eight hours, while the Friday applications remained in contact with the skin for seventy two hours. One hundred and fifty-one (151) subjects, 74 females and 77 males, completed all phases of the experimental plan.

b. Results and Conclusions

None of the one hundred and fifty-one (151) subjects completing the repeated insult patch test exhibited responses during the induction or challenge phases.

No evidence of delayed contact hypersensitivity was observed during the Human Repeated Insult Patch Test.

4. Ambergard™ XE-555 Resin Compatibility with Chemical Protective Masks

a. Summary

Unmasked individuals contaminated with chemical agents will mask and then decontaminate their hands and then their face with the SDK. In the process of facial decontamination the interior surface of the protective mask will come in contact with the Ambergard XE-555 resin.

The JSOR for the SDK requires that the decontaminant must not degrade the protective characteristics of the MOPP gear. A key element in this is that the decontaminant not degrade the physical properties of the elastomers used in the construction of the protective masks. The key masks are the M17 series, the M40 and the USAF MCU-2/P. Two (2) tests, a dynamic mechanical test run at 20 degrees C and at a frequency of 10 rad/sec., and a tensile elongation test run at room temperature were used to compare the properties of mask elastomers with and without exposure to the decontaminating resin. The properties of strength and resiliency that were evaluated are the most critical to the use of the elastomers in the masks. These properties are strongly related to the molecular weight and degree of crosslinking of the elastomer. These molecular characteristics are the ones most affected by polymer degradation.

b. Details and Results

Strips of elastomer material were obtained from each of the three types of mask, the M17A2, M40, and USAF MCU-2/P masks. Samples were obtained in pairs, one sample from the left side was matched with a sample taken from the same location on the right side of each mask. One of each of these pairs was exposed to Ambergard XE-555 resin, with the other sample acting as the untreated control. Eight (8) ASTM D-638 Type V tensile test specimens were cut from each mask. Specimens were cut using a Denison Hydraulic Multipress and the appropriate cutter. Four (4) 0.25 inch by 2 inch samples were also taken from each mask for the dynamic mechanical test.

The mask samples were totally immersed in a mixture of 25% Ambergard XE-555 resin and 75% water with a sodium chloride concentration equivalent to that in human sweat (8 grams of sodium chloride per liter). The samples were kept in this mixture for 336 hours at 37 (+/- 1) degrees C. The mixture was stirred at 22 rpm to insure homogeneous exposure. The test

conditions approximate an environment inside the mask with regard to a possible ratio of sweat and resin being held at body temperature. The amount of resin relative to the elastomeric material and the exposure time far exceed any actual exposure conditions.

The mechanical dynamic analysis was accomplished by measuring the tensile elastic moduli (E') on a Rheometrics Dynamic Spectrometer (RDS-7700, Rheometrics Inc.) at 23 degrees C. Six (6) different specimens of each sample were examined. The results are summarized below (Table 4). There were no significant changes with respect to exposure to Ambergard XE-555 resin.

Table 4
Dynamic Mechanical Analysis

| Sample ID | Number of Determinations | Average E' dynes/sq cm | Standard Deviation |
|-------------------|--------------------------|------------------------|--------------------|
| M17A2 untreated | 6 | 1.32E+7 | 0.54E+7 |
| M17A2 treated | 6 | 1.15E+7 | 0.20E+7 |
| MCU-2/P untreated | 6 | 1.86E+7 | 0.46E+7 |
| MCU-2/P treated | 6 | 1.54E+7 | 0.55E+7 |
| M49 untreated | 6 | 1.77E+7 | 0.18E+7 |
| M40 treated | 6 | 1.63E+7 | 0.52E+7 |

Tensile strength was measured according to ASTM D-638 using type V tensile specimens and a strain rate of 20 in./in./min. The specimens were conditioned for 48 hours in a standard laboratory atmosphere as defined in ASTM D-618.

Elongation and Load at Break were measured and Tensile Strength at Break, Elongation at Break, and Modulus at 100% Elongation calculated. The results are summarized in Table 5. The values are an average of four (4) specimens.

Table 5
Tensile Elongation Test

| Sample | Tensile Modulus 100% Elongation (psi) | Tensile Stress (psi) | Elongation (%) |
|----------------------|---|----------------------------|-------------------|
| MCU-2/P untreated | 173.7 | 1548 | 867 |
| MCU-2/P treated | 161.1 | 1520 | 952 |
| H17A2 untreated | 148.9 | 4430 | 822 |
| H17A2 treated | 143.3 | 3981 | 794 |
| H40 untreated | 152.1 | 1693 | 910 |
| H40 treated | 145.3 | 1702 | 906 |

From the test data there is no indication that any of the rubbers tested have degraded after exposure to Ambergard XE-555 resin. The variations observed are due to the non-uniform thickness of the specimens tested.

5. NBC Survivability of the M291 Skin Decontaminating Kit

The issue of NBC survivability of the XM291 SDK was addressed by the Battelle Memorial Institute. Samples of the SDK packets and overwrapped boxes of kits were supplied by Rohm and Haas Company to be used in this testing. The following information was extracted from the Battelle report.

a. Background

Army Regulation (AR) 70-71 requires that all new items of mission-essential equipment be evaluated for NBC hardness, decontaminability, and compatibility prior to type classification. These factors are the elements of equipment survivability. This section summarizes the analysis of the SDK packet and the box in which they are to be contained for decontaminability and hardness following the Joint Services Operational Requirements (JSOR) and AR 70-71. (Compatibility was not determined during this effort).

Decontaminability is the ability of equipment to be decontaminated to a level which does not present a human hazard after exposure to chemical agent. Materials, design, and contamination control/avoidance are key factors in determining the decontaminability of an item. Hardness is the ability of an item to withstand the effects of chemical contamination and subsequent decontamination and continue to perform its mission.

Tests were conducted with chemical agents only; radiological and biological contaminants, although covered by AR 70-71, were not tested since they are not addressed in the JSOR.

b. Conclusions

Using thickened HD, both the SDK polyester/foil laminate packets and the polyester/polyethylene wrapped fiberboard box that contains 20 kits are chemically decontaminable as defined by AR 70-71.

The skin decontamination kit (SDK) does decontaminate the SDK's to about the 98% level for thickened HD (THD) when appropriately applied by trained personnel.

The overwrapped boxes of SDK's (Unit of Issue) can be decontaminated to the +99% level with DS-2 without deleterious effects on the box.

The packets were found to be completely hard to penetration or deleterious effect of THD.

The overwrapped boxes are substantially chemically and physically hard to DS-2 used as a decontaminating agent.

The tests of the SDK packet and the box were designed to worst-case standards. The use of thickened agent, high challenge densities, contamination of seams and seals, long contamination times, and immediate sampling following decontamination, all contribute to creating the most challenging scenario for the SDK packet and box (which ensures that they will also perform to standard under more likely scenarios).

6. Packet Self-Decontamination

a. Summary

Rohm and Haas Company was asked to address the issue of the number of individual SDK packets that could be decontaminated using one fresh applicator pad.

Packets were contaminated using thickened methyl salicylate (TMS) applied at the 10 g/m^2 threat level. A fresh pad from a non-contaminated packet was then used for the decontamination. The most efficient decontamination was accomplished by thoroughly rubbing the entire surface of each side of the contaminated packet for the specified period of time, making sure to utilize the entire pad surface of the decontaminating applicator pad. Following the decontamination excess decon powder was removed from the packet surface by tapping the packet on a hard surface (lab bench top) and then the packet was rinsed and surface wiped with methyl alcohol. The alcohol solution was then filtered through a 0.45 micron disposable filter and analyzed via U.V. spectrophotometry. The laboratory data are presented below (Table 6). The data suggest that the most efficient decontamination procedure would be the 30 seconds rub time which would permit one to decontaminate four complete SDK packets (8 sides) with another SDK yielding >95 percent TMS removal from each packet.

Table 6
 SDK PACKET DECONTAMINATION
 TMS Threat Level: 10 g/M²

‡ TMS REMOVAL

| SIDE | 15 SECONDS RUB TIME | 30 SECONDS RUB TIME | 60 SECONDS RUB TIME |
|------|------------------------|------------------------|------------------------|
| 1 | 81.6 | 97.0 | 99.4 |
| 2 | 83.7 | 98.1 | 98.6 |
| 3 | 96.3 | 96.4 | 96.6 |
| 4 | 94.9 | 97.5 | 98.1 |
| 5 | 95.9 | 95.9 | 97.3 |
| 6 | 95.8 | 97.6 | 92.1 |
| 7 | 95.8 | 96.8 | 76.7 |
| 8 | 96.0 | 95.2 | 70.4 |
| 9 | 98.8 | 96.8 | 71.6 |
| 10 | 96.3 | 92.1 | 40.9 |

7. Resin Delivery Rate

a. Summary

The XM291 Skin Decontaminating Kits, as delivered from PACO to Rohm and Haas, were tested for their ability to decontaminate thickened methyl salicylate (TMS) from a rough KYDEX plastic surface. It was found that the XM291 did not remove the TMS as effectively as the previous tested prototypes. The earlier prototypes removed >97 percent of the TMS whereas the XM291 removed only 80 percent. During this testing it was observed that the XM291 was delivering less resin than the earlier prototypes (0.5 g versus 1.8 g respectively). Further observation revealed that the resin in the XM291 tended to be located entirely in one half of the applicator pad and the resin appeared to clump. It was also noted that the non-woven of the XM291 applicator pad was considerably compressed which could certainly contribute to the poor resin delivery rate. The compressed non-woven is the result of one of the production steps which requires that all of the air be removed from the foil packet to prevent movement of the pad during transport and subsequent loss of resin from the pads due to vibrations.

It was found that proper resin release could be achieved through manipulation of the proper variables, i.e. resin distribution in the pad, resin clumping and compression of the non-woven. Both the resin clumping and non-woven compression could be controlled via changes in the foil packet compression step during kit production. The resin distribution could be enhanced by heat sealing the applicator pad in the center such that half of the resin load is contained in each half of the pad. These variables and changes in kit design were considered in subsequent kit design upgrades (see Section 9, Kit Design Improvements).

8. SDK Environmental Testing

Summary

The purpose of the SDK environmental test was to evaluate the stability of the XM291 Skin Decontaminating Kit packaging components. There was no reason to believe that the Ambergard XE-555 resin would be affected by these short term exposures as long as the packet remains intact. For this reason, the resin was not part of this evaluation. Long term exposure of the resin to low and high environmental temperatures are reported elsewhere (see Section C.1).

The tests were carried out in the Product Testing Laboratory (PTL) at American Electronic Laboratories (AEL), in Landsdale, PA. AEL's PTL has been accredited by the Defense Contract Administration Services (DCAS) to perform a number of standard military environmental tests. The integrity of the foil packet and overwrapped Unit of Issue was evaluated after exposure to various exaggerated environmental conditions. The basis for these tests was MIL-STD 810D. The test items consisted of twenty-five (25) overwrapped Units of Issue. The overwrap in this instance was the thicker version noted in the previous section, 4.5 mil thick as opposed to the 2.5 mil material used in the production of the 5,000 kits. In addition, sixty (60) individual decon packets were included in the testing. The five (5) tests and a brief description of their objective may be found in Table 7.

Table 7
Environmental Tests

| TEST | MIL-STD 810D METHOD | OBJECTIVE |
|-------------------|--|---|
| High Temperature | Method 501.2, Procedure I, Induced Hot. | To determine the resistance of the SDK components to elevated temperatures during their service life, either in storage or under service conditions. |
| Low Temperature | Method 502.2, Procedure I, Severe Cold. | To determine the resistance of the test items to pertinent low temperatures during their service life, either in storage or under service conditions. |
| Temperature Shock | Method 503.2, Procedure I. | To determine the effects of sudden changes in the temperature of the surrounding environment. |
| Humidity | Method 507.2, Procedure II, Induced Cyclic High Humidity. | To determine the resistance of the test items to the effects of exposure to a warm, highly humid atmosphere such as is encountered in tropical areas. |
| Salt Fog | Method 509.2, Procedure I. | To determine the resistance of the test items to the effects of an aqueous salt atmosphere. |

AEL's report (Test Report NO. 89-578-9498) indicates no major physical anomalies noted upon post-test inspection.

D. KIT DESIGN IMPROVEMENTS

Based upon the difficulties encountered during the manufacture of the 5,000 kits, improvements in the design of the SDK were identified. Concentrated efforts were undertaken to improve component materials to withstand the conditions of use and efficiency of resin delivery. The nonwoven handle, overwrap bag and polyester backing material were found to be functionally deficient and alternate material designs were needed.

1. Handle

The nonwoven material used to fabricate the handles was found to have several undesirable characteristics. The material failed to remain attached to the polyback material during many of the decontamination demonstrations/simulations. Also, the desired width was impossible to procure necessitating expensive die cutting for the Phase I production.

An alternate material, a polypropylene scrim cast on urethane film was also unacceptable because of non-adherence to the polyester backing material.

A 2 mil LDPE/48 ga. PET material was evaluated and although the sealing quality to the polyester backing material was greatly improved, tear resistance was poor and it was disqualified as a candidate. The search for an improved handle material continued into the next phase of the program (See Section I.2).

2. Center Heat Seal

The original applicator pad design included heat seals along the exterior edges of the pad to contain the Ambergard resin behind the nonwoven material. As a result of this the resin was found to collect at one end of the pad and did not provide the user with adequate resin for delivery at the opposite end near the fingertips. A center heat seal was incorporated into the design in order to provide resin delivery over the entire pad surface during decontamination. Manufacture of the applicator pad would now be accomplished by filling approximately 1/2 the resin required, heat sealing the midpoint, and completing the fill in the top half of the pad. Essential to this operation was the necessity to seal the nonwoven to the backing when resin dust is present in the designated area.

3. Polyback

During kit manufacture, it was found that the polyester backing material from 3M (Scotchpak[®]) and Archer was unable to provide an adequate bonding surface when the presence of powder "contaminated" the seal area. The addition of a center seal to the pad eliminated each of these laminates from consideration. A material that would seal to the nonwoven, regardless of the resin dust presence, was sought. After rejecting a LDPE material modified with EVA as a sealing surface, Modern Packaging provided a LDPE/PET/Surlyn laminate material that provided the strength of bond required to seal to the pad despite the presence of powder on the sealing area.

4. Overwrap Bag

The original film material used for wrapping the Unit of Issue was a structure consisting of 2.5 mil PET/Medium Density Polyethylene. This structure proved to be inadequate. During manufacture and handling, the film tore and the seals would not withstand sealing in the vacuum chamber. After reviewing several candidate materials, Jaite Packaging submitted a 4.5 mil (0.5 mil PET, 4 mil LDPE modified with 3% EVA) laminate. This material exhibited an ability to provide heat seal seams that were strong and durable.

E. SYSTEMS ENGINEERING

1. Machinery

The next phase of the program would require the fabrication of the SDK with equipment capable of production rates in excess of 1 million kits per year. As there were no off-the-shelf equipment available which could be used to fabricate these SDK, special equipment had to be designed. Accordingly, requests for proposals of equipment for Phase II were made to six different suppliers. Only one manufacturer was willing to quote on machinery for both components of the primary package, i.e., the fiberpad and the foil packet. The Rexham Corporation submitted a preliminary proposal of machinery. Initial equipment design for a commercial speed SDK production line was begun during this phase of the program in anticipation of the tight time constraints for Phase II.

a. Filler Testing

Samples of Ambergard XE-555 resin were sent to Bemis Machinery and the Bartelt Division of the Rexham Corporation. Fill test and lab reports were requested.

After 80 trials, the distribution of fill weights were surprisingly tight with a standard deviation of only 0.018 grams. The Rexham fillers utilize augers and we initially were concerned that the powder might bridge and not transfer with an auger. However, the flow promoter incorporated into the Ambergard XE-555 resin proved effective in preventing this undesirable bridging phenomena.

b. Overwrapper/ Vacuum Packaging Machinery Manufacturers

The original plan for the first phase involved the use of a Koch Multi-Vac machine available at PACO for the overwrapping of the unit of issue. As the project proceeded, the vacuum sealing chamber of this particular machine proved to be too small for the final design of the Unit of Issue. A search into the food packaging industry located 4 manufacturers of vacuum packaging machines.

Four prominent overwrapping machine manufacturers were contacted. Of these, Koch Multi-Vac and Smith Equipment indicated that they had equipment capable of vacuum sealing the overwrapped Unit of Issue.

A preliminary visit was made to Smith Equipment of Clifton, NJ to investigate the suitability of their equipment. Their proposed vacuum packaging machine (made in Austria) is similar to the Multi-Vac machine with a few extra improvements: an automatic residual film cut-off, a wider seal area and two hot wires in each of the two seal bars. The last feature is significant, in that the machine is capable of sealing through wrinkled film. Consequently, the Smith unit was selected for the final design.

2. Packaging Requirements

a. Unit of Issue

A problem with the corrugated Unit of Issue was encountered during evaluation of the 4 mil thick overwrap bag material. In an attempt to meet the criteria to eliminate billowing of the overwrap at the initial altitude criteria of 36,000 feet, the overwrapped boxes were vacuum sealed at a pressure equivalent to that altitude. When the overwrapped boxes were then exposed to sea level pressure, excessive crushing on all panels of the corrugated box occurred.

Over the course of several months the following design alternatives were investigated;

1. Addition of a Z-divider to the existing Unit of Issue.
2. Consideration of heavier test corrugated ie: 350# & 650# test.
3. Cellular partitioning within the existing Unit of Issue.
4. Reconfiguring the Unit of Issue dimensions to a more cubic design.
5. Addition of top and bottom layerboards inside the master shipper to provide protection to the unit of issue.

In our subsequent evaluations of the above, taking into account form, fit, function and cost, it was decided to include the addition of a z-divider into the existing Unit of Issue (200# test). Test results showed acceptable results at 20,000 feet of altitude, a pressure acceptable for air transport.

F. TECHNICAL DATA PACKAGE

1. Summary

Part of the contract requirements was the creation of a Technical Data Package (TDP). The TDP is an information source that defines the specifications and testing requirements necessary to manufacture M291 kits. The documents making up the TDP were the Purchase Description (PD), Special Packaging Instructions (SPI), Engineering Drawing Package, Packaging Cost Analysis, Environmental Assessment and Operator's Manual.

Much effort was expended completing this task, primarily due to the nature of the development process surrounding this project. Because of continuous evaluation of kit design effectiveness, many changes were implemented to the component structures, kit specifications and testing requirements during the period when the TDP was being assembled. Each change initiated a process of decision making, evaluation, validation, implementation, submittal, possible revision and approval affecting the assembly of many of the TDP components.

2. Purchase Description (EA-B-1657)

The purpose of a Purchase Description is to provide a source of reference to anyone needing information about the source documents, inspection and examination test requirements, and procedures or levels of acceptance for the packaging of the kit. The Purchase Description is not intended to define or dictate a specific manufacturing process.

a. Destructive Testing

Testing requirements specify function related assembly steps of the kit. After considerable discussion over many months, a list of destructive tests was agreed upon for the purpose of defining acceptable kit performance. The tests were as follows:

1. Total pad fill weight
2. Half pad fill weight
3. Pad heat seal
4. Handle heat seal
5. Overwrap heat seal seam
6. Total packet fill weight
7. Packet assembly leakage
8. Box leakage
9. Moisture content of resin in pad
10. Sorptive quality of resin in Pad

It was determined that a minimum of 2.8 grams of Ambergard XE-555 resin was required to be contained in each pad with a minimum of 1.0 grams of resin on either side of the center heat seal.

Testing for pad and handle heat seals assured that the applicator pad assembly was strong enough to withstand the rubbing required to decontaminate the skin. With strong heat seal bonds, the resin will deliver through the nonwoven material, while securely fastened to the rear of the applicator pad. Overwrap heat seal integrity testing checked the final heat seal created during the vacuum sealing process.

Submerged vacuum desiccator testing of the foil packet stressed its heat seals by increasing the internal pressure of the packet relative to the outside vacuum. As the air inside the packet expanded, tell-tale bubbles would show evidence of leakage. Also upon opening the foil packet, any moisture present inside the packet indicated evidence of leakage. Preventing exposure to environmental changes was essential to guarantee the integrity of the Ambergard resin at the time of use.

Total packet fill weight was checked to insure against resin loss during the various manufacturing steps. For example, the process of inserting applicator pads into the packets may contribute to resin loss.

Moisture content of resin and sorptive quality of resin were in-process laboratory tests. These test insured that the quality of the resin had not been compromised by the process of warehousing or kit manufacture.

b. Examination

Conformance to the specifications for the SDK are primarily determined by examination of the various assemblies produced during kit manufacture. Examination is conducted at the following assembly stages of kit fabrication:

- 1) Applicator pad sub-assembly.
- 2) Packet assembly, and
- 3) Skin decontaminating kit assembly.

Each of these have acceptance criteria based on 3 categories: dimension, function, workmanship. The packaging of the Skin Decontaminating Kits into Units of Issue and master shippers are examined for correct markings, missing components or kit quantities not as specified. In general, the Level II testing is selected to provide the assurance that defect levels would be minimized and quickly corrected.

3. Special Packaging Instructions (P5-77-2301)

This document serves as a reference for identifying the Military Standards that govern the intermediate packaging and final packing steps necessary to prepare the Units of Issue for shipment.

The SPI covers Level A and Level B packing of four Units of Issue per chosen shipping container. The help of CRDEC personnel was invaluable due to the number of tasks at hand. Specifically, their experience in the field of Packaging Engineering quickly identified appropriate Military Standards impacting the shipment of the SDK.

Enclosed in the SPI are dimensional requirements of the shipping containers, exterior marking reference documents, quality assurance reference documents, unitization reference, and unit pack logistics data.

4. Drawings

The development of the drawing package for the SDK evolved over many months. Initial Level 3 drawings for the Unit of Issue and kit were developed during the 8th month of Phase I and submitted, followed by 11 additional drawings provided during the 11th month. The level of detail at this time centered on dimensional aspects of the various kit assemblies and component impressions to make the kit. The drawing package consisted of the following:

| | |
|-------------------|--|
| Drawing 5-77-2301 | Box of Twenty Decontaminating Kits, Skin: M291 |
| Drawing 5-77-2302 | Overwrap |
| Drawing 5-77-2304 | Box |
| Drawing 5-77-2305 | Decontaminating Kit, Skin: M291 |
| Drawing 5-77-2306 | Pouch |
| Drawing 5-77-2307 | Packet |
| Drawing 5-77-2308 | Packet Assembly |
| Drawing 5-77-2309 | Applicator Pad Sub-Assembly |
| Drawing 5-77-2310 | Handle |
| Drawing 5-77-2311 | Applicator Pad |
| Drawing 5-77-2312 | Polyback |
| Drawing 5-77-2314 | Box Insert |
| Drawing 5-77-2315 | Resin |
| Drawing 5-77-2320 | Pouch Impression |
| Drawing 5-77-2321 | Packet Impression |

Hampering the progress of the Drawing Package was an effort to perform kit design evaluation and upgrade. Evidence of inadequate design characteristics led to a significant number of options when considering materials needed, alternate suppliers and alternate design options.

During this time, equipment manufacturers were being sought for supplying a manufacturing system capable of producing the SDK. Also, uncertainty was prevalent about material structures proposed for the handle, polyba and overwrap.

This task was further complicated by the need for more technical information about material components. Vendors were required to supply breakdowns of their laminate structures. How this should be depicted on the drawings was a subject of a number of revisions.

In the notes section of each of the component drawings, functional characteristic data describing the necessary attributes of each material component had to be constructed. Minimum and maximum specification limits had to be established for each material component. The difficulty in completing these drawings was caused by not having an established data base of component production. As described elsewhere throughout this report, most packaging component materials were specially produced to satisfy unique performance requirements of the SDK. With the help of the vendors, best estimate physical data attributes were obtained primarily using ASTM test methods.

5. Operator's Manual

Since the SDK will be used both for training purposes and following an actual chemical attack, the operator's manual covers instructions applicable to both. The operator's manual was published as a Joint Service Manual. Rohm and Haas employed the services of Koslow Technologies Corp. (KT Corp.) to provide the production capabilities for writing, illustrating, editing and preparing the camera ready mechanicals of the manual.

The Final Draft Equipment Publication (FDEP) of the Operator's Manual for the M291 was submitted in accordance with the terms of this contract. A copy of the Operator's Manual cover may be found in Figure 14.

G. Leasehold Improvements

1. Summary

To prepare for the production phase of the project, Paco selected a site at 1200 Paco Way. A 7500 square foot area was created by demolishing a number of packaging lines. The space was intended to contain a small warehouse, resin filling room, secondary packaging room and Quality Testing Lab. The task of constructing the facility included activities such as the installation of HVAC (heating, ventilation, air conditioning), electrical service, pre-fabricated walls, drop ceilings, epoxy floor coating, dust collection and lighting.

Figure 14

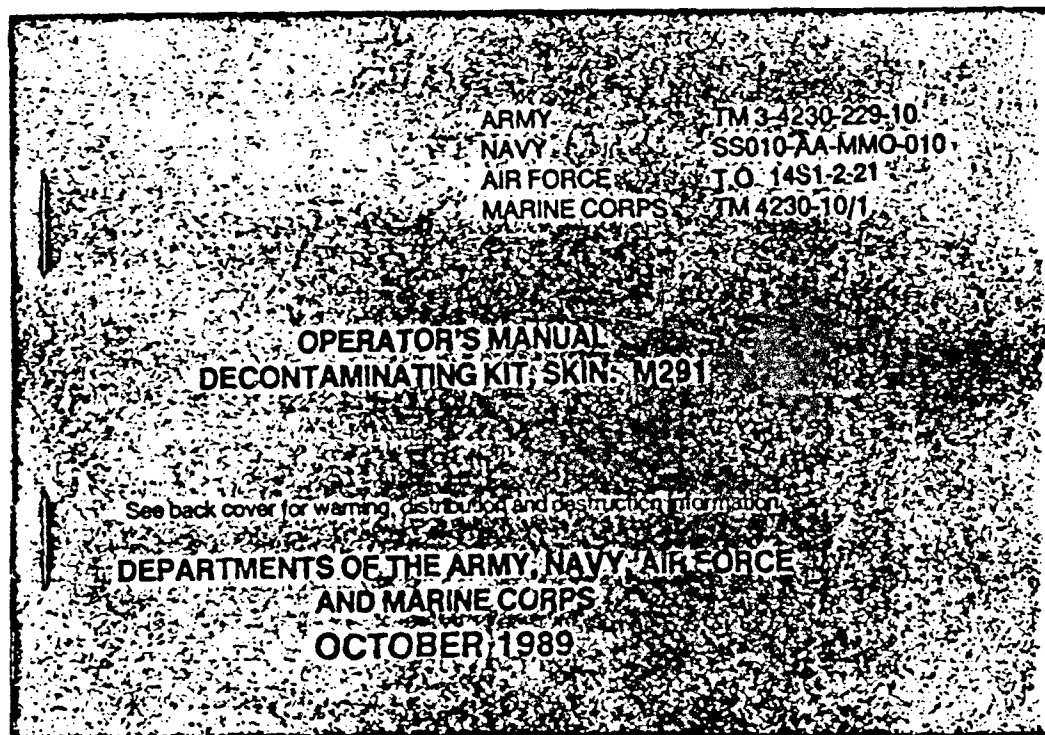

The process for determining which construction vendor to choose was as follows:

- (1) Paco Engineering created a statement of work based upon a specific leasehold improvement need.
- (2) Companies were solicited to respond with their best estimate of cost and method of approach.
- (3) Choice was determined based upon cost, Small Disadvantaged Business status and the ability to satisfactorily meet the aggressive time schedule proposed.

Leasehold Improvement contracts were awarded to the following vendors:

| <u>Type of Work</u> | <u>Vendor</u> |
|--------------------------|--------------------------|
| Demolition | M. Shine Inc. |
| Painting * | Thomas & Sons |
| Electrical | Gilligan & Nardini, Inc. |
| HVAC | Worrell Bros., Inc. |
| Pre-Fabricated Walls | Modulex, Inc. |
| Plumbing, Compressed Air | Ronald Veiss Co. |
| Epoxy Floors | Stonehard Co. |
| Drop Ceilings | Island Acoustics |
| Dust Collection | Donaldson/Torit |

* Small Disadvantaged Business

The improvements to the facility was completed on schedule prior to the receipt of the manufacturing equipment from Klockner-Bartelt (formerly Rexham Corporation).

H. Manufacturing System Installation

1. Summary

When the Rexham Corporation agreed to accept the challenge of manufacturing automated equipment to produce M291 kits, a major step towards full scale production was taken. Rexham Corporation representatives were the only original equipment manufacturers that responded positively to the Rohm and Haas/Paco proposal, thus indicating that with time and effort, they could meet all requirements.

Prior to initiation of Phase II, engineering and design work was undertaken in anticipation of the contract continuing. By early December, 1988, when the government exercised the Phase II option, two completely integrated manufacturing lines were ordered, each capable of nominally producing 750,000 kits per year, operating on a 2 shift/5 day basis.

The list of primary equipment is as follows:

| <u>Item</u> | <u>Function</u> |
|---|-------------------------------|
| Applicator pad machines, left hand, Serial #'s 3323L & 3335L | Forms applicator pad assembly |
| Model D auger fillers, Serial #'s 150508, 150509, 150510 & 150511 | Dispenses Resin |
| High speed checkweigher conveyors | Verifies fill weight |
| Bartelt Model IM7-14, Serial #'s 3324 & 3336 | Forms packet assembly |
| Bartelt Model IM-SP kit pouch machine, Serial #'s 3325L & 3337L | Forms pouch assembly |

During the months leading up to the scheduled November, 1989 First Article Test (FAT), Klockner-Bartelt representatives were on site at Paco performing installation, check out and final set up to meet the specifications of the M291. Safety measures were demonstrated, mechanical training, equipment modifications and installations kept two Klockner-Bartelt technicians stationed at Paco for the better part of two months. The on-site support by Klockner-Bartelt was evident even during the FAT for Line #1.

In an effort to adopt a mode of continuous improvement in the areas of manufacturing the M291, Paco kept in close contact with Klockner-Bartelt, documenting any changes made to the equipment. Reasons for change vary, but for the most part, dimensional changes to the TDP necessitated heat seal bars and cooling bars be corrected to allow for maximum tolerance. Auger tooling was identified to best provide accurate Ambergard ZE-555 resin dispensing, which was aided by the Hi-Speed Checkweigher feedback control module.

Changes in resin density within the product hoppers are evident in the weights recorded on the checkweigher. If a weight trend develops, then the feedback control unit changes the auger (revolutions per minute) speed. This feature automatically maintains consistent resin weight in each applicator pad as needed.

Calibration of instrumentation deemed vital to the capabilities of the Klockner-Bartelt equipment was performed by Westinghouse Engineering Services Division.

All instrumentation was calibrated and found to be operating within acceptable ranges of accuracy. A schedule of calibration was recommended and was incorporated into the quality assurance plan.

I. MATERIALS DEVELOPMENT AND KIT DESIGN UPGRADE

1. Summary

Further materials development was performed at this stage of the contract to evaluate candidate materials which enhanced kit performance and/or improved manufacturing capabilities. Earlier manufacturing efforts were basically hand assembly operations with little regard for eventually engineering a complete system of equipment. Components purchased for kit manufacture during Phase I were found to be impossible to procure in the widths and style needed to be compatible with the Klockner-Bartelt equipment system.

The kit design upgrade segment covered the cost of procuring those successfully tested materials identified during Materials Development, reducing to practice the specific changes by preparing functional samples, and developing special tooling to provide the samples. These samples were utilized in configurational management audit reviews to support engineering change proposals.

2. Handle

As stated in Section D.1, the original material selected for the handle of the applicator pad assembly was rejected. The reason for rejection was due to a poor resistance to tearing in the cross direction. A number of suppliers in the plastics industry were canvassed and the decision was made to evaluate a film provided by the Archer Company. This film contained nylon, which is a primary advantage when faced with a requirement for strength and durability.

Because of the availability of this film, and the deadline to provide a deliverable quantity of 20 kits for field testing fast approaching, Paco purchased and used this 5 layer film laminate for the submission. At the time, an olive drab colored film was not available and permission was granted to use a clear laminate for one time only. Archer gave assurance that the olive drab pigment would not change the functional characteristics as opposed to the clear material. Reports from the Army were favorable about the Archer handle material. Tear strength, high bond strength to the polyback and the ability to purchase this material in a 1.5 inch roll width helped select the film as the material of choice for this function.

3. Polyback

Upon closer evaluation of the polyback laminate provided for earlier deliverable kits, Paco representatives defined an inherent defect in the bond strength between layers of the materials. The layer of Surlyn was poorly laminated to the interior polyester layer and might delaminate during the decontaminating process. DRG/Modern Packaging engineered a change to their manufacturing process by adding a polyethyleneamine coating to a low density PE layer between the Surlyn and polyester. The resulting material provided the characteristics necessary to meet the intended function.

4. Pouch Material Alternatives

Cost reduction was mandated as being an issue surrounding the Tyvek kit material provided by the Tolas Company. This item is a high priced component, and the cost reduction issue was worthy of investigation. The essential function of the Tyvek pouch was to provide a quiet durable material for carrying packet assemblies and providing printed informative instructions for use of the kit.

The search process led to nothing that was deemed acceptable. Structures from the Archer Company were rejected because of the noise level, possibly compromising a soldier's position.

CRDEC enlisted the help of the package engineers at the Tobyhannah Testing Facility for a Tyvek replacement specified in military or commercial standards, to no avail. At this time, major equipment was being designed and a kit material decision was needed. The material provided by Tolas (Tyvek) was chosen and the effort to replace this item ceased.

J. AMBERGARD XE-555 RESIN GRINDING

1. Summary

During Phase II of this contract a sufficient quantity of Ambergard XE-555 resin was prepared in order to: (1) demonstrate the ability to grind and blend at the 200 gallon scale, (2) prove out and validate the large scale packaging equipment line installed at PACO Pharmaceutical, and (3) produce sufficient M291 SDK's to satisfy FAT.

The Ambergard XE-555 resin supplied during the first phase of Contract DAMD17-87-C-7116, as well as the earlier Contract DAMD17-85-C-5200, was prepared in a 30 gallon Attritor (grinder/blender unit) located at Union Process in Akron, Ohio. However, in order to demonstrate the capability to produce sufficient Ambergard XE-555 resin to supply several million M291 SDK's per year, it was necessary to scale-up this grinding/blending operation from the 30 gallon to the 200 gallon scale, the largest size equipment of this type available.

Presented here is a summary of the work done to scale up the grinding of Ambergard XE-555 resin from a 30 gallon Attritor Mill to a 200 gallon Attritor Mill and the key results obtained. Despite setbacks along the way, we were successful in achieving the capability to grind Ambergard XE-555 resin in a 200 gallon Attritor Mill. Moreover, compliance with cGMP and a continual improvement in grinding yields have been demonstrated.

2. Grinding Campaign Using a 1.5 Gallon Mill

Ambersorb XE-555 resin was ground in the pilot plant's 1S Attritor Mill using permutations of 300, 325, and 350 rpm, and 10, 15, 20, 25, and 30 minute grind times, and various methods of raw material component introduction. The grinding media used was 3/16" stainless steel ball bearings. This media is identical to media available at Union Process for use in their 200 gallon mill. Previous grinding of Ambergard XE-555 resin was done with 1/4" media in Union Process' 30 gallon mill. Our objective was to scale up to the 200 gallon mill using the available 3/16" media, if possible.

It was found that we could produce acceptable Ambergard XE-555 resin in the 1S Attritor Mill with 3/16" media, by adding all of the components together, and grinding at 350 rpm for 20 to 30 minutes.

Early work indicated that our method of particle size determination by Malvern Particle Size Analysis required improvement, because of high test to test variance. Using designed experiments, the variance was greatly reduced by revising the method of sample preparation.

3. 200 Gallon Mill with 3/16" Grinding Media & all-at-once Raw Material (RM) Addition

Our attempts to repeat the results demonstrated in the 1S Attritor mill failed in the 200 gallon mill at Union Process. Of the 1600 pounds of Ambergard XE-555 Intermediate resin loaded into the mill, only 1051 pounds were recovered as product. Excessive caking of powder on mill walls prevented mill cooling, and resulted in moisture loss as steam and pressure buildup in mill. The three factors that had been changed since Ambergard XE-555 resin was ground successfully in the 30 gallon mill at Union Process in 1986, were the media size (3/16" vs. 1/4"), the method of raw material addition (all at once vs. dry components, then wet component), and the size of the mill (200 gallon vs 30 gallon).

4. Grinding Studies Utilizing a 30 Gallon Mill

To supply PACO with sufficient resin for first article testing, 1217 pounds of good quality Ambergard XE-555 resin were produced in Union Process' 30 gallon mill with 1/4" media by the component addition method. A standard production rate of 15 batches per 8 hour day was demonstrated.

A designed experiment was conducted in the 30 gallon mill to determine what factors should be changed to allow us to grind Ambergard XE-555 resin in the 200 gallon mill successfully. Specifically media size (1/4" vs. 3/16"), grind time (18 minutes vs. 36 minutes), and addition method (all at once vs. component) were examined. It was determined that the media size influenced product quality the most. Energy balance calculations showed that the larger media was more effective in scraping the mill walls, which allowed greater heat transfer to occur. As a result, less heating of the resin occurred, and consequently less moisture was lost as steam. Based upon these results we recommended the purchase of 6000 pounds of 1/4" stainless steel media for the 200 gallon mill.

5. 30 Gallon Mill Production

Additional quantities of Ambergard XE-555 resin were made in the 30 gallon mill to supply PACO with resin for First Article Testing.

6. 200 Gallon Mill Production with New 1/4" Grinding Media

Tests were run with the new 1/4" media in the 200 gallon mill. 1000 pounds of Ambergard XE-555 Intermediate resin yielded 940 pounds of Ambergard XE-555 resin. The last drum of the fifth grind approached the solids specification; compared to the last drum of the first grind using the 3/16" media. It was recognized that process optimization should entail improved mill cooling to allow continuous grinding without heat buildup in the mill.

7. 200 Gallon Mill Process Optimization

Experiments were conducted to determine the minimum amount of media required to achieve adequate grinding. It was found that 5000 pounds was acceptable. It was also found that emptying the mill with 15 psi nitrogen at moderate flow rates (40-60 standard cubic feet per hour) with low speed agitation allowed the mill to cool and permit continuous grinding, without heat buildup, nor loss of moisture as steam. The standard grinding conditions were thus established to be:

1. 200 gallon mill filled with 5000 pounds of 1/4" stainless steel media
2. Add dry components, grind at high speed for 10 minutes
3. Add wet component, grind at high speed for 5 minutes.
4. Increase pressure and flow of nitrogen to mill, agitate at low speed and empty mill for 30 to 40 minutes.

From these standard conditions we were able to establish controls to insure that we could operate under cGMP. Standard Operating Procedures were written, training was conducted, and audit procedures were established and conducted. Ambergard XE-555 resin produced during this time frame was qualified as acceptable under cGMP. The Ambergard XE-555 resin produced in this final grinding campaign was utilized for the FAT on Line 2 at PACO.

In order to demonstrate an acceptable resin delivery rate with material produced in the 200 gallon Mill versus that produced in the 30 gallon Mill, PACO produced SDK's containing Ambergard XE-555 resin from each Mill. Included in this study was the effect of the nonwoven air permeability on the resin delivery rate. The results shown in Figures 15 and 16 suggest no significant difference in resin delivery rate between Ambergard XE-555 resin produced in the 30 gallon Mill versus the 200 gallon Mill. The data also show acceptable resin delivery rates for applicator pads manufactured with applicator pads having air permeability values of 12 inches and 18 inches of water (Frazier Test, ASTM D737). The values presented represent averages of 3 simulated decontaminations of the hands.

K. PROCESS EQUIPMENT VALIDATION

1. Summary

This work segment covered endeavors related to the validation of the production process. In this activity, the repeatable quality of each machine subsystem was evaluated. All operating parameters including machine speed, pressure, time and temperature were challenged, analyzed, and qualified. The acceptable range and tolerances of the operating parameters were then established. The major quality issues addressed were:

1. Applicator pad heat seal
2. Handle heat seal
3. Applicator pad fill weight
4. Half pad fill weight
5. Packet leakage
6. Packet fill weight
7. Packet thickness
8. Overwrap integrity

This activity also involved the validation of quality assurance testing and methods, i.e. checkweighers and calibration of associated equipment.

Figure 15
NONWOVEN: 0.12 AIR PERMEABILITY

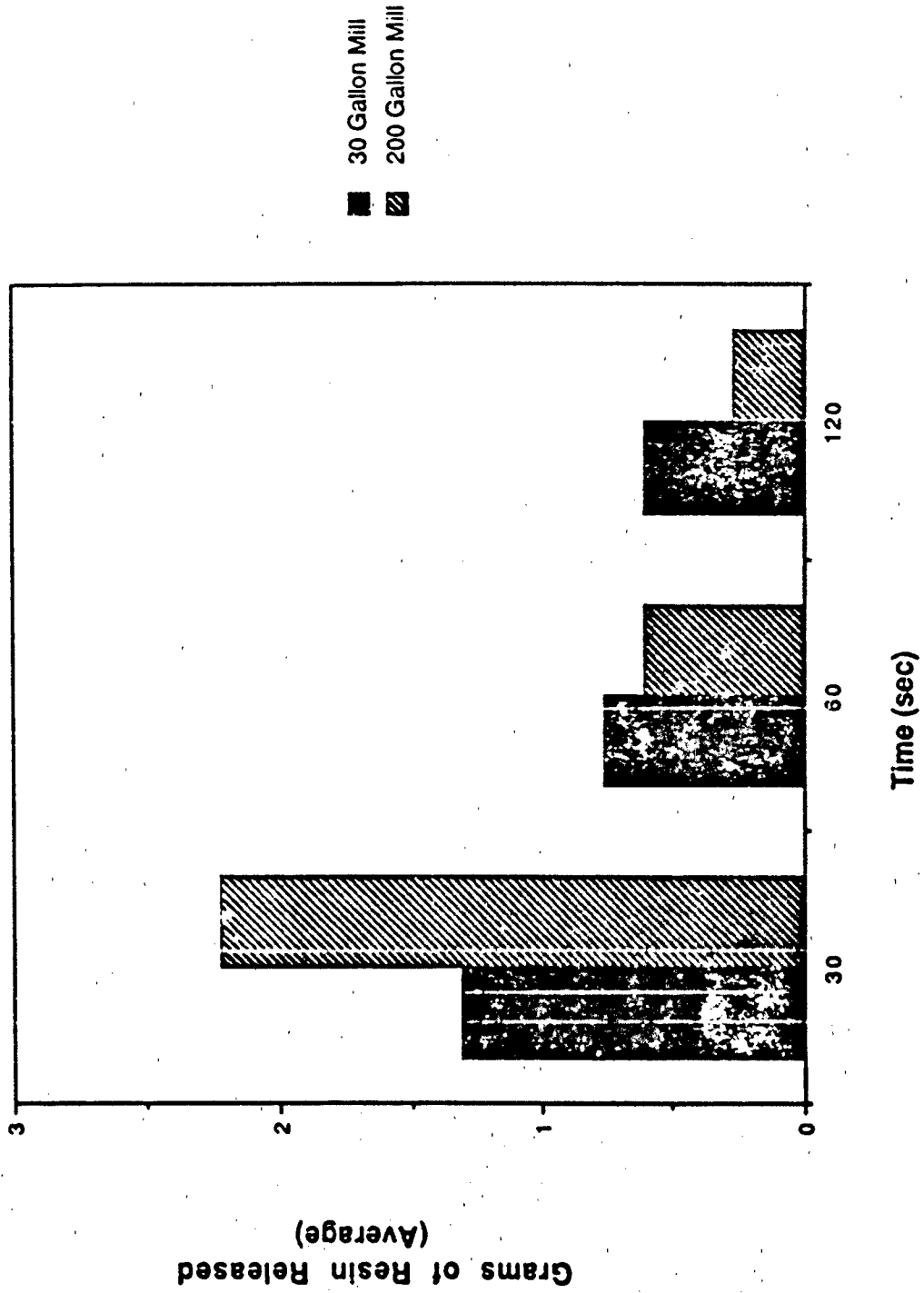
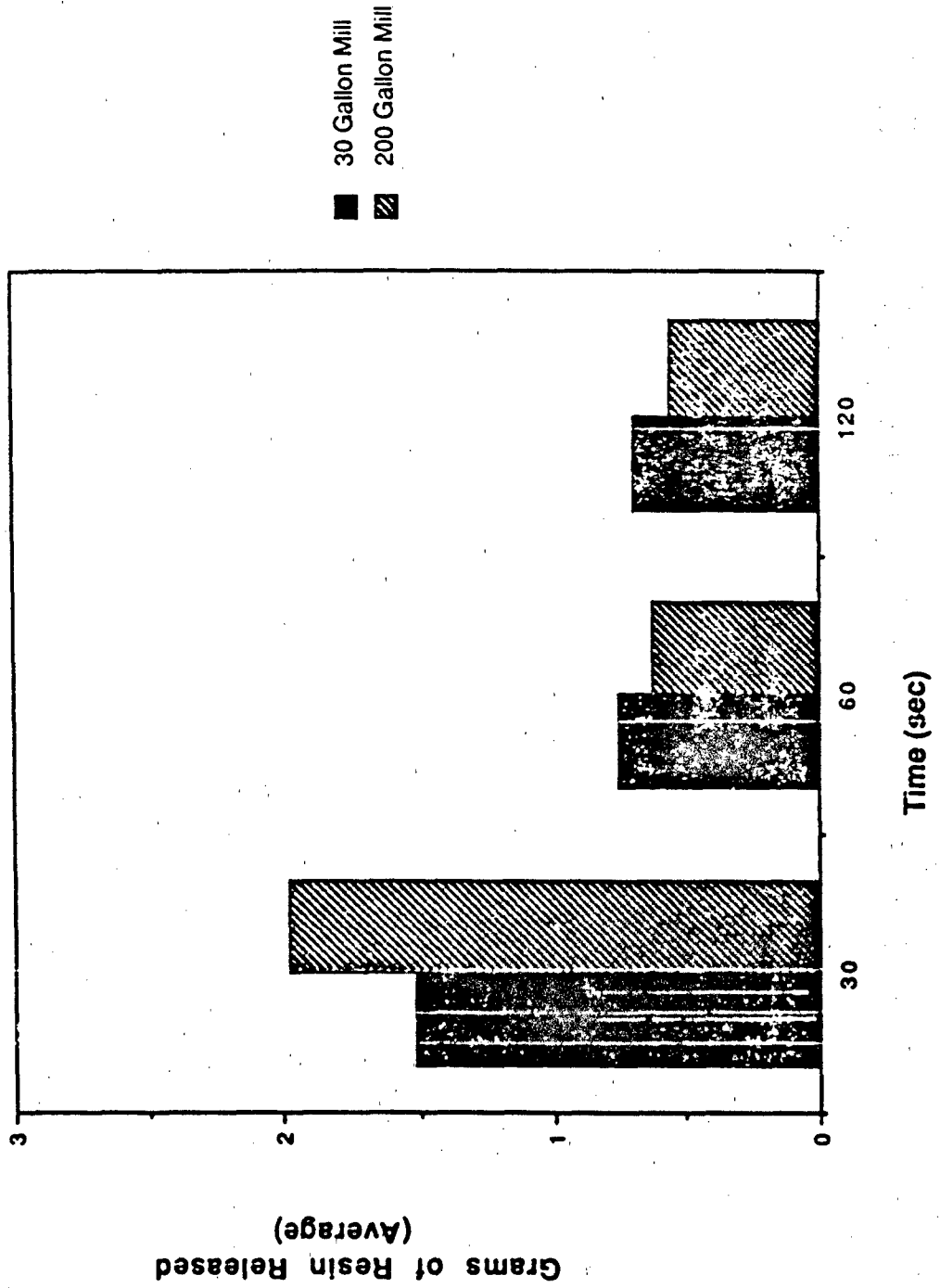

Figure 16
NONWOVEN: 0.18 AIR PERMEABILITY



L. CONFIGURATIONAL MANAGEMENT PLAN (CMP)

1. Summary

The Configurational Management Plan (CMP) establishes the organization and procedures that shall be employed by Rohm and Haas Company (prime contractor) to maintain and control the configuration of the M291 Skin Decontamination Kit (SDK) during manufacture and testing. The CMP also defines the liaison between the prime contractor and the procuring activity, U.S. Army Medical Material Development Activity (USAMMDA) and between the prime contractor and the SDK initial production manufacturer (subcontractor), PACO Pharmaceutical Services, Inc. The CMP was developed in accordance with the format and content requirements of MIL-STD-1456.

At Rohm and Haas, the M291 SDK Principal Investigator (PI), was assigned overall management responsibility for performance and product delivery under this contract. This management responsibility included the institution and monitoring of a M291 SDK configuration management (CM) program. This CMP was the guiding directive for M291 SDK configuration management during the contract period of performance. The PI interfaced directly with the USAMMDA contracting Officer's Representative (COR) in all M291 SDK technical matters, including CM. A Rohm and Haas M291 SDK Configuration Manager was designated by the PI.

Figure 17 is an organizational relationship diagram showing the interfaces between Rohm and Haas, the USAMMDA, and the M291 SDK initial production subcontractor, PACO Pharmaceutical Services, Inc.

A M291 SDK Configuration Control Board (CCB) was established at Rohm and Haas Company. Membership of the CCB consisted of representatives from Research and Development (R&D), Contracts, Engineering, and Quality Assurance. All members of the CCB were appointed by the PI. Figure 18 shows the CM organization within Rohm and Haas and the makeup of the M291 SDK CCB.

Figure 19 shows the CM organization that was established at PACO, including the CM Advisory Board that was established to assist the sub-contractor Configuration Manager in the evaluation of Engineering Change Proposals (ECP's) within the PACO organization.

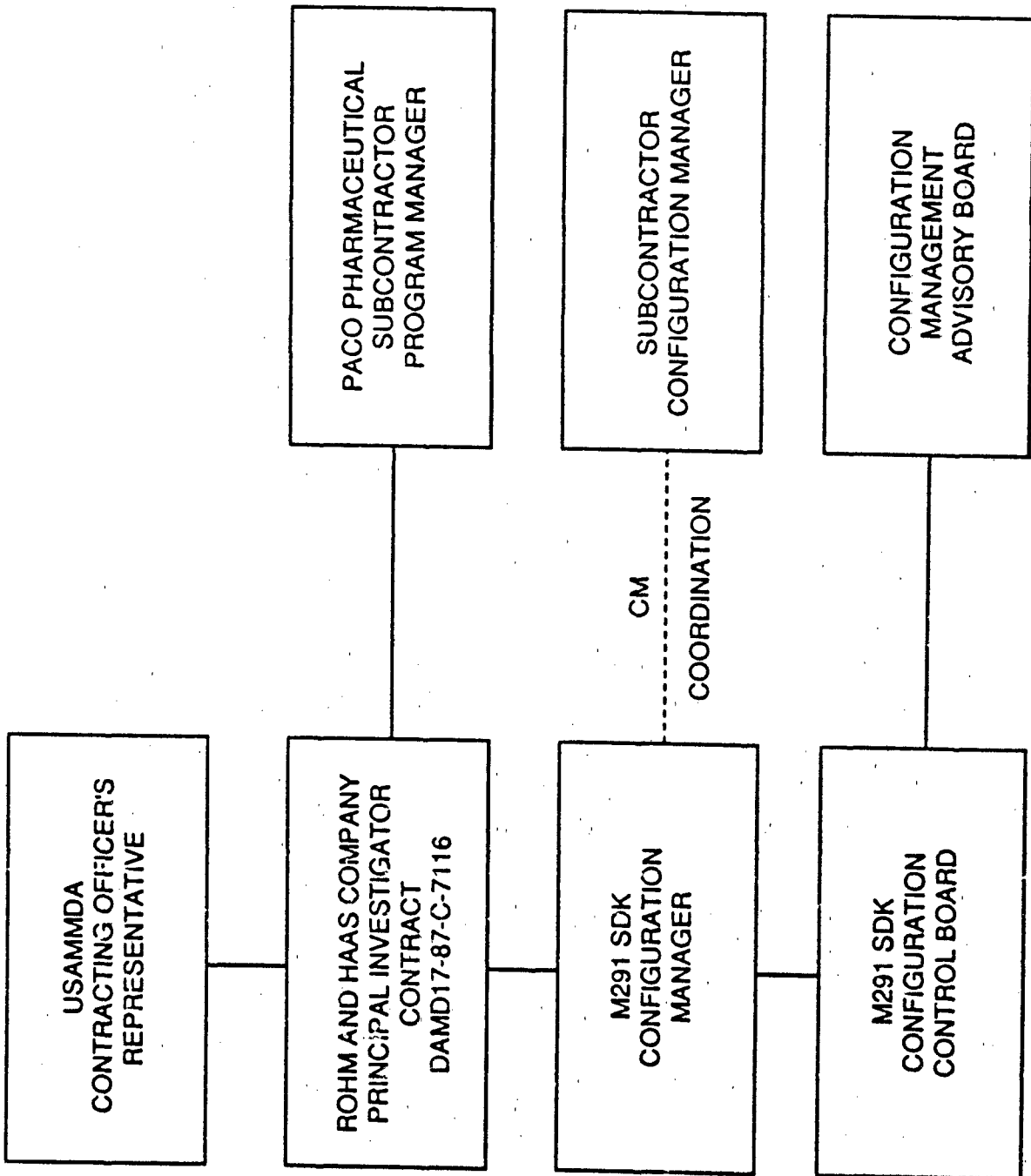

Figure 17. Contract DAMD17-87-C-7116 Configuration Management Organizational Relationships

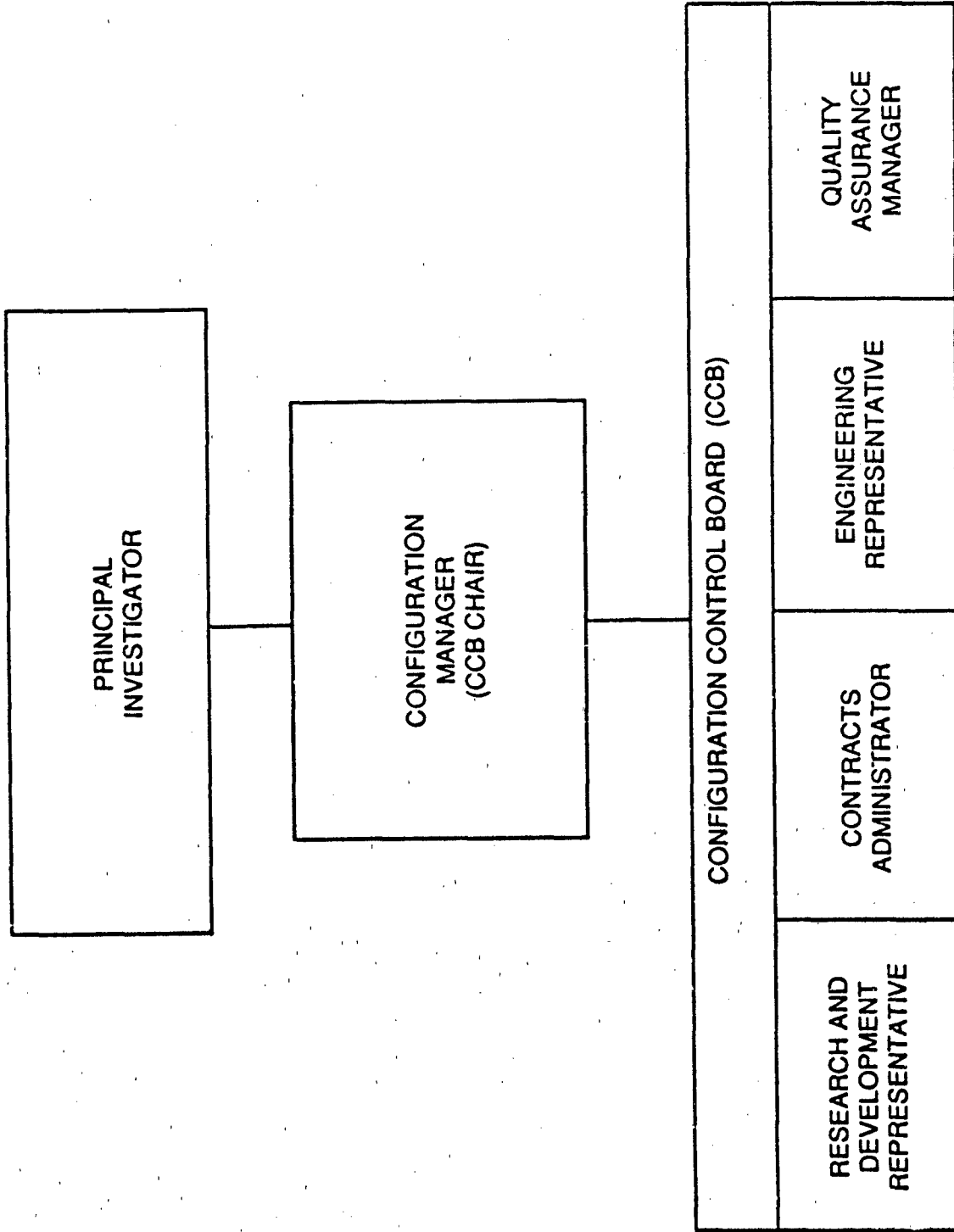

Figure 18. Rohm and Haas M291 SDK Configuration Management Organization

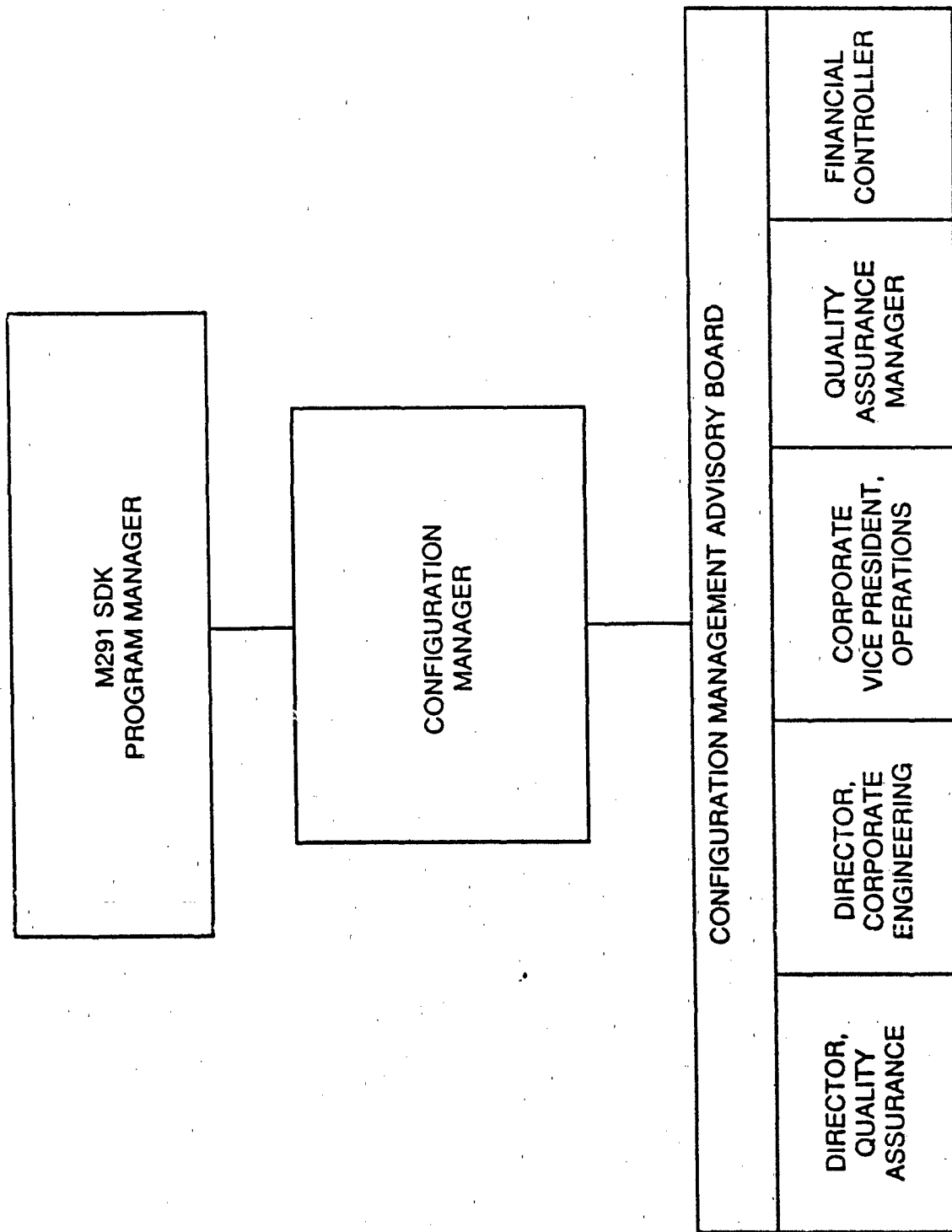

Figure 19. PACO Pharmaceutical M291 SDK Configuration Management Organization

As a requirement of the Configurational Management Plan, a 100% dimensional inspection of the Technical Data Package dimensions was required to ensure that the drawings accurately reflect the M291 Kits that were produced during the First Article Test. A second requirement was to write the First Article Test Procedures to validate the Purchase Description EA-B-1657. The test procedures were written to stress the initial testing beyond the normal requirements.

M. ENGINEERING CHANGE PROPOSALS (ECP's)**1. Summary**

During Phase II, thirteen (13) Engineering Change Proposals and their corresponding Notices of Revision (NOR's) were submitted as a result of a more in-depth review of the drawings and other documents in relationship to the actual manufacturing and testing processes. The requests for ECP approval were as follows:

Numbers in parentheses represent the document of the TDP affected.

RH001-(5-77-2307) - Packet Notch dimension and tolerance - changed side notch location and dimensional tolerances of all the notches.

RH002-(5-77-2307) - Packet notch depth - change notch depth and tolerances - *(Abandoned as a result of equipment re-tooling)

RH003-(5-77-2308) - Packet thickness - Decrease minus tolerance, reflecting improved process control.

RH004-(EA-B-1657) - Sorptive Quality of resin - revised sorptive test procedure to identify 0.1 N iodine solution and add the use of iodine calibration solution.

RH005-(5-77-2308) - Packet top seal dimension - increased tolerance on seal width to agree with DWG. 5-77-2307.

RH006/RH007 (5-77-2310, 2311) Package component attributes address notched tear and air permeability parameters.

RH008-(5-77-2309, 2311, 2312) Applicator Pad assembly increased end heat seal widths, and overall length of the pad.

RH-009-(5-77-2301) Bar Codes were revised on squad box and relocated.

RH-010-(EA-B-1657) Overwrap Leakage Test method expanded to include specific angles for the test specimen to be presented to the water, and the maximum area to be covered by the angular device.

RH-011-(5-77-2302) Pouch impressions changed the amount of adhesive in material description and changed spec values to reflect vendor's actual values.

RH-012-(5-77-2301) "H" taping added specific taping method to reduce possibility of overwrap bag failure.

RH-013-(5-77-2302) Overwrap bag width/heat seal width tolerances were expanded.

N. SAFETY ENGINEERING

1. Manufacturing Facilities

The building of the facility at 1200 Paco Way and the manufacturing of the equipment were performed with safety measures being a major priority. All training of personnel centered around the safest and most efficient way to perform the tasks. Lab safety was built into the layout of the area, with ergonomics being considered. Incineration of packaging material scrap was implemented and performed at Rollins, Inc. These measures and many others consisted of the Rohm and Haas/Paco effort to provide as safe an operation as possible..

Major pieces of equipment were installed by the service technicians of the respective companies to insure proper wiring and operation prior to release to Paco. Dust collection was provided to remove and collect resin dust caused by the manufacturing process. Employee exposure to excessive amounts of airborne particles was of primary concern. Plexiglas[®] guards were interlocked with the machine stop switch to prevent any machine movement while the guard is opened. Preventative maintenance was implemented to take a proactive approach to eliminate hazards.

A Safety, Health and Environmental (SHE) review was performed by a Rohm and Haas representative and the facility was deemed acceptable prior to the First Article Test in November, 1989.

2. Ambergard XE-555 Resin

Testing of Ambergard resin for flammability was necessary due to the requirements of equipment manufacturing safety decisions. Rohm and Haas contracted with Fenwal Inc. to perform a series of tests. This was to simulate conditions that would cause an explosion or ignition of the resin. After testing, the explosibility of Ambergard XE-555 resin was considered minimal, with a classification of ST-1 (least hazardous) being assigned. The minimum explosive concentration (MEC) was determined to be 170 g/m³ and the minimum oxygen required for combustion, 18%.

O. PRODUCT ASSURANCE/QUALITY ASSURANCE PROGRAM PLAN

1. Summary

During the period covered by Phase II of the contract, material specifications were determined, Standard Operating Procedures were finalized to evolve into the Quality Assurance Program Plan and material and product test methods were agreed upon.

2. Material Specifications

Considerable effort was expended to pursue attribute values at material suppliers to provide justification data for setting specification requirements.

In pursuit of this goal, PACO set out on a certification program with all its component vendors to set in place the structure, format, and purpose of the desired certifications, along with collection of the necessary data.

3. Quality Assurance Program Plan (QAPP)

Contract modification required preparation of a Quality Assurance Program Plan (to replace the previously required Inspection System Program Plan) requiring a more comprehensive effort on the part of Rohm & Haas and PACO to address the overlapping requirements of GMPs, the requirements of the TDP, and the Standard Operating Procedures of PACO and Rohm and Haas Company.

As previously noted, the M291 SDK has been determined to be a medical device as defined by the Food and Drug Administration (FDA). The manufacture of medical devices is regulated by the general controls applicable to all such devices and specific standards which apply to particular devices or classes of devices. The general controls for the manufacturing of medical devices are published in 21 CFR 820 (Code of Federal Regulations).

Every finished device manufacturer is required to prepare and implement a quality assurance program that is appropriate to the specific device manufactured and consists of procedures adequate to assure that the following functions are performed:

1. Review of production records;
2. Approval or rejection of all components, manufacturing materials, in-process materials, packaging materials, labeling, and finished devices; approval or rejection of devices manufactured, processed, packaged, or held under contract by another company;

3. Identifying, recommending, or providing solutions for quality problems and verifying the implementation of such solutions;
4. Assuring that all quality assurance checks are appropriate and adequate for their purpose and are performed correctly.

The Quality Assurance Program Plan (QAPP) was submitted to DCASMA Phi-GAQC, reviewed and accepted.

P. FIRST ARTICLE INSPECTION PROCEDURE

1. Summary

As required, the First Article Inspection Procedure was prepared and submitted prior to the beginning of the first article test. The First Article Inspection Procedure was designed to ensure that the M291 Skin Decontaminating Kits meet the requirements of the Purchase Description EA-B-1657. For each of the two manufacturing lines that the procedure was used for, 20 Units of Issue were required. The First Article Test Procedure lists the requirements and purchase description paragraph reference, the sample size, accept/reject criteria, and the test paragraph. The accelerated aging was done at 48 degrees C for 24 hours while the cold storage was done at -54 degrees C. The Unit of Issue conditioning was done by AEL Defense Corporation with a DCAS-QA specialist signing off on the test report. The results of the testing were reported in the First Article Test Reports.

Q. FIRST ARTICLE INSPECTION REPORT

1. Summary

A First Article Inspection Report (FAIR) was prepared and submitted, documenting the results of the pre-production tests and examinations outlined in the First Article Inspection Procedure. This report shows completion of the inspections performed and the results of those inspections to demonstrate that the first article M291 SDK's conform to the applicable technical requirements.

2. First Article Test-Paco Manufacturing Line # 1

The First Article Test for Line #1 was conducted on November 7 through 9, 1989. The purpose of the run was to validate the Technical Data Package on the first of two manufacturing lines installed at Paco. Representatives of Rohm and Haas Company (contractor) as well as the US Government (USAMDA, CRDEC,

AMCCOM, and DCASMA) were present during testing.

Data was collected in accordance with the First Article Inspection Procedure document dated October 12, 1989. In addition a 100% dimensional inspection was carried out as specified in the Configurational Management Plan dated August, 1989.

Several deficiencies were noted during the test run by the attendees present. A Quality Deficiency Record was issued by the DCAS-QAR. The deficiencies noted during the run were as follows:

1. Drawing # D5-77-2306, The Tyvek pouch side seal was under the minimum dimension of 0.25 inches. Passed First Article Retest.
2. Drawing # D5-77-2308, The Foil Packet top seal was out of specification. Approval of ECP No. RH005 resolved the issue.
3. Drawing # D5-77-2309, The applicator pad side seal dimension. Passed First Article Retest.
4. Drawing # D5-77-2307, The notch depth was out of specification. Passed First Article Retest.
5. EA-B-1657, Handle Heat Seal, Paragraph 4.4.4.6. Handles failed the hang test.
6. Certification not on hand for material used in the First Article Testing. Vendors to provide certification after they have gained reasonable experience with the materials.

A conditional approval was given for manufacturing line # 1 with full approval being withheld until the second manufacturing line fully passes its First Article Test.

3. First Article Test-Paco Manufacturing Line # 2

The second First Article Test was conducted on April 18, 1990. The purpose of the run was to validate the Technical Data Package on the second manufacturing line installed at Paco. Representatives of Rohm and Haas Company (contractor) as well as the US Government (USAMMDA and DCASMA) were present during testing.

The First Article Test Results as outlined in the First Article Test Report on the second manufacturing line demonstrate the successful producibility of the M291 Skin Decontamination Kit.

The attached photographs (Figures 20, 21 and 22) show the final M291 applicator pad, loaded foil packet and the complete M291 Skin Decontaminating Kit, respectively. Figure 23 is a schematic of the Unit of Issue and its components.

DECONTAMINATING KIT, SKIN: M291

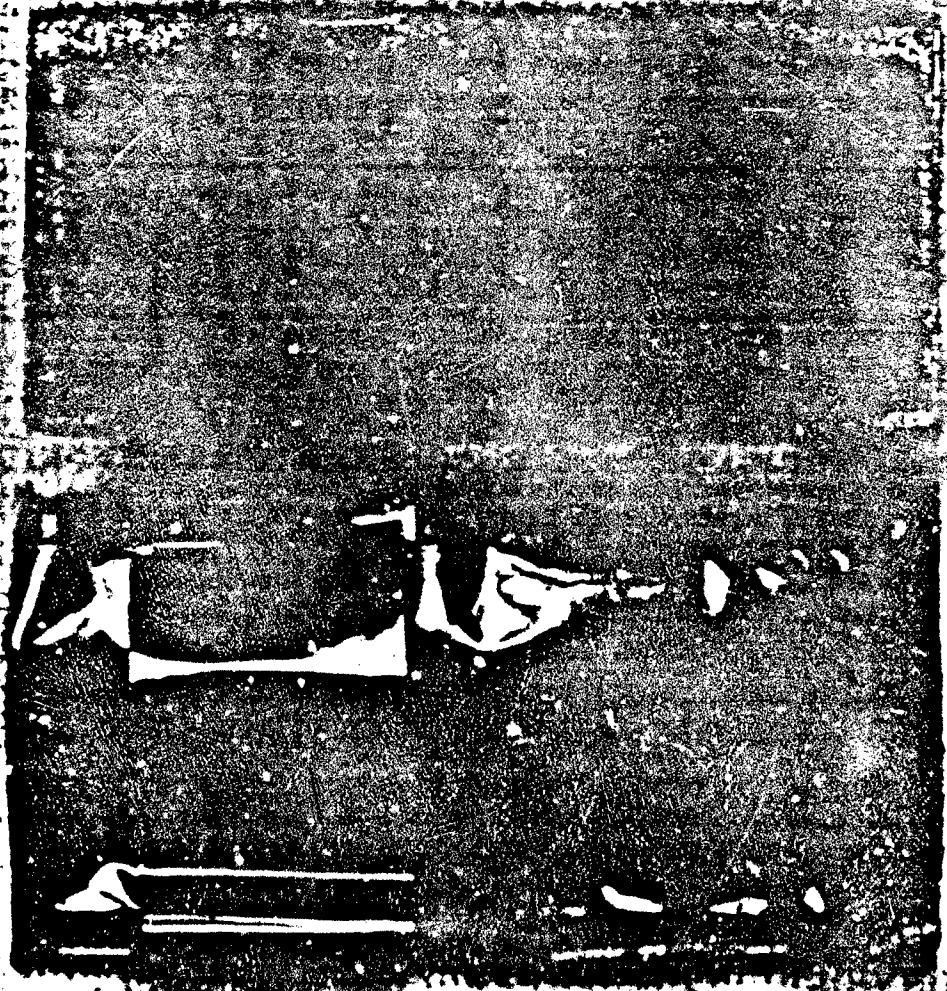

center heat-seal

1 1/2" wide handle

APPLICATOR PAD

Figure 20

DECONTAMINATING KIT, SKIN: M291

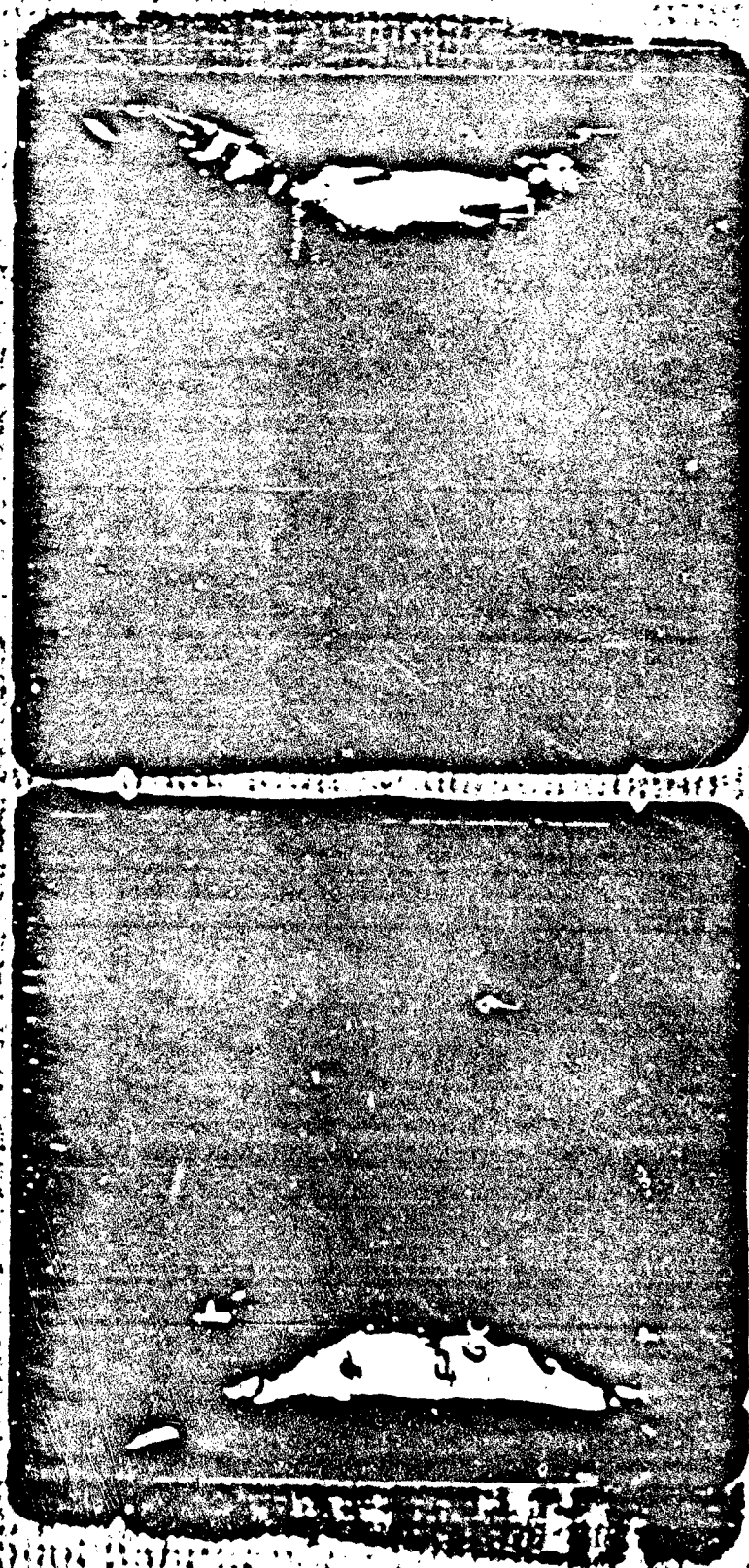

SKIN DECON PACKET

Figure 21

DECONTAMINATING KIT SKIN: M291

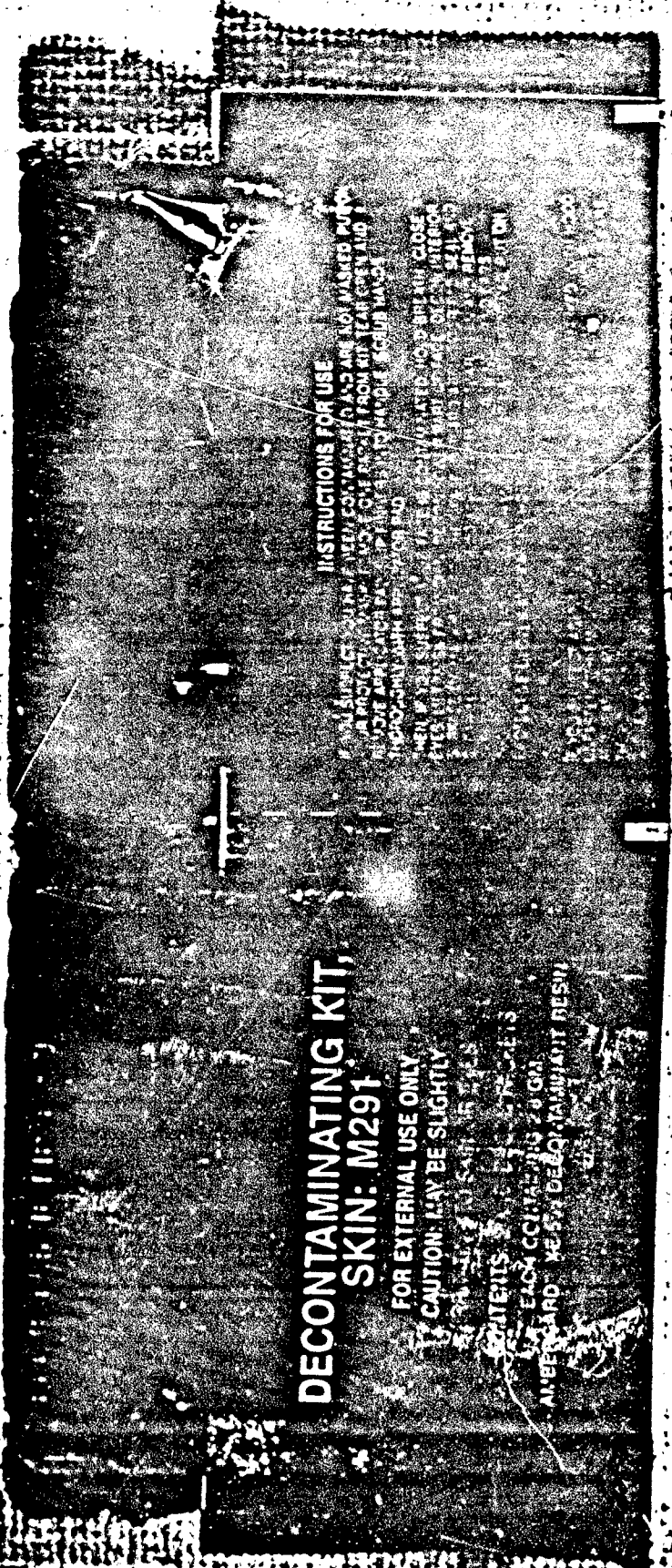

**DECONTAMINATING KIT,
SKIN: M291**

FOR EXTERNAL USE ONLY
CAUTION: MAY BE SLIGHTLY

CONTAINS 1.5 LITERS OF RESIN
EACH CONTAINING 20 GM
AMBERARD YE-57 DECONTAMINATING RESIN

INSTRUCTIONS FOR USE

1. REMOVE CONTAINER FROM PACKAGING AND REMOVE ALL EXCESSIVE RESIN FROM SURFACE.
2. REMOVE CONTAINER FROM PACKAGING AND REMOVE ALL EXCESSIVE RESIN FROM SURFACE.
3. REMOVE CONTAINER FROM PACKAGING AND REMOVE ALL EXCESSIVE RESIN FROM SURFACE.
4. REMOVE CONTAINER FROM PACKAGING AND REMOVE ALL EXCESSIVE RESIN FROM SURFACE.
5. REMOVE CONTAINER FROM PACKAGING AND REMOVE ALL EXCESSIVE RESIN FROM SURFACE.

Figure 22

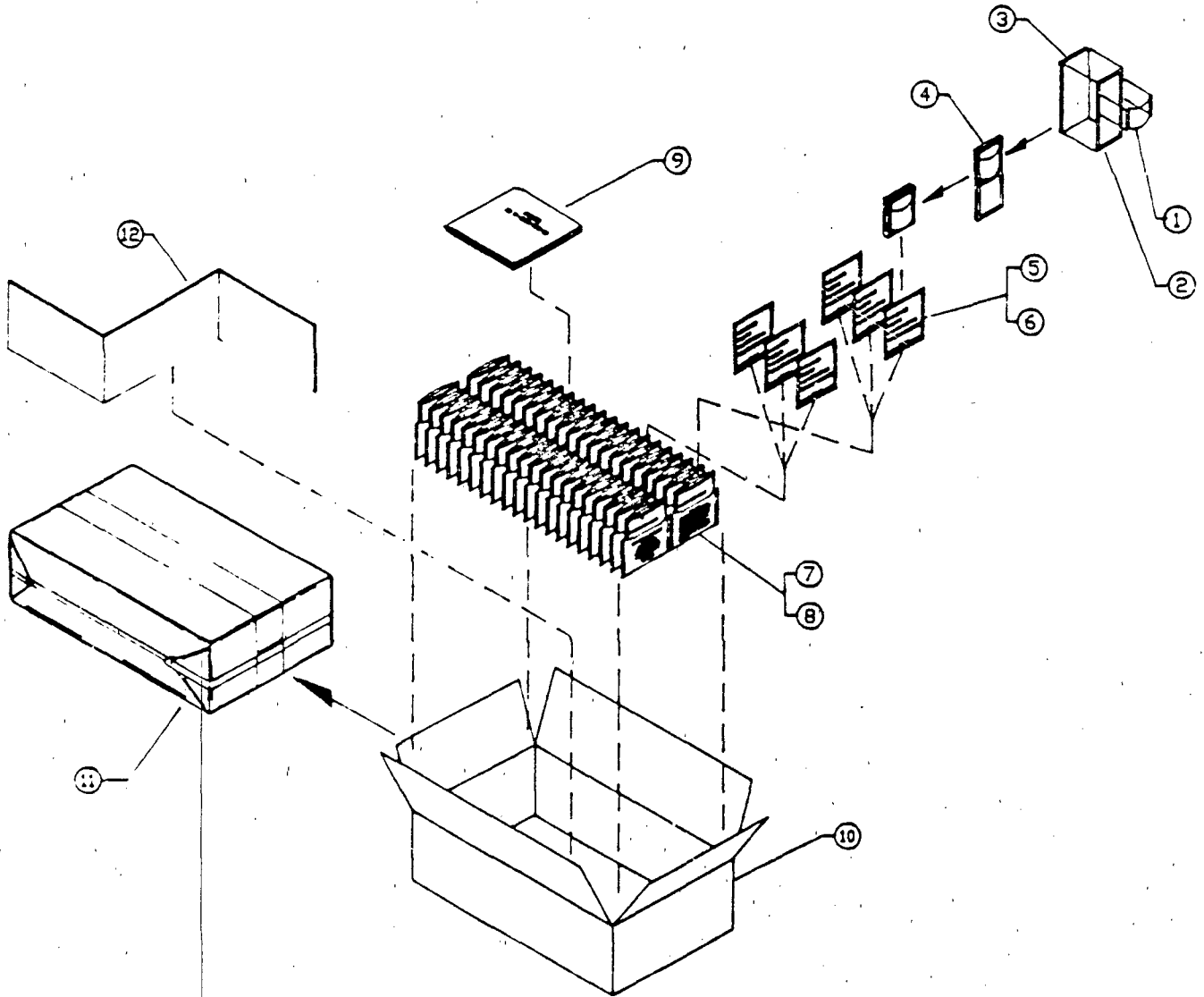

FIGURE 23

R. ENVIRONMENTAL ASSESSMENT (EA)

1. Summary

An Environmental Assessment was prepared by a Rohm and Haas Company Regulatory Specialist. The EA states that no significant environmental impacts are anticipated as a result of the production, deployment, use, or disposal of the M291 SDK. Consistent with its polymeric and carbonaceous nature, the active decontaminating ingredient, Ambergard XE-555 resin, is an essentially safe, environmentally non-hazardous material. All materials may be safely disposed of to conventional sanitary sewers or approved landfills and incinerators. There are no known conflicts or inconsistencies of this program with existing or proposed federal, state, and local land and water use plans, policies, laws, and controls.

APPENDIX A

AMBERGARD XE-555 RESIN STABILITY DATA

AMBERGARD XE-555 STABILITY DATA
PERCENT SOLIDS STORAGE DATA

| OBS | TEMP | MONIH1 | MONIH2 | MONIH3 | MONIH4 | MONIH5 | MONIH6 | MONIH9 | MONIH12 | MONIH8 | MONIH24 | MONIH36 |
|-----|------|--------|--------|--------|--------|--------|--------|--------|---------|--------|---------|---------|
| 1 | 0C | 72.3 | 73.8 | 75.0 | . | 71.8 | 76.1 | 75.5 | 72.9 | 74.1 | 74.2 | |
| 2 | 0C | 72.3 | 73.5 | 75.2 | . | 72.0 | 76.3 | 74.8 | 72.6 | 75.0 | 74.3 | |
| 3 | 25C | 72.3 | 74.2 | 73.9 | . | 72.4 | 76.8 | 74.3 | 72.1 | 72.2 | 72.1 | |
| 4 | 25C | 72.3 | 74.1 | 74.3 | . | 72.7 | 76.7 | 74.3 | 72.0 | 72.2 | 72.2 | |
| 5 | 40C | 72.3 | 73.2 | 73.6 | . | 72.0 | 74.2 | 73.9 | 70.9 | 74.3 | 71.8 | |
| 6 | 40C | 72.3 | 72.6 | 73.8 | . | 72.4 | 73.9 | 73.4 | 71.7 | 74.1 | 71.7 | |
| 7 | 60C | 72.3 | 78.3 | 79.1 | 71.2 | 77.2 | 88.4 | 83.0 | 93.1 | 95.4 | 97.6 | |
| 8 | 60C | 72.3 | 77.8 | 79.1 | 71.2 | 76.2 | 88.8 | 82.5 | 92.0 | 95.2 | 97.6 | |

| VARIABLE | N | MEAN | STANDARD DEVIATION | MINIMUM VALUE | MAXIMUM VALUE | SID ERROR OF MEAN | SUM | VARIANCE | C.V |
|----------|---|------|--------------------|---------------|---------------|-------------------|-----|----------|-----|
|----------|---|------|--------------------|---------------|---------------|-------------------|-----|----------|-----|

TEMP=0C

| | | | | | | | | | |
|---------|---|--------|-------|--------|--------|-------|---------|-------|------|
| MONIH0 | 2 | 72.300 | 0.000 | 72.300 | 72.300 | 0.000 | 144.600 | 0.000 | 0.00 |
| MONIH1 | 2 | 73.650 | 0.212 | 73.500 | 73.800 | 0.150 | 147.300 | 0.045 | 0.28 |
| MONIH2 | 0 | | | | | | | | |
| MONIH3 | 2 | 75.100 | 0.141 | 75.000 | 75.200 | 0.100 | 150.200 | 0.020 | 0.18 |
| MONIH4 | 0 | | | | | | | | |
| MONIH5 | 2 | 71.900 | 0.141 | 71.800 | 72.000 | 0.100 | 143.800 | 0.020 | 0.19 |
| MONIH6 | 2 | 76.200 | 0.141 | 76.100 | 76.300 | 0.100 | 152.400 | 0.020 | 0.18 |
| MONIH7 | 2 | 75.150 | 0.495 | 74.800 | 75.500 | 0.350 | 150.300 | 0.245 | 0.65 |
| MONIH8 | 2 | 72.750 | 0.212 | 72.600 | 72.900 | 0.150 | 145.500 | 0.045 | 0.29 |
| MONIH24 | 2 | 74.550 | 0.636 | 74.100 | 75.000 | 0.450 | 149.100 | 0.405 | 0.85 |
| MONIH36 | 2 | 74.250 | 0.071 | 74.200 | 74.300 | 0.050 | 148.500 | 0.005 | 0.09 |

TEMP=25C

| | | | | | | | | | |
|---------|---|--------|-------|--------|--------|-------|---------|-------|------|
| MONIH9 | 2 | 72.300 | 0.000 | 72.300 | 72.300 | 0.000 | 144.600 | 0.000 | 0.00 |
| MONIH1 | 2 | 74.150 | 0.071 | 74.100 | 74.200 | 0.050 | 148.300 | 0.005 | 0.09 |
| MONIH2 | 2 | 74.100 | 0.141 | 74.000 | 74.200 | 0.100 | 148.200 | 0.020 | 0.19 |
| MONIH3 | 2 | 74.100 | 0.283 | 73.900 | 74.300 | 0.200 | 148.200 | 0.080 | 0.38 |
| MONIH4 | 0 | | | | | | | | |
| MONIH5 | 2 | 72.550 | 0.212 | 72.400 | 72.700 | 0.150 | 145.100 | 0.045 | 0.29 |
| MONIH9 | 2 | 76.750 | 0.071 | 76.700 | 76.800 | 0.050 | 153.500 | 0.005 | 0.09 |
| MONIH12 | 2 | 74.300 | 0.000 | 74.300 | 74.300 | 0.000 | 148.600 | 0.000 | 0.00 |
| MONIH8 | 2 | 72.050 | 0.071 | 72.000 | 72.100 | 0.050 | 144.100 | 0.005 | 0.09 |
| MONIH24 | 2 | 72.200 | 0.000 | 72.200 | 72.200 | 0.000 | 144.400 | 0.000 | 0.00 |
| MONIH36 | 2 | 72.150 | 0.071 | 72.100 | 72.200 | 0.050 | 144.300 | 0.005 | 0.09 |

AMBERGARD XE-555 STABILITY DATA
PERCENT SOLIDS STORAGE DATA

| VARIABLE | N | MEAN | STANDARD DEVIATION | MINIMUM VALUE | MAXIMUM VALUE | SID ERROR OF MEAN | SUM | VARIANCE | C.V |
|----------|---|--------|--------------------|---------------|---------------|-------------------|---------|----------|------|
| TEMP=40C | | | | | | | | | |
| MONIH0 | 2 | 72.300 | 0.000 | 72.300 | 72.300 | 0.000 | 144.600 | 0.000 | 0.00 |
| MONIH1 | 2 | 72.900 | 0.424 | 72.600 | 73.200 | 0.300 | 145.800 | 0.180 | 0.58 |
| MONIH2 | 2 | 76.300 | 0.000 | 76.300 | 76.300 | 0.000 | 152.600 | 0.000 | 0.00 |
| MONIH3 | 2 | 73.700 | 0.141 | 73.600 | 73.800 | 0.100 | 147.400 | 0.020 | 0.19 |
| MONIH4 | 0 | | | | | | | | |
| MONIH5 | 2 | 72.200 | 0.283 | 72.000 | 72.400 | 0.200 | 144.400 | 0.080 | 0.39 |
| MONIH9 | 2 | 74.050 | 0.212 | 73.900 | 74.200 | 0.150 | 148.100 | 0.045 | 0.38 |
| MONIH12 | 2 | 73.650 | 0.354 | 73.400 | 73.900 | 0.250 | 147.300 | 0.125 | 0.48 |
| MONIH18 | 2 | 71.300 | 0.566 | 70.900 | 71.700 | 0.400 | 142.600 | 0.320 | 0.79 |
| MONIH24 | 2 | 74.200 | 0.141 | 74.100 | 74.300 | 0.100 | 148.400 | 0.020 | 0.19 |
| MONIH36 | 2 | 71.750 | 0.071 | 71.700 | 71.800 | 0.050 | 143.500 | 0.005 | 0.09 |
| TEMP=60C | | | | | | | | | |
| MONIH0 | 2 | 72.300 | 0.000 | 72.300 | 72.300 | 0.000 | 144.600 | 0.000 | 0.00 |
| MONIH1 | 2 | 78.050 | 0.354 | 77.800 | 78.300 | 0.250 | 156.100 | 0.125 | 0.45 |
| MONIH2 | 2 | 79.100 | 0.283 | 78.900 | 79.300 | 0.200 | 158.200 | 0.080 | 0.35 |
| MONIH3 | 2 | 79.100 | 0.000 | 79.100 | 79.100 | 0.000 | 158.200 | 0.000 | 0.00 |
| MONIH4 | 2 | 71.200 | 0.000 | 71.200 | 71.200 | 0.000 | 142.400 | 0.000 | 0.00 |
| MONIH5 | 2 | 76.700 | 0.707 | 76.200 | 77.200 | 0.500 | 153.400 | 0.500 | 0.92 |
| MONIH9 | 2 | 88.600 | 0.283 | 88.400 | 88.800 | 0.200 | 177.200 | 0.080 | 0.31 |
| MONIH12 | 2 | 82.750 | 0.354 | 82.500 | 83.000 | 0.250 | 165.500 | 0.125 | 0.42 |
| MONIH18 | 2 | 92.550 | 0.778 | 92.000 | 93.100 | 0.550 | 185.100 | 0.605 | 0.84 |
| MONIH24 | 2 | 95.300 | 0.141 | 95.200 | 95.400 | 0.100 | 190.600 | 0.020 | 0.14 |
| MONIH36 | 2 | 97.600 | 0.000 | 97.600 | 97.600 | 0.000 | 195.200 | 0.000 | 0.00 |

AMERCARD XE-555 STABILITY DATA
SURFACE AREA
(SQ M/G)

| OBS | TEMP | MONIHD | MONIHD | MONIHD | MONIHD |
|-----|------|--------|--------|--------|--------|
| 1 | OC | 407 | 446 | 405 | 405 |
| 2 | OC | . | 444 | 421 | 421 |
| 3 | 25C | 407 | 448 | 420 | 420 |
| 4 | 25C | . | 426 | 421 | 421 |
| 5 | 40C | 407 | 449 | 392 | 392 |
| 6 | 40C | . | 449 | 414 | 414 |
| 7 | 60C | 407 | 397 | 375 | 375 |
| 8 | 60C | . | 396 | 379 | 379 |

| VARIABLE | N | MEAN | STANDARD DEVIATION | MINIMUM VALUE | MAXIMUM VALUE | SID ERROR OF MEAN | SUM | VARIANCE | C.V |
|----------|---|------|--------------------|---------------|---------------|-------------------|-----|----------|-----|
|----------|---|------|--------------------|---------------|---------------|-------------------|-----|----------|-----|

TEMP=OC

| | | | | | | | | | |
|--------|---|---------|--------|---------|---------|-------|---------|---------|------|
| MONIHD | 1 | 407.000 | . | 407.000 | 407.000 | . | 407.000 | . | . |
| MONIHD | 2 | 445.000 | 1.414 | 444.000 | 446.000 | 1.000 | 890.000 | 2.000 | 0.31 |
| MONIHD | 2 | 413.000 | 11.314 | 405.000 | 421.000 | 8.000 | 826.000 | 128.000 | 2.73 |

TEMP=25C

| | | | | | | | | | |
|--------|---|---------|--------|---------|---------|--------|---------|---------|------|
| MONIHD | 1 | 407.000 | . | 407.000 | 407.000 | . | 407.000 | . | . |
| MONIHD | 2 | 437.000 | 15.556 | 426.000 | 448.000 | 11.000 | 874.000 | 242.000 | 3.56 |
| MONIHD | 2 | 420.500 | 0.707 | 420.000 | 421.000 | 0.500 | 841.000 | 0.500 | 0.16 |

TEMP=40C

| | | | | | | | | | |
|--------|---|---------|--------|---------|---------|--------|---------|---------|------|
| MONIHD | 1 | 407.000 | . | 407.000 | 407.000 | . | 407.000 | . | . |
| MONIHD | 2 | 449.000 | 0.000 | 449.000 | 449.000 | 0.000 | 898.000 | 0.000 | 0.00 |
| MONIHD | 2 | 403.000 | 15.556 | 392.000 | 414.000 | 11.000 | 806.000 | 242.000 | 3.86 |

TEMP=60C

| | | | | | | | | | |
|--------|---|---------|-------|---------|---------|-------|---------|-------|------|
| MONIHD | 1 | 407.000 | . | 407.000 | 407.000 | . | 407.000 | . | . |
| MONIHD | 2 | 396.500 | 0.707 | 396.000 | 397.000 | 0.500 | 793.000 | 0.500 | 0.17 |
| MONIHD | 2 | 377.000 | 2.828 | 375.000 | 379.000 | 2.000 | 754.000 | 8.000 | 0.75 |

PARTICLE SIZE STORAGE DATA
(MICRONS)

| OBS | TEMP | MONIH0 | MONIH1 | MONIH2 | MONIH3 | MONIH4 | MONIH6 | MONIH9 | MONIH12 | MONIH24 | C.V |
|-----|------|--------|--------|--------|--------|--------|--------|--------|---------|---------|-----|
| 1 | 0C | 5.5 | 8.4 | . | 3.8 | . | 4.1 | 7.5 | 7.9 | 6.8 | |
| 2 | 0C | 6.3 | . | . | 3.9 | . | 4.0 | 7.4 | 8.4 | 6.7 | |
| 3 | 0C | . | . | . | 4.0 | . | 3.5 | 7.7 | 8.3 | 6.6 | |
| 4 | 0C | . | . | . | 3.9 | . | 3.5 | 7.3 | 8.1 | 6.5 | |
| 5 | 25C | 5.5 | 6.5 | 6.3 | 4.8 | . | 4.3 | 7.7 | 6.3 | 6.5 | |
| 6 | 25C | 6.3 | . | 6.2 | 4.9 | . | 4.0 | 7.5 | 6.0 | 6.8 | |
| 7 | 25C | . | . | 6.0 | 5.0 | . | 4.2 | 9.1 | 5.8 | 6.6 | |
| 8 | 25C | . | . | 6.1 | 5.0 | . | 4.0 | 8.0 | 5.4 | 6.3 | |
| 9 | 40C | 5.5 | 6.7 | 4.3 | 4.4 | . | 4.2 | 9.3 | 6.6 | 7.1 | |
| 10 | 40C | 6.3 | . | 4.2 | 4.3 | . | 4.4 | 8.7 | 6.3 | 6.9 | |
| 11 | 40C | . | . | 4.3 | 4.3 | . | 4.1 | 8.9 | 7.4 | 6.9 | |
| 12 | 40C | . | . | 4.2 | 4.0 | . | 4.3 | 11.5 | 7.0 | 6.8 | |
| 13 | 60C | 5.3 | 9.6 | 17.2 | 7.7 | 4.5 | 6.7 | 7.9 | . | 10.9 | |
| 14 | 60C | 6.3 | . | 16.5 | 8.0 | 4.4 | 6.5 | . | . | 11.8 | |
| 15 | 60C | . | . | 16.4 | 6.8 | 4.4 | 7.2 | 7.3 | . | 13.6 | |
| 16 | 60C | . | . | 16.5 | 7.4 | 4.3 | 7.0 | 7.1 | . | 14.0 | |

A-4

TEMP=0C

| VARIABLE | N | MEAN | STANDARD DEVIATION | MINIMUM VALUE | MAXIMUM VALUE | STD ERROR OF MEAN | SUM | VARIANCE | C.V |
|----------|---|-------|--------------------|---------------|---------------|-------------------|--------|----------|------|
| MONIH0 | 2 | 5.900 | 0.566 | 5.500 | 6.300 | 0.400 | 11.800 | 0.320 | 9.58 |
| MONIH1 | 1 | 8.400 | . | 8.400 | 8.400 | . | 8.400 | . | . |
| MONIH2 | 0 | . | . | . | . | . | . | . | . |
| MONIH3 | 4 | 3.900 | 0.082 | 3.800 | 4.000 | 0.041 | 15.600 | 0.007 | 2.09 |
| MONIH4 | 0 | . | . | . | . | . | . | . | . |
| MONIH6 | 4 | 3.775 | 0.320 | 3.500 | 4.100 | 0.160 | 15.100 | 0.102 | 8.48 |
| MONIH9 | 4 | 7.475 | 0.171 | 7.300 | 7.700 | 0.085 | 29.900 | 0.029 | 2.28 |
| MONIH12 | 4 | 8.175 | 0.222 | 7.900 | 8.400 | 0.111 | 32.700 | 0.049 | 2.71 |
| MONIH24 | 4 | 6.650 | 0.129 | 6.500 | 6.800 | 0.065 | 26.600 | 0.017 | 1.94 |

PARTICLE SIZE STORAGE DATA
(MICRONS)

| VARIABLE | N | MEAN | STANDARD DEVIATION | MINIMUM VALUE | MAXIMUM VALUE | STD ERROR OF MEAN | SUM | VARIANCE | C.V |
|----------|---|--------|--------------------|---------------|---------------|-------------------|--------|----------|-------|
| TEMP=25C | | | | | | | | | |
| MONIH0 | 2 | 5.900 | 0.566 | 5.500 | 6.300 | 0.400 | 11.800 | 0.320 | 9.58 |
| MONIH1 | 1 | 6.500 | | 6.500 | 6.500 | | 6.500 | | |
| MONIH2 | 4 | 6.150 | 0.129 | 6.000 | 6.300 | 0.065 | 24.600 | 0.017 | 2.09 |
| MONIH3 | 4 | 4.925 | 0.096 | 4.800 | 5.000 | 0.048 | 19.700 | 0.009 | 1.94 |
| MONIH4 | 0 | | | | | | | | |
| MONIH6 | 4 | 4.125 | 0.150 | 4.000 | 4.300 | 0.075 | 16.500 | 0.022 | 3.63 |
| MONIH9 | 4 | 8.075 | 0.714 | 7.500 | 9.100 | 0.357 | 32.300 | 0.509 | 8.83 |
| MONIH12 | 4 | 5.875 | 0.377 | 5.400 | 6.000 | 0.189 | 23.500 | 0.142 | 6.42 |
| MONIH24 | 4 | 6.550 | 0.208 | 6.300 | 6.800 | 0.104 | 26.200 | 0.043 | 3.17 |
| TEMP=40C | | | | | | | | | |
| MONIH0 | 2 | 5.900 | 0.566 | 5.500 | 6.300 | 0.400 | 11.800 | 0.320 | 9.58 |
| MONIH1 | | 6.700 | | 6.700 | 6.700 | | 6.700 | | |
| MONIH2 | 4 | 4.250 | 0.058 | 4.200 | 4.300 | 0.029 | 17.000 | 0.003 | 1.35 |
| MONIH3 | 4 | 4.250 | 0.173 | 4.000 | 4.400 | 0.087 | 17.000 | 0.030 | 4.07 |
| MONIH4 | 0 | | | | | | | | |
| MONIH6 | 4 | 4.250 | 0.129 | 4.100 | 4.400 | 0.065 | 17.000 | 0.017 | 3.03 |
| MONIH9 | 4 | 9.600 | 1.291 | 8.700 | 11.500 | 0.645 | 38.400 | 1.667 | 13.44 |
| MONIH12 | 4 | 6.825 | 0.479 | 6.300 | 7.400 | 0.239 | 27.300 | 0.229 | 7.01 |
| MONIH24 | 4 | 6.925 | 0.126 | 6.800 | 7.100 | 0.063 | 27.700 | 0.016 | 1.81 |
| TEMP=60C | | | | | | | | | |
| MONIH0 | 2 | 5.800 | 0.707 | 5.300 | 6.300 | 0.500 | 11.600 | 0.500 | 12.19 |
| MONIH1 | 1 | 9.600 | | 9.600 | 9.600 | | 9.600 | | |
| MONIH2 | 4 | 16.650 | 0.370 | 16.400 | 17.200 | 0.185 | 66.600 | 0.137 | 2.22 |
| MONIH3 | 4 | 7.475 | 0.512 | 6.800 | 8.000 | 0.256 | 29.900 | 0.262 | 6.85 |
| MONIH4 | 4 | 4.400 | 0.082 | 4.300 | 4.500 | 0.041 | 17.600 | 0.007 | 1.85 |
| MONIH6 | 4 | 6.850 | 0.311 | 6.500 | 7.200 | 0.155 | 27.400 | 0.097 | 4.53 |
| MONIH9 | 3 | 7.433 | 0.416 | 7.100 | 7.900 | 0.240 | 22.300 | 0.173 | 5.60 |
| MONIH12 | 0 | | | | | | | | |
| MONIH24 | 4 | 12.575 | 1.471 | 10.900 | 14.000 | 0.735 | 50.300 | 2.163 | 11.69 |

AMBERCARD XE-555 STABILITY DATA
PERCENT EXTRACTABLES STORAGE DATA

| OBS | TEMP | MCNIH0 | MCNIH1 | MCNIH2 | MCNIH3 | MCNIH4 | MCNIH6 | MCNIH9 | MCNIH12 | MCNIH18 | MCNIH24 | MCNIH36 |
|-----|------|--------|--------|--------|--------|--------|--------|--------|---------|---------|---------|---------|
| 1 | 0C | 0.024 | 0.024 | . | 0.008 | . | 0.024 | 0.017 | 0.058 | 0.000 | 0.057 | 0.07 |
| 2 | 0C | 0.025 | 0.016 | . | 0.025 | . | 0.017 | 0.016 | 0.066 | 0.000 | 0.048 | 0.04 |
| 3 | 25C | 0.024 | 0.033 | 0.049 | 0.025 | . | 0.016 | 0.008 | 0.059 | 0.040 | 0.016 | 0.08 |
| 4 | 25C | 0.025 | 0.034 | 0.034 | 0.024 | . | 0.031 | 0.016 | 0.051 | . | 0.033 | 0.03 |
| 5 | 40C | 0.024 | 0.034 | 0.042 | 0.041 | . | 0.016 | 0.032 | 0.050 | 0.021 | 0.050 | 0.08 |
| 6 | 40C | 0.025 | 0.040 | 0.033 | 0.008 | . | 0.033 | 0.025 | 0.033 | . | 0.040 | 0.03 |
| 7 | 60C | 0.024 | 0.067 | 0.074 | 0.073 | 0.038 | 0.059 | 0.057 | 0.084 | 0.090 | 0.107 | 0.17 |
| 8 | 60C | 0.025 | 0.066 | 0.068 | 0.074 | 0.056 | 0.067 | 0.056 | 0.102 | . | 0.116 | 0.13 |

| VARIABLE | N | MEAN | STANDARD DEVIATION | MINIMUM VALUE | MAXIMUM VALUE | STD ERROR OF MEAN | SUM | VARIANCE | C.V |
|----------|---|------|--------------------|---------------|---------------|-------------------|-----|----------|-----|
|----------|---|------|--------------------|---------------|---------------|-------------------|-----|----------|-----|

TEMP=0C

| | | | | | | | | | |
|---------|---|-------|-------|-------|-------|-------|-------|-------|-------|
| MCNIH0 | 2 | 0.024 | 0.001 | 0.024 | 0.025 | 0.001 | 0.049 | 0.000 | 2.88 |
| MCNIH1 | 2 | 0.020 | 0.006 | 0.016 | 0.024 | 0.004 | 0.040 | 0.000 | 28.28 |
| MCNIH2 | 0 | . | . | . | . | . | . | . | . |
| MCNIH3 | 2 | 0.016 | 0.012 | 0.008 | 0.025 | 0.009 | 0.033 | 0.000 | 72.85 |
| MCNIH4 | 0 | . | . | . | . | . | . | . | . |
| MCNIH6 | 2 | 0.020 | 0.005 | 0.017 | 0.024 | 0.003 | 0.041 | 0.000 | 24.14 |
| MCNIH9 | 2 | 0.016 | 0.001 | 0.016 | 0.017 | 0.000 | 0.033 | 0.000 | 4.28 |
| MCNIH12 | 2 | 0.062 | 0.006 | 0.058 | 0.066 | 0.004 | 0.124 | 0.000 | 9.12 |
| MCNIH18 | 2 | 0.000 | 0.000 | 0.000 | 0.000 | 0.000 | 0.000 | 0.000 | . |
| MCNIH24 | 2 | 0.052 | 0.006 | 0.048 | 0.057 | 0.004 | 0.105 | 0.000 | 12.12 |
| MCNIH36 | 2 | 0.055 | 0.021 | 0.040 | 0.070 | 0.015 | 0.110 | 0.000 | 38.56 |

TEMP=25C

| | | | | | | | | | |
|---------|---|-------|-------|-------|-------|-------|-------|-------|-------|
| MCNIH0 | 2 | 0.024 | 0.001 | 0.024 | 0.025 | 0.001 | 0.049 | 0.000 | 2.88 |
| MCNIH1 | 2 | 0.033 | 0.001 | 0.033 | 0.034 | 0.001 | 0.067 | 0.000 | 2.11 |
| MCNIH2 | 2 | 0.041 | 0.011 | 0.034 | 0.049 | 0.007 | 0.083 | 0.000 | 25.55 |
| MCNIH3 | 2 | 0.024 | 0.001 | 0.024 | 0.025 | 0.000 | 0.045 | 0.000 | 2.88 |
| MCNIH4 | 0 | . | . | . | . | . | . | . | . |
| MCNIH6 | 2 | 0.023 | 0.011 | 0.016 | 0.031 | 0.008 | 0.047 | 0.000 | 45.13 |
| MCNIH9 | 2 | 0.012 | 0.006 | 0.008 | 0.016 | 0.004 | 0.024 | 0.000 | 47.14 |
| MCNIH12 | 2 | 0.055 | 0.006 | 0.051 | 0.059 | 0.004 | 0.110 | 0.000 | 10.28 |
| MCNIH18 | 1 | 0.040 | . | 0.040 | 0.040 | . | 0.040 | . | . |
| MCNIH24 | 2 | 0.024 | 0.012 | 0.016 | 0.033 | 0.009 | 0.049 | 0.000 | 49.06 |
| MCNIH36 | 2 | 0.055 | 0.035 | 0.030 | 0.080 | 0.025 | 0.110 | 0.001 | 64.28 |

AMEERGO XE-555 STABILITY DATA
PERCENT EXTRACTABLES STORAGE DATA

A-7

| VARIABLE | N | MEAN | STANDARD DEVIATION | MINIMUM VALUE | MAXIMUM VALUE | STD ERROR OF MEAN | SUM | VARIANCE | C.V |
|----------|---|-------|--------------------|---------------|---------------|-------------------|-------|----------|-------|
| TEMP=40C | | | | | | | | | |
| MONIH0 | 2 | 0.024 | 0.001 | 0.024 | 0.025 | 0.001 | 0.049 | 0.000 | 2.88 |
| MONIH1 | 2 | 0.037 | 0.004 | 0.034 | 0.040 | 0.003 | 0.074 | 0.000 | 11.46 |
| MONIH2 | 2 | 0.037 | 0.006 | 0.033 | 0.042 | 0.004 | 0.075 | 0.000 | 16.97 |
| MONIH3 | 2 | 0.024 | 0.023 | 0.038 | 0.041 | 0.016 | 0.049 | 0.001 | 95.24 |
| MONIH4 | 0 | | | | | | | | |
| MONIH6 | 2 | 0.024 | 0.012 | 0.016 | 0.033 | 0.009 | 0.049 | 0.000 | 49.06 |
| MONIH9 | 2 | 0.028 | 0.005 | 0.025 | 0.032 | 0.003 | 0.057 | 0.000 | 17.36 |
| MONIH12 | 2 | 0.041 | 0.012 | 0.033 | 0.050 | 0.008 | 0.083 | 0.000 | 28.96 |
| MONIH18 | 1 | 0.021 | | 0.021 | 0.021 | | 0.021 | | |
| MONIH24 | 2 | 0.045 | 0.007 | 0.040 | 0.050 | 0.005 | 0.090 | 0.000 | 15.71 |
| MONIH6 | 2 | 0.055 | 0.035 | 0.030 | 0.080 | 0.025 | 0.110 | 0.001 | 64.28 |

| VARIABLE | N | MEAN | STANDARD DEVIATION | MINIMUM VALUE | MAXIMUM VALUE | STD ERROR OF MEAN | SUM | VARIANCE | C.V |
|----------|---|-------|--------------------|---------------|---------------|-------------------|-------|----------|-------|
| TEMP=60C | | | | | | | | | |
| MONIH0 | 2 | 0.024 | 0.001 | 0.024 | 0.025 | 0.001 | 0.049 | 0.000 | 2.88 |
| MONIH1 | 2 | 0.066 | 0.001 | 0.066 | 0.067 | 0.001 | 0.133 | 0.000 | 1.06 |
| MONIH2 | 2 | 0.071 | 0.004 | 0.068 | 0.074 | 0.003 | 0.142 | 0.000 | 5.97 |
| MONIH3 | 2 | 0.073 | 0.001 | 0.073 | 0.074 | 0.001 | 0.147 | 0.000 | 0.96 |
| MONIH4 | 2 | 0.047 | 0.013 | 0.038 | 0.056 | 0.009 | 0.094 | 0.000 | 27.08 |
| MONIH6 | 2 | 0.063 | 0.006 | 0.059 | 0.067 | 0.004 | 0.126 | 0.000 | 8.97 |
| MONIH9 | 2 | 0.056 | 0.001 | 0.056 | 0.057 | 0.000 | 0.113 | 0.000 | 1.25 |
| MONIH12 | 2 | 0.093 | 0.013 | 0.084 | 0.102 | 0.009 | 0.186 | 0.000 | 13.68 |
| MONIH18 | 1 | 0.090 | | 0.090 | 0.090 | | 0.090 | | |
| MONIH24 | 2 | 0.111 | 0.006 | 0.107 | 0.116 | 0.005 | 0.223 | 0.000 | 5.70 |
| MONIH6 | 2 | 0.150 | 0.028 | 0.130 | 0.170 | 0.020 | 0.300 | 0.001 | 18.85 |

AMBERCARD XE-555 STABILITY DATA
CIS VAPOR DESORPTION (% DESORBED)

| OBS | TEMP | MONIH0 | MONIH1 | MONIH2 | MONIH3 | MONIH4 | MONIH5 | MONIH6 | MONIH9 | MONIH12 | MONIH8 | MONIH24 | MONIH36 |
|-----|------|--------|--------|--------|--------|--------|--------|--------|--------|---------|--------|---------|---------|
| 1 | 0C | 4.4 | 11.2 | . | 9.0 | . | 11.9 | 13.4 | 9.3 | 9.1 | 8.4 | 2.0 | |
| 2 | 0C | 7.5 | 8.4 | . | 16.1 | . | 5.6 | 4.2 | 10.3 | 9.4 | 15.0 | 3.5 | |
| 3 | 25C | 4.4 | 10.6 | 4.5 | 12.1 | . | 10.5 | 4.0 | 8.2 | 7.3 | 6.4 | 5.0 | |
| 4 | 25C | 7.5 | 7.1 | 8.3 | 9.7 | . | 7.5 | 4.3 | 6.3 | 6.5 | 7.0 | 2.4 | |
| 5 | 40C | 4.4 | 7.0 | 6.8 | 9.5 | . | 10.9 | 10.4 | 9.3 | 8.3 | 6.5 | 3.0 | |
| 6 | 40C | 7.5 | 4.5 | 6.1 | 9.0 | . | 11.4 | 7.6 | 10.5 | 6.1 | 9.1 | 2.4 | |
| 7 | 60C | 4.4 | 7.3 | 9.0 | 7.1 | 12.5 | 7.2 | 4.5 | 6.7 | 10.5 | 8.7 | 1.2 | |
| 8 | 60C | 7.5 | 7.8 | 4.5 | 9.0 | 10.8 | 7.5 | 7.9 | 5.0 | 9.0 | 4.3 | 2.4 | |

| VARIABLE | N | MEAN | STANDARD DEVIATION | MINIMUM VALUE | MAXIMUM VALUE | STD ERROR OF MEAN | SUM | VARIANCE | C.V |
|----------|---|------|--------------------|---------------|---------------|-------------------|-----|----------|-----|
|----------|---|------|--------------------|---------------|---------------|-------------------|-----|----------|-----|

TEMP=0C

| | | | | | | | | | |
|---------|---|--------|-------|-------|--------|-------|--------|--------|-------|
| MONIH0 | 2 | 5.950 | 2.192 | 4.400 | 7.500 | 1.550 | 11.900 | 4.805 | 36.84 |
| MONIH1 | 2 | 9.800 | 1.980 | 8.400 | 11.200 | 1.400 | 19.600 | 3.920 | 20.20 |
| MONIH2 | 0 | | | | | | | | |
| MONIH3 | 2 | 12.550 | 5.020 | 9.000 | 16.100 | 3.550 | 25.100 | 25.205 | 40.00 |
| MONIH4 | 0 | | | | | | | | |
| MONIH5 | 2 | 8.750 | 4.455 | 5.600 | 11.900 | 3.150 | 17.500 | 19.845 | 50.91 |
| MONIH6 | 2 | 8.800 | 6.505 | 4.200 | 13.400 | 4.600 | 17.600 | 42.320 | 73.92 |
| MONIH7 | 2 | 9.800 | 0.707 | 9.300 | 10.300 | 0.500 | 19.600 | 0.500 | 7.21 |
| MONIH8 | 2 | 9.250 | 0.212 | 9.100 | 9.400 | 0.150 | 18.500 | 0.045 | 2.29 |
| MONIH9 | 2 | 11.700 | 4.667 | 8.400 | 15.000 | 3.300 | 23.400 | 21.780 | 39.88 |
| MONIH10 | 2 | 2.750 | 1.061 | 2.000 | 3.500 | 0.750 | 5.500 | 1.125 | 38.56 |

TEMP=25C

| | | | | | | | | | |
|---------|---|--------|-------|-------|--------|-------|--------|-------|-------|
| MONIH0 | 2 | 5.950 | 2.192 | 4.400 | 7.500 | 1.550 | 11.900 | 4.805 | 36.84 |
| MONIH1 | 2 | 8.850 | 2.475 | 7.100 | 10.600 | 1.750 | 17.700 | 6.125 | 27.96 |
| MONIH2 | 2 | 6.400 | 2.687 | 4.500 | 8.300 | 1.900 | 12.300 | 7.220 | 41.98 |
| MONIH3 | 2 | 10.900 | 1.697 | 9.700 | 12.100 | 1.200 | 21.800 | 2.880 | 15.56 |
| MONIH4 | 0 | | | | | | | | |
| MONIH5 | 2 | 9.000 | 2.121 | 7.500 | 10.500 | 1.500 | 18.000 | 4.500 | 23.57 |
| MONIH6 | 2 | 4.150 | 0.212 | 4.000 | 4.300 | 0.150 | 8.300 | 0.045 | 5.11 |
| MONIH7 | 2 | 7.250 | 1.344 | 6.300 | 8.200 | 0.950 | 14.500 | 1.805 | 18.53 |
| MONIH8 | 2 | 6.900 | 0.566 | 6.500 | 7.300 | 0.400 | 13.800 | 0.320 | 8.19 |
| MONIH9 | 2 | 6.700 | 0.424 | 6.400 | 7.000 | 0.300 | 13.400 | 0.180 | 6.33 |
| MONIH10 | 2 | 3.700 | 1.838 | 2.400 | 5.000 | 1.300 | 7.400 | 3.380 | 49.68 |

AMBERGARD XE-555 STABILITY DATA
 CIS VAPOR DESORPTION
 & DESORBED

| VARIABLE | N | MEAN | STANDARD DEVIATION | TEMP=40C | | STD ERROR OF MEAN | SUM | VARIANCE | C.V |
|----------|---|--------|-----------------------|------------------|------------------|----------------------|--------|----------|-------|
| | | | | MINIMUM VALUE | MAXIMUM VALUE | | | | |
| MONIH0 | 2 | 5.950 | 2.192 | 4.400 | 7.500 | 1.550 | 11.900 | 4.805 | 36.84 |
| MONIH1 | 2 | 5.750 | 1.768 | 4.500 | 7.000 | 1.250 | 11.500 | 3.125 | 30.74 |
| MONIH2 | 2 | 6.450 | 0.495 | 6.100 | 6.800 | 0.350 | 12.900 | 0.245 | 7.67 |
| MONIH3 | 2 | 9.250 | 0.354 | 9.000 | 9.500 | 0.250 | 18.500 | 0.125 | 3.82 |
| MONIH4 | 0 | | | | | | | | |
| MONIH6 | 2 | 11.150 | 0.354 | 10.900 | 11.400 | 0.250 | 22.300 | 0.125 | 3.17 |
| MONIH9 | 2 | 9.000 | 1.980 | 7.600 | 10.400 | 1.400 | 18.000 | 3.920 | 21.99 |
| MONIH12 | 2 | 9.900 | 0.849 | 9.300 | 10.500 | 0.600 | 19.800 | 0.720 | 8.57 |
| MONIH18 | 2 | 7.200 | 1.556 | 6.100 | 8.300 | 1.100 | 14.400 | 2.420 | 21.60 |
| MONIH24 | 2 | 7.800 | 1.838 | 6.500 | 9.100 | 1.300 | 15.600 | 3.380 | 23.57 |
| MONIH36 | 2 | 2.700 | 0.424 | 2.400 | 3.000 | 0.300 | 5.400 | 0.180 | 15.71 |

TEMP=60C

| | | | | | | | | | |
|---------|---|--------|-------|--------|--------|-------|--------|--------|-------|
| MONIH0 | 2 | 5.950 | 2.192 | 4.400 | 7.500 | 1.550 | 11.900 | 4.805 | 36.84 |
| MONIH1 | 2 | 7.550 | 0.354 | 7.300 | 7.800 | 0.250 | 15.100 | 0.125 | 4.68 |
| MONIH2 | 2 | 6.750 | 3.182 | 4.500 | 9.000 | 2.250 | 13.500 | 10.125 | 47.14 |
| MONIH3 | 2 | 8.650 | 1.344 | 7.100 | 9.000 | 0.950 | 16.100 | 1.805 | 16.68 |
| MONIH4 | 2 | 11.650 | 1.202 | 10.800 | 12.500 | 0.850 | 23.300 | 1.445 | 10.51 |
| MONIH6 | 2 | 7.350 | 0.212 | 7.200 | 7.500 | 0.150 | 14.700 | 0.045 | 2.88 |
| MONIH9 | 2 | 6.200 | 2.404 | 4.500 | 7.900 | 1.700 | 12.400 | 5.780 | 38.77 |
| MONIH12 | 2 | 5.850 | 1.202 | 5.000 | 6.700 | 0.850 | 11.700 | 1.445 | 20.54 |
| MONIH18 | 2 | 9.750 | 1.061 | 9.000 | 10.500 | 0.750 | 19.500 | 1.125 | 10.87 |
| MONIH24 | 2 | 6.500 | 3.111 | 4.300 | 8.700 | 2.200 | 13.000 | 9.680 | 47.86 |
| MONIH36 | 2 | 1.800 | 0.849 | 1.200 | 2.400 | 0.600 | 3.600 | 0.720 | 47.14 |

AMBERGARD XE-555 STABILITY DATA
DEP VAPOR DESCRIPTION (% DESCRIBED)

| OBS | TEMP | MONIH0 | MONIH1 | MONIH2 | MONIH3 | MONIH4 | MONIH6 | MONIH9 | MONIH12 | MONIH18 | MONIH24 | MONIH36 | TEMP=0C | | | | C.V | | | | |
|-----|------|--------|--------|--------|--------|--------|--------|--------|---------|---------|---------|---------|---------|--------|--------------------|---------------|--------|---------------|-------------------|--------|----------|
| | | | | | | | | | | | | | N | MEAN | STANDARD DEVIATION | MINIMUM VALUE | | MAXIMUM VALUE | STD ERROR OF MEAN | SUM | VARIANCE |
| 1 | 0C | 7.4 | 8.8 | . | 13.7 | . | 10.5 | 8.6 | 10.3 | 16.2 | 7.6 | 3.7 | 2 | 9.000 | 2.263 | 7.400 | 10.600 | 1.600 | 18.000 | 5.120 | 25.14 |
| 2 | 0C | 10.6 | 2.4 | . | . | . | 3.9 | 3.5 | 11.2 | 11.9 | 14.7 | 6.3 | 2 | 5.600 | 4.525 | 2.400 | 8.800 | 3.200 | 11.700 | 20.480 | 80.81 |
| 3 | 25C | 7.4 | 10.6 | 6.7 | 8.1 | . | 8.3 | 6.3 | 6.3 | 10.0 | 6.9 | 1.8 | 0 | | | | | | | | |
| 4 | 25C | 10.6 | 7.1 | 3.3 | . | . | 9.4 | 7.7 | 7.0 | 6.6 | 6.4 | 2.5 | 1 | 13.700 | . | 13.700 | 13.700 | . | 13.700 | . | . |
| 5 | 40C | 7.4 | 13.9 | 7.7 | 6.9 | . | 6.2 | 10.3 | 9.3 | 12.1 | 8.5 | 5.9 | 2 | 7.200 | 4.667 | 3.900 | 10.500 | 3.300 | 14.400 | 21.780 | 64.81 |
| 6 | 40C | 10.6 | 10.1 | 5.0 | . | . | 8.4 | 5.5 | 10.5 | 13.4 | 7.4 | 3.8 | 2 | 6.050 | 3.606 | 3.500 | 8.600 | 2.550 | 12.100 | 13.005 | 59.60 |
| 7 | 60C | 7.4 | 13.3 | 4.1 | 8.4 | 5.3 | 8.7 | 3.9 | 10.4 | 8.2 | 5.8 | 1.3 | 2 | 10.750 | 0.636 | 10.300 | 11.200 | 0.450 | 21.500 | 0.405 | 5.92 |
| 8 | 60C | 10.6 | 8.3 | 5.6 | . | 3.8 | 9.7 | 7.2 | 5.0 | 9.6 | 8.3 | 8.1 | 2 | 14.050 | 3.041 | 11.900 | 16.200 | 2.150 | 28.100 | 9.245 | 21.64 |
| | | | | | | | | | | | | | 2 | 11.150 | 5.020 | 7.600 | 14.700 | 3.550 | 22.300 | 25.205 | 45.02 |
| | | | | | | | | | | | | | 2 | 5.000 | 1.838 | 3.700 | 6.300 | 1.300 | 10.000 | 3.380 | 36.77 |

| TEMP=25C | | | | | | | | | | | | |
|----------|---|-------|--------------------|---------------|---------------|-------------------|--------|----------|-------|--|--|--|
| VARIABLE | N | MEAN | STANDARD DEVIATION | MINIMUM VALUE | MAXIMUM VALUE | STD ERROR OF MEAN | SUM | VARIANCE | C.V | | | |
| MONIH0 | 2 | 9.000 | 2.263 | 7.400 | 10.600 | 1.600 | 18.000 | 5.120 | 25.14 | | | |
| MONIH1 | 2 | 8.850 | 2.475 | 7.100 | 10.600 | 1.750 | 17.700 | 6.125 | 27.96 | | | |
| MONIH2 | 2 | 5.000 | 2.404 | 3.300 | 6.700 | 1.700 | 10.000 | 5.780 | 48.08 | | | |
| MONIH3 | 1 | 8.100 | . | 8.100 | 8.100 | . | 8.100 | . | . | | | |
| MONIH4 | 0 | | | | | | | | | | | |
| MONIH6 | 2 | 8.850 | 0.778 | 8.300 | 9.400 | 0.550 | 17.700 | 0.605 | 8.78 | | | |
| MONIH9 | 2 | 7.000 | 0.990 | 6.300 | 7.700 | 0.700 | 14.000 | 0.980 | 14.14 | | | |
| MONIH12 | 2 | 6.650 | 0.495 | 6.300 | 7.000 | 0.350 | 13.300 | 0.245 | 7.44 | | | |
| MONIH18 | 2 | 8.300 | 2.404 | 6.600 | 10.000 | 1.700 | 16.600 | 5.780 | 28.96 | | | |
| MONIH24 | 2 | 6.650 | 0.354 | 6.400 | 6.900 | 0.250 | 13.300 | 0.125 | 5.31 | | | |
| MONIH36 | 2 | 2.150 | 0.495 | 1.800 | 2.500 | 0.350 | 4.300 | 0.245 | 23.02 | | | |

AMBERGARD XE-555 STABILITY DATA
DFP VAPOR DESORPTION
& DESORBED

| VARIABLE | N | MEAN | STANDARD DEVIATION | MINIMUM VALUE | MAXIMUM VALUE | STD ERROR OF MEAN | SUM | VARIANCE | C.V |
|----------|---|--------|--------------------|---------------|---------------|-------------------|--------|----------|--------|
| TEMP=40C | | | | | | | | | |
| MNVH0 | 2 | 9.000 | 2.263 | 7.400 | 10.600 | 1.600 | 18.000 | 5.120 | 25.14 |
| MNVH1 | 2 | 12.000 | 2.687 | 10.100 | 13.900 | 1.900 | 24.000 | 7.220 | 22.39 |
| MNVH2 | 2 | 6.350 | 1.909 | 5.000 | 7.700 | 1.350 | 12.700 | 3.645 | 30.06 |
| MNVH3 | 1 | 6.900 | . | 6.900 | 6.900 | . | 6.900 | . | . |
| MNVH4 | 0 | . | . | . | . | . | . | . | . |
| MNVH6 | 2 | 7.300 | 1.556 | 6.200 | 8.400 | 1.100 | 14.600 | 2.420 | 21.31 |
| MNVH9 | 2 | 7.900 | 3.394 | 5.500 | 10.300 | 2.400 | 15.800 | 11.520 | 42.96 |
| MNVH12 | 2 | 9.900 | 0.849 | 9.300 | 10.500 | 0.600 | 19.800 | 0.720 | 8.57 |
| MNVH13 | 2 | 12.750 | 0.919 | 12.100 | 13.400 | 0.650 | 25.500 | 0.845 | 7.21 |
| MNVH24 | 2 | 7.950 | 0.778 | 7.400 | 8.500 | 0.550 | 15.900 | 0.605 | 9.78 |
| MNVH36 | 2 | 4.850 | 1.485 | 3.800 | 5.900 | 1.050 | 9.700 | 2.205 | 30.61 |
| TEMP=60C | | | | | | | | | |
| MNVH0 | 2 | 9.000 | 2.263 | 7.400 | 10.600 | 1.600 | 18.000 | 5.120 | 25.14 |
| MNVH1 | 2 | 10.800 | 3.536 | 8.300 | 13.300 | 2.500 | 21.600 | 12.500 | 32.73 |
| MNVH2 | 2 | 4.850 | 1.061 | 4.100 | 5.600 | 0.750 | 9.700 | 1.125 | 21.86 |
| MNVH3 | 1 | 8.400 | . | 8.400 | 8.400 | . | 8.400 | . | . |
| MNVH4 | 2 | 4.550 | 1.061 | 3.800 | 5.300 | 0.750 | 9.100 | 1.125 | 23.31 |
| MNVH6 | 2 | 9.200 | 0.707 | 8.700 | 9.700 | 0.500 | 18.400 | 0.500 | 7.68 |
| MNVH9 | 2 | 5.550 | 2.333 | 3.900 | 7.200 | 1.650 | 11.100 | 5.445 | 42.04 |
| MNVH12 | 2 | 7.700 | 3.818 | 5.000 | 10.400 | 2.700 | 15.400 | 14.580 | 49.58 |
| MNVH13 | 2 | 8.900 | 0.990 | 8.200 | 9.600 | 0.700 | 17.800 | 0.980 | 11.12 |
| MNVH24 | 2 | 7.050 | 1.768 | 5.800 | 8.300 | 1.250 | 14.100 | 3.125 | 25.07 |
| MNVH36 | 2 | 4.700 | 4.808 | 1.300 | 8.100 | 3.400 | 9.400 | 23.120 | 102.30 |

AMERCARD XE-555 STABILITY DATA
ENSLINN LIQUID SORPTION STORAGE DATA
(SECONDS)

| OBS | TEMP | MONIH0 | MONIH1 | MONIH2 | MONIH3 | MONIH4 | MONIH6 | MONIH9 | MONIH12 | MONIH8 | MONIH24 | MONIH36 |
|-----|------|--------|--------|--------|--------|--------|--------|--------|---------|--------|---------|---------|
| 1 | OC | 31.6 | 24.1 | . | 38.6 | . | 32.7 | 29.5 | 35.5 | 30.7 | 32.3 | 20.7 |
| 2 | OC | 34.2 | . | . | 22.9 | . | 33.9 | 30.0 | 31.1 | 30.9 | 37.0 | 35.2 |
| 3 | OC | 33.5 | . | . | 20.6 | . | 28.2 | 30.5 | 32.4 | 33.5 | 38.8 | 33.0 |
| 4 | OC | . | . | . | 35.7 | . | 28.0 | 30.7 | 32.6 | 31.6 | 29.8 | 51.0 |
| 5 | 25C | 31.6 | 31.8 | 27.7 | 39.7 | . | 35.5 | 39.2 | 32.2 | 31.2 | 42.1 | 26.8 |
| 6 | 25C | 34.2 | . | 29.3 | 28.7 | . | 28.7 | 32.6 | 36.5 | 28.3 | 35.3 | 37.3 |
| 7 | 25C | 33.5 | . | 34.7 | 35.5 | . | 30.5 | 33.7 | 34.5 | 38.0 | 32.0 | 37.9 |
| 8 | 25C | . | . | 28.2 | 28.6 | . | 29.1 | 31.5 | 33.3 | 29.6 | 42.0 | 27.1 |
| 9 | 40C | 31.6 | 30.5 | 29.3 | 31.0 | . | 33.3 | 35.6 | 28.7 | 30.1 | 39.5 | 27.9 |
| 10 | 40C | 34.2 | . | 23.9 | 34.0 | . | 27.9 | 30.4 | 33.5 | 33.3 | 33.2 | 25.4 |
| 11 | 40C | 33.5 | . | 29.2 | 32.2 | . | 26.8 | 36.3 | 34.4 | 30.0 | 32.4 | 23.1 |
| 12 | 40C | . | . | 26.5 | 22.1 | . | 31.1 | 36.4 | 31.1 | 34.0 | 30.1 | 31.8 |
| 13 | 60C | 31.6 | 30.8 | 30.9 | 30.1 | 29.9 | 37.2 | 31.7 | 30.6 | 33.5 | 33.7 | 33.5 |
| 14 | 60C | 34.2 | . | 32.3 | 34.9 | 32.9 | 31.6 | 33.5 | 30.9 | 29.5 | 33.9 | 28.6 |
| 15 | 60C | 33.5 | . | 30.4 | 36.0 | 33.1 | 31.6 | 31.7 | 31.0 | 27.6 | 30.7 | 30.1 |
| 16 | 60C | . | . | 34.0 | 38.1 | 32.0 | 31.2 | 30.0 | 31.0 | 28.8 | 34.9 | 30.4 |

| VARIABLE | N | MEAN | STANDARD DEVIATION | MINIMUM VALUE | MAXIMUM VALUE | STD ERROR OF MEAN | SUM | VARIANCE | C.V |
|----------|---|--------|--------------------|---------------|---------------|-------------------|---------|----------|-------|
| MONIH0 | 3 | 33.100 | 1.345 | 31.600 | 34.200 | 0.777 | 99.300 | 1.810 | 4.06 |
| MONIH1 | 1 | 24.100 | . | 24.100 | 24.100 | . | 24.100 | . | . |
| MONIH2 | 0 | . | . | . | . | . | . | . | . |
| MONIH3 | 4 | 29.450 | 9.019 | 20.600 | 38.600 | 4.509 | 117.800 | 81.337 | 30.62 |
| MONIH4 | 0 | . | . | . | . | . | . | . | . |
| MONIH5 | 4 | 30.700 | 3.043 | 28.000 | 33.900 | 1.522 | 122.800 | 9.260 | 9.91 |
| MONIH9 | 4 | 30.175 | 0.538 | 29.500 | 30.700 | 0.269 | 120.700 | 0.289 | 1.78 |
| MONIH12 | 4 | 32.900 | 1.857 | 31.100 | 35.500 | 0.928 | 131.600 | 3.447 | 5.64 |
| MONIH18 | 4 | 31.675 | 1.276 | 30.700 | 33.500 | 0.638 | 126.700 | 1.629 | 4.03 |
| MONIH24 | 4 | 34.475 | 4.150 | 29.800 | 38.800 | 2.075 | 137.900 | 17.223 | 12.03 |
| MONIH36 | 4 | 34.975 | 12.444 | 20.700 | 51.000 | 6.222 | 139.900 | 154.842 | 35.57 |

TEMP-OC

AMBERCARD XE-555 STABILITY DATA
ENSLIN LIQUID SORPTION STORAGE DATA

| VARIABLE | N | MEAN | STANDARD DEVIATION | MINIMUM VALUE | MAXIMUM VALUE | STD ERROR OF MEAN | SUM | VARIANCE | C.V |
|----------|---|--------|--------------------|---------------|---------------|-------------------|---------|----------|-------|
| TEMP=25C | | | | | | | | | |
| MONIH0 | 3 | 33.100 | 1.345 | 31.600 | 34.200 | 0.777 | 99.300 | 1.810 | 4.06 |
| MONIH1 | 1 | 31.800 | | 31.800 | 31.800 | | 31.800 | | |
| MONIH2 | 4 | 29.975 | 3.220 | 27.700 | 34.700 | 1.610 | 119.900 | 10.363 | 10.74 |
| MONIH3 | 4 | 33.125 | 5.444 | 28.600 | 39.700 | 2.722 | 132.500 | 29.642 | 16.43 |
| MONIH4 | 0 | | | | | | | | |
| MONIH6 | 4 | 30.950 | 3.130 | 28.700 | 35.500 | 1.565 | 123.600 | 9.797 | 10.11 |
| MONIH9 | 4 | 34.250 | 3.420 | 31.500 | 39.200 | 1.710 | 137.000 | 11.697 | 9.98 |
| MONIH12 | 4 | 34.125 | 1.841 | 32.200 | 36.500 | 0.920 | 136.500 | 3.389 | 5.39 |
| MONIH18 | 4 | 31.775 | 4.316 | 28.200 | 38.000 | 2.158 | 127.100 | 18.629 | 13.58 |
| MONIH24 | 4 | 37.850 | 5.034 | 32.000 | 42.100 | 2.517 | 151.400 | 25.337 | 13.29 |
| MONIH36 | 4 | 32.275 | 6.155 | 26.800 | 37.900 | 3.077 | 129.100 | 37.882 | 19.07 |

| VARIABLE | N | MEAN | STANDARD DEVIATION | MINIMUM VALUE | MAXIMUM VALUE | STD ERROR OF MEAN | SUM | VARIANCE | C.V |
|----------|---|--------|--------------------|---------------|---------------|-------------------|---------|----------|-------|
| TEMP=40C | | | | | | | | | |
| MONIH0 | 3 | 33.100 | 1.345 | 31.600 | 34.200 | 0.777 | 99.300 | 1.810 | 4.06 |
| MONIH1 | 1 | 30.500 | | 30.500 | 30.500 | | 30.500 | | |
| MONIH2 | 4 | 27.225 | 2.568 | 23.900 | 29.300 | 1.284 | 108.900 | 6.596 | 9.43 |
| MONIH3 | 4 | 29.825 | 5.296 | 22.100 | 34.000 | 2.648 | 119.300 | 28.043 | 17.75 |
| MONIH4 | 0 | | | | | | | | |
| MONIH6 | 4 | 29.775 | 2.975 | 26.800 | 33.300 | 1.487 | 119.100 | 8.849 | 9.99 |
| MONIH9 | 4 | 34.675 | 2.872 | 30.400 | 36.400 | 1.436 | 138.700 | 8.249 | 8.28 |
| MONIH12 | 4 | 31.925 | 2.562 | 28.700 | 34.400 | 1.281 | 127.700 | 6.563 | 8.02 |
| MONIH18 | 4 | 31.850 | 2.098 | 30.000 | 34.000 | 1.049 | 127.400 | 4.403 | 6.53 |
| MONIH24 | 4 | 33.800 | 4.021 | 30.100 | 39.500 | 2.010 | 135.200 | 16.167 | 11.89 |
| MONIH36 | 4 | 27.050 | 3.724 | 23.100 | 31.800 | 1.862 | 108.200 | 13.870 | 13.76 |

AMBERGARD XE-555 STABILITY DATA
ENSLIN LIQUID SORPTION STORAGE DATA

| VARIABLE | N | MEAN | STANDARD DEVIATION | MINIMUM VALUE | MAXIMUM VALUE | STD ERROR OF MEAN | SUM | VARIANCE | C.V |
|----------|---|--------|-----------------------|------------------|------------------|----------------------|---------|----------|------|
| | | | | TEMP=60C | | | | | |
| MONIH0 | 3 | 33.100 | 1.345 | 31.600 | 34.200 | 0.777 | 99.300 | 1.810 | 4.06 |
| MONIH1 | 1 | 30.800 | | 30.800 | 30.800 | | 30.800 | | |
| MONIH2 | 4 | 31.900 | 1.615 | 30.400 | 34.000 | 0.807 | 127.600 | 2.607 | 5.06 |
| MONIH3 | 4 | 34.775 | 3.388 | 30.100 | 38.100 | 1.694 | 139.100 | 11.476 | 9.74 |
| MONIH4 | 4 | 31.975 | 1.464 | 29.900 | 33.100 | 0.732 | 127.900 | 2.142 | 4.57 |
| MONIH6 | 4 | 32.900 | 2.873 | 31.200 | 37.200 | 1.436 | 131.600 | 8.253 | 8.73 |
| MONIH9 | 4 | 31.725 | 1.429 | 30.000 | 33.500 | 0.715 | 126.900 | 2.042 | 4.50 |
| MONIH12 | 4 | 30.875 | 0.189 | 30.600 | 31.000 | 0.095 | 123.500 | 0.036 | 0.51 |
| MONIH8 | 4 | 29.850 | 2.557 | 27.600 | 33.500 | 1.278 | 119.400 | 6.537 | 8.56 |
| MONIH24 | 4 | 33.300 | 1.811 | 30.700 | 34.900 | 0.906 | 133.200 | 3.280 | 5.43 |
| MONIH6 | 4 | 30.650 | 2.057 | 28.600 | 33.500 | 1.028 | 122.600 | 4.230 | 6.71 |

KINETIC IODINE STORAGE DATA
* TRANSMITTANCE

| OBS | TEMP | MONIH0 | MONIH1 | MONIH2 | MONIH3 | MONIH4 | MONIH6 | MONIH9 | MONIH12 | MONIH8 | MONIH24 | N | MEAN | STANDARD DEVIATION | MINIMUM VALUE | MAXIMUM VALUE | STD ERROR OF MEAN | SUM | VARIANCE | C.V |
|-----|------|--------|--------|--------|--------|--------|--------|--------|---------|--------|---------|---|--------|--------------------|---------------|---------------|-------------------|--------|----------|-------|
| 1 | OC | 22 | 24.3 | . | 10 | . | 7.0 | 14 | 7.5 | 8.0 | 2.4 | 2 | 21.500 | 0.707 | 21.000 | 22.000 | 0.500 | 43.000 | 0.500 | 3.28 |
| 2 | OC | 21 | 28.0 | . | 9 | . | 7.5 | 12 | 9.5 | 8.0 | 1.8 | 2 | 26.150 | 2.616 | 24.300 | 28.000 | 1.850 | 52.300 | 6.845 | 10.00 |
| 3 | 25C | 22 | 23.8 | 14 | 7 | . | 7.5 | 9 | 6.5 | 6.0 | 1.2 | 0 | 9.500 | 0.707 | 9.000 | 10.000 | 0.500 | 19.000 | 0.500 | 7.44 |
| 4 | 25C | 21 | 22.4 | 14 | 6 | . | 7.5 | 10 | 7.5 | 7.0 | 0.6 | 2 | 7.250 | 0.354 | 7.000 | 7.500 | 0.250 | 14.500 | 0.125 | 4.87 |
| 5 | 40C | 22 | 18.2 | 7 | 5 | . | 7.5 | 7 | 6.0 | 6.0 | 1.8 | 2 | 13.000 | 1.414 | 12.000 | 14.000 | 1.000 | 26.000 | 2.000 | 10.87 |
| 6 | 40C | 21 | 17.0 | 8 | 6 | . | 7.0 | 7 | 7.5 | 7.0 | 1.8 | 2 | 8.000 | 0.707 | 7.500 | 8.500 | 0.500 | 16.000 | 0.500 | 8.83 |
| 7 | 60C | 22 | 22.9 | 9 | 7 | 5 | 8.5 | 17 | 6.0 | 6.5 | 1.8 | 2 | 8.000 | 0.000 | 8.000 | 8.000 | 0.000 | 16.000 | 0.000 | 0.00 |
| 8 | 60C | 21 | 19.8 | 10 | 6 | 6 | 8.5 | 18 | 17.0 | 17.0 | 14.4 | 2 | 2.100 | 0.424 | 1.800 | 2.400 | 0.300 | 4.200 | 0.180 | 20.20 |

TEMP=OC

| VARIABLE | MONIH0 | MONIH1 | MONIH2 | MONIH3 | MONIH4 | MONIH6 | MONIH9 | MONIH12 | MONIH8 | MONIH24 | N | MEAN | STANDARD DEVIATION | MINIMUM VALUE | MAXIMUM VALUE | STD ERROR OF MEAN | SUM | VARIANCE | C.V |
|----------|--------|--------|--------|--------|--------|--------|--------|---------|--------|---------|---|--------|--------------------|---------------|---------------|-------------------|--------|----------|-------|
| MONIH0 | 2 | 2 | 2 | 0 | 2 | 0 | 2 | 2 | 2 | 2 | 2 | 21.500 | 0.707 | 21.000 | 22.000 | 0.500 | 43.000 | 0.500 | 3.28 |
| MONIH1 | 2 | 2 | 2 | 0 | 2 | 0 | 2 | 2 | 2 | 2 | 2 | 26.150 | 2.616 | 24.300 | 28.000 | 1.850 | 52.300 | 6.845 | 10.00 |
| MONIH2 | 0 | 2 | 2 | 2 | 2 | 0 | 2 | 2 | 2 | 2 | 2 | 9.500 | 0.707 | 9.000 | 10.000 | 0.500 | 19.000 | 0.500 | 7.44 |
| MONIH3 | 0 | 2 | 2 | 2 | 2 | 0 | 2 | 2 | 2 | 2 | 2 | 7.250 | 0.354 | 7.000 | 7.500 | 0.250 | 14.500 | 0.125 | 4.87 |
| MONIH4 | 2 | 2 | 2 | 2 | 2 | 2 | 2 | 2 | 2 | 2 | 2 | 13.000 | 1.414 | 12.000 | 14.000 | 1.000 | 26.000 | 2.000 | 10.87 |
| MONIH6 | 2 | 2 | 2 | 2 | 2 | 2 | 2 | 2 | 2 | 2 | 2 | 8.000 | 0.707 | 7.500 | 8.500 | 0.500 | 16.000 | 0.500 | 8.83 |
| MONIH9 | 2 | 2 | 2 | 2 | 2 | 2 | 2 | 2 | 2 | 2 | 2 | 8.000 | 0.000 | 8.000 | 8.000 | 0.000 | 16.000 | 0.000 | 0.00 |
| MONIH12 | 2 | 2 | 2 | 2 | 2 | 2 | 2 | 2 | 2 | 2 | 2 | 2.100 | 0.424 | 1.800 | 2.400 | 0.300 | 4.200 | 0.180 | 20.20 |

TEMP=25C

| VARIABLE | MONIH0 | MONIH1 | MONIH2 | MONIH3 | MONIH4 | MONIH6 | MONIH9 | MONIH12 | MONIH8 | MONIH24 | N | MEAN | STANDARD DEVIATION | MINIMUM VALUE | MAXIMUM VALUE | STD ERROR OF MEAN | SUM | VARIANCE | C.V |
|----------|--------|--------|--------|--------|--------|--------|--------|---------|--------|---------|---|--------|--------------------|---------------|---------------|-------------------|--------|----------|-------|
| MONIH0 | 2 | 2 | 2 | 0 | 2 | 0 | 2 | 2 | 2 | 2 | 2 | 21.500 | 0.707 | 21.000 | 22.000 | 0.500 | 43.000 | 0.500 | 3.28 |
| MONIH1 | 2 | 2 | 2 | 2 | 2 | 0 | 2 | 2 | 2 | 2 | 2 | 23.100 | 0.990 | 22.400 | 23.800 | 0.700 | 46.200 | 0.980 | 4.28 |
| MONIH2 | 2 | 2 | 2 | 2 | 2 | 0 | 2 | 2 | 2 | 2 | 2 | 14.000 | 0.000 | 14.000 | 14.000 | 0.000 | 28.000 | 0.000 | 0.00 |
| MONIH3 | 2 | 2 | 2 | 2 | 2 | 0 | 2 | 2 | 2 | 2 | 2 | 6.500 | 0.707 | 6.000 | 7.000 | 0.500 | 13.000 | 0.500 | 10.87 |
| MONIH4 | 0 | 2 | 2 | 2 | 2 | 0 | 2 | 2 | 2 | 2 | 2 | 7.500 | 0.000 | 7.500 | 7.500 | 0.000 | 15.000 | 0.000 | 0.00 |
| MONIH6 | 2 | 2 | 2 | 2 | 2 | 0 | 2 | 2 | 2 | 2 | 2 | 9.500 | 0.707 | 9.000 | 10.000 | 0.500 | 19.000 | 0.500 | 7.44 |
| MONIH9 | 2 | 2 | 2 | 2 | 2 | 0 | 2 | 2 | 2 | 2 | 2 | 7.000 | 0.707 | 6.500 | 7.500 | 0.500 | 14.000 | 0.500 | 10.10 |
| MONIH12 | 2 | 2 | 2 | 2 | 2 | 0 | 2 | 2 | 2 | 2 | 2 | 6.500 | 0.707 | 6.000 | 7.000 | 0.500 | 13.000 | 0.500 | 10.87 |
| MONIH8 | 2 | 2 | 2 | 2 | 2 | 0 | 2 | 2 | 2 | 2 | 2 | 0.900 | 0.424 | 0.600 | 1.200 | 0.300 | 1.800 | 0.180 | 47.14 |

KINETIC IODINE STORAGE DATA
% TRANSMITTANCE

| VARIABLE | N | MEAN | STANDARD DEVIATION | MINIMUM VALUE | MAXIMUM VALUE | STD ERROR OF MEAN | SUM | VARIANCE | C.V |
|----------|---|--------|--------------------|---------------|---------------|-------------------|--------|----------|-------|
| TEMP=40C | | | | | | | | | |
| MONIH0 | 2 | 21.500 | 0.707 | 21.000 | 22.000 | 0.500 | 43.000 | 0.500 | 3.28 |
| MONIH1 | 2 | 17.600 | 0.949 | 17.000 | 18.200 | 0.600 | 35.200 | 0.720 | 4.82 |
| MONIH2 | 2 | 7.500 | 0.707 | 7.000 | 8.000 | 0.500 | 15.000 | 0.500 | 9.42 |
| MONIH3 | 2 | 5.500 | 0.707 | 5.000 | 6.000 | 0.500 | 11.000 | 0.500 | 12.85 |
| MONIH4 | 0 | | | | | | | | |
| MONIH6 | 2 | 7.250 | 0.354 | 7.000 | 7.500 | 0.250 | 14.500 | 0.125 | 4.87 |
| MONIH9 | 2 | 7.000 | 0.000 | 7.000 | 7.000 | 0.000 | 14.000 | 0.000 | 0.00 |
| MONIH12 | 2 | 6.000 | 0.000 | 6.000 | 6.000 | 0.000 | 12.000 | 0.000 | 0.00 |
| MONIH18 | 2 | 6.250 | 0.354 | 6.000 | 6.500 | 0.250 | 12.500 | 0.125 | 5.65 |
| MONIH24 | 2 | 1.800 | 0.000 | 1.800 | 1.800 | 0.000 | 3.600 | 0.000 | 0.00 |

TEMP=60C

| | | | | | | | | | |
|---------|---|--------|-------|--------|--------|-------|--------|-------|-------|
| MONIH0 | 2 | 21.500 | 0.707 | 21.000 | 22.000 | 0.500 | 43.000 | 0.500 | 3.28 |
| MONIH1 | 2 | 21.350 | 2.192 | 19.300 | 22.900 | 1.550 | 42.700 | 4.805 | 10.25 |
| MONIH2 | 2 | 9.500 | 0.707 | 9.000 | 10.000 | 0.500 | 19.000 | 0.500 | 7.44 |
| MONIH3 | 2 | 6.500 | 0.707 | 6.000 | 7.000 | 0.500 | 13.000 | 0.500 | 10.87 |
| MONIH4 | 2 | 5.500 | 0.707 | 5.000 | 6.000 | 0.500 | 11.000 | 0.500 | 12.85 |
| MONIH6 | 2 | 8.500 | 0.000 | 8.500 | 8.500 | 0.000 | 17.000 | 0.000 | 0.00 |
| MONIH9 | 2 | 17.500 | 0.707 | 17.000 | 18.000 | 0.500 | 35.000 | 0.500 | 4.04 |
| MONIH12 | 2 | 17.000 | 0.000 | 17.000 | 17.000 | 0.000 | 34.000 | 0.000 | 0.00 |
| MONIH18 | 2 | 17.500 | 0.707 | 17.000 | 18.000 | 0.500 | 35.000 | 0.500 | 4.04 |
| MONIH24 | 2 | 14.300 | 0.141 | 14.200 | 14.400 | 0.100 | 28.600 | 0.020 | 0.98 |

AMBERGARD XE-555 STABILITY DATA
 BASICITY STORAGE DATA (MEQ/GM, AS IS)

| OBS | TEMP | MONIH0 | MONIH1 | MONIH2 | MONIH3 | MONIH4 | MONIH5 | MONIH6 | MONIH9 | MONIH12 | MONIH18 | MONIH24 | MONIH36 |
|-----|------|--------|--------|--------|--------|--------|--------|--------|--------|---------|---------|---------|---------|
| 1 | 0C | 0.640 | 0.667 | . | 0.642 | . | 0.614 | 0.642 | 0.642 | 0.653 | 0.622 | 0.660 | 0.647 |
| 2 | 0C | 0.644 | 0.684 | . | 0.638 | . | 0.604 | 0.638 | 0.638 | 0.648 | 0.629 | 0.566 | 0.645 |
| 3 | 25C | 0.640 | 0.682 | 0.668 | 0.616 | . | 0.618 | 0.640 | 0.640 | 0.661 | 0.618 | 0.641 | 0.629 |
| 4 | 25C | 0.644 | 0.690 | 0.665 | 0.631 | . | 0.612 | 0.638 | 0.638 | 0.639 | 0.615 | 0.630 | 0.624 |
| 5 | 40C | 0.640 | 0.658 | 0.626 | 0.630 | . | 0.583 | 0.609 | 0.609 | 0.605 | 0.586 | 0.629 | 0.538 |
| 6 | 40C | 0.644 | 0.649 | 0.642 | 0.615 | . | 0.584 | 0.593 | 0.593 | 0.596 | 0.582 | 0.614 | 0.589 |
| 7 | 60C | 0.640 | 0.657 | 0.630 | 0.608 | 0.563 | 0.552 | 0.600 | 0.600 | 0.585 | 0.558 | 0.592 | 0.535 |
| 8 | 60C | 0.644 | 0.645 | 0.614 | 0.591 | 0.563 | 0.552 | 0.597 | 0.597 | 0.588 | 0.552 | 0.616 | 0.541 |

| VARIABLE | N | MEAN | STANDARD DEVIATION | MINIMUM VALUE | MAXIMUM VALUE | STD ERROR OF MEAN | SUM | VARIANCE | C.V |
|----------|---|------|--------------------|---------------|---------------|-------------------|-----|----------|-----|
|----------|---|------|--------------------|---------------|---------------|-------------------|-----|----------|-----|

TEMP=0C

| | | | | | | | | | |
|---------|---|-------|-------|-------|-------|-------|-------|-------|------|
| MONIH0 | 2 | 0.642 | 0.003 | 0.640 | 0.644 | 0.002 | 1.284 | 0.000 | 0.44 |
| MONIH1 | 2 | 0.675 | 0.012 | 0.667 | 0.684 | 0.003 | 1.351 | 0.000 | 1.78 |
| MONIH2 | 0 | | | | | | | | |
| MONIH3 | 2 | 0.640 | 0.003 | 0.638 | 0.642 | 0.002 | 1.280 | 0.000 | 0.44 |
| MONIH4 | 0 | | | | | | | | |
| MONIH5 | 2 | 0.609 | 0.007 | 0.604 | 0.614 | 0.005 | 1.218 | 0.000 | 1.16 |
| MONIH6 | 2 | 0.640 | 0.003 | 0.638 | 0.642 | 0.002 | 1.280 | 0.000 | 0.44 |
| MONIH12 | 2 | 0.650 | 0.004 | 0.648 | 0.653 | 0.002 | 1.301 | 0.000 | 0.54 |
| MONIH18 | 2 | 0.625 | 0.005 | 0.622 | 0.629 | 0.004 | 1.251 | 0.000 | 0.79 |
| MONIH24 | 2 | 0.663 | 0.004 | 0.660 | 0.666 | 0.003 | 1.326 | 0.000 | 0.64 |
| MONIH36 | 2 | 0.646 | 0.001 | 0.645 | 0.647 | 0.001 | 1.292 | 0.000 | 0.21 |

TEMP=25C

| | | | | | | | | | |
|---------|---|-------|-------|-------|-------|-------|-------|-------|------|
| MONIH0 | 2 | 0.642 | 0.003 | 0.640 | 0.644 | 0.002 | 1.284 | 0.000 | 0.44 |
| MONIH1 | 2 | 0.686 | 0.006 | 0.682 | 0.690 | 0.004 | 1.372 | 0.000 | 0.82 |
| MONIH2 | 2 | 0.666 | 0.002 | 0.665 | 0.668 | 0.001 | 1.333 | 0.000 | 0.31 |
| MONIH3 | 2 | 0.623 | 0.011 | 0.616 | 0.631 | 0.008 | 1.247 | 0.000 | 1.70 |
| MONIH4 | 0 | | | | | | | | |
| MONIH5 | 2 | 0.615 | 0.004 | 0.612 | 0.618 | 0.003 | 1.230 | 0.000 | 0.69 |
| MONIH6 | 2 | 0.639 | 0.001 | 0.638 | 0.640 | 0.001 | 1.273 | 0.000 | 0.22 |
| MONIH12 | 2 | 0.650 | 0.016 | 0.639 | 0.661 | 0.011 | 1.300 | 0.000 | 2.39 |
| MONIH18 | 2 | 0.616 | 0.002 | 0.615 | 0.618 | 0.001 | 1.233 | 0.000 | 0.34 |
| MONIH24 | 2 | 0.635 | 0.008 | 0.630 | 0.641 | 0.005 | 1.271 | 0.000 | 1.22 |
| MONIH36 | 2 | 0.626 | 0.004 | 0.624 | 0.629 | 0.002 | 1.253 | 0.000 | 0.56 |

AMERGARD XE-555 STABILITY DATA
 BASICITY STORAGE DATA (MO/GA, AS IS)

| VARIABLE | N | MEAN | STANDARD DEVIATION | MINIMUM VALUE | MAXIMUM VALUE | STD ERROR OF MEAN | SUM | VARIANCE | C.V |
|----------|---|-------|--------------------|---------------|---------------|-------------------|-------|----------|------|
| TEMP=40C | | | | | | | | | |
| MONI10 | 2 | 0.642 | 0.003 | 0.640 | 0.644 | 0.002 | 1.284 | 0.000 | 0.44 |
| MONI11 | 2 | 0.653 | 0.006 | 0.649 | 0.658 | 0.004 | 1.307 | 0.000 | 0.97 |
| MONI12 | 2 | 0.634 | 0.011 | 0.626 | 0.642 | 0.008 | 1.268 | 0.000 | 1.78 |
| MONI13 | 2 | 0.622 | 0.011 | 0.615 | 0.630 | 0.007 | 1.245 | 0.000 | 1.70 |
| MONI14 | 0 | | | | | | | | |
| MONI16 | 2 | 0.593 | 0.001 | 0.593 | 0.584 | 0.001 | 1.167 | 0.000 | 0.12 |
| MONI19 | 2 | 0.601 | 0.011 | 0.593 | 0.609 | 0.008 | 1.202 | 0.000 | 1.98 |
| MONI12 | 2 | 0.600 | 0.006 | 0.596 | 0.605 | 0.004 | 1.201 | 0.000 | 1.06 |
| MONI18 | 2 | 0.584 | 0.003 | 0.582 | 0.586 | 0.002 | 1.168 | 0.000 | 0.48 |
| MONI24 | 2 | 0.621 | 0.011 | 0.614 | 0.629 | 0.007 | 1.243 | 0.000 | 1.70 |
| MONI36 | 2 | 0.588 | 0.001 | 0.588 | 0.589 | 0.001 | 1.177 | 0.000 | 0.12 |
| TEMP=60C | | | | | | | | | |
| MONI10 | 2 | 0.642 | 0.003 | 0.640 | 0.644 | 0.002 | 1.284 | 0.000 | 0.44 |
| MONI11 | 2 | 0.651 | 0.008 | 0.645 | 0.657 | 0.006 | 1.302 | 0.000 | 1.50 |
| MONI12 | 2 | 0.622 | 0.011 | 0.614 | 0.630 | 0.008 | 1.244 | 0.000 | 1.81 |
| MONI13 | 2 | 0.599 | 0.012 | 0.591 | 0.608 | 0.008 | 1.199 | 0.000 | 2.00 |
| MONI14 | 2 | 0.563 | 0.000 | 0.563 | 0.563 | 0.000 | 1.126 | 0.000 | 0.00 |
| MONI16 | 2 | 0.552 | 0.000 | 0.552 | 0.552 | 0.000 | 1.104 | 0.000 | 0.90 |
| MONI19 | 2 | 0.598 | 0.002 | 0.597 | 0.600 | 0.001 | 1.197 | 0.000 | 0.35 |
| MONI12 | 2 | 0.586 | 0.002 | 0.585 | 0.588 | 0.002 | 1.173 | 0.000 | 0.36 |
| MONI18 | 2 | 0.555 | 0.004 | 0.552 | 0.550 | 0.003 | 1.110 | 0.000 | 0.76 |
| MONI24 | 2 | 0.604 | 0.017 | 0.592 | 0.616 | 0.012 | 1.208 | 0.000 | 2.81 |
| MONI36 | 2 | 0.538 | 0.004 | 0.535 | 0.541 | 0.003 | 1.076 | 0.000 | 0.78 |

AMERGARD XE-555 STABILITY DATA
ACIDITY STORAGE DATA (MO/CM, AS IS)

| OBS | TEMP | MONIH0 | MONIH1 | MONIH2 | MONIH3 | MONIH4 | MONIH5 | MONIH6 | MONIH9 | MONIH12 | MONIH8 | MONIH24 | MONIH6 |
|----------|------|--------|--------|--------------------|---------------|---------------|-------------------|--------|----------|---------|--------|---------|--------|
| VARIABLE | | N | MEAN | STANDARD DEVIATION | MINIMUM VALUE | MAXIMUM VALUE | SID ERROR OF MEAN | SIM | VARIANCE | C.V | | | |
| 1 | 0C | 0.761 | 0.735 | | 0.731 | 0.662 | 0.744 | 0.780 | 0.600 | 0.716 | 0.768 | | |
| 2 | 0C | 0.759 | 0.727 | | 0.695 | 0.641 | 0.728 | 0.795 | 0.722 | 0.742 | 0.762 | | |
| 3 | 25C | 0.761 | 0.736 | 0.806 | 0.703 | 0.668 | 0.739 | 0.762 | 0.736 | 0.716 | 0.740 | | |
| 4 | 25C | 0.759 | 0.726 | 0.804 | 0.707 | 0.570 | 0.752 | 0.779 | 0.733 | 0.750 | 0.743 | | |
| 5 | 40C | 0.761 | 0.749 | 0.755 | 0.746 | 0.673 | 0.719 | 0.752 | 0.764 | 0.749 | 0.733 | | |
| 6 | 40C | 0.759 | 0.723 | 0.764 | 0.724 | 0.686 | 0.722 | 0.769 | 0.713 | 0.736 | 0.729 | | |
| 7 | 60C | 0.761 | 0.855 | 0.902 | 0.811 | 0.761 | 0.986 | 0.982 | 1.070 | 1.110 | 1.114 | | |
| 8 | 60C | 0.759 | 0.878 | 0.902 | 0.813 | 0.782 | 0.980 | 0.976 | 1.044 | 1.117 | 1.112 | | |

TEMP-2C

| | | | | | | | | | |
|---------|---|-------|-------|-------|-------|-------|-------|-------|-------|
| MONIH0 | 2 | 0.760 | 0.001 | 0.759 | 0.761 | 0.001 | 1.520 | 0.000 | 0.18 |
| MONIH1 | 2 | 0.731 | 0.006 | 0.727 | 0.735 | 0.004 | 1.462 | 0.000 | 0.77 |
| MONIH2 | 0 | | | | | | | | |
| MONIH3 | 2 | 0.713 | 0.025 | 0.695 | 0.731 | 0.018 | 1.426 | 0.001 | 3.57 |
| MONIH4 | 0 | | | | | | | | |
| MONIH5 | 2 | 0.651 | 0.015 | 0.641 | 0.662 | 0.010 | 1.303 | 0.000 | 2.27 |
| MONIH6 | 2 | 0.736 | 0.011 | 0.728 | 0.744 | 0.006 | 1.472 | 0.000 | 1.53 |
| MONIH7 | 2 | 0.787 | 0.011 | 0.780 | 0.795 | 0.008 | 1.575 | 0.000 | 1.34 |
| MONIH8 | 2 | 0.661 | 0.086 | 0.600 | 0.722 | 0.031 | 1.322 | 0.007 | 13.05 |
| MONIH24 | 2 | 0.729 | 0.018 | 0.716 | 0.742 | 0.013 | 1.458 | 0.000 | 2.52 |
| MONIH6 | 2 | 0.765 | 0.001 | 0.762 | 0.768 | 0.003 | 1.530 | 0.000 | 0.55 |

TEMP-25C

| | | | | | | | | | |
|---------|---|-------|-------|-------|-------|-------|-------|-------|---------------------|
| MONIH0 | 2 | 0.760 | 0.001 | 0.759 | 0.761 | 0.001 | 1.520 | 0.000 | 0.18 |
| MONIH1 | 2 | 0.733 | 0.007 | 0.728 | 0.735 | 0.005 | 1.466 | 0.000 | 0.96 |
| MONIH2 | 2 | 0.805 | 0.001 | 0.804 | 0.806 | 0.001 | 1.610 | 0.000 | 0.17 |
| MONIH3 | 2 | 0.705 | 0.003 | 0.703 | 0.707 | 0.002 | 1.410 | 0.000 | 0.40 |
| MONIH4 | 0 | | | | | | | | |
| MONIH5 | 2 | 0.669 | 0.001 | 0.668 | 0.670 | 0.001 | 1.338 | 0.000 | 0.21 |
| MONIH6 | 2 | 0.745 | 0.009 | 0.739 | 0.752 | 0.007 | 1.491 | 0.000 | 1.23 |
| MONIH7 | 2 | 0.770 | 0.012 | 0.762 | 0.779 | 0.009 | 1.541 | 0.000 | 1.56 |
| MONIH8 | 2 | 0.734 | 0.002 | 0.733 | 0.736 | 0.001 | 1.469 | 0.000 | 0.28 |
| MONIH24 | 2 | 0.733 | 0.024 | 0.716 | 0.750 | 0.017 | 1.466 | 0.001 | 3.28 ^{1/2} |
| MONIH6 | 2 | 0.741 | 0.002 | 0.740 | 0.743 | 0.002 | 1.483 | 0.000 | 0.28 |

AMEERDAR ME-555 SIMILITIVITY DATA
ACIDITY STORAGE DATA (NOV/84, AS IS)

| VARIABLE | N | MEAN | STANDARD DEVIATION | MINIMUM VALUE | MAXIMUM VALUE | STD ERROR OF MEAN | SIM | VARIANCE | C.V |
|----------|---|-------|--------------------|---------------|---------------|-------------------|-------|----------|------|
| TEMP=40C | | | | | | | | | |
| MONIH0 | 2 | 0.760 | 0.001 | 0.759 | 0.761 | 0.001 | 1.520 | 0.000 | 0.18 |
| MONIH1 | 2 | 0.738 | 0.015 | 0.728 | 0.749 | 0.010 | 1.477 | 0.000 | 2.01 |
| MONIH2 | 2 | 0.759 | 0.006 | 0.755 | 0.764 | 0.003 | 1.519 | 0.000 | 0.83 |
| MONIH3 | 2 | 0.735 | 0.016 | 0.724 | 0.746 | 0.011 | 1.470 | 0.000 | 2.11 |
| MONIH4 | 0 | | | | | | | | |
| MONIH5 | 2 | 0.675 | 0.009 | 0.673 | 0.686 | 0.007 | 1.359 | 0.000 | 1.35 |
| MONIH6 | 2 | 0.720 | 0.002 | 0.719 | 0.722 | 0.002 | 1.441 | 0.000 | 0.29 |
| MONIH12 | 2 | 0.760 | 0.012 | 0.752 | 0.769 | 0.009 | 1.521 | 0.000 | 1.53 |
| MONIH18 | 2 | 0.708 | 0.006 | 0.704 | 0.713 | 0.005 | 1.417 | 0.000 | 0.89 |
| MONIH24 | 2 | 0.742 | 0.009 | 0.736 | 0.749 | 0.006 | 1.485 | 0.000 | 1.23 |
| MONIH36 | 2 | 0.731 | 0.003 | 0.729 | 0.733 | 0.002 | 1.462 | 0.000 | 0.38 |
| TEMP=60C | | | | | | | | | |
| MONIH0 | 2 | 0.760 | 0.001 | 0.759 | 0.761 | 0.001 | 1.520 | 0.000 | 0.18 |
| MONIH1 | 2 | 0.866 | 0.016 | 0.855 | 0.878 | 0.012 | 1.733 | 0.000 | 1.87 |
| MONIH2 | 2 | 0.902 | 0.000 | 0.902 | 0.902 | 0.000 | 1.804 | 0.000 | 0.00 |
| MONIH3 | 2 | 0.837 | 0.006 | 0.833 | 0.841 | 0.004 | 1.674 | 0.000 | 0.67 |
| MONIH4 | 2 | 0.739 | 0.002 | 0.738 | 0.741 | 0.002 | 1.479 | 0.000 | 0.28 |
| MONIH6 | 2 | 0.771 | 0.015 | 0.761 | 0.782 | 0.011 | 1.543 | 0.000 | 1.92 |
| MONIH9 | 2 | 0.983 | 0.004 | 0.980 | 0.986 | 0.003 | 1.966 | 0.000 | 0.43 |
| MONIH12 | 2 | 0.979 | 0.004 | 0.976 | 0.982 | 0.003 | 1.958 | 0.000 | 0.43 |
| MONIH18 | 2 | 1.057 | 0.018 | 1.044 | 1.070 | 0.013 | 2.114 | 0.000 | 1.73 |
| MONIH24 | 2 | 1.113 | 0.005 | 1.110 | 1.117 | 0.004 | 2.227 | 0.000 | 0.44 |
| MONIH36 | 2 | 1.113 | 0.001 | 1.112 | 1.114 | 0.001 | 2.226 | 0.000 | 0.12 |

APPENDIX 8

KYDEX SHEET SURFACE AREA T-TEST RESULTS

-----T-Tests-----

Date/Time 10-23-1991 07:51:23
 Data Base Name C:\solo\Kydex
 Description Data base created at 07:44:32 on 10-23-1991

Two Sample T-Test Results

| | CCC20 | | RDL20 | |
|---------------------|----------|----------|----------|----------|
| Count - Mean | 8 | 95.1675 | 9 | 95.79112 |
| 95% C.L. of Mean | 94.11392 | 96.22109 | 94.81882 | 96.75341 |
| Std.Dev - Std.Error | 1.264163 | .446949 | 1.265716 | .4219052 |

| | ----- Equal Variances ----- | | ----- Unequal Variances ----- | |
|--------------------|-----------------------------|----------|-------------------------------|----------|
| T Value - Prob. | -1.014538 | 0.3264 | -1.014616 | 0.3245 |
| Degrees of Freedom | | 15 | | 16.77128 |
| Diff. - Std. Error | -.6236115 | .6146752 | -.6236115 | .6146278 |
| 95% C.L. of Diff. | -1.933306 | .6860834 | -1.921304 | .6740814 |

F-ratio testing group variances 1.002458 Prob. Level 0.5053

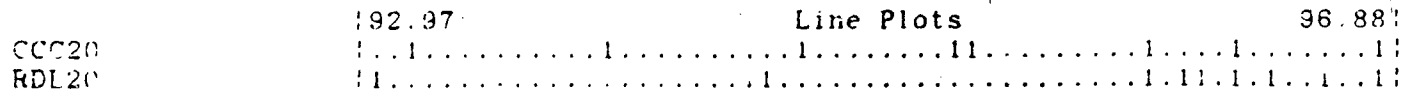
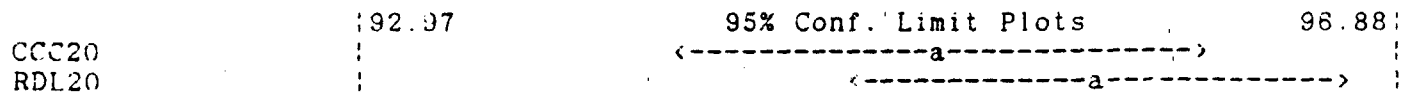

-----T-Tests-----

Date/Time 10-23-1991 07:55:08
 Data Base Name C:\solo\kydex
 Description Data base created at 07:44:32 on 10-23-1991

Two Sample T-test Results

| | RDL40 | | RDL20 | |
|---------------------|----------|----------|----------|----------|
| Count - Mean | 6 | 96.13333 | 9 | 95.79112 |
| 95% C.L. of Mean | 95.70726 | 96.5594 | 94.81882 | 96.76341 |
| Std.Dev - Std.Error | .4069726 | .1661458 | 1.265716 | .4219052 |

| | ----- Equal Variances ----- | | ----- Unequal Variances ----- | |
|---------------------------------|-----------------------------|----------|-------------------------------|----------|
| T Value - Prob. | .6337913 | 0.5372 | .7547106 | 0.4663 |
| Degrees of Freedom | | 13 | | 10.89989 |
| Diff. - Std. Error | .3422165 | .5399514 | .3422165 | .4534407 |
| 95% C.L. of Diff. | -.823664 | 1.508097 | -.6559678 | 1.340401 |
| F-ratio testing group variances | | 9.872572 | Prob. Level | 0.0115 |

| | 92.97 | 95% Conf. Limit Plots | 96.87 |
|-------|-------|-----------------------|-------|
| RDL40 | | <-----a-----> | |
| RDL20 | | <-----a-----> | |

| | 92.97 | Line Plots | 96.87 |
|-------|-------|-------------------------------|-------|
| RDL40 | |i.....21..1.....1.. | |
| RDL20 | |1.....1.....1..1..1..1.. | |

SUPPLEMENTARY

INFORMATION

CRATA

AD *A 244438*

FULL SCALE DEVELOPMENT AND INITIAL PRODUCTION OF THE
PERSONNEL/CASUALTY DECONTAMINATION SYSTEM.
SKIN DECONTAMINATION KIT (PCDS SDK)

FINAL REPORT

NOAH BORENSTEIN
PRINCIPAL INVESTIGATOR

WRITTEN BY:

B.M. ROSENBAUM
J.E. SCHULER
D.M. KEATING (PACO Pharmaceutical
Services, Inc.)
S.D. ALEMI (PACO Pharmaceutical
Services, Inc.)

NOVEMBER 1991

Supported by

U.S. ARMY MEDICAL RESEARCH AND DEVELOPMENT COMMAND
Fort Detrick, Frederick, Maryland 21702-5012

Contract No. DAMD17-87-C-7116

Rohm and Haas Company
727 Norristown Road
Spring House, Pennsylvania 19477

Approved for public release; distribution unlimited.

The findings in this report are not to be construed as an
official Department of the Army position unless so designated
by other authorized documents

C. BRATA 90A 2/24/98

REPORT DOCUMENTATION PAGE

 Form Approved
 OME No. 0704-0188

Public reporting burden for this collection of information is estimated to average 1 hour per response, including the time for reviewing instructions, searching existing data sources, gathering and maintaining the data needed, and completing and reviewing the collection of information. Send comments regarding this burden estimate or any other aspect of this collection of information, including suggestions for reducing this burden, to Washington Headquarters Services, Directorate for Information Operations and Reports, 1215 Jefferson Davis Highway, Suite 1204, Arlington, VA 22202-4302, and to the Office of Management and Budget, Paperwork Reduction Project (0704-0188), Washington, DC 20503.

| | | | | |
|--|--|--|---|--|
| 1. AGENCY USE ONLY (Leave blank) | | 2. REPORT DATE November 1991 | 3. REPORT TYPE AND DATES COVERED Final 28 APR 87 - 27 JUN 91 | |
| 4. TITLE AND SUBTITLE Full Scale Development and Initial Production of the Personnel/Casualty Decontamination System Skin Decontamination Kit (PCDS SDK) | | | 5. FUNDING NUMBERS DAMD17-87-C-7116 | |
| 6. AUTHOR(S) ROHM AND HAAS CO. B.M. Rosenbaum J.E. Schuler | | PACO PHARMACEUTICAL SERVICES D.M. Keating S.D. Alemi | | |
| 7. PERFORMING ORGANIZATION NAME(S) AND ADDRESS(ES) Rohm and Haas Company 727 Norristown Road Spring House, Pennsylvania 19477 | | | 8. PERFORMING ORGANIZATION REPORT NUMBER | |
| 9. SPONSORING/MONITORING AGENCY NAME(S) AND ADDRESS(ES) U.S. Army Medical Research & Development Command Fort Detrick Frederick, Maryland 21702-5012 | | | 10. SPONSORING/MONITORING AGENCY REPORT NUMBER | |
| 11. SUPPLEMENTARY NOTES | | | | |
| 12a. DISTRIBUTION / AVAILABILITY STATEMENT Approved for public release; distribution unlimited | | | 12b. DISTRIBUTION CODE | |
| 13. ABSTRACT (Maximum 200 words) (U) Under this contract, designated Full Scale Development and Initial Production of the Personnel/Casualty Decontamination System Skin Decontamination Kit (PCDS SDK) the Rohm and Haas Company and its subcontractor, PACO Pharmaceutical Services, Inc. focused upon improving the operational deficiencies inherent to the Prototype design skin decontamination system developed under a previous contract. In order to support the new designs, Level I drawings and specifications were prepared for the applicators, packets, soft pack pouch assemblies and also the unit of issue (box of 20 decontaminating kits). Procurement of materials, manufacturing process development and obtaining equipment/tooling were accomplished prior to kit manufacture. The FDA has determined the Personnel/Casualty Decontamination System - Skin Decontamination System - Skin Decontamination Kit (PCDS-SDK), ultimately type classified as the Decontaminating Kit, Skin: M291, to be a medical device and subject to FDA regulation as such. | | | | |
| 14. SUBJECT TERMS (U) Chemical Warfare, Medical device, Decontamination, SDK (Skin Decontamination Kit) | | | 15. NUMBER OF PAGES 107 | |
| | | | 16. PRICE CODE | |
| 17. SECURITY CLASSIFICATION OF REPORT Unclassified | 18. SECURITY CLASSIFICATION OF THIS PAGE Unclassified | 19. SECURITY CLASSIFICATION OF ABSTRACT Unclassified | 20. LIMITATION OF ABSTRACT Unlimited | |

**END
FILMED**

DATE:

4-92

DTIC