

2

NAVAL POSTGRADUATE SCHOOL

Monterey, California

AD-A242 189



DTIC
SELECTED
NOV 12 1991
S D

**SUBMARINE-INSTALLED MACHINERY MONITORING
AND DIAGNOSTICS: A STATE-OF-THE-ART REVIEW**

by

Professor Young S. Shin
LT John Robinson, USN
LT Graham Rossano, USN

Department of Mechanical Engineering

Approved for Public Release; Distribution Unlimited

This report was prepared in conjunction with research conducted and sponsored under Defense Advanced Research Projects Agency, Department of Defense. This report supersedes NPS Report 69-90-3.

91-15435



91 1118 058

NAVAL POSTGRADUATE SCHOOL
Monterey, California

Rear Admiral R. W. West, Jr.
Superintendent

Harrison Shull
Provost

This work was prepared in conjunction with research sponsored and funded by the Defense Advanced Research Project Agency, Department of Defense, Washington, D. C.

Reproduction of all or part of this report is authorized.

This report was prepared by:



Yeung S. Shin
Professor
Dept. of Mechanical Engineering

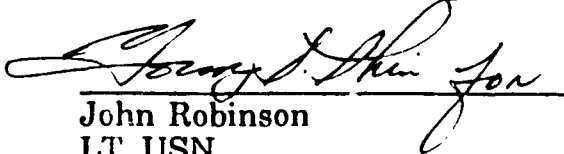

John Robinson
LT, USN

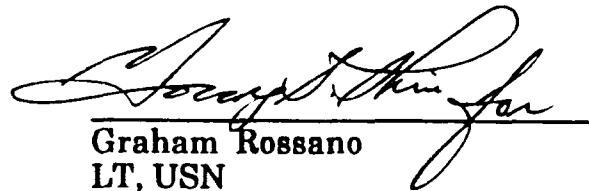

Graham Rossano
LT, USN

Recommended Approval:

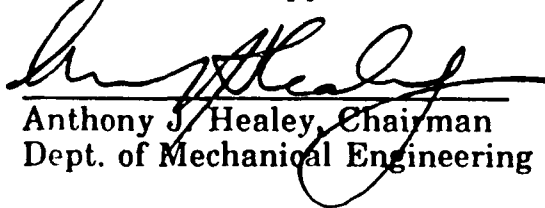

Anthony J. Healey, Chairman
Dept. of Mechanical Engineering

Approved:

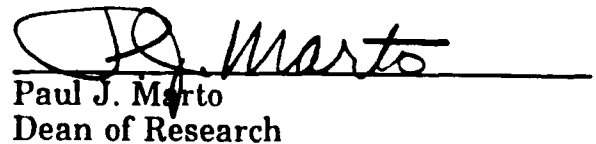

Paul J. Marto
Dean of Research

REPORT DOCUMENTATION PAGE				Form Approved OMB No 0704-0188	
1a REPORT SECURITY CLASSIFICATION UNCLASSIFIED		1b RESTRICTIVE MARKINGS			
2a SECURITY CLASSIFICATION AUTHORITY		3 DISTRIBUTION AVAILABILITY OF REPORT Approved for public release distribution is unlimited			
2b DECLASSIFICATION/DOWNGRADING SCHEDULE					
4 PERFORMING ORGANIZATION REPORT NUMBER(S) NPS-ME-91-02		5 MONITORING ORGANIZATION REPORT NUMBER(S)			
6a NAME OF PERFORMING ORGANIZATION Naval Postgraduate School		6b OFFICE SYMBOL (if applicable)	7a NAME OF MONITORING ORGANIZATION Defense Advanced Research Projects Agency, Department of Defense		
6c ADDRESS (City, State, and ZIP Code) Monterey, CA 93943-5000		7b ADDRESS (City, State, and ZIP Code) Arlington, VA 22209			
8a NAME OF FUNDING SPONSORING ORGANIZATION DARPA		8b OFFICE SYMBOL (if applicable)	9 PROCUREMENT INSTRUMENT IDENTIFICATION NUMBER		
8c ADDRESS (City, State, and ZIP Code) Arlington, VA 22209		10 SOURCE OF FUNDING NUMBERS			
		PROGRAM ELEMENT NO	PROJECT NO	TASK NO	WORK UNIT ACCESSION NO
11 TITLE (Include Security Classification) SUBMARINE-INSTALLED MACHINERY MONITORING AND DIAGNOSTICS: A STATE-OF-THE-ART REVIEW					
12 PERSONAL AUTHOR(S) Shin, Y.S., Professor, Department of Mechanical Engineering Robinson, J.D., LT, USN, and Rossano, G.W., LT, USN					
13a TYPE OF REPORT Final Report (Rev)		13b TIME COVERED FROM 01 Apr 89 TO 31 Jan 90	14 DATE OF REPORT (Year Month Day) 1991 August		15 PAGE COUNT 101
16 SUPPLEMENTARY NOTATION The view expressed in this report are those of the authors and do not reflect the official policy or position of the Department of Defense or the U.S. Government.					
17 COSATI CODES		18 SUBJECT TERMS (Continue on reverse if necessary and identify by block number)			
FIELD	GROUP	SUB-GROUP	Machinery, diagnostics, vibration, condition monitoring		
19 ABSTRACT (Continue on reverse if necessary and identify by block number) This state-of-the-art review identifies and discusses existing methods and techniques of machinery monitoring and diagnostics applicable to submarine-installed machineries, their limitations, and base-technology needs. Also included are discussions of machinery monitoring and its concept, condition monitoring and diagnostics techniques, machinery maintenance programs, vibration monitoring techniques and the current practice in U.S. Navy machinery vibration monitoring programs. The main objective is to provide the basis for research and development of future needs in this area.					
20 DISTRIBUTION AVAILABILITY OF ABSTRACT <input checked="" type="checkbox"/> UNCLASSIFIED UNLIMITED <input type="checkbox"/> SAME AS RPT <input type="checkbox"/> SPEC USERS			21 ABSTRACT SECURITY CLASSIFICATION UNCLASSIFIED		
22a NAME OF RESPONSIBLE INDIVIDUAL Dr. Y.S. Shin		22b TELEPHONE (Include Area Code) (408) 646-2568		22c OFFICE SYMBOL ME/Sq	

DECLARATION

This report supersedes NPS Report 69-90-3. Chapter V was extensively revised based on the critical comments and inputs from Mr. Alan Pride, Project Manager, Submarine Noise and Vibration Monitoring, PMS 390TN, NAVSEA.

NOTICE

The views expressed in this report are those of the authors and do not reflect the official policy or position of the Department of Defense or the U.S. Government

Accession For		
NTIS GRA&I	<input checked="" type="checkbox"/>	
DTIC TAB	<input type="checkbox"/>	
Unannounced	<input type="checkbox"/>	
Justification		
By		
Distribution/		
Availability Codes		
Dist. Special		
A-1		



TABLE OF CONTENTS

	<u>Page</u>
ABSTRACT.....	I-1
I. INTRODUCTION	I-1
II. MACHINERY CONDITION MONITORING.....	II-1
A. Basic Concepts of Maintenance.....	II-1
B. Machinery Maintenance Programs.....	II-2
1. Crisis Maintenance.....	II-3
2. Preventive Maintenance.....	II-4
3. Predictive Maintenance.....	II-4
C. Condition Monitoring.....	II-5
1. Fault Detection and Diagnostics.....	II-7
2. Status of Condition Monitoring.....	II-8
3. Types of Condition Monitoring Programs.....	II-9
III. CONDITION MONITORING METHODS AND TECHNIQUES.....	III-1
A. Monitoring Methods.....	III-1
1. Combining Monitoring Methods.....	III-3
2. Condition Monitoring Outputs.....	III-4
B. Traditional Monitoring Techniques.....	III-6
1. Temperature Measurements.....	III-8
2. Pressure Measurements.....	III-11
3. Thrust Measurements.....	III-12
4. Current Monitoring.....	III-13
5. Acoustic Emission Transducers.....	III-14
C. Wear Based Monitoring.....	III-15
1. Introduction.....	III-16
2. Lubricant Sample Analysis.....	III-19
3. Collection/Trapping Methods.....	III-20
4. In-Line Method.....	III-20
5. Chemical Microsensors.....	III-21
6. Surface Layer Activation.....	III-24
D. Summary.....	III-25

TABLE OF CONTENTS

	<u>Page</u>
IV. VIBRATION MONITORING TECHNIQUES.	IV-1
A. General	IV-1
B. Early Vibration Monitoring Techniques	IV-4
C. Frequency Domain Analysis	IV-6
D. Time Synchronous Averaging	IV-14
E. Quefrequency Domain - Cepstral Analysis	IV-16
F. Amplitude Probability Density Function	IV-19
H. Shock Pulse Measurements	IV-20
V. NAVAL MACHINERY CONDITION MONITORING AND DIAGNOSTICS: A REVIEW OF AVAILABLE LITERATURE	
A. General	V-1
B. Naval Vibration Monitoring Program	V-2
C. Similarities within the two programs	V-3
D. Differences between the Two Programs	V-5
E. Discussions	V-7
F. Recommendations	V-8
VI. CONCLUDING REMARKS	VI-1
A. Summary	
B. Future Research Areas	

ACKNOWLEDGEMENTS

RERERENCES

BIBLIOGRAPHY

SUBMARINE-INSTALLED MACHINERY MONITORING AND DIAGNOSTICS: A STATE-OF-THE-ART REVIEW

by

Y. S. Shin, J. D. Robinson, and G. Rossano

ABSTRACT

This state-of-the-art review identifies and discusses existing methods and techniques of machinery monitoring and diagnostics applicable to submarine-installed machineries, their limitations, and base-technology needs. Also included are discussions of machinery monitoring and its concept, condition monitoring and diagnostics techniques, machinery maintenance programs, typical machinery elements and their characteristics, vibration monitoring techniques and the current practice in U.S. Navy machinery vibration monitoring programs. The main objectives are to evaluate the current practice in submarine-installed machinery monitoring and diagnostics and to provide the basis for research and development of future needs in this area.

I. INTRODUCTION

As a part of "Submarine-installed Machinery Noise, Monitoring and Diagnostics" research program sponsored by Defense Advanced Research Projects Agency(DARPA), this state-of-the-art review identifies and discusses existing methods and techniques of machinery monitoring and diagnostics applicable to submarine-installed machineries, their limitations, and base-technology needs. Also included are discussions of machinery monitoring and its concept, condition monitoring and diagnostics techniques, machinery maintenance programs, typical machinery elements and their characteristics, vibration monitoring

The various components of all machineries have finite lives and are always subject to failure. A need to accurately assess submarine-installed machinery condition is essential to prevent unexpected catastrophic failures causing critical problems in the operation of naval vessels. The vibration and noise generated by the machines are commonly used to reveal its machinery condition. The goals of monitoring and diagnostics include: detecting faults in machine operation at inception or well in advance of failure, identifying the cause of the fault, and anticipating breakdown in machine operation.

The research that was performed in this state-of-the-art review consisted of an in-depth review of literature available to the general public. A majority of this literature was published over the last eight years and, although not exhaustive, is believed to be representative of the technologies currently being used in condition monitoring. This report also includes a discussion of current Navy programs used in both surface ship and submarine communities for machinery condition monitoring and diagnostics. It should be recognized that no review of this type can examine every aspect of the subject, however it is the authors' belief that this report presents a concise and informative picture of the state-of-the-art in machinery condition monitoring and diagnostics.

The goals of the state-of-the-art review are,

- to establish a concise concept of condition monitoring
- to review condition monitoring programs used by the Navy and in civilian industry
- to identify the variety of technologies useful in condition monitoring of basic machinery elements
- to describe monitoring techniques used in condition monitoring
- to provide the foundation of knowledge useful for future research and development work
- to identify the areas for future research and development work
- to produce a useable document to serve as a guide on condition monitoring

II. MACHINERY CONDITION MONITORING

A. Basic Concepts of Maintenance

The maintenance of machinery has long been recognized as a major portion of operating costs. Minor improvements to maintenance programs have the potential to produce large cost savings. These improvements can also lead to increases in safety, availability, and efficiency. A detailed description of maintenance programs is not the subject of this report, but it is important to introduce a few basic concepts to serve as a foundation of machinery maintenance practices and to act as a lead in for the concept of condition monitoring.

The term, "maintenance" will be used as a description of the process involved in correcting a fault in a machine. The performance of a complete overhaul of a pump, which includes replacing bearings and balancing the impeller, is obviously maintenance. However, actions quite different in scope, such as lubricating bearings or replenishing oil in a sump, is also a form of maintenance. Another concept the reader should be familiar with is illustrated in Figure II-1. This figure depicts what is commonly called a 'bath-tub curve' or 'product failure rate'.

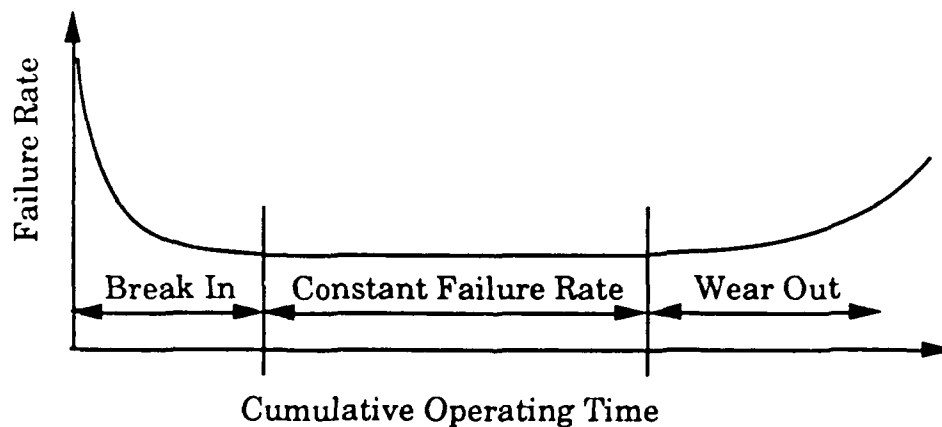

Figure II-1. Product Failure Rate, "Bathtub Curve"

This curve is used to graphically depict the failure process that the machinery components experience during a normal lifetime. The vertical axis of the curve is the failure rate and the horizontal axis is a time scale representing cumulative operating time. The left hand side of the curve is representative of failures that occur to new components and is called the break-in portion of the curve. The middle flat part of the curve represents the normal useful life of a component, and the right hand side of the curve represents the increase in failure rate after the component has exceeded its normal useful life. The use of this curve to depict the life of a component or machine is very common in the literature. The bath-tub curve of identical components may be quite different depending on several factors. For example, a quality assurance program can remove many of the components that might normally experience a short lifetime, this would cause a change to the left side of the curve for a component. Similarly the improper lubrication of a component would affect the width of the flat portion of curve, and greatly increase the slope of the right hand side of the curve. This would indicate that the component would have a shorter useful life. Calculation of the failure rate curve for an individual component or machine is rarely done, but the concept of the curve will give a better appreciation of the various maintenance programs that have been developed and the development of condition monitoring.

B. Machinery Maintenance Programs

The machinery maintenance programs can be grouped into three broad categories: [1]

- crises maintenance
- preventive maintenance
- predictive maintenance

Each of these programs will be discussed separately, but the reader should be aware that, in practice, aspects of all three programs can be found in an actual program. The above classification is a method to conveniently group the programs in order to clearly describe methodology and present specific

features particular to a method. The sketch of overall maintenance programs are shown in Figure II-2. Much of the information used in these descriptions was adapted from [Ref. 2].

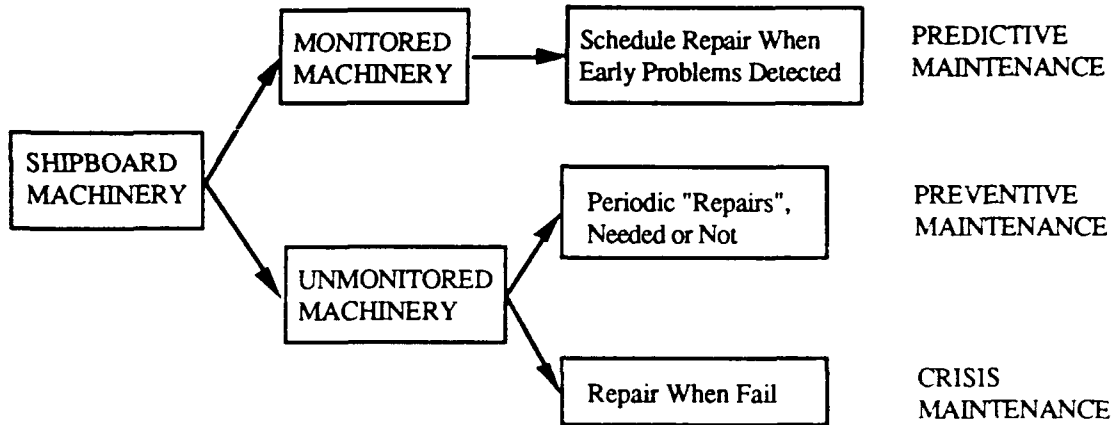

Figure II-2. Overall Machinery Maintenance Programs [Ref. 1]

1. Crisis Maintenance

The lowest level program is popularly referred to as a crisis maintenance program. This is one where no specific monitoring, performance evaluation, condition evaluation, or maintenance routine exists. Such a program relies strictly upon observations which may be made by the operators for gaining any forewarning of trouble, with the result that machines and/or their components all too often degrade to a state of being unfit for service before any maintenance or repair efforts are undertaken. Note that this is not a criticism of the performance of operating engineers, but rather a statement on the general inadequacy of the untrained human senses to detect machinery degradation at a sufficiently early stage to prevent serious problems, as well as a statement on how rapidly some machinery faults may develop and grow to unacceptable limits.

2. Preventive Maintenance

The next program level is that of the preventive maintenance program in which maintenance is carried out on a regular schedule which is based upon a specified time interval, a specified number of operating hours, or some other measure of machinery operating life. An example of this would be automotive maintenance schedules which typically specify a limiting number of months or miles driven between maintenance work. This is certainly an improvement on the previous level, but the quality of this type of program relies upon the ability to accurately determine the optimal interval(s), and it presumes that all machines of the same class (thus assigned the same intervals) will degrade comparably in fashion, rate, and amount. As accurate as they may be, the assigned intervals, at best, can reflect only statistically averaged measures of what have proven to be acceptable intervals. In order to avoid serious outages, these intervals may be conservative and frequently result in wasted time, money, and effort in servicing those units which are performing above the average. In short, the intervals will only be optimal for those units which degrade exactly as does the average unit of the class. Those which perform below average may fail before the maintenance is done as well as cause premature development of faults in related components; those which perform above average receive unnecessary maintenance and also invites the added risk that their condition may actually be worsened by the maintenance, especially if it involves opening of the unit and/or routine replacement of components. There is also the consideration that, to be cost effective, such a program must be limited to addressing a finite number of the higher probability faults which has the effect that the program may essentially be blind to many problems that can lead to chronic trouble and repetition of work that only treats the symptoms.

3. Predictive Maintenance

The final level is that of the predictive maintenance program in which, as the name implies, machinery faults are detected at the early stages of their development so that maintenance needs are able to be predicted, with the result that maintenance is performed only when it is needed and only on those components which need it. As discussed and shown in Figure II-1, the "bathtub curve" displays how wear rate varies

with time for most machinery components. Time-based preventive maintenance programs may interrupt the service life of a component which may still be in its normal wear rate period, whereas predictive maintenance program will only remove a unit for maintenance when it is in its final stage of serviceable life, i.e. somewhere in the increasing wear rate portion of the curve. Close monitoring and experience can provide very good estimates of projected time to failure which allows the programs to realize optimal maintenance intervals on a machine-specific basis.

Although predictive maintenance programs can not assure that an unexpected failure will not occur, they can and do successfully avoid unnecessary maintenance work and expense. Additional benefits of these programs include increased productivity due to longer operating time between repairs, reduced spare parts inventories and reduced repair times since the exact components in need of repair or replacement are identified long before the work is commenced, and the ability for advanced planning and scheduling of service interruptions rather than their unannounced arrival which is an attendant problem of the other program types.

C. Condition Monitoring

The technique used in a predictive maintenance program to detect and diagnose a fault is called "condition monitoring". The term condition monitoring is not universal in the literature, but is the most descriptive and least awkward of the many terms used. Goals for a condition monitoring program are:

- to provide clear warning of trouble at earliest possible time
- to reduce needless overhauls by knowledge of machines' state
- to reduce maintenance actions
- to reduce spare parts inventories

It is emphasized that predictive maintenance programs cannot prevent all failures from occurring, but unnecessary maintenance work and expense can be reduced with a properly designed system. These goals of condition monitoring are achieved by utilizing a system that:

- requires the minimum capital investment
- is robust and trouble free
- is capable of being used at the lowest competent level

Mathew [3] classified the vast number of techniques for monitoring machinery condition into six categories:

- Aural Monitoring
- Visual Monitoring
- Operational Variable Monitoring
- Temperature Monitoring
- Wear Debris Monitoring (Tribology)
- Vibration Monitoring

The first four areas can be viewed as traditional methods that operators and maintenance personnel have used for many years to evaluate the condition of machinery. However, increasing technology is providing additional methods of analysis that lie within these traditional categories; borescope, thermograph, acoustic monitoring, and infrared imaging are examples of just a few new methods to monitor machinery. Wear debris analysis, or tribology, deals with the measurement and classification of the wear material produced by components. In condition monitoring, vibration monitoring is by far the most widely written about and used of these six techniques. These methods are discussed in greater detail later in this report. Utilizing these technologies enables maintenance personnel to establish the condition of machinery and components.

1. Fault Detection and Diagnostics

The use of these techniques to monitor the condition of machinery is called "fault detection and diagnostics". Figure II-3 illustrates the process.

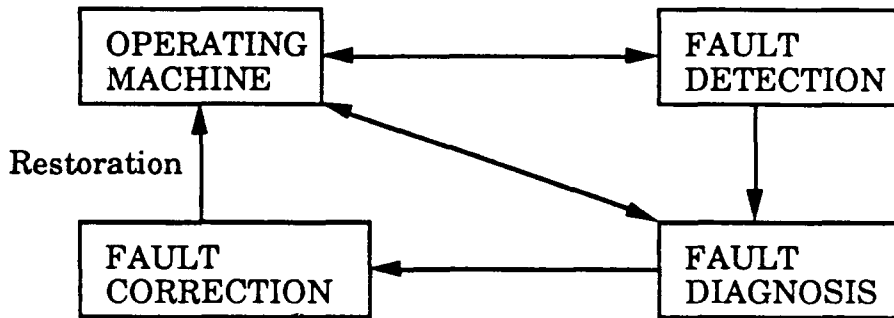

Figure II-3. Fault Detection and Diagnostics Process

The upper left hand block represents operating machinery. The fault detection block represents a process used to detect a fault in the machine. This monitoring may be as simple as monitoring operating parameters such as lube oil pressure or temperature, or it could be more elaborate and use a combination of methods. The double arrow between the upper two blocks indicates that fault detection may lead to a modification of the machinery's operating condition, such as securing the machine. When a fault is detected the fault diagnosis process begins.

Fault diagnosis involves the process of trouble shooting the machinery to determine the cause of an alarm produced by the detection process. The diagnostic process may utilize data collected in fault detection, but this is not necessary. Normally the diagnostics process involves obtaining more data from the machine. This process has several steps:

- determine if a fault is valid or a false alarm
- determine the nature of the fault
- determine the severity of the fault
- determine the optimum method for correction

Once the fault has been identified it must be determined whether the machine can be left in its current operating status or if the machine should not remain operating. Therefore a decision on how and when to restore the machine to a desired operating condition is made. Overhauling the machinery may be required, or making a simple repair such as lubricating a component may be sufficient to keep the machinery operating at a level which does not affect the readiness of the unit. The lower left hand block of the diagram represents the action taken. When the decision on maintenance action is made the machine is restored to an operating condition and the process continues. It is emphasized that maintenance actions do not have to be performed just because a fault is detected. Machinery components do experience wear and components do naturally reach an end to useful life. A well designed system that can provide information to, or make the decision for, maintenance personnel as to the severity of a fault and predict the remaining life is the goal of a predictive maintenance program. A good example of a system designed to warn the user of limited remaining useful life is the automobile tire which has a tread wear indication pattern which indicates when the tire should be replaced.

2. Status of Condition Monitoring

In the mid 1970's conventional preventive maintenance programs were yielding to predictive maintenance theories and practices. Much of the literature of this period reflects a general optimism that condition monitoring was to be the great maintenance tool to reduce operational costs. Significant research was being conducted to investigate methods to perform condition monitoring. However, over the last several years a lull in condition monitoring research has occurred. Stewart [4] notes two reasons for this:

- over-optimism on part of proponents of condition monitoring
- industry not ready for condition monitoring

A third reason could be added:

- condition monitoring not ready for industry

The first reason is simple to understand, initially the use of condition monitoring had significant success in reducing maintenance costs even using very crude techniques. The early maintenance programs were very cost effective and the initial cost of equipment was recovered within several months. Success with the early methods lead to attempts at more automated systems and thus began the second reason. The automated systems which had been developed were extremely dependent on data processing capabilities. For many industries it was difficult to justify the costs of these systems for only maintenance, especially when the 'cruder' methods where still successful. The third cause of the lull can be attributed to the companies producing the systems. Many of the products to support condition monitoring processes were simply of little value. The systems were not based on experimental investigations or even great amounts of experience with the simple techniques. The literature published during the last few years indicates that this is still occurring but, it is refreshing to note, that a growing number of papers are appearing which are critical of the current state of commercial monitoring programs.

3. Types of Condition Monitoring Programs

Condition monitoring programs are grouped into three levels:

- manual monitoring programs
- semi-automatic monitoring programs
- automatic monitoring programs

The key difference between these groups is the level of operator interface needed to run the program.

3.a. Manual Monitoring

Much of the background information for manual monitoring is well described in References [5-8]. In these systems data is collected and analyzed manually by maintenance personnel. Hand held portable instrumentation and basic sensors are used to collect data, maintenance

personnel analyze this data with a variety of techniques and decisions are made on the condition of the machinery. The system requires maintenance personnel who are well trained and who have developed significant amounts of experience. The maintenance personnel's knowledge and experience are used to detect faults and diagnose the possible cause. A manual monitoring system is dependent on the maintenance personnel. Collecting, analyzing, and storing the data from monitored machinery can be a management nightmare. The necessity of motivated maintenance personnel cannot be ignored. In the process of conducting research of these programs, several plant engineers told stories of how they found condition monitoring equipment purchased by predecessors still in the original shipping containers. However, if the system is well implemented and supported by the operators it can be very successful, showing return on the investment in equipment and training in less than 12 months.

Manual monitoring systems generally rely on periodic vibration monitoring of specific selected machinery. A typical system will measure an overall vibration level of each machine and by comparing the recent data to earlier data maintenance personnel can establish a general condition of a machine. If this measurement indicates some type of problem which may be developing, the maintenance personnel would make a more detailed measurement and use a technique such as frequency analysis. This measurement would provide a much better indication of the machinery condition and would enable the maintenance personnel to make a recommendation as to the required level of maintenance. Wear debris analysis of lubricating oils is another technology that is often utilized in a manual monitoring system. The use of other monitoring techniques would be dependent on the motivation of the maintenance personnel, but generally a lack of time precludes their utilization.

Manual monitoring systems are generally used with well established preventive maintenance systems. The periodic nature of the vibration monitoring lends itself to becoming a periodic check within the preventive system. The combination of these two systems, manual monitoring and preventive maintenance, can produce a maintenance system that is very effective, but susceptible to changes in the maintenance

force. An additional problem is that only simple machinery can be effectively monitored. Complex systems consisting of several machines cannot be monitored as a system because of the limited data analysis capabilities of the maintenance personnel.

3.b. Semi-Automatic systems

Much of the information for this section's background is adapted based on References [4,9,10]. The semi-automatic system is very similar to the manual system with the exception that data processing capabilities, normally a desk top computer, is added to assist in the storage, presentation, and analysis of the data. The maintenance personnel are still required to gather data, but the computer can manipulate a larger amount of data more efficiently. There are numerous programs on the market which have been well received by industry and many of the programs have simple analysis capabilities to alert the maintenance personnel to conditions that may warrant additional attention.

In general these computer programs emulate the procedures established in a manual monitoring system. The general nature of the computer allows the data to be handled more efficiently and allows additional data to be collected and analyzed in order to establish a better picture of the state of a machine. The major advantage of this type of system is that more data can be utilized. Additional techniques using operational variables and temperature analysis can be added to the condition monitoring process. Maintenance personnel experienced with the monitored machinery and able to use the monitoring program can produce a predictive maintenance system that is very capable. However this type of system, like the manual monitoring system, is very susceptible to maintenance personnel turnover and the ability to monitor complex systems is limited.

3.c. Automatic Systems

The next logical extension of monitoring systems is the fully automated monitoring system. This system consists of a completely hard wired monitoring system along with automated data processing

capabilities for the collection, presentation, and storage of the data. Fully automated systems do exist but these systems are very simple in overall capabilities in that only certain parameters are continuously monitored. The systems will perform a preset function when this monitored parameter exceeds (normally) a predetermined level. Reference [11] has a well written description of this type of automated system in use at the Paducah Gaseous Diffusion Plant. The system continuously monitors the plant and when an alarm condition is sensed the system warns maintenance personnel. The maintenance personnel then take portable equipment to the machinery for in-depth diagnostics. In order to reduce the reliance on the maintenance staff a higher level of automated system is needed. This type of higher level automated system is generally called an expert system.

Reason [12] defines an expert system as "electronic processors that use knowledge and inference procedures to solve problems which normally require human expertise." Reason points out that most of the current systems with expert capabilities are interactive structures that instead of providing definitive answers only provide a probable cause for a problem. In 1987, Reason [12] states that expert systems were about five years away. More recent statements by Lyon [13] appear to indicate that this was probably a conservative estimate.

The literature indicates that an expert system should be expected to:

- gather data
- analyze the data for detection of faults
- perform diagnosis for faults detected
- predict remaining life for failing components
- make or recommend maintenance actions

Automating data collection is possible at this time, but much improvement can be made. The first aspect of collecting data involves the selection of transducers. Sensors used for condition monitoring should be low cost, high reliability, and immune to harsh environmental conditions.

Current technological capabilities make these requirements difficult to achieve.

Other improvements needed in this area include the medium used to transfer the electrical signal from the transducer to the processing equipment. Fibre optic cables are one option in that they eliminate the weight of standard cables and improve the quality of measured signals. Equipment specifically designed for condition monitoring systems will improve the data collection process. Machinery casings can be designed to permit transducers to be easily mounted and ports for probes should be a part of a system designed to be supported by condition monitoring. A final area where improvement can be made is in the use of data buses to transfer data from transducers to a central processor, or even from local processors to a central processor.

Fault detection is considered to be the key to the condition monitoring process. Detection of a fault as early as possible allows more accurate diagnostics to be performed. One of the problem areas shown in the literature is the use of monitoring techniques as both detection and diagnostics processes. Use of these methods in this manner is wasteful of time and data processing capabilities. More effective monitoring could be accomplished by developing detection techniques that are used to monitor the machine for a change in state and then using a more detailed diagnostic process when a change in state is detected. Reference [5] points out that the fault detection processes should detect a majority of faults as early as possible, give few false alarms, and provide sufficient information to enable a decision to be made as to when diagnostics is required. Performing diagnostics is the most well developed portion of the requirements for an effective expert system and will not be discussed in this chapter. It is important to note that the detection process can be made much more effective by combining monitoring methods and using all of the collected data together.

The final two areas separate expert systems from basic automated systems. These areas require much more research, but cannot be fully developed until the first three areas have been well established.

Further discussion of these areas will be made in the final chapters of this report, but from the discussion already presented the advantages and disadvantages of an expert system are clear. The advantages of such a system are:

- reduction in manpower required to monitor a system
- better knowledge of equipment
- reduction in maintenance costs
- increased readiness

Disadvantages of expert systems are:

- cost
- significant ADP capabilities required
- significant research needed to develop

The disadvantages make expert systems neither desirable nor cost effective for monitoring most machinery installed aboard a ship. Machineries that such a system would be justified for are [14]:

- critical for production (or readiness)
- extremely costly to replace
- related to safety

With these limitations, automatic monitoring systems appear to be justified for weapons systems and propulsion systems. Increasingly complex systems and decreasing human resources make development of effective expert systems for these types of equipment important. An additional requirement for efficient, reliable, and rapid monitoring of weapon and propulsion systems should be incorporated since future battles which are anticipated to last only minutes. Stewart [15] presents a logical, straight forward method to develop expert systems:

- conduct a design audit
- prove the technologies selected
- implement the technology

The first step establishes a thorough understanding of the system. Stewart listed several areas that should be included in this investigation:

- construction of the machinery system
- previous and expected failure modes
- economics of system unavailability
- detectable faults
- operating environment

The final result of this design audit process is the establishment of an experimental 'approach' at monitoring the system. This 'approach' is molded into a prototype system in the second level of development. The second step, proving the technology, requires through in-depth testing of the machinery in the environment in which it will be operating. The main objective of this level is to demonstrate the capabilities of the monitoring system and establish the system's cost effectiveness. Additional research on condition monitoring techniques may be needed in order to correct problems encountered during testing or to replace techniques that are not cost effective or that prove to be inefficient in condition monitoring.

The third step consists of converting the prototype into an operational system. This step occurs only after completion of the second level. If the first two steps are not accomplished before implementing the technology a mismatch between the requirements needed and the system obtained will probably result. It should not be misinterpreted that this three step process forces the system designers to start with a blank sheet. There are areas in which condition monitoring is a well established procedure, the gas turbine industry is an excellent example. However, for any given system it is not possible to get a generic off-the-shelf expert system. Some monitoring technologies exist, but better methods that can provide more efficient systems need to be developed. The designer must make rational decisions as to what techniques are best suited for specific machinery and

produce a system that utilizes these technologies to the fullest extent. This can only be accomplished with research and experimental tests on actual equipment.

III. CONDITION MONITORING METHODS AND TECHNIQUES

A. Monitoring Methods

The broadly classified six condition monitoring techniques were presented in Chapter II and also shown in Figure III-1. These techniques were aural monitoring, visual monitoring, operational variable monitoring, temperature monitoring, wear debris monitoring, and vibration monitoring.

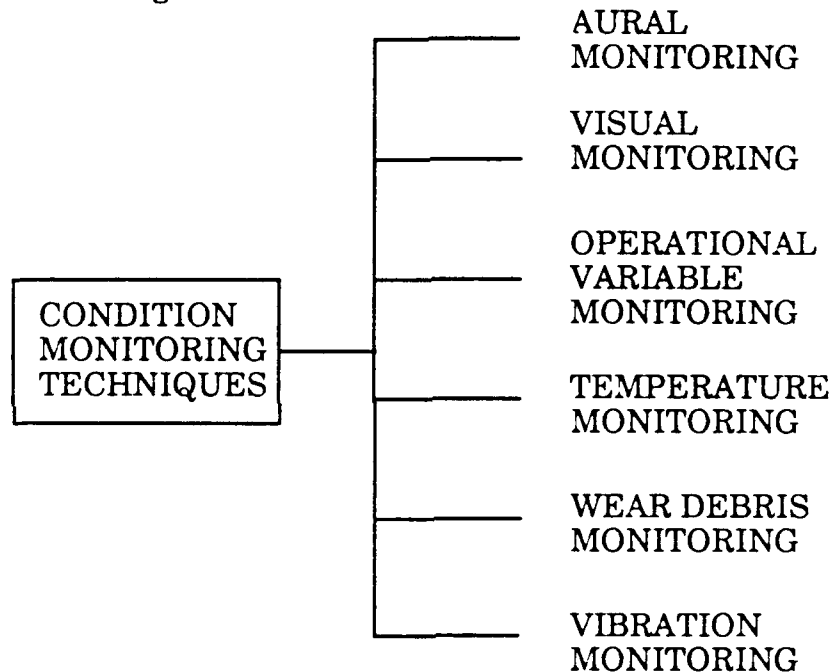

Figure III-1. Condition Monitoring Techniques [from Ref. 3]

These six categories can be regrouped in a more logical manner. The first four methods can be grouped as traditional monitoring techniques. Wear debris monitoring is rather unique in its method and can be renamed as lubricant and wear debris monitoring. Vibration monitoring is also unique and shall be left as a category by itself. With these changes, the condition monitoring techniques are recategorized into three groups as shown in Figure III-2.

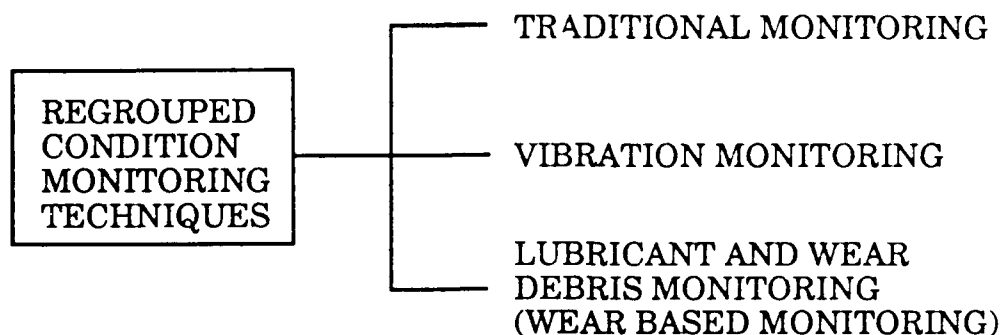

Figure III-2. Regrouped Condition Monitoring Techniques

The final category will be abbreviated as wear based monitoring in the remainder of this report. In examining the use of these methods in the literature one aspect stood out clearly and that is that there is a fundamental difference in the manner in which data is used between traditional and wear based monitoring methods and vibration monitoring methods. This difference is significant.

Traditional and wear based monitoring methods typically utilize the raw data measured from transducers or test results in a direct manner. For example, in a traditional monitoring technique, pressure transducers are a very common device. The measured output from the pressure transducer is generally used with little modification. Similarly in a wear based monitoring technique, a lubricant sample is drawn and tests are performed on it. The results are used directly in a monitoring scheme.

The vibration monitoring technique does not use the vibration signal directly. This technique usually filters the signal and manipulates it analytically. The result is utilized in a number of different ways, all of which provide different information about the condition of the equipment that is being monitored. Vibration monitoring has been popular for several decades and has improved a great deal.

Traditional monitoring and wear based monitoring will be described in this chapter, while vibration monitoring will be presented in the following chapter separately in order to fully represent the wide variety of

methods used. For the traditional and wear based methods a more abbreviated description will be presented, this treatment reflects the emphasis found in the literature to these approaches. This should not be taken as a statement on the quality of information that can be gained, or as a statement on the usefulness of the methods themselves. To the contrary, it should be looked at as an indication of how under-utilized these monitoring methods are in condition monitoring.

In addition to the discussion of traditional and wear based monitoring, several individual monitoring techniques that were found in the literature will be described in order to allow the reader to gain an appreciation of some of the innovative concepts that were found in these areas. In depth analysis of every technique being used is, of course, impossible. It appears that methods available for monitoring machinery systems are unlimited. The methods used in monitoring a specific system will be a reflection of the background, experience, imagination, and thoroughness of the designers.

1. Combining Monitoring Methods

Numerous references point out that, when properly utilized, the combination of several monitoring techniques results in a condition monitoring scheme that is much more effective than any one of the techniques used independently. In the literature there was some work presented that offered basic models attempting to tie together several of these monitoring techniques. For example, Cempel [16] describes a modeling concept that utilizes an in-depth analysis of the relation between the vibration of a machine and the wear that will occur. He terms this type of analysis a tribovibroacoustical model. This approach though, was not widely seen in the literature. Instead most researchers seemed content to present monitoring methods that were developed to solve immediate problems, or were being investigated simply because it could be performed easily and shown to have usefulness in condition monitoring. Very little background material was provided that attempted to justify the use of a specific technique in a particular system or to evaluate the ability of the technique to be used in the field. Additionally, there appears to be very little

concern given for the amount of data processing equipment and memory needed for some methods or for the amount of electronic support equipment needed in the manipulation of electronic signals. Use of an an in-depth examination of a machinery system, like that presented by Cempel, should provide the direction for the development (or use) of monitoring techniques that lie within and across the boundaries of the monitoring methods presented. The wheel does not have to be reinvented in this process, but the development of a monitoring system should not be looked upon as an after-thought in the design of a system. In addition, the design of a monitoring system for already existing equipment should not be seen as impossible, but it should be realized that the resulting monitoring scheme will not be as efficient as a monitoring system developed in the design of a system.

2. Condition Monitoring Outputs

Monitoring techniques do not have to be complex to be effective. When evaluating the different methods used to monitor the systems, it is important to have an understanding of the output from the different monitoring techniques and the different approaches to use this output. Stewart [4] has divided the utilization of the output into three different categories:

- response characteristics
- feature tracking
- pattern recognition

The first category is more of a concept than something physical. Stewart points out that the output from monitoring techniques should be looked at from the aspect of dynamic models of the machinery system. These outputs can be thought of as experimentally determined values that represent certain characteristics of the system. An example of this would be the familiar pressure-enthalpy (P-h) diagrams used in thermodynamic models of the operation of systems such as refrigeration. One instrument can not give a full representation of the process a refrigeration system is undergoing. However, combining the output of instrumentation allows a P-v diagram to be produced, and a measurement

of the operation of the system can be produced. This measurement can be used for comparison with a P-v diagram derived from system models and permits an evaluation of the condition of the machinery. The obvious disadvantage of this type of approach is the difficulty in developing experimental based models for comparison.

The second category of output is called feature tracking. This approach, in general, ignores the use of models and instead utilizes the measurements of parameters and the trends of these parameters. The trends are used to indicate the condition of the machinery and a level of usefulness remaining in the component is established. Hadden and Maurer [17] indicate the difficulties in the use of trending methods. The natural tendency is to use linear trending of measured variables to predict remaining life. In this paper the authors indicate that the measured parameter often accelerates with increasing deterioration making linear trending ineffective and even deceptive. Data storage is another significant drawback of this method. When significant numbers of machineries are being tracked along with many parameters, the storage capabilities of a small automated data processing system are quickly overloaded. In addition, the data handling routines can become significant leading to both complex computer codes and growing numbers of maintenance personnel needed for handling data processing related duties.

The third category, pattern recognition, sometimes utilizes a simple form of modeling, but the models are often not detailed. Instead, the approach relies on matching measured data to the known, or previously experienced, fault conditions. This methodology invariably leads to detection of faults that have not been cataloged and reliance on specialized pattern recognition codes that can be lengthy and difficult to modify.

Designers should be aware of these concepts when involved in the design process or when examining monitoring techniques for the selection to particular applications.

B. Traditional Monitoring Techniques

Traditional monitoring techniques have probably been in use ever since the first machine failed unexpectedly. In this research, traditional monitoring techniques are best described as those methods that utilize parameters that have traditionally been used in the monitoring of machineries. Anyone involved in machinery maintenance knows of cases when senior maintenance personnel could predict when a piece of machinery would fail by listening to it or by feeling a bearing casing. This is one means of "traditional" monitoring. Another method, used in the Navy, is the recording of operating parameters. This data is religiously recorded but often very little is done with it other than a cursory review by senior maintenance personnel.

Traditional monitoring techniques include the use of operating parameters such as temperature, pressure, speed of operation, and many other aspects of machinery operation. Table III-1 has been developed from the literature in order to illustrate the many aspects of machinery operation that can be utilized in condition monitoring.

Table III-1. Measurable Operating Parameters

Visual Appearance	Component Dimensions	Weight
Component Position	Electrical resistance	Tension
Time Interval	Electromagnetic Emission	Voltage
Operating Speed	Current Demand	Thrust
Power Demand	Torque Generated	pH
Temperature Level	Temperature Difference	Current Pattern
Internal Flow Rate	External Flow Rate	Density
Displacement	Speed/Velocity	Fluid Level
Angular Displacement	Angular Acceleration	Solid Level
Force	Depth or Thickness	Viscosity
Sound Level	Pressure	Humidity
Differential Pressure		

In the review of the literature, it was found that very little experimental research for new methods to use these parameters was being conducted. It is natural to ask why. One reason might be that methods to

utilize these parameters are so well developed that little research is needed to improve upon them. A second reason could be that prior research has determined the methods are of so little value that further research is not warranted. The probable reason lies somewhere between these two extremes. Stewart [15] points out that, in the past, measurements that could be made on the equipment were controlled by the available technology. Methods of monitoring some aspects of the operation of machinery system simply were not available. Because of this limitation techniques that were available were used and methods such as vibration came to be relied upon as they became more familiar to maintenance designers. In-depth modeling, though possible, was not practical because results could not be implemented. However, the rapidly expanding development of piezoelectric transducer technology and support microelectronics has changed this. Significant research for methods using the traditional parameters should be conducted but is not being performed due to the familiarity with established techniques and their relative success.

The literature is not barren of research, but shows a lack of innovation. Much of the literature deals with monitoring of steady state parameters, with analysis consisting of a form of trending to evaluate the condition of the machinery. Several papers point out that this method of analysis is often of little value due to the ruggedness inherent in most machinery design. Significant changes in a steady state operating parameter often occur only after significant damage has already occurred to the machinery. For example, Stronach et al. [18] note that in reciprocating refrigeration compressors it has been found that even with 50% of the machine's valves seriously damaged little change in the monitored flow parameters was observed. There is no doubt that this is an extreme case, and proponents of this approach to monitoring could provide examples of situations where traditional methods have been used successfully, but the literature simply does not indicate this is the current situation. In addition, discussions with Naval personnel involved in surface ship condition monitoring indicate that analysis of the data collected using traditional operating parameters has been virtually abandoned.

It is interesting to note that much of the innovative material that is being produced in this area is coming from nuclear power industry research and from research on reciprocating machinery. As nuclear plants are aging and new construction has 'slowed', new methods of monitoring for failure are needed. Utilization of the existing instrumentation in innovative methods appears to be a driving factor in the development of new techniques. Reciprocating machinery, on the other hand, produces quite complex vibration signals that are difficult to analyze using standard vibration monitoring techniques. This forced the vibration approach to be somewhat abandoned as better methods were searched for in monitoring of this machinery. To allow the reader to gain an impression of some of these innovative approaches, the results of a review of several interesting papers found in the literature will be briefly presented.

1. Temperature Measurements

Several references found in the literature indicated that temperature measurements may not be as useful in diagnosing machinery faults as might be expected. The major reason for this seems to be that in many instances the temperature of a damaged component will be affected only after a significant level of damage has occurred. Once this level of damage is reached, the heat caused by excessive friction is portrayed as a change in temperature.

This type of example is described in Reference [19]. The experimental research described in this paper involved a comparison of the effectiveness of several monitoring techniques for the detection of bearing faults produced by fatigue failure. In the experiment it was found that use of the temperature of the bearings was not effective in detection of bearing damage. Several other methods of detection, vibration and wear debris monitoring, indicated the occurrence of faults long before a significant change in bearing temperature occurred.

Stronach et al. [18] present a different aspect of temperature monitoring. In this research the use of temperatures proved very useful when working with test rigs for use on reciprocating gas compressors

installed on off-shore drilling platforms. Damage to compressor cylinders was indicated when temperatures of the working fluid had risen.

The difference between the two studies lies in the use of the temperature measurements. In the first case the bearing lubrication temperatures were monitored and, until a significant amount of damage had occurred, no faults were detected. In the second case, temperature changes occurring in the working fluid were monitored and a change in the gas temperatures from normal conditions indicated that a defect existed. A cause for the changed temperature was then traced to the damaged cylinder. There is a difference between the two approaches and the second example emphasizes the need to understand the system being monitored and the changes that can occur by faults.

Gulyas' paper [20] is an interesting one that illustrates another use of temperature as a monitoring method and the emphasis on understanding the system being monitored. The paper deals with research performed on a commercial gear drive. This research describes a method of measuring temperature distribution of the machinery casing of a gear drive and correlating it to the power loss across the gears in the drive. Figure III-3 illustrates the gear drive and how temperature measurements were made.

The gear drive casing was divided into seven cross-sections with each cross section having six different temperature monitoring points (A-F). The locations of the cross sections were chosen in order to intersect the gear meshes within the machinery. Temperature measurements were made at each of the test locations while the drive was operated at the rated load. Figure III-4 illustrates the temperature distribution measured at one of the cross sections.

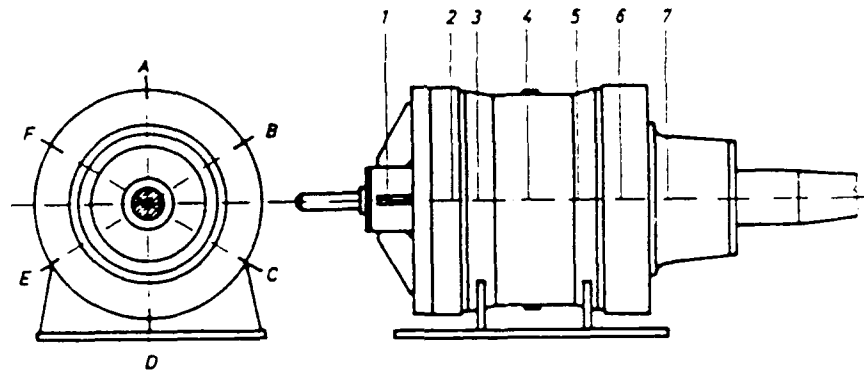

Figure III-3. Cross Sections of Gear Drive for Temperature Measurement
[Ref. 20]

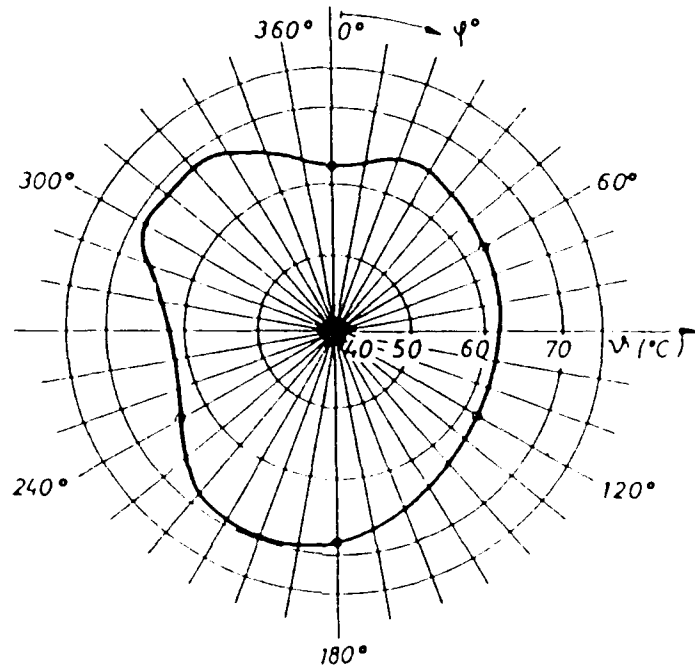

Figure III-4 . Temperature Distribution of Reducer in Cross Section 2
[Ref. 20]

Gulyas used the conservation of energy equations and the Newtonian heating rule along with the material properties in order to calculate the power loss occurring at each cross section. The temperature measured was converted to a form that was used as an indication of the gear mesh condition. Figure III-5 illustrates the change in power loss occurring between two tests of the gear drive.

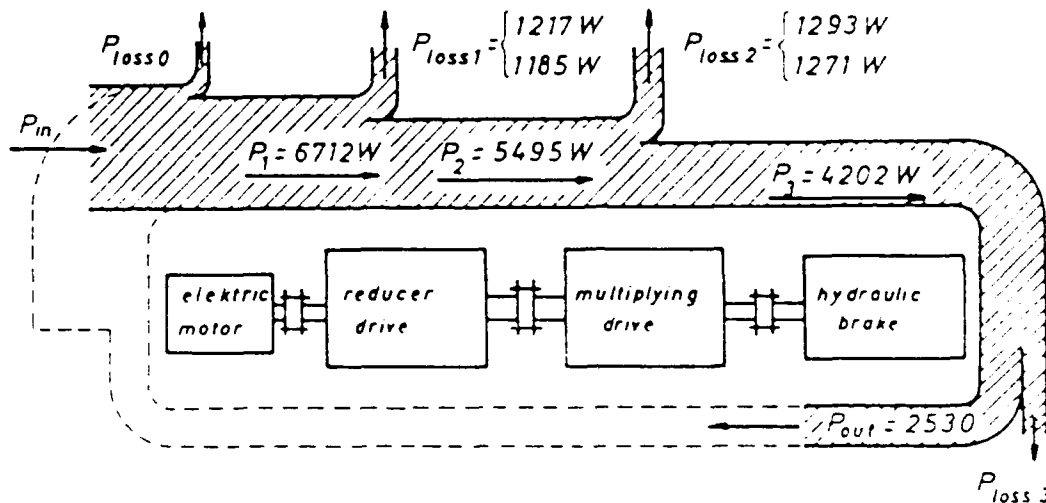

Figure III-5 . Power-transmission in Gear Drive Test Rig [Ref. 20]

This particular test utilized new gears that were being broken in with the result that the power loss decreased as the test proceeded. In theory, measurements that showed an increase in the power loss across a gear mesh would indicate that something unusual was occurring to the gears. The approach is interesting and shows how traditional monitoring methods can be effectively used in condition monitoring when innovatively utilized.

2. Pressure Measurements

Goldman [21] noted that in earlier times, when machinery ran at slower speeds, the pressure-volume (P-v) diagrams were commonly used as an indication of the condition of reciprocating machinery. As machinery speed increased the simple mechanical techniques used to correlate cylinder pressure and piston position were no longer practical. Goldman described how the use of an electronic signal, called a keyphasor,

and the changing time output from a piezoelectric pressure transducer could be used to produce an output that could be related to the information provided on a P-v diagram. The keyphasor produces an electronic pulse for every machine revolution and can be used as a trigger signal for an oscilloscope with memory capabilities. Recording the pressure signal over several cycles of operation and then averaging these signals together produces an averaged signal that shows the changing pressures occurring within an individual cylinder during operation. This technique of averaging signals is very common in vibration monitoring and will be described in a later chapter of this report.

3. Thrust Measurement

Charbonneau [22] presented an experimental method using thrust measurements to monitor the condition of motor operated valves. The paper reported on the progress of experimental research in the nuclear power generation industry. The technique is quite different from traditional thrust measurements performed on equipment such as turbines. The signal produced by a transducer measuring the thrust of a valve stem is analyzed to determine the condition of the motor operated valve. Figure III-6a shows the measurement of thrust. Figure III-6a also shows how the events in the measured waveform can be correlated to the dynamics of the operation of the valve. Changes in this signature can be used to detect failures in valve components. Figure III-6b is another method of monitoring utilizing the electrical signal to a control switch on the valve. The signals produced in this method are repeated for each operation of the valve and may be effectively monitored by use of a pattern recognition routine. It does not take much imagination to see that this form of transitional signal is not uncommon in other machineries, especially in equipment such as loaders or hoisting devices in weapons systems.

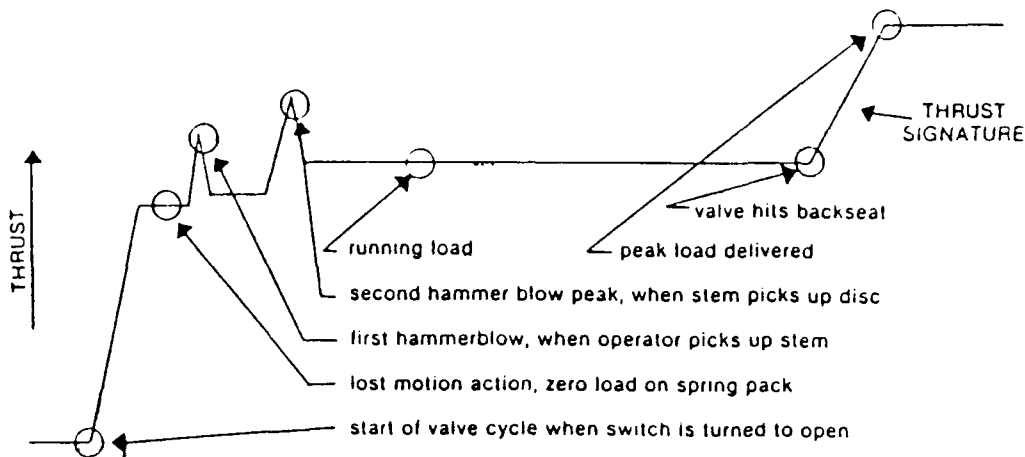

Figure III-6a. Thrust Signal Measurement from Motor Operated Valve During a Close-to-Open Cycle [Ref. 22]

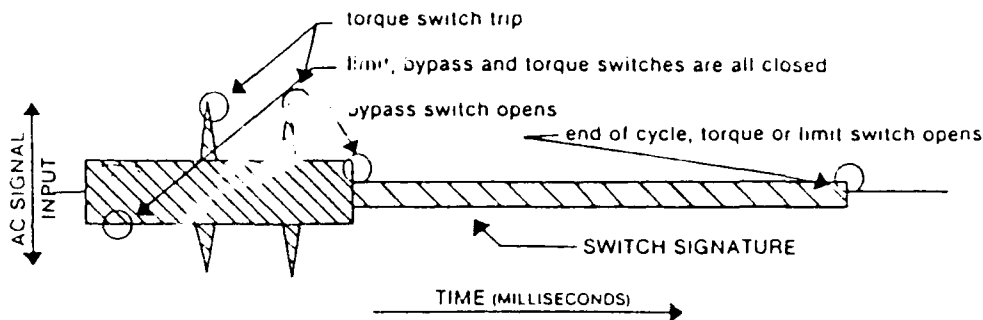

Figure III-6b. AC Signal Measurement from Motor Operated Valve During a Close-to-Open Cycle [Ref. 22]

4. Current Monitoring

The technology used in this method of monitoring is not new or particularly innovative and is not widely explored in the literature. However, this method has very wide applications for use in monitoring alternating current (AC) electric motors. Starting, running and shutdown current levels and wave forms for motors are all features that can be used to detect faults in the prime mover. Because of the cyclic nature of the operating current many of the techniques used in vibration monitoring appear to be applicable in this method of monitoring. Figure III-7 is the frequency spectrum produced from an operating electric motor.

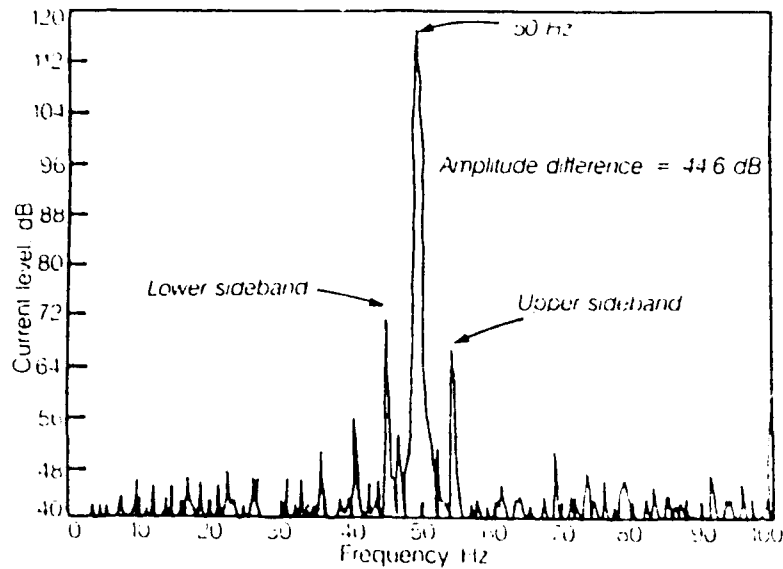

Figure III-7. Frequency spectrum from the Current Drawn by an AC motor [Ref. 23]

Figure III-7 shows how spectrum analysis of the current drawn by the motor produces distinctive frequency components that can be correlated to the dynamics occurring within the motor. The frequency spectrum can be used to identify specific problems that are difficult to detect using other monitoring techniques simply because of the construction of motors.

5. Acoustic Emission Transducers

Verbrugge [24] described tests performed on industrial low pressure feed-water heaters. The tests utilized an acoustic emission transducer to detect the increase in high frequency noise (100 - 300 KHz) which is characteristic of some types of leaks. Figure III-8 illustrates a series of frequency spectrums produced from the output of the acoustic emission transducer.

The data obtained from the transducers is compared to a baseline spectrum taken when the heater was leak free. The results of the testing indicated that the method was very successful in detecting leaking tubes. Use of this method does not require penetration of the heater, but the transducer did require a special mounting device to be fabricated due to the high temperature of the heater shell.

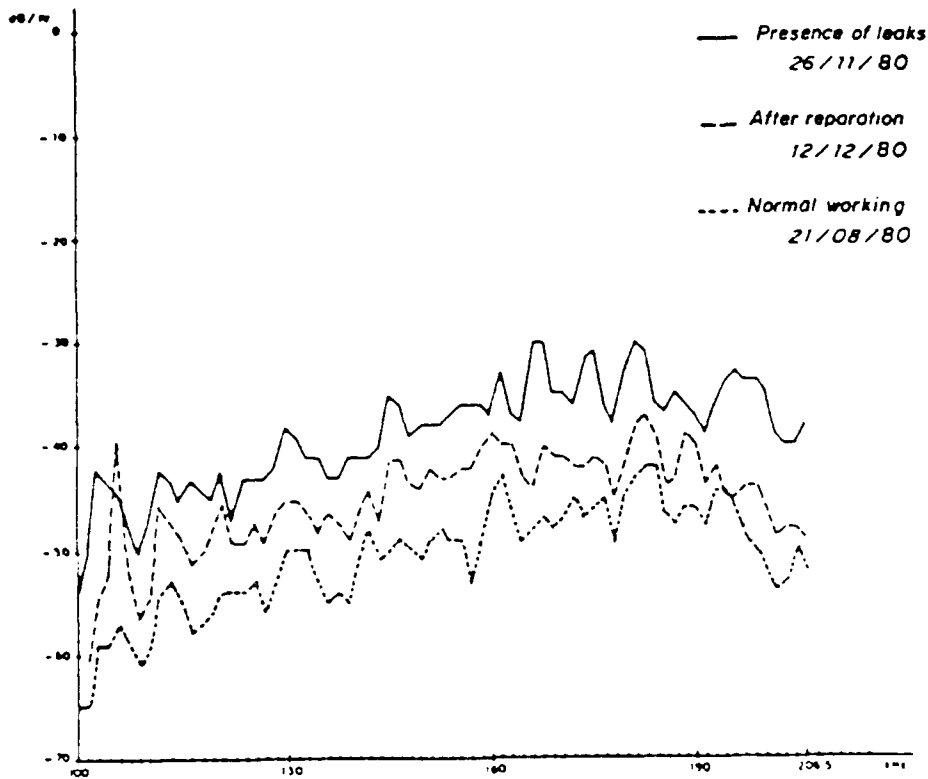

Figure III-8. Trending Spectra of Acoustic Emmission Transducer Indicating Leak Developing [Ref. 24]

C. Wear Based Monitoring

Wear debris is generated by relative motion between load bearing surfaces of machine elements. Hence it is possible to assess the condition of these surfaces if the wear debris were collected and analyzed. The various techniques currently being employed or being researched are summarized in Figure III-9. A complete discussion of each of these techniques is beyond the scope of this report.

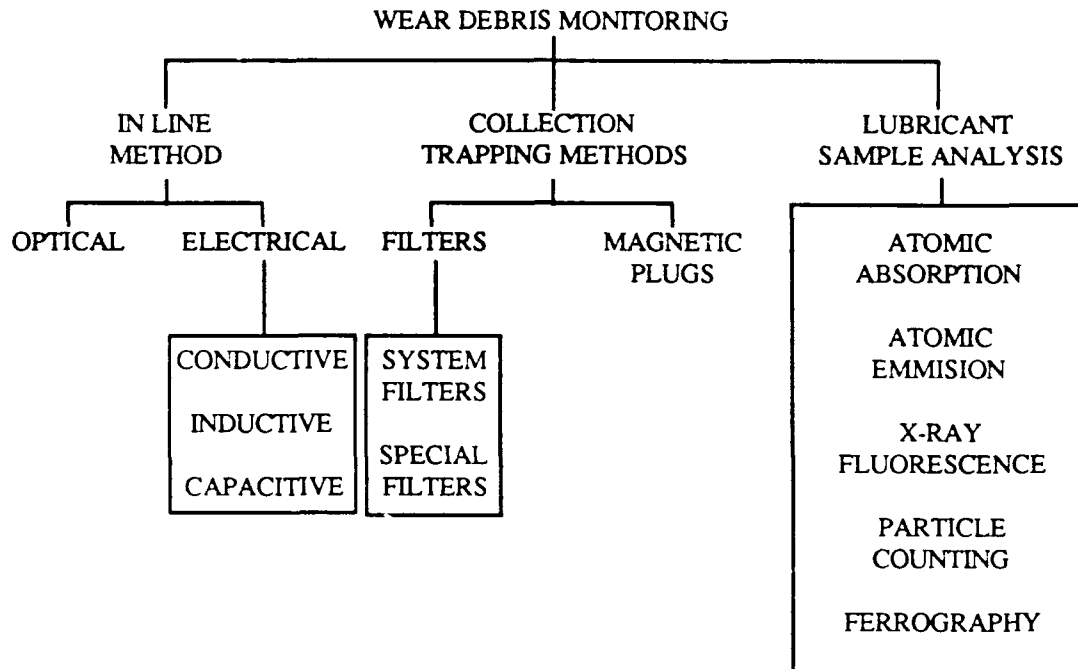

Figure III-9. Wear Debris Analysis Techniques [from Ref. 3]

1. Introduction

Often in the literature lubricant and wear debris monitoring will be referred to as Tribology. Czichos [25] defines Tribology as, "the science and technology of interacting surfaces in relative motion and of related subjects and practices." The field of tribology concerns much more than condition monitoring. It is an inter-disciplinary study that covers many scientific fields. Czichos describes it as a concept that includes the study of the transmission and dissipation of energy in machinery and includes areas of friction, wear, and lubrication. Machinery condition monitoring is only a specialized aspect of tribology.

The minimization of wear is the basis of this concept. The consequence of the wear process is the most fundamental problem involved in machinery maintenance. Milder and Sioshansi [26] estimated the

annual cost for correcting problems caused by wear to be as high as \$100 billion, and in 1975 the maintenance performed on naval aircraft as a result of wear amounted to more than \$240.00 per flight hour. These numbers were compiled several years ago and have no doubt risen. If wear can be minimized, even if it can never be totally eliminated, the repair costs can be significantly reduced. Additionally, if the wear that is occurring to a machinery component can be quantified, then the worn part can be replaced at an optimum time, not after failure has caused additional problems. Czichos [25] breaks the wear into four categories:

- surface fatigue wear
- abrasive wear
- adhesive wear
- tribo-chemical wear

Wear caused by surface fatigue is the result of stresses occurring at the wear surface of a component. These stresses are often referred to as Hertzian stresses in the literature and result in a pitting of the surface. This type of wear occurs without physical contact with another surface and is often the result of the interface with the lubricating medium.

Abrasive wear can occur when two surfaces of differing hardness are in contact with each other, or when two surfaces are in close proximity with hard particles in between. Czichos terms the first situation as two body abrasion and the second situation as three body abrasion. Figure III-10 illustrates these two mechanisms. Generally, the hard surface rubs against the softer surface resulting in the removal of material from the softer surface.

Adhesive wear occurs when two surfaces are brought into contact and become joined. Damage occurs when this joint is broken. Scuffing or cold welding are terms often found in the literature to describe this type of wear.

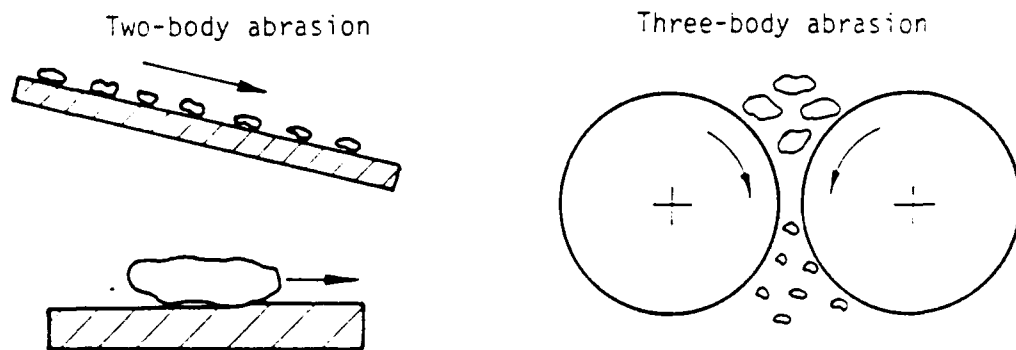

Figure III-10. Two Body and Three Body Abrasive Wear Mechanisms
[Ref. 25]

Tribo-chemical wear is different from the other three wear mechanisms in that the environment plays an important role in the wear process. The difference between this method and the others arises due to chemical reactions taking place between the surfaces and the wear debris that has been produced.

Czichos [25] stated that in an industrial environment abrasive wear is estimated as the cause of 50% of the wear experienced. The susceptibility of machinery to this type of wear can be tracked to the degradation and contamination of the lubricant. The contamination is the result of build up of the wear material and the ingestion of silicon by the machinery. Czichos presented information relating the size of wear particles to the wear being experienced by a machine and is shown in Figure III-11.

Silicon is a contaminant of lubrication that accelerates abrasive wear which can be introduced during the intake of air in internal combustion engines and reciprocating compressors. In addition to contributing to abrasive wear, degradation of the lubricant can also result in increasing susceptibility to adhesive wear. The quality of the lubricant can be reflected in the color, pH, and viscosity of the fluid. The above information illustrates the importance of lube oil and demonstrates the need for wear debris monitoring in condition monitoring programs.

Regime	Particle description and major dimension, d	Surface description	Wear rate
(a)	Free metal particles; d < 5 μm	Varies between polished and very rough	→ Zero
(b)	Free metal particles; d < 15 μm	Stable, smooth layer with a few grooves	Low
(c)	Free metal particles; d < 150 μm	Ploughed with evidence of plastic flow and surface cracking	High
(d)	Red oxide particles, α -Fe ₂ O ₃ , d up to 150 μm	Ploughed with areas of oxides on the surface	High
(e)	Black oxide particles γ -Fe ₂ O ₃ , Fe ₃ O ₄ , FeO, d up to 150 μm	Ploughed with areas of oxides on the surface	High
(f)	Free metal particles, d up to 1 mm	Severely ploughed, gross plastic flow and smearing	Catastrophic

Figure III-11. Relation of Wear Particle Size to Level of Wear [Ref. 25]

Earlier the wear debris monitoring techniques were broken down into three broad categories: (Figure III-9)

- lubricant sample analysis
- collection/trapping methods
- in-line method

These techniques are briefly discussed below.

2. Lubricant Sample Analysis

In general these techniques require samples of lubricants to be drawn from machinery and analyzed by specialized equipment, often located in central laboratories away from the operating environment. In general these techniques are well understood and are described in most references dealing with lubrication or tribology. The major problems in the use of these techniques are the expense involved in the procurement of the testing machinery and the high cost of processing samples. Gulyas [20] noted that the cost of the wear debris monitoring equipment used in his experimental study was well over \$30K with the cost of processing a single

set of data about \$5.00. Another area of concern with these methods of monitoring is the need for skilled laboratory analysts to interpret the test results. In addition, many of these techniques do not appear to be easily automated. As such, the authors feel that the use of these techniques is not conducive in developing future condition monitoring techniques. Instead more emphasis should be placed on the remaining two areas; collection/trapping and in-line methods.

3. Collection/Trapping Methods

This method of wear debris based analysis has seen extensive use in the aerospace industry and includes the use of filters, magnetic plugs, and magnetic chip detectors. Often the use of these methods includes the parallel use of such techniques as pressure measurements. In addition there has been some effort to develop techniques to determine the size of particles trapped by filters and the amount of material trapped in filters. These methods are essential in proper maintenance, but seem to have limited use in monitoring.

4. In-Line Method

The in-line method appears to be a technique where much emphasis is being placed in the development of new technologies. The method enables monitoring of lubricants or wear particles while systems are operating, and can provide information in a form that can be used by processing systems to evaluate machinery operation. In many cases devices have been developed or are being developed that duplicate certain aspects of the laboratory based lubricant sample analysis techniques. This trend will allow monitoring system designers to 'pick and choose' techniques that compliment each other or choose devices to fill perceived gaps in monitoring that other techniques may not be able to measure. Several innovative concepts found in the literature that are applicable to this aspect of monitoring will be presented. These examples should provide the reader with a feeling of where research in this area is taking place.

5. Chemical Microsensors

Jarvis et al. [27] presented a fascinating paper on the development of what they term chemical microsensors. The technology for these devices has been developed from the microelectronics fabrication process used in semiconductor production. From the description of these devices, they appear to be a bridge that enables wear debris monitoring techniques found in the laboratory to be moved into field applications. The concept behind these devices is that small, rugged, and sensitive devices can be developed to detect specific chemicals in fluids of operating machinery. The authors of this reference have directed the application of these devices to internal combustion engines, but it appears the devices could be useful in many other fluid systems. Several specific applications, mentioned in the reference, for which sensors could be developed include:

- monitoring concentration of additive in fluids
- monitoring rate of consumption of additives
- measurement of fluid pH
- contamination of lubricants by water or fuel
- formation of degradation products
- accumulation of material on filters

Jarvis et al. [27] indicated that at least four different types of devices were developed; a surface wave device, an optical waveguide device, a chemically sensitive organic chemresistor, and a vapor sensitive metal oxide semiconductor. A brief description of these devices will be presented.

5.a. Surface Acoustic Wave (SAW) Devices

The authors listed several previous uses of SAW devices. In operation these devices use electronic equipment to produce a sound wave that oscillates at a resonance frequency on a piezoelectric surface. This wave is called a Rayleigh sound wave. The piezoelectric surface of the device can be coated in such a manner that only material of interest will be deposited on it. Changes in the mass of the surface will result in a change to the frequency of the surface wave, and support electronics can use the new frequency to determine the amount of mass that has been deposited. The authors noted that the coating was developed for detection of only

limited materials. The data presented by the authors indicated that the devices responded in a fairly linear behavior, but mentioned that the devices were susceptible to temperature and interference induced drift.

5.b. Optical Devices

Development of optical devices has been devoted to two types of sensors:

- sensors that mimic the techniques used in spectroscopy
- sensors that use a reversible optical waveguide for detecting low concentration of vapors

The first class of devices incorporates the technology of ultraviolet, visible, and infrared spectroscopy into microsensors. This would allow evaluation of fluids without the extensive laboratory equipment currently required to test lubricating and hydraulic oils. The thrust of the research in this area is in monitoring the level of antioxidants in the lubricant. The authors stated that the level of antioxidants in the lubricating oil was an indication of lubricant degradation. The measurement of this quantity with a microsensor was still in progress so detailed information on the construction and operation of these devices was not available. However, a preliminary device to detect ammonia vapors has been developed. Figure III-12 illustrates the experimental optical waveguide system.

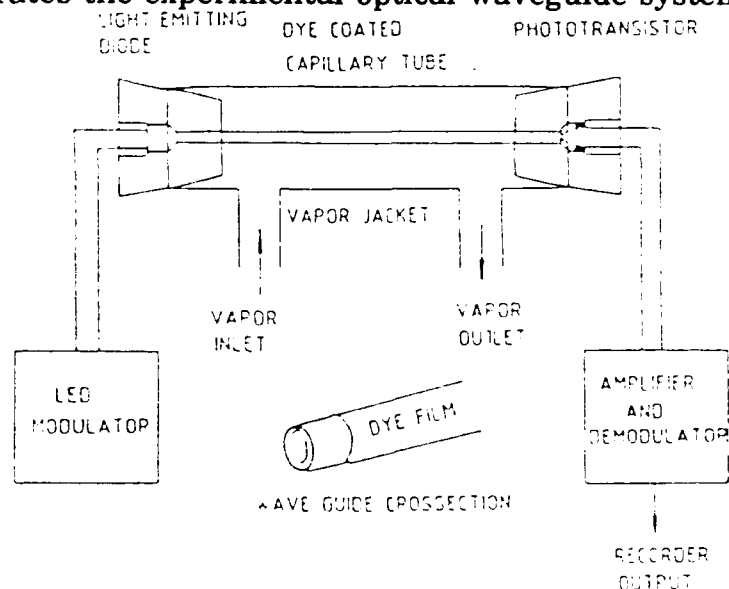

Figure III-12 . Experimental Optical Waveguide System [Ref. 27]

The device measures the concentration levels of the materials of interest in vapor by the reflections produced from the interactions between the vapor and the specially selected dyes used to coat the capillary tube. The authors report that the support electronics for the sensor occupies only a "few" square inches on a circuit board. The length of the tube is 90 mm. The sensitivity of the system to shock was not discussed, however the authors did note that one of the limitations of previous efforts in this area was the complexity of the optics and the unsuitability of the devices to use in the field. It is assumed that the new device attempted to correct these problems.

5.c. Organic Semiconductors

The third area of research discussed in Reference [27] is in the area of organic semiconductors. The basic idea behind this research is the development of semiconductor material that is sensitive to specific chemicals. The semi-conductor material will change resistance when these chemicals are detected. The support electronics would measure the change in resistance and produce electrical signals proportional to these changes.

5.d. Inorganic Metal Oxide Semiconductor Devices

The final area examined in Reference [27] dealt with inorganic metal oxide semiconductor devices. This research utilized commercially available devices described as "low-cost solid-state metal oxide semiconductor gas sensors." The devices are sensitive to combustible hydrocarbons which are oxidized on the surface of the semiconductor devices. This causes a change in the resistance of the semiconductor which is then measured by supporting electronics. A sample of the lubricant from a system is drawn and placed in the system. This device is used to monitor lubricant degradation by monitoring the level of the combustion products produced by the heated lubricant. This device does not appear to be easily adaptable as an automated monitoring system, however, it may be easily adapted to use on ships where evaluation of lubricant quality could be performed in a more timely manner, much like boiler chemistry .

6. Surface Layer Activation

Surface layer activation is a wear monitoring technique that uses radioactive isotopes to lightly irradiate wear surfaces of machinery. As the wear process occurs the radioactive material is worn away and results in a change in the activity emitted from the surface. The change in activity can be correlated to the amount of material that has been removed. This method of wear monitoring is described in detail in References [26, 28] and has several aspects that would make it desirable for condition monitoring of equipment [26]:

- capability to evaluate wear while equipment is in operation
- monitoring does not require access to the monitored component
- useable in hostile environment
- has capability for automation

Use of this procedure is reported to have occurred as far back as 1949 and has had applications in the monitoring of reciprocating internal combustion engines. Milder and Sioshansi [26] noted the possible use in monitoring the corrosion of tubes in steam generators and gas turbine engines. The methods could be extended to practically any type of machinery in which a determination of the amount of internal wear is important. The basic principle behind this method is that components of machinery are exposed to radionuclides to change the characteristics of the component in a very thin region near the component surface. As the wear process occurs, the area of the component irradiated wears off and sensors can detect and measure the amount of wear that the component experiences. Blatchley and Sioshansi [28] described the use of this method in two different manners. In the first manner the radionuclide is called a "marker" and the monitoring is performed to determine the amount of material remaining on the activated component. The second method of use is called a "tracer." In this method the radionuclides from the surface of the component are monitored as they are released into the medium surrounding the monitored component. Use of both methods requires the wear debris to be removed from the area where it is produced and would be accomplished by the lubrication or by air flow.

Use of the marker technique alone is evidently the standard method of utilizing this technique. When monitoring the component, the radio-activity detected by the probe is concentrated in one area and the probe is adjusted to measure the specific nuclide used in the marking. Milder and Sioshansi [26] provided the detail on the selection of radioisotopes and the parameters to be examined when using the process. This method is reported as extremely accurate in determining the amount of wear that a component has experienced. The use of the marker technique has made it possible to evaluate the differences produced by operating at various conditions. The different conditions include operating at different temperatures, loads, and even with different lubricants.

Even with this level of success with the technique, Blatchley and Sioshansi [28] noted that a more effective system could be achieved when the marker technique is combined with the tracer technique. In this system, monitoring of the wear can be performed both spatially and temporally, permitting the monitoring of transient wear. Costs for this type of system are not discussed, but from the literature it appears that the highest costs would be for the probe and the initial radiating of the component. The other required items consist of standard analyzers to monitor the signal. In addition, computer programs for manipulating the measured data in order to correlate to wear are available.

The major problem area found in this technique is, of course, the safety when using radioactive processes. This problem must be addressed and completely answered if this technique ever achieves wide spread use. The safety of personnel and the work environment cannot be reduced.

D. Summary

In summary, the techniques described in this section indicate that both traditional monitoring and wear based monitoring have monitoring capabilities that deserve further research and development. The techniques presented in this chapter should be considered when designing condition

monitoring systems. Designers should be aware of the broad methods of monitoring available and should not allow preconceived ideas developed from familiar techniques influence the decision on selecting specific methods for use. Instead, an imaginative and in-depth scientific investigation of the system to be monitored should be conducted and the results of this process should point towards the logical techniques that make the monitoring effective and efficient.

IV. VIBRATION MONITORING TECHNIQUES

A. General

In Chapter III, vibration monitoring was introduced as one of three techniques being used for condition monitoring. Machinery vibration is a prime indicator of condition and can play a key role in condition monitoring. Vibration monitoring involves the measurement and analysis of the vibration associated with machinery operation and is specifically aimed at the detection and identification of machinery faults. Figure IV-1 illustrates the method of monitoring the vibration of machinery.

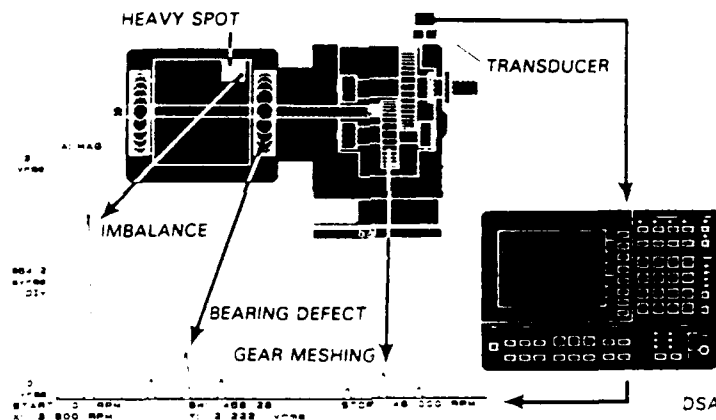

Figure IV-1. Vibration Monitoring of Machinery [Ref. 29]

Vibratory motion is a phenomenon inherent to all machinery regardless of material condition and is measured in terms of the physical motion of the machine or the sound produced by the motion. Measurements of mechanical vibration are favored for machinery condition monitoring purposes, whereas acoustic vibration measurements have greater importance and use in noise control and reduction analyses [30].

Smith [31] notes that an oscilloscope can be used to examine the electrical signal that represents the vibrations of the machinery. Use of this signal may result in detection of specific features of the signal, but the vibration signal is normally very random and additional electronic equipment and signal analysis techniques are required.

The techniques of using vibration signals for condition monitoring are varied and difficult to categorize in a unique way. Braun [32] discusses various vibration monitoring and analysis techniques. In general the various techniques may be broadly classified under the categories shown in Figure IV-2. Mathew's paper [3] describes and discusses overall machinery condition monitoring using vibration analyses in a systematic manner.

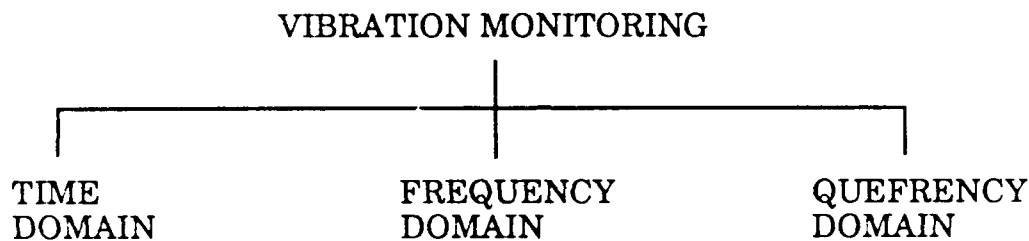

Figure IV-2. Vibration Monitoring Techniques [Ref. 3]

This diagram indicates that there are three broad categories of vibration monitoring techniques. The first two categories examine the measured signal in what are commonly called the frequency and time domains. The third category, quefrequency domain, is based on the cepstrum which is defined as the spectrum of the logarithm of the power spectrum.

Basic to most vibration monitoring techniques is the assumption that once a machine is placed into service and a baseline vibration signature is obtained, subsequent change in the material condition of the machinery will be reflected by a change in its vibration signature. Conversely, if there is no change in the vibration signature, then there has been no change in the material condition of the machine. This assumption implies that the

machinery being monitored is at the same loading conditions as prior measurements and that the machinery is operating at a constant speed. For most machineries this assumption can be made, minor load variations and speed changes will not greatly affect the measurement and computer programs have been developed to 'shift' or align measurements to account for these minor variations.

In controlled laboratory conditions the duplication of results for identical conditions is not difficult to obtain. However, in actual practice exact reproduction of signatures is not expected, but similar operating conditions yield signatures which are unmistakably "the same", this repeatability promotes the use of vibration monitoring for condition monitoring.

Another concept basic to vibration monitoring is the concept of source-path-receiver [30]. The oscillatory motion of a machine represents the response to dynamic events internal or external to the machinery. Figure IV-3 illustrates this concept.

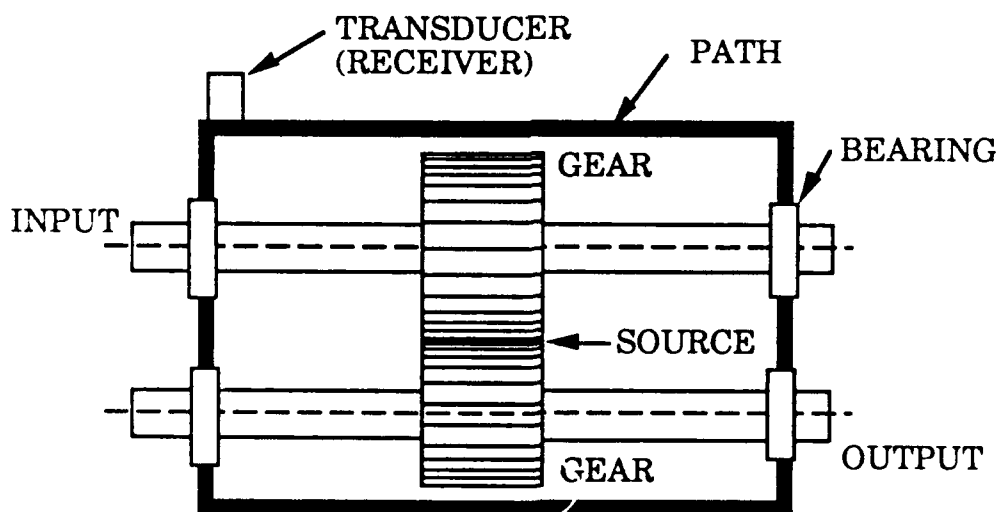

Figure IV-3. Source-path-receiver Model.

This figure depicts a gearbox with the gear mesh producing the vibrations of interest. Other examples of internal sources are rotor imbalance, coupling misalignment, bearing defects, and worn components. Each of these examples represent defects which when corrected will reduce the amplitude of the vibrations produced by the machinery. Examples of external sources are load variations, changes in flow conditions, and vibrations of adjacent equipment. All represent problems not associated with defects in the monitored machinery. The transmission of the forces from their sources follows a path through the machinery's structure. This path can effect the vibration produced by the source in several ways and include amplification, modulation, and damping. The transducer is the final part of the path and represents the receiver of the modified vibration produced by the source.

B. Early Vibration Monitoring Techniques

An understanding of the early vibration monitoring programs is important in order to comprehend the more recent techniques. Early vibration monitoring programs utilized the vibration signal from machinery to produce a measurement of the overall level of vibration that the machinery was experiencing. This overall or broad band vibration level is normally the root mean square (rms) level of the vibration signal. The equipment used for measuring this level is much like a volt-meter which indicates the rms level of an electrical voltage signal. This method is simple, adaptable to hand held devices, and produces data values which can be recorded and manipulated easily.

To assist maintenance managers in correlating the measured levels to machinery condition, standards were developed by engineering organizations and many manufacturers started to provide recommendations and guidelines for acceptable levels of vibration for their products. Figure IV-4 illustrates the types of information available in these standards [33]. This figure shows an example of a vibration severity chart and it can be seen that relative increases and not absolute vibration levels are the most important. This chart is drawn up for vibration measurements made in the 10 Hz to 1 kHz frequency range according to

International Standards (ISO 2372/3 & 3945). This chart also shows that an increase of x2.5 (8 dB) indicates a change in the condition classification, and an increase of x10 (20 dB) indicates that vibration levels have reached the "danger" zone. The broad band vibration of a piece of equipment could be compared to the levels on a chart such as this and a determination of the condition of the equipment could be made. There are several problems with this type of monitoring technique. Randall [34] points out that these standards apply to "typical" machinery and maintenance personnel can never be certain whether the machinery they monitor is typical. This leads to a situation like that discussed in preventive maintenance programs, where some machinery is being given attention it does not need and other machinery is failing because it operates "quieter" than it should. To correct this problem, the literature shows that users of vibration analysis equipment have generally developed in-house standards based on experience to set the acceptable vibration levels for machinery. In many cases these new limits are often far more stringent than those recommended by outside sources.

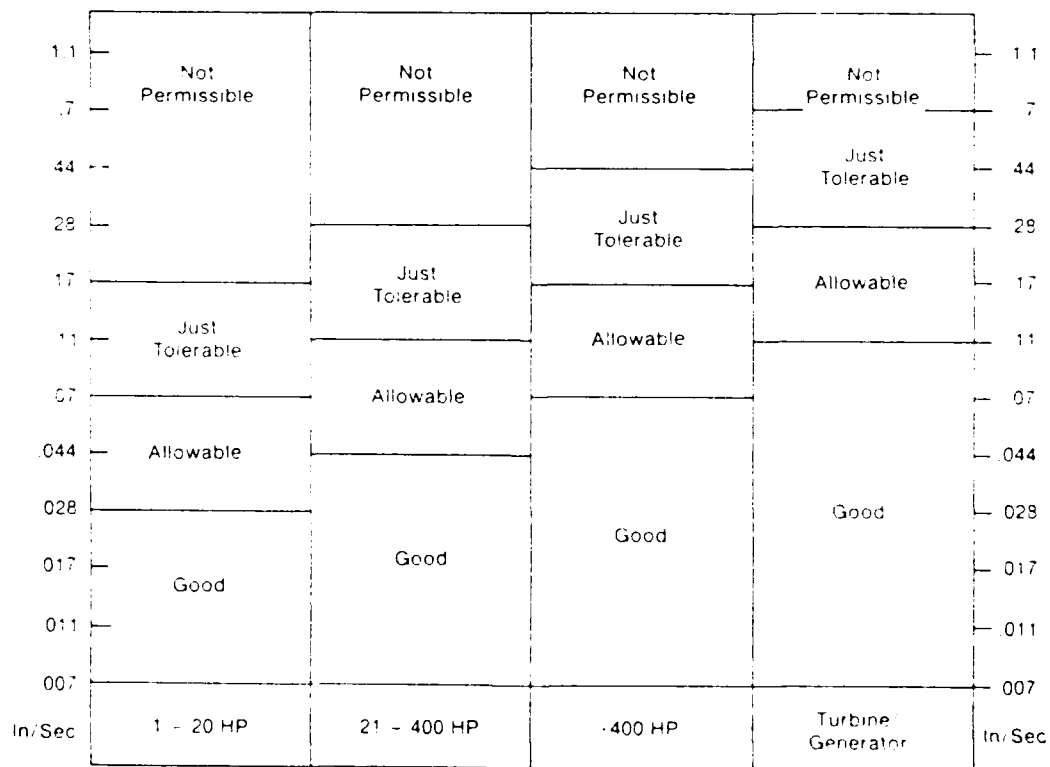

Figure IV-4. Example of the Vibration Severity Chart Used for Assessing Machine Condition [Ref. 33]

A second problem with this type of chart is that no diagnostic information is provided from the vibration level. When a piece of machinery has an unacceptable level of vibration, the maintenance personnel has no way of determining what component has failed [34]. To correct the vibration problems, inspections requiring the machinery to be fully disassembled are performed to determine the cause of the vibrations. This process, as has been discussed earlier, is wasteful of both time and material.

A third problem with broad band levels is that they are not sensitive to damage occurring in the machinery. Significant changes in the broad band level of vibration due to damage is slow, giving the impression that nothing is wrong with the machinery until a point where failure is imminent [34]. Elbestawi and Lau [35] support this observation stating that the broad band level frequently does not detect early stages of deterioration in machinery condition. As such, broad band vibration level has little support as a monitoring technique among the leading authors of condition monitoring literature. This has lead to development of improved monitoring techniques using frequency domain analysis.

C. Frequency Domain Analysis

The most popular technique for analyzing vibration signals is frequency domain analysis. Smith [31] notes that frequency domain analysis is referred to by an endless number of various names including frequency analysis, wave analysis, Fourier analysis, FFT analysis, spectral analysis, and many others. For all practical purposes these names mean the same thing, they present information indicating the level of vibration at a particular frequency.

Braun [32] notes several reasons why frequency analysis of vibrations is the method most often used in condition monitoring programs:

- large reduction of data from time signal format
- data presented in easily understood format
- data characteristics easily extracted
- wide spread availability

It is arguable, but the final reason is the primary reason for the popularity of frequency domain analysis. The availability of equipment and software with the Fast Fourier Transform (FFT) algorithm has enabled frequency analysis to become significantly more popular than others.

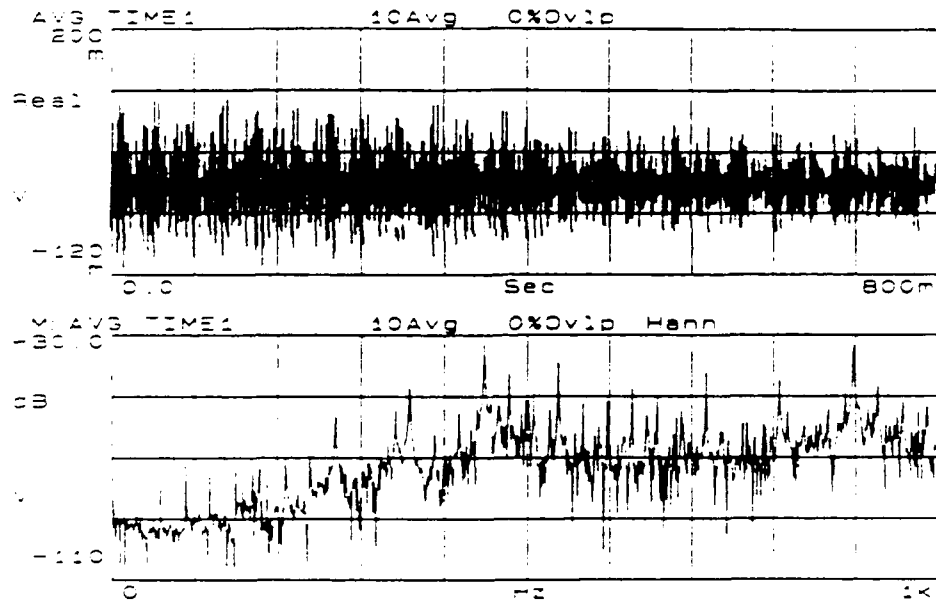

Figure IV-5. Time and Frequency Domain Representations of a Signal.

Figure IV-5 illustrates both time and frequency domain representations of a signal. The upper portion of this figure depicts a time domain signal from an accelerometer and the lower portion of the figure depicts the same data after an FFT has been performed on it with the result being a representation of the signal in the frequency domain. This frequency domain representation is used for monitoring purposes and will be called a frequency spectra or spectra in this report.

The analysis of time signals and their spectral representations is not new and have long been studied by electrical and electronics personnel. Many of the vibration analysis techniques that fall under the frequency domain category rely on relationships which are well established and tested and much of the vibration analyst's work is to relate signal information to the system it represents. The spectral display gives frequency analysis its strength as a machinery diagnostics tool. This is especially true for rotating machinery due to the machinery's cyclic nature of operation. When the vibration signal is transformed into the frequency domain, the discrete frequencies and amplitudes in the spectra can be directly related to specific conditions occurring to the machinery. Figure IV-6 is an example where several distinct peaks in the spectra are related to the dynamics of the machinery monitored.

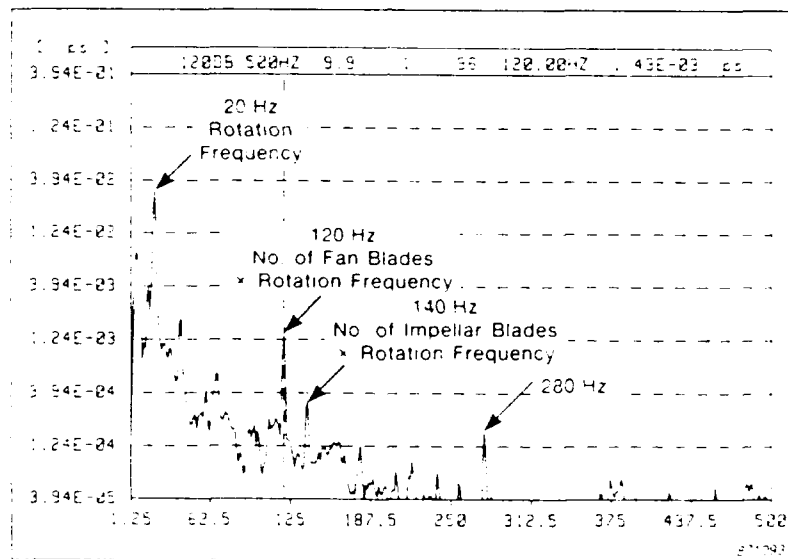

Figure IV-6. Narrow-band Diagnostic Spectrum from a Reactor Coolant Pump [Ref. 33]

In this spectra prominent frequency components can be related to the dynamics of the machinery operation. Easily identified are shaft rotational speed and multiples of the rotational speed dependent upon the physical construction of the pump. With this process the frequency components that

make up the time domain signal can be separated, and in theory, evaluation of machinery condition can be made by analyzing the changes that occur to the frequency components of these spectrum values.

Two different frequency ranges are considered in frequency domain analysis: broadband and narrowband. Broadband has a rather wide frequency range, typically 10 Hz to 10 kHz in naval applications. Broadband analysis quantifies the overall characteristics of machine vibration in a wide frequency range at the particular measurement location. Broadband measurement does not usually have enough frequency resolution to evaluate spectral peaks. Narrowband has a narrow frequency range in which a small frequency resolution is obtained. With enough knowledge of the characteristic frequencies of the machinery, the narrowband data can be used to detect the specific faults in the machine. The individual frequency components have proven to be much more sensitive to damage than the broad band measurements. In a monitoring program individual frequencies are monitored for change. Evaluating the changes in these frequencies and relating the change to a machinery's condition, as discussed earlier, is generally gained through experience. However, the literature does provide some guidance. For detection and diagnostics purposes the vibration level of the machine when it is in a known good condition should be used as the reference and subsequent measurements are to be compared to this baseline level. It is stated that when setting alert levels on machinery monitored in the Navy surface ship vibration monitoring program, in the absence of experience or other guidelines, an alert criterion is indicated when a specific frequency component experiences a 6 dB increase from the previous measurement [1]. Reference [34] is more specific, stating that a rise of 6-8 dB over a baseline measurement should be considered significant. This reference continues by noting that a 20 dB increase should be considered as an indication of a serious problem.

These levels can be related to the fault detection and diagnostics process presented in Chapter II. The 6 dB rise would be equivalent to a fault being detected. The 20 dB rise can be thought of as a measure of damage, this level indicates to the operator that shutdown and repair of the

machinery is needed. The use of the frequency of a monitored component could be considered a diagnostic process that assists in locating the probable source of the fault producing the increase in vibration. Use of the 6 dB level for fault detection provides a means to classify the data from frequency spectra and to make comparisons with the statistical parameters calculated.

The most common and the simplest method of using this data is called trend analysis. In its most basic form, the amplitudes of specific frequency components are recorded and the levels compared. Figure IV-7 is a collection of data from a low pressure heater drain pump.

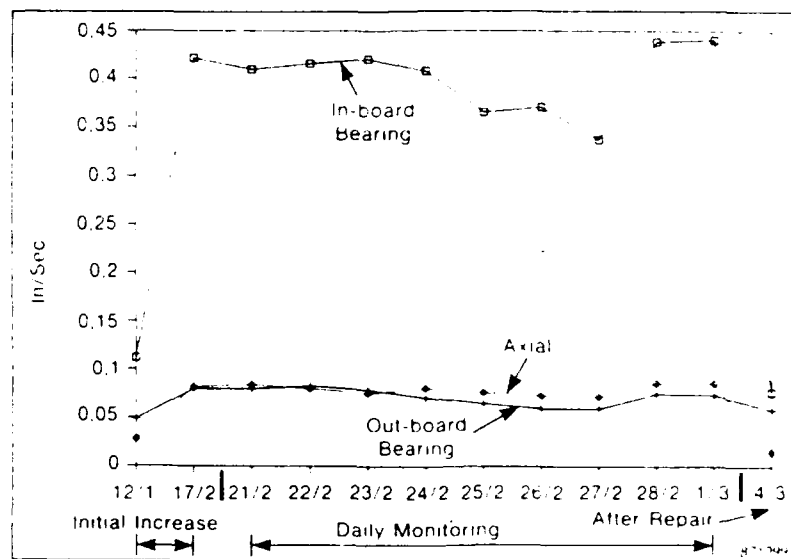

Figure IV-7. Trend Curve from a Low Pressure Heater Drain Pump Measured at 120 Hz [Ref. 33]

The figure shows velocity levels from three different measurement points, two radial measurements made on inboard and outboard bearings and an axial measurement. The measured data was used to produce three spectra and the amplitude displayed occurred at 120 Hz. The data for the inboard bearing shows an increase in level and, after replacement, the level returns to a level near the baseline. This technique is fairly simple, requiring only that the expected machinery characteristic frequencies be known and that consistent measurement techniques be used by monitoring

personnel. But there are several problems with using this type of monitoring process. The first problem is the limited number of machines that can be effectively monitored by hand. It is not difficult to see that the number of machines that can be monitored and the number of frequencies analyzed by manual methods quickly becomes unmanageable. This limits manual monitoring to a small number of machines. In order to increase the number of monitored machines some form of automated system must be used.

Movement towards automated systems quickly leads to new problems that have to be overcome. Two of these problems include normalizing the frequency components to allow for slight changes in speed and developing methods to transfer data to a data processor. This latter problem involves decisions on hard wiring sensors throughout a plant or using equipment that will permit data to be collected by hand, stored on a temporary medium and then transferred to the processing equipment. These problems are not trivial and the costs and time required to overcome them can be significant.

Another problem with trending narrow band data is the spread that can occur in the measured data. Randall [34] notes that individual components can be very sensitive to small load changes. This produces data that can vary significantly. Combine this aspect with variations that can be introduced when several different personnel are taking measurements and data can easily be produced that can vary by the 6 dB criteria. Another problem with using trend analysis is that the response of a component to damage is not always linear, but can be nonlinear [34]. Figure IV-8 illustrates this problem.

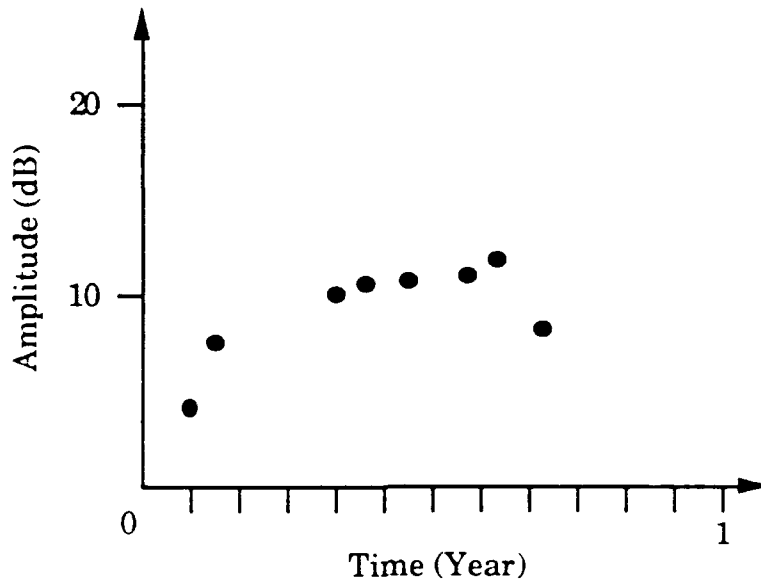

Figure IV-8. Nonlinear Response of Vibration Level to Damage

This nonlinear trend illustrates that using linear predictions to determine when a breakdown will occur can be ineffective. The data shown in the figure indicates a period where the data has reached a stable level, however during this stable period it is very possible that damage to the machine was continuing and could have produced a sudden failure. This response can lead to a false sense of security after the initial rise in level has occurred.

A third problem pointed out by Randall [34] is that many types of faults do not produce changes in single frequency components, but instead produce harmonics or sidebands. This leads to problems in deciding which frequencies to trend on. Figure IV-9 illustrates the harmonics that can appear in a measurement.

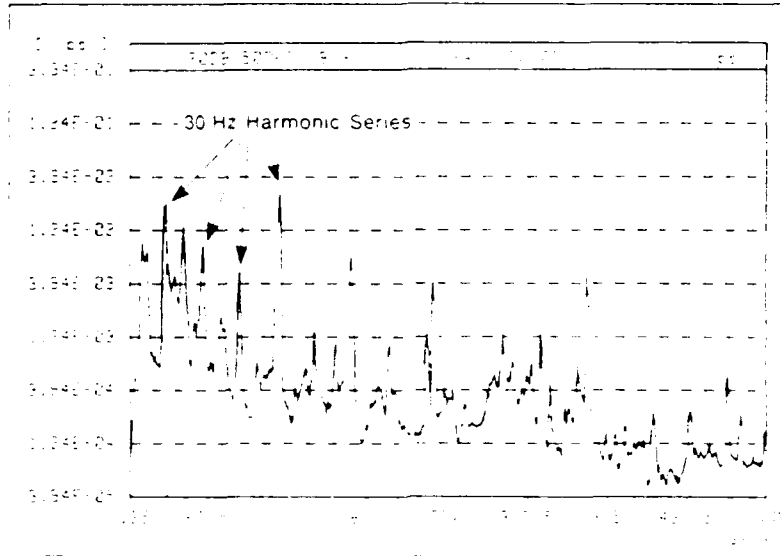

Figure IV-9. Harmonics in a Measurement [Ref. 33]

Figure IV-10 illustrates the appearance of sidebands around a frequency component.

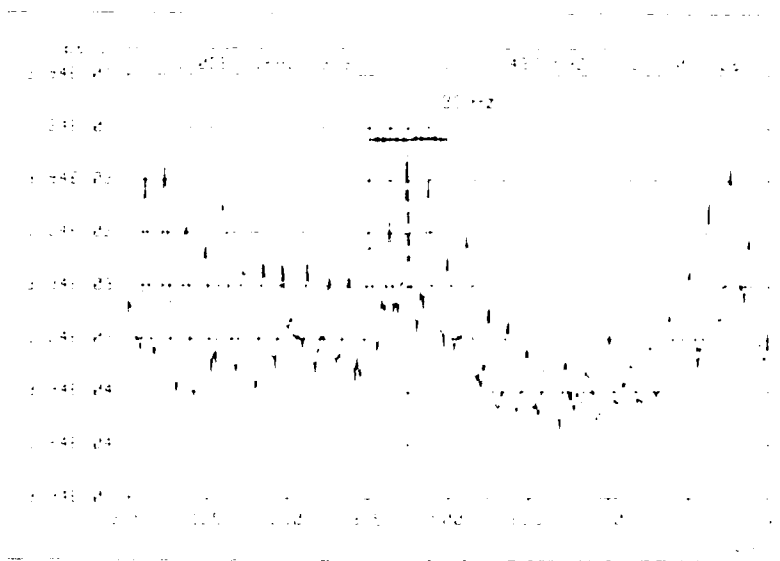

Figure IV-10. Sidebands around a frequency component [Ref. 33]

These phenomena in the frequency spectra make use of frequency domain techniques even more difficult and efforts are being made to develop new techniques to reflect the changes that occur to the frequency components of a measured spectrum. But because of the number of data points to be handled, normally 800 line spectra, the reliance on automated systems and the inherent difficulties already discussed arise.

At this point, the techniques described, with the exception of time synchronous averaging to be discussed next, represent the state-of-the-art in vibration monitoring techniques. There is a significant amount of literature written on the benefits of vibration monitoring, but for the most part, the systems installed in operating industrial plants are some form of trend monitoring based on either broadband vibration levels or narrowband vibration levels. These systems can and have shown good results and are a significant improvement over the situation when no monitoring system is present.

D. Time Synchronous Averaging

Time synchronous averaging, sometimes called synchronous time domain averaging, is a time domain monitoring technique. Time domain techniques utilize the vibration signal in a form that is similar to the signal produced by the vibration transducer. Time synchronous averaging is the only technique in this category that has any semblance of wide spread use in industry. McFadden [36] emphasizes the problem of using frequency spectra for complex machinery such as gear boxes. In these spectra frequency components are so numerous that the spectrum is too complex to analyze. In this synchronous time domain averaging technique, two signals are required, the first is the monitored vibration signal and the second signal is called a keyphasor. The keyphasor acts as a trigger signal. This keyphasor marks the revolution of a shaft and is used to trigger electronic equipment to mark the start of data collection. After many averages the vibrations which are not synchronous with the rotation the

keyphaser is tracking tend to cancel, and the remaining waveform provides an estimate of the vibration related to the shaft being keyed on. This technique is used for gearboxes as it reduces the vibration signal from other components in the system. Figure IV-11 illustrates the process.

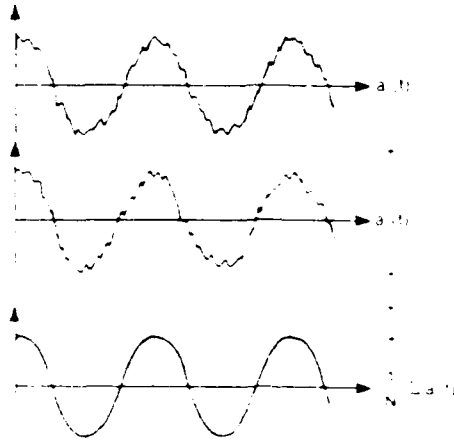
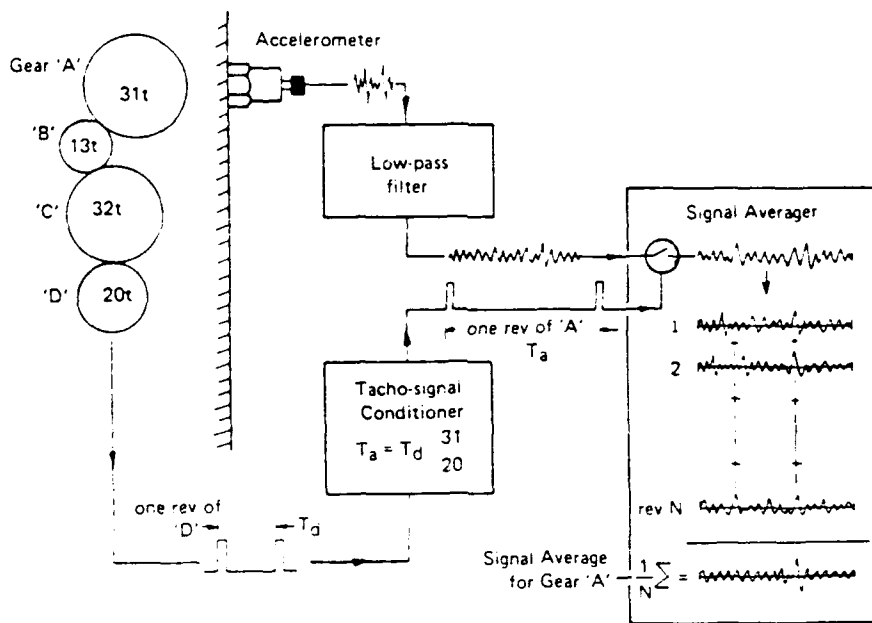

Figure IV-11. Synchronous Time Domain Averaging [Ref. 5]

In the literature this technique is almost exclusively used for analysis of gear faults because of its capability to provide a graphic display of the state of the gear mesh. Figure IV-12 illustrates time synchronous signal averaging for a perfect gear, a slightly misaligned gear, a heavily worn gear, and a gear with a fractured tooth.



(a) Signal averaging applied to gearboxes

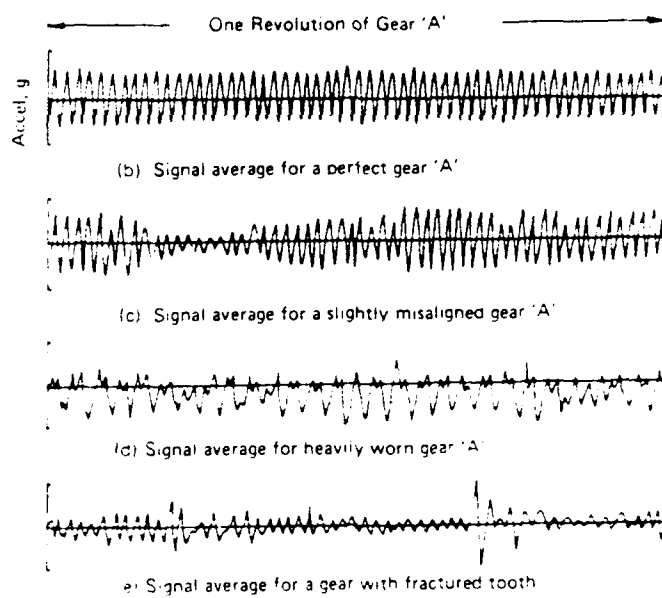

Figure IV-12. Time Synchronous Signal Averaged signals for a Gear [Ref. 38]

E. Quefrequency Domain - Cepstral Analysis

The cepstrum was originally defined as the power spectrum of the natural logarithm of the power spectrum of the signal. Cepstral analysis is a quefrequency domain technique developed to highlight periodicities that occur in the spectrum in the same manner as the spectrum is used to highlight periodic components occurring in the time domain signal. Originally the cepstrum was used in radar and seismic applications, and has proven to be useful in detecting periodicities in the frequency spectra [38]. Elbestawi and Lau [35] noted that when damage occurs to some types of machinery, families of side bands can develop around carrier frequencies and analysis of the spectrum made from monitored data can become very difficult. The families of sidebands become peaks in the cepstrum. The cepstrum also has peaks that correspond to harmonic components in the spectra.

Advantages of using cepstral analysis for condition monitoring purposes include:

- highlights periodicities in the spectra of signals
- represents the total power content of families of harmonics as a single component

The main emphasis of this description is placed on the logarithmic amplitude of the spectrum. The natural logarithm is used in the computation of the cepstrum and this differentiates the cepstrum from the auto-correlation function. In the literature three different cepstrums are discussed [38] :

- the power cepstrum
- the complex cepstrum
- the phase cepstrum

In general the power cepstrum has the most application to condition monitoring, the remaining two cepstrums require phase information not normally obtained in vibration monitoring. Figure IV-13 illustrates a cepstrum.

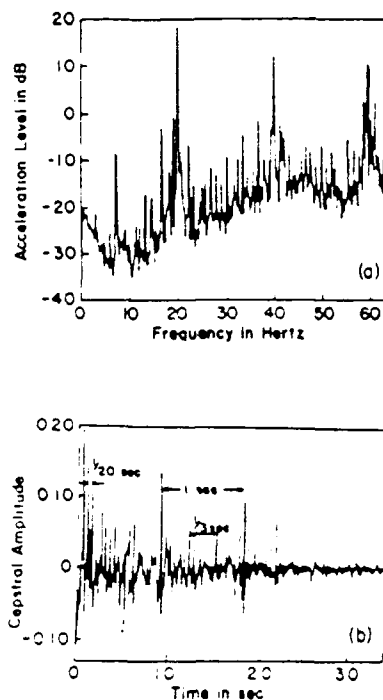

Figure IV-13. (a) Spectrum and (b) the Corresponding Cepstrum [Ref. 13]

In order to differentiate this "new" time domain from the signals in the original time domain, the original developers of the cepstrum devised a clever method of describing occurrences in this "new" time domain. It is very easy to see where the terminology came from:

Cepstrum	Spectrum
Quefreny	Frequency
Rahmonics	Harmonics
Liftering	Filtering

There are many more terms that may be encountered in the literature and Reference [38] lists many, but these four are the most common. The quefreny describes the measurement of time on the horizontal axis of the cepstrum. It has units of seconds. Rahmonics would be a series of spikes appearing in a cepstrum, these spikes would appear at equal spacing.

Chapter 16 of Reference [39] is very helpful in providing one of the few descriptions on how the cepstrum is interpreted. The important point is that the amplitude of an individual spike in the cepstrum represents the power content of its corresponding harmonics that appear in the power spectrum. This result is useful in quantifying the severity of an event. However, Mathew [3] points out that although this amplitude normally increases with severity, research has shown that it can decrease even though the severity of the damage is great enough to secure the machine.

Courrech in Chapter 16 of Reference [39] presents plots utilizing the amplitude of a cepstral event in a manner similar to those used in trend monitoring. Mathew [3] also presents graphs of his research and has excellent explanations on how to interpret the cepstral analysis. Like Courrech, he uses the cepstrum amplitude in a trend analysis.

Only limited experimental research utilizing the cepstrum for condition monitoring purposes is presented in the literature. The material that is presented utilizes the technique primarily in the detection of gear faults, although Lyon [30] has used the technique on combustion engines. Stronach et al. [18] note that cepstral analysis was not adaptable to analysis of reciprocating compressors.

This lack of literature shows that use of the cepstrum is not widespread in the field, but the technique is being presented in several vibration monitoring courses presented by equipment manufacturers and the Shock and Vibration Handbook [39] does have a small section describing its use. But more research needs to be conducted and presented in order to determine its usefulness to monitoring a wide selection of machinery types. Other problems cited in the literature include difficulty in automating the process and difficulty in getting maintenance personnel to use the technique.

F. Amplitude Probability Density Function

Amplitude probability density function (p.d.f.) techniques are a subset of time domain vibration monitoring techniques. Techniques that fall under this category are touched upon in the literature, but no in depth study of them was found. Some research that focuses on certain aspects of the p.d.f. indicates that it may be worthy of additional research. The foundation of the techniques that lie in this category are based on the use of the monitored vibration signal to develop a probability density function and then determine the condition of the monitored machinery based on changes that occur to the p.d.f..

Reference [32] notes that the p.d.f. of machinery is fairly insensitive to small variations of the machinery's operation and quite often has the appearance of a Normal or Gaussian distribution. Figure IV-14 illustrates the change in the p.d.f. before and after damage occurs in a machine.

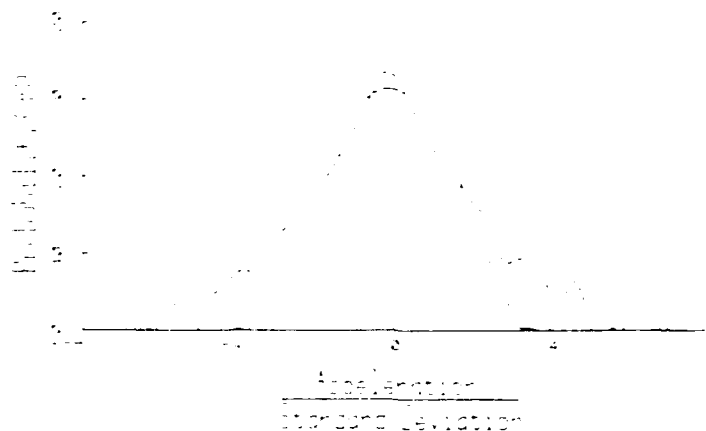

Figure IV-14. The Probability Density Function of the Normalized Acceleration of a Bearing in Good Condition (Solid Line) and after damage was inflicted (dashed line) [Ref. 47]

Braun [32] notes that the fault induced by wear follows a basic pattern. First, localized defects will appear on the component. These localized defects have an impulsive nature and will cause vibrations that will increase the high amplitude regions of the p.d.f. (the tails). As the

damage area grows, the defects become more distributed and will affect the entire p.d.f.. These changes should be reflected as changes in the parameters that describe the p.d.f.. The most common of these parameters are the mean, root mean square, and the variance and are lower order moments of the p.d.f.. Other parameters can be determined from higher order moments of the p.d.f..

One of the more popular higher order moments used in the literature is the normalized fourth moment, called kurtosis. This parameter is discussed in a handful of papers with mixed results reported on its usefulness. Dyer and Stewart [41] have shown kurtosis to be very useful in detecting bearing damage, especially when used over a series of frequency spans. Stronach et al. [18] also reported that kurtosis was extremely responsive in detecting faults in reciprocating compressors. Etbestawi and Lau [35], however, indicated the use of kurtosis was ineffective.

One of the more significant advantages of these techniques based on the p.d.f. is the large reduction in data that is handled. The techniques reduce the monitored signal down to single numbers that can be used as an indication of the machinery condition. This is a significant decrease in the amount of data compared to techniques in the frequency domain. Another advantage for techniques based on the p.d.f. is the ability to eliminate trending processes. For example, the kurtosis value for a Gaussian (or Normal) distribution is 3.0. Braun [32] suggests that this value can be used as an indicator of a healthy machine, subsequent high levels of this parameter would be indicative of a possible fault condition. A limitation of this technique is that it provides no diagnostics information.

G. Shock Pulse Measurement

Shock pulse measurement is a technique which falls under the time domain category. This technique was found in only a few of the papers reviewed, which is surprising since it is a device which is apparently on the market and appears to be successful in the detection of bearing faults.

Shock pulse measurement utilizes the impulsive nature of localized defects that was described in the previous section. Reference [32] provides a detailed description of the monitoring technique. Basically the measurement system utilizes a high frequency low damped accelerometer. The frequency cited in the reference is 30 kHz and in this frequency range there is little response from the monitored machinery. The response of this instrument to the vibration characteristics of a localized defect is a decaying sinusoidal signal. In the literature this technique has been fairly well received. Xistris and Lowe [42] indicate that at one time the Canadian Navy was considering the use of this method in its monitoring program. No follow-on reports were found.

V. NAVAL MACHINERY CONDITION MONITORING AND DIAGNOSTICS: A REVIEW OF AVAILABLE LITERATURE

A. General

As discussed in Chapter IV, vibration monitoring is widely accepted as a vehicle to determine machinery health. The current common practice indicates that machinery conditions are predicted based on the vibration measurement by a single transducer at various pick up locations (usually in radial and axial directions). For critical machineries, bi-axial and tri-axial transducers are also used. In addition to vibration data, other parameters such as temperature, pressure, flow rate, and debris are also used as diagnostic tools. Again, as mentioned before, a limited number of available literatures has been reviewed and naval approaches on machinery condition monitoring and diagnostics are discussed.

SMMSO (Submarine Monitoring Maintenance & Support Program Office) funded DTRC (David Taylor Research Center) and Tracor, Inc. in 1985-86 to study different signal processing techniques and analytical methods for analyzing vibration data [43]. During the course of this work, thirteen major vibration analysis techniques were examined: (1) signature analysis, (2) demodulation of high frequency acceleration, (3) cepstrum, (4) frequency clustering, (5) analysis of acceleration amplitude, (6) trend analysis and process modeling, (7) pattern recognition, (8) transient analysis, (9) phase-locked processing, (10) cross-sensor processing, (11) intensity measurements, (12) bispectrum and (13) Hilbert transforms. It was concluded that vibration analysis is an effective means of early detection for the majority of the problems investigated.

Monitoring machinery could consist of multiple numbers of various types of bearings, gears, shafts, impellers, valves, and so on. In many situations, signatures from one component mask signatures from another and the drastic change in response characteristics of one particular component is not detectable in the measured data and in some cases the characteristic signatures cancel each other. The dynamic responses of machinery depend on machinery mechanisms, materials involved and the

overall process loop. Without understanding the interactions of these parameters, it is difficult to evaluate the measured responses for fault detection. In addition as new machinery is developed, it is very difficult to establish the baseline data for fault detection since there is no experience with the machine. For example, among submarine-installed machineries, the turbine driven torpedo ejection pumping system is one system which is not monitored. No general monitoring scheme or diagnostic method was available for this sophisticated machinery when it was designed and reliable past measurements have yet to be established. SMMSO recognized this condition quickly and initiated a project at NPS (Naval Postgraduate School) to develop a monitoring method for this equipment with enough generality and completeness to make it acceptable for a wide range of naval machinery.

The vibration monitoring programs used by both the surface ship and submarine communities have a long history. References [42-48] provide a limited listings of available literature for anyone interested in the history of naval vibration monitoring programs. One fact is evident that any monitoring program started and maintained, even the most primitive, can be shown to materially reduce the cost of operating the equipment. However, none of these programs can detect all faults. The probability of problem detection is commonly known to be in the range between 0.77 and 0.92 [49]. A reduced percentage of problems will always exist and improved solutions to these problems can lead to increased savings and sound operating machinery. This report provides some insights into the naval approaches for machinery condition monitoring and suggests some recommendations for further improvement of the operation of the programs.

B. Naval Vibration Monitoring Programs

The major vibration monitoring program being used by the surface forces falls under the control of the Naval Sea Systems Engineering Station (NAVSSSES). This program is called the Systems and Equipment Maintenance Monitoring for Surface Ships (SEMMSS) Program. The submarine program falls under Naval Sea Systems Command (NAVSEA)

and is called the Submarine Monitoring Maintenance and Support Program Office (SMMSO). The SEMMSS and SMMSO programs are the subject of this section. Marshall[44] has described the history and procedures of the surface ship program SEMMSS in a paper published in *Naval Engineers Journal*. Although a formal written description of the submarine vibration program SMMSO is not available, references [44, 48] may be helpful.

C. Similarities within the two programs

There are many similarities between the two programs, several of these are:

(a) Both programs utilize monitoring teams to collect the vibration data from fleet units. The monitoring teams are made up of personnel that are independent of the vessel they are monitoring. These teams are given the acronym of Performance Monitoring Teams (PMT).

Submarine: The PMTs report to the submarine to perform vibration monitoring when the ship is scheduled to depart on sea trials. On occasion, surveys are performed in port when the submarines' schedule will not support additional riders. On a submarine 450-600 vibration recordings are made by the PMT during an average survey [49].

Surface Ship: The normal routine for these teams is to report to a ship early in the week to begin measurements, if the team has no major delays the survey can usually be completed within 3 days. However, an entire week is scheduled for the visit. The teams are completely equipped with all equipments needed to monitor the ship. The impact on the vessel's crew and daily routine is kept to a minimum, but ship's force is required to align and operate the machinery for the PMT. The team is responsible for recording the vibrations from a predetermined list of machines. Generally, for each machine there are at least 3 different positions that have to be monitored. If the machine is of variable speed each of these positions is monitored at each speed. There are at least 200 records of vibration readings that are taken by the PMT for each ship visited.

(b) Both the PMT utilizes accelerometers to measure the vibration produced by the machinery that is being monitored. The accelerometers used are general purpose rugged and reliable models that are made attached by the use of magnetic bases. They are placed on clean smooth discs that have been mounted on monitored machinery. The discs assure that the accelerometer is placed at the same location each time the machine is monitored. These discs are attached when the PMT first visits a ship. They are replaced by the PMT if they are missing or damaged. SMMSO accelerometers are 500 mV/g general purpose accelerometers. Reference [46] describes the evaluation of accelerometer mount transmissibility for shipboard machinery.

(c) When the survey of a shipboard machinery is completed, the vibration data recorded by the PMT is transferred to NAVSSES (surface ship) or DTRC (submarine) where the data is stored and evaluated. Vibration data are stored as frequency spectra in general. The data storage, retrieval and manipulation are done on a VAX computer system.

(d) Both programs utilize extensive machinery characteristic files that identify key frequencies which can be expected from monitored machines. The machinery characteristic files are obtained from the vendors and loaded in a relational data base. For submarine program, it is published NAVSEA S9073-AM-SBV-010/(U) SSN, SSBN. Included are physical characteristics such as the number of rolling elements in a bearing, the number of blades on an impellor, and the number of teeth on a gear. In addition, test conditions are provided.

(e) When the vibration signal data is received by NAVSSES or DTRC, the process of evaluation and reporting begins. Each of the frequency spectra that has been recorded is examined by an experienced analyst. Each of the new frequency spectra are compared to a reference spectrum and to previous spectra. Both programs utilize software to order normalize the spectra. An evaluation of the condition of the equipment is made based on changes that have occurred between the new spectrum and the reference spectrum. The analyst making this recommendation usually has several years of experience and examines the spectrum quickly and efficiently.

Complete evaluation of the recordings made on one ship may take several days. For submarine program [49], approximately 65% of vibration data is reviewed by an analyst and the computer screening filters the remaining 35%. It requires 2-3 days for an experienced analyst to review one ship set of day.

(f) Recommendations for maintenance actions are forwarded via message to the monitored ship. These recommendations range from simple actions, like closely watching the machine for future problems, to recommendations for immediate action such as complete overhaul at the earliest time possible due to impending failure. Equipment with no recommendations are assumed to be operating properly. The ship is responsible for taking corrective actions on the machinery. For submarine program, the SMMSO VMP requires formal feedback as stated in NAVSEA S9073-AM-SBV-010(U) SSN, SSBN and COMSUBLANT and COMSUBPAC INSTR 4790. Feedback is loaded into a relational data base where it is reviewed by the analyst during analysis of the vibration spectra.

D. Differences between the Two Programs

The programs have key areas where they differ:

(a) Although both programs measure the acceleration of the vibratory motion of a monitored machine, one uses velocity and the other uses acceleration. The surface program integrates the signal and uses the velocity in its evaluation of the signal. Surface program operators state that this is done in order to improve the dynamic range of the monitored signal. However, the authors believe the use of velocity in the surface program is a product of the origins of the program. In the early days of vibration monitoring velocity transducers were used in monitoring programs. These transducers were more cost effective than accelerometers and most of the recording equipment that was of reasonable cost was limited in its dynamic range. Because of this, many of the early industrial standards developed for machinery vibration limits were given in units of velocity. As the technology for recording and measuring increased in capability, acceleration became much easier to record and became cost effective. The

acceleration signal is effective across a much wider frequency range than was possible with velocity, unfortunately many of the standards have not been updated to reflect the new technology. Because of this many programs can be found that still utilize velocity. The submarine program utilizes acceleration.

(b) A second difference can be found in the training of the personnel assigned to the PMTs. The surface PMTs are composed primarily of enlisted sailors (E3-E6), with some Chief Petty Officers. The senior member of the team that comes aboard the ship is usually a Senior or Master Chief Petty Officer. On the other hand, the submarine PMT leader and assistant leader are engineer qualified LT's and LCDR's. They are hand picked as are all members of the PMT and approved personally by the Program Manager.

(c) The training that is provided to the PMT by the parent organization varies and has an impact on the quality and reliability of the data collected during a survey of a ship. The overall effectiveness of the visit may vary from ship to ship, and is very dependent on the training cycle and expertise of the PMT. The surface program provides periodic training of the PMTs. The SMMSO PMT members involved in vibration monitoring are trained by DTRC, attend factory and Navy schools and are given refresher training semiannually by DTRC and SMMSO.

(d) Both programs use the frequency spectrum of the collected data and compare it to earlier spectrum in order to see where vibration levels have changed. The magnitude of these vibration levels are then compared to a standard in order to evaluate the severity of the vibration. This severity is then used to make recommendations on repair. For submarine program, the current spectrum compares to (1) the seven previous spectra, (2) acceptance criteria, (3) maintenance criteria, and (4) data validity criteria. In Marshall's overview of the surface ship program [44], he describes the method used to establish typical levels of vibration in order to evaluate the condition of similar types of machines. He writes:

"Until recently, a variety of military standards could be applied as criteria. With the advent of computer applications to vibration analysis, statistical methods have been mandated; populations of vibration data for each individual location and machine are treated to yield mean and standard deviation values. For broad band numbers, this results in single integers which can be used as a screening tool. For narrowband spectra, the process involve manipulation of each of the 400 or more data elements which comprise each spectrum, which are then recombined to give an 'average spectrum' (mean plus one or two sigma) against which are combined current and previous spectra."

(e) The submarine program has the ability to immediately judge the quality of the just recorded spectrum. The team is trained to recognize what a good spectrum looks like and they make sure that quality data is gathered. Base line spectra for all equipments is provided to each submarine and updated when equipment has been repaired. In addition, the submarine has the capability of producing their own spectra with their installed vibration monitoring equipment. In the surface program a measurement that is faulty is not discovered until the analyst examines the data. The surface ship does not have onboard monitoring capabilities and equipments.

(f) The submarine program has the ability of using a sound silencing petty officer. This is an individual, assigned to each submarine, who has received training in monitoring machinery. This is a major advantage. Follow on measurements of equipment can be performed on the ship in order to have up-to-date status on the equipment.

(g) The Quarterly Vibration Survey Report produced by the surface monitoring program consists of prioritized maintenance actions and information on every piece of equipment measured. Included in the report are copies of spectra. The submarine program issues a message report identifying imminent problems and identifies equipment which need to be closely monitored by the ship's force. Unless otherwise requested, a spectrum of the equipment is provided to the ship only after overhaul.

E. Discussion

The past histories and experiences based on the literature reviews shows that vibration monitoring is one of the most effective approach used

as a part of preventive maintenance. Studies [50,51] have shown that regular vibration monitoring will reduce catastrophic failure rates by a factor of six when comparing monitored and non-monitored equipment.

In a typical small industrial plant the amount of equipment that is monitored is probably similar to that found on a small ship. Literature on condition monitoring indicates that a small industrial plant with a two or three man vibration team performs at least the same amount of monitoring as that done by either naval program on a single ship. This monitoring is performed with less manpower and certainly with less high powered computational capabilities. A typical industrial vibration team would have a two man staff, two or three transducers, some form of signal analyzer, a plotter, and a desk top computer to maintain records. The industrial team would be able to produce hard data indicating the amount of money the plant had saved using vibration monitoring. It could be argued that in a successful industrial program the technicians responsible for the program have been at the job for some time and have become proficient at it. However initial training for these technicians requires only about one week and then on the job training using the monitoring equipment. Navy personnel have an advantage in that the equipment installed on one ship is much the same as on any other ship. However, they are in different environments, that (1) navy ships move, and (2) shipboard machineries on several hundred ships are monitored on a quarterly basis.

F. Recommendations

(a) The two programs may combine into a single entity. This new program should start with the current systems still being used and then evolve into a organization that utilizes the best of both systems. Pooling the manpower, resources, and technology would be beneficial to all.

(b) Introduce the concept of vibration monitoring in rate training. Introduction of a maintenance concept slowly, but surely indoctrinates personnel. This familiarity with the underlying concept will help the acceptance of vibration monitoring. Along with this, more emphasis must be made to senior personnel in the surface community that success in

reducing maintenance costs can be achieved using vibration monitoring, this would include educating senior navy personnel and not just enlisted sailors just out of a school.

(c) Both programs should utilize acceleration.

(d) PMT visits should not be scheduled unless the ship is getting underway. This would eliminate many missed measurements and maximize the usefulness of the program. Technical investigation should be performed to evaluate the current "quarterly" visits. Much of the literature indicates that monthly checks on critical equipment is advisable.

(f) PMTs should be structured along the lines of the submarine program. Having senior personnel on the team gives the impression that the program is useful. The submarine program appears to be very dynamic when it comes to training. It was indicated by NAVSEA that the PMT staff of the submarine program are much more involved in the monitoring process than just taking data. An example of this can be seen in a technical manual that has been prepared for the submarine PMT's. This technical manual explains very well how to examine bearings that have been removed from machinery in order to investigate for faults. This capability makes the PMT's a valuable contributor that can be used as an asset for the fleet. Both ships-force and the parent engineering organization can benefit by having knowledgeable senior maintenance technicians available for assistance. The surface program does not have this dynamic feel to it. The members of the surface PMT have not been provided with a sense of direction. This can be seen in the fact that they are not responsible for any part of the monitoring program other than data collection. Goldman [14] points out the problem with this:

"The technician charged with carrying out the monitoring program can make it a tremendous success or a failure. The difference is in motivation. A technician who is required to simply carry vibration monitoring equipment from place to place and to press a prescribed sequence of buttons will soon realize that he can be replaced by an ape. He will begin to act accordingly."

This is not meant to demean anyone involved in the surface ship PMT's. There are very capable and motivated sailors assigned to these teams, but it illustrates a problem that can occur in any organization when the final result of actions are never seen. In order to make the program dynamic there must be a sense of purpose.

(g) Each ship in the Navy should have at least one person onboard who can perform monitoring tasks. The equipment needed to perform basic monitoring should be standard. No Chief Engineer would allow his department to go without basic handtools or lubricants. Vibration monitoring should be looked at as another tool to get the job done.

(h) Each program should use common equipment. The submarine program utilizes the CSI model 2110 machinery analyzer, produced by Computational Systems Inc.. This piece of equipment is a fairly low cost, off the shelf component that is excellent for the monitoring that is currently being performed by the Navy. The surface ship program is utilizing the Digital Vibration Survey Instrument, Model DI-303, by Dynamic Instruments, Inc. This instrument was designed by the NAVSSES and is higher in cost. The current state of the art in Signal Analyzers is outstanding and the price is reasonable. The ability of the surface Navy to find a system off the shelf at a reasonable cost may be a problem, but may be attributed to the use of velocity and order normalized spectra.

(i) Research into more effective fault automatic detection systems that monitor critical equipment should be continued and expanded as time and budget permit.

(m) Results from vibration monitoring and results from other fault detection schemes should be correlated routinely. Vibration monitoring is a good but not a flawless method of machine condition monitoring. Combining results of vibration monitoring with results from an oil monitoring program produce improved information on the condition of a piece of equipment. Additional research to develop inexpensive analyses of greases should be conducted in order to locate bearing problems early.

(n) Aircraft carriers should be made a part of the naval monitoring program. Currently these ships are monitored by DLI, an outside civilian contractor.

VI. CONCLUDING REMARKS

A. Summary

This review of machinery condition monitoring and diagnostics was conducted with submarine applications in mind. There are a significant number of publications on machinery condition monitoring and diagnostics available, however very few specify submarine applications. This may be attributed to the classified nature of submarines, but is not a major problem since monitoring a pump, or any piece of machinery, is the same whether on a submarine or elsewhere. The purpose of conducting this survey was not to include a review of all publications, but to understand the current status and to identify future base technology needs.

Machinery maintenance programs have been categorized into three broad groups: crisis maintenance, preventive maintenance, and predictive maintenance. The first two categories focus on unmonitored machineries and the last on monitored machineries. Condition monitoring is the technique used in a predictive maintenance program to detect and diagnose a fault.

The goals of machinery monitoring and diagnostics include: detecting faults, identifying faults, and anticipating the breakdown of machinery.

The techniques for machinery condition monitoring were broadly divided into six groups: aural, visual, operational variable, temperature, wear debris, and vibration monitoring. Each group and the current status of their use in condition monitoring was reviewed. The results of the survey indicate that several techniques may be equally effective in monitoring the machinery condition. The final choice is dependent upon the type of machinery and the resources available. Frequently a combination of techniques is desired.

Currently the vibration and noise generated by a piece of machinery is the primary signal used to reveal its machinery condition. One important idea to keep in mind is that machinery diagnostics and noise reduction goals are different. A machine operating properly and without faults may be very noisy, while a machine that has developed a major fault may operate quietly. For submarines radiated noise is a major concern. Even though the goals of the programs may be different, machinery diagnostics and noise reduction efforts may be combined. Equipment used for machinery diagnostics may also be used to indicate radiated noise levels and to identify the source of the noise.

Vibration monitoring analysis methods have been grouped into time, frequency, and quefreny domains. The change in vibration amplitude level has been used as a measure of machinery condition. A single transducer has been widely used to collect the vibration signals. Probability-based analysis, such as mean, variance and kurtosis, also provides some insight into the machinery condition.

Surface ship and submarine vibration monitoring programs were compared and recommendations were made to improve the maintenance programs. One far reaching recommendation was that the two programs could be combined into a single entity which utilized the best of both systems. Another recommendation was that results of the vibration monitoring program should be combined with the results of other programs, such as oil analysis, thereby producing more accurate and useful information on machinery condition.

B. Future Research Areas

(1) Vibration, noise, pressure fluctuations, temperature and other parameters are all interrelated and must be considered together in the process of determining the health of a machine. There is a need for improved monitoring schemes to take these interrelations into account.

(2) The common practice in vibration monitoring is to measure machinery vibration in one direction at a time. The measured data is processed further for fault detection. It is proposed to investigate the use of multiple sensors and their measurements to identify and evaluate the machinery condition qualitatively.

(3) A study of the correlation between acoustic noise and vibration data by temporal waveform, frequency spectrum, phase spectrum, coherence and correlation functions should be conducted.

(4) A methodology for monitoring transient signals should be developed. A specific application is the submarine torpedo ejection pump.

(5) Most diagnostics and monitoring systems are based on empirical procedures. In this approach there may be no clear reason why a particular characteristic of the measured signal should be identifiable with a particular fault, or the relationship may be largely intuitive. An analytical approach needs to be sought to determine the various properties of the event that produces the disturbance in the machine. Source identification problems need to be studied to define the source-path-radiation or excitation-transmission-vibration relations to reduce the levels of disturbance in the machine. The fault-related vibration generation and transmission process needs to be studied in detail to be able to design improved diagnostic systems to detect and recover the appropriate signatures.

(6) Condition monitoring of reciprocating machinery is difficult due to the complicated nature of the machinery. There are a few reports on monitoring of reciprocating machinery in the literature, but additional in-depth studies are needed. A specific application is the High Pressure Air Compressor.

(7) A single reference with specific examples of signatures produced by various machinery components needs to be published. In addition to base line signatures, common faults should be shown.

ACKNOWLEDGEMENTS

Authors wish to express their sincere appreciation to Mr. Alan Pride, Project Manager, Submarine Noise and Vibration Monitoring, PMS 390TN, NAVSEA for his critical comments and inputs on submarine vibration monitoring discussed in Chapter V, and also to Mr. Bruce Marshall for his cooperation and assistance to understand the current practice of vibration monitoring of shipboard machineries for surface ship.

Authors also wish to express their gratitude to Visiting Professor Glenn Reid and Professor Paul Pucci for their continuous support, discussions and review of original manuscripts. This project gave us the whole insight into the world of machinery condition monitoring and diagnostics. This project would not have been possible without funding from DARPA. Many thanks to DARPA Program Manager, LCDR Richard Martin, USN for his patience.

REFERENCES

1. Strunk, W. D., "Considerations for the Establishment of a Machinery Monitoring and Analysis Program for Surface Ships of the U. S. Navy," Proceedings of the 6th International Modal Analysis Conference, Vol. II, February 1988, pp. 914-920.
2. Stamm, J. A., Machinery Diagnostics Via Mechanical Vibration Analysis Using Spectral Analysis Techniques, Master's Thesis, Department of Mechanical Engineering, Naval Postgraduate School, Monterey, California, September 1988.
3. Mathew, J., "Machine Condition Monitoring Using Vibration Analyses," Acoustics Australia, v. 15, April 1987, pp. 7-13.
4. Stewart, R. M., "Machinery Management Based on the Application of Modern Diagnostics, Control Theory and Artificial Intelligence", Condition Monitoring '84: Proceedings of an International Conference on Condition Monitoring, Swansea, U.K., April 10-13 1984, pp. 32-54.
5. Angelo, M., "Vibration Monitoring of Machines," B & K Technical Review, n. 1, 1987, pp. 1-36.
6. Machine Health Monitoring, B & K , 1984.
7. McCord, R., and Smith, M., "The Effects of an Engine Condition Monitoring Program on an Aging Bomber and Tanker Fleet," Time-Dependent Failure Mechanisms and Assessment Methodologies, Proceedings of the 35th Meeting of the Mechanical Failures Group, National Bureau of Standards, Gaithersburg, Maryland , 20-22 April 1982, pp. 218-228.

8. Eissenberg, D., "Nuclear Plant Aging Research Program Objectives and Scope," Proceedings of the 40th Meeting of the Mechanical Failures Prevention Group, 1985, pp. 5-14.
9. Edman, T., Harp, S., Mitchell, D., and Hadden, G., "A Knowledge-Based System for Preventive Maintenance," Proceedings of the 40th Meeting of the Mechanical Failures Prevention Group, 1985, pp. 361- 368.
10. Krieger, D., "AI Concepts Applied to ATE Software," Proceedings of the 40th Meeting of the Mechanical Failures Prevention Group, 1985, pp. 17-23.
11. Herricks, D.M., and Strunk, W.D., "On-line Vibration Monitoring and Analysis System at the Paducah Gaseous Diffusion Plant," Proceedings of the 6th International Modal Analysis Conference, January 1988, pp. 908-913.
12. Reason, J., "Continuous Vibration Monitoring Moves into Diagnostics," Power, January 1987, pp. 47-51.
13. Lyon, R., "The Monitoring and Diagnostics of Machines and Processes," Proceedings of the 1st International Machinery Monitoring and Diagnostics Conference and Exhibit, September 1989, pp. xi-xiii.
14. Goldman, S., "Periodic Machinery Monitoring: Do It Right," Hydrocarbon Processing, August 1984, pp. 51-56.
15. Stewart, R. M., "A Systematic Approach to Automating Machinery Management", Sound and Vibration, v.19, n.6, June 1985, pp. 14-23.
16. Cempel, C., "The Tribovibroacoustical Model of Machines," Wear, v. 105, n. 4, 1985, pp. 297-305.

17. Hadden, S., and Maurer, J., "Predicting Failure Using an On-Board Monitoring System," Time-Dependent Failure Mechanisms and Assessment Methodologies, Proceedings of the 35th Meeting of the Mechanical Failures Group, National Bureau of Standards, 20-22 April 1982, pp. 229-236.
18. Stronach, A., Johnston, A., and Cudworth, C., "Detection of Valve Faults on Reciprocating Compressors," Condition Monitoring '84, Proceedings of an International Conference on Condition Monitoring, Swansea, U.K., 10-13 April 1984, pp. 293-304.
19. Kuhnell, B., and Stecki, J., "Correlation of Vibration, Wear Debris Analysis and Oil Analysis in Rolling Element Bearing Condition Monitoring," Condition Monitoring '84, Proceedings of an International Conference on Condition Monitoring, Swansea, U.K., 10-13 April 1984, pp. 205-220.
20. Gulyas, M., "Testing Gear-Drives by Measuring Their Tribotechnic Parameters," Condition Monitoring '84, Proceedings of an International Conference on Condition Monitoring, Swansea, U.K., 10-13 April 1984, pp. 688-702.
21. Goldman, S., "Vibration Analysis now Works on Reciprocating Engines," Power, August 1987, pp. 47-56.
22. Charbonneau, A., "Update on Field Signature Testing of Motor Operated Valve Mechanical and Electrical Degradations," Proceedings of the 40th Meeting of the Mechanical Failures Prevention Group, National Bureau of Standards, 1985, pp. 412-415.
23. Reason, J., "Pinpoint Induction Motor Faults by Analyzing Load Current," Power, October 1987, pp. 87-88.
24. Verbrugge, E., "On-Line Acoustical Leak Detection on Feed-Water Heaters," Time-Dependent Failure Mechanisms and Assessment Methodologies, Proceedings of the 35th Meeting of the Mechanical

- Failures Group, National Bureau of Standards, 20-22 April 1982, pp. 175-180.
25. Czichos, H., Tribology. Elsevier/North-Holland Inc., New York, 1979.
 26. Milder, F., and Sioshansi, P., "Continuous Real-Time Wear Monitoring For Prevention of Catastrophic Failure," Time-Dependent Failure Mechanisms and Assessment Methodologies, Proceedings of the 35th Meeting of the Mechanical Failures Group, National Bureau of Standards, 20-22 April 1982, pp. 155-164.
 27. Jarvis, N., Wohltjen, H., Mowery, R.L., Snow, A.W., Giuliani, J.F., and Barger, W.R., "Chemical Microsensors in Lubrication and Tribology," Condition Monitoring '84, Proceedings of an International Conference on Condition Monitoring, Swansea, U.K., 10-13 April 1984, pp. 674-687.
 28. Blatchley, C., and Sioshansi, P., "Millisecond Bearing Wear: Surface Layer Activation in a Gas Turbine Engine," Proceedings of the 40th Meeting of the Mechanical Failures Prevention Group, National Bureau of Standards, 1985, pp. 136-143.
 29. "Dynamic Signal Analyzer Applications," Hewlett-Packard Company, Application Note 243-1, 1983.
 30. Lyon, R.H., Machinery Noise and Diagnostics, Butterworth Publishers, Stoneham, MA, 1987.
 31. Smith, J. D., Gears and Their Vibrations, Marcel Dekker, Inc., New York, 1983.
 32. Braun, S., Editor, Mechanical Signature Analysis, Academic Press Inc., Orlando, FL, 1986.

33. Brown, D. N., "Machine-Condition Monitoring Using Vibration Analysis: a Case Study from a Nuclear Power-Plant," Bruel and Kjaer Application Notes.
34. Randall, R.B., "Computer Aided Vibration Spectrum Trend Analysis for Condition Monitoring," *Maintenance Management International*, v. 5, 1985, pp. 161-167.
35. Elbestawi, M., and Lau, D., "An Assessment of Some Signature Analysis Techniques Used in Vibration Monitoring of Rotating Machinery," *Time-Dependent Failure Mechanisms and Assessment Methodologies*, Proceedings of the 35th Meeting of the Mechanical Failures Group, National Bureau of Standards, Gaithersburg, Maryland, 20-22 April 1982, pp. 195-203.
36. McFadden, P. D., "Examination of a Technique for the Early Detection of Failure in Gears by Signal Processing of the Time Domain Average of the Meshing Vibration," *Aero Propulsion Technical Memorandum 434*, Australian Department of Defense, 1986.
37. Stewart, R. M., "Application of Signal Processing Techniques to Machinery Health Monitoring," Noise and Vibration, edited by White, R.G., and Walker, J.G., John Wiley & Sons, New York, 1982, Chapter 23.
38. Childers, D.G., Skinner, D.P. and Kemerait, R.C., "The Cepstrum: A guide to Processing," Proceedings of the IEEE, vol. 65, Oct. 1977, pp. 1428-1443.
39. Harris, C.M., Editor, Shock and Vibration Handbook, McGraw Hill Book Company, New York, 1987.
40. Alfredson, R. J., and Mathew, J., "Time Domain Methods for Monitoring the Condition of Rolling Element Bearings," *The*

Institution of Engineers. Australia. Mechanical Engineering Transactions, No. 2, July 1985, pp 102-107.

41. Dyer, D., and Stewart, R., "Detection of Rolling Element Bearing Damage by Statistical Vibration Analysis," Transactions of the ASME, Journal of Mechanical Design, v. 100, no. 2, April 1978, pp. 229-235.
42. Xistris, G. D., and Lowe, J. M., "On the Effectiveness of Maintenance Programs and Policies for Shipboard Machinery," Condition Monitoring '84, Proceedings of an International Conference on Condition Monitoring, Swansea, U.K., 10-13 April 1984, pp. 55-66.
43. Tracor Applied Sciences, "Advanced Vibration Analysis Studies," Tracor Documt No.: T86-01-9567-U, Dec. 1986.
44. Marshall, B.R., "A Surface Navy Vibration Program Overview: Standardization and State-of-the-Art," Naval Engineers Journal, vol. 100, May 1988, pp. 90-100.
45. Milner, G. M., Leach, J., and Smith, R., "Development of an Automatic Machinery Vibration Analysis (AMVA) System," Detection, Diagnosis and Prognosis of Rotating Machinery to Improve Reliability, Maintainability, and Readiness through the Application of New and Innovative Techniques, Proceedings of the 41st Meeting of the Mechanical Failures Prevention Group, Patuxent River, Maryland, 28-30 October 1986, pp. 237-248.
46. Chapman, C. L., and Jolley, R., "Systems and Equipment Maintenance Monitoring for Surface Ships (SEMMSS) Program," Naval Engineers Journal, v. 99, November 1987, pp. 63-69.

47. Strunk, W.D., "The Evaluation of Accelerometer Mount Transmissibility for U.S. Navy Applications," Proceedings of the 6th International Modal Analysis Conference, January 1988, pp 1384-1389.
48. Tracor Applied Sciences, "An Analysis of Submarine Machinery Vibration Monitoring," Tracor Documt No.: T89-01-9546-U, May 1986.
49. Program Manager of SMMSO, "A Review of NPS 69-90-03, Submarine-Installed Machinery Monitoring and Diagnostics: A State-of-the Art Review," November 27 1990.
50. Tracor Applied Sciences, "Submarine Monitoring, Maintenance [and] Support Program Office (SMMSO) Vibration Program Performance Quantification," Tracor Documt No.: T86-9566-V, Dec. 1986.
51. DTRC Report No. DTNSTDC/SME-85/45, June 1985 .

BIBLIOGRAPHY

Alfredson, R. J., and Mathew, J., "Time Domain Methods for Monitoring the Condition of Rolling Element Bearings," The Institution of Engineers, Australia, Mechanical Engineering Transactions, July 1985, pp 102-107.

Bently, D., Zimmer, S., Palmatier, G. E., and Mosgynsha A., "Interpreting Vibration Information from Rotating Machinery," Noise and Vibration Control Worldwide, v. 7, Jan 1986, pp 174-176.

Braun, S., "Mechanical Signature Analysis (MSA) at the 8th Vibration Conference," Transactions of the ASME, Journal of Mechanical Design, v. 104, April 1982, pp 252-258.

Bruan, S., Mechanical Signature Analysis, Academic Press Inc., Orlando, FL, 1986.

Braun, S., "MSA-Mechanical Signature Analysis," Journal of Vibration, Acoustics, Stress, and Reliability in Design, v.106, Jan 1984, pp 1-3.

Camboulives, J., "Turbo-Generators Surveillance by use of Statistical Techniques," Time-Dependent Failure Mechanisms and Assessment Methodologies, Proceedings of the 35th Meeting of the Mechanical Failures Group, National Bureau of Standards, Gaithersburg, Maryland, 20-22 April 1982, pp. 185-194.

Chapman, C. L., and Jolley, R., "Systems and Equipment Maintenance Monitoring for Surface Ships (SEMMSS) Program," Naval Engineers Journal , v. 99, November 1987, pp. 63-69.

Chevroulet, G., "Vibration Monitoring of Hydro Machinery," International Water Power and Dam Construction, v. 39, October 1987.

Dyer, D., and Stewart, R., "Detection of Rolling Element Bearing Damage by Statistical Vibration Analysis," Transactions of the ASME, Journal of Mechanical Design, v. 100, No. 2, April 1978, pp. 229-235.

Edman, T., Harp, S., Mitchell, D., and Hadden, G., "A Knowledge-Based System for Preventive Maintenance," Proceedings of the 40th Meeting of the Mechanical Failures Prevention Group, 1985, pp. 361-368.

El Sayed, A. E., "Knowledge Based Systems for Machinery Fault Diagnosis," Proceedings of the 6th International Modal Analysis Conference, January 1988, pp. 1230-1237.

Elbestawi, M., and Lau, D., "An Assessment of Some Signature Analysis Techniques Used in Vibration Monitoring of Rotating Machinery," Time-Dependent Failure Mechanisms and Assessment Methodologies, Proceedings of the 35th Meeting of the Mechanical Failures Group, National Bureau of Standards, Gaithersburg, Maryland, 20-22 April 1982, pp. 195-203.

Eissenberg, D., "Nuclear Plant Aging Research Program Objectives and Scope," Proceedings of the 40th Meeting of the Mechanical Failures Prevention Group, 1985, pp. 5-14.

Freeman, R., "Use of Computers for Non-Destructive Testing and Condition Monitoring in Aerospace," Condition Monitoring '84, Proceedings of an International Conference on Condition Monitoring, Swansea, U.K., 10-13 April 1984, pp. 67-85.

Gadd, P., and Mitchell, P. J., "Condition Monitoring of Helicopter Gearboxes Using Automatic Vibration Analysis Techniques," AGARD Conference Proceedings, No. 369, pp. (29-1)-(29-10).

Hadden, S., and Maurer, J., "Predicting Failure Using an On-Board Monitoring System," Time-Dependent Failure Mechanisms and Assessment Methodologies, Proceedings of the 35th Meeting of the

Mechanical Failures Group, National Bureau of Standards, Gaithersburg, Maryland, 20-22 April 1982, pp. 229-236.

Kincaid, W. S., "Automated Data Acquisition, Accumulation and Assessment in Equipment Condition Monitoring Through Lubricant Analysis," Time-Dependent Failure Mechanisms and Assessment Methodologies, Proceedings of the 35th Meeting of the Mechanical Failures Group, National Bureau of Standards, Gaithersburg, Maryland, 20-22 April 1982, pp. 165-174.

Krieger, D., "AI Concepts Applied to ATE Software," Proceedings of the 40th Meeting of the Mechanical Failures Prevention Group, 1985, pp. 17-23.

Kuhnell, B., and Stecki, J., "Correlation of Vibration, Wear Debris Analysis and Oil Analysis in Rolling Element Bearing Condition Monitoring," Condition Monitoring '84, Proceedings of an International Conference on Condition Monitoring, Swansea, U.K., 10-13 April 1984, pp. 205-220.

Lyon, R.H., Machinery Noise and Diagnostics, Butterworth Publishers, Stoneham, MA, 1987.

Marshall, B. R., "A Surface Navy Vibration Program Overview: Standardization and State-of-the-Art," Naval Engineer's Journal, vol. 100, May 1988, pp. 90-100.

Mathew, J., and Alfredson, R. J., "The Condition Monitoring of Rolling Element Bearings Using Vibration Analysis," Transactions of the ASME, Journal of Vibration, Acoustics, Stress, and Reliability in Design, v. 106, July 1984, pp.447-453.

Meher-Homji, C., "Reasoning Foundations for Machinery Diagnostics-Thought Process and Expert Systems," Proceedings of the 40th Meeting of the Mechanical Failures Prevention Group, 1985, pp. 17-23.

Milner, G. M., Leach, J., and Smith, R., "Development of an Automatic Machinery Vibration Analysis (AMVA) System," Detection, Diagnosis and

Prognosis of Rotating Machinery to Improve Reliability, Maintainability, and Readiness through the Application of New and Innovative Techniques, Proceedings of the 41st Meeting of the Mechanical Failures Prevention Group, Patuxent River, Maryland, 28-30 October 1986, pp. 237-248.

Reif, Z., Lai, M., and Silvaggi, C., "Detection of Bearing Failures by Means of Vibration," Proceedings of the 6th International Modal Analysis Conference, January 1988, pp 1238-1242 .

Renwick, J., "Condition Monitoring of Machinery Using Computerized Vibration Signature Analysis," IEEE Transactions on Industry Applications, v. IA-20, May 1984, pp. 519-527.

Shock and Vibration Handbook, C.M. Harris, Ed., McGraw-Hill Book Company, New York, 1987.

Smiley, R., and Schiltz, R., "Machinery Monitoring for the Factory of the Future," Proceedings of the 40th Meeting of the Mechanical Failures Prevention Group, 1985, pp. 17-23.

Stewart, R.M., "The Specification and Development of a Standard for Gearbox Monitoring," Second International Conference; Vibrations in Rotating Machinery (1980), Institution of Mechanical Engineers, 1-4 September 1980, pp 353-358.

Toyota, T., Maekawa, K., and Nakashima, S., "Automatic Equipment Diagnosis Using Fuzzy Logic," Proceedings of the 40th Meeting of the Mechanical Failures Prevention Group, 1985, pp. 73-82.

Waldes, P., and Lungarten, J., "Are Maintenance Expert Systems Practical Now?," Proceedings of the 40th Meeting of the Mechanical Failures Prevention Group, 1985, pp. 353-360.

Wang, S. S., "Artificial Intelligence and Expert Systems in Modal Analysis and Design," Proceedings of the 6th International Modal Analysis Conference, January 1988, pp. 1730-1736.

Xistris, G. D., and Loewe, J. M., "On the Effectiveness of Maintenance Programs and Policies for Shipboard Machinery," Condition Monitoring '84, Proceedings of an International Conference on Condition Monitoring, Swansea, U.K., 10-13 April 1984, pp.55-66.