

1

AD-A237 634



DTIC

JUL 08 1991

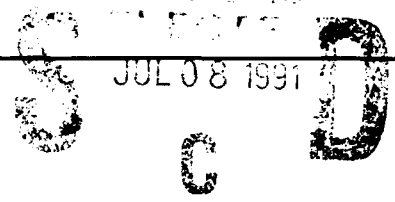

Research and Development Technical Report
SLCET-TR-91-17

A Calorimetric Investigation of Deuterated Palladium Electrodes

T. Richard Jow, Steven Slane, Edward J. Plichta,
Charles W. Walker, Jr. and Sol Gilman

Electronics Technology and Devices Laboratory

May 1991

DISTRIBUTION STATEMENT
Approved for public release.
Distribution is unlimited.

| | |
|--------------------|-------------------------------------|
| Approval For | |
| DTIC Tab | <input checked="" type="checkbox"/> |
| Unprocessed | <input type="checkbox"/> |
| Justification | |
| By _____ | |
| Distribution | |
| Availability Codes | |
| Dist | Special |
| A-1 | |

U. S. ARMY LABORATORY COMMAND
Electronics Technology and Devices Laboratory
Fort Monmouth, NJ 07703-5000



91-04304



NOTICES

Disclaimers

The findings in this report are not to be construed as an official Department of the Army position, unless so designated by other authorized documents.

The citation of trade names and names of manufacturers in this report is not to be construed as official Government indorsement or approval of commercial products or services referenced herein.

REPORT DOCUMENTATION PAGE

Form Approved
OMB No. 0704-0188

Public reporting burden for this collection of information is estimated to average 1 hour per response, including the time for reviewing instructions, searching existing data sources, gathering and maintaining the data needed, and completing and reviewing the collection of information. Send comments regarding this burden estimate or any other aspect of this collection of information, including suggestions for reducing the burden, to Washington Headquarters Service, Directorate for Information Operations and Reports, 1215 Jefferson Davis Highway, Suite 1204, Arlington, VA 22202-4302, and to the Office of Management and Budget, Paperwork Reduction Project (0704-0188), Washington, DC 20503.

| | | | |
|--|---|--|---|
| 1. AGENCY USE ONLY (Leave blank) | 2. REPORT DATE May 1991 | 3. REPORT TYPE AND DATES COVERED Technical Report; Apr 89 - Sep 89 | |
| 4. TITLE AND SUBTITLE A CALORIMETRIC INVESTIGATION OF DEUTERATED PALLADIUM ELECTRODES | | 5. FUNDING NUMBERS PE: 1L1 PR: 611102 WU: H47 | |
| 6. AUTHOR(S) T. Richard Jow, Steven Slane, Edward J. Plichta, Charles W. Walker, Jr., and Sol Gilman | | | |
| 7. PERFORMING ORGANIZATION NAME(S) AND ADDRESS(ES) U.S. Army Laboratory Command (LABCOM) Electronics Technology and Devices Laboratory (ETDL) ATTN: SLCET-PR Fort Monmouth, New Jersey 07703-5000 | | 8. PERFORMING ORGANIZATION REPORT NUMBER SLCET-TR-91-17 | |
| 9. SPONSORING / MONITORING AGENCY NAME(S) AND ADDRESS(ES) | | 10. SPONSORING / MONITORING AGENCY REPORT NUMBER | |
| 11. SUPPLEMENTARY NOTES | | | |
| 12a. DISTRIBUTION / AVAILABILITY STATEMENT Approved for public release; distribution is unlimited. | | 12b. DISTRIBUTION CODE | |
| 13. ABSTRACT (Maximum 200 words) Calorimetric experiments were conducted to verify the caloric claims by Fleischmann and Pons. A twin-cell heat conduction calorimeter was used, rather than the quasi-adiabatic instrumentation of the original investigation. Under similar electrochemical conditions, the output of heat powers from experimental cells of Pd in 0.1 M LiOD/D ₂ O and that from control cells of Pd in 0.1 M LiOH/H ₂ O and Pt in 0.1 M LiOD/D ₂ O were all in close agreement with input heat powers using simple theory. These results show no anomalous "excess" heat, as claimed. | | | |
| 14. SUBJECT TERMS conduction calorimeter; calorimetry; palladium deuterium | | 15. NUMBER OF PAGES 21 | |
| | | 16. PRICE CODE | |
| 17. SECURITY CLASSIFICATION OF REPORT Unclassified | 18. SECURITY CLASSIFICATION OF THIS PAGE Unclassified | 19. SECURITY CLASSIFICATION OF ABSTRACT Unclassified | 20. LIMITATION OF ABSTRACT UL |

CONTENTS

| | Page |
|---|------|
| INTRODUCTION..... | 1 |
| EXPERIMENTAL..... | 2 |
| Electrochemical cells..... | 2 |
| Calorimetry..... | 2 |
| Determination of excess heat power..... | 5 |
| Determination of D/Pd..... | 7 |
| RESULTS AND DISCUSSION..... | 7 |
| SUMMARY..... | 11 |
| ACKNOWLEDGMENTS..... | 16 |
| REFERENCES..... | 16 |

FIGURES

| | |
|---|-------|
| 1. Cell configurations..... | 3 |
| 2. Schematic view of Hart Scientific twin-cell heat conduction calorimeter..... | 4 |
| 3. Percent of excess heat power (%) as a function of time in a day for Pd in 0.1 M LiOD/D ₂ O at current densities of 60 and 240 mA/cm ² in glass cell..... | 8 |
| 4. Percent of excess heat power (%) as a function of time in glass cells..... | 9, 10 |
| 5. Percent of excess heat power (%) as a function of time in stainless steel cells..... | 12-14 |

TABLES

| | |
|---|----|
| 1. Sample calorimeter calibration run..... | 6 |
| 2. Average percent excess heat power of experimental and control cells..... | 15 |

INTRODUCTION

It was reported by Fleischmann and Pons¹ that nuclear radiation and anomalous excess heat were observed when electrochemically incorporating deuterium atoms into a cathodically polarized palladium (Pd) electrode. If this is confirmed, it could have an important impact on the Nation's power supply. We have been conducting experiments to attempt to verify the caloric claims under similar electrochemical conditions, but by using a different calorimetric approach.

The calorimetric method used by the original investigators was quasi-adiabatic calorimetry. Conventional adiabatic calorimetry is suitable for short-term measurements where there is negligible leakage of heat from the experiment. Under those conditions, the quantity of released heat is determined from the corresponding linear temperature increase after experimental determination of the proportionality constant, i.e., the total heat capacity of cell and contents. If adiabatic instrumentation is used for long-term experiments, the resulting quasi-adiabatic steady-state temperature rise reflects a complex balance between heat generation and dissipation. Although the method can be calibrated experimentally, it is generally very sensitive to such experimental conditions as the placement of the thermocouple, the rate of stirring of electrolyte, and the temperature and agitation of the external bath. In addition, in this particular case, there are potential sources of error corresponding to evolution of gases and evaporation of D₂O.

Recently, Appleby et al.² reported 10-15 percent excess heat from Pd with a diameter of 0.5 mm at a current density of 600 mA/cm² by using a heat conduction calorimeter. Instead of a glass container, which Fleischmann and Pons¹ preferred, they used a stainless steel cell container.

In this paper, we report the heat outputs from cells with both glass and stainless steel containers. We employed a twin-cell heat conduction calorimeter, as did Appleby, et al.,² since it is more suitable for long-term measurements than the quasi-adiabatic approach. The cells comprised a deuterated Pd cathode and a Pt anode in a solution of lithium deuterioxide (LiOD) in deuterium oxide (D₂O). The control cells comprised either a Pd cathode in a solution of lithium hydroxide (LiOH) in water (H₂O) or a Pt cathode in a solution of LiOD in D₂O.

EXPERIMENTAL

Electrochemical cells

Two types of cells were used in this work. The first, shown in Fig. 1(a), was made of a plain glass vial with a Teflon stopper that served as an electrode holder. A one millimeter diameter hole in the stopper allowed the release of gases that were produced during electrolysis. The second type, shown in Fig. 1(b), was made of a stainless steel can (316 L) with a Teflon stopper, but without a hole. The gases were able to exit through the fissure between the wall of the can and the Teflon holder, and through the fissure between the Pt leads and the Teflon holder. In the glass cells, Pd wires were used which were 25 mm long X 1 mm in diameter (Englehard). In the stainless steel cells, Pd wires 10 mm long X 0.5 mm in diameter (99.997%, Johnson Matthey) were used. In most measurements, before using the as-received wires, they were rinsed in ethanol, distilled H₂O, and D₂O. In some measurements, the Pd wires were heat-treated for four hours at 1140 °C under vacuum before use. A platinum wire that was spot-welded on Pd was employed as a lead from Pd to the outside of the cell. In the stainless steel cell, the Pt lead wire was wrapped with Teflon tape to prevent it from exposure to the electrolyte. In the glass cell, a Pt gauze was used for anode; a helically wound Pt wire was utilized in the stainless steel cell.

The electrolyte solution of 0.1 M LiOD in D₂O was prepared by dissolving the appropriate amount of Li in D₂O (D₂O, 99.08%, ICN Biomedicals, Inc., used as received). A 0.1 M solution of LiOH in H₂O (deionized and distilled) was prepared similarly.

Calorimetry

A commercially available Hart Scientific Model 7709 heat-conduction calorimeter was used to measure the heat output from the cells. This calorimeter is based on the Seebeck, or thermocouple, effect, in which a voltage is produced proportional to the temperature difference across the thermoelectric devices (TED). The temperature difference, and hence the voltage generated across the TED, is directly proportional to the heat-flow from the cell measured. Thus, by knowing the amount of voltage generated, the amount of heat can be calculated. Figure 2 is a schematic of the basic calorimeter design, which consists of twin measuring cells mounted to TED, which in turn are mounted to a large aluminum block. This unit is then submerged in a constant-temperature water bath. The aluminum block acts as a heat sink

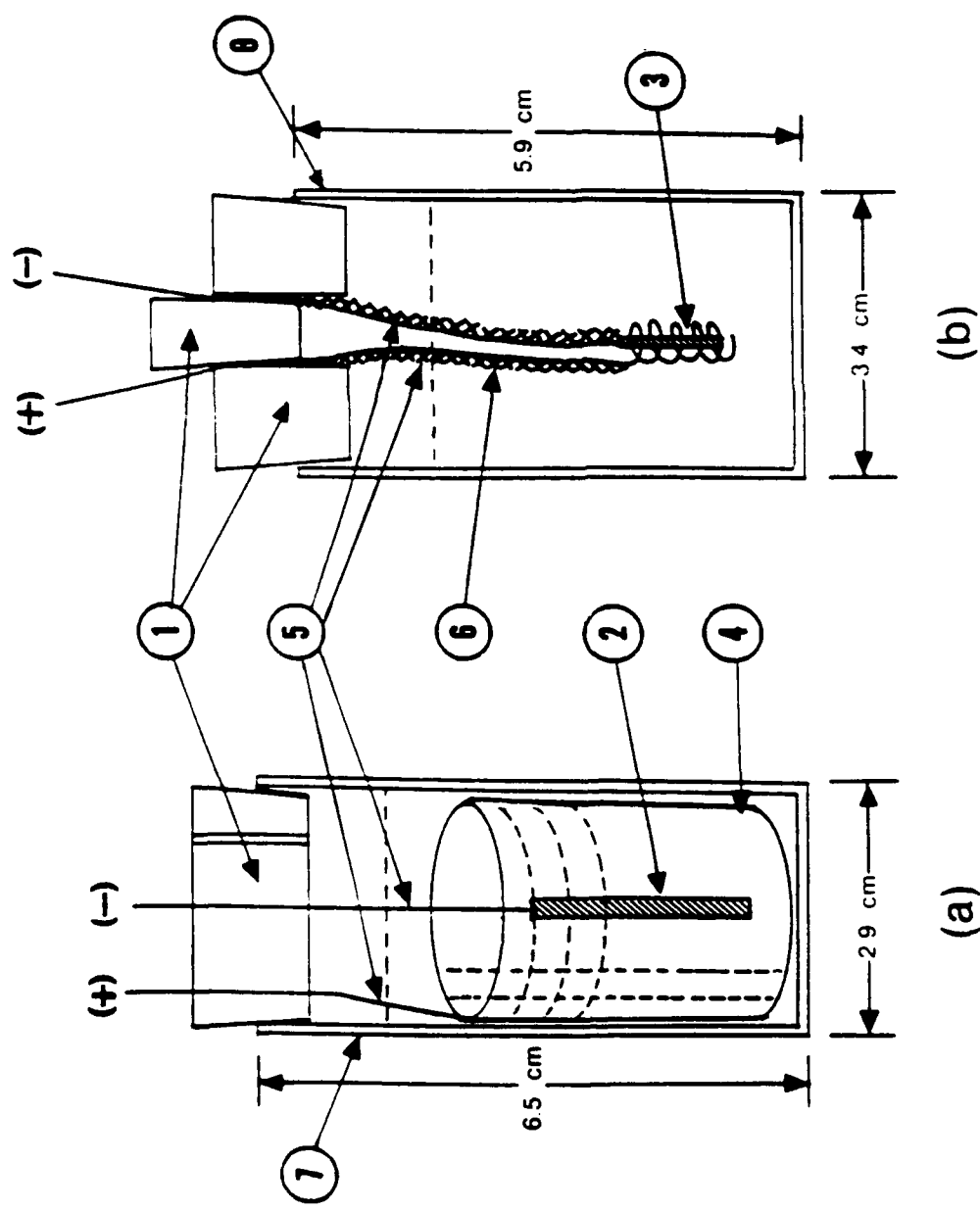

1. Teflon holder
2. Pd electrode
3. Pd electrode
4. Pt gauze
5. Pt wire
6. Teflon tape
7. Glass vial
8. Stainless steel can

(a) (b)

Figure 1. Cell configurations: (a) glass cell; (b) stainless steel cell.

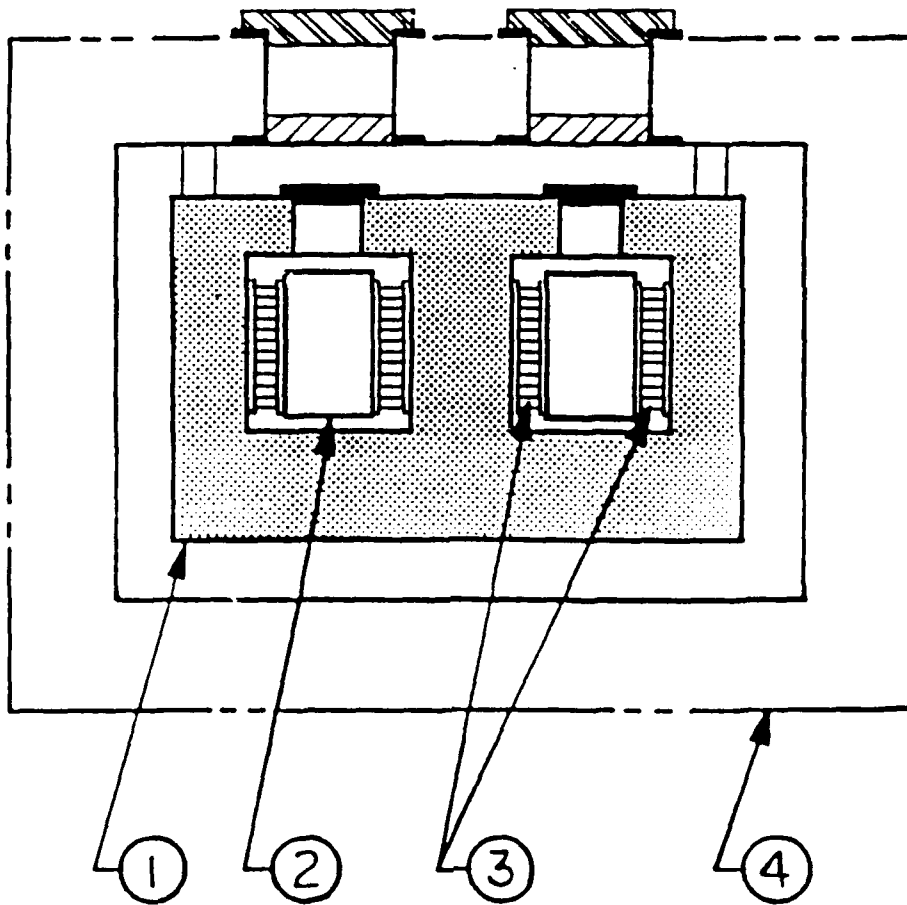

1. Aluminum heat sink
2. Cell
3. Thermoelectric sensors
4. Stable temperature environment

Figure 2. Schematic view of Hart Scientific twin-cell heat conduction calorimeter.

with a stable temperature. When a temperature change occurs in a measuring cell, heat either flows into or out of the heat sink through the TED, which generates a voltage that is then recorded. The twin-cell design has an advantage of canceling extraneous thermal effects. If the heat sink drifts up in temperature, a small amount of heat will flow into the cells through TED and cause an output voltage. However, the cells are connected in a differential fashion; thus, the difference output voltage is reduced by an order of magnitude or more, and results in the long-term stability and reproducibility of the baseline. This method offers the capability of measuring the heat rate of micro-watts to watts with proper design, is heat-capacity insensitive, and is suitable for long-term measurement.

Calibration was performed as follows. A cell containing a 10.37 ohm resistor that had been dipped in Dow Corning silicone oil in a stainless steel can was used to provide a known heat power, which is the product of the voltage across the cell times the current. The calibrations were at heat power of 10, 66, 264, and 670 mW. The corresponding voltages across TED were used to calculate the calibration constant C W/V, which is believed to be accurate to two percent, based on the accuracy of the calibration constant. The results of a sample calibration run are shown in Table 1.

Determination of excess heat power

As in the early stage of electrolysis, the formation of PdD_x alloy also produces heat. The diffusivity of H in the α phase of Pd is high³ at $4 \times 10^{-11} \text{ m}^2\text{s}^{-1}$. In the β phase, the diffusivity of H is somewhat lower, but is still high; the diffusivity of D in Pd is even higher than the diffusivity of H. Under our electrolysis condition, the one millimeter in diameter Pd sample was saturated by either H or D within a few hours. Since our cells were electrolyzed for at least two days before heat measurement, the heat power input (H_{in} (W)) to the cell was simply determined from the cell voltage (V_{cell}) and the current (I) applied to the cell, using the relationship shown as $H_{in} = (V_{cell} - V_{tn}) \times I$, where V_{tn} is the thermal neutral potential of water

$$V_{tn} = 1.53 \text{ V for D}_2\text{O} \quad (1)$$

$$V_{tn} = 1.48 \text{ V for H}_2\text{O}. \quad (2)$$

The heat power output (H_{out} (mW)) from the cell is simply the multiplication of calibration constant (C (W/volt)) and the voltage reading of TED (V_{TED} (volt)). The excess heat power is

Table 1. Sample Calibration Run

Voltage reading of TED in mV (corrected to baseline). Input power = 66.3 mW.

9.899

9.912

9.907

9.930

9.897

9.924

9.894

9.900

Average 9.908 + 2.2%

H_{out} minus H_{in} . The percent of excess heat power is the percentage of excess heat power relative to H_{in} .

The current was applied using an ECO battery cyler. The V_{TED} and the temperature of the Al block (T_{Al} °C) were monitored using the Hart Scientific Model 1701 measuring system coupled with Keithley Model 197 Microvolt DVM. This data was recorded with an IBM compatible PC every 20 or 30 minutes.

Determination of D/Pd

The amount of incorporated deuterium in the Pd was determined by using a Perkin-Elmer TGS-2 thermogravimetric analyzer (TGA). This experiment was performed on selected samples after the calorimetric experiment was completed. The weight loss was assumed to be entirely due to deuterium.

RESULTS AND DISCUSSION

Electrolyses were started outside of the calorimeter and continued for two to twelve weeks. Occasionally, cells were transferred to the calorimeter in order to monitor heat production. For glass cells, the duration of monitoring varied from one to three days. For stainless steel cells, the duration of monitoring varied from two to fourteen days, due to smaller total current applied. During these periods, the level of electrolyte was maintained so that the cathode was never exposed to the atmosphere. This eliminated the need to add water while the cell was in the calorimeter, thus the temperature of the cell remained undisturbed.

Glass cells were employed in the earlier runs. Weight loss measurements indicated that the loss of deuterium oxide was mainly due to electrolysis, to within one percent of accuracy. Therefore, we believe there is no significant recombination of oxygen and deuterium in the electrolysis cell. Figure 3 shows a typical one-plot of percent excess heat power as a function of time for a Pd cathode in a 0.1 M solution of LiOD in D_2O at current densities of 60 and 240 mA/cm². The corresponding heat powers were approximately 80 and 650 mW. The excess heat power observed was within two percent of the input heat. The annealed Pd showed similar results as the nontreated Pd.

The excess heat power from the control cells, Pt/0.1 M LiOD in D_2O and Pd/0.1 M LiOH in H_2O , is shown in Figs. 4a and b. The time axis shown is the actual time from the beginning of electrolysis. The excess heat power is, again, within two percent of

Pd in 0.1M LiOD/D₂O

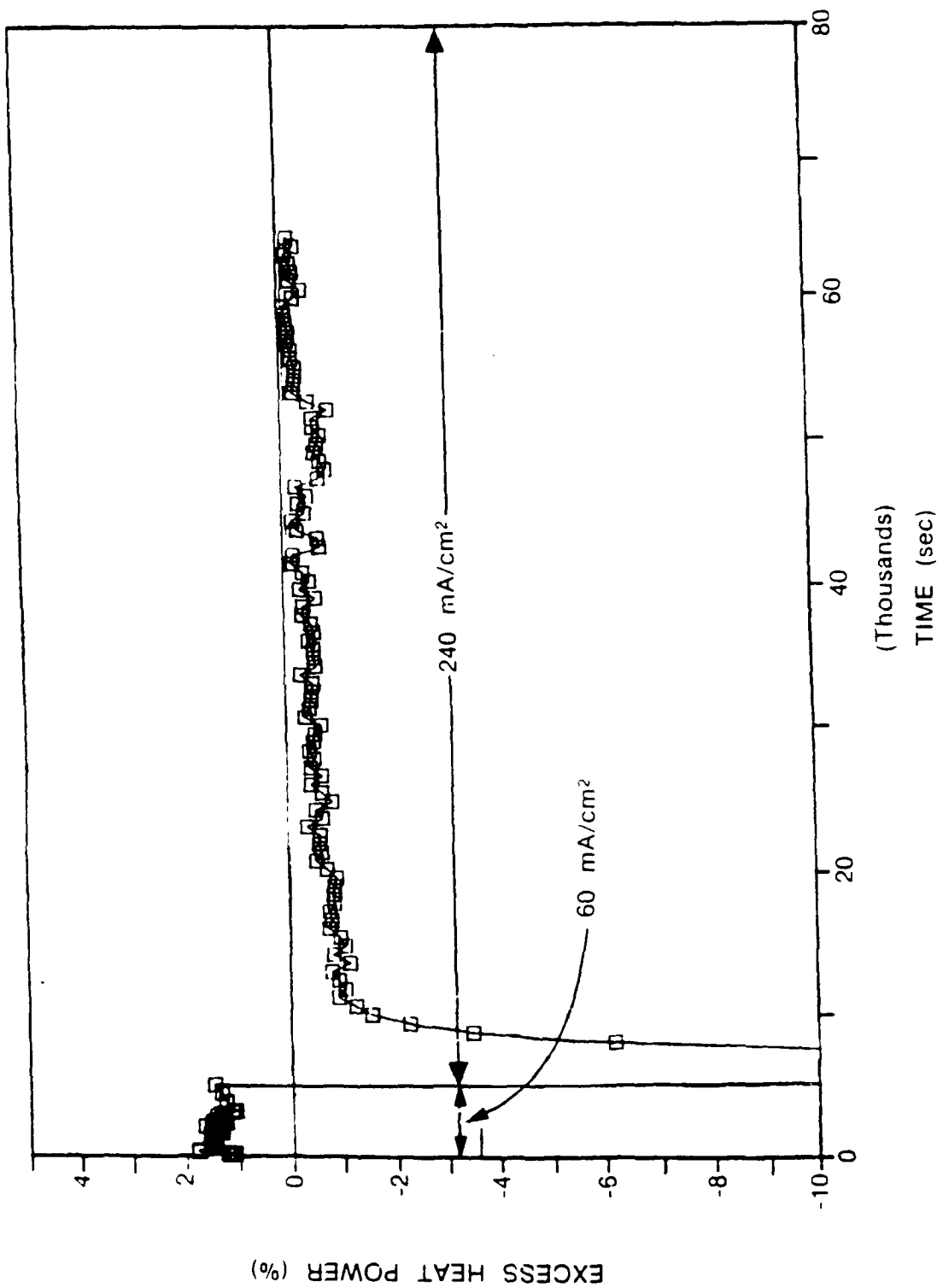

Figure 3. Percent of excess heat power (%) as a function of time in a day for Pd in 0.1 M LiOD/D₂O at current densities of 60 and 240 mA/cm² in glass cell.

Pd in 0.1M LiOH/H₂O

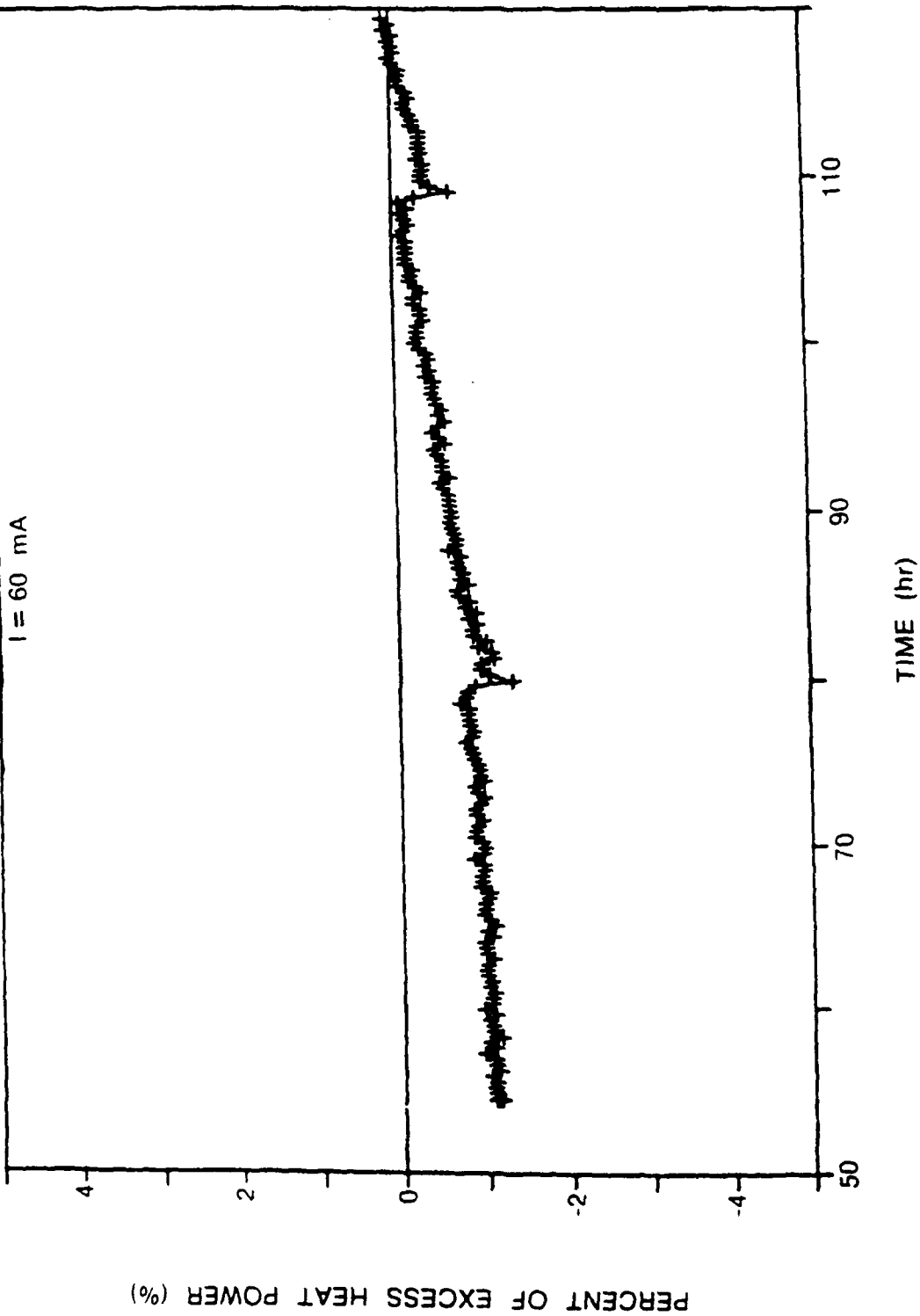

Figure 4a. Percent of excess heat power (%) as a function of time in glass cell.

Pt in 0.1M LiOD/D₂O

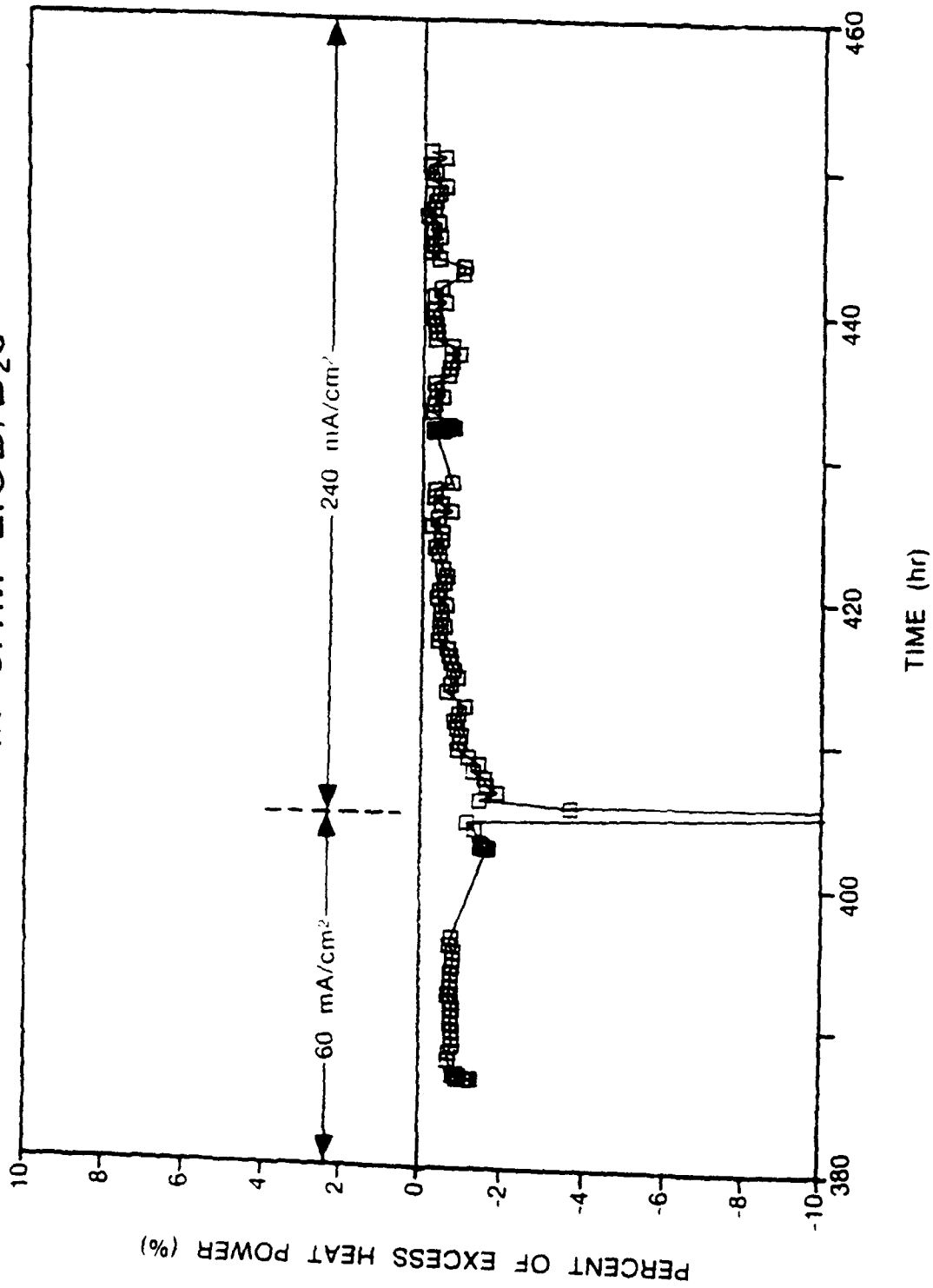

Figure 4b. Percent of excess heat power (%) as a function of time in glass cell.

the input heat. These results do not support Fleischmann and Pons's claims¹ of about 20 percent excess heat from Pd of 1 mm in diameter and 10 cm in length.

The typical percent excess heat power from cells using a stainless steel container is shown in Figs. 5a, b, and c. The heat power levels were about 9 and 310 mW at current densities of 60 and 600 mA/cm², respectively. The observed excess heat power at 60 mA/cm² was sometimes slightly higher than the two percent accuracy of the calorimeter. In all cases, however, the excess heat at 600 mA/cm² was within the accuracy of the calorimeter.

Under conditions similar to ours, Appleby et al.² found that there was no excess heat for Pd in 0.1 M LiOD/D₂O at a current density of 60 mA/cm², but there was 10 to 15 percent excess heat at 600 mA/cm². We cannot explain the discrepancies between our results and theirs. It is also interesting to note that Fleischmann and Pons¹ found excess heat of 23, 19, and 5 percent from Pd of a diameter of one millimeter at current densities of 8, 64, and 512 mA/cm², respectively. Their results of excess heat at current densities of 8 and 64 mA/cm² do not agree with those of Appleby et al.,² if we do not consider the differences in the containers that were used.

The excess heat power observed from experimental cells of Pd in 0.1 M LiOD/D₂O and from control cells, both Pd in 0.1 M LiOH/H₂O and Pt in 0.1 M LiOD/D₂O, are all less than two to three percent. Since these values are similar and below the estimated accuracy level of the calorimeter, we must conclude that the present experiments provide no evidence for the production of anomalous heat under the Fleischmann-Pons experimental conditions. Recently, Fleming et al.⁴ reported results similar to ours, i.e., with both the open and closed cells, when using a twin-cell isothermal calorimeter.

The amount of deuterium in Pd was measured after the calorimetric experiment was completed. Typically, the value was $0.65 \leq X \leq 0.70$ in PdD_x.

SUMMARY

It may be noted that the present results do not eliminate the possibility of anomalous heat production below the two percent level of confidence of our experiments. Table 2 summarizes the results of both the glass and stainless steel cells when using the twin-cell heat-conduction calorimeter. Under our

Pd in 0.1M LiOD/D₂O

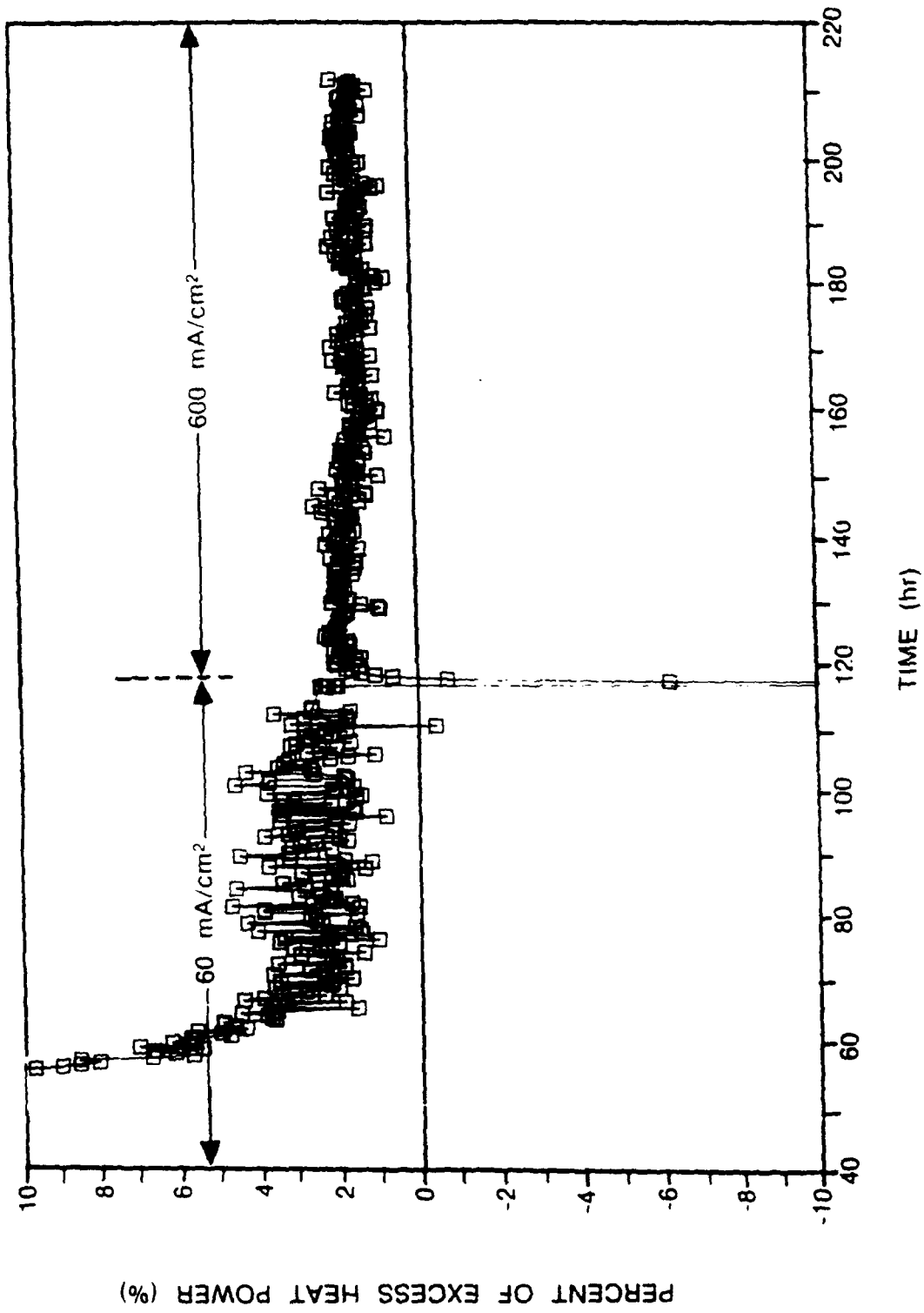

Figure 5a. Percent of excess heat power (%) as a function of time in stainless steel cell.

Pd in 0.1M LiOH/H₂O

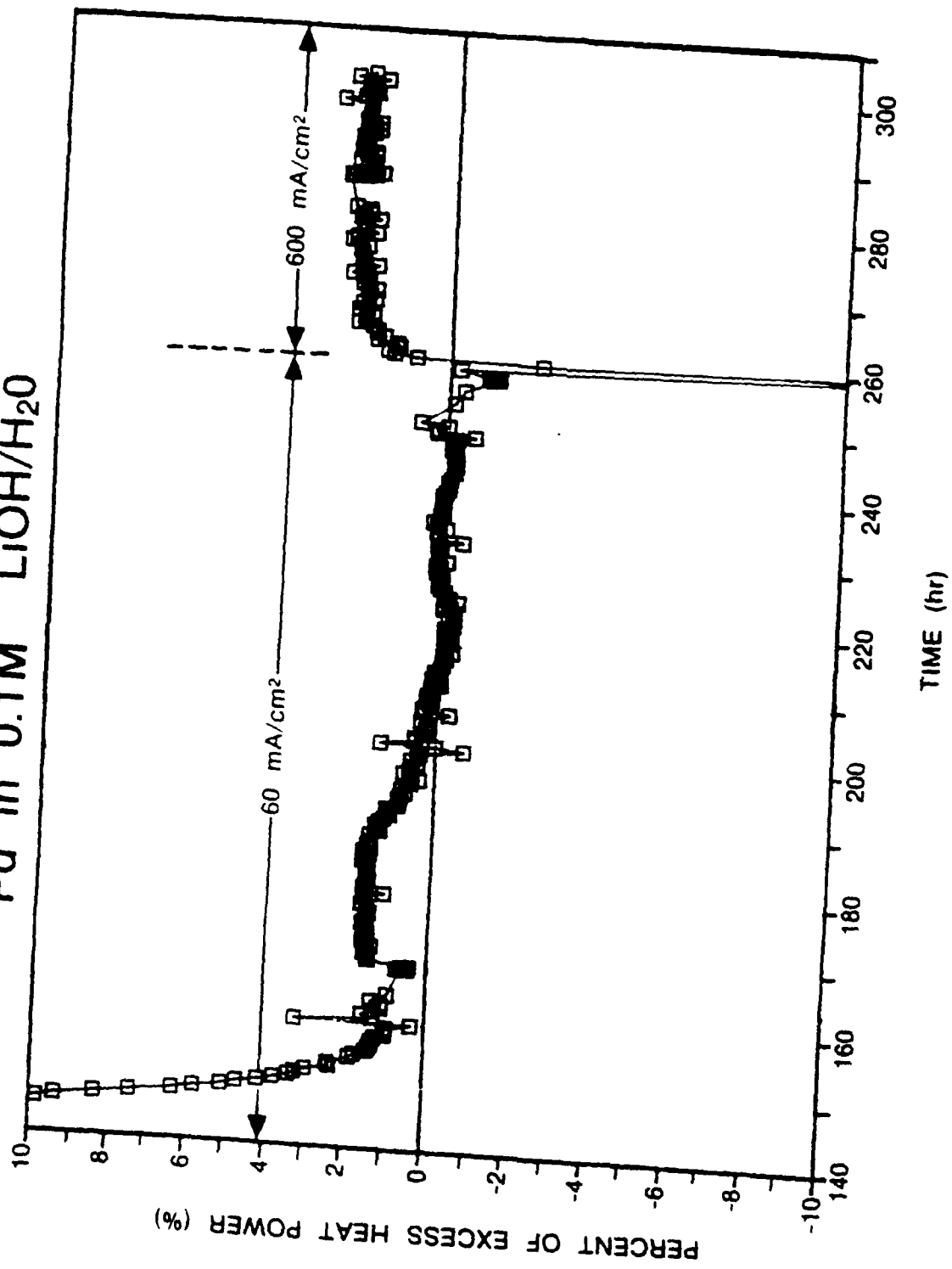

Figure 5b. Percent of excess heat power (%) as a function of time in stainless steel cell.

Pt in 0.1M LiOD/D₂O

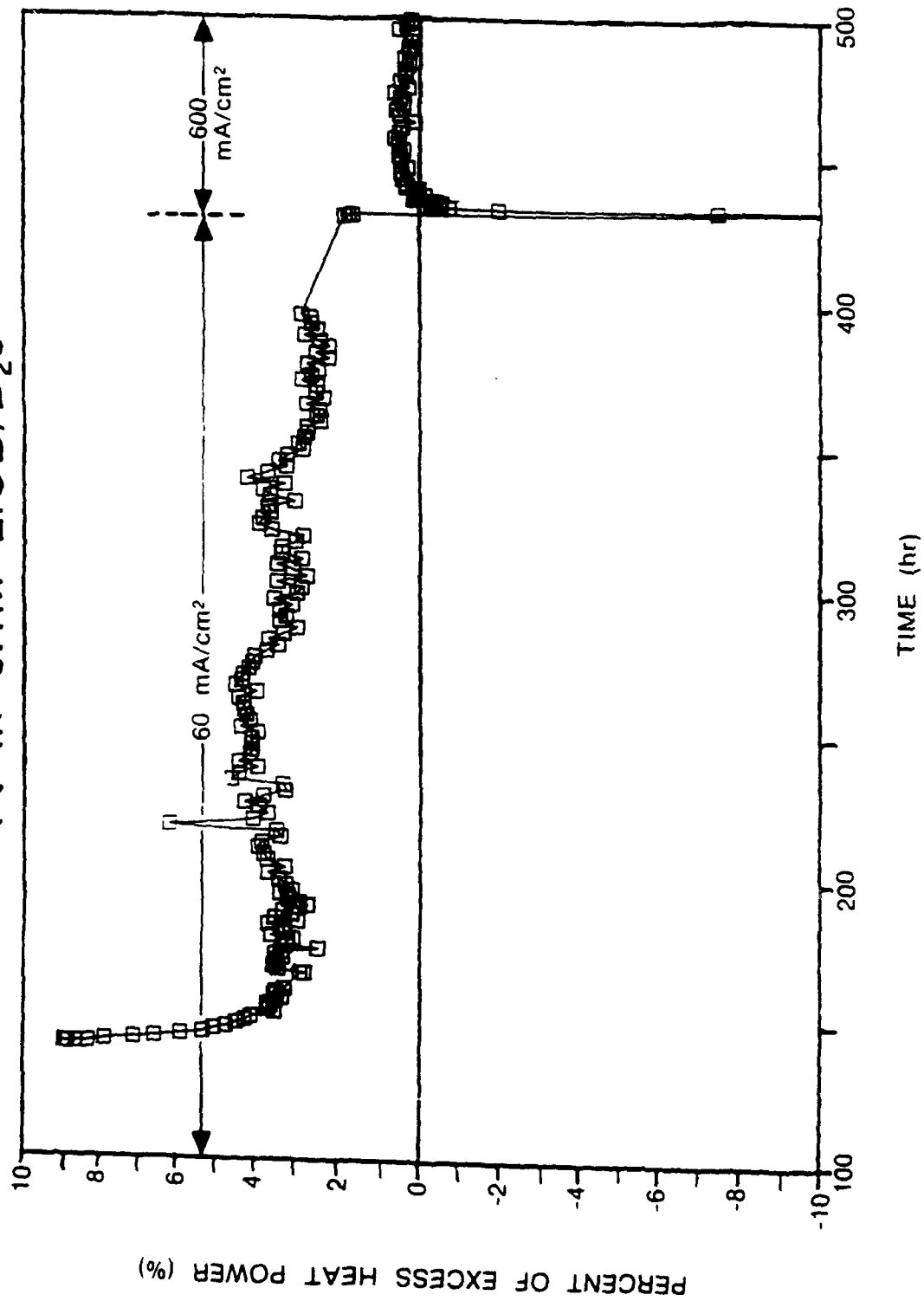

Figure 5c. Percent of excess heat power (%) as a function of time in stainless steel cell.

TABLE 2. Average percent excess heat power of experimental and control cells.

| CELL TYPE | CATHODE ELECTRODE TYPE | ELECTROLYTE | CURRENT DENSITY (mA/cm ²) | AVERAGE PERCENT EXCESS HEAT POWER (%) |
|---------------------|--|-----------------------------|---------------------------------------|---------------------------------------|
| GLASS | Pd, as received 1.0 mm dia, 25 mm long | 0.1 M LiOD/D ₂ O | 60 | 1.0 |
| | | | 240 | -0.5 |
| Glass | Pd, vacuum annealed 1.0 mm dia, | 0.1 M LiOD/D ₂ | 60 | 1 |
| | | | 240 | -0.5 |
| Glass (control) | Pd, as received 1.0 mm dia, 25 mm long | 0.1 M LiOH/H ₂ O | 60 | -0.5 |
| | | | | |
| Glass (control) | Pt, as received 1.0 mm dia, 25 mm long | 0.1 M LiOD/D ₂ O | 60 | -0.7 |
| | | | 240 | -0.5 |
| SS Can | Pd, as received 0.5 mm dia 10 mm long | 0.1 M LiOD/D ₂ O | 60 | 2 |
| | | | 600 | 2 |
| SS Can (control) | Pd, as received 0.5 mm dia 10 mm long | 0.1 M LiOH/H ₂ O | 60 | 1 |
| | | | 600 | 2 |
| SS Can (control) | Pt, as received 0.5 mm dia, 10 mm long | 0.1 M LiOD/D ₂ O | 60 | 3 |
| | | | 600 | 0.5 |

experimental conditions, we conclude that no anomalous heat could be detected which was of the magnitude reported by either Fleischmann and Pons or Appleby et al.

ACKNOWLEDGMENTS

The authors thank S. Srinivasan, Texas A&M University, for providing the 0.5 mm in diameter Pd wire for use in our stainless steel cells, and Dr. E. Potenziani II, Electronics Technology and Devices Laboratory, for vacuum annealing the Pd samples.

REFERENCES

1. M. Fleischmann and S. Pons, *J. Electroanal. Chem.*, 261, 301 (1989).
2. A. J. Appleby, Y. J. Kim, C. R. Martin, O. J. Murpny, and S. Srinivasan, to be published in *J. Electrochem. Soc.*
3. J. Volkl and G. Alefeld, in Hydrogen in Metals, edited by G. Alefeld and J. Volkl, (Springer-Verlag, Berlin, 1978), p. 321.
4. J. W. Fleming, H. H. Law, J. Sapjeta, P. K. Gallagher, W. F. Marohn, to be published in *J. Fusion Energy*.

ELECTRONICS TECHNOLOGY AND DEVICES LABORATORY
MANDATORY DISTRIBUTION LIST
CONTRACT OR IN-HOUSE TECHNICAL REPORTS

1 Nov 90
Page 1 of 2

Defense Technical Information Center*

ATTN: DTIC-FDAC

Cameron Station (Bldg 5)
Alexandria, VA 22304-6145

(*Note: Two copies for DTIC will
be sent from STINFO Office.)

Director

US Army Material Systems Analysis Actv

ATTN: DRXSY-MP

001 Aberdeen Proving Ground, MD 21005

Commander, AMC

ATTN: AMCDE-SC

5001 Eisenhower Ave.

001 Alexandria, VA 22333-0001

Commander, LABCOM

ATTN: AMSLC-CG, CD, CS (In turn)

2800 Powder Mill Road

001 Adelphi, Md 20783-1145

Commander, LABCOM

ATTN: AMSLC-CT

2800 Powder Mill Road

001 Adelphi, MD 20783-1145

Commander,

US Army Laboratory Command

Fort Monmouth, NJ 07703-5000

1 - SLCET-DD

2 - SLCET-DT (M. Howard)

1 - SLCET-DB

35 - Originating Office

Commander, CECOM

R&D Technical Library

Fort Monmouth, NJ 07703-5000

1 - ASQNC-ELC-IS-L-R (Tech Library)

3 - ASQNC-ELC-IS-L-R (STINFO)

Advisory Group on Electron Devices

201 Varick Street, 9th Floor

002 New York, NY 10014-4877

ELECTRONICS TECHNOLOGY AND DEVICES LABORATORY
SUPPLEMENTAL CONTRACT DISTRIBUTION LIST
(ELECTIVE)

1 Nov 90
Page 2 of 2

| | | | |
|-----|---|-----|--|
| 001 | Director Naval Research Laboratory ATTN: CODE 2627 Washington, DC 20375-5000 | 001 | Cdr, Atmospheric Sciences Lab LABCOM ATTN: SLCAS-SY-S White Sands Missile Range, NM 88002 |
| 001 | Cdr, PM JTFUSION ATTN: JTF 1500 Planning Research Drive McLean, VA 22102 | 001 | Cdr, Harry Diamond Laboratories ATTN: SLCHO-CO, TD (In turn) 2800 Powder Mill Road Adelphi, MD 20783-1145 |
| 001 | Rome Air Development Center ATTN: Documents Library (TILD) Griffiss AFB, NY 13441 | | |
| 001 | Deputy for Science & Technology Office, Asst Sec Army (R&D) Washington, DC 20310 | | |
| 001 | HQDA (DAMA-ARZ-D/Dr. F.D. Verderame) Washington, DC 20310 | | |
| 001 | Dir, Electronic Warfare/Reconnaissance Surveillance and Target Acquisition Ctr ATTN: AMSEL-EW-D Fort Monmouth, NJ 07703-5000 | | |
| 001 | Dir, Reconnaissance Surveillance and Target Acquisition Systems Directorate ATTN: AMSEL-EW-DR Fort Monmouth, NJ 07703-5000 | | |
| 001 | Cdr, Marine Corps Liaison Office ATTN: AMSEL-LN-MC Fort Monmouth, NJ 07703-5000 | | |
| 001 | Dir, US Army Signals Warfare Ctr ATTN: AMSEL-SW-OS Vint Hill Farms Station Warrenton, VA 22186-5100 | | |
| 001 | Dir, Night Vision & Electro-Optics Ctr CECOM ATTN: AMSEL-NV-D Fort Belvoir, VA 22060-5677 | | |