

AD-A237 021



**OFFICE OF NAVAL RESEARCH
END-OF-YEAR REPORT**

PUBLICATIONS/PATENTS/PRESENTATIONS/HONORS/STUDENT REPORT

for

Contract N00014-88-K-0482, Mod/Amend: P00001

R&T Code 413d017

Applications of Scanning Tunneling Microscopy to Electrochemistry

Nathan S. Lewis

California Institute of Technology

Department of Chemistry

Pasadena, California 91125

May 31, 1991

COPIES
INSPECTED
B
A-1

Reproduction in whole, or in part, is permitted for any purpose of the United States Government.

*This document has been approved for public release and sale; its distribution is unlimited.

91-02548



91 6 18 144

CERTIFICATION OF TECHNICAL DATA CONFORMITY

The Contractor, Nathan S. Lewis hereby certifies that, to the best of his knowledge and belief, the technical data delivered herewith under Contract No. N00014-88-K-0482, Mod/Amend P00001/R&T Code 413d017 is complete, accurate, and complies with all requirements of the contract.

Date May 31, 1991

Name and Title of Certifying Official Nathan S. Lewis, Associate Professor of Chemistry.

OFFICE OF NAVAL RESEARCH
PUBLICATIONS/PATENTS/PRESENTATIONS/HONORS REPORT

R&T Number: 413h008

Contract/Grant Number: N00014-88-k-0482

Contract/Grant Title: Applications of Scanning Tunneling Microscopy to Electrochemistry

Principal Investigator: Nathan S. Lewis

Mailing Address: Department of Chemistry, California Institute of Technology,
Pasadena, California 91125

Phone Number: (818) 356-6335

Fax Number: (818) 585-0147

E-mail Address: None

- a. Number of papers submitted to refereed journals, but not published: 1
- b. Number of papers published in refereed journals (list attached)*: 3
- c. Number of books or chapters submitted, but not yet published: 0
- d. Number of books or chapters published (list attached)*: 0
- e. Number of printed technical reports & non-refereed papers (list attached)*: 3
- f. Number of patents filed: 0
- g. Number of patents granted (list attached)*: 0
- h. Number of invited presentations at workshops or professional society meetings: 4
- i. Number of presentations at workshops or professional society meetings: 0
- j. Honors/Awards/Prizes for contract/grant employees (list attached)*: 3
(This might include Scientific Society Awards/Offices,
Promotions, Faculty Awards/Offices)
- k. Total number of Graduate Students and Post-Doctoral associates supported by at least 25% during this period, under this R&T project number:
Graduate Students: 2
Post-Doctoral Associates: 1
including the number of,
Female Graduate Students: 1
Female Post-Doctoral Associates: _____
the number of
Minority* Graduate Students: _____
Minority* Post-Doctoral Associates: _____
and, the number of
Asian Graduate Students: _____
Asian Post-Doctoral Associates: _____
- l. Other funding (list agency, grant title, amount received this year, total amount, and period of performance)*

* Use the letter and an appropriate title as a heading for your list, e.g.:

b. Published Papers in Refereed Journals, or, d. Books and Chapters published

* Minorities include Blacks, Aleuts, AmIndians, Hispanics, etc. NB: Asians are not considered an under-represented or minority group in science and engineering.

Part I:

a. Papers submitted to refereed journals

Rik Blumenthal, Reginald M Penner, Michael J. Heben and Nathan S. Lewis, "Pulse Induced Nanolithography of Graphite in H₂O: A Road to Chemical linkages to the Surface?" submitted to *J. Vac Sci. Technol.*

b. Papers published in refereed journals:

Nathan S. Lewis, "Mechanistic Studies of Light-Induced Charge Separation at Semiconductor Liquid Interfaces" *J. Phys. Chem.*, **94**, 6002 (1990).

Reginald M Penner, Michael J. Heben, Teresa Longin and Nathan S. Lewis "Fabrication and Use of Nanometer-Sized Electrodes in Electrochemistry" *Science*, **250**, 1118 (1990).

Reginald M Penner, Michael J. Heben and Nathan S. Lewis, "Mechanistic Investigations of Nanometer-Scale Lithography at Liquid-Covered Graphite Surfaces" *Appl. Phys Lett.*, **58(13)**, 1389 (1991).

c. No books or chapters were submitted.

d. No books or chapters were published.

e. Technical reports:

Technical Report #10, "Mechanistic Studies of Light-Induced Charge Separation at Semiconductor Liquid Interfaces"

Technical Report #11, "Mechanistic Investigations of Nanometer-Scale Lithography at Liquid-Covered Graphite Surfaces"

Technical Report #12, "Pulse Induced Nanolithography of Graphite in H₂O: A Road to Chemical linkages to the Surface?"

f. No patents were filed.

g. No patents were granted.

h. Invited presentations:

Scanned Probe Microscopy : STM and Beyond, January 1-6, 1991. N.S. Lewis : "The Electrode-Solution Interface"

Pittsburgh Conference on Analytic Chemistry and Applied Spectroscopy, March 3-8, 1991. N.S. Lewis : "Lithography and Chemical Reactions on Surfaces using Scanning Tunneling Microscopy"

American Chemical Society National Meeting, April 14-19, 1991. N.S. Lewis : "Electrochemistry at Nanometer-Sized Electrodes"

Electrochemical Society Meeting, May 5-8, 1991. N.S. Lewis : " Fabrication of Nanometer Sized Electrodes and their Use in Electrochemistry"

i. No contributed papers were presented.

j. Honors/Awards/Prizes:

Nathan S. Lewis: 1990 Fresenius Award of Phi Lamda Upsilon
 1991 ACS Award in Pure Chemistry
 Promotion to Full Professor of Chemistry

k. Graduate Students and Post-Doctoral Associates:

Graduate Students : Teresa Longin and Russell Pylkki
Post-Doctoral Associates : Reginald Penner and Rik Blumenthal

Female Graduate Student : Teresa Longin
No Female Post-Doctoral Associates were supported.

No Minority Graduate Students or Post-Doctoral Associates were supported.

No Asian Graduate Students or Post-Doctoral Associates were supported.

l. Other funding:

NSF : Chemical Control of Recombination at Semiconductor Surfaces: 4/1/91 to
3/31/92 : \$47,139.

DOE : Picosecond Dynamic Studies of Electron Transfer Rates at III-V
Semiconductor - Liquid Interfaces: 9/1/90 to 7/31/91 : \$93,949

Petroleum Research Fund : Cyclic Voltametry of Semiconductor Interfaces: 9/1/90
to 8/31/91 : \$20,000

Part II:

- a. Principal Investigator : Nathan S. Lewis
- b. Telephone Number : 818-356-6335
- c. Cognizant ONR Scientific Officer : Robert J. Nowak
- d. Project Description

The focus of research in the last year has been STM (Scanning Tunneling Microscopy) studies of electrode solution interfaces. STM, and its derivatives (e.g. AFM, Atomic Force Microscopy) are the only surface analytic methods capable of yielding real-space, atomic resolution, electronic and structural maps of immersed electrode surfaces. To achieve this goal, in the previous contract period we have developed STM tip preparation methodologies that enable atomic resolution imaging of electrode surfaces in solutions containing high (0.1 M) concentrations of electron donor and acceptor species. These techniques have significantly extended the applicability of STM to electrochemical investigations. Recent STM investigations of electrochemical systems have focussed on elucidating the mechanism of pulse bias lithography on a graphite surface under varied media.

- e. Significant Results during 1990/1991

In the past year, we have investigated the phenomena of pulse bias lithography on graphite in detail and in a variety of environments. Experiments performed in moist environments have been observed to behave qualitatively the same as moist air. Pit formation is observed to occur at a threshold pulse amplitude of 3 - 8 V, and varies significantly from each tip. Our recent results, in pure H₂O, have confirmed our preliminary results, reported earlier, that a sharp threshold pulse amplitude [$\pm (4.0 \pm 0.2$ V)] exists for pit formation on graphite surfaces in H₂O. In our effort to precisely identify this threshold amplitude, we discovered an entirely new type of surface modification. This feature appears as a protrusion from the surface, and is only formed at pulse amplitudes slightly below the threshold for pit formation. Subsequent investigation of these new domed features revealed that, although these features are stable to tunneling biases up to 500 mV, the application of a second bias pulse of only 0.2 V results in their conversion into pits which are almost identical to the pits formed by threshold bias pulses. We find this result to be extremely exciting and are currently pursuing the use of domes as chemical intermediates for the functionalization of the graphite surface.

- f. Future Research Directions

With continued support from the ONR, we plan to pursue a number of new directions which have been made possible by our past successes. Among the experiments proposed are efforts to:

- Continue our efforts to image dynamic surface transformations.
- Image semiconductor surfaces immersed in concentrated electrolyte.
- Pursue the use of pulse bias generated pits as nucleation sites for metal deposition.
- Pursue the use of pulse bias generated domes as intermediates for the functionalization of a graphite surface.
- Continue our studies of the rate of heterogeneous electron rate constants with nanodes.
- Measure rapid chemical reaction rates through the marriage of an STM and a nanode.
- Fabricate an array of nanodes to unambiguously whether heterogeneous electron transfer rate constants can exceed faster than 1 cm/s.

- g. Teresa Longin, a graduate student, is currently working on the project.
Russell Pylkki, a graduate student, is currently working on the project.
Rik Blumenthal, a post-doctoral associate, is currently working on the project.

Part III.

Enclosed are three viewgraphs: an introductory viewgraph, a viewgraph depicting pulse-bias nanolithography of graphite in water, and a concluding viewgraph. The explanatory text for the viewgraphs is as follows:

The introductory viewgraph lists the initial goals of the project and highlights our most significant accomplishments.

The second viewgraph depicts the modification of a graphite surface by a short (20 μ s) pulse (of arbitrary amplitude) applied to the typically constant bias present during tunneling. This process is also known as pulse-bias nanolithography. The top image represents the geometric relationship of a glass coated STM tip and a flat graphite surface during a typical tunneling experiment. Along each of the arrows originating from the top image is a plot of the bias pulse amplitude versus time that generates a modified surface, depicted in the image at the end of the arrow. The domed modification (middle, left) was discovered in our laboratory and can only be generated in an environment of pure water. These features have a lateral size comparable to a six member carbon ring and protrude from the surface by approximately one half of the thickness of a single layer of graphite. Through the application of a second bias pulse of only 0.2V, these features can be converted into single layer deep pits (middle, right). We believe that these domes represent a meta-stable chemical state on the surface, and we are currently exploring the concept of reacting these domes with molecules added to the solution (bottom, left). Metal deposition into pits is also currently being explored and is depicted in this figure (bottom, right).

The final viewgraph indicates the directions that we would like to pursue in future years.

Applications of STM to Electrochemistry

**N.S. Lewis
Caltech**

GOALS:

- In situ images of electrode/electrolyte interfaces
- Dynamic studies of surface rearrangements
- Surface modification
- Molecular/polymer imaging

ACCOMPLISHMENTS:

- Imaged graphite in contact with aqueous and other conducting electrolytes
- Made STM tips as small as 10\AA in radius to enable the above imaging
- Used these nanometer-scale electrodes for electrochemistry
- Investigated nanolithography on graphite surfaces and discovered unique meta-stable dome shaped surface modifications

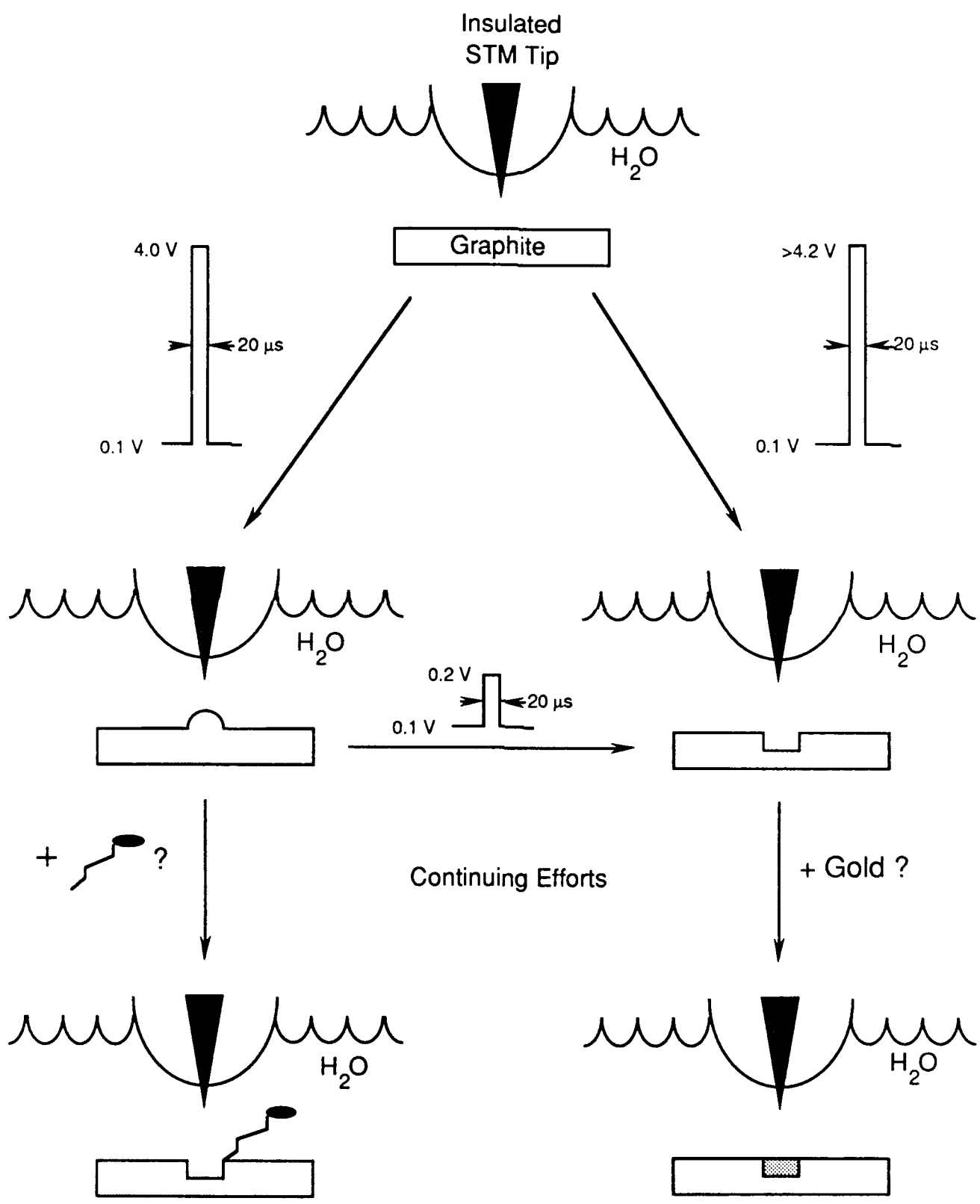

Future Directions

- Take advantage of dynamic STM capability to image surface rearrangements in real time
- Investigate bias pulse induced domes and pits on graphite for chemical modification and metal plating
- Investigate surface structures of various semiconductors
- Use nanometer-scale electrodes (nanodes) in novel electrochemical applications
- Use nanodes and microelectrode arrays to investigate limits on fast heterogeneous electron transfer rates