



2

# NCEL

April 1991

By Norman L. Helgeson, Ph.D.

Sponsored By Naval Facilities  
Engineering Command

## Technical Note

# USER DATA PACKAGE FOR COMPRESSED NATURAL GAS (CNG) VEHICLES FOR NAVY APPLICATIONS

DTIC  
ELECTE  
JUN 03 1991  
S B D

**ABSTRACT** Limits on environmental emissions from motor vehicles continue to be reduced by both federal and local regulatory bodies. 1990 legislation has established requirements for the use of alternatively-fueled fleet vehicles by 1994 in some parts of the country. Also, the availability of petroleum-based vehicular fuels is again being questioned. To address these concerns the Navy undertook experimental operation of a five-vehicle, compressed natural gas (CNG) vehicle fleet. Experience gained in operation of that fleet along with other data available has been used to prepare this User Data Package. This package provides background information and procedures whereby Naval activities can assess the desirability and economic feasibility for implementing a CNG-fueled vehicle fleet. It also provides procedures and recommendations for the design, procurement, and maintenance of both CNG fleet vehicles and CNG refueling stations.

DEFENSE TECHNICAL INFORMATION CENTER  
9100652

91 5 28 104

NAVAL CIVIL ENGINEERING LABORATORY PORT HUENEME CALIFORNIA 93043-5003

METRIC CONVERSION FACTORS

Approximate Conversions to Metric Measures				Approximate Conversions from Metric Measures			
Symbol	When You Know	Multiply by	To Find	Symbol	When You Know	Multiply by	To Find
		<b>LENGTH</b>				<b>LENGTH</b>	
in	inches	*2.5	centimeters	mm	millimeters	0.04	inches
ft	feet	30	centimeters	cm	centimeters	0.4	inches
yd	yards	0.9	meters	m	meters	3.3	feet
mi	miles	1.6	kilometers	km	kilometers	1.1	yards
		<b>AREA</b>				0.6	miles
in <sup>2</sup>	square inches	6.5	square centimeters	cm <sup>2</sup>	square centimeters	0.16	square inches
ft <sup>2</sup>	square feet	0.09	square meters	m <sup>2</sup>	square meters	1.2	square yards
yd <sup>2</sup>	square yards	0.8	square meters	m <sup>2</sup>	square kilometers	0.4	square miles
mi <sup>2</sup>	square miles	2.6	square kilometers	km <sup>2</sup>	hectares (10,000 m <sup>2</sup> )	2.5	acres
		0.4	hectares	ha			
		<b>MASS (weight)</b>					
oz	ounces	28	grams	g	grams	0.035	ounces
lb	pounds	0.45	kilograms	kg	kilograms	2.2	pounds
	short tons	0.9	tonnes	t	tonnes (1,000 kg)	1.1	short tons
	(2,000 lb)						
		<b>VOLUME</b>					
tsp	teaspoons	5	milliliters	ml	milliliters	0.03	fluid ounces
Tbsp	tablespoons	15	milliliters	ml	liters	2.1	pints
fl oz	fluid ounces	30	milliliters	ml	liters	1.06	quarts
c	cups	0.24	liters	l	liters	0.26	gallons
pt	pints	0.47	liters	l	cubic meters	35	cubic feet
qt	quarts	0.95	liters	l	cubic meters	1.3	cubic yards
gal	gallons	3.8	liters	l			
ft <sup>3</sup>	cubic feet	0.03	cubic meters	m <sup>3</sup>			
yd <sup>3</sup>	cubic yards	0.76	cubic meters	m <sup>3</sup>			
		<b>TEMPERATURE (exact)</b>					
°F	Fahrenheit temperature	5/9 (after subtracting 32)	Celsius temperature	°C	Celsius temperature	9/5 (then add 32)	Fahrenheit temperature

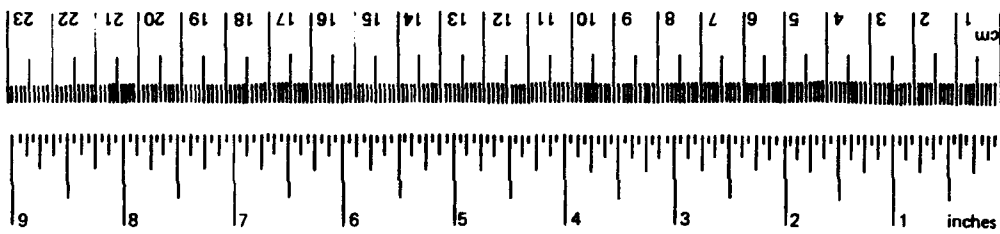

\*1 in = 2.54 (exactly). For other exact conversions and more detailed tables, see NBS Misc. Publ. 286, Units of Weights and Measures, Price \$2.25, SD Catalog No. C13.10-286.

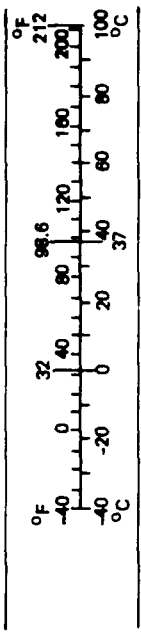

**REPORT DOCUMENTATION PAGE**Form Approved  
OMB No. 0704-018

Public reporting burden for this collection of information is estimated to average 1 hour per response, including the time for reviewing instructions, searching existing data sources, gathering and maintaining the data needed, and completing and reviewing the collection of information. Send comments regarding this burden estimate or any other aspect of this collection information, including suggestions for reducing this burden, to Washington Headquarters Services, Directorate for Information and Reports, 1215 Jefferson Davis Highway, Suite 1204, Arlington, VA 22202-4302, and to the Office of Management and Budget, Paperwork Reduction Project (0704-0188), Washington, DC 20503.

1. AGENCY USE ONLY (Leave blank)		2. REPORT DATE April 1991	3. REPORT TYPE AND DATES COVERED Final - Oct 1986 to Sep 1990	
4. TITLE AND SUBTITLE USER DATA PACKAGE FOR COMPRESSED NATURAL GAS (CNG) VEHICLES FOR NAVY APPLICATIONS			5. FUNDING NUMBERS DN - 668090 WU - R0829-804-532B	
6. AUTHOR(S) Norman L. Helgeson, Ph.D.				
7. PERFORMING ORGANIZATION NAME(S) AND ADDRESS(ES) Naval Civil Engineering Laboratory Port Hueneme, CA 93043-5003			8. PERFORMING ORGANIZATION REPORT NUMBER TN - 1829	
9. SPONSORING/MONITORING AGENCY NAME(S) AND ADDRESS(ES) Navy Facilities Engineering Command Alexandria, VA 22332			10. SPONSORING/MONITORING AGENCY REPORT NUMBER	
11. SUPPLEMENTARY NOTES				
12a. DISTRIBUTION/AVAILABILITY STATEMENT Approved for public release; distribution is unlimited.			12b. DISTRIBUTION CODE	
13. ABSTRACT (Maximum 200 words) <p>Limits on environmental emissions from motor vehicles continue to be reduced by both federal and local regulatory bodies. 1990 legislation has established requirements for the use of alternatively-fueled fleet vehicles by 1994 in some parts of the country. Also, the availability of petroleum-based vehicular fuels is again being questioned. To address these concerns the Navy undertook experimental operation of a five-vehicle, compressed natural gas (CNG) vehicle fleet. Experience gained in operation of that fleet along with other data available has been used to prepare this User Data Package. This package provides background information and procedures whereby Naval activities can assess the desirability and economic feasibility for implementing a CNG-fueled vehicle fleet. It also provides procedures and recommendations for the design, procurement, and maintenance of both CNG fleet vehicles and CNG refueling stations.</p>				
14. SUBJECT TERMS Alternative fuels, compressed natural gas, natural gas, alternatively-fueled-vehicles, CNG-fueled vehicles.			15. NUMBER OF PAGES 133	
			16. PRICE CODE	
17. SECURITY CLASSIFICATION OF REPORT Unclassified	18. SECURITY CLASSIFICATION OF THIS PAGE Unclassified	19. SECURITY CLASSIFICATION OF ABSTRACT Unclassified	20. LIMITATION OF ABSTRACT UL	

## CONTENTS

	Page
<b>SECTION I. INTRODUCTION</b> .....	1
CNG EQUIPMENT .....	1
GENERAL CONSIDERATIONS .....	2
CNG-FUELED VEHICLE TESTS .....	4
<b>SECTION II. PLANNING</b> .....	7
DESIRABILITY/NEED .....	7
FEASIBILITY STUDY .....	8
Economic Analysis .....	8
Physical Resources .....	10
Funding .....	10
Organizational Requirements .....	10
PROJECT IMPLEMENTATION .....	11
LIFE CYCLE CONSIDERATIONS .....	11
FUTURE AIR POLLUTION REGULATIONS .....	12
<b>SECTION III. DESIGN</b> .....	13
CNG VEHICLE CONVERSION KIT .....	13
Conversion Kit Description .....	13
Vehicle Performance .....	14
Single or Dual Fuel .....	14
CNG Fuel Storage .....	15
Fuel Pump .....	15
Fuel Use .....	16
Quality Assurance .....	16
CNG REFUELING STATION .....	16
Refueling Station Operator .....	16
Refueling System .....	17
Service Station Metering .....	18
IMPACT ON EXISTING DOCUMENTS .....	19
<b>SECTION IV. PROCUREMENT</b> .....	21
CONTRACTING APPROACH .....	21
Recommendation .....	21
Procurement Responsibility .....	21

	Page
GENERAL GUIDANCE .....	21
Contract Items .....	21
Considerations .....	22
<b>SECTION V. OPERATION AND MAINTENANCE SUPPORT .....</b>	<b>25</b>
SUPPORT CONCEPT .....	25
OPERATION AND ORGANIZATIONAL LEVEL MAINTENANCE .....	25
Vehicles .....	25
Refueling Station .....	25
INTERMEDIATE LEVEL MAINTENANCE .....	26
Vehicles .....	26
Refueling Station .....	26
DEPOT LEVEL MAINTENANCE .....	26
Vehicles .....	26
Refueling Station .....	26
PERSONNEL AND TRAINING .....	26
Personnel .....	26
Operator Training .....	27
Vehicle Mechanic Training .....	27
Other Personnel Training .....	27
DOCUMENTATION .....	27
REPAIR PARTS AND CONSUMABLES .....	28
SUPPORT AND TEST EQUIPMENT (S&TE) .....	29
FACILITIES .....	29
PACKAGING, HANDLING, STORAGE, AND TRANSPORTATION (PHS&T) .....	29
<b>SECTION VI. ACKNOWLEDGMENTS .....</b>	<b>31</b>
<b>SECTION VII. REFERENCES .....</b>	<b>33</b>
<b>APPENDIXES</b>	
A - Summary of Test Results and Lessons Learned for CNG-Fueled Vehicles at PWC, San Diego .....	A-1
B - Sample Purchase Description Specifications for CNG Vehicle Conversion Kits and Refueling Station .....	B-1
C - Suppliers of CNG Vehicle Supplies and Services .....	C-1
D - A.G.A. Requirements for Natural Gas Vehicle (CNG) Conversion Kits .....	D-1



<b>Accession For</b>	
NTIS GRA&I	<input checked="" type="checkbox"/>
DTIC TAB	<input type="checkbox"/>
Unannounced	<input type="checkbox"/>
Justification	
By _____	
Distribution/	
<b>Availability Codes</b>	
<b>Dist</b>	<b>Avail and/or Special</b>
A-1	

## SECTION I INTRODUCTION

The legal limits for vehicular emissions to the environment continue to be reduced by both federal and local agencies. Some fleets of vehicles, by law (Ref 1 through 4), will be required to convert to alternative fuel operation within the next 2-4 years. As this requirement is of great significance to the Navy, the Navy is preparing to operate some of its administrative vehicles on compressed natural gas (CNG) or other alternative fuel. Future petroleum shortages may also affect the availability of gasoline for the Navy's automotive vehicles. Having the capability for using CNG could help to relieve that concern. Moreover, as the cost of natural gas decreases, CNG becomes an economically attractive alternative to gasoline. Therefore, it is to the Navy's advantage to investigate and use CNG where cost effective.

This user's guide has been prepared to assist activities having an in-house capability for vehicle maintenance determine if CNG can be used to their advantage for fueling their vehicles. Procedural recommendations for implementing a CNG-fueled vehicle fleet are included. Results of a Navy trial test with a CNG-fueled, five-vehicle fleet at the San Diego Naval Station are summarized below, and are discussed in detail in Appendix A.

### CNG EQUIPMENT

Two types of equipment are involved in CNG-fueled vehicle operations: (1) CNG vehicle conversion kits, and (2) CNG-refueling stations. Vehicle conversion kits (Figure 1), typically, include CNG storage tanks (1 or more), a gas pressure reducer (3000 psi to ambient), a gas/air mixer, control valves, a gas gauge, high and low-pressure tubing, and electrical components. The installed cost ranges from \$2000.00 (for a low-mileage sedan) to as much as \$7000.00 (for a bus). The cost depends upon both the particular conversion kit selected and the CNG storage capacity required for the vehicle. A kit requires 2 to 3 days for installation. Because automotive manufacturers do not, yet, produce CNG-fueled vehicles or CNG conversion kits for sale to the public, CNG conversion kits must still be purchased and installed as after-market equipment.

CNG refueling stations are not generally available to the public. Therefore, a major part of the problem of operating CNG-fueled vehicles is ensuring that a reliable, cost-effective supply of CNG is available. To do this the fleet user must often undertake the construction and operation of a CNG refueling station, himself. Components of a refueling station (Figure 2) include compressors, storage cylinders, appropriate controls, facilities for both slow and fast-fill refueling, and appropriate

safety equipment. For a 50-vehicle fleet the installed cost of such a station is approximately \$125,000.00 (\$125.K). Assuming an average cost for an installed vehicle conversion kit of \$2.5K, the total capital cost for this 50-vehicle fleet would be \$250.K (\$125.K if the CNG refueling station is already available).

## GENERAL CONSIDERATIONS

The advantages and disadvantages for implementing a CNG-fueled vehicle fleet at a specific site vary. However, the factors that should be considered are:

1. Alternative Fuels Required. Alternative fuels will soon (within 2-3 years) be required for fleet vehicles in certain areas of the country to reduce automotive emissions to the atmosphere.
2. Petroleum Savings. At a time when oil imports are approaching 50 percent of total U.S. consumption and our countries oil supplies are periodically threatened, use of CNG will substitute a domestically produced fuel for its vehicles and will help the nation reduce its petroleum consumption.
3. Fuel Cost. The cost of CNG (for an equivalent gallon) may, in some locales, be appreciably less (30 - 60 cents) than gasoline. However, it must be determined on a case by case basis whether the anticipated savings from the reduced cost of CNG will offset the capital expenditures required to implement a CNG-fueled vehicle fleet.
4. Environmental Emissions. As CNG is considered to be a "clean fuel," the total quantity of pollutants emitted (reactive hydrocarbons, nitrogen oxides, carbon monoxide, and solid particulates) is reduced. Also, as natural gas is carbon poor (low carbon to hydrogen ratio) compared to gasoline, it produces about 1/3 less CO<sub>2</sub> (a greater quantity of H<sub>2</sub>O is produced).
5. Refueling Stations. Public CNG refueling stations are not generally available. Therefore the CNG vehicle owner must make special arrangements for refueling vehicles and may be required to construct a compression and refueling station. CNG refueling stations require more maintenance than equivalent gasoline stations, and high-pressure natural gas presents different (although not necessarily greater) safety problems than gasoline stations.
6. Conversion Kit Suppliers. Automotive manufacturers do not, yet, produce CNG-fueled vehicles nor CNG conversion kits for sale to the public, (General Motors is just now starting an experimental program for fleet users of CNG fuel). Some good after-market vendors for conversion kits are available, but they are not easily accessible in all areas. Availability of spare parts and service can be a problem. The increasing involvement of the American Gas Association, local gas utilities, and the entry of original equipment manufactures into the market may help provide improved CNG vehicle support.

7. **Optimized CNG Operation.** To optimize performance of CNG-fueled vehicles (for power, economy, and environmental emissions) the vehicles must be dedicated to CNG operation (i.e., operated only with CNG fuel). This is the long-range goal for CNG vehicles. Since CNG refueling stations are not widely available and the range of CNG fueled vehicles is often limited, most vehicles are now converted to dual-fuel (i.e., CNG plus gasoline) operation.

8. **Vehicle Performance.** Vehicle power losses following conversion to CNG operation can range from 5 to 15 percent. The power loss for dedicated (single-fuel) vehicles is less than for dual-fueled vehicles. For the latter, power loss can be mitigated (but not eliminated) by the use of dual-curve ignition systems.

9. **Vehicle Range (single-fuel/dual-fuel).** Vehicle range is increased when using both CNG and gasoline, but can be substantially reduced when using only CNG. Adding sufficient CNG storage capacity to provide a CNG vehicle range equivalent to that of gasoline will significantly reduce the load-carrying capacity of the vehicle. For each vehicle converted to CNG operation, some compromise must be reached between performance, load-carrying capability, and vehicle range.

10. **Operator Training.** Little operator training is required, however, some is essential. Operators tend to use that fuel which causes the fewest operational problems. For dual-fueled vehicles, keeping the CNG-fueled vehicles operating properly with an adequate supply of CNG increases the number of miles that the operator will choose to use CNG. The latter is necessary to achieve an economic payoff for the CNG installation.

11. **Reduced Maintenance.** Because CNG is a clean-burning fuel (low carbon buildup) some aspects of vehicle maintenance are reduced. For example, the time between required oil changes and tune-ups can be increased substantially. This saves the cost of the oil, the labor to change it, and also the cost of disposing of the old oil (which is becoming an increasingly difficult problem).

12. **Increased Maintenance.** Although the maintenance procedures for CNG-fueled vehicles are similar to those for gasoline-fueled vehicles, the time required to acquire maintenance proficiency (e.g., tuning the engine) can cause difficulties for an extended period of time after CNG start-up, unless maintenance training is carefully planned. Dual-fueled vehicles seem to require more frequent adjustments to keep engines operating at peak performance than do single-fueled vehicles.

13. **Safety.** Tests have demonstrated that CNG storage tanks used aboard vehicles withstand considerably greater collision impact than gasoline tanks. If a CNG tank does rupture, natural gas dissipates more quickly than does gasoline so that the chances of ignition are reduced. Therefore, vehicle safety is generally claimed to be improved for CNG fuel systems.



14. Fuel Security. Unlike gasoline or other liquid fuels, CNG cannot be easily stolen from a vehicle.

15. Sulfur Odor. A sulfur-type odor is often evident in the vicinity of the CNG-refueling station.

### CNG-FUELED VEHICLE TESTS

A test program was conducted at PWC, San Diego, to demonstrate the feasibility of using CNG as an alternative fuel for the Navy's administrative vehicles. A fleet of five vehicles (four vehicle types using three kinds of CNG kits) was converted to dual-fuel operation. The vehicles were operated a total of 105,462 miles over a period of 3 years for an average of 6,816 miles per vehicle per year. Fifty-four percent of the fuel used (7,260 equivalent gallons) was CNG. The remainder was gasoline. A number of practical problems were identified which, if not taken care of by careful planning and execution, would interfere with the successful implementation and operation of a CNG-fueled vehicle fleet. Major project results are as follows:

1. Natural gas costs at PWC, San Diego (including the PWC surcharge to base utility customers) were actually greater per equivalent gallon than was the cost of gasoline. Based on economics, alone, CNG was not a good alternative fuel choice. At other locations (or times), CNG fuel could be used to economic advantage. (Note: This test location was chosen to establish experimental control rather than to demonstrate the economic viability of CNG fuel.)

2. Assuming a fuel cost differential of \$0.50 per equivalent gallon of CNG (savings compared to gasoline), the fuel savings per vehicle would have ranged from \$44.50 per year for a 1/2-ton pick-up, to \$761.00 per year for a 3/4-ton pick-up. The calculated savings, in each case, was the product of the assumed savings per gallon (\$0.50) and the total fuel consumed by each vehicle per year.

3. The low but highly variable calculated fuel savings per vehicle demonstrates the importance of: (a) selecting for conversion to CNG operation those vehicles that would use a substantial quantity of fuel each year, and (b) ensuring that the vehicles converted were operated on natural gas (rather than gasoline) a high percentage of the time. This would permit a more rapid payback of the initial investment cost (e.g., \$2500.00 to \$5000.00 per vehicle for conversion to CNG operation) and also provide a greater environmental benefit.

4. The percentage of time the vehicles are operated on CNG can be increased by: (a) converting the vehicles to dedicated CNG (CNG only) operation, and/or (b) making it more desirable for the operators to use CNG. The latter can be accomplished by: (a) maintaining good vehicle performance, (b) ensuring an adequate CNG fuel capacity for each vehicle, and (c) providing adequate driver training and monitoring CNG miles driven (cf., mileage meters).

5. Although maintenance requirements for CNG-fueled vehicles are similar to those for gasoline-fueled vehicles, the differences can be troublesome. In the present program a substantial period of time (> 2 years) was required to resolve the operational "bugs" that arose during implementation of the CNG. Several factors contributed to this: (a) the simultaneous installation of three different types of CNG kits placed an excessive burden on the mechanics, (b) the vendor support and training of Navy mechanics was not adequate (possibly because only one or two CNG kits were purchased from each vendor), and (c) although necessary to provide adequate vehicle range, the use of dual-fuel as opposed to dedicated CNG operation complicated maintenance procedures and reduced vehicle performance. These results emphasize the need for adequate vendor involvement and accountability at the start-up of the CNG fleet and for some period thereafter. They also emphasize the need for adequate training of Navy mechanics in the subtleties of the CNG fuel systems.

6. Because of the variety of equipment involved in the test fleet (five vehicles of four different types with three kinds of CNG fuel systems), maintenance data could not be accumulated to statistically show the advantages often claimed for CNG operations (e.g., reduced frequency of oil changes and tune-ups).

7. The CNG refueling station assembled for this project was of adequate size and included a backup compressor. CNG was always available, however, the mechanics felt that required maintenance was excessive. Therefore, heavier-duty compressors are recommended for continued, long-term operation.

The results of this test program, along with those from other sources, were used in the preparation of this User Data Package.

## SECTION II

### PLANNING

As the CNG-fueled vehicle industry is in its infancy, the Navy does not, yet, have a policy or an existing supply and support system for acquiring and operating alternatively-fueled vehicles Navywide. Navy engineering field divisions can provide local activities with technical advice and assistance through the Transportation Equipment Maintenance Centers (TEMC) (Ref 5). However, the authority and responsibility for investigating and undertaking a CNG-fueled vehicle project remains with the individual commands. Therefore, local commands must carefully review the requirements and the basis for implementing a CNG-fueled vehicle fleet to ensure that it is sound and that sufficient local organizational support can be provided.

The CNG-fueled vehicle program will be operated and maintained by public works under the general guidance already established by the Navy for conventional vehicles (Ref 5). Those practices must be modified at the local level to ensure that adequate procedures for the acquisition, logistical support, maintenance, and operation of CNG-fueled vehicles are available. The phases for implementing a CNG-fueled vehicle project are:

- a. Assess Desirability/Need
- b. Conduct Feasibility Study
- c. Develop and Execute Implementation Plan.

### DESIRABILITY/NEED

Navy managers are interested in applying new technologies to improve the economics of their departments, meeting changing environmental regulations, and enhancing the public's perception of the Navy. Conversion of short-run fleet vehicles to operate on CNG fuel can save the Navy money, reduce petroleum consumption, and reduce vehicular emissions to the atmosphere. In the latter case a command may wish to undertake the implementation of a CNG-fueled vehicle fleet, even if not required, to gain experience for the possible future operation of alternatively-fueled vehicles. Where justified, the implementation of a CNG-fueled vehicle fleet can be viewed as not only serving the needs of the Navy but as a contribution to the public welfare.

## FEASIBILITY STUDY

This feasibility study has been divided into four areas: (1) economics, (2) physical resources, (3) funding, and (4) organizational requirements.

### Economic Analysis

The data required for an initial economic evaluation of a CNG-fueled vehicle fleet are: (a) the local cost of natural gas (NG), (b) the local cost of gasoline, (c) the composition of the vehicle fleet to be converted to CNG, and (d) data for the design and construction of a refueling station.

**Cost of Natural Gas.** The cost of natural gas (\$/therm) for CNG-fueled vehicles is quite variable. In most cases the user must purchase natural gas from the utility and construct and operate a compression and refueling station himself. However, in a few cases CNG can be purchased directly from utility-owned-and-operated, fast-fill CNG stations. Also, some utilities are starting programs where they will finance and construct CNG refueling stations at the user's site, if a guaranteed minimum quantity of CNG will be purchased annually by the fleet operator. Utilities are also establishing special CNG-vehicle fuel rates (with the approval of regulatory commissions) to encourage the use of CNG fuel (Ref 6). In all of these cases the user needs to negotiate guaranteed delivery rates, delivery schedules, CNG pressure, and the cost of the CNG with the suppliers.

When natural gas must be purchased at low pressure and compressed on-site, several additional charges must be added to the cost charged by the natural gas supplier (see Table 1). The base cost of the natural gas can be less than normal commercial or industrial rates (if a special CNG-vehicle rate applies). Navy public works centers may also add a charge to the cost of the gas and payment of a state road tax is sometimes required, although several states have passed laws exempting CNG for vehicle use from state tax (Ref 7).

For natural gas supplied at 5.0 psi, approximately 0.75 kW-Hr (\$.05 for nighttime rates) of electricity is required to compress a therm of gas to 3600 psi (stored at 3600 psi for delivery to vehicles at 3000 psi), and compressor station maintenance has been estimated at \$.08/kW-Hr (Ref 8). Summing these quantities provides an estimate of the cost per therm for CNG. As a vehicle uses approximately 1.1 therms of CNG for every gallon of gasoline that it would normally consume, the cost per therm must be multiplied by 1.1 to obtain the cost of CNG that is equivalent to one gallon of gasoline.

**Cost of Gasoline.** The cost of gasoline used at the activity (including appropriate taxes) is available from public works. The difference between the cost of CNG per equivalent gallon and that for gasoline is the projected dollar savings per gallon.

**Vehicle Selection.** The general criteria for the selection of vehicles to be converted to CNG or dual-fuel operation are provided in Table 2. However, to select the specific vehicles of interest first characterize the candidate vehicles according to fuel usage (gallons/mile and miles/day, see Table 3). Multiplying the projected gallons used/day by

dollar savings per gallon (see above) provides the daily fuel savings/vehicle. Based on the projected daily use of CNG and the anticipated filling frequency (i.e., daily, bi-daily, or weekly), the required CNG storage capacity for each vehicle type can be determined and the installed cost of the CNG conversion kit estimated (see Table 4). Dimensional data, storage capacities, and weights of fiber-reinforced composite steel cylinders for CNG vehicles are provided in Table 5.

Dividing the fuel savings per day (for each vehicle type) into the cost for installing the CNG conversion kit provides a simple payback (SPB, see Table 3) for each vehicle type. The three sample calculations presented show that those vehicles consuming larger amounts of fuel provide for a quicker payback. (Note that these calculations do not include amortization of the refueling station unless that cost has already been included in the cost of CNG purchased from a supplier). These SPB's are useful for identifying the vehicle types that offer good economic incentive for implementing a CNG-fueled vehicle fleet and for eliminating those types that are not promising. Figure 3 shows the SPB for the CNG conversion kit (in years) as a function of the gasoline consumed per operating day (or year), dollar savings per gallon, and cost of the CNG vehicle conversion.

Vehicle maintenance costs were not included in these estimates. This is because the difference in maintenance costs for gasoline and CNG-fueled vehicles has not been clearly demonstrated to be significant. Although some CNG fleet operations have reported good maintenance savings, others have reported increased costs. It is believed that maintenance costs may decrease and provide a net savings as the operating requirements of CNG-fueled vehicle fleets become more standardized and as maintenance personnel become more familiar with required procedures.

**Refueling Station.** A reasonable first estimate for a refueling station for a typical 50-vehicle fleet would include a compressor with a capacity of 50 CFM. Such a station, where 70 percent of the vehicles are filled by slow-fill, would cost about \$125.K (or \$2500.00 per vehicle see Tables 6 and 7). The major cost item of the refueling station is the compressor. Its cost depends, primarily, upon (a) the quantity of CNG required, and (b) the compression ratio (final gas pressure/initial gas pressure). For a typical CNG-fueled fleet (sedans and light-duty trucks) a rule of thumb is to provide a compressor that will supply about 1 CFM of CNG per vehicle (Ref 9). Operating 24 hours a day, a 50 CFM compressor provides the equivalent of 13.0 gallons of CNG per vehicle for a 50-vehicle fleet. However, to achieve a balance between availability and economy, suppliers recommend compressor duty cycles of 13 to 18 hours per day (Ref 10). Therefore, for a 13-hour per day duty cycle, the 50 CFM compressor provides about 7.0 gallons per vehicle per day. Extending the duty cycle to 18.0 hours per day would allow for a 38 percent expansion of the vehicle fleet at no additional capital cost.

If the vehicle fleet is not typical (e.g., several buses are included which may use 40-50 gallons per day), the rule of thumb of 1 CFM per vehicle would no longer be appropriate and the compressor size would have to be adjusted to accommodate the actual CNG required (keeping in mind a maximum compressor duty cycle of ~18 hours per day). Doubling the suction pressure to the compressor (e.g., increasing the natural gas supply pressure from 150 to 300 psi) can often double the capacity of a

given compressor for a small increase in cost. Further savings in operating costs can also be achieved (~20 percent reduction in compression costs) by halving the compression ratio. Therefore, there is good economic incentive to locate the refueling station as close as possible to a high-pressure natural gas supply line, if one is available locally.

### **Physical Resources**

The physical resources required for a CNG refueling station are: (a) sufficient land area for the slow-fill and fast-fill stalls and compressor station, (b) an adequate, accessible supply of natural gas, (c) electrical power (3-phase/220 or 440 volts) and water utilities, and (d) adequate access for personnel and vehicles to the site. The land area required will depend, largely, upon the number of slow-fill stalls required for the refueling station, although no net increase in overall parking space is required as the vehicles must be parked somewhere. A reasonable first estimate would be to accommodate 70 percent of the CNG-fueled vehicles with a slow-fill (overnight) stall. The compressor station will also require an area of approximately 15 by 20 feet, and driveway space for 2 to 4 vehicles for fast-fill will also be required. Locating the refueling station near a high-pressure natural gas supply (up to 500 psi may be available) line can provide substantial savings in the construction of short gas lines and low compressor capital and operating costs. Roadways and personnel access may require special construction for the site chosen.

### **Funding**

Acquisition of the capital required to fund installation of the CNG-vehicle conversion kits and to construct a CNG refueling station is the responsibility of the local activity. Capital requirements for construction of the refueling station can sometimes be avoided if CNG can be purchased directly from a utility or from a third-party supplier (see Section III). Although the cost of CNG retrofit kits for a sedan are in the range of \$ 2.0K to \$3.0K, the incremental cost for CNG-fueled vehicles (when and if produced by automobile manufacturers) could be considerably less. Further, the Alternative Motor Fuels Act of 1988 establishes incentives for manufacturers to produce alternatively-fueled vehicles and authorizes payment of the incremental cost of CNG equipment on some new vehicles purchased by the government. It must be noted, however, that no major automobile manufacturer is, yet, marketing a CNG-fueled vehicle (Ref 11). Therefore, the use of retrofit kits for CNG-fueled vehicles is the only option now available to users and current capital costs reflect the higher costs of these after-market retrofit kits.

### **Organizational Requirements**

A change in vehicle operations will mean a change in job responsibilities for some people. Therefore, as part of the feasibility study, those personnel who will have responsibilities for the operation of the CNG fleet should be consulted for their ideas and preferences. Maintenance personnel will be affected most. Handled correctly, learning CNG vehicle maintenance skills can add substantial interest to vehicle

mechanics jobs. Handled incorrectly, mechanics will resent having to learn the new skills and not having been consulted on how changes in the maintenance procedures were made. Care of the vehicles will suffer. Maintenance of the refueling station will, normally, be handled by personnel different from those that maintain the vehicles. In many cases the assistance of off-base personnel may be required for some refueling station maintenance requirements. Other personnel (e.g., drivers and supply personnel) affected by the change should also be consulted to ensure that sufficient local organizational support can be provided.

## **PROJECT IMPLEMENTATION**

Following project and funding approval, the implementation plan must consider the following issues which are discussed in Sections III, IV, and V.

1. Refueling Station
  - a. Design and Site Selection
  - b. Procurement
  - c. Installation/Test
  - d. Operations/Maintenance
  
2. Vehicle Conversion
  - a. Design
  - b. Procurement
  - c. Installation/Test
  - d. Operations/Maintenance

## **LIFE CYCLE CONSIDERATIONS**

The expected life of the CNG-vehicle conversion kits, except for the cylinders, is for the normal life of the vehicle (6 years). Fuel cylinders will normally have a longer life (15 to 20 years), depending upon their type of construction (steel, aluminum, or fiber-reinforced steel composite), and can be reused. However, fuel cylinders must be hydrostatically retested biennially according to the Department of Transportation (and Navy) regulations. The refueling station compressors also have a nominal life of 20 years. The economic life of some other refueling station components (e.g., the cascade vessels, system controls, and the slow-fill refueling field) is similar.

Some items (e.g., compressors) may be contaminated with oil and may require cleanup prior to disposal. However, oil contamination should be light, if at all, in other components. After cleanup they should be transportable to landfill for disposal or, better, sold as scrap for recycling (either aluminum or steel).

## **FUTURE AIR POLLUTION REGULATIONS**

Although no definitive commitment has been made by the automotive industry or the government to natural gas fuel, natural gas is growing in importance. In 1988, the production of natural gas exceeded, for the first time, oil production in the United States on an energy-equivalent basis. During the first 6 months of 1990, oil imports, for the first time, exceeded 50 percent of our total oil consumption (Ref 12). Also, a number of legislative and regulatory actions during the past year has encouraged the use of CNG and other clean fuels. Of greatest importance was the President's Clean Air Legislation which requires car makers to start producing clean-fuel-burning vehicles for sale in designated areas of the country. The bill also requires some urban areas to purchase clean-fuel buses on a specified schedule and requires fleets of government and commercial vehicles operating in ozone nonattainment areas to have clean-fuel capability.

Although the 1990 Federal Clean Air Act has now been passed, many of the ramifications of that bill are not yet clear. However, regardless of the final results of that legislation, specific areas of the country are continuing to move forward with regulations of their own to clean up the environment. California, for example, has passed laws to encourage the use of "clean" vehicle fuels (Ref 2 and 3) and the South Coast Air Quality Management District (Los Angeles area) is developing rules for the mandatory purchase of low emission vehicles by fleet operators (of 15 or more vehicles), starting in 1993 (Ref 4). Although the final requirements for clean-fueled vehicles are still being worked out, the Navy must prepare for increasing its use of alternatively fueled vehicles.



## SECTION III

### DESIGN

Construction and safety standards for the design and installation of CNG vehicle conversion kits and refueling stations are provided in the National Fire Protection Association (NFPA) Publication No. 52 (Ref 13). This document includes the requirements of other applicable codes by reference (see, e.g., Ref 14, 15, and 16) and serves as a basis for fire and safety officials to approve the construction and operation of CNG-vehicle fleet operations.

The American Gas Association (AGA) has also prepared a document (Ref 17 and Appendix D) that applies to CNG vehicle conversion kits and is intended to provide a procedure whereby CNG conversion kit manufacturers can receive AGA certification. However, to date, no kit manufacturer has been certified (one has recently applied). The railroad commission of the state of Texas has also instituted rules to establish qualifications for installers of CNG conversion kits, and California (Ref 18 and 19) requires that all CNG conversion kits be qualified for atmospheric emissions by the State Air Resources Board. All of the above standards are concerned with the construction and safety of CNG conversion kits and do not address vehicle performance. Therefore, it remains for the individual user (the Navy activity) to carefully specify the vehicle emission and performance standards that will be required, and to negotiate for them (contractually) from suppliers.

#### CNG VEHICLE CONVERSION KIT

In order to realize the full benefits of CNG-fueled vehicles, the converted vehicles must run acceptably and must have adequate CNG range. Meeting these fundamental requirements is critical because if either is lacking, operators, given a choice (i.e., for dual-fueled systems), will normally use gasoline rather than CNG. When that occurs the benefits of CNG operation are lost.

#### Conversion Kit Description

A schematic diagram of an installed CNG vehicle conversion kit was provided in Figure 1. The exact hardware items used may vary from vendor to vendor, but the following functional components should be included in each kit (see also Ref 13, 17, and 20).

- a. CNG storage cylinders, manufactured, inspected, marked and tested according to U.S. Department of Transportation (DOT) regulations, together with individual shutoff valves, mounting brackets and safety vapor seals.

- b. Appropriate pressure relief devices.
- c. A fuel supply line and required fittings that are designed for a bursting pressure four times that of the maximum working pressure.
- d. A fill adapter to accept CNG from the refueling station and a check valve to prevent the escape of CNG from the system.
- e. A pressure gauge mounted on the dashboard to indicate the quantity of CNG available in the storage cylinders.
- f. An electrical fuel selector switch to activate solenoid valves for choosing between gasoline and CNG fuels. The CNG solenoid valve must "fail-safe" closed when the motor is not in operation.
- g. A two (or more) stage pressure regulator to reduce CNG pressure from 3000 psi to near atmospheric pressure for injection into the engine.
- h. An air/CNG mixer for adjusting the CNG fuel/air ratio. The mixer is usually mounted on top of the gasoline carburetor in dual-fueled vehicles.
- i. An electronic ignition control system (dual curve) to optimize the efficiency and performance of the engine for both gasoline and CNG operating modes (recommended).
- j. Hour meters installed on each vehicle to track actual vehicle running times for CNG and gasoline operation (recommended).

### **Vehicle Performance**

A 5 to 15 percent power loss will often result when operating a vehicle on CNG rather than gasoline. Therefore, vehicles selected for conversion should have sufficient horsepower to offset the expected power loss. Four cylinder engines may, in some cases, not be good candidates for conversion. When a vehicle is tuned to run on both CNG and gasoline in a dual-fuel system, power loss can be mitigated by the use of dual-ignition-curve timing units.

### **Single or Dual Fuel**

For dual-fueled vehicles gasoline can be used when CNG is not available and vice versa. If the CNG-fueled vehicle fleet will be dependent upon a single CNG station (most are), possible breakdown or loss of power to the CNG compressor station may be a major factor in deciding whether to convert to single or dual-fueled operation. Compressor availability (i.e., compressor available time/total time) can be increased substantially if two (or more) small compressors (rather than a single large one) are used at the refueling station. A refueling station maintenance agreement requiring rapid response to breakdowns may also help to minimize the impact of compressor outage.

## **CNG Fuel Storage**

The fuel for a CNG vehicle is stored in specially qualified high-pressure cylinders, and manufacturers market several sizes to meet varying demands. The cylinders are rated at 2400 to 3500 psi and must be hydrostatically tested to 1-2/3 their listed service pressure at the time of manufacture. Current Department of Transportation (DOT) regulations require that the cylinders be retested every two years. Common capacities for the cylinders are 3 to 12 gallons of gasoline-equivalent CNG. Additional CNG tank data are provided in Table 5.

a. The range of CNG-fueled vehicles depends on the size and number of CNG storage cylinders used and the fuel usage rate (miles/gallon) of the vehicles. Sufficient CNG capacity should usually be installed to permit a full day's operation (100 mile range is adequate for most vehicles). For periodic trips out of the area dual-fueled vehicles can be switched to gasoline when the CNG tanks become empty.

b. The use of both fuels should not be anticipated on a daily basis. For regardless of the training provided, operators seem to resist continually switching between fuels. Further, if both fuels are used each day, both may need to be refilled each night. The result is that operators will often use that fuel which is the most convenient and which will last the entire day (usually gasoline). (Inadequate sizing of the CNG storage tanks in one CNG fleet led to the average consumption of CNG being reduced to less than 1 equivalent gallon per day per vehicle.)

c. The quantity of CNG storage desired and that which can be accommodated by a given vehicle is highly variable. Sedans have the greatest restrictions. Two 3-gallon tanks can normally be installed in the trunk and this may often be adequate for a day's operation. Most of the trunk space, however, is then lost for other purposes. Larger sets of tandem tanks (8 - 10 gallons total) can often be installed in pickups and small vans without excessive impairment of their usefulness. Large vans and buses can accommodate still greater storage (3 to 6 10-gallon tanks) on the underside of the vehicles. The latter installations can be expensive, but the resulting fuel savings can be considerable.

## **Fuel Pump**

In a dual-fuel system the mechanical fuel pump operates continuously, even while the vehicle is running on CNG. Therefore, in some cases, it may be advisable to install electric fuel pumps for dual-fuel vehicles. A small increase in engine efficiency is gained by removing the mechanical fuel pump, and an electric fuel pump makes the switch from CNG to gasoline easier. This is because an electric fuel pump fills the carburetor bowl faster and without cranking the engine. Installation of an electric fuel pump on the dual-fueled bus in the San Diego test fleet (see Appendix A) helped to improve performance of the bus and driver acceptance of it.

## **Fuel Use**

It is usually desirable to maintain records for the fuel used in each vehicle. An inexpensive and usually satisfactory method is to have time-of-use meters installed in each vehicle to track the amount of time that each fuel is used. Time-of-use data also provides an indication of operator driving habits, and when combined with odometer readings and fuel usage rates (miles/gallon) of the vehicles, provide good fuel-usage histories.

## **Quality Assurance**

It is the owner's (buyer's) responsibility to ensure that the CNG conversion kits are installed and operated in accordance with applicable safety and environmental regulations and that the vehicles operate properly. These requirements can be addressed by including the appropriate specifications, quality assurance and warranty provisions in a contract for the purchase, installation, and service of the installation kits (see Section IV).

## **CNG REFUELING STATION**

The specific requirements of each refueling station (total daily CNG consumption, number of vehicles to be serviced, delivery pressure, and the ratio of slow/fast fill), the utilities available (e.g., natural gas pressure), and the special configurations required for each station will, generally, be different. Therefore, each station must be tailored to meet the needs of the local CNG vehicle fleet.

## **Refueling Station Operator**

Several options are open to the local activity for acquiring CNG fuel for its vehicles. The activity may: (a) construct and operate its own refueling station, (b) contract with the local gas utility to build and maintain a CNG-refueling station for the activity, or (c) purchase CNG from a gas-supplier-operated-and-maintained CNG refueling station (utility or otherwise). The choice depends on (a) whether CNG fuel is available for purchase at another location near the activity, (b) the type of contract and prices that can be negotiated with the local utility (or a third party) for low-pressure or compressed natural gas, and (c) the capital available to the activity for implementation of a CNG-fueled vehicle fleet.

All three options have been used. If the capital is available, the potential for economic return to the Navy may be greater for an activity-funded-and-constructed refueling station. In all cases, negotiating a minimum gas price from the local utility is a crucial step in determining how each activity can most economically supply CNG to its fleet of vehicles. Utilities often have some flexibility in the prices that they can offer for CNG-fueled vehicles because of the special gas rates that can apply, and because they may have more than one way of amortizing the costs of refueling stations. If the charge that public works adds to the cost of natural gas delivered at the activity is high, that can be a critical factor in determining the economic payback for the CNG system.

See Section II for Physical Resources.

## Refueling System

The refueling system (Figure 2) draws natural gas from the natural gas supply into the suction side of a compressor for pressurization and delivery either directly to the vehicles or to storage containers. Direct, simultaneous filling of many (>4) vehicles may require several hours and is termed "slow-fill." The storage containers are not normally used in this operation. When the CNG is dispensed to the vehicles from the storage containers (or directly from a large capacity compressor) the procedure is known as "fast-fill." Four to 8 minutes are required to fill a vehicle.

The storage system can be of two types: bulk or cascade. Bulk storage can involve either a single large container, or several smaller containers manifolded together. As vehicles draw CNG from bulk storage, the pressure in all containers is reduced at the same rate. Cascade storage is arranged in banks of containers each manifolded together, but separated by switching valves so that each bank acts as a single container. Vehicles are filled from the cascade by a sequential tapping of the various banks; i.e., the bank with the lowest available pressure is called upon first and the bank with the highest pressure is called upon last. A cascade system provides more "available" storage than a bulk system for the same size containers, but a cascade system costs more. For small fleets of vehicles (15 or less) a fast-fill station with two drop hoses may be adequate. For larger fleets, CNG storage requirements, compressor size, maximum fueling rates, and compression costs increase so that a slow-fill capability may become justified.

Figure 4 shows elements of the compressor station. Several options that can be pursued in its design are: (a) compression with no storage (fast-fill only), (b) compression with storage (fast-fill only), (c) combination fast-fill/slow-fill (including storage), and (d) slow-fill only (no storage). The major design factors are: (a) the total daily CNG consumption, (b) the number of vehicles to be refueled and their schedule for refueling, (c) the maximum required delivery rate over a limited period of time (e.g., 1 hour), and (d) the supply pressure of natural gas. The major cost components that must be evaluated (see Table 6) are: (a) the compressor along with necessary controls and accessory equipment, (b) CNG storage tanks (cascades), (c) fast fill dispensing equipment, and (d) the slow-fill refueling field. Capital cost is minimized with slow-fill, only. For slow-fill, the size of the compressor is minimized and storage tanks are not required. Operational costs are also reduced as the compressors would normally operate during nighttime hours when electrical power for compression is lowest. However, some fast-fill capability is almost always needed at any refueling station.

Consider a 50-vehicle fleet in which the average vehicle uses 7.0 gallons of fuel per day (see Tables 6 and 7). For an available gas pressure of 5 psi, a compressor delivering 50 CFM produces 3000 CFH (approximately 27 gallons, equivalent per hour). This compressor could supply CNG to refuel 3.9 vehicles per hour (Case 2) but would require 13.0 hours to refuel all of the 50 vehicles. As vehicles could not afford to wait in line, fast-fill would not be an acceptable alternative. A typical 9000 ft<sup>3</sup> storage cascade (20 bottles at 450 ft<sup>3</sup>/bottle) contains

sufficient CNG to fill 3.9 vehicles (about 1/3 of the total capacity of the cascade, or 3000 CF, is usable for refueling) before the cascade has to be recharged. Although several cascades could be installed so that a greater number of vehicles could be fast-filled (Case 3), storage is expensive (about \$13K per cascade, installed). Six cascades providing 164 gallons of useful storage (sufficient to refill 20 vehicles) would cost \$78K, so that the total installed cost for the station would be \$146K.

The cost for a slow-fill field fueling 36 vehicles (at about \$700.00/vehicle stall) would be about \$25,000. This would bring the total installed cost to about \$103K (Case 4).

The questions of scale and system reliability also need to be addressed (Case 5). For this application either a single 50-CFM compressor or two 25-CFM compressors could be used. Although the cost of the single compressor is significantly less than that of a two-compressor installation (\$60K versus \$85K), the flexibility and reliability of operation provided by the two-compressor installation is usually desirable. The latter may be the best of the alternatives for a low-pressure gas supply.

When the gas supply pressure is 50 psi or greater (Case 6), a compressor delivering 100 CFM can be installed for a cost similar to that for Case 5. At this or a slightly greater delivery rate (55 gallons/hour), direct refueling of the vehicles from the compressor without the use of storage cascades starts to become feasible. However, compressor operating costs may also increase as most compression would probably occur during peak-electrical-rate hours.

### **Service Station Metering**

A common method of determining the quantity of CNG transferred to a vehicle is by measurement of the ambient temperature and the vehicle's storage tank pressures prior to, and following, the fill operation. Given the liquid volume of a CNG storage tank, its capacity for storing CNG (in standard cubic feet, SCF) can then be determined for any combination of temperatures and pressures (see, e.g., Table 8). Therefore, recording the temperature and pressure at the start and end of a fill operation allows calculation of the amount of CNG added, by difference. This is the only feasible way of monitoring the quantity of CNG added to each vehicle during "slow-fill."

For fast-fill, commercial CNG "pumps" similar to those commonly seen in gasoline stations are also available (see Figure 5 for photographs of an automatic CNG dispenser). However, their high cost (\$15,000 - \$20,000/per hose, installed) may limit their usefulness. Therefore, manual fast-fill fueling posts with measurement of tank pressure readings prior to, and following, a fill operation will probably continue to be an important method for many fast-fill operations, as well. This method should also meet the requirements of NAVFAC P-300 (Ref 5) for fuel accountability which states that "procedures shall be established... to ensure adequate fuel accountability... fuel issues vary from totally manually operated to fully automated system." A four-vehicle slow-fill fueling post is also shown in Figure 5. Estimates of CNG usage can also be made using readings from vehicle time-of-use meters, odometer readings, and vehicle fuel usage rates (miles per gallon).

## **IMPACT ON EXISTING DOCUMENTS**

NAVFAC P-300, "Management of Transportation Equipment" prescribes management procedures for Navy vehicles. As vehicles converted to CNG operation are considered to be "modified" (at this time they are still not available as "manufactured" vehicles), they are not addressed directly in that document. However, as CNG-fueled vehicles become available from automobile manufacturers and as experience is accumulated in their use, operation management and maintenance procedures that prove important should be incorporated into NAVFAC P-300.

## SECTION IV PROCUREMENT

### CONTRACTING APPROACH

#### Recommendation

It is recommended that all CNG procurement requirements be included into a single solicitation to simplify the contracting effort and to place full responsibility for contract performance upon a single contractor. In some cases, however, local circumstances may dictate that separate solicitations for the CNG vehicle conversion kits and for the refueling station be undertaken. Therefore, Appendix B provides sample contract documents that can be adapted to local procurement requirements using either of the above approaches.

#### Procurement Responsibility

Although TEMC and NCEL can provide technical support for the acquisition of a CNG-fueled vehicle fleet, the responsibility, to date, for procurement of the fleet and refueling station is with the individual Naval activities. Therefore, decisions regarding the contracting approach and the solicitation effort should be made to reflect local procurement requirements and practices. The information included here is intended as guidance to assist Naval activities in understanding the possibilities for procurement of CNG-fueled vehicles and to provide background data that will be useful in carrying out a successful contract effort. It does not provide a precise definition of the content of a solicitation package. [Note: procedures for procurement of CNG-fueled vehicles supplied by original equipment manufactures are not included; those vehicles are not yet available].

### GENERAL GUIDANCE

#### Contract Items

Once the decision has been made to convert conventionally fueled (gasoline) vehicles to CNG, the Navy activity should contract for any, or all, of the following:

- a. Vehicle conversion hardware and installation and checkout services, including warranties.



b. Refueling station hardware and installation and checkout services, including warranties.

c. CNG Vehicle and refueling station maintenance for a period of one year (with annual renewable options), including spare parts and support and test equipment (S&TE) for use by the contractor (except GFE).

d. Operation and maintenance documentation, S&TE lists, parts lists, training materials suitable for government use following the (1 year) contractor support period, and other contract data as required.

e. Vehicle and refueling station operation and maintenance training for government personnel, to include classroom and hands-on training during conversion/installation, and during the (1 year) contractor support period.

### **Considerations**

**CNG Vehicle Conversion Kit.** CNG-fueled vehicle conversion kits are available from a growing number of suppliers (see Appendix C). However, as the design, assembly, and installation of these conversion kits is a relatively new commercial activity, their performance and reliability are not of the uniformly high quality normally expected from the automobile industry. The conversion kit standard developed by the AGA (see Appendix D) may be helpful and could be included in any procurement document either by reference, or as a requirement for AGA certification for potential suppliers. However, that standard has not yet been used (no certifications have yet been issued) by the AGA. Further, the standard is not complete, from the user's point of view, in that vehicle performance requirements are not addressed. Therefore, the purchaser must take special care in assembling a procurement package and in selecting a supplier who will be able to provide good technical design, good vehicle performance, and the capability and financial resources to provide adequate post-installation support (services and spare parts). Without a carefully developed acquisition plan it is likely that neither the promised economic savings nor a satisfactorily operating CNG vehicle fleet will be realized. (Note: Of the three CNG conversion kits evaluated during Navy field tests (see Appendix A), two worked satisfactorily. Of those, only the IMPCO kit is still commercially available).

**CNG Refueling Station.** It may be tempting for a Navy activity to design, fabricate and/or install its own CNG refueling station. Except in unusual circumstances, however, this function should be left to a contractor with the specialized expertise necessary for proper design and for meeting standards of safety in handling high-pressure natural gas.

**Contractor Support.** During the first year (or longer, if necessary) following completion of conversion/installation of the CNG kits, the Navy activity may require and, therefore, should provide for contractor maintenance support. This period should allow time for the establishment of in-house maintenance, training, and supply capabilities while assuring proper maintenance during the critical adjustment period. It

is recommended that in-house personnel participate in and witness vehicle conversions, refueling station installations, and first-year repairs as a way of supplementing formal operation and maintenance instruction given by the contractor.

**Warranties.** Warranties for materials, workmanship, performance of the vehicles with CNG conversion equipment installed, and conformance of operating vehicles to applicable federal and local regulations (see Section III) must be obtained from the manufacturer of the conversion kit (and the installer, if two or more companies are involved).

**Maintenance Agreement.** The maintenance agreement could include a maximum response time and a guarantee of a minimum availability of the refueling station. A performance bond to ensure the required performance could be included.

**Government Furnished Property (GFP).** A list of the equipment required for installation of the CNG conversion kits is provided in Table 9. The solicitation package and contract should clearly identify which, if any, of these items will be provided by the government for the contractor's use during his installation, maintenance, supply and training efforts.

**Quality Assurance.** Special attention should be given to the development of, and adherence to, the quality assurance provisions in each of three areas:

a. **Hardware Supplied and Craftsmanship of Installation.** The local command will become responsible for inspecting and accepting the "CNG products" delivered to the Navy by the vendor. Therefore, it is recommended that local personnel become intimately familiar with the requirements of NFPA No. 52 (Ref 13) in order to develop a rational basis for judging the quality of materials and craftsmanship of installation that will be acceptable.

b. **Performance of the Installed Equipment.** Vehicle performance can be described by: (1) power delivered at given vehicle speed(s) as measured by dynamometer, (2) conformance of vehicle to environmental, safety, and other regulatory standards, and (3) adequate CNG tankage to provide for a specified range of the vehicle. Acceptable performance thresholds can be specified and verified at both time of delivery and at some date following date of delivery. The latter is to ensure that unacceptable degradation of vehicle or refueling station performance does not occur (see Appendix B for examples of performance standards). Vehicle dynamometers are available at most Navy PWCs/PWDs and are getting increased use to assist with adjustments of emission controls. If one is not available on site, other arrangements should probably be made to verify vehicle performance before and following conversion.

c. **Service to and Maintenance of the Operating Equipment.** The requirements for vendor support must be carefully developed and described for both the training of operators and maintenance personnel and the provision of maintenance services and spare parts.

## SECTION V

### OPERATION AND MAINTENANCE SUPPORT

#### SUPPORT CONCEPT

Operation and maintenance of vehicles fueled by CNG, as well as CNG refueling stations, will be carried out under normal logistics systems that serve conventionally fueled vehicle fleets and dispensing stations. (see NAVFAC P-300, Ref 5). While planning and introducing the CNG equipment (vehicles and refueling station), the Navy activity must update its programs for both operation and maintenance to address the unique CNG support requirements. CNG-related maintenance will be performed within the normal activity maintenance levels to include Organizational (vehicle operator), Intermediate (maintenance personnel), and Depot Level Maintenance. Normally, Naval shore activities perform maintenance at the Organizational and Intermediate Maintenance Levels; Depot Level maintenance that includes the overhaul of engines and other designated repairable vehicle components is generally carried out under contract to commercial activities.

#### OPERATION AND ORGANIZATIONAL LEVEL MAINTENANCE

##### Vehicles

Vehicles fueled by CNG will be operated and maintained at the Organizational Maintenance Level (1st echelon), by operators who perform similar tasks for operation and maintenance of conventionally fueled vehicles under the provisions of NAVFAC P-300.

To operate vehicles fueled by CNG, operators must become familiar with procedures for CNG refueling, for starting CNG vehicles, and for switching fuels when operating a vehicle with a dual-fuel capability.

As with conventional vehicles, CNG maintenance by operators is generally limited to inspections and reporting.

##### Refueling Station

While operating the CNG refueling station, operators will be responsible only for attaching and operating the refueling station wands. They will not be responsible for any maintenance on the refueling station. However the vehicle operator should observe and report any CNG dispensing station problems that require action at a higher maintenance level.

## **INTERMEDIATE LEVEL MAINTENANCE**

### **Vehicles**

Vehicle maintenance beyond the capability and responsibility of the vehicle operator will be performed by vehicle mechanics, already trained and otherwise qualified to perform Intermediate Level Maintenance (2nd Echelon) on conventionally fueled vehicles under the provisions of NAVFAC P-300. With the addition of the CNG capability, the responsibility of the vehicle mechanic is extended to include all CNG equipment maintenance above the 1st echelon (operator) capability and short of Depot (3rd Echelon) maintenance actions related to overhaul of the vehicle or designated vehicle components.

### **Refueling Station**

Maintenance of the refueling station will be the responsibility of Public Works.

## **DEPOT LEVEL MAINTENANCE**

### **Vehicles**

In accordance with existing NAVFAC policy for all Civil Engineering Support Equipment (CESE), Depot level maintenance will not be performed on transportation vehicles fueled by CNG unless restoration is specifically approved by NAVFAC. This maintenance includes the overhaul of engines and other designated vehicle components, and is generally contracted out to commercial activities. CNG expertise and capability should be considered in selecting commercial activities for engine overhaul.

### **Refueling Station**

Maintenance requirements for the refueling station can sometimes be met by the Intermediate Level capability within Public Works. Otherwise, that maintenance must be contracted out to a commercial activity. Requirements for compressor repair or restoration requiring Depot Level attention will, generally, be contracted out to a commercial activity as part of the original solicitation.

## **PERSONNEL AND TRAINING**

### **Personnel**

No additional quantities or new classifications of personnel are required for operation and/or maintenance of CNG fueled vehicles and refueling stations, although some new training is required. Personnel directly involved with the CNG equipment are vehicle operators, vehicle mechanics, and Public Works facilities maintenance personnel responsible for maintenance of the refueling station.

## **Operator Training**

Prior to operating CNG fueled vehicles, operators will receive supplementary "difference" training that addresses unique CNG operation and operator-level maintenance procedures and responsibilities. This training is key to satisfactory vehicle performance and operator acceptance of the CNG fueling concept. Safety issues unique to CNG systems should be thoroughly explained during the training. The Navy activity can plan and carry out the operator training program using resources available within the government, via contract, or with a mix of government and contractor capabilities.

## **Vehicle Mechanic Training**

One of the most important ingredients of a successful CNG operation is a properly trained vehicle maintenance crew that is positively oriented toward the use of CNG. Maintenance training is available from equipment suppliers and should be contracted for, initially. Follow-on training can be provided as a supplementary "difference" course either by contract or by using in-house training capabilities. Maintenance training will include the fundamentals of CNG vehicle operation, and will be directed, primarily, at CNG vehicle conversion and maintenance of the vehicles. Safety issues unique to CNG systems must be addressed and thoroughly explained in the "difference" course(s).

## **Other Personnel Training**

Public Works personnel must be trained in the maintenance of the refueling Station. The supplier should provide this training initially, with follow-on training to be provided by in-house capabilities planned and developed by the Navy activity. Compressor maintenance is the primary requirement. Safety considerations must be thoroughly explained during training.

## **DOCUMENTATION**

CNG-unique Operation and Organizational/Intermediate Level maintenance tasks and procedures relative to CNG vehicles and the refueling station should be included in the Operation and Maintenance (O&M) manuals supplied by the contractor, along with vehicle conversion kits and the refueling station. The Navy activity (with the assistance of TEMC if necessary) should break out and document these tasks and procedures according to the responsible maintenance level and the requirements of NAVFAC P-300, Management of Transportation Equipment. Tasking and procedures should address inspection and maintenance of refueling station compressors and cylinders, vehicle conversion, and the more routine tasks for vehicle troubleshooting, lubrication, parts replacement, heat control, and planned maintenance. CNG-related information to be considered in the development of standard-type vehicle O&M documentation are:

1. Tune-up frequency and procedures, except for an adjustment in the fuel-air mixture and timing, should be the same as before the CNG conversion.

2. Engine oil should, initially, be changed on the same frequency as before the CNG conversion. Maintenance data can be collected and analyzed periodically, to determine if any adjustment can be made to the frequency of oil changes. Unless capability for oil analysis resides within the Navy activity, this service could be requested as part of the original solicitation. CNG engines burn cleaner. The positive effect of cleaner burning will offset the negative effect of the additional heat, which tends to diminish the lubrication and cooling properties of engine oil.

CNG-related maintenance tasks may be either of a preventive or corrective nature, and should be documented by maintenance personnel. Preventive Maintenance (PM) includes those measures developed, documented, and scheduled as necessary to maintain equipment in a high state of readiness and resistance to breakdown. NAVFAC Form 9-11240/13, used by operators as a guide for inspection before and after vehicle use, should be updated to include checks recommended by the equipment Operation and Maintenance (O&M) manuals. Corrective Maintenance (CM) includes those measures necessary to restore equipment to a serviceable condition when a breakdown occurs.

This UDP does not have as its purpose the definition or documentation of CM and/or PM requirements and procedures. Such details are provided in supplier-furnished O&M manual(s) and/or other Navy activity maintenance and management documentation. Because CNG engines are cleaner burning than conventionally-fueled engines, it is claimed by many that less PM will be required. However, this conclusion has not been universally substantiated. Corrective maintenance, in some cases has ranged from persistent loss of power (see Appendix A) to increased frequency of major overhauls.

Overheating, in some cases, has led to loss of power, blown head-gaskets, starting problems, and increased frequency of overhaul. In other cases reduced frequency of oil changes, reduced corrective maintenance, and good vehicle performance have been reported. These divergent results leaves one to conclude that the standards for installation and maintenance of CNG kits are probably not uniform. They also emphasize the need for proper vendor selection for the kits, and for development of an adequate maintenance program. Therefore, those PM tasks that have been identified should be properly scheduled, carried out and reported, and CM tasks should be carefully documented under the guidance of NAVFAC P-300.

## **REPAIR PARTS AND CONSUMABLES**

CNG refueling station and vehicle maintenance depends upon the ready availability of replacement items, whether required under a replacement schedule or for random repair of malfunctioning or inoperative equipment. Some data are available in the literature (Ref 10) regarding repair frequencies of kit components, but each suppliers kit is different and this

data cannot be considered to have universal application. Therefore, it is recommended that suppliers of equipment for the refueling station and the conversion kits be required to identify and furnish an initial selection of spare items to cover an initial period of time (1-2 years). The Navy activity will calculate the requirements for replenishment and/or follow-on items and take follow-up procurement action to assure that the required items are stocked locally in anticipation of need.

### **SUPPORT AND TEST EQUIPMENT (S&TE)**

CNG refueling station and vehicle maintenance depends upon the ready availability of Support and Test Equipment (S&TE) (see Table 9). Suppliers of equipment for the refueling station and the conversion kits must be required to identify any general or special purpose S&TE in their proposals. These should then be identified, contractually. The Navy activity will follow through to calculate S&TE shortages, procure the required items initially, and assure any necessary replenishment as well. S&TE may be required for vehicle and refueling station Intermediate Level (Vehicle Mechanic/Public Works) maintenance only. None will be required at the Organizational Level for use by the vehicle operator. The S&TE items, identified generically in Table 9, should be confirmed/identified, procured, stocked, and managed in support of the intermediate maintenance operation.

### **FACILITIES**

Aside from the refueling station (which is considered an element of the system equipment) and temporary stalls for installation of the vehicle conversion kits, there are no new facilities required for operation and/or maintenance. The CNG project does not increase the number of vehicles owned by the Navy activity, and thereby introduces no additional burden for operational storage or maintenance shops.

### **PACKAGING, HANDLING, STORAGE, AND TRANSPORTATION (PHS&T)**

In general, CNG refueling station and conversion kit components are relatively small, light, compact, and low in quantity. Except for CNG storage cylinders, there are no unique or demanding requirements for Packaging, Handling, Storage and Transportation (PHS&T). Storage cylinders used in the CNG operation vary in weight and dimensions, as shown in Table 6. The cylinders must be manufactured, inspected, marked and tested by the supplier in accordance with U.S. Department of Transportation regulations, exemptions, or special permits issued specifically for CNG service. These cylinders are the property of the local activity which become responsible for periodic hydrostatic retesting of them. The latter can be performed by local personnel (Ref 21).

Once installed, whether in the refueling station or on a vehicle, the cylinders are a fixed item and do not require frequent handling. Occasions will occur, however, when they must be removed, exchanged, or

otherwise handled for shipping or storage. Their weight and bulk may require the use of a forklift for handling one or more cylinders. Cylinders making up the cascade bank are assembled onto a steel pallet storage rack, which allows the cascade to be moved by forklift as a unit.



## SECTION VI

### ACKNOWLEDGMENTS

Several people contributed to this project. Mr. Doug Dahle initiated it. Ms. Karen Miller continued with it and did much of the work on the test project at Public Works Center (PWC), San Diego (see Appendix A). PWC San Diego provided operational and mechanical support for the test vehicles (Maintenance Supervisors Marion Irish and Pete Boozel, and Mechanics Earl Disney and Chris Shafers). Mr. Mike Villegas summarized CNG operations at several government activities. Mr. Rudy Hardy and Mr. Vic Volpe prepared Sections IV and V of this document.

## SECTION VII

### REFERENCES

1. "Negotiators complete clean air bill," Michael Ross, Los Angeles Times, 23 Oct 1990.
2. California Assembly Bill 234 (1987).
3. "Strict new anti-smog rules OK'd for autos," Larry B. Stammer, Los Angeles Times, 29 Sep 1990.
4. South Coast Air Quality Management District. Proposed Rule No. 1601: "Fleet conversion for passenger light-duty, and medium-duty vehicles," El Monte, CA (Hearings will continue in Fall, 1990).
5. Naval Facilities Engineering Command. Publication 300 (NAVFAC P-300): "Management of transportation equipment," Jun 1989. (Order through U.S. Naval Publication and Forms Center, 5801 Tabor Avenue, Philadelphia, PA 19120, A/V 442-3321, Commercial 215-697-3321, SN: 0525-LP-318-0700).
6. Application of San Diego Gas & Electric Company (U 902-G) for an Ex Parte order granting authority to increase revenue requirements to support a new natural gas vehicles (NGV) program; to implement adjustment clause treatment for new NGV program expenditures; and to recover increased revenue requirements in rates; or in the alternative to establish a tracking account for such expenditures, 11 Jun 1990.
7. Jeff Seisler. Telephone conversation, Natural Gas Vehicle Coalition, 27 Mar 1990.
8. Brian O'Donnell. Telephone conversation, Arizona Public Utilities, Phoenix, AZ, 3 May 1989.
9. Jeffrey M. Seisler. "Toward commercialization of natural gas vehicles," American Gas Association Market Development, Mar 1984.
10. Jack Hart. Telephone conversation, Automotive Natural Gas, Inc. Milton, WI, 4 May 1989.
11. Roger Ward. Panel participant and marketing manager for General Motors Truck Division, "Dedicated NGV technology," and personal conversation with Norman L. Helgeson, NCEL, Code L74, at Natural Gas Vehicle Conference, Washington, D.C., Sep 20-22, 1989.

12. Energy Report, vol 18, no. 29, 23 Jul 1990.
13. National Fire Protection Association. "Compressed natural gas (CNG) vehicles fuel systems," Publication No. 52, Batterymarch Park, Quincy MA 02269.
14. \_\_\_\_\_. NFPA 70-1984: "National electrical code," Batterymarch Park Quincy, MA 02269.
15. American National Standards Institute/American Society of Mechanical Engineers. ANSI/ASME B31.3: "American national standards code for chemical plant and petroleum refinery piping," (1980).
16. American Society of Mechanical Engineers. "Rules for the construction of unfired pressure vessels," Section VIII (Division 1), ASME Boiler and Pressure Vessel Code.
17. American Gas Association Laboratories. "AGA requirements for natural gas vehicle (CNG) conversion kits," No. 1-85, 8501 East Pleasant Valley Road, Cleveland, OH 49131, 20 Aug 1985, (see Appendix D).
18. State of California Air Resources Board. "Approved LPG and CNG conversion systems," 1 Dec 1988.
19. \_\_\_\_\_. "California exhaust emission standards and test procedures for system designed to convert motor vehicles to use liquefied petroleum gas or natural gas fuels," 14 Sep 1984 (Amended).
20. Robert W. Sprague. "National fuels experience with the installation, maintenance and repair of CNG vehicles," in Symposium on Nonpetroleum Vehicles Fuels V, Ed. by Donald L. Klass and Jeffrey M. Seisler, Apr 9-12, 1985.
21. Compressed Gas Association. "Methods for testing of compressed gas cylinder," 1235 Jefferson Davis Highway, Arlington, VA 22202, 1978.

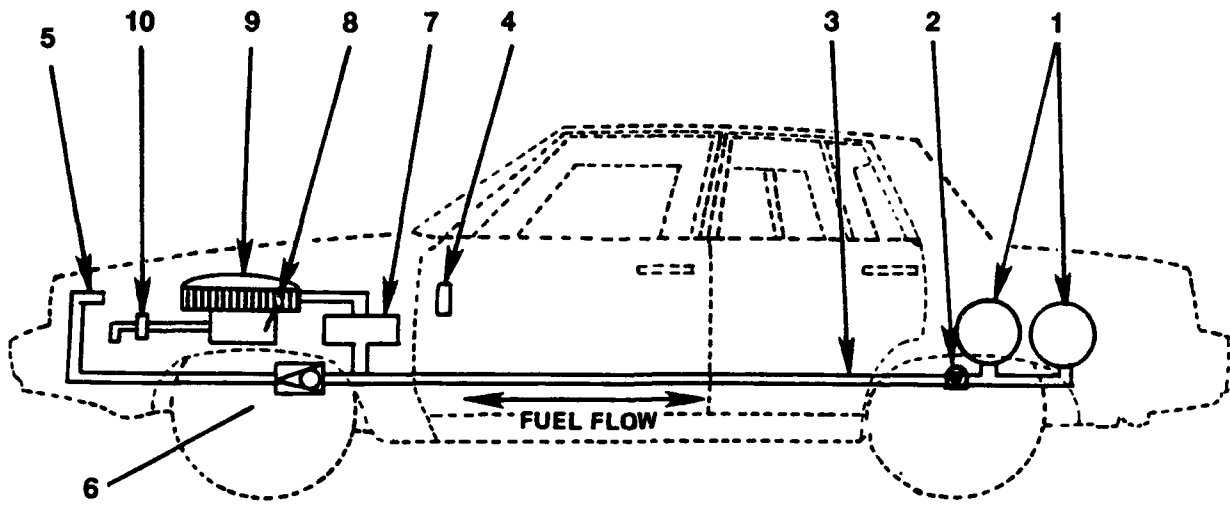

- (1) natural gas cylinders
- (2) manual shut-off valve
- (3) high pressure fuel line
- (4) fuel selector switch and gauge
- (5) natural gas fill valve
- (6) check valve
- (7) pressure regulator and natural gas solenoid valve
- (8) original equipment gasoline carburetor
- (9) natural gas mixer
- (10) gasoline solenoid valve

Figure 1. Schematic diagram showing CNG conversion kit installed in a sedan.

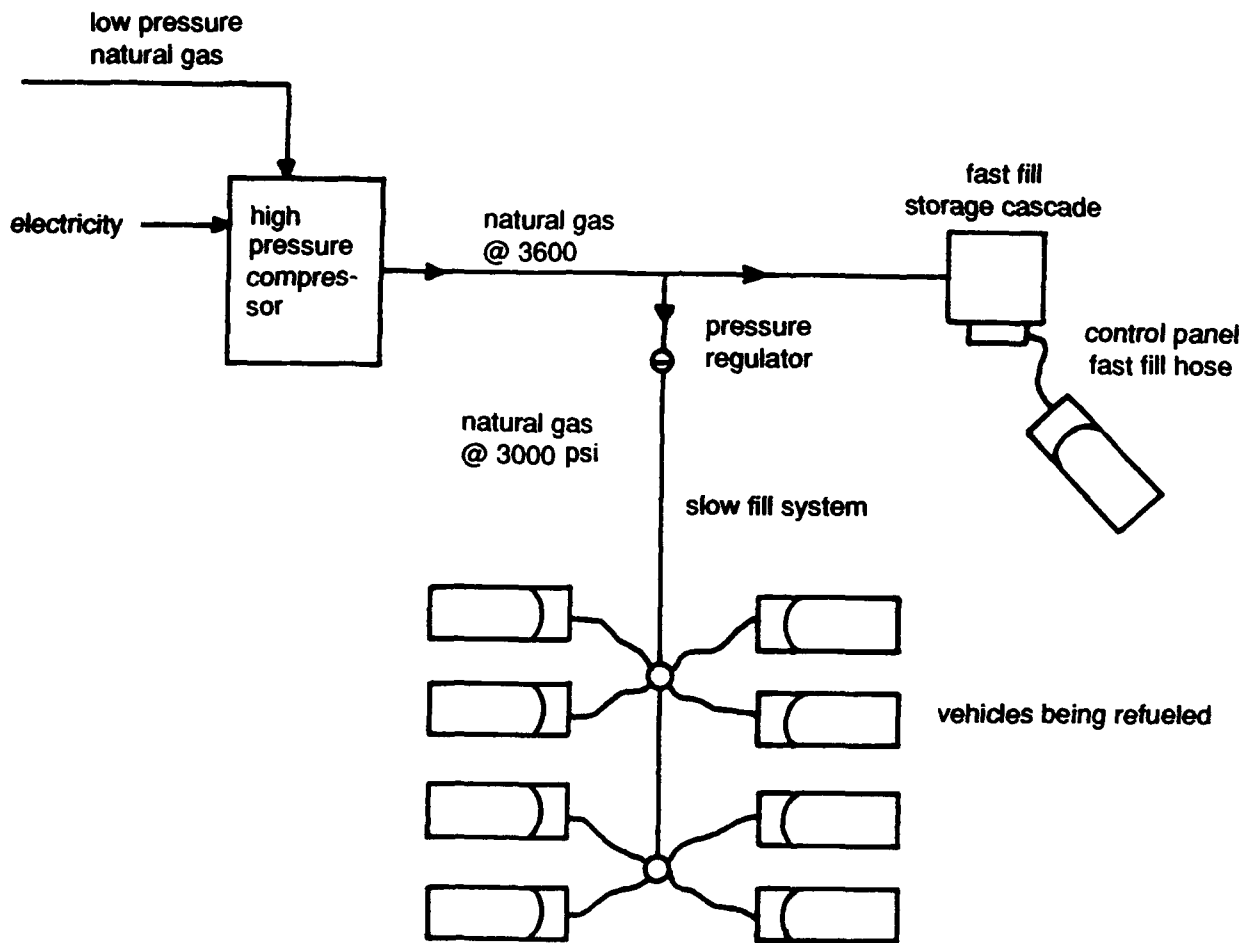
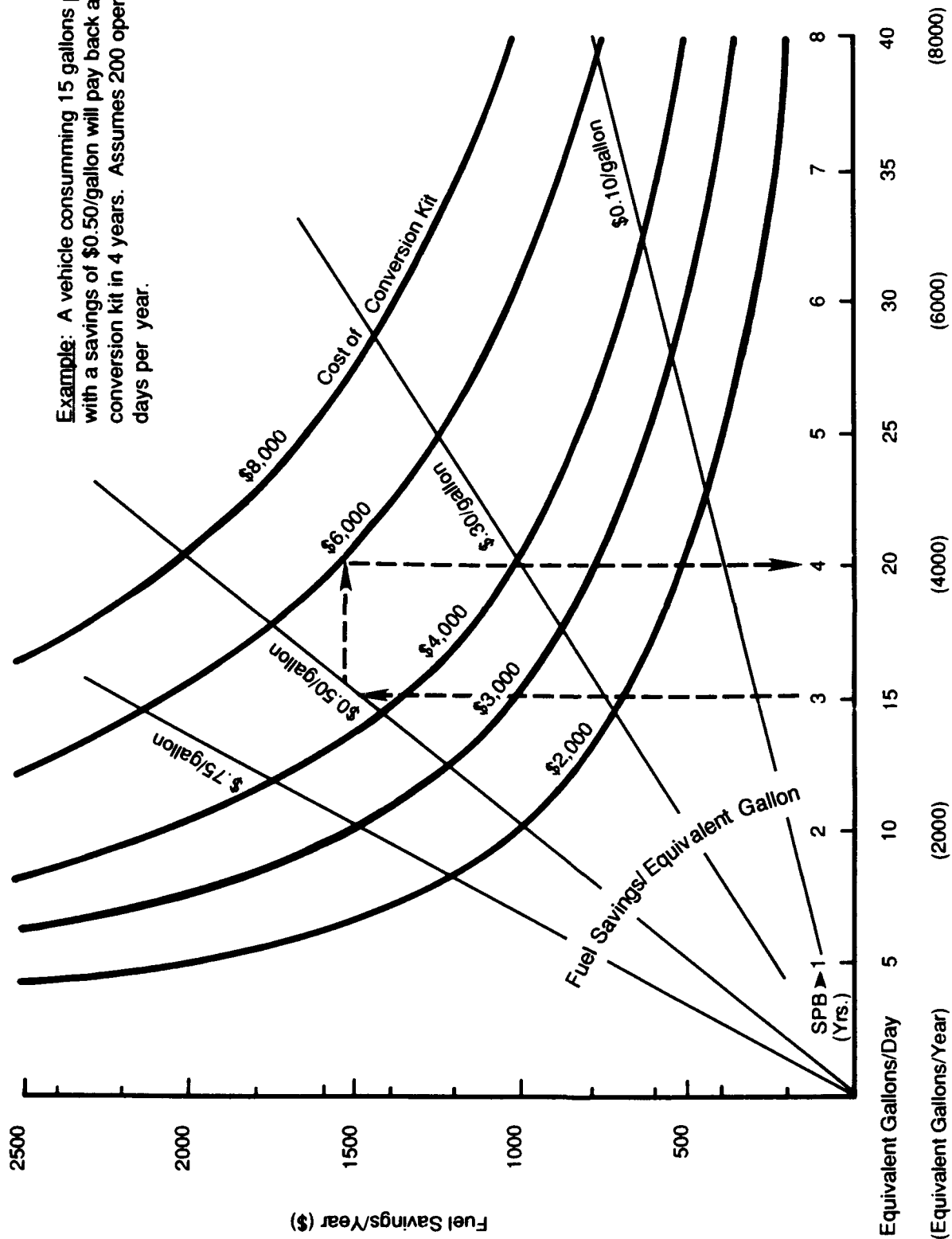

Figure 2. Components of a compressed natural gas (CNG) refueling system.

**Example:** A vehicle consuming 15 gallons per day with a savings of \$0.50/gallon will pay back a \$6,000 conversion kit in 4 years. Assumes 200 operating days per year.



**Figure 3.** Simple pay-back of CNG vehicle conversion kits based on quantity of CNG used and on the price differential between gasoline and CNG.

1. Connection to natural gas supply
2. Compressor.
3. Methanol injector to prevent ice formation from traces of water in natural gas.
4. Cascade of CNG storage cylinders for fast-fill.
5. Valve sets to prioritize withdrawal of CNG for filling vehicles.
6. Refueling hoses.

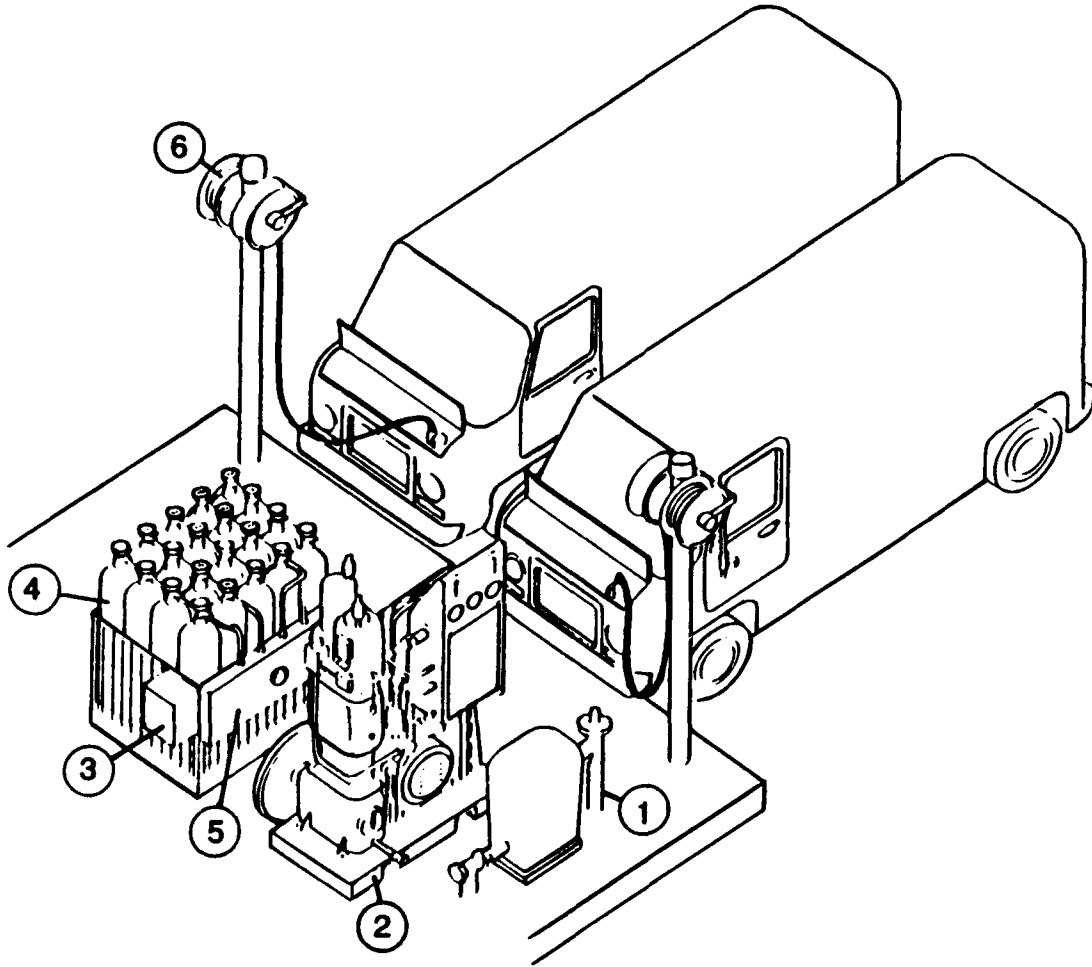
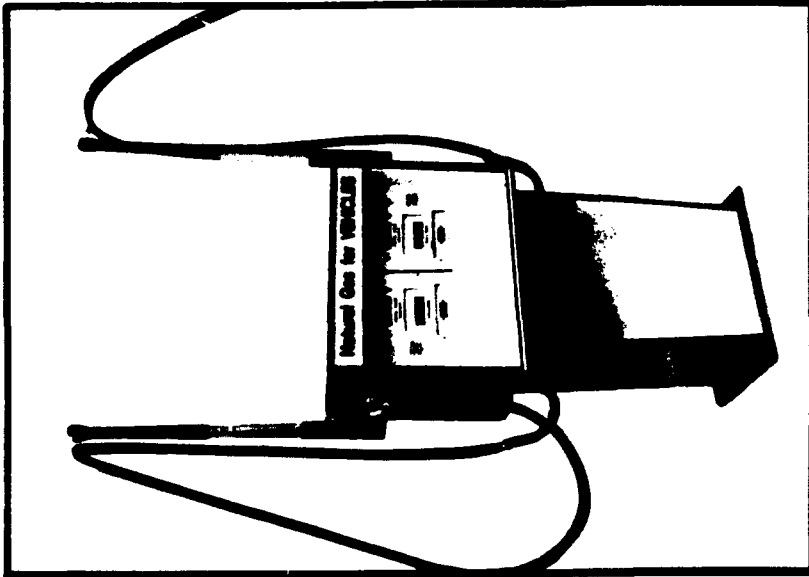

Figure 4. Compression and CNG storage equipment for CNG refueling station.

## Automatic Dispenser



Fully automatic.  
Reads in dollars/therms.  
Single or twin hose.  
Conforms to NFPA-52.

## Fueling Post

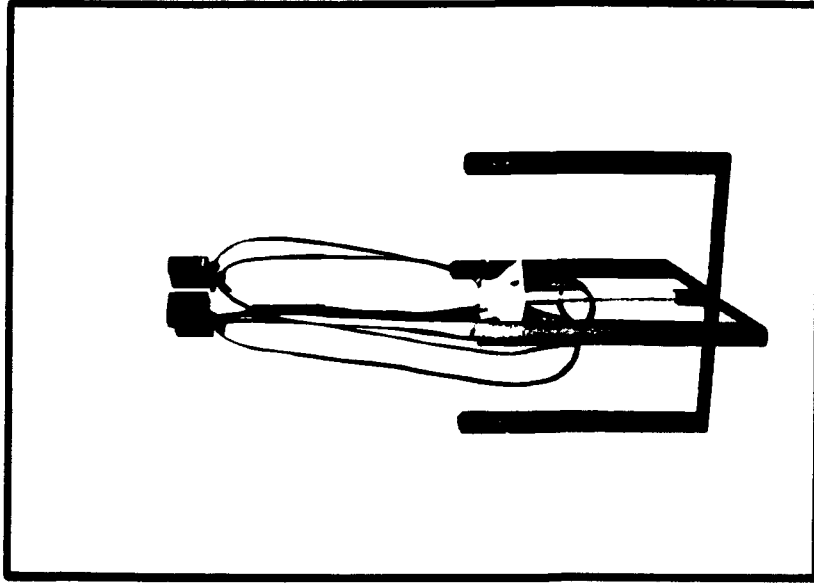

Typical fueling post for serving four vehicles simultaneously. Includes base, barricade posts, shut-off valve, quick coupler break-away system and hose and hose retractor for each hose.

Figure 5. Photographs of CNG automatic dispenser (fast-fill) and four vehicle fueling post (slow-fill).



Table 1. Estimated Cost of Equivalent  
Gallon of CNG (Example)

	<u>Lo-Pressure*</u>	or	<u>High-Pressure**</u>
Cost of natural gas (\$/therm)	<u>.35</u>		<u>.70</u>
Public Works Charges (\$/therm)	<u>0.10</u>		<u>.10</u>
Cost of Compressor (\$/therm)	<u>0.05 (est)</u>		<u>None</u>
Compressor Sta. Maint. (\$/therm)	<u>0.08 (est)</u>		<u>None</u>
State Vehicle Fuel Tax (Several states have passed laws exempting CNG used in vehicles from a road tax).	<u>None</u>		<u>None</u>
TOTAL (\$/therm)	<u>0.58</u>	or	<u>.80</u>
Conversion factor (\$/therm to \$/equivalent gallon of CNG)	X 1.1		X 1.1
Cost/Equivalent gallon (\$/Gallon)	<u>0.64</u>	or	<u>0.88</u>

\* Low-pressure is defined as  $\leq 30$ . psi

\*\* High-pressure is defined as 3000. psi

Table 2. Criteria for Selection of Vehicles  
for Conversion to CNG Operation

The following criteria should be used in selecting candidate vehicles for conversion to CNG operation.

1. Until there is more widespread use of CNG, CNG-fueled vehicles are best suited to vehicle fleets that operate in the same locale each day. This allows the vehicles to return to the CNG refueling station each night.

2. A minimum of 5 gallons per day (and preferably 7-8 gallons per day) of fuel should be used by a vehicle per operating day in order for it to provide a reasonable ( $\leq 6$  yrs) SPB for installation of the CNG conversion kit. (See Table 3)

3. Although most components of the CNG-vehicle conversion kits can be reused, the tanks are, generally, the only items for which reuse is economically feasible.

4. The selected vehicles must have sufficient horsepower to overcome an anticipated drop in performance (5-15 percent horsepower) while operating on CNG.

5. Passenger cars (single or dual-fueled) are sometimes difficult to convert to CNG operation because there is little room for mounting the storage cylinders.

6. Pickup trucks are relatively easy to convert to CNG operation because there is good room in the engine compartment for the conversion equipment and because the CNG storage cylinders can often be mounted in the truck bed.

7. Vans are more difficult to convert because they have small engine compartments. Storage cylinders placed inside the van must be bagged and vented to the outside (see Reference 12). However, the cylinders for large vans can sometimes be carried under the vehicle body.

8. Passenger buses have sufficient room in the engine compartment for the conversion equipment and sufficient space for CNG storage under the chassis to provide a range of several hundred miles.

9. Candidate vehicles include:

Sedans

Pickups and Vans

Stake and Platform Trucks

Buses

Medium trucks, 6 cylinders or more exceeding 1/4 ton.

Vehicles operated within 60-65 mile radius of base.

Table 3. Initial Screening of Candidate Vehicles for Conversion to CNG Operation

Item	Vehicle Type	Fuel Usage (mi/gal)	Fuel Usage (mi/day)	Savings Per Gallon (\$)	Savings Per Day (\$)	Conversion Kit Cost (\$)	SPB Operating (Days)	SPB Operating (Years)
1.	Light Delivery	25.	75	.50	1.50	~\$2300.	1533.	7.7
2.	Sedan	12.5	75	.50	3.00	~\$2540.	846.	4.2
3.	Bus	5.	200	.50	20.00	~\$6620.	331.	1.5

Note: It is assumed that (a) fuel savings is \$0.50 per equivalent gallon, and (b) an operating year consists of 200 actual operating days. The simple payback (SPB) shown does not include payment for the additional capital cost required if a refueling station must be constructed.

Table 4. Estimated Cost of Installed CNG Conversion Kits

<u>Item</u>	<u>Description</u>	<u>Estimated Cost (\$)</u>
1.	CNG Conversion kit (exclusive of CNG Storage Tanks)	~900.
2.	Installation Fee for Kit and CNG Storage Tanks	~900.
3.	2 to 4 gallons (equivalent) CNG Storage Tanks	~500.
	Total	\$2300.

Note: These are typical costs arrived at after discussions with several vendors and should be used, only, for preliminary estimating. The major variable in the installation of CNG conversion kits is the cost of increased tankage. For capacities greater than 4.0 gallons, the cost of each additional gallon is approximately \$120.00. For example, a 10 gallon tank would cost \$1220. (\$500.00 + 6 x \$120.00), for a total conversion kit cost of \$3020.00.

Table 5. Dimensional and Capacity Data For CNG Fuel Cylinders  
For Natural Gas Vehicles\*

Tank Model	External Diameter (in.)	External Length (in.)	Internal Volume (ft. <sup>3</sup> )	Weight (lb.)	Capacity (SCF) (Equivalent Gallons)	Approximate Cost (\$)	
						1-49 units	200 + units
10FR34	11.5	34.	1.43	95.	367.	421.	327.
10FR40	11.5	40.	1.73	114.	445.	421.	327.
10FR44	11.5	44.	1.93	125.	496.	442.	341.
10FR50	11.5	50.	2.23	141.	573.	465.	360.
13FR40	14.	40.	2.78	176.	714.	587.	453.
13FR44	14.	44.	3.08	192.	792.	610.	470.
13FR54	14.	54.	3.85	232.	989.	727.	561.
15FR32	16.3	32.	2.80	200.	720.	644.	497.
15FR54	16.3	54.	5.23	347.	1344.	1007.	777.

\* Data Published by Pressed Steel Tank Co., Inc., Milwaukee, WI, January, 1989.  
Lightweight Fiber-Reinforced Composite Steel Cylinders.

Tank Description

FOR USE IN PASSENGER CARS, BUSES, LIGHT TRUCKS, VANS, CITY FLEET VEHICLES AND LIFT TRUCKS. Fiber-reinforced NGV cylinders are manufactured under CTC No. 1880 Special Permit, D.O.T. E8965 exemption and meet the proposed NFPA Standard and CGA Standard for natural gas vehicles.

Table 6. Estimated Costs For Elements of CNG  
Refueling Station For 50-Vehicle Fleet

Basic Assumption: 50-Vehicle fleet consuming an average of seven gallons of fuel per day per vehicle for a total of 350 gallons/day.

<u>Item</u>	<u>Description</u>	<u>Estimated Cost</u>
1.	Compressor plus Controls & Accessories, Installed. NG Suction pressure - 5 psig. Delivery-50 CFM at 3600 psig, 27.3 gallons/hour, refueling 3.9 vehicles/hour. Specific Energy - 0.70 kW-hr/100 CF.	\$60.K
2.	Cascade Storage Modules, Installed. 20 Tanks, 9000 CF/Module. Useful storage before re-charge - 3000 CF (27.3 gallons).	\$13.K/Module
3.	Slow-Fill Vehicle Re-Fueling Field. Nine 4-Vehicle Refueling Posts. Total - 36 Refueling Installations.	\$25.K (-\$700./installation)
4.	Fast-Fill Refueling Station, 2 hoses. Automatic Dispenser, Installed. Manual Dispensers, Installed.	\$30-40.K \$8.K
5.	Compressor plus Controls, Accessories, Installed. NG Suction pressure $\geq$ 50 psig Delivery $\geq$ 100 CFM at 3600 psig, 55 gallons/hour, refueling $\geq$ 6.8 vehicles/hour. Specific Energy $\leq$ 0.40 kW-hr/100 CF.	\$125.K

Note: For compressors of comparable design (i.e., similar mechanical design and operating with similar gas conditions), the installed cost of the compressor varies approximately as 1/2 power of the capacity. That is,

$$\text{Cost for Unit 2}^* = (\text{Cost Unit 1}) \times \left( \frac{\text{CFM Unit 2}}{\text{CFM Unit 1}} \right)^{0.5}$$

\* See Plant Design and Economics For Chemical Engineers; Peters, Max S., and Klaus D. Timmerhaus, McGraw Hill, 1980, p. 559.

Table 7. Estimated Costs of Refueling Station Designs For 50-Vehicle Fleet.

Basis: 50-Vehicle fleet consuming an average of seven gallons of fuel per day per vehicle for a total of 350 gallons/day.

<u>Case</u>	<u>Description</u>	<u>Components</u>	<u>Cost (K\$)</u>	<u>Comments</u>
1.	Slow-Fill, Only	50 CFM Compressor	60.	Lack of fast-fill capability. Usually not acceptable
		Station Installed Slow-Fill Field (No Dispenser Req'd)	<u>25.</u> 85.	
2.	Fast-Fill, Only No Storage	50 CFM Compressor	60.	Vehicles must wait too long to re-fill.
		Dispenser.	8. — 68.	
3.	Fast-Fill, Only, With Storage to fill 23 vehicles	50 CFM Compressor.	60.	Expensive, bulky compressor station. May be operationally adequate.
		6 Cascade Modules.	78.	
		Dispenser	8. — 146.	
4.	Fast-Fill/ Slow-Fill With Storage to fill 4 vehicles	50 CFM Compressor.	60.	Good.
		1 Cascade.	13.	
		Slow-Fill Field.	25.	
		Dispenser.	8. — 106.	
5.	Fast-Fill/ Slow-Fill (Dual Compressor) With Storage to fill 4 vehicles	2-25 CFM Compressors.	85.	Better. Provides back-up compressor.
		1 Cascade.	13.	
		Slow-Fill Field.	25.	
		Dispenser.	8. — 131.	
6.	Fast-Fill, Only No Storage	100 CFM Compressor.	125.	May be satisfactory. Gas Supply must be 50 psig. Fast fill refueling rate marginal. (7.8 vehicles/hour)
		(Require $\geq$ 50 psig Natural Gas Supply) Dispenser.	8. — 133.	

Table 8. CNG Fuel Capacity of Tanks With an Internal Volume of 1.0 Ft<sup>3</sup>

<u>Tank Pressure</u> (psi)	<u>Tank Capacity - SCF/Equivalent CNG gallons</u>		
	<u>20°F</u>	<u>55°F</u>	<u>90°F</u>
3200.	316./2.8	277./2.50	244./2.22
2800.	288./2.62	245./2.34	216./1.97
2400.	247./2.25	211.6/1.92	186./1.69
2000.	206./1.87	177.5/1.61	156./1.42
1600.	158./1.44	138.5/1.26	122./1.11
1200.	113./1.03	99.0/0.09	89.5/0.81
800.	70./0.64	63.6/0.57	57.0/0.52
400.	32.3/0.29	29.5/0.27	27.3/0.25
0.0	0.0	0.0	0.0

**Note:** Values given are approximate ( $\pm 7\%$ ) because of the variability of the composition of natural gas. That variability influences both the heating value (Btu/SCF) and the compressibility factor of the natural gas.

**Example:** Filling a tank having an internal volume of 3.0 ft<sup>3</sup> from an initial CNG pressure of 1200 psi and 55°F to a final pressure of 2800 psi requires 438 SCF (or 3.99 equivalent gallons). (3.0 (245.-99.) = 438 SCF)



Table 9. Equipment and Tools Required for Installation/Maintenance of CNG Vehicle Conversion Kits

Support Equipment

Engine Analyzer  
 Emissions Analyzes  
 Vehicle Dynamometer  
 Floor Jack (or Lift)  
 Compressed Air  
 Tachometer  
 Carburetor kit (pressure/vacuums gauges)  
 Gas Tool Kit (flow meter, regulator adjustment tool)  
 Fork-lift (for cylinders at refueling station)  
 Compressor Piston Wrench

Basic Tool Requirements

3/8 inch Drive Socket set: 5/15 inch - 3/4 inch  
 1/2 inch Drive Socket set: 1/2 inch - 1 inch  
 5/16 inch through 1 inch Combination Wrench Set  
 Straight Bladed Screwdrivers  
 No. 1 and No. 2 Phillips Screwdrivers  
 Needle Noses Pliers  
 Adjustable or Waver Pump Pliers  
 Wire Stripper and Crimping Pliers  
 1/16 inch - 1/8 inch - 5/16 inch - 7/16 inch -  
 1/2 inch Drill Bits  
 2 Drill Motors: 1/4 inch Chuck and 1/2 inch  
 Chuck

Hacksaw  
 Jackstands  
 Timing Light  
 Distributor Wrenches  
 Vice Grips  
 Hammer  
 Center Punch  
 Drop Light  
 Scissors  
 Aligning Drifts  
 7/16 inch Tubing Wrench  
 12 Volts Test Light

**Appendix A**

**SUMMARY OF TEST RESULTS AND LESSONS LEARNED  
FOR CNG-FUELED VEHICLES AT PWC, SAN DIEGO**

**SUMMARY OF TEST RESULTS FOR  
CNG-FUELED VEHICLES AT PWC, SAN DIEGO\***

**1.0 BACKGROUND.** The Navy operates and maintains over 26,000 administrative motor vehicles at shore facilities worldwide under the Civil Engineer Support Equipment (CESE) program. (Administrative vehicles are defined as sedans, buses, station wagons, and pickup trucks up to 8500 lb. gross vehicles weight). DOD mobility energy goals were established by OPNAVINST 4100.5B to reduce liquid petroleum fuel consumption for these vehicles and, when practical, to substitute more abundant or renewable fuels. As the CESE program is centrally managed by the Naval Facilities Engineering Command (NAVFAC), NAVFAC was tasked with implementing programs to expand the use of alternative fuels for vehicles to meet DOD goals.

**2.0 MISSION/CONCEPT OF OPERATION.** The objective of this project was to demonstrate the feasibility of using compressed natural gas (CNG) as an alternative fuel to meet the needs of the Navy's administrative vehicle fleet. Testing at the PWC San Diego Transportation Center was conducted to identify performance, design, logistical support, and economic requirements to guide the appropriate use and implementation of CNG vehicles and refueling equipment. The projected benefits of this project included:

- (1) A reduction in the cost of fuel for the vehicles.
- (2) Reduced maintenance costs due to lengthened preventive maintenance intervals,
- (3) Extended range of vehicles because of the capability to use both natural gas and gasoline.
- (4) Reduced pollution emissions from CNG-fueled vehicles,

**3.0 CNG TEST FLEET.** A one-half ton pick-up, a bus, and a panel-van were converted to run on CNG in February, 1986 at PWC, San Diego. A small CNG refueling station was installed at the same time. Two additional vehicles (3/4-ton pick-ups) were converted to run on CNG to test other conversion kits in May, 1987. Testing continued through November, 1989.

**4.0 CNG OPERATIONAL SUITABILITY.** The sections below discuss the results of the test program for determining the suitability of using CNG as a vehicle fuel for Navy vehicles. Table A-1 provides a summary of the vehicles converted to CNG operation, the CNG conversion kits used, miles driven, fuel used, and the estimated annual savings that each vehicle would generate if it were operated under reasonably favorable circumstances (see paragraph 4.4).

\* Some of the results reported here were previously discussed in Reference A-1. Other publications of this project are identified as References A-2 to A-4.

**4.1 Vehicle Performance.** The five vehicles were driven a total of 105,462 miles, averaging 6816 miles per vehicle per year (see Table A-1). A total of 13,490 gallons of fuel (gasoline plus equivalent CNG) were used, 54 percent of which was CNG.

Although CNG has a higher octane rating than gasoline, the reduced density of the fuel vapor being drawn into the engine contributes to a loss in engine power. Power losses for the Navy CNG-fueled vehicles ranged from 5 to 21 percent. (Manufacturers of kits, generally, predict power losses ranging from 5 to 15 percent). Performance improved, somewhat, as adjustments were made to the vehicles as the program progressed.

Three of the five vehicles were operated at low speeds on the Naval Station so that loss in horsepower was not a problem. However, the bus experienced severe problems when the driver took passengers to NAS, North Island. For this he had to switch to gasoline to go over the Coronado Bridge because of the bridge's steep incline. This problem was later partially corrected (see below). The 3/4-ton pickup with the dual-fuel Tartarini conversion kit never did operate satisfactorily. As a result, this vehicle was eventually converted to dedicated CNG-operation using an Impco kit, and now runs satisfactorily. (It should not be concluded from this single result that the Tartarini is not a good kit. Rather, learning how to maintain three different types of kits, simultaneously, probably placed excessive demands on the vehicle mechanics). Although the 3/4-ton pickup with the dual-fuel Impco kit is also running satisfactorily, it will be converted to dedicated CNG operation in January, 1991, to improve its performance.

**4.2 Driver Acceptance.** Training of the drivers of the CNG vehicles is essential to a smooth-running operation. At PWC, San Diego, however, it was difficult to properly train all the drivers that operate the CNG vehicles as each vehicle was normally driven by several people. If drivers were not given adequate training or if the vehicles did not operate satisfactorily, the drivers tended to run the vehicles on gasoline.

**4.3 Dual Fuel Flexibility.** Vehicles with a dual-fuel capability (i.e. having both CNG and gasoline fuel tanks) have the advantage of an extended operating range. A problem with dual-fueled vehicles, however, is that drivers sometimes choose to use gasoline because of the greater horsepower available and/or because they are familiar with gasoline. Of course, this reduces the savings that can result from using CNG. Drivers do not have that choice with dedicated CNG vehicles.

To track actual driver driving habits, hour-meters were installed in the two 3/4-ton pickups to record the times for gasoline and CNG operation. One pick-up was driven on CNG 38 percent of the time; the other 80 percent of the time. In the latter case the driver had no choice but to use CNG following the pickup's conversion to dedicated CNG operation. Using the total quantity of CNG delivered by the gas company, the fuel usage rate and odometer readings of the individual vehicles, and assuming that the three remaining vehicles operated on CNG an equal percentage of the time, it was estimated that the three latter vehicles operated on CNG 58 percent of the time. Although drivers were continuously encouraged to use CNG fuel, the overall average usage rate of CNG was only

54 percent. This is considerably less than a reasonable target (>80 percent) for a CNG fleet.

**4.4 Fuel Costs and Savings.** Costs for fuel at the San Diego Naval Station in 1988 were \$.73 per gallon for gasoline and \$.90 per therm of natural gas (or \$.99/equivalent gallon of gasoline). The natural gas costs included a \$.30 per therm surcharge that PWC assessed base customers for the maintenance of distribution lines and meters. Therefore the surcharge became a significant factor in determining the cost-effectiveness of using CNG as an alternate fuel in San Diego. However, because of deregulation of the natural gas industry natural gas prices vary widely throughout the country and CNG can be purchased at significantly lower prices elsewhere. For example, if it could be assumed that the vehicles were operated completely on CNG and that there was a net savings of \$.50/gallon for using CNG rather than gasoline, the potential savings per year per vehicle would have ranged from \$44.50 for the 1/2-ton pickup to \$865.00 for the bus (see Table A-1). The low savings for the pick-up were due to the low annual mileage (2050 miles per year), the low fraction of mileage on CNG (only 54 percent), and the low rate of fuel usage (23 miles per gallon). Based on economic return, the pickup would not be a good candidate for conversion to CNG operation. High annual mileage and high rate of fuel usage resulted in much greater savings for the bus.

**4.5 Maintenance.** The maintenance requirements of CNG-fueled vehicles are similar to those for gasoline-fueled vehicles. However, to ensure a smooth transition in fleet operations it is important that the mechanics for the CNG vehicles receive adequate supplementary training. In the present program a substantial period of time (2 years) was required before some of the operational "bugs" that arose during implementation of the CNG vehicles were resolved. This delay was attributed to insufficient involvement of the vendors for providing back-up assistance, inadequate initial training of the mechanics, and the time required for the mechanics to come up on the learning curve. The decision to install three different types of CNG conversion kits probably placed an excessive burden on the mechanics. Because of these difficulties the mechanics are to be commended for their persistence and resourcefulness in taking on "something new" and making it work.

Two examples illustrate the problems encountered by the San Diego fleet:

a. The bus had a persistent lack of power and an overheating problem following conversion to CNG operation. This was evidenced, in particular, by the difficulty in driving the bus over the San Diego - North Island bridge. After several tries the problems were, largely, resolved by: (1) replacing the CNG inlet valve to the air/fuel mixer with a larger one (the original one was incorrectly sized) and, (2) by installing an electric fuel pump for the gasoline. Much of the overheating, apparently, was due to an excessively lean CNG fuel/air mixture which was corrected by the larger valve. The operator is now more satisfied with the operation of the bus.

b. There was a persistent lack of power in the 3/4 ton pick-up. (Tartarini CNG kit). The conversion kit was eventually replaced by one from another manufacturer and the vehicle was dedicated to single-fuel CNG operation. The vehicle now operates satisfactorily.

It is believed by some that CNG produces a hotter flame than gasoline and that this can lead to overheating of the engine. However, the combustion temperature of CNG, actually, is slightly lower than that for gasoline. When overheating is observed, it is more likely an indication that either the fuel mixture is too lean or that the engine has not been properly timed for CNG operation. Some vehicles (vans, for instance) have less space in the engine compartment leading to more difficult installations and less air circulation. But this is a smaller part of the problem. The overheating of the bus, for example, was eliminated once the cooling system was checked and the fuel mixture was properly adjusted after installation of a new gas valve.

The mechanical problems described here for start-up of this test fleet are not unique to the Navy. Other operators of CNG fleets have encountered similar (sometimes more severe) mechanical problems, apparently because proper maintenance procedures were not established at the beginning of operations.

**4.5.1 Preventive Maintenance Intervals.** CNG conversion kit manufacturers state that oil change intervals can be substantially lengthened because CNG is a cleaner burning fuel than gasoline and that the oil does not get dirty as quickly. Although this has been shown to be the case in some fleet operations, there was no clear indication in the Navy tests of any increase in oil life due to the use of CNG.

**4.5.2 CNG Cylinder Inspection.** Both composite reinforced aluminum CNG cylinders and pressed steel CNG cylinders were used in the test vehicles. The refueling station also has a 16-steel-bottle cascade. Current Department of Transportation (DOT) regulations require that all high-pressure cylinders be hydrostatically tested every 2 years (although efforts are underway to increase this time interval to three years). This is in accord with NAVFAC directives which state that all tanks operating with pressures above 3000 psi must be physically inspected and hydrostatically tested every 2 years. It costs the PWC Transportation Department \$78 per bottle to have the bottles inspected and hydrostatically tested so that the cost to remove and replace the 27 bottles used for the CNG test fleet (vehicles plus refueling station) every two years is \$2100 (about \$200.00/vehicle-year).

**4.6 ATMOSPHERIC EMISSIONS.** Pollutant emissions from CNG-fueled vehicles are less than those from gasoline-fueled vehicles. Carbon monoxide and reactive (non-methane) hydrocarbons are significantly less than for gasoline-fueled vehicles, although total hydrocarbon emissions (including methane), are often greater for CNG-fueled vehicles. Classification of hydrocarbon emissions is helpful in California where current emission limits apply to "reactive hydrocarbons". In other areas of the country, however, "total hydrocarbon" emissions are often used for setting emission standards. Nitrogen oxide emissions from CNG - fueled vehicles are slightly less than those for gasoline.

Emission measurements for the Navy test vehicles during this program confirmed the emission levels described above for hydrocarbons and for carbon monoxide. Measurements were not made for nitrogen oxides.

**4.7 CNG Refueling Station.** The location of the CNG refueling station on a Navy base is an important consideration. The station should be at a location convenient for the drivers, and the site should be paved or graveled for access in bad weather. Easy access to natural gas supply lines and to electrical transformer pads is also necessary to keep installation costs down. The refueling station must be constructed to conform to the National Fire Protection Association (NFPA) Standard 52, which requires that all electrical equipment within 10 feet of the compressors be explosion-proof. To avoid the high cost of explosion-proof electrical enclosures, however, it is recommended that they be located further than 10 feet from the compressors. Access to emergency shutoffs for both the CNG and electricity must be available at all times. The compressors should be in a fenced and locked area and each CNG vehicle should be equipped with a key.

The CNG refueling station in San Diego was trailer-mounted. The compressors produced 4 cubic feet per minute so that it took approximately 12 hours to fully charge the refueling cascade. The compressors had a combined capacity of 4800 cubic feet/day (for a 20-hr. run-time) representing a daily maximum capacity of 44 equivalent gallons (an equivalent gallon here is assumed to be 110 SCF of gas). This represents 10,900 equivalent gallons in a 250 day work-year. Considering that each compressor operated independently, at times, and that they were not heavy-duty machines, the compressors were considered only adequate for delivering the required 2100 equivalent gallons of CNG per year. (Actual gas delivered, as measured by the San Diego Gas Company meter, was 7260 equivalent gallons during the three and one-half year program).

Initial problems with the refueling station were caused by its location in a marine environment. The electrical components in the hazardous duty enclosures failed due to corrosion and faulty wiring. Galvanized pipe, used by the contractor in parts of the original installation also had to be replaced. One compressor was rebuilt and several valves, switches and sensors were replaced. One compressor was available for about sixty percent of the time of the other. These compressors were not heavy-duty machines and, in the opinion of the mechanics, were not well-suited for long-term applications.

**4.5.1 Refueling.** The test vehicles were refueled with CNG using a refueling probe which looks similar to a gasoline nozzle. The driver drove up to the CNG refueling station, turned off the vehicle's engine, removed the dust plug from the vehicle's refueling line, and inserted the refueling probe through the vehicle's grill. Once the tanks in the vehicle were filled the driver removed the probe and released the pressure in the fill line. The dust plug was reinserted. The drivers were asked to record the ambient air temperature and the CNG pressures before and after refueling to determine the quantity of CNG added. The drivers were also asked to estimate the percentage of time that the vehicles were being driven on CNG and gasoline. There turned out to be little correlation, however, between the drivers estimated time-of-use of CNG and gasoline and actual use as calculated from odometer and measured fuel dispenser readings. Therefore to obtain reliable fuel-usage data in the future it is recommended that time-of-use hour-meters be installed in each vehicle.

**5.0 SUMMARY.** The conversion and operation of five vehicles provides useful experience for the operation of CNG-fueled vehicles. However, because of the diversity of the vehicles converted (four different types of vehicles using three different conversion kits), only a limited amount of data could be collected for each type of equipment. Therefore, the experimental results collected were reviewed and compared with those from other CNG-fleet operations in an attempt to arrive at generally useful conclusions.

- The saving of petroleum and the reduction of vehicle energy and maintenance costs does not, automatically, occur when CNG-fuel is substituted for gasoline. Because converted vehicles are usually dual-fuel, saving petroleum requires that the drivers be willing to select CNG fuel when given a choice of using gasoline. Difficulties with vehicle performance and with less than adequate CNG fuel capacities of vehicles can lead to reduced CNG usage so that neither significant petroleum savings nor CNG system pay-back are realized. In the current test program the vehicles used CNG about 54 percent of the time which is significantly less than a reasonable target of at least eighty percent. For those cases where vehicles can be dedicated to CNG operation, improved vehicle performance and economic return can occur. When vehicle performance is satisfactory, when the drivers understand how to operate the vehicles, and when sufficient CNG fuel capacity is provided the drivers will usually be happy to use CNG.

- Minimizing fuel costs was not a test objective. Consequently, there were no savings in fuel costs in the San Diego tests. The cost of CNG (following addition of a PWC service charge) exceeded the cost of an equivalent quantity of gasoline. However, at other bases, where the cost differential may be favorable, savings could occur. The magnitude of the savings must be determined on a case-by-case basis. Pay-off of the capital costs for installation of a CNG fuel system depends upon both the savings realized per gallon and the gallons of fuel used per day by each vehicle. From an economic point-of-view it was shown that the 1/2 ton pickup was a poor choice for conversion whereas the bus could be a good choice.

- No significant reduction in maintenance costs for the Navy's CNG-fueled vehicles relative to those for gasoline operation were noted. However, other CNG fleet operators have reported reduced maintenance costs. Some operational problems persisted well into the test program. These were not unlike those observed in other fleet CNG programs, and were attributed to insufficient technical support of the vendor and to lack of an initial familiarity of the assigned mechanics to CNG vehicles. The mechanics later became proficient with the CNG systems and the eventual acceptable operation of the vehicles is attributed to their persistence, interest and resourcefulness in dealing with a new system.

- A dual-fueled vehicle gives drivers the flexibility of choosing which fuel to use and extends the mileage range of the vehicles. However, if the vehicles do not perform adequately with CNG, the drivers resist using it.

- Reduced air emissions were noted. Our measured pollutant emissions from the CNG-fueled vehicle fleet were similar to those reported by other investigators. Carbon monoxide and reactive hydrocarbon emissions were substantially less than for gasoline, but total hydrocarbon emissions were



greater. Nitrogen oxide emissions were not measured, but other test projects have shown those to be slightly less than for gasoline. However, regardless of the emissions produced, rules now in effect in some parts of the country will require (within five years) that fleet vehicles be fueled with an alternative fuel. CNG is a recommended fuel for meeting this requirement. CNG is also (currently) less expensive than any competing alternative fuel.

**6. CONCLUSIONS.** A number of practical problems were identified which could interfere with the successful implementation and operation of a CNG-fueled vehicle fleet. Assuming that these problems can be obviated by careful planning and execution, the use of CNG to fuel motor vehicles:

- (1) will help to save America's petroleum-based resources to the extent that it is used as a direct substitution for gasoline,
- (2) will reduce environmental emissions,
- (3) will reduce the cost of fuel for vehicles at some locations,
- (4) may help to reduce vehicle maintenance costs,
- (5) will extend the range of the vehicles (but at the expense of vehicle performance and load - carrying capacity) by using both gasoline and CNG,
- (6) can be justified on purely economic grounds at locations where sufficient fuel savings can be identified (depends upon fuel savings per gallon and fuel usage per day).

#### REFERENCES

- A-1 "Operational Test Report For Compressed Natural Gas Vehicles," Karen D. Miller, TM No. M-73-88-02, November 1987.
- A-2 "Test and Evaluation Plan For Compressed Natural Gas Vehicles," Karen D. Miller and Douglas E. Dahle, TM No. M-73-85-08, June 1985.
- A-3 "Usage of Alternatively Fueled Vehicles at Navy Bases," Karen D. Miller, TM No. M-73-86-28, September 1986.
- A-4 "Letter Report on the Use of Alternatively Fueled Vehicles," Michael J. Villegas, 27 September 1988.

Table A-1

## CNG Vehicle Fleet at 32nd Street Naval Station, San Diego

Vehicle	Conversion Date	Manufacturer and Type of Conversion Kit	No. of Miles Run Since Conversion	Hours of Operation CNG Gasoline	Rate of Fuel Usage (mi./gal.)	Total Fuel Usage (equivnt. gals.) CNG Gasoline	Total Fuel Usage (gallons)	Months Since Conversion	Average Miles/year	Potential Fuel Savings/Year (\$)
USN 94-19682 1985 Dodge 3/4 Ton Pickup Truck (6 passenger crew cab) (V-8, 360 in <sup>3</sup> engine)	5/87	Tertarini (dual-fuel)	10,150	352	10	812 203 (estimated from hour meters)	1015	31	3929	196.00
USN 94-19684 1985 Dodge 3/4 Ton Pickup Truck (6 passenger crew cab) (V-8, 360 in <sup>3</sup> engine)	6/88	Impco (dedicated CNG)								
USN 94-19684 1985 Dodge 3/4 Ton Pickup Truck (6 passenger crew cab) (V-8, 360 in <sup>3</sup> engine)	5/87	Impco (dual-fuel)	39,330	587	10	1494 2438 (estimated from hour meters)	3932	31	15,224	761.00
USN 94-20857 1985 Dodge 1/2 ton Pickup Truck (Dodge D-50) (4 cyl, 2 liter engine)	2/86	Dual Fuel (dual-fuel)	7,688	N/A	23	194 140 (CNG = 58% )	334	45	2,050	44.50
USN 91-06197 1980 International 30 Passenger Bus Model 1723 (V-8, 392 in <sup>3</sup> engine)	2/87	Dual Fuel (dual-fuel)	25,964	N/A	4	3764 2727 (CNG = 58% )	6491	45	6923	865.00
USN 94-21271 1985 Dodge Van (D-250 Custom) (6 cyl, 225 in <sup>3</sup> engine)	2/86	Dual Fuel (dual-fuel)	22,333	N/A	13	996 722 (CNG = 58 %)	1718	45	5955	229.00
Totals			105,462			7260 6230	13,490		34,081	

**Appendix B**

**SAMPLE PURCHASE DESCRIPTION SPECIFICATIONS FOR  
CNG VEHICLE CONVERSION KITS AND REFUELING STATION**

SAMPLE  
DESCRIPTION/SPECIFICATION

INTRODUCTION:

This project consists of providing and installing a compressed natural gas (CNG) fueling station and converting \_\_\_ government-owned vehicles currently using gasoline as a fuel to vehicles that will use either CNG or gasoline. All questions regarding these specifications should be directed to the Base Contracting Office (Tel. No. ).

a. ITEM 0001 - FUELING STATION:

Upon receipt of the contractor's specifications for the fueling station selected for installation, the government will furnish the concrete pad, tie-down points, required electrical power, and "snubbed-up" natural gas feeder line for the installation of the CNG fueling station adjacent to the existing gasoline fueling station located at . The contractor's representative will be available to assist the government in designing the layout for the refueling site.

(1) The compressor must be a (Manufact./Model) Natural Gas Compressor, or equivalent. \_\_\_\_\_ ft<sup>3</sup> of CNG Storage shall be supplied.

(2) Compressor must be water-cooled and capable of servicing the proposed 55-vehicle fleet with the CNG equivalent of \_\_\_ gallons of gasoline per vehicle, per month, using a \_\_\_-day month as standard and must be capable of handling sustained growth to as large as a \_\_\_-vehicle fleet with a \_\_\_-hour supply. \_\_\_\_\_ "slow-fill" stalls shall be provided.

(3) Fueling station will be configured for "fast fill" operations supporting 2-4 vehicles simultaneously, in addition to "slow-fill"

(4) Fueling station storage capacity for CNG must provide for a \_\_\_-hour supply of CNG for the \_\_\_ vehicle fleet at the consumption rates identified below. This storage capacity must be capable of easy economical expansion to support a \_\_\_-vehicle CNG fleet with a \_\_\_-hour supply of CNG.

(5) Delivery system must incorporate a methanol injector for drying the compressed gas entering and leaving the system.

(6) The fuel delivery system for refueling the vehicles will employ the Hansen(R)-type grill fill quick disconnect.

(7) All components are required to have a minimum operating pressure of 3000 psi.

(8) Reserved.

(9) All work on Fueling Station must be complete prior to the delivery of the first CNG-converted vehicle.

(10) Contractor to Notify Base Contracting Office: Contractor will notify the Base Contracting Office, (Tel. No.     ), at least 14 days prior to delivery.

(11) Existing Utilities - \_\_\_\_\_ Gas Company: Line pressure at \_\_\_\_\_ Naval Station is nominally \_\_\_\_\_ pounds per square inch. All utility outages will be coordinated between, and approved by, Civil Engineering and using agency, one week prior to utility disruption.

(12) Technical Definitions:

(a) COMPRESSED NATURAL GAS (CNG): A combustible compressed gas mixture of Methane ( $CH_4$ ) and higher hydrocarbons to be employed as an alternate source of fuel for internal combustion powered motor vehicles.

(b) DUAL CURVE IGNITION SYSTEM: A mechanism capable of automatically compensating for the respective ignition timing advance or retardation requirements of the vehicle, based upon the fuel system selected by the vehicle operator.

(c) FAST FILL FUELING: A system by which a vehicle may be refueled in two to five minutes.

(d) FUELING STATION: All components necessary for equipping the alternate compressed or liquified gas refueling station, of sufficient capacity to meet the refueling standards of the vehicles identified by this contract, to include fuel storage, compressors, regulators, meters, dispensers, hoses, valves, and receptacles, and related safety, environmental, and fire prevention equipment and/or structures.

(e) REGULATOR: A device which reduces liquified or compressed gas to nearly atmospheric pressure for the purpose of being metered through an internal combustion engine's carburetor or fuel injection system.

(f) TWIN FUEL CAPABILITY: The capability of easily switching back and forth, at the option of the vehicle operator, between the alternate compressed or liquified gas fuel source and the original fuel source, whether the vehicle is or is not in motion.

(g) SCHRAEDER VALVE: A stem-type valve used as test port on the first stage regulator to determine outlet pressure.

(h) LOW PRESSURE RELIEF VALVE: A safety device between first and second stage regulator to protect the low pressure side of the systems.

(13) List of Applicable Publications:

<u>PUBLICATION</u>	<u>TITLE</u>	<u>DATE</u>	<u>MANDATORY/ ADVISORY</u>
NFPA-52	National Fire Protection Association (NFPA) <u>Compressed Natural Gas (CNG)</u> <u>Vehicular Fuel Systems 1984</u>	05 Jul 84	Mandatory
PART 49	Code of Federal Regulations (Approved DOT Exemptions Included)		Mandatory

b. ITEM 0002 - ALTERNATE COMPRESSED GAS FUELING SYSTEM ON 55 GASOLINE VEHICLES

(1) The government will furnish one covered work bay or equivalent work space either in, or immediately adjacent to, Building \_\_\_\_\_, Vehicle Maintenance Facility, \_\_\_\_\_, for the purpose of performing the work scheduled under Item 0002.

(2) Minimum System Components: The following equipment is the minimum configuration for each vehicle:

**OPERATING PRESSURE:** All components are required to support a minimum operating pressure of 3000 psi

**FUEL GAUGE:** NEI fuel gauge — 3000 psi system

**SWITCH:** Rotary switch for switching between fuel system

**FUEL LINES:** Stainless '304' steel fuel lines; double ferrule type fittings ('Swedge-Lock', or equivalent)

Carlisle Dry Gas Tubing (USCG approved) should be employed wherever applicable

Fuel delivery lines will be anchored in spans of no more than 24 inches to keep lines from rubbing

**VALVES:** Schrader valve, or equivalent  
Low-pressure relief valve

**FILL MECHANISM:** Hanson quick-disconnect "grill-fill" or equivalent

**EMERGENCY SHUTOFF:** Emergency manual shutoff valve: remote emergency shutoff valve is to be located within one step of the driver exiting the vehicle

**INTERLOCK:** Ignition interlock system

**REGULATOR:** Water-heated first-stage regulator

**VARIABLE VENTURI:** If a variable venturi is employed, a vacuum lift system for the carburetor must be incorporated into the system

**DUAL-CURVE IGNITION:** Dual-curve ignition advance modification (for normally aspirated vehicles)

**FUSES:** All instruments will be fuse protected

**FUEL CYLINDERS:** CNG fuel cylinders must be new (not unused recently hydrostatically tested). These cylinders will be made of any material approved by the Dept of Transportation and comply with all applicable federal, state, local and military standards for valves and venting.

**CERTIFICATION:** Fuel cylinders must be certified within three months of installation

**WIRING:** Wiring must be both oil and gas resistant

**SEALANT:** Sealant (silicon, Teflon, or equivalent) around mixer, will in no way affect oxygen-sensor readings

\* **EXISTING WARRANTIES:** The contractor must warrant that the installation of their components will, in no way, alter, modify, or render invalid, the full force and effect of the modified vehicle's original manufacturer's warranty

**POLLUTION CONTROL SYSTEMS:** None of the contractor's installed components may displace the vehicle air breather or degrade the modified vehicle's pollution control system, as installed by the manufacturer

**COMMON COMPONENTS:** Due to the wide variety of manufacturers represented in subject fleet, it is in the interest of the Government to insure that the design of the CNG delivery system employ common parts, irrespective of application.

**COMPONENT EXCHANGE:** The majority of the components of individual CNG delivery systems should be capable of being easily transferred from one vehicle in the fleet to another

APPEARANCE AND  
STRUCTURAL  
INTEGRITY:

The CNG delivery system, when installed on the vehicle, will not alter the physical appearance and will in no way diminish the structural integrity of the vehicle

FUEL SWITCHING:

The contractor-installed CNG delivery system must employ a switching mechanism to allow the vehicle operator to easily switch between fuel source, while the vehicle is in motion

TECHNICAL  
DESCRIPTIONS:

The contractor must supply a technical description of their product, which describes how it will satisfy these specifications

GENERAL MOTORS  
VEHICLES:

General Motors vehicles will require a "computer" modification to correct oxygen-sensor readings to preclude "CHECK ENGINE" indications

(3) Minimum Vehicle Fuel System Safety Standards:

(a) Flow of compressed gas shall automatically shut off when vehicle engine is not running.

(b) Vehicle engine shall not be capable of starting while vehicle is being refueled.

(c) Relief devices (pressure and temperature). There must be relief devices in the system to relieve overpressure due to thermal expansion.

(d) Both ends of vehicle compressed gas storage vessels shall be sealed and externally vented outboard from the storage compartment.

(e) Compressed gas piping shall not be allowed inside the driver's compartment.

(f) Contractor-installed conversion equipment shall include all applicable safety devices as required by federal law, rules, and regulations.

(g) All pressure and electrical components shall be employed for their designed function.



**(4) Performance Specifications - (Gas-Powered Vehicles):**

**VEHICLE  
PERFORMANCE  
REQUIREMENTS:**

The contractor will warrant vehicle performance using CNG to conform to a standard of at least 90% of the performance of normal gasoline vehicle operation specifications. All other factors being equal, preference will be given to the highest performance level consistent with reasonable reliability and maintenance. The contractor will describe those components of the proposed conversion system which will assure this level of performance.

**VERIFICATION  
OF VEHICLE  
PERFORMANCE:**

The Government will perform diagnostic tests utilizing a \_\_\_\_\_ Dynamometer on each vehicle before and after the CNG conversion. The Government will establish records for each vehicle and will retain all test data to determine the feasibility of continued CNG conversions.

**BEFORE  
CONVERSION:**

The Government will test the vehicles immediately before conversion under gasoline power. The Government will conduct the first test at 2500 RPM under full load and throttle, to determine available baseline horsepower. The Government will conduct the second test at 25 MPH (with the dynamometer set on 10 horsepower load and 40 MPH) and will record the observed RPM. This test is designed to realistically represent day-to-day vehicle operation.

**AFTER  
CONVERSION:**

The Government will repeat these tests after conversion using both gasoline and CNG power. The Government reserves the right to perform any additional tests it deems necessary to ensure safe CNG conversions which do not adversely affect vehicle or engine performance, reliability, warrantability, and durability.

**GOVERNMENT-  
FURNISHED  
FACILITIES:**

The Government will also provide a work area inside Vehicle Maintenance (Bldg \_\_\_\_\_) and furnish normal hand tools to accomplish conversions. Work space will be restricted to one maintenance stall, due to very limited space.

**SPECIAL TOOLS:**

The contractor will provide all special tools required for the vehicle conversions (cutters, leak detectors, etc.).

**FUEL-SWITCHING  
SYSTEMS:**

The fuel-switching system must be capable of alternating from one fuel system to the other while the vehicle is being operated with no more than a 10% loss of performance while operating under CNG.

Table B-1. Vehicle Description For Conversion to CNG Operation.

Item	Vehicle Type	Reg. No.	Make	Size	No. Cyl.	Engine Description		CNG Storage	
						Carb/FI.	Single/Dual Fuel	(Equiv. Gallon)	Where Mutd.

c. ITEM 0003 - MAINTENANCE OF COMPONENTS FOR ITEMS 0001 AND 0002

The contractor will provide maintenance for all components of Items 0001 and 0002 for a period of one year from the date of acceptance. This includes maintenance over and above the capability of the contractor trained government personnel.

d. Minimum Quality Standards for Items 0001 and 0002:

(1) Safety Standards: All contractor-installed fuel storage tanks, whether stationary or located on the vehicles, shall comply with all applicable safety standards established by the Department of Transportation for the applicable class of flammable and explosive compressed or liquified gases identified in Exhibit C.

(2) Fuel Storage Standards: The Fueling Station and vehicle modifications must comply with all applicable federal, state, and local fuel storage standards and regulations regarding compressed or liquified natural gas.

(3) Horsepower Standards: The contractor-installed alternate fuel system will maintain respective vehicle horsepower specifications to a level of performance not less than 90% of the original equipment manufacturer's specifications—as measured at the wheels—while operating under the contractor-installed alternate fuel system. Baseline horsepower ratings of the vehicles to be modified will be evaluated via dynamometer testing or acceptable equivalent—both before and after the vehicle modifications—unless the contractor stipulates the nominal baseline horsepower and torque ratings identified in the original equipment manufacturer's specifications.

e. MANUALS:

(1) Two copies of all parts books, operator's manuals and service manuals shall be provided for each unit. These shall include, at a minimum, all appropriate manuals for each component of the conversion package.

(2) Additionally, two sets of complete wiring and piping schematics shall be supplied with each unit. All schematics shall be clear and legible.

(3) The manuals and schematics supplied shall provide complete and comprehensive information on components supplied to conform to this specification.

(5) The books and manuals shall be delivered PRIOR TO THE DELIVERY OF THE LAST UNIT. Delivery shall not be considered complete until the manuals are received.

f. TRAINING:

The contractor shall provide training in the operation and maintenance of Items 0001 and 0002 at no additional cost. This training shall be coordinated with Mr Clark, Section Chief, and shall be provided to the satisfaction of the Chief of Transportation. The contractor shall allow video taping of the training sessions and any tapes shall remain the sole property of the Maintenance Section of the Transportation Squadron.

STATEMENT OF WORK

CONVERSION OF VEHICLES TO CNG OPERATION

---

(City)

(State)

## TABLE OF CONTENTS

1	Purpose and Scope
1.1	Purpose
1.2	Scope
2	General Requirements
2.1	Key Personnel
2.2	Engineering
2.3	National Fire Protection Association Standards
2.4	Installation Sites
3	Requirements-
3.1	Vehicle Inventory
3.2	CNG Conversion Kit Components
3.2.1	Fuel Cylinders
3.2.2	Valve Guards
3.2.3	Venting System
3.2.4	Tubing
3.2.5	Tube Fittings
3.2.6	Main Shut Off Valve
3.2.7	Fuel Selection Control
3.2.8	Fuel Gauge
3.2.9	Pressure Gauge
3.2.10	Meters
3.2.11	Fuel Selection Lockout Solenoid
3.2.12	Refueling Connector
3.2.13	Check Valve
3.2.14	Pressure Regulator Assembly
3.2.15	Carburator Adaptor
3.2.16	Natural Gas Mixer
3.2.17	Spark Advance Control
3.2.18	Installation Hardware
3.2.19	Electrical Installation Components
3.2.20	Mounting Brackets
3.2.21	Labels
3.3	Installation Instructions
3.3.1	Component Identification
3.3.2	Component Location and Mounting
3.3.3	Tubing Installation
3.3.4	Wiring Installation
3.4	Spare Parts
3.5	Installation
3.6	Training
3.7	Warranty
3.8	System Performance
3.8.1	Horsepower
3.8.2	Emissions
3.8.3	Cold Temperature Test
3.8.4	Suspension System
3.8.5	Drivability

- 4 Quality Assurance Provisions
- 4.1 Responsibility for Inspection
- 4.1.1 Inspection of Components, Parts and Materials
- 4.2 Inspection System Requirements
- 4.3 Inspection
- 4.3.1 Quality Assurance Sampling
- 4.3.2 Inspection Procedure
- 4.4 Testing
- 4.4.1 Test Procedures

TABLES

- 1 Vehicle Inventory
- 2 Quality Assurance Sampling Plan

1 PURPOSE AND SCOPE

1.1 Purpose. The purpose of this Statement of Work (SOW) is to define the requirements for providing and installing compressed natural gas (CNG) conversion kits on United States Postal Service (USPS) vehicles.

1.2 Scope. The scope of this contract effort covers the providing of CNG conversion kits for the USPS vehicles identified in Table 1 and their installation. This effort includes providing and installing all the components necessary to insure the proper performance of the vehicle and the safety of USPS employees and the general public. This includes all the engineering work necessary for conversion kit design, installation, test and acceptance. This effort also includes performing all the necessary performance checks and minor adjustments prior to conversion and upon completion of the installations. A requirement exists for providing system documentation as well as training covering system installation, operation and maintenance. Finally, a requirement to provide spare parts and labor to support the system for one year must be met.

2 GENERAL REQUIREMENTS

2.1 Key Personnel. The contractor shall assign a single individual to act as project manager for this effort. This individual shall be responsible for coordinating all of the contractor's efforts and for directing all of the contractor's personnel and any sub-contract personnel when working at the designated installation site. The project manager need not be located at this site nor be assigned to the program on a full time basis, but he shall be responsible and answerable for the contractor's efforts and shall be considered to be the contractor's management and technical representative.

2.2 Engineering. The contractor shall be responsible for accomplishing all of the engineering work required to design the CNG conversion kits and to install them into their respective vehicles. The contractor shall obtain all the necessary permits required and shall comply with all the applicable Federal, State, County, and City codes, rules, and regulations covering the conversions of gasoline fueled vehicles to dual fuel operation (gasoline and CNG). The modified vehicles shall meet all the applicable Federal Motor Vehicle Safety Standards and Regulations to the extent that they meet those standards prior to conversion.

2.3 National Fire Protection Association, Inc. Standards. The contractor's design, equipment, and installation shall comply with the Standard for Compressed Natural Gas (CNG) Vehicular Fuel Systems, NFPA 52, except where modified by this SOW.

2.4 Installation Site. The contractor shall install the CNG conversion kits and otherwise comply with the requirements of this SOW at the USPS Vehicle Maintenance Facility (VMF) located at:

---

(Street Address)

---

(City)

(State)

(Zip Code)



his facility is under the direction of:

---

(Name)

(Title)

---

(Commercial Phone No.)

(FTS Phone No.)

The contractor will be allocated a single vehicle bay in which to install the CNG conversion kits. The contractor's work schedule or any other administrative matter concerning safety, work rules, etc. while at this facility shall be coordinated with and approved by the facility director or his designated representative. The contractor is responsible for providing all the necessary tools, materials, and equipment required to comply with his SOW. A maximum of two vehicles per day will be made available to the contractor at the VMF for conversion. Vehicle performance checks and minor adjustments to the vehicle prior to and after conversion, in addition to leak testing at maximum working pressure prior to inspection and acceptance shall be the responsibility of the contractor.

#### REQUIREMENTS

.1 Vehicle Inventory. The vehicles covered by the requirements of this contract are described in Table 1.

.2 CNG Conversion Kits Components. The CNG kits that are supplied for installation in accordance with this Statement of Work will have the following components:

.2.1 Fuel Cylinders. Cylinder capacity and location is specified in Table 1. The fuel cylinders supplied shall be either composite reinforced aluminum (per DOT-E-8725) or fiber wrapped steel (per DOT-E-8965) rated at 3000 psi at 70 degrees F. Steel cylinders shall be treated to prevent oxidation. DOT certification shall be marked on the cylinders in a location that is viewable when the cylinders are installed. The certification date shall be within three months of the delivery date. The cylinders shall be new and inspected to insure that they contain no debris. Each cylinder shall be equipped with a manual shut off valve containing a pressure relief device capable of safely venting the cylinder if the pressure exceeds 3,775 PSI or if the temperature exceeds 212 degrees F. The contractor shall agree to perform at his expense any DOT recertification requirement for the cylinder that is required at less than five (5) years period.

.2.2 Valve Guards. Each of the cylinders provided shall be equipped with a valve guard which will protect the valve from accidental handling impacts and which will offer a degree of protection when installed in the vehicles. The valve guards may be either the standard screw type which requires a threaded collar on the cylinder or they may be of a type which clamps to the neck of the cylinder, or any other appropriate type that provides sufficient protection. A protective metal shield may be used in

lieu of individual guards as long as it may be installed without interfering with the ability to operate the valves. If used, the shield shall be fabricated from steel at least 1/8 inch in thickness, corrosion proofed, and bolted in place.

**3.2.3 Venting System.** The cylinder installation for each vehicle type shall contain a vapor sealing device which will prevent natural gas from entering the vehicle in the event of leakage from the fuel cylinders or manual shut off valves. The vapor sealing device shall be vented to the outside of the vehicle. The use of a transparent material and clamp attachment to the cylinders is required. A protective metal shield shall be provided to protect the material from abrasion or puncture.

**3.2.4 Tubing.** Tubing shall be in accordance with NFPA 52, Section 2-8. All supply lines between the fuel cylinders and the first stage regulator, and between the refueling connector and the cylinders shall be stainless steel.

**3.2.5 Tube Fittings.** Tube fittings shall be in accordance with NFPA 52, Section 2-8. The fittings shall be of the two ferrule compression type such as Swagelok, or equivalent.

**3.2.6 Main Shut Off Valve.** A 1/4 turn manual shut off valve shall be located between the fuel cylinders and the engine compartment components. The shut off valve shall be located outside the vehicle beneath the driver's seat and shall be able to be operated from that position by a driver wearing a seat belt. The valve shall be protected from damage and road debris by a metal shield. A label shall be located on the vehicle to indicate this valve's location with the door opened or closed.

**3.2.7 Fuel Selection Control.** A control switch or device to permit the driver to selectively operate the vehicle on either natural gas or gasoline shall be installed or mounted on the dashboard. This control may be electrically operated from a toggle or rotary switch, or mechanical. If mechanical, the switching operation shall be able to be accomplished with minimal effort. The switch shall be clearly marked to indicate function.

**3.2.8 Fuel Gauge.** A lighted electrically operated fuel gauge which indicates the amount of natural gas in the fuel cylinders shall be provided for dash board mounting in a position so that it can be read from outside the vehicle. This gauge shall be labeled to indicate its function and shall indicate capacity in terms of "Full" and "Empty".

**3.2.9 Pressure Gauge.** A pressure gauge that meets the requirements of NFPA 52, Section 2-6, shall be installed in the engine compartment in the vicinity of the pressure regulator assembly (3.2.14) and shall indicate fuel cylinder pressure when the main shut off valve is open.

**3.2.10 Meters.** Two Stewart Warner, Hobbs Division (or equal) hour meters shall be provided for installation in the dashboard, one above the other in a position enabling them to be read from outside the vehicle. The meters shall be clearly marked to indicate their functions. A mounting bracket may be used. These meters are to be wired through the fuel selection lockoff solenoids (3.2.11) and are to operate when their respective solenoids are activated. The upper meter shall indicate CNG operation.

**3.2.11 Fuel Selection Lockout Solenoid.** Two fuel selection lockout

solenoids are to be provided for connection to both the CNG and gasoline fuel lines. These solenoids are to be controlled by the fuel selection control (3.2.7). These solenoids are to be located in the engine compartment and, in the case of the CNG fuel line, on the low pressure side of the pressure regulator assembly.

**2.12 Refueling Connector.** The refueling connector provided shall be a Hansen Quick Coupler, Series 2-HK, manufactured by the Hansen Manufacturing Company, Cleveland, Ohio. The "stem" portion of the coupling shall be mounted so that refueling can be accomplished through the front grill of the vehicle without requiring the hood to be raised. The refueling connector shall be provided with a dust plug assembly which shall be attached to the vehicle by a metal chain. The refueling connector shall incorporate a means of disabling the starter solenoid circuit whenever the fuel hose is connected.

**2.13 Check Valve.** A check valve shall be provided for installation in line with the refueling connector to prevent the back flow of gas to the fueling connector. The check valve shall be designed to be connected as close as possible to the refueling connector while providing protection from frontal impacts to the vehicle.

**2.14 Pressure Regulator Assembly.** One or more pressure regulators shall be provided to reduce the fuel cylinder supply pressure to a level consistent with the requirements of the natural gas mixer (3.2.16) specified. The pressure level of each stage shall be pre-set to the correct operating pressure. The use of electric heaters or the routing of engine coolant through the assembly is permitted provided that all the components necessary to effect proper installation are provided. The assembly shall contain means to check the first stage outlet pressure through a Schrader type valve test point.

**2.15 Carburetor Adaptor.** The natural gas mixer (3.2.16) shall be designed to mount to the existing carburetor directly or by means of a carburetor adaptor. These components shall be designed so that they attached are supported without causing strain to the existing carburetor. Relative motion between the components is not acceptable.

**2.16 Natural Gas Mixer.** A Natural Gas Mixer shall be provided which will allow the fuel mixture to enter the existing carburetor and allow the engine to operate through its full RPM design range without modification of the existing gasoline carburetor. The Natural Gas Mixer shall also allow the engine to operate properly when fueled on gasoline.

**2.17 Spark Advance Control.** A means of providing the proper ignition timing for both CNG and gasoline is required. This device shall be controlled by the fuel selection control (3.2.7).

**2.18 Installation Hardware.** All hardware used for the installation of components shall be suitable for the intended application and shall be of quality equal to that used on the vehicle. Mounting hardware shall be SAE Grade 5 with suitable corrosion protection. Sheet metal type screws are not acceptable. Threaded connections shall be provided with some means of resisting loosening from vibration such as lock nuts, lock washers, or locktite.

**2.19 Electrical Installation Components.** All electrical components, wire, wire terminals, grommets, etc. shall be capable of withstanding the temperature limits stated in NFPA 52, Section 3.2.2. Wire terminals shall

be of the solderless type. Wire runs shall be neat and free of excessive wire lengths.

**3.2.20 Mounting Brackets.** Mounting brackets used in conjunction with any components shall be free of burrs, sharp edges and corners, be made from corrosion resistant materials or treated to prevent corrosion, and be securely attached to the vehicle with hardware complying with 3.1.18. Vibration which affects the proper operation of the component shall be eliminated.

**3.2.21 Labels.** A Label, as specified by NFPA 52, Section 3-10.1, shall be provided for affixing to the firewall within the engine compartment. Two Labels, as specified by NFPA 52, Section 3-10.2, shall be provided for affixing to the rear of the vehicle as specified by NFPA 52, and to the front bumper, driver's side.

**3.3 Installation Instructions.** This section requires the preparation of conversion kit installation instructions for each vehicle type described in Table 1. These instructions shall be provided in sufficient quantity at the start of the training session required by 3.6. A complete set in an appropriate binder will be provided for the Fleet Manager.

**3.3.1 Component Identification** The installation instructions shall include an identification of each component described in 3.2. Identification shall include the manufacturers name, address, model or part number, and be sufficient for the ordering of that part.

**3.3.2 Component Location and Mounting.** The installation instructions shall include specific information for the location and mounting of the major components described in 3.2. This information shall include but not be limited to the following:

- templates for hole locations,
- installation of mounting brackets,
- identification and quantities of hardware needed,
- fastener torques.

**3.3.3 Tubing Installation.** The installation instructions shall include but not be limited to schematic diagrams of all tubing runs which identify approximate tubing length, tubing diameter, approximate location of bends, proper bend radius, required tube fittings, tubing preparation for fitting make-up, and the components to which each tubing run is connected.

**3.3.4 Wiring Installation.** The installation instructions shall include but not be limited to schematic diagrams of all wiring runs which identify approximate wiring lengths, wiring size, wiring color, routing, required end conditions, identification of terminals the components wires connect to, and the type and location of wire supporting device required.

**3.4 Spare Parts.** A one year supply of conversion kit spare parts shall be provided for each type vehicle identified in Table 1. The quantities of parts shall be based on vehicle usage of 4.5 hours per day for 312 days per year. The component part failure rate used to determine part quantity shall be based on documented fleet use. The components identified in 3.2 shall be categorized as "long lead" items and "standard parts" and all information such as part number and source of supply shall be included.

.5 Installation. Unless otherwise specified by the Contracting Officer, the types and classes of CNG conversion kits ordered shall be installed in accordance with the installation instructions provided in .3. The location of the installation site and the timetable for the installations shall be specified by the Contracting Officer.

.6 Training. The CNG conversion kit supplier shall provide training for Postal Service mechanics and Postal Service vehicle operators at the location identified. The mechanics training shall include but not be limited to general theory of operation, safety, installation, inspection, testing, diagnostics, and repair procedures. The vehicle operators training shall include but not be limited to general theory of operation, safety, and vehicle fueling. An outline of each course material shall be provided in accordance with the delivery schedule specified.

.7 Warranty. All materials and equipment supplied in accordance with this SOW shall be warranted by the contractor for a period of one year or for the period stated by the original component manufacturer, whichever is greater, against all defects in design, materials, and workmanship. This warranty shall include all the labor required to correct defects arising during this time period. Upon notice from the Fleet Manager, the contractor or provider of warranty services shall promptly correct the problem without cost to the Postal Service. A copy of this warranty with the names, addresses and phone numbers of those providing warranty services must be included in the response to this solicitation.

.8 System Performance.

.8.1 Horsepower. The converted vehicles shall be capable of delivering 90% of the demonstrated "gasoline horsepower" when operated in the CNG fuel mode at 55 miles per hour. An acceleration test (0 to 15 MPH, and 0 to 55 MPH) of fully loaded vehicles may be substituted for dynamometer testing.

.8.2 Emissions. The converted vehicles shall be capable of meeting all applicable emission standards while operating in both fuel modes.

.8.3 Cold Temperature Starting. When specified by the Contracting Officer, the converted vehicles shall demonstrate the capability of being started within a maximum of three (3) starting cycles on CNG after twenty-four (24) hour exposure to a temperature of minus 10 degrees Fahrenheit and shall demonstrate the capability of being driven without stalling or hesitation after a maximum warm-up period of three (3) minutes after starting.

.8.4. Suspension System. The installation of CNG conversion kits shall not cause a fully loaded vehicle (operator and payload) to exceed its maximum allowable spring loads. In addition, the fully loaded vehicles, when parked on level ground, shall be level in the transverse plane within 1/2 inches when measured at the extremes of both the front and rear bumpers to the ground.

.8.5. Drivability. The converted vehicles shall exhibit satisfactory operating and handling characteristics when operated with no cargo load and with full cargo load. The braking stability, sway and general road worthiness of the converted vehicles shall be equal to that of the vehicles prior to conversion with an appropriate allowance on braking performance due to the added weight.

#### 4. QUALITY ASSURANCE PROVISIONS

4.1. Responsibility for Inspection. Unless otherwise specified in the contract or purchase order, the contractor is responsible for adjustment, inspection and test of all CNG vehicle conversion kit components and the installations of these same components on USPS vehicles furnished in accordance with this SOW. The contractor may utilize his own or other inspection facilities and services which are acceptable to the USPS. Records of adjustments, inspections, and tests shall be complete and made available to the USPS who reserves the right to perform any of the inspections or tests specified. Copies of check lists, punch lists, etc. which will be utilized by the contractor shall be provided in the response to this solicitation.

4.1.1 Inspection of Components, Parts and Materials. The contractor is responsible for ensuring that all components, parts and materials conform to the requirements and references specified herein.

4.2. Inspection System Requirements. As a minimum, the contractor shall be familiar with Inspection System Requirements, MIL-I-45208.

4.3. Inspection. This section provides Quality Assurance procedures for either the procurement of CNG Conversion kit packages or the conversion of USPS vehicles to CNG-dual fuel operation through the installation of such conversion kits. CNG conversion kit package procurements shall be subject to the Inspection procedures prescribed by 4.3. Vehicle conversions shall be subject to both Inspection procedures and the Testing procedures prescribed by 4.4. All converted vehicles shall be tested.

4.3.1 Quality Assurance Sampling. For each lot a random sample of kits shall be selected in accordance with MIL-STD-105, Inspection Level II, Single Sample Plan for Normal Inspection. A "lot" is defined as either all the kits or all the vehicle conversions covered by this SOW. The Acceptable Quality Level (AQL) for Major Characteristics shall be 6.5. Presence of defects in excess of the AQL shall be cause for the rejection of the lot. Table 2 has been compiled from MIL-STD-105 for your use.

4.3.2 Inspection Procedure. The CNG conversion kits shall be inspected for the following defects.

##### Critical

- 101. Fuel cylinders are not certified as required by 3.2.1.
- 102. Fuel cylinders are not equipped with manual shut off valves as required by 3.2.1.
- 103. Vapor sealing device not in accordance with 3.2.3.
- 104. Main shut off valve not in compliance with 3.2.6.

##### Major

- 201. Fuel cylinders not of material or finish required by 3.2.1.
- 202. Fuel cylinder certification date not in compliance with 3.2.1.
- 203. Valve guards not in compliance with 3.2.2.
- 204. Fuel cylinder capacities or locations not in compliance with requirements in Table 1

- 205. Steel tubing not in compliance with 3.2.4.
- 206. Tube fittings not in compliance with 3.2.5.
- 207. Fuel selection control not in compliance with 3.2.7.
- 208. Fuel gauge not in compliance with 3.2.8.
- 209. Pressure gauge not in compliance with 3.2.9.
- 210. Hour meters not in compliance with 3.2.10.
- 211. Fuel selection lockout solenoids not in compliance with 3.2.11.
- 212. Refueling connector not in compliance with 3.2.12.
- 213. Check valve not in compliance with 3.2.13.
- 214. Pressure regulator assembly not in compliance with 3.2.14.
- 215. Carburator adaptor not in compliance with 3.2.15.
- 216. Natural gas mixer not in compliance with 3.2.16.
- 217. Spark advance not in compliance with 3.2.17.
- 218. Installation hardware not in compliance with 3.2.18.
- 219. Electrical installation components not in compliance with 3.2.19.
- 220. Mounting brackets not in compliance with 3.2.20.
- 221. Labels not in compliance with 3.2.21.
- 222. Installation instructions not in compliance with 3.3.
- 223. Spare parts list not in compliance with 3.4.
- 224. Outline of training material not in compliance with 3.6.
- 225. Warranty not in compliance with 3.7.

#### 4.4 Testing

4.4.1 Test Procedures. USPS vehicles upon which CNG conversion kits have been installed shall be subject to the tests described below. Failure of any test is cause for rejection. Rejected units may be reworked and resubmitted at the discretion of the Postal Service.

401. Visual Inspection. The vehicles shall be examined to insure compliance with the installation instructions described by 3.3 regarding component location, component mounting, installation of tubing runs and wire runs. Failure to comply with the installation instructions is cause for rejection.

402. Pressure Test. The vehicle offered for test shall be pressurized with natural gas to the design working pressure through the refueling connector. The battery shall be connected and the fuel selection solenoid shall be in the CNG mode. With the ignition "on" and with the filling probe connected the following components will be checked for leaks using a soap and water solution:

- refueling connector
- check valve
- main shut off valve
- fuel cylinder manual shut off valve
- fuel cylinder venting mechanism
- fuel cylinders
- CNG fuel select lockout solenoid
- pressure regulator assembly
- pressure gauge
- tube fitting connections
- threaded connections (if any)

The presence of bubbles indicating a leak of natural gas at any of the above mentioned components shall be cause for rejection.

403. Electrical Tests. With the battery connected, and the refueling probe connected, the vehicle shall not have a circuit through the starting solenoid. The ability to start the engine with the refueling probe installed is cause for rejection.

With the battery connected and the ignition switch in the "on" position sequencing the fuel selection control should cause the respective fuel selection lockout solenoids and the hour meter to cycle from an "in operation" to an "out of operation" mode. Failure of the fuel selection control to control these components is cause for rejection.

With the battery connected, the fuel gauge should indicate fuel quantity and the light should operate with the dash light switch. Failure of the fuel switch to operate as described is cause for rejection.

With the engine running, operation of the fuel selection control should cause the spark advance control to properly set the ignition timing to the proper setting for CNG or gasoline. Failure of the spark advance to function as described is cause for rejection.

404. Gasoline Leak Test. With the engine running in the gasoline mode, leakage of gasoline as a result of the installation shall be cause for rejection.

405. System Performance Test. Each vehicle upon which a CNG conversion kit has been installed shall be subject to a road test to determine compliance to 3.8.1, an emission control test to determine compliance to 3.8.2, and a suspension system test to determine compliance to 3.8.4. Failure of a vehicle to comply with either is cause for rejection. When specified by the Contracting Officer, one sample of each type vehicle being converted shall be subject to a cold temperature starting test to determine compliance to 3.8.3. Failure of a vehicle to comply with the cold temperature start test is cause for rejection of all vehicles of that type. The contractor shall obtain any necessary equipment, such as a refrigerated insulated trailer with vehicle ramps for use as a cold test chamber and any other instrumentation that may be necessary to perform these tests.



<u>Vehicle Type</u> <u>Manufacturer</u>	<u>Description</u> <u>Year</u>	Engine Disp. (CID/L)	No. of Cyl.	Carburetor Type	Required Fuel Capacity	Fuel Cylinder Location	Quantity

TABLE 2- QUALITY ASSURANCE SAMPLING PLAN

This chart is compiled from MIL-STD 105, Sampling Procedures and Tables for Inspection by Attributes and contains information from Table I, Sample Size and Code Letters, and Table II-A, Single Sampling Plan for Normal Inspection (Master Table).

<u>Lot Size</u>	<u>Sample Size</u>	<u>Ac</u>	<u>Re</u>
2-8	2	0	1
9-15	3	0	1
16-25	5	1	2
26-50	8	1	2
51-90	13	2	3
90-150	20	3	4

The following examples are offered as explanations on how the information in the above chart is to be used.

1. If 20 vehicles are being converted, then:

- 5 vehicles have to be inspected in accordance with 4.3.3.
- the lot (20) is rejected if 1 critical defect is found,
- the lot (20) is rejected if 2 or more major defects are found.

2. If 80 vehicles are being converted, then:

- 13 vehicles have to be inspected in accordance with 4.3.3.
- the lot (80) is rejected if 1 critical defect is found,
- the lot (80) is rejected if 3 or more major defects are found.

Rejected lots may be subject to 100% inspection at the discretion of the Postal Service. Defective items may be replaced or reworked and resubmitted at the discretion of the Postal Service.

STATEMENT OF WORK

COMPRESSED NATURAL GAS REFUELING SYSTEM

---

(City)

(State)

## TABLE OF CONTENTS

<b>1</b>	<b>Purpose and Scope</b>
<b>1.1</b>	<b>Purpose</b>
<b>1.2</b>	<b>Scope</b>
<b>2</b>	<b>General Requirements</b>
<b>2.1</b>	<b>Key Personnel</b>
<b>2.2</b>	<b>Engineering</b>
<b>2.3</b>	<b>National Fire Protection Association Standards</b>
<b>2.4</b>	<b>Installation Site</b>
<b>3</b>	<b>General Requirements</b>
<b>3.1</b>	<b>Capacity</b>
<b>3.3</b>	<b>Compressor Unit</b>
<b>3.4</b>	<b>Electrical Work</b>
<b>3.5</b>	<b>Methanol Injection</b>
<b>3.6</b>	<b>Controls</b>
<b>3.7</b>	<b>Gas Storage</b>
<b>3.8</b>	<b>Fast-Fill System</b>
<b>3.9</b>	<b>Refueling Connector</b>
<b>3.10</b>	<b>Time-Fill System</b>
<b>3.11</b>	<b>Concrete Slab</b>
<b>3.12</b>	<b>Compressor Unit Enclosure</b>
<b>3.13</b>	<b>Piping</b>
<b>3.14</b>	<b>Spare Parts</b>
<b>3.15</b>	<b>Training</b>
<b>3.16</b>	<b>Warranty</b>
<b>3.17</b>	<b>Documentation</b>
<b>4</b>	<b>Quality Assurance Provisions</b>
<b>4.1</b>	<b>Responsibility for Inspection</b>
<b>4.2</b>	<b>Inspection of Components, Parts and Materials</b>
<b>4.3</b>	<b>Inspection Procedure</b>
<b>4.4</b>	<b>Testing</b>

1 PURPOSE AND SCOPE

1.1 Purpose. The purpose of this Statement of Work (SOW) is to define the requirements for providing and installing a compressed natural gas (CNG) refueling system at a United States Postal Service (USPS) facility.

1.2 Scope. The scope of this contractual effort covers providing a CNG refueling system as a "turn-key" installation. This effort includes providing and installing all the components necessary to insure the proper performance of the system and the safety of USPS employees and the general public. This includes all the engineering work necessary for the refueling system design, installation, test and acceptance. This effort also includes performing all the necessary performance checks and minor adjustments upon completion of the installation. A requirement exists for providing system documentation as well as training covering the system's operation and maintenance. Finally, a requirement to provide spare parts and labor to support the system for one year must be met.

2 GENERAL REQUIREMENTS

2.1 Key Personnel. The contractor shall assign a single individual to act as project manager for this effort. This individual shall be responsible for coordinating all of the contractor's efforts and for directing all of the contractor's personnel and any sub-contract personnel when working at the designated installation site. The project manager need not be located at this site nor be assigned to the program on a full time basis, but he shall be responsible and answerable for the contractor's efforts and shall be considered to be the contractor's management and technical representative.

2.2 Engineering. The contractor shall be responsible for accomplishing all of the engineering work required to design the CNG refueling system and to install it on the postal site. The contractor shall obtain all the necessary permits required and shall comply with all the applicable codes, rules, and regulations which cover the installation and operation of compressed natural gas refueling systems.

2.3 National Fire Protection Association, Inc. Standards. The contractor's design, components and installation shall comply with the Standard for Compressed Natural Gas (CNG) Vehicular Fuel Systems, NFPA 52, except where modified by this SOW.

2.4 Installation Site. The contractor shall install the CNG refueling system and otherwise comply with the requirements of this SOW at the USPS facility located at:

---

(Street Address)

---

(City)

(State)

(Zip Code)

This facility is under the direction of:

---

(Name)	(Title)
--------	---------

---

(Commercial Phone No.)	(FTS Phone No.)
------------------------	-----------------

The contractor's work schedule or any other administrative matter concerning safety, work rules, etc. while at this facility shall be coordinated with and approved by the facility director or his designated representative. The contractor is responsible for providing all the necessary tools, materials, and equipment required to comply with this SOW.

### 3. GENERAL REQUIREMENTS

3.1 Capacity. The refueling system shall be capable of supporting a fleet of 100 vehicles utilizing a "time-fill" operation. The amount of gasoline required to support this fleet is currently averaging 300 gallons per day. A growth factor of 25% shall be included thereby projecting a fuel utilization of 375 gallons per day. The compressor capacity, allowing a time-fill period of 12 hours, is as follows:

$$\frac{375 \text{ gallons per day} \times 108 \text{ SCF per gallon}}{12 \text{ hours per day} \times 60 \text{ min. per hour}} = 56.3 \frac{\text{SCF}}{\text{MIN}}$$

To provide "fast-fill" capability, a cascade storage system with a 40 gallon equivalent withdrawal capacity (Section 3.7) shall be provided. This cascade shall be refilled as required by the compressor as the fuel reserve is used.

3.2 Site Plan. Figure 3.1 shows the desired installation plan for this facility. The contractor shall prepare a detailed site plan (Section 3.17.1) illustrating his proposed layout including as a minimum piping and electrical wiring runs and locations of components.

3.3 Compressor Unit. The compressor unit shall have the capacity specified in Section 3.1. The compressor unit shall be certified by the original manufacturer as being intended for natural gas use. The unit shall provide a maximum output pressure of 3600 PSIG when operating with an inlet pressure of 5 PSIG. The compressor unit shall be a completely self contained package assembled and tested prior to delivery to the installation site. As a minimum, the compressor unit shall exhibit the following features:

3.3.1 The compressor unit shall be designed for Hazardous Environment, Class 1, Group D, Division 1 use and meet all applicable OSHA requirements.

3.3.2 The compressor unit shall be designed for outdoor service.

3.3.3 The compressor unit shall be powered by an electric motor which utilizes a V-belt drive system. The unit shall be equipped with an hour meter to indicate usage.

3.3.4 The electric motor starter shall be an explosion proof design.

3.3.5 The systems control circuitry shall be designed to "fail-safe".

3.3.6 Pressure gauges and safety valves shall be provided for all compressor stages.

3.3.7 System safety features shall include but not be limited to low oil pressure shutdown, high discharge pressure shutdown, high discharge temperature shutdown, and automatic gas shut off.

3.3.8 The system controls shall provide for automatic start and stop, and allow unloaded re-starts.

3.3.9 Filters shall be provided on both inlet and discharge lines. the discharge filter shall handle oil and water.

3.4 Electrical Work. All electrical equipment and installations shall be in accordance with the National Electrical Code and all applicable state and local codes. It shall be the contractor's responsibility to identify and comply with these requirements. A minimum of three lines shall be run to the compressor unit. These shall be a main power line, a line for the compressor crankcase heater, and a line for a dual outdoor receptacle. Provide outdoor disconnects for these lines.

3.5 Methanol Injection. A methanol injection system to handle the capacity stated in Section 3.1 shall be provided.

3.6 Controls. The control devices shall be designed to operate over the range of environmental conditions that can be expected to be encountered at the installation site identified in Section 2.4.

3.7 Gas Storage. High pressure gas storage to meet the fast-fill requirement shall be contained in a cylinder storage bank cascade. These cylinders shall all be new cylinders which meet DOT requirements for natural gas for the specified service pressure. These cylinders shall be assembled into a steel pallet type storage rack which allows the cascade to be moved as a unit. All cylinders shall be provided with a manually operated shut-off valve and with thermo and pressure controlled safety relief valves. The cascade shall be provided with all required piping per NFPA 52 interconnected into three or more separate banks of cylinders for low, medium and high pressure storage. The use of piping, tubing of fittings having any copper content is prohibited. Brass may be used for valves and pressure relief devices.

3.7.1 The cascade storage system shall incorporate a priority fill unit complete with associated valves, gauges, relief valves and a temperature compensating reference cylinder so as to assure refilling of the cascade in a priority sequence. The high pressure bank shall be first filled followed by the lower pressure banks until 3600 PSIG is reached.

3.7.2 An automatic sequential refueling unit sufficient for a two hose fast fill (Section 3.8) station shall be incorporated into the cascade. This unit shall include all the necessary control and relief valves, gauges, Dome Load Unit, and temperature compensating referenced cylinder to insure proper cascade operation (low pressure bank withdrawal first).

3.7.3 Automatic relief valves shall be provided for each pressure bank of the cascade and they shall be vented to a safe point of discharge.

3.8 Fast-Fill System. A fast-fill system having two fill hoses shall be provided. The system shall be located as shown in Figure 3.1. The fill hose assemblies shall be fourteen (14) feet long with automatic retractor reels and shall be complete with fill valve, refueling connector, and 1/4 turn ball valve shut off. The hose connection to the post shall be of a breakaway design and prevent the escape of gas should the design be actuated. A bleed system shall be provided to permit depressurizing the line prior to disconnecting the vehicle being filled. This bleed line shall lead to a safe venting arrangement. The hose and hose connections shall comply with Section 2.10 of NFPA 52 with the exception that the hose shall be rated at 5000 psi working pressure.

3.9 Refueling Connector. The refueling connector provided shall be a Hansen Quick Coupler, Series 2-HK, manufactured by the Hansen Manufacturing Company, Cleveland, OH. The female portion of the connector shall be mounted on the fill hose.

3.10 Time-Fill System. The 100 vehicles assigned to this facility are to be refueled nightly by the time-fill system. The parking system, compressor system location, and time-fill positions are shown on Figure 3.1. The fill hoses shall be identical to those specified in Section 3.8 and shall utilize the refueling connectors specified in Section 3.9. The poles to which the hoses are attached shall be securely installed by enclosing in concrete and protected from vehicle damage by barrier posts or wheel stops.

3.11 Concrete Slab. The contractor shall install a concrete slab upon which the compressor unit and cascade will be mounted. Asphalt around the slab shall be repaired to provide a flush joint between asphalt and concrete. Repair all asphalt and concrete surfaces dug up as part of this contract and re-paint all parking space lines that were removed. Concrete work shall conform to local standards.

3.12 Compressor Unit Enclosure. The compressor unit shall be enclosed by a structure consisting of two solid walls and two chain-link walls. The structure must provide a clear inside height of at least 6 ft. 6 inches. The solid walls may be either concrete block or steel prefabricated panels. One of the chain-link type walls shall provide a double gate access sufficient in size to allow installation or removal of the compressor as a unit. The roof shall be sufficiently sloped to prevent any escaped gas from remaining within the structure. The chain-link type walls shall be provided with canvas drops and ties to provide protection in inclement weather. Sufficient barrier posts shall be provided around the compressor unit and cascade to prevent damage by vehicles. The appropriate posts shall be removable to allow maintenance or removal of the equipment.



13 Piping. All natural gas piping and tubing shall comply with NFPA and applicable state and local codes. Corrosion protection by either material composition, chemical finish or cathodic protection shall be provided. Color coding shall comply with existing standards for low and high pressure lines.

14 Spare Parts. A one year supply of spare parts for the refueling system shall be provided. The quantities of parts provided shall be based on a system usage of 312 days per year. The parts shall be itemized on a spare parts list which shall provide all information necessary to reorder. The parts identified shall be categorized as "long lead" items and "standard parts". This information shall be provided to the contracting officer.

15 Training. The contractor shall provide training for Postal Service mechanics at the location identified. The training shall include but not be limited to general theory of operation, safety, installation, inspection, testing, diagnostics, and repair procedures. An outline of this course material shall be included in the response to this solicitation.

16 Warranty. All materials and equipment supplied in accordance with this SOW shall be warranted by the contractor for a period of one year or for the period stated by the original component manufacturer, whichever is greater, against all defects in design, materials, and workmanship. This warranty shall include all the parts and labor required to correct defects arising during this time period. Upon notice from the contracting officer, the contractor or provider of warranty services shall promptly correct the problem without cost to the Postal Service. A copy of this warranty with the names, addresses and phone numbers of those providing warranty services must be included in the response to this solicitation.

17 Documentation. The contractor will provide an original and five copies of the following documentation.

17.1 A site plan showing as a minimum the location of the compressor unit, cascade, time and fast fill post locations, and utility meters.

17.2 A compressor unit design layout including the compressor, cascade and control systems.

17.3 Filling post design with details of hoses, fittings, reels, etc.

17.4 System wiring schematic diagrams showing wire size, color, required end conditions, identification of terminals the respective wires connect to, and type and location of wire support device required.

17.5 Piping and tubing schematic diagrams showing pipe and tube types and sizes, fittings, components they connect to, and color coding to indicate pressure levels.

17.6 Operation and Maintenance Manuals for the refueling system which include installation instructions.

#### 4. QUALITY ASSURANCE PROVISIONS

4.1. Responsibility for Inspection. Unless otherwise specified in the contract or purchase order, the contractor is responsible for adjustment, inspection and test of all CNG refueling system components and the installations of these same components at the USPS facility identified in this SOW. The contractor may utilize his own or other inspection facilities and services which are acceptable to the USPS. Records of adjustments, inspections, and tests shall be complete and made available to the USPS who reserves the right to perform any of the inspections or tests specified. Copies of check lists, punch lists, etc. which will be utilized by the contractor shall be provided in the response to this solicitation.

4.2. Inspection of Components, Parts and Materials. The contractor is responsible for ensuring that all components, parts and materials conform to the requirements and references specified herein.

4.3. Inspection Procedures. This section provides Quality Assurance procedures for the procurement of CNG refueling systems. The CNG refueling system shall be inspected in the following areas. Any single area of non-compliance is cause for rejection of the system

- 101. Capacity not in accordance (NIA) with 3.1.
- 102. Compressor NIA 3.3
- 103. Cascade cylinders NIA with 3.1 and 3.7.
- 104. Electrical work NIA with 3.4.
- 105. Methanol injection NIA with 3.5.
- 106. Controls NIA with 3.6.
- 107. VGas Storage NIA with 3.7.
- 108. Fast-Fill system NIA with 3.8.
- 109. Refueling Connector NIA with 3.9.
- 110. Time-Fill system NIA with 3.10.
- 111. Concrete slab NIA with 3.11.
- 112. Compressor Unit Enclosure NIA with 3.12.
- 113. Piping NIA with 3.13.
- 114. Spare Parts List NIA with 3.14.
- 115. Training NIAS with 3.15.
- 116. Warranty NIA with 3.16.
- 117. Documentation NIA with 3.17.

#### 4.4 Testing

4.4.1 Test Procedures. The CNG refueling system installed shall be subject to the tests described below. Failure of any test is cause for rejection. Rejected unit may be reworked and resubmitted at the discretion of the Postal Service.

401. Visual Inspection. The refueling system shall be examined to insure compliance with the requirements described in Section 3 regarding component location, component installation, installation of tubing runs and wire runs, and concrete work. Failure to comply with the installation requirements is cause for rejection.

102. Pressure Test. The refueling system offered for test shall be pressurized with natural gas to the design working pressure using the compressor. All fittings, piping, tubing, etc. shall be checked for leaks using a soap and water solution:

The presence of bubbles indicating a leak of natural gas at any of the above mentioned components shall be cause for rejection.

103. System Performance Test. The refueling system shall be subject to an operational test to determine compliance to Section 3 requirements.

**Appendix C**

**SUPPLIERS OF CNG VEHICLE SUPPLIES AND SERVICES**

# NGV Product & Service Directory

## **Advanced Fuel Components, Inc.**

P.O. Box 168  
Marshall, MI 49068  
616/781-1111

Attn: Hal Babcock  
Accessories: Shut-off valves, fitters

## **Atlas Copco Industrial**

161 Lower Westfield Road  
Holyoke, MA 01040  
413/536-0600

Attn: Jim LaRusso  
Compressors

## **Automotive Natural Gas, Inc.**

201 Park View Drive  
Milton, WI 53563  
608/868-4624

Attn: John Sayre  
Conversion, Dispensing,  
Compressors

## **Autotronic Controls Corporation**

6908 Commerce  
El Paso, TX 79915  
915/772-7431

Attn: Roger Priegel  
Accessories: Electronic Spark  
Advance Timer

## **B&B International Trade**

Via Alidos 36  
40139 Bologna  
Italy

Rubens Basaglia  
Conversion, Diesel

## **Bauer Compressors**

1328 Azalea Garden Road  
Norfolk, VA 23502  
804/855-6006

Attn: Heather Fox  
Compressors

## **Beam Products Manufacturing Company**

3040 Rosslyn Street  
Los Angeles, CA 90065  
913/680-0554

Attn: Mr. Zonker  
Accessories: Pressure Valves,  
Conversion/Carb., Safety and Test  
Equipment

## **Beckwith Machinery Corporation**

3916 Crooked Run Road  
North Versailles, PA 15137  
412/921-2522

Attn: Jim Stephens, Associate  
J. H. Stephens Assoc. Inc.  
P.O. Box 25373  
Pittsburgh 15242

Conversion/Carburetion

## **Bombardier Inc.**

1505 Dickson  
Montreal, Quebec  
Canada H1N 2H7

514/253-7333

Attn: M. L. Payne  
Diesel

## **Brunner Engineering & Manufacturing Inc.**

P.O. Box 1367  
Bedford, IN 47421  
812/275-5931

Attn: Jim Taylor, National Sales  
Manager

Cylinders

## **Carburetion & Turbo Systems, Inc.**

P.O. Box 74  
St. Peter, MN 56082  
507/931-5575

Conversion/Carburetion

## **Chesterfield Cylinders**

P.O. Box 8001  
Enid, OK 73701  
405/235-6300

Attn: Gene Burkett  
Cylinders

## **CNG Cascade Storage Systems, Inc.**

Greenspoint Office Park  
10803 Vestavio Court  
Austin, TX 78747  
512/280-1077

Attn: John Oliphant

Cascades and Storage

## **CNG Fuel Systems**

702-W. 48 Ave.  
Denver, CO 80216  
303/292-4451

Attn: Lynn Lawther  
Conversions, Compressors,  
Dispensing

## **CNG Fuel Systems**

1310 Fewster Drive  
Mississauga, Ontario  
Canada L4W 1A4  
416/629-1699

Attn: Peter Flynn

## **CNG Equipment Rebuilders**

Route 2, Box 21AB  
Mountain Home, AR 72653  
501/425-8884

Attn: Len Bowgen

Compressors Repair, Conversions,  
Parts Supply

## **CNG Inc.**

1845 N. Milwaukee Ave.  
Chicago, IL 60647  
312/227-6278

Attn: Mr. Morris

Conversions

## **CNG Services of Pittsburgh Inc.**

350 Hochberg Rd.  
P.O. Box 278  
Monroeville, PA 15146  
412/531-7072

Attn: Robert Petsinger

Conversions, NGV Services

## **Compair Mako**

1630 S.W. 17th St.  
P.O. Drawer 1630  
Ocala, FL 32678  
904/732-2268

Attn: William Matson

Compressors

## **Controlled Energy Systems**

1070 N.E. 81st Street  
Miami, FL 33160  
305/754-1627

Attn: Ken Green  
(Also see CFS, Inc., below)

Conversion, Compressor Station  
Installation, Diesel

## **Controlled Fuel Systems, Inc.**

3190 S.E. Dominica Terrace  
P.O. Box 2677  
Stuart, FL 33494-2677

305/286-0350 800/327-5911

Attn: Richard C. Ford, President

Conversion/Carburetion, Diesel

## **Corken International Corporation**

P.O. Box 12338  
Oklahoma City, OK 73157  
405/946-5576

Attn: Bill Kennedy, President

Compressors

## **Faber Industrie SPA**

P.O. Box 115-I 33043  
Cividale Del Friuli  
Udine, Italy

(0432) 733161

Attn: Renzo Toffolutti

## **DERECO**

Schlossgasse  
CH-9320 Arbon  
Switzerland  
071/469272

Attn: M. Signer

Conversions, Diesel

## **East Coast Conversions**

P.O. Box 803  
100 Fairfax Street  
Martinsburgh, WV 25401  
304/263-0821

Attn: Bryan Memmott

Conversions, Diesel

## **Energetech/Engenco**

P.O. Box 400  
Midvale, UT 84047-0400  
801/566-5678  
801/566-7744

Attn: Carl Clark

Compressors

## **Fiba**

### **Division of MA Oxygen Equipment Company**

97 Turnpike Road  
Westboro, MA 01581-0446  
617/366-8361

Attn: Bob Arcieri

Conversions, Dispensing

## **Fiba-Canning**

2651 Markham Rd.  
P.O. Box 280  
Agincourt, Ontario  
Canada M1S 3B8  
416/299-1142

Attn: H. Canning

Conversions, Diesel

**Fisher Controls Company**

PO. Box 900  
McKinney, TX 75069

214/542-5512

Attn: Bob Haradon

Dispensing/Measurement: gas  
regulators, level detectors,  
measurement instrumentation

**Fred Holmes Fuel Injection &  
Turbocharger Specialists, Ltd.**

25 Victoria Dr.  
Vancouver, B.C.  
Canada

604/253-7585

Attn: Fred Holmes

Conversions, Diesel

**Fuels Inc.**

PO. Box 1500  
Hartford, CT 06144

203/727-3264

Attn: Peter Casarella

Conversions

**Henderson Company**

PO. Box 830-876  
Richardson, TX 75083

214-234-3226

Attn: Craig Henderson

Cylinders and CNG Tube Trailers

**Garretson Equipment**

PO. Box 111  
W. Industrial Park  
Mt. Pleasant, IA 52641

319/385-2203

Attn: Keith Garretson

Conversions, Carburetion

**The Gales Corporation**

900 South Broadway  
PO. Box 5887  
Denver, CO 80217

303/744-1911

Attn: Sales Department

V-Belts, Timing Belts, Internal  
Combustion Engines

Accessories: Coolant, Heater, Fuel  
Hoses

**Haskel Inc.**

100 E. Graham Place  
Burbank, CA 91502

818/843-4000

Attn: Don Donahue

Compressors (gas driven)

**Hocking Technical College**

Nelsonville, Ohio 45764

614/753-3591

Attn: Jerry Hutton

Training, NGV/compressor  
installation and maintenance

**Illinois Industrial Equipment**

16450 S. 104th Avenue  
Orland Park, IL 60462

312/460-7070

Attn: Doug Johnson

Conversions, Carburetion,  
Compressors

**IMPCO Carburetion Inc.**

16916 Gridley Place  
Cerritos, CA 90701

213/860-6666

Attn: Robert E. Kranz, Jr.

Conversion/Carburetion

**IMW Industries**

45831 Hocking Ave.  
Chilliwack, B.C.  
Canada V2P 1B5

604/792-5660

Attn: D. George Peles

Compressors, dispensers

**Ingersoll-Rand**

5510 77 Center Dr.  
Charlotte, NC 28224  
704/527-0500

Compressors

**Kanton Air Products  
Corporation**

3570 Burnet Ave.  
East Syracuse, NY 13057

315/437-6518

Attn: Peter Kanton

Conversions, Dispensing,  
Compressors, Storage

**Koltec Energy**

PO. Box 3280  
4800 DG Breda  
The Netherlands

Conversion/Carburetion

**L.E. Klein Co., Inc.**

2914 Redward Lane  
Dallas, TX 75220

214/350-4679

Attn: Wayne Prather

Conversions

**Liquid Transfer Systems  
Limited**

6660 Ordan Drive  
Mississauga, Ontario  
Canada L5T 1J7

416/678-6314

Dispensing: Traditional Gasoline  
Pumps

**Luxfer Ltd.**

1995 3rd St.  
Riverside, CA 92517

714/684-5110

Attn: Jim Ament  
Cylinders

**Mark II Innovations**

2785 Kew Drive  
Windsor, Ontario  
Canada N8T 3B7

519/948-3573

Attn: Mike Romeo

Carburetion

**Mech Tech Auto, Inc.**

1368 Glen Rutley Circle  
Mississauga, Ontario  
Canada L4X 1Z6

416/624-8787

Attn: Colin Young

Conversion/Training

**Methane Technologies**

919 Houser Way North  
Benton, WA 98055

206/228-0200

Attn: Paul Griff

Compressors

**Micromotion**

7070 Winchester Circle  
Boulder, CO 80301

Attn: Dean Lowe—303/530-8513

Randy Jensen—303/530-0530

Dispensing, Metering

**Mississippi Tank Company**

3000 West 7th St.  
Hattiesburg, MS 39401

800/331-8265

Attn: Mike Pitts

Cylinders

**Mogas**

1295 Seymour St.  
Vancouver, B.C.  
Canada V6B 3N6

604/669-1165

Attn: Tony Filetti

Conversions, Diesel

**New England Instrument  
Company**

Kendall Lane  
Natick, MA 01760

617-875-9711

Pressure Sensors/Fuel Gauges

**NI Industries**

PO. Box 7486  
Long View, TX 75606

214/757-7633

Attn: Mr. McSweeney

Cylinders

**Norwalk Company**

PO. Box 548, Northwater St.  
South Norwalk, CT 06856

205/838-4766

Attn: John Bautzman

Compressors, Conversion,  
Dispensers

**Pacer Industries Inc.**

9101 Ely St.  
Pensicola, FL 32514

904/476-0907

Attn: Doug Proffitt

Conversions, Carburetion

**Pacer Industries Inc.**

9101 Ely St.  
Pensacola, FL 32514

904/476-0907

Attn: Doug Proffitt

Conversions, Carburetion

**Petro Systems International**

402 Harding Ind. Drive  
Nashville, TN 37311

615/834-7117

Attn: Paul Morgan

Conversion/Carburetion

**Petro Vend, Inc.**

9128 West 47th St.  
Brookfield, IL 60513

312/485-4200

Attn: Jules Roels

Dispensing: Fleet Fueling Controls

**Pignone Inc.**

10777 Westheimer, Suite 920  
Houston, TX 77042

713/952-8374

Attn: Marcello Bologna

Products, Compressors,  
Dispensing, Complete Stations

**Presscon**

5069 Beresford St.  
Burnaby, B.C.  
Canada V5J 1H8  
604/437-0161

Attn: Willie Romero  
Dispensers

**National Fuel Corporation**

7353 6th Street  
Burnaby, B.C.  
Canada V3N 3L2  
604/526-2728

Attn: Steve Addison

**National Joy CNG Systems**

18 Harrison St.  
P.O. Box 31  
Zanesville, OH 43702-0031  
614/454-0194

Attn: Richard Ridenour  
Conversions

**NCF Industries**

2320 Cherry Ind. Circle  
Long Beach, CA 90805  
213/630-5768

Attn: Norm Fawley  
Conversions

**Nelson Dunn, Inc.**

940 South Vail Ave.  
Montebello, CA 90640  
213/735-3705

Attn: Kevin Dunn  
Carburetion

**Pressed Steel Tank Company**

P.O. Drawer 10-J  
Milwaukee, WI 53201  
414/476-0500

Attn: John Dimmick  
Cylinders

**The Promatic Corporation  
(formerly Tillman)**

700 W. Beardsly Ave.  
Elkhart, IN 46514  
219/293-9245

Carburetion

**Pro-Staff Fuels Ltd.**

P.O. Box 91016 West  
Vancouver, B.C.  
Canada V7V 3N3  
604/922-8075

Attn: Joe Foster  
Conversions, Diesel

**Rix Industries**

6460 Hollis St.  
Emeryville  
Oakland, CA 94662  
415/658-5275

Attn: Jack Hall  
Compressors

**Rodagas Energy Systems, Inc.**

30121 Grosebeck Highway  
Roseville, MI 48066  
313/773-5790

Attn: Eric Anderson  
Carburetors: Low Pressure  
Storage

**Sherwood Division Harsco**

120 Church St.  
Lockport, NY 14094  
716/433-3891

Attn: Joseph Pirrone  
Special Accessories: High Pressure  
Valves

**Southern Cross Corporation**

P.O. Box 2168  
Norcross, GA  
404/441-0403

Attn: David Crawford  
Conversions, Dispensing,  
Compressors, Training

**J. H. Stephens, Inc.**

(See Beckwith Machinery Corp.)

**Structural Composites Inc.**

325 Enterprise Place  
Pomona, CA 91768  
714/594-7777

Attn: Don Neff  
Cylinders

**SULZER**

60 Bloor Street, West Suite 803  
Toronto, Ontario  
Canada M4W 3B8  
416/923-2034

Attn: Walter Bernard  
Compressors

**Superior Industries  
Division of Drum Engineering,  
Inc.**

5800 Poplar Level Rd.  
Louisville, KY 40218  
502/964-5939

Dispensers, Measurement

**Taylor-Wharton Company**

P.O. Box 2365  
Harrisburg, PA 17105  
717/234-8021

Attn: J. A. Farina  
Cylinders

**Thermal Efficiency, Inc.**

P.O. Box 2304  
Seattle, WA 98111  
206/622-6788

Attn: George F. Ledbetter  
Conversions

**TNO Road-Vehicles, Research  
Institute**

P.O. Box 237  
23600 AE Delft  
Schoemakerstraat 97  
Delft, Holland

31-15-56-93-30

Attn: Pier Tiedma  
Conversions, Diesel

**Total Fuels**

P.O. Box 87  
263 2nd St.  
Niwot, CO 80554

303/444-4792

Attn: Gary Lewis  
Conversions, Compressors

**Tri Fuels**

P.O. Box 1466  
Sercy, AR 72143  
Conversions

**USX****Christy Park Plant**

2214 Walnut St.  
McKeesport, PA 15132  
412/664-6604

Attn: J. P. Nasci

Underground Tanks, Cylinders

**Wilijay Corporation**

P.O. Box 5331  
Bethlehem, PA 18105  
215/770-1333

Attn: Dan Gigante  
Compressors

**Winton Products Company  
Inc.**

Box 36332  
Charlotte, NC 28236  
704/399-5151

Leak Detectors

---

The American Gas Association has compiled this list of NGV equipment and services vendors from publically available industry information, to be as inclusive as possible. Inclusion on this list in no way implies endorsement, sponsorship, or approval of equipment, services or companies. Any NGV vendor of equipment or services not included, or requiring a change or addition of information included herein, should contact, in writing A.G.A., NGV Marketing, 1515 Wilson Blvd., Arlington, Virginia 22209.

---

Company	Conversion &		Dispensing &		Cylinders	Special Accessories	Training	Comments
	Diesel	Carburetion	Measurement	Compressors				
Advanced Fuel Components, Inc.						•		Shut off valves; filters
Atlas Copco Industrial Compressors, Inc.				•				Distributes compressors and cylinders.
Automotive Natural Gas, Inc.		•	•	•		•		Sells dual fuel systems replacement parts
Autotronic Controls Corporation						•		Electronic Spark Advance Timer
B&B Engineering S.r.l.	•	•						
Bauer Compressors				•				
Beam Products Manufacturing Co.		•				•		Pressure valves; safety and test equipment
Beckwith Machinery Corporation		•	•					
Bombardier Inc.	•							
Brunner Engineering and Manufacturing, Inc.					•			Manufacturer
Carburetion & Turbo Systems, Inc.		•						
Chesterfield Cylinders					•			Manufacturer
CNG Cascade Storage Systems, Inc.					•	•		Cascade Storage, priority valves, sequential valve systems
CNG Fuel Systems		•	•	•	•		•	
CNG Equipment Rebuilders		•						
CNG Inc.		•						
CNG Services of Pittsburgh, Inc.								
Compair Mako				•				
Controlled Energy Systems	•	•						Will install compressor stations
Controlled Fuel Systems, Inc.	•	•						
Corken International Corporation			•	•				
DERECO	•							
East Coast Conversions	•	•						Sells on-board fuel gauge
Energetech/Engenco				•				
Faber Industrie SPA					•			Manufacturer
Fiba		•	•	•				
Fiba-Canning	•							
Fisher Controls Company			•			•		Regulators, level detectors
Fred Holmes Fuel Injection and Turbocharger Specialists, Ltd	•	•						
Fuels, Inc.		•			•			
Garretson Equipment Company, Inc.		•						Specializes in fuel mixers, including diesel



	Conversion & Diesel	Carburetion	Dispensing & Measurement	Compressors	Cylinders	Special Accessories	Training	Comments
Gates Corporation, The						•		V-belts, timing belts, fuel hoses, coolant
Haskel, Inc.				•				
Henderson Company					•			CNG tube trailers
Hocking Technical College							•	
Illinois Industrial Equipment		•		•				
IMPCO Carburetion Inc.		•					•	
IMW Industries				•				
Ingersoll-Rand				•				
Kanton Machine Corporation		•	•	•	•			
Koltec Energy		•						
L.E. Klein Co., Inc.		•						
Liquid Transfer Systems Limited			•					
Luxfer Ltd.					•			
Mark II Innovations		•						carburetors
Mech Tech Auto, Inc.		•						
Methane Technologies				•				
Micro-Motion			•					
Mississippi Tank Company					•			Manufacturer
Mogas	•							
National Fuel Corporation		•	•					
National Joy CNG Systems		•						
NCF Industries		•						
Nelson Dunn, Inc.		•						carburetors
New England Instruments						•		Pressure and fuel gauges
NI Industries					•			Manufacturer
Norwalk Company		•	•	•	•			
Pacer Industries Inc.		•						
Petro Systems International		•	•					
Petro Vend, Inc.			•					
Pignone, Inc.			•	•				
Presscon			•					
Pressed Steel Tank Co.					•			Manufacturer
The Promatic Corporation		•						
Pro-Staff Fuels Ltd.	•							
Rix Industries				•				
Rodagas Energy Systems, Inc.		•			•			
Sherwood Division Harsco						•		high pressure valves

	Conversion & Diesel	Dispensing & Carburation	Measurement & Compressors	Cylinders	Special Accessories	Training	Comments
Southern Cross Corporation		•	•	•		•	
Structural Composites, Inc.					•		Manufacturer
Sulzer Canada Inc.			•				
Superior Industries			•				
Taylor-Wharton Co.				•			Manufacturer
Thermal Efficiency, Inc.		•					
TNO Road-Vehicles	•	•	•				
Total Fuels		•	•				
Tri-Fuels		•	•	•			
USX				•			Manufacturer, ASME pressure vessels
Wiljay Corporation			•				
Winton Products Co.					•		chemical leak detector

**Appendix D**

**A.G.A. REQUIREMENTS FOR NATURAL GAS  
VEHICLE (CNG) CONVERSION KITS\***

The contents of this appendix are used  
with the permission of the American Gas  
Association Laboratories, Cleveland, Ohio.

\*The American Gas Association is planning to update this document  
in the near future.

**A.G.A. REQUIREMENTS FOR  
NATURAL GAS VEHICLE (CNG) CONVERSION KITS**

**No. 1-85**

**August 20, 1985**

**American Gas Association Laboratories  
8501 East Pleasant Valley Road  
Cleveland, OH 44131  
(216) 524-4990**

## PREFACE

These requirements were developed by the American Gas Association (A.G.A) in response to a growing need in the natural gas vehicle (NGV) industry for guidelines pertaining to the assembly of equipment installed on a motor vehicle in order to operate it alternatively on either gasoline, compressed natural gas (CNG), or only CNG. The requirements form the basis of A.G.A.'s program to certify NGV conversion systems to help promote the safe development and installation of these systems by manufacturers and installers.

The A.G.A. Requirements are in compliance with NGV equipment and fueling station standards published by the National Fire Protection Association in 1984 (NFPA-52) Compressed Natural Gas (CNG) Vehicular Fuel Systems. While NFPA-52 addresses a complete range of NGV components, including the design and installation of fueling stations, the A.G.A. Requirements apply only to on-board natural gas vehicle equipment as an assembly - or system - designed to operate a dual fuel gasoline/natural gas vehicle or dedicated natural gas vehicle. As such, NGV conversion system manufacturers can receive certification of their systems based on the A.G.A. Requirements.

## HISTORY

The first draft was developed by A.G.A. and presented to the A.G.A. Natural Gas Vehicle Committee on September 4, 1984. An ad hoc group of A.G.A. members, utilities and NGV system manufacturers/installers, was formed to review the requirements and develop the final version. The ad hoc group met in Cleveland, Ohio December 6-7, 1984, to process comments and develop the second draft. The second draft was reviewed on January 23, 1985, in Phoenix, and presented to A.G.A.'s NGV Committee. The third draft was then developed and comments on the draft were reviewed on August 20, 1985, in Cleveland, Ohio. The results of this meeting, the final version, were presented to A.G.A.'s NGV Committee in Nashville, Tennessee on October 7, 1985.

## TABLE OF CONTENTS

	<u>Page</u>	
<b>PART I</b>		
<b>CONSTRUCTION</b>		
1.1	Scope	1
1.2	General Construction and Assembly	1
1.3	Fuel Storage System	2
1.4	Tubing and Fittings	3
1.5	Pigtails	4
1.6	Manual Valves	4
1.7	Sealing System	7
1.8	Electrically Operated Solenoid Valve	7
1.9	Natural Gas Carrying Hose	8
1.10	Vacuum Hose	8
1.11	Gasoline Hose	8
1.12	Water Hose	8
1.13	Gas Pressure Regulators	8
1.14	Gas-Air Mixers	11
1.15	Fueling Connection and Safety Devices	11
1.16	Electrical Equipment and Wiring	12
1.17	Gages	16
1.18	Gage Isolator	16
1.19	Marking	16
	Data Plate	18
	Components	19
	Identification	20
1.20	Installation Instructions	20
1.21	Operating and Maintenance Instructions	21

## CONTENTS

<b>PART II</b>	<b>PERFORMANCE</b>	
2.1	General	22
2.2	Tubing and Fittings	22
2.3	Manual Valves Other Than Cylinder Valves	23
2.4	Cylinder Mounting Hardware	26
2.5	Sealing System	26
2.6	Regulators and Regulator Systems	28
2.7	Gas-Air Mixers	32
2.8	Gage Isolator	33
2.9	Marking Material Adhesion and Legibility	34



## GLOSSARY

Construction, Part I, as used in these A.G.A. Requirements, is concerned with criteria for the evaluation of the minimal physical attributes of component materials, labelling, and instructional material considered necessary for reasonable system life, for proper identification of responsible parties, and for safe installation practices.

Performance, Part II, as used in these A.G.A. Requirements, is concerned with criteria for the evaluation of the minimal operating characteristics of the system components considered necessary for the proper and safe operation of a design certified vehicular conversion kit.

Manufacturer, as used in these A.G.A. Requirements, refers to the individual or organization which assembles the components necessary to provide for the complete installation (less storage containers) of a natural gas fuel system on a vehicle. The manufacturer may or may not produce in his facility one or more of the necessary components.

Pigtail, as used in these A.G.A. Requirements, is a tubing that has an outside diameter of 3/16 to 1/2 inch and is provided with a connecting fitting on each end. A pigtail may be in the curved form, or it may be provided with a loop or coil in the tubing.

## PART I

### CONSTRUCTION

#### 1.1 SCOPE

1.1.1 The application of this standard is limited to newly produced CNG vehicular conversion kits constructed entirely of new unused parts and materials suitable for working pressures as specified by the kit manufacturer.

Newly qualified used containers certified by an authorized agency will comply with the intent of this section.

1.1.2 The kit manufacturer shall supply, in one or more packages, container mounting brackets and those parts downstream of the container valve outlet necessary to accomplish a complete vehicle conversion, including intermediate components to connect to engine carburetor and controls.

#### 1.2 GENERAL CONSTRUCTION AND ASSEMBLY

1.2.1 Construction of a CNG conversion kit, whether specifically covered by the various provisions of these requirements or not, shall be in accordance with reasonable concepts of safety and durability.

1.2.2 All specifications as to construction set forth herein may be satisfied by the construction actually prescribed or by such other construction as will provide at least equivalent performance.

1.2.3 Any factory produced subassemblies shall be of a neat and workmanlike character with all components well fitted.

1.2.4 The construction of all parts shall be such that it will not become bent, broken or otherwise damaged during installation or in specified tests of components as prescribed in these requirements. Forming of parts in place for proper installation is acceptable.

1.2.5 Nuts, bolts and screws used in the assembly of a conversion kit shall be of corrosion resistant material or coated with a corrosion resistant material.

1.2.6 All components subject to exposure to weather and other corrosive elements shall be of corrosion resistant material or otherwise protected.

#### 1.3 FUEL STORAGE SYSTEM

##### 1.3.1 Container

CNG fuel container(s) if provided shall be Department of Transportation (DOT) or American Society of Mechanical Engineers (ASME) qualified for use with natural gas at no less than the system working pressure.

##### 1.3.2 Mounting Rack

a. Container mounting racks and instructions for installation shall be supplied by the conversion kit manufacturer.

b. Provision shall be made to secure the mounting rack to the vehicle by means of welding, bolting or equivalent means in such a manner as to withstand the forces applied as specified in Section 2.4.

c. Rack material, if of dissimilar metal, shall be electrically insulated from the container(s) to prevent electrolytic action and fretting corrosion.

d. Racks shall be designed to prevent container rotational displacement.

e. Each fuel supply container in the rack shall be secured to its cradle in such a manner that it is capable of

distance from the center line of the plug to the center of the wrench grip on the inlet connection. For a valve having an outlet side shorter than the inlet, the center of impact shall be 1/4 inch (6.4 mm) from the extreme outlet end.

The valve shall then be struck four successive times at right angles to the longitudinal center line of the outlet gasway, with the valve being turned 90 degrees (1.57 rad) between each impact. After each impact, the valve shall be examined visually for cracks and breakage.

1.6.9 Screw threads of manual valves other than container valves shall comply with the provisions of ANSI B2.2 Dryseal Pipe Threads.

#### 1.7 SEALING SYSTEM

1.7.1 Kit manufacturers shall provide a sealing system (impervious to the action of natural gas and suitable for use at temperatures between -40°F and 180°F) to isolate valve and manifold assembly gas leakage from confined vehicular spaces.

1.7.2 Adhesives, if used, shall be suitable for use at temperatures between -40°F and 180°F and shall be impervious to the action of natural gas.

#### 1.8 ELECTRICALLY OPERATED SOLENOID VALVE

1.8.1 Solenoid valves shall be suitable for the working pressure and fluids to which they will be subjected and shall comply with applicable provisions of UL 429-1982, Valves for Flammable Fluids.

1.8.2 Valves shall be tested for operation at an ambient temperature range of -40°F to 250°F.

#### 1.9 NATURAL GAS CARRYING HOSE

1.9.1 Hose for applications at a working pressure not in excess of 350 PSIG shall comply with applicable provisions of UL 21-1980.

1.9.2 Hose shall be resistant to vacuum collapse at a test pressure of 20" Hg. absolute.

1.9.3 Hose shall be tested at an ambient temperature range of -40°F to 250°F.

#### 1.10 VACUUM HOSE

Vacuum hose in sizes up to 1/2 inch, if used, shall comply with applicable provisions of SAE Standard 30R8, Fuel and Oil Hose, J30-1982.

#### 1.11 GASOLINE HOSE

1.11.1 Gasoline hose, if provided, shall comply with the applicable provisions of UL 330-1978, and shall be resistant to the action of gasoline fuel.

1.11.2 Gasoline hose, if provided, shall comply also with the specifications for SAE R7 or R8 low pressure coupled and uncoupled synthetic rubber tube and cover per SAEJ30 standard.

1.11.3 Gasoline hose shall be secured to tubing and operating components by means other than friction. Adhesives, if used, shall be resistant to the action of gasoline fuel.

#### 1.12 WATER HOSE

Water hose, if used, shall comply with applicable provisions of SAE Standard J20E, Coolant System Hose, Part III, SAE20R3 Heater Hose 1974.

#### 1.13 GAS PRESSURE REGULATORS

1.13.1 Bodies of gas pressure regulators shall be made of material suitable for

- 1.6.3 Manual valves shall function satisfactorily at temperatures from -40°F to 250°F.
- 1.6.4 Valves shall be provided with means to compensate for manufacturing tolerance variations, displacement of lubricants, and for wear which may occur.
- 1.6.5 Valve handles shall be provided and shall be securely attached to the rotor member of the valve.
- 1.6.6 Emergency shutoff valves shall have no more than 90° rotation from "on" to "off" positions and shall be provided with rigidly secured stops to limit rotation. In the "off" position valve handles shall be crosswise to the direction of flow at the valve inlet.
- 1.6.7 A valve designed to be connected directly to threaded fittings shall be capable of withstanding without deformation, breakage or leakage the turning effort exerted to install the valve as specified below.

<u>Nominal Pipe Size, Inches</u>	<u>Turning Effort Inch-Pounds</u>
1/8	170
1/4	220
3/8	280
1/2	375

**Method of Test**

This test shall be conducted at room temperature. Five new valves shall be subjected to this test, all of which shall comply. The turning effort shall be applied to the wrench grip of the valve adjacent to where it is attached to the piping or, if no wrench grip is provided, to the body of the valve by use of a tool which fits snugly about the body of the valve. The turning effort specified shall be applied to the completely assembled valve to screw it into an extra heavy pipe fitting of suitable size.

For a valve having both inlet and main outlet threaded for connection to iron pipe, the turning effort shall be applied for 15 minutes, and the valve shall be subjected, while the turning force is applied, to the leakage test specified in 2.3.2. The turning force shall then be released and the valve removed and examined for deformation and breakage. The valve shall then be subjected again to the leakage test specified in 2.3.2.

For a valve having only one threaded connection for iron pipe, the turning effort shall be applied for 15 minutes, then released, and the valve removed and examined for deformation and breakage. The valve shall then be subjected to the leakage test specified in 2.3.2.

- 1.6.8 Manual valve bodies shall be capable of withstanding the impacts specified below without cracking or breaking.

<u>Nominal Pipe Size, Inches</u>	<u>Impact Foot-Pounds</u>
1/4	10
3/8	15
1/2 and larger	20

**Method of Test**

This test shall be conducted at room temperature.

The valve under test shall be supported by securing it to a close pipe nipple of extra strong Schedule 80 pipe or a standard-weight pipe coupling mounted on a rigid surface so that the free length of the nipple or coupling is not greater than 1 inch (25.4 mm). The outlet end of the valve shall have assembled to it a fitting of the type for which designed. The test device shall be arranged so that the center line of contact between the striking weight and the outlet side of the valve body will be as far from the center line of the plug as the

withstanding a static force applied in the six principal directions (See Figure 1.3.2e) of eight times the weight of the fully pressurized container with a maximum displacement of 1/2 in. (12.7 mm).

Figure 1.3.2e The Six Principal Directions

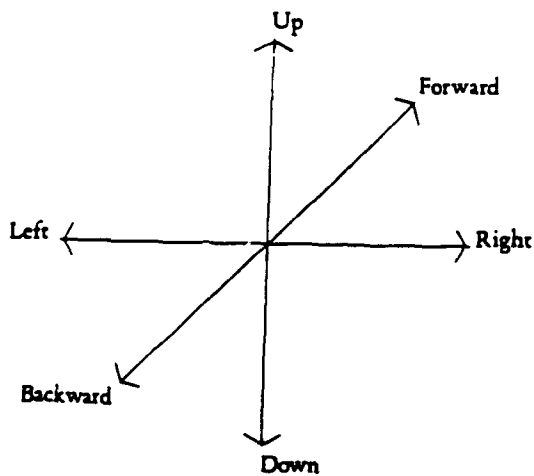

f. Racks shall be capable of disassembly, to the degree necessary to replace a container(s), and of reassembly.

g. Racks shall secure the fuel containers by means other than outlet valves or manifold assembly.

## TUBING AND FITTINGS

1 Tubing and fittings used as a conveyance of gaseous fuel at the manufacturer's specified maximum working pressure shall be of AISI-304 or 316 stainless steel or a ferrous material coated with a durable chemically neutral material which will insulate the tubing and fittings from corrosive road compounds.

2 Tubing and fittings shall be suitable for the working pressure to which they are subjected.

1.4.3 Provision shall be made to minimize vibration of tubing and fittings in vehicular installations. Such provisions must be insulated from tubing and fittings to prevent corrosion by electrolytic action. Such provisions shall be capable of securing tubing at intervals of not more than 24" and in accordance with the manufacturer's instructions. Securing devices shall be sized to retain the tubing in its designed position.

1.4.4 Grommets or similar devices shall be supplied where necessary to prevent abrasion of supply lines which pass through metal panels and shall provide a snug fit to the panel.

1.4.5 Fittings and tubing shall be of the same material. All fittings of the same size provided in the conversion kit shall be of the same manufacturer.

## 1.5 PIGTAILS

1.5.1 Pigtails or equivalent shall be used in manifolding multiple container assemblies and shall be suitable for the manufacturer's specified working pressure.

1.5.2 Pigtails shall comply with applicable provisions of UL 569-1980.

## 1.6 MANUAL VALVES

### 1.6.1 Manual Valves Other Than Container Valves

Bodies of manual valves shall be made of material suitable for use with natural gas and shall be capable of withstanding temperatures of 800°F.

1.6.2 Manual valves shall bear the manufacturer's identifying name or mark and a distinctive model designation.

use with natural gas and shall be capable of withstanding temperatures of 800°F.

1.13.2 Low pressure chambers shall provide for over pressure relief or be able to withstand the operating pressure of the upstream pressure chamber.

1.13.3 A regulator designed to be connected directly to threaded piping shall be capable of withstanding, without deformation, breakage, or leakage, the turning effort exerted to install the regulator as specified in the following table.

<u>Nominal Pipe Size, Inches</u>	<u>Turning Effort Inch-Pounds</u>
1/8	170
1/4	220
3/8	280
1/2	375

#### Method of Test

This test shall be conducted at room temperature. Five new regulators shall be subjected to this test, all of which shall comply. The turning effort shall be applied to the wrench grip of the regulator adjacent to where it is attached to the piping or, if no wrench grip is provided, to the body of the regulator by use of a tool which fits snugly about the body of the regulator. The turning effort specified shall be applied to the completely assembled regulator to screw it into an extra heavy pipe fitting of suitable size.

For a regulator having both inlet and outlet threaded for connection to iron pipe, the turning effort shall be applied for 15 minutes, and the regulator shall be subjected, while the turning force is applied, to the leakage test specified in 2.6.1(a). The turning force shall then be released and the regulator removed and examined for deformation and breakage. The regulator shall then be subjected again to the leakage test specified in 2.6.1(a).

For a regulator having only one threaded connection for iron pipe, the turning effort shall be applied for 15 minutes, then released, and the regulator removed and examined for deformation and breakage. The regulator shall then be subjected to the leakage test specified in 2.6.1(a).

1.13.4 Gas pressure regulators shall be capable of withstanding the impacts specified in the following table without cracking or breaking.

<u>Nominal Pipe Size, Inches</u>	<u>Impact Foot-Pounds</u>
1/4	10
3/8	15
1/2 and larger	20

#### Method of Test

This test shall be conducted at room temperature.

The regulator under test shall be supported by securing it to a close pipe nipple of extra strong Schedule 80 pipe or a standard-weight pipe coupling mounted on a rigid surface so that the free length of the nipple or coupling is not greater than 1 inch (25.4 mm). The outlet end of the regulator shall have assembled to it a fitting of the type for which designed. The test device shall be arranged so that the center line of contact between the striking weight and the outlet side of the regulator body will be as far from the center line as the distance from the center line to the center of the wrench grip on the inlet connection. For a regulator having an outlet side shorter than the inlet, the center of impact shall be 1/4 inch from the extreme outlet end.

The regulator shall then be struck four successive times at right angles to the longitudinal center line

of the outlet gasway, with the regulator being turned 90 degrees (1.57 rad) between each impact. After each impact, the regulator shall be examined visually for cracks and breakage.

#### 1.14 GAS-AIR MIXERS

1.14.1 Components of gas-air mixing devices shall be of corrosion resistant material or have a corrosion resistant finish. Adapters, if used, shall comply with this provision.

1.14.2 Provision shall be made for installation of an air filter ahead of the mixing device.

1.14.3 Nonmetallic components shall be resistant to the effects of natural gas, gasoline and other atmospheres common to vehicular engine compartments.

1.14.4 Nonmetallic components shall be suitable for use at temperatures between -40°F and 250°F.

1.14.5 Moving parts shall operate freely and maintain operating integrity over the temperature range of -40°F and 250°F before and after continued operation, as prescribed under 2.7.

1.14.6 Electrical components, if used, shall be suitable for the intended use and shall be wired in accordance with 1.16 Electrical Equipment and Wiring.

#### 1.15 FUELING CONNECTION AND SAFETY DEVICES

1.15.1 A check valve shall be provided between the fill connection and the vehicle fuel distribution system.

1.15.2 The check valve shall operate to prevent escape of gas in the event of fill connection failure and shall comply with the applicable provisions of UL 125-1980 at temperatures of -40°F and 250°F.

1.15.3 A vehicle fueling connection shall provide for the reliable and secure connection of the fuel system containers to a source of high pressure natural gas.

1.15.4 The fueling connection shall be suitable for the pressure expected under normal conditions and corrosive conditions which might be encountered.

1.15.5 The refueling receptacle on an engine fuel system shall be firmly supported, and shall:

(a) Receive the fueling connector and accommodate the working pressure of the vehicle fuel system, and

(b) Incorporate a means to prevent the entry of dust, water and other foreign material. If the means used is capable of sealing system pressure it shall be capable of being depressurized before removal, and

(c) Have a different fueling connection for each pressure base vehicle fuel system.

1.15.6 If the probe type, the fueling connection shall comply with construction provisions of the Compressed Gas Association Standard, CGA-V-8, Standard For CNG Vehicular Fueling Connections.

1.15.7 If of the quick disconnect type, the fueling connection shall comply with applicable construction provisions of the American National Standard for Quick Disconnect Devices for Use with Gas Fuel, ANSI Z21.41.

1.15.8 All components of fuel connections shall be suitable for use with natural gases at system working pressures and at temperatures of -40°F and 250°F.

#### 1.16 ELECTRICAL EQUIPMENT AND WIRING

This section covers CNG vehicle conversion kits which are equipped for use with electrical energy from an

external source by means of connection to a direct current vehicle circuit 30 volts or less.

#### Method of Test

1.16.1 Electrical equipment, wiring and accessories built in or supplied shall be furnished with the kit.

1.16.2 Electrical equipment and circuit wiring supplied in a kit shall be approved types or shall be investigated as integral parts of the kit for construction and performance equivalent to approved types. Electrical equipment and wiring shall also be judged with respect to their suitability for the particular application (i.e., oil and gasoline resistant covering).

Wiring used in direct current circuits shall be of stranded copper not less than No. 22 AWG, be provided with insulation as required for line-voltage alternating current circuitry, and have adequate current-carrying capacity.

Electrical equipment and wiring listed or certified by a nationally recognized testing agency qualified to certify or list electrical equipment or wiring shall be deemed to be of an approved type.

1.16.3 Wire ends may be left without termination fittings in anticipation of fittings to be provided by the kit installer or may be provided with a standard SAE type of termination fitting.

1.16.4 Provision shall be made for strain relief between wiring and the components to which it connects whenever the conditions of normal servicing create the likelihood of placing a strain on wiring junctions.

A pull of 35 pounds shall be applied to the wiring for a period of one (1) minute without damage to the connection. If screw-type terminals are used, the screws shall be loosened before applying the force. This test need not be conducted if the assembly is of an approved type.

1.16.5 In order to prevent abrasion of the insulation, openings in metal walls through which insulated wires not in wireways pass shall be provided with smoothly rounded bushings or an acceptable metal grommet. Bushings shall be phenolic, porcelain, hard fiber or other suitable material having a smoothly rounded surface.

1.16.6 A lamp holder, panel mounted fuse holder, receptacle or similar device provided as a part of a kit shall incorporate secure mounting means and shall be prevented from turning by means other than friction between surfaces.

1.16.7 An overcurrent protective device shall be located as close as practical to the point of electrical supply connection. It shall be installed in the positive line and be accessible for servicing when the kit is installed in accordance with the manufacturer's installation instructions.

An overcurrent protective device shall not be rated in excess of the ampacity of the conductors in the kit circuit.

1.16.8 Circuit breakers or fuses shall be of a listed or approved type, including automotive types conforming to the requirements of Society of Automotive Engineers ANSI/SAE J554b-1978, Electric Fuses (Cartridge Type), or Underwriters Laboratories' Standard for Automotive Glass-Tube Fuses, UL 275-1978.

1.16.9 Materials used for electrical construction shall be suitable for their particular application.



In determining the acceptability of an electrical insulating material, consideration shall be given to its mechanical strength, dielectric strength, heat-resistant properties, the degree to which it is enclosed or protected, and any other features having a bearing on the fire and accident hazards involved.

- 1.16.10 Single-pole switches, including those of safety controls and protective devices, shall not be wired in neutral or grounded lines.
- 1.16.11 Electrical equipment and wiring shall have insulation suitable for a temperature of 250°F.
- 1.16.12 Adequate dielectric shall be interposed between ungrounded current carrying parts and those external surfaces which can be contacted.

#### Method of Test

When connected to a supply circuit of rated voltage and frequency, the kit components shall be operated and the dielectric test(s) outlined below shall be conducted.

If the kit employs a component(s), such as a solid-state device, that can be damaged by the dielectric potential(s) specified in this provision, the point of connection of this component(s) to the chassis ground shall be disconnected for the purpose of this test in order to eliminate the likelihood of component damage while still retaining representative dielectric stress of the circuit.

Kit components shall be capable of withstanding, for 1 minute without breakdown, the application of a 60-cycle alternating potential of 500 volts applied between live parts and dead-metal parts.

The arrangement of the test circuit shall be such that if the dielectric material breaks down, a positive signal will be obtained, rather than depending upon a visual inspection of the material.

#### 1.17 GAGES

- 1.17.1 An electrical or mechanical fuel gage shall be provided.
- 1.17.2 A mechanical gage, if provided, shall comply with the construction provisions of UL 404-1979 and shall be capable of reading working pressure  $\times 1.2$ .
- 1.17.3 Gages shall be suitable for operation over a temperature range of -40°F to 180°F if cab mounted, or to 250°F if mounted in engine compartment.

#### 1.18 GAGE ISOLATOR

- 1.18.1 A gage isolator, mounted outside of the passenger compartment, shall be provided in gage tubing lines which communicate with the passenger compartment.
- 1.18.2 Gage isolators shall be suitable for the working pressures and fluids to which they will be subjected, and marked to indicate proper installation.
- 1.18.3 Gage isolators shall be suitable for use over a temperature range of -40°F and 250°F.

#### 1.19 MARKING

- 1.19.1 Marking material shall be identified by class number and shall meet the following specifications. All metal marking materials shall be rust-proof. All markings shall be suitable for application to surfaces upon which applied. The designation of any class of marking shall not preclude the use of marking of a lower number class.

### Class I. Integral Marking

Marking that is embossed, cast, stamped or otherwise formed in the part. This includes markings baked into an enameled surface.

#### Class IIA-1. Permanent Plate

Shall be made of metal having a minimum thickness of 0.012 inch (0.30 mm), shall be securely attached by mechanical means and shall comply with 2.9.

#### Class IIA-2. Permanent Plate

Shall be made of metal having a thickness of 0.006 to 0.012 inch (0.15 to 0.30 mm), shall have mechanical attachment means at all corners with a maximum spacing of 6 inches (152 mm) between mechanical fasteners and shall comply with 2.9.

#### Class IIA-3. Permanent Plate

Shall be made of metal having a thickness less than 0.006 inch (0.15 mm). Such plates shall be attached by means of nonwater-soluble adhesive which will comply with 2.9. These materials shall not be located on surfaces having temperatures exceeding 300°F (149° C) as determined during the conduct of 2.9.

#### Class IIA-4. Permanent Plate

Shall be made of pressure-sensitive metal foil requiring no solvent or activator, provided such plates comply with 2.9. These materials shall not be located on surfaces having temperatures exceeding 300°F (149° C) as determined during the conduct of 2.9.

#### Class IIIA-1. Permanent Label

Shall be made of materials not adversely affected by water, shall be attached by means of nonwater-soluble adhesive and shall comply with 2.9. These materials shall not be located on surfaces having temperatures exceeding 300°F (149° C) as determined during the conduct of 2.9.

### Class IIIB. Waterproof Marking

Shall be printed directly on the part with waterproof marking not adversely affected by a temperature of 180°F (82.2° C) and shall comply with 2.9. This marking shall not be used on surfaces having temperatures exceeding 180° F (82.2° C) as determined during the conduct of 2.9.

#### Class IV. Nonwaterproof Label

Shall be made of material which may be soluble in water, and may use water-soluble adhesive for attachment means.

#### Class V. Printed Marking

Marking shall be clear and prominent and may be applied directly by any printing means.

#### 1.19.2 Data Plate

Each CNG conversion kit shall contain a data plate of Class IIA-4 material, marked for attachment adjacent to the fill connection so as to be easily read during fill operation.

This plate shall include the following information:

- a. Manufacturer's name and address
- b. Model number
- c. Serial number
- d. Statement "CNG Fueled Vehicle"
- e. System working pressure
- f. Container retest date(s)
- g. Total container water volume in cubic inches

- h. Identification of this requirement with the following marking "A.G.A. Requirement 1-85"
- i. Symbol of the organization making examination for compliance with these requirements
- j. Installer's name and address if different from manufacturer's

#### 1.19.3 Components

- a. Gas carrying operating components shall bear a marking of Class IIA-4 material identifying the manufacturer's name, trademark or symbol, model identification and direction of flow, if required for proper operation.
- b. As appropriate the following information shall be provided:
  1. Working pressure
  2. Electrical ratings
  3. Type of fluid
  4. Identification of testing agency
  5. Identification of standard used for evaluation
  6. Operating temperature range
- c. The provisions of 1.19.3-b may be met by means of a manufacturer's certification enclosed with each lot shipment. Such certification shall be based on testing of random samples selected in accordance with recognized quality control sampling plans acceptable to the certifying agency.

#### 1.19.4 Identification

- a. Each parts package contained within a kit assembly shall be marked to identify the contents and related to the manufacturer's supplied parts list and schematic diagram(s).
- b. Electrical components requiring polarity shall be properly marked.
- c. Containers, if provided, shall bear a Class III-B marking "CNG ONLY" in letters at least 1 inch high and in a contrasting color.
- d. A Class IIIA-1 permanent plate marked "Manual shutoff valve" shall be provided for attachment adjacent to the manual valve between the container manifold and tubing to the engine compartment.

#### 1.20 INSTALLATION INSTRUCTIONS

- 1.20.1 Each kit shall be accompanied by clear, concise printed instructions and diagrams stated in terms clearly understandable and adequate for proper assembly, installation, maintenance and safe operation.
- 1.20.2 Printed instructions shall indicate that prior to use of the vehicle, the installed assembly shall be checked at maximum working pressure for leaks and for normal operation.
- 1.20.3 The instructions shall be marked with directions to the installer to leave them with the vehicle and to the owner to retain them for future reference.
- 1.20.4 The instructions shall contain a statement specifying that any attachment to the container valve relief opening shall maintain at least the same effective cross-sectional area of the opening.

1.20.5 The instructions shall specify that tubing securing devices be placed to minimize vibration of tubing at fittings. If practical, clamping devices should be within 4 inches of such fitting.

1.20.6 Tubing routed within 8 inches of the vehicle battery shall be protected by a durable chemically neutral non-metallic material to prevent corrosive damage due to gasing and to prevent accidental shorting to battery connections.

1.20.7 Solenoid valves shall not be mounted such that they are supported solely by the tubing or hose that they interrupt.

#### 1.21 OPERATING AND MAINTENANCE INSTRUCTIONS

1.21.1 Clear and detailed instructions shall be provided for proper operation of the vehicle, including advice on starting, natural gas operation, switching between gasoline and natural gas fuels, refueling procedures, and emergency procedures in the event of a system malfunction.

1.21.2 Instructions for periodic maintenance of kit components, as required, shall be provided. Parts which require replacement shall be identified.

## PART II

### PERFORMANCE

### Method of Test

#### 2.1 GENERAL

2.1.1 Frequently temperature, pressure and environmental conditions for CNG conversion kits are not within the provisions of referenced standards. If, in the judgment of the testing agency these conditions may adversely affect materials or operating characteristics, applicable provisions of the standards shall be repeated at the extremes of temperature, pressure or environment and shall comply under such conditions with the provisions of the standard.

2.1.2 This part of the A.G.A. Requirements covers performance tests for CNG vehicular conversion kits.

2.1.3 Thermocouples used in making temperature determinations shall be bead type of iron constantan not larger than No. 24 AWG wire.

2.1.4 These requirements evaluate the minimum components and mounting accessories necessary to convert a vehicle to dual fuel or dedicated natural gas operation and compliance of components with applicable published national standards. Performance of the vehicle, when operating on compressed natural gas, depends on the qualifications of the installer, the installation and final tuning.

#### 2 TUBING AND FITTINGS

##### 2.1 Strength

Tubing and fittings shall be capable of withstanding without structural failure or leakage, a hydrostatic pressure equal to four times the specified working pressure.

Representative samples of tubing and fittings shall be assembled in accordance with manufacturer's instructions.

One end of the tubing assembly shall be connected to a hydraulic pressure source and the other end securely capped. Hydraulic pressure shall be applied gradually and uniformly to the sample to a pressure equal to four times the specified working pressure of the CNG system and the pressure maintained for one minute.

There shall be no evidence of leakage at the fittings and no deformation of the tubing.

##### 2.2.3 Reconnection of Fittings

Tubing and fittings shall not leak as a result of being connected, disconnected and reconnected.

##### Method of Test

An assembly such as used for the strength test shall be completely disconnected and then reconnected to the torque specified by the manufacturer. This procedure shall be repeated for a total of three cycles.

The assembly shall then be subjected to strength test as specified in 2.2.1 and observed for any evidence of leakage at the fittings.

##### 2.3 MANUAL VALVES OTHER THAN CYLINDER VALVES

2.3.1 Valves shall be capable of withstanding without structural failure or permanent deformation a test pressure equal to four times the specified working pressure.

##### Method of Test

Representative valves shall be connected to a hydrostatic source.

The outlet shall be securely sealed and the rotor member placed in the open position. Hydrostatic pressure shall be applied gradually and uniformly to the sample to a pressure equal to four times the specified working pressure and maintained for one minute.

There shall be no evidence of structural failure or deformation of the valve components.

This test shall be conducted on three samples and all shall comply.

### 3.2 Leakage

Valves shall not show evidence of leakage when subjected to an air (nitrogen) pressure equal to 1-1/2 times the specified working pressure. The following test shall be conducted at room temperature, -40°F and 250°F, respectively.

#### Method of Test

Five representative valves shall be subjected to this test procedure. Each valve shall be connected to a pneumatic system capable of supplying clean dry air at the test pressure.

With the valve closed and the outlet open, the test sample shall be immersed in a permanent antifreeze solution at the test temperature, and air shall be admitted at low pressure and slowly increased to the test pressure. The test pressure shall be maintained for one minute.

There shall be no evidence of leakage.

The test shall be repeated with the valve open and the outlet sealed.

### 3.3 Continued Operation

Five valves shall be subjected to the following continued operation test of 6000 cycles, half of which will be

at ambient room temperature and half at an ambient of 250°F.

At the end of this test valves shall comply with the provisions of Leakage (2.3.2).

#### Method of Test

Valves shall be securely connected to a suitable pipe fitting and their handles actuated by a connecting rod and crank arrangement to produce approximately 60 cycles per minute. A cycle shall consist of one opening and one closing of the valve.

Valves shall be operated alternately through 1000 cycles at room temperature and 1000 cycles at 250°F until completion of the total number of cycles specified.

During the test, butane gas at 11.0 inch water column shall be passed through the valves at a rate between 0.05 and 0.10 cubic feet per hour.

Following cycling and leakage retest, valves shall be capable of completely opening and closing when a force not greater than the torque specified below is applied to the valve handle in a direction to open it completely and then in the reverse direction.

<u>Valve Size</u>	<u>Max. Torque, in Lbs.</u>
1/4	15
3/8	20
1/2	25

This test shall be conducted at 250°F and shall be repeated at an ambient temperature of -40°F with maximum torque as specified below:

<u>Valve Size</u>	<u>Max. Torque, in Lbs.</u>
1/4	30
3/8	40
1/2	100

## 2.4 CYLINDER MOUNTING HARDWARE

Fuel container(s) and rack when assembled in accordance with the manufacturer's instructions shall be secured in such a manner as to withstand a static force of eight times the weight of the fully pressurized container(s) applied in the six principal directions with a displacement of not more than 1/2 inch.

### Method of Test

Container rack shall be assembled in accordance with manufacturer's instructions and shall be mounted to a test fixture of sufficient rigidity to withstand the applied forces without deformation.

Container(s) shall be mounted in the rack assembly in accordance with instructions and with hardware furnished.

A force equal to eight times the weight of a fully pressurized container(s) shall be applied sequentially in the six principal directions against the centerline of the container(s) which would provide the maximum torque on the mounting means.

This force shall be applied without impact by means of a hydraulic ram or equivalent device through a steel pad having a flat end surface of not less than 7 square inches and shall be maintained for one minute.

Cylinder displacement shall be measured in the same plane as the appliance force vector.

## .5 SEALING SYSTEM

- .5.1 Materials used to isolate high pressure container(s) and manifold leakage from enclosed vehicle compartments shall show no evidence of deterioration at temperatures of -40° F and 180° F.

### Method of Test

Two samples of the sealing material shall be secured to clean bare carbon steel plates using the adhesive specified by the manufacturer. These test fixtures shall be allowed to set at room temperature for 24 hours, after which both samples shall be placed in a test chamber maintained at an ambient temperature of -40° F for 48 hours.

While maintained at -40° F, one sample shall be flexed and examined for evidence of cracking, embrittlement or other deterioration of either the material or adhesive.

The second sample shall be placed in a test chamber maintained at an ambient temperature of 180° F for 48 hours.

Upon removal from the test chamber, the sample shall be examined for evidence of cracking, embrittlement or other deterioration of either the material or adhesive.

- 2.5.2 Sealing materials used in this application shall not support combustion.

- 2.5.3 The Method of Test under 2.5.1 shall be repeated with two additional samples subjected to an ambient temperature of 180° F followed by an ambient temperature of -40° F.

Sealing materials and adhesive shall not be adversely affected by natural gas.

### Method of Test

A sample of the sealing material shall be secured to a clean bare carbon steel plate using the adhesive specified by the manufacturer and allowed to set at room temperature for 24 hours. The sample shall then be immersed in n-hexane for 70 hours, after which it will be examined for adverse effects on the material and the adhesion qualities of the adhesive.

## 2.6 REGULATORS AND REGULATOR SYSTEMS

2.6.1 Regulators shall comply with the performance provisions of UL 252 and, in addition, shall comply with the following provisions:

- (a) Seat and external leakage test, as specified in UL 252, shall be conducted at a test pressure of one and one-half times the specified working pressure and at an ambient temperature range of -40°F and 250°F.
- (b) Regulator bodies shall be capable of withstanding without structural failure or permanent deformation a test pressure equal to four times the specified chamber working pressure. See also 1.13.2

### Method of Test

The high and low pressure sides of the regulator shall be connected to independent hydrostatic pressure sources. Pressure shall be applied to both inlet and outlet gradually and uniformly to a pressure equal to four times the specified working pressure in each chamber and maintained for one minute.

There shall be no evidence of structural failure, including sealing means to atmosphere or deformation of the regulator body.

2.6.2 The regulator system shall exhibit uniform regulating characteristics and lock up pressure characteristics when tested as outlined in 2.6.3, 2.6.4 and 2.6.5.

These tests shall be conducted prior to the endurance test.

### Test Equipment and Setup

The inlet to the regulator system shall be connected to a source of gas, nitrogen, or air capable of developing the manufacturer's specified working pressure.

The outlet of the system shall be equipped with a quick opening and closing valve and a flow adjustment device(s) capable of permitting the manufacturer's specified maximum and minimum gas flow through the system.

Means to measure system inlet pressure and the outlet pressures from each regulating device in the system shall be installed.

2.6.3 Measurement of inlet and outlet pressures at each regulating device and of flow through the regulator system shall be recorded under the following conditions of temperature and system inlet pressure.

- a) Test condition 1: Manufacturer's specified working pressure and ambient temperature of 250°F
- b) Test condition 2: Inlet pressure of 100 psig and ambient temperature of 250°F
- c) Test condition 3: Manufacturer's specified working pressure and ambient and test gas temperature of -40°F
- d) Test condition 4: Inlet pressure of 100 psig and ambient and test gas temperature of -40°F.

### Method of Test

The manufacturer's specified maximum flow shall be established and recorded at an inlet pressure to the system at 50 percent of the specified working pressure and at an ambient temperature of 77°F ± 10°F. The inlet and outlet pressure at each regulating device shall be measured and recorded.

With no further flow adjustment, test conditions 1, 2, 3 and 4 shall be established sequentially. Inlet and



outlet pressures at each regulating device and system flow shall be measured and recorded for each test condition.

The system flow determined under test conditions 1, 2, 3 and 4 shall not vary by more than  $\pm 10$  percent from the initial adjustment.

The outlet pressure of each regulating device, as determined under test conditions 1, 2, 3 and 4, shall not exceed the rated inlet pressure of the next downstream regulating device.

- 2.6.4 The test conditions and Method of Test prescribed in 2.6.3 shall apply when the initial flow adjustment is established at the manufacturer's specified minimum flow and with a system inlet pressure of 50 percent of the specified working pressure at an ambient temperature of  $77^{\circ}\text{F} \pm 10^{\circ}\text{F}$ .

The system flow determined under test conditions 1, 2, 3 and 4 shall not vary by more than  $\pm 10$  percent from the initial adjustment. The outlet pressure of each regulating device, as determined under test conditions 1, 2, 3 and 4, shall not exceed the noted inlet pressure of the next downstream regulating device.

- 2.6.5 Lock up pressure of each regulating device shall be determined under test conditions 1, 2, 3 and 4 (2.6.3) and initial adjustments (2.6.3 and 2.6.4).

#### Method of Test

Gas flow shall be interrupted by operation of the quick opening and closing valve under each test condition prescribed for maximum flow and minimum flow.

Outlet pressures from each regulating device shall not exceed the rated inlet pressure of the next downstream regulating device.

- 2.6.6 The regulator system shall withstand 100,000 cycles of operation without change in regulating characteristics or lock up pressure characteristics when tested as outlined below:

#### Method of Test

Test set up shall be as specified in 2.6.2.

The regulator system flow shall be in accordance with 2.6.3, initial adjustment, and shall be cycled 50,000 cycles at the manufacturer's specified working pressure at an ambient temperature of  $250^{\circ}\text{F}$ .

Each cycle shall consist of flow until stable outlet pressure downstream of each regulating device in the regulating system has been obtained, after which the gas flow shall be shut off by the downstream quick closing valve until the lock up pressure downstream of each regulating device has stabilized.

At the completion of 50,000 cycles, the system flow rate shall be within  $\pm 10$  percent of the flow measured in 2.6.3, initial adjustment, and the lock up pressure downstream of each regulating device in the regulator system shall not exceed the rated inlet pressure of the next downstream regulating device.

The regulator system shall be cycled an additional 50,000 cycles at an ambient and test gas temperature of  $-40^{\circ}\text{F}$  and otherwise as specified above.

At the completion of the additional 50,000 cycles, system flow rate shall be within  $\pm 10$  percent of the flow measured in 2.6.3, initial adjustment, and the lock up pressure downstream of each regulating device in the regulator system shall not exceed the rated inlet pressure of the next downstream regulating device.

2.6.7 Provision shall be made to protect regulating components downstream of the first stage regulator from damage or malfunction due to overpressure.

## 2.7 GAS AIR MIXERS

### Continued Operation

2.7.1 Gas air mixers containing movable components for fuel selection shall be subjected to 6000 cycles of continued operation in accordance with the following Method of Test. There shall be no evidence of deterioration which would adversely affect its intended operation.

#### Method of Test

A gas air mixer assembly shall be installed in a test fixture which will cause the mixer to operate in accordance with its designed function.

Gas air mixers shall be operated alternately through 1000 cycles at -40° F and 1000 cycles at 250° F until completion of the total number of cycles specified.

For purposes of this test, a cycle is defined as movement from one operating position to the other operating position. Rate of cycling shall not be more rapid than six movements per minute.

2.7.2 Gas air mixers containing movable components which control fuel flow shall be subjected to 100,000 cycles of continued operation in accordance with the following Method of Test. There shall be no evidence of deterioration which would adversely affect its intended operation.

#### Method of Test

A gas air mixer assembly shall be installed in a test fixture which will cause the mixer to operate in accordance with its designed function.

Gas air mixers shall be operated alternately through 10,000 cycles at -40°F and 10,000 cycles at 250°F until completion of the total number of cycles specified.

For purposes of this test, a cycle is defined as movement from one operating extreme to the other operating extreme and return. Rate of cycling shall not be more rapid than 20 movements per minute.

## 2.8 GAGE ISOLATOR

2.8.1 Gage isolators shall be capable of withstanding without structural failure permanent deformation or leakage at seams or joints a test pressure equal to four times the specified working pressure.

#### Method of Test

A representative isolator shall be connected to a hydrostatic pressure source. The outlet shall be securely sealed.

Hydrostatic pressure shall be applied gradually and uniformly to a pressure equal to four times the specified working pressure and maintained for one minute.

There shall be no evidence of structural failure, deformation or leakage at seams or joints of the isolator.

2.8.2 Gage isolators shall permit the transfer of system working pressure to the fuel gage.

#### Method of Test

Gage isolator inlet shall be connected to a pneumatic source capable of providing the system working pressure. The outlet shall be connected to the fuel gage provided by the manufacturer through tubing and fittings supplied with the kit. If specified, the tubing shall be filled in accordance with the manufacturer's

instructions. Pressure shall be admitted and slowly increased to the system working pressure. The gage shall be observed during this test to determine that it responds to increasing pressure.

The outlet pressure shall then be gradually decreased and the gage observed for response to decreasing pressure.

This test shall be conducted at temperatures of  $-40^{\circ}$  F and  $250^{\circ}$  F.

- 2.8.3 The gage isolator shall act to prevent system pressure from entering the passenger compartment in the event of a rupture in the gage or tubing assembly.

#### Method of Test

The gage isolator inlet shall be connected to a pneumatic source capable of providing the system working pressure. The outlet shall be connected to the fuel gage provided by the manufacturer through tubing and fittings supplied with the kit. A tee fitting shall be inserted in the tubing line with the second outlet connected by tubing to a normally closed full bore electric solenoid valve designed to hold system working pressure.

If specified the tubing shall be filled in accordance with the manufacturer's instructions. Pressure shall be admitted and slowly increased to the system working pressure. Pressure shall be maintained until it stabilizes. With the system pressure maintained the solenoid valve shall be energized to the open position. There shall be no evidence of leakage past the isolator.

## 2.9 MARKING MATERIAL ADHESION AND LEGIBILITY

- 2.9.1 The adhesive quality of Class IIA-3, IIA-4 and IIIA-1 marking materials and the legibility of Class II,

IIIA and IIIB marking materials shall not be adversely affected when the marking materials are exposed to heat and moisture as specified in the following Method of Test.

#### Method of Test

- a. Adhesive type marking materials shall be applied to a metal panel finished with automotive type paint. A sample metal panel of this finish shall be cleaned with a solvent and dried. Half of the panel shall be wiped with a clean cloth lightly oiled with SAE-30 medium machine oil. Two samples of marking material shall be applied to the panel, one on the dry area and one on the oiled area. Test samples shall be applied with firm pressure, unless the manufacturer's application instructions specify otherwise. Each sample shall be allowed to set for 24 hours at room temperature. Each sample of marking material shall exhibit:
1. Good adhesion and no curling at edges.
  2. No illegible or defaced printing by rubbing with thumb or finger pressure, and
  3. Good adhesion when a dull metal blade (such as the back of a pocketknife blade) is held at right angles to the applied marking and scraped across the edges of the marking.
- b. Nonadhesive type marking material shall exhibit no illegible or defaced printing when rubbed with thumb or finger pressure. Two samples of marking material shall be tested.
- c. Samples of both adhesive and nonadhesive type marking materials shall then be placed in an oven for a period of 2 weeks with the oven temperature maintained at:

1. 350° F (176.5° C) for Class IIA-1, IIA-2, IIA-3, IIA-4 and IIIA-1 marking materials, or
2. 250° F (121° C) for Class IIB marking materials.

Following the oven test, adhesion and legibility of the samples shall be checked again as specified in "a" or "b" above.

Samples shall then be immersed in water for a period of 24 hours, after which adhesion and legibility shall be rechecked as specified in "a" or "b" above.

Good adhesion and legibility qualities shall be obtained for all samples under the above specified test conditions.

Final acceptance of marking materials shall be based on the suitability of the application of the marking material to the component.