

2

DTIC

LECTURE

MAY 24 1991

AFOTECP 400-1

AD-A235 987



AIR FORCE OPERATIONAL TEST AND EVALUATION CENTER

PAMPHLET



Accession For	
DTIC GRA&I	<input checked="" type="checkbox"/>
DTIC I&S	<input type="checkbox"/>
Unannounced	<input type="checkbox"/>
Justification	
By	
Distribution/	
Availability Codes	
Disc	Avail and/or Special
A-1	



OPERATIONAL SUITABILITY TEST AND EVALUATION

15 MAY 1991

DEPARTMENT OF THE AIR FORCE

AIR FORCE OPERATIONAL TEST AND EVALUATION CENTER

91 5 23 047

91-00440



15 May 1991

Recurring

Operational Suitability Test and Evaluation

David B. Young

Air Force Operational Test and Evaluation Center

Kirtland AFB NM 87117-7001

AFOTEC/PAM--400-1

Supercedes edition of 29 February 1984

Distribution Unlimited

Provides logistics personnel with a base on which to build knowledge of concepts and procedures pertaining to operational suitability test and evaluation. Key activities discussed include test concept development, operational assessments, test execution, and test reporting. In addition, key operational suitability evaluation areas (availability, reliability, maintainability, etc.) are discussed in detail with lessons learned provided. The document is intended to serve as a guide for personnel/agencies involved in operational test and evaluation (OT&E).

operational suitability, test and evaluation,
logistics, operational test and evaluation, availability,
reliability, maintainability, software evaluation, integrated
diagnostics, supportability

155

Unclass.

Unclass.

Unclass.

UL

15 May 1991

FOREWORD

1. AFOTEC Pamphlet 400-1 provides logistics personnel with a base on which to build knowledge of concepts and procedures pertaining to operational suitability test and evaluation. It is intended to serve as a "how to" guide for HQ AFOTEC/LG staff, AFOTEC detachments and test teams and other agencies involved in operational test and evaluation (OT&E) may also find it useful. The pamphlet is divided into three parts as follows:

a. Part I gives an overview of the pamphlet and operational suitability test and evaluation.

b. Part II deals with the key activities of operational suitability test and evaluation, i.e., test concept development, operational assessments, test execution, and test reporting. Included is a discussion of participating organizations and their relationships.

c. Part III provides detailed discussions on key operational suitability evaluation areas, i.e., availability, reliability, maintainability, software evaluation, and integrated diagnostics. Attachments provide additional discussions of special operational suitability areas/issues such as dormant reliability, nuclear hardness maintenance/hardness surveillance (FIM/HS), and considerations of availability evaluations by system type.

2. Most of the chapters include a discussion of lessons learned relative to the chapter topic. These lessons are not meant to be all inclusive. The dynamics of the OT&E business will constantly require judgment on the part of operational suitability/logistics personnel when applying these lessons to their assigned program/mission.

3. As a final note, we realize that publication of this pamphlet precedes several key Air Force regulations (AFR) (AFR 57-1 and 800 series). This impact is reduced if the following points are kept in mind:

a. The cost and operational effectiveness analysis (COEA) is a new key acquisition document. Experience with it will be incorporated in future updates to this pamphlet. Also experience with the evolutionary requirements process, exit criteria, and system maturity matrices is not covered in this issuance of the pamphlet.

b. A new procedural guide to replace LGOI 400-1, Qualitative Maintainability and Logistics Supportability Questionnaires, is planned.

c. Results from AFOTEC general support contract studies on integrated diagnostics are not complete and so are not included in the chapter on integrated diagnostics.

4. Requests for copies of, changes to, or questions concerning this document should be made to:

HQ AFOTEC/LG3.
Kirtland AFB, New Mexico 87117-7001

	Paragraph	Page
PART I—Overview		
Chapter 1—Introduction		
Objectives	1-1	1-1
Organization	1-2	1-1
Principal Sources of System Information	1-3	1-1
Chapter 2—Operational Suitability Test and Evaluation		
Rationale for Conducting Operational Suitability OT&E	2-1	2-1
Suitability Test and Evaluation	2-2	2-1
System Operating Phase Analysis	2-3	2-1
Constraints on Operational Suitability Testing	2-4	2-1
Lessons Learned	2-5	2-1
USAF OT&E Lessons Learned Program	2-6	2-1
Chapter 3—Considerations for Operational Suitability		
Introduction	3-1	3-1
Qualitative Maintainability	3-2	3-1
Logistics Supportability	3-3	3-1
Support Equipment (SE)	3-4	3-2
Supply Support	3-5	3-3
Technical Data	3-6	3-4
Packaging Handling, and Transportation (PHT)	3-7	3-5
Maintenance Facilities	3-8	3-6
Maintenance Training	3-9	3-6
Maintenance Planning	3-10	3-7
Other Considerations	3-11	3-8
PART II—Key Operational Suitability Activities		
Chapter 4—Preparing for Test Planning Reviews (TPR)		
General	4-1	4-1
Test Concept Approval	4-2	4-1
Updating the Test Concept	4-3	4-5
Draft Test Plan (with DMAP)	4-4	4-5
TPR Example	4-5	4-5
Lessons Learned	4-6	4-5
Chapter 5—Preparing for Operational Assessments (OA)		
General	5-1	5-1
Milestone I OAs	5-2	5-1
Milestone II OAs	5-3	5-2
Milestone IIIA OAs	5-4	5-3
Sample Operational Assessment	5-5	5-3
Lessons Learned	5-6	5-4
Chapter 6—Preparing for Test Execution		
General	6-1	6-1
Participating Organizations	6-2	6-1
Roles of Test Participants	6-3	6-1
Activating the Test Team	6-4	6-3
Review of Program Documentation	6-5	6-4

	Paragraph	Page
Key Meetings	6-6	6-5
Active Testing	6-7	6-5
Service Reporting (SR)	6-8	6-5
Lessons Learned	6-9	6-5
Chapter 7—Managing Operational Suitability Data		
General	7-1	7-1
Data Management and Analysis Plan (DMAP)	7-2	7-1
Air Force Data Systems	7-3	7-2
Other Data Sources	7-4	7-4
Logistics Support Analysis Program	7-5	7-5
Combining DT&E and OT&E Data	7-6	7-7
Joint Reliability and Maintainability Evaluation Team	7-7	7-7
Lessons Learned	7-8	7-8
Chapter 8—Developing Operational Suitability Reports		
General	8-1	8-1
Operational Suitability Reports	8-2	8-1
Report Considerations	8-3	8-2
Lessons Learned	8-4	8-3
PART III—Key Operational Suitability Evaluation Areas		
Chapter 9—Availability		
General	9-1	9-1
Availability Requirements	9-2	9-1
"Real" Versus "Apparent" Availability	9-3	9-3
Definitions	9-4	9-3
Mathematical Expressions of Availability	9-5	9-4
A General Approach for Evaluating Availability	9-6	9-6
Recovery Time Considerations in System Availability	9-7	9-6
Availability for Multimission Systems	9-8	9-6
Data Analysis	9-9	9-8
Availability Simulation/Modeling	9-10	9-8
Lessons Learned	9-11	9-12
Key References for Availability	9-12	9-12
Chapter 10—Reliability		
General	10-1	10-1
Reliability Requirements	10-2	10-1
Definitions and Concepts	10-3	10-1
R&M Policy Guidance	10-4	10-3
System Reliability Design Objectives	10-5	10-4
System Reliability Models	10-6	10-5
Statistical Test Design	10-7	10-6
The Need for Projection Capability During OT&E-Background	10-8	10-8
Application of Projections	10-9	10-9
Reliability Growth and Tests	10-10	10-9
Reliability Evaluation	10-11	10-12
Lessons Learned	10-12	10-12
Chapter 11—Maintainability		
General	11-1	11-1
Definitions and Concepts	11-2	11-1
Policy	11-3	11-1
Considerations in Planning Maintainability Assessment	11-4	11-2
Maintainability Indices	11-5	11-2
Integrated Diagnostics	11-6	11-4
Maintainability Growth	11-7	11-4

	Paragraph	Page
Tracking Maintainability Growth	11-8	11-4
Data Analysis	11-9	11-4
Maintainability Demonstrations (M-Demos)	11-10	11-5
Lessons Learned	11-11	11-6
Chapter 12—Software Evaluation		
Introduction	12-1	12-1
Software Maturity Evaluation	12-2	12-1
Software Usability Evaluation	12-3	12-2
Software Supportability	12-4	12-2
Other Software Evaluation Methods	12-5	12-6
Software Evaluation Reporting	12-6	12-7
Chapter 13—Integrated Diagnostics		
Introduction	13-1	13-1
Planning the Evaluation	13-2	13-4
Conducting the Evaluation and Reporting the Results	13-3	13-11
Figures		
2-1. Areas of Operational Suitability		2-2
4-1. OT&E Planning Process		4-2
4-2. Hierarchy of Test Concept Elements		4-4
6-1. OT&E Program Management Relationships		6-2
7-1. LSA Inputs and Outputs		7-6
7-2. Typical JRMET Organization		7-9
9-1. System Operational Requirements		9-2
9-2. Mission Availability Time Line Model (General Format)		9-7
9-3. Operational Availability Time Line Model		9-7
9-4. Mission Availability Time Line Model (Recovery Time Format)		9-8
9-5. Factors to Include in Availability Modeling		9-10
9-6. F-15E SLAM Flow		9-11
10-1. Example of a Planned Growth Curve and Corresponding Idealized Curve		10-12
12-1. Software Maturity Concept		12-3
12-2. Software Maturity (Final Report)		12-4
13-1. Repair Process		13-2
13-2. Contractor Data Needed for Diagnostics Evaluation Planning		13-6
13-3. Integrated Diagnostics Measures and Factors		13-12
13-4. Example of table for Presenting Diagnostics Results		13-14
13-5. Example of Table for Presenting Troubleshooting Results		13-15
Attachments		
1. Nuclear Hardness Maintenance/Hardness Surveillance (HM/HS)		A1-1
2. Dormant Reliability		A2-1
3. Availability in Aircraft, Avionics, Simulators, Ground Communication/ Weather Systems, and Munitions		A3-1
4. Space Systems Assessment		A4-1
5. Reference Documentation		A5-1
6. Definitions		A6-1
7. Abbreviations		A7-1
8. Data Item Description		A8-1

Part I

OVERVIEW

Chapter 1

INTRODUCTION

1-1. Objectives:

a. AFOTECP 400-1 is a guide for planning, executing, and reporting an Air Force operational suitability test and evaluation (T&E).

b. Some uses of the pamphlet are:

(1) A training aid for logistics personnel unfamiliar with concepts and procedures concerning operational suitability test and evaluation.

(2) A guide for AFOTEC logistics staff in preparing and evaluating test plans and data management and analysis plans (DMAP).

(3) A guide for operating command personnel preparing operational suitability portion of test plans.

(4) A guide for test team personnel executing and reporting operational suitability test and evaluation.

1-2. Organization:

a. AFOTECP 400-1 provides logistics and software evaluation managers, analysts, and test team members with "how to" information helpful in planning, executing, and reporting operational suitability evaluations of systems. Part one contains an overview of the operational suitability T&E process.

b. Part two focuses on how operational suitability T&E is planned and executed. The description of test planning progresses from general to specific cases, and the discussion of test execution progresses from prepa-

ration through reporting.

c. Part three examines key operational suitability areas and the relationship between the three basic quantitative system parameters availability, reliability, and maintainability. Simulation models available to assist in extending test results are identified and briefly described.

d. The attachments expand on specific areas/issues of operational suitability test and evaluation such as document reliability, nuclear HM/HS, and availability evaluation of specific systems.

1-3. Principal Sources of System Information.

The ability to perform an operational test and evaluation (OT&E) which is responsive to program decision needs is dependent on the availability of system-specific information. Much of the information is available from the implementing and using commands and DOD. For major systems, a series of documents provide this information as described in attachment 5. Use of these documents in test planning and execution is explained in part two. In addition, major programs should have additional documentation such as a Program Management Plan (PMP), Reliability and Maintainability Management Plan (RMMP), and a Life Cycle Cost Management Plan. Less-than-major systems generally have fewer documents available.

Chapter 2

OPERATIONAL SUITABILITY TEST AND EVALUATION

2-1. Rationale for Conducting Operational Suitability OT&E. The objective of operational suitability test and evaluation is to ensure that emerging systems can be operated and maintained in field conditions. Operational suitability test and evaluation often results in changes in system design which result in improved availability and significant savings in spares, fuel, manpower, and other scarce logistics resources.

2-2. Suitability Test and Evaluation. Operational suitability is the degree to which a system can be satisfactorily placed in field use, with consideration given to availability, compatibility, transportability, interoperability, reliability, wartime usage rates, maintainability, safety, human factors, manpower supportability, logistics supportability, and training requirements. While logistics personnel are generally responsible for the operational suitability evaluation, the division of responsibility for several of the suitability areas (or elements) defined above is not clear. For example, safety, human factors, compatibility, and interoperability apply to both operational suitability and operational effectiveness. These areas may be addressed under suitability and effectiveness, by neither, or by one or the other dependent on the unique aspects of the system being evaluated. Figure 2-1 portrays the relationship among the areas of operational suitability. Every suitability test and evaluation should:

- a. Measure the hardware and software suitability performance of the system.
- b. Document and track deficiencies and proposed enhancements using a service reporting system.
- c. Evaluate corrective actions for identified deficiencies to ensure they adequately resolve the original problem without causing new problems.
- d. Estimate the mature operational suitability of the system, primarily through modeling and simulation.
- e. Compare the estimated mature performance with the user requirements.

2-3. System Operating Phase Analysis. Most systems of interest are designed to operate in three distinct phases: peacetime operations, increased readiness postures, and actual wartime mission execution. The system operational requirements for each of these phases may be different, as are the

primary measures of system suitability performance. The environment during OT&E comes closest to emulating the peacetime-phase but, because of the many constraints involved, is often not truly representative of even peacetime operational conditions.

2-4. Constraints on Operational Suitability Testing:

a. Operational suitability test and evaluation is conducted throughout the acquisition process. During the earliest stages of a system's evolution, it is obvious any evaluation must be accomplished without the benefit of the system—it has not yet left the drawing boards. Operational suitability tests are frequently conducted with the following limitations: limited test assets, prototype equipment, and immature or nonexistent logistics elements such as technical orders, supply support, and support equipment.

b. An obvious limitation is the inability to test the system in a wartime environment. A primary operational test objective is to execute the test in as realistic an environment as possible. In some instances, the system is deployed to a potential operational site for testing. However, considerations such as test schedule, funds limitations, and system immaturity often preclude testing at other than a test range. Consequently, system analysis modeling is frequently used. Models provide the capability to tackle issues such as a system's logistics characteristics during war, to give significance and utility to test results beyond the narrow conditions of the test, and to develop a reasonably accurate measure of the system's availability and mission reliability. Modeling techniques are discussed in part three of this pamphlet.

2-5. Lessons Learned. Lessons learned from past OT&E programs are a valuable source of information for planning and executing suitability assessments. Most chapters of this pamphlet conclude with a discussion of lessons learned.

2-6. USAF OT&E Lessons Learned Program. The objective of the formal OT&E lessons learned program, administered by HQ AFOTTEC/XPX, is to ensure future efforts benefit from past experience. Lessons learned reports which document technical, management, and operations security (OPSEC) are contained in the lessons learned file of

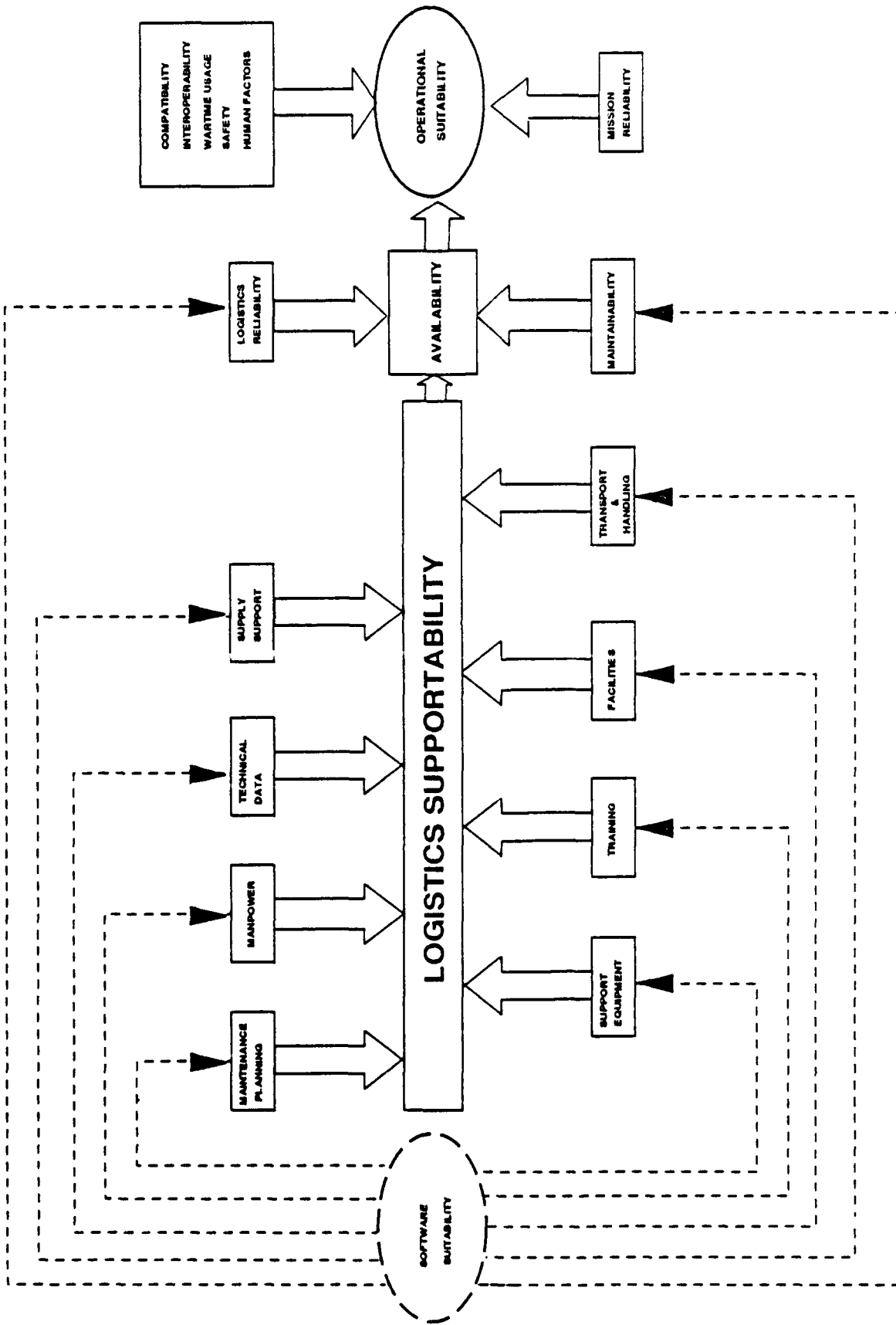

Figure 2-1. Areas of Operational Suitability

the USAF OT&E data bank. (For more information, refer to AFR 55-43 and AFOTECR

800-1, OT&E Lessons Learned Program.)

Chapter 3

CONSIDERATIONS FOR OPERATIONAL SUITABILITY

3-1. Introduction. This chapter outlines the common (and generally qualitative) considerations of operational suitability and examines some factors that most commonly affect these considerations. Chapter 3 should be used to supplement chapter 7 and part three. The following considerations are addressed herein:

- a. Qualitative maintainability.
- b. Logistics supportability.
- c. Support equipment.
- d. Supply provisioning.
- e. Technical data.
- f. Packaging, handling, and transportation.
- g. Facilities.
- h. Maintenance training.
- i. Maintenance planning.
- j. Software.
- k. Other considerations.

Questionnaires used in the assessment of some of these areas can be found in LGOI 400-1, Qualitative Maintainability and Logistics Supportability Questionnaires.

3-2. Qualitative Maintainability:

a. Maintenance Actions. The planner should consider qualitative maintainability (i.e., accessibility, serviceability, ease or difficulty of maintenance, safety, and human factors) associated with maintenance actions, as well as quantitative aspects of maintainability. General considerations include:

- (1) Are the components easily removed?
- (2) What effect will adverse environmental conditions such as cold weather or CBW have on the technicians' ability to perform maintenance tasks?
- (3) Since maintainability is also concerned with servicing, inspecting, troubleshooting, repairing, removal, and replacement tasks, at what level (e.g., flight line, shop, depot) can specific maintenance actions be accomplished?

b. Maintainability Assessment. Answers to these questions will affect the quantity, skill level, and specialty code of personnel and the test equipment required to maintain a system. The importance of this assessment cannot be overemphasized. Historically, over 50 percent of the OT&E service reports result from qualitative maintainability assessment.

c. Test Methodology. Experienced maintenance technicians should conduct the qualitative assessment of maintainability.

AFOTTEC has developed a procedural guide (LGOI) which contains a general checklist for such an assessment. The checklist is designed to be modified by headquarters and test team personnel based on specific program requirements.

d. Data Requirements. An assessment form or questionnaire will normally be used to gather data for the qualitative assessment. These data are often used as supporting data for the quantitative measures. Where feasible, use of video recording equipment should also be considered to gather information for both qualitative and quantitative assessments and evaluations.

e. Assessment. For the qualitative assessment of maintainability, subjective judgments will normally be used. However, these judgments can often be supported with the quantitative tools discussed under the reliability and maintainability evaluations. The following are general points to be considered:

- (1) Time-consuming tasks which affect turnaround times or downtime.
- (2) Tasks for which a special tool will solve a maintainability problem.
- (3) Scope and frequency of inspections in areas with poor accessibility or location.
- (4) Human factors considerations (e.g., weight, handles, height above ground level, etc.).
- (5) Effects of climatic extremes on the ability of maintenance personnel to perform tasks.
- (6) Ease of removal, replacement, repair, fault isolation, inspecting, lubrication, and servicing of the weapon system.
- (7) Minimum crew size requirements, when applicable.
- (8) Special handling and protective equipment (particularly chemical, biological, and radiological (CBR)).
- (9) Provisions for nondestructive inspections.
- (10) Provisions for crash recovery.
- (11) Unsatisfactory or unsafe maintenance procedures dictated or promoted by component, hardware, or installation design.

3-3. Logistics Supportability. Logistics supportability assessment addresses the various elements of integrated logistics support (ILS), e.g., technical data, facilities, and maintenance training. The ability to assess ILS elements depends on the test environ-

ment. For example during IOT&E, support equipment and technical data may not be available or representative of the operational items. Further, the contractor typically provides supply support. Test plans should be written to give the test team latitude to document any logistics supportability observations they may be able to make within the constraints of the test.

3-4. Support Equipment (SE). For OT&E purposes, SE can be divided into two classes—major and nonmajor. In reality, which kind of evaluation to perform on a given piece of SE will not be an either/or decision but will be a matter of degree. The planner should consider such factors as unit cost, degree of risk, projected utilization rates, maintenance requirements, and complexity in determining the extent of evaluation required. Major equipment usually includes such items as avionics systems automatic test stations, newly designed complex SE, and similar equipment. Nonmajor equipment usually includes such items as nonpowered SE, hand tools, and SE that is already in the inventory. The selection of measures of effectiveness (MOE) will depend on the complexity of the equipment and its function. Normally, only a few major types of equipment, such as avionics test stations, will have quantitative requirements listed in the maintenance concept or other program documentation. For these types of SE, comprehensive reliability, maintainability, availability, and logistics supportability evaluations/assessments should be conducted and the MOEs selected accordingly.

a. General Considerations. Factors to be considered in developing SE objectives and MOEs are:

- (1) Reliability.
- (2) Maintainability.
- (3) Availability.
- (4) Suitability for mobility, deployment, and base operations, as appropriate.
- (5) Ease or difficulty of operation.
- (6) Effectiveness in performing troubleshooting and diagnostic functions.
- (7) Requirements for test, measurement, and diagnostic equipment (TMDE) support.
- (8) Human factors, such as operator-machine interface, ease of handling, weight and size of components, etc.
- (9) Susceptibility to damage, contamination, or corrosion.
- (10) Quantity of units needed versus authorized.
- (11) Other ILS elements' capability to support the SE (that is, technical data,

supply support, facilities, etc.).

(12) Safety.

(13) Compatibility.

b. Test Methodology. For major SE, a comprehensive test methodology which is nearly as detailed as that used for the prime system may be required.

c. Data Requirements:

(1) SE may have one or more of the following techniques applied, depending on type and complexity of the equipment:

(a) Data collection (automated or manual) either using maintenance data collection system (MDCS), system effectiveness data system (SEDS), or a system patterned after them to record data and make basic MOE computations.

(b) A detailed log book on the SE in which predetermined significant data are recorded for a specified period of time.

(c) Realistic reliability and maintainability (R&M) demonstrations during which significant predetermined data are recorded.

(d) Predetermined data on an evaluation form/questionnaire each time the equipment is used or maintained.

(2) For comprehensive evaluations, use of standard MDCS or SEDS is desirable. If a contractor data system must be used, it should approximate the Air Force systems as closely as practical. Over-the-shoulder data collection or having the contractor fill out Air Force forms and then processing them at an Air Force facility are alternatives which should be explored thoroughly before becoming dependent on contractor data.

(3) Data collection using log books or test team-developed forms will require manual processing and analysis.

(4) References:

(a) AFR 66-1, Maintenance Management Policy.

(b) AFR 66-14, The US Air Force Equipment Maintenance Program.

(c) AFM 67-1, Basic Air Force Supply Procedures.

(d) AFLCR 67-2, USAF Equipment Allowance System.

(e) AFR 800-12, Acquisition of Support Equipment.

c. Evaluation. Identify SE deficiencies and areas requiring enhancement or optimization. Such an evaluation will normally include a combination of quantitative and qualitative techniques.

d. Evaluation Criteria. Evaluation criteria will normally only be developed for those MOEs for which operational requirements are stated in the program documentation.

3-5. Supply Support:

a. Operational Readiness. Maintaining operational readiness under diverse conditions of military use depends directly on the right supplies being available at the time and place they are needed. During an OT&E, supply support objectives can be divided into five basic categories:

(1) Providing consumption, failure, and other test data to the provisioner in order to update provisioning factors.

(2) Comparing test data with the provisioning factors to identify items which appear to be underprovisioned or overprovisioned.

(3) Reviewing initial spares support lists (ISSL), bench stock, war readiness spares kit (WRSK), or mission support kit (MSK) listings and comparing them with test results to identify items which appear to be under or in excess of expected requirements.

(4) Measuring the performance of the supply support system and identifying deficient areas.

(5) Reviewing level of repair decisions.

b. OT&E Supply Support. Frequently, a contractor provides OT&E supply support. Review supply planning decisions to compare them with test experience to date. This is an ongoing process and should continue throughout OT&E. When a test site is located at an operational location and contractor support has ended, standard Air Force supply support may begin. Requisition fill rates, partially mission capable supply (PMCS), not mission capable supply (NMCS) rates, and other supply indices may be measured. The prime supply MOEs are those that affect the availability of the weapon system (e.g., NMCS rates).

c. General Considerations. The planner should consider the following factors in developing supply support objectives and MOEs:

(1) Component reliability.

(2) Component criticality.

(3) Effects of supply support on availability (partially mission capable, both (maintenance and supply) (PMCB) and not mission capable, both (maintenance and supply) (NMCB)).

(4) Not repairable this station (NRTS) rates and their causes.

(5) Condemnation rates.

(6) Bench check serviceable rates and causes.

(7) Cannot duplicate (CND) rates and causes.

(8) Cannibalization rates.

(9) Mean time between demands (MTBD).

(10) ISSL, WRSK, MSK, and bench stock listing adequacy.

(11) Delayed repair of components awaiting parts.

(12) Average component repair days (indicates the average number of days it takes to repair an item, excluding time awaiting parts).

(13) Inadequacies in technical data or SE which impact supply support.

(14) Source, maintenance, and recoverability (SMR) coding.

d. Test Methodology:

(1) Select the more critical supply items for evaluation. The planner should consider factors such as complexity, cost, criticality, and failure rates in selecting these candidates.

(2) To evaluate the adequacy of the total provisioning process, a predetermined number of components can be selected randomly and evaluated. These data can then be statistically treated to make conclusions about the adequacy of the provisioning process for the population as a whole.

e. Data Requirements:

(1) The reliability and availability objectives plus the data from the provisioning agency and from the supply tracking system being used for the test normally satisfy the data requirements. If the data for this requirement must come from the contractor, test planner must ensure the data item descriptions (DID) from which the data are obtained are included in the full-scale development (FSD) contract.

(2) Other required data will include such items as the ISSL, WRSK, MSK, and bench stock listings and logistics support analysis records (LSAR). The provisioning activity or the prime Air Logistics Center (ALC) normally develops and provides these data.

(3) References:

(a) AFR 55-43, Management of Operational Test and Evaluation.

(b) AFR 65-110, Aerospace Vehicle and Equipment Inventory, Status, and Utilization Reporting System (AVISURS).

(c) AFR 66-1, Maintenance Management Policy.

(d) AFR 66-45, Joint Regulation Governing the Use and Application of Uniform Source, Maintenance, and Recoverability Codes.

(e) AFM 67-1, Basic Air Force Supply Procedures.

(f) MIL-STD 1388, Logistics Support Analysis.

f. Evaluation. Normally the evaluation of supply support should include:

(1) Measuring key supply parameters and evaluating them against criteria, when stated in the user requirement document.

(2) Estimating the supply system's ability to support the system at required levels.

(3) Identifying the components that are underprovisioned.

(4) Reviewing and assessing the adequacy of the WRSK, ISSL, MSK, bench stock listings, and LSARs to support mission requirements.

(5) Reviewing and assessing the repair level analysis (RLA) and the resulting SMR codes. Make recommendations based on test experience.

(6) Conducting a random statistical sample of provisioned items to draw conclusions about overall provisioning adequacy.

(7) Supplying the required test data to the provisioners.

g. Evaluation Criteria:

(1) As a rule, quantitative evaluation criteria are appropriate for supply only during follow-on OT&E (FOT&E). Until then, the supply support system is either the responsibility of the contractor or is in the initial buildup stage for organic Air Force support.

(2) The planner can apply primary evaluation criteria such as PMCB and NMCS.

(a) Key measurements of reliability (mean time between maintenance (MTBM), mean time between demand (MTBD), etc.) and base-level repair capability (NRTS rates, etc.) at the component level can be compared to those used in the provisioning process.

(b) However, missing the mark on these comparisons will not in itself mean an item has been underprovisioned or overprovisioned. It will simply identify a candidate for further evaluation. Such factors as anticipated reliability improvements, improved technical data, and increased base-level repair capability must then be considered before determining that a component is underprovisioned or overprovisioned.

(3) Another useful criterion for identifying potential supply problems is to identify the top PMCS/NMCS contributors and the top cannibalization items.

3-6. Technical Data. Technical data are the link between personnel and equipment. Traditionally, they have been paper products, but the current USAF trend is toward automation, i.e., digital technical data. Adequacy, usability, completeness, correctness, and understandability of technical data should be assessed. The assessment of technical data is a subjective process.

a. General Considerations. The following factors should be considered in developing objectives and MOEs:

(1) Adequacy of the contractor's plan to

provide validated manuals in time to meet the Air Force verification schedule.

(2) Adequacy of the Air Force verification plan to provide formal publications in the most efficient and cost-efficient and cost-effective manner.

(3) Provisions for checklist format where sequential steps and tasks to be accomplished make them appropriate.

(4) Adequate notes, cautions, and warnings for personnel safety and protection of equipment.

(5) Identification of hardness critical processes and hardness critical items.

(6) Usefulness of the form of technical data (automated, checklists, pocket size, etc.).

(7) Adequacy of illustrations.

(8) References to special tools and test equipment.

(9) Utility of table of contents and index.

(10) Need to refer to other TOs and manuals to complete tasks.

(11) Consistency in installation, hardware, and safety provisions between related manuals.

(12) Adequacy of troubleshooting procedures.

(13) Adequacy of illustrated parts breakdown.

(14) Readability of the TO.

b. Test Methodology. The test team should participate and provide inputs through the program office into the review of the technical data specifications, table-top reviews of technical data, and the contractor's validation effort. The team should evaluate the technical data during its day-to-day use and participate and provide inputs to the program office during in-process reviews to ensure all previously found discrepancies are corrected.

c. Data Requirements:

(1) Data requirements usually include AFTO Form 158 for preliminary technical orders (TO), AFTO Forms 22 (Technical Order System Publication Improvement Report and Reply), formal publications, or AFTO Forms 27 (Technical Order System Publication Change Request (PCR)) (submitted IAW TO 00-5-1, Air Force Technical Order System) for preliminary publications. These are the deficiency reports for technical data. Also needed will be the proposed and actual delivery schedules of the publications and the validation and verification plans and schedules. Properly designed questionnaires may also prove helpful. The planner will require the minutes and worksheets from any specification reviews, prepublication reviews, prepublication reviews, or other such meetings.

(2) References:

(a) AFR 8-2, Air Force Technical Order System.

(b) AFR 310-1, Management of Contractor Data.

(c) AFSCM 310-2, Technical Publications Acquisition Management.

(d) TO 00-5-1, Air Force Technical Order System.

(e) TO 00-5-2, Air Force Technical Order Distribution System.

(f) TO 00-5-15, Air Force Time Compliance Technical Order System.

(g) MIL-L 8031, List of Applicable Publications (LOAP).

d. Assessment. The assessment of technical data should determine the adequacy of the technical data to support mission requirements, assess the timeliness of the delivery of the to support operational requirements, and identify technical data deficiencies with recommendations, when appropriate.

e. Assessment Criteria. Technical data can be assessed in terms of the adequacy, usability, completeness, correctness, and understandability of the data for their intended use. This is a qualitative assessment requiring judgmental criteria. Technical data can also be assessed in terms of the delivery of technical data versus the required schedule.

3-7. Packaging, Handling, and Transportation (PHT). PHT assessment involves an effort to ensure the capability to transport, preserve, package, and handle all system, equipment, and support items. Mission, design specifications, item configuration, safety, geographic and environmental considerations, or packaging and preservation concepts may dictate requirements. OT&E interests range from the adequacy of packing materials and techniques and preservation procedures for shipping spare parts (particularly cure-dated and fragile items) to the transportability of an entire system, including its teardown and reassembly. Such items as protection from weather and from rough handling are prime considerations. The assessment of handling and transportation equipment is normally a qualitative process.

a. General Considerations. These factors should be considered in developing specific objectives and MOEs:

(1) Outsized components and peculiar requirements for packaging, crating, handling, or special precautions.

(2) Adequacy of provisions for timely deployment and redeployment.

(3) Provisions for handling and transportation within the organization.

(4) Adequacy of shipping containers.

(5) Suitability of handling, carrying devices, and protective devices (dust, shock, impact, moisture).

b. Test Methodology. Packaging specialists should assist in the evaluation of handling and transportation. They can be assigned to the test team on a TDY basis from the ALC which has the prime responsibility for the weapon system. The following methods of assessment should normally be used:

(1) Review the contractor's and ALC's packaging and transportation plans for adequacy and compliance with the governing directives and specification; evaluate the equipment, when the test team receives it, using a test team-developed evaluation form and checklist; and identify deficiencies as the equipment is used on a day-to-day basis. (When suspected deficiencies are identified, the test team should examine and compare the equipment to applicable directives to determine compliance with, or adequacy of, those directives or specifications listed below.)

(2) When using either the MDCS or SEDS, the test team should review maintenance data for incidents of when-discovered code Y, "upon receipt or withdrawal for supply stocks," and how-malfunction code 086, "improper handling." The team should investigate these incidents for shortcomings with handling and transportation equipment.

c. Data Requirements. Data requirements generally include contractor and depot packaging and transportation plans, test team assessment form or checklist, MDCS and SEDS data products, and applicable directives and specifications. These usually include at least the following:

(1) AFR 71-1, Packaging Management.

(2) AFR 71-4, Preparing Hazardous Materials for Military Air Shipment.

(3) AFR 71-9, Air Force Packaging.

(4) AFR 80-18, Department of Defense Engineering for Transportability.

(5) AFLCM 71-1, AFLC Packaging and Materials Handling Policies and Procedures.

(6) MIL-STD 1367, Packaging, Handling, Storage, and Transportability Program Requirements (For Systems and Equipments).

(7) MIL-P 9024, Packaging, Handling, and Transportability in System/Equipment Acquisition.

d. Assessment. The assessment of transportation and handling equipment should normally include the factors discussed herein.

e. Assessment Criteria. Subjective judgments of test team personnel, identification of damaged components or equipment attributable to handling and transportation equipment, and comparison of the equipment to applicable directives and specifications are

some criteria that may be used in assessing PHT.

3-8. Maintenance Facilities. Maintenance facilities planning is based on engineering, operational, and maintenance requirements. The test team should monitor all maintenance activities to identify any requirements that have not been satisfied. The test team should use AFM 86-2, Standard Facility Requirements, as a guide. Close coordination with the prime ALC and using command is important in this assessment, and the test team should review all applicable facilities plans against test experience to make sure the proper factors have been used in determining facilities requirements. The LSA-012 report may be a useful tool in determining the various operations and maintenance (O&M) functions to be performed in planned facilities. Such items as heavy maintenance docks, work areas, storage requirements, wash rack, test cell requirements, etc., are of interest.

a. General Consideration. These factors should be considered in developing objectives and MOEs:

- (1) Programmed and forecast utilization rates.
- (2) Number of systems and units per squadron or wing.
- (3) TMDE authorizations per squadron or wing.
- (4) SE authorizations per squadron or wing.
- (5) Clean-room requirements.
- (6) Wash rack, phase inspection dock, fuel cell, and similar requirements.
- (7) Munitions storage requirements.
- (8) Utilities requirements.
- (9) Security requirements.
- (10) Environmental control requirements.
- (11) War readiness material (WRM) storage requirements.
- (12) Manpower authorizations.
- (13) Forward operating location and deployment requirements.
- (14) Hazardous materials handling and disposal requirements.

b. Test Methodology:

(1) The evaluation of facilities may cover site activation activities by working with the site activation task force (SATAF). On programs not employing a SATAF, the evaluators may work with the prime civil engineering activity responsible for the survey and planning of the facilities.

(2) The contractor's facilities program plan and the base and MAJCOM facilities program plans should be reviewed and compared with test experience. AFM 86-2 com-

putations may be used when applicable. Quantitative inputs for these computations should come from the results of the reliability, maintainability, and manpower evaluation objectives.

(3) Maintenance activities should be monitored and reviewed periodically in light of facilities requirements to identify and report any unique requirements, new facilities, additions, or modifications needed to support the system.

(4) A questionnaire may be used to summarize opinions in the area.

c. Data Requirements. Data requirements will typically include the following:

- (1) Contractor's facilities program plan.
- (2) Base and MAJCOM facilities program plan.
- (3) Data elements required to accomplish AFM 86-2 computations. (Obtained from reliability, maintainability, and manpower objectives and SE tables of allowances.)
- (4) Minutes of site activation conference, meetings, and working groups.
- (5) Results of facility evaluation questionnaire.

d. Assessment. The assessment may include review of programmed facilities requirements in light of test experience and review of activities to identify any unique, new, or altered facilities requirements which have not been previously identified or programmed.

e. Assessment Criteria. Compare programmed facilities versus computed requirements, with an assessment as to whether adequate facilities are available or being programmed.

3-9. Maintenance Training. The assessment effort will be to assess whether Air Force maintenance personnel with system training can maintain and support the system in its intended environment. This includes an assessment of specialties and skill levels required to perform base-level tasks, as well as the need for new specialties or unique training requirements for existing specialties to support system-unique requirements. It also includes assessing the maintenance training conducted prior to and in support of OT&E and providing information to assist in refining training requirements, technical training materials, and facilities required to support systems during operational use. Air Training Command (ATC) provides the training evaluations.

a. General Considerations. Training assessments include the following:

- (1) Assess whether any aspects to the system will impose adverse or unreasonable

training support requirements beyond those generally acceptable to, and standard within, the technical training community.

(a) System aspects include design or construction of subsystems, operational support equipment, software, and technical data; maintenance or logistics concepts; and quantitative and qualitative personnel requirements.

(b) Training support requirements include training development lead times or procedures, course lengths, technical training material suitability, quantities and costs, facilities, instructors, and logistics support.

(2) Assess the ability of the training program being developed (including instruction and course preparation/contents, technical training material identification and procurement actions, support requirements for technical data, facilities and logistics support, and associated scheduling actions) to match the using and supporting commands' requirements for training maintenance personnel.

b. Test Methodology. The methodology for the assessment should include the following activities by the evaluators:

(1) Review training plans, course documents, technical data, and system test results for impact on training support.

(2) Conduct interviews, as required, in support of test objectives.

(3) Conduct over-the-shoulder observations of tasks being accomplished during test activities.

(4) Participate in the service reporting system.

(5) Conduct interviews with supervisory and maintenance personnel to determine if training provided in support of OT&E adequately prepared the graduates to accomplish the T&E objectives.

c. Data Requirements:

(1) Data requirements for the evaluation may include the following:

(a) Contractor maintenance instructions/preliminary technical data.

(b) Logistics support analysis reports (LSA-002, -011, and -014).

(c) Maintenance concepts.

(d) Instructional systems development (ISD) data base and documents.

(e) Training documents (plans, training standards, plans of instructions, course charts, etc.).

(f) Air Force training regulations and manuals.

(g) Target population, training program requirements, and other training manning documents.

(2) References:

(a) AFR 50-9, Special Training.

(b) AFR 50-18, Interservice Training.

(c) AFR 55-43, Management of Operational Test and Evaluation.

(d) ATCR 800-1, Program Management, and volumes I and II, ATC Participation in Systems Acquisition.

(e) AFLCP/AFSCP 800-34, Acquisition Logistics Management.

d. Assessment and Assessment Criteria. Quantitative criteria are not normally available to address this area. The assessment will be based on the subjective opinions of test team maintenance and training personnel as to the ability of the training program to support the system.

3-10. Maintenance Planning. Maintenance planning assesses the adequacy of all actions defined for each significant maintenance task required to support the weapon system. Specifically, it is the assessment of the planning for all the activity required to achieve, restore, or maintain the operational capability of the system or equipment. MOEs for this objective will be the subjective assessments (backed up by qualitative and quantitative data from the other objectives) of the adequacy of maintenance and logistics planning to provide the required support.

a. General Considerations. The following factors should be considered in developing objectives and MOEs:

(1) The ability to effectively and efficiently support the weapon system.

(2) The suitability of repair-level decisions.

(3) The use of organic, interim contractor support (ICS) or contractor logistics support (CLS) resources for organizational-, intermediate-, and depot-level hardware and/or software support.

(4) The ability to adequately support deployment requirements.

(5) The adequacy of integrated diagnostics concepts.

(6) The validity of the assumptions the maintenance concept/plan was based on.

b. Test Methodology. The methodology for this objective may include the following:

(1) A comparison of the logistics factors used to compute the RLA and SMR codes with conditions actually being experienced or projected for the mature environment.

(2) A comparison of the key programmed suitability performance parameters with those actually experienced or projected and the planning actions being taken to adjust or accommodate differences. Consider such factors as the following:

(a) R&M performance.

(b) Integrated diagnostics capability.

- (c) Supply provisioning.
- (d) Technical data adequacy.
- (e) Support equipment suitability.

(3) Changes in the maintenance concepts and appropriate adjustments or changes in maintenance planning.

(4) Review of all the suitability objectives for problems and the adequacy of maintenance planning to overcome or compensate for those problems, when applicable.

c. Data Requirements. Data for this evaluation will typically come from the other suitability objectives. If ICS is planned until the system reaches initial operational capability (IOC), the transition plan to organic maintenance must be obtained and reviewed.

d. Assessment. The assessment should be designed to identify areas where maintenance planning is not adequate to support the required level of mission performance and to make appropriate recommendations. As a minimum, these areas should be assessed:

(1) The ability of the maintenance planning to result in the necessary actions and support to ensure the system or equipment attains required operational capability.

(2) The specification and realism of criteria for repair times, maintainability and reliability characteristics, SE requirements, maintenance skills, and facilities requirements.

(3) The adequacy of the RLA and whether the most efficient and economical repair levels have been established. (This evaluation can also be supported by quantitative data from other appropriate objectives.)

(4) The scope and completeness of transition plans designed to facilitate transfer of logistics support from contract to organic capabilities.

(5) For CLS, provisions for adequate documentation, source code, and skills/experience levels may be assessed to identify potential hardware or software problem areas that could affect system support, configuration management, or mission performance.

e. Assessment Criteria. The assessment criteria may be linked to the criteria from the availability objective. Whenever possible, however, the test team member should use quantitative data to support findings.

3-11. Other Considerations. Although the following factors are not normally categorized as operational suitability objectives, they may play a significant role in estimating a system's wartime capability. Many of them apply to more than one of the preceding elements (supply, support equipment, etc.).

a. Interoperability is the ability of systems, units, or forces to provide services to, and accept services from, other systems, units, or forces and to use the services so exchanged to enable them to operate effectively together (AFR 80-14). In a logistics perspective, interoperability may be viewed from a system or subsystem viewpoint.

b. Compatibility is the capability of two or more operational items/systems to exist or function as elements of a larger operational system or operational environment without mutual interference (AFR 80-14). Compatibility may also be viewed from a system or subsystem perspective.

c. Wartime usage rates are the rates at which system and their supporting subsystem, SE, and spares are consumed/used under war conditions. Operational suitability evaluations should be done in context of the planned wartime usage rates.

d. The use of chemical, biological, radiological (CBR) warfare protective clothing and equipment must be considered when estimating the utility of system operated under CBR threat conditions.

e. Human factors is a body of scientific facts about human characteristics. The term covers all biomedical and psychosocial considerations. It includes, but is not limited to, principles and applications in the areas of human engineering, personnel selection, training, life support, job performance aids, and human performance evaluation (MIL-STD 721). Maintainability evaluations should take into account the impact of human factors on ease of maintenance, accessibility, and similar considerations.

f. Depot support of emerging systems is often immature during OT&E. As a result, assessments/evaluations of this area are not performed, except for a review of planning documents. Depot activities may be modeled to determine impact on field operations and maintenance. Such modeling should be planned for, coordinated, and verified (if not validated) prior to the start of test. Test planners and test teams should be alert to the need for adequate depot planning and should review available data.

g. Safety is freedom from conditions which can cause death, injury, occupational illness, or damage to or loss of equipments or property. Formal safety assessments are normally conducted by HQ AFOTTEC/SE, but safety considerations should be included in maintainability or logistics supportability assessments.

Part II

KEY OPERATIONAL SUITABILITY ACTIVITIES

Chapter 4

PREPARING FOR TEST PLANNING REVIEWS (TPR)

4-1. General:

a. Test planning reviews are major parts of a dynamic and evolving AFOTTEC process of developing a test plan. The process begins with developing a test concept and a description, including rationale and assumptions, of the test structure, evaluation methodology, and management approach that will be used to evaluate the operational effectiveness and suitability of a weapon system. It should be understood the test concept will mature with changes in the program and will eventually transition into the OT&E test plan.

b. TPRs provide a structure and methodology for planning an executable OT&E. They ensure continuing, consistent, and compressive staff review of the test concept and adequacy of test planning. In addition, they provide feedback, direction, and assistance to the test support groups (TSG).

c. There are currently three TPRs (each may be preceded by an internal LG review with material presented limited to suitability test and evaluation). The AFOTTEC Commander is the approval authority for all test planning conducted during the TPR process.

- (1) TPR #1: Test Concept Approval.
- (2) TPR #2: Test Concept Update.
- (3) TPR #3: Draft Test Plan.

d. Figure 4-1 depicts the role of TPRs in the OT&E planning process.

4-2. Test Concept Approval:

a. From the time a work directive is issued and the test manager convenes a TSG, the suitability test planner will become deeply involved in thinking, reading, discussing, and learning about the system needed, the system expected for OT&E, and organizational and procedural details of OT&E itself. The efforts/tasks before the planner may seem monumental, especially if the planner is new to the OT&E community. Although training in OT&E is available, the suitability test planner may find it too general to assist in tackling each specific task. Therefore, interface with one's peers, supervisors, and the TPR committee members is a must for successful development of a test concept.

b. In preparing for TPR #1, the TSG must develop a feasible test concept that includes

user requirements, operational environment, focus of test, test scenarios, and test resources. These five areas may be reviewed independently or concurrently by involved AFOTTEC division chiefs, AFOTTEC/XP, and AFOTTEC/CN in turn.

(1) Requirements Review. Operational requirements, derived from key program documents (e.g., MNS, ORD, and COEA), are evaluated on three aspects: completeness, relevance, and operational testability. Assumptions necessary to bridge voids resulting from insufficient information and program immaturity must be made and tracked until resolved. General considerations for this review include the following:

(a) Are requirements expressed in operationally relevant terms (reference AFP 52-9)?

(b) Are requirements clearly defined, either qualitatively or quantitatively, to enable development of comprehensive operational test criteria?

(c) Are requirements complete enough to accomplish the stated operational missions? Is each ILS element addressed?

(d) Do the requirements account for the operational environment in which the system will be deployed?

(e) Are the key (quantitative) requirements reflected in the requirements correlation matrix (RCM)?

(f) Are there unique requirements (software, diagnostics, etc.), and if so, are they clearly defined?

(g) Is each requirement testable during OT&E, and if not, is there a workaround?

(2) Operational Environment Review. The operational environment review should ensure the TSG understands the operational missions and the entire range of operating conditions when focusing the test effort. The review is a survey of the concept of operations, maintenance concept (or logistics concept), and threat environment. General considerations for this review include:

(a) Do the operational mission scenarios pose unique challenges for logistics support during OT&E or during deployment?

(b) Does the maintenance concept reflect current Air Force policy, and can it be represented during OT&E? If not, is contrac-

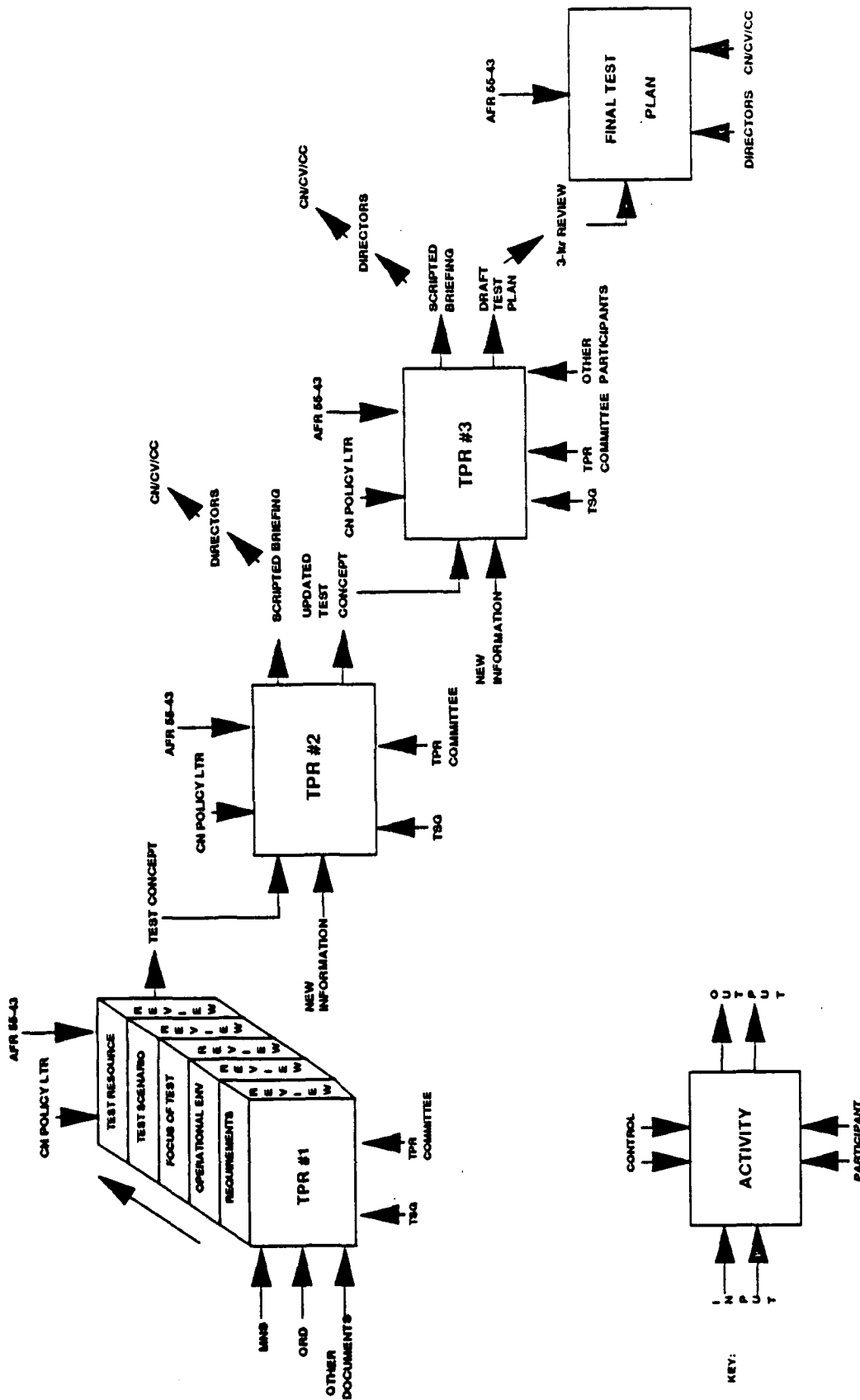

Figure 4-1. OT&E Planning Process

tor logistics support (CLS) the only alternative or are there workarounds to minimize/avoid CLS? What is the impact of not using CLS?

Note: Title 10, US code, Section 2399 restricts system contractor involvement in OT&E. In order to comply with the intent if not the letter of the law, suitability test planners should avoid CLS during active field testing, unless such support is identified for the deployed system, or it is not feasible to use government (organic) support resources.

(c) Are the skill levels and number of maintenance personnel required for the system's life specified? What minimum skills and maintenance manpower are required for test?

(d) What are the deployed maintenance conditions? Which conditions are planned for the test?

(e) Are maintainability demonstrations required? Can start and stop times for maintenance be defined?

(f) What role does integrated diagnostics have within the system's maintenance concept and concept of operations?

(g) What type of technical data is specified: paper, digital, or both? Which will be available for OT&E?

(h) What are the main suitability drivers for the system?

(3) Focus of Test Review. It is recognized that OT&E may not be able to test all aspects of the system; however, the suitability test planner should extract those elements critical to decision makers and evaluate the system based on its capability to accomplish those critical elements under operational conditions. This review consists of identifying the mission critical elements (MCE) related to mission conditions, the critical operational issues (COI) derived from the MCEs and measures that will provide the data to support an evaluation of the critical operational issues (reference figure 4-2). COIs are developed from user-identified critical system effectiveness and suitability requirements and are focused or established at the mission level. If, for example, reliability is an MCE for Mission X, there should not be a COI for "the reliability of the system during Mission X" (this should be an objective). Rather, the COI would be worded to ask how well the system performs (or how capable the system is) during Mission X with consideration given to reliability and any other element of suitability or effectiveness. Hence, suitability-related test objectives may apply to all COIs, instead of specific ones. Activities for this review should include:

(a) Contact the system's user to discuss

MCEs and identify COIs.

(b) Work with the TSG to limit the COIs to those clearly relevant to the system's intended missions.

(c) Begin thinking about how the COIs will be answered, what objectives are necessary, what measures will provide data to support an evaluation of the COIs, what long-lead resources may be needed, etc.

(d) Begin programming test resources with the Resource Development Division (RMX).

(4) Test Scenario Review. Test scenarios should replicate MCEs and conditions of the operational environment (mission scenario) to the maximum extent feasible. This review includes all planned OT&E test activities and must provide traceability from the focus of test to the proposed test scenarios. The review must also provide the TSG's evaluation methodology approach, including the planned confidence level and resulting scope of test. Considerations for this review include:

(a) How well will the planned test environment replicate the intended operational environment?

(b) Are there limitations caused by lack of resources, schedule constraints, test article availability, configuration, etc.? If so, what are the impacts? Are there workarounds to reduce the impact?

(c) If an area cannot be field tested, are there alternate methods for evaluation (e.g., simulators, models, studies, etc.)?

(5) Test Resource Review. Test resources are the assets AFOTTEC needs available to complete OT&E. These assets include test articles, ranges, threat simulators, test team makeup, and anything else required to carry out a thorough OT&E. During this review, the TSG must identify test capability shortfalls and changes to test scenarios because of lack of existing/programmed test resources. Considerations for this review include:

(a) Is there a test program outline (TPO)?

(b) Can assets be shared among other tests at the test site or with other agencies?

(c) Is the data collection system for suitability OT&E defined and will it be available at the test site before the start of test?

(d) Are the quantities of test articles, people, supplies, etc., reasonable? Can you, the suitability test planner, justify these quantities?

(e) Are the appropriate data item descriptions, statement of work tasks, and system specifications included in the system contract to allow delivery of software data

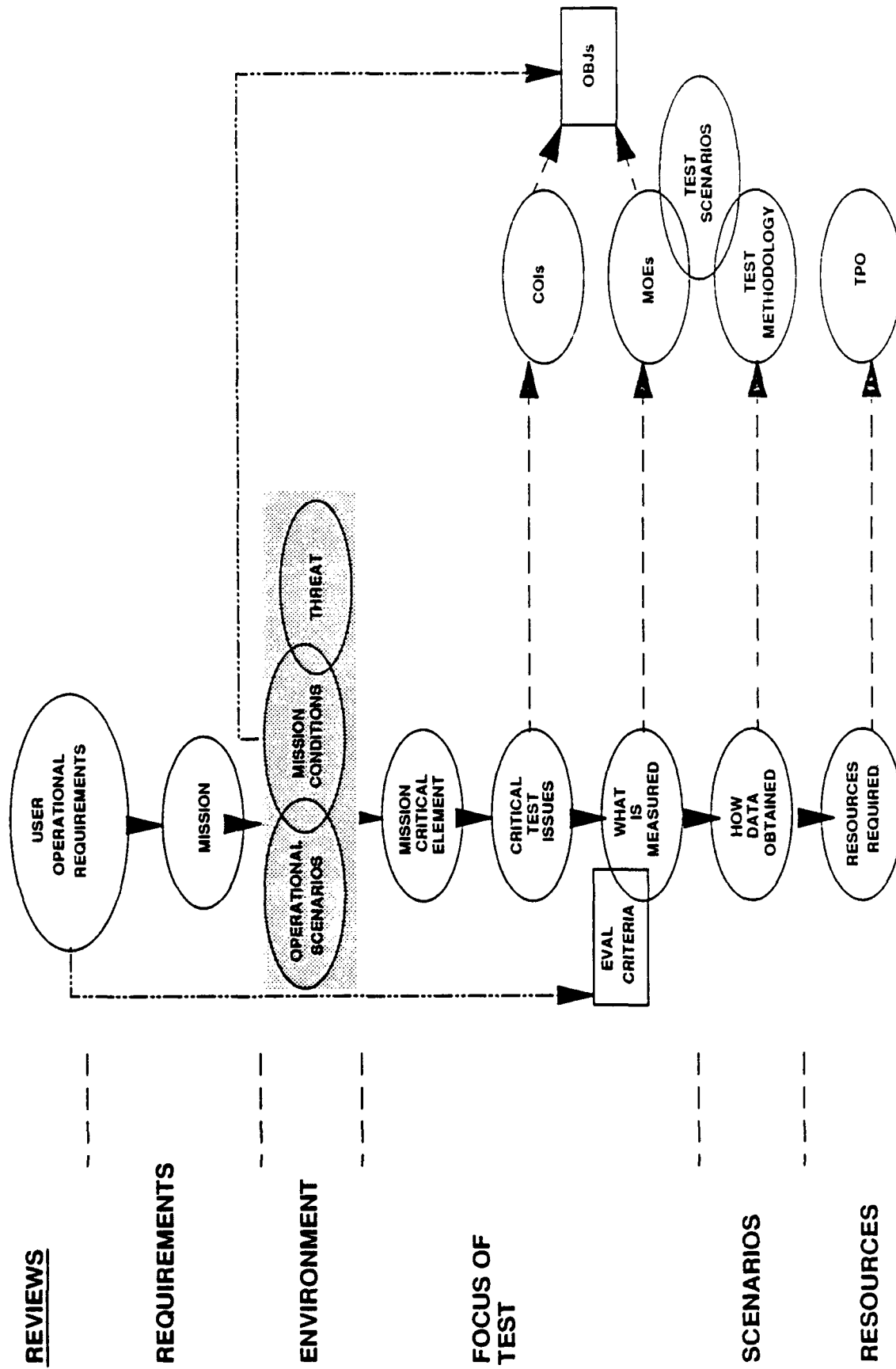

Figure 4-2. Hierarchy of Test Concept Elements

(documentation, source code, software deficiency reports) for AFOTTECP 800-2 series evaluations?

c. Assumptions made during test concept development to bridge voids resulting from insufficient information and program immaturity must be highlighted at TPR #1. As the test planning process progresses, the test planner will refine the test concepts to reflect a maturing program. Also included are proposed dates for completing significant planning activities (e.g., operational assessments).

d. The focus at TPR #1 (as well as TPR #2 and TPR #3) will be on content, not on the format of the presentation.

4-3. Updating the Test Concept:

a. The primary purpose of TPR #2 is to finalize the test concept. Programs will normally transition from XP to TE at completion of TPR #2. The TSG will, after TPR #1, continue to define, refine, and validate the test concept, resolving the issues and assumptions previously identified.

b. In preparing for TPR #2, the TSG should review all limitations, constraints, issues or concerns, and action items being taken to resolve them. The TSG should be able to:

(1) Discuss how and when the staff may become involved in the resolution process.

(2) Identify key activities/information which have become available since the previous TPR.

(3) Discuss the status of assumptions.

(4) Present a risk assessment of getting "undetermined" test results for user suitability requirements.

(5) Identify missing contractual requirements that will prevent the conduct of AFOTTECP 800-2 series evaluations. Describe what approach will be taken to resolve the software evaluation issue.

c. After TPR #2, the TSG will prepare a scripted executive-level test concept briefing and formally present it to the directors. After presentation to the directors, the briefing is presented to CN and CV/CC, in turn.

4-4. Draft Test Plan (with DMAP):

a. The primary purpose of TPR #3 is to allow the TPR committee to review and advise the TSG in development of the draft OT&E plan.

b. Before TPR #3 the draft test plan, DMAP, ORD, TEMP, etc., are made available to the logistics TPR committee member.

c. In preparing for TPR #3, the TSG should follow the guidance necessary to develop a draft OT&E plan and appropriate

supplements found in AFR 55-43. The DMAP, a separate document from the test plan, should be developed to the point of supporting the draft test plan (see chapter 7). The TSG should be able to:

(1) Explain the status of OT&E planning and provide rationale for the detail which has been added since the last TPR.

(2) Explain any departures between the proposed draft test plan and the approved test concept.

d. After TPR #3, the TSG will again brief the directors, CN, and CV/CC in turn.

4-5. TPR Example:

a. An example of a test concept is being developed in the AFOTTEC Test Concept Development Handbook. In the interim, the best source for information concerning content of a test concept is from recently completed TPRs. In addition, LG reference library contains extracts from past TPRs; however, because the OT&E planning process is dynamic, the suitability test planner should be thoroughly familiar with the latest policy and procedures/guidance on TPRs and any specific direction from the test manager.

b. An example of a draft test plan is contained in AFR 55-43. Examples of test plan supplements including data management and analysis plans are available in the AFOTTEC archives.

4-6. Lessons Learned:

a. Test Concept Development:

(1) Know the program thoroughly (key decision milestones, technical features, acquisition strategy, etc.). Plan test events to provide reports for key decision milestones.

(2) A good suitability approach is a cooperative effort. Get everybody involved. Pass early drafts around your branch for comment. Check with personnel who have recently formulated briefings for the most recent guidance and suggestions. The earlier you get feedback, the better.

(3) Have the test manager involved, even in internal LG suitability reviews. He/she can also answer overall program and operational effectiveness questions (highly desirable for division-level briefings; essential for directorate level).

(4) For the reliability and availability objectives, differentiate between the statement of the objective and the MOE. For example, weapon system reliability (WSR) should be an MOE, not an objective. The term WSR should not be used as an objective (as in "Evaluate High Speed Antiradiation Missile (HARM) WSR"). When used as an MOE, WSR should be explicitly defined (i.e.,

at what point in a mission does the measure start and when does it stop). Likewise, for the availability objective, "availability" is not an MOE.

(5) Examine carefully the issue of dormancy and its impact on reliability. Use a separate objective for "dormant reliability" only when dormant storage is a significant factor in the operational use of the item (i.e., a "wooden-round" munition). Some items (such as the HARM) have long periods of storage between operational uses but receive a checkout before being used. If you believe it worthwhile to examine the impact of these storage periods on reliability, include this examination in the methodology of the reliability objective. See attachment 2 for discussion on dormant reliability.

(6) Look carefully at objectives for which you have selected numerous MOEs. In some cases the MOEs can be generalized to a single MOE and the various aspects of the MOE incorporated in the evaluation method. For example, the two MOEs "mean loading and checkout time for a HARM" and "mean loading and checkout time for gravity weapons" can be combined into a single MOE "mean loading and checkout time" with the variables included in the method.

(7) Get your requirements for OT&E (e.g., Air Force hands-on maintenance, contractor support) into the request for proposal (RFP). Talk with SPO personnel so they understand and support the OT&E requirements. Follow through to make sure your requirements are included in the contract. Provide whatever support you can to make sure the requirements do not get negotiated out before the final contract is signed. This is critical for requiring the contractor to use data forms/equipment peculiar to government data collection systems and requiring the contractor to use the Service Reporting System (TO 00-35D-54). See LGOI 400-6, Request for Proposal (RFP) Checklist, for further ideas.

(8) Be thorough in responding to SPO data calls to ensure you request the right data from the contractor. Be concerned with only the data you need. Review logistics support analysis deliverables and select reports that will be needed to support your test objectives.

(9) Ensure enough assets are procured for test and the delivery schedules for support equipment, training, technical data, etc., will support a thorough suitability evaluation. Do not automatically accept the number of items the SPO says will be available for test. Determine what you need and work to get that number of items. If you have to accept fewer items, provide as part of the approach

(under limiting factors) how this compromise will impact the validity of the test results.

(10) Study and influence the test conditions under which contractual R&M demonstrations are conducted so that they produce operationally relevant data.

(11) Agreement on system design, configuration, and testing concept is difficult to achieve among the R&D organization, test agency, using command, and supporting command during the concept exploration phase. The logistics evaluation manager must plan for this condition.

(12) Data availability for evaluation is limited. Agreement as to what data will be available and from whom is difficult to achieve. Because of this, evaluations will initially be limited to best judgment or expert opinions.

b. Measures of Effectiveness to Satisfy Test Objectives:

(1) Test planning depends on developing MOEs that are directly applicable to the test objectives. The test planner must select MOEs which directly relate to the system's ability to accomplish its mission. Selected MOEs should also be sensitive to mission impacts caused by particular subsystems or procedures.

(2) When establishing MOEs, recognize which events occur during peacetime, wartime, and the transition from peacetime to wartime. For many systems, the employment, deployment, and logistics support concepts are implemented in a fully pre-planned and controlled sequence of events. This sequence starts at a random time during normal peacetime operations, passes through an increased readiness stage, and terminates with either an execution order or an order to cancel the increased preparedness conditions. While it may be appropriate to use average times for MOEs (e.g., MTBM) to describe a system's capability during peacetime operations, it may or may not be appropriate to use averages to describe the system's capability in wartime or surge situations. In this case, it may be necessary to define two levels of MOEs.

(3) The test planner must always keep in mind the feasibility of potential MOEs. Data management and analysis requirements are driven by MOE selections. The data management and analysis plan (DMAP) (discussed in chapter 7) describes the test data to be collected, how they will be collected, and how they will be processed to support each MOE. MOEs must be calculated on the basis of obtainable test data. This means the test planner should keep in mind whether the necessary data and calcu-

lation and analysis techniques will be available at the proper time during test.

(4) Operational suitability evaluations encompass a hierarchy of critical OT&E issues, objectives, and MOEs which are interrelated vertically and horizontally. The planner should establish evaluation criteria at the system level for the fewest number of MOEs that can satisfy the decision maker's concerns. Circumstances may arise, however, when it is desirable to establish MOEs and evaluation criteria which focus management's attention on a particular area of concern.

c. Logistics Evaluation Management:

(1) Logistics evaluation managers for some programs have had significant difficulty in obtaining user requirements that would facilitate timely identification of COIs and development of test objectives and measures of effectiveness.

(2) External influences and decisions can have major impacts on test planning. These can range from program starts and stops, major policy shifts, or SPO-generated contract changes. Each can radically change the COIs and, therefore, test planning. To cope with these pitfalls, the logistics evaluation manager must stay abreast of programmatic developments and keep the information flowing.

(3) The logistics evaluation manager must also cross-check the information acquired for test planning to ensure it is up to date and consistent. Incomplete operational requirements data may lead to inconsistent contract specifications. Incompatibilities between contract requirements and user requirements are not unusual. In such cases, LG product division action is required to elevate and resolve disconnects, and logistics evaluation managers should expect to see the contract or the user requirements changed. Unfortunately, it is usually the user who changes, since cost and schedule considerations usually keep the SPO from changing the contract unless the mission requirement in question is a paramount concern to the user. Therefore, the test planning in this area should be particularly thorough to ensure it will withstand the possible subsequent challenge.

(4) AFOTTEC/LG action officers must accurately forecast test requirements (i.e., munitions, aircraft spare parts, manpower, test equipment, tooling, facilities, vehicles, etc.) as soon as possible in the IOT&E test planning process via the TPO. Munitions requirements should be forecast at least 2 years in advance so AFOTTEC requirements can get into the USAF Tactical Air Munitions Plans and Allocation cycles. All other logistics test resources must be followed up

by the action officer via message, letter, etc., between TPO cycles to ensure these OT&E critical test assets are there when you need them.

(5) Some SPOs have not required contractors to use SEDS for R&M data collection and processing on the basis that it costs too much. Attempt to convince the SPO early enough that SEDS should be used so it is not an add-on cost. Use AFR 80-14 and AFSC supplement 1 to AFR 80-14 as references. If unsuccessful, plan for the time and personnel required to translate the data into an Air Force (or government) data base. This will serve to limit reliance upon contractor data bases.

(6) SPO acquisition strategy can have adverse impacts on test planning. Some SPOs have been reluctant to conduct maintenance demonstrations, establish joint reliability and maintainability evaluation teams (JRMET), and conduct adequate integrated logistics support planning. The effect on test planning can be that logistics support information will be lacking and OT&E may be required to generate some information which would normally be available from DT&E. The logistics evaluation manager will need to expend extra effort to ensure the test plan adequately addresses these possible deficiencies.

(7) All available skills within HQ AFOTTEC/LG should be brought to bear on the test planning process. The logistics evaluation manager should contact all appropriate personnel within the LG staff to draw upon their experience in preparing the test plan. One way to do this is to use a team approach within HQ AFOTTEC/LG. The logistics evaluation manager, software evaluation manager, and logistics analyst should attend the AFOTTEC TSG to increase their knowledge of the program and reduce levels of coordination on test planning documentation.

(8) Programs for which test concepts (or approaches) were developed several years in the past must be carefully scrutinized. Many factors pertaining to the program may have changed, e.g., political interest, using command need, and technology available to system concept. These factors could result in changes to COIs. In turn, test objectives may need to be updated. Test objectives should be redeveloped if a sound evaluation is doubtful. Evaluation should be changed from quantitative to qualitative if available data are sketchy:

(9) The test planning during the concept exploration phase should be designed to capture the major system suitability drivers. For example, manpower limitations may

necessitate development of new technology to conduct repairs.

(10) Stability of personnel assigned to a test program is a significant aid to developing a sound test plan. Replacements, when necessary, should be well briefed before assuming test planning responsibilities. In addition, good records of all activities pertaining to the test program should be kept to assist in continuity of the program.

(11) Do not let pride of authorship interfere with development of ideas. However, be prepared to fully defend your ideas during development of the test concept. Questioners may not, and probably do not, understand

the program as thoroughly as you do.

(12) An AFOTEC assignment is, in some ways, equivalent to a "mini-Air Staff" assignment. Therefore, logistics evaluation managers must have a wide range of knowledge. They must understand the organization and functions of Office of the Secretary of Defense (OSD), HQ USAF, AFSC, AFLC, and the operating commands. They must become familiar with the planning, programming, and budgeting system to ensure their resource requirements are properly provided for. They must be constantly aware of the roles and impacts these agencies and systems can have on test planning.

Chapter 5

PREPARING FOR OPERATIONAL ASSESSMENTS (OA)

5-1. General:

a. Operational Assessments are independent appraisals of the operational effectiveness/suitability aspects of a system. Early operational assessments (EOA) are operational assessments which support major milestones and decision points before Milestone II. Normally, TSGs will conduct OAs (usually before Milestone IIIA) on major defense acquisition programs with DOT&E oversight. The central theme is to interact with the operating command and developer to ensure the establishment of clearly defined operational requirements and meaningful OT&E criteria.

b. AFR 55-43 outlines the planning and reporting policy for OAs. Normally a plan is not required; however, the TSG and especially the logistics staff should formulate an OA plan (even a strawman plan) to focus the TSG's efforts and meet schedule milestones for reporting purposes. OA reports (i.e., scripted briefings) must address six areas/objectives:

(1) Planning issues concerning readiness for OT&E, schedule adequacy, and resource availability.

(2) Status of documentation.

(3) System development and maturity aspects that may impact the ability to start/complete OT&E.

(4) Identification of programmatic voids.

(5) Conclusions from special field test activities.

(6) Identification of significant trends.

c. The following paragraphs outline general suitability-related consideration for OAs. These considerations are based on activities which should be addressed/complete before the system progresses in the defense acquisition process. The logistics staff should tailor the considerations for their specific program's milestone/decision point. Assistance/support from implementing, supporting, and using agencies is permitted by AFR 55-43; however, the rating should reflect an independent AFOTTEC assessment of the system/program. There are four rating categories as follows:

(1) Green: No issue or issue/area/objective being adequately addressed.

(2) Yellow: Issue requires additional attention.

(3) Red: Significant areas of concern or voids exist that will impact OT&E and/or may prevent the achievement of specified operational requirements.

(4) White: Issue/area/objective could not be assessed.

5-2. Milestone I OAs. Historically, OAs for Milestone I have not been required. It is not certain this trend will continue as new acquisition policy and documents are developed (e.g., cost and operational effectiveness analysis). Although suitability considerations are presented herein for possible Milestone I OAs, they apply equally well to OAs for Milestone II.

a. **Planning Issues.** There are no considerations for planning issues concerning readiness for OT&E, schedule adequacy, and resource availability. This area should be assessed "white."

b. **Status of Documentation.** Considerations for this area include:

(1) Has the ORD been validated? Are the R&M and operational requirements clearly stated and feasible?

(2) Has the baseline logistics support concept been validated, and have the major support items (hardware and software) been identified?

(3) Has the approved depot support concept (hardware and software), including maintenance and material support requirements, been provided as an annex to the ORD?

(4) Is the integrated logistics support plan in place with plans to conduct tradeoffs among design characteristics, manpower skill levels, and support concepts?

(5) Is the analysis of support cost drivers complete (with target improvements) and reflected in support resource requirements?

(6) Are the operational and support concepts complete with linkage to support resource requirements?

(7) Have R&M design parameters been developed and compared to current system? Has the need for R&M growth management plans been identified?

(8) Have plans been initiated to consider system test and evaluation, preplanned product improvements, program management, etc.?

(9) Have plans been initiated to ensure LCC disciplines are applied through the acquisition process?

(10) Have all software requirements for OT&E been incorporated in system contracts? Has the software maintenance concept been developed, and have the associated

contractual requirements been placed on contract?

c. System Development and Maturity. Considerations for this area include:

(1) Are alternate concept studies complete?
 (2) Has a baseline system been identified?

(3) Have technology or system concept demonstration been completed?

d. Programmatic Voids. Considerations for this area include:

(1) Has the DPML/ILSM, ALC/SPM been identified?

(2) Are there sufficient experienced logisticians in place with future needs identified and programmed?

(3) Has the logistics budget been established? Were standard factors used? Are the logistics cost drivers identified?

(4) Do the cost requirements reflect the overall baseline support concepts?

(5) Do the logistics business strategy options support the design and support options under review?

(6) Have ILS elements been given appropriate weight in source selection?

(7) Is LSA on contract including integrated provisioning requirements and explicit tailoring instructions to ensure LSA impacts the design decision process?

(8) Have product performance agreements or system warranties (see AFR 70-11) been considered?

(9) Have the software maintenance responsibilities been defined?

(10) Have the details of the software maintenance concept been translated into an acquisition contract line item to procure the software maintenance/support capability?

e. Special Field Test Activities. There are no considerations for this area. This area should be assessed "white."

f. Significant Trends. There are no considerations for this area. This area should be assessed "white."

5-3. Milestone II OAs. This milestone is usually the initial focus of the TSG's operational assessment effort. Depending on the program, the previous considerations may apply, and some considerations presented below may best be deferred to Milestone IIIA. Also, the considerations below may apply to more than one area.

a. Planning Issues. Considerations for this area include:

(1) Have facility requirements been identified and linked to the budget to ensure availability at need date?

(2) Is a provisioning strategy in place

and compatible with contractor support strategy? Are review schedules developed?

(3) Has the need for a postproduction support plan been identified?

(4) Do ILS elements continue to be given appropriate weight in source selection criteria? Have ILS data requirements been tailored?

(5) Do contracts clearly reflect baseline operational, maintenance, and support concept requirements?

(6) Is critical logistics support related hardware and software on contract or identified for future contracts?

(7) Is acquisition of engineering data on contract and scheduled for delivery as part of full-scale development and production contracts?

b. Status of Documentation. Considerations for this area include:

(1) Have training requirements been projected?

(2) Have software support requirements been identified?

(3) Have R&M performance criteria been established?

(4) Are R&M growth management plans complete? Have growth curves been developed with test schedule and reviews established to ensure compliance?

(5) Have the source and level of repair been documented?

(6) Has a cost/benefit analysis been completed?

(7) Are there plans to produce test-related documentation (e.g., TEMP, ORD, STAR, LISP, MESL, JRMET charter) in time to influence OT&E planning.

c. System Development and Maturity. Considerations for this area include:

(1) Have logistics supportability goals been established, and is there a strategy for achieving them?

(2) Have plans been made for mitigating the affect of logistics risks?

(3) Are major logistics support-related items (hardware and software) on track?

(4) Are there operational requirements which cannot be met by the "as-designed" system?

d. Programmatic Voids. Considerations for this area include:

(1) Are depot support requirements valid and keeping pace with program changes?

(2) Is the logistics manpower to support DPML, ILSM, ALC/SPM fully supported (current and projected)?

(3) Are the depot manpower support requirements supported in the budget?

(4) Has an LSAR review team been established?

(5) Is a logistics support review process in place?

(6) Have ICS and CLS projections been validated?

(7) Has a preliminary list of items for contractor support been developed?

(8) Have logistics risk drivers been re-examined?

(9) Is the logistics support concept keeping pace with program changes and reflected in the budget?

(10) Is the use of computer-aid acquisition and logistics support (CALS) determined and supported accordingly?

(11) Has the need for a Computer Resource Life Cycle Management Plan (CRLCMP) or software support plan been identified?

(12) Have depot support equipment and software been identified and programmed to support need date?

(13) Have tradeoffs been completed among design characteristics, manpower skill levels, and support concepts?

(14) Has a product performance strategy been developed, and is it linked to logistics support goals?

(15) Is depot activation on track with need or mitigation plan in place?

e. Special Field Test Activities. There are no considerations for this area. If such test activities are required, the TSG should report the test results.

f. Significant Trends. If any testing has been done, the TSG should review the test information and report any significant trends. No rating, prediction, or projection is required.

5-4. Milestone IIIA OAs. With early involvement in the system's acquisition program, and adequate OT&E planning, an OA for Milestone IIIA may be replaced by actual OT&E results, or even combined DT&E/OT&E results. If an OA remains a requirement for Milestone IIIA, the preceding considerations should be reevaluated to determine their applicability to this case. In addition, content/results from previous OAs and any lessons learned should be reviewed for possible application.

a. Planning Issues. Considerations for this area include:

(1) Are TOs, training devices, and other ILS elements needed for OT&E on contract?

(2) Are test team personnel, test articles, depot support, etc., fully programmed and documented in the TPO?

(3) Is training on schedule?

b. Status of Documentation. Considerations for this area include:

(1) Are manpower requirements documented and supported?

(2) Is postproduction support plan on contract and funded?

(3) Is the weapon system master plan in development?

(4) Has the engineering data management plan been updated? Are data on schedule for delivery?

(5) Has the postproduction support plan been developed, and is it on contract?

(6) Have software support plans or CRLCMPs been developed?

(7) Has the PMRT plan been developed?

(8) Has the Integrated Spares Acquisition and Support Plan been developed?

c. System Development and Maturity. Considerations for this area include:

(1) Are growth test results used to establish performance criteria in future production contracts?

(2) Are the logistics supportability goals still rationale?

(3) Have all major logistic risks been mitigated?

d. Programmatic Voids:

(1) Are ICS/CLS spares budgets supported?

(2) Do the development status and lead times of ILS deliverables match need dates?

(3) Is provisioning on contract with long lead items on or scheduled to be on contract to support operational need date?

(4) Is all equipment on contract or scheduled to be on contract to support operational need date?

(5) Is depot activation on track with the program?

(6) Is delivery of critical logistics support items (hardware and software) on track?

(7) Are facilities on track to support programmed need dates?

(8) Is training on schedule?

e. Special Field Test Activities. There are no considerations for this area. If any test activities have taken place, the TSG should report the results.

f. Significant Trends. Given any test results/information, the TSG should report significant trends such as continued performance discrepancies with respect to design acceptability (including R&M), maintenance concepts, and support resource requirements.

5-5. Sample Operational Assessments. As with TPRs, no single OA will apply to all programs generically. The LG reference library contains OAs completed on several programs. These should be reviewed and tailored as needed to satisfy test manager tasking for the specific program in question.

5-6. Lessons Learned. AFOTEC has been involved in OAs only since the 1988 time-frame. Experience with them is still evolving. However, some lessons learned are noted here (undoubtedly more will be added).

a. OAs are often required concurrently with TPR activities described in chapter 4. As such, the suitability test planner can experience cyclic intensity of work effort and work voids. These "peaks and valleys" can be minimized by using sound project management principles and tools. Also, designating a backup or alternate suitability test planner will contribute to balancing the work effort.

b. The suitability OA when first briefed to the logistics staff should be based on the judgment of the logistics action officers involved. As the TSG builds the official OA, the logistics evaluation manager should strive

to include those key areas of the suitability assessment.

c. Since OA uses a color-coded rating scheme, the logistics action officers should realize colors change for a variety of reasons. Insist on a fair rating which can be adequately substantiated.

d. Do not let pride of authorship interfere with the tasks at hand.

e. OAs/EOAs may or may not require an OA/EOA plan or report (a briefing may suffice for one or both). AFR 55-43 contains the key assessment areas for which the plan/briefing will be tailored. The test manager determines whether the plan or briefing approach will be used. The OA/EOA plan approach is more formal in both content and internal coordination requirements.

Chapter 6

PREPARING FOR TEST EXECUTION

6-1. General:

a. Preparing for test execution should begin before TPR #3 and requires frequent communication between AFOTTEC action officers and numerous participating organizations. Acquiring knowledge of these organizations, their role during test execution, and bringing together an actual test team are initial activities. Once the team is activated, training the team on both the OT&E and the system becomes a major focus for the test planner. The test team must understand what they are to do, how to do it, whom they contact for additional guidance, and when their jobs must be done. Ideally, the test team will visit HQ AFOTTEC before reporting to the test location to meet their TSG counterparts and discuss one-on-one all specifics of the OT&E.

b. Once prepared, the goal of the test team and TSG during test execution is to accomplish the objectives specified in the test plan. This chapter is not meant to be a detailed guide for each test team member for all types of systems that enter OT&E. Rather, this chapter and the next on data management provides general guidance on generic topics common to most OT&E programs.

6-2. Participating Organizations:

a. **Air Staff.** The logistics action officer may have contact with the Air Staff, the program element monitor (PEM), or the AFOTTEC liaison officer (OL-BA) located in the Directorate of Maintenance (AF/LGM), during test execution. HQ AFOTTEC/OL-BA is the primary suitability interface between HQ AFOTTEC and the Air Staff.

b. **Air Force Systems Command (AFSC).** When acting as the implementing command, AFSC establishes a system program office (SPO) which manages the acquisition of the system including development test and evaluation (DT&E). To conserve resources, AFOTTEC frequently participates in combined DT&E/OT&E. AFSC may provide the test sites, test assets, support equipment, and data reduction support required for combined testing.

c. **Air Force Logistics Command (AFLC).** As a supporting command, AFLC provides test team personnel, when specified in the test program outline (TPO), to aid in conducting suitability evaluations. Through the Air Force Acquisition Logistics Center

(AFALC), AFLC provides the deputy program manager for logistics (DPML) to most SPOs.

(1) **Air Logistics Centers (ALC).** The prime ALC provides reliability and maintainability (R&M) engineers to aid in conducting the R&M evaluation. The prime ALC also provides test team personnel to conduct logistics supportability evaluations. ALC personnel needed to support T&E must be specified in the TPO. The prime ALC, in conjunction with the using command and based on the software maintenance concept, will provide software evaluators to assess the supportability of the system software.

(2) **Deputy Program Manager for Logistics (DPML).** The DPML, located at the SPO, manages the integrated logistics support (ILS) program and ensures logistics issues are adequately addressed during system acquisition. The DPML is an excellent source of program-specific logistics information.

d. **Using Command.** The using command (e.g., Tactical Air Command) provides system operational maintenance personnel for the test team as specified in the TPO. The using command is the lead activity for developing operational requirements against which AFOTTEC evaluates the system.

e. **Air Training Command (ATC).** ATC provides personnel, when specified in the TPO, to conduct system training evaluations.

6-3. Roles of Test Participants:

a. **Test Director.** A test director at the test location normally has execution authority for AFOTTEC-conducted OT&E programs. The test director will be supported by AFOTTEC headquarters elements and an AFOTTEC detachment, if applicable. Within the test team, the deputy for logistics evaluation reports to the test director and is responsible for all aspects of logistics evaluation. Similarly, the deputy for software evaluation reports to the test director and is responsible for evaluation of system and support software. Figure 6-1 depicts typical relationships. The headquarters often provides logistics analysis support to the test team for developing and running simulation models and other sophisticated analyses. Similarly, headquarters software personnel may administer software questionnaires and provide other support.

b. HQ AFOTTEC:

(1) **Logistics Evaluation Manager.** During

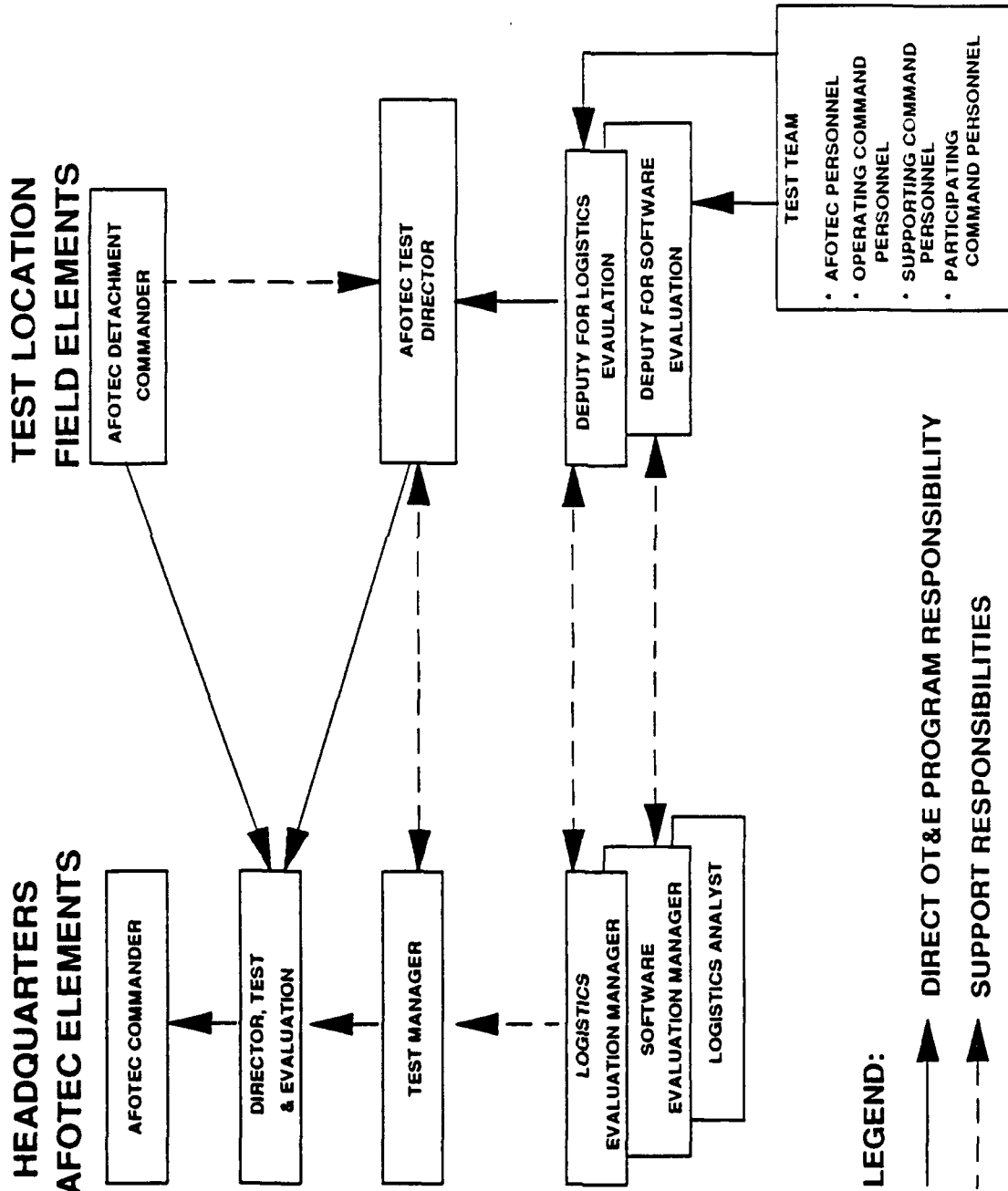

Figure 6-1. OT&E Program Management Relationships

execution of test programs, the logistics evaluation manager's role generally becomes that of a test monitor. The logistics evaluation manager maintains liaison with the test team deputy for logistics evaluation, determines progress of the test, and provides assistance, as required; maintains contact with the using command logistics point of contact, the DPML, and the ALC system/item managers, as required; makes periodic visits to the test site to stay current with and ensure proper progress of the test activity; and schedules internal test progress reviews, updates LG EIS, and processes documents for comment, as necessary.

(2) **Software Evaluation Manager (SEM).** The software evaluation manager maintains liaison with the test team deputy for software evaluation, providing assistance, as required; maintains contact with the using command and SPO software points of contact and the ALC software support manager, as required; and makes periodic visits to the test site to administer software evaluation questionnaires and to monitor the progress of the test. Before arrival of DSE, the SEM performs as the DSE. Also, the SEM is the software expert on the HQ AFOTTEC TSG.

(3) **Logistics Analysis Manager.** The logistics analysis manager is the principal logistic analysis advisor to the test support group (TSG) and the test team. Analysis includes evaluating key program issues and applying a structured analytical process to test design, execution, and reporting. The logistics analysis manager provides expertise in the disciplines of statistical inference and sample sizes, formulates mathematical and simulation models to address critical operational issues for OT&E and specific test objectives, and works closely with the test team deputy for logistics evaluation to ensure data are properly collected, processed, and analyzed.

c. Detachment. Detachments are comprised of several test teams at a common location in order to achieve economies of scale by sharing administrative support functions, monitor MAJCOM-conducted OT&E, and perform other activities as specified in AFOTTECR 55-43, AFOTTEC Sup 1.

d. Test Team. The formal test team organization should be shown in the test plan. The test director and the deputies for logistics and software evaluation may augment or refine the organization once the team is formed. The test team conducts detailed test planning before test start. After the team is established, detailed working procedures and responsibilities for team members must be determined. The test plan

and test team procedures may change during the course of the evaluation, based on the findings of the test team or changes to critical issues. These changes may or may not be formal, but they must be coordinated between the test team and HQ AFOTTEC in all cases.

(1) **Deputy for Logistics Evaluation (DLE).** The DLE evaluation is responsible for executing logistics portions of the test plan and maintaining liaison with the HQ AFOTTEC logistics evaluation manager using the command logistics points of contact, the DPML, and the ALC system manager. Reporting responsibilities include notifying the logistics evaluation manager of the status of suitability testing and writing the suitability portions of the final report. The deputy for logistics evaluation may also be tasked with managing the OT&E aspects of the service reporting system.

(2) **Deputy for Software Evaluation (DSE).** The DSE is responsible for executing the software portions of the test plan and maintaining liaison with the HQ AFOTTEC software evaluation manager, the using command and SPO software points of contact, and the software support facility manager.

(3) **Logistics and Software Evaluators.** Test team logistics and software evaluators, regardless of their basic unit of assignment, are under the operational control of the test director and work for the deputy for logistics evaluation or the deputy for software evaluation, respectively. They may be assigned to the test team on either a temporary duty or permanent change of station basis.

6-4. Activating the Test Team:

a. Local Support Relationships. The HQ AFOTTEC staff will generally have arranged for resources to support the test before the test team arrives using host-tenant support agreements, memoranda of agreement, program introduction documents, etc. The test team must carefully review these documents to ensure all required resources are provided.

b. Training:

(1) Test team personnel should be scheduled to attend applicable type 1 training (factory system training) en route to their test team assignment, if possible. If en route type 1 training is not feasible, they should attend as soon as possible after reporting to the team.

(2) HQ AFOTTEC has a formal 1-week OT&E course which is appropriate for test team management personnel. The deputy for logistics evaluation, deputy for software evaluation, and other selected senior logistics

evaluators should schedule their attendance for this course through their test director, AFOTTEC/TET, or their logistics evaluation manager.

(3) HQ AFOTTEC/LG3 offers a series of general suitability courses which can be presented at the test team location or at HQ AFOTTEC dependent on cost effectiveness. The topics available range from a general suitability overview to more detailed subjects such as reliability growth analysis and nuclear service reporting. These courses may be requested and scheduled through the logistics evaluation manager.

(4) Informal training and indoctrination will be provided to the test team by the headquarters logistics evaluation manager, analyst, and software evaluator, as required. This indoctrination should:

(a) Acquaint the logistics team members with the background of the test program, the test schedule, and the key milestones of the test in relation to major decision points.

(b) Provide a clear understanding of the test purpose, the test objectives, the defined operational and maintenance concepts, and the basic concepts of operational suitability test and evaluation.

(c) Ensure test team members understand the organization of the test team, the chain of command, their role on the team, and to whom they are responsible.

(d) Ensure test team members understand the procedures for interaction and coordination with other agencies, organizations, and commands.

(e) Ensure test team members understand the data management plan and their responsibilities in its execution. They must understand their special role as evaluators as well as maintainers and should dry-run data-related activities such as joint reliability and maintainability evaluation teams (JRMET) and SR prioritization boards before test start.

(f) Ensure test team members understand the meaning of restricted handling of source selection sensitive data LAW AFR 70-15, Formal Source Selection for Major Acquisitions.

(g) Ensure test members understand security aspects of the program.

6-5. Review of Program Documentation:

a. **Test Plan.** The test team should review the test plan (if possible, in conjunction with the TSG) to acquaint themselves with the critical issues, test objectives, and associated measures of effectiveness. They should review test scenarios and methods to ensure they can accomplish the objectives.

The test plan should be viewed as a living document. If a change is required to the test plan, the test team should contact the test manager. Test plan changes must be thoroughly coordinated and approved by HQ AFOTTEC. The test team does not have the authority to unilaterally change the test plan.

b. **Test Program Outline (TPO).** The test team should review the TPO to ensure sufficient resources have been requested to accomplish the test and the resources have been or will be acquired.

c. **Contract.** Review of the contract may provide the deputy for logistics evaluation insight into the data system which will be used in the test. Of particular concern are limitations that may occur because of either contractual requirements or omissions of requirements which are required to support OT&E.

d. **System Operational and Maintenance Concepts.** The test team should review these documents to provide insight when evaluating and interpreting the test results.

e. **Threat Analysis.** Review of the threat analysis should provide insight into the adequacy of the test scenario. The scenario or test events may need to be modified to address logistical efforts within the threat environment, such as operating in chemical protective gear.

f. **Integrated Logistics Support Plan (ILSP).** The test team should review the ILSP to acquaint themselves with program acquisition logistics requirements and strategy. This information will aid in understanding the test environment and in evaluating test results.

g. **Other Documents.** The following documents provide further insight into the program and test environments:

(1) Program management directive (PMD).

(2) Program management plan (PMP).

(3) Mission need statement (MNS).

(4) Operational Requirements Document (ORD), and requirements correlation matrix (RCM).

(5) Test and evaluation master plan (TEMP).

(6) Decision coordinating paper (DCP).

h. **Document Revisions.** The DLE/DSE should notify the logistics evaluation manager of any suitability-related inconsistencies, inaccuracies, and testing problems discovered during the document review process. If the logistics evaluation manager cannot solve the problem, the test manager, in concert with the TSG and test team, will resolve these issues.

(3) Establish name and face-to-face contact with OT&E representatives in the using command, the supporting commands, the ALCs, the DPML, and above all, in your own test team.

(4) Attend program reviews, working groups, and integrated logistics support management team (ILSMT) meetings to ensure OT&E issues are adequately addressed and to remain informed of program status and planning.

(5) Coordinate inputs to the agenda of any of the above meetings to ensure a thorough understanding of the AFOTTEC position.

(6) Keep each other (logistics evaluation manager and deputy for logistics evaluation) informed of progress and problems.

(7) Maintain a contact file with relevant information about the contact: person, place, subject, problem nature, when contacted, results, further action required, etc.

b. Preparation for Test Execution:

(1) Logistics evaluation managers, analysts, and software evaluation managers must take the lead in ensuring the DLE, DSE, and others are aware of and receive available OT&E and operational suitability training.

(2) The test team deputies should each assemble their personnel, analyze the test plan, determine the most effective manner to accomplish the test, and create/expand detailed test procedures. Using a copy of the test schedule, ensure test events are tied to specific test objectives.

(3) Test team deputies should avoid becoming too involved in day-to-day details of test support to the detriment of managing their overall test and evaluation requirements. Avoid becoming an action officer. The DLE should not become the test supply or mobility officer at the expense of the OT&E mission. The DSE is not the Word-Perfect expert or Z-248 guru on the test team.

(4) Keep the interfaces working between the test team and HQ AFOTTEC.

(5) Test teams should be given a great deal of flexibility in achieving test objectives.

(6) Agreements to provide test support, e.g., with the host base commander, should be in writing.

(7) Contractor data may not be complete or may be in a format unfamiliar to the logistics evaluators. The test team must identify and compensate for differences in definitions in the OT&E data base.

(8) Discussions with the contractor can be extremely sensitive. The test team should always provide advance notification to the SPO of any involvement with the contractor. AFOTTEC has no authority to direct contrac-

tors.

(9) The best single source of information on testing is AFOTTEC personnel who have done it before. No formal data source or training program can provide as much guidance as experienced personnel.

(10) Bring the test team deputies on board early, preferably for final review of the test plan at HQ AFOTTEC. Follow them with a small cadre (e.g., maintenance officer and data collectors) well in advance of test execution. Get the whole test team in place and trained by the start of test. However, keep abreast of test schedule slips, and do not have the bulk of the test team on board too early.

(11) The test team should dry run the JRMET and SR prioritization boards (at least 30 days before test start) to mitigate inevitable problems with board procedures and data review.

(12) Bases operationally oriented will have a different perception of the test than bases where tests are routinely conducted. The test team must explain the mission, emphasis, and procedures of OT&E to base managers.

(13) Test team management should review applicable lessons learned from the OT&E Lessons Learned Data Bank. Do not repeat the mistakes of your predecessors, but capitalize on their observations.

c. Active Testing:

(1) Data collection requires much discipline within the test team to collect complete, accurate suitability data.

(2) Test team coordination with the contractor's maintenance activity will be more difficult if the contractor has no central maintenance control office. Collection of quantitative and qualitative maintenance data will require the test team to coordinate with individual maintenance shops.

(3) The DLE may be able to accomplish the suitability evaluation easier if his or her office is physically close to the maintenance activity.

(4) Careful quality control is required in data processing to ensure data are not lost during input or sorting. Compare sample size at input and output.

(5) Differences between the test environment and operational environment require careful subjective analysis. Rationale used to extrapolate test environment results to the operational environment should be thoroughly documented in the detailed test procedures.

(6) Maintenance personnel filling a dual role of equipment maintainers and logistics evaluators tend to forget test priorities and acquire a vested interest in making the test

6-6. Key Meetings:

a. **Program Meetings.** During the OT&E planning process, members of the TSG attend and participate in program-related meetings (e.g., test planning working group (TPWG) meetings, program design reviews, and ILSMT meetings). However, after the test team has been activated, test team members should also attend these meetings. The test team should participate in program-related meetings to ensure they are fully informed of program status and planning.

b. **OT&E Meetings.** Aside from meetings scheduled by the test director, test team and suitability TSG members may participate in JRMETS and materiel improvement project review boards (MIPRB). JRMETS are discussed in chapter 7. MIPRBs are discussed in paragraph 6-8.

6-7. Active Testing:

a. Test members should direct activities during active testing toward achieving test objectives and producing a meaningful final report. Place emphasis on collecting and analyzing data required by the test plan and the detailed test procedures. The key to success is review and analysis of data as they are collected, particularly during long tests. Without this review, problems in the data collection process may be overlooked until it is too late to recover and major test objectives become unachievable.

b. Operational suitability data may be divided into two categories—quantitative and qualitative. The collection of quantitative operational suitability data is frequently tied to operational effectiveness test events. As a result, logistics evaluators must work closely with effectiveness evaluators to ensure logistics data are collected on all test events. Collection must be followed by a detailed audit to ensure all the required data were collected and correct coding was used. Analysis of the data should be accomplished by logistics evaluators and the JRMETS. Calculation of measures of effectiveness should occur as early as possible to verify the data collection and reduction processes and allow early correction of inadequacies. Additionally, MOEs should be updated periodically to identify trends and areas of concern and to ensure the continued adequacy of the data collecting process. Test data analysis should also begin as early as possible and continue throughout the test. This analysis should be aimed at identifying trends and deficiencies and at determining their causes.

c. The collection of qualitative operational suitability data must be carefully planned and executed to ensure all data are collected

and analyzed before the test is over. Qualitative data collection involves a wide range of activities which vary from the completion of questionnaires to the review of program office logistics planning documents. Regardless of sources, qualitative data may be thought of as opinions of one or more individuals. As such, care must be taken to ensure objectivity is maintained throughout the process of collecting and analyzing these data. While some subjective analyses may be conducted toward the end of testing, they should be done in time to allow a detailed analysis of significant findings.

6-8. Service Reporting (SR):

a. A primary OT&E function is to identify and report deficiencies that impact the operational suitability and operational effectiveness of the weapon system. Early identification of deficiencies provides the opportunity to fix problems at a lower cost.

b. The test team must develop rigorous procedures to identify, verify, report, and track deficiencies. Technical Order (TO) 00-35D-54, USAF Material Deficiency Reporting and Investigating System, and AFR 55-43, provide guidance for establishing these procedures. Deficiencies reported should not be limited to items for which the contractor is responsible. For example, if the system being evaluated consists of government-furnished equipment (GFE) and contractor-developed equipment and a deficiency is discovered that relates to the GFE, the test team should submit a service report.

c. The test director is responsible for the SR program and identifies who will perform duties related to monitoring all SR activities. The test team deputy for logistics evaluation may be tasked with handling the administration of the service reporting process including representing the Operational Test Agency (OTA) on MIPRBs and chairing SR prioritization boards. MIPRBs assign funding to the SRs. Close coordination with all affected agencies is required throughout the test. The test team should notify the program office and, if warranted, the contractor of identified and suspected system deficiencies.

6-9. Lessons Learned:

a. **Working Relationships.** Many things can be done to ensure effective working relationships. Among these are:

(1) Numbers and types of participating organization personnel necessary to support OT&E and the periods of time they are required must be specified in the TPO.

(2) Determine the formal and informal lines of authority in the program.

item operate. This can skew test data, especially where testers have higher skill levels than planned for the operational environment.

(7) Site Activation Task Force (SATAF). SATAF activity is not formally related to OT&E; however, information gathered during OT&E can be of assistance to a SATAF. AFOTTEC may render assistance to SATAFs by placing them on the information list for SRs and other test reports that might be of interest. AFOTTEC can provide additional assistance by answering questions which may arise at SATAF meetings.

(8) AFOTTEC/LG action officers should maintain frequent (daily) contact with the test team. Items of interest should be forwarded to the director of logistics, depending on urgency. Timely submission of trip reports is a must.

d. Service Reporting:

(1) Transmit only those deficiencies which are thoroughly screened and validated by the team and test director. Inaccurate, trivial, or improperly documented SRs degrade the team's credibility and needlessly congest the SR pipeline.

(2) Track every SR until the reported deficiency is resolved or the test is over. Establishment of material improvement project (MIP) by the SPO or the subsequent establishment and funding of an engineering change proposal (ECP) are not sufficient grounds to close the books on an SR. SRs must not be closed until a fix has been implemented and verified or the MIP review board unanimously agrees on closure.

(3) Consider using an automated test team SR tracking system for large programs. In one test, the SPO loaded MIPs into an independent computer file to which the test team had access. HQ AFOTTEC/LG has a microcomputer-based SR tracking program available to generate and track test team-

initiated SRs.

(4) The SR system requires many man-hours. Do not underestimate the workload.

(5) Do not hold SRs and report them all at the end of the test. Deficiencies should be identified in a timely manner for corrective action. Timelines for submission and processing of SRs are specified in TO 00-35D-54.

(6) Do not assume deficiencies identified on a system still under a reliability improvement warranty will be corrected "free" by the contractor. Investigate this peculiarity carefully with the SPO and report any validated deficiency as an SR. Procedures for SR documentation of warranted items are specified in TO 00-35D-54.

(7) Be thorough in documenting the SR. The SPO action officer may not be familiar with the problem. Send pictures or videotape if necessary. Be prepared to provide an exhibit or sample of failed, poor workmanship, or nonconforming items.

(8) Work SRs before, during, and after testing. Get started early. Appoint an SR monitor on day one.

(9) Make sure everyone on the team knows (before test execution) the full details of the SR program, including filling out forms; researching the contract and part numbers, nomenclature, classification, downgrade instructions, etc.

(10) Establish and widely publicize ground rules for resolving differences of opinion on SR closures. SRs may not be unilaterally closed by the SPO or others if there are objections.

(11) Include SRs as an item for mission debrief/lessons learned.

(12) Give inputs to an assigned SR writer for the affected functional area. SR writers should (within a day or two, while memories are fresh) revise the initial version of the draft SR, if required, based on feedback from crews, data collectors, etc.

Chapter 7

MANAGING OPERATIONAL SUITABILITY DATA

7-1. General:

a. Data management is the process of identifying, collecting, processing, and disposing test-related data. The purpose of this chapter is to familiarize T&E personnel with data management and analysis, data collection and control, and common modeling inputs and responsibilities. It also provides a discussion of the logistics support analysis (LSA) program.

b. An AFOTTEC test team uses TSG/test team-developed methods for data management based on the test plan, test team resources, and the dictates of ongoing program events. OT&E test plans are reviewed to identify required data. It should then be determined whether the data will be collected by the test team or from the tests and activities conducted and reported by other organizations (e.g., contractors, development testers.) If the decision is to collect the required data from the tests conducted by others, testing and reporting plans of those agencies should be reviewed to determine whether data requirements will be satisfied with or without AFOTTEC test team participation. If it appears the data requirements will be satisfied, necessary coordination must be accomplished and the data collected and analyzed. Unless problem areas are identified which require analysis of raw test data, it is acceptable to use test and analysis reports from other agencies at the highest possible level of aggregation. If test team participation is required, they should develop and coordinate necessary plans and collect and analyze data. In those cases where data requirements cannot be satisfied, the test plan should be modified or data requirements reassessed.

c. AFR 800-18 charges the implementing command (normally Air Force Systems Command (AFSC)) with the responsibility of implementing data collection for measuring and evaluating R&M during development test and evaluation (DT&E) or OT&E programs and with establishing a joint reliability and maintainability evaluation team (JRMET) for major system acquisitions.

d. Suitability test personnel should normally use the following procedures:

(1) Specify the R&M data base in the AFOTTEC test plan. The data base systems below normally apply:

(a) Edwards AFB SEDS. OT&E programs supported by Edwards AFB R&M data

processing use the SEDS maintained by AFFTC/ENAR or 6520 Test Group.

(b) Eglin AFB SEDS. OT&E programs supported by Eglin AFB R&E data processing use the SEDS R&M data system maintained by Det 24, ASD/ENP.

(c) AFOTTEC OMNIVORE. OT&E programs not supported by the Edwards or Eglin SEDS use AFOTTEC's OMNIVORE/MICRO-OMNIVORE computer programs.

(d) Manually kept logs and videotape libraries.

(2) Requirements for computer time, programmer support, video recorders, instrumentation, and similar resources must be included in the test program outline (TPO).

(3) Unique operational suitability data system requirements will be coordinated with HQ AFOTTEC/TE through HQ AFOTTEC/LG to ensure the requirement is not met by current capabilities, new requirements comply with R&M standards, and new developments receive wide dissemination and appropriate use.

(4) Unique automated data processing requirements, such as data processing equipment or contractor support, should be coordinated with HQ AFOTTEC/RM through HQ AFOTTEC/LG.

(5) Test teams must participate on the JRMET. Normally, the primary representative is the deputy for logistics evaluation, assisted by the deputy for software evaluation, the R&M analyst/engineer, and maintenance personnel. While AFOTTEC is not bound by the JRMET's interpretation of the data, agreement is usually reached and a common data base is established for use by all participating agencies. In cases where agreement is not reached, the specific items should be coded in the common R&M data base for separate DT&E and OT&E analysis.

7-2. Data Management and Analysis Plan (DMAP). Reference AFR 55-43, for additional guidance.

a. The DMAP, which parallels the test plan in development, is the primary tool to ensure required data are identified, recorded, collected, reduced, processed, verified, analyzed, and evaluated to support each test objective. It is developed jointly by the TSG and test team. The DMAP is designed to be a working document used in the actual conduct of a test and is not intended for external coordination. It must provide a

flexible means of updating test data requirements and test philosophy to meet the needs of the test program. It should address:

(1) Dissemination of data between different locations.

(2) Data processes to avoid duplication of effort.

(3) Focal points and responsibility centers for data management.

(4) Who will collect the data, what they are to do with them, where they go, what will be done next, etc.

(5) Calculations and data processing equipment to be used. The analysis techniques and evaluation procedures should spell out who will do what with which technique.

(6) Disposition policies for all test data describing the exact procedures and media to be used in storage.

b. The body of the DMAP is generally organized by test objectives, but for a complex test it may be organized by test phases or test environment. As an extreme example, a multiservice test may require the collection of data at different test sites, transportation to a control data processing agency, and extensive quality control to ensure compatibility. These requirements may dictate the need for a separate data collection plan coordinated through participating agencies.

c. The DMAP generally begins with a synopsis of the test, description of the test articles, test environment and scenario test objectives, models which may be used for analysis, contractor involvement, and any other factors which are expected to impact data management. Some estimates of the volume and diversity of the test data must be developed as a starting point for data management because these will affect the choice of data systems.

d. The DMAP should address data requirements which differ from common practice or require special attention from the test team. An operational suitability evaluation generally uses established data system, procedures, and definitions, e.g., SEDS or core automated maintenance system (CAMS). However, some test objectives, such as dormant reliability or built-in test (BIT) effectiveness, may require nonstandard data items. The DMAP should specify in greater detail the data requirements, procedures, and definitions for these objectives. The DMAP should also address any data collection requirements unique to the test.

e. Special attention must be given to the use of contractor data. Data requirements must be coordinated with the SPO at the earliest possible date to ensure they are

specified by contract. Where possible, develop specific techniques to ensure the contractor data are representative of actual conditions.

f. The DMAP should include provisions for maintaining the data system. Experience from several previous test programs has shown operational data processing packages do not always work as prescribed. Additional programming support may be required to satisfy the MOEs. Other test programs have generated additional test objectives as the program progressed. These new requirements may also need programming support. Latent errors may surface in a data analysis program which has been operational for an extended period. Programming support for data system maintenance is not generally available within a test team; therefore, the support must be obtained from another agency. Programming support should continue throughout the test program if the data processing system is contractor supplied. For any specially developed data programs, system maintenance requirements should receive special attention and should be specified in detail in the DMAP.

g. The DMAP should carefully document intended service reporting (SR) procedures. SR screening points, exhibit holding areas, prioritization methods, prioritization board membership, etc., must be carefully thought out and specified. If the deficiency and enhancement analysis and ranking technique (DART) is to be used to prioritize SRs, rating areas and weights must be formulated and coordinated with the using command prior to test start. Coordinated rating areas, weights, DART forms, and prioritization board procedures should be specified in the DMAP. A "DMAP dry run" should be conducted jointly by the TSG and test team before the test readiness briefing.

7-3. Air Force Data Systems:

a. **Introduction.** This section discusses automated data systems that may support suitability OT&E. Data collection is only the first step. The test team must then collate and evaluate the data. For major programs with large quantities of data, use of automated systems may reduce the amount of manual analysis of test data required. Some current data systems are as follows:

(1) Core Automated Maintenance System (CAMS). CAMS is the Air Force's standard system for collecting maintenance data for operational Air Force systems. CAMS was primarily designed to support base-level maintenance managers in comparing performance of equipment and personnel with sched-

uled requirements and in identifying trends. Output products from CAMS are used in supporting decisions on equipment modifications and provisioning. Products are also available to provide quantitative data for failures/discrepancies, maintenance actions, and maintenance man-hours for a specific calendar period.

(2) System Effectiveness Data System (SEDS). SEDS is an AFSC reliability and maintainability data acquisition, storage, retrieval, reporting, and analysis system developed primarily to be used for test purposes.

(a) There are two primary versions of SEDS. One is maintained by Air Force Flight Test Center (AFFTC), the other by Det 24, ASD/ENP. Both use AFSC Forms 258, Maintenance Discrepancy/Production Credit Record, and 258-4 (four-part copy). The ASD/ENP SEDS is a version of AFFTC SEDS developed inhouse by ASD/ENP, Eglin AFB. It is managed by the Directorate of Manufacturing and Supportability. A major difference in the ASD/ENP version of SEDS is it can track system or subsystem operating time independent of aircraft time to conduct reliability analyses. ASD/ENP SEDS can also be used to conduct reliability growth analyses routine. Time to failure is tracked in the ASD/ENP version of SEDS but not in the AFFTC version.

(b) SEDS has many common elements with the CAMS, but it is more useful because it provides a capability for a narrative presentation of discrepancies and corrective actions, delay codes, required Air Force specialty codes, ground support equipment data, diagnostic data, and technical order data. During OT&E, AFOTTEC has a need to obtain extensive information on a system in order to determine the degree to which it can be placed into field use. Once fielded, some data elements are not necessary and hence not tracked by CAMS.

(3) Maintenance Management Information and Control System (MMICS):

(a) MMICS was designed to provide real-time management information to base-level maintenance managers. MMICS includes a wide variety of control and reporting routines to reduce the need to prepare management documentation manually. Air Force Manual 66-278, MMICS Users Manual, volumes 1 through 3, with the implementing directives, provides complete instructions for MMICS use and descriptions of the output products. For the purposes of logistics evaluation during test and evaluation, the primary MMICS functions of interest are the on-line reporting of equipment inventory and

status fully mission capable (FMC), partially mission capable (PMC), and not mission capable (NMC). This function permits input to the computer of inventory and status changes as they occur by means of terminals located in the maintenance complex. The output product (Aerospace Vehicle Status Report) provides a status summary report by reason and cause for a period of 99 days, status distribution by day, and average distribution time for 31 days, or a combination of status summary and distribution of 31 days.

(b) In addition to the Aerospace Vehicle Status Report, MMICS contains segments to manage time compliance technical orders, mechanized equipment records, job standards, work unit codes, operational events, delayed discrepancy file, maintenance administration, and training.

(4) Equipment Inventory, Status, and Utilization Reporting Systems. AFR 65-110, Aerospace Vehicle and Equipment Inventory, Status, and Utilization Reporting System (AVISURS), forms the basis for developing the Air Force programming documents and related budgets and manning requirements. It can also aid the operational suitability test planner in several ways. For a system that is under the reporting provisions of AFR 65-110 during test, the reporting system becomes a detailed historical record of availability and utilization rates. For reporting purposes, once the initial inventory files have been created, reports are submitted only when changes in inventory or status occur and/or when the equipment is used. Inventory, status, and utilization reports are rendered daily, covering the preceding 24-hour period. The maintenance activity reports inventory and status while operations report utilization. Exceptions to these procedures apply to communication-electronic-meteorological (CEM) equipment, which uses AF Form 264 (MMICS Job/Status Document) to report inventory and status, and to the on-line inventory and reporting procedures under MMICS. The system can be used for subsystems when special arrangements have been made.

(5) Standard Base Supply System (SBSS):

(a) The SBSS is an automated inventory accounting system, designed to provide timely support to base-level activities. The SBSS uses a computer for storage and maintenance of records and for generation of management reports. AFM 67-1 provides an overview of the SBSS.

(b) SBSS has the capability to process demands and receipts, compute levels of

supply, and control inventories. The system produces numerous reports on a scheduled and an as-required basis which are designed to assist managers at all levels in the discharge of their responsibilities. Of course, SBSS data are only useful when supply support is organic. It is frequently not useful for IOT&E, when other supply measurement system must be developed.

(6) Common Data Extraction Programs (CDEP):

(a) The logistics composite model (LCOM) requires detailed information concerning the frequency of maintenance tasks and resource requirements. The frequency and resource requirements of scheduled maintenance tasks can normally be obtained from applicable technical orders. However, the frequency of unscheduled maintenance tasks and resource requirements are not readily available from any source. To solve this problem, TAC and the Human Resource Laboratory (HRL) developed computer programs which process CAMS (see AFM 66-279, Core Automated Maintenance System (CAMS)) base-level history tapes (ABD6DA). The output from the TAC program was frequency information for unscheduled maintenance tasks. The output from the HRL program was frequency of unscheduled maintenance tasks and resource information.

(b) To standardize LCOM methodology, the Air Force Maintenance and Supply Management Team (AFMSMT) produced a standard version of the data extraction programs. The logic from the HRL programs was used as the basis for CDEP. However, several enhancements were added to improve the utility of CDEP for a variety of applications.

(c) The base-level history tape (ABD6DA) contains maintenance data collection (MDC) data. These data are taken directly from AFTO Forms 349, Maintenance Data Collection Record, prepared by the maintenance technicians. As a result, the base-level tapes represent MDC data in the most elemental form. However, there is a large gap between the data requirements of LCOM and data contained on the base-level tape. Basically, this gap is created by the very detailed reporting procedures of the MDCS. The main function of the CDEP is to analyze MDC records and present them in a form compatible with LCOM networking methodology. Detailed instructions for use of CDEP are documented in the common data extraction program standard system user documentation report which AFMSMT, Wright-Patterson AFB, Ohio, writes and distributes.

(7) OMNIVORE/MICRO-OMNIVORE:

(a) OMNIVORE/MICRO-OMNIVORE is an AFOTEC-developed data retrieval and analysis system. The system enables the user to consolidate selected maintenance and operating time data collected in standard Air Force automated data systems and to perform detailed statistical analyses which are not available from existing standard systems.

(b) The system is currently implemented to accept data inputs from CAMS, MMICS, and SEDS. Proper use of OMNIVORE/MICRO-OMNIVORE requires some knowledge and familiarity by the functional user with the purpose and capabilities of these four systems.

(c) Reference AFOTEC operating instructions for additional guidance.

(8) Limitations of AFLC Products. Products from AFLC data systems can be of significant benefit for logistics assessments during test planning and conduct. However, the lack of timeliness limits their usefulness in preparing evaluation reports at the end of test. The AFLC reports are published approximately 60 days after the closeout date for each monthly or quarterly cycle. With final test reports due within 60 days after completion of test program (IOT&E/FOT&E), data from the last 2 months of operational testing would not be available for inclusion in the test report. The impacts of this data shortage on test reporting should be evaluated to determine usefulness of these products during OT&E.

b. AFOTEC Point of Contact. The AFOTEC point of contact concerning data collection and processing is the Logistics Studies and Analysis Division (HQ AFOTEC/LG4). Questions regarding selection of the appropriate data collection system and implementation during test should be directed to this organization.

7-4. Other Data Sources. During multi-service test, AFOTEC personnel may use US Army or Navy data systems, particularly if the Air Force is not the lead service. The following discussion identifies Army and Navy (including Marine Corps) systems:

a. US Army Data Systems. The two most widely used data base management systems within the US Army are System 2000 and MANAGE. In addition, the US Army uses reliability, availability, and maintainability engineering data bases to store and retrieve data. These data bases include reliability, availability, maintainability, and logistics (RAM/LOG); vehicle technical management system (VETMIS); tank-automotive integrated data base (TAIDB); common test data collection system (CTDCS); and

MANAGE.**b. Navy Data Systems:**

(1) Naval Aviation Maintenance and Material Management System (Aviation 3-M). The Naval aviation maintenance and material management system is a comprehensive system which combines availability, reliability, maintainability, and logistics supportability into a single data system. The 3-M system uses labor hours from the man-hour accounting (MHA) system, maintenance activity from the maintenance data reporting (MDR) system, mission-capable status from the subsystem capability impact reporting (SCIR) system, ground support equipment inventory and utilization from the ground support equipment (GSE) reporting system, supply support from the material reporting (MR) system, and training device utilization and support from the training device support data (TDSSD) system. The bulk of the input data is recorded on visual information display system/maintenance action form (VIDS/MAF) which contains maintenance and supply data.

(2) Navy Ships' Maintenance and Material Management System. The Navy ships' 3-M system is analogous to the aviation 3-M system. It contains maintenance data collection systems for both active and mothballed equipment, a maintenance data processing system, and an alteration management system for shipboard configuration control. AFOTTEC OT&E may encounter the surface ship system in evaluating such systems as CEM equipment or cruise missiles. The shipboard 3-M system compiles maintenance actions, labor hours, and equipment status to produce reports of work center production, system and component maintenance summaries, and other maintenance management aids.

c. Government-Industry Data Exchange Program (GIDEP). The GIDEP is a cooperative activity between government and industry participants to automatically exchange certain types of technical data essential in the research, development, production, and operational life cycle of systems and equipment. The GIDEP maintains specialized data banks which are available to government and industry.

d. Defense Logistics Studies Information Exchange (DLSIE):

(1) DODI 5154.19, Defense Logistics Studies Information Exchange (DLSIE), formed the basis for its current charter. The Air Force implementing regulation is AFR 400-51, Operation of the Logistics Research Program.

(2) DLSIE collects, organizes, stores, and disseminates information pertaining to logis-

tics studies, models, management information, and related documentation which may be of benefit to the DOD logistics management and research community. By reviewing the DLSIE collection, logistics research activities can avoid spending defense dollars on research that has already been done.

e. Defense Technical Information Center (DTIC):

(1) DTIC, a primary field activity of the Defense Supply Agency, is the central banking institution for DOD's collection of research and development information in virtually all fields of science and technology.

(2) DTIC has the mission to exploit the contents of its collection to answer three basic questions relative to the research, development, test and evaluation (RDT&E) program of DOD:

(a) What research is being planned?

(b) What research is currently being performed?

(c) What results were realized by completed research?

(3) The AFOTTEC historian (HQ AFOTTEC/RS (Research Services)) is the focal point for dealing with DTIC. HQ AFOTTEC/RS maintains a significant number of DTIC documents and periodically receives the catalog of new publications from DTIC.

f. Military Specification, Handbooks, and Standards:

(1) A logistics evaluator will frequently need access to military specifications (MIL-SPEC), handbooks (MIL-HDBK), and standards (MIL-STD). These documents are referenced in contracts, requests for proposals (RFP), system specifications, and integrated logistics support plans (ILSP).

(2) HQ AFOTTEC/LG has established a technical library which contains some of the most commonly used documents. If you need access to documents not contained in this library, contact HQ AFOTTEC/RS.

g. AFOTTEC OT&E Data Bank. HQ AFOTTEC/RS manages the AFOTTEC OT&E data bank. The data bank is a research and reference service supported by microfiche documents, technical paper, studies, analyses, test plans, evaluations, policy papers, and specific program documents. Several hundred hard-copy reports from a variety of sources are also on hand.

7-5. Logistics Support Analysis Program:

a. Analytical Efforts. The analytical efforts which support the integrated logistics support (ILS) process are referred to as logistics support analyses (LSA). A data system called an LSA record (LSAR) captures

the data generated during LSA.

b. Planning and Execution. LSA is important to suitability test planning and execution because it is the major source of data used to develop the support system. A series of 15 LSA tasks and 77 subtasks detailed in MIL-STD 1388-1A, Logistics Support Analysis, can be selectively chosen for the LSA effort based on unique program requirements. The selected tasks will produce detailed maintenance task information which is useful in the OT&E logistics analysis effort. It also shows the detailed factors on which the support system is based. These can be used to reveal potential problem areas. LSA inputs and outputs are summarized in figure 7-1.

c. Primary Objectives:

(1) The analysis identifies the qualitative and quantitative logistics support requirements. A systematic, comprehensive analysis is conducted on an interactive basis throughout the system's life cycle. Initial analyses evaluate the system's design and operational parameters and estimate support

costs. During the development phase, maintenance tasks are defined and the logistics support requirements are identified. During the operational phase, proposed changes and modifications are evaluated to identify their effect on maintenance and support.

(2) The analysis influences the system's design for logistic considerations. The initial analysis effort evaluates the effects of design alternatives on support costs and operational readiness. Known scarcities, constraints, or logistics risk are identified, and ways of overcoming or minimizing them are developed. During FSD, the analysis is oriented toward assisting the designer in improving supportability, ease of maintenance, and ensuring the logistics infrastructure is developed and in place to support the fielding of the system.

(3) The analysis communicates requirements and integrates the elements of logistics support into a logistic support system. The LSA program establishes a communication link between the hardware design and ILS functional organizations through the LSAR.

INPUTS

- o Operational and maintenance requirement
- o Item reliability and maintenance characteristics
- o Task analysis summary
- o Maintenance and operator analysis
- o Support and test equipment or training description and justification
- o Facility description justification
- o Skill evaluation justification
- o Supply support requirements

OUTPUTS

- o Direct annual maintenance and operator man-hours by skill and specialty and level of maintenance
- o Reliability and maintainability summaries and analyses
- o Facility requirements summary
- o Support equipment requirement maintenance level/WUC
- o Special tools list
Requirements for special training devices
- o Requirements for facilities
- o Personnel and skill summary
Training task list
- o Provisioning data

Figure 7-1. LSA Inputs and Outputs

LSA is a source of data for the system design effort in the form of suggestions for improving the reliability, maintainability, logistics supportability, and ease of maintenance. The LSAR provides data for risk analyses, effectiveness studies, design and logistics support tradeoffs, and life cycle cost analyses.

d. Process. The contractor performs the LSA by applying the guidelines of MIL-STD 1388. The LSA process is iterative, beginning in the concept exploration phase with identification of support constraints for the system. The emphasis shifts from one analysis task to another as design progresses and data requirements increase. For example, in the early development stages, when design requirements are not well-defined, the analysis is directed toward identifying and establishing parameters for support functions at a system/subsystem level. After hardware configurations are defined, the analysis effort becomes more comprehensive and is directed toward the line-replaceable unit (LRU) or piecepart level. Well before deployment, the analysis concentrates on the impact on the supply system and maintenance organizations and develops detailed support requirements.

e. LSAR:

(1) The LSAR is a medium for systematically recording analysis data. The LSAR may be used on any program, regardless of size or complexity. The LSAR may be automated or nonautomated. The formats and data element definitions for automated LSAR as specified in MIL-STD 1388-2A, Logistics Support Analysis Record, DOD requirements form may be amended, supplemented, or altered with procuring activity approval to tailor them to program variations. The procuring activity must specify which data elements are required for the particular application.

(2) Data provided by the procuring activity, generated by coincident engineering requirements, and derived through the LSA are input to a standardized LSA automatic data processing (ADP) program through input data sheets. These input data are used by the ADP program to generate automated LSARs. Data sources for selected blocks on each input sheet may be clearly indicated by the use of a coding system. These data sheets, structured for a particular acquisition program, will be filled in as data become available. Such data sheets also act as checklists to ensure the analysis provides adequate visibility of logistic support resource requirements at all levels of hardware indenture.

(3) LSARs, which are outputs from data accumulated in the LSA data base and LSA

tasks, may be of varying types depending on the individual acquisition program. Some records will provide working data to contractor personnel responsible for some of the coincident programs affecting the LSA, e.g., human engineering; package, handling, storage, and transportation; technical data; and personnel and training. Other records may be generated in direct response to data item descriptions called out on the contractor data requirements list (CDRL).

7-6. Combining DT&E and OT&E Data:

a. An R&M data base separate from the DT&E agency is undesirable. AFR 800-18 places the responsibility for implementing R&M data collection systems during DT&E or OT&E on AFSC and requires the data base be available to all agencies participating in the test program.

b. A larger data base usually gives the logistics analyst more accuracy and more confidence in assessing system characteristics. However, there are pitfalls associated with larger, aggregate data bases. Any DT&E or OT&E data point which is placed in an aggregate data base must adhere to the applicable assumptions of the various models being used. Therefore, the development of a meaningful aggregate data base requires ground rules be established. Further, the developer, user, and tester must jointly review available data and decide what data to place in an aggregate data base. This is done by a joint reliability and maintainability evaluation team (JRMET). In multiservice/multiagency DT&E, where the Air Force is not the lead agency, a JRMET equivalent group should be used (i.e., the JRMET may be renamed as long as the basic purpose remains intact).

7-7. Joint Reliability and Maintainability Evaluation Team:

a. Air Force policy dictates test and operational data collection and analysis systems be complementary to each other to verify R&M performance throughout the system or equipment life cycle. The purpose of the JRMET is to review raw R&M data for accuracy, completeness, and contractual and operational relevance and to ensure data collection and analysis systems are complementary.

b. The implementing command is responsible for establishing a JRMET, writing the JRMET charter, and convening JRMET meetings. The system program office (SPO) chairs the JRMET, which is composed of representatives of the SPO, supporting command, operating command, DT&E test team, OT&E test team, other participating service/

agency representatives, and when appropriate, contractor personnel. The latter when present serves only in an advisory capacity.

c. Specific responsibilities of JRMET participants are specified in the JRMET charter. The charter also states policy for the joint use of R&M data, exchanges of R&M information, classification criteria for system related failures/faults, and administrative procedures for conducting JRMET meetings. The intent of having a charter is to avoid duplication of effort. If a charter is not established, the JRMET functions normally will be assigned within the SPO. AFOTEC/LG4 has several strawman JRMET charters for use when interfacing with the SPO.

d. The importance of a JRMET in OT&E cannot be over emphasized. JRMET meetings serve as an ideal forum for reviewing R&M data, becoming familiar with R&M terminology (see part three), obtaining common agreement on the use of R&M data, and ensuring data accuracy. JRMET meetings should be held periodically as R&M data are collected. Actual operational suitability T&E data reduction, analysis, and evaluation are normally not done at the meetings; rather, the DLE and logistics TSG personnel should accomplish this after each JRMET meeting to obtain estimates of applicable suitability MOEs. Release of any preliminary OT&E data analysis to agencies outside AFOTEC must be coordinated with the test director, test manager, and AFOTEC/PA as specified in the test plan.

e. Figure 7-2 is an example of a typical JRMET organization. AFOTEC involvement in the JRMET entails understanding the data for OT&E purposes and assisting AFSC and the contractor in understanding the data from an operational perspective. While AFOTEC is not bound to contractual interpretation of test data, agreements are usually reached to establish a common data base for use by all participating agencies. As test team DLE/DSEs may be unfamiliar with the JRMET organization and functioning, they should review the JRMET charter and convene a pre-JRMET consisting of test team logistics personnel, logistics TSG personnel, and appropriate operating command personnel. Air Force OT&E position with respect to the classification of R&M test data: The pre-JRMET is normally held one day before the formal JRMET meeting. Key questions to answer at the pre-JRMET/JRMET meetings are: Is a failure relevant or test peculiar? Did the failure critically impact the mission? Do computed values of R&M terms relate to contractual or operational require-

ments? Are values of R&M terms expressed as progress points on a growth curve or as mature system values? Was the failure software related? Has a failure-related service report been written, or is one needed?

f. In summary, the JRMET allows AFOTEC to reconcile data differences with the SPO or contractor. Other agencies also benefit by gaining the latest test information to use in updating logistics plans, logistics support analysis, initial provisioning estimates, and life cycle cost estimates. In addition, the integrated logistics support management team (ILSMT) or resident integrated logistics support activity (RILSA) interfaces with the JRMET to give the Air Logistics Center (ALC) updated system program management information.

7-8. Lessons Learned:

a. The DMAP should parallel development of the test plan and be completed before the start of active testing and should specify, for each MOE, the required data elements, data processing procedures, and analysis methodology. A "DMAP dry run" should be accomplished by the test team and TSG prior to the test readiness briefing. An inadequate DMAP will allow incomplete or inaccurate data to be entered into the data system; data collection procedures that are not compatible with the data system; or unacceptable delays in data processing, analysis, or reporting.

b. Early DMAP items requiring TBD action by the test team should be so identified. The DMAP must be flexible enough to accommodate lessons learned in test startup to changes to the acquisition program itself as well as corresponding changes to the objectives. Similarly, DMAP procedures have frequently required test team adjustment as they determine the effect test support or the environment has on the test conduct. Exercising the system with "dry runs" can uncover problems early and enable the test team to revise the DMAP or refine analysis methods or collection procedure while test time and resources are still available. Therefore, DMAP development should consider an iterative, cooperative, and continuous process among the test team, test managers, mission planners, data managers, and resources requirements planners.

c. Several tests have shown collected data may not always be as expected. This will be particularly true when OT&E is combined with DT&E and the evaluation is based, at least in part, on contractor data. Test data requirements should be coordinated as early as possible with the SPO, who has the authority to impose requirements on the

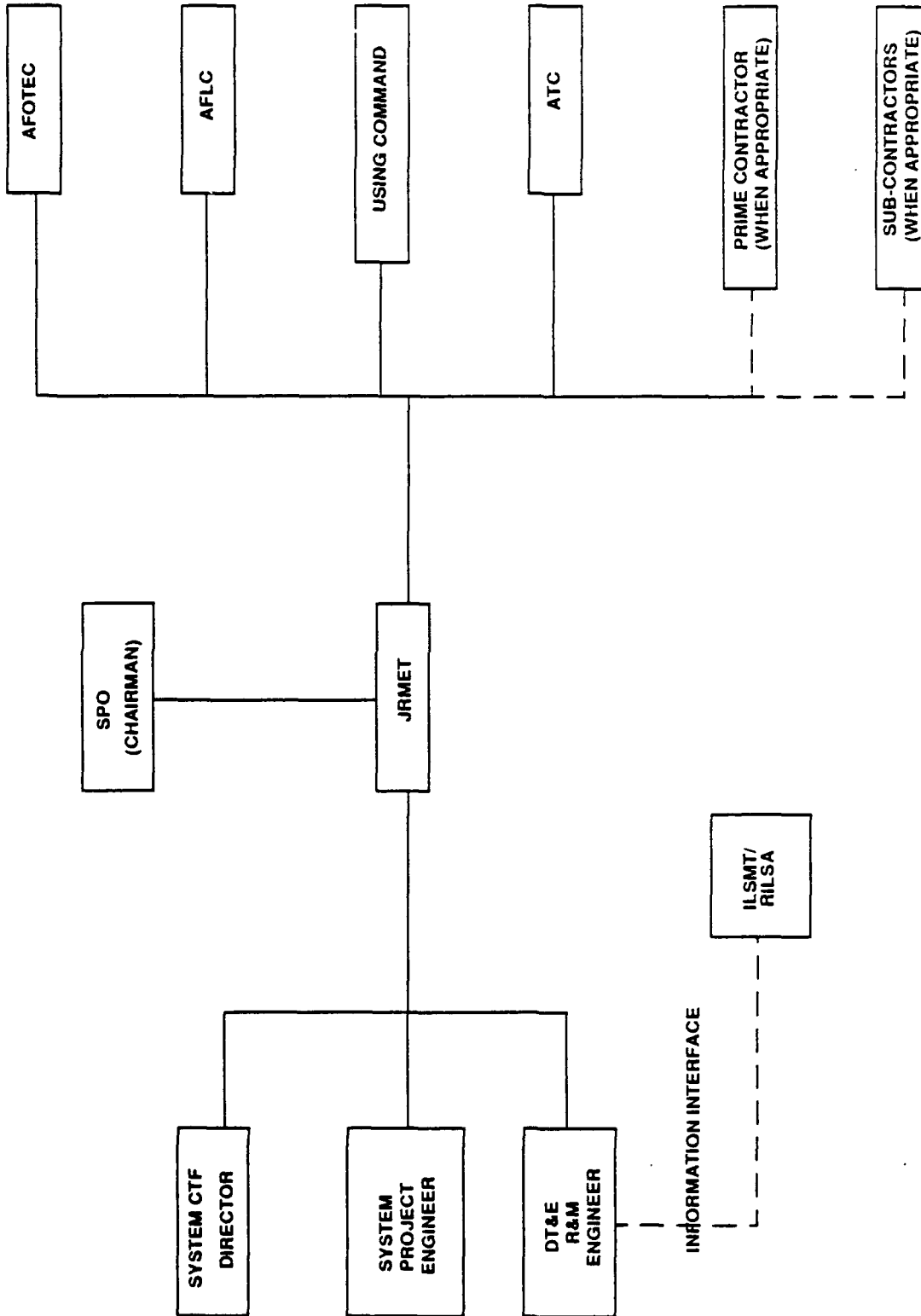

Figure 7-2. Typical JRMET Organization

contractor. This is also true when data are obtained from any other agency. Trial runs of the data should uncover any data deficiencies early enough to allow their correction.

d. The objective of the test team is to evaluate a system, not just operate it. All test team members should appreciate that data collection and processing is an essential part of this mission. Data collectors should be involved in the test planning and should be permanently assigned to the test team as data collectors.

e. The DMAP should address requirements for storage of classified material, particularly for a test that will be conducted in several locations.

f. Combined DT&E/OT&E should have a single data manager, normally within the DT&E organization. OT&E should also have a data focal point.

g. The DMAP should emphasize collecting data while they are still fresh in the tester's mind. The tester should conduct a prompt quality check to ensure accuracy and completeness.

h. To be effective, LSA has to be mutually understood by the SPO and the contractor. If this understanding does not exist, the contractor may just amass data for government use without using the data to influence system design or the development of the logistics support elements. Early and enlightened involvement of AFOTTEC logistics personnel, in addition to SPO logistics personnel, can help avoid this problem.

i. Audits of LSA data and methods are important. AFOTTEC is often in a position to help the SPO audit the contractor's LSA. Correcting LSA deficiencies (e.g., optimistic failure rates and faulty assumptions) early enables a more realistic support posture to be developed.

j. LSA is supposed to be an iterative process with early projections of R&M parameters updated with demonstrated values as the system develops. Some contractors are reluctant to make these updates. When this

happens, the SPO should be convinced to require the contractor to update the data base with test data as they become available.

k. When LSA data are to be the primary source of data for OT&E analysis (e.g., LCOM), review this data base early to identify deficiencies to ensure the data are usable. Potential areas for review include:

(1) Level of aggregation too high and detail lacking.

(2) Full-scale development (FSD) and production data mixed without distinction.

(3) Maintenance activities do not track through the data base (e.g., removals with no shop actions).

(4) Inconsistent data (e.g., MTBM greater than MTBF, system more reliable than subsystems, and subsystems more reliable than components).

(5) LSA reports difficult to read and reports poorly labeled.

(6) Data not current.

(7) Wartime scenarios not considered.

l. Understanding the purpose and use of the R&M data collected is fundamental to the proper functioning of the JRMET. A clear definition of failures and R&M terms is essential. In the past, problems have occurred because users simply misunderstood the intent of the definitions, and it was not uncommon for independent evaluations of a system to use different failure definitions, resulting in significantly different R&M values.

m. Scheduling frequent meetings of the JRMET increases travel costs, whereas infrequent meetings results in long, laborious reviews of reams of test data. The DLE can aid in balancing the frequency of meetings by notifying the SPO on the volume of test data collected and suggesting when a meeting should be called. Also, test planning should investigate the capability of having on-line adjudication of R&M data with JRMET meetings called only to resolve adjudication problems.

Chapter 8

DEVELOPING OPERATIONAL SUITABILITY REPORTS

8-1. General:

a. Discussions in previous chapters and AFR 55-43, establish numerous reporting requirements to ensure proper test planning, test execution, and communication of test results to decision makers. The TSG and test team need to be aware of these reporting requirements, the associated schedules, and report formats. In case of briefings, additional considerations apply, i.e., reserving a conference room, obtaining slide projector or viewgraph equipment, etc. HQ OI 11-6 establishes procedures for presenting briefings to the command section.

b. This chapter is not meant to outline briefing procedures such as know your audience, rehearse your presentation with peers, review your slides for typos and proper flow of information, etc. It is also not meant to teach you how or what to write; rather it explains the key test reports, gives considerations for presenting the operational suitability information, and provides some lessons learned.

c. A successful report requires an audit trail back through data analysis and reduction, raw test data, test planning assumptions, and limitations to the operational requirement. It also requires communication between the test team, the TSG, the SPO, and the supporting and operating commands.

8-2. Operational Suitability Reports:

a. There are four key reports:

(1) **Service Reports.** This report documents system deficiencies and/or enhancements discovered during OT&E. Procedures are explained in TO 00-35D-54 and AFR 55-43. The test team should submit service reports for both operational effectiveness and operational suitability deficiencies/enhancements.

(2) **Activity Reports.** These reports are messages between the test team and the TSG to communicate key test events completed/planned, problems associated with the OT&E, projected test completion date, changes in key test personnel, and OT&E specific information.

(3) **Interim Reports.** These reports provide current test results, test conclusion and evaluation information at designated points during test execution (midway through the test, at the end of a test phase, etc.). A message format is normally used. The Software Analysis Division software evalua-

tion managers (SEM), deputies for software evaluation, and software evaluation team members (SETM) conduct AFOTECP 800-2 series evaluations throughout the software development life cycle. The results of these initial assessments are written in software interim reports. These interim reports are staffed and provided to TE for distribution beyond AFOTEC. They are also used in support of the IOT&E final report.

(4) **Final Reports.** The final report presents results, conclusions, and recommendations from OT&E. A report/interim summary briefing, summarizing test results, may be required to support program decision milestones when insufficient time exists to prepare the final report. A separate data document is used to provide detailed test information.

b. Briefings are required for test planning reviews (TPR), final OT&E plan, test readiness reporting, test status reporting, operational assessments, interim summary reporting, and final reporting. The level of detail of these briefings will vary with the audience. In all cases, briefings will be coordinated with HQ AFOTEC staff. Additionally, the logistics and software evaluation managers (and/or the DLE/DSE) with support from the logistics analysis manager should be prepared to brief the AFOTEC Director of Logistics during interim/final report coordination cycle.

c. AFR 55-43 suggests the use of data documents to support the final OT&E report. AFR 55-43, AFOTEC Supplement 1 requires all important data (not included in the final report) be published in supporting data documents (SORD). HQ AFOTEC/LG staff has need of such detailed information/analysis for follow-on test planning, global studies, and various other reasons. Past experience has revealed that the information is often destroyed, lost, or not centralized. An SDD will be compiled for all logistics areas regardless of whether a document is created for other areas of test.

(1) The SDD provides nonjudgmental comments for in-depth documentation of test activities and supports the conclusions and recommendations contained in the final report. It is an objective-by-objective presentation of the detailed methodology used for test conduct and data analysis. The information should be sufficiently detailed to recreate the final report, if necessary.

(2) The format for the SDD should parallel that used for the final report. Areas addressed should likewise be addressed in the SDD. If there are no additional data available or required for input to the SDD, it should be so stated in the major heading paragraph.

(3) Logistic analysis inputs will present a detailed analysis approach to encompass reliability, maintainability, and availability. It will typically include reliability growth, mathematical models, or simulation models. The reliability growth discussion should include model justification and rationale for reliability growth and projections in general. The simulation model discussion should include model inputs and all model validation documentation. Also included in all discussions should be data collection methods, elements used, and where appropriate, statistical significance or risk.

(4) The nature of the logistic supportability evaluation precludes a definitive approach to determining items for inclusion in an SDD. Any or all of the logistics support elements may be looked at in the evaluation process, and in many cases "expert opinion" is the primary method of evaluation. Areas observed to make the evaluation should be addressed with supporting data if the scenario is not completely described in the final report.

(a) The prevalent kind of supporting data for logistics supportability areas will be resultant data from the administration of questionnaires or test team observations. Provide examples of the questionnaires used with a summary or matrix depicting the compiled data or responses. In-depth explanation of the methodology used in the administration of the questionnaires and analysis of the data is appropriate. In any case, the SDD is not meant to include all raw data. Rather, it is a compilation of data to support the evaluation results.

(b) Other kinds of support data include, but are not limited to:

1. **Task Evaluation Notes.** Summaries of notes from log books or documented observations which were referred to and used for determination of adequacy.

2. **Meeting Notes.** Action items from meetings which support final conclusions or demonstrate how conclusions were reached. An example is minutes from logistic support meetings which may demonstrate how information was obtained to reach decisions.

3. **Log Books.** Summaries of entries into test log books which reconstruct the scenarios and describe evaluation methodology.

4. **Trip Reports.** Descriptive accounts of tests conducted or meetings attended that may have provided information used in the evaluation.

5. **Photograph/Video.** Supportive photographic documentation is acceptable.

(c) Integrated diagnostic (ID) inputs will summarize the data that were available for evaluation and describe, in detail, how that information was used in the ID evaluation. If data were not used, explain why.

1. For the quantitative area, list the formula and the data elements that contribute to the calculation of that formula. Provide an explanation of how the data elements were categorized in order to provide an understanding of how the data were used to perform the ID evaluation.

2. For the qualitative areas of ID, include a copy of the questionnaires used and a summary of the results of the questionnaires. Any other information that supports the evaluation/assessments of the ID objectives/MOEs should also be included.

(5) Software analysis inputs will consist of the data, or appropriate references to interim reports containing the data, that substantiate the comments contained in the final report.

(a) Use the test plan objectives and measures of effectiveness as a guide for data collection.

(b) As applicable, attach all interim reports generated as a result of evaluations conducted in accordance with the AFOTECP 800-2 volumes (reference paragraph 8-2a(3)).

(c) Summarize the data collection methodology and results used to support the software maturity, life cycle process, software support resources assessments, and any other assessments not covered by interim reports.

8-3. Report Considerations:

a. **Test Team.** The test team DLE/DSE should:

(1) Begin preparing the final report on the first day of the test program.

(2) Be aware of the criticality of the final report and begin its preparation in a methodical manner to ensure reporting milestones are met.

(3) Pay particular attention to the executive summary (which is written last), the conclusions and recommendations, and specific test objective results. The executive summary should mirror the body of the report. The conclusions should complement the recommendations (i.e., if a test conclusion is "technical data to maintain the peculiar support equipment was not available," do not forget to include the recommendation "AFSC

procure technical data for maintaining the peculiar support equipment"). Lastly, the specific test results should describe the associated impact on the mission (e.g., "the computer's spare memory lacked sufficient capacity to support mission XXX. This caused loss of critical messages being relayed to the operator and forced the operator to take evasive action at great risk to himself and the aircraft").

(4) Continually educate the test director on operational suitability terminology, logistics terminology, and methods of data analysis. The test director will need this background for presenting test results and conclusions to HQ AFOTTEC staff.

(5) Maintain contact with the logistics evaluation manager, software evaluation manager, and logistics analysis manager for changes in final report format, content philosophy, and briefing strategies.

(6) Be available for coordinating and briefing the final report at HQ AFOTTEC.

b. Logistics TSG. Logistics TSG personnel should:

(1) Be available to assist the test team in writing the final report.

(2) Obtain test data periodically to use

in preparing the SDD.

(3) Coordinate the SDD with the test team before the team disbands.

8-4. Lessons Learned:

a. Suitability test personnel should not be concerned with a pride of authorship as reports are coordinated through HQ AFOTTEC.

b. Tailor briefings to the intended audience by determining the precise message to be conveyed and stringently controlling the level of detail in the presentation.

c. The test director, DLE, and DSE must be prepared to present briefings on short notice.

d. Host tenant support agreements (AFR 11-4) should specify procedures for obtaining graphics support required in preparation of viewgraphs for briefings.

e. The level of detail of the final report must be consistent with the perspective of the decision maker.

f. Lack of an SDD will preclude reconstruction of test results to support global-analysis studies. Such studies are used to improve test strategies and methodologies.

Part III

KEY OPERATIONAL SUITABILITY EVALUATION AREAS

Chapter 9

AVAILABILITY

9-1. General:

a. A recurrent theme in all guidance documentation concerning operational suitability is the need to evaluate the system's ability to meet operational readiness requirements. System readiness objectives and operational availability goals are established early in each acquisition program and become the basis for evaluating logistics support. Test and evaluation of the system provides data necessary to determine if mature system readiness requirements are achievable. For OT&E purposes, availability is generally considered synonymous with operational readiness (AFR 80-14).

b. System readiness requirements are characterized by a committable condition at a specified time (availability), performance of mission-essential functions without mission aborting failures (reliability), and retaining the system in or restoring it to specified condition (maintainability).

(1) The first readiness objective, ready for commitment, is usually expressed in terms of operational availability (A_0). This chapter discusses the concept of availability and contains definitions of availability, terms used to measure availability, and mathematical expressions of availability. It presents a general approach for evaluating availability which emphasizes the importance of graphically describing a system's status over a time period. This chapter also discusses the need for simulation/modeling and use of simulation models as a primary tool for evaluating a system's long-term availability or readiness characteristics. Attachment 3 presents specific availability applications.

(2) A common expression for the second objective, reliability, is weapon system reliability (WSR). Reliability is discussed in chapter 10.

(3) For the third objective, maintainability, a common expression is mean downtime (MDT). Maintainability is discussed in chapter 11.

c. Availability is the parameter that translates the reliability, maintainability, and logistics supportability characteristics of the system into a measure of interest to the user. It is based on the question "Is the equipment ready in a working condition

when it is needed?" To be realistically evaluated, the evaluator must compare the availability of the system with mission requirements contained in the statement of operational need (ORD) or other requirements documents.

9-2. Availability Requirements:

a. The ORD and the requirements correlation matrix (RCM) specify times (or ranges of times) at which the system may be required to change operating states or conditions. For example, the system illustrated in figure 9-1 is required to halt normal peacetime operations and training, at time t_0 (a random time) and assume a posture of increased readiness prior to commitment at time t_1 . Two operational availability (A_0) measures appropriate to these times might be (1) the number of systems at time t_0 which are capable of assuming an increased readiness posture by time t_1 and (2) the probability that the required number of systems will actually assume an increased readiness posture by time t_1 .

b. The ORD/RCM should also specify the expected/required length of time the system must sustain the increased readiness posture with the required number of committable systems (the time from t_1 to t_2). Thus, another measure of A_0 may be defined as the probability of sustaining in increased readiness posture for a specified time with a specified number of mission-capable systems.

c. The mission length (t_2 to t_3) provides the time base for WSR (i.e., what critical failure-free operating times must be achieved to ensure that the system accomplishes its mission).

d. Many systems will be employed more than once in a wartime scenario (e.g., tactical fighters, bombers, etc.). Therefore, it is important to consider the capability of the system to be regenerated within an acceptable time (t_3 to t_4).

e. The operational availability measures discussed above are also heavily dependent on the maintenance concept, which influences the ability of the system/equipment to be retained in or restored to a specified condition.

f. The main point is there are many A_0

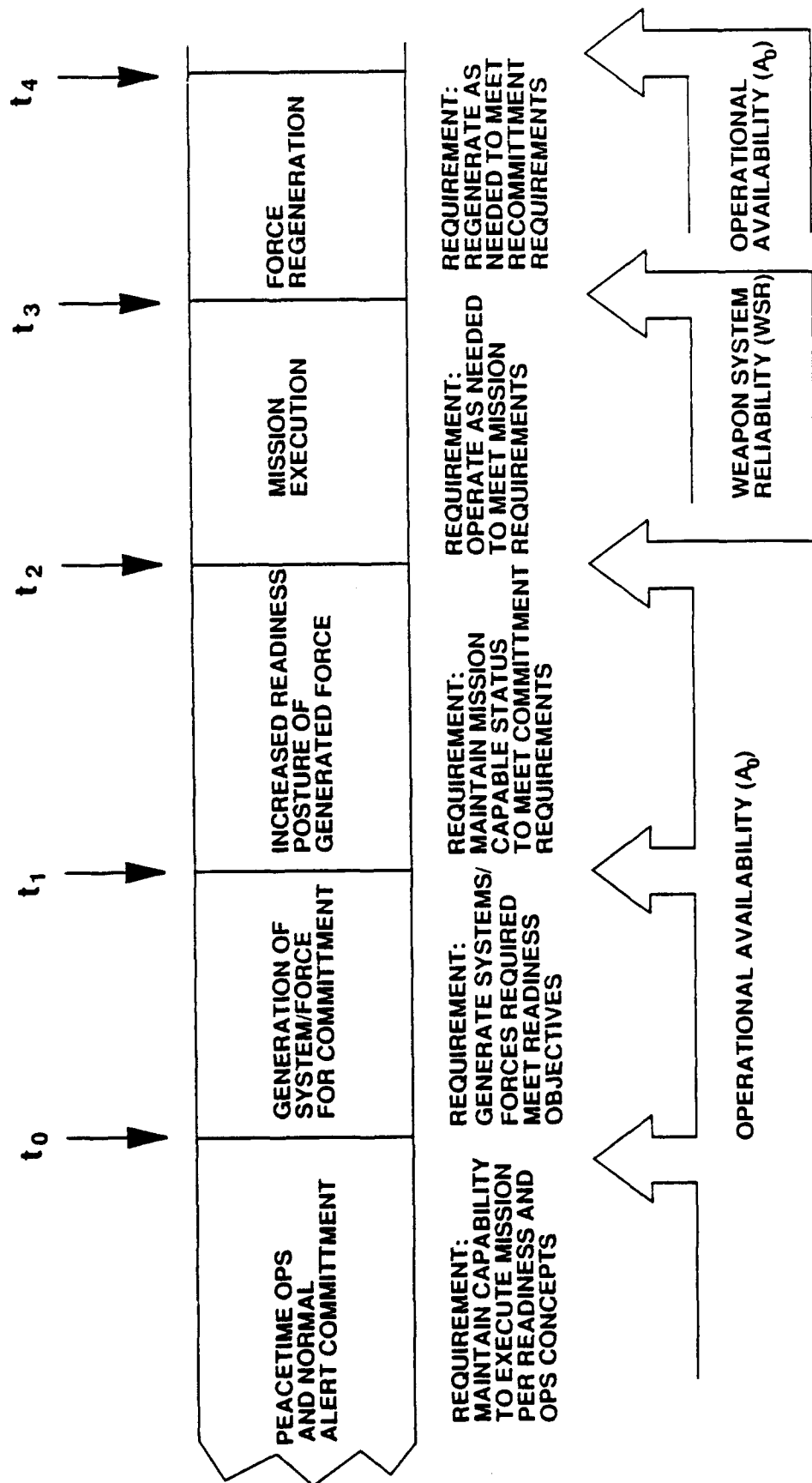

Figure 9-1. System Operational Requirements

definitions which might be used for different systems at different times. There is no cookbook approach which will reflect every system's performance in satisfying its stated readiness objectives.

9-3. "Real" Versus "Apparent" Availability:

a. Traditionally, availability is defined as the ratio of system uptime to total time. This simple definition is appropriate for assessing systems which are used continuously or those which incur relatively short dormancy periods.

b. Recently the Air Force has been developing a number of systems (primarily missiles and munitions) that spend the vast majority of their useful life in storage or in a dormant state. Failures in storage may not be discovered for long periods of time (e.g., missiles may be checked for operability only every few years); for more complex systems, failures may have occurred that are undetectable until a firing event is actually attempted. These situations or state—where an item is failed but undetected (consequently unavailable) for long periods of time—gave rise to the definitional terms of "apparent" and "real" availability.

c. Apparent availability is defined as the percentage of total assets thought to be operable, i.e., perceived as ready for immediate use. Real availability is defined as the percentage of total assets that would actually operate as intended if the user began a mission execution. The words "total assets" are relative to each definition. Limiting the assets to those under test will produce a very narrow (if not useless) view of availability. Limiting the assets to those assigned to a particular squadron, wing, base, etc., can be used to give a focused (mission-scenarios dependent) view of availability. Lastly, considering the entire procurement, phased in over time, will produce a global, force-wide view of availability.

9-4. Definitions:

a. Commonly used availability elements are:

ALDT = Administrative and logistics downtime spent waiting for parts, administrative processing, maintenance personnel, or transportation per specified period.

FMC rate = Full mission-capable rate. The percentage of possessed time a system is

capable of performing all of its assigned peacetime and wartime missions.

MC rate = Mission-capable rate. The percentage of possessed hours a system is operable.

MDT = Mean (maintenance) downtime.

MTBCF = Mean time between critical failures.

MTBF = Mean time between failures.

MTBM = Mean time between maintenance.

MTBUMA = Mean time between unscheduled maintenance actions (unscheduled is generally synonymous with corrective).

MTTR = Mean time to repair (AFP 57-9 defines this as a contractual term).

MTTRS = Mean time to restore system.

MRT = Mean repair time (AFP 57-9 defines this as an operational term).

NMC rate = Not-mission-capable rate. The percentage of possessed hours a system is not capable of performing any of its assigned missions. NMC is generally subdivided by category: NMC for maintenance (NMCM), NMC for supply (NMCS), NMC for both maintenance and supply (NMCB), and further subdivided downtime, by subsystem, or downtime, by subsystem, or other divisions as required.

OT = Operating time (equipment in use).

PMC = Partial mission-capable rate. The percentage of possessed time a system is

capable of performing at least one, but not all, of its assigned wartime missions.

- ST = Standby time (not operating but assumed operable) in a specified period.
- TCM = Total active corrective (unscheduled) maintenance time per specified period.
- TDT = Total downtime per specified period = TMT + ALDT.
- TMT = Total active maintenance time per specified period = TCM + TPM.
- TPM = Total active preventive maintenance time per specified period (scheduled is generally synonymous with preventive).
- TT = Total intended utilization period or total time. [Possessed time in AFR 65-110, Aerospace Vehicle and Equipment Inventory, Status and Utilization Reporting System (AVISURS).]
- UR = Uptime ratio. Communications, electronics, and meteorological systems as the percentage of possessed time they are "operational."

b. Terms used in the availability evaluation must be clearly defined. For example, assessing the availability of operational aircraft generally assumes a 7-day-per-week total time (TT) period. If the aircraft are not normally flown or maintained on weekends and are left in an "up" status Friday night, using a 5-day-per-week TT will generate lower availability results.

c. Other definitions associated with availability may also significantly affect the results. For example, are "before and after" operation checks conducted in conjunction with preventive maintenance excluded from downtime because the equipment is assumed operable? How is administrative and logistics downtime determined; is it assumed, calculated, or observed? What is the opera-

tional status of a system during the warm standby period? For repeatability and comparability of the results, all terms and procedures to be used in the availability evaluation must be defined in the test plan.

9-5. **Mathematical Expressions of Availability.** The following expressions are those of the classical theoretical approach. HQ AFOTTEC and test teams presently use some of these. The basic mathematical definition of availability is:

$$\text{Availability} = A = \frac{\text{uptime}}{\text{total time}} = \frac{\text{uptime}}{\text{uptime} + \text{downtime}}$$

Availability is assessed by substituting the time-based elements defined previously into various forms of the basic equation. Different combinations of elements combine to formulate different definitions of availability. The definitions of what is included in uptime and what is included in downtime depend on mission requirements contained in the mission-essential subsystem list and the MNS/ORD and the critical issues developed from them as defined in the test plan.

a. **Operational Availability (A_o):**

(1) Operational availability covers all segments of time during which the equipment is intended to be operational. Uptime includes operating time plus nonoperating (standby) time (when the equipment is assumed to be operable). Downtime includes preventive and corrective maintenance and associated administrative and logistics delay time.

$$A_o = UR = \frac{OT + ST}{OT + ST + TPM + TCM + ALDT}$$

This relationship provides a realistic measure of equipment availability when the equipment is functioning in its operational environment.

(2) One significant problem associated with determining A_o is it becomes costly and time-consuming to define and measure the various parameters. For example, the procedures of AFR 65-110 for aircraft availability measurement (FMC and PMC) require substantial time and a large number of test assets in an operational environment to produce valid results. Defining administrative and logistics downtime (ALDT) and total active preventive maintenance time (TPM) under combat conditions is not feasible in most instances. Nevertheless, the operational availability expression does provide an accepted technique of relating standard reliability and maintainability elements into a mission-oriented parameter.

(3) One important aspect to note is the

utilization rate affect A_o . The less a system is operated in a given period, the higher A_o will be. It is important, therefore, when defining the total time period to exclude lengthy periods during which little or no system usage is anticipated, such as depot maintenance and nonoperating storage time. Care should also be taken not to inadvertently exclude periods of time which are a part of the operational environment, e.g., an aircraft sitting in an FMC status over a weekend.

(4) Another frequently encountered expression for A_o is:

$$A_o = \frac{MTBM}{MTBM + MDT}$$

While logistics-oriented, this form of A_o retains consideration of the same basic elements. The MTBM and MDT intervals may include corrective and preventive maintenance and administrative and logistics downtime. This form of the A_o relationship would generally prove more useful in support of early parameter definition and sensitivity analysis.

(5) A closely related expression for A_o is:

$$A_o = \frac{MTBM}{MTBM + MTTRS + MLDT + MDT_{other}}$$

MTBM can include inherent failures, induced failures, no-defect maintenance actions, and preventive maintenance or any combination of these.

MTTRS includes preparation time, malfunction verification time, fault isolation deflection time, repair time (replacing, repairing, or adjusting), malfunction final test time, and system final test time if applicable.

MLDT is the average delay time considering maintenance actions which require parts and those which do not. It can include base level and depot supply systems.

The basic expression of MLDT is:

$$MLDT = (A) (MSRT)$$

Where:

A = Percentage of corrective maintenance actions requiring parts.

MSRT = Mean supply response time or the weighted average of

response times from base stocks and from the depot system.

MSRT can be calculated by the following equation:

$$MSRT = (C) (D) (E) + [1-(D)(C)] (F)$$

Where:

C = Percentage of parts-required maintenance actions that are supported by parts carried (allowed) in base stocks.

D = Percentage of allowed parts requirements normally satisfied from base stocks.

E = Time required to obtain a part from base stocks.

F = Mean requisition response time (MRRT).

MDT_{other} is the mean delay time for other reasons such as waiting for maintenance personnel or transportation. It does not include supply delay time. Although several miscellaneous downtimes can be incorporated in this segment of supportability, such potential downtime should not be considered minor or insignificant. One or more deficiencies in this area can severely limit supportability and hence A_o .

(6) The last expression for A_o to be presented is based on FMC, MC, and/or PMC. FMC, MC, and PMC are measures of A_o .

b. Achieved Availability (A_a):

(1) The definition of achieved availability is mathematically expressed as:

$$A_a = \frac{OT}{OT + TCM + TPM}$$

(2) A_a is frequently used during development testing and initial production testing when the system is not operating in its intended support environment. Excluded are operator before-and-after maintenance checks and standby, supply, and administrative waiting periods. A_a is much more a hardware-oriented measure than is operational availability, which considers operating environment factors. It is, however, dependent on the preventive maintenance policy, which may be greatly influenced by non-hardware considerations.

c. Inherent Availability (A_1):

(1) Under certain conditions, the logistics evaluator may find it necessary to define system availability with respect only to operating time and corrective maintenance. Availability defined in this manner is called inherent availability (A_1):

$$A_1 = \frac{MTBF}{MTBF + MTTR}$$

(2) Under these ideal conditions, the evaluation may ignore standby and delay times associated with scheduled or preventive maintenance, as well as administrative and logistics downtime, no defect maintenance, and maintenance due to induced failures.

(3) Inherent availability is useful in determining basic system operational characteristics under ideal conditions. Inherent availability can also describe combined reliability and maintainability characteristics or define one in terms of the other during early conceptual phases of a program when, generally, these terms cannot be defined individually. Since this definition of availability is easily measured, it is frequently used as a contract-specified requirement.

9-6. A General Approach for Evaluating Availability. The following paragraphs present a general approach for evaluating system availability. It is important to note for such an analysis to be meaningful to an equipment user or developer, it must reflect the peculiarities of the system being considered. The general procedures are:

a. The operational and maintenance concepts associated with system use must be defined in detail using terminology compatible with the users.

b. Using the definitions from paragraph 9-4, construct a time line availability model which reflects the mission-availability parameters. Figure 9-2 displays elements of availability frequently included in a quantitative assessment of availability. The up or down status of a specific system during preventive maintenance must be closely examined. Generally, a portion of the preventive maintenance period may be considered as uptime. Cold standby time must also be examined closely before determining system up or down status during this period. The time line availability model may also be constructed using other commonly used reliability and maintainability parameters. Figure 9-3 illustrates another approach to an availability time line model.

c. With the aid of the time line model, determine which time elements represent

"uptime" and "downtime." Do not be misled by the apparent simplicity of this task. For example, the maintenance concept may be defined so that the equipment must be maintained in a committable state during the performance of preventive maintenance.

d. Determine quantitative values for the individual time elements of the time line models. Coordinate these values with the user, developer, and contractor.

e. Compute and track availability using the definitions of availability appropriate for the current stage of system development.

f. Continue to check availability model status and update the model as required. Give special attention to updating the model as the operational, maintenance, and logistics support concepts mature.

9-7. Recovery Time Considerations in System Availability:

a. Normally, availability measures imply every hour has equal value from the standpoint of operations and the performance of maintenance and logistics activities. Additionally, the operational concept requires the system to function for selected periods. The remaining time is traditionally referred to as "off-time," during which no activity is conducted.

b. An alternative to the "off-time" or "cold standby" concepts is the use of the term "recovery time" (RT) as depicted in figure 9-4.

c. RT represents an interval of time during which the system may be up or down. RT does not appear in the availability calculation, which is based only on the TT period. Take special note of the fact total active corrective maintenance time (TCM--maintenance required to keep the system in a mission ready or available status) is found in both TT and RT. Corrective maintenance performed during the RT period generally addresses hardware malfunctions which do not result in a non-mission-ready status.

d. The principal advantage of using the "recovery time" analysis is it can provide a more meaningful availability assessment for systems whose periods of required availability are predictable and whose preventive maintenance constitutes a significant but delayable portion of the maintenance burden.

9-8. Availability for Multimission Systems. For many modern weapon systems, availability is not simply an up or down condition. Systems such as aircraft have multimission/mode capabilities and thus require detailed techniques to characterize the associated availability states. The defini-

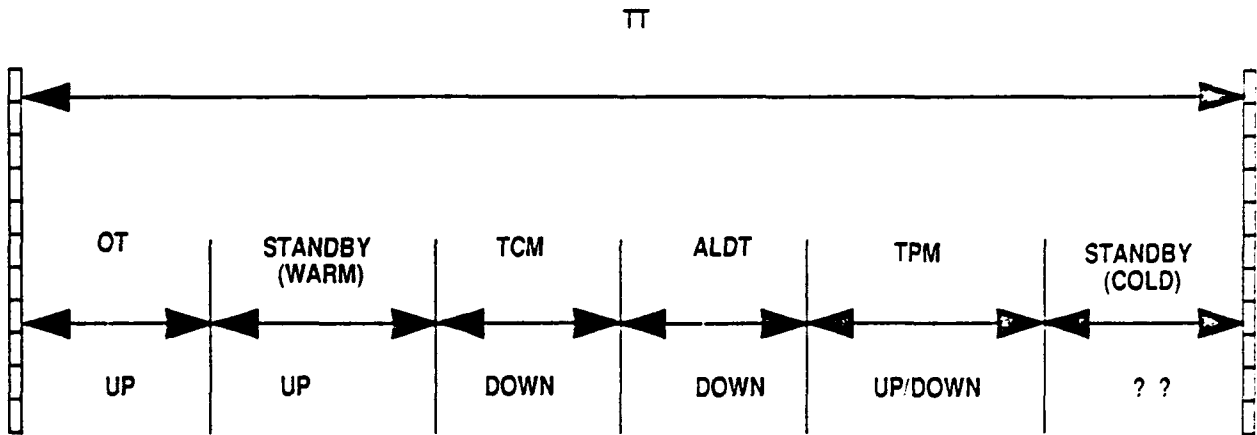

Figure 9-2. Mission Availability Time Line Model (General Format)

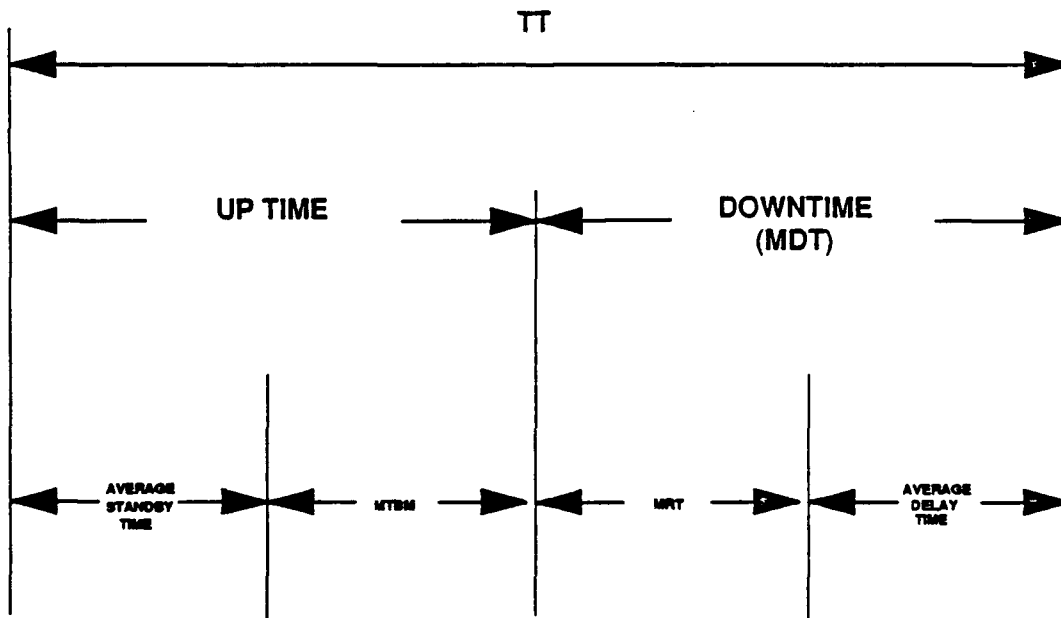

Figure 9-3. Operational Availability Time Line Model

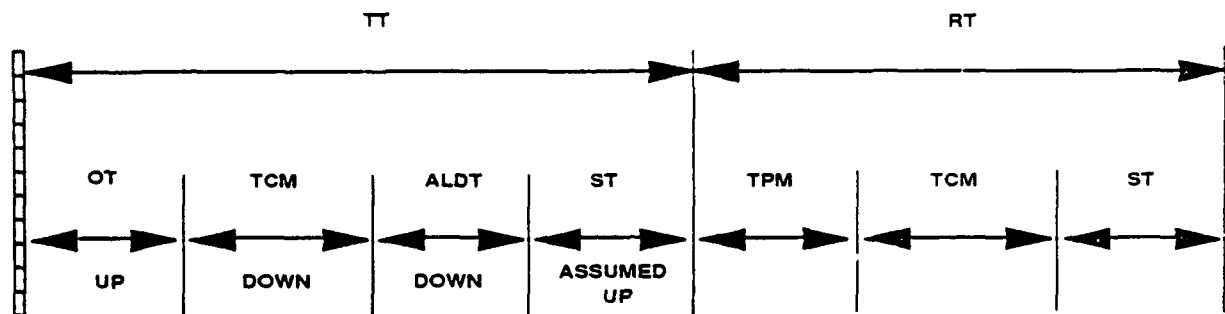

Figure 9-4. Mission Availability Time Line Model (Recovery Time Format)

tion of terms, modes, and states is especially important in the analysis of these complex systems. Generally, each mission/mode will require a separate time line model.

9-9. Data Analysis. Much of the data required to evaluate availability comes from the results of the reliability, maintainability, and logistics supportability evaluations. Initial estimates of availability are usually established from contractor predictions and updated by the test team during test execution. Sensitivity of availability to changes in reliability, maintainability, and logistics supportability parameters at the subsystem level is analyzed by incrementally changing MTBMs, MDTs, MTBCFs, delay times, etc., to identify constraints and to determine if one or some combination of the parameters significantly changes the availability.

9-10. Availability Simulation/Modeling. Paragraph 9-6 discussed a general approach for evaluating system availability using time lines and direct calculation of operational, achieved, and inherent availability. Another approach is to construct and run a simulation model of the system and its support structure. This model is based on the user's operations and maintenance concepts, user definitions of availability and the time line analysis presented in paragraph 9-6. By emulating the operational employment of the system, a simulation model gives the analyst a powerful tool to evaluate a system's readiness and the factors that influence it.

a. Justification for Simulation:

(1) Availability is a measure of the degree to which an item is in the operable and committable state at the start of the mission when the mission is called for at a random point in time. For a given utilization rate, availability depends on the reliability and maintainability characteristics of the

system and the support posture of the logistics supportability factor involved.

(2) Availability is not a direct characteristic of the system but rather is a result of system characteristics such as those mentioned above. Point estimates of availability, calculated from current and past observations, can provide an overall measure of past performance and can be used as a management indicator. However, even during OT&E of weapon systems in the final stages of the acquisition process, availability data generally cannot be used alone to provide reasonable projections of expected future system availability.

(3) Early in the acquisition phase, before the production decision, systems under test do not reside in an operationally representative environment. Additionally, the support system (manpower, test equipment, technical manuals, etc.) is not representative of the one the Air Force will use when the weapon system is fielded. In short, predictions of expected future availability must be made in the context of expected future system characteristics and scenarios. The predictions are continuously refined as the system matures and early test data are replaced by findings in more operationally representative environments.

(4) The AFOTTEC Logistics Studies and Analysis Division (LG4) uses computer simulation models to estimate future availability of weapon systems when maintained and operated in accordance with the using command's maintenance and operational concepts in peace and war. Models allow for extensive "what if" questions and help quantify impacts of proposed changes to the system. With proper information regarding expected system availability, decision makers can call for changes in the operational and maintenance concepts, manpower levels, spare part policy, etc., to accommodate the unique

requirements of the system.

(5) AFOTTEC uses several computer languages to develop simulation models. The major languages are the simulation language for alternative modeling (SLAM) and logistics composite model (LCOM). SLAM is a high-level simulation language and is used extensively by HQ AFOTTEC/LG4. The LCOM simulation package is a standard Air Force data system and is used extensively by the manpower community.

b. Modeling Methods and Tools. If the decision has been made to use simulation modeling for analysis of system availability, it is generally more cost- and time-effective to use existing models such as LCOM and dedicated modeling languages like SLAM rather than to develop a model code from scratch. The analyst will be concerned with simulating system failure and repair characteristics as well as activity flow and day-to-day operations in a clearly defined scenario or operational situation. Selection of simulation tools is dependent on the system under evaluation, the computer system to be used, and the time and resource available for model development and analysis. Each of the tools offers particular advantages for particular applications.

(1) SLAM combines process-oriented capabilities with continuous simulation and event scanning capabilities. SLAM is FORTRAN-based and allows the modeler to use FORTRAN subroutines to enhance SLAM capabilities. SLAM provides a set of standard subprograms that the modeler can use to schedule events, manipulate files, collect statistics, and generate random samples.

(2) The LCOM was designed to model aircraft operations and support functions at base- or wing-level. LCOM may be used to model a system other than aircraft operation and support, but the system must be analogous to an air base operation. Since the logic used to describe aircraft maintenance is similar to many other process-oriented operations, LCOM can be applied to a fairly large number of systems, e.g., the Space Transportation System. Analysts competent in the use of LCOM can modify and apply it to any situation or environment that can be represented as a network using tasks which require time and/or resources for accomplishment.

c. Model Level of Detail Requirements:

(1) The level of detail a simulation model requires depends on the system under test and the time and resources available for model development. Generally, items in the early phases of acquisition cannot and should

not be modeled to a great level of detail, since maintenance processes and policies have not been fully established. For more complex and sophisticated items, modeling of subcomponents may need to be accomplished at the major component level because of lack of data and maintenance concepts. For more mature systems, the modeler may have a wealth of information on existing piece parts and maintenance processes. In this case, a more detailed model may be desired.

(2) As a minimum, the model should consider the factors shown in figure 9-5. Each of the factors or parameters may be specified in the model at various levels of detail, and it is incumbent on the model developer to correctly specify the level of detail IAW the test requirements and the time and resources available.

d. Availability Measures of Effectiveness (MOE) in Modeling. Simulation models can calculate availability measures in many ways. A great deal of care is needed to ensure the model output is what is required or desired. It is somewhat difficult to obtain "nonstandard" outputs from LCOM. However, SLAM allows the analyst to carefully define the desired measures and to ensure the model is correctly accounting for these measures during model execution.

e. Obtaining Model Input Data:

(1) The amount of input data required for the execution of the model can be significant, depending on the level of model detail. It cannot be emphasized enough that the quality of the input data is directly related to the amount of confidence one can place on the resulting availability estimates.

(2) In most system evaluations, reliability characteristics will be the most important factor influencing availability. Early in the procurement and testing process, the analyst may have to rely on the development contractor for reliability estimates of the system components. However, the analyst may obtain independent estimates of reliability parameters from comparability analysis and/or independent research and judgment. After deployment of the system, the analyst may use actual failure history data and test results.

(3) Similarly, maintainability data may initially be obtained from the contractor. In addition, the analyst must work with experienced maintenance personnel or personnel familiar with similar systems to further estimate maintenance times and to determine maintenance processes (i.e., networks). As testing proceeds, actual measured data may be used to update preliminary data values.

(4) The system operational and main-

- o Reliability parameters
 - Mean time between downing events (or MTBM) for components and/or system (including dormant reliability if applicable)
 - Operating time characteristics in various states
- o Maintainability parameters
 - Setup/fault isolation/remove/repair/checkout times for components
 - BIT/FIT effectiveness parameters
- o Logistics supportability parameters
 - Support equipment requirements
 - Facility requirements
 - Repair part stockage policies (onhand inventories, WRSK, POS, and cannibalization policy)
 - Supply characteristics, including transportation delays between field and depot
- o Maintenance policy parameters.
 - Scheduled maintenance periods
 - Level of repair considerations
- o Scenario and conditions
 - Peacetime conditions
 - Wartime mission definition

Figure 9-5. Factors to Include in Availability Modeling

tenance concepts can be used for setting maintenance policies, defining mission scenarios, and determining manpower, facilities, and support equipment characteristics. Coordination meetings should be held with the appropriate using command personnel to keep abreast with current concepts.

f. Example: F-15E Availability Model. The F-15E availability model is an analysis tool used in the operational suitability evaluation of the F-15E during combined developmental test and evaluation and operational test and evaluation (DT&E/OT&E) and the dedicated operational test and evaluation (OT&E) phases. The model is used to evaluate the availability, mission reliability, and maintainability of a mature F-15E squadron during various scenarios. Availability is measured by mission capable (MC) rate and

sortie generation rate (SGR). Mission reliability is measured by break rate (BR). Maintainability is measured by fix rate (FR), mean repair time (MRT), and manpower spaces per aircraft (SPA). Figure 9-6 depicts the F-15E model flow.

(1) The model was built to describe the major aspects of the HQ TAC operational environment. Similar flying schedules, sortie length, maintenance priorities, maintenance concepts, resource allocation per Air Force specialty code (AFSC), resource usage per AFSC, and scheduled and unscheduled maintenance per four-digit work unit code (WUC) are included. Mean times between maintenance (MTBM) and maintenance task times for subsystems are inputs to the model. Unknowns in the model, such as what time items fail, are calculated in the model using

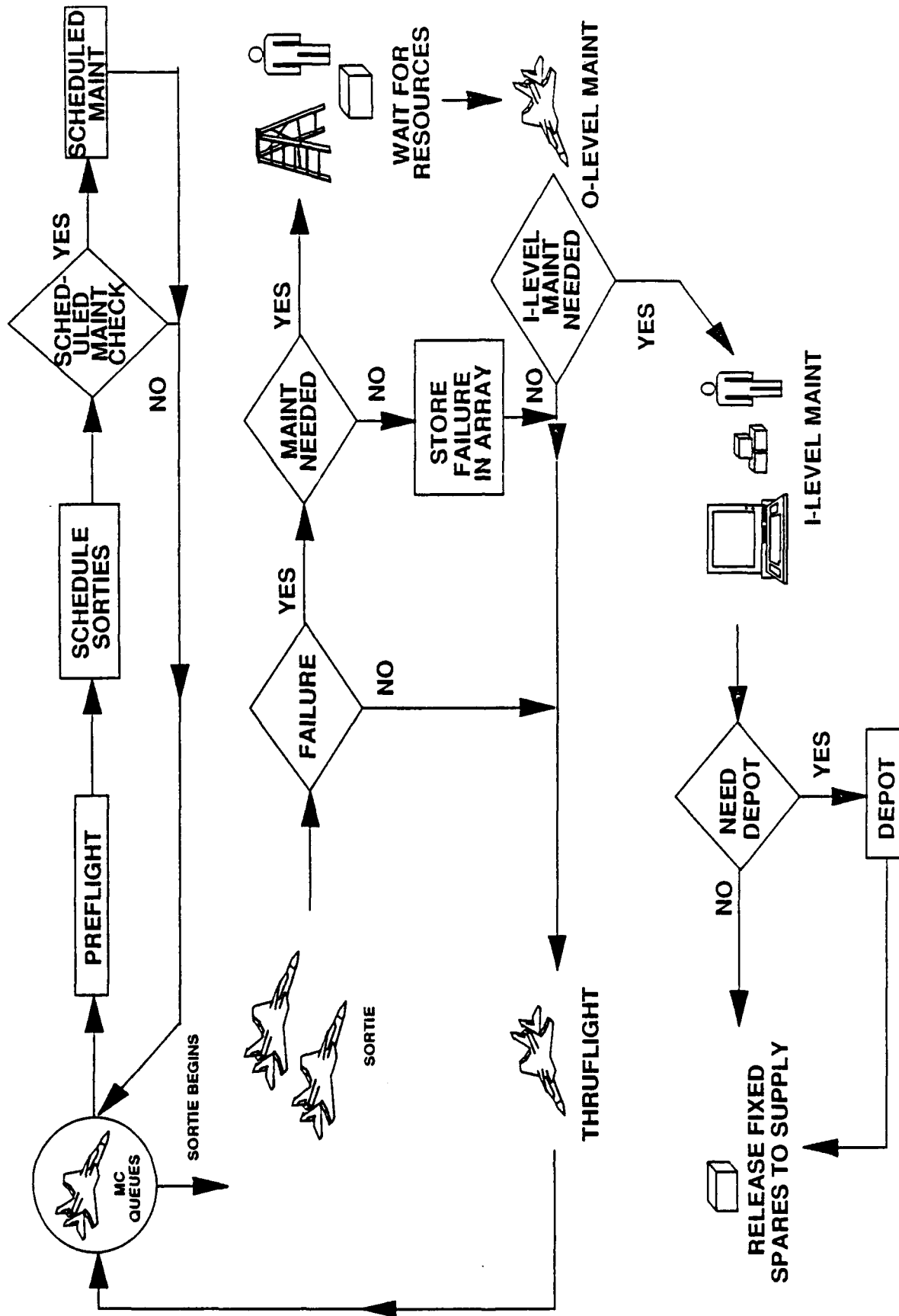

Figure 9-6. F-15E SLAM Flow

MTBM data and probabilities.

(2) Manpower resources are specified by AFSC and in some cases by skill level. The F-15E manpower allocations and usage follow the intended maintenance concept (rivet workforce). Quantities of maintenance personnel of a certain AFSC can be decreased or increased to determine the effect on F-15E availability. Many other items, such as support equipment availability, spares levels, MTBM, and task times, may be varied to answer "what if" questions and perform sensitivity analyses.

(3) The model operates by beginning the simulation at time = 0, and permitting scheduled events such as scheduled maintenance and flying sorties to occur. After each sortie, the failure clocks for each WUC are checked to see if a failure occurred on that sortie. If a failure did occur, the necessary organizational-level maintenance and thru-flight maintenance are performed and the aircraft is ready to fly again. Shop maintenance is also begun on removed LRUs, if needed. The simulation continues until the end of the simulation time is reached. The model actually "simulates" what occurs at a TAC flying squadron.

(4) A random number generator is used to obtain random samples from a specific statistical distribution: triangular, normal, exponential, or lognormal. For each simulation of a scenario, at least five different random number seeds are used for the random number generator. The five simulation results are averaged to obtain the "final" results.

9-11. Lessons Learned:

a. Studies of major weapon systems during test and evaluation have proven to be extremely labor intensive, requiring interaction among the model builder and the system developers, users, testers, and supporters. To provide timely, useful analyses in a compressed acquisition/test environment, HQ AFOTTEC/LG4 initiated model committees to support model development and studies. To better implement the intent of Director, Operational Test and Evaluation (DOT&E) policy, HQ AFOTTEC/LG4 directed a committee approach to modeling/simulation (M/S) application, development, and documentation. An M/S committee, composed of the LG4 M/S technical advisor, the primary analyst of the system, and additional analysts, will be formed for each M/S effort designated by LG4. Primary objectives of each M/S committee are to provide a forum for review and for guiding steps taken during the M/S development effort to establish M/S credibil-

ity, to provide a forum for exchanging M/S ideas and techniques between analysts, to ensure a verified and validated M/S product, and to recommend M/S documentation for release to outside agencies. In addition, the committee review structure is intended to maintain independence between M/S development and its use to support OT&E.

b. Timely collection of data for subsystem availability evaluation must be addressed during advance planning. The analyst must determine data requirements and assess the best method of acquiring the data. If the test will be run at a contractor facility with the contractor performing the maintenance, specific preparation is vital. The contractor should be required to collect, document, and provide all data necessary to perform a complete system analysis.

c. The maturity of the system will influence the emphasis given to an availability evaluation. An example of the changing emphasis is the F-16 development. During IOT&E with prototype aircraft, availability was not assessed, but specific hardware reliability and maintainability deficiencies were reported for correction. During OT&E, using full-scale development aircraft, availability was determined using definitions and procedures contained in the test plan. Finally, during multinational OT&E (MOT&E), AFR 65-110 procedures were applied to the fleet of operational aircraft to measure FMC, PMC, and other availability rates.

d. The test environment can have a major effect on the evaluation of system availability. During IOT&E, and particularly during combined DT&E/IOT&E, contractor maintenance may be oriented toward completing specific test events rather than maintaining systems in a mission-capable status. In addition, the system may be down for extended periods while undergoing development modifications. It is important, therefore, to reach a common agreement with all test participants as to what time base will be used in the availability computations. Lengthy periods during which little or no system usage occurs should be critically examined for applicability to the system's availability calculations.

9-12. Key References for Availability:

a. AFR 65-110, Aerospace Vehicle and Equipment Inventory, Status, and Utilization Reporting System (AVISURS).

b. AFP 57-9, Defining Logistics Requirements in Statement of Operational Need.

c. DOD 3235.1-H, Test and Evaluation of System Reliability, Availability, and Maintainability--A Primer.

d. MIL-STD 721. Definitions of Effectiveness Terms for Reliability, Maintainability, Human Factors, and Safety.

e. HQ AFOTTEC/LG4 Guidelines for Modeling and Simulation (M/S) Application, Development, and Documentation.

Chapter 10

RELIABILITY

10-1. General:

a. Reliability is a key factor which influences a system's effectiveness, logistics support requirements, and life cycle cost. Together, the reliability and maintainability characteristics of a system help determine the system's operational readiness.

b. Reliability quantitatively describes the degree to which a system is likely to be failure-free during a given period of operation understated conditions. The ability to express reliability numerically is important because it enables personnel involved in the acquisition process to concretely identify the user's needs, contractual specifications, test guidelines, and performance assessment. When evaluating reliability, OT&E must not only address the system in terms of its ability to complete the mission but also in terms of the effect on the logistics system.

c. This chapter presents background material on reliability, current Air Force and DOD policy regarding reliability, and an approach for evaluating reliability during T&E.

10-2. Reliability Requirements. AFP 57-9, Defining Logistics Requirements in Statements of Operational Need, divides reliability terms into two categories, operational and contractual.

a. **Operational.** With the implementing and supporting commands' assistance, the using command develops reliability requirements based on mission needs which are expressed in operational terms. AFP 57-9 includes a list of acceptable operational reliability terms and their definitions to be used in statements of operational need, maintenance concepts, program management directives, and program management plans. These terms describe the required reliability performance of the total system and its supporting elements when operating in its planned environment. During acquisition, they are used to plan and manage the reliability program and to evaluate reliability performance. Operational reliability requirements also provide the basis for conducting OT&E, and the program decision authorities use these to evaluate achievement of thresholds and mature reliability performance. Therefore, it is imperative that OT&E test plans reflect the operational requirements and terminology expressed in the operational and support planning documents.

b. Contractual:

(1) The implementing command develops contractual reliability and maintainability terms (generally limited to events which are subject to control by the contractor) from the operational terms and incorporates them into contracts. The prediction and measurement of contractual terms do not always provide values that can be directly compared to operational terms. Therefore, the implementing command must clearly identify each contractual term to prevent any confusion with similar operational terms and must establish an audit trail to relate these terms.

(2) Each weapon system and equipment acquisition authorized by a specific program management directive (PMD) is required to have a reliability and maintainability management plan (RMMP). The RMMP will be updated annually or as significant program changes occur. It is a description of the reliability and maintainability (R&M) program for achieving the user's R&M requirements and thresholds. The plan provides parameter translation methodologies used to translate the operational R&M requirements into measurable, enforceable contractual requirements (including test terms).

10-3. Definitions and Concepts. Standard terminology is vital to good communications between all participants involved in a system's acquisition. Lack of standard terminology has traditionally caused many problems. The primary objective of standard terminology is to have the users, developers, testers, and supporters all use a common baseline or assessment of reliability performance. Reliability terms are defined in MIL-STD 722, the Multiservice Memorandum of Agreement (MOA) for OT&E, and other sources (see attachment 5). Important reliability concepts are clarified below:

a. Reliability:

(1) Reliability is defined as the probability an item can perform its intended function over a specified interval under stated conditions. Reliability is also defined as the duration or probability of failure-free performance under stated conditions.

(2) If a system is capable of performing multiple missions or if it can perform one or more of its missions while operating in a degraded condition, the concept of a unique mission reliability becomes difficult to define. In such cases, it is preferable to use a relia-

bility measure that is not based solely on the length of a specified time interval but rather on the definition of a specific mission profile or set of profiles.

(3) The meaning of the terms "stated conditions" and "specified interval" are important to the understanding of reliability. The term "stated conditions" refers to the complete definition of the scenario in which the system will operate, be maintained, and be supported. For aircraft, operating conditions may include park, taxi, takeoff, climb, cruise, air-refuel, air combat, and other related activities. For strategic missiles, the conditions would include the alert posture. Whatever the system, the stated conditions should reflect operational use. The term "specified interval" refers to the length of the mission described in a mission profile. This interval may include multiple factors. For example, for a fighter aircraft, an air-to-air combat engagement profile will define an interval containing X hours of radar on time, Y rounds fired, and Z hours flown. The specified interval is a segment of the mission profile which requires certain activity to take place using equipment to accomplish that activity.

b. Reliability Incident Classification:

(1) **System Failures.** System failures are hardware malfunctions or software errors. They may or may not affect the mission's essential functions, and they may or may not require spares for correction.

(2) **Mission Failures.** Mission failures are the loss of any of the mission's essential functions. System hardware failures, software errors, operator errors, and errors in technical orders that cause such a loss are included in this category.

(3) **Inherent Failure.** The item can no longer meet the minimum specified performance because of failure resulting from internal design and manufacturing characteristics.

(4) **Induced Failure.** The item can no longer meet the minimum specified performance because of some induced condition and not because of its own internal failure pattern.

(5) **No-Defect Maintenance Action.** Maintenance resources were expended because of policy, modification, location, or cannibalization, and no defect was identified at the time of maintenance.

(6) **System/Mission Failures Requiring Spares.** Failures of system/mission essential equipment that require spares for correction.

(7) **Unscheduled Spares Demand.** All unscheduled spares demands require a response from the supply system, so they form the basis for evaluating supply-related reliability.

bility.

c. Chargeable/Nonchargeable Failures.

(1) Contract requirements are often established for the subset of mission failures and/or system failures for which the contractor can be held accountable. Normally excluded from contractual chargeability are such failure categories as operator or maintenance errors, item abuse, secondary failures caused by another primary failure, and failures for which a "fix" has been identified but not incorporated in the test article that failed.

(2) In operation, all failures (in fact, all unscheduled maintenance actions) are relevant regardless of contractual chargeability and should be included in operational evaluations. One exception is failures caused by test-unique hardware, software, procedures, etc., are generally nonrelevant (i.e., nonchargeable) to the contractual (DT&E) and operational (OT&E) evaluations.

d. Mean Time Between Failure (MTBF).

MTBF is a contractual term defined as the total functioning life of a population of an item during a specific measurement interval divided by the total number of failures within the population during the interval. MTBF can be interpreted as the expected length of time a system will be operational between failures. The definition is true for time, cycles, flying hours, or other measure-of-life units. These various measure-of-life units permit the MTBF term to be tailored to the reliability requirements of a specific system. When MTBF is specified as a constant, it is based on the assumption the underlying failure distribution is exponential. Under this assumption, the probability a system will operate without failure for time t (i.e., its reliability) is $R(t) = e^{-t/MTBF}$.

e. Failure Rate. The number of failures of an item per measure-of-life unit (e.g., cycles, time, miles, or events as applicable). The failure rate is the reciprocal of the MTBF.

f. Hardware Failures Versus Software Failures (Errors):

(1) When a system that incorporates hardware and software is undergoing OT&E, there will be failures because of hardware components and/or computer programs (software). Software failures have the same net effect on system performance as hardware failures; therefore, a need exists to determine the "reliability" of the software and its impact on system availability.

(2) Some basic definitions in this discussion are:

(a) **Failure.** The inability of a system

or system component to perform a required function within specified limits. A software failure may be produced when a software fault is encountered.

(b) **Software Fault.** A manifestation of an error in software which, when encountered, may cause a software failure.

(c) **Software Error.** A human action which results in software containing a fault. Examples include omission or misinterpretation of user requirements, incorrect translation or omission of a specification requirement, etc. (IEEE STD 729-1983).

(3) A basic difference between hardware and software is that hardware fails periodically over time, software does not. Hardware failures which have been repaired can recur, and a failure rate can be established for the particular item. In contrast, software does not degrade. A perfect computer program would not deteriorate and would remain failure free throughout its useful life. Software faults which cause system failures were built into the program but not previously detected. However, once a particular software fault has been discovered and corrected, it will not occur again. This is not to say the software is reliable. As a result of the correction process, additional software errors may be introduced into the system (a concept referred to as "imperfect debugging").

(4) Current test and evaluation methodologies assume all software faults will be fixed by system maturity. System reliability is therefore projected solely on the basis of hardware failures. An erroneous picture of system reliability can thus be presented to the user and senior decision makers. Reliability assessments and projections directly feed into equations of operational availability. An erroneous reliability will yield an erroneous availability.

(5) Software reliability is the probability that software will not cause the failure of a system for a specified time under specified conditions. The probability is a function of the inputs to and use of the system rather than a function of the existence of faults in the software. The inputs to the system determine whether existing faults, if any, are encountered.

(6) HQ AFOTTEC has developed a method to determine the effects of software on system reliability. Software maturity data gathered during developmental and operational testing are used as input to the software failure rate model. The effects from software enhancements developed during block release cycles and fault introduction through error correction are added to give a comprehensive yet practical measure of software reliability.

An estimate of the total number of faults in a software system is determined from the failure rate, and a software mean time between critical failure (MTBCF) is defined.

(7) Even though there is a basic difference between hardware and software failure, the net effect on system performance is essentially the same. A method for assessing and predicting the software's effects on system reliability will provide decision makers with a better understanding of the operational suitability of weapon systems entering the inventory. A true system reliability picture at system maturity can be given by providing an expected number of critical software failures as well as a mean time between each critical system failure caused by software. Thus, the evaluator must consider the effects of software failures in the final assessment of a system/equipment's reliability and the impact on effectiveness and availability. (For a further discussion of AFOTTEC's approach to the evaluation of software, see chapter 12, Software Evaluation, of this pamphlet and AFOTTECP 800-2, Software Operational Test and Evaluation Guidelines.)

10-4. R&M Policy Guidance. AFOTTEC responsibilities (AFR 800-18):

a. Assign an R&M OPR at AFOTTEC headquarters. (That OPR is the Logistics Studies and Analysis Division (HQ AFOTTEC/LG4).)

b. Develop reliability test objectives, methodology, data requirements, evaluation criteria, and analytical techniques to include in AFOTTEC OT&E test plans. Approve these same elements in Air Force-directed, MAJCOM-conducted OT&E test plans.

c. Review program documentation (such as operational and support concept documents, decision coordinating papers, and program management directives (PMD)) for the adequacy of reliability parameters for measurement and evaluation during OT&E. Provide inputs into program documentation for assessment of these reliability parameters during OT&E.

d. Develop methods, policy, and procedures for evaluating R&M during OT&E and provide guidance to other OT&E agencies.

e. Plan, conduct, monitor, and report the results of logistics assessments performed during OT&E of systems and equipment. This assessment includes reliability and maintainability evaluations of PMD thresholds and the use of reliability data in evaluating logistics supportability.

f. Identify the estimated OT&E data requirements to the implementing command

in time to allow for adequate funding. Provide OT&E data requirements to the implementing command to include in contracts.

g. Help the implementing command, AFLC, and HQ USAF develop and implement data systems for verification of reliability performance during DT&E, assessment during OT&E, and measurement of product performance throughout the system's life cycle.

h. Provide ATC with OT&E philosophy, policy, and experience to develop and improve reliability engineering education and training programs and courses. Conduct reliability training courses or seminars, as required.

10-5. System Reliability Design Objectives. There are two very different system reliability design objectives. One is to enhance system effectiveness; the other is to minimize the burden of owning and operating the system. The first objective is addressed by means of mission reliability, the second by means of logistics-related reliability. Measures of mission reliability address only those incidents that affect mission accomplishment. Measures of logistics-related reliability address all incidents that require a response from the logistics system.

a. **Mission Reliability.** The probability a system will give a specified performance for the duration of a mission when used in the manner and for the purpose intended, given the system is functioning properly at the start of the mission. The following terms relate to mission reliability:

(1) **Aircraft Abort Rates.** Often used to assess aircraft mission reliability and include before flight abort (BFA) rate, in-flight abort (IFA) rate, and total abort rate. The BFA rate is the percentage of attempted sorties that fail to become airborne because of failures discovered by the aircrew before takeoff. The IFA rate is the percentage of sorties which become airborne that subsequently fail to complete the defined mission because of a failure discovered during flight. The total abort rate is the sum of BFA and IFA rates.

(2) **Captive-Carry Reliability (CCR).** The probability a missile or munition will remain failure free while loaded and carried on the host aircraft.

(3) **Dormant Reliability (DR).** The probability an item will remain failure free for a specified period of time in a nonoperating mode under stated environmental conditions.

(4) **Launch and Flight Reliability (LFR).** The probability a munition, available for commitment to the launch sequence, will

respond to a valid launch command and successfully complete the launch and flight with delivery of a given warhead within accuracy requirements. This term includes a combination of operational suitability and effectiveness data.

(5) **Mean Mission Duration (MMD).** The average interval of time over which a system is expected to operate without mission failure.

(6) **Mean Time Between Critical Failure (MTBCF).** The average time between failure or unacceptable degradation of essential system functions. Essential system functions are those which must be operational if the mission is to succeed. MTBCF should consider software as well as hardware failures. Separate calculations should be made for software, hardware, and composite MTBCF. The following formula applies:

$$\text{MTBCF} = \frac{\text{total operating hours}}{\text{number of critical events}}$$

MTBCF is a major parameter of weapon system reliability.

(7) **Mean Time Between Downing Events (MTBDE).** A measure related to availability: the total number of system life units divided by the total number of events in which the system becomes unavailable to initiate its missions during a stated period of time.

(8) **Weapon System Reliability (WSR).** The probability a system will complete a specified mission, given the system was initially capable of performing that mission. WSR is a measure of system reliability as it affects the mission and includes the effects of both hardware and software critical failures (faults). WSR excludes operational effectiveness factors such as probability of kill, circular error probable, fault detection probability, and other measures of capability. WSR calculations are oriented toward specific mission scenarios and require the identification of mission length by mission phase, mission essential systems/subsystems by mission phase, and the life units of the systems/subsystems during each mission phase.

b. **Logistics-Related Reliability.** Reliability measures selected to account for or address all incidents that require a response from the logistics system. Logistics-related reliability may be further subdivided into maintenance-related reliability and supply-related reliability.

(1) **Maintenance-Related Reliability.** Mean time between maintenance (MTBM) is the primary measure of logistics reliability.

To obtain additional insight into the system under test, a maintenance action can be categorized as caused by inherent malfunction, induced malfunction, or no defect. Separate computations of MTBM (inherent), MTBM (induced), and MTBM (no defect) may be made in addition to total MTBM. MTBM is the total time in hours (for example, operating, flight, or possessed) divided by the total number of maintenance (base-level on-equipment) events for a specified period of time. (See AFLCR 66-15 for a discussion of the relationships between types of maintenance events and how-malfunction/action-taken-codes.) Expressing the time interval in terms of flying or operating hours is useful for systems that fail in use. Mean sorties between maintenance (MSBM) is more meaningful for systems whose failure is based on operating cycles, e.g., startup failures in a computer system or landing gear malfunctions. Although the number of sorties is not exactly equivalent to the operating cycles, the use of MSBM will lend insight to failures of a cyclic nature. It is important MTBM not be confused with the contractual term MTBF. MTBF is normally computed using only inherent failures or a subset of inherent failures. The AFLC data system which tracks historical MTBM performance is the DO56, Product Performance System.

(2) Supply-Related Reliability:

(a) Mean Time Between Demand (MTBD). A measure of system reliability related to demand for logistics support. It is the total number of system life units divided by the total number of item demands on the supply system during a stated period of time. AFLCR 57-4, Recoverable Consumption Item Requirements System, defines the demands. The AFLC data system which tracks historical MTBD performance is the DO41, Recoverable Consumption Item Requirements System.

(b) Mean Time Between Removal (MTBR). MTBR is equal to the total number of system life units divided by the total number of items removed from that system during a stated period of time. This term excludes removals performed to facilitate other maintenance and removals to accomplish time compliance technical orders.

10-6. System Reliability Models:

a. System reliability models visually and mathematically describe the relationship between the reliability of system components and the resulting system reliability. A reliability block diagram or structural model provides a visual representation, whereas a

mathematical model provides an analytical tool to calculate quantitative reliability values.

b. The following notation is used in the discussion of reliability models.

R_s = reliability of the system

R_i = reliability of the i^{th} subsystem

$Q_s = 1 - R_s$ = unreliability of the system

$Q_i = 1 - R_i$ = unreliability of the i^{th} subsystem

Π = "product of" (Note: This operator is used in the same fashion as Σ for summation, but it indicates multiplication rather than addition.)

c. The following discussion assumes all subsystems function independently from one another; that is, failures of different subsystems are statistically independent of each other. For some systems, this represents a realistic assumption; for others, it does not. The reliability analysis for dependent subsystems is significantly more complex. Independent operation, practically speaking, means a failure of one system will not cause a change in the failure characteristics of other subsystems.

(1) Series Model. When a group of components or subsystems is such that all must function properly for the system to succeed, they are said to be in series. A system consisting of a series arrangement in subsystems is illustrated in the following block diagram:



The mathematical model is:

$$R_s = R_1 R_2 \dots R_n = \prod_{i=1} R_i$$

(2) Redundant Models. The mission reliability of a system containing independent subsystems can usually be increased by adding redundant subsystems. The incorporation of redundancy into a system design and the subsequent analysis and assessment of that design is a complex task and will not be addressed here in detail (see RADC's reliability engineers toolkit for a more complete discussion). Our discussion will consider only simple active redundancy. In this type of redundancy, all the operable subsystems are functioning, but only one is needed

for satisfactory performance. There are no standby subsystems, and no repair is permitted during the mission. Such a system is illustrated in block diagram form as:

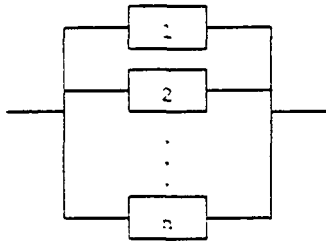

The mathematical model is:

$$Q_s = Q_1 Q_2 \dots Q_n = \prod_{i=1}^n Q_i = \prod_{i=1}^n (1 - R_i)$$

$$R_s = 1 - Q_s = 1 - \prod_{i=1}^n (1 - R_i)$$

(3) Mixed Models:

(a) A system configuration that is often encountered is one in which subsystems are in series, but redundancy (active) is applied to a certain critical subsystem. A typical block diagram follows:

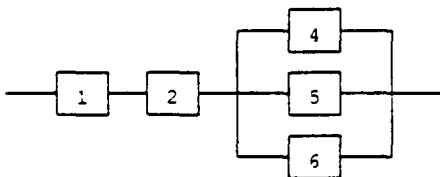

(b) This model (or any mixed model) is characterized by working from low to high levels of assembly. In this case, the equation for simple active redundancy which requires at least one of components 4, 5, or 6 to function can be applied:

$$R_{4,5,6} = 1 - (1 - R_4)(1 - R_5)(1 - R_6)$$

(c) The redundant configuration of 4, 5, and 6 can be then represented by a single block on the diagram.

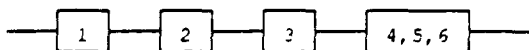

Now the equation for a series model can be applied:

$$R_s = R_1 R_2 R_3 R_{4,5,6}$$

$$R_s = R_1 R_2 R_3 [1 - (1 - R_4)(1 - R_5)(1 - R_6)]$$

(4) Functional Models:

(a) The redundant and mixed models series mentioned above are hardware-oriented in that they display hardware capabilities. In some cases, it is desirable to model a system from a functional standpoint. As an example, the functional reliability block diagram for a fighter aircraft is shown below:

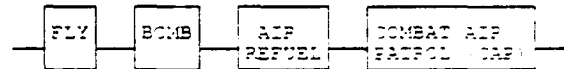

(b) Note this concept addresses mission-essential functions but in no way implies how these functions will be accomplished. Generally, the functional model is helpful in the program formulation stages of a program when specific hardware information is not necessary and frequently not desired. This type of model can provide a useful transition from operational requirement to engineering specification.

10-7. Statistical Test Design:

a. Test Design:

(1) One of the underlying purposes for reliability testing is to determine the aging characteristics of the item so inferences can be made as to how the item might perform during the execution of a mission. This is usually done by collecting data during OT&E and using it to estimate reliability parameters. By evaluating the parameters on a few test items, inferences can be drawn on how a fleet of items will, on the average, respond to required operations.

(2) There is a wide range of test structures or procedures used to learn about item or system failures and their frequency of occurrence. A statistical test design results from the specification of the conditions to be used, the definition and categorization of test events (or failures), the items of data to be collected, and the methodology to be used in evaluating the resulting data. If the reliability analyst has little or no influence on the specification of the test conditions, the analyst may be forced to adapt analysis techniques resulting in less rigorous evaluation methods. Although there are many types of reliability testing methods, in general, reliability testing before and/or during OT&E is concerned with developmental or acceptance type testing. These tests are used for estimating reliability parameters and deciding whether the parameters have reached an acceptable level at a certain degree of confi-

dence at the particular stage of system acquisition, i.e., meets threshold, goal, or contractual values.

b. Statistical Test Design Approach. Most test designs involve the determination or estimation of the parameters of an underlying time to failure distribution. The most common time-to-failure distribution used in reliability testing is the exponential distribution, although some cases are better represented by other distributions, such as the Weibull or Normal. In OT&E, especially in the preliminary or planning phases of reliability test design, an exponential distribution is frequently assumed for analysis purposes. If sufficient data are collected during the OT&E, and if time and resources permit, further analysis of the underlying time to failure distribution should be made.

c. Test Planning Considerations:

(1) Determining the test item sample size and test time must be done far enough in advance of the testing to include the resources in the test program outline and ultimately to allow the SPO to identify the funds required in the budget cycle. Inadequate sample size can easily negate the validity of reliability test results.

(2) Hypothesis testing can be used once the time to failure distribution has been assumed or estimated. The process involves the determination of a null hypothesis to be tested and an alternative hypothesis which will be assumed true if the null hypothesis is rejected. The sample size or test time determines statistically the risks associated with such testing. There is a risk of rejecting the null hypothesis when it is in fact true and a risk of accepting the null hypothesis when in fact the alternative hypothesis is true. For OT&E, however, the number of test assets as well as the length of the test period is likely to be constrained because of cost considerations. Tradeoffs between the risk levels can be made, but the required sample size becomes larger for a higher degree of certainty of making the correct decision. The test design should state the risk levels used for the hypothesis test.

(3) Early communication of reliability test requirements must be emphasized between AFOTTEC, the SPO, and the using command. These communications should result in a specification of contractual reliability consistent with operational reliability levels and an acceptable risk level to the accept or reject decision. In many cases, the reliability and risk specifications of the SPO or using command would require an unreasonable total test time and/or number of test assets. When this situation occurs, the

approving authority (Air Staff or OSD) must reduce the required confidence level and/or required reliability level or increase the test funding for more time and/or assets. In any case, the approving authority should have a concrete understanding of what the reliability testing can determine, given various tradeoffs between test time, reliability specifications, and levels of confidence in reliability predictions. Tradeoffs between demonstrated reliability and total test time required at various confidence levels can be plotted. Many examples of test design specification as well as a much more detailed discussion of hypothesis testing, sample size, level of confidence calculations, and parameter estimation are provided in the DOD Primer DOD 3235.1-H, Test and Evaluation of System Reliability, Availability, and Maintainability.

(4) The selection of MOEs for reliability should be based on the terms found in AFP 57-9 and the ORD.

(5) WSR should be calculated for each type of mission and may be used to accomplish a comprehensive mission effectiveness analysis. For complex systems, modeling is required to estimate WSR. However, for simple systems, WSR is often calculated using the following formula:

$$WSR = e^{-\lambda t}$$

where

$$\lambda = \text{failure rate} = \frac{1}{MTBCF}$$

t = estimated mission length

e = the base of the natural logarithm (2.71828)

NOTE: This formula assumes a constant failure rate (i.e., exponential distribution). If this assumption is invalid, other probability distributions will be used.

(6) Incoming inspection acceptance rate is an MOE peculiar to munition/missile programs. All munitions/missiles require an incoming inspection to check for damage and serviceability when they are first received at a base. The inspection may vary from a visual inspection of containers to a full functional checkout on a test set. The incoming inspection acceptance rate is the percent of munitions/missiles that pass the incoming inspection. Incoming inspection procedures are normally established and well documented by the time a test program starts because of the inherent hazards as-

sociated with transporting and handling munitions.

(7) Dormant reliability is also peculiar to munitions/missiles programs. These systems usually spend the majority of their life in storage. The current trend toward "wooden rounds" (systems which are designed to require no maintenance) also increases the importance of dormant reliability, since there will be no capability to verify system status before use. Unfortunately, dormant reliability is extremely difficult to measure during IOT&E because of the limited time and test assets available. The primary effort during IOT&E should be devoted to determining contractor and SPO design efforts and test programs to ensure reliability in the dormant state. For more discussion of this topic, see attachment 2.

(8) Data requirements for reliability consist of the following elements and sources:

(a) Elements. The data elements are typically the same for IOT&E and FOT&E.

1. Mission length.
2. Number of critical failures.
3. Number of maintenance events.
4. Mission essential subsystem list.
5. Work unit codes.
6. Number of sorties.
7. Operating hours.

(b) Sources. Data sources will depend on the testing environment.

1. During IOT&E, SEDS may be used to collect data elements. A joint reliability and maintainability evaluation team (JRMET) is normally formed and chaired by the system program office (SPO) to categorize maintenance events and identify critical failures. SEDS is structured to allow OT&E and DT&E interpretations of maintenance events to be reflected in the data base. If SEDS is unavailable or inappropriate, a tailored data collection system must be developed.

2. During FOT&E, the MDC system is typically used to collect maintenance data. MDC documentation, along with crew debriefing forms, is then reviewed to identify critical failures. The number of flying hours/sorties may be extracted from MMICS. The AFOTTEC OMNIVORE data system may be used to maintain the data base.

d. **Analysis of Test Results.** Whether or not a statistically significant reliability test plan was formally structured before undergoing the actual OT&E, data concerning the frequency and type of system failures during the test period will have been generated. If a reliability test plan was fully structured and adhered to during the test, the computation of whether the system meets

or exceeds required reliability values is straightforward. In many cases, insufficient test time and/or assets under test will limit what can be confidently said about the reliability. In those cases, simply reporting the observed reliability under various definitions, along with some estimation of confidence limits around the mean, may be all that can be accomplished analytically. As an extreme example, if one were to try to estimate the dormant reliability of a missile for which 27,108 hours of ground inactive test time was accumulated and for which one failure was observed, an 80-percent confidence interval for reliability would range from 6,969 to 257,288 hours. When little or no meaningful reliability data are available, the emphasis of the reliability assessment should shift from quantitative to qualitative.

10-8. The Need for Projection Capability During OT&E - Background:

a. The initial design for a complex system will invariably have significant reliability deficiencies that could not be foreseen in the early stages of the design effort. These immature designs may be subjected to a structured test program to identify problems so improvements can be made. Any improvement in system reliability, i.e., reliability growth, will depend on the number and effectiveness of system design improvements/changes. An ultimate goal of a reliability growth program is to meet or exceed system reliability requirements as outlined by the user.

b. Point or interval estimates of reliability, calculated from current and past observations, can provide an overall measure of reliability performance and can be used as a management indicator. However, during operational test and evaluation of systems in the acquisition process, measured reliability characteristics, in and of themselves, do not provide reasonable indications of expected future system reliability. Expected future reliability predictions must be made in the context of expected future system characteristics (design and use). The predictions must be continuously refined as the system matures and test data are replaced by more operationally representative data.

c. Three types of reliability estimates can be defined:

(1) Demonstrated or observed reliability estimates are those obtained directly from the test program.

(2) Current (instantaneous reliability estimates are those (vertical) adjustments to demonstrated reliability by a growth factor. The growth factor accounts for system design

improvements to correct identified problems.

(3) Projected reliability estimates are those (horizontal, or horizontal and vertical) adjustments which extend the current reliability estimate forward in time. These estimates assume a continuous process of system design improvements to correct identified problems and problems remaining in the system. (Reference MIL-HDBK 189, Reliability Growth Management.)

10-9. Application of Projections. Confusion has arisen regarding AFOTTEC's application of reliability growth theory to the test and evaluation process. Some people have been under the impression since OT&E thresholds are stated in terms of user requirements for a mature (IOC plus 2 years in most cases) system, AFOTTEC compares results demonstrated during OT&E to mature system requirements when assigning a rating. Actually, reliability values measured during OT&E are projected to maturity using accepted reliability growth theory before being compared with user requirements for a mature system. Thus, test ratings are based on projections of a system's expected reliability rather than the actual measured OT&E experience. Note: Accepted practice is to report both the reliability observed during OT&E and the projected reliability.

10-10. Reliability Growth and Tests:

a. Reliability Improvement. As highlighted in MIL-STD 785, testing does not improve reliability. Only corrective actions that prevent the recurrence of failures in the operational inventory actually improve reliability. In most cases, this will require additional funding for equipment or design changes and a retest to evaluate the changes.

b. Reliability Growth. DOD policy states reliability growth is required during full-scale development, concurrent development and production (where concurrence is approved), and during initial deployment. Predicted reliability is stated as a series of intermediate milestones, with associated goals and thresholds, for each specified parameter for each of those phases. A period of testing is scheduled in conjunction with each intermediate milestone. Approved reliability growth requirements are assessed and enforced at decision milestones.

c. System Reliability. This testing philosophy utilizes the test-analyze-fix-test (TAFT) procedure as the basic catalyst in achieving system reliability growth. The goal of a reliability growth program, and, indeed, the entire test program, is to increase system reliability to stated requirement levels by

eliminating, or reducing, a sufficient number of inherent system failure modes.

d. Growth Program. A successful system reliability growth program depends on several factors. First, an accurate determination must be made of the current system's reliability. Second, a test program must be planned which subjects the system to test exposure and stress levels adequate to uncover inherent failure modes and to verify design modifications. Third, the program manager must address the availability of test schedule and resources required to support the TAFT procedures.

e. Growth Rate. To adequately control factors inherent in the reliability growth throughout the test program. This is accomplished by periodically assessing system reliability (e.g., at the end of every test phase) and comparing the current reliability to the planned level of achievement for that point in time. These assessments provide the necessary data and visibility to support necessary corrective management initiatives. The rate at which reliability growth occurs (i.e., the growth rate) provides the primary process-oriented measure for assessing a system's potential for achieving mature system reliability.

f. Types of Development and Production Reliability Testing. Reliability test programs serve three objectives: (1) disclose deficiencies in item design, material, and workmanship; (2) provide measured reliability data as input for estimates of operational readiness, maintenance manpower cost, logistics support cost, etc.; and (3) determine compliance with quantitative reliability requirements. Four types of reliability tests of interest to T&E personnel are (1) environmental stress screening (ESS), (2) reliability development/growth testing (RDGT), (3) reliability qualification tests (RQT), and (4) production reliability acceptance tests (PRAT). The ESS and RDGT are classified as engineering tests; RQT and PRAT are classified as accounting tests.

(1) **Environmental Stress Screening (ESS).** ESS is a test, or a series of tests, specifically designed to disclose weak parts and workmanship defects for correction. It should be applied to parts, components, subassemblies, assemblies, or equipment (as appropriate and cost-effective) to remove defects which would otherwise cause failures during higher level testing or early field service. The test conditions and procedures should be designed to stimulate failures typical of early field service, rather than to provide precise simulation of the operational life profile. These tests should be considered an early portion

of reliability development/growth testing. They must be conducted early in development to ensure time and resources are available to correct the deficiencies they disclose and to verify the corrections.

(2) Reliability Development/Growth Testing:

(a) RDGT is a planned, prequalification, test-analyze-fix process in which equipments are tested under actual, simulated, or accelerated environments to disclose design deficiencies and defects. RDGT provides a basis for early incorporation of corrective actions and verification of their effectiveness, thereby promoting reliability growth.

(b) Predicted reliability growth must differentiate between the apparent growth achieved by screening weak parts and workmanship defects out of the test items and the step-function growth achieved by design corrections. The apparent growth resulting from ESS does not transfer from prototypes to production units; instead it repeats in every individual item of equipment. The step-function growth does transfer to production units that incorporate effective design corrections. Therefore, RDGT plans should include a series of test periods and each of the test periods should be followed by a "fix" period (step-function growth). RDGT should be conducted using one or two of the first full-scale engineering development items available.

(3) Reliability Qualification Test. RQT is intended to provide the government reasonable assurance that minimum acceptable reliability requirements have been met before items are committed to production. RQT must be operationally realistic, with predefined criteria to limit the risk the item may have a true reliability less than the minimum acceptable reliability. RQT is required for items newly designed, have undergone major modification, and have not met their allocated reliability requirements.

(4) Production Reliability Test (PRAT). PRAT is intended to simulate in-service evaluation of the delivered item or production lot. It must be operationally realistic and can consist of a normal test, an overload test, and/or a mission profile cycling test that duplicates or approximates the conditions expected in service.

g. Test Realism. A test is realistic to the degree that test conditions and procedures simulate the operational life/mission/environmental profile of a production item. Realistic testing can disclose deficiencies and defects that otherwise would be discovered only after an item is deployed. Test realism must be a primary consideration in every

reliability test. Establishment of realistic test conditions and procedures requires a knowledge of the life profile from factory to final expenditure/retirement.

h. Integrated Testing. It is DOD policy that reliability and environmental stress tests can be combined as far as practical. For example, mechanical, hydraulic, pneumatic, and electrical equipment are usually subjected to three qualification tests: performance, environmental, and endurance or durability. The integration of these separate tests into a more comprehensive reliability test program can avoid costly duplication and ensure deficiencies are not overlooked as they often are in the fragmented approach.

i. Combined Environmental Reliability Test (CERT):

(1) Studies have shown approximately one-half of field failures are environment induced. These studies also have shown MIL-STD environmentally based tests used for equipment qualification may not give realistic assessments of an equipment's reliability in its operational environment. Further analysis of environmental data shows the environmental conditions of temperature, humidity, altitude, and vibration do not generally remain constant throughout an aircraft's or missile's mission. Therefore, the relationship between aircraft (or missile) flight conditions and the operational environment of the aircraft (or missile) and its avionics are of primary concern. Environmental configurations in a test scenario should be presented in a time sequence similar to the environmental conditions experienced by an operational aircraft or missile. This concept of providing laboratory test conditions representative of the field is called combined environmental reliability test (CERT).

(2) CERT is a series of laboratory tests that attempt to duplicate flight environmental conditions by using mission profile tests. Combinations of environmental conditions characteristic of those that occur during a typical aircraft mission are put together in a test sequence. This involves the simultaneous simulation in a test chamber of the temperature, humidity, altitude, vibration, and cooling air mass flow into a time history sequence as if the test item were in actual flight. Thus, the behavior of the equipment in this laboratory test should closely approach its field performance. A high degree of correlation exists between CERT and field experience in terms of failure rates and modes. CERT, used in conjunction with a test-analyze-fix growth approach, can be very effective for early identification of deficien-

cies.

(3) Although CERT is a reliability test used by the developer during the system's acquisition, AFOTTEC should make maximum use of CERT-generated data for the system's evaluation. CERT, if applied by the developer during the system's acquisition, may provide the OT&E community with a cost-effective tool for identifying deficiencies and verifying their correction.

j. Reliability Growth Concepts:

(1) Idealized Growth:

(a) For a system under development, reliability generally increases rapidly early on and at a much slower rate toward the end of development. It is useful at the beginning of a development program to depict the growth in reliability as a smooth curve which rises at slower and slower rates as time progresses. This curve, known as the idealized growth curve, does not necessarily convey how the reliability will actually grow during development. Its purpose is to present a preliminary view of how a program should be progressing in order to realize the final requirements.

(b) The development testing program will usually consist of several major test phases. If we divide the development testing program into its major phases and join by a smooth curve the proposed reliability values for the system at the end of these test phases, the resulting curve represents the overall pattern for reliability growth (see figure 10-1). This idealized curve is very useful in quantifying the overall development effort and serves as a significant tool in the planning of reliability growth. One model for the idealized growth curve is the Duane Growth Model. The T&E Primer, DOD 3235.1-H, contains an example of how to construct an idealized growth curve using the Duane Growth Model.

(2) Planned Growth:

(a) Reliability growth planning is done early in the development program, before hard reliability data are obtained, and is typically a joint effort between the program manager and the contractor. AFOTTEC should participate in this effort to ensure we have the necessary interim measurement points for test. The objective of growth planning is to determine the number and length of distinct test phases, whether design modifications will be incorporated during or between distinct test phases, and the increases in reliability necessary to ensure the achieved reliability remains within sight of the idealized growth values.

(b) The planned growth curve displays, in graphic terms, how the producer plans by

stages to achieve the required reliability. The curve is divided into portions which represent the different test phases and depicts increases in reliability resulting from design improvements. The idealized curve serves as a guide for the preparation of the planned curve.

(c) As mentioned earlier, the planned growth curve should display how reliability is expected to grow, usually as a result of incorporating design modifications or changes to the manufacturing process. These modifications may be incorporated during the test phase, resulting in a smooth gradual improvement in reliability, or at the end of the test phase, resulting in a jump in reliability from the end of one test phase to the beginning of the subsequent test phase.

(d) Figure 10-1 presents a planned growth curve which illustrates the effect on reliability of design improvements incorporated during, and at the completion of, the various test phases. Delayed fixes are incorporated after each of the first three test phases. Fixes are incorporated during all of test phase 2 and early in test phase 3. Fixes are incorporated during the final test phase and the time between failures grow to the required specified value. It is not a good practice to allow for a jump in reliability at the end of the final test phase even though fixes may be incorporated, since there is no test time available to determine the impact of these fixes.

k. Caution Regarding Reliability Growth:

(1) It cannot be overemphasized that testing, in and of itself, does not cause reliability growth. The critical element of a growth program is a comprehensive plan to analyze failures and implement design modifications to eliminate or reduce those failures. Good planning and adequate funding are the necessary catalysts which bring about reliability growth.

(2) Operational testers must guard against estimating mature system reliability by using only the mathematical models as a basis for their projections. Considerations such as program funding, adequate test time and resources, and a commitment on the part of program managers to implement design modifications are critical in any assessment of system reliability at maturity. If design modifications stop at the end of the operational testing phase, reliability will not continue to improve. Reliability growth should only be forecast when a defined, funded program exists to allow growth to occur. The RMMP (see paragraph 10-2) is the source document for describing the relia-

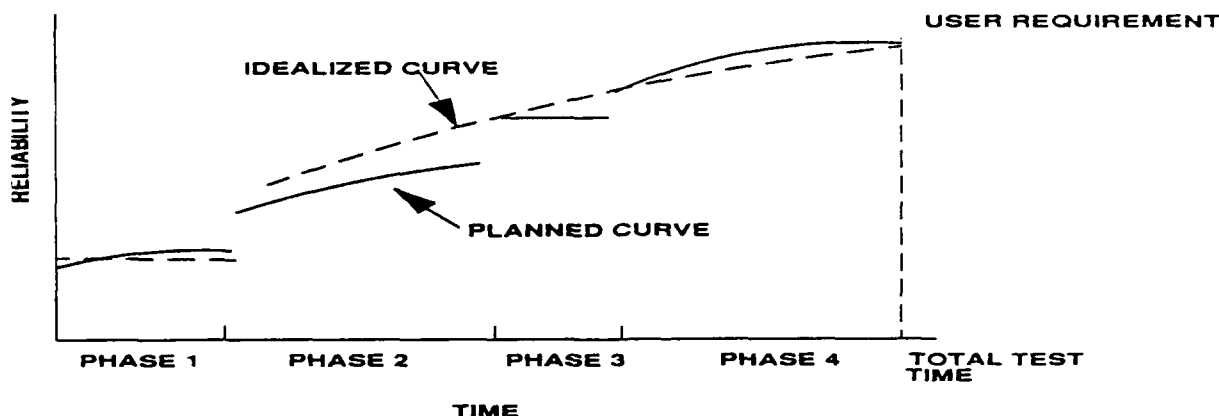

Figure 10-1. Example of a Planned Growth Curve and Corresponding Idealized Curve

bility growth program for the system under test.

10-11. Reliability Evaluation:

a. Logistics reliability is usually evaluated by analyzing MTBMs to determine their effect on the ability of the support system to respond to all failures/maintenance events under the defined operational and support concepts using programmed resources and to determine the effect of logistics reliability on the system's capability to meet mission requirements. Additionally, the quantitative and qualitative data are analyzed to identify those subsystems/LRUs demonstrating reliability below the required or expected level, the causes for poor reliability, and those subsystems/LRUs which have an adverse impact on safety and man-hour consumption. The results of the analysis are used to determine the logistics reliability impact on the system's availability and to assist in the evaluation of logistics supportability.

b. Mission reliability data are analyzed to assess weapon system reliability (WSR) and to identify deficiencies and their impact on mission success. MTBCF will be computed for subsystems/LRUs and aggregated at the system level for calculating a probability of nonfailure from the start of a mission until mission termination. Analysis is also performed to determine which subsystem can be improved to yield the largest increase in the probability of a failure-free mission.

10-12. Lessons Learned:

a. There may be no requirement for the contractor to provide R&M data to Air Force agencies, thereby limiting the amount of data available to AFOTEC test personnel during OT&E. The contract data requirements list

(CDRL) should be reviewed before test design activities begin.

b. The contractor is often not required to use an Air Force data collection system during test. Problems have arisen in the past because only relevant failures as defined by the contractor were included in the contractor's data base. In addition, the data are generally not auditable and the quality of the data may be questionable. Logistics and test managers should attempt to require, via the contract, the use of an Air Force data collection system, e.g., SEDS (AFR 800-18).

c. A common agreement on failure relevancy between the DT&E and OT&E personnel has not always been reached during a combined test because a JRMET was not established. It is often necessary for AFOTEC to take the initiative to cause the establishment of a JRMET.

d. Test results can be distorted if equipment is not operated under field conditions. To the extent possible, all systems supporting an article undergoing test should be used during test in the same way they would be used in the field. For example, equipment designed to be run on portable generators should be powered by the portable generators throughout the test. Secondary failure problems induced by generator power fluctuations may not be observed if the system is run on the base electrical system.

e. The maintenance data collection (MDC) system data may not provide a true reliability picture. Computer halts, for example, are not reported on some systems when downtime is less than 10 minutes. Test team personnel should ensure all factors that influence reliability are investigated.

f. Reliability reports are not always properly controlled. R&M data products by

themselves may not be classified, but when the result of the R&M evaluation depicts a system's operational capability, data may be classified. AFOTEC personnel should be familiar with the system's security classification guide.

g. There is often misunderstanding of the method used to compute weapon system or mission reliability. It is imperative AFOTEC, the SPO, and the user clearly understand the method, formulas, parameters, failure definition, etc., early in the test planning process.

h. OT&E on systems with high reliability present challenges to the test planner. Several methods are being investigated; however, a single policy in this area is lacking. Test planners should still develop an approach/concept and present it to the TSG. Among the methods studied are use of

Bayesian reliability test designs, redefining reliability requirements so testable criteria can be used/developed, and focusing the test design on maintainability versus reliability.

i. Use of confidence intervals/limits on reliability measurements is often misunderstood by those unfamiliar with statistical estimation. When used, they should be clearly explained so the decision maker will have an understanding of the information being provided in the final report. For example, it may be better to state how confident we are the user's requirement has/has not been met rather than giving a confidence interval about the observed (or projected) reliability measurement. There are no current policy or directives on applying confidence levels to projected reliability measurements.

Chapter 11

MAINTAINABILITY

11-1. General:

a. Maintainability and reliability are the two major system characteristics that impact the commonly used index—availability. While maintainability is important as a factor of availability, it also merits substantial consideration as an individual system characteristic. Maintainability is a factor of the design process and an inherent design characteristic that is quantitative and qualitative in nature and therefore lends itself to specification, demonstration, and tradeoff analysis.

b. In assessing maintainability, data elements such as maintenance time, direct maintenance man-hours, and system downtime are collected. The data are then reported as averages, either divided by some operational base such as flying hours, sorties, or maintenance events/actions, or categorized by systems to highlight the areas most needing attention. The key to effective maintainability assessment is first to measure maintainability and then to identify those factors which are influencing the results.

c. During an OT&E, quantitative and qualitative aspects of maintainability characteristics are addressed. Quantitative parameters for maintainability evaluation can be expressed as maintenance downtime per sortie, as a usage rate of manpower resources (for example, maintenance man-hours per flying hour), as the total required manpower (maintenance man-hours per operational unit), as a time to restore a system to operational status (mean downtime), etc. Qualitative aspects of maintainability include accessibility, serviceability, ease or difficulty of maintenance, safety, and human factors associated with maintenance actions. These factors affect the quantity, skill levels, and specialty codes of maintenance personnel and the test equipment required to maintain the system. Qualitative evaluations of maintainability are usually done by experienced maintenance technicians using subjective judgment and are supported by quantitative maintainability values.

11-2. Definitions and Concepts:

a. **Maintainability.** The measure of the ability of an item to be retained in or restored to a specified condition when maintenance is performed by personnel having specified skill levels, using prescribed procedures and resources at each prescribed level

of maintenance and repair (MIL-STD 721C). A commonly used working definition states maintainability is the inherent characteristic of a design that determines the type and amount of maintenance required to retain that design in, or restore it to, a specified condition.

b. **Maintenance.** All actions required to retain an item in, or restore it to, a specified condition. This includes servicing, diagnosis, repair, modification, modernization, overhaul, rebuild, test, reclamation, inspection, and condition determination.

(1) **Preventive Maintenance.** Systematic inspection, detection, and correction of incipient failures either before they occur or before they develop into major defects. Adjustment, lubrication, and scheduled checks are included in the definition of preventive maintenance.

(2) **Corrective Maintenance.** Maintenance performed on an unscheduled basis to restore equipment to satisfactory condition by correcting a malfunction.

(3) **Off-Equipment Maintenance.** In-shop maintenance performed on removed components, except complete aircraft engines.

(4) **On-Equipment Maintenance.** Maintenance accomplished on complete end items such as aircraft, trainers, support equipment, CEM equipment, complete round munitions, and complete aircraft engines.

c. **Maintenance Concept.** A description of the essential elements, requirements considerations, and constraints for support of a new weapon system or equipment in its intended operational environment. It is prepared IAW AFR 66-14 to be an integral part of the ORD required by AFR 57-1. The maintenance concept forms the basis for all logistics planning and, along with the operational concept, establishes the framework for design.

11-3. **Policy.** DODI 5000.2 and AFR 800-18 outline the policy for implementing and managing maintainability programs for systems, subsystems, and equipment. Maintainability is measured during the entire T&E effort. During DT&E, test conditions and procedures for verification demonstrations attempt to reflect the operational conditions as closely as possible. During OT&E, maintainability assessments include evaluating test results against criteria expressed in operational terms and evaluating logistics

supportability of the system against mission requirements.

11-4. Considerations in Planning Maintainability Assessment. An understanding of the principal elements of maintainability is essential to the evaluation planning process. The factors which affect the ability to perform maintenance are the design of the system, the technicians performing the maintenance, and the logistics support concept. Another factor which influences the quantitative maintainability measures is the frequency with which maintenance is required.

a. The system design, both hardware and software, affects the speed and ease with which maintenance can be performed. Examples of these effects are accessibility, visibility, interchangeability, and simplicity.

b. Maintenance personnel can have a significant impact on maintainability assessments. The considerations here include the experience of the technicians, training, skill level, supervision, techniques used, physical coordination and strength, number of technicians, and teamwork requirements. An effort should be made to construct a test team that is representative of an operational maintenance unit and in line with the maintenance concept of the system under test.

c. Some logistics support considerations that affect maintainability include technical data (TOs and manuals), support equipment, integrated diagnostics, and sparing concepts. These factors are evaluated separately under "logistics supportability" (chapter 3) and "integrated diagnostics" (chapter 13); however, they can affect repair times, downtimes, and manpower requirements. Since it is rarely possible to test with all the logistics support elements in place, adequate evaluation of maintainability may require simulation of the operational environment.

d. When calculating average downtimes, repair times and man-hours, the frequency with which different maintenance tasks are required can have a significant impact. This maintenance frequency is affected by equipment reliability and the preventive maintenance schedule. There should be sufficient test exposure to allow a variety of maintenance actions to be required during test, thereby achieving more accurate repair frequency, repair times, and troubleshooting times. These are some of the reasons maintainability demonstrations can only supplement and not replace operational testing. Demonstrations can be used to quantify maintenance times for tasks that will not be required during the course of the test. These will be discussed in further detail in section

11-10.

11-5. Maintainability Measures. The following paragraphs describe the various MOEs used to quantify maintainability. Selection of MOEs should reflect ORD requirements.

a. **Fix Rate.** Percent of aircraft which return "code 3" that must be repaired in a specified number of clock hours (AFP 57-9).

b. **Maintenance Personnel Per Operational Unit (MP/OU).** The number of maintenance personnel that will be required to support an operational unit (excluding depot level and other manpower that is excluded from maintenance planning factors) under specified operating and maintenance concepts. The user of this term needs to define the operational unit. The numbers of maintenance personnel can be computed through the use of simulation by operating command standards or maintenance man-hour per flying hour calculations (AFP 57-9).

c. **Maintenance Man-Hours Per Life Unit (Operating Hours, Flight Hours, Sorties) (MMH/LU).** The cumulative man-hours of maintenance expended in direct labor during a given period of time, divided by the cumulative number of end-item life units during the same time. The MMH/LU is expressed at each level of maintenance and summarized for all levels of maintenance combined. Corrective and preventive maintenance is included. Man-hours for off-equipment repair of replaced components and man-hours for daily operational checks can be included for some systems. The life unit must be clearly defined (AFP 57-9).

d. **Mean Active Maintenance Time (\bar{M}).** A common (not necessarily standard) term defined as the average elapsed time required to perform scheduled (preventive) and unscheduled (corrective) maintenance. It excludes logistics delay time and administrative delay time and is expressed as:

$$\bar{M} = \frac{(\lambda)(MRT) + (f)(\bar{MPT})}{\lambda + f}$$

Where λ is the corrective maintenance rate or failure rate, f is the preventive maintenance rate, MRT is defined in paragraph 11-5(g), and \bar{MPT} is the mean preventive maintenance time.

e. **Mean Downtime (MDT).** The average elapsed time between loss of mission capable status and restoration of the system to mission capable status (AFP 57-9). Downtime includes maintenance and supply (or logistics) delay time (LDT), administrative delay time (ADT), and actual on-equipment

repair (expressed as mean active maintenance time, \bar{M} , defined above). A simple expression for MDT is:

$$\text{MDT} = \bar{M} + \text{LDT} + \text{ADT}$$

MDT is significantly influenced by logistics support and maintenance management policy. Where such an impact is noted, its effect on MDT must be separated from system maintainability characteristics and reported. MDT should not be directly measured during IOT&E because support elements will not be representative of the intended operational environment. Instead, simulation should be used to calculate MDT.

f. Mean Man-Hours to Repair (MMR). The total corrective base level man-hours divided by the total corrective maintenance events for a given period of time.

g. Mean Repair Time (MRT). The average on- or off-equipment corrective maintenance time in an operational environment (AFP 57-9). MRT includes all maintenance actions required to correct the malfunction, including preparation for test, troubleshooting, removal and replacement of components, repair, adjustment, functional check, etc. MRT does not include maintenance or supply delays and elapsed time for preventive maintenance. Hence this index does not provide a complete measure of the total maintenance burden. MRT is similar to mean time to repair (MTTR) or mean corrective time (MCT), but is referred to as MRT when used as an operational term to avoid confusion with the frequently used contractual term of MTTR.

h. Mission Time to Restore Functions (MTTRF). A measure of mission maintainability. MTTRF is the total corrective critical failure maintenance time, divided by the total number of critical failures, during the course of a specified mission profile (MIL-STD 721).

i. Mean Time to Restore System (MTTRS). A measure of system maintainability related to availability and readiness. The total corrective maintenance time, associated with downing events, during a stated period of time. (Excludes time for off-equipment maintenance and repair of detached components.)

j. Mean Time to Service (MTTS). A measure of an on-system maintainability characteristic related to servicing that is calculated by dividing the total scheduled crew/operator servicing time by the number of times the item was serviced.

k. Turnaround Time (TAT). The maintenance time needed to prepare an aircraft

system for another sortie/mission. The time begins at engine shutdown or landing and includes servicing, preflight/postflight inspection delays, unscheduled maintenance, and reconfiguration activities.

l. Quick Turnaround Time (QTAT). QTAT is an indicator of the maximum surge sortie generation capability and is the shortest total elapsed time required to prepare an aircraft returning from one mission for another mission in the same configuration. Personnel, equipment, and expendables (such as munitions) will be pre-positioned. The munitions load may be changed provided reconfiguration is not required. Operational and maintenance policy can affect QTAT. Since quick turnaround procedures require typical maintenance procedures, special tests must be arranged. The assessment must consider comparison of the test environment to the intended operational environment. For multimission aircraft, more than one QTAT test may be required. QTAT may be associated with the term "integrated combat turnaround (ICT)." ICT is an authorized exceptional servicing operation for tactical aircraft during which the simultaneous fueling, munitions loading/unloading general servicing, and other specific maintenance actions are performed (TACR 66-5).

m. Mean Time to Perform Munitions/Missile Generation Functions. Mean time to repair, assemble, deliver, or load are direct time measurements used to determine the ability of the system to support user generation time requirements. The mean time to perform the various functions is calculated by dividing the total time required to perform each function (assembly, delivery, or loading) by the total number of times each function was performed during test. Criteria for these functions are normally contained in the system maintenance concept. These measurements are used as data for input to the system availability model if one is used.

n. Off-System Maintainability Indices. Off-equipment measures are particularly important if a system's maintenance concept involves extensive use of modular removal and replacement, since this type of concept transfers the maintenance burden to off-equipment maintenance. Off-equipment maintainability measures are essential to assess combat environment off-equipment repair and logistics capability to maintain the system. Off-equipment parameters could include time to repair at intermediate and depot levels or repair man-hours for off-equipment repair and indirect man-hours required to support the system. Other indices may be used as required to address the

total maintenance burden of the system.

o. Qualitative Maintainability Characteristics. Qualitative aspects of maintainability include accessibility, serviceability, ease of maintenance, safety, and human factor requirements. The intent is to identify the qualitative aspects of maintainability that significantly influence the quantitative measures of maintainability. Assessment of these aspects affords an opportunity to address a broad range of maintenance concerns and their interactive effect on maintenance resources.

11-6. Integrated Diagnostics. One aspect of maintainability that has received significant attention in recent system designs is integrated diagnostics. This includes both internal or automated diagnostic systems, referred to as a built-in test (BIT), and external diagnostic systems, referred to as technical documentation automatic test equipment (ATE), test sets, or off-line test equipment. Chapter 13 contains a detailed discussion of this area.

11-7. Maintainability Growth:

a. DODI 5000.2 states that maintainability growth is required during full-scale development, concurrent development and production, and during initial deployment. Predicted maintainability is stated as series of intermediate milestones, with associated goals and thresholds, for each contractually specified parameter for each of those phases. A period of testing is scheduled in conjunction with each intermediate milestone. A block of time and resources are scheduled for the correction of deficiencies and defects found during the testing to prevent their recurrence in the operational inventory. Approved maintainability growth requirements are assessed and briefed at decision milestones.

b. As with reliability, a successful maintainability growth program depends on a test program that subjects the system to test exposure adequate enough to uncover maintainability design deficiencies. This is usually accomplished through maintainability verification and demonstration activities. To achieve growth, the inadequate design features must be analyzed, modifications incorporated, and the modified system retested to verify the validity of the fix. It is this test-analyze-fix-test (TAFT) philosophy that is the basis for maintainability growth. However, there are other ways to improve maintainability. Good training (including hands-on experience) is one way to learn. As tasks are repeated a learning process occurs. This process can be easily modeled.

11-8. Tracking Maintainability Growth:

a. The objectives of growth tracking are to determine if growth is occurring and to what degree, to estimate the maintainability parameter values, and to formulate a projection of these values.

b. The program manager must establish contractual and mature operational maintainability threshold and goal values and maintain traceability throughout the acquisition process. These values are updated during the acquisition process and must be presented by the program manager at appropriate milestones. Usually the predicted maintainability growth is shown as series of intermediate points to be attained during the system acquisition.

c. During OT&E, the concept of quantifying maintainability growth is useful in determining whether or not mature operational requirements for maintainability can be achieved. System design changes for maintainability are intended to improve the time required to repair or restore an item to a specified condition. However, such changes may in fact degrade maintainability. Unlike reliability, there is no standard technique used to track maintainability growth based on developmental/operational test data with consideration given to planned design, procedures, and/or training improvements. At publication of this pamphlet, an effort to study maintainability prediction methods and adopt a set for use by AFOTTEC was under consideration. Results of the study will be published in future updates to this pamphlet. In the interim, the following approaches have been used:

(1) Compare tested system data with data from a similar fielded system. Use expert judgment to predict future maintainability of tested system.

(2) Use/modify methods described in MIL-HDBK 472, Maintainability Prediction.

(3) Vary maintainability related input to operational availability models/simulations to determine impacts (if any) of achieving (or not achieving) mature maintainability values.

(4) Formulate a progress function or learning curve based on the fact the time required to maintain an item drops as the total number of items maintained doubles.

11-9. Data Analysis:

a. Most data elements for maintainability MOEs are the same for IOT&E and FOT&E. Administrative and logistics delay factors may vary. During IOT&E, these delay factors must be estimated (e.g., from data on similar weapon systems); during FOT&E, they can usually be measured directly.

Common data elements are:

- (1) Turnaround times.
- (2) Number and type of different missions or system configurations.
- (3) Assembly, repair, and/or loading times.
- (4) Not-mission-capable hours.
- (5) Logistics delay times.
- (6) Administrative delay times.
- (7) Number of repair actions.
- (8) Number of flying hours.
- (9) Number of sorties.
- (10) Number of personnel performing tasks.
- (11) Questionnaires.

b. Data sources for maintainability are similar to those for availability and reliability.

c. The test team will generally collect repair data on failures during the test period in order to compute the quantitative parameters such as model output, MTTRS, and MRT. MTTRS or MRT is usually calculated for the system and each subsystem/LRU. The system MDT, while useful for determining system availability, does not adequately identify problem areas. Therefore, subsystem/LRU level MRT should be analyzed to highlight repair times that are inordinately high due to design or other characteristics, and to indicate undesirable trends. Administrative and logistics delay times and preventive maintenance times should also be examined for unusually high times or adverse trends. The distribution of the individual repair times can be determined by using histograms and goodness-of-fit tests. If limited data are available for statistical confidence, a lognormal distribution is usually assumed.

d. Qualitative maintainability data collected by the test team will be analyzed to identify problems with equipment design, installation, accessibility, or servicing. Special emphasis should be placed on equipment design problems that could lead to maintenance errors or safety hazards. Repair times that are excessive should be further analyzed to determine the primary cause. The results of these analyses are usually combined with the logistics supportability data for evaluation purposes.

11-10. Maintainability Demonstrations (M-demos). Maintainability demonstrations, or M-demos, are normally associated with DT&E. These are conducted by the system contractor to demonstrate compliance with specifications. M-demos can be used to acquire data during OT&E if done in the operational environment. M-demos performed

during OT&E, or operational M-demos, are "staged" maintenance events done in an operational environment to obtain quantitative maintainability information not otherwise available during OT&E. These are sometimes described as ease-of-maintenance demonstrations (removal and replacement of components or performance of tasks). Other potential M-demos can be performed by intentionally inserting faulty components into the system to assess troubleshooting and repair capability. This is especially important when testing highly reliable systems (test exposure small compared with expected mean time between failure). The logistics evaluation manager should decide on the method of acquiring the data through establishment of a formal requirement with the SPO to ensure a requirement is included in contract for acquiring data through the use of M-demos. The logistics manager should become familiar with MIL-STDs 470 and 471 and identify the test data requirements. Many of these M-demos can only be assessments, not evaluations. This is because they do not necessarily relate exactly to the frequency and mode of failures, and they do not give data on "induced" and "no defect" failures. The test team should use the approved integrated logistics support plan to identify the logistics support required. When performing M-demos, certain considerations apply. M-demos should:

a. Be clearly defined and scoped in the OT&E test plan.

b. Be coordinated with the implementing command.

c. Be performed at or near the end of operational test so as not to interfere with or alter the equipment under test.

d. Be conducted in an environment which simulates, as closely as possible, the operational and maintenance environment planned for the item (i.e., blue-suit maintenance with no contractor involvement). The environment should be representative of the working conditions, tools, support equipment, spares, facilities, and technical publications that would be required during operational service as described in the maintenance plan.

e. Be videotaped.

f. In conjunction with the ease-of-maintenance demonstration, the test team should use the approved integrated logistics support plan, when required and established by the contractor, scaled to the number of test items employed in the demonstration, to identify the logistics support required.

g. Ease-of-maintenance demonstrations should be videotaped.

11-11. Lessons Learned:

a. There may not be a requirement for the contractor to provide maintainability data to Air Force agencies, thereby limiting the amount of data available to AFOTEC personnel during test. Review contract deliverables before test planning activities, preferably before contract award, to determine AFOTEC accessibility to contractor data. See the AFOTEC LGOI on requests for proposal (RFP) as an aid in this review.

b. During early phases of test programs, the system may be maintained by contractor personnel or by a mix of contractor and blue-suit personnel. The contractor personnel may be documenting maintenance actions using their internal data collection system while the blue-suitors are using SEDS or the MDC system to document their maintenance actions. There is often no direct link between the system, which results in data loss. AFOTEC should make every attempt to establish a common data collection system.

c. A lack of common definition of maintainability terms among DT&E, OT&E, and contractor personnel has caused problems in the past. AFOTEC should insist on an early establishment of JRMET to set the ground

rules early in the test program.

d. Test results can be distorted if equipment is not maintained by maintenance personnel representative of using command personnel. Additionally, problems in handling large or heavy objects will be more apparent if personnel who are average in size and strength are used to support the system during test. Particular attention must be given to these areas to ensure accurate analysis and reporting.

e. Maintenance data collection may be inadequate during the early phase of test programs because a maintenance analyst is not available. This results in incomplete and less than meaningful data. AFOTEC should ensure that a maintenance analyst is assigned to the test team before the test starts.

f. Maintainability demonstrations may be conducted under conditions that are not representative of field conditions resulting in questionable data for OT&E purposes. AFOTEC personnel should try to influence the SPO to conduct the demonstrations under representative field conditions. At the very least, AFOTEC personnel should audit the data to determine their usefulness.

Chapter 12

SOFTWARE EVALUATION

12-1. Introduction. Software is an integral part of almost every weapon system. Because it crosses many disciplines, poorly designed software can render a weapon system ineffective and make the system difficult to support. The test methodologies in the following paragraphs were developed to determine the contribution of software to a system's operational effectiveness and suitability.

a. Software Effectiveness. Software effectiveness or performance evaluation (from an OT&E standpoint) is always done within the context of overall system performance evaluation in an operational environment. The evaluation of system functions, whether implemented through hardware or software, falls into the area of operational effectiveness. There are no upper-level, agreed-upon metrics that characterize the nature of software performance in its operational configuration; however, two software suitability indicators, software maturity, and software usability do provide insight into software's impact on mission performance. For instance, portions of the software maturity trend analysis provide system and subsystem level trend information about the progress of software performance, while a software usability evaluation provides information regarding the user-machine interface and the user-friendliness of the software. Thus in OT&E, software effectiveness focuses on software problems and the effects of those problems on system operation. The headquarters and test team software evaluation personnel provide consultation to other test team members in evaluating the contribution of software to system effectiveness and assist in defining test scenarios for the system that exercise known or suspected weak areas in system design.

b. Software Suitability. The Software Analysis Division's primary area of focus is on software suitability. Software suitability encompasses a number of software support activities and functions. Software maturity, software usability, and software supportability are important indicators of software suitability. Software supportability is a subset of software suitability and has four primary areas for evaluation: software maintainability, software support life cycle processes, software support resources, and software support risk assessment. Related areas of evaluation include spare computing

capacity, computer security, software reliability, and adaptive software suitability assessments. The details of each type of evaluation are provided below. A handbook has been published by AFOTEC/LG5 which provides detailed guidance on how to report the results of these evaluations.

12-2. Software Maturity Evaluation. Software maturity is a measure of the software's progress in its evolution toward satisfying all documented user requirements. Software maturity trend analysis can be useful in three areas: readiness for IOT&E, software suitability, and software effectiveness. It is a qualitative evaluation using software change trend data and assessing both the timeliness of the software changes and the ability of the software to evolve toward "error-free," effective software.

a. Method. This evaluation is conducted using the guidelines prescribed in AFOTECP 800-2, volume 6, Software Maturity Assessment Guide. As soon as software comes under formal configuration control, software change data should be collected by the program office. AFR 80-14 require these data be shared by all test organizations. All software changes (both failures or enhancements) are plotted cumulatively over time. Each change is weighted by a multiplier based on its severity (defined in DOD-STD 2167A, Defense System Software Development, appendix C). Also cumulatively plotted over time are the software changes implemented. Two other trend measures are also collected: the trend of the average time required to make changes and the trend of the average severity of changes being identified.

b. Data Requirements. The data requirements to perform this evaluation include software changes required, software changes implemented, problem severity, and completeness of testing. It is important the need for software maturity data be discussed at the TPWG and arrangements made to obtain it from the development contractor through the SPO. Reference attachment 8 for a copy of our generic data item description.

c. Evaluation. The test team deputy for software evaluation (DSE) and the headquarters software evaluation manager examine the curves produced from the software change data. In a mature system, the curve

of changes required should flatten to some steady state value, while the curve of changes implemented should converge with the curve of changes required (see figure 12-1). This would show that fewer and less severe problems are being found and that software problems are being corrected faster than they are being discovered. Trend data on the time required to make software changes will indicate how well the development contractor is able to make critical software changes while the average severity trend will indicate whether or not major software problems are still being identified or if, indeed, the operational software is truly maturing. When examining the curves, test completeness must also be considered or the maturity data may be misinterpreted. Figure 12-2 is a composite presentation of the software maturity trend information used in test readiness determinations, test report briefings, and in AFOTEC final reports. In determining software's readiness to support IOT&E, maturity trends are used to identify the presence of a stabilized software baseline and an absence of mission critical software problems. Software suitability information is in the form of how accurately and efficiently software problems and changes are developed and implemented, while software effectiveness information centers on the identification of software changes and the corresponding impact on system functional capabilities.

d. Assessment Criteria. Qualitative. This evaluation is based on trend information, and there are no quantitative evaluation criteria.

12-3. Software Usability Evaluation. Software usability is a measure of the man-machine interface between the operator and the software. Software usability evaluates how easy the software is to use by a typical system operator. The evaluation examines the usability attributes of confirmability, controllability, workload suitability, descriptiveness, consistency, and simplicity. This evaluation is usually performed as part of a larger human factors evaluation but, under certain circumstances, may be a stand-alone OT&E objective.

a. Method. This evaluation uses the questionnaire in AFOTECP 800-2, volume 4, Software Usability Evaluator's Guide. The questionnaire is designed to be administered to operators who are experienced in using the operator-machine interfaces. Comments play an important role in the evaluation and the interviewer should also solicit comments from the operators.

b. Data Requirements. Requirements

to perform this evaluation include the questionnaire in AFOTECP 800-2, volume 4; answer sheets completed by the operators; and the operators' comments.

c. Evaluation. The results (numerical scores and histogram) of the questionnaire are analyzed along with the operator comments to qualitatively assess the usability strengths and weaknesses of the interface.

d. Assessment Criteria. Qualitative. There are no quantitative evaluation criteria for this evaluation.

12-4. Software Supportability. As mentioned earlier, there are four primary areas of focus that contribute to the overall assessment of software supportability: software maintainability, software support life cycle processes, software support resources, and software support risk assessment.

a. Software Maintainability Evaluation. The software maintainability evaluation focuses on the quality of the computer program source code, its associated documentation, and the overall design implementation with regard to facilitating the task of later changing the computer software. Software changes could be for the purpose of correcting errors, adding system capabilities, deleting functions, or modifying software to be compatible with hardware changes. The software maintainability evaluation measures the extent to which the software design, as reflected in the source code listings and documentation, has good maintainability characteristics. These characteristics include modularity, descriptiveness, consistency, simplicity, expendability, testability, traceability, convention, design, and organization.

(1) **Method.** A team of five software evaluators completes structured questionnaires contained in AFOTECP 800-2, volume 3, Software Maintainability Evaluation Guide, to evaluate software documentation, design implementation, and a representative sample of software source code (modules). These evaluators, usually from the supporting or using command, should be experienced software maintainers, typical of those which will have responsibility for software support of the system when the Air Force assumes software maintenance responsibility.

(2) **Data Requirements.** Data requirements to perform this evaluation are all deliverable software documentation; software source code listings; questionnaires contained in AFOTECP 800-2, volume 3; answer sheets completed by the evaluators; and the evaluators' comments.

(3) **Evaluation.** Evaluator answer sheets and comments are collected, scored, and

SOFTWARE MATURITY

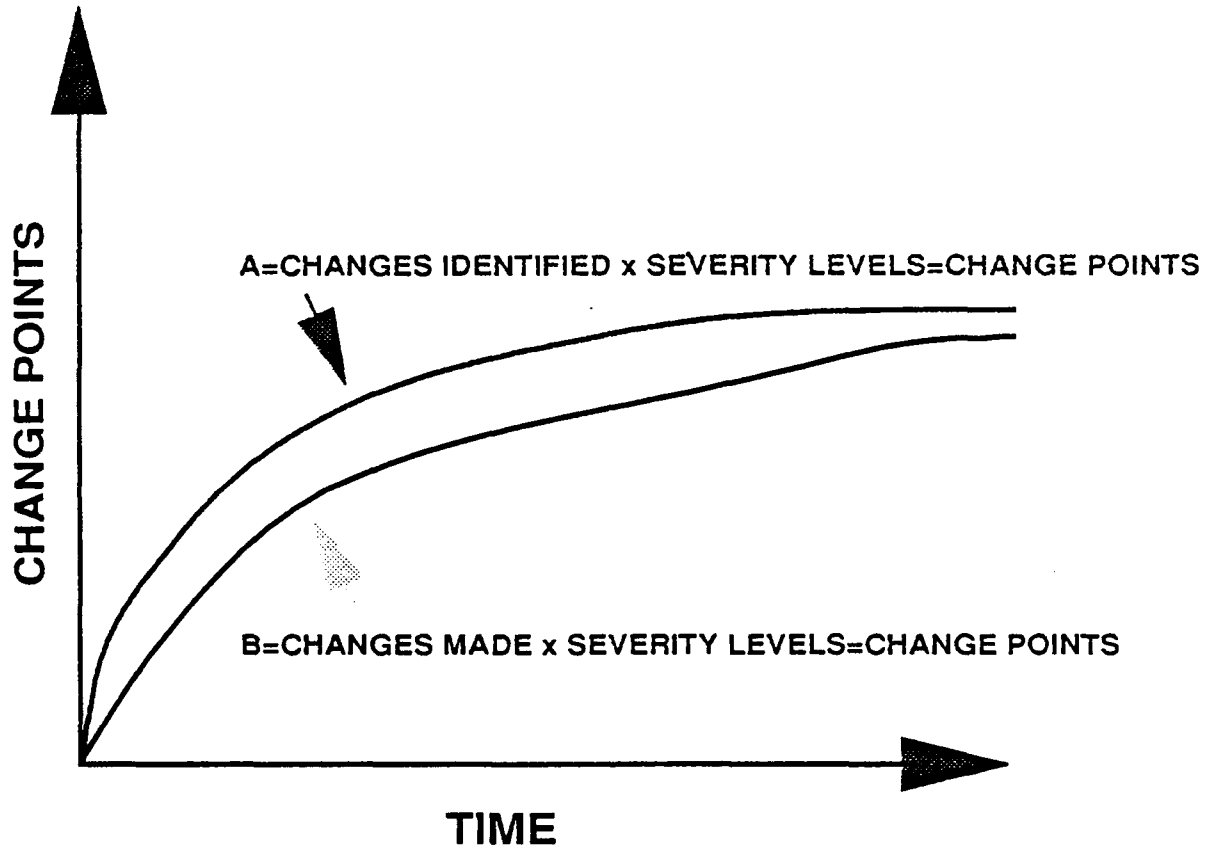

Figure 12-1. Software Maturity Concept

SOFTWARE MATURITY

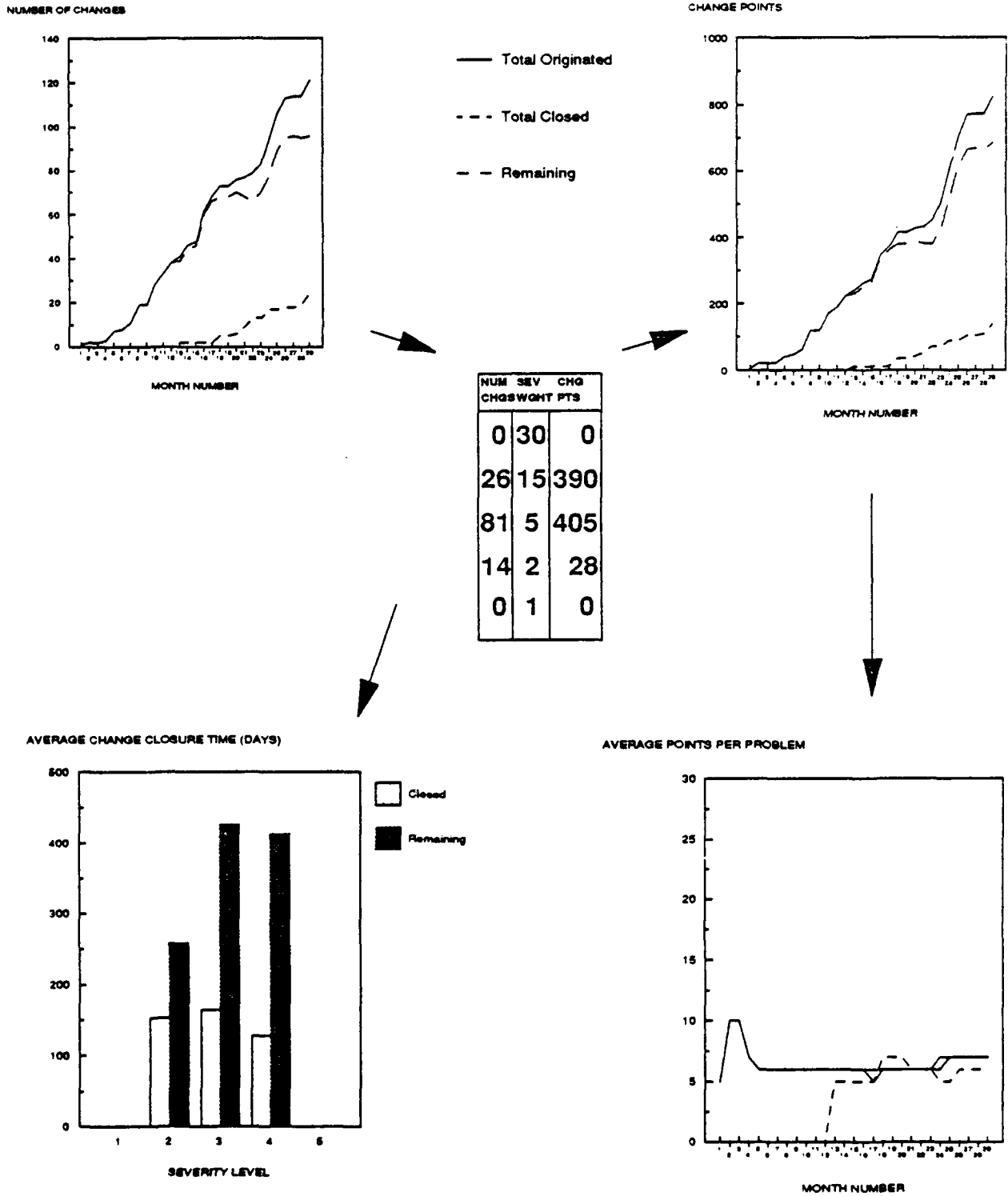

Figure 12-2. Software Maturity (Final Report)

compared to determine evaluation results. To determine the likelihood the software will be easily maintained or not, the average score from the questions is compared to a numerical threshold value of 3.5 (on a scale of 6 good to 1 bad). Scores less than 3.5 indicate problem areas needing further analysis. Histogram analysis of scores may also be used to understand and report the significance of the results. The DSE or headquarters software evaluation manager will then further examine detailed questionnaire results and comments to discover the strengths and weaknesses of the software's maintainability characteristics.

(4) Assessment Criteria. There are no quantitative evaluation criteria for this evaluation; although, on occasion, some using commands have stated the 3.5 numerical threshold as their operational requirement.

b. Software Support Resources Evaluation. Software support resources include the personnel, computer support systems, configuration management system, contingency plans, and software support facilities required by the depot support agency to accomplish software modifications. The goal of this evaluation is to assess the adequacy of the in-place or planned software support resources to satisfy user requirements for postdeployment software support.

(1) Method. The questionnaire in AFOTTECP 800-2, volume 5, Software Support Resources Evaluation Guide, is tailored for the particular system being evaluated. The questionnaire is administered by the DSE or software evaluation manager in one of two ways: using structured interviews or using designated software evaluators. If the structured interview method is used, the DSE or software evaluation manager interviews managerial and technical people and reviews software support documentation to gather information to subjectively answer the questionnaire. This method is most effective during the system planning and design stages. The software evaluator method uses a panel of software support resources experts to answer the questionnaire. This method is best suited for the actual operational stage of the software support resources.

(2) Data Requirements. Requirements to perform this evaluation include software support documentation, completed tailored questionnaires, and evaluator comments.

(3) Evaluation. The DSE or software evaluation manager reviews the completed questionnaire with the comments to determine the state of the software support resources. The results are used in a checklist fashion to identify deficiencies. The com-

ments are most important to this type of evaluation for providing insight into problem areas.

(4) Assessment Criteria. Qualitative. There are no quantitative evaluation criteria for this evaluation.

c. Software Support Life Cycle Process Evaluation. The software support life cycle process is the environment in which software and its support resources are procured, developed, operated, and supported. This evaluation was developed to determine the degree to which certain software development and support management procedures affect a particular system. The major elements of the software support life cycle process are software project and configuration management. Software project management includes planning, organizational structure, design and implementation methods, test strategies, and project interfaces. Software configuration management includes the control of software changes through technical and administrative actions. The evaluation of the software support life cycle process is applicable to all phases of a program. For early operational assessments, the software development process is a major focus of the software evaluations. This evaluation is structured to determine if significant problems are occurring which could impact the readiness of the system to meet its OT&E schedule. For systems in OT&E, this evaluation is geared toward the management process being implemented by the depot software support agency.

(1) Method. The DSE or software evaluation manager uses the questionnaire contained in AFOTTECP 800-2, volume 2, Software Support Life Cycle Process Evaluation Guide, to accomplish this evaluation. This questionnaire was not meant to be completed in one sitting, but is to be completed over a period of time throughout the development and operational test and evaluation cycle. The questionnaire is used as a guide or checklist when reviewing program documentation (e.g., PMP, TEMP, CRLCMP, etc.) or attending meetings (TPWG, CRWG, PDR, CDR, etc.). Specific questions are then answered based on information gathered from the documentation or the meetings. Comments are written after each question justifying the evaluation. The evaluation is updated over time as situations change. For systems in OT&E, the questionnaire helps guide an assessment of the computer resources life cycle management plan (CRLCMP) and other evolving documents. The final element of the evaluation, however, is an assessment of the eventual software

support agency management process needed to design, implement, and control post-deployment software changes.

(2) **Data Requirements.** Requirements to perform this evaluation include program documentation, information from meetings, life cycle management plans, and the completed questionnaire with supporting comments.

(3) **Evaluation.** The DSE or software evaluation manager uses the questionnaire to find potential problem areas in program or configuration management.

(4) **Assessment Criteria.** Qualitative. There are no quantitative evaluation criteria for this evaluation.

d. Risk Assessment Methodology for Software Supportability (RAMSS). RAMSS is a risk assessment method that provides software supportability information in terms of risks for those systems which are dependent on computer operations. Risk is defined as the probability of not accomplishing projected user software change requirements with the currently scheduled resources such as personnel, equipment, and facilities. The methodology employs a mathematical computer model and is organized so specific high-risk drivers can be identified for possible tradeoff analyses. The methodology draws on the results of the software maintainability, support resources, and support life cycle process evaluations. These stand-alone evaluation techniques provide information on particular deficiencies and are not necessarily presented in relation to one another. RAMSS ties all the software supportability evaluation factors together and identifies potential shortcomings. Whether contractor or military software support is planned, RAMSS examines evaluation results together with the estimated software change workload for a system once it transitions from development to its operational state. Findings are presented in terms of risk to the using and supporting commands.

(1) **Method.** The DSE or software evaluation manager uses the guidelines contained in draft AFOTTECP 800-2, volume 7, **Risk Assessment Methodology for Software Supportability**, to collect system workload information and the results of other software supportability evaluations. This information is used as input to the RAMSS model which calculates risk percentages and identifies particular areas of risk.

(2) **Data Requirements.** Input requirements for RAMSS are (a) the history of software support maintenance activities from the RAMSS data base, (b) the estimate of user/supporter software support require-

ments, and (b) the results of the software supportability evaluations: software maintainability, software support life cycle process, and software support resources.

(3) **Evaluation.** The DSE or software evaluation manager uses the RAMSS model to calculate the software support risk for a particular system and identify specific areas of risk to senior decision makers.

(4) **Assessment Criteria.** There are no quantitative evaluation criteria for this evaluation; however, a risk factor greater than .5 indicates an area of potential risk.

12-5. Other Software Evaluation Methods:

a. Spare Computing Capacity. Spare computer processing time and memory have both system effectiveness and suitability implications. Computer processing time and memory must meet current operational requirements plus provide sufficient computing capacity to allow for future software requirements. Spare processor time can be determined by examining idle processor time as a percentage of total available time. Spare memory can be determined by reviewing assembler/computer-generated memory usage tables and comparing them with the total memory available. Future processing and memory growth potential may also be included in this assessment.

b. Computer Security. This area of software evaluation is still being developed and is only stated as an OT&E objective if (1) required to support operations concerns, (2) the test support group feels a need to emphasize software security, or (3) stated as a critical issue. Typical requirements address data protection and processing integrity. A completed software security evaluation is useful for reporting OT&E concerns, but will not certify a system to process classified data. Details on conducting a computer security evaluation are documented in the draft AFOTTECP 800-2, volume 8, which is being developed.

c. Software Reliability. Software reliability (demonstrated and projected) is an integral part of system demonstrated and projected reliability computations. The Software Analysis Division has developed a method to project the effects of software on system reliability at maturity. This method uses a curve fitting technique on a software maturity curve for critical software failures to extrapolate to system maturity. The method also allows correction factors for imperfect debugging and software enhancements. The result is a software mean time between critical failure (MTBCF) at system

maturity. This result can then be combined with the hardware MTBCF to obtain a system MTBCF at maturity. More detailed information regarding software reliability is described in the Software Analysis Division's Software Reliability Handbook.

d. Adaptive Software Suitability Assessments. Adaptive software suitability assessments are structured approaches for addressing software concerns during early operational and operational assessments (EOA/OA) conducted as part of a system's operational test and evaluation. As such, these assessments will focus on (and become part of) the six areas of emphasis addressed during early operational and operational assessments: program schedule and resources, documentation, user requirements, programmatic problems inhibiting OT&E, special field activities, and programmatic voids and previous testing. This assessment methodology is still in the formative stages and will be documented in AFOTTECP 800-2, volume 9 (draft).

12-6. Software Evaluation Reporting. The AFOTTEC 800-2 series of evaluations are conducted throughout the software development life cycle. There are two types of reports published detailing the results of those evaluations: interim reports and final reports.

a. Interim Reports. The results of individual 800-2 series evaluations are condensed in interim reports published by the DSE or the software evaluation manager. While there is no specified format for interim reports, several things should be kept in mind by the author:

(1) Graphs and charts of evaluation results will condense a large volume of prose that otherwise becomes cumbersome to read.

(2) The interim report must have internal consistency, e.g., if maintainability characteristics have a well-above-threshold numeric score of 4.6, the author should not go into extensive detail explaining why the software is not maintainable. The 4.6 rating is self-evident.

(3) Present the good and bad. The author should highlight problems, but present a balanced report. Remember, the interim report will be used to get the program office to place management attention

on the problems the evaluators would like to see fixed to improve the quality of the software system. An extremely negative report will not achieve the goal and, in fact, may be ignored, and any communication with the SPO will probably be shut down. When writing an interim report, the author must remember that the target audience is the system program office.

(4) Do not come across like an IG. It will be counterproductive.

(5) Contact AFOTTEC/LG5 to review past interim reports for format. A DSE should work closely with the LG5 counterpart on drafting the interim report before having the OT&E test director sign and forward the report to AFOTTEC/TE.

(6) Ensure all emotionalism is removed. The report should describe evaluation results and conclusions/recommendations supported by those results. Unsubstantiated or inflammatory statements destroy the credibility of the report.

(7) Ensure AFOTTEC/LG5 gets a copy of the final version of the report. Also, after a system's final OT&E report is published, individual interim reports should be collected and attached to the OT&E Supplemental Data Document (SDD) which is compiled for the archives.

b. Final Reports. The software sections of a system's OT&E final report are the culmination of a program's OT&E. These sections should be the best software OT&E products written. There are specific rules for writing final reports, but not much detail for the software specific sections. AFOTTEC/LG5 has published a "Final Test Report Handbook, The LG5 Handbook to Writing Software Portions of OT&E Final Reports" (LG5 Handbook 55-43, 1 January 1991) which is updated on an annual basis to capture new AFOTTEC reporting policy. Copies of the handbook are available from LG5. DSEs and report authors should not wait until the handbook is needed for a final report, but should get it as soon as possible as the guidance in the handbook provides an excellent framework for what the total focus of the software OT&E should be. Furthermore, anyone having suggestions on how to improve the final report fidelity should not hesitate to contact the Division Chief, Software Analysis Division (AFOTTEC/LG5).

Chapter 13

INTEGRATED DIAGNOSTICS

13-1. Introduction. This chapter presents background material on developing an understanding of integrated diagnostics concerns as applicable to the maturation and testing of Air Force systems.

a. Purpose:

(1) This is a guide for HQ AFOTTEC logistics staff members who evaluate integrated diagnostics as part of the operational suitability evaluation. An integrated diagnostics concept impacts many aspects of a system's development and utilization. It encourages the incorporation of adequate diagnostics capability early on in the conceptual and design phases of a system and broadens the depth and scope of the system's diagnostics as it matures through development and deployment. Proper implementation of integrated diagnostics ensures the best possible mix of diagnostic resources will be available to support the fielded system.

(2) A system's intended integrated diagnostics design drives much of its logistics support planning. Maintenance training, spares, support equipment, and technical data are planned to support the system's requirements for a comprehensive and effective integrated diagnostics system. When the diagnostics do not perform as expected, one or more of these logistics factors must be altered to provide the necessary system support. Significant changes in a system's diagnostics capability or resources are often unprogrammed and expensive. Delays in implementation impact cost and schedule, and until workarounds are established, system support suffers. Therefore, an operational evaluation of the overall integrated diagnostics is needed as early in the acquisition cycle as possible. This chapter explains some of the aspects of an integrated diagnostic evaluation and focuses on the critical role the automated diagnostics plays in support of the overall diagnostic requirements.

b. Scope of the Evaluation Method. Integrated diagnostics usually serve two functions: to monitor and report system status for an operator and to be used as a maintenance tool for repair.

(1) For the first function, the diagnostics are used to monitor system performance and provide any necessary indication of critical system/subsystem performance degradation. This indication provides the operator with the necessary information to decide whether to rely on that system/subsystem's perform-

ance or to revert to an available backup system. If no backup system is available, the operator must decide if the mission's operation should be aborted.

(2) For the second function, the diagnostics are used to confirm the initial indication a malfunction exists and then to indicate what type of corrective action is needed to restore the system.

(3) The focus on the evaluation method described in this chapter is on the second function, evaluating how well a system's diagnostics perform as an O-level maintenance tool. However, this method does provide some information on how well the diagnostics support the system operators and the system's mission reliability. This evaluation method applies to all systems from aircraft and missiles to ground-based electronic systems. The methods should be tailored to the specific system being evaluated.

c. Definitions. An understanding of certain terms is needed for evaluating integrated diagnostics. Following are definitions of essential terms. Other definitions related to diagnostics can be found in MIL-STD 1309C, Definitions of Terms for Test, Measurement, and Diagnostic Equipment.

(1) **Diagnostics.** The process employed to identify and isolate system malfunctions.

(a) **Automated Diagnostics (AD).** Any combination of software, firmware, or hardware fault detection techniques that, once initiated, require no further operator intervention. These built-in test (BIT) or self-test techniques may be periodic (continuous) or have some finite number of predetermined repetitions.

(b) **Semiautomated Diagnostics.** A set of software/firmware/hardware diagnostic techniques that require some level of operator or maintenance technician interaction. These diagnostics are designed to aid in identifying and isolating system malfunctions and may include built-in test equipment (BITE) such as displays (digital/analog waveforms or alphanumeric), procedural switch actions, or reading of various meters or indicators.

(c) **Manual Diagnostics.** A diagnostic process that is based on the system operators or maintenance technicians using observations of system performance, knowledge of system design and operation based on their training and experience, logical analysis,

external test equipment, and technical data.

(d) Integrated Diagnostics. The process of efficiently using the most effective combination of a system's automated, semiautomated, and manual diagnostics resources in order to identify and unambiguously isolate the cause of malfunctions.

(2) Anomaly. Any other than normal occurrence such as false alarms, system malfunctions, or identified system failures.

(3) Malfunction. Any system performance degradation that may require corrective maintenance.

(4) Failure. A physical condition that causes a device, component, or element to fail to perform in a required manner.

(5) Fault Indication. Any device which can be used to convey to the operators an indication of system degradation. This may include audible alarms, visual displays gauge readings, etc.

(6) Fault Isolation (FI). The process of isolating the cause of a fault.

(7) False Alarm (FA). An indication of a system malfunction without sufficient confirmation of the system's degradation to result in a requirement for any corrective maintenance action. (This definition differs from the definition in MIL-STD 1309C.) A key point to note is a false alarm does not generate a maintenance action.

(8) Cannot Duplicate (CND). An operationally observed/recorded system malfunction that maintenance personnel were unable to duplicate.

(9) Retest Okay (RTOK). A unit that has been identified as malfunctioning at one maintenance level, but the specific malfunction cannot be duplicated at a higher maintenance level.

(10) Vertical Testability. The inherent diagnostic capability at each level of maintenance to ensure any associated malfunction, identified to a specific unit under test (UUT) at one level of maintenance, can also be replicated at any of the other maintenance levels designated for that unit.

nance levels designated for that unit.

(11) Built-In Test/Fault-Isolation Test (BIT/FIT) Effectiveness. BIT/FIT effectiveness is the capability of system automated diagnostics to properly detect critical system malfunctions, minimize the diagnostic time for fault-isolation and repair verification, minimize the diagnostic time for line-replaceable units (LRU) that are erroneously identified as malfunctioning, and minimize maintenance man-hours. BIT/FIT effectiveness is not evaluated independently but rather is evaluated as to its influence on quantitative maintainability. BIT/FIT effectiveness is a subjective assessment of the utility of BIT/FIT as a maintenance tool and its impact on maintenance resource requirements. A single-thread data system, ensuring an audit trail, should be employed to track malfunctions, subsequent repair actions, and post-repair performance of the alleged faulty system. The data system should possess the capability to track equipment by serial number, part number, job control number, work unit code, and aircraft tail number. Additional information captured should include total repair time from start of the maintenance event to its completion, associated corrective action, method of fault identification, and subsequent fault isolation from on-equipment discovery through repair of the replaced component.

d. Repair Process:

(1) Planning an operational evaluation of integrated diagnostics requires an understanding of the role of diagnostics in the repair process. The process begins when a malfunction is identified during system operation and progresses through the five phases shown in figure 13-1.

(a) In the setup phase of the repair process, access panels are opened, required equipment is hooked up, switches are set, power is applied, and other necessary preparatory tasks performed. This work is predominantly manual.

	<u>SET-UP</u>	<u>DIAGNOSIS</u>	<u>PHASES</u> <u>FAULT-CORRECTION</u>	<u>CHECKOUTS</u>	<u>CLOSEOUT</u>
<u>METHOD</u>	MANUAL	MANUAL SEMI-AUTOMATED AUTOMATED	MANUAL SEMI-AUTOMATED	MANUAL AUTOMATED	MANUAL

————— Mean Repair Time —————

Figure 13-1. Repair Process

(b) The diagnosis or troubleshooting phase is usually performed in two steps. The fault confirmation step attempts to confirm the problem reported by the equipment operator does exist. Once a fault is confirmed, the FI step attempts to locate the cause of fault. These steps can be performed manually, semiautomatically, automatically, or by some combination of the three methods.

(c) In the fault-correction phase, proper operation of the system is restored by adjustment, removing and replacing broken components, etc. These actions are also predominantly manual.

(d) The checkouts phase confirms the fault has been corrected, usually by repeating the fault confirmation step of the diagnosis phase. The work in this phase also may be performed manually, semiautomatically, automatically, or by some combination of the three methods.

(e) The closeout phase reverses the work done in the setup phase, readying the system for operation. The work here again is predominantly manual.

(2) The personnel involved in each of the five phases of the repair process may require the maintenance support elements of technical data, support equipment, tools, facilities, and personnel training. In addition, spare parts are often required for the diagnosis and fault phases.

(3) The repair process takes time. Since the objective of the repair process is to restore a system to operation, how quickly the process can be performed is the primary measure of the efficiency of the process. Repair time depends not only on the type of malfunction but also on the maintainability designed into the system and the effectiveness of the support elements. Each of these factors can vary for each phase of the repair process. For example, an aircraft fuel leak can be detected and isolated in minutes, but because of the design of the fuel cells and the need for special tools and facilities, fault correction may take many hours. On the other hand, diagnosing the cause of an avionics malfunction may take hours and require not only built-in AD but also external test equipment. However, because of easy accessibility and modular component design, fault correction may take only minutes. Both malfunctions may take the same length of time to repair, but the time required for each repair phase will vary considerably.

e. Diagnostics Design:

(1) Evaluation planning requires an understanding of general diagnostics design. Typically, the system for which the diagnos-

tics are designed is divided into those areas which are addressable by AD and those areas which are not.

(2) Designers of AD do not attempt to have their diagnostics detect and isolate all faults. Faults that can be readily detected visually, such as broken knobs and cracked indicators, are excluded from their AD design. Although analog systems are less reliable than digital systems, they have less AD incorporated within their system because of cost constraints. Digital systems, while having higher reliability, are often extensively integrated with AD because of lower diagnostics development costs. Circuits used to check wiring and interface problems are costly and tend to somewhat lower total system reliability. Diagnostics that could detect multiple failure scenarios are realizable but are often considered cost prohibitive. Two practical constraints other than costs that often limit the application of AD are the space and weight factors. These factors present a more significant restriction to airborne AD systems than ground based systems.

(3) The fault detection (FD) specifications are relevant in the operational environment where the concern is knowing when and what functions of a system are not performing properly. However, the FI specifications must be primarily concerned with unambiguously isolating the system faults as quickly as possible. Automated FI's contribution to expeditions repair depends on how well the automated diagnostics are integrated into an interactive and flexible maintenance concept.

(4) Several factors can degrade the expected effectiveness of AD. The sensitivity of FD can be so great that momentary transients are displayed or recorded as faults when, in fact, the system continues to perform satisfactorily. This condition results in a high number of FAs or CND maintenance actions. Conversely, FD can be so insensitive that true system faults such as intermittent which should be detected are not. Either situation may result in loss of user confidence in the AD.

(5) For some systems, particularly aircraft, operating and maintenance environments differ. FD, designed to operate while the aircraft is flying, may indicate faults caused by G-forces, vibration, temperature extremes, radio-frequency interference (RFI), or electromagnetic interference (EMI). Since these in-flight conditions are not duplicated on the ground, fault indications often terminate in CND maintenance actions.

(6) In some systems, the automated diagnostics are not designed to fully isolate

to the one malfunctioning unit. Instead, the diagnostics isolate to an "ambiguity group," e.g., the malfunction is in one of three units. This condition usually requires manual FI to locate the malfunctioning unit within the ambiguity group. Depending on the size of the ambiguity group, this requirement to manually isolate the fault may significantly extend repair times, reducing the effectiveness of the AD.

(7) Because AD design is often based on a predicted failure distribution, the distribution actually experienced in the operational environment may be significantly different, and this may degrade the effectiveness of the AD. As an example, despite the low theoretical probability of their occurrence, multiple faults and wiring failures may constitute up to 20 percent of the operational failures within a system. If the AD is not designed to detect and isolate these types of conditions, the troubleshooting may be ineffective and the required manual diagnostics may lengthen repair times.

(8) Test have shown that ADs often fail to live up to their expected capabilities. As a result, supplemental diagnostics techniques are usually required despite high automated FD and FI requirements.

13-2. Planning the Evaluation:

a. Early Involvement:

(1) Planning for a diagnostics evaluation must begin early in the acquisition cycle. Details of a system's diagnostics design and the diagnostics' development schedules (including software updates) are needed for test planning. However, this information usually is not readily available as early as it is needed, since diagnostics design is often deferred until other aspects of design are more firm. During IOT&E, diagnostics is usually incomplete. Despite this situation, most of the necessary planning information can be obtained by reviewing program documents from attending program meetings. These activities give a logistics evaluator the opportunity to help focus on specific methods and plans which can be used in the diagnostics evaluation. In addition, early involvement in the diagnostics design and development process can inject lessons learned from other programs. The early critique of the system from its use during IOT&E can result in effective diagnostics being delivered earlier than they otherwise would have been. The result is a more supportable system.

(2) In terms of an operational evaluation of diagnostics, the most significant information in program documents (MNS, ORD) is the user's required system restoration time.

This requirement could be expressed as mean downtime (MDT), mean repair time (MRT), maximum time to repair, or turnaround time. The diagnostics must contribute to achieving this required restoration time. If the MNS or ORD omits such measures, AFOTECP should recommend they be added.

(3) The MNS or ORD should contain an integrated diagnostics approach instead of automated FD and FI percentages. These documents should recognize the need for 100-percent integrated diagnostics capability based on the most cost-effective mix of manual, semiautomated, and automated diagnostics. This requirement simply expresses the operational need to confirm and isolate all faults which prevent or degrade system operation. If this requirement is not already in the documents, include it in your recommended changes.

(4) A second category of documents relates to the request for proposal (RFP) and acquisition contract. The system specification, the statement of work (SOW), the contract data requirements list (CDRL), and the model contract contain information needed for planning an integrated diagnostics evaluation. At times, however, these documents omit vital information, or the information is not properly stated. Your objective in reviewing the documents should be to obtain necessary test planning information and to make specific recommendations to correct errors as early as possible. Drafts of these documents are often received for review individually over a period of time. Requirements stated in one of these documents should track through all the documents, since each document should eventually become part of the RFP/contract.

(a) The specification describes how the system is to work and includes required reliability and maintainability characteristics as well as the overall maintenance concept. The specification should describe the desired diagnostic techniques for system operation and maintenance. It should state whether AD will continuously monitor system performance or be initiated by the operator and whether these diagnostic results will be recorded for later maintenance analysis. It should define the allowable FA and CND parameters and the size of the FI ambiguity group. The specification should describe the relationship of AD to the various subsystems as well as to external support equipment. It should include the required system restoration time from the MNS or ORD and describe how the diagnostics will support meeting this requirement. The specification should indicate the areas of the design that

will be addressable by AD and what areas will be solely dependent on manual diagnostics. The specification may include automated FD and FI percentages, but these figures can be misleading. They should show a direct relationship to the achievement of 100-percent critical FD and 100-percent FI through a combination of automated, semi-automated, and manual diagnostics.

(b) The SOW describes the actions the contractor must take to produce an item that will meet the specification. The SOW should include a section on integrated diagnostics. This section should require the contractor to prepare an integrated diagnostics plan, to perform design and analysis, and to conduct tests to ensure a 100-percent integrated diagnostics capability is provided by the most effective mix of BIT, support equipment, technical data, and training to achieve stated operational requirements. The SOW should also require the contractor to ensure vertical testability among all levels of necessary contractor support during OT&E. When the contractor must maintain the system during test, the SOW should require the contractor to perform maintenance using the same diagnostic techniques that will be provided for Air Force use in the operational environment. The SOW should also identify whether the contractor or blue-suiters will document maintenance actions and specify a maintenance data collection system acceptable to both the DT&E and OT&E commands.

(c) The CDRL identifies all the documents the government intends to buy from the contractor. Each document is described on a DD Form 1423, CDRL. CDRL is a package of these forms and is created from an earlier action called the "data call" where interested government agencies can identify the contractor data they need. Actions described in the SOW should have corresponding documents listed in the CDRL. Any CDRL document must have a corresponding SOW action. Contractor documents relevant to planning an integrated diagnostics evaluation are listed in figure 13-2. This list should be checked for currency before requesting any documents. During the data call and CDRL review, ensure these documents are listed when appropriate and your office is on distribution for them.

(d) The model contract is a draft of the contract intended for the winner of the source selection. It should contain the key requirements from the specification, SOW, and CDRL. Any changes you recommend in these documents should also be added to the

model contract.

(5) For source selecting, contractors are able to propose exceptions to the model contract. If you participate in the source selection, study the contractors' proposed exceptions carefully. Regardless of what is stated in other sections of the proposal, what the contractors really intend to deliver is expressed in their proposed model contract. For example, the SOW requirement to ensure 100-percent integrated diagnostics capability may be proposed for deletion in a contractor's model contract despite other parts of the proposal supporting it.

(6) After source selection, carefully review the actual contract to ensure the diagnostics provisions from the specification, SOW, CDRL, and model contract survived contract negotiation. What is in the contract has a significant influence in test planning. If it is not clearly identified within the contract, do not expect to see it in the system.

(7) Much of the additional information needed for evaluation planning is obtainable at various system program meetings. In addition to providing planning information, these meetings also allow the logistics evaluator the opportunity to influence integrated diagnostics development.

(8) Integrated logistics support and other logistics-oriented meetings can provide such information as delivery schedules for technical data and support equipment. These meetings are usually attended by key system program managers and their staffs who are responsible for the design of the automated diagnostics. These logistics managers usually assume in their logistics planning the diagnostics will be effective. Any shortfalls in the expected AD design will impact their logistics planning. The logistics managers can provide the necessary program redirection to head off anticipated shortfalls only if time and money are available. For this reason, early information on potential shortfalls is essential. Through early involvement in the program, the AFOTTEC logistics evaluator is often able to provide this information.

(9) Other needed information can be obtained from design reviews and similar engineering meetings. These meetings are attended by engineers responsible for the design and development of a system's diagnostics capability. These people are able to provide detailed information on diagnostics design, but are less aware of the impact their design will have on the maintenance support elements being planned. Again, the AFOTTEC logistics evaluator is often in a

<u>Data Item Description (DID) Number</u>	<u>Title</u>	<u>Description</u>
US-92-AFLD and UL-780-ESD	Integrated Diagnostics Plan	Outlines contractor's program for achieving 100% fault detection and isolation. These two DIDs were created for the HH-60D and North Warning System (NWS) line radar replacement programs respecifications but could be applied to other programs.
DI-T-3734A/M	Test Requirements Document (TRD)	Describes line-replaceable unit (LRU) test conditions.
DI-E-3120A	Computer Program Product Specification	Describes software organization. Includes flowcharts and listings.
DI-A-6102A/M	Support Equipment Plan	Describes support equipment. Useful for determining what tests require support equipment to supplement automated diagnostics.
DI-L-6138	Integrated Support Plan	Comprehensive plan for integrated logistics support. May contain the integrated diagnostics plan.
DI-R-3533	Reliability/Maintainability Program Plan	Maintainability portion useful for determining contractor development planning for diagnostics.
DI-T-3701	System Test Plan	Provides scope of contractor's test program. May include demonstration of diagnostics.
DI-A-3009	Program Milestones	Provides current schedule for delivery of other data items, including those supporting integrated diagnostics.
DI-A-6101A/M	Contractor Engineering and Technical Services Plan	Spells out the level of contractor (vs Air Force) involvement in maintenance during test. "Will Air Force technicians be using integrated diagnostics to maintain the test system or will contractor people do it with workarounds?"
DI-E-3101	System Specification	Describes the total system in detail. Should cover what the contractor plans to provide in the way of integrated diagnostics. (This is not the same system specification from the RFP.)
DI-H-6131M	Training and Training Equipment Plan	Shows how the contractor plans to handle the training end of the integrated diagnostics.

Figure 13-2. Contractor Data Needed for Diagnostics Evaluation Planning

Data Item	Description	<u>(DID) Number</u>	<u>Title</u>	<u>Description</u>
DI-S-3606	System/Design Trade Study Reports			Can be used to document how tradeoffs will be performed among automated, semiautomated, and manual diagnostics techniques.

Figure 13-2 (continued)

position to point out this impact.

(10) Other program meetings are oriented to the system's software. These meetings can provide diagnostics software design information and delivery schedules. This information is essential for logistics evaluation planning since software is usually developed and delivered incrementally. For this reason, full diagnostics capability is often not achieved until late in the acquisition schedule. The operational evaluation should be planned to look at each successive software update. OT&E results can provide the necessary feedback to correct software errors in subsequent updates.

(11) In some programs, where system support depends heavily on AD, a diagnostics development working group may be formed. Meetings of these groups provide vital information on all aspects of the diagnostics. The involvement of the logistics evaluator in such groups is essential.

(12) The meetings mentioned above do not automatically provide the information needed for planning a diagnostics evaluation. The information usually comes only by asking the right questions. Answers to questions like the following will provide information on what we need to be aware of and will guide the scope of the evaluation:

(a) What are the differences in processing logic and fault display between diagnostics for system operators and diagnostics for maintenance technicians?

(b) Does the AD have more than one mode to accommodate different operational maintenance conditions? Examples: Procedures may differ from main operating base (MOB) to forward operating bases, diagnostics may be designed to work around portions of the system that may receive battle damage, or diagnostics can be selective under certain operational conditions to expedite faster turnarounds using larger ambiguity groups, combined with a liberal LRU replacement policy (wholesale ambiguity group

replacement).

(c) What techniques are provided to automatically record malfunctions?

(d) What equipment is available/required to interrogate recorded diagnostics data for subsequent troubleshooting?

(e) What techniques are available during maintenance to duplicate various malfunctions that can result from a combination of environmental conditions that result directly from operationally induced stresses? (This is particularly significant for aircraft systems.)

(f) What techniques are used to minimize operator errors?

(g) What techniques are used to minimize FAs?

(h) What techniques are used to minimize CNDs and RTOKs?

(i) Can the automated diagnostics detect any gradual system degradation or intermittent failures, and can it separate these types of significant, but hard to detect, faults from fault indications caused by transients that often result in FA?

(j) What techniques are available to the operator to confirm, reset, or update a system's operational status?

(k) What is the LRU ambiguity level of FI?

(l) Do FI procedures take into account wiring and interface failures?

(m) To what failure level have the diagnostics been designed (internal to chip, input/output (I/O) of chips, internal to card, I/O of cards, within the LRU, I/O of LRU, at a higher level)?

(n) To what sensitivity level have the diagnostics been designed (less than worst-case tolerances, worst-case tolerances, beyond worst-case tolerances, for specified time intervals, etc.)?

(o) Has the system been designed to worst-case combinations of power or voltage variations, coupled with environmentally induced degradations (i.e., temperature, vibra-

tion, humanity, etc.)?

(p) Have the same worst-case design techniques used on the system hardware been used for diagnostics hardware design?

(q) Has adequate time been provided to validate system operation after the DT&E hardware, firmware, and software changes have been incorporated within the system prior to entering IOT&E?

(r) What is the schedule for software updates that contain changes to the diagnostics?

(s) What diagnostics improvements will result from these updates?

(t) What provisions have been made for vertical testability?

(u) What techniques are used to detect and isolate multiple faults?

(v) What provisions have been made to ensure the availability, reliability, and maintainability of diagnostic support elements such as test equipment (TE) and technical orders (TO)?

b. Scoping the Evaluation:

(1) Once an understanding of the diagnostic parameters has been obtained, the next step is to scope the diagnostics evaluation to prepare for writing the test plan. An operational evaluation of integrated diagnostics involves much effort, detailed data collection, and dedicated test team resources. To provide a good evaluation and not waste resources requires careful scoping.

(2) Several factors drive the scope of an evaluation. Consider the following:

(a) Significance of the diagnostics to the maintenance concept. System support, which relies heavily on BIT integration throughout the major subsystems, warrants an in-depth diagnostics evaluation. On the other hand, an evaluation of a simple go/no-go test routine for a noncritical subsystem should be incorporated in an overall maintainability evaluation.

(b) Maturity of the diagnostics during operational testing. Diagnostics development usually lags the rest of system design. Early operational testing must contend with immature diagnostics. Diagnostics software, TOs, and support equipment are delivered incrementally, often at the end of IOT&E. Do not plan an extensive evaluation of diagnostics if the full diagnostics capability is not scheduled to be delivered until after the test period.

(c) Availability of the appropriate personnel for the test team. In addition to equipment operators and maintenance technicians who use the diagnostics and generate data, the scope of an operational evaluation may be severely limited if the following types

of personnel are not available.

1. Data managers to organize and control the data collection process.

2. Additional maintenance technicians dedicated to guiding data collection and evaluating the data.

(d) Intended length of the test period and the extent to which the diagnostics will be used during this period. Money and schedules limit the time available for operational evaluation. A thorough operational evaluation of a complex system may require a minimum of 4 to 6 months of daily use of the diagnostics. Even if this time is available, a highly reliable system or a system operated infrequently will limit the use of diagnostics and, consequently, the evaluation.

(e) Availability of both a user-approved maintenance concept and an adequate maintenance data collection system during test. When a system is maintained during OT&E by a contractor who provides the maintenance data, as sometimes happens during combined development and operational testing, the chances are slim the maintenance data will be detailed enough to support a diagnostics evaluation. In this case, you should plan on extra test team members to monitor the contractor's use of diagnostics and to document the troubleshooting times and other maintenance data in an Air Force data collection system. Video recording equipment and other means of diagnostics data collection should be considered.

(f) Whether or not the automated diagnostics has a built-in recorder that will allow analysis of diagnostics data generated during system operation, coupled with a printing and interpretation capability, such a recorder can capture data that could be especially useful in determining FD capability and the extent and nature of FAs and CNDs. However, qualified people and time are needed to evaluate these data.

These factors need to be weighed in determining the overall scope of a diagnostics evaluation. Weighing these factors is "coarse tuning" the evaluation. "Fine tuning" comes during detailed planning.

c. **Detailed Planning:** Detailed planning includes defining the objectives and selecting the measures to be incorporated in the test plan. For an evaluation of diagnostics, plan to incorporate simple, operationally relevant objectives and measures that can be derived from operator and maintenance data.

(1) The first step in detailed planning should be obvious—thinking clearly about and writing down the objective. Depending on the scope of the evaluation, diagnostics

may be a separate objective or embedded with MOEs under other objectives such as mission reliability or maintainability. In either case, the objective or MOEs are mutually dependent on several other objectives in the test plan. In addition to maintainability and mission reliability, some diagnostics MOEs may fall under logistics supportability such as RTOKs, technical data, support equipment, maintenance training, and software. Each of these objectives and support elements is interdependent and is required to effectively evaluate a system's integrated diagnostics capability. However, an operational test plan, containing multiple objectives relating to diagnostics, can result in fragmenting the evaluation rather than guiding the test team through an integrated analysis of the various diagnostics elements. The best way to state the objective in the test plan is "evaluate the system's integrated diagnostics." The section on "Method" under this objective should detail what will be evaluated (hardware, software, displays, etc.) and describe relationships with other objectives in the test plan (system availability, maintainability, and mission reliability in addition to technical data, support equipment, training, and software).

(2) Once you have structured the integrated diagnostics objective within the overall test plan, you are ready for the second step, selecting the measures that will help guide the evaluation. There are many measures available for evaluating diagnostics.

(a) The primary approach to selecting parameters for an operational evaluation is to use diagnostics measures (and related criteria) from the ORD.

(b) The parameters should be based on operational uses of any integrated diagnostics assets by either system operators or maintenance technicians. For the operators, the diagnostics are supposed to detect critical failures and convey that information to them in a clear and timely manner. The operator wants to be confident that all critical failures are detected and any highly visible indicated failure represents an unacceptable level of system degradation. The maintenance technician, on the other hand, wants to be able to use integrated diagnostics to help confirm a reported failure and to accurately, efficiently, and effectively isolate the cause of the failure.

(3) Five measures are needed to tell how well a system's integrated diagnostics perform these operational functions. Each measure is made up of several data elements characteristics, and some measures are computed in more than one way. These

measures are:

(a) Percentage of critical faults indicated (CFI) to the operators in a clear and timely manner, which is computed from operational and maintenance data by the equation:

$$\% \text{ of CFI} = \frac{\text{\# of CFI to operator in a timely manner that resulted in a CMA request}}{\text{\# of CFI to operator in a timely manner that resulted in a CMA request} + \text{\# of critical faults identified after-the-fact}} \times 100$$

1. CFIs to the operator in a timely fashion are any malfunctions that unacceptably degrade the system's capability to support its mission requirements. Any degradation or significant loss of system capability must be clearly identified to the operator in time for the information to be properly used. Examples of these types of losses are:

a. A countermeasure system that is not adequately jamming hostile sensors, but clearly identifies the malfunction to the operator in a timely manner.

b. A malfunction within a missile system that prohibits its launch or the missile's capability to properly acquire/lock on to a target, but clearly notifies the operator of the failure within seconds.

c. An inertial navigation system that clearly indicates to the operators as soon as it has degraded below the accuracy required to ensure reasonable mission success.

2. Critical faults identified after the fact fall into two general groups:

a. Faults that were identified to the operators at some time during the mission but had not been immediately identified at the time of their occurrence. The late notification did not permit the operator adequate time to take the necessary corrective measures and resulted in compromising mission capability. If a timely notification of the system malfunction can be reported to the operators, it would permit the operators to reduce unnecessary manpower/equipment risk by making an early-on decision to abort the mission, revise the mission, or use some operationally available backup system/subsystem/unit. The system/subsystem/unit could then have provided the essential capability to support the operational requirement and continue the mission. Examples:

(1) A missile that cannot be prop-

erly launched or, if the missile can be properly launched, will not have the capability to acquire/track or disable its assigned target; but unfortunately, the operator was not informed of the system malfunction until the actual attempt to launch the missile.

(2) An INS that has degraded below acceptable mission requirements, but the loss of effectiveness was not promptly conveyed to the operator. Because the operator was not given a timely fault indication, no attempt is made to utilize any effective alternate backup system such as a doppler radar.

b. Faults discovered after the mission has been completed. These faults often are not identified until mission performance data are reassessed.

(1) A missile that has a defective guidance flight but was not identified to the operator prior to launch. The fault is identified after launch by tracking the missile's performance.

(2) Engine foreign object damage (FOD) during flight, but only discovered during postflight inspection.

(b) Unconfirmed faults (FA and CND) by an operational unit (UF/OU) that are computed from operational and maintenance data by the equation:

$$UF/OU = \frac{\# \text{ of FA} + \# \text{ of CND}}{\# \text{ of operational units (sorties, operational hours, etc.)}}$$

1. Unconfirmed faults are the sum of FAs and CNDs reported to system operators.

2. The operational unit of operation can be sorties, flying hours, mission operational hours, or hours of operation with power applied.

3. If appropriate, separate parameters such as FA/OU and CND/OU may be used.

(c) Mean time to troubleshoot (MTTT), which is computed from maintenance data by the equation:

$$MTTT = \frac{\text{total of all O-level troubleshooting times}}{\# \text{ of O-level troubleshooting actions}}$$

This general equation should be broken down into its three significant components as follows:

1. First Component:

a. MTTT when only manual troubleshooting techniques are effective.

$$\text{mean time for manual fault isolation (MFI)} = \frac{\text{total O-level time spent in isolating faults in which only manual diagnostics were effective}}{\# \text{ of O-level FIs in which only manual diagnostics were effective}}$$

b. Percentage of O-level manual FIs (percentage MFI).

$$\% \text{ MFI} = \frac{\# \text{ of O-level FIs in which only manual diagnostics were effective}}{\# \text{ of O-level troubleshooting actions}} \times 100$$

2. Second Component:

a. MTTT when BIT contributed to the FI process.

$$\text{MTTT when BIT aids FI} = \frac{\text{total O-level time spent in isolating faults in which BIT contributed to the fault isolation process}}{\# \text{ of O-level FIs in which BIT contributed to the FI process}}$$

b. Percentage of BIT contributed FIs (percentage BCFI).

$$\% \text{ BCFI} = \frac{\# \text{ of O-level FIs in which BIT contributed to the isolation}}{\# \text{ of O-level troubleshooting actions}} \times 100$$

3. Third Component:

a. Mean time devoted to investigating CNDs.

$$\text{mean time to investigate CND} = \frac{\text{total O-level time spent investigating malfunctions that terminate in a CND}}{\# \text{ of O-level FIs that terminate in a CND}}$$

b. Percentage of faults that terminate in a CND (percentage of CND).

$$\% \text{ of CND} = \frac{\# \text{ of O-level FIs that terminate in a CND}}{\# \text{ of O-level troubleshooting actions}} \times 100$$

(1) The O-level troubleshooting time starts after setting up equipment and turning on the power and is terminated prior to the final repair/replacement action. If units (LRU/SRU) are replaced in order to reduce the ambiguity group, the replacement is included within the troubleshooting time. The troubleshooting time will terminate at

the initiation of the final repair or unit replacement action that unambiguously isolates the problem.

(2) Only the O-level CMA that involved troubleshooting is included within the CMAs assessed within the third measure of (MTTT).

(d) Contribution of integrated diagnostics support elements in troubleshooting (i.e., TOs and TE), which is assessed from qualitative maintenance data and recorded on forms such as the AFTO Form 349 or AFSC Form 258. This measure most fully incorporates the integrated diagnostics concept by assessing the key supporting factors needed to ensure an adequate integrated diagnostics approach has been implemented in support of a system's mission requirement. The principal integrated diagnostics supporting factors are the TOs, TE, and training. These factors must be assessed from two aspects: First, from a standpoint of supporting the total mission's diagnostics requirements; and second, from the aspect of efficiently using available personal and material resources and the effectiveness in using these resources to support the implementation of an integrated diagnostics concept within a system.

(e) Percentage of LRU/SRU that retest okay (RTOK) at a higher maintenance level, which is computed from maintenance data by the equation:

$$\% \text{ of RTOK} = \frac{\begin{array}{l} \# \text{ of LRU/SRU} \\ \text{that RTOK at a} \\ \text{higher maintenance level} \end{array}}{\begin{array}{l} \# \text{ of LRUs tested at higher} \\ \text{maintenance level} \end{array}} \times 100$$

1. The LRU/SRUs RTOK at the higher maintenance level if they do not demonstrate the same functional anomaly they demonstrated at the lower maintenance level.

2. If the initial LRU/SRU anomaly that had been detected and identified at a lower maintenance level can be reverified as malfunctioning in the same manner at a higher maintenance level, then that LRU/SRU did not RTOK.

Note: Data needed to assess this measure are often limited until the later stages of operational testing.

13-3. Conducting the Evaluation and Reporting the Results:

a. Introduction:

(1) Conducting the evaluation is the most difficult phase of the test cycle. The dynamics of operational testing make it extremely difficult to control the data collection required for a diagnostics evaluation. Be

aware of these difficulties.

(2) The types of difficulties vary with the type of operational test. In a combined DT&E/IOT&E, diagnostics is usually immature. This condition is often compounded if the system is being maintained by a contractor. During a dedicated IOT&E, diagnostics is still often immature resulting in such factors as the operator's seeing frequent FAs and reluctance of maintenance to use the designated diagnostics for maintenance troubleshooting. Diagnostics may be more mature during a follow-on operational test and evaluation (FOT&E). However, during this period, the using command is usually operating and maintaining the system in order to achieve an initial operational capability. The emphasis is on rapid maintenance to keep the system working.

(3) Other factors further compound the difficulty of conducting diagnostics evaluations. Most acquisition programs have software and hardware updates that are scheduled to occur throughout the operational test period. Often these updates are intended to improve diagnostics as well as performance. If the originally delivered diagnostics do not work well, there is a tendency to defer diagnostics use until these improvements are incorporated. To make matters worse, these update schedules frequently slip and the improvements are not incorporated until late in the operational test period. Moreover, in the rush to improve performance, updates that were also expected to improve diagnostics sometimes do not. Diagnostics improvements are then scheduled in the next software or hardware update. These situations often result in limited diagnostics data, in an unprogrammed extension to the operational test period to acquire the required data, or an inability to properly evaluate the system's diagnostics capability.

(4) While conducting the evaluation is the most difficult phase of the test cycle, reporting the results of the evaluation is the more critical. The report needs to convey clearly how the diagnostics performed and what needs to be done to improve performance. The intent of the report is to sufficiently inform decision makers so they can make an appropriate production decision/direct funds and action to fix identified diagnostics problems. If the report does not do this, the entire evaluation may have been a waste of time.

(5) This final section combines the two subjects of conducting and reporting the evaluation to emphasize the close relationship they have to each other. Decisions as to what to report and how to structure the

report should be made continuously throughout the evaluation. Do not wait until all the data are in before beginning the report.

b. Gathering and Analyzing the Data:

(1) The first step in conducting the evaluation is gathering data from the operators and maintenance technicians who use the diagnostics during the operational test (see AFOTEC/LG operating instruction 66-1). Analyzing the data should be a continuing process that begins as soon as data collection starts.

(2) Figure 13-3 recaps the six measures presented earlier and lists the factors needed to compute each measure.

(3) The data gathering process should be structured and controlled to provide the factors needed to compute the diagnostics measures. Unfortunately, the standard maintenance data collection systems available to operational test teams will not provide (in their present form) all of these factors. These data collection systems are the maintenance data collection (MDC) system and the system effectiveness data system (SEDS). At present, these two data systems should be supplemented by manual data collection or by a computerized data base management system created by or for test teams with access to and control over their own data base.

(4) Regardless of the data system used, data must be generated from each operating period for each troubleshooting maintenance action. The data must be structured to answer questions such as:

(a) What percentage of critical faults were identified to the operator? There are only two ways this can happen: manually or automatically.

(b) How were faults indicated to the

operator? By what means are we asking here?

(c) How many FAs did the operators observe?

(d) How many CNDs did maintenance report?

(e) How long did it take to troubleshoot malfunctions?

(f) Did BIT contribute to the fault isolation process? Qualitative LRU fault isolation is not even addressed in this document even though we often have user requirements. LRU fault isolated when used in conjunction with percent of LRU failures is a viable method of evaluating a systems diagnostic capability.

(g) How many I-level or D-level RTOKs were reported?

(5) When tabulated, answers to these questions will generate the factors for the diagnostics measures. Answers to the first three questions on critical failures and FAs must come from operator debriefing records or operator logs. Determination of critical failures will be based on the definition established from a system's specific mission requirements. Answers to the fourth question must come from both operator and maintenance logs. Some systems are designed to record and play back anomalies detected during a mission, and whenever possible, these recordings should be used to analyze causes of FAs, CNDs, and system failures.

(6) Answers to the last four questions must come from maintenance technicians and be documented in the test team's maintenance data collection system.

(7) Gathering and analyzing diagnostics data have some peculiarities not found in routine maintenance data collection and

Measures

Description

% of CFI	Percentage of critical faults to the operators in a clear and timely manner
UF/OU	Unconfirmed faults per operational unit (sorties, hours, etc.)
MTT	Mean time to troubleshoot (troubleshooting action)
Qualitative Maintainability	Qualitatively assess integrated diagnostics support elements
% of RTOK	Percentage of LRU/SRU that RTOK

Figure 13-3. Integrated Diagnostics Measures and Factors

analysis. One peculiarity occurs when the diagnostics cannot easily and unambiguously isolate a fault within an ambiguity group. The technicians may be driven by operational time constraints and resort to the removal of any suspect units. If troubleshooting these units is performed at a higher maintenance facility with some level of automated checkouts equipment, the O-level automated diagnostics (BIT) cannot be credited with aiding this fault isolation segment. If the system remains down until the malfunction is identified and corrected, it should be charged against O-level MTT, MRT, and MDT.

(8) Data relating to troubleshooting times should be reviewed carefully and frequently—preferably daily. The daily screenings should check for illogical entries. For example, a maintenance data record reporting an automated troubleshooting action taking 15 hours is probably wrong. Purely automated troubleshooting would seldom take long, so either the time entry is wrong or troubleshooting was really performed by a combination of automated and manual techniques. In either case, the apparent data discrepancy must be resolved quickly while the technicians who performed the work still remember what actually happened.

(9) Periodically, throughout the evaluation, the MTTT measure should be checked for accuracy by comparing the MTTT to MRT or MDT times coming out of an overall maintainability evaluation. The MTTT value should be less than the MRT or MDT value.

(10) There is a continuing requirement to reassess the maintainability diagnostics throughout the evaluation. Early in the test period, technicians may spend a great deal of time troubleshooting before concluding they cannot duplicate the reported malfunction. As testing progresses, and the technicians' experience increases, they may spend much less time troubleshooting before they sign off their maintenance as a "CND." This tendency would result in a decreasing MTTT figure as the test progresses. This decrease can be attributed to the frustration involved in what often results in an unproductive investigation.

(11) Near the end of the evaluation, the MTTT figures should be analyzed from the viewpoint of what will be said in the evaluation report. If the overall MTTT figure is satisfactory, there may not be much need to present more detailed data comparing mean times for manual, BIT aided, or CND troubleshooting. However, if this situation occurs, carefully consider the conditions under which troubleshooting time data were gath-

ered. Contractor engineers or skilled test team members using nonstandard work-around techniques could result in a good overall MTTT figure, but these results would not be realistic in a true operational environment.

(12) More typically, if the diagnostics do not work well, the results will be higher than the desired overall MTTT figure. This overall figure should be amplified in the final report by comparing the other MTTT figures to the overall figure. This comparison will show the reductions in troubleshooting time which could be expected if BIT could be used more effectively during all troubleshooting actions.

(13) A further peculiarity in diagnostics data analysis centers around determining when a unit retests OK. When O-level testing indicates a faulty unit, it usually is retested at the I- or D-level to confirm and locate the fault. If testing fails at this higher level to confirm the fault, the unit is classified as an RTOK.

(14) As mentioned earlier, there is a tendency to defer diagnostics data gathering until the latest software or hardware update. However, if the diagnostics are at all usable, data gathering and analysis should begin as early as possible. The data should be segmented for each configuration change that affects diagnostics (block 1, block 2, etc.). Trend analysis of the measures for each configuration will show if diagnostics performance is improving as expected after each update. This trend analysis can also identify needed diagnostics improvements.

(15) Diagnostics data should be analyzed for trends in FAs, CNDs, and RTOKs. Trend analyses of these measures may help identify problems, causes, and solutions.

(16) Diagnostics data should also be analyzed to identify the few units that might be driving any adverse trends—the "bad actors." Simply removing these units from service may significantly improve diagnostics FA, CND, and RTOK performance.

(17) A point made earlier but worth repeating is the data analyses should begin when data collection starts and should continue throughout the evaluation. Continual data analysis hopefully can catch most of the errors in the data collection process in time to prevent reporting wrong conclusions drawn from erroneous data.

c. Reporting the Results:

(1) Before reporting the results of the diagnostics evaluation, consider the results in context with the evaluations in other effectiveness and suitability areas that are dependent on the diagnostics. Ensure what

you intend to say concerning diagnostics is consistent with what is being said in other portions of the report. For example, if the maintainability evaluation concludes that system maintainability is good, your evaluation should have concluded that system diagnostics effectively supported the system's fault isolation requirements or the inconsistency should be explained in detail. The various portions of the evaluation that are dependent on the diagnostics should be logically consistent with the diagnostics evaluation and vice versa. If not, the test team must detail the reasons for the inconsistency in a logical and understandable manner.

(2) Once you have the diagnostics evaluation results in their proper perspective, you are ready to begin writing. The clearest way to present diagnostics evaluation results is to first describe how the diagnostics are intended to work for operators and maintenance technicians. Next, report how they actually worked by describing diagnostics deficiencies determined during the evaluation. Then discuss the operational consequences of these deficiencies. This approach will have to be adapted to the format prescribed for the report. On the other hand, the prescribed format should not prevent you from presenting the diagnostics results in

this manner.

(3) Do not rely on the quantitative measures by themselves to tell the story. Use the measures to quantify the story that should be presented in as nontechnical a language as possible with a minimum of abbreviations.

(4) Tables can help present the data as long as the significance of the data is explained in the text. As examples, figure 13-4 illustrates how some of the quantitative data can be presented in the report, while figure 13-5 illustrates a way of presenting troubleshooting data.

(5) If evaluation results indicate the integrated diagnostics perform poorly, and the diagnostics are a significant factor in the system's supportability, consider writing an additional, more detailed report on the diagnostics. The overall operational test and evaluation report will provide the broad perspective and impact of poorly performing diagnostics to high-level decision makers. The more detailed report should provide specific recommendations to a program for fixing diagnostics deficiencies. To be successful, both types of reports should clearly identify the expected benefits of improving diagnostics so decision makers can determine whether to spend money on diagnostics or for other needed system improvements.

SYSTEM DIAGNOSTICS RESULTS

<u>Measures</u>	<u>Results</u>	<u>Criteria</u>
% of critical faults identified to operator	XX.X%	YY.Y%
% of critical faults identified to operator by BIT (Operational Subset)	XXX%	YY.Y%
Unconfirmed faults per operator unit	XX/X	YY/Y
FA per operational unit (CND per operational unit optional subsets)	XX/X	YY/Y
MTT (O-level troubleshooting)	XX.X hr	Y.YY hr
% of RTOK	XX.X%	YY.Y%

Figure 13-4. Example of Table for Presenting Diagnostics Results

SYSTEM TROUBLESHOOTING RESULTS

<u>Troubleshooting Techniques</u>	<u>Mean Time to Troubleshoot (Hrs)</u>	<u>% of Diagnostics Actions</u>
Only Manual Effective	X.XX	YY.Y
BIT Contributed	X.XX	YY.Y
CND	X.XX	YY.Y

Figure 13-5. Example of Table for Presenting Troubleshooting Results



JAMES A. WILLIAMS, SMSgt, USAF
Director of Information Management

PETER D. ROBINSON
Major General, USAF
Commander

NUCLEAR HARDNESS MAINTENANCE/HARDNESS SURVEILLANCE (HM/HS)

A1-1. Introduction. The Air Force expends many dollars of our scarce acquisition resources to ensure selected systems will be usable in transattack or postattack nuclear environments. These selected systems have a nuclear survivability requirement. Survivability is defined as the "capability of a system to withstand a man-made hostile environment and be able to accomplish its mission. Survivability may be achieved by avoidance, hardness, proliferation, reconstitution, or any combination of the above (AFR 80-38, Management of the Air Force Survivability Program)."

a. Avoidance, proliferation, and reconstitution are tactics or planning considerations. We can plan to locate our assets where exposure to nuclear environments is expected to be minimal or nonexistent (avoidance). We can plan to buy many systems and scatter them over large areas expecting a percentage of them to survive and operate (proliferation). We can also make arrangements for spares, manpower, support equipment, etc., to be readily available to repair expected nuclear environment-induced damage to our systems (reconstitution).

b. Hardness is a design consideration which must be built into a system to ensure its ability to function in expected nuclear environments. Ideally, hardness is an initial design consideration and is planned for and built into a system from the outset. Hardness has been retrofitted into some of our older systems whose initial designs did not consider nuclear threats or new threats evolved that were not anticipated by the initial designs. The need and methods to maintain and periodically verify a system's built-in nuclear hardness are the objective of an operational suitability assessment and will be the focus of this chapter.

A1-2. Explanation of Terms:

a. **Hardness Maintenance.** Actions taken to ensure that as-produced system hardness is not degraded over the life cycle of the system because of maintenance procedures, modifications, or other factors (AFR 80-38). It is the procedures applied to ensure that system operations, logistics support, maintenance actions, or natural causes, e.g., corrosion, do not degrade the system's designed and fielded hardness below acceptable levels.

b. **Hardness Surveillance.** Measures taken to evaluate and assess the hardness of a fielded system. It is an ongoing process

throughout a system life cycle (AFR 80-38). Hardness surveillance includes specialized tests and inspections performed to ensure design hardness is being adequately maintained in fielded systems.

c. **HM/HS Concept.** Developed in the early stages of an acquisition program, this document details the management approach for a weapons system's life cycle HM/HS program. It addresses the hardness design approach, user's HM/HS needs and constraints, and provides an overview of acquisition and operational responsibilities for HM/HS requirements. It should address each level of maintenance and highlight new skills that will be needed, HM/HS-peculiar support equipment that must be developed or procured, and related areas such as training, technical data, spares, etc. Specialized system, subsystem, LRU, and component-level hardness testing that is planned or required should also be addressed. The HM/HS concept development is normally an AFSC (implementing command) responsibility.

d. **HM/HS Plan.** A comprehensive HM/HS life cycle plan which evolves from the HM/HS concept. The HM/HS plan details the HM/HS program for the production-approved and fielded system and logistics support infrastructure.

e. **Hardness Assurance Design Documentation (HADD).** A set of technical documents which provide detailed information on hardness design, assumptions, safety margins, and specifications. Developed by the contractor, the HADD is maintained and used primarily by the supporting command to assess the hardness impacts of modifications, parts substitutions, or related actions on fielded systems.

f. **Hardness Critical Item (HCI).** A hardware item at any indenture level which is critical to the nuclear hardness of the system, subsystem, or LRU in which it is employed and could be degraded by improper design, manufacture, assembly, modification, installation, removal, or repair. HCIs typically include items such as EMP gasketing, zener diodes, surge arrestors, and other specialized pieceparts selected for their nuclear hardness properties.

g. **Nuclear Effects.** The physics of a nuclear detonation and the subsequent effects on the surrounding environment are complex, and therefore, a detailed explanation of nuclear effects of interest will not be attempted here. Numerous papers and texts are available to those who are interested in

the details of nuclear phenomenology, and one of the most authoritative, "The Effects of Nuclear Weapons," Glasstone, Samuel and Dolan, Philip J., 1977, is available in LG3 for review. The effects of primary interest from a nuclear HM/HS standpoint are blast, thermal, transient radiation effects on electronics (TREE), crew radiation dose, and electromagnetic pulse (EMP).

(1) **Blast.** Blast or overpressure is one of the commonly recognized nuclear effects. It is a strong pressure front caused by the rapid expansion of hot gases from a nuclear detonation interacting with surrounding ambient air, water, or earth media. Blast waves in air are characterized by high velocity winds initially followed by high negative pressures or suction. Blast wave velocities are directly related to the distance of the observer from the detonation, height of burst, and the transmission media; but initial velocities may be several times the speed of sound. Blast effects can cause damages ranging from total destruction to minor distortions, cracking, or bending of structures.

(2) **Thermal.** Thermal or thermal radiation is the heat energy released from a nuclear fireball in the form of ultraviolet, visible, and infrared radiation. The incendiary effects of a thermal pulse are the most widely recognized. Temperatures experienced can be from several millions of degrees Fahrenheit in the immediate proximity of a detonation to significantly lesser amounts based on the distance from the explosion and the absorption or scattering characteristics of the transmission medium. Thermal effects on systems can range from total incineration to structural weakening or thermal disruption of semiconductor device operation.

(3) **TREE.** Nuclear radiations consist of alpha and beta particles, gamma rays, and neutrons. Alpha and beta particles are not of great importance because of their relatively short ranges, but gamma rays and neutrons can pose significant threats to weapons systems and living organisms. Their effects on electronics is referred to as TREE and is primarily observed as disruption or loss of critical systems or subsystems.

(4) **Crew Dose.** This term describes the prompt nuclear radiation effect on humans and is expressed as the total amount of radiation absorbed over a period of time or as an exposure rate, i.e., the amount of radiation absorbed per unit time (usually per hour). It is a measure of prompt nuclear radiation effects as opposed to secondary effects such as extended exposure to fallout. Crew exposure can result in minor discomfort

to illness, loss of motor or coherent mental functions, or death.

(5) **EMP.** Electromagnetic pulse effects on weapon systems are responsible for the majority of hardening design features and HM/HS requirements. EMP is basically a high amplitude, fast rise time, broadband wave comprised of intense electric and magnetic fields that radiate outward from a nuclear burst. The phenomenon is caused by the collision of gamma rays and from the nuclear burst with molecules in the atmosphere which cause the release of high energy electrons (Compton electrons). The resultant wave is basically similar to a radio wave except in a couple of major respects: The EMP wave is significantly more intense than a radio wave (EMP intensities can be on the order of 50,000 volts per meter), and the EMP wave is an extremely short pulse wherein virtually all its energy is experienced in a few nanoseconds (10^{-9} seconds). Actual EMP intensity is primarily a function of height of burst, weapon yield, and distance. Because EMP can be wide-ranging, especially in the case of high-altitude or ex-atmospheric bursts, Air Force systems on the ground, in the air, or in space may be affected by EMP without experiencing the other effects described above. EMP effects on Air Force systems can range from temporary upset of electronic systems to burnout of electronic devices and subsequent loss of critical systems or subsystems.

A1-3. Directives and Scope:

a. Directives:

(1) DODD 4245.4, Acquisition of Nuclear Survivable Systems, 25 July 1988.

(2) AFR 80-38, Management of the Air Force Survivability Program.

b. **Scope.** Nuclear hardness and a life cycle program to ensure hardness is a requirement for all systems, major and non-major, including modifications, that have a nuclear survivability requirement. DODD 4245.4 specifically states that for systems with a nuclear survivability requirement, "The acquisition program shall include development of a life cycle hardness program."

A1-4. OT&E Responsibilities. Operational test agencies (OTA) have a responsibility to adequately assess a system life cycle hardness program as they would any other Air Force and user required capability. The Deputy Director of Defense for Operational Test and Evaluation (DOT&E) is specifically tasked in DODD 4245.4 to "...confirm adequate assessment during OT&E including combined DT&E/OT&E." In addition, DODD

4245.4 requires the OT&E outline in test and evaluation master plans (TEMP) to "...describe how tests shall validate both operational effectiveness and suitability including hardness maintenance and surveillance." OTAs must ensure user life cycle hardness program requirements are clearly stated in requirements documents such as the mission need statement (MNS), operational requirements document (ORD), etc. Requirements must be stated comprehensively enough to allow the implementing command to develop a program to meet the user's needs and to support an adequate OT&E assessment. After completing the OT&E assessment of the system life cycle hardness program, the OTA must include their findings in the final OT&E report for the system.

A1-5. HM/HS Assessment Methodology.

An HM/HS assessment includes system familiarization and documentation review, involvement in DT&E survivability test planning, final OT&E test plan and detailed test procedure formulation, test execution, and reporting.

a. Systems Familiarization and Documentation Review. This is one of the cornerstone tasks of HM/HS assessment planning. It is normally undertaken by OTA headquarters personnel at the earliest stages of a system acquisition. The fundamental questions that must be comprehensively investigated and answered include:

(1) Does the system have a nuclear survivability requirement? If so, is the requirement clearly stated in the MNS and PMD? Are the 80 series AFRs (specifically AFR 80-38) specified for this acquisition (see the Authority and Deviation section of the PMD)?

(2) Is hardness design one of the methods that will be used to ensure survivability? If so, is a life cycle hardness program specified as a user and system requirement? Is the specified program consistent with the using command's maintenance concept?

(3) Is a system HM/HS concept and plan specified on contract? Are subcontractors also required to support concept/plan writing and revisions based on the equipment they provide and testing they conduct (this requirement is sometimes overlooked and almost always results in the need for a contract modification/renegotiation as subcontractor participation and data are essential for a complete and usable document)? Is the OTA on distribution for the concept/plan deliverables?

(4) Is the HADD on contract? Are subcontractors required to input and revise

HADD information for their subsystems? OTAs generally should not request to be on distribution for HADD deliverables as they are usually voluminous, of limited use in the planning and conduct of an operational test, and specific volumes or information can usually be readily accessed through the SPO if required.

(5) Does the HM/HS concept adequately scope the life cycle hardness program for all levels of maintenance?

(a) Does it address user and supporting command requirements/constraints, and is it consistent with the system hardness design (if the design uses shielded cables, are provisions made for inspecting/testing the cable shield; if terminal protection devices such as zener diodes, surge suppressors, etc., are used, how will they be tested; etc.)?

(b) What will be done at each level of maintenance and who will do it? Is specialized test equipment envisioned? Is it available off-the-shelf or must it be developed? Who is responsible for procuring this equipment and related technical data, training, spares, etc.?

(c) What specialized HM/HS training is envisioned? Does it include general hardness awareness training on a recurring basis as well as any required technical training? Is hardness awareness training to be provided for operators and management personnel as well as maintainers? (Hardness design features and their maintenance are generally transparent to normal peacetime operations, i.e., peacetime operations will normally be unaffected by degradation/malfunction of hardness critical items. Only through initial and recurring awareness training of the importance of these items and their maintenance can the survivability of the system in a nuclear environment be ensured.)

(d) Have reprovisioning and substitution controls for hardness critical items been discussed? Are controls planned to ensure proposed substitutions, configuration changes, or modifications are reviewed and approved by a survivability engineer before implementation?

(e) Have provisions been made to collect and analyze HM/HS data from the field. Will work unit codes (TO -06 series) be allocated so field HM/HS data can be uniquely coded and extracted from the maintenance data system for analysis? Who will be responsible for this analysis? Will it provide the using and supporting command maintenance planners the information they need? Will a computer model be used for individual system or fleet probability of hardness predic-

tions based on field HM/HS and other data? Who will develop and maintain the model? Will the model output provide strategic planners the information they need for war-planning?

(6) Does the HM/HS concept and/or plan contain state hardness-related testing that will be accomplished?

(a) Will testing be done to provide detailed visual inspection acceptance/rejection criteria for HCIs (this testing is generally critical to provide maintenance personnel with viable criteria for visual inspection of hardness elements such as gasketing, shielded cable overbraid, etc.)? Technical orders should definitively state exactly what constitutes damage to these elements by providing pictorial representations of acceptable and unacceptable damage and/or by providing measurable criteria, e.g., any tear in gasket may not exceed .5 inch in length, no more than two adjacent fingers in fingerstock gaskets may be missing, no more than five fingers in the total length of fingerstock may be missing, etc.

(b) Will testing be done to establish a threat-relatable HM/HS baseline (hardness design criteria and hardening features are developed based on nuclear threat-level values, i.e., threat levels that would be anticipated in an actual nuclear environment)? HM/HS testing is done at levels typically much less than anticipated threat levels. Because the low-level HM/HS test measurements are not directly relatable to threat-level measurements, establishment of a threat-relatable baseline is generally desirable. This is typically done in conjunction with threat-level testing at simulators such as Trestle, Horizontally Polarized Dipole, or Vertically Polarized Dipole. Selected test points on the test article are measured initially on the threat simulator and then on the low-level HM/HS simulator—frequently a system-level continuous wave (CW) illuminator. The values from each set of measurements can then be compared and a baseline for future HM/HS measurements can be established).

(c) Will testing be done to verify the utility of proposed commercial off-the-shelf or developmental HM/HS support equipment?

b. Involvement in DT&E Test Planning. Nuclear effects testing is normally the responsibility of development testers. OTAs provide support to these test efforts to ensure test articles are configured and operated in an operationally realistic manner and to ensure that OT&E data needs relating to the nuclear effects testing are met. This requires close coordination with the DT&E test plan-

ners, typically in a planning forum such as the test planning working group (TPWG) or a survivability/vulnerability working group (SVWG). OTAs may require independent OT&E contractor support to assist them in this area of HM/HS assessment because of the highly technical nature of the planning and actual testing which frequently requires an understanding of the phenomenology, simulation/instrumentation constraints and limitations, and test data analyses. This contract support is often obtained through a joint effort with the Operations Analysis (OA) Directorate who also frequently rely on contract support for investigating effectiveness issues relating to the nuclear effects testing. LG3 has a memorandum of agreement on file which delineates the responsibilities of LG and OA personnel in obtaining and managing contract support for survivability test planning. One of the deliverables often required of the OT&E contractor, primarily on major weapon systems, is a nuclear assessment plan (NAP). The NAP is a structured approach to OT&E nuclear assessment planning that is generally conducted in two or more phases. AFOTTECP/OA Technical Paper 13.0, April 1988, should be addressed in the DT&E nuclear effects test planning phase. HM/HS assessment factors to be addressed include:

(1) Is a nuclear assessment plan to be developed? If so, the logistics evaluation manager must work closely with his OA counterpart to ensure all HM/HS and effectiveness issues are addressed by the NAP and the NAP is structured to support relevant critical operational issues and OT&E test objectives.

(2) Will an independent contractor be used by the OTA to assist in DT&E test planning reviews, assessments, and recommendations? If so, the logistics evaluation manager must provide his OA counterpart with HM/HS assessment requirements to be included in contract subtask statements. Contractor assistance is normally valuable in the following areas:

(a) Comparison of user HM/HS requirements and maintenance concepts, HM/HS concepts, and related information with the overall DT&E nuclear effects test planning program to identify shortfalls, inconsistencies, or omissions.

(b) Comparison of planned DT&E test points with mission critical or suspected nuclear effects-sensitive systems, subsystems, or LRUs. A limited number of test points can be measured in any given test effort. Care must, therefore, be exercised to ensure the most critical test points are given priority

in the test planning effort.

(c) Review of DT&E test planning to ensure planning includes visual inspection acceptance/rejection criteria testing and establishment of quantifiable, threat-relatable HM/HS baseline (see paragraphs 5a(6)(a) and (b) above). If the system to be tested is already in OT&E, valuable information relating to which HCIs are failing frequently because of inherent or induced causes can be obtained by interviewing test team personnel. These HCIs should be given special attention by the DT&E testers as they will probably be high failure items in the fielded system and will require frequent inspections.

(d) Thorough review and analysis of planned HM/HS baseline testing. The baseline testing must provide a quantifiable "measuring stick" that can be used on fielded systems. Numbers, types, and locations of baseline test points should be reviewed to ensure they are reasonable based on test equipment to be used in the field, technicians that will be performing the tests, time that will be allowed for testing, expected reliability of the area being tested (are we measuring the areas where we expect problems), etc. In addition, the technical soundness of the approach used to relate the low-level measurements to threat level and the establishment of comprehensive low-level pass-fail criteria should be assessed.

(3) Is the planned DT&E testing as operationally realistic as possible? Are support equipment, GFE, pylon-mounted weapons, deployed antennas, etc., that will be used or connected to the system in an operational environment planned for use in the DT&E tests? Some items that may be connected in a normal operating mode, e.g., a power cart on an alert aircraft, can pose a significant energy penetration into an otherwise hardened system. In addition, some items of support equipment that may be critical to the operation of the system under test may not have initially been developed as hardened items. To emulate the operational environment as much as possible and to test the potential "worst-case" scenarios, careful attention must be given to realistic operational configurations. Regular participation in TPWGs and/or SVWGs is necessary to ensure proposed test configurations are realistically planned and required assets are programmed for well in advance.

c. **OT&E Plan and DMAP.** HM/HS is normally addressed as a stand-alone objective, an MOE of a nuclear survivability objective (effectiveness issues constitute other MOEs), or it is addressed under logistic support objectives. An example of an HM/HS

dedicated test objective is "assess the adequacy of the System X nuclear hardness program to ensure system hardness throughout the System X life cycle." Regardless of how the test plan is structured, the basic areas of assessment are usually the same. Major areas of interest and questions that should be considered in test plan and DMAP formulation include:

(1) **Technical Data.** Are HCIs and HCPs properly marked in the TOs (usually in accordance with MIL-STD 100C/Engineering Drawing Practices)? Are the proper tools and support equipment cited in the TOs for HCPs. Are definitive pass-fail criteria provided for visual inspections and for manual, semiautomated, or automated surveillance testing? Have provisions been made for unique coding of hardness-related maintenance actions and failure data?

(2) **Training.** Have provisions been made for initial and recurring hardness awareness training for operations, maintenance, management, and support (supply, procurement, etc.) personnel? Is this training consistent with system hardness design and the life cycle hardness management program developed for the system? Will the training program be fully developed and in place to support fielding of the system?

(3) **Supply Support.** Have procedures been developed to ensure HCIs are not substituted for at base or depot level without the approval of the cognizant survivability engineering office? Has a HADD or similar document been developed to document HCI specifications, margins, and assumptions to support survivability engineering in parts selection?

(4) **Support Equipment (SE).** Is required HM/HS-peculiar SE available? If not, has responsibility for procurement of HM/HS-peculiar SE been assigned and agreed to? Has the SE been tested and verified as adequate? Can it be used in the environments and by the personnel specified in the maintenance concept? Have necessary technical data been developed for the SE? Have definitive pass-fail criteria been provided? Does the SE meet portability or transportability requirements, as applicable?

(5) **Other Areas:**

(a) **HM/HS Data Management.** Has a using or supporting command office been assigned responsibility to extract, analyze, and report on field HM/HS data? Have provisions been made to implement revisions, modifications, or other changes to inspection intervals or types of inspections based on HM/HS data analyses?

(b) **Hardness Configuration Control.**

Have provisions been made to ensure any proposed modifications or changes to the system are reviewed and approved by the cognizant survivability engineering office before implementation?

(c) **Hardness Computer Model.** Have provisions been made for development of a system model, if applicable, to formulate individual asset or fleet hardness estimates based on field HM/HS data? Will the model be available to support system IOC? Are model outputs adequate and appropriate for anticipated users of the data?

d. Test Execution and Reporting. HM/HS test execution and reporting are normally joint headquarters and test team efforts. Early HM/HS program and requirements documentation reviews and early DT&E test planning involvement are usually done by headquarters personnel. As the test team is assigned and becomes familiar with HM/HS objectives, they assume more of the assessment responsibilities and are normally responsible for final assessment in all the HM/HS areas. Final reporting is accomplished as structured in the test plan, either addressed as results to a specific objective or as results to specified MOEs.

A1-6. HM/HS Office of Primary Responsibility and HM/HS References. The Logistics Directorate OPR for HM/HS is LG3. References maintained in LG3 that are useful for OT&E HM/HS assessment planning and nuclear effects familiarization include the following:

a. The Effects of Nuclear Weapons, Glasstone and Dolan, 1977.

b. B-1B EMP Nuclear Assessment Plan, Booz-Allen & Hamilton, Document No. 09006-141/102-02/0026, 30 September 1986.

c. B-1B Hardness Maintenance/Hardness Surveillance Plan, Rockwell International, NA-86-1587, 20 November 1986.

d. Nuclear Hardness and Survivability OT&E Methodologies for Air Force Tactical Systems, The BDM Corporation, BDM/ABQ-86-0889-TR, October 1986.

e. Videotape, "Hardness Maintenance: It Depends On You," OL-ALC.

f. Videotape, "Nuclear Survivability: Introduction to Hardness Maintenance," OC-ALC.

g. Videotape, "Assessing the Nuclear Survivability of Aircraft," OC-ALC.

h. LG Training Course, "Nuclear HM/HS Assessment," LG3.

DORMANT RELIABILITY

A2-1. Introduction:

a. **Purpose.** This chapter summarizes the current state of the art in identifying the effects of dormancy as it relates to operational reliability. It does not provide an exhaustive treatment of dormant reliability. The chapter provides a framework in which to develop an approach to evaluate the effects of dormancy on a specific system.

b. Background:

(1) The reliability of military systems after long periods of dormancy has been a major concern throughout military history. A system taken out of storage is expected to accomplish its mission within some acceptable degree of performance degradation. In early military history, spoilage of items such as food and gunpowder was a major concern. A few years ago, when aircraft availability exceeded flying requirements, care was taken to periodically move parked aircraft to mitigate the effects of nonuse (e.g., flat tires, fluid drain, etc.). As military systems continued to become more sophisticated, complex, and expensive, and as their response time has become shorter, the need for higher reliability has increased. Inherent in that need is a requirement for higher dormant reliability.

(2) AFOTTEC is involved in the operational test and evaluation (OT&E) of a number of weapon systems—principally munitions—that spend extensive periods of time in storage. Historically, these systems have exhibited relatively high reliability, but on newer systems complexity is increasing, longer service lives are required, and periodic maintenance and checkouts are being reduced or eliminated. Therefore, concern about the effects of dormancy on a system's operational reliability is growing, and development of an approach for assessing dormant reliability as part of the test and evaluation process is becoming increasingly important.

c. **Structure.** The next paragraph presents a compilation of pertinent concerns about dormancy and establishes the need for considering its effects. Paragraph A3-3 then discusses the characteristics of the dormancy problem. Paragraph A2-4 addresses some considerations relevant to the assessment of dormant reliability, and paragraph A2-5 summarizes documented methodologies for estimating dormant reliability. Specific assessment tools and techniques are discussed in paragraph A2-6, an approach to dormant reliability follows in paragraph A2-7, and paragraph A2-8 concludes with a sum-

mary of lessons learned from specific programs.

A2-2. The Need for Considering Dormancy Effects:

a. **Dormancy and Weapon Systems.** The sophistication and complexity of modern weapons coupled with the rapid response time required to effectively counter the expected threat preclude extensive checkout and repair prior to employment. In particular, dormancy in munition systems is a concern because these systems spend the majority of their life in a nonoperating environment (e.g., containerized/noncontainerized storage, alert, etc.). Also, many subassemblies of munitions do not operate during captive carry. The wooden round maintenance concept under which munitions are accepted and deployed to operational units as "all-up rounds" with minimal field-level checkout and maintenance clearly increases the ratio of nonoperating time. In a typical munition system, even with periodic checkout, nonoperating time could be as much as two million times longer than operating time. While such a large ratio of nonoperating to operating time may not be the case for other types of weapons, the fact that most weapons do spend considerable time in a dormant state makes dormancy a major factor to consider when attempting to estimate or project a mature system's operational reliability.

b. Policy, Guidance, and Direction:

(1) Only limited guidance exists for the design and conduct of testing for dormant reliability. Reliability testing is addressed in a general sense under operational suitability in OMB Circular A-109, Major System Acquisitions, the DOD 5000 series directives, and AFR 800-18. MIL-STD 1388, Logistics Support Analysis, mentions dormant reliability by stating that the logistics support analysis for reliability factors provides data for "...effects of storage, shelf life..." The data input to the LSA comes from MIL-STD 785, Reliability Program for Systems and Equipment Development and Production, reliability programs. MIL-STD 785 discusses administrative requirements and general guidance for reliability testing but provides no specific guidance for dormant reliability assessment.

(2) Rome Air Development Center (RADC) studies related to nonoperating failures have consistently concluded that government documents establishing and supporting reliability requirements should be upgraded to

include provisions for nonoperating mode reliability requirements and predictions. Degradation effects in various dormancy states (e.g., operationally ready (OR) storage, handling and transportation, launcher carriage, alert, captive carry) must be considered in addition to those of the normally energized (active) state.

A2-3. Characterization of the Dormancy Problem:

a. Dormancy:

(1) Dormancy is defined as those states in which a system is not operating or is being maintained in OR storage—including all on-equipment maintenance and functional checks or built-in test (BIT) necessary to maintain the desired status. Dormancy is defined at the subsystem level when those subsystems are installed on the complete weapon system. This concept is logical in that some subsystems may be totally inactive (e.g., missile rocket motors) while other subsystems (e.g., missile guidance units) may be operating during various phases of the system's life cycle prior to completing a mission.

(2) For tactical munitions, the weapon may rotate through various operational postures—OR storage to alert, OR storage, captive carry, etc. Strategic systems may spend long periods of time in an alert status with guidance systems operating and the remainder of the subsystems totally inactive.

(3) The OR storage mode is predominant in that it is in this state where reliability degradation caused by dormancy is most apparent. The ability of a system to withstand OR storage may be influenced by relatively short periods of operating time or the stress inherent in other states, such as transportation. Conversely, the ultimate operational reliability is influenced by the ability to withstand long periods of dormancy.

b. Dormancy Effects:

(1) Failures experienced during dormancy have basically the same effect as other failures on logistics. Required spares provisioning, manpower and inspection interval requirements, and their associated costs throughout a system's life cycle are affected by dormant failures and must be correctly estimated if the system is to be adequately supported. The effects of dormancy on operations are more closely related to the capability of the system to function effectively. Not all failures are critical. Those which are critical certainly affect operations; those which are not may not impact operations but they directly affect logistics.

(2) The task for the analyst is to deter-

mine those failures which directly affect operational capability. For example, suppose a certain seal tends to dry out and crack after prolonged periods of dormancy. A failure mode and effects analysis (FMEA) would conclude that hydraulic fluid leaks because the seal cracks. The logistics analyst would conclude that more spare missiles will be required to support the wooden round maintenance concept because the hydraulic actuation system leaks during storage. The operations analyst would conclude that the missile will probably miss the target because the hydraulics system fails to drive the control surfaces. The effects of dormancy must be addressed at a level which permits estimation of their impact on operational effectiveness and suitability.

c. Inherent Limitations:

(1) There are several limitations inherent in the nature of the dormancy problem. First, when a system fails during dormancy, it is extremely difficult to know when the failure occurs. Second, if checks of the system are performed during dormancy, those checks may induce a failure. Third, it is generally difficult to tell what caused a failure—age, transportation stresses, manufacturing defects, and induced maintenance failures could be some of the candidates.

(2) Measuring the effects of dormancy may require calendar time in excess of that scheduled for a typical operating system in test and evaluation. As such, dedicated dormancy programs during OT&E are usually not planned. Rather, AFOTTEC piggybacks off AFSC/AFLC-initiated programs (e.g., warranty programs, shelf-like extension programs, surveillance programs, etc.).

d. Interactive and Long-Term Nature of the Process:

(1) An alternative for actual measurement of dormancy is to pursue the development of early estimating projection methodologies (even rules of thumb) and test methodologies that can be improved over time. In addition, AFOTTEC involvement and coordination with all system development participants are essential so early program data, tests, and surveillance programs can be structured in a mutually supportive way. Detailed knowledge of other methods, even though they might not be applicable to OT&E, and knowledge of weapon systems in general are both necessary to improve the process. Also, AFLC may conduct special test and evaluation programs on fielded systems, the final reports of which are available from the system program manager at the managing ALC.

A2-4. Dormant Reliability Assessment Considerations:

a. Dormant Reliability:

(1) Paragraph A2-3 discussed the characteristics and effects of dormancy on weapon systems. Now, the focus is on measurement of those effects and assessment of their impact on system reliability.

(2) Reliability is the probability that an item will remain failure free under specified conditions over a specified period of time or be in a failure-free state after a specified period of time. In considering dormant reliability, the same reliability definition applies except that "over time" covers several possible states which exhibit potentially different failure characteristics. Thus, a full treatment of dormant reliability must consider all possible states—*inherent dormant reliability, OR storage reliability, and the reliability associated with other periods of time when the system is not operating.*

(3) Therefore, dormant reliability is defined as the probability that an item will remain failure free for a specified period of time in a nonoperating mode under stated environmental conditions. When the system is removed from the dormant stage, it is expected to perform within specifications.

b. Acquisition Process Considerations:

(1) The AFOTTEC planning process will usually begin near Milestone 0 and continue beyond Milestone II in the acquisitions process. Early in the conceptual phase, reliability specifications will be formulated by the developing command from the using command's operational requirements. Depending on the input to the dormant reliability assessment approach, some initial insight into dormant reliability requirements could be obtained during the conceptual phase. Data for any assessment will come primarily from the system program office (SPO) and the developing contractors and will generally be limited to specifications and preliminary designs.

(2) As the program progresses into the validation phase, data should be available from failure modes analyses, design reviews, initial reliability evaluation tests, and failure analyses. Again, the SPO and contractor will be the sources of the information. From the operational tester's viewpoint, the usability of the data will depend on understanding how it was obtained. For tactical missiles, specialized data systems at WR-ALC and OO-ALC are also a source of historical information.

(3) During IOT&E, operational failure data will be available, and some dormant failure data may be available from surveil-

lance program, assuming that such programs were initiated early. Attention must be paid to the nature and characteristics of data gathered during various phases of OT&E to ensure that any differences—based, for example, on preproduction versus production versions of the system—are understood and accounted for.

c. System-Specific Considerations.

System-specific considerations are directly related to the system hardware, its intended operating environment, the operational and maintenance concepts, and the system's projected life cycle profile. A thorough understanding of each of these areas is required to effectively assess the effects of dormancy and project dormant reliability for the given system.

d. Test and Evaluation Considerations. Some considerations include inherent limitations in the OT&E process, the role of sampling and its relationship to OT&E, methodologies for projecting mature system dormant reliability based on OT&E results, and capabilities for verifying or establishing the validity of early reliability predictions. A brief discussion of each of these follows:

(1) **Inherent Test Limitations.** Major limitations during OT&E are usually resource related. That is, when the amount of time and assets devoted to test are limited, a thorough and adequate assessment of dormant reliability is extremely difficult to accomplish. Potential dormant reliability assessment problems can be reduced through early involvement and careful planning.

(2) Sampling:

(a) Because it is not feasible to obtain failure rate measurements on entire populations of weapon systems, the techniques of reliability assessment rest on statistical concepts. Such techniques permit the extrapolation of results obtained from a sample to the total population and possibly to other similar populations. Selection of an appropriate sample of systems for testing depends on the hypothesis to be addressed and the potential risks associated with accepting or rejecting the test results.

(b) Determination of the test sample size also depends on the planned test method. Two commonly used methods for dormant reliability testing are fixed-length tests and tests terminated after a specified number of failures.

(3) Projection Methodologies:

(a) The issue of dormant reliability is part of a substantially larger problem—projecting mature system reliability early in the life cycle. There are two aspects to the projection problem, although the difference,

while real, may be very subtle. There must be an initial estimate of system reliability while later projections tend to be refinements of earlier projections.

(b) During the planning phase, methodologies will generally be restricted to those which can use nonmeasurement or limited part test data. Contractor predictions, judgment, comparability analyses, and simulation/modeling are the primary tools. During IOT&E, as test results become available, regression and surveillance and inspection methods can be added. These methodologies, with the exception of contractor predictions, will still be applicable during FOT&E.

(4) Validation and Verification (V&V). V&V of dormant reliability assessments is a difficult and time-consuming task. Field results will quite often require 5 to 10 years of exhaustive measurement, data collection, and analysis before dormant reliability predictions can be verified. Since the verification process provides the empirical feedback necessary to help validate the reliability projection methodology, the validation process is also accomplished over an extended period of time. Experience and data from similar systems can be used in the V&V process, but care must be exercised to ensure applicability of those data.

A2-5. Assessment Methodologies:

a. Current Methodologies. Current techniques for estimating dormant reliability generally fall under the three rather broad approaches of analytical prediction based on parts count and stress analysis, failure rate modification factors, and testing. Each of these approaches has advantages and disadvantages which warrant the cautious use of their results. A brief discussion of the three approaches follows:

(1) **Parts Count and Stress Analysis Prediction.** The parts count reliability prediction method assumes that the equipment failure rate is a function of the failure rates of its components or parts. This method is most applicable during the early design phase since it permits relatively easy comparison and evaluation of alternative designs. It is not likely that the operational tester will use this prediction method to estimate dormant reliability, but the system being developed will probably base early reliability predictions on this technique.

(2) **Failure Rate Modification Factors Prediction:**

(a) Numbers which are used to modify failure rates to account for varying stresses imposed by different applications and environments are generally known as failure-

rate modification or "K" factors. They are used to adjust a basic "known" failure rate for hardware when directly applicable experience data are not available. Factors have been developed and applied at all levels from generic parts to total systems.

(b) Failure rate predictions derived from K factors should be less accurate than rates derived from directly comparable experience. K factors probably have more applicability at the part or component level. At best, K factors may provide ballpark relationships between application environments.

(3) **Testing:**

(a) Testing provides the mechanism for obtaining empirical failure rate data. There are two driving considerations (discussed earlier) in any test program: sample size and required time. Two primary methods of testing are accelerated testing, which provides failure rate data in a relatively short period of time, and surveillance testing, which is done in real time and is more representative of the operational environment.

(b) Accelerated testing is of minimal use in dormant reliability because failures associated with dormancy may not occur during some short-time interval. This type of testing also has not been successful at the system level because of difficulties associated with constructing appropriate acceleration factors.

(c) Surveillance testing generally requires that a number of preproduction or production systems be placed in actual or simulated field storage conditions. Periodically, selected samples of these assets are removed from storage and examined for degradation from original specifications. The surveillance program's value to the operation lies in the availability of similar system data upon which to base a comparability analysis when developing an early system reliability prediction.

b. Summary:

(1) The current state of the art for dormant reliability prediction is not directly applicable to the OT&E environment. Most existing methods are oriented toward the development contractor's or SPO's needs and are concerned with developing, predicting, and validating accomplishment of specification requirements. It is rare to find dormant reliability requirements explicitly stated in user requirements documents.

(2) The current methodologies for projecting weapon systems dormant reliability early in the system's life cycle tend to focus at the part level. Prediction techniques rely on parts count and part stress analysis methods.

The expanding use of K factors to adjust or modify failure rates to account for varying stresses imposed by different applications and environments also seems to be more appropriate at the part level. Applicability at the system or even the major subsystem level requires further study and development. Accelerated testing techniques are also tailored to part testing. In fact, it is doubtful that accelerated testing could be effectively applied at the system level without significant additional study and analysis. Surveillance testing can also provide potentially useful data, but it will generally come from a similar program. Modeling/simulation can be used to investigate the dormant reliability impact on operational availability.

(3) There are many sources of useful data for the operational tester to use when developing early predictions of a new system's operational reliability. However, extreme caution must be exercised to ensure that the nature of the data (e.g., source, derivation, similarities/dissimilarities, etc.) is thoroughly understood.

A2-6. Tools and Techniques:

a. Availability and Applicability. Tools and techniques for estimating, predicting, projecting, or assessing dormant reliability during OT&E are limited in terms of their availability for use and their direct applicability in terms of the inherent limitations. Given this situation, select the best available, modify where possible, or suggest new methods to pursue in the future. Requirements exist for tools and techniques to establish initial dormant reliability estimates and to project those estimates to maturity. Additionally, methods to determine appropriate tests to obtain dormant reliability assessment data are needed.

b. Establishing Initial Estimates. A number of techniques for establishing initial dormant reliability estimates exist. Most of these techniques are applicable at the piecepart—rather than the system—level, base the estimate on comparable systems, or use adjustment factors. Discussions of some of the most frequently used techniques follow:

(1) MIL-HDBK 217E, Reliability Prediction of Electronic Equipment:

(a) MIL-HDBK 217E contains the most widely used methods for initial estimates of reliability. It applies mainly to electronic components at the piecepart level. There are, however, some considerations which may render this approach useful for projection purposes.

(b) Although MIL-HDBK 217E methods result in an estimate of inherent dor-

mant reliability generally not totally applicable to field conditions, system OR storage reliability may be adequately represented by this estimate. An understanding of the system under evaluation and the proposed maintenance concept will allow the analyst to determine the appropriateness of this method.

(c) The MIL-HDBK 217E technique may be useful when the system is composed of relatively few subsystems, e.g., a tactical missile. Once initial estimates of dormant reliability have been established for each subsystem, a system estimate can be built up from them.

(2) Pieceparts for Nonelectronics. Part reliabilities and piecepart methodologies for other than electronic devices are available in Rome Air Development Center and Army Missile Command handbooks. The parts tend to be aggregated at higher levels than those of the MIL-HDBK 217E listings (e.g., generators, pumps, actuators, regulators, rocket engines, valves). Thus, a buildup approach is further simplified. The drawbacks to these documents are that they have not received "MIL-STD" status and are slightly harder to procure. They are, however, in current common usage.

(3) Piecepart Surrogates. If very quick estimates are necessary, there are several estimating relationships which have been used. These estimating relationships essentially provide substitutes for an aggregated parts level. Substitute measures include such things as complexity, volume, weight, functions, and cost. Simple or weighted averages can also be substituted for an actual parts count. Substitute methods provide only a gross estimate of reliability and are generally used for very quick trade-off analyses by system developers. Documentation on these methods is virtually nonexistent.

(4) Comparability Analysis:

(a) Comparability analysis is a successful and recognized technique. There are, however, some constraints. The data base used, the skill of the person making the comparability decisions, various adjustments that must be made when 100-percent comparable data do not exist, and the ingenuity of the analyst applying the results are all limiting factors. Even with these, however, comparability analysis is probably the single best technique that can be used when firm reliability values based on actual system experience and data are not available.

(b) This approach requires detailed knowledge of the specific system under consideration as well as other systems/subsys-

tems which may be similar. Given that comparable or similar subsystems exist, the problem then becomes one of homing in on dormant reliability by subsystem. If data on dormancy for the similar systems do not exist, one is left with factoring operating failures to dormant failures, and this process is generally not very accurate. The need to collaborate with other agencies who maintain dormant data bases thus becomes imperative.

(5) **K Factors:**

(a) K factors discussed in paragraph 20.5 are adjustments from one condition or set of conditions to other conditions. In the general sense, the term adjustment factor is more appropriate, but the use of the designator "K" has become common to reliability engineering and reliability handbooks.

(b) It is impossible to generalize the applicability or validity of adjustment factors. First, the number, type, and application of adjustment factors are almost limitless. Second, the validity depends on the application itself. The use of adjustment factors tends to be more art than science and is therefore strongly influenced by the skill, expertise, experience, and ingenuity of the person using them. Indiscriminate or uninformed use of adjustment factors is dangerous.

(c) Several studies attempt to adjust from operating to nonoperating conditions. This particular adjustment appears to have very limited potential application unless done at the piecepart level. Results vary widely and there appears to be no universal application. Use of a system- or subsystem-level adjustment for operating to nonoperating failure rates should be used only as a last resort, at least until much more research has been accomplished.

(6) **Other Estimating Techniques.** There are several additional estimating techniques which have potential for application to the assessment of dormant reliability, but for the most part they are not proven and should be viewed only as possibilities. These techniques are based on adaptation or extrapolation of contractor screening and testing. These techniques include deriving estimates of dormant reliability from acceptance tests, accelerated stress and temperature tests, item shelf life, and power-on/power-off cycling.

c. Projections to Maturity:

(1) Projection methodologies are generally applicable to dormant reliability as long as the nature of dormancy is carefully considered as part of the process.

(2) In the ideal case, inherent dormant reliability, OR storage reliability, and dormant reliability by state (e.g., transport)

should be closely monitored from the first estimates and specifications forward to essentially plot a bathtub curve. The nature of dormancy and the weapon system development process are such that one would expect to see reliability changes appear in jumps or by lot. Thus, reliability growth curves should look more like step functions than smooth curves.

(3) Another aspect of the nature of dormancy that impacts projections relates to the definition itself. Dormancy is defined at the system level and permits only on-equipment maintenance and BIT or functional checks necessary to maintain the desired status. As a weapon system matures and requires maintenance for dormant failures, "old" parts and subsystems will probably be used for repair. These parts and subsystems may be experiencing age-related failures themselves. One might see an artificially early wearout of the system when repair is performed using parts and subsystems that are more likely to fail because of their own age.

d. Testing for Dormant Reliability:

(1) The nature of the dormancy problem is such that traditional test means and methodologies often do not apply. Individual subsystems of a given weapon system may not be amenable to all tests for the effects of dormancy. For example, power-on/power-off tests on rocket motors and warheads are not appropriate, whereas they would be appropriate for guidance units.

(2) From the OT&E perspective, it is critically important that AFOTTEC pursues early involvement and collaboration in the development/acquisition process. A real issue centers around deciding which tests are appropriate and necessary for AFOTTEC to conduct to assess system dormant reliability.

(3) The process involved in this decision is based on a straightforward and logical progression. First, early detailed knowledge of the system itself is necessary. Second, a review of the maintenance and operational concepts should be performed. If these concepts are not available, early collaboration with the development/user community will help in providing at least provisional concepts. From these concepts, a life cycle profile should be constructed to define hours the system is exposed to in each of its environments. Based on the life cycle profile, decisions can be made regarding the states of dormancy which are sensitive to OT&E and appropriate tests by system/subsystem. In addition, close monitoring of engineering change proposals and engineering fixes should provide an input into the decision-making process.

A2-7. Dormant Reliability Assessment Approach:

a. Advance Planning:

(1) Review program documentation from the SPO and contractor for critical issues and areas of risk associated with dormant reliability.

(2) Review operational and maintenance concepts for background.

(3) Ensure that the failure definitions to be applicable throughout testing are incorporated in appropriate program documentation, e.g., PMD, TEMP, TPO, contract, etc.

(4) Formulate the life cycle profile model.

(5) Ensure that a piecepart dormant reliability prediction is accomplished by the SPO or contractor. Review the prediction if one is already accomplished.

(6) Review system design for dormant reliability considerations.

(7) From initial reliability predictions, determine preliminary number of assets for system surveillance tests during OT&E and recommend that the assets be incorporated into the contract and SPO budget.

(8) Review the contract to determine if failure analyses are required. If failure analyses are not included, recommend contract amendment to include analyses.

(9) Review the contract and DT&E test plan for contractor-accelerated testing of pieceparts and subsystems. If accelerated testing is not included, recommend contract addition.

b. Detailed Test Planning:

(1) Review the current design and the current operations and maintenance concepts to update the life cycle profile, OT&E objectives, and test methods.

(2) Review failure analyses.

(3) Update the reliability prediction because of design or operation and maintenance concept changes.

(4) Review the failure modes, effects, and criticality analysis (FMECA) for updating OT&E test plan objectives and methodology.

(5) Recommend initiation of surveillance tests of subsystems and components.

(6) Accomplish detailed test methodology for appropriate system tests to address sensitive areas.

(7) Ensure that assets are identified for above tests.

c. OT&E:

(1) Review current design and current operational and maintenance concepts.

(2) Update the life cycle profile, as necessary.

(3) Review failure analyses.

(4) Update dormant reliability prediction for changes in system design and/or opera-

tional and maintenance concept changes.

(5) Compare DT&E and early component and subsystem accelerated and surveillance test data to preliminary OT&E data.

(6) Document deficiencies and review engineering fixes of the deficiencies.

(7) Compare test data for failure rates to scheduled inspection period.

(8) Review and analyze test equipment effectiveness.

d. FOT&E:

(1) Refine life cycle profile, as necessary.

(2) Develop FOT&E objectives if different from OT&E objectives.

(3) Establish new MOEs if necessary.

(4) Continue surveillance tests.

(5) Update failure rates and compare to predicted failure rate.

(6) Analyze and compare OT&E and production failure rates for statistical differences.

(7) Analyze DT&E (accelerated and surveillance tests) and production failure rates for statistical differences.

A2-8. Lessons Learned:

a. The notion of dormancy is well established, and clear definitions of dormant-related terminology within the context of the specific system being developed are essential to properly estimate and test for dormant system reliability.

b. Reliability prediction through analytical estimation and test techniques is possible. Although some areas have not been validated, they look promising. Both types of techniques cover the total spectrum of dormant reliability assessment. Therefore, begin by updating initial contractor estimates and transition to testing when practical.

c. Early formulation of the system's life cycle profile model is essential to the entire process of defining dormancy, structuring a comprehensive test program, and assessing the effects of dormancy on operational reliability and logistics reliability.

d. Reliability prediction based on the piecepart count method should be considered. During the early planning phase, it may provide the only source of available data.

e. Early involvement during the conceptual phase of the system acquisition cycle is essential.

f. A critical element of "dormant failure rate" for systems maintained under a wooden round concept appears to be induced failures. System reliability can be improved with a periodic test concept, provided the induced failure rate can be held to a low level.

g. Dormancy was defined as "Those states in which a system is not operating or is

being maintained in OR storage—including all on-equipment maintenance...." Since dormancy is not normally defined at the subsystem or lower level, parts and subsystems in storage are not included in the aging of the system.

h. Dormancy is defined at the system level

and permits only on-equipment maintenance and BIT or functional checks necessary to maintain the desired status. Therefore, parts and subsystems that are in storage are not considered subject to the effects of dormancy.

AVAILABILITY IN AIRCRAFT, AVIONICS, SIMULATORS, GROUND COMMUNICATION/WEATHER SYSTEMS, AND MUNITIONS

A3-1. Discussion:

a. Availability assessments of aircraft, avionics systems, munitions, simulators, ground communication, and weather systems differ in degree. In all cases, the assessment must begin with a clear understanding of the mission of the system, its critical components, its intended operational environment, and its maintenance concept. From this baseline, a test concept may be developed.

b. For aircraft assessments, the entire aircraft with all its systems and subsystems is assessed in terms of its availability. Systems and subsystems are important only to the extent that they contribute to the mission and support of the aircraft.

c. For avionics system assessments, the avionics system must perform its mission as part of the larger aircraft system. If the avionics system is critical to the mission of the aircraft, the impact of the avionics system's availability on the availability of the host aircraft must be assessed. If the avionics system is not critical to the mission of the aircraft, no availability assessment is required (nor is it desired).

d. Simulator assessments are unique in that simulators are normally procured in limited quantities and are not generally controlled by a production decision. These assessments are usually accomplished in conjunction with an AFSC-conducted qualification test as a combined QT&E/QOT&E IAW AFR 80-14. Generally, simulator assessments have two phases (in-plant and on-site) each with a separate "quick-look" report. Additionally, a maintainability demonstration is normally conducted during the on-site phase.

e. Ground communication/weather systems differ from aircraft and avionics in that they are generally required to operate 24 hours per day. These systems are frequently deployed to remote locations, thus adding a significant amount of transportation time to any maintenance requirement. Environmental factors such as weather require increased consideration during test planning. Technology has developed to the point where these systems may continue to fulfill mission requirements with significant portions inoperable. Finally, repair of these systems can frequently be performed while they continue to operate. All of these differences combine to change specific portions of the availability assessment. When C³I systems are part of an aircraft, they are treated as avionics.

f. Munitions and missiles include a wide variety of systems that can be used for a number of different missions and range in complexity from ammunition to cruise missiles. In general, missiles and munitions must be able to withstand long periods of storage with little maintenance and still perform with high reliability. Missiles differ from munitions in having a self-contained propulsion system to move from the launch point to the target.

A3-2. Availability Test Objectives:

a. The following paragraphs discuss the availability objectives AFOTEC uses for aircraft, avionics, simulators, ground communication/weather systems, and munitions. The structure of the test plan and the phrasing of each objective will vary depending on the system being assessed, the type of OT&E conducted, and statement of the operational requirement for availability.

b. The goal of availability assessment is to determine if the system can meet the user's specified availability requirements. Availability is a measure of the degree to which an item is in an operable and committable state at the start of a mission when the mission is called for at a random point in time. Availability is a function of the system's reliability and maintainability characteristics and on its logistics supportability. Measures of availability are generally expressed as percentages, e.g., either the percentage of times a system is capable of performing its mission or the percentage of time a fleet is capable of performing its mission. During IOT&E, little or no meaningful availability data may be available. Under these circumstances, the emphasis of the availability assessment will shift from quantitative to qualitative. There are some cases where data from the combined DT&E/IOT&E test period may be used to help evaluate availability.

c. Examples of aircraft (F-X) availability objectives are:

(1) Assess/evaluate the F-X operational availability.

(2) Assess/evaluate the F-X operational availability in support of mission Y.

d. Examples of avionics system (AV-1) availability objectives are:

(1) Assess/evaluate the AV-1 operational availability as it affects readiness for mission X.

(2) Assess/evaluate the AV-1 operational

availability as it affects readiness for mission X when installed on host system Y.

Note: If AV-1 is not required for any mission (either as stand-alone or when installed on a host system), there should be no availability objective started in the test plan. The reason for this is availability has little operational meaning.

e. Example of simulator availability objective: Assess/evaluate simulator X availability.

f. Example of ground communication/weather system availability objective: Assess/evaluate system X operational availability.

g. Example of munitions availability objective: Assess/evaluate munition X operational availability.

A3-3. Availability Measures of Effectiveness:

a. **General.** The selection of MOEs for availability should be based on the terms found in AFP 57-9 and the ORD. These MOEs are extremely difficult to measure during IOT&E where many support elements are not representative of the operational environment. During a typical IOT&E, extensive modeling is required to estimate and project these availability measures. During FOT&E, with representative support elements in an operational organization, these MOEs can be measured directly.

b. Aircraft and Avionic System Availability MOEs:

(1) **Sortie Generation Rate (SGR).** SGR is the number of sorties that can be flown per aircraft per day under specified operational and maintenance concepts. A sortie starts when the aircraft begins to move forward on takeoff and ends when the aircraft returns to the surface and either the engines are stopped, the aircraft is on the surface for 5 minutes (whichever occurs first), or a change is made in the crew. SGR is calculated through direct measurement or from simulation results depending on the realism of the test environment. Because most aircraft can perform several missions, it may be necessary to calculate several SGRs to represent the full range of operational mission requirements. The following formula applies:

$$\text{SGR} = \frac{\text{total number of sorties/}}{\text{total number of aircraft}} \text{ number of days}$$

This measure typically applies to the total aircraft system and is not used for avionics systems and simulators. However, the im-

part of a new avionics system on the host aircraft's SGR may be measured.

(2) **Fully Mission Capable (FMC) Rate.** The FMC rate is the percentage of possessed hours that a system is capable of performing all its assigned peacetime and wartime missions. The critical identification of components is required for the missions to determine the status of the aircraft. The following formula applies:

$$\text{FMC} = \frac{\text{number of hours FMC}}{\text{possessed hours}}$$

This MOE has the advantage of being a well-established parameter, with the data necessary to calculate it generally available through automated systems in the operational environment. However, the FMC rate should not be directly measured during IOT&E because support elements will not be representative of the intended operational environment. Instead, simulation should be used as a basis for calculating the FMC rate during IOT&E.

(3) **Partially Mission Capable (PMC) Rate.** The PMC rate is the percentage of possessed hours that a system is capable of performing at least one, but not all, of its assigned peacetime and wartime missions. The critical identification of components is required for the missions to determine the status of the aircraft. For analysis purposes, the PMC rate may be divided into categories as follows: PMC for maintenance (PMCM), PMC for supply (PMCS), and PMC for both maintenance and supply (PMCB). The following formula applies:

Note: Care must be taken if PMC is divided out because of the difficulty in separating the data during test.

$$\text{PMC} = \frac{\text{number of hours PMC}}{\text{possessed hours}}$$

As before, the PMC rate should not be directly measured during IOT&E. Instead, simulation should be used as a basis for calculating the PMC rate during IOT&E.

(4) **Mission Capable (MC) Rate.** The MC rate is the percentage of possessed hours a system is capable of performing any or all of its assigned missions. The following formula applies:

$$\text{MC} = \frac{\text{number of FMC hours} + \text{number of PMC hours}}{\text{possessed hours}}$$

The MC rate should not be directly measured during IOT&E. Simulation should then be

used as a basis for calculating the MC rate.

c. Simulator Availability MOE. For simulators, overall availability has little meaning. Because simulators are scheduled and used by individual mission categories, availability for each mission category must be measured and reported. A typical measure is the ratio of successful missions to scheduled missions. The definition of what "successful" means should be included in the test plan. A weighted availability rate may be calculated by using planned simulator utilization rates.

d. Communication/Weather System Availability MOE. Uptime ratio (UR) is the most common measure of availability for ground communication/weather systems. It is the equivalent of mission-capable rate for aircraft and avionics systems. However, since possessed time equals planned operating time for C³I systems, an additional formula may be used in its calculation. A word of caution: since the IOT&E environment is seldom typical of the operational environment, the MDT portion of the first formula should be derived by simulation and not measured directly. The following formulas may be used to calculate UR:

$$UR = \frac{\text{uptime}}{\text{uptime} + \text{downtime}}$$

$$UR = \frac{MTBCF}{MTBCF + MDT}$$

Other formulas are defined in AFP 57-9, but these show the relationships involved.

e. Munition Availability MOEs:

(1) **Sortie Surge Generation.** Sortie surge generation is the number of operable munitions/missiles that can be assembled, delivered, and loaded to meet wartime sortie requirements. The aircraft type; quantities of personnel, aircraft, support equipment, and munitions; and time constraints are based on operational requirements and should be established by the using command. Sortie surge generation can be calculated through direct measurement but is normally estimated using a simulation model because of the lack of assets to conduct a representative generation during OT&E.

(2) **Mission-Capable (MC) Rate.** MC rate is used only for systems that can be tracked using AFR 65-110 or similar reporting systems. Many missiles/munitions are tracked by inventory reporting systems; hence, this term may not apply. In cases where an MC requirement is stated, the following formula is used:

MC = FMC + PMC, where

$$FMC = \frac{\text{number of hours FMC}}{\text{possessed hours}}$$

and

$$PMC = \frac{\text{number of hours PMC}}{\text{possessed hours}}$$

(3) **Asset/Stockpile Availability.** A base-level asset/stockpile availability (A_s) is the ratio of the number of munitions on-hand to the number of munitions assigned. The number of munitions on-hand normally excludes those on-hand assets which are a disassembled for storage and/or testing (i.e., disassembled munition is normally not an available munition. Once assembled and checked out, it becomes available). Equivalent definitions are used for theater-level stockpile availability and force-level stockpile availability. The following general formula applies:

$$A_s = \frac{\# \text{ of available munitions}}{\text{total munitions in inventory}}$$

A3-4. Availability Data Requirements:

a. Data elements required to calculate the above MOEs vary with the test environment.

b. During IOT&E, the test environment usually does not represent the intended operational environment. As a result, direct measurement (demonstrated availability) cannot be used to produce operationally meaningful estimates of availability. Instead, data elements are collected from similar systems, testing, and contractor estimates. These data elements are then used in simulation models to estimate operational availability. The following are examples of these data elements:

- (1) Mean time between maintenance (MTBM).
- (2) Mean time between critical failures (MTBCF).
- (3) Mean repair time (MRT).
- (4) Mean downtime (MDT).
- (5) Logistics delay times.
- (6) Administrative delay times.
- (7) Operational mission scenarios/minimum essential subsystem lists (MESL).
- (8) Expected manpower.
- (9) Expected sparring.
- (10) Expected support equipment.
- (11) Number of each type of mission attempted (simulators).
- (12) Number of each type of mission completed (simulators).
- (13) Environmental factors (ground com-

munication/weather systems).

(14) Expected inventory size/authorization and delivery schedules (munitions).

c. During FOT&E, the test environment is generally representative of the intended operational environment. Therefore, the data elements listed below may be used directly to calculate the MOEs:

(1) FMC hours, PMC hours, and NMC hours.

(2) Number of sorties.

(3) Number and type of assigned aircraft, personnel, and SE.

(4) Number of possessed hours/days.

(5) Uptime hours, downtime hours (ground communication/weather systems).

(6) Inventory size (munitions).

d. As with data elements, data sources vary with the test environment.

(1) During IOT&E, the data elements are available from:

(a) Contractor reports.

(b) Data from other OT&E objectives (e.g., reliability and maintainability).

(c) Operational and maintenance concepts.

(d) Weapon system and equipment support analysis (WSESA) or logistics support analyses (LSA)

(e) System effectiveness data system (SEDS).

(f) Similar systems in test or deployed.

(2) During FOT&E, the data elements are available from:

(a) AFR 65-110, Aerospace Vehicle and Equipment Inventory, Status, and Utilization Reporting System (AVISURS).

(b) Maintenance management information and control system (MMICS).

(c) Status data from OT&E logbooks.

(d) Automated data systems (CAMS, Micro Omnivore, etc.).

SPACE SYSTEMS ASSESSMENT

A4-1. Discussion. An operational test and evaluation for a space system includes the projection of its operational suitability and how well the ground segment can be operated and maintained by military or contractor or contractor personnel in the operating environment. This includes identifying those areas where improvements will be desirable as early in the system's development or life as possible. Factors included in the evaluation are the space system's availability, reliability, maintainability, and logistics supportability. Where applicable, the same factors may be assessed for subsystems to highlight the system's suitability performance in specific areas.

a. General Space System Segments.

A space system is generally divided into three segments for planning and operational purposes: control, mission, and space. They are defined as:

(1) **Control Segment.** The related hardware, software, and procedures necessary for command and control of a satellite's, spacecraft's, or space system's health and status.

(2) **Mission Segment.** Hardware, software, procedures, and/or data needed to utilize the payload of a satellite, spacecraft, or space system. This segment may provide communications between the payload and the user, data acquisition from the spacecraft, and data processing and data transfer to the users. These space-to-ground links may be characterized by the requirement for extremely high levels of availability frequently achieved through redundancy. This segment may include user control of the mission segment.

(3) **Space Segment.** That portion of a space system which is intended to operate in space including the associated program-related elements of the launch subsystem (if applicable).

(a) The space segment includes the units which will be deployed in space and the vehicle used to deploy it. This is the flight hardware to which traditional suitability elements are more applicable. The limited inventory and activity levels currently experienced in the space segment have generated the requirement for almost total contractor preparation and maintenance of the system. Operationally reusable/recoverable systems may require Air Force maintenance and logistics support and will require a more classic approach to operational suitability evaluation.

(b) Space segments for the most part

involve procurement of a few items over an extended period of time. Frequently, procurement and management techniques used to acquire space segments are based on mission success or on-orbit performance incentive contracts. These acquisition methods limit hands-on participation by DOD personnel in contractor development and testing.

(c) Since space segment testing is normally accomplished by contractor personnel, DT&E and OT&E test objectives and data requirements must be defined as early as possible and provided to the SPO prior to contract initiation.

b. Space Program Management. In addition to being the implementing agency, AFSC's Space Systems Division (SSD) often assumes the role of using, operating, or supporting agency. Additionally, some space systems do not follow standard weapon system acquisition processes. For example, frequently there is no production decision. For these reasons, test policy may have to be tailored to meet USAF and DOD directives.

c. Suitability OT&E of Space Systems:

(1) An increasing level of Air Force activity in space is anticipated, with the consequent need for increasing levels of Air Force maintenance and logistics support. In addition to the increasing responsibilities of the Air Force involvement in space regarding these suitability issues, projected plans to deploy systems and crews to space on an operational basis will generate the type of suitability concerns traditionally addressed in OT&E.

(2) Because of the highly specialized nature of past space activities, most current systems support is contractor-furnished. The development of future Air Force operational space systems is expected to require increased Air Force operational, maintenance, and logistics support. The level of Air Force involvement will be a prime consideration in developing test objectives and MOEs from critical issues.

(3) Although there are many problem areas involved in conducting an operational suitability evaluation of a space system, early recognition of them and adequate planning will reduce their impact. The complexity of each of the segments listed above and the degree of Air Force participation in various segments will generate different critical issues, objectives, and MOEs for each segment. OT&E of each segment may be conducted as a separate evaluation. Testing of the control segment is similar to ground

communication systems.

A4-2. Integration of Segments and Objectives into Total System Evaluation:

a. Because space system evaluation involves the assessment of the control, mission, and space segments through somewhat independent objectives and MOEs, the total system suitability evaluation must somehow integrate each of the segment assessments. This process requires knowledge of how the segments interact with each other, what the various impacts of segment downtime will have on the total system, and the impact of various time delays on system performance. For example, an item of control equipment may have a 99-percent availability rate but is so critical to total system performance that a 99.9-percent availability rate is required. Alternatively, a 2-month launch preparation

period may be acceptable because redundant systems are sufficient to allow that delay.

b. A method of integrating the evaluation of each segment is through use of simulation to model the entire system. Suitability performance parameters generated by a model are the total system availability or readiness during given operational periods and the capability of failure-free operational status over a given period.

A4-3. Evolution of Space Systems Assessment. AFOTEC is assessing the operational suitability of many space systems; nevertheless, the process of evaluating space systems is still in its infancy. In essence, it is a combination of various techniques discussed in Part Three. As further experience is acquired through the evaluation of space systems, this attachment will be expanded.

REFERENCE DOCUMENTATION

A5-1. Current DOD and USAF Policy Guidance. This attachment lists DOD and Air Force policy guidance documentation relating to the operational suitability evaluation requirements during the acquisition of major weapon systems. The information is subject to frequent changes. The reader should ensure that only the current edition of publications is used.

A5-2. Office of Management and Budget (OMB) Direction:

a. In April 1976, the OMB published Circular A-109, Major Systems Acquisitions. It prescribed policies for all executive branch agencies involved in acquiring major systems. It is based on the general policy that federal agencies, when acquiring major systems, will express needs and program objectives in mission terms and not equipment terms. The stated major system acquisition management objectives were that each agency would:

(1) Tailor an acquisition strategy for each program that encompasses demonstration, test, and evaluation criteria.

(2) Maintain a capability to assess acquisition cost, schedule, and performance experience against predictions and provide such assessments at key decision points.

b. As a result of OMB Circular A-109, the DOD and the Air Force revised their acquisition policies.

A5-3. Department of Defense Directives and Instructions (DODD/DODI):

a. **DODD 5000.1, Defense Acquisition.** This directive establishes a disciplined management approach for acquiring systems and material that satisfy the operational user's needs. The policies in this directive establish a disciplined approach for integrating the efforts and products of the Department of Defense's requirements generation; acquisition management; and planning, programming, and budgeting systems.

b. **DODI 5000.2, Defense Acquisition Management Policies and Procedures.** This instruction establishes an integrated framework for translating broadly stated mission needs into stable, affordable acquisition programs that meet the operational user's needs and can be sustained, given projected resource constraints. The instruction also establishes an event-oriented, rigorous management process for acquiring quality products that emphasize effective acquisition planning, improved communications with users, and aggressive risk management by

both government and industry.

c. **DOD 5000.2-M, Defense Acquisition Documentation and Reports.** This manual contains procedures and formats used to prepare various acquisition category I and II reports, including milestone documentation, periodic in-phase status reports, and statutory certifications.

A5-4. Air Force Regulations (AFR) and Pamphlets (AFP). Numerous Air Force documents provide guidance for a system's acquisition. Air Force documents of particular interest in relation to operational suitability evaluation are AFRs 57-1, 66-14, 80-14, 800-2, 800-8, and 800-18. Synopses of these documents are presented below.

a. **AFR 55-43, Management of Operational Test and Evaluation.** AFR 55-43 provides overall guidance for management of a test and evaluation program. It outlines the responsibilities of various participating agencies and the general process of test planning and execution and describes the development of test objectives and evaluation criteria. For example, it contains such subjects as required test documentation related to acquisition milestones, test design for individual elements of operational suitability, test report formats, and resource management forms. AFOTTEC Supplement 1 to this regulation provides additional guidance to HQ AFOTTEC and AFOTTEC field units.

b. **AFR 57-1, Operational Needs, Requirements, and Concepts.** This publication outlines Air Force policies, procedures, and responsibilities for identifying, processing, and approving operational requirements which result in research, development, test, and evaluation (RDT&E) or procurement appropriations. AFR 57-1 describes the criteria, content, format, and approval process for mission need statement (MNS), and operational requirements documents (ORD). It also provides procedures for preparing a mission need statement (MNS), processing and coordinating joint service operational requirements (JSOR), international cooperative programs including North Atlantic Treaty Organization (NATO) and North American Aerospace Defense (NORAD) Command program within the context of the overall acquisition process.

c. **AFP 57-9, Defining Logistics Requirements in Statements of Operational Need.** Defines procedures and outlines guidance for including readiness and

detailed explanations of readiness-related terms and the integrated logistics support elements with discussions and examples of their development and inclusion in MNSs.

d. AFR 65-110, Aerospace Vehicle and Equipment Inventory, Status, and Utilization Reporting System (AVISURS). This regulation establishes inventory, status, and utilization reporting policy and procedures for selected aerospace vehicles and equipment.

e. AFR 66-1, Maintenance Management Policy. This regulation establishes the maintenance management system for all Air Force and Air Reserve Forces activities which maintain aircraft, missiles, munitions, support equipment, avionics, training equipment, and communications and electronics equipment. It implements the provisions of AFR 66-14 which pertain to on-equipment and off-equipment maintenance.

f. AFR 66-14, Equipment Maintenance Policies, Objectives, and Responsibilities. AFR 66-14 sets up the principles to be used in developing maintenance concepts and outlines the policies and procedures for managing the Air Force equipment and maintenance program.

g. AFR 80-14, Test and Evaluation: This regulation outlines the policy and procedures for managing test and evaluation activities during the development, production, and deployment of defense systems in the Air Force. It assigns test and evaluation responsibilities to the implementing command, AFOTTEC, and the operating and supporting commands. AFR 80-14 states that OT&E is conducted in as operationally representative condition as possible to estimate or to refine estimates of a system's operational effectiveness and suitability and to identify operational deficiencies and the need for modifications.

h. AFR 800-2, Acquisition Program Management. This regulation states the policy for managing all Air Force acquisition and modification programs. It implements DODD 5000.1 and DODI 5000.2, establishes policy on acquisition programs, and outlines participating agency responsibilities.

i. AFR 800-8, Integrated Logistics Support (ILS) Program. This regulation states the Air Force policy for ILS management and defines requirements for applying ILS throughout the life cycle of systems, equipment, and modification programs.

j. AFR 800-14, Life-Cycle Management of Computer Resources in Systems. Establishes policy for the acquisition and support of computer equipment and computer programs employed as dedicated elements, subsystems, or components of systems devel-

oped or acquired under the program management concept established in AFR 800-2.

k. AFR 800-18, Air Force Reliability and Maintainability Program. This regulation establishes the policy for developing, acquiring, maintaining, modifying, and operating Air Force systems that are reliable and maintainable. Air Force R&M policy pertains to any action, procedure, technique, or design that enhances system combat effectiveness and operational suitability by making the system either more reliable or easier to maintain, or both.

A5-5. AFOTTEC Regulations (AFOTTECR) and Pamphlets (AFOTTECP):

a. AFOTTECR 23-1, Missions and Organizational Structures. This regulation reflects the approved functional responsibilities and organizational structures necessary to accomplish the mission of AFOTTEC command, staff, and operating elements.

b. AFOTTECP 171-203, Volume II, Micro Omnivore Users Pamphlet. This pamphlet describes the operating procedures for each of the eight primary Micro Omnivore functions: Logon, Menu Handler, Telecommunications, Data Base Update, Analysis Query, Manual Input, and Utilities.

c. AFOTTECP 400-2, Qualitative Facility Evaluation. This pamphlet provides procedures for conducting qualitative evaluations of facilities.

d. AFOTTECP 800-1, OT&E Lessons Learned Program. This regulation implements AFR 800-13, Air Force Feedback Policy. It establishes AFOTTEC policy, assigns responsibilities, and outlines procedures for submitting, processing, storing, and retrieving lessons learned reports.

e. AFOTTECP 800-2, Volume 1, Management of Software Operational Test and Evaluation. This pamphlet is the first volume of a series of pamphlets prepared by the Software Evaluation Division at HQ AFOTTEC. The volumes provide the software evaluation manager and the deputy for software evaluation information needed for planning, conducting, and reporting on OT&E of mission critical software. The pamphlets in the series are:

(1) AFOTTECP 800-2, Volume 1, Management of Software OT&E.

(2) AFOTTECP 800-2, Volume 2, Software Support Life Cycle Process Evaluation Guide.

(3) AFOTTECP 800-2, Volume 3, Software Maintainability Evaluation Guide.

(4) AFOTTECP 800-2, Volume 4, Software Usability Evaluator's Guide.

(5) AFOTTECP 800-2, Volume 5, Soft-

ware Support Resources Evaluation Guide.

(6) AFOTTECP 800-2, Volume 6, Software Maturity Evaluation Guide.

(7) AFOTTECP 800-2, Volume 7, Risk Assessment for Software Supportability Guide (Draft).

A5-6. Other Command Regulations and Pamphlets:

a. General. Other commands often publish supplements to the preceding regulations. Though too numerous to list here, AFOTTEC logistics personnel should consult with their counterparts when needing information contained in command-specific regulations and pamphlets. Also, the LG reference library located in LG3 contains a copy of commonly used guidance documents from other commands. The following documents are key reference sources for the information contained in this pamphlet.

b. AFLCR 66-15, Product Performance. This regulation contains policy and requirements for data system maintenance and procedures on using and analyzing deficiency data reported on Air Force systems and equipment.

c. AFLCP/AFSCP 800-34, Acquisition Logistics Management. This pamphlet is a publication of AFLC/XXR and AFSC/SDD which provides a comprehensive source of reference information for acquisition logistics matters within AFLC and AFSC. It is also a very useful source of information for all commands involved in the acquisition logistics process.

A5-7. Department of Defense Documentation:

a. Justification for Major System New Starts. Each major system acquisition program requires a JMSNS, to be approved by the SECDEF. DOD components shall prepare a JMSNS to document major deficiencies in their ability to meet mission requirements. The most important part of the JMSNS is the evaluation of current and planned capabilities in relation to the projected threat. The evaluation can be based on a deficiency in the existing capability, such as excessive manpower, logistics support requirements, ownership costs, inadequate system readiness, or mission performance. In addition, key boundary conditions for satisfying the need are identified, such as logistics, safety, and manpower considerations. The JMSNS is the document on which the Milestone I decision is based. The MNS states the user's needs, and the JMSNS states those needs in relation to the mission elements in a manner that allows a Mile-

stone I review and decision. (Source: DODI 5000.2.)

b. System Concept Paper. The SCP is required documentation of Milestone I. It supports the JMSNS and states the direction needed from the Secretary of Defense. It describes the concepts explored up to Milestone I, including any that may have been rejected; the basis for narrowing the list of concepts, when appropriate; and the results of the system and threat interactive analysis. The SCP describes the recommended alternative concepts to be carried forth into the demonstration and validation (D&V) phase. It identifies mission requirements that significantly impact system design features and support concepts. DODI 5000.2 contains the specific format for an SCP. The annexes contain system performance thresholds and resource requirements for the acquisition program.

c. Test and Evaluation Master Plan (TEMP):

(1) The TEMP is the primary document used in the OSD review and decision process to assess the adequacy of the planned testing and evaluation. As such, the TEMP must be of sufficient scope and content to explain the entire T&E program. The DOD component (in the Air Force, usually AFSC) shall prepare and submit, before Milestone I and each subsequent milestone, a TEMP for OSD approval.

(2) Each TEMP submitted to OSD must relate the T&E effort directly to technical risks, operational issues and concepts, system performance, availability, reliability, maintainability, logistics requirements, and major decision points.

(3) The TEMP should include the key operational and technical effectiveness and suitability characteristics, but it is not limited to the characteristics identified in the decision milestone documentation. These characteristics must be clearly defined, and the program milestones at which the thresholds will be or have been demonstrated will be indicated. Prior to Milestone II, while tradeoffs of characteristics are underway, it may not be possible to establish firm goals or thresholds. In this case, those aspects of performance will be identified which are critical to the ability of the system to accomplish its mission. (Source: DODD 5000.3.)

d. Secretary of Defense Decision Memorandum (SDDM). The SDDM documents each milestone decision, establishes program goals and thresholds, reaffirms established needs and program objectives, authorizes exceptions to acquisition policy

(when appropriate), and provides the direction and guidance to OSD, organization of the joint chiefs of staff (OJCS), and the DOD component for the next phase of acquisition. Upon approval of the JMSNS by an SDDM and designation of a system as major, the DOD component must take necessary programming action to incorporate required resources into the PPBS. (Source: DODI 5000.2.)

e. Decision Coordinating Paper (DCP):

(1) The DCP provides top-level documentation for use by DAB members in arriving at a recommendation for the SECDEF at Milestone II (and Milestone III if required). It includes a program description, revalidation of the mission need, goals and thresholds, a summary of the DOD component's acquisition strategy, system and program alternatives, and issues affecting the decision.

(2) DODI 5000.2 governs the form and content of the DCP. Its format and annexes are the same as for the SCP. At Milestone II, emphasis should be placed on goals and requirements related to system readiness, associated cost, and related logistic risks. At Milestone III, logistic resources and capability to be acquired during production and their relationship to system readiness and cost objectives should be highlighted. Relevant changes to information provided in previous program documentation should be addressed at each milestone. (Source: DODI 5000.2.)

f. Integrated Program Summary (IPS):

In accordance with DODI 5000.2, the IPS provides more specific information than the DCP regarding the implementation plan of the component for the complete acquisition cycle, with emphasis on the phase the program is entering. DODI 5000.2, attachment 2 to enclosure 5, titled: Manpower, pertains to logistics. This attachment includes:

(1) A list of each unit type that will operate the system and primary system elements, including unit types that provide intermediate maintenance of system components. Examples of unit types are "Fighter Squadron" and "Munitions Maintenance Squadron."

(2) For each unit type, the manning required to satisfy the most demanding mission (normally combat employment but may be precombat readiness for certain naval vessels and systems on alert).

A5-8. Operating Command/HQ USAF Documentation. The ability to perform OT&E which is responsive to program decision needs depends on the availability of system-specific information. For major systems, a series of required documents is

defined to provide this information.

a. Statement of Operational Need. The operating command develops the MNS to identify an operational deficiency and state the need for a new or improved capability for USAF forces. Operational needs are based on short-term and long-term capability objectives and may result from a projected deficiency or obsolescence in existing capabilities, a technological opportunity, or an opportunity to reduce operating and support costs. The MNS provides the basic justification to initiate program acquisition or modification proposals. If the evaluation of the formal MNS indicates that Secretary of Defense (SECDEF) or the Secretary of the Air Force (SAF) approval is necessary, HQ USAF prepares a JMSNS to support the need and submits it to the SECDEF or SAF, as appropriate. (Source: AFR 57-1.)

b. Operational Requirements Document (ORD). The operating command submits a ORD for each funded program tested in the Program Management Directive. The ORD is the requirements and planning document prepared to address operational and support needs. It amplifies and refines the MNS. A major part of the ORD is the requirements correlation matrix (RCM). The RCM is a multicolumn spreadsheet whose purpose is to document and track the formulation of and changes to user requirements as they evolve through the program acquisition process. (Source: AFR 57-1.)

c. Program Management Directive (PMD). The PMD provides Air Staff direction for acquisition and modification programs. It directs the actions of the implementing, using, supporting, and other participating commands. It is a living document that is prepared when the program is initiated and is updated throughout the program. The PMD contains evaluation criteria (goals and thresholds) established in the SDDM. (Source: AFR 800-2.)

A5-9. Implementing/Supporting Command/MAJCOM Documentation:

a. Program Management Plan (PMP):

(1) The PMP is the baseline management document used for implementing and planning an acquisition program. It shows the schedule of events and necessary resources. The program office prepares the PMP, and unless otherwise directed in the PMD, the program manager approves it. The PMP contains only that information the program manager deems necessary.

(2) The PMP directs participating organizations by identifying and defining their participation and support responsibilities.

ities. Where OT&E is concerned, however, the PMP can only reflect the IOT&E program agreed upon by the responsible OT&E agency and the program manager and the FOT&E program planned by the OT&E agency.

(3) The PMP contains the R&M management plan. (Source: AFSCP 800-3, A Guide for Program Management.)

b. Acquisition Strategy. Acquisition strategy is the conceptual basis of the overall plan that a program manager follows in program execution. It reflects the management concepts that will be used to direct and control all elements of the acquisition and responds to specific goals and objectives of the program. It ensures that the system being acquired satisfies the approved mission need. The acquisition strategy will evolve through an iterative process, becoming increasingly definitive in describing the relationships of management, technical, business, resource, force structure, support, test, and other aspects of the program.

c. Integrated Logistics Support Plan (ILSP). The program manager and the deputy program manager for logistics (DPML) or integrated logistics support manager (ILSM) develops and uses the ILSP to manage the ILS process. This includes the horizontal integration of the ILS elements (i.e., with each other), as well as their vertical integration into the various aspects of program planning, engineering, designing, testing, evaluating, production, and operation. It also includes the integration of support elements with the mission elements of a system throughout its life cycle and is updated as the program evolves. The ILSP is a part of the PMP and, when approved, becomes directive on all participating agencies. (Sources: AFR 800-8 and AFLCP/AFSCP 800-34.)

d. Integrated Support Plan (ISP). The ISP is an iterative document prepared by a contractor for the acquiring activity. It describes the contractor's plan for managing the contractual ILS program, for complying with the specific contractual ILS requirements, and for planning any operational support functions assigned to the contractor. (Sources: AFR 800-8 and AFLCP/AFSCP 800-34.)

e. Logistics Support Analysis (LSA). The LSA is an analytical logistics effort within the systems engineering process to identify, define, analyze, quantify, and process logistics support requirements. The logistics support analysis record (LSAR) is the source of validated, integrated, and design-related logistics data for an acquisition program. The system contractor performs

LSA when required by the contract statement of work. There are four functions of the LSA process:

- (1) Identify the qualitative and quantitative logistics considerations.
- (2) Influence the system and equipment design for logistics considerations.
- (3) Communicate requirements and provide an integration influence.
- (4) Assess the achievement of logistics objectives.

(Sources: AFR 800-8, AFLCP/AFSCP 800-34, and MIL-STD 1388.)

f. Contract Statement of Work (SOW):

(1) The SOW provides an excellent source of information for those involved in test and evaluation. It spells out what the contractor is to provide in quantitative and qualitative terms and also specifies what system/subsystem testing is required and in what kinds of environments. Categories of information of specific interest will include reliability, maintainability, and supportability programs; goals; thresholds; demonstration plans; growth projection methodologies; support equipment; work breakdown structure; reporting requirements; life cycle cost plans; and logistics support plans.

(2) The results expected from the contractor will provide the baseline for system performance expectations, since they will define parameters; establish a set of expected suitability parameter values under specified environment conditions; and map out the reliability (or reliability growth) required to be demonstrated at various times during system development, production, and deployment. All of these values will be based on the system operational and maintenance concepts approved at the time of contract award. These values will normally be "inherent" values, representing the best performance a system may be expected to achieve. They must be modified to reflect the operating concepts and environments expected in field system use. (Sources: DODDs 5000.39 and 5000.40; AFRs 800-8 and 800-18, and AFLCP/AFSCP 800-34.)

g. Work Breakdown Structure (WBS):

(1) One of the most useful management tools for program managers in both DOD and industry is the WBS. Both groups of managers need total program visibility and timely data on program progress and problem areas. A WBS provides the framework for the required management visibility, cost estimating, and data reporting in a manner directly related to the systems engineering process.

(2) As the term implies, a WBS breaks

a total job or program into its component elements. These elements can then be displayed to show their relationship to each other and to the program as a whole. A program WBS reflects the systems engineering and management planning processes during development and production of a particular system. It provides a schematic portrayal of the products (hardware, software, services, and other work tasks) that completely define the program. It provides a means for effective management planning and implementation by providing the various functional managers of a program (those who are involved in development, production, finance, procurement, and logistics) with a common reference framework for communicating and making decisions. AFR 800-17 established the policy for developing and applying WBS in the acquisition of defense materiel. (Sources: AFLCP/AFSCP 800-34.)

h. Reliability and Maintainability (R&M) Management Plan. The R&M management plan is developed in accordance with AFR 800-18 by the program manager in concert with other activities of the implementing, supporting, and operating commands and test agencies and is issued prior to release of request for proposal (RFP). This management plan should be part of the PMP. Contents will include R&M program objectives, responsibilities of various Air Force activities, procedures for determining and achieving R&M objectives, data requirements/analysis procedures, flow of test and contractor R&M data, internal Air Force R&M evaluation and reporting procedures, and prediction of R&M and logistics performance values. (Source: AFR 800-18.)

i. Life Cycle Cost Management Program/Plans:

(1) AFR 800-11, Life Cycle Cost Management Program, establishes the life cycle cost management program. The objective of the program is to ensure that the Air Force acquires products which satisfy operational needs while providing the lowest feasible life cycle cost. Basic policy is that the Air Force will consider the full impact of life cycle costs in making decisions associated with selection, design, development, acquisition, modification, repair, or use of defense materiel.

(2) Life cycle cost is the total cost to the government of an item or system over its life. It includes acquisition costs (research and development, test and evaluation, and production including the initial investment for a product support capability) and recurring operating and support costs or "cost of ownership" (operations, maintenance, and other support). Disposal costs are sometimes

included when the ultimate salvage of equipment has some residual value or a significant disposal cost.

(3) The program manager is responsible for implementing a life cycle cost management program. Review of any plans and documentation resulting from program implementation may provide insight into the "cost driver" areas of concern which might be evaluated during OT&E. (Sources: AFLCP AFSCP 800-34.)

j. System Maintenance Concept. AFR 66-14 contains guidance for the preparation of the system maintenance concept. The maintenance concept forms the basis for all logistics planning and, along with the operational concept, establishes the framework for hardware design. As the design becomes more definitive, a series of logistics analyses are performed to substantiate proposed design changes and to develop a maintenance plan for operational application. The fully developed maintenance plan is validated during DT&E and OT&E. The maintenance plan, when compatible with the production configuration, is provided to the supporting and operating commands. (Sources: AFRs 57-1 and 66-14.)

k. Lessons Learned Files:

(1) ALD/ER is responsible for developing and operating a "lessons learned" system to perform the vital feedback function. The Logistics Performance Division (ALD/ERT) manages the lessons learned program and the corporate repository. The repository contains information (submitted by any organization) relevant to a deficiency or improvement of a technical or nontechnical nature concerning subsystems, materials, processes, or procedures which impact on current operational systems or systems being acquired.

(2) The corporate memory or lessons learned file provides a method of sharing lessons learned through experience in acquisition and deployment of existing systems. The intent is to provide a focal point where program managers can obtain feedback on the results of previous design and acquisition management decisions and practices. The AFLC lessons are classified into two basic categories, technical and nontechnical (management).

(a) Technical lessons learned pertain to the design features of a system/subsystem/equipment which influence reliability, maintainability, availability, and support cost. This includes supporting operational or test software.

(b) Nontechnical lessons learned deal with program management and logistics

support planning influences such as procedural deficiencies/improvements, time-phasing of program office/integrated logistics support office (PO/ILSO) actions, quality assurance, and other logistics support considerations.

(3) AFOTTEC test directors are also charged with reporting on lessons learned during the planning and execution of OT&E programs. After screening and substantiation, these reports are placed on file in the OT&E data bank maintained by AFOTTEC for use by all MAJCOMs.

(4) Other sources of lessons learned may be found in system program offices, operating commands, and other services. Examination of the files may aid in identifying key readiness and cost drivers for investigation during T&E. (Sources: AFR 55-43 and AFLCP/AFSCP 800-34.)

A5-10. Military/DOD Handbooks and Standards. Several military/DOD handbooks and standards describe the availability, reliability, and maintainability concepts, parameters and various evaluation techniques. Descriptions of those most pertinent to the suitability evaluation follow:

a. MIL-HDBK 108, Interim Quality Control and Reliability - Sampling Procedures and Tables for Life and Reliability Testing. This handbook describes general and specific procedures, plus applications of sampling plans where life tests are terminated at a preassigned number of failures or a preassigned time. It also describes sequential life test sampling plans and provides operating characteristic curves which can be used in OT&E effort as well as research and development.

b. MIL-HDBK 189, Reliability Growth Management. This handbook provides the concepts and principles of reliability growth, advantages of managing reliability growth, and guidelines and procedures to be used in managing reliability growth. It also contains descriptions of commonly used reliability growth models.

c. MIL-HDBK 472, Maintainability Prediction. This handbook provides techniques to predict the maintainability of a system in quantitative terms. It is intended for application early in the acquisition cycle to highlight areas of poor maintainability design for product improvement, modification, or a change in design. The handbook contains a series of prediction procedures for using comparability data to predict the maintainability of new systems.

d. DOD 3235.1-H, Test and Evaluation of System Reliability, Availability, and Maintainability—a Primer. This handbook

presents concepts and techniques for designing test plans to verify that previously established system suitability requirements have been achieved. It provides various statistical concepts and techniques required to thoroughly understand the relationships among test design, assessment, and projection of population characteristics.

e. MIL-STD 105, Sampling Procedures and Table for Inspection by Attributes. This standard provides procedures and tables for planning and conducting inspections, whereby either the unit or product is classified simply as defective or nondefective or the number of defects in the unit or product is counted with respect to a given requirement or set of requirements.

f. MIL-STD 470, Maintainability Program Requirements. This standard establishes the requirements for a maintainability program and provides guidelines for the preparation of a maintainability plan in the development of a system.

g. MIL-STD 471, Maintainability Demonstration. This standard provides procedures and test methods for quantitative and qualitative maintainability requirements. It also provides for qualitative assessment of other elements of integrated logistics support such as technical orders, personnel, support equipment, provisioning, and maintenance concepts.

h. MIL-STD 490, Specification Practices. This standard covers the preparation of specifications, including their format and content. It may be useful to understand the application of contract specifications to the system being evaluated.

i. MIL-STD 721, Definitions of Effectiveness Terms for Reliability, Maintainability, Human Factors, and Safety. This standard provides precise, clear definitions to reduce the possibility of conflict, duplication, or incorrect interpretation of the meaning of a term. It is an authority for standardization, not an all-inclusive list of R&M terms.

j. MIL-STD 756, Reliability Modeling and Prediction. This standard establishes uniform procedures for predicting the quantitative reliability of aircraft, missiles, satellites, electronic equipment, and subdivisions of them throughout the development phases to reveal design weaknesses and to form a basis for apportionment of reliability requirements to the various subdivisions of the product.

k. MIL-STD 781, Reliability Testing for Engineering Development, Qualification, and Production. This standard covers reliability qualification and production acceptance tests. It is used to standardize

reliability tests for more direct comparison of test results. The equipment tests outlined in this standard do not replace specified functional or environmental tests.

l. MIL-STD 785, Reliability Program for Systems and Equipment Development and Production. This standard establishes uniform criteria for a reliability program and provides guidelines for preparing and implementing a reliability program plan, including content and format.

m. MIL-STD 1388, Logistics Support Analysis. This standard provides task descriptions for the performance of logistics support analysis. It contains an overall list of logistics support analysis tasks from which applicable tasks may be selected and tailored to a specific analysis program and includes the rationale for selecting and tailoring task descriptions.

n. MIL-STD 1543, Reliability Program Requirements for Space and Missile Systems. This standard establishes uniform reliability program practices and procedures for use during design, development, fabrication, test, and operation of space and missile systems.

o. MIL-STD 1635 (EC), Reliability Growth Testing. This standard covers the requirements and procedures for reliability development (growth) tests conducted during the hardware development phase. These tests provide engineering information on the failure modes and mechanisms of a test item under natural and induced environmental conditions of military operations. Reliability improvements (growth) will result when failure modes and mechanisms are identified and their recurrence prevented through implementation of corrective action.

p. MIL-STD 2068(AS), Reliability Development Tests. This standard establishes requirements and procedures for a reliability development test to implement the MIL-STD 785 requirement for such a test.

It is applicable to Navel Air Systems Command.

q. MIL-STD 2074 (AS), Failure Classification for Reliability Testing. This standard establishes criteria for classification of failures occurring during reliability test. Note: Appendix B of MIL-STD 2068 (AS) contains equivalent criteria for reliability growth assessments.

r. DOD-STD 2167A, Defense System Software Development. This standard establishes uniform requirements for software development that are applicable throughout the system life cycle. It provides a basis for government insight into a contractor's software development, testing, and evaluation efforts. In addition, it provides a means for establishing, evaluating, and maintaining quality in software and associated documentation.

s. DOD-STD 2168, Defense System Software Quality Program. This standard contains requirements for the development, documentation, and implementation of a software quality program to be applied during the acquisition, development, and support of software systems. This program includes planning for and conducting evaluations of the quality of software, associated documentation, and related activities and planning for and conducting the follow-up activities necessary to ensure timely and effective resolution of problems. This incorporates the applicable requirements of MIL-STD 1520 and MIL-STD 1535.

t. DOD-STD 5200.28, Department of Defense Trusted Computer System Evaluation Criteria. This standard defines evaluation criteria to classify systems into four broad hierarchical divisions of enhanced security protection. It provides a basis for the evaluation of effectiveness of security controls built into automatic data processing system products.

DEFINITIONS

This attachment provides definitions of terms most commonly used during OT&E. As a general rule, the definitions provided are currently in use in the Air Force and have been extracted verbatim from other directives (DODIs/DODDs, AFRs, MIL-STDs, etc.). A limited number of terms are unique to a test program for which specific definitions were developed. (See chapter 13 for diagnostics definitions.)

Abort. Failure to accomplish a mission for any reason other than enemy action. It may occur at any point from initiation of operation to destination. (JCS Pub 1)

Acceptance Tests. Those tests performed to demonstrate that a specific lot of articles has been manufactured to specifications. (AFR 80-14)

Acquisition. The procurement of ownership of real property by any means exclusive of lease agreements. The process consists of planning, designing, producing, and distributing a weapon system/equipment. Acquisition in this sense includes the concept exploration, validation, FSD production, and deployment/operational phases of the weapon systems/equipment projects. (DOD 7040.2)

Acquisition Cost. A term used within DOD to denote the aggregation of costs to develop, produce, and deploy a weapon system in its operational environment. It commences with the conceptual phase and is completed when the last production unit is delivered to the using command. It excludes all operational activities associated with the mission application of the acquired weapon system. (AFSCR 800-6)

Acquisition Process. Normally, this consists of discrete logical phases separated by major decision points, called milestones (DODD 5000.1). The phases span the life cycle of a weapon system and provide a means of progressively translating broadly stated mission needs into well-defined system-specific requirements.

a. Phase I, Concept Exploration and Definition. This phase begins with Milestone O, Concept Studies Approval. Its purpose is to explore various material alternatives to satisfying the documented mission need, define the most promising system concepts, develop supporting analyses/information for the Milestone I decision, and

develop a proposed acquisition strategy and initial program objectives for cost, schedule, and performance (DODI 5000.2).

b. Phase II, Demonstration and Validation. This phase begins with Milestone I, Concept Demonstration Approval. Its purpose is to prove technologies and processes critical to the most promising system concepts are understood and attainable, better define critical design characteristics, develop analyses/information to support a Milestone II decision, and establish a proposed development baseline (DODI 5000.2).

c. Phase III, Engineering and Manufacturing Development. This phase begins with Milestone II, Development Approval. Its purpose is to translate the preferred design approach into a stable system design, validate the manufacturing or production process, and demonstrate through testing, that system capabilities meet contract specification requirements and minimum acceptable operational performance requirements (DODI 5000.2).

d. Phase IV, Production and Deployment. This phase begins with Milestone III, Production Approval. Its purpose is to establish a stable, efficient production and support base, achieve an operational capability that satisfies the identified mission needs, and conduct follow-on operational and production verification testing (DODI 5000.2).

e. Phase V, Operations and Support. This phase begins with Milestone IV, Major Modification Approval (as required). Its purpose is to ensure fielded system continues to provide the capabilities required to meet the identified mission need and identify shortcomings or deficiencies that must be corrected (DODI 5000.2).

Air Force System Acquisition Review Council (AFSARC). The AFSARC is an advisory council established by and functioning for the Secretary of the Air Force (SAF) which provides a forum for the review of major acquisition programs and Air Force designated acquisition programs (AFDAP). Other programs may receive AFSARC reviews as determined by the SAF. (AFR 800-2)

Air Force Weapon System Improvement Group (AFWSIG). Provides the DCS for Logistics and Engineering (HQ USAF/LE) with an OT&E suitability assessment in support of LE inputs to the AFSARC.

Assessment. Provides information about a system's capabilities without assigning ratings. This term applies when user requirements are not available or are not appropriate for the phase of development. Information is needed to support the user or decision-making process. Quantitative or qualitative test criteria will generally not be available to support these objectives.

Automatic Test Equipment (ATE) Program. The actions taken to ascertain to what extent depots may use automatic electronic test equipment in promoting the efficient and economical maintenance and analysis of weapon system equipment. The term also encompasses (1) the necessary research and development actions, (2) control of acquisition and application, and (3) controls to ensure that adequate consideration is given to future system design of programmed weapon systems and/or subsystems for ultimate compatibility with programmed or existing depot ATE. (AFLCR 66-26)

Availability. A measure of the degree to which an item is in the operable and committable state when the mission is called for at any random point in time. Availability is dependent on reliability, maintainability, and logistics supportability. (AFR 800-18)

a. Availability (Armament, Munitions). The percentage of assigned munitions capable of performing the specified missions at any random point in time. (AFR 800-18)

b. Availability (Intercontinental Ballistic Missile (ICBM)). The percentage of a missile force capable of commitment to the launch sequence at any random point in time. (AFR 800-18)

Before Flight Abort. An attempted sortie that fails to become airborne because of a failure. The criteria used will be those applied by the predominant using command.

Bench Check. A workshop check for the condition, completeness, or working order of a piece of equipment. (AFM 67-1)

Bench Check Serviceable Rate. The percentage of items removed from an end item because of a suspected failure for which the failure was not confirmed during bench check using available skills, test equipment, and technical data.

Cannibalization. The authorized removal of specific components from one item of Air Force property for installation on another item of Air Force property to meet priority

requirements with the obligation of replacing the removed components. (AFM 67-1)

Cannibalization Rate. A measure of on-equipment cannibalization actions (removals performed to keep an end item in operationally ready condition. The rate may be expressed as average cannibalization per sortie, per 1,000 flying hours, or other life units.

Captive-Carry Reliability. The probability that a weapon will remain failure free while properly loaded on the host aircraft. When the weapon is commanded to launch, it is expected to perform a successful launch. (AFR 800-18)

Captive-Carry Time. The cumulative flying time accrued by a missile or other ordnance end item while attached to a bomb rack or missile launcher on an aircraft from the beginning of the first flight to the moment the missile or ordnance item is launched.

Compatibility. The capability of two or more items/systems to exist or function as elements of a larger system or environment without mutual interference. (AFR 80-14)

Computer Resources Life Cycle Management Plan (CRLCMP). This plan provides the details for planning and implementing the technical and managerial responsibilities and supporting elements required to accomplish software development and life cycle support. MIL-STD 2167 requires the development of the CRLCMP.

Contractor Logistics Support. The collection of logistics support activities provided under contract to a using command.

Corrective Maintenance. All actions performed as a result of a failure to restore an item to a specified condition. Corrective maintenance can include any or all of the following steps: localization, isolation, disassembly, interchange, reassembly, alignment, and checkout. (MIL-STD 721C)

Critical Design Review. A formal review conducted on each configuration item before fabrication/production design release to ensure that the detail design solutions, as reflected in the draft part II product specification and engineering drawings, satisfy performance requirements established by the part I development specification.

Critical Failure. A failure or combination of failures (hardware or software) that pre-

vent an item from performing its specified missions.

Critical Issues. Those aspects of a system's capability, either operational, technical, or other, that must be questioned before a system's overall worth can be estimated, and that are of primary importance to the decision authority in reaching a decision to allow the system to advance into the next acquisition phase. (DODD 5000.3)

Defence Acquisition Board (DAB). An advisory council established by and functioning for the Secretary of Defense (SECDEF) to apprise the SECDEF of the program status and readiness of a major defense system prior to proceeding to the next phase in the acquisition process. (DODI 5000.2 and AFR 800-2)

Depot-Level Maintenance. Maintenance performed on materiel requiring major overhaul or a complete rebuild of parts, assemblies, subassemblies, and end items, including the manufacture of parts, modification, testing, and reclamation as required. Depot maintenance supports lower levels of maintenance by (1) providing technical assistance and performing that maintenance beyond their responsibility or capability, (2) providing stocks of serviceable equipment, and (3) using more extensive facilities for repair than are available in organizational- or field-level maintenance activities. (AFM 67-1)

Depot-Level Maintenance Support. Maintenance and modification support accomplished or provided by Air Force Logistics Command (AFLC). It includes (1) organizational- and intermediate-level maintenance or modification work which cannot be economically accomplished within the using command's total resources and is so certified by the using command headquarters, and (2) depot-level maintenance or modification work which, because of the complexity of the job, requires special skills, tools, equipment, or facilities available only at a depot-level facility. (AFR 66-1)

Depot Maintenance Facility. This is a military or contractor facility that performs depot-level maintenance modification of aircraft/missiles. (AFR 66-3)

Design Deficiency. Any material condition which is in conformance with contractual requirements, yet limits or precludes use of material in the intended manner and/or for the intended purpose. Those deficiencies

cannot be corrected except through a design change. (DODD 7700.12)

Design to Cost. A concept that directs action during the design phase of weapon system to establish cost as a key parameter together with schedule and system performance criteria. System design and development are continuously evaluated against cost requirements with the same rigor as applied to technical requirements. (AFR 173-1)

Development Test and Evaluation (DT&E). DT&E is that T&E conducted to assist the engineering design and development process and to verify attainment of technical performance specifications and objectives. DT&E is normally accomplished or managed by the DOD component's systems, hardware/software integration, related software, and prototype or full-scale engineering development models of the system. T&E of compatibility and interoperability with existing or planned equipment and systems are also included. (DODD 5000.3)

Dormant Reliability. The probability that an item will remain failure free for a specified period of time in a nonoperating mode under stated environmental conditions. When the system is removed from the dormant stage, it is expected to perform within specifications. (AFR 800-18)

Downtime Per Sortie. For a specified period of time, the total time the system is not mission capable, maintenance (NMCN), scheduled or unscheduled; not mission capable, supply (NMCS); or not mission capable, both (NMCB), scheduled or unscheduled; in clock hours divided by the number of sorties. (AFR 800-18)

End Item. A final combination of end products, component parts, and/or materials ready for its intended use, e.g., aircraft, ships, tanks, mobile machine ship. (AFR 400-3)

Engineering Change Proposal (ECP). The document for proposing any design change to an item, facility, part, and so forth, delivered or to be delivered, which will require revision to the contract specifications or engineering drawings, or the documents referenced that are approved or authorized for applicable items under government contracts. (AFR 400-3)

Evaluation. The review and analysis of qualitative and/or quantitative data obtained

from design review, hardware inspection, testing, and/or operational usage of equipment. (AFR 80-14)

Exploratory and Advanced Development. Exploratory development includes all efforts directed to solving specific military problems short of major development projects. Advanced development includes all projects that have moved into the development of hardware for experimental or functional test. (AFR 800-18)

Failure Rate. The total number of failures within an item population divided by the total number of life units expended by that population, during a particular measurement interval under stated condition. (MIL-STD 721C)

Follow-on Operational Test and Evaluation (FOT&E). That test and evaluation conducted after IOT&E to continue and refine the estimates made during the IOT&E, to evaluate changes, and to reevaluate the system to ensure that it continues to meet operational needs and retain its effectiveness in a new environment or against a new threat. (AF 80-14)

Foreign Object Damage (FOD). Damage to or malfunction of an aircraft, missile, or drone caused by an object that is alien to an area or system, being ingested by, or lodged in a mechanism. (AFR 66-33)

Functional Configuration Audit (FCA). The formal examination of functional test data for a configuration item, prior to acceptance, to verify that the item has achieved specified performance. (AFR 65-3)

Goal. Goals are levels of performance (established by the user) above that required, which, if achieved, will provide additional operational capability. Goals are not normally addressed by HQ AFOTTEC whose primary concern is requirement. (AFR 57-1)

Government-Furnished Equipment (GFE). Items in the possession of or acquired directly by the government and delivered to or otherwise made available to the contractor. (AFR 70-9)

Government Industry Data Exchange Program (GIDEP). An Army-, Navy-, Air Force-, and NASA-sponsored program for the exchange of data among government agencies and industry to reduce the costs of investigative efforts on parts and materials. (AFR

800-18)

Ground Abort. Any aircraft confirmed by maintenance as operational and ready for flight that fails to launch for any system malfunction/failure/reject.

How-Malfunctioned Code. A three-digit number used to provide a description of the trouble on or in the equipment or component. (Appropriate system work unit code (WUC manual.)

Human Engineering. The application of knowledge of man's capabilities and limitations to the planning, design, development, and testing of aerospace systems, equipment, and facilities to achieve optimum personnel safety, comfort, and effectiveness compatible with systems requirements. (AFM 11-1)

Human Factors. Those factors that contribute to the optimization of a system by integrating the human performance necessary to operate, maintain, support, and control the system in its intended operational environment. (AFR 80-14)

Implementing Command. The command responsible for managing the program or development and acquisition of the system, subsystem, or item of equipment. (AFR 800-18)

In-Flight Abort. A failure of an airborne aircraft so that it cannot effectively accomplish its primary or alternate scheduled mission because of a reported malfunction.

Inherent R&M Value. A measure of reliability or maintainability that includes only the effects of an item design and its application and assumes an ideal operation and support environment. (MIL-STD 721C)

Initial Operational Capability (IOC). The first attainment of the capability to employ effectively a weapon, item of equipment, or system of approved specific characteristics, and which is manned or operated by an adequately trained, equipped, and supported military/unit or force. (JCS Pub 1)

Initial Operational Test and Evaluation (IOT&E). OT&E conducted prior to the first major production decision. (AFR 80-14)

Initial Spares Support List (ISSL). A list of spares and repair parts and quantities required for organizational and field maintenance initial support of an end item for a

given period of time. Quantities established /for ISSL/ will be equal to initial base stock-age objective. (AFR 400-3)

In-Process Review (IPR). A review of a material development project conducted at critical points in the development cycle for the purpose of evaluating the status of the project, accomplishing effective coordination, and facilitating proper and timely decisions bearing on the future course of the project. (AFR 800-8)

Integrated Diagnostics. The process of efficiently utilizing the most effective combination of a system's automated, semiautomated, and manual diagnostics resources in a total system approach both during the mission, and subsequently, at each successive maintenance level.

Integrated Logistics Support (ILS). A composite of all support necessary to ensure effective, economical support of a system throughout its life cycle. (AFR 800-8)

Intermediate-Level Maintenance. Maintenance that is normally the responsibility of, and performed by, designated maintenance activities for direct support of using organizations. Its phrases normally consist of calibrating, repairing, or replacing damaged or unserviceable parts, components, or assemblies; modification of material, emergency manufacturing of unavailable parts; and providing technical assistance to using organizations. Intermediate maintenance is normally accomplished by the using commands in fixed or mobile shops. (AFR 66-1 and AFM 67-1)

Interoperability. The ability of systems, units, or forces to provide service to, and accept services from, other systems, units, or forces for their mutual effectiveness. (AFR 80-14)

Latent Defect. A flaw or other imperfection in an article discovered after delivery to the government. Such defects are inherent weaknesses normally not detected by examination or routine test but present at time of manufacture. (AFM 67-1)

Launch Availability. The probability that a launch vehicle system will be ready for launch in any preselected launch window. (AFR 800-18)

Launch and Flight Reliability (LFR). The probability of a missile system that is

available for commitment to the launch sequence, responding to a valid launch command, and successfully completing the launch and flight with detonation of a given war-head within accuracy requirements. (AFR 800-18)

Level of Repair Analysis. A term assigned to a technique which establishes (1) whether an item should be repaired; (2) at what maintenance level, i.e., organizational, intermediate, or depot; or (3) if the item should be discarded. (AFP 800-7)

Levels of Protection. The degree of preservation, packaging, and packing required to prevent deterioration or damage to supplies and equipment because of the hazards to which they may be subjected during shipment and storage. (MIL-STD 129C)

Life Cycle Cost. The total cost of an item or system over its full life. It includes the cost of development, production, ownership (operation, maintenance, support, etc.), and where applicable, disposal. (AFR 800-11)

Line-Replaceable Unit (LRU):

a. An item that is normally removed and replaced as a single unit to correct a deficiency or malfunction on a weapon or support system and item of equipment. Such items have a distinctive stock number for which repairs may be locally authorized to support the removal and replacement action. These items are repair cycle assets subject to/due in from maintenance (DIFM) controls (TO 00-20-3) and may be disassembled into separate components during shop processing.

b. The components, shop-replaceable units (SRU), may also be repair cycle assets subject to DIFM controls if they are processed separately and spares are locally authorized and maintained to support intermediate-level repair of the LRU. (AFM 400-1)

Logistics:

a. The science of planning and carrying out the movement and maintenance of forces. In its most comprehensive sense, those aspects of military operations that deal with design and development, acquisition, storage, movement, distribution, maintenance, evacuation, and disposition of material; movement, evacuation, and hospitalization of personnel; acquisition or construction, maintenance, operation, and disposition of facilities; and acquisition or furnishing of services. (JCS Pub 1 and AFP 800-7)

b. The functional fields of military operations concerned with materiel requirements;

production planning and scheduling; acquisition, inventory management, storage, maintenance, distribution and disposal of materiel, supplies, tools, and equipment; transportation, telecommunications, petroleum, and other logistical services; supply cataloging, standardization, and quality control; commercial and industrial activities and facilities including industrial equipment; and vulnerability of resources to attack damage. (DODD 5000.8)

c. The phase of military operations involving procurement, delivery, storage, shipment, and scheduling of military supplies, including personnel. (AFLCR 72-2)

d. The determination of initial and follow-on requirements and the procurement, storage, transportation, distribution, maintenance, quality control, and disposal of material and related services for the military forces. (AFLCR 400-15)

Logistics Assessment. An evaluation of the logistics support required to support particular military operations in a theater of operations, country, or area.

Logistics Assessment Review (LAR). Conducted by HQ USAF/LE before key acquisition milestones, i.e., AFSARC reviews, OSD program reviews, and DAB reviews. HQ USAF/LE reviews logistics data to ensure that logistics areas are given adequate consideration. The developing, supporting, and operating commands provide information to the assessment. AFOTEC provides the operational suitability assessment. (AFOTECP 500-3)

Logistics Concept. A plan of how to build up or support a military force, i.e., to provide supplies, equipment, transportation, maintenance, etc. (AFM 67-1)

Logistics Planning. The determination of the logistics posture to be established for support of a weapon/support system program based on prescribed mission objectives to be achieved. (AFM 11-1, AFP 800-7)

Logistics Process. A task or group of interrelated logistics tasks designed to produce a desired result independent of the organizational arrangement employed. (AFM 400-2)

Logistics Resources. The support personnel and material required by an item to ensure its mission performance. It includes such things as tools, test equipment, repair parts, facilities, technical manual, and ad-

ministrative supply procedures necessary to ensure the availability of these resources when needed. (AFP 800-7)

Logistics Support Analysis (LSA). A process by which the logistics support necessary for a new system/equipment is identified. It includes the determination and establishment of logistics support design constraints, consideration of those constraints in the design of the "hardware" portion of the system, and analysis of design to validate the logistics support feasibility of the design and identify and document the logistics support resources which must be provided, as a part of the system/equipment, to the operating forces. Analytical techniques used to determine limited aspects of logistics support requirements are a part of the overall LSA process. (An example would be operational sequential diagramming used to determine operator tasks, task times, and skills.) (AFP 800-7 and MIL-STD 1388)

Logistics Support Costs. Costs associated with supporting an item, to include (when obtainable) costs of base labor, base materiel costs to replace condemnations, transportation and shipping costs for nonbase repairable items, technology repair center costs, and others when the cost is quantifiable and meaningful for effective analysis. (AFLCR 400-16)

Logistics Support Elements. Principal logistics elements that must be properly integrated to achieve economical and effective support of a system or equipment throughout its life cycle. The elements are R&M interface; maintenance planning; support equipment; facilities; training; technical data; personnel; supply support; packaging, handling, transportation, and storage; logistics support resource funds; logistics support management information; design interface; computer resources support; energy management; survivability; and ILS T&E. (AFR 800-8)

Logistics Supportability. How well the composite of support considerations necessary to achieve the effective and economical support of a system or equipment for its life cycle meets stated quantitative and qualitative requirements. This includes integrated logistics support and logistics-related O&S cost considerations. (AFR 80-14)

Logistics System. A group of related and sequential actions or documents required and/or used to accomplish one or more ele-

ments of the AFLC mission (AFR 23-2) or to provide support in the accomplishment of the mission. This includes operational and management functions. The term "logistics system" encompasses such terms as data system, automated data system, management system, business system, and similar terms. In general, any group of actions for processes performed repetitively as differentiated from nonrecurring special projects is considered a logistics system or subsystem. (AFLCM 400-4)

Low-Rate Initial Production (LRIP). The production of a system in limited quantity to be used in OT&E for verification of production engineering and design maturity and to establish a production base.

Maintainability. The measure of the ability of an item to be retained in or restored to specified condition when maintenance is performed by personnel having specified skill levels, using prescribed procedures and resources, at each prescribed level of maintenance and repair. Also reference MIL-STD 721 for the general definition of maintainability. (AFR 800-18)

Maintenance. All actions necessary for retaining material in or restoring it to a serviceable condition. Maintenance includes servicing, repair, modification, modernization, overhauls, inspection, condition determination, corrosion control, and initial provisioning of support items. (AFR 66-14)

Maintenance Downtime Per Sortie. For a specified period of time, the total time the system is NMCM and NMCB, scheduled, in clock hours, divided by the number of sorties. (AFR 800-18)

Maintenance Engineering. The developing of maintenance concept, criteria, and technical requirements--during the conceptual and definition phases--to be applied and maintained in the operational phase, to ensure timely, adequate, and economic maintenance support of systems and equipment. (AFR 66-1)

Maintenance Man-Hours Per Life Unit (MMH/LU). The base-level, direct maintenance man-hours required to support a system divided by the number of life units (e.g., MMH/S, MMH/FH). This includes direct maintenance man-hours identified by the Standard Reporting Designator of the weapon system and its installed or removed equipment. (AFR 800-18)

Maintenance Personnel Per Operational Unit. (User of this term needs to define the operational unit.) The number of maintenance personnel that will be required to support an operational unit (excluding depot-level and other manpower that is excluded from maintenance planning factors by AFR 26-3) under specified operating and maintenance concept. (AFR 800-18)

Mature System. An operational system is considered mature when its R&M characteristics cease to improve significantly with continued use. System, subsystems, and components all mature at various rates for varying lengths of time. Unless otherwise specified, a system will be considered to have mature R&M characteristics 2 years after the initial operational capability date. (AFR 800-18)

Mean Downtime (MDT). The average elapsed time between loss of mission-capable status and restoration of the system to mission-capable status. (AFR 800-18)

Mean Man-Hours To Repair. The total corrective base-level man-hours divided by the total of equipment corrective maintenance events for a given period of time. (AFR 800-18)

Mean Mission Duration (MMD). The average interval of time over which a space system is expected to operate without mission failure. (AFR 800-18)

Mean Time Between Critical Failures (MTBCF). The average time between failure of essential system functions. (AFR 800-18)

Mean Time Between Demands (MTBD). A measure of the system reliability parameter related to demand for logistics support: the total number of system life units (e.g., flying hours, sorties, etc.) divided by the total number of item demands on the supply system during a stated period of time. Demands are defined in AFLCR 57-4, Recoverable Consumption Item Requirements System. (AFR 800-18 and MIL-STD 721C)

Mean Time Between Downing Events. A measure of the system reliability parameter related to availability and readiness. The total number of system life units divided by the total number of events in which the system becomes unavailable to initiate its mission(s) during a stated period of time. (MIL-STD 721C)

Mean Time Between Failures (MTBF). (A contract term only.) A basic measure of reliability for repairable items. The mean number of life units during which all parts of the item perform within their specified limits during a particular measurement interval under stated conditions. (MIL-STD 721C)

Mean Time Between Maintenance (MTBM). The total life units (for example, operating hours, flight hours, rounds) divided by the total number of maintenance (base-level) events for a specific period of time. (AFR 800-18)

a. Mean Time Between Maintenance (Induced). The average time between the on-equipment corrective events associated with malfunctions resulting from other than internal design and manufacturing characteristics, for example, improper maintenance, operator error, foreign object damage, and failures caused by malfunction of associated equipment. (AFR 800-18)

b. Mean Time Between Maintenance (Inherent). The average time between the on-equipment corrective events associated with malfunctions resulting from internal design and manufacturing characteristics. (AFR 800-18)

c. Mean Time Between Maintenance (No Defect). The average time between the on-equipment corrective events associated with equipment which have no confirmed malfunction, such as removals which subsequently bench check satisfactory. (AFR 800-18)

d. Mean Time Between Maintenance (Preventive). The average time between maintenance events including removals, replacement, or reinstallation associated with scheduled maintenance or time changes. (AFR 800-18)

Mean Time Between Removal (MTBR). A measure of the system reliability parameter related to demand for logistics support. The total number of system life units divided by the total number of items removed from that system during a stated period of time. This term is defined to exclude removals performed to facilitate other maintenance and removals for TCTOs (product improvement). (AFR 800-18, MIL-STD 721C)

Mean Time To Failure (MTTF). A basic measure of reliability for nonrepairable items. The total number of life units of an item divided by the total number of failures within that population during a particular measurement interval under stated condi-

tions. (MIL-STD 721C)

Mean Time To Repair (MTTR). (A contract term only.) A basic measure of maintainability: the sum of corrective maintenance times at any specific level of repair divided by the total number of failures within an item repaired at that level during a particular interval under stated conditions. (MIL-STD 721C)

Mean Time To Restore System (MTTRS). A measure of the system maintainability parameter related to availability and readiness. The total corrective maintenance time associated with downing events divided by the total number of downing events during a stated period of time. (Excludes time for off-system maintenance and repair of detached components.) (MIL-STD 721C)

Mean Time To Service (MTTS). A measure of an on-system maintainability characteristic related to servicing that is calculated by dividing the total scheduled crew/operator/driver servicing time by the number of times the item was serviced. (MIL-STD 721C)

Mission Reliability. A measure of the ability of a system to complete its planned mission or function. (AFR 800-18)

Mission Time To Restore Functions (MTTRF). A measure of mission maintainability: the total corrective critical failure maintenance time, divided by the total number of critical failures, during the course of a specified mission profile. (MIL-STD 721C)

Network Report Level Analysis (NRLA). NRLA is the preferred means of performing RLA. It solves the RLA problem for LRUs and SRUs. It solves the problems of failure mode, recognizing that an LRU may fail in any of several different ways. It treats its individual failure modes as part of the overall problem. It treats the problem of shared SE successfully.

Not Mission Capable (NMC). A status code meaning that the system or equipment cannot perform any of its primary missions. It can be followed by a reason code meaning maintenance (M), supply (S), or both (B). (AFR 66-14)

Not Repairable This Station (NRTS). A status condition determined during shop processing of an item used to indicate that the item cannot be repaired at base level

because of lack of authorization, technical skills, parts, facilities, manpower, or any other causes. (TO 00-20-1)

Off-Equipment Maintenance. In-shop maintenance actions performed on removed components, except complete aircraft engines. (AFR 800-18)

OMNIVORE/MICRO-OMNIVORE. A data retrieval and analysis system. (AFOTECP 171-202)

On-Condition Maintenance. Application of inspection and testing procedures and techniques without removal or disassembly that allows the condition of the equipment to dictate the need for maintenance or the extent of repair/overhaul required to restore serviceability. (AFR 66-38)

On-Equipment Maintenance. Maintenance actions accomplished on a complete end item such as aircraft, trainers, support equipment, CEM equipment, complete round munitions, and uninstalled aircraft engines. (AFR 800-18)

On-Launcher Reliability. The percentage of ready missiles which will successfully complete the countdown and leave the launcher within the required time limits. (DODD 3100.1)

Operating Command. The command or agency primarily responsible for the operational employment of a system, subsystem, or item of equipment; it is also a participating command. (AFR 800-18)

Operational Assessment (OA). The operational test agency's independent appraisal of the status of operational requirements and IOT&E readiness and the progress, from an operational perspective, of a system's development.

Operational Effectiveness. The overall degree of mission accomplishment of a system used by representative personnel in the context of the organization, doctrine, tactics, threat (including countermeasures and nuclear threats), and environment in the planned or operational employment of the system. (DODD 5000.3)

Operational Reliability and Maintainability. A measure of reliability, maintainability, or availability expressed in operational terms that includes the combined effects of item design, quality, installation, environ-

ment, operation, maintenance, repair, funding, and management policy. (AFR 800-18)

Operational Suitability. The degree to which a system can be satisfactorily placed in field use with consideration being given to availability, compatibility, transportability, interoperability, reliability, wartime usage rates, maintainability, safety, human factors, manpower supportability, logistic supportability, documentation, and training requirements. (DODI 5000.2)

Operational Test and Evaluation (OT&E). OT&E is conducted in as realistic conditions as possible throughout the system life cycle. It is done to estimate (or to refine estimates of) a system's operational effectiveness and operational suitability, to identify any operational deficiencies, and to identify the need for any modifications. (AFR 80-14)

Operational Utility Evaluations (OUE). OUEs are conducted (1) to validate a concept and (2) to expand the mission of an existing (perhaps modified) weapon system to a substantially different role or mission. OUEs pertain to those operational tests clearly outside the scope of existing tests (i.e., DT&Es, IOT&Es, QOT&Es, and FOT&Es). An OUE may be conducted before Milestone I at which time the focus is on providing information necessary to support or validate concept selection (for example, type of system to best fill the operational reconnaissance needs of theater commanders such as aircraft vis-a-vis remotely piloted vehicle vis-a-vis satellite systems). Conversely, OUEs may also investigate the feasibility of expanding the operational mission of an existing/modified system to a new mission or scenario (for example, modifying an air-to-ground antiarmor missile so it can be employed in the airfield attack scenario against reverted aircraft). OUEs will be HQ USAF directed and AFOTEC or MAJCOM conducted and will be specifically limited in time and scope. OUEs will normally be accomplished with RDT&E (3600) funds; however, in some instances, OUEs may be more appropriately funded through the MAJCOM account. If there is insufficient time for normal funding in the PPBS schedule, funding will be provided by HQ USAF concurrently with the direction to conduct an OUE.

Optimum Repair Level Analysis (ORLA). (A subset of repair level analysis (RLA).) (See AFSCR/AFLCR 800-28, Repair Level Analysis Program.) A trade study conducted by a contractor as part of the system/equip-

ment engineering analysis process. ORLA provides contractors and prospective contractors with a basis on which to evolve an "optimum" approach to repair recommendations concurrent with the design and development process. (AFLCM/AFSCM 800-4 and AFLCR 66-26)

Orbital Availability. The percentage of on-orbit time that a space system is capable of performing the specified missions. (AFR 800-18)

Organizational-Level Maintenance. Maintenance that is the responsibility of and performed by a using organization on its assigned equipment. Organizational maintenance normally consists of inspecting, servicing, lubricating, adjusting, and replacing parts, minor assemblies, and subassemblies. (AFM 400-1)

Partially Mission Capable (PMC). The percentage of possessed time that a system is capable of performing at least one but not all of its assigned wartime missions. PMC may be subdivided into partially mission capable, maintenance (PMCM); partially mission capable, supply (PMCS); and partially mission capable, both (PMCB). (AFR 66-14)

Participating Command. A command or agency designated by HQ USAF to support and advise the program manager during the execution of a program. (AFR 800-14)

Pilot Production. A limited production run of a new system which has completed engineering development and for which the capability to mass produce the item for inventory needs to be demonstrated. (AFR 80-14)

Possessed Hours. The total hours in a given period that assigned equipment is under the operational control of the designated responsible organization. (AFR 800-18)

Program Element Monitor (PEM). The individual in the Air Staff designated to exercise overall monitorship over a program element. (AFM 11-1)

Prototype. First full-scale functional form of a new system on which the design of subsequent production items is patterned. (AFR 80-14)

Qualification Tests. Those tests that verify the design and manufacturing process and

thus provide a baseline for subsequent acceptance tests. (AFR 80-14)

Quick Turnaround Time. The clock hours required to prepare an aircraft for immediate relaunch after termination of a sortie. (AFR 800-18)

Reliability. The probability that an item will perform its intended function for a specified interval under stated conditions.

a. Logistics Reliability. A measure of a system's capability to operate as planned under the defined operational and support concepts using specified logistics resources (for example, spares or manpower). Logistics reliability recognizes the effect of all occurrences that place a demand on the logistics support system even when mission capability is unaffected. (AFR 800-18)

b. Mission Reliability. A measure of the ability of a system to complete its planned mission or function. (AFR 800-18)

Reliability Analysis Center (RAC). An official DOD contractor-operated center located at Rome Air Development Center (RADC) (code RBRAC) authorized to collect, analyze, and disseminate reliability data and information on microcircuits, solid state devices, nonelectronic parts and equipment, and systems. (AFR 800-18)

Reliability-Centered Maintenance Program (RCMP). A failure modes and effects analysis technique for significant aircraft and engine structures, assemblies, and items. It used a decision logic procedure based on the Airlines/Manufacturers' Maintenance Planning Document, MSG-2. This structured approach to maintenance requirements analysis identifies minimum essential requirements consistent with safety and readiness. (AFR 66-14)

R&M Engineering. That set of design, development, and manufacturing tasks by which R&M requirements are achieved. (AFR 800-18)

Repair-Level Analysis (RLA). The basic decisions about (1) repair versus throwaway and (2) the most desirable repair posture. (AFSCR/AFLCR 800-28)

Satellite Design Life. The expected successful orbital operating time before failure because of depletion of expendables. (AFR 800-18)

Secretarial Program Review (SPR). The

SPR is conducted to advise the Secretary of the Air Force and selected service staff on the research, development, and production aspects of major programs. It provides an in-depth evaluation and means for making decisions on all aspects of selected major systems. (AFOTTECR 500-3)

Service Report (SR). A report to supply AFR 80-14 test and evaluation data used in test reports on operational and logistics supportability of new systems or equipment prior to production decision and during follow-on testing. (TO 00-35D-54)

Shop-Replaceable Unit (SRU). A module for an LRU which can be removed from the LRU at an intermediate repair facility. (AFLCP 57-13)

Software Error. Any human action or omission in the software that results in the software containing a fault.

Software Failure. The inability of a system or system component to perform a required function within specified limits. A failure may result when a fault is encountered.

Software Fault. An accidental condition that causes a functional unit to fail to perform its intended function.

Software Maintainability. A measure of the effort required to locate and correct an error in the software, provide enhancements to existing software, or add new software to accomplish additional requirements when these maintenance activities are performed by personnel having specific skill levels, using prescribed procedures and resources.

Software Maturity. A measure of the software's progress in its evolution toward satisfaction of all documented user requirements.

Software Reliability. Software reliability is the probability that a software fault will not be encountered which could possibly cause a failure during a specified exposure period.

Software Supportability. A measure of the ability to modify deployed software in support of both static and dynamic mission requirements. Software supportability is a composite of (1) life cycle processes, (2) support resources, and (3) software maintainability.

Sortie Generation Rate. The number of sorties that can be flown per aircraft per day under specified operational and maintenance concepts. (AFR 800-13)

Support Equipment (SE). SE includes all equipment required to perform the support function except that which is an integral part of the mission equipment. It does not include any of the equipment required to perform mission operations functions. SE should be interpreted as including tools, test equipment, automatic test equipment (ATE) (when the ATE is accomplishing a support function); organizational, intermediate, and technical repair center SE; and related computer programs and software. (AFLCR 65-2)

Supporting Command. The command assigned responsibility for providing logistics support. It assumes program management responsibility from the implementing command; it may also be a participating command. (AFR 800-2)

System Program Office (SPO). The organization comprised of technical and business management and administrative personnel assigned full time to a system program director. The office may be augmented with additional personnel from participating organizations. (AFM 11-1)

Technical Order (TO). An Air Force publication that gives specific technical directives and information with respect to the inspection, storage, operation, modification, and maintenance of given Air Force items and equipment. (AFR 8-2)

Test and Evaluation (T&E). The term "test" denotes any project or program designed to obtain, verify, and provide data for the evaluation of research and development other than laboratory experiments; progress in accomplishing development objectives; performance and operational capability of systems, subsystems, and components; and equipment items. The term "evaluation" denotes the review and analysis of quantitative data produced during current or previous testing, data obtained from test conducted by other government agencies and contractors, from operation and commercial experience, or combinations thereof. (AFR 80-14 and AFM 11-1)

Test Planning Working Group (TPWG). When specified by AFSC program direction, this group is established by the program manager to provide a forum for test-related

subjects; to assist in establishing test objectives and evaluation baselines; to define organization, responsibilities, and relationships; to estimate costs and schedules; and to identify needed test resources. The TPWG normally includes representatives from the SPO, AFSC test agencies, contractor, AFOTTEC, and using and supporting MAJCOMs. (AFSC Sup 1 to AFR 80-14)

Test Support Group (TSG). Consists of representatives of HQ AFOTTEC directorates/detachments and staff offices with particular expertise required for a specific AFOTTEC-conducted/monitored OT&E. The TSG is chaired and directed by the AFOTTEC test manager and provides the assistance needed to budget for, plan, execute, evaluate, and report on a specific test program.

Threshold. Quantitative and qualitative minimum essential levels of performance or capability to permit mission accomplishment. These levels are based on (1) operational and maintenance concepts; (2) the threat estimate; (3) operationally significant performance levels contained in documents such as the PDM, PMD, or TEMP; and (4) the capabilities of existing systems (when valid comparison can be made). (AFR 55-43)

Time Compliance Technical Order (TCTO). Directives issued to provide instruction to Air Force activities for accomplishing "one-time" changes, modifications, or inspections of equipment or installation of new equipment. (AFLCR 171-91)

Transportability. The capability of material to be moved by towing, self-propulsion, or carrier via any means, such as railways, highways, waterways, pipelines, oceans, and airways. (JCS Pub 1)

Unscheduled Maintenance. Unpredicted maintenance that requires prompt attention to restore equipment serviceability. (AFSCR 66-7)

Uptime Ratio. The percent of possessed time that communications, electronics, and meteorological (CEM) systems are operational. (AFM 65-662)

Validation. The process by which the contractor tests TOs for technical accuracy and adequacy. This is accomplished by testing

the maintenance and operating instructions on the equipment/systems for which the TO was written. Validation is conducted at the contractor facility or at the operational site. (AFR 66-7)

War Readiness Spares Kit (WRSK). An air transportable package of spares and repair parts required to sustain planned wartime or contingency operations of a weapon system for a specified period of time pending resupply. WRSKs will include spares and repair parts for aircraft, vehicles, and other equipment, as appropriate. WRSKs are normally pre-positioned with the using unit. (AFM 11-1)

Wartime Usage Rates. Rates at which systems and their supporting subsystems, support equipment, and spares are consumed/used under war conditions.

Weapon System Reliability (WSR). The probability that a system will complete a specified mission, given that the system was initially capable of performing that mission. WSR is a measure of system reliability as it affects the mission but excludes factors such as probability of kill, circular error probable, and other measures of capability. (AFR 800-18)

Work Breakdown Structure (WBS). A product-oriented family tree division of hardware, software, services, and other work tasks which organizes, defines, and graphically displays the product to be produced as well as the work to be accomplished to achieve the specified product. (AFSCP AFLCP 173-5, DODD 7000.2)

Work-Unit Code (WUC). This code is a five-position code used to identify equipment being worked on or maintenance actions. WUCs which have a zero as the first digit are titled support general codes and will be found in all applicable -06 WUC manuals. Support general codes are used to identify maintenance actions such as aircraft ground handling, look phase of scheduled inspections ground safety, etc. WUCs used to identify items of the system (e.g., components, subsystems, etc.) may have as the first digit an alpha or numeric designator (other than zero) and are divided into broad categories. (AFM 65-110)

ABBREVIATIONS

The following abbreviations common to logistics assessments are currently accepted and in use in the Air Force. Abbreviations in common use are included even though they may not be used in this pamphlet.

A _a	achieved availability
act	aircraft
ACMS	advanced configuration management system
A&CO	assembly and checkout
AD	Armament Division (Air Force Systems Command)
ADP	automatic data processing
ADPE	automatic data processing equipment
ADS	automated data system
AFCC	Air Force Communications Command
AFDAP	Air Force Designated Acquisition Programs
AFEWC	Air Force Electronic Warfare Center
AFFTC	Air Force Flight Test Center
AFLC	Air Force Logistics Command
AFMSMT	Air Force maintenance and supply management team
AFOLDS	Air Force on-line data systems
AFOTEC	Air Force Operational Test and Evaluation Center
AFPG	Air Force planning guide
AFR	Air Force regulation
AFSARC	Air Force Systems Acquisition Review Council
AFSC	Air Force System Command
	Air Force specialty code
AFWSIG	Air Force Weapon Support Improvement Group
AGE	aerospace ground equipment
A _i	inherent availability
ALC	Air Logistics Center
ALD	Acquisition Logistics Division
ALDT	administrative and logistical delay time
AMTS	active man-hour task summary
ANOVA	analysis of variance
A _o	operational availability
ARM	availability, reliability, and maintainability
ARMS	ammunition reporting management system
ASD	Aeronautical Systems Division (Air Force Systems Command)
ATC	Air Training Command
	action taken code
ATE	automatic test equipment
AVISURS	aerospace vehicle and equipment inventory status and utilization reporting system
AVPR	air vehicle performance report
AWP	awaiting parts
BFA	before flight aborts
	BITE false alarm
BIT	built-in test
BITE	built-in test equipment
BLIS	base-level inquiry system
BMD	Ballistic Missile Division (equivalent to Space Division)

ABBREVIATIONS (continued)

C	delay time in corrective maintenance
CAP	combat air patrol
CAR	command assessment review
CBR	chemical, biological, and radiological
CCB	configuration control board
CCR	captive-carry reliability
CDEP	common data extraction program
CDR	critical design review
CDRL	contractor data requirements list
CEI	configuration end item contractor end item
CEM	communication-electronic-meteorology
CERT	combined environments reliability test
CFD	critical faults detected
CFE	contractor-furnished equipment
CMT	corrective maintenance time
CND	cannot duplicate
COMO	combat-oriented maintenance organization
COMSEC	communication security
CRISP	computer resources integrated support plan
CRWG	computer resources working group
CSAF	Chief of Staff, United States Air Force
CSAS	configuration status accounting system
CSRL	common strategic rotary launcher
CTAT	combat turnaround time
CTDCS	common test data collection system
DAB	Defense Acquisition Board
DAD	data description language
DAE	defense acquisition executive
DAR	Defense Acquisition Regulation (formerly ASPR)
DART	deficiency analysis review technique
DBA	data base administration
DBMS	data base management system
DCM	deputy commander for maintenance
DCP	decision coordinating paper
DDC	Defense Documentation Center
DDT&E	director, development test and evaluation
DEW	distant early warning
DID	data item description
DIDS	defense integrated data system
DIFM	due in from maintenance
DLE	deputy for logistics evaluation
DLSIE	Defense Logistics Studies Information Exchange
DMPA	deployment maintenance plan assessment
DOD	Department of Defense
DPI	data processing installation
DPM	development program manuals
DPML	deputy program manager for logistics
DR	dormant reliability
DSE	deputy for software evaluation
DT	downtime
DT&E	development test and evaluation

ABBREVIATIONS (continued)

DTIC	Defense Technical Information Center
DUEL	data update edit language
D&V	demonstration and validation
ECC	extended captive carry
ECMS	engine configuration management system
ECP	engineering change proposal
EDB	engineering data bank
EDSC	Engineering Data Service Center
EI	end item
EMI	electromagnetic interference
EOC	equipment operating cycle
EOD	explosive ordnance disposal
ESC	Electronic Security Command
ESD	Electronic Systems Division (Air Force Systems Command)
ESS	environmental stress screening
EW	electronic warfare
ETI	elapsed time indicator
FA	false alarm
FAD	force/activity designator
FAR	Federal Acquisition Regulation (formerly DAR)
FCA	functional configuration audit
FCF	functional check flight
FD	fault detection
FH	flight hours
FI	fault isolation
FIIN	federal item identification number
FIT	fault-isolation test
FMC	fully mission capable
FMEA	failure modes and effects analysis
FMECA	failure modes, effects, and criticality analysis
FOD	foreign object damage
FOL	forward operating location
FOT&E	follow-on operational test and evaluation
FRACAS	failure reporting and corrective action system
FRDB	failure rate data bank
FSC	federal supply classification
FSD	full-scale development
FT	free time
FTD	Foreign Technology Division
GFE	government-furnished equipment
GIDEP	government-industry data exchange program
GSE	ground support equipment
HRL	human resource laboratory
IAW	in accordance with
ICBM	intercontinental ballistic missile
IFA	in-flight aborts
ILS	integrated logistics support
ILSMT	integrated logistics support management team

ABBREVIATIONS (continued)

ILSP	integrated logistics support plan
IM	item manager
IMF	integrated maintenance facility
I/O	input/output
IOC	initial operational capability
IOT&E	initial operational test and evaluation
IPR	in-process review
IPS	integrated program summary
IROS	increase reliability of operational system
ISD	instructional systems development
ISP	integrated support plan
ISSL	initial spares support list
JMSNS	justification for major systems new start
JRMET	joint reliability and maintainability evaluation team
LA	launch availability
LAR	logistics assessment review
LCC	life cycle cost
LCOM	logistics composite model
LFR	launch and flight reliability
LG	Directorate of Logistics, AFOTEC
LGI	space surveillance and injunction systems division
LGM	aircraft systems division
LGOI	logistics operating instruction
LGW	weapons and ICBM systems division
LG4	logistics studies and analysis division
LG5	software analysis division
LOAP	list of applicable publications
LRB	logistics review board
LRU	line-replaceable unit
LSA	logistics support analysis
LSAR	logistics support analysis record
M	maintainability
MAC	Military Airlift Command
MA/FH	maintenance actions per flying hour
MAJCOM	major command
MC	mission capable
MCOTEA	Marine Corps Operational Test and Evaluation Agency
MCS	maintenance cost system
MCT	mean corrective time
MD	mission duration
MDC	maintenance data collection
MDCS	maintenance data collection system
MDR	maintenance data reporting
MDT	mean downtime
MEA	maintenance engineering analysis
MEAR	maintenance engineering analysis record
MEP	(Air Force) management engineering program
MESL	mission essential subsystem list
MFHBF	mean flying hours before failure
MHA	man-hour accounting

ABBREVIATIONS (continued)

MHR	mission hardware reliability
MILAP	maintenance information logically analyzed and presented
MIL-HDBK	military handbook
MIL-SPEC	military specification
MIL-STD	military standard
MIP	material improvement program
MIPR	military interdepartmental purchase request
Mmax C	maximum corrective maintenance time
MMD	mean mission duration
MMDT	mean maintenance downtime
MMH/CCH	maintenance man-hours per captive-carry hour
MMH/FH	maintenance man-hours per flying hour
MMH/LU	maintenance man-hours per life unit
MMH/M	maintenance man-hours per mission
MMH/MA	maintenance man-hours per maintenance action
MMH/OH	maintenance man-hours per operating hour
MMH/S	maintenance man-hours per sortie
MMICS	maintenance management information and control system
MMR	mean man-hours to repair
MNS	mission need statement
MOA	memorandum of agreement
MOB	main operating base
MOE	measure of effectiveness
MOOL	mean on-orbit lifetime
MOT&E	multinational operational test and evaluation
MR	material reporting
MRA&L	manpower reserve affairs and logistics
MRF	milestone reference file
MRRT	mean requisition response time
MRT	mean repair time
MSBM	mean sorties between maintenance
MSK	mission support kit
MSRT	mean supply response time
MST&E	multiservice test and evaluation
MTA	mean time to assemble
MTBCF	mean time between critical failures
MTBD	mean time between demands
MTBDE	mean time between downing events
MTBF	mean time between failures
MTBM	mean time between maintenance actions
MTBOS	mean time to break out of storage
MTBR	mean time between removals
MTBUMA	mean time between unscheduled maintenance actions
MTRRM	mean time to remove and replace modules
MTS	maintenance training support
MTSCO	mean time to shop checkout
MTTD	mean time to deliver
MTTF	mean time to failure
MTTR	mean time to repair
MTTRF	mean time to restore function
MTTRS	mean time to restore system
MTTS	mean time to service

ABBREVIATIONS (continued)

MTTT	mean time to troubleshoot
MTUWC	mean time to underwing checkoutNDInondestructive inspection
NMC	not mission capable
NMCB	not mission capable, both (i.e., maintenance and supply)
NMCM	not mission capable, maintenance
NMCS	not mission capable, supply
NRTS	not reparable this station
OA	Directorate of Analysis, AFOTEC obligation authority operational assessment
OCM	on-condition maintenance
OJCS	Organization of Joint Chiefs of Staff
OL	operating location
OMB	Office of Management and Budget
OPR	office of primary responsibility
OPSEC	operational security
OPTEVFOR	Operational Test and Evaluation Force (US Navy)
OR	operationally ready
ORD	operational requirements document
ORLA	optimum repair level analysis
O&S	operational and support (usually used in relation to cost)
O/S CMP	operational/support configuration management procedures
OSD	Office Secretary of Defense
OT	operating time
OT&E	operational test and evaluation
OTEA	Operational Test and Evaluation Agency (US Army)
OU	operational unit (sorties, operating hours, flight hours, etc.)
OUE	operational utility evaluation
P	delay time in preventive maintenance
PAD	program action directive
PAR	program assessment review
PCA	physical configuration audit
PCN	production control number
PCR	program change request or publication change request
PDM	programmed depot maintenance
PDR	program decision memorandum
PDM	preliminary design review
PEM	program element monitor
PHT	packaging, handling, and transportation
PID	program introduction document
PMC	partially mission capable
PMCB	partially mission capable, both (i.e., both maintenance and supply)
PMCM	partially mission capable, maintenance
PMCS	partially mission capable, supply
PMD	program management directive
PME	precision measurement equipment
PMEL	precision measurement equipment laboratory
PMP	program management plan
PO/ILSO	program office/integrated logistics support office
POL	program objective memorandum

ABBREVIATIONS (continued)

POM	program objective memorandum
PPBS	planning, programming, budgeting system
PRAT	production reliability acceptance test
PSOC	preliminary system operation concept
QAP	questionnaire analysis program
QED	quantitative evaluation of deficiencies
Q-GERT	queue-graphics evaluation review technique
QOT&E	qualification operational test and evaluation
QPA	quantity per application
QTAT	quick turnaround time
R	reliability
RAD	reliability analysis center
RADC	Rome Air Development Center
RAM	reliability, availability, and maintainability
RCMP	reliability-centered maintenance program
RCS	report control system
R&D	research and development
RDGT	reliability development/growth testing
RDT&E	research, development, test and evaluation
RFP	request for proposal
RILSA	resident integrated logistics support activity
RLA	repair-level analysis
R&M	reliability and maintainability
RMMP	reliability, maintainability management plan
RPIE	real property installed equipment
RQT	reliability qualification tests
RT	recovery time
RTO	responsible test organizations
RTOK	retest okay
SAC	Strategic Air Command
SAF	Secretary of the Air Force
SAR	selected acquisition reports
SATAF	site activation task force
SBSS	standard base supply system
SCIR	subsystem capability impact reporting
SCL	system command language
SCP	system concept paper
SD	Space Division (Air Force Systems Command)
SDDM	Secretary of Defense decision memorandum
SE	support equipment
SECDEF	Secretary of Defense
SEDS	system effectiveness data system
SEM	software evaluation manager
SETM	software evaluation team member
SGR	sortie generation rate
SIOP	single integrated operational plan
SISMS	standard integrated support management system
SLAM	simulation language for alternative modeling
SM	system manager
SMR	source, maintainability, recoverability

ABBREVIATIONS (continued)

SOC	system operational concept
SOW	statement of work
SPO	system program office
SPR	secretarial program review
SR	service report
SRD	standard reporting designator
SRU	shop-replaceable unit
ST	standby time
ST/BIT	self-test/built-in test
TAC	Tactical Air Command
TAFT	test-analyze-fix test
TAIDB	tank-automotive integrated data base
TAT	turnaround time
TCM	total corrective maintenance time
TCTO	time compliance technical order
TD	test directive
TDR	teardown deficiency report
TDSD	training device support data
TDT	total downtime (TMT & ALDT)
T&E	test and evaluation
TE	Directorate of Test and Evaluation, AFOTTEC
TEMP	test and evaluation master plan
T/G	threshold and goals
T&HP	transportation and handling provisions
TIP	test implementation plan
TMT	total active maintenance time (TCM + TPM)
TO	technical order
T _o	random time
TOIPR	technical order in process review
TOM	test operating manual
TO V&V	technical order validation and verification
TPG	test planning group
TPM	total scheduled maintenance time
TPO	test program outline
TPR	training program requirements
TPWG	test planning working group
TRANSEC	transmission security
TRD	test requirements document
TS	training suitability
TSE	top secret
TSTM	training supportability evaluators
TT	training supportability test manager
	total time (possessed time in AFR 66-110)
UDL	unit detail listing
UR	uptime ratio
USDRE	Under Secretary of Defense for Research and Engineering
VETMIS	vehicle technical management system
VIDS/MAF	visual information display system/maintenance action forms

ABBREVIATIONS (continued)

V&V	validation and verification (of technical orders) verification and validation (of software)
WBS	work breakdown structure
WDC	when-discovered code
WRM	war reserve material
WRSK	war readiness spares kit
WRU	weapon-replaceable unit
WSESA	weapon system and equipment support analysis
WSR	weapon system reliability
WUC	work unit code
XP	Directorate of Plans and Policy, AFOTEC

DATA ITEM DESCRIPTION	Form Approved OMB No. 0704-0188
------------------------------	------------------------------------

2. TITLE

SOFTWARE MATURITY/RELIABILITY DATA

1. IDENTIFICATION NUMBER

3. DESCRIPTION/PURPOSE

- 3.1 The software maturity/reliability data identifies problems detected in the deliverable software or documentation that has been placed under contractor configuration control.
- 3.2 The software maturity/reliability data are used by HQ AFOTEC to support early operations assessments (EOAs) and initial operational test and evaluation (IOT&E).

4. APPROVAL DATE
(YYMMDD)

5. OFFICE OF PRIMARY RESPONSIBILITY (OPR)

6a. DTIC REQUIRED

6b. GIDEP REQUIRED

7. APPLICATION/INTERRELATIONSHIP

- 7.1 This Data Item Description (DID) contains the format and content preparation instructions for data generated under the work task described by paragraphs 4.1.9 and 4.1.10.
- 7.2 The Contract Data Requirements List should specify whether these data are to be prepared and delivered on bound 8 1/2 by 11 inch bond paper or electronic media. If electronic media are selected, the precise format must be specified.

(continued on page 2)

APPROVAL LIMITATION

9a. APPLICABLE FORMS

9b. AMSC NUMBER

10. PREPARATION INSTRUCTIONS

10.1 Content and format instructions. Production of these data using automated techniques is encouraged. Specific content and format instructions for these data are identified below:

- a. Response to top tailoring instructions. In the event that a paragraph or subparagraph has been tailored out, a statement to that effect shall be added directly following the heading of each such (sub)paragraph. If a paragraph and all of its subparagraphs are tailored out, only the highest level paragraph heading need be included.
- b. Use of alternate presentation styles. Charts, tables, matrices, or other presentation styles are acceptable when the information required by the paragraphs and subparagraphs of this DID can be made more readable.
- c. Format. The preferred format is on electronic medium as specified in the following paragraphs.
- d. Document control numbers. For hardcopy formats, this document may be printed on one or both sides of each page (single-sided/double-sided). All printed pages shall contain the document control number and the date of the document centered at the top of the page.

10.2 On a monthly basis, the contractor shall supply the following data for each software problem or enhancement in the specific format on a 5 1/4" floppy disk, IBM PC format, or VAX VMS/readable 9 track tape. The preferred file structure is DBase III+ or equivalent.

(continued on page 2)

11. DISTRIBUTION STATEMENT

DISTRIBUTION STATEMENT A. Approved for public release; distribution is unlimited.

7. APPLICATION/INTERRELATIONSHIP (continued)

7.3 Submission of software maturity/reliability data will begin with configuration control of the software at full-scale development (FSD).

7.4 HQ AFOTTEC will use the data and send results to the system program office (SPO) for further dissemination.

10. PREPARATION INSTRUCTIONS (continued)

<u>Description</u>	<u>DBase III+ Type</u>	<u>Format Length</u>
a. Software Problem Number	Character	10
b. Description of Problem	Character	42
c. CSCI affected	Character	10
d. Priority of the Problem (1-5) 1 is the most severe and 5 the least. IAW 2167A Appendix C	Character	1
e. Date problem discovered	Date	8
f. Date problem was fixed	Date	8
g. Date problem was closed (implemented and verified)	Date	8
h. Enhancement/Fault (E or F)	Character	1
i. Number of lines of code added (executable source lines)	Numeric	6
j. Number of lines of code changed (executable source lines)	Numeric	6
k. Number of lines of code deleted (executable source lines)	Numeric	6
l. Number of people it took to make the change	Numeric	5
1. Number of man-hours it took for skill level 3 to make changes.	Numeric	5
2. Number of man-hours it took for skill level 5 to make changes.	Numeric	5
3. Number of man-hours it took for skill level 7 to make changes.	Numeric	5
4. Number of man-hours it took for skill level 9 to make changes.	Numeric	5
5. Number of man-hours for engineers to make changes.	Numeric	5
m. Number of occurrences of the same problem	Numeric	5
n. Function affected. The operational function of the component affected by the trouble.	Character	MEMO
o. Responsible Module. Component to which programmer isolated the problem and complete identification of the component, version, date, and any other significant component identification data.	Character	MEMO
p. Test Step. The test procedure and step being executed at the time the trouble was discovered (NA for documentation and logic troubles).	Character	MEMO
q. Testing. Describe the testing performed to verify the trouble and to ensure the correctness and completeness of the change(s).	Character	MEMO

10.3 On a monthly basis, the contractor shall supply the following day-to-day system failure data in the specific format on 5 1/4" floppy disk, IBM PC format, or VAX VMS/readable 9 track tape.

<u>Description</u>	<u>DBase III+ Type</u>	<u>Format Length</u>
a. Date	Date	3
b. Action taken: - (sys_idle --> system is idle, not running relevant programming) - (sys_on --> system turned on) - (sys_off --> system powered down by operation) - (Software problem number) - (Hardware problem number) - (sys_sw --> running system software)	Character	10
c. Time of action (military clock) no seconds	Numeric	4

10.4 On a monthly basis, the contractor shall supply the following test data in the specific format on 5 1/4" floppy disk, IBM PC format, or VAX VMS readable 9 track tape.

<u>Description</u>	<u>DBase III+ Type</u>	<u>Format Length</u>
a. Test Identification Number	Character	10
b. Test Description	Character	MEMO
c. Scheduled Test Date	Date	8
d. Completed Test Date	Date	8
e. Test Status (S - successful test) (F - failed test) (I - incomplete test)	Character	1