

**ID-A235 912**



MRL-TR-90-032  
IRI-90-59

**PROCEEDINGS OF THE 18TH CONFERENCE ON TOXICOLOGY — 1-3 NOVEMBER 1988**

Technology Services Corporation  
Woodman Drive, Suite 12  
Dayton, Ohio 45431

July 1990

ANNUAL REPORT FOR PERIOD 1-3 NOVEMBER 1988

**DTIC  
ELECTE  
MAY 24 1991  
S B D**

Approved for public release; distribution is unlimited

ARMSTRONG AEROSPACE MEDICAL RESEARCH LABORATORY  
MAN SYSTEMS DIVISION  
AIR FORCE SYSTEMS COMMAND  
RIGHT-PATTERSON AIR FORCE BASE, OHIO 45433-6573

**91-00472**



91 0 23 071

## NOTICES

When U S Government drawings, specifications, or other data are used for any purpose other than a definitely related Government procurement operation, the Government thereby incurs no responsibility nor any obligation whatsoever, and the fact that the Government may have formulated, furnished, or in any way supplied the said drawings, specifications, or other data, is not to be regarded by implication or otherwise, as in any manner licensing the holder or any other person or corporation, or conveying any rights or permission to manufacture, use, or sell any patented invention that may in any way be related thereto.

Please do not request copies of this report from the Harry G. Armstrong Aerospace Medical Research Laboratory. Additional copies may be purchased from:

National Technical Information Service  
5285 Port Royal Road  
Springfield, Virginia 22161

Federal Government agencies and their contractors registered with Defense Technical Information Center should direct requests for copies of this report to:

Defense Technical Information Center  
Cameron Station  
Alexandria, Virginia 22314

### TECHNICAL REVIEW AND APPROVAL

AAMRL-TR-90-032  
NMRI-90-59

The experiments reported herein were conducted according to the "Guide for the Care and Use of Laboratory Animals," Institute of Laboratory Animal Resources, National Research Council.

This report has been reviewed by the Office of Public Affairs (PA) and is releasable to the National Technical Information Service (NTIS). At NTIS, it will be available to the general public, including foreign nations.

This technical report has been reviewed and is approved for publication.

FOR THE COMMANDER



JAMES N. McDOUGAL, Maj, USAF, BSC  
Deputy Director, Toxic Hazards Division  
Harry G. Armstrong Aerospace Medical Research Laboratory

## REPORT DOCUMENTATION PAGE

*Form Approved*  
*OMB No. 0704-0188*

Public reporting burden for this collection of information is estimated to average 1 hour per response, including the time for reviewing instructions, searching existing data sources, gathering and maintaining the data needed, and completing and reviewing the collection of information. Send comments regarding this burden estimate or any other aspect of this collection of information, including suggestions for reducing this burden to Washington Headquarters Services, Directorate for Information Operations and Reports, 1215 Jefferson Davis Highway, Suite 1204, Arlington, VA 22202-4302, and to the Office of Management and Budget, Paperwork Reduction Project (0704-0188), Washington, DC 20503

<b>1. AGENCY USE ONLY (Leave Blank)</b>	<b>2. REPORT DATE</b> July 1990	<b>3. REPORT TYPE AND DATES COVERED</b> Final -Nov. 1988 to Nov. 1988	
<b>4. TITLE AND SUBTITLE</b> Proceedings of the 18th Conference on Toxicology		<b>5. FUNDING NUMBERS</b> PE 62202F PR 6302 TA 630200 WU 63020001 Accession No. 331790	
<b>6. AUTHOR(S)</b>		<b>8. PERFORMING ORGANIZATION REPORT NUMBER</b>	
<b>7. PERFORMING ORGANIZATION NAME(S) AND ADDRESS(ES)</b> NSI Technology Services Corporation 101 woodman Drive, Suite 12 Dayton, Ohio 45431		<b>10. SPONSORING/MONITORING AGENCY REPORT NUMBER</b> AAMRL-TR-90-032 NMRI-90-59	
<b>9. SPONSORING/MONITORING AGENCY NAME(S) AND ADDRESS(ES)</b> AAMRL, Toxic Hazards Division HSD, AFSC Wright-Patterson AFB, Ohio 45424-6573		<b>11. SUPPLEMENTARY NOTES</b>	
<b>12a. DISTRIBUTION/AVAILABILITY STATEMENT</b>  Approved for public release; distribution is unlimited.		<b>12b. DISTRIBUTION CODE</b>	
<b>13. ABSTRACT (Maximum 200 words)</b>  The 18th Conference on Toxicology addressed contemporary initiatives in quantitative toxicology and provided a forum for the presentation of state of the science methodologies and ideas. These presentations and subsequent interactions provide a format which assists the Department of Defense in quantifying the risks associated with the chemicals encountered in its operations. the papers in this report were given in one of the conference sessions which were; Strategies for Improving Toxicity Testing, Toxicities and Interactions of Mixtures, Experimental Data and Carcinogenesis Models, Environmental Modeling, and Advanced Techniques in Hazard Management.			
<b>14. SUBJECT TERMS</b> Carbon tetrachloride      Chloroform      Exposure assessment Carcinogenesis          Emergency response      Genotoxicity testing Chlorodecone            Environmental modeling      Hazard assessment			<b>15. NUMBER OF PAGES</b> 408
			<b>16. PRICE CODE</b>
<b>17. SECURITY CLASSIFICATION OF REPORT</b> UNCLASSIFIED	<b>18. SECURITY CLASSIFICATION OF THIS PAGE</b> UNCLASSIFIED	<b>19. SECURITY CLASSIFICATION OF ABSTRACT</b> UNCLASSIFIED	<b>20. LIMITATION OF ABSTRACT</b> UL

**14. SUBJECT TERMS (continued)**

**LD50**

**Median lethality**

**Mixtures**

**Pharmacokinetic model**

**Physiologically-based models**

**Quantitative structure activity relationship**

**Radon**

**Risk assessment**

**Stem cell**

**Submarine atmosphere**

**Toxicity testing**

**Trichloroethylene**

**Two stage model**

**PREFACE**

The 18th Conference on Toxicology was held in Dayton, Ohio, on 1-3 November 1988. The Conference was sponsored by NSI Technology Services Corporation Environmental Sciences (NSI-ES), under the terms of Contract No. F33615-85-C-0532 with the Harry G. Armstrong Aerospace Medical Research Laboratory (AAMRL), Human Systems Division, Air Force Systems Command, Wright-Patterson Air Force Base, Ohio; and the Naval Medical Research Institute Toxicology Detachment (NMRI/TD), Wright-Patterson Air Force Base, Ohio.

Colonel John J. Coughlin, Human Systems Division, Brooks AFB, TX, served as Conference Chairman. Deborah Ussery-Baumrucker, NSI-ES, was Conference Coordinator. Lois Doncaster, NSI Toxic Hazards Research Unit (THRU), provided administrative support in Dayton.

<b>Accession For</b>	
NTIS GRA&I	<input checked="" type="checkbox"/>
DTIC TAB	<input type="checkbox"/>
Unannounced	<input type="checkbox"/>
Justification _____	
By _____	
Distribution/	
<b>Availability Codes</b>	
Dist	Avail and/or Special
A-1	



## TABLE OF CONTENTS

	PAGE
OPENING REMARKS .....	5
James N. Woody, CAPT, MC, USN	
WELCOME ADDRESS .....	9
John J. Coughlin, Col, USAF, BSC	
INTRODUCTORY ADDRESS .....	12
Dr Melvin E. Andersen	
SESSION I – STRATEGIES FOR IMPROVING TOXICITY TESTING .....	16
Dr Raymond S. Kutzman	
A QSAR MODEL FOR THE ESTIMATION OF CARCINOGENICITY. EXAMPLE APPLICATION TO AN AZO DYE .....	17
Mr Kurt Enslein	
A COMPUTER-ASSISTED PROCEDURE FOR THE ASSEMBLY AND ANALYSIS OF SHORT-TERM GENOTOXICITY TEST DATA .....	33
Dr David Brusick	
IMPROVING TOXICOLOGY TESTING PROTOCOLS USING COMPUTER SIMULATIONS ...	52
Harvey J. Clewell III, LtCol, USAF, BSC	
ALTERNATIVE APPROACHES IN MEDIAN LETHALITY (LD <sub>50</sub> ) AND ACUTE TOXICITY TESTING .....	73
Dr Linval R. DePass	
TRIGGERS FOR HIGHER ORDER TOXICITY TESTING .....	85
Dr Bernard A. Schwetz	
PANEL DISCUSSION .....	93
SESSION II – TOXICITY AND INTERACTIONS OF MIXTURES .....	102
Dr Raymond S.H. Yang	
TOXICOLOGY OF CHEMICAL MIXTURES: EXPERIMENTAL APPROACHES, UNDERLYING CONCEPTS, AND SOME RESULTS .....	103
Dr Raymond S.H. Yang	
TOXICOLOGICAL EVALUATION OF COMPLEX INDUSTRIAL WASTES: IMPLICATIONS FOR EXPOSURE ASSESSMENT .....	119
Dr David M. DeMarini	

## TABLE OF CONTENTS (Continued)

	PAGE
MECHANISM OF THE LETHAL INTERACTION OF CHLORDECONE AND CCl <sub>4</sub> AT NONTOXIC DOSES .....	134
Dr Harihara M. Mehendale	
SUBMARINE ATMOSPHERES .....	165
Douglas R. Knight, CAPT, MC, USN	
STUDIES IN THE SYNERGISTIC HEPATOTOXICITY OF CARBON TETRACHLORIDE AND TRICHLOROETHYLENE OR CHLOROFORM IN MALE F-344 RATS .....	175
Dr I. Glenn Sipes	
PANEL DISCUSSION .....	176
SESSION III – EXPERIMENTAL DATA AND CARCINOGENESIS MODELS .....	187
Dr Rory B. Conolly	
GENETIC DETERMINANTS OF HEPATOCARCINOGENESIS IN THE B6C3F <sub>1</sub> MOUSE .....	188
Dr Norman R. Drinkwater	
THE SEQUENTIAL DEVELOPMENT OF CANCER: A MORPHOLOGIC PERSPECTIVE .....	200
Dr Scot L. Eustis	
STEM CELL THEORY OF CARCINOGENESIS .....	216
Dr James E. Trosko	
HETEROGENEITY OF ENZYME - ALTERED FOCI IN RAT LIVER .....	231
Mr Michael Schwarz	
RELATIONSHIP BETWEEN CELL REPLICATION AND CARCINOGENICITY OF NONGENOTOXIC AGENTS .....	255
Dr Thomas Goldsworthy	
PANEL DISCUSSION .....	256
LUNCHEON SPEAKER .....	262
Mr Gary D. Vest	
SESSION IV – ENVIRONMENTAL MODELING .....	269
Harvey J. Clewell III, LtCol, USAF, BSC	
HOUSEHOLD EXPOSURE MODELS .....	270
Dr Thomas E. McKone	

## TABLE OF CONTENTS (Continued)

	PAGE
MULTIMEDIA TRANSPORT OF ORGANIC CONTAMINANTS AND EXPOSURE MODELING .....	291
Dr David W. Layton	
RADON EXPOSURE ESTIMATES .....	303
Dr Bruce O. Stuart	
ATMOSPHERIC CHEMISTRY OF PROPELLANT VAPORS .....	310
Dr Daniel A. Stone	
THE APPLICATION OF TOXICOLOGICAL PARAMETERS IN EMERGENCY RESPONSE AND PLANNING .....	323
Ms Robin K. Wiener	
PANEL DISCUSSION .....	331
SESSION V – ADVANCED TECHNIQUES IN HAZARD ASSESSMENT .....	339
Dr Melvin E. Andersen	
RECENT CANCER RESEARCH RESULTS REQUIRE RISK ASSESSMENT CHANGES .....	340
Dr James D. Wilson	
EVALUATION OF UNCERTAINTY IN INPUT PARAMETERS TO PHARMACOKINETIC MODELS AND THE RESULTING UNCERTAINTY IN OUTPUT .....	341
Mr Bruce C. Allen	
RISK ASSESSMENT GUIDELINES .....	356
Dr William Farland	
DEALING WITH UNCERTAINTY IN CHEMICAL RISK ANALYSIS .....	357
David S. Clement, Capt, USAF	
ESTIMATING UNCERTAINTY .....	376
Dr Christopher J. Portier	
PANEL DISCUSSION .....	377
CLOSING REMARKS .....	384
John J. Coughlin, Col, USAF, BSC	
ABSTRACTS FOR POSTERS .....	385



## **OPENING REMARKS**

**Captain James N. Woody**

**Commander**

**Naval Medical Research and Development Command**

**Bethesda, MD**

Good Morning, Ladies and Gentlemen. Welcome to the 18th in the continuing series of Conferences on Toxicology sponsored by the Air Force and the Navy biomedical research community. I am Captain James Woody, Commanding Officer of the Naval Medical Research and Development Command, which looks after medical research in the Navy. I am a physician, a pediatrician, and an immunologist. I have had some experience in administering fairly toxic agents to patients to disable their immune system for transplantation, so I have some feeling for some of the problems that you enjoy and look after over long terms. My purpose in these opening remarks this morning is to set the stage for this Conference. I will try to provide you with a brief history of the Conference series, identify the laboratories involved here, and give you a feel for why we believe this association is extremely valuable.

This Conference traces its roots to an early concern with the toxicity of atmospheric contaminants in sealed cabins and submarines. The initial symposium, "Submarine and Space Medicine," was hosted by the Navy Medical Laboratory in New London, CT, in 1958. Those were times when long-term exposure to environmental hazards was becoming apparent as our submarines were beginning very long operational tours (three, six, eight months), and space flight was being considered as a realistic possibility. I may note that, during the previous year, the Navy Toxicology Unit was established as a separate command with a mission of evaluating the toxicology of materials as a result of such long-term exposures. A second symposium, "Toxicity in Closed Ecological Systems," was sponsored by the Navy's Special Projects Office and the Lockheed Missiles and Space Company; it was held in Palo Alto, CA, in 1963.

Recognizing the need for frequent contact among the scientists in this field, an annual conference series was initiated in 1965 here at the site of one of the premier facilities for such work. For the first five years it was entitled "Atmospheric Contamination in Confined Spaces," with a major emphasis on the manned space flight program. In 1970, the scope was broadened, and this was reflected in the change of the Conference title to "Environmental Toxicology." In recent years, there has been an increasing interest in examining fundamental mechanisms, experimental methodology, and the application of toxicologic information to the wider field of risk assessment. This has resulted

in a further broadening of the scope, leading to the current title of our conference, "The Conference on Toxicology."

The association of various research activities and research facilities here deserves special mention. Our host, the Harry G. Armstrong Aerospace Medical Research Laboratory (AAMRL), is the Air Force's leading laboratory for toxicologic research. Its Toxic Hazards and Veterinary Sciences Divisions provide the basic scientific and laboratory animal support and infrastructure. Their authorized professional staff numbers 18. The Toxicology Detachment of the Navy Medical Research Institute has been located here at Wright-Patterson AFB since 1976 in a cost-sharing and intellectual cross-fertilization role. The Detachment is the direct descendent of the Navy Toxicology Unit I mentioned earlier. It is the Navy's primary laboratory for toxicological research and provides major input to our health risk assessment process. The authorized professional staff numbers seven.

The Toxic Hazards Research Unit (THRU) was established here by the Air Force in the early 1960s as a government-owned, contractor-operated research facility to perform toxicology in association with the parent Air Force activity, the AAMRL. This is the site of the Thomas Domes, a major inhalation exposure facility. It has recently been supplemented by a state-of-the-art ambient exposure laboratory designed by the contractor staff. Funding for the contract is on a cost-sharing basis; the Air Force provides 75% of the funds and the Navy 25%. Support is also provided on a fee-for-service basis to other government agencies such as NASA and the Department of Transportation. The current contractor is the NSI Technology Services Corporation, which maintains a professional research staff of 23 and is our host at the Conference here today.

Last year the Army joined this association by establishing the Army Medical Research Unit, Wright-Patterson AFB, to provide veterinary pathology and laboratory animal medicine support to the research facility. The current program has four people on board. The Army, because it has all of the veterinarians, supplies veterinary support and pathology to all of the military medical research facilities.

Close ties are maintained with the academic research community in the Dayton area. Joint appointments are held by lab personnel at universities and by university personnel at the laboratories. Several laboratory personnel are in advanced degree programs at local universities. I want to give you one example of how this has been extremely beneficial. Research into the formation and toxicity of a neurotoxic agent from the combustion of a turbine engine lubricant was being studied at the Navy laboratory. The Chemistry Department at Wright State University synthesized samples of this material and related compounds for use as authentic standards, and a graduate student in the Pharmacology Department adopted the identification of its specific mechanism of action for his thesis project.

The association of facilities here has turned out to be extremely valuable. Problems originally identified as relevant to one service turn out to have solutions applicable to other services. Results from basic research frequently are immediately pressed into service in support of applied investigations. The applied work, in turn, generally has direct significance, sometimes immediate significance, for operational concerns. A good example is the turbine lubricant I just mentioned.

This turbine lubricant is in wide operational use in the Navy, and there was a major concern that a fire involving this lubricant might produce a neurotoxic gas that could lead to some fatalities. Our Toxicology Detachment performed bioassays of the combusted fluid and the combustion atmosphere. Our staff quickly determined that the lubricant did indeed produce the highly neurotoxic compound, called trimethylolpropane phosphate (TMP-P), and that the oil that condensed after combustion did contain significant amounts of it. On exposure to the combustion atmosphere, however, no animals died in the manner characteristic of the deaths due to TMP-P exposure, which was unusual. It turns out that TMP-P condenses out with the oil and deposits on the surrounding surfaces at temperatures higher than it is possible to breathe and survive. Analysis of this data and its integration into the exposure scenario of concern led to a significant change in our perceptions of the hazards posed and the consequent risk assessment. This information, provided to the Fleet as soon as it was confirmed in the Laboratory, resulted in modifications to both damage control and fire fighting procedures and to cleanup procedures. The former had less to worry about; the latter were advised to take some additional cautions to minimize skin contact. This is a major achievement for our toxicology program because we would certainly find it very difficult to replace this turbine lubricant in a large operational force. To show that this, in fact, was not as hazardous under the circumstances, that other problems would be paramount, was of great interest and use to our operational forces.

The cost savings inherent in our cost-sharing arrangements are, from the point of view of the individual services, quite significant. A couple of examples of this interaction will demonstrate the benefits to be realized.

The combustion work mentioned earlier is being developed as a major joint program. A laboratory is being equipped and staffed by both the Navy and Air Force to investigate the toxicity of combustion products of specific service-use materials. The data will be used as input to develop a predictive model based on the results of exposures and to investigate the mechanisms of this toxicity. Both the materials tested and the models to be developed have direct application to all the services and to the private sector as well. In work initiated separately and performed by the THRU, both the Air Force and the Navy have investigated the toxicity of oligomers of chlorotrifluoroethylene, or CTFE. Review of the results indicated that these different oligomers shared a common mechanism of toxicity. Furthermore, data from a previous experiment appeared relevant to this interpretation. This

has led to a new study to elucidate their comparative toxicity based on variations in chain length and halogen substitution. Application of the results will be pertinent not only for the original materials, which are a lubricant and a candidate hydraulic fluid, but also to many similar materials that have wide-spread military and civilian applications. These results should also be valuable input for the design of similar materials as part of the process of balancing engineering performance and toxicity.

I hope I have been able to give you a brief overview of the many exciting lines of work being performed here. I have not mentioned our work in assessing reproductive toxicology. As we deploy more women in our Fleet, in our services, this becomes of some concern. This will be a major theme of the Navy's 31st Occupational Health Workshop to be held this March at Virginia Beach. Another area is assessing performance decrement on exposure to environmental toxicants. This is an area that has achieved a great deal of interest recently as we move toward more collective protection environments both on our ships and in other areas. The large number of Air Force programs is also highly significant.

This year's Conference will review several areas of active research that are transforming toxicology from a descriptive to a quantitative science and that have significant impact on the applications of toxicologic information to the risk assessment process. Colonel John Coughlin, in the Welcoming Address, will provide more details on the changing face of toxicology and its application to the real-world problems we must all contend with. Dr. Melvin Andersen, Senior Scientist for the Toxic Hazards Division here at the Armstrong Aerospace Medical Research Laboratory, will then illustrate how the individual sessions support the Conference goal.

I would now like to introduce Colonel John Coughlin, the Conference Chairman, who will be giving the Welcoming Address. Colonel Coughlin is the Deputy for Environmental Protection at the Human Systems Division of the Air Force Systems Command.

## **WELCOME ADDRESS**

**Colonel John J. Coughlin**

**Deputy for Environmental Protection**

**Human Systems Division**

**Brooks Air Force Base, TX**

Good Morning, Ladies and Gentlemen. I am John Coughlin, the Deputy for Environmental Programs in the Air Force Systems Command's Human Systems Division, headquartered at Brooks AFB, the parent organization of our host laboratory today, AAMRL.

On behalf of my boss, Major General Doppelt, the Commander of the Human Systems Division, it is indeed my pleasure to welcome you to this 18th Conference on Toxicology. This year's Conference provides an excellent selection of presentations on a very broad range of topics. Both environmental and occupational issues will be addressed, and considerable emphasis will be placed on contemporary initiatives in quantitative toxicology, the theme of this year's Conference.

My first exposure to quantitative toxicology was some 18 years ago while I was assigned at Space and Missile Systems Organization in Los Angeles. At that time, SAMSO was preparing to transfer or extend the Titan space launch operations from our east coast launch site at Patrick AFB to the west coast launch site at Vandenberg AFB. And, of course, with different demography, totally different micrometeorological conditions, not to mention the very near proximity of one of the largest commercial flower fields in the country at the Vandenberg launch site, General Phillips, then SAMSO commander, had several questions concerning risk assessment and the likely toxicological and environmental consequences of that west coast bed-down of Titan operations. Those questions gave me my first opportunity to visit the Toxic Hazards Division here at AAMRL, and I found that the science and technology base existing in the Air Force and the Toxic Hazards Division was indeed expert. I gave them a list of the boss' questions, and in two days I had a beautiful three-page point paper, succinct and to the point, based on the Farmers' Almanac, the Burpee Seed Catalog, and demographics in the most recent census, that indeed gave a quantitative risk assessment of the likelihood of environmental damage associated with Titan operations out of Vandenberg and in the surrounding area. But the senior scientist at the time felt, as I was departing, that I needed my first lesson in quantitative toxicology and he said "John, now you must remember, toxicologists are a very discrete, distinct, and disciplined category of scientists, and before we can give a risk assessment, we must be totally confident that we are 100% right, at least 14.25% of the time." With that perspective, I was somewhat less enamored about going back and briefing General Phillips.

Fortunately, for the good of the Titan program and for the future of quantitative toxicology, not to mention the future of a then young captain, the Toxic Hazards Division has proven to be 100% right far more frequently than 14.25% of the time over the last 28 years I have been privileged to work with them.

Although the emphasis of these conferences has changed over the years, they have all shared one unique element; that is, providing a forum that encourages personal participation in the exchange of knowledge, an opportunity to roll up our shirt sleeves, loosen our ties, and honestly exchange ideas and opinions face to face. I trust this Conference will continue this fine tradition. Remembering this, I strongly encourage each of you to contribute your candid opinions and constructive guidance to these discussions. The success of the Conference depends on each of you actively participating.

This year's emphasis on contemporary initiatives in quantitative toxicology is indeed timely. In the past, much of toxicology was purely descriptive and we have indeed come a long way from counting up-turned limbs and dividing by four. Today's toxicologist is tasked with an enormous responsibility; a responsibility to identify potentially hazardous substances from an ever-increasing universe of new chemicals and materials, and with ever-decreasing resources. This frequently means less money, less equipment, less animals, and most assuredly, always less time. We simply no longer have the luxury of performing studies on large numbers of animals to identify the adverse effects of every chemical now known to man. These methods are neither cost-effective nor sufficiently timely for providing crucial evaluations in a society that is aggressively pursuing tomorrow's technologies and systems today. The stark reality has moved us into the light of quantitative toxicology.

Techniques are emerging that show promise to effectively screen and to reliably predict the effects of potentially hazardous substances on man. This is accomplished through strategic toxicity tests and computer simulation. However, the computer axiom – garbage in, garbage out – holds especially true in this promising field of quantitative toxicology. More than ever, it is important to carefully design and perform studies that will provide high-quality data that can be relied upon and followed up on computer simulations. In turn, computer simulations make viable alternatives to animal testing possible and will reduce the number of animal studies required by providing more effective experimental design and analyses. There is growing recognition of the need for more scientifically valid methods of estimating a quantitative risk from a given environmental or occupational exposure. It would be wonderful if we could totally eliminate the potential for exposure to any chemical for which there was any evidence of toxicity; however, such is not the case. Realities are that cost benefit decisions must be made and the scope of the task is sobering.

Estimates of total cost for Superfund remedial actions alone are expected to be more than 150 billion dollars by the year 2000. These hazardous waste sites must be prioritized because obviously, from an economic view alone, they cannot all be cleaned up at once. This prioritization is critically dependent on an accurate assessment of the risk entailed by exposure to what is often a complex mixture of chemicals of varying toxic effects. These decisions will hinge on a determination of potential risk. The proper resolution of these and many other questions requires the development of quantitative modeling techniques. We are proud of the advances in this area that have been made at the Toxic Hazards Division of the Armstrong Aerospace Medical Research Laboratory, but much remains to be done, as should be clear at the close of today's session alone.

I am excited by the potential of quantitative toxicology and believe that this Conference will indeed capture some of that potential. I hope you agree and will give your full support toward making the Conference fruitful. Again, welcome and best wishes for a successful conference.

I am pleased now to have the opportunity to introduce Dr Melvin Andersen, Senior Scientist for the Toxic Hazards Division, who will provide a few introductory comments on the technical content of the agenda for the next two and one-half days. Thank you.

## INTRODUCTORY ADDRESS

Dr Melvin E. Andersen  
Senior Scientist  
Toxic Hazards Division  
Wright-Patterson Air Force Base, OH

I was very pleased this morning to be here in the audience and listen to Captain Woody and Colonel Coughlin talk. I have ties to both the Navy and the Air Force part of the program at Wright-Patterson. I came to Wright-Patterson AFB in 1977 with the Navy group from Bethesda, MD. I had joined the Navy because I was from New England and liked the water. But after six years they sent me to Ohio. I was afraid that with that kind of direction I best do something about it. In 1977 I left the Navy and joined the Air Force Toxic Hazards Division as a civilian. I have been here ever since. The two gentlemen who have talked to you represent the higher DOD echelons to which the toxicology organizations report; that is, they represent the Navy Medical Research and Development Command and the Human Systems Division. It is through the support of these organizations that the toxicology groups here at Wright-Patterson AFB have been able to maintain viable, productive programs that have been contributory to the efforts of both services. In the past two years, we have also welcomed the Army Pathology Unit here to Wright-Patterson to provide tri-service representation in our toxicology efforts.

My total service here has spanned only 10 years, a small portion of what really is quite a successful history of this laboratory. It is a history that goes back to concerns that both the Air Force and the Navy had for the toxicity of materials in closed atmospheres. In response to those needs, the organizations independently, the Navy in Bethesda, MD, and the Air Force here at Wright-Patterson, established units to conduct continuous exposures on animals for what was then quite long periods of time: 90 days or even 180 days. These experiments were really unheard of in the late '50s and early '60s and much of the early work in what was considered chronic toxicology was done by the two services for a very particular reason: to support military systems in which men and women would be chronically exposed for these longer periods of time. At Wright-Patterson, the organization developed contained both contractor-operated facilities as well as an in-house research staff. The Navy's facility in Bethesda was predominantly an in-house research organization.

Last year when I introduced the Conference, I explained that much of the early work done by both organizations, not unlike work done by other federal organizations or industrial sector toxicology laboratories, was primarily observational in nature. A good deal of information needed to be accumulated on a whole variety of chemicals that had been poorly studied to that point. These were chemicals that were going to be found in the various space and enclosed systems that the Air



Force and Navy were interested in. For many years there was a significant backlog of chemicals to be studied and the services had their hands full with routine testing needs. As that backlog cleared up somewhat, there were questions raised about the value and interpretability of some of these experiments. In the Air Force side of this operation, starting about 10 years ago, there were efforts made to develop programs to look at the relevant tissue dose that was derived from exposures to particular chemicals. At that time Dr Ken Back and Ms Marilyn George developed a laboratory development plan in pharmacokinetics. This was a significant initiative toward a more quantitative approach to looking at the disposition of chemicals. More importantly, this plan also represented development of an intellectual strategy of how you might begin to interpret these toxicology experiments in a quantitative way.

These changes, from observational approaches to approaches that combine careful, detailed, observational toxicology studies with more quantitative descriptions of the disposition of chemicals and the likely impact that disposition would have on biological outcome, have developed slowly, but the approach is now fundamental in our approach to hazard identification with toxic materials. Part of that improvement is coming about as we have increased the size of the operation here, especially the interactions between the Navy and the Air Force and other local organizations including Wright State University and the University of Dayton.

Last year's Conference, as those of you who were here will remember, featured one of the country's first conferences with a give-away computer. It was only on a poster, but we felt it was at least symbolic that there was an effort here in our Laboratory to incorporate quantitative modeling into the very fabric of studies on chemical toxicology. This modeling approach is as an adjunct to good, careful observational and mechanistic studies. It aids in interpretation and helps in assessing the relevance of animal studies for people. Last year's Conference stressed advances in pharmacokinetic modeling and pharmacodynamic modeling, quantitative structure-activity relationships and the development of some new techniques, such as in flow cytometry. This year we have tried to extend this concept of quantitative toxicology into some new areas, and we hope that this will be a continuing emphasis of the Conference.

So today we begin a Conference that has five sessions. The overall theme that ties the Conference together is contemporary initiatives in quantitative toxicology. There is a session on strategies for improving toxicity testing, and I won't really discuss this one in very great detail because Dr Ray Kutzman will come up and tell you what he thinks that session's going to be. I can discuss the other four, because I suspect that you will forget whatever remarks I make before the session chairmen introduce them.

It is clear that there are two processes involved in improving our ability to extrapolate laboratory results from the animals that we test to people. One is to have a better understanding of what happens in the animals and make sure that the experiments give information on the factors that are common between the test animals and humans. One thing that we must always have our minds on is doing the best possible toxicity tests, and the first session discusses this. We should also consider improvements in toxicity testing using various screens and other approaches to finding an economical and efficient way of doing toxicology testing on the many different chemicals.

The second session is on toxicity and interaction of mixtures. The session chairman, Dr Yang, likes to tell me, after I get done spouting off about doing pharmacokinetics and being quantitative, that it's easy for me to say because I am only interested in one chemical at a time. People out there in the real world are interested in enormously complex mixtures of chemicals. In the Installation Restoration Program of the Air Force, we are concerned with all the chemicals that are found in water supplies and the atmosphere near some bases. These systems are really very complex mixtures of large numbers of chemicals.

In the third session on experimental data and carcinogenesis models, we are actually bringing a group of people together to help the staff here as we work through a particular problem in pharmacokinetics and pharmacodynamic modeling of cancer. There are new initiatives in quantitative toxicology to develop realistic two-stage models for the cancer process. There are very elegant theoretical and intellectual constructs, but they lack a good strong data base at present. We have to learn much more about the processes that are described by these quantitative models and help use these models to design better experiments. We hope that bringing this group of experts together will help our own staff in addressing some of these difficult questions.

The fourth session is on environmental modeling. This session recognizes the fact that we are interested in two problems in toxicology. One, the toxicology of the chemicals in a particular organism emphasizes the effect of the chemical directly. The second part of the real world problem is exposure. How likely are people to be exposed to particular chemicals? The fourth session describes environmental modeling in a very general way, looking at multimedia types of exposure for different chemicals.

I will chair the fifth session as a last minute replacement for Colonel Mike McNaughton. This session is on advanced techniques in hazard assessment. It takes a look at some of the new initiatives and how you incorporate a variety of biological and toxicological information into actually making risk assessments and hazard assessments. A good bit of this session will focus on estimating uncertainties in cancer risk assessment approaches.

We hope that the common theme that ties this Conference together is the need for quantitative information to be developed in toxicology. This information is especially necessary for decision-making in terms of setting acceptable human exposure limits. The Conference's purpose is to bring together a variety of people, representatives from the Department of Defense (Air Force, Navy, and Army), from academia, from other laboratories in the federal sector, and from industry, to discuss these questions actively in a common environment that will help us here at the Toxic Hazards Division and the Navy Toxicology Detachment to do our job better.

I ask that you not be bashful. As Colonel Coughlin said, this is a chance to listen, learn, and interact. The sessions are arranged such that there will be a short time after each talk for some discussion and points of clarification, and there will be a chance at the end of each session for all of the speakers to come up to the podium where we can have a joint discussion period. It's been one of the goals of all of our Conferences to make those discussion sessions as active as possible, and they have frequently been that – active and informative for all of us. We hope that we can continue that tradition with our Conference here today.

**SESSION I**

**STRATEGIES FOR IMPROVING TOXICITY TESTING**

**Dr Raymond S. Kutzman, Chairman**

# A QSAR MODEL FOR THE ESTIMATION OF CARCINOGENICITY. EXAMPLE APPLICATION TO AN AZO DYE

Kurt Enslein and Harold H. Borgstedt

*Health Designs, Inc., 183 East Main Street, Rochester, NY 14604*

## SUMMARY

Because carcinogenicity bioassays are time-consuming, costly, and use animal resources, structure-activity relationship (SAR) equations that model toxicological endpoints have been developed to make alternative methods available which approximate the results that could be obtained from bioassays, but which are less expensive and time-consuming and use fewer, if any, animals. These equations are based on sets of bioassay results and explain the endpoint under consideration in terms of substructural and other parameters that describe the chemical entities. The resulting equations – or models – can then be used to estimate – or predict – the endpoint for new structures. The estimation is followed by validation procedures.

## INTRODUCTION

SAR models have been developed for several toxicity endpoints, including carcinogenicity [1], mutagenicity (Ames) [2], skin irritation [3], eye irritation [4], teratogenicity [5], rat oral LD<sub>50</sub> [6], *Daphnia magna* EC<sub>50</sub> [7], fathead minnow LC<sub>50</sub> [8], and biodegradability [9]. The following discussion is limited to a model of carcinogenicity.

### *History of the Use of QSAR*

SAR methodology in the development of pharmaceuticals and agricultural chemicals has been pioneered in the United States by Corwin Hansch [10]; only relatively recently have SAR methods been applied to toxicity endpoints. SAR models of toxic endpoints have been developed by, among others, Free and Wilson [11] and Wishnok et al. [12,13], who have developed carcinogenicity models, as have Klopman [14], Jurs et al. [15], Jurs [16], Yuta and Jurs [17], and Enslein et al. [1]. Most previous models differ from the one described in this paper principally in that they are based on homologous or at least closely related series of chemicals, whereas the model described here is based on a structurally heterogeneous set.

## MATERIALS AND METHODS

Model development begins with assembly of a data base of compounds for which carcinogenesis bioassay results are available. This is followed by selection of parameters that are potentially related to the endpoint. Regression and discriminant analysis techniques are then used to

select important parameters and weight them. Various validation procedures then follow. The entire process has been described in detail [1, 18].

#### **Data Bases**

The data base for the carcinogenesis model was assembled from National Cancer Institute/National Toxicology Program (NCI/NTP) rodent lifetime carcinogenesis bioassays for most of the carcinogens and 18 of the noncarcinogens. Additionally, ten clearly positive human carcinogens were selected from the Fourth Annual Report on Carcinogens [19].

Griesemer and Cueto [20] published a review of 196 NCI/NTP bioassays on 185 chemicals. They classified the chemicals according to the strength of evidence for or against carcinogenicity in rats and mice (see Table 1). Categories 1 through 5 contain compounds for which the evidence for carcinogenesis is more or less convincing. Categories 6, 7, and 8 contain compounds for which the evidence for or against carcinogenicity is too equivocal to permit evaluation, and Category 9 contains compounds for which negative evidence was deemed convincing. Griesemer and Cueto [20] have since reviewed reports published after their original publication [personal communication], including all reports and draft reports up to No. 330. Also included in this review were five reports on comparable studies conducted under the auspices of the Chemical Industry Institute of Toxicology.

**TABLE 1. NCI/NTP BIOASSAY DATA**

<b>Category</b>	<b>Evidence for Carcinogenicity</b>	<b>Number of Chemicals</b>
1	Very strong in two species	31
2	Very strong in one species, sufficient in second species	9
3	Very strong in one species, none in second species	33
4	Sufficient in two species	12
5	Sufficient in one species, none in second species	29
6, 7, 8	Equivocal, no determination possible	53
9	None in two species	18
<b>Total</b>		<b>185</b>

After removal of duplicates, mixtures, materials of uncertain chemical composition, and other compounds unsuitable for modeling, the numbers of chemicals shown in Table 1 were suitable for classification. As seen in Table 1, there were only 18 negative compounds, creating a very unbalanced distribution of carcinogens and noncarcinogens. Other sources of negative data were therefore considered.

IARC Reviews [21] and lists of compounds published in Public Health Service Publication 149 [22] were found to be inadequate because they included compounds for which at least some positive evidence existed, or chemicals that had been tested using unsuitable or questionable methodology. The (U.S.) Code of Federal Regulations, Vol. 21 [23] contains lists of chemicals that have been used, often in substantial quantities and for substantial lengths of time, as food additives and which are at least putatively noncarcinogenic.

Two hundred and ten chemicals were selected from these lists to represent a variety of chemical substructures. Repetitive series, isomers, compounds with repetitive substituents (as often found in flavor materials) were not included, as well as compounds with an uncertain status, such as eugenol.

*The Physician's Desk Reference* [24] contains manufacturer-supplied information on drugs marketed in the United States. Sometimes there are statements regarding the noncarcinogenicity of the drug in question, along with remarks about the testing protocol.

Additional information on these bioassay results was obtained from cooperative manufacturers or from the U.S. Food and Drug Administration to permit an evaluation of the adequacy of the testing, particularly in relation to comparability with standard NCI/NTP bioassays. Over 60 compounds were identified as negative on the basis of acceptable testing and were included in the data base.

Some of the more important chemical structures and substructures represented in the combined heterogeneous data set are shown in Table 2.

During model development 46 compounds had to be removed from the data base for various reasons: atypical structure, structure was a statistical multivariate outlier, questionable bioassay results, and such.

### ***Compound Estimation***

The SAR equation, which has the form shown below, is evaluated for the compound of interest. First, parameters for the equation are generated, then their values are entered into the equation, and, finally, the probability of carcinogenicity is calculated.

The equation takes the following form:

$$\begin{aligned} \text{Discriminant score} = & \text{Constant} + (\text{coefficient 1} \times \text{variable 1}) \\ & + (\text{coefficient 2} \times \text{variable 2}) \\ & + (\text{coefficient 3} \times \text{variable 3}) \\ & + \dots\dots\dots \\ & + (\text{coefficient N} \times \text{variable N}) \end{aligned}$$

The discriminant score is then entered into an exponential equation from which the probability is calculated.

TABLE 2. CHEMICAL GROUPS IN THE CARCINOGENICITY MODEL

Chemical Class	Carcinogenicity	
	Neg	Pos
Halogen-Containing Structures		
Chlorine	17	46
Bromine	0	5
Fluorine	4	0
Alcohols	99	8
Organic Acids	13	6
Esters	58	2
Amines		
Primary	11	37
Secondary	27	3
Tertiary	16	13
Amides		
Primary	5	0
Secondary	11	8
Tertiary	2	3
Lactams	4	0
Ureas, Guanides, etc.	7	5
Nitriles	0	1
Nitro, Nitroso Structures	2	14
Nitrosamines	2	5
Hydrazines, Hydrazides, etc.	7	9
Sulfamines	6	0
Sulfoxides	3	1
Sulfones	6	1
Sulfonates	3	1
Disulfides	1	0
Phosphorus-Containing Structures	1	5
Carbon Rings	147	64
Oxygen-Containing Rings	11	5
Nitrogen-Containing Rings	30	6
Oxygen and Nitrogen-Containing Rings	2	0
Sulfur and Nitrogen-Containing Rings	5	2
Non-C, O, N, S-Containing Rings	0	2
Miscellaneous Structures	37	0

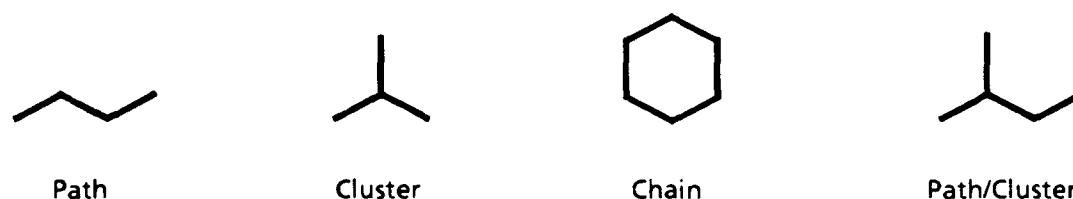


### **Estimability and Validation**

While it is always possible to calculate a discriminant score, one needs to assess the degree of confidence that can be placed in it. First, it must be determined whether the structures in the model's data base adequately cover the compound to be estimated in terms of substructures, and, secondly, the compounds in the data base which contain these substructural features must be reviewed to compare their carcinogenicity ratings with the estimated compound.

### **RESULTS**

In addition to the constant, 42 parameters were used in the model equation, 38 of which were dichotomous. The four continuous parameters included two molecular connectivity indices (MCI) [25] (see Figure 1 for examples), and two that described the longest chains of atoms in molecules and the longest paths in ring systems.



**Figure 1. Examples of MCIs.**

*DIFPAT0*, the parameter obtained as a difference in the zero-order valence and simple connectivity indices, quantifies information about heteroatoms in a molecule, while the descriptor *SUMPAT1* partially encodes overall electronic and volume characteristics of a molecule.

Table 3 shows the variables in the equation and the sign of their coefficients. A coefficient with a positive sign adds to the probability of carcinogenicity; a negative one reduces it. Within each section, the variables are ranked from most important to least important according to their power to distinguish carcinogens from noncarcinogens. Space limitations make it impractical to provide all the documentation that would be needed to interpret the coefficient values meaningfully. These values have, therefore, been omitted.

When the resubstitution method for validation was applied to the equation, the classification shown in Table 4 was obtained.

The compounds classified as indeterminates are those for which the probability of carcinogenicity was calculated to lie between  $p = 0.3$  and  $p = 0.7$ ; that is, the probabilities lie too close to chance (0.5) to be useful for a decision as to positivity or negativity.

**TABLE 3A. PARAMETERS WITH POSITIVE CONTRIBUTION TO CARCINOGENICITY IN THE MODEL EQUATION**

Description
Longest atom chain in non-ring molecule
Hydrazine
Aryl amide
Primary or secondary chlorine fragment (non-beta phenyl)
Any aliphatic bromine
Azo fragment
Aliphatic 3-branched nitrogen (non-amide)
Ring carbonyl
Aliphatic halogen
Nonaromatic ring chlorine
Benzene
Oxirane
Two benzenes linked via 4-branched carbon
Aryl amine
Aryl nitro
Number of electron releasing groups on single benzene
Summed path MCI order 1
NH substituted with one electron-releasing group and one electron-withdrawing group
N substituted with two electron-releasing groups and one electron-withdrawing group

**TABLE 3B. PARAMETERS WITH NEGATIVE CONTRIBUTION TO CARCINOGENICITY IN THE MODEL EQUATION**

Description
Saturated primary or secondary aliphatic ester (non-beta phenyl)
Longest aliphatic carbon chain in molecule
Secondary aryl amine
Methyl amine fragment
Two electron-withdrawing groups bound to NH
Aliphatic aldehyde
Aryl sulfonic acid
Two electron-releasing groups on single benzene ring (Para)
One withdrawing group and two releasing groups (1, 2, 5) on single benzene
Piperidine
Piperazine
Hetero-ring linked to benzene in no. 2 position
Dialkyl ketone
Primary aliphatic alcohol
Aryl alcohol
Aryl methoxy
Aryl aldehyde
Difference path MCI order 0
Ethane or ethylene between one releasing group and one withdrawing group
3-Carbon chain between one electron-withdrawing group and one electron-releasing group

TABLE 4. DISCRIMINANT ANALYSIS CLASSIFICATION

	ESTIMATE		
	Carcinogens	Indeterminate <sup>a</sup>	Noncarcinogens
Carcinogens	100		1
BIOASSAY		3	
Noncarcinogens	3		268
Indeterminates:	3/375 = 0.8%		
False Positives:	3/372 = 0.8% <sup>b</sup> or 3/217 = 1.1% <sup>c</sup>		
False Negatives:	1/372 = 0.3% <sup>b</sup> or 1/101 = 1.0% <sup>c</sup>		
Overall accuracy:	368/372 = 98.9%		
F = 43.0 with 43 and 331 DF			

<sup>a</sup> In the region of chance probability ( $p = 0.5 \pm 0.2$ ).

<sup>b</sup> Denominator consists of all compounds not in the indeterminate group.

<sup>c</sup> Denominator includes only negative or positive compounds, respectively.

The following compounds were falsely classified as positive.

CAS NO.	NAME
7779-77-3	Isobutyl Anthranilate
86-57-7	1-Nitronaphthalene. Except for this structure the aryl nitro entity has consistently identified carcinogens.
95-50-1	1,2-Dichlorobenzene. Aryl chlorides have consistently exerted a positive influence.

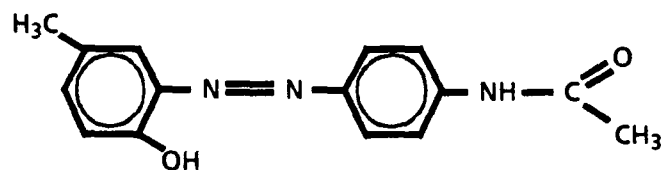
The following compound was falsely classified as a noncarcinogen.

CAS NO.	NAME
78-42-2	tris-(2-Ethylhexyl) Phosphate

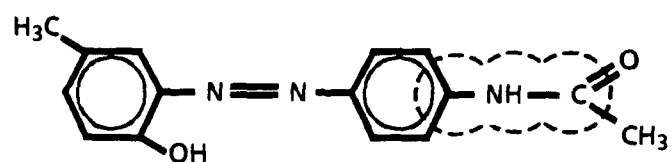
#### ESTIMATION EXAMPLE

We have chosen to use CI Disperse Yellow 3 as an example. Its structure is shown in Figure 2a.

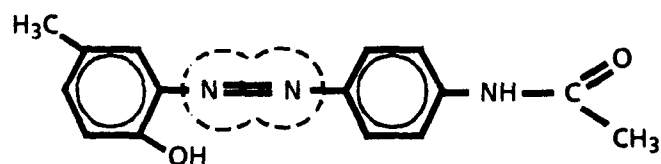
The estimation process begins with a scan of the chemical entity for substructures (keys) which are present in the carcinogenesis equation as well as in the subject chemical. These keys are shown in Figures 2b-2e. Note that while an aryl amide, an azo fragment, and such have been identified as being used in calculation of the estimate, other parts of the molecule – the methyl on the first ring and the aryl carboxylic acid – are not being used in that calculation.



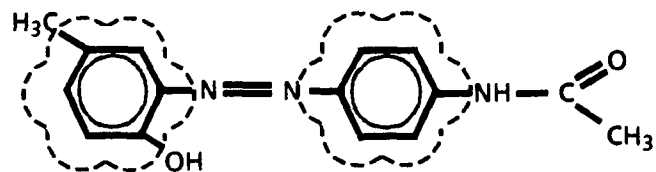
2a. CI Disperse Yellow 3



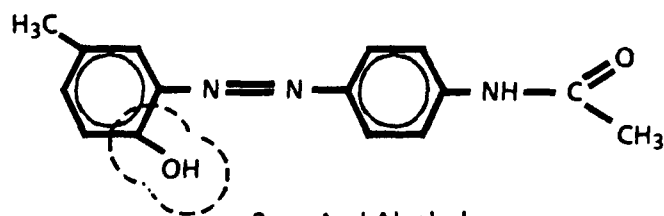
2b. Aryl Amide



2c. Azo Fragment



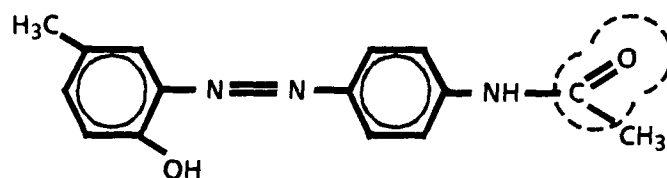
2d. Benzene



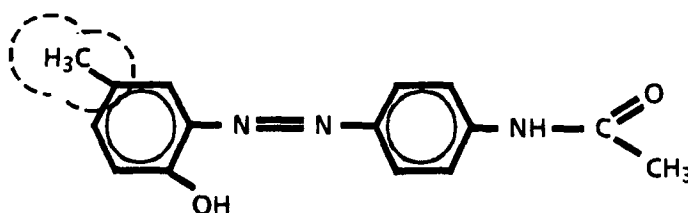
2e. Aryl Alcohol

**Figure 2a-2e.** Keys Contained in Both the Model and CI Disperse Yellow 3. These keys are used in making the estimate of carcinogenic potential.

On the basis of this information, it must be decided whether the compound is covered well enough by the compounds from which the model was constructed so that one can decide whether the estimate is useful. This question can be answered in the following way: When the equation was developed, a set of parameters was generated from the compounds in the data base. Some of these parameters were more useful than others in explaining carcinogenicity; these were used in the equation. The remaining parameters, while describing substructural aspects of the compounds in the data base, were not important enough to be included in the equation because there is a statistical incentive to limit the number of parameters in the model to a fraction of the number of compounds in the data base. These keys were sequentially searched to determine which of them also cover Cl Disperse Yellow 3. The resulting keys are shown in Figures 3a and 3b. Note that the methyl group and the carboxylic acid group are present with sufficient frequency in the compounds in the data base and, together with the keys in the equation, completely cover Disperse Yellow 3. We can, therefore, be confident that Disperse Yellow 3 is estimable by the model. The estimate is shown in Table 5.



3a. Non-Ring Carbonyl



3b. Aryl Methyl

Figure 3a-3b. Keys Not in Equation, but Providing Evidence for Coverage of Cl Disperse Yellow 3 by Chemicals in the Model Data Base.

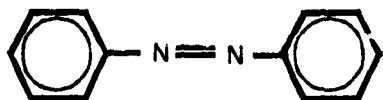
TABLE 5. CARCINOGENESIS ESTIMATE FOR DISPERSE YELLOW 3

Estimate for Positive Endpoint = 1.000	
	Cross Product
Aryl amide	11.791
Azo fragment	20.892
Longest aliphatic carbon chain in molecule	-1.290
Benzene	2.025
Aryl alcohol	-2.463
Summed path MCI order 1	7.333
Difference path MCI order 0	-7.624
Constant term	-13.573
	<u>17.092</u>

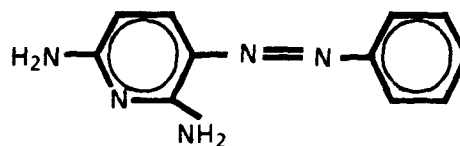
The listed parameters are used in the estimation of the probability of carcinogenicity, expressed as a p-value, if Disperse Yellow 3 were assayed in a two-year, two-species NTP testing protocol, as evaluated according to Griesemer's criteria. For the calculation of the cross-products in Table 5, the value for each parameter used for the prediction of carcinogenicity for Disperse Yellow 3 was calculated. The value for the respective parameter was multiplied by the coefficient for that parameter in the discriminant equation, resulting in the listed cross-products. A negative cross-product signifies that the corresponding parameter reduces the probability of carcinogenicity, whereas a positive cross-product increases it. We have already described above the keys used in the equation. Note that the relative importance of the parameters can be judged by the magnitude of the cross-products, the aryl amide group and the azo bond being particularly important in determining the carcinogenicity of Disperse Yellow 3.

#### ***Validation of the Estimate***

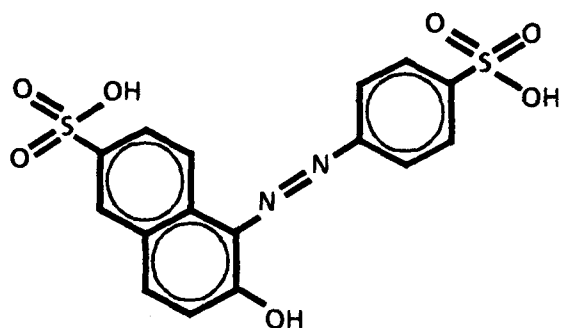
Now the data base from which the model was developed with these important parameters can be searched to determine whether compounds in the data base that have some of these above-mentioned substructural features can be used to validate the estimate. Figures 4a through 4f show the compounds in the data base that contain an azo fragment. For each compound the CAS number is displayed, as well as presence or absence of carcinogenicity, and the source of the data. For example, Figure 4a shows that azobenzene itself is a carcinogen, and that the source was the paper of Griesemer and Cueto [22]. The search for data base compounds with the azo fragment showed the following: azobenzene (Figure 4a), the parent compound of Disperse Yellow 3, is a carcinogen; phenazopyridine HCl (Figure 4b) is a carcinogen, and its carcinogenicity is probably enhanced by the amine groups on the pyridine ring; and FD & C Yellow No. 6 (Figure 4c), on the other hand, is a noncarcinogen (note that the salient differences between this compound and the prior two are the two sulfonic acid groups; the same is true for CI Acid Red 14 (Figure 4d); CI Solvent Yellow 14 (Figure 4e), on the other hand, is a carcinogen – there are no sulfonic acid groups). Finally, D&C Red No. 9 (Figure 4f) is a carcinogen; it has only one sulfonic acid group. It is interesting to examine the carcinogenicity estimate (Table 6) for this compound. As in the case of Disperse Yellow 13, the contribution of the azo fragment dominates the cross-products, but the negative coefficient for the aryl sulfonic acid entity reduces the sum of cross-products so much that the probability of carcinogenicity for D&C Red No. 9 is lower than that for Disperse Yellow 13. If another sulfonic acid group were attached to D&C Red No. 9, the sum of cross-products would be negative, and, therefore, the probability of carcinogenicity for this modified compound would be very low. It is the influence of the two sulfonic acid groups in the other dyes cited above that probably renders them noncarcinogenic.



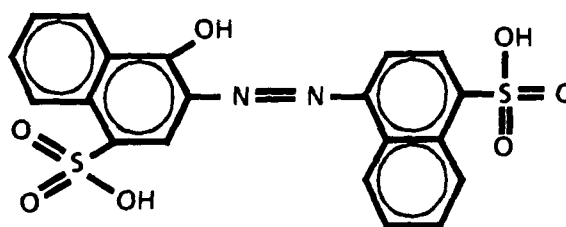
4a. Azobenzene  
CAS: 103-33-3  
Actual: Positive  
Ref.: Table 3/RPT #154



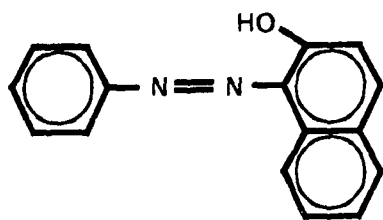
4b. Phenazopyridine Hydrochloride  
CAS: 136-40-3  
Actual: Positive  
Ref.: Table 1/RPT #99



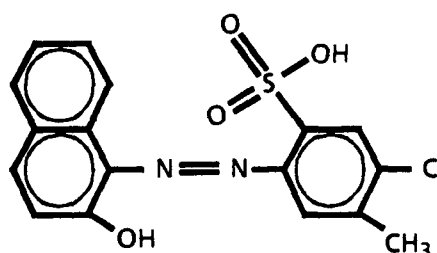
4c. FD&C Yellow No. 6  
CAS: 2783-94-0  
Actual: Negative  
Ref.: Table 9/RPT #208



4d. C.I. Acid Red 14  
CAS: 3567-69-9  
Actual: Negative  
Ref.: Table 9/RPT #220



4e. C.I. Solvent Yellow 14  
CAS: 842-07-9  
Actual: Positive  
Ref.: Table 3/RPT #226



4f. D&C Red No. 9  
CAS: 5160-02-1  
Actual: Positive  
Ref.: Table 3/RPT #225

Figure 4a-4f. Compounds in the Model Data Base Containing an Azo Fragment.

**TABLE 6. CARCINOGENESIS ESTIMATE FOR D&C RED NO. 9**

Estimate for Positive Endpoint = 0.828	
	<u>Cross Product</u>
Azo fragment	20.892
Longest aliphatic carbon chain in molecule	-1.290
Aryl sulfonic acid	-9.183
Benzene	2.025
Aryl alcohol	-2.463
Aryl chlorine	5.873
Summed path MCI order 1	9.206
Difference path MCI order 0	-9.917
Constant term	<u>-13.573</u>
	1.570

The compounds that contain the aryl amide fragment of Disperse Yellow 13 are shown in Figures 5a-5c. Note that the first two are carcinogens, but that acebutolol is not. Analysis of the estimate for this compound (Table 7) shows that the probability of it being a carcinogen is reduced by the one electron-withdrawing group and two electron-releasing groups on the benzene ring in the 1, 2, and 5 positions, and that there is a rather long aliphatic carbon chain.

One might also consider searching the data base with some of the other keys, but that search is not likely to add further information because their cross-products are so much smaller than those of the aryl amide and azo fragments. For the topological parameters, one only needs to determine whether their values are within reasonable statistical bounds of the values for the compounds in the model data base. There are only rare instances in which the MCI values are more than 2.5 standard deviations from their mean. In this particular instance, the values are well within one standard deviation, and are, therefore, acceptable.

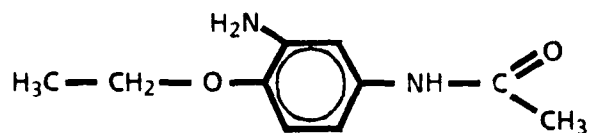
In summary, from the result of this search, one can have a relatively high level of confidence in the positive carcinogenicity estimate for Disperse Yellow 13.

## DISCUSSION

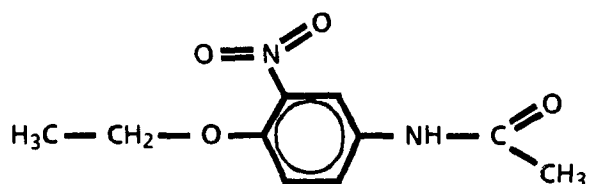
As is the case with all QSAR models, the quality of the model depends on the quality of the data used to develop it. Many compounds selected for the NCI/NTP bioassays carry a presumption of being carcinogenic, so it is unlikely that there will ever be enough noncarcinogenic results from NCI/NTP bioassays.

We believe that the list of chemicals in CFR 21 is a reasonable alternate source of putative noncarcinogens and that the inference of negativity is sufficiently reliable. The pharmaceutical compounds in the data base have all been tested under protocols identical or very nearly identical to that specified by NCI/NTP. The inclusion or exclusion of candidate parameters and certain compounds was conditioned by the need to develop equations that are useful for the prediction of the carcinogenic potential of untested compounds, rather than the elucidation of mechanisms of carcinogenesis.

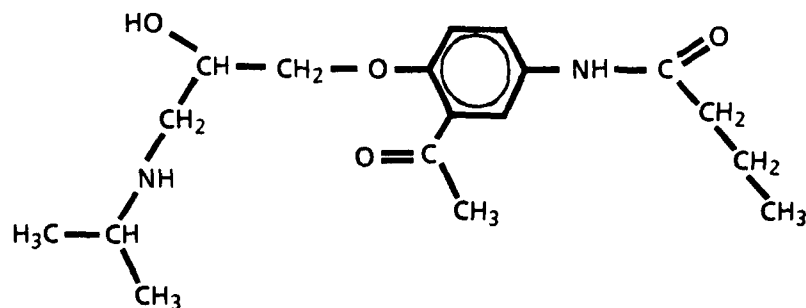




5a. 3-Amino-4-ethoxy Acetanilide  
 CAS: 17026-81-2  
 Actual: Positive  
 Ref.: Table 5/RPT #112



5b. 3-Nitro-para-acetophenetide  
 CAS: 1777-84-0  
 Actual: Positive  
 Ref.: Table 5/RPT #133



5c. Acebutolol  
 CAS: 37517-30-9  
 Actual: Negative  
 Ref.: Physician's Desk Reference

**Figure 5a-5c. Compounds in the Model Data Base Containing an Aryl Amide.**

All present QSAR models of carcinogenicity have limitations. Pairs of chemicals exist in which small structural differences make the difference between carcinogenicity and noncarcinogenicity; for

TABLE 7. CARCINOGENESIS ESTIMATE FOR ACEBUTOLOL

Estimate for Positive Endpoint = 0.001	
	<u>Cross Product</u>
Aryl amide	11.791
Longest aliphatic carbon chain in molecule	-3.871
Benzene	2.025
1 Withdrawing group and 2 releasing groups (1, 2, 5) on a single benzene	-8.485
Number of electron releasing groups on a single benzene	2.921
Summed path MCI order 1	9.192
Difference path MCI order 0	-7.581
Constant term	<u>-13.573</u>
	-7.581

example, benzo[a]pyrene/pyrene and eugenol/methyl eugenol. No QSAR equation or similar predictive system can presently be expected to deal with such special cases systematically.

When explanations for the differences in the behavior between members of such closely related pairs are discovered, one might be able to devise and incorporate parameters reflecting that knowledge in the equations. This applies particularly to parameters that portray biotransformation and pharmacokinetic factors. We currently are attempting to at least partially take into account detoxification by including keys for electron-donating and -withdrawing groups. We expect that our capability for dealing with these issues will be enhanced by the ability to calculate electronic charge distribution for whole molecules as we have done in several other SAR models [7,8] and by devising three-dimensional topological parameters to describe entire molecules as well as substructures.

The use of the model for the estimation of untested compounds should be more or less confined to the space (or variety) encompassed by the chemicals and chemical substructures of the model's data base, even though there may be a temptation to extrapolate too far outside the boundaries of that space; the search for covering substructures and similar compounds is done to counteract that temptation. For example, the model cannot be used for lactones, anhydrides, and other features that are not adequately represented in the data base.

The validation process is somewhat subjective. Complete substructural representation of a new structure by the data base is not always achieved and the judgment as to whether coverage is adequate depends at least in part on the use to which an estimate will be put. The validation of an estimate should generally be performed by someone familiar with the toxicological characteristics of the compound in question and the class to which it belongs, and also the intended use or anticipated

exposure factors. These have considerable influence on the judgment regarding the validity and usefulness of an estimate.

The directed search of the data base for pertinent structures and substructures may also serve as a guide for additional searching of the toxicological literature.

The model described above is currently being enhanced in two ways: (1) chemicals are being included that have been tested under other than the NCI/NTP protocol, and (2) relative weighting of the compounds is performed to reflect the degree of confidence in individual data points. We expect that the result will be a model applicable over a considerably wider span of chemical structures and substructures as well as one having a level of performance at least equaling the model described above.

#### REFERENCES

- 1 Enslein, K., Borgstedt, H.H., Tomb, M.E., Blake, B.W. and Hart, J.B. (1987) A structure-activity prediction model of carcinogenicity based on NCI/NTP assays and food additives. *Toxicol. Ind. Health* 3, 267-287.
- 2 Enslein, K., Blake, B.W., Tomb, M.F. and Borgstedt, H.H. (1987) Prediction of Ames test results by structure-activity relationships. *In Vitro Toxicol.* 1, 33-44.
- 3 Enslein, K., Borgstedt, H.H., Blake, B.W. and Hart, J.B. (1987) Prediction of rabbit skin irritation severity by structure-activity relationships. *In Vitro Toxicol.* 1, 129-147.
- 4 Enslein, K., Blake, B.W., Tuzzeo, T.M., Borgstedt, H.H. and Hart, J.B. (1988) Estimation of rabbit eye irritation scores by structure-activity equations. *In Vitro Toxicol.* 2, 1-14.
- 5 Enslein, K., Lander, T.R. and Strange, J.R. (1983) Teratogenesis: a statistical structure-activity model. *Terat. Carcin. Mutagen.* 3, 289-309.
- 6 Enslein, K., Lander, T.R., Tomb, M.E. and Craig, P.N. (1983) A predictive model for estimating rat oral LD50 values. In: *Benchmark Papers in Toxicology*, Princeton Scientific Publishers, Princeton, New Jersey.
- 7 Enslein, K., Tuzzeo, T.M., Blake, B.W. and Hart, J.B. (1989) Prediction of *Daphnia magna* EC50 values from rat oral structural parameters. American Society of Testing Materials (ASTM), Special Technical Publications 1007, 397-409.
- 8 Enslein, K., Tomb, M.E. and Hart, J.B. ( ) Structure-activity relationships: fathead minnow LC50 predicted from rat oral structure, and vice versa.
- 9 Enslein, K., Gombar, V.K., Blake, B.W. and Howard, P.J. (In Preparation) Biodegradation models for benzenoids and acyclic compounds.
- 10 Hansch, C. and Leo, A. (1979) *Substituent Constants for Correlation Analysis in Chemistry and Biology*. Wiley, New York.

- 11 Free, S.M. and Wilson, J.W. (1964) A mathematical contribution to structure-activity studies. *J. Med. Chem.* 1, 395-399.
- 12 Wishnok, J.S. and Archer, M.C. (1976) Structure-activity relationships in nitrosamine carcinogenesis. *Brit. J. Cancer* 33, 307-311.
- 13 Wishnok, J.S., Archer, M.C., Edelman, E.S. and Rand, W.M. (1978) Nitrosamine carcinogenicity: A quantitative Hansch-Taft structure-activity relationship. *Chem. Biol. Interact.* 20, 43-54.
- 14 Klopman, G. (1984) Artificial intelligence approach to structure-activity studies. Computer automated evaluation of biological activity of organic molecules. *J. Am. Chem. Soc.* 106, 7315-7321.
- 15 Jurs, P.C., Chou, J.T. and Yuan, M. (1979) Computer-assisted studies of chemical carcinogens: A heterogeneous data set. *J. Med. Chem.* 22, 476-483.
- 16 Yuan, M. and Jurs, P.C. (1980) Computer-assisted studies of chemical carcinogens. Polycyclic aromatic hydrocarbons. *Toxicol. Appl. Pharmacol.* 52, 294-312.
- 17 Yuta, K. and Jurs, P.C. (1981) Computer-assisted studies of chemical carcinogens. Aromatic Amines. *J. Med. Chem.* 24, 241-251.
- 18 Enslein, K. (1984) Estimation of toxicological endpoints by structure-activity relationships. *Pharmacol. Rev.* 36, 1315-1355.
- 19 National Toxicology Program. (1985) Fourth Annual Report on Carcinogens. U.S. Public Health Service. Publ. NTP 85-002. Superintendent of Documents, Washington, DC.
- 20 Griesemer, R.A. and Cueto, C. (1980) Toward a classification scheme for degrees of experimental evidence for the carcinogenicity of chemicals for animals. *IARC Scientific Publications* 27, 259-281.
- 21 IARC. (1972-ff) Evaluations of Carcinogenic Risk of Chemicals to Humans, Vols. 1-28. IARC Monographs. IARC, Geneva.
- 22 USPHS 149. (1976-1977) Survey of Compounds Which Have Been Tested for Carcinogenic Activity. NIH Publication No. 84-2631, DHHS, NCI, Bethesda, MD.
- 23 Code of Federal Regulations (U.S.), Vol. 21, Food and Drugs. (1987) Superintendent of Documents, Washington, DC.
- 24 Medical Economics. (1986) Physicians' Desk Reference. 40th ed., Oradell, New Jersey.
- 25 Kier, L.B. and Hall, L.H. (1986) *Molecular Connectivity in Structure-Activity Analysis*. Wiley, New York.

# A COMPUTER-ASSISTED PROCEDURE FOR THE ASSEMBLY AND ANALYSIS OF SHORT-TERM GENOTOXICITY TEST DATA

David Brusick

*Hazleton Laboratories of America, 9200 Leesburg Pike, Vienna, VA 22180*

## SUMMARY

Determining the genetic hazard of a chemical is generally approached by using an assortment of tests for measuring the DNA reactivity of a chemical or its resultant genotoxicity. Over 100 short-term tests employing a wide diversity of species and genetic mechanisms have been used to measure genetic hazard. To date, attempts to achieve a standard test battery for defining genetic hazard have not been successful. Consequently, testing for genetic hazard involves the use of test batteries with variable types and numbers of assays. This increases the difficulties of interpreting data sets because the data sets are often filled with inconsistent responses from diverse types of assays.

Several years ago, the International Commission for Protection Against Environmental Mutagens and Carcinogens established a committee to establish a method to compile and interpret diverse short-term test data. The Committee has produced a quantitative weight-of-evidence approach that combines test data using certain parameters such as dose, replication, and metabolic capacity into a series of scores for test type, test class, test family, and an overall score that defines the total weight-of-evidence regarding the genetic hazard of the agent. A description of the method and results from the evaluation of selected chemicals is provided.

## INTRODUCTION

Determining the genetic hazard of a chemical is generally approached by using an assortment of *in vitro* and *in vivo* tests for measuring genotoxicity. Over 100 short-term methods, encompassing a wide variety of species and genetic mechanisms, have been developed on the premise that diversity is important for thorough detection of genetic effects produced by all chemical types.

The use of multiple tests has created a difficult and controversial challenge in developing an interpretation with mixed test results. Various weight-of-evidence strategies have been devised, generally emphasizing intuitive, expert judgment to evaluate multitest data. It has been hoped for some time that the accumulation of test results would allow for machine-based or other formalized procedures to replace or de-emphasize subjectiveness.

The problems associated with developing standardized data assessment programs are compounded by the existence of large but incompletely filled data bases, and a heavy predominance of positive test results. Thus, the difficulties in interpreting short-term test data involve limitations in

both directions: a limited ability to draw inferences about the toxicity of a particular chemical using an ensemble of tests, and a limited ability to draw inferences about the properties of a particular test system using the data from an ensemble of chemicals.

Several years ago, the International Commission for Protection Against Environmental Mutagens and Carcinogens (ICPEMC) established a committee to address this situation by designing a general method to compile and interpret short-term test data. The driving principle used in this development was to combine the major parameters of testing (dose, metabolic activation, sign of response) into a single assay score which could then be pooled by test (e.g., *Salmonella* reverse mutation), by test class (e.g., bacterial mutation), and by family (e.g., *in vitro* tests) hierarchically into a composite score for a chemical. The system (a) would cope with redundant data, disagreement, and sporadically filled matrices, (b) would supply opportunities to investigate short-term test properties by chemical and by test, and (c) would have features of self-learning to improve predictive performance and internal consistency for any one of several types of genetic hazard, including genotoxicity *per se*, carcinogenicity, and possible reproductive toxicity.

The method chosen evolved from a scoring system first developed by Brusick [1]. It is a weight-of-evidence approach which has the capacity to incorporate either prior subjective judgments or analytically derived (learned) judgments. At present, the method is fully structured and contains a sizable data base of approximately 113 chemicals. A brief, preliminary description was published a few years ago [2], and manuscripts giving detailed description of the method and some beginning analytical results are in preparation [3, 4, 5]. This manuscript will provide preliminary information concerning the method and describe some early results with selected test chemicals.

## METHODS

### *The Organization of Testing Data*

Shown in Figure 1 is the hierarchical structure of how data on a single chemical would be combined and analyzed. The analysis begins using the literature entries for all available and suitable tests done with the chemical. One or more replicates (trials) of each test are scored individually and then combined into a composite test score. The test scores are pooled into class scores, and the class scores into family scores, ending with a single agent score for that chemical. The transition at each level of the hierarchy involves pooling the data as weighted averages.

A prerequisite for this hierarchical structure was a reasonable method to assign genotoxicity tests into classes and families. The ICPEMC Committee has grouped like tests together into 22 classes, and then combined the classes into two families based on whether they involve *in vitro* or *in vivo* tests. Classification for the tests currently carried in the system's software is shown in Table 1 [6].

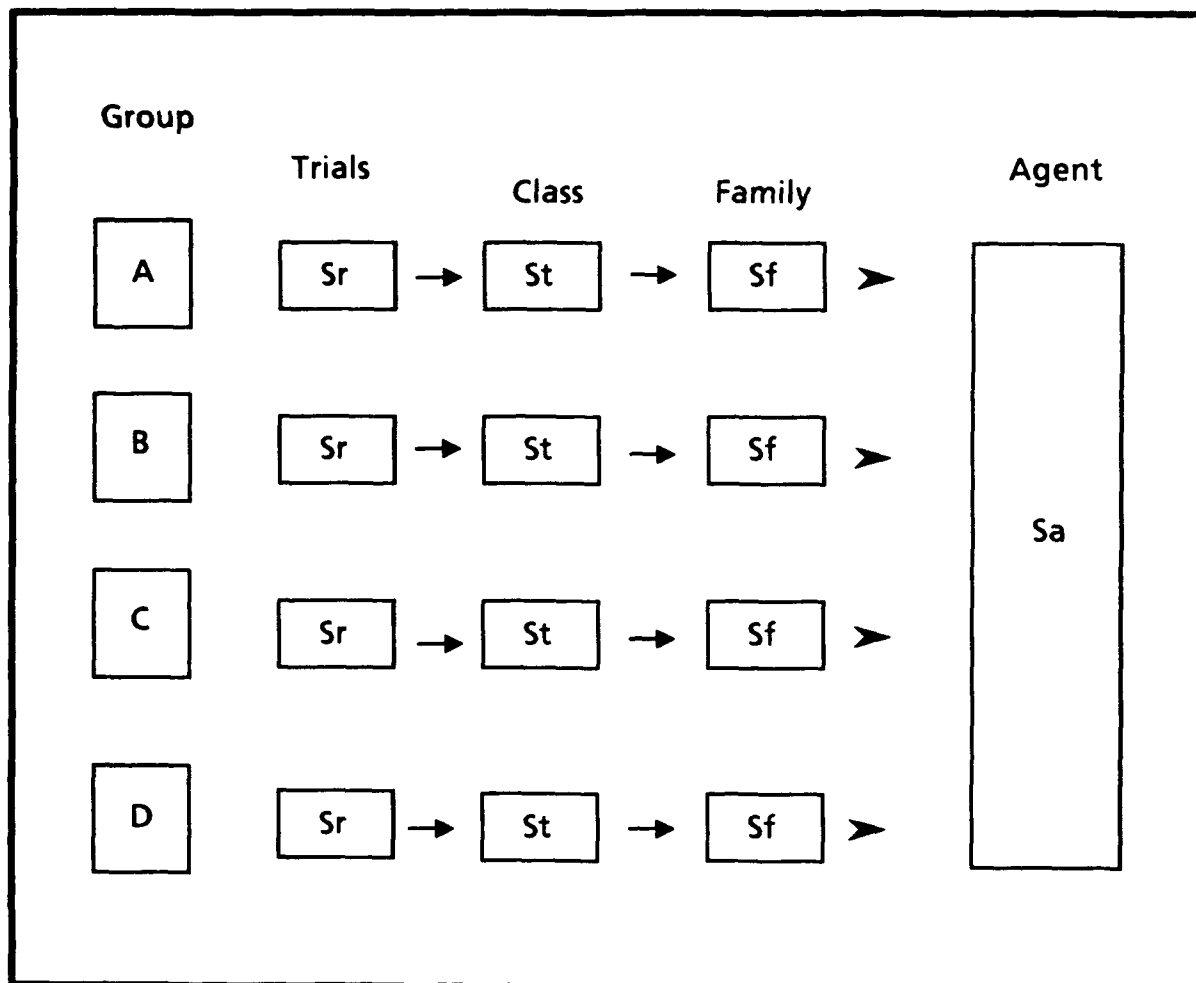


Figure 1. The General Process of Data Reduction from Individual Trials to a Single Agent Score. The merging process at each step involves weighted averaging. Each group A to D represents a broad category of test types ranging from *in vitro* assays to chronic studies in mammals.

TABLE 1. THE CURRENT FAMILY, CLASS, AND TEST STRUCTURE\*

**A. IN VITRO FAMILY**

**Class A1: Primary DNA damage – prokaryotes**

*BSD*, *Bacillus subtilis* rec strains, differential toxicity

*ECD*, *Escherichia coli* pol A/W3110-P3478 spot test, differential toxicity

*ECL*, *Escherichia coli* pol A/W3110-P3478 liquid suspension test, differential toxicity

*ERD*, *Escherichia coli* rec strains, differential toxicity

(continued)

TABLE 1. Continued

---

**Class A2: Primary DNA damage – lower eukaryotes**

*SCG*, *Saccharomyces cerevisiae*, gene conversion

*SCH*, *Saccharomyces cerevisiae*, homozygosis by recombination or gene conversion

**Class A3: Primary DNA damage – mammalian cells**

*UHF*, Unscheduled DNA synthesis in human fibroblasts *in vitro*

*UHT*, Unscheduled DNA synthesis in transformed human cells *in vitro*

*UIH*, Unscheduled DNA synthesis in other human cells *in vitro*

*UPR*, Unscheduled DNA synthesis in rat primary hepatocytes *in vitro*

*UIA*, Unscheduled DNA synthesis in other animal cells *in vitro*

**Class A4: Gene mutation – prokaryotes**

*EC2*, *Escherichia coli* WP2, reverse mutation

*ECW*, *Escherichia coli* WP2 *uvrA*, reverse mutation

*ECR*, *Escherichia coli*, miscellaneous strains, reverse mutation

*SAL*, *Salmonella typhimurium*, strains TA 1535, 1537, 1538, 98, 100

**Class A5: Gene mutation – lower eukaryotes**

*NCF*, *Neurospora crassa*, forward mutation

*NCR*, *Neurospora crassa*, reverse mutation

*SCF*, *Saccharomyces cerevisiae*, forward mutation

*SCR*, *Saccharomyces cerevisiae*, reverse mutation

*SZF*, *Schizosaccharomyces pombe*, forward mutation

*SZR*, *Schizosaccharomyces pombe*, reverse mutation

**Class A6: Gene mutation – mammalian cells**

*G5T*, Gene mutation in mouse lymphoma cells L5178Y, TK locus

*G51*, Gene mutation in mouse lymphoma cells L5178Y, other loci

*GML*, Gene mutation in mouse lymphoma cells other than L5178Y

*G9H*, Gene mutation in Chinese hamster lung cells V-79, HPRT

*G90*, Gene mutation in Chinese hamster lung cells V-79, ouabain

*GCL*, Gene mutation in Chinese hamster lung cells other than V-79

*GCO*, Gene mutation in Chinese hamster ovary cells

*GIA*, Gene mutation in other animal cells

(continued)



TABLE 1. Continued

---

**Class A7: Aneuploidy – lower eukaryotes**

*NCN*, *Neurospora crassa*, aneuploidy

*SCN*, *Saccharomyces cerevisiae*, aneuploidy

**Class A8: Sister chromatid exchange – mammalian cells**

*SHF*, Sister chromatid exchange in human fibroblasts

*SHL*, Sister chromatid exchange in human lymphocytes

*S'H*, Sister chromatid exchange in other human cells

*SIC*, Sister chromatid exchange in Chinese hamster cells

*SIA*, Sister chromatid exchange in other animal cells

*SIT*, Sister chromatid exchange in transformed cells

**Class A9: Chromosome aberration – mammalian cells**

*CHL*, Chromosome aberration in human lymphocytes

*CIC*, Chromosome aberration in Chinese hamster cells

*CIS*, Chromosome aberration in Syrian hamster embryo cells

*CAL*, Chromosome aberration in animal leukocytes

*CIA*, Chromosome aberration in other animal cells

*CIT*, Chromosome aberration in tumor cells

**Class A10: Transformation – mammalian cells**

*TBM*, Transformation in BALB/C3T3 mouse cells

*T7R*, Transformation in SA7/rat cells

*TRR*, Transformation in RLV/FISCHER rat embryo cells

*T7S*, Transformation in SA7/SHE cells

*TCM*, Transformation in Syrian hamster embryo cells, clonal assay

*TFS*, Transformation in Syrian hamster embryo cells, focus assay

*TCL*, Transformation in other established cell lines

**B: IN VIVO FAMILY**

**Class B1: DNA repair, somatic – mammal**

*UVH*, Unscheduled DNA synthesis in humans

*UVC*, Unscheduled DNA synthesis in hamsters

*UVM*, Unscheduled DNA synthesis in mice

*UVR*, Unscheduled DNA synthesis in rats

*UVA*, Unscheduled DNA synthesis in other animals

(continued)

TABLE 1. Continued

---

**Class B2: Gene mutation, somatic – insect, *Drosophila***

*DMM, Drosophila melanogaster, somatic mutation*

**Class B3: Spot test, somatic – mammal**

*MST, Spot test, mouse*

**Class B4: Sister chromatid exchange, somatic – mammal**

*SVH, Sister chromatid exchange in humans*

*SVA, Sister chromatid exchange in animals*

**Class B5: Micronucleic, somatic – mammal**

*MVC, Micronucleus test in hamsters*

*MVM, Micronucleus test in mice*

*MVR, Micronucleus test in rats*

*MVA, Micronucleus test in other animals*

**Class B6: Chromosome aberration, somatic – mammal**

*CBH, Chromosome aberration in humans, bone marrow*

*CLH, Chromosome aberration in humans, lymphocytes*

*CVH, Chromosome aberration in humans, other cells*

*CBA, Chromosome aberration in other animals, bone marrow*

*CLA, Chromosome aberration in other animals, leukocytes*

*CVA, Chromosome aberration in other animals, other cells*

**Class B7: Heritable damage – insect, *Drosophila***

*DMH, Drosophila melanogaster, heritable translocation test*

*DML, Drosophila melanogaster, dominant lethal test*

*DMX, Drosophila melanogaster, sex-linked recessive lethal test*

**Class B8: Heritable specific locus test – mammal**

*SLO, Specific locus test, mouse, other stages*

*SLP, Specific locus test, mouse, postspematogonia*

**Class B9: Dominant lethal – mammal**

*DLM, Dominant lethal test in mice*

*DLR, Dominant lethal test in rats*

(continued)

TABLE 1. Continued

---

**Class B10: Heritable translocation – mammal**

*MHT*, Heritable translocation test in mice

**Class B11: Chromosome aberration, germinal – mammal**

*CCC*, Chromosome aberration in spermatocytes, treated and observed

*CGC*, Chromosome aberration in spermatogonia treated, spermatocytes observed

*CGG*, Chromosome aberration in spermatogonia, treated and observed

*COE*, Chromosome aberration in oocytes or embryos

**Class B12: Sperm morphology – mammal**

*SPH*, Sperm morphology in humans

*SPF*, Sperm morphology in F<sub>1</sub> mice

*SPM*, Sperm morphology in other mice

*SPR*, Sperm morphology in rats

*SPS*, Sperm morphology in sheep

---

\* Code names according to Waters et. al., 1987 [6]

Presently the minimal criteria for compound entry into the analysis is that the chemical must have tests from Table 1, carried out by conventional methods, and representing at least three *in vitro* and two *in vivo* classes. These criteria, the tests listed, and the aggregation structure can be readily adjusted to meet future developments and needs.

**Data Entry and Coding**

The data input involves easily acquired test information such as test name or code, limiting doses (lowest effective dose for positive agents or highest noneffective dose for negatives), response (+ or -), use of metabolic activation (*in vitro* tests), evidence for target site localization (i.e., did dosed material reach the target tissue?) of the test agent (*in vivo*), and the reference citation. Additional factors for test replication also included in these data are entered into a specially designed computer system which files the data and does all of the processing.

Two software programs are available. The initial program was written for a Digital VAX 750 computer. A version of the VAX program has been written for IBM/AT-compatible personal computers (requiring 640 Kb of memory, a hard disk of 20 Mb minimum, and graphics capability).

### **Calculations**

The method of coalescing the data preserves the effects of data volume and judgmental modifiers by using weighted averaging. This is accomplished by carrying two parallel series of values: (1) an ENTRY value which can be summed or averaged and includes weighting by modifiers; and (2) a SCORE which has the weights removed and falls on a consistent scale from + 100% to -100%. Thus, each level of analysis (i.e., replicate, test, class, and family) has its own ENTRY, SCORE, and weight.

Two additional modifiers are used in the first two levels of data pooling: (1) The replication modifier which modestly increases the weight of test scores based on how many replicate values are available, and (2) the multiplicity modifier which weights the class score by the number of tests present. This strategy recognizes the advantage of more than one independent score of data while avoiding excessive weighting due to over-representation of one test type. It is important to realize that the system continues to average the data even when the modifiers have reached their saturation value.

The circular diagram shown in Figure 2 displays the scores for cyclophosphamide by replicate (–) and test ( $\Delta$ ), and is organized by class and family. The center of the circles represents a SCORE of -100%, the first circle is zero, and the second circle is + 100%. Test codes and class numbers are on the outside. Where data are sufficient, the standard deviation of test scores are displayed as radial lines.

The second presentation used by this system eliminates test detail to provide more of an overview of the results. It summarizes the class ( $\square$ ), family (x) and agent scores ( $\Delta$ ) and is shown as the rectangular portion of Figure 2. The vertical bars are standard deviations. The numbers on the X axis represent classes with data.

The example shown in Figure 2 represents the ICPEMC assessment of cyclophosphamide. The graphics format shown is produced from the personal computer program. The software simultaneously prints out reference citations and all calculations used in calculating each score found on the plot.

### **Reading the Plot**

A primary datum is the result from a single test on a single agent as published in a single report. The method converts this datum into an ENTRY value ( $E_r$ ), which is the product of the relevant factors and the primary modifier. Its weight ( $W_r$ ) is  $M_p$ , the primary modifier. Its SCORE ( $S_r$ ) is  $100 * E_r / W_r$  and is identified in the circular diagram as a (–).

ENTRY values for replicates of the same test are summed and an  $E_t$  value is calculated by multiplying the sum by the replication modifier ( $M_r$ ) and dividing it by the number of replicates. The weight ( $W_t$ ) is  $M_r * W_r$ , and the SCORE is  $100 * E_t / W_t$ . This test score is identified in the circular diagram

Date : 3/13/1989    Chemical = CYCLOPHOSPHAMIDE  
 Cas number = 50-18-0  
 Matrix = 1

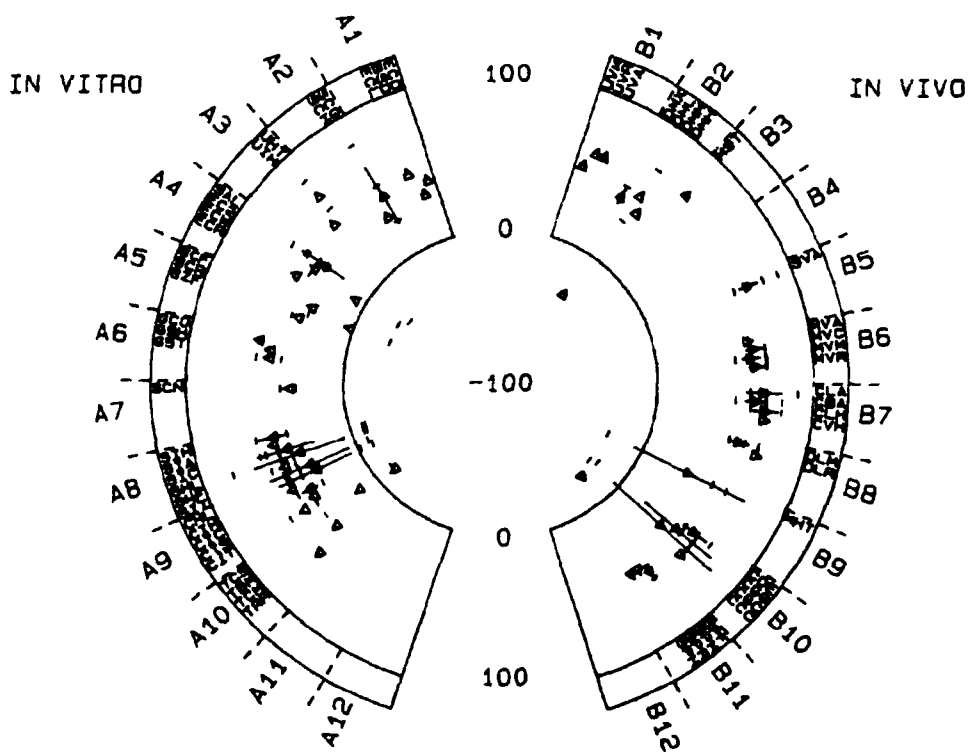
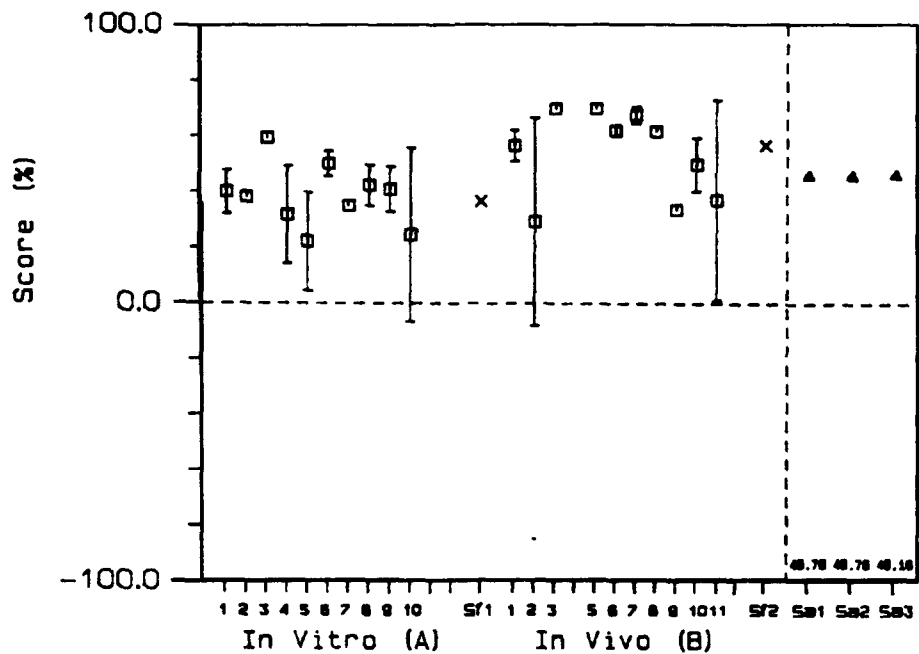


Figure 2. ICPEMC Scoring Plot, or Diagram, Displaying the Results for Cyclophosphamide. The upper portion gives test scores and the lower portion gives class, family, and agent scores.

by ( $\Delta$ ). The same process occurs to combine tests into classes, this time introducing the multiplicity modifier. Class scores are shown by ( $\square$ ) in the rectangular diagram. The family ENTRY is a weighted average of the class. They are shown as (x) in the rectangular diagram. Three versions of agent SCORE (Sa) are calculated: the first, Sa1, follows the overall pattern and is a weighted average of family ENTRIES; the second, Sa2, uses a weighted average of all of the class ENTRIES; and the third, Sa3, uses a simple average of the average class SCORE for each family. The three agent SCORES, shown as ( $\Delta$ ) to the right side of the rectangular diagram, represent a descending sequence of weighting, with Sa1 preserving the emphases supplied by the data and the prior judgments, and Sa3 treating each class equally (i.e., without class weights) regardless of any imbalance in the amount of data.

The agent scores represent the quantitative weight-of-evidence determining the degree of genetic activity identified for the test chemical by the results of the test battery.

Several additional examples for chemicals are shown in Figures 3-8. The examples include the following.

- Figure 3: benzene - a chemical extensively tested *in vitro* and *in vivo* with selective responsiveness for *in vivo* assays
- Figure 4: atrazine - a triazine herbicide which shows predominantly negative responses with a few positive responses *in vivo*
- Figure 5: dimethylcarbamoyl choride - a compound tested extensively *in vitro* with primarily, but not exclusively, positive responses
- Figure 6: chloroform - this chemical is generally regarded as nongenotoxic based on both *in vitro* and *in vivo* studies and shows a very consistent profile
- Figure 7: sodium saccharin - results show some positive effects *in vitro* but most *in vivo* studies have been negative
- Figure 8: dieldrin - an insecticide with a limited data base

The sample illustrates the diversity of the data sets generally associated with chemicals evaluated for their genotoxicity. The scoring system can be used to make activity comparisons of such compounds because of its data reduction and interpretation features. Most standardized evaluation systems require the agents being compared to have similar data sets.

At the present time, there has been no specific interpretation regarding the numerical value of the Sa. As the system evolves, it is likely that quantitative hazard concerns will be triggered by Sa.

## RESULTS

The attributes of this method of data assembly and analysis are as follows.

- All test data, both positive and negative, are used to estimate the genetic activity of the evaluated chemical. The diagrams and backup calculations permit one to see the contribution of a test, test class, or test family on the final score.

- Individual test performance relative to other individual tests or aggregate tests can be evaluated for a chemical or chemical class.
- The system requires both *in vitro* and *in vivo* entries to assess the genetic activity of chemicals. This provides a balance for chemicals that might over- or under-respond in one test type.
- The ICPEMC diagrams provide a convenient mechanism to view large numbers of responses from heterogeneous tests.
- The approach permits one to compare the genetic activity among chemicals evaluated by different ensembles of tests, or to rank order a series of chemicals.
- Information gained as the result of analyzing large data bases can be used to improve the performance of the program by adjusting or weighting factors used in calculating the scores. The system described has already been modified to improve its performance [4].

Initially, it is expected that the ICPEMC method will be useful in retrospective analysis of heavily tested chemicals with mixed responses. Manuscripts in preparation will assess the total data base of 113 compounds and outline information already learned from statistical analyses of test performance. Concerns have been expressed regarding the scientific validity of reducing complex data sets to a single weight-of-evidence score. There may also be situations where critical test results are reduced in importance by an averaging process that dilutes their impact on the final score.

The ICPEMC Committee believes that these concerns can be eliminated through validation of the approach and by judicious use of the scores generated. The potential value of this method appears to outweigh the possible limitations.

## DISCUSSION

In spite of the early stage of data analysis, it should be clear that this method is capable of meeting the initial requirements for data evaluation. The scoring system combines many of the parameters of genetic testing into a single continuous score. It is already coping with the multitudinous problems of redundant, disparate, and missing data in the genotoxicity literature. Yet to be analyzed, but already present in the system, is the capacity to evaluate test, class, and family results on the basis of test conformity and the underlying replication error in the data. The performance of classes also can be extended down to the test level with the option of weighting the tests for their relative value within classes. Another capacity that can be invoked is the ability to set or reset factors and weights used in the calculations based on actual performance in the system. This self-learning, with the possibility of discovering new underlying relationships in the genotoxicity data bases, may become the most valuable aspect of the new method [4].

At this stage in its evolution, this data base and method of analysis is already able to contribute to significant research questions and to the evaluation of specific chemicals. It should greatly increase in power as the data base is expanded, experience with the analyses is used to modify the program,

Date : 3/13/1989    Chemical = BENZENE  
 Cas number = 71-43-2  
 Matrix = 1

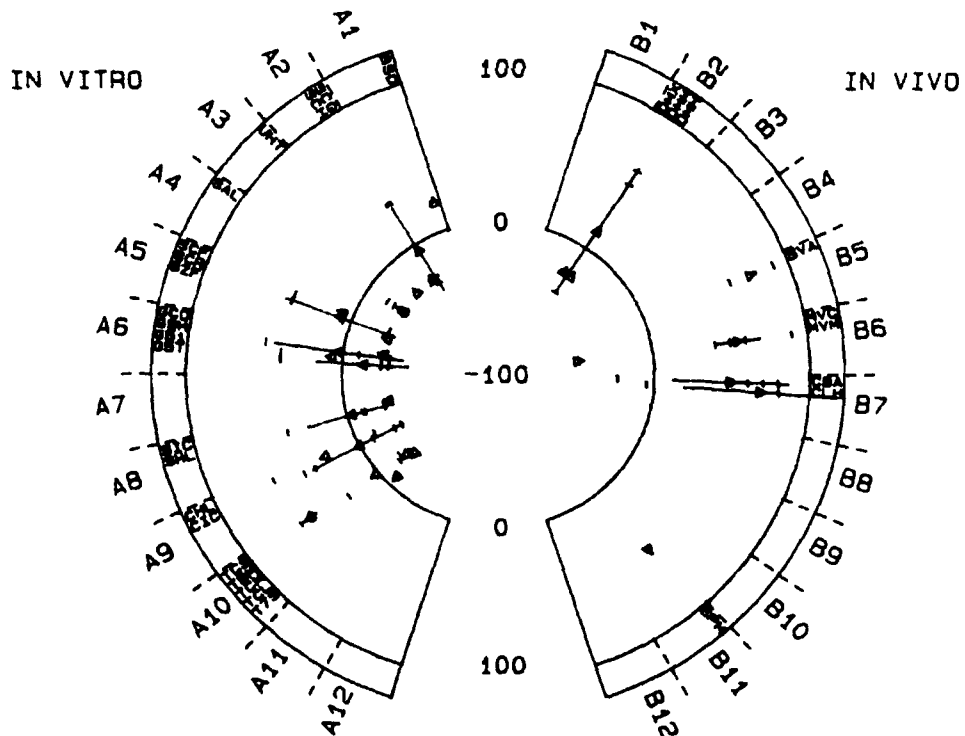
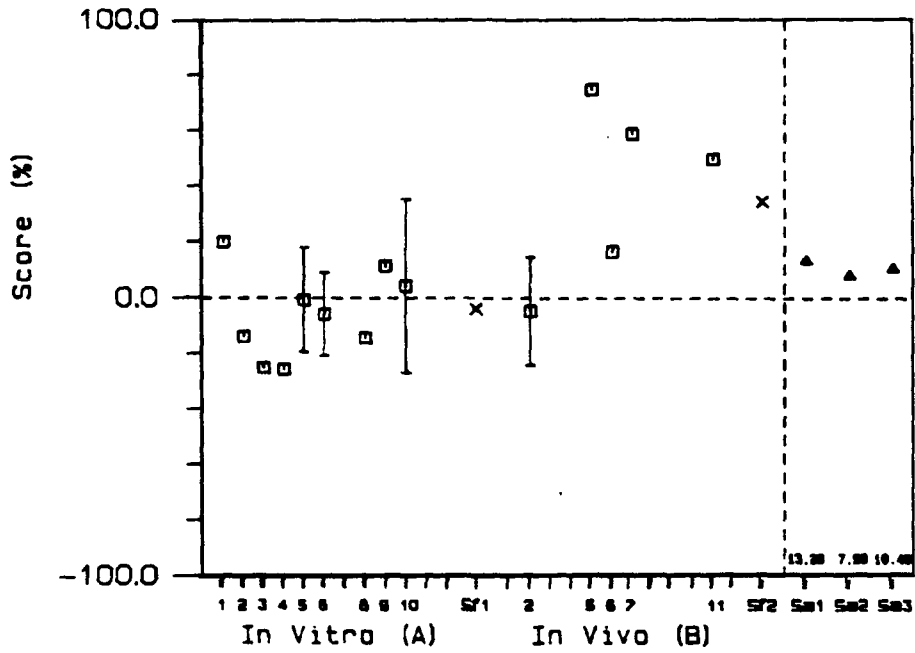


Figure 3. ICPEMC Scoring Plot Displaying the Results for Benzene.



Date : 12/13/1987 Chemical = ATRAZINE  
 Gas number = 1912249  
 Matrix = 3

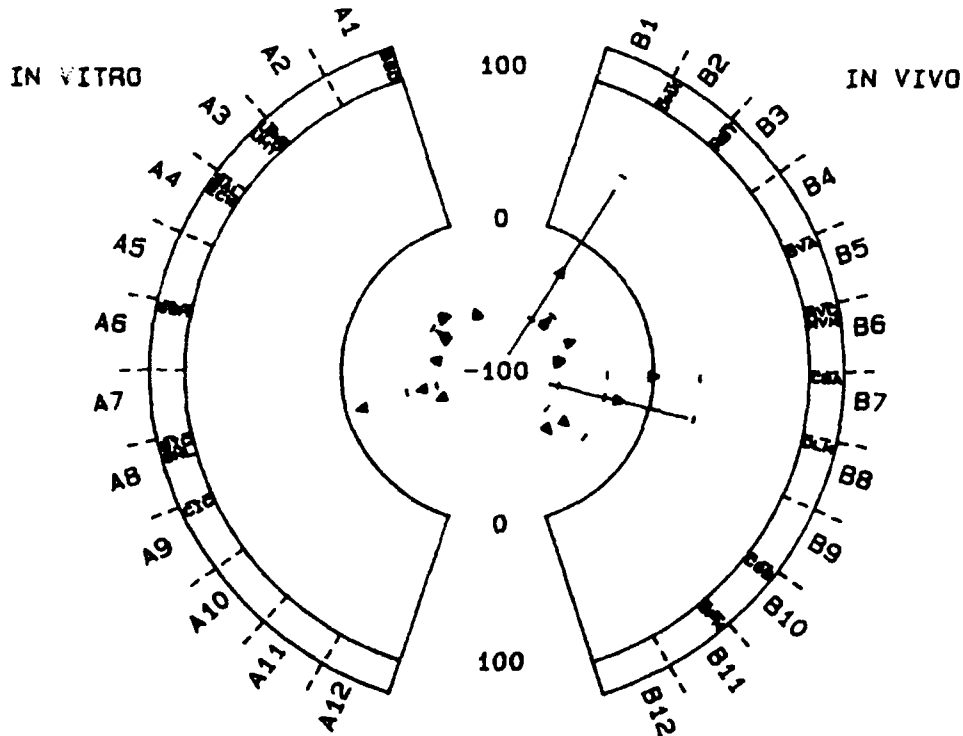
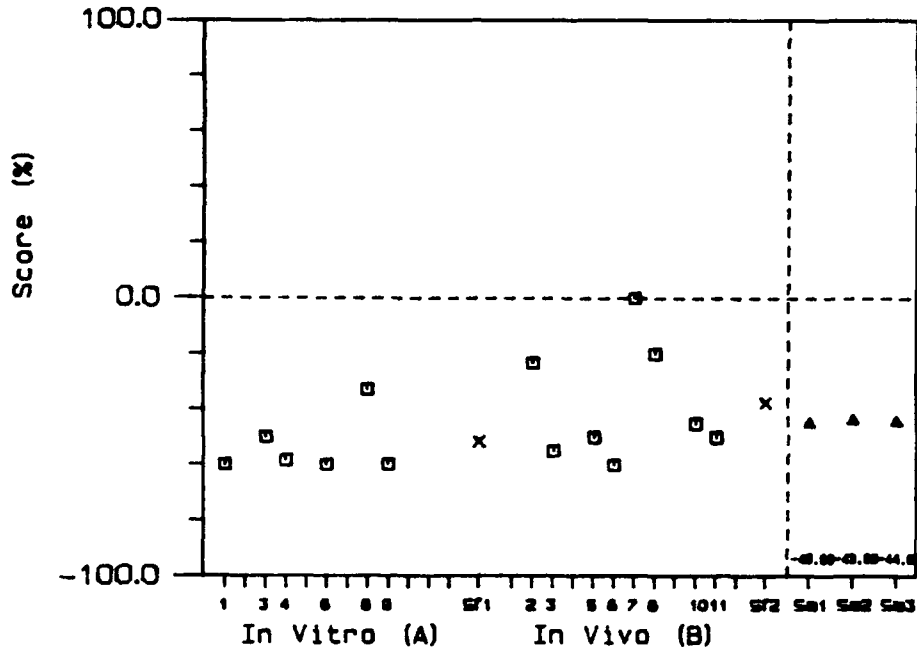


Figure 4. ICPEMC Scoring Plot Displaying the Result for Atrazine.

Date : 3/13/1989 Chemical = DIMETHYLCARBAMOYL CHLORIDE  
 Cas number = 79-44-7  
 Matrix = 1

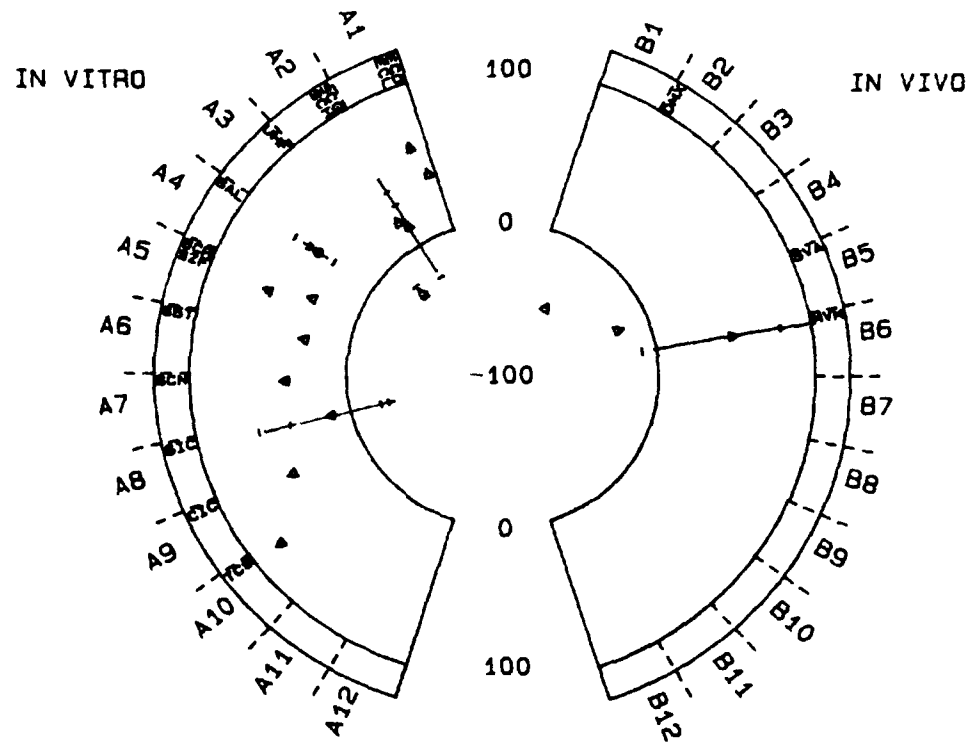
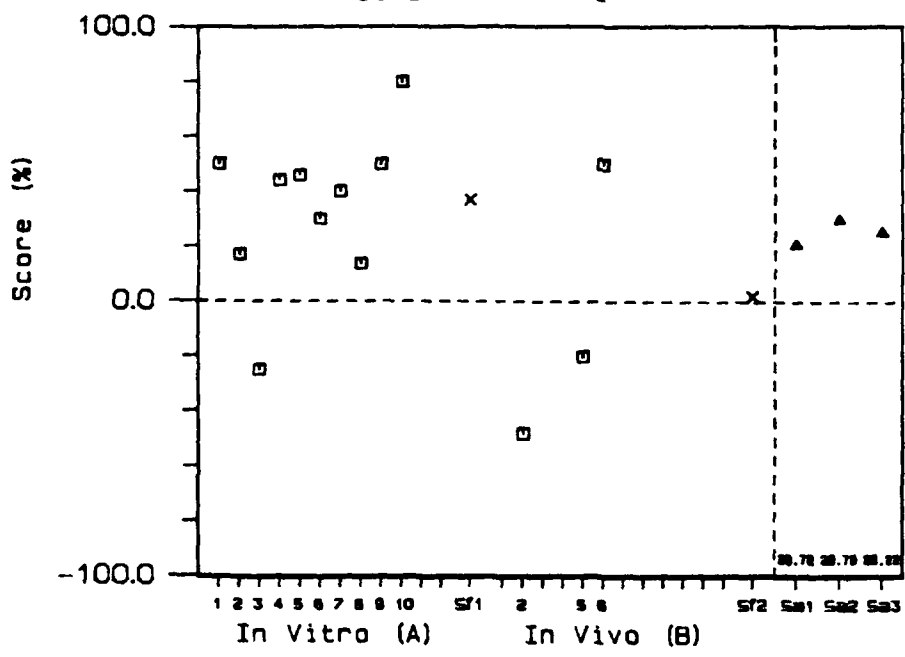


Figure 5. ICPEMC Scoring Plot Displaying the Results for Dimethylcarbamoyl Chloride.

Date : 3/13/1989    Chemical    = CHLOROFORM  
 Cas number    = 67-66-3  
 Matrix        = 1

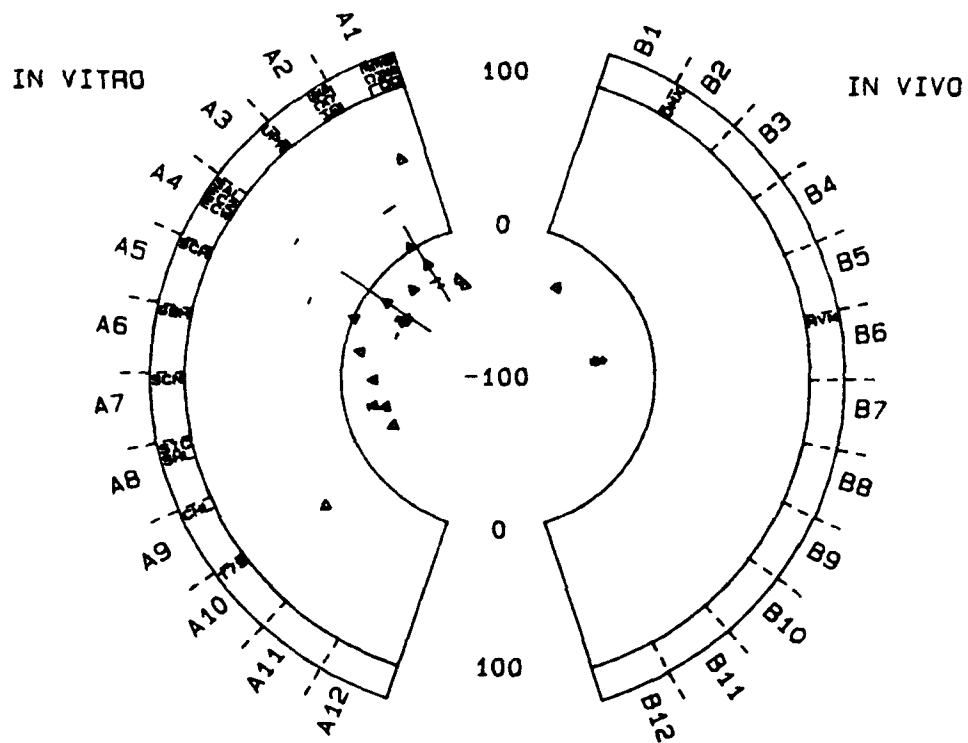
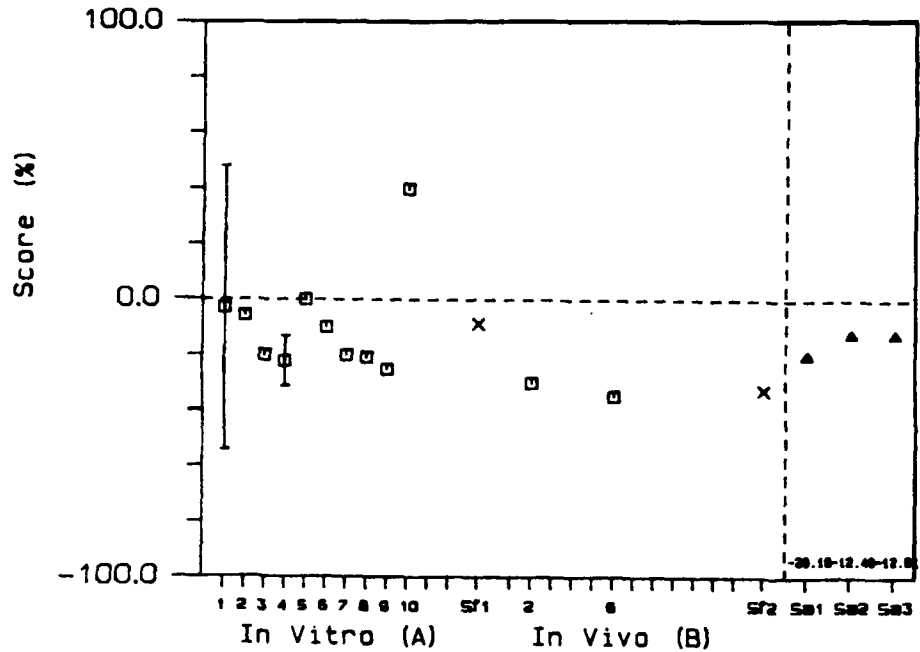


Figure 6. ICPEMC Scoring Plot Displaying the Results for Chloroform.

Date : 3/13/1989 Chemical = SACCHARIN  
 Cas number = 81-07-2  
 Matrix = 1

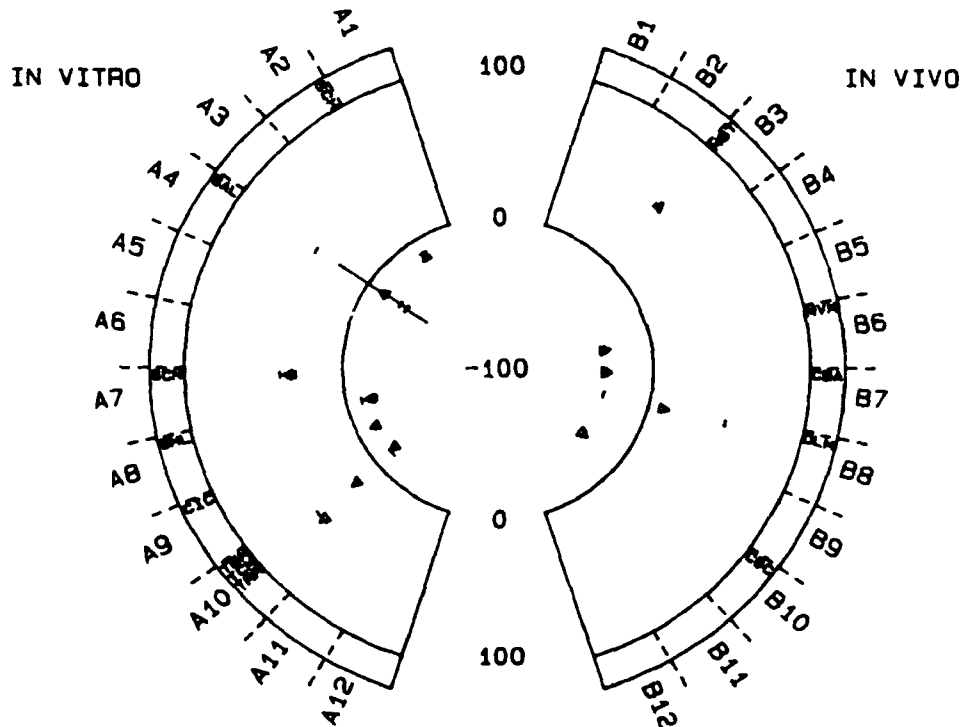
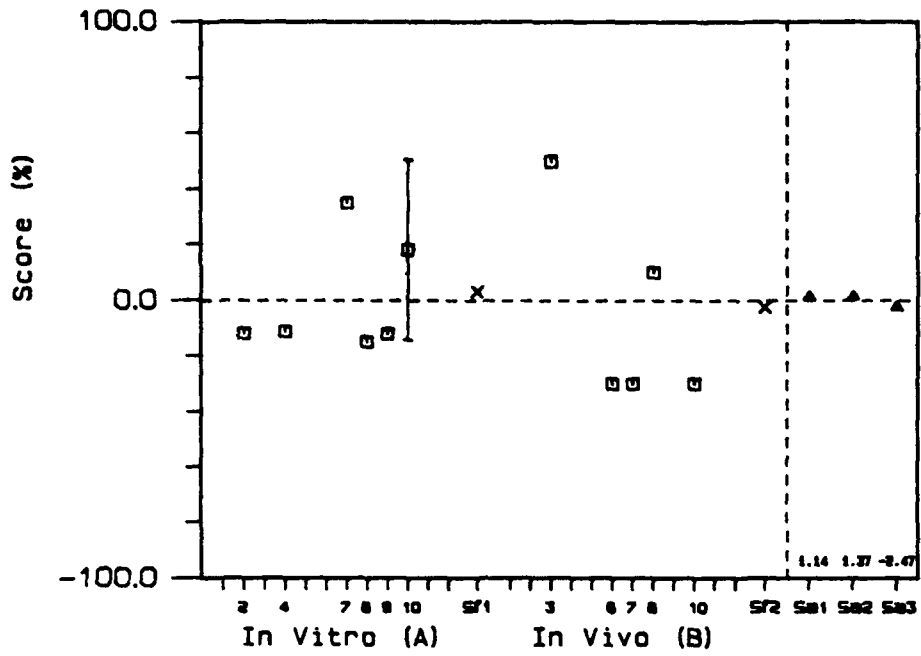


Figure 7. ICPEMC Scoring Plot Displaying the Results for Sodium Saccharin.

Date : 3/13/1989    Chemical = DIELDRIN  
 Cas number = 60-57-1  
 Matrix = 1

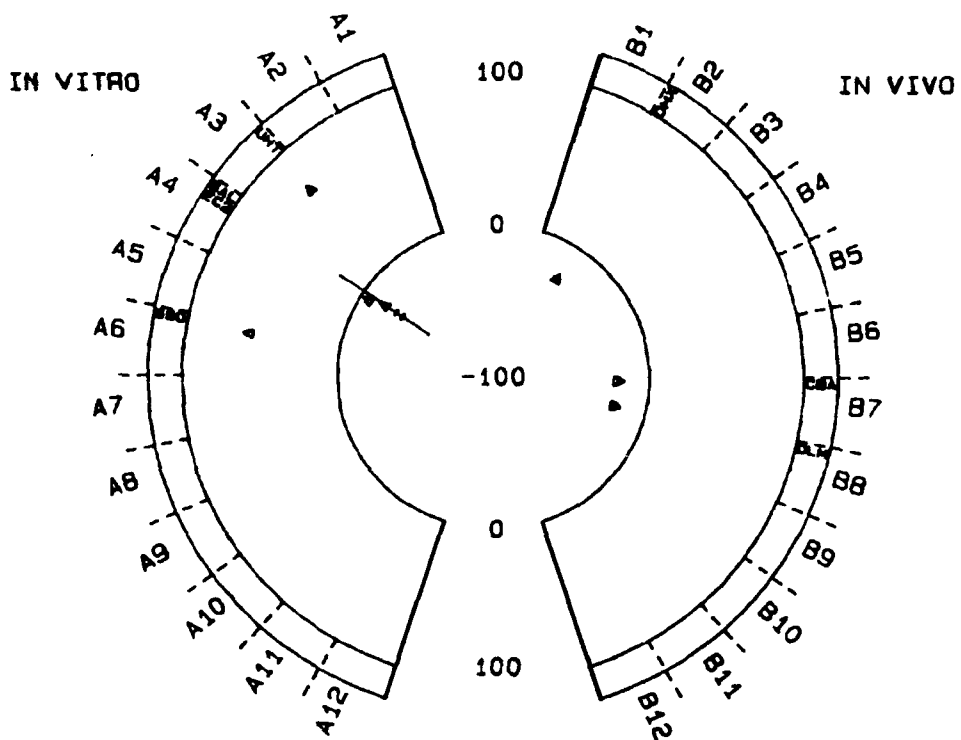
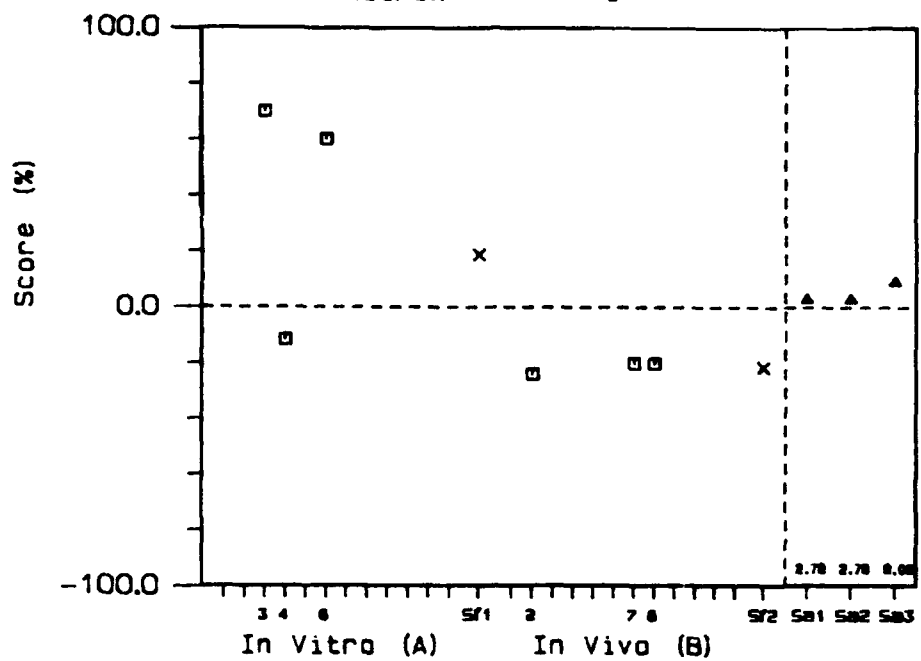


Figure 8. ICPEMC Scoring Plot Displaying the Results for Dieldrin.

and self-learning is invoked. To promote this evolution, the Committee intends to examine the role of all of the factors built into the program and will be testing whether or not tuning particular weights or combinations of weights can improve internal consistency, relationship to carcinogenicity, or relationship to heritable mutagenicity.

A crucial element in studying the relationship to carcinogenicity is the parallel development and near completion by ICPEMC of a data base and scoring system for animal carcinogenicity [7]. As the mutagenicity and carcinogenicity systems evolve, they will be compared, evaluated for how well they interrelate, and tuned one against the other.

It will be some time before anyone can say whether this approach can break through the current impasse encountered in using genotoxicity tests to predict carcinogenicity. From our initial experiences with the data, it seems clear that there will be several important new insights about tests and test batteries as a result of this method of analysis, so that even if there is not a breakthrough, there should be substantial improvement in defining relative genetic activity.

#### **ACKNOWLEDGMENTS**

The author would like to acknowledge ICPEMC for its support of the Committee's work and to the other members of the Committee, Paul Lohman, Mort Mendelsohn, Mike Waters, and John Ashby.

#### **REFERENCES**

- 1 Brusick, D. (1981) Unified scoring system and activity definitions for results from *in vitro* and submammalian mutagenesis test batteries. In: E.D. Copanhaven, C.R. Richmond, and P.J. Walsh (Eds.), Health Risk Analysis, Franklin Institute Press, Philadelphia, pp. 273-286
- 2 Brusick, D., Ashby, J., deSerres, F., Lohman, P., Matsushima, T., Matter, B., Mendelsohn, M.L. and Waters, M. (1986) Weight-of-evidence scheme for evaluation and interpretation of short-term results. In: C. Ramel, B. Lambert, and J. Magnusson (eds.), Progress in Clinical and Biological Research, vol. 209B, Proceedings of the Fourth International Conference on Environmental Mutagens, Alan R. Liss, Inc., New York, pp. 121-129.
- 3 Brusick, D., Ashby, J., deSerres, F., Lohman, P., Matsushima, T., Matter, B., Mendelsohn, M. and Waters, M. (In Preparation) A method for combining, comparing, and interpreting short-term genotoxicity test data: I. An Introduction.
- 4 Mendelsohn, M., Lohman, P. and Moore, D. (In Preparation) A method for combining, comparing, and interpreting short-term genotoxicity test data: II. Analysis of a select database.
- 5 Brusick, D., Ashby, J., Lohman, P., Mendelsohn, M. and Waters, M. (In Preparation) III. Evaluation of 113 chemicals for genetic activity.

- 6 Waters, M.D., Stack, H.F., Brady, A.L., Lohman, P.H.M., Haroun, L. and Vanio, H. (1987) Use of computerized data listings and activity profiles of genetic and related effects in the review of 195 compounds. *Mutat. Res.*, 205: 295-312.
- 7 Nesnow, S. (In Preparation) A multi-factor carcinogen potency ranking scale for comparing the activity of chemicals.

## IMPROVING TOXICOLOGY TESTING PROTOCOLS USING COMPUTER SIMULATIONS

Harvey J. Clewell, III and Melvin E. Andersen

*Toxic Hazards Division, Harry G. Armstrong Aerospace Medical Research Laboratory  
Wright-Patterson Air Force Base, OH 45433-6573*

### SUMMARY

Computer simulation can be used to integrate existing toxicity information within a biologically realistic framework. Simulation models calculate relevant measures of target tissue dose based on physiological, biochemical, and physicochemical properties and readily support the dose, route, species, and interchemical extrapolations necessary for human risk assessment. Because these models require very specific information, much of which can be obtained *in vitro*, they are much less dependent on extensive animal experiments than conventional risk assessment methods. With continuing development, simulation modeling will become an invaluable tool for improving experimental designs, for interpreting animal toxicity tests, and for estimating the importance of the animal toxicity observations for people.

### INTRODUCTION

The goal of most toxicity testing is to estimate human risk from animal test results. Tests that examine toxicity without obtaining estimates of target tissue dose are relatively useless for human risk assessment. These tests are difficult to extrapolate because *a priori* the toxicologist has no idea of the relationship between applied dose (amount in stomach or concentration in inspired air) and the relevant measure of active chemical at the target tissue(s). Additionally, he or she has no idea of how dose, route, and species differences change the relationship between applied dose and target tissue dose. Of much greater value are tests that provide quantitative information on both toxicity and on the physiological and biochemical factors in the animal that determine target tissue dose under the conditions of the tests [1-3]. When both types of data are available, computer simulation of target tissue dose within the framework of biologically based models for chemical disposition becomes a versatile tool for rapidly examining the expected consequences of a wide variety of exposure scenarios and for enhancing experimental design.

Simulation is the process of developing a mathematical description of particular events in which the individual elements involved in the overall physical or biological process are described as realistically as possible [4]. For tissue dose simulation this entails providing an accurate model of the mammalian system with respect to organ volumes, blood flows, and the anatomical relation of one set of tissues with another [5]. Next, properties of the chemical have to be introduced accurately into



the simulation model. These include tissue solubilities; biochemical pathways of metabolism in particular tissues; disposition of metabolites to urine, feces and exhaled air; and tissue binding characteristics for the test chemical. The complexity of a particular tissue dose simulation model will vary depending on the endpoints that are to be calculated and used for extrapolation among the various test and target species [6].

This paper enumerates the advantages of timely simulation modeling for improving the toxicity testing of inhaled vapors, halogenated dibenzo-*p*-dioxins, and chlorotrifluoroethylene (CTFE) oligomers. Simulation pinpoints important parameters for further study, highlights the need for limited *in vitro* studies to complete data acquisition without use of large numbers of animals for second-tier toxicity testing, and clearly outlines the data needs in primate and human tissues that will be essential to completing the extrapolation process.

### ***Inhaled Vapors***

Very simple, but nonetheless very useful, physiologically based pharmacokinetic (PB-PK) models have been used to describe the kinetics of vapors and their metabolites in rodents and other species. Ramsey and Andersen [7] developed a PB-PK model for styrene which had liver, fat, visceral, and muscle/skin compartments. The lung equilibrated vapor between end alveolar air and arterial blood, and metabolism occurred in the liver. Subsequently, this basic description has been extended for methylene chloride to account for blood concentrations of metabolites [8] and for carbon tetrachloride to account for fecal, urinary and breath elimination of metabolites [9]. Simulation models have also been developed for ethylene dichloride [10], tetrachloroethylene [11], and 1,1-dichloroethylene [12].

The development of these biologically structured models has had a dramatic impact on the methodologies involved in determining pharmacokinetic behavior and in calculating tissue dose. In early studies with styrene, and unfortunately to a large extent even today with other chemicals, the approach to kinetic studies with these vapors was first to expose large numbers of animals to the vapor and to kill groups of animals at time intervals chosen for the experimenter's convenience or on the basis of inarticulated intuition. The resulting data were then fit to a nonstructural compartmental model to give rise to mathematical forms that accurately represented the behavior of the chemical under the test conditions, but were unable to predict behavior at different concentrations in the same species [13] or in other species [14].

PB-PK models, however, are fundamentally different. In these descriptions, kinetic behavior is not some intrinsic property of the system that can be assessed only by direct experimentation. It is a macroscopic system behavior, determined by more fundamental physiological and biochemical processes. With vapors, disposition in blood and tissues is controlled by a remarkably small number of

factors: tissue volumes, blood and air flows, partition coefficients (i.e., tissue solubilities), and kinetic characteristics of the metabolizing enzymes. Most importantly, these more fundamental constants can be determined directly with very few animals, rather than by creating detailed time-course curves for the chemical in the living animal. Once these parameters are measured, pharmacokinetic behavior, and, to a large measure, tissue dose of parent chemical and major metabolites, can be predicted by simulation modeling. Limited experimentation then can be done *in vivo* to test the accuracy of the predicted behavior, but this limited work requires far fewer animals than conventional approaches to assessing pharmacokinetic behavior.

In the Toxic Hazards Division at Wright-Patterson AFB, Gargas and his colleagues [15] have developed straightforward *in vitro* techniques to measure tissue partition coefficients by vial equilibration studies with tissues from only a few animals and have applied this method to over 55 volatile chemicals. The data for all the chloromethanes and chloroethylenes, for instance, are shown in Table 1. In fact, with these techniques, tissues from a single animal can be used to assess the partitioning of multiple chemicals at the same time [16]. Gargas and collaborators have also pioneered noninvasive simulation approaches to determine the kinetic characteristics of chemical metabolism *in vivo* using small numbers of animals in inhalation studies (Figure 1) that do not require killing the animals to obtain the necessary data [17,18]. With these methods kinetic constants for metabolism have been estimated in rats for all the chlorinated methanes, ethanes, and ethylenes, and preliminary structure-metabolism correlations have been adduced for these chemicals [19]. Some of these results are recapitulated in Table 2. It is now possible to derive the necessary data for a PB-PK model for many vapors by experiments that can be completed in two to three weeks and require killing a very limited number of test rodents. Validation studies require more animals, but the simulation model can be used in these experiments to select dosages that ensure adequate tissue concentrations for chemical detection and to design sampling protocols that maximize information content of the kinetic curves.

With the techniques pioneered by Gargas and colleagues [15] so readily available and easily implemented, it is unconscionable today to undertake conventional pharmacokinetic time-course studies or toxicity studies with these vapors without first developing a simulation model to give the experimentalist an expectation of the outcome of the kinetic experiments and a prediction of tissue dose under differing exposure conditions. The data in Tables 1 and 2 are sufficient to create predictive kinetic models for these 10 chemicals in the male Fischer 344 rat.

TABLE 1. PARTITION COEFFICIENTS OF HALOGENATED HYDROCARBONS

Chemical	Saline	Olive Oil	Blood	Liver	Muscle	Fat
<b>Chloromethanes</b>						
Methyl chloride	0.88	8.57	2.47	3.47	0.97	13.5
Methylene chloride	5.96	131	19.4	14.2	7.92	120
Chloroform	3.38	402	20.8	21.1	13.9	203
Carbon tetrachloride	0.35	374	4.52	14.2	4.54	359
<b>Chloroethylenes</b>						
Vinyl chloride	0.43	24.4	1.68	1.60	2.20	20.0
<i>cis</i> -Dichloroethylene	3.25	278	21.6	15.3	6.09	227
<i>trans</i> -Dichloroethylene	1.41	178	9.58	8.96	3.52	148
Vinylidene chloride	0.35	64.3	5.00	4.42	2.05	68.6
Trichloroethylene	0.83	553	21.9	27.2	10.1	554
Perchloroethylene	0.79	2134	18.9	70.3	20.0	1638

TABLE 2. METABOLIC CONSTANTS OF HALOGENATED HYDROCARBONS

Chemical	$V_{max}$ ( $\mu\text{mol/h/kg}$ )	$K_m$ ( $\mu\text{M}$ )	$k_f$ ( $\text{h}^{-1}\text{kg}^{-1}$ )
<b>Chloromethanes</b>			
Methyl chloride	96.9	19.8	-
Methylene chloride	47.1	4.71	2.0
Chloroform	56.9	2.09	-
Carbon tetrachloride	2.6	1.63	-
<b>Chloroethylenes</b>			
Vinyl chloride	44.8	1.60	1.0
<i>cis</i> -Dichloroethylene	30.9	5.16	-
<i>trans</i> -Dichloroethylene	30.9	1.03	-
Vinylidene chloride	77.4	1.03	-
Trichloroethylene	83.7	1.90	-
Perchloroethylene	-	-	0.3

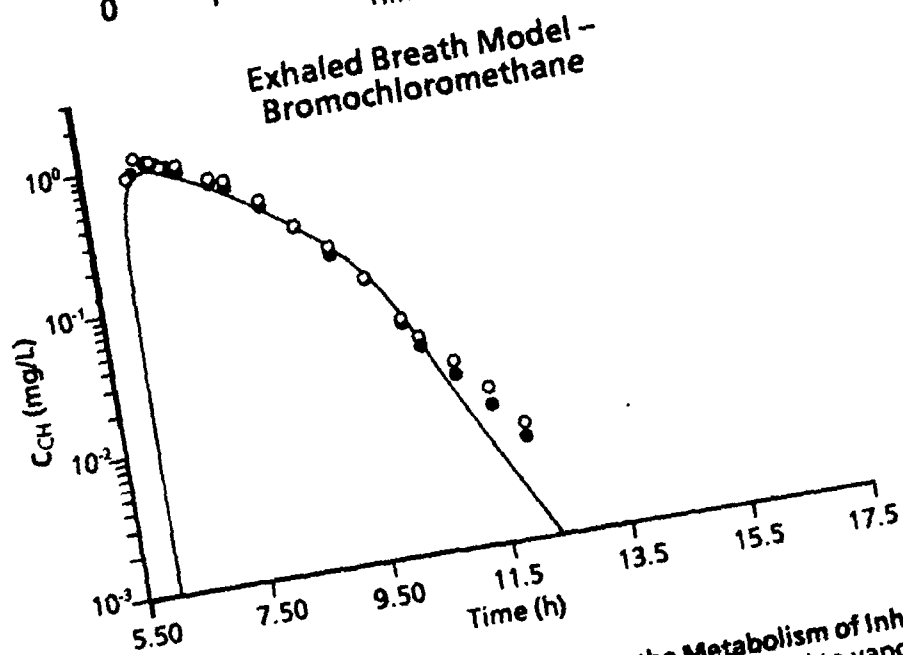
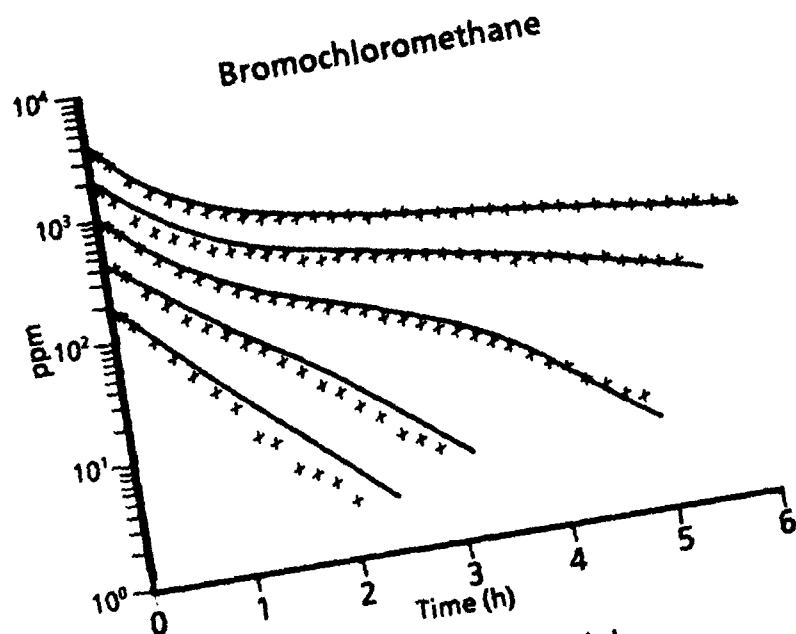


Figure 1. Simulation Techniques for Estimating Constants for the Metabolism of Inhaled Vapors in Unrestrained Rats. In gas uptake studies (Panel A) rats are exposed to vapors at several different starting concentrations. Chamber atmospheres are recirculated and the decline in concentration measured over time. The resultant curves are analyzed with a PB-PK model in which physiological and solubility parameters are fixed to literature or experimental values. A best-fit representation is obtained by varying the kinetic constants for metabolism. This example is with bromochloromethane in 9.0-L chambers occupied by three rats. In exhalation studies (Panel B) individual rats are exposed to the test vapor for a designated period of time (about 6 h). The rat is then placed in a smaller chamber through which there is a flow of fresh air. Chamber effluent concentration is measured and a time course curve generated that is fitted by varying kinetic constants within a PB-PK model. The curve also is from work with bromochloromethane using a single rat in a 2.6-L chamber. All curves in both panels were generated using identical parameters.

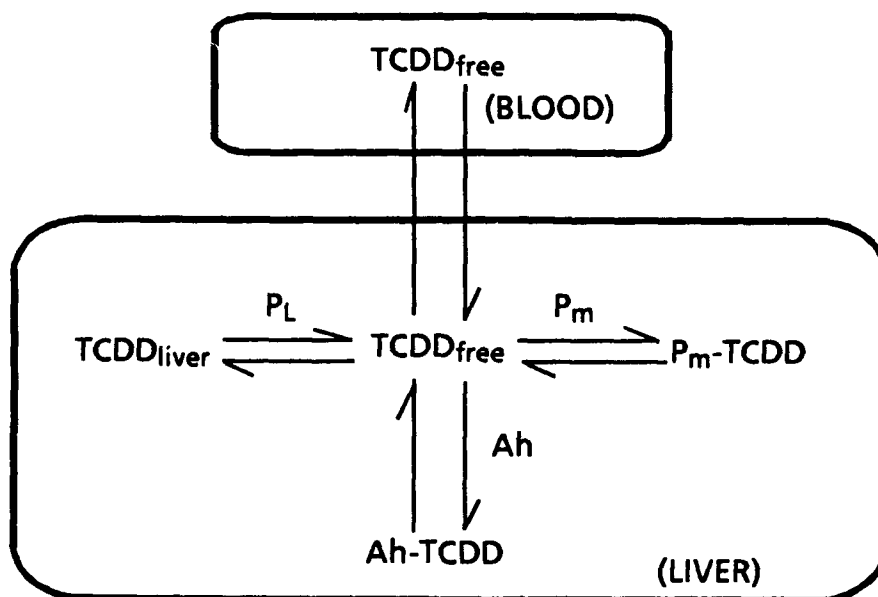
## Dioxin

2,3,7,8-Tetrachlorodibenzo-*p*-dioxin (TCDD), a highly toxic, intensively studied synthetic organic chemical, shows extreme species sensitivity in its acute toxicity and is a potent promotional carcinogen in rodent liver [20]. TCDD binds to a cytosolic protein, the Ah receptor, and the TCDD-receptor complex translocates to the nucleus where it binds to specific sites on DNA. This interaction causes increased (or perhaps decreased) transcription of particular genes including the locus for aromatic hydrocarbon hydroxylase, a microsomal cytochrome P-450 oxidase enzyme. The induction of various gene products is believed to be associated intimately with the promotional potency of TCDD as a hepatic carcinogen. The risk assessment for dioxin is based on the yield of liver tumors in female rats [21].

The voluminous toxicity testing results with TCDD have not been accompanied by studies to examine the discrete biochemical and partitioning mechanisms that give rise to TCDD distribution and elimination patterns in test species. In most species the liver TCDD concentrations are very much greater than the fat concentrations, even though dioxin is regarded as highly lipophilic. Because chronic toxicity is in some way believed to be associated with receptor occupancy in the liver, these observations of high liver concentrations seem intuitively to be of some significance. But without an understanding of the biochemical factors involved in controlling liver TCDD concentrations, we are not in a position to determine the relationship between total liver concentration and occupancy. As it turned out, the data necessary to develop the PB-PK model for TCDD disposition were already in the literature, awaiting interpretation with a quantitative model that was recently developed by Leung and colleagues [22].

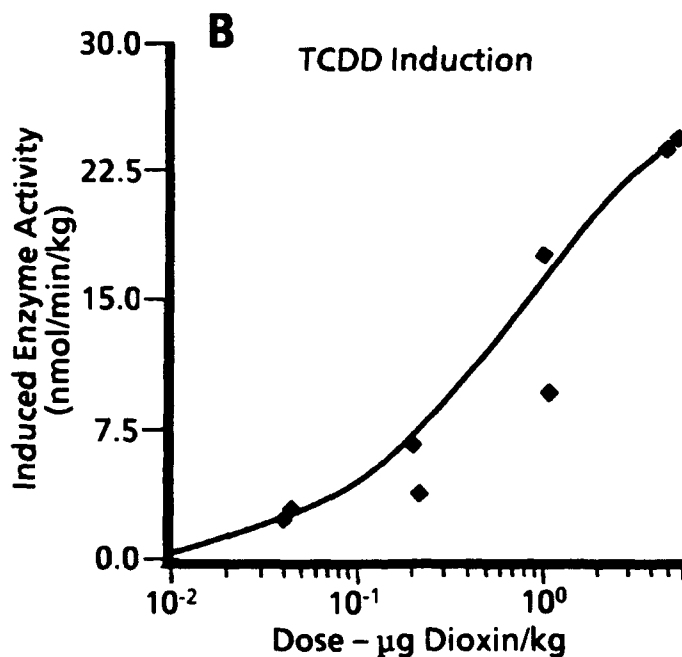
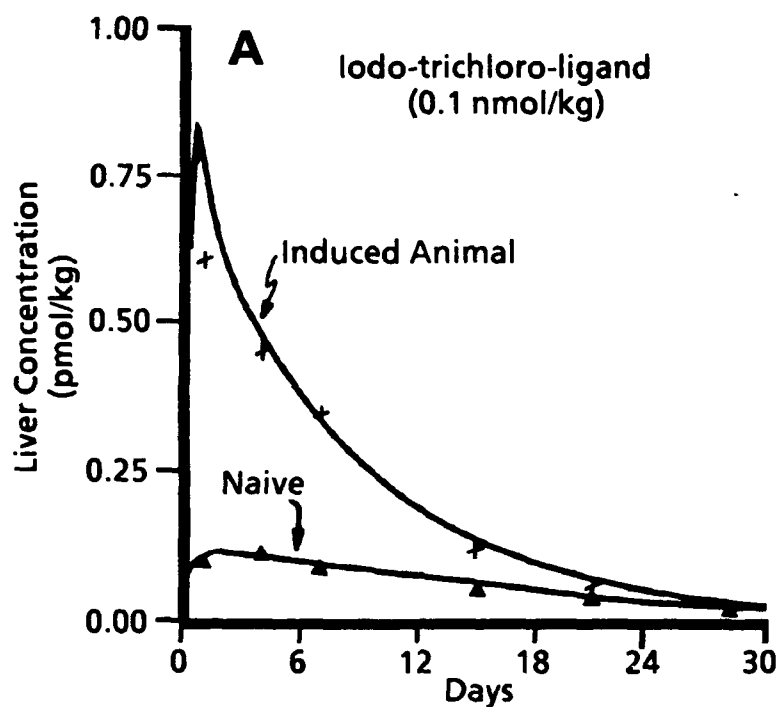
In this model, liver TCDD was present as a free amount, an amount sequestered due to simple partitioning, an amount bound to the Ah receptor, and an amount bound to specific, microsomal binding proteins ( $P_m$ ), that themselves were inducible by TCDD exposure at sufficiently high concentrations (Figure 2). The intrinsic liver-to-blood partition coefficient ( $P_L$ ) was estimated from the concentration of dioxin in other visceral organs (e.g., the kidney). Thus,  $P_L$  was about 20 and the fat-to-blood partition coefficient ( $P_F$ ) was 350. Thus, intrinsically, fat should contain some 17 times higher TCDD concentration than liver. The cytosolic receptor binding maximum and the binding affinity for the Ah receptor had been estimated by direct *in vitro* measurements [23] and could be included directly in the simulation model. When these parameters were used, simulation of TCDD distribution experiments made it readily apparent that the major contributor to the liver burden of TCDD in mice had to be binding to the secondary, microsomal binding sites. Based on the simulation analysis, these were high affinity binding sites,  $K_D$  (dissociation constant) = 20 nM, but not nearly as high affinity as the Ah receptor,  $K_D$  = 15 pM. In contrast, the microsomal sites were estimated to be present at 5000-fold higher concentrations in the liver than were the cytosolic sites. The presence of

these microsomal binding sites in mice had been reported in a thesis [24] and in the open literature [25] for rats, but their role in determining TCDD tissue disposition only became obvious through use of the quantitative simulation model for TCDD. Poland et al. [26-28] have recently examined these microsomal binding sites in mice, describing dissociation constants, capacities, and the specificity for various ligands.



**Figure 2. Schematic of the Disposition of TCDD in the Liver.** Free TCDD equilibrates between the blood and liver. In the liver three processes determine TCDD sequestration. Nonspecific partitioning is related to the solubility of TCDD in liver with  $P_L$  representing linear binding to liver constituents. Specific, capacity limited binding sites exist both with the cytosolic Ah receptor and with the microsomal binding proteins ( $P_m$ ).

The biological complexity of liver sequestration of TCDD was even more dramatically evident in studies with 125-I-iodotrchlorodibenzo-*p*-dioxin [26-28]. This ligand, which has enzyme-inducing and cytosolic-receptor binding properties similar to that of TCDD itself, was prepared at an extremely high specific activity by Poland and colleagues [26]. A kinetic study was conducted at noninducing concentrations of this ligand (0.1 nmol/kg) in both naive mice and mice pretreated with 0.1  $\mu$ mol TCDD/kg. These kinetic results were analyzed with a PB-PK simulation model by Leung et al. [29]. The differences in liver and fat concentrations between these two treatment groups indicated that TCDD induction increased the microsomal binding protein by about eightfold (Figure 3). In naive mice the liver-to-fat ratio was only 0.1 (similar to that observed for TCDD in humans exposed at low, environmentally realistic concentrations), while it was between 2.0 and 6.1 in the TCDD-pretreated mice.



**Figure 3. PB-PK Simulation Modeling with TCDD.** Mice were treated with either 0 or 0.10  $\mu\text{mol}$  TCDD/kg and then dosed with 0.1 nmol iodo trichlorodibenzodioxin/kg [29]. TCDD induction increased the hepatic concentration of TCDD (Panel A) by causing an eightfold induction in microsomal binding proteins from 1.75 to 10.0 nmol/liver. Rats were treated with various dosages of TCDD and the extent of induction of microsomal oxidase activities measured after three days (Panel B). These data were fit by the TCDD simulation model providing an estimate of the Ah receptor dissociation constant (15 pM) in the rat.

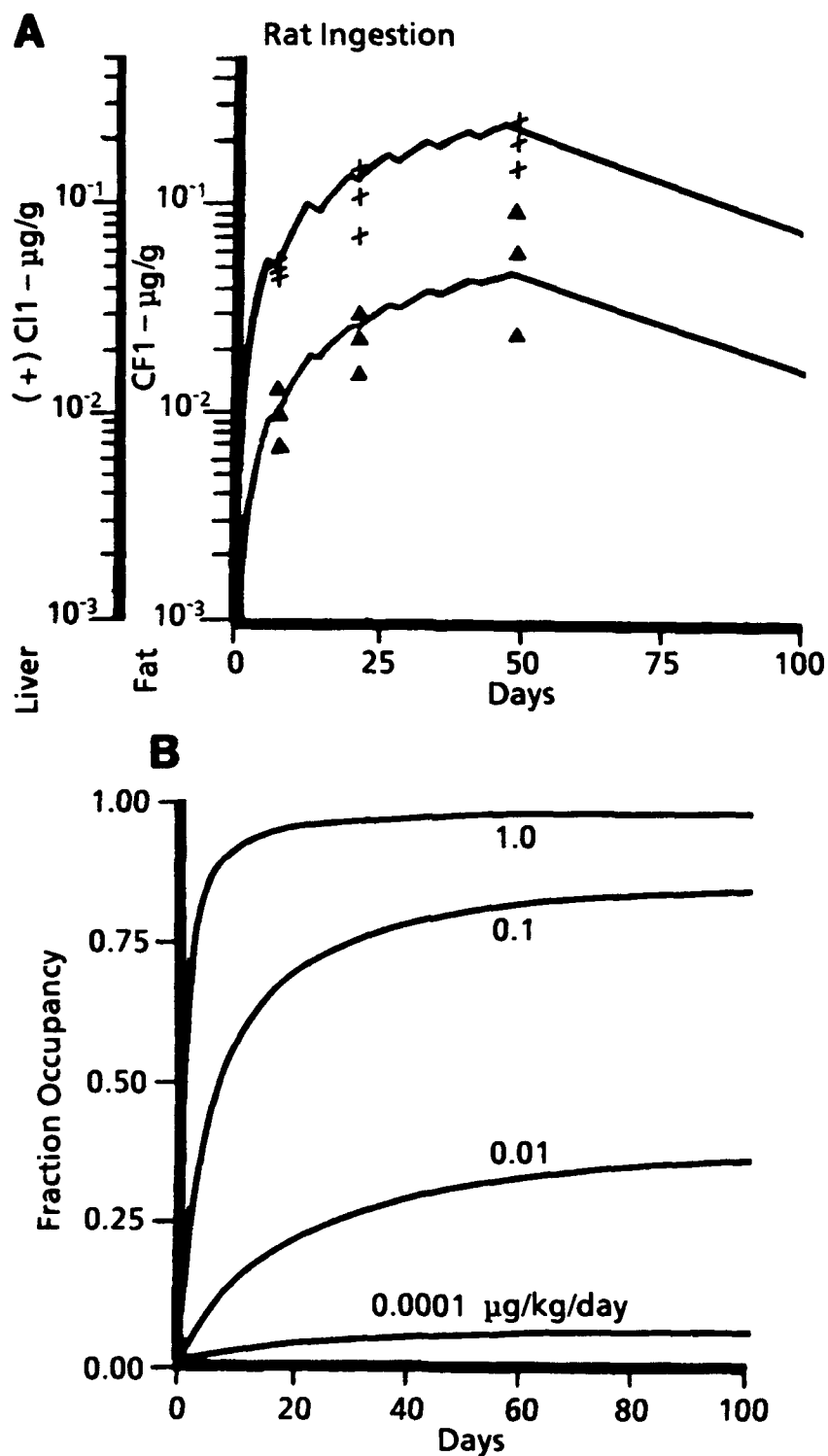
The dioxin simulation model was scaled from mice to rats to examine expected tissue burdens of TCDD on subchronic dosing and to estimate the binding affinity of the Ah receptor *in vivo* from induction studies. By fitting enzyme induction data from McConnell et al. [30] with the simulation model (Figure 3), the Ah receptor dissociation constant was estimated to be 15 pM. The simulation model was used to analyze data from Rose et al. [31] in which rats were dosed daily with dioxin at three dose levels for seven weeks. The simulation of this experiment included induction of the microsomal binding sites. To obtain a coherent description of liver and fat concentrations at all three dose levels (Figure 4), the microsomal binding maximum increased from 25 nmol/liver in a naive rat to 200 nmol/liver in a fully induced rat. Because of induction, the observed liver:fat concentration ratio is expected to be markedly concentration dependent, increasing as dose increases in the range of the Rose et al. experiments. Nearly complete occupancy of the Ah receptor is predicted at steady-state for the three dosage levels used; that is, down to 0.01  $\mu\text{g}/\text{kg}/\text{day}$ . The TCDD simulation model for the rat can be used to calculate Ah occupancy over the course of the bioassay (Figure 4), showing that the incidence of tumors does indeed show a correlation with expected occupancy.

The TCDD simulation model was developed almost entirely from literature experiments that were not designed specifically to support a quantitative model for TCDD disposition. Only the iodinated-ligand work in mice was done (at least partially) in response to experiments suggested by the model. In this case, the expectation generated by the model was that the liver:fat ratio of TCDD should be markedly concentration dependent at very low doses. The iodinated ligand experiment amply verified this expectation (Figure 3). The simulation approach now sharply outlines the course of experimentation for laboratory primate or human tissues. Estimates of the biochemical constants for both binding sites, and for the inducibility of the microsomal binding sites, need to be obtained in primates. Limited studies also might be considered to obtain these constants using human tissues obtained from accident victims or from surgical procedures. With such data, an Ah-occupancy simulation model for humans could be developed and used in risk assessment calculations. Any combined PB-PK and pharmacodynamic model for TCDD carcinogenesis must include a step accounting for the promotional efficacy of the Ah-TCDD complex. More refined human TCDD risk assessments will be highly dependent on assumptions about the relevance to humans of these promotional advantages in rodents. More complete simulation models for the intriguing biological effects of TCDD await a better understanding of the detailed mechanisms of its cellular activity.

### **CTFE Oligomers**

Ongoing studies at the Toxic Hazards Division with CTFE oligomers provide an example of aggressive development of a simulation model early in the course of toxicity testing. CTFE oligomeric fluids are potential candidate materials for use as inert, nonflammable oils, lubricants, and waxes. In a 90-day inhalation study with a mixture containing trimeric and tetrameric components, marked liver





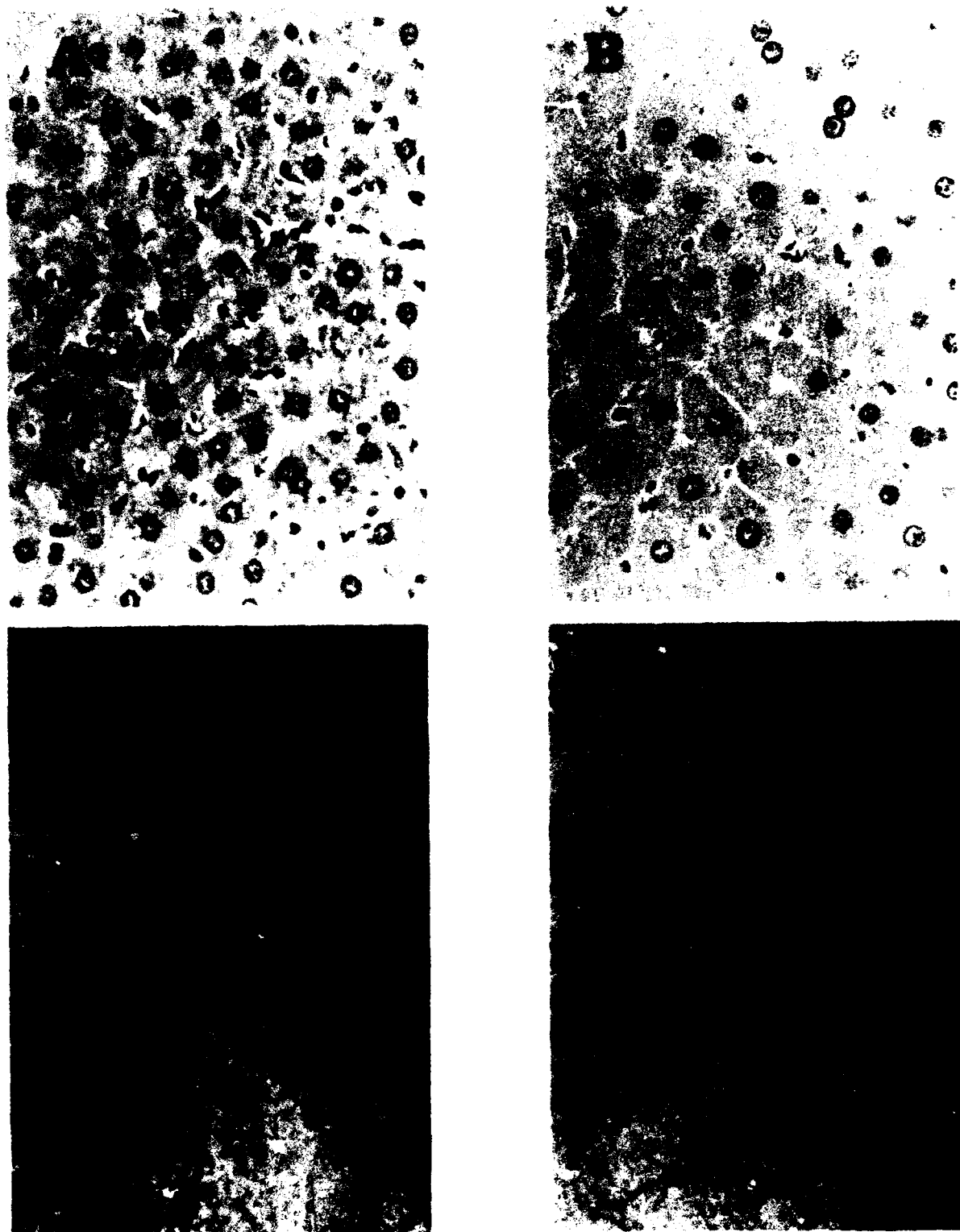
**Figure 4.** Simulation of Liver TCDD Concentrations during Chronic Administration. The TCDD simulation model with induction of microsomal binding proteins was used to describe literature data at three daily doses of TCDD for five days/week for seven weeks (Panel A). The model then was used to estimate Ah occupancy for the doses used in the cancer bioassay study (Panel B).

damage was noted at inhaled concentrations of 0.25, 0.50, and 1.00 mg oligomer/L air [32]. The livers of rats exposed to high concentrations were increased in size by as much as 300%. Individual liver cells were grossly enlarged, and there were multiple changes in the subcellular architecture of the cells, including increased numbers of peroxisomes (Figure 5). These changes were not fully resolved nearly five months following the end of exposure. These changes were noted at all three exposure concentrations. The response of the liver was very similar to that seen with perfluoro-*n*-decanoic acid (PFDA), another material studied extensively by Air Force investigators at Wright-Patterson AFB [33,34]. Increased steady-state urinary fluoride concentrations in the CTFE oligomer study were consistent with metabolism of several  $\mu\text{g}$  of the CTFE oligomers per day (Figure 6). The most likely explanation of these observations is that the liver effects were caused by the presence of persistent, perhalogenated fatty acids produced by  $\omega$ -oxidation of the CTFE oligomers.

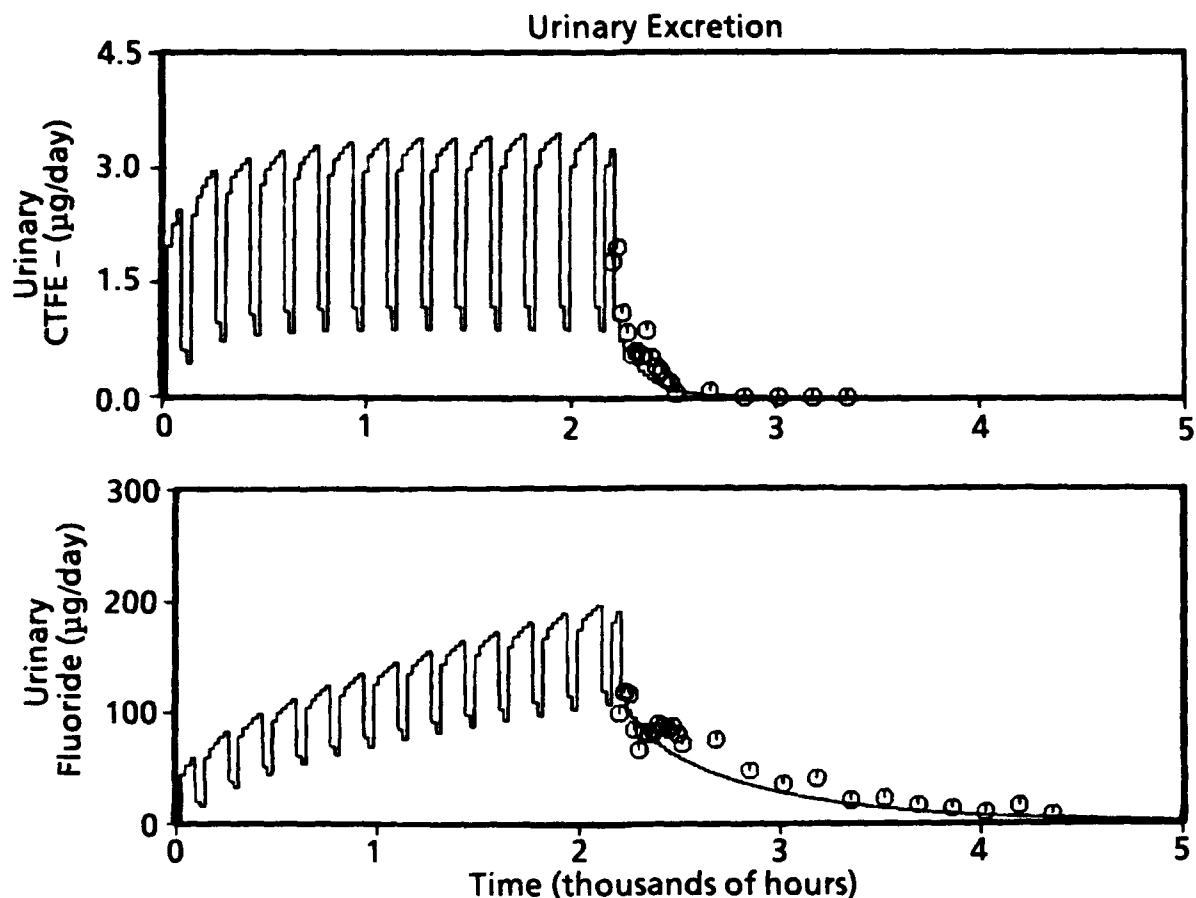
Experiments now underway are designed to determine a no-effect exposure concentration and to ensure collection of quantitative data in both rats and primates to support a simulation model. The simulation model uses a simplified PB-PK description to predict distribution of oligomer to tissues, with metabolism to perhaloacids in the liver (Figure 7). Perhaloacids are eliminated slowly by urinary and fecal excretion. PFDA, for instance, is eliminated from male rats with an elimination constant of 0.01/day; that is, they have a 70-day half-life [35]. The 90-day no-effect inhalation study will include rats used specifically for measuring the liver concentration of perhaloacids during the exposure and at various times post-exposure to estimate elimination rate constants for these acids. The goal is to describe no-effect concentrations based both on CTFE airborne concentrations and, more importantly for extrapolation, on the liver concentration of the perhaloacid.

The issue remaining after completing the rat inhalation studies and the acid toxicity studies is extrapolation of the results to humans. The questions are both qualitative (will these acids have similar toxic effects in humans?) and quantitative (is the dose-response relationship for the acids similar in rodents and humans?). There is considerable debate over whether the rodent hepatic toxicity of peroxisomal proliferating agents is really a relevant endpoint to use in a human risk assessment. In this regard, chronic feeding studies in monkeys with perfluoro-*n*-octanoic acid (PFOA) revealed no hepatic effects of this material [36]. In the rat, the primary target tissue of PFOA in these chronic feeding studies was the liver.

To address these issues, the toxicity of the acid will be examined in a small number of primates. These studies will assess the tissue sensitivity to the CTFE acid and determine the elimination rate of the acid from the primate by a sequence of biopsies in these animals. Second, rates of oligomer oxidation will be measured *in vitro* in rat, test primate, and, if at all possible, human liver samples. These rates of oxidation to the acids can be used in simulation modeling to predict situations in which CTFE acids are likely to accumulate to toxic concentrations in exposed humans.



**Figure 5. Pathological Observations on Liver from Rats Exposed to CTFE Oligomer Vapor.** Representative light and transmission electron microscopic pictures of the changes caused by CTFE exposure for 90 days at 0.5 mg/L air. At the light microscopy level, cells were markedly enlarged compared to controls (Panel A and B). When observed by electron microscopy, there was an increase in peroxisomes and smooth endoplasmic reticulum and alterations in morphology of the mitochondria as compared to the same control rats (Panel C and D).



**Figure 6.** Elimination of CTFE Oligomers and Fluoride in the Urine of CTFE-Exposed Rats. The data for CTFE elimination representing concentrations of what are believed to be primarily trimeric species of the oligomer were obtained by gas chromatographic analysis (Panel A). The urinary fluoride concentrations were determined with a fluoride electrode (Panel B). Smooth curves were generated from the CTFE simulation model.

The CTFE oligomer simulation model highlights the importance of rates of oxidation of the oligomer to the acid and rates of elimination as crucial parameters for extrapolating toxicity of similar chemicals. In this way the model itself can be used to screen chemicals for anticipated toxicity. For instance, toxicity should be reduced if the rates of oxidation *in vivo* were reduced. In the present manufacturing process, the CTFE oligomers are initiated and terminated with chlorine. Carbon-fluorine bonds are more stable than carbon-chlorine bonds. Oligomers initiated and terminated with fluorine instead of with chlorine may pose a significantly reduced risk of toxicity. To test this, we simply measure the rate of *in vitro* oxidation of a fluorinated oligomer, compare it to that of the CTFE oligomers previously examined, and simulate expected human accumulation of toxic acids with the model. In this way a variety of potential candidate materials can be screened without recourse to

extensive animal testing. We are now screening a series of perfluoroalkylether fluids which also have potential uses as oils. By use of these *in vitro* metabolic studies and computer simulation, the toxicologist can interact with engineering personnel early in the systems development process to weed out candidate materials that are expected to have a high order of toxicity. In addition to improving the utility of the toxicity tests, this interchange between the system engineer and toxicologist can minimize investment in costly engineering tests which are overcome by adverse findings in toxicity tests conducted late in the product development cycle.

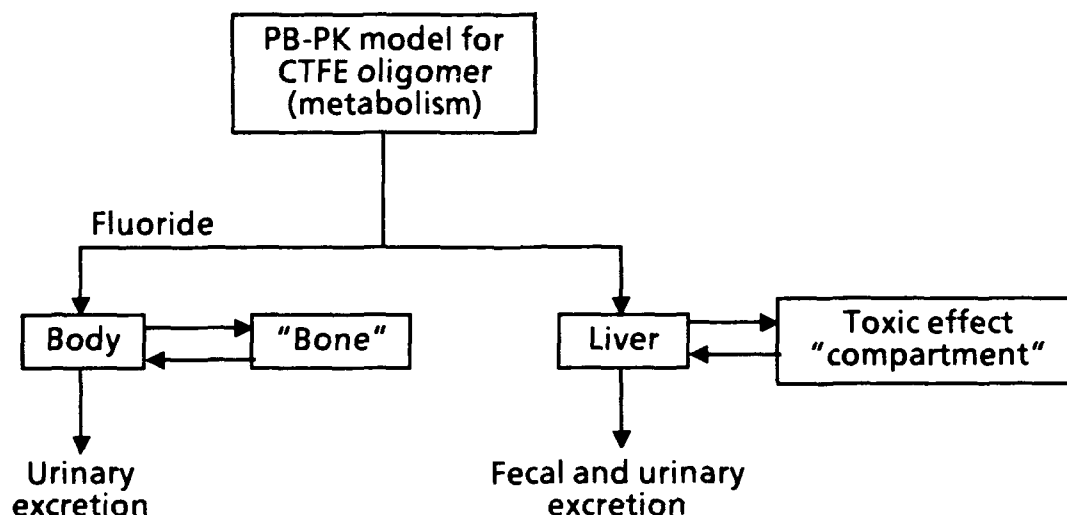


Figure 7. Schematic of the Simulation Model for CTFE Oligomers and Metabolites. Metabolism of the oligomer in the liver produces inorganic fluoride and perhalogenated fatty acid analogs. Half the fluoride is rapidly eliminated and the other half is stored in the bone matrix. The simulation model indicated that about 200 mg of the oligomer would have to be converted to the acid during the 90-day exposure period to account for the amounts of excreted fluoride observed during and after the 90-day exposure. The acids are presumed to be the toxic form of these perhalogenated chemicals.

## DISCUSSION

The design philosophy in using simulation to improve toxicity testing is to quickly generate PB-PK models for the behavior of parent chemical and major metabolites in the test animal. The data to generate these models can frequently be obtained from simple *in vitro* experimentation or limited *in vivo* studies. Pharmacokinetic data acquisition then can either precede or proceed in parallel with toxicity studies. In either case, the strategy is to develop a target tissue dose simulation model that can quickly be applied to subsequent experiments and conveniently applied to predict behavior under other experimental conditions and in other species, especially humans. This very ambitious approach to the conduct of toxicity studies is not at all out of the realm of possibility for the great majority of chemicals under test. In fact, often much of the information needed to create PB-PK models is already available, although somewhat dispersed, in the toxicology literature. In recent years

PB-PK models have been developed for a variety of chemicals, including polychlorinated biphenyls [37], dioxin [22], cancer chemotherapeutic agents of various kinds [38], halogenated hydrocarbon solvents [39], and several commercially important drugs [40]. These studies create a data base guiding the rapid deployment of modeling for subsequent chemicals. A good description of the role of pharmacokinetics in developing toxicity testing protocols has also been provided [41].

As toxicologists gain experience in the use of these simulation models for estimating tissue dose, their development and validation will correspondingly require less work. The ideal will be development of simulation models based on structure-activity relationships for solubility, binding properties, metabolism, and such, and limited *in vitro* studies with isolated cell lines or subcellular organelles. We are very close to this ideal with the low-molecular weight, chlorinated hydrocarbon vapors, and with the extensive data base on the *in vitro* characteristics of TCDD-analog receptor binding, not too far off from this ideal for some of these higher molecular weight chlorinated hydrocarbon contaminants.

Intellectually, the ability to predict a particular outcome is itself a powerful tool for improving the information content of an experiment. With conventional PK modeling, time-course data are central and is fitted to obtain a description of the data without regard to the mechanistic underpinnings of the behavior. Simulation models in effect say that the behavior is predictable from a few basic parameters. When a simulation agrees with data, there is cause for increased confidence in the accuracy of the physiological description of the animal-chemical system. When the model fails, it points to a lack of understanding of the basic biological processes. The failure of a basic physiological model for inhaled vapors for styrene [42], *cis*- and *trans*-dichloroethylene [43], and allyl chloride [44] was the first evidence of complexities in the behavior of these particular chemicals. Further study showed that the basis of the failure of the predictions were enzyme induction, enzyme inactivation, and cofactor (glutathione) depletion, respectively. Without a PB-PK model, these data would have been blindly fit and the information content ignored. Structural models, when they fail, can be as informative, and frequently more interesting, than in the cases where they are clearly successful in their predictions [1,2,3,43,45].

Another aspect of simulation modeling that leads to reduction in use of higher animals is the focus on providing a quantitative understanding of the toxicity in one particular target species, the rodent, and conducting extrapolation of crucial elements of the overall toxicologic mechanism to primate or human target species. This is a very different emphasis from the prevailing approach, which is to examine the toxicity qualitatively in several animal species and to extrapolate based on the most sensitive species. In the simulation approach, the toxicity observed in the rodent is verified as relevant for the primate by observations in restricted numbers of animals or preferably in isolated tissues. To our minds, there is little to no justification for examining other species, such as the dog, for

instance, unless there is a compelling biological reason for believing that some other species is particularly appropriate for the endpoint under study.

The most direct extrapolation occurs in models where critical parameters associated with toxicity are identified in the rodent simulation model and where these same parameters can be estimated directly with human tissues. Andersen et al. [46] conducted a simulation-based human risk assessment of the carcinogenicity of methylene chloride. Mice exposed to either 2000 or 4000 ppm methylene chloride for 6 h/day, 5 day/week, for two years, developed tumors of the liver and lung in a concentration-dependent manner. The tumorigenicity appeared to be related to the rate of metabolism of methylene chloride by a glutathione transferase (GST)-mediated conjugation with glutathione. Analysis with the simulation model determined that the most critical parameters for tissue dose of this GST metabolite were the estimated volume of the target tissue and the rate of GST metabolism in the target tissue. As a result of this analysis, Reitz and co-workers [47] subsequently measured the rates of GST conjugation with methylene chloride *in vitro* with lung and liver tissue from four species: mouse, rat, hamster, and human accident victims. The constants derived from this work then were used to refine the human risk assessment within the framework of a PB-PK model that calculated liver and lung tissue dose of the GST metabolite [48].

For tissue dose extrapolation, these models readily support high-to-low dose, dose route, dose rate, and interspecies extrapolations [1,7,46]. In addition, these models point the way toward interchemical extrapolation. A successful simulation model faithfully introduces the important biological parameters that regulate tissue concentrations and important tissue interactions. After a model is successfully developed for one member in a class of related chemicals, the basic model structure can be used to direct experiments for other chemicals in the class. With the volatile chemicals, the partition coefficients and biochemical constants for metabolism control the disposition of parent chemical and major metabolites. With the polyhalogenated dioxins and furans and their analog chemicals, tissue disposition is largely determined by the presence of specific binding sites in various tissues and the rate of elimination. In rats and mice, elimination is controlled by rates of metabolism. In humans and guinea pigs, unchanged parent chemical is eliminated in feces by passive diffusion across intestinal tissue into the contents of the gastrointestinal tract. These processes are in turn related to binding capacities and affinities of the proteins, rates of metabolism, and relative solubilities in blood, intestinal tissues, and intestinal contents. Perhaloalkanes, CTFE oligomers, and similar chemicals, including highly chlorinated paraffins [49], demonstrate a consistent toxicologic picture that appears to be related to conversion of these chemicals to persistent haloacids. With these chemicals, the predominant factors involved in toxicity are rates of conversion of the parent alkane to acid metabolites, the life-time of the acid in the body, and the relative biological efficacy of the acid itself. Only the biological half-lives need to be determined in animals, and this can be done in

nonterminal experiments by following urinary and fecal concentrations over time or by biopsies on liver tissue.

In these simulations the improvements in protocol design and interpretive ability arise by developing easily implemented models to predict relevant measures of tissue dose under a variety of experimental conditions in various animal species. Tissue dose is an elusive concept. It ranges from simple measures, such as chemical concentration, metabolite concentration, or integrated exposure to these materials, to more biologically relevant measures, such as DNA adducts, macromolecular protein binding, cellular mitotic rates, or increased gene expression, which result from the exposure to an active chemical [4,6]. While the simulation models discussed in this paper deal with the tissue exposure to parent chemical and metabolite or with receptor occupancy, it is relatively easy to extend them to include the more biological endpoints and focus more on tissue response (pharmacodynamics) than on the chemical itself. In the future more and more simulation models will include the biological response as well as the physical chemical aspects of chemical disposition. These descriptions will formulate the pharmacodynamic consequences of chemical exposure in quantitative, mathematical form. Examples of pharmacodynamic modeling have been provided for prednisolone [50] and for chemical carcinogenesis [4].

A simulation model is really little more than a set of mass-balance differential equations that are solved by numerical methods. These systems of equations can be readily solved by software packages available from a variety of vendors. The models discussed here were all written for IBMPC-compatible systems and used ACSL - Advanced Continuous Simulation Language, supplied by Mitchell and Gauthier Inc., Concord, MA. The models for the volatiles and dioxin require about 1 minute processor time on an IBMPC-compatible computer with an 80286 microprocessor and a 80287 math co-processor. The software is also available for mainframe operation. The 90-day CTFE simulation models were run on a Digital Equipment Corporation, VAX 8550 minicomputer. A demonstration program for examining the distribution of volatiles can be obtained by contacting the authors or Mitchell and Gauthier, Inc.

#### **ACKNOWLEDGMENTS**

We thank Dr. Allen Vinegar, NSI Technology Services Corp., for allowing us use of his preliminary modeling results with CTFE oligomers and with the fluoride ion that is released by CTFE oligomer metabolism.



## REFERENCES

- 1 Clewell, H.J.,III and Andersen, M.E. (1985) Risk assessment extrapolations and physiological modeling. *Toxicol. Ind. Health* 1, 111-131.
- 2 Clewell, H.J.,III, Andersen, M.E., MacNaughton, M.G. and Stuart, B.O. (1988) Toxicokinetics: An analytical tool for assessing chemical hazards to man. *Aviat. Space Environ. Med.* 59, (suppl.) A1-A7.
- 3 Clewell, H.J.,III and Andersen, M.E. (In Press) Biologically-motivated models for risk assessment. *Health Phys.*
- 4 Conolly, R.B., Reitz, R.H., Clewell, H.J.,III and Andersen, M.E. (1988) Pharmacokinetics. Biochemical mechanism, and mutation accumulation: A comprehensive model for chemical carcinogenesis. *Toxicol. Lett.* 43, 189-200.
- 5 Bischoff, K.B. and Brown, R.G. (1966) Drug distribution in mammals. *Chem. Eng. Prog. Symp. Series.* 62, 33-45.
- 6 Andersen, M.E. (1987) Tissue dosimetry in risk assessment: What's the problem here any way? *Drinking Water Health* 8, 8-23.
- 7 Ramsey, J.C. and Andersen, M.E. (1984) A physiological model for the inhalation pharmacokinetics of styrene in rats and humans. *Toxicol. Appl. Pharmacol.* 73, 159-175.
- 8 Gargas, M.L., Clewell, H.J.,III and Andersen, M.E. (1986) Metabolism of inhaled dihalomethanes: Differentiation of kinetic constants for two independent pathways. *Toxicol. Appl. Pharmacol.* 82, 211-223.
- 9 Paustenbach, D.J., Clewell, H.J.,III, Gargas, M.L. and Andersen, M.E. (1988) A physiologically-based pharmacokinetic model for carbon tetrachloride. *Toxicol. Appl. Pharmacol.* 96, 191-211.
- 10 D'Souza, R.W., Francis, W.R. and Andersen, M.E. (1987) A physiologic model for tissue glutathione depletion and increased resynthesis following ethylene dichloride, exposure. *J. Pharmacol. Exp Ther.* 254, 563-568.
- 11 Ward, R.C., Travis, C.C., Hetrick, D.M., Andersen, M.E. and Gargas, M.L. (1988) Pharmacokinetics of tetrachloroethylene. *Toxicol. Appl. Pharmacol.* 93, 108-117.
- 12 D'Souza, R.W. and Andersen, M.E. (1988) Physiologically-based pharmacokinetic model for vinylidene chloride. Integration of diverse experimental findings into a unified kinetic description. *Toxicol. Appl. Pharmacol.* 95, 230-240.
- 13 Young, J.D., Ramsey, J.C., Blau, G.E., Karbowski, R.J., Nitschke, K.D., Slauter, R.W. and Braun, W.H. (1979) Pharmacokinetics of inhaled or intraperitoneally administered styrene in rats. In: *Toxicology and Occupational Medicine, proceedings of the Tenth Inter-America Conference on Toxicology and Industrial Medicine, Elsevier/North Holland, New York*, pp. 297-310.
- 14 Ramsey, J.C., Young, J.D., Karbowski, R., Chenoweth, M.B., McCarty, L.P. and Braun, W.H. (1980) Pharmacokinetics of inhaled styrene in human volunteers. *Toxicol. Appl. Pharmacol.* 53, 54-63.

- 15 Gargas, M.L., Burgess, R.J., Voisard, D.E., Cason, G.H. and Andersen, M.E. (In Press) Partition coefficients of low molecular weight volatile chemicals in various liquids and tissues. *Toxicol. Appl. Toxicol.*
- 16 Fiserova-Bergerova, V. and Diaz, M.L. (1986) Determination and prediction of tissue-gas partition coefficients. *Int. Arch. Occup. Environ Health*, 58, 75-87.
- 17 Gargas, M.L., Clewell, H.J., III and Andersen, M.E. (1986) A simulation approach for analyzing gas uptake data. *Toxicol. Appl. Pharmacol.* 86, 341-352.
- 18 Gargas, M.L. and Andersen, M.E. (Submitted) Determining kinetic constants for chlorinated ethylene metabolism in the rat from rates of exhalation. *Toxicol. Appl. Pharmacol.*
- 19 Gargas, M.L., Seybold, P.G. and Andersen, M.E. (1988) Modeling the tissue solubilities and metabolic rate constant ( $V_{max}$ ) of halogenated methanes, ethanes and ethylenes. *Toxicol. Lett.* 43, 235-256.
- 20 Safe, S.H. (1986) Comparative toxicology and mechanism of action of polychlorinated dibenzo-*p*-dioxins and dibenzofurans. *Ann. Rev. Pharmacol. Toxicol.* 26, 371-399.
- 21 Portier, C.J., Hoel, D.G. and Van Ryzin, J. (1984) Statistical analysis of the carcinogenic bioassay data relating to the risks from exposure to 2,3,7,8-tetrachlorodibenzo-*p*-dioxin. In: William J. Lowrance (Ed), *Public Health Risks of the Dioxins*, William Kaufmann, Los Altos, CA, pp. 99-119.
- 22 Leung, H.W., Ku, R.H., Paustenbach, D.J. and Andersen, M.E. (1988) A physiologically-based pharmacokinetic model for 2,3,7,8-tetrachlorodibenzo-*p*-dioxin in C57BL/6J and DBA/2J mice. *Toxicol. Lett.* 42, 15-28.
- 23 Gasiewicz, T.A. and Rucci, G. (1984) Cytosolic receptor for 2,3,7,8-tetrachlorodibenzo-*p*-dioxin. Evidence for a homologous nature among various mammalian species. *Mol. Pharmacol.* 26, 90-98.
- 24 Teitelbaum, P.J. (1978) The Hepatic Uptake of 2,3,7,8-Tetrachlorodibenzo-*p*-dioxin in the Mouse. Ph.D. Dissertation, University of Rochester, Rochester, N.Y.
- 25 Voorman, R. and Aust, S.D. (1987) Specific binding of polyhalogenated aromatic hydrocarbon inducers of cytochrome P-450d to the cytochrome and inhibition of its estradiol 2-hydroxylase activity. *Toxicol. Appl. Pharmacol.* 90, 69-78.
- 26 Poland, A., Teitelbaum, P., Glover, E. and Kende, A. (Submitted) Stimulation of *in vivo* hepatic uptake binding of [<sup>125</sup>I]-2-iodo-3,7,8-trichlorodibenzo-*p*-dioxin by the administration of agonists for the Ah receptor. *Mol. Pharmacol.*
- 27 Poland, A., Teitelbaum, P. and Glover, E. (Submitted) The [<sup>125</sup>I]-2-iodo-3,7,8-trichlorodibenzo-*p*-dioxin binding species in mouse liver induced by agonists for the Ah receptor: Characterization and identification. *Mol. Pharmacol.*
- 28 Poland, A., Geiger, P. and Glover, E. (Submitted) Factors affecting the elimination rate of [<sup>125</sup>I]-3,7,8-trichlorodibenzo-*p*-dioxin in mice as determined by whole body counting. *Mol. Pharmacol.*

- 29 Leung, H.W., Paustenbach, D.J., Murray, F.J. and Andersen, M.E. (Submitted) A physiologically-based pharmacokinetic description of the tissue distribution and enzyme inducing properties of 2,3,7,8-tetrachlorodibenzo-*p*-dioxin in the rat. *Toxicol. Appl. Toxicol.*
- 30 McConnell, E.E., Lucier, G.W., Rumbaugh, R.C., Albro, P.W., Harvan, D.J., Hass, J.R. and Harris, M.W. (1984) Dioxin in soil: Bioavailability after ingestion by rats and guinea pigs. *Science* 223, 1077-1079.
- 31 Rose, J.Q., Ramsey, J.C., Wentzler, T.H., Hummel, R.A. and Gehring, P.J. (1976) The fate of 2,3,7,8-tetrachlorodibenzo-*p*-dioxin following single and repeated oral doses to the rat. *Toxicol. Appl. Pharmacol.* 36, 209-226.
- 32 Houston, W.E. and Kutzman, R.S. (1988) 1987 Toxic Hazards Research Unit Annual Report. Report #AAMRL-TR-88-008, Harry G. Armstrong Aerospace Medical Research Laboratory, Wright-Patterson Air Force Base, OH.
- 33 Olson, C.T. and Andersen, M.E. (1983) The acute toxicity of perfluorooctanoic and perfluorodecanoic acid in male rats and effects on tissue fatty acids. *Toxicol. Appl. Pharmacol.* 70, 362-372.
- 34 George, M.E. and Andersen, M.E. (1986) Toxic effects of nonadecafluoro-*n*-decanoic acid in rats. *Toxicol. Appl. Pharmacol.* 85, 169-180.
- 35 George, M.E., Pilcher, G.D., and Andersen, M.E. (1989) Distribution and excretion of perfluoro-*n*-decanoic acid in the rat. *The Toxicologist* 9, 229.
- 36 Griffith, F.D. and Long, J.E. (1980) Animal toxicity studies with ammonium perfluorooctanoate. *Amer. Ind. Hyg. Assoc. J.* 41, 576-583.
- 37 Matthews, H.B. and Dedrick, R.L. (1984) Pharmacokinetics of PCBs. *Ann. Rev. Pharmacol. Toxicol.* 24, 85-103.
- 38 Himmelstein, K.J. and Lutz, R.J. (1979) A review of the application of physiologically-based pharmacokinetic modeling. *J. Pharmacokin. Biopharm.* 7, 127-137.
- 39 Reitz, R.H., Nolan, R.J. and Schumann, A.M. (1988) Development of multispecies, multiroute pharmacokinetic models for methylene chloride and 1,1,1-trichloroethane (methyl chloroform). *Drinking Water Health* 8, 391-409.
- 40 Gerlowski, L.E. and Jain, R. (1983) Physiologically-based pharmacokinetic modeling: Principles and applications. *J. Pharm. Sci.* 72, 1103-1126.
- 41 Reitz, R.H., Ramsey, J.C., Andersen, M.E. and Gehring, P.J. (1988) Integration of pharmacokinetics and pathological data in dose selection for chronic bioassays. In: Grice, H.C. and Ciminera, J.L. (Eds) *Carcinogenicity: The Design and Interpretation of Long-Term Animal Studies*, Springer-Verlag, NY, pp. 55-64.
- 42 Andersen, M.E., Gargas, M.L. and Ramsey, J.C. (1984) Inhalation pharmacokinetics: Evaluating systemic extraction, total *in vivo* metabolism, and the time course of induction for inhaled styrene based on steady-state blood:gas concentration ratios. *Toxicol. Appl. Pharmacol.* 73, 176-187.

- 43 Clewell, H.J.,III and Andersen, M.E. (1987) Dose, species and route extrapolations with a physiologically based model. *Drinking Water Health* 8, 159-182.
- 44 Andersen, M.E., Clewell, H.J.,III, Gargas, M.L.and Conolly, R.B. (1986) A physiological pharmacokinetic model for hepatic glutathione (GSH) depletion by inhaled halogenated hydrocarbons. *The Toxicologist* 6, 148.
- 45 D'Souza, R.W. and Boxenbaum, H. (1988) Physiological pharmacokinetic models: Some aspects of theory, practice and potential. *Toxicol. Ind. Health* 4, 151-171.
- 46 Andersen, M.E., Clewell, H.J.,III, Gargas, M.L., Smith, F.A. and Reitz, R.H. (1987) Physiologically-based pharmacokinetics and the risk assessment process for methylene chloride. *Toxicol. Appl. Pharmacol.* 87, 185-205.
- 47 Reitz, R.H., Mendrala, A.L. and Guengrich, F.P. (1988) *In vitro* metabolism of methylene chloride in human and animal tissues: Use in physiologically based pharmacokinetic models. *Toxicol. Appl. Pharmacol.* 97, 000-000.
- 48 Reitz, R.H., Mendrela, A.L., Park, C.N., Andersen, M.E. and Guengerich, F.P. (1988) Incorporation of *in vitro* enzyme data into the physiologically based pharmacokinetic (PB-PK) model for methylene chloride: Implications for risk assessment. *Toxicol. Lett.* 43, 97-116.
- 49 Bucher, J.R., Alison, R.H., Montgomery, C.A., Huff, J., Haseman, J.K., Farnell, D., Thompson, R. and Prejean, J.D. (1987) Comparative toxicity and carcinogenicity of two chlorinated paraffins in F344/N Rats and B6C3F1 mice. *Fundam. Appl. Toxicol.* 9, 454-468.
- 50 Boudinot, F.D., D'Ambrosio, R.D. and Jusko, W.J. (1986) Receptor-mediated pharmacodynamics of prednisolone in the rat. *J. Pharmacokin. Biopharm.* 14, 469-494.

## ALTERNATIVE APPROACHES IN MEDIAN LETHALITY (LD<sub>50</sub>) AND ACUTE TOXICITY TESTING

Linval R. DePass

*Department of Toxicology, Institute of Toxicologic Sciences*

*Syntex Research, Palo Alto, CA*

### SUMMARY

The LD<sub>50</sub> test was introduced by Trevan in 1927 [1] for biological standardization of dangerous drugs. Since then, the LD<sub>50</sub> has gained wide acceptance as a measure of acute toxicity of all types of substances. Recently, however, the LD<sub>50</sub> test has been criticized as an unnecessary waste of resources. Therefore, efforts have been made to reduce the number of animals used in such tests and to avoid using this test unless required by regulations. A review of the literature has shown that a relatively small number of animals per dose level (5) and a small number of dose levels (2 or 3) are usually sufficient to calculate an LD<sub>50</sub> and slope using moving average methods. In addition, one sex should suffice because large sex differences are seldom encountered. When a formal LD<sub>50</sub> is not required, one of several approximate methods may be used to estimate the lethal dose. Further approaches include *in vitro* cytotoxicity methods and computer-based structure-activity models. The *in vitro* methods are still in an early stage of development and will require extensive validation before they are accepted by the toxicology community. In conclusion, when LD<sub>50</sub> tests are required, the most economical approach should be used, without undue concern for statistical precision.

### INTRODUCTION

The LD<sub>50</sub> test was introduced by Trevan in 1927 [1] for biological standardization of potent and potentially dangerous drugs such as digitalis extracts, insulin, and diphtheria toxin. For this purpose, high precision was essential, and this required relatively large numbers of animals. In the years since its introduction, the LD<sub>50</sub> test has been used to evaluate the acute toxicity of a wide variety of chemical substances including drugs, pesticides, industrial chemicals, cosmetics, and food additives. For these purposes, a high degree of precision usually is not required.

In recent years, the LD<sub>50</sub> test has been widely criticized as an unnecessary waste of resources, especially in relation to the large number of animals used. Many investigators, including Weil [2], Zbinden and Fluri-Reversi [3], Muller and Kley [4], Schutz and Fuchs [5], Lorke [6], and Depass et al. [7] have shown that adequate information about the lethal dose of a substance may be obtained using far fewer animals than required by classical LD<sub>50</sub> methods.

In this article, the purposes of LD<sub>50</sub> and acute toxicity tests will be reviewed. The importance of various factors such as sex, sample size, number of dose levels, method of LD<sub>50</sub> and slope calculation, and skin abrasion in percutaneous application studies will be assessed, especially as they affect the number of animals used in LD<sub>50</sub> studies. Approximate methods for estimating lethal dose requiring very small numbers of animals (6 to 10 per test) will be reviewed. Finally, possible future approaches will be summarized.

#### **PURPOSES OF LD<sub>50</sub> AND ACUTE TOXICITY TESTS**

It should be stated from the outset that a well-conducted "LD<sub>50</sub> test" should provide considerably more information about the toxicity of a substance than an estimate of the median lethal dose. Zbinden [8] has reviewed the purposes of acute toxicity testing from a historical perspective. It is clear that our perception of the reasons for performing such studies has changed over the years since their introduction. For example, the use of this test as a means of standardizing drug potency is now obsolete. Similarly, the calculation of a therapeutic index for drugs (i.e., the ratio of the LD<sub>50</sub> to the ED<sub>50</sub> for the desired effect) now is considered to have very limited value. The ED<sub>50</sub> should be compared not to the LD<sub>50</sub>, but rather to the lowest dose that produces a significant toxic effect.

Information from LD<sub>50</sub> tests has often been used to select doses for subsequent repeated-dose toxicity studies. A well-conducted acute toxicity test can provide useful information for dose selection. Because LD<sub>50</sub> tests are usually the first investigations of the effects of industrial chemicals on mammals, these tests very often do provide valuable data for selecting doses for subsequent studies. This situation does not exist, however, for human pharmaceuticals, in that pharmacology data are usually available prior to initiating toxicology studies. For other classes of compounds, such as cosmetic ingredients, food additives, and contaminants (including animal drugs and their metabolites), it is difficult to justify the need for studies designed to investigate the effects of single large doses because such exposures rarely will occur in humans.

Useful information on the bioavailability of a compound may sometimes be obtained from LD<sub>50</sub> studies by comparing LD<sub>50</sub> values with different routes of administration. Although LD<sub>50</sub> studies clearly cannot provide as much information as well-conducted pharmacokinetic studies, one may still conclude that a compound that is as toxic by oral gavage as by intravenous injection is absorbed well from the gastrointestinal tract.

Results of LD<sub>50</sub> tests have been used to predict lethal doses and symptomatology of human intoxications. Because LD<sub>50</sub> values may vary greatly among different species, prediction of human lethal doses from rodent LD<sub>50</sub>s should be made with caution. Nevertheless, well-conducted acute toxicity tests can provide useful information about the kind of toxicity to be expected.

Acute LD<sub>50</sub> tests are or have been required by various U.S. regulatory agencies to provide essential information on the potential toxicity of chemical substances. The Food and Drug Administration (FDA) has required such data to support registration of pharmaceutical, food additives, and cosmetic ingredients. However, this agency issued a policy statement on October 11, 1988, indicating that the "classical LD<sub>50</sub> test is not a required toxicity study" [9]. This position was confirmed more recently by the Director of FDA's Center for Veterinary Medicine [10]. Similarly, the Environmental Protection Agency (EPA) has required this test for registration of pesticides and sometimes for other industrial chemicals. In a very recent announcement, the EPA suggested that abbreviated tests be used when appropriate [11]. The Department of Transportation and the Consumer Product Safety Commission also require limited LD<sub>50</sub> data to establish the safety of substances transported across state lines and for various commercial products, respectively.

Hickey [12] published the results of a survey of various manufacturers of industrial chemicals, cosmetics, and pharmaceuticals. The responses indicated that most of the companies performed acute toxicity tests, including traditional LD<sub>50</sub> tests, and that the great majority of such tests were performed to satisfy regulatory requirements. Although a majority of the companies used a limit test, only a minority reported using an approximate lethal dose test.

#### **FACTORS IN THE DESIGN OF LD<sub>50</sub> TESTS**

##### **Sex**

Although animals of both sexes are used routinely in most toxicology studies, there is evidence that one sex may be sufficient for LD<sub>50</sub> tests. Weil et al. [2] reported the results of 143 rat oral LD<sub>50</sub> tests performed using both sexes. They reported mean LD<sub>50</sub> values of 8.36 and 8.96 g/kg, respectively, for males and females, and a correlation coefficient of 0.961. In only 8 of the 143 tests was the LD<sub>50</sub> significantly different for the two sexes. Therefore, for this large group of predominantly aliphatic organic compounds, the sex difference was not important.

Muller and Kley [4] reported the results of 152 LD<sub>50</sub> tests, 81 in mice and 71 in rats. These tests were conducted with drugs administered either orally or by intravenous injection. A significant difference in LD<sub>50</sub> for male and female animals was found in only 23 of the 152 determinations, with the male LD<sub>50</sub> being higher in 17 of the 23 cases.

In a similar study, Schutz and Fuchs [5] reported the results of 170 LD<sub>50</sub> tests in rats, mice, and guinea pigs. Drugs of various classes were administered by oral and parenteral routes. A significant sex difference was found in only 3 of the 170 determinations.

DePass et al. [7] summarized the results of 91 rat oral LD<sub>50</sub> tests and reported mean LD<sub>50</sub> values of 2.47 and 2.13 g/kg for males and females, respectively. The correlation coefficient was 0.93,

indicating a strong association between male and female LD<sub>50</sub> values for this large array of industrial chemicals. Somewhat surprisingly, this small difference was statistically significant ( $p = 0.0002$ ), indicating that the male LD<sub>50</sub> values were consistently higher than the female values. Nevertheless, a difference of this magnitude has no biological importance. DePass et al. [7] also analyzed the sex difference data from rabbit dermal studies in which the compounds were applied to abraded or unabraded skin. For 28 studies using unabraded skin, the mean LD<sub>50</sub> values were 3.15 and 2.81 g/kg for males and females, respectively, with a correlation coefficient ( $r$ ) of 0.96. Again, this sex difference was statistically significant ( $p = 0.03$ ) but not biologically meaningful. Corresponding values for abraded skin were 0.93 and 0.94 for  $n = 17$  and  $r = 0.73$ . Finally, Bruce [13] reported the results of 48 rat oral LD<sub>50</sub> tests with various household products. For these studies, the LD<sub>50</sub> value for males averaged 29% higher than that for females. In 13 of the 48 cases, the male values were significantly ( $p < 0.05$ ) higher than the female.

The results summarized above indicate that sex differences are usually not important in LD<sub>50</sub> studies. Although the rat oral data of Bruce [13] and DePass et al. [7] suggest that females may generally be more sensitive than males, the sex differences reported were usually within the limits of reproducibility of the LD<sub>50</sub> bioassay and, therefore, not biologically significant.

#### ***Number of Animals per Dose Level***

The number of animals required at each dosage level of an LD<sub>50</sub> study has been the subject of discussion for many years. Weil et al. in 1953 [2] summarized the results of rat oral LD<sub>50</sub> data for 24 compounds. The mean LD<sub>50</sub> values were 4.64 and 4.76 g/kg for  $n = 5$  and  $n = 10$ , respectively, with a correlation coefficient of 0.988. For percutaneous LD<sub>50</sub> tests in rabbits they reported mean LD<sub>50</sub> values of 3.03 and 3.17 g/kg for  $n = 4$  and  $n = 5$ , respectively, with a correlation coefficient of 0.977.

Schutz and Fuchs [5] analyzed data from 170 LD<sub>50</sub> tests involving three rodent species and five routes of administration. They compared LD<sub>50</sub> values and confidence intervals when 4, 6, 8, or 10 animals were used at each dosage level. Their results indicated that, in most cases, acceptable LD<sub>50</sub> values could be calculated even with four animals per dose group. DePass et al. [7] analyzed rat oral LD<sub>50</sub> data for 11 compounds tested in both sexes. They found the mean LD<sub>50</sub> values to be essentially identical whether 5 or 10 animals were used at each dosage level. The correlation coefficient was 0.98 for each sex.

These data indicate that acceptable LD<sub>50</sub> values can be obtained using no more than five animals per dosage level. Doubling the number of animals results in no significant gain with respect to our knowledge of the acute toxicity of most compounds.



### ***Number of Dosage Levels***

The number of animals used in LD<sub>50</sub> studies depends, not only on the number treated at each dosage level, but also on the number of dosage levels. The importance of the latter variable is more difficult to evaluate since it is usually dependent on the method used for determining the LD<sub>50</sub>. For example, the classical probit method typically requires relatively large numbers of animals compared with certain other methods such as the moving average method. Schutz and Fuchs [5] using the probit method found that five or more dosage levels were needed in 57% of rat oral studies, 31% of rat intravenous (iv) studies, 55% of mouse oral studies, and 41% of mouse iv studies.

To evaluate the importance of number of dosage levels of LD<sub>50</sub> data, it is necessary to vary this number while using a single method for calculating the LD<sub>50</sub>. Using this approach, DePass et al. [7] calculated rat oral LD<sub>50</sub> values for 10 compounds (mostly insecticides) using the minimum number of dosage levels required for the moving average method (2 or 3 levels). They then added dosage levels as needed to calculate LD<sub>50</sub> values by the probit method. The latter method required three to seven dosage levels for these compounds. Finally, they calculated LD<sub>50</sub> values for both data sets using the moving average method. The resulting LD<sub>50</sub>s showed excellent agreement with a correlation coefficient of 0.99 between the two sets of data. Therefore, based on this admittedly small data set, there was no advantage to using approximately twice as many dosage levels as the minimum required by the moving average method.

### ***Method of LD<sub>50</sub> and Slope Calculation***

Several methods have been used for calculating the LD<sub>50</sub> and the slope of the dose-lethality curve. While it is beyond the scope of this paper to review and compare the various methods, it is very useful to evaluate the differences in resources required by certain methods. For example, the widely accepted probit method [14] provides statistically precise estimates of the LD<sub>50</sub> and the slope. The main disadvantage is that relatively large numbers of animals must be treated at doses close to the LD<sub>50</sub> to obtain adequate goodness of fit. Doses that produce 0 or 100% mortality cannot be used in these calculations. Thus, it is rare that three or fewer dosage levels are adequate for an LD<sub>50</sub> determination (see Schutz and Fuchs [5] data cited above). By contrast, the moving average method [15] requires relatively few animals (usually 10 to 20), does not exclude 0 or 100% mortality data, and does not assume a linear dose-lethality curve. The main disadvantage is a relative lack of precision when small numbers of animals are used. In addition, there was originally no method for calculating a slope as required by some regulatory agencies. This deficiency no longer exists since the publication of a method for slope calculation based on the moving average method [16].

To compare the results of LD<sub>50</sub> determinations using these two methods, DePass et al. [7] analyzed data from eight rat oral studies. The results indicated very strong association ( $r = 0.99$ )

between the LD<sub>50</sub> values calculated by these very different methods. A comparison of the slopes yielded a similar correlation except that the moving average slope was generally significantly larger than that calculated by the probit method. In a similar comparison of slopes using a larger data base (35 dose-response curves), Weil [16] reported a correlation coefficient of 0.85. Although caution is necessary when attempting to make general inferences from a limited data base, it is clear that very different approaches can yield very similar LD<sub>50</sub> and slope data.

#### ***Skin Abrasion in Percutaneous Studies***

Because regulatory agencies have requested LD<sub>50</sub> data on compounds applied to intact as well as to abraded skin, the effect of abrasion on toxicity is of interest, especially since relatively expensive rabbits are often used in dermal studies. DePass et al. [7] compared LD<sub>50</sub> values for 20 compounds applied to both intact and abraded skin of rabbits. The values were generally higher for intact than for abraded skin, as one would expect if abrasion enhances penetration of the compound. Correlation coefficients were 0.54 and 0.66 for males and females, respectively, indicating only modest association between these variables. It is possible that variation in the abrasion technique contributed to differences in the extent of enhancement of skin penetration, resulting in the relatively weak correlations observed.

#### **APPROXIMATE LD<sub>50</sub> METHODS**

Whereas the probit and moving average methods are well known and accepted by regulatory agencies, other methods are available that provide useful information about acute toxicity including estimates of a lethal dose or LD<sub>50</sub>. These "approximate" methods have the disadvantage that they may not be acceptable to some regulatory agencies. Their advantage is that they are very economical in the number of animals used.

#### ***Approximate Lethal Dose Method (Deichmann)***

The oldest of the methods to be described was published by Deichmann and LeBlanc in 1943 [17], which has recently received renewed interest. In this procedure, an arbitrary dose of the test substance is administered to one animal. If the animal survives, a second animal receives 1.5 times the previous dose. In this manner, increasing doses are administered until a lethal dose is achieved. This lowest lethal dose is called the Approximate Lethal Dose (ALD). The major advantage of this procedure is that only 6 to 10 animals are required for each test.

In 1948, Deichmann and Mergard [18] published an evaluation of this method in which they compared the ALD with a traditional LD<sub>50</sub> for a series of compounds having greater than a 100-fold range in lethal dose. There was good agreement between the ALDs and the traditional LD<sub>50</sub>s with a correlation coefficient of 0.98. Kennedy et al. [19] used the same approach to compare ALDs with

conventional LD<sub>50</sub>s for nine compounds. The results are shown in Table 1. Their results showed good agreement between the two methods. The average number of rats needed was 6.8 for the ALD versus 56.3 for the complete LD<sub>50</sub>.

**TABLE 1. APPROXIMATE LETHAL DOSE (ALD) VERSUS CONVENTIONAL RAT ORAL LD<sub>50</sub> (g/kg)**

Chemical	Conventional		Approximate	
	N	LD <sub>50</sub>	N	ALD
Tetraethyl lead	36	20	5	26
Methomyl	53	40	5	26
Hexachlorophene	46	165	11	90
Adiponitrile	65	301	7	300
Caffeine	40	483	8	450
N-Butylhexamethylene diamine	35	536	7	1,000
Hexamethylene diamine	92	1,127	5	1,500
Bromobenzene	35	3,591	8	3,400
Carbon tetrachloride	105	10,054	5	7,500

(Kennedy et al., 1986) [19]

#### ***Up-and-Down Method (Dixon and Mood; Bruce)***

The up-and-down method was introduced by Dixon and Mood [20] and was recently revisited by Bruce [13, 21]. In this method, animals are dosed one at a time starting at an estimated LD<sub>50</sub> dose. If the first animal survives, the next animal receives a higher dose. If the first animal dies, the next animal receives a lower dose. Doses are usually adjusted by a constant multiplicative factor such as 1.3. The dose for each successive animal is adjusted up or down depending upon the outcome of the previous animal. Bruce [13] performed computerized simulations of this method for 10 substances and compared the results with conventional probit-derived LD<sub>50</sub> data. The up-and-down results showed excellent agreement with the formal LD<sub>50</sub> dose. In a confirmatory study [21], 10 substances were tested in parallel using both methods. The results are summarized in Table 2. Again there was excellent agreement between the results of the two methods. Whereas the conventional method used 40 to 50 animals per test, the up-and-down method required only 6 to 9.

TABLE 2. UP-AND-DOWN METHOD VERSUS CONVENTIONAL RAT ORAL LD<sub>50</sub> (g/kg)

Chemical No.	Conventional		Up-and-Down	
	N	LD <sub>50</sub>	N	LD <sub>50</sub>
1	50	0.273	6	0.388
2	40	0.344	9	0.421
3	40	3.49	8	4.12
4	40	3.51	6	4.02
5	40	4.04	6	3.52
6	40	5.56	6	5.70
7	40	9.28	6	8.77
8	20	> 10	3	> 10.1
9	50	10.11	7	11.09
10	10	> 20	8	22.4

(Bruce, 1987) [13]

#### ***Molinengo Method***

Another approximate method for determination of the LD<sub>50</sub> was proposed by Molinengo [22]. This method is based on an empirical relationship between dose and survival time. The dose (D) is plotted as a function of D/T, where T = survival time. The resulting function is described by the linear equation  $D = aD/T + b$ . The y-intercept, b, where the regression line intersects the ordinate, is the smallest dose that kills 50% of the animals in an unlimited time, and represents an approximate LD<sub>50</sub>. Molinengo [22] reported good agreement between approximate and conventional LD<sub>50</sub> data for several drugs tested in female mice. Only 6 to 11 mice were used for each test.

Although this method may yield reasonable approximations of the LD<sub>50</sub> for some compounds, more recent data show less impressive agreement between the Molinengo LD<sub>50</sub>s and classical LD<sub>50</sub>s [23]. This method has been criticized because of its relatively large variability, even compared with other approximate methods such as the up-and-down method [24]. The Molinengo method also has been criticized on theoretical grounds in that the dependent variable (T) appears on the abscissa [24, 25]. This violates one of the premises of linear regression; namely, that all of the error be expressed on the ordinate.

#### ***British Toxicology Society Protocol***

The British Toxicology Society (BTS) has proposed a protocol for acute toxicity testing that minimizes the number of animals used as well as their pain and distress [26]. In this approach the animals receive 5, 50, or 500 mg/kg body weight.

The initial dose is chosen, based on available information, to produce toxicity but no mortality. Depending on the observed response, the dose is either increased or decreased by a factor of 10. Five rats of each sex are tested at each dose level. Substances are assigned to one of four toxicity classes based on the percent survival and signs of toxicity at a given dose. Results of a comparative study indicated that 31 of 41 compounds were classified correctly when this protocol was compared with the standard OECD protocol [26]. The BTS protocol used only 36% of the number of animals required by the OECD protocol, and the percent mortality was only 13% of the number that died with the latter protocol.

#### **Other Methods**

Other approaches to determination of the LD<sub>50</sub> using small numbers of animals have been published in recent years. The Noordwijk method [27] is a refinement of the Deichmann ALD procedure, whereas the Lorke procedure [6] is another sequential method. These methods will receive more credence when they have been subjected to independent validation.

#### **FUTURE APPROACHES**

Whereas even the approximate methods described above still depend on the use of animals, other approaches have been developed that rely on structure-activity relationships in *in vitro* cell culture data to predict acute toxicity.

Enslein and Craig [28] have developed a computerized statistical model for predicting LD<sub>50</sub>s. Although this approach will require additional independent validation, the wealth of LD<sub>50</sub> data available on a broad range of substances suggests that this may be one area of toxicology in which animal studies eventually may be replaced by computer-calculated values.

Significant efforts also have been directed in recent years to development of *in vitro* methods for prediction of acute toxicity [29]. As with the computerized structure-activity predictions, these methods must be validated independently using a broad range of substances before they can be considered as replacements in *in vivo* studies.

#### **DISCUSSION AND CONCLUSIONS**

Because of the inherent limitations in the value of LD<sub>50</sub> data and because of the need to conserve animal resources, the routine use of large numbers of animals to calculate statistically precise LD<sub>50</sub>s can no longer be justified. This position has been taken by the FDA and the EPA, which no longer require classical LD<sub>50</sub> data. In fact, the EPA has formally endorsed the approximate lethal dose, up-and-down, and moving average methods described above [11]. Their recently revised policy also suggests that only the more sensitive sex is required. Other international regulatory agencies, including the Japanese Ministry of Health and Welfare, have also reduced or eliminated their

requirements for LD<sub>50</sub> data. This change of attitude toward LD<sub>50</sub> data does not imply that there is no longer any value in determining the potential toxicity of single large doses of a substance. Such data can be very useful in characterizing toxicity and in designing future experiments. The necessary information can be obtained with relatively small numbers of animals by using one of the approximate methods described above. When regulatory requirements insist on more traditional approaches, it is still possible to produce credible LD<sub>50</sub> data while using small numbers of animals (less than 20 per test). This may be accomplished by using the moving average method, which can provide an estimate of the LD<sub>50</sub> with confidence limits and/or a slope, when required.

It should be clear from the preceding discussions that there is no universally recognized ideal protocol that can provide acceptable LD<sub>50</sub> data while also minimizing the use of animals. Within the foreseeable future, the approximate methods may be deemed acceptable by all regulatory agencies around the world. Until that time, however, we are faced with the challenge of developing protocols that are economical in use of animals and yet acceptable to regulatory authorities. The following protocol is proposed as one approach that may be acceptable to all parties involved in the safety evaluation of chemical substances. When using this protocol, or any other protocol for acute toxicity studies, it is essential that nonlethal endpoints, such as clinical signs, be recorded and evaluated.

#### ***Proposed Acute Toxicity Protocol***

- Assuming that no previous *in vivo* studies have been performed, use structure-activity relationships and/or *in vitro* data to predict acute toxicity of the substance.
- For compounds other than human pharmaceuticals, use limit test doses (5 g/kg oral, 2 g/kg dermal), unless there is reason (from step 1) to suspect that these doses will be excessive.
- For human pharmaceuticals, give 100 times the expected clinical dose (or ED<sub>50</sub> in an appropriate animal model), unless there is reason to expect excessive toxicity at this dose.
- Treat five animals of a single sex and species, preferably females, because they may be generally more sensitive than males.
- If no mortality or significant clinical signs are observed at the limit dose, stop the experiment. The substance may be classified as having low acute toxicity.
- If fractional mortality (less than 100%) and/or significant clinical signs occur, reduce the dose by a factor of 2. Continue this process to define a nonlethal and, hopefully, a no-observed-effect level (NOEL).
- If 100% mortality occurs, reduce dose by factor of 10, because the LD<sub>50</sub> clearly has been exceeded. Depending on the result at the lower dose, additional doses may have to be increased or decreased by an appropriate factor so that an LD<sub>50</sub> can be calculated by the moving average method.
- Dose a group of males at the estimated LD<sub>50</sub> to determine whether there is a significant sex difference in toxicity. The protocol would be repeated only if the result were markedly different (e.g., 0 or 100% mortality).

With this protocol, an LD<sub>50</sub> with confidence limits and/or slope should be obtainable with 20 animals or less for most substances. The most difficult substances to study with a limited sequential protocol such as this are those that cause delayed deaths or that have relatively flat dose-lethality curves. These substances would have to be considered for more complete studies on a case-by-case basis. Because most deaths occur within one week of dosing, this period should be adequate for most compounds. If a compound produces delayed deaths, the more standard two-week observation period should be used.

As a final comment, we may ask whether the need to protect the public requires the administration of lethal doses to animals? All regulatory agencies now agree that it is unnecessary to determine lethal doses in large nonrodent species such as dogs and monkeys. In the future, it may be necessary only to administer large enough doses to characterize the toxicity of a compound in acute toxicity studies.

#### REFERENCES

- 1 Trevan, J.W. (1927) The error of determination of toxicity. Proc. R. Soc. (London) Ser. B. 101, 483-514.
- 2 Weil, C.S., Carpenter, C.P. and Smyth, H.F. (1953) Specifications for calculating the median effective dose. Am. Ind. Hyg. Assoc. Quar. 14, 200-206.
- 3 Zbinden, G. and Fluri-Reversi, M. (1981) Significance of the LD<sub>50</sub> test for the toxicological evaluation of chemical substances. Arch. Toxicol. 47, 77-99.
- 4 Muller, H. and Kley, H.P. (1982) Retrospective study on the reliability of an "approximate LD<sub>50</sub>" determined with a small number of animals. Arch. Toxicol. 51, 189-196.
- 5 Schutz, E. and Fuchs, H. (1982) A new approach to minimizing the number of animals used in acute toxicity testing and optimizing the information of test results. Arch. Toxicol. 51, 197-228.
- 6 Lorke, D. (1983) A new approach to practical acute toxicity testing. Arch. Toxicol. 54, 275-287.
- 7 DePass, L.R., Myers, R.C., Weaver, E.V. and Weil, C.S. (1984) An assessment of the importance of number of dosage levels, number of animals per dosage level, sex, and method of LD<sub>50</sub> and slope calculation in acute toxicity studies. In: A.M. Goldberg (Ed.), Acute Toxicity Testing: Alternative Approaches, Vol. 2, Mary Ann Liebert, Inc., New York, pp. 139-153.
- 8 Zbinden, G. (1984) Acute toxicity testing, purpose. In: A.M. Goldberg (Ed.), Acute Toxicity Testing: Alternative Approaches, Vol. 2, Mary Ann Liebert, Inc., New York, pp. 3-22.
- 9 Food Chemical News, Oct. 17, 1988, pp. 53-54.
- 10 Food Chemical News, Jan. 9, 1989, pp. 36-37.
- 11 NABR Update, Dec. 13, 1988, Vol. 9, No. 26.

- 12 Hickey, T.E. (1984) Acute toxicity testing, practice. In: A.M. Goldberg (Ed.), Acute Toxicity Testing: Alternative Approaches, Vol. 2, Mary Ann Liebert, Inc., New York, pp. 23-45.
- 13 Bruce, R.D. (1985) An up-and-down procedure for acute toxicity testing. *Fundam. Appl. Toxicol.* 5, 151-157.
- 14 Bliss, C.I. (1938) The determination of the dosage-mortality curve from small numbers. *Q.J. Pharm. Pharmacol.* 11, 192-216.
- 15 Thompson, W.R. (1947) Use of moving averages and interpolation to estimate median effective dose. *Bacteriol. Rev.* 11, 115-145.
- 16 Weil, C.S. (1983) Economical LD<sub>50</sub> and slope calculation. *Drug and Chem. Toxicol.* 6, 596-603.
- 17 Deichmann, W.B. and LeBlanc, T.J. (1943) Determination of the approximate lethal dose with about six animals. *J. Ind. Hyg. Toxicol.* 25, 415-417.
- 18 Deichmann, W.B. and Mergard, E.G. (1948) Comparative evaluation of methods employed to express the degree of toxicity of a compound. *J. Ind. Hyg. Toxicol.* 30, 373-378.
- 19 Kennedy, G.L., Jr., Ferenz, R.L. and Burgess, B.A. (1986) Estimation of acute oral toxicity in rats by determination of the approximate lethal dose rather than the LD<sub>50</sub>. *J. Appl. Toxicol.* 6, 145-148.
- 20 Dixon, W.J. and Mood, A.M. (1948) A method for obtaining and analyzing sensitivity data. *J. Am. Stat. Assoc.* 43, 109-126.
- 21 Bruce, R.D. (1987) A confirmatory study of the up-and-down method for acute toxicity testing. *Fundam. Appl. Toxicol.* 8, 97-100.
- 22 Molinengo, L. (1979) The curve doses vs. survival time in the evaluation of acute toxicity. *J. Pharm. Pharmacol.* 31, 343-344.
- 23 Meier, J. and Theakston, R.D.G. (1986) Approximate LD<sub>50</sub> determinations of snake venoms using eight to ten experimental animals. *Toxicon* 24, 395-401.
- 24 Sevcik, C. (1987) LD<sub>50</sub> determination: objections to the method of Beccari as modified by Molinengo. *Toxicon* 25, 779-783.
- 25 Finney, D.J. (1985) The median lethal dose and its estimation. *Arch. Toxicol.* 56, 215-218.
- 26 van den Heuvel, M.J., Dayan, A.D. and Shillaker, R.O. (1987) Evaluation of the BTS approach to the testing of substances and preparations for their acute toxicity. *Hum. Toxicol.* 6, 279-291.
- 27 van Noordwijk, A.J. and van Noordwijk, J. (1988) An accurate method for estimating an approximate lethal dose with few animals, tested with a Monte Carlo procedure. *Arch. Toxicol.* 61, 333-343.
- 28 Enslein, K. and Craig, P.N. (1987) A toxicity estimation model. *J. Environ. Pathol. Toxicol.* 2, 115-121.
- 29 Balls, M. and Horner, S.A. (1985) The FRAME interlaboratory programme on *in vitro* cytotoxicology. *Food Chem. Toxicol.* 23, 209-213.



## TRIGGERS FOR HIGHER ORDER TOXICITY TESTING

Bernard A. Schwetz and Richard E. Morrissey

*Division of Toxicology Research and Testing, National Institute of Environmental Health Sciences*

*P.O. Box 12233, Research Triangle Park, NC 27709*

### SUMMARY

Strategies for selecting chemicals for definitive, higher order toxicology tests are important because physical and personnel resources are limited and chemicals vary widely in the need for testing. The National Toxicology Program has developed strategies for selection of chemicals for definitive tests in several areas of toxicology. In addition to the number of people, the extent of human exposure, structure-activity considerations, and reports of observations in humans, specific triggers are sought from animal studies and short-term tests or *in vitro* screening that impact the chemical selection process and the design of definitive studies. Specific triggers in reproductive toxicology, for example, include observations in prechronic toxicology studies in rats and mice: weights and histopathologic examinations of reproductive organs, measurements of sperm production and function in males, and estrus cyclicity in females. Comparable tissue-specific triggers do not exist for developmental toxicity studies, and screening tests are not widely used for setting priorities for the conduct of definitive developmental toxicology studies.

### INTRODUCTION

This paper will deal with the progression of toxicological testing from prescreens through screens, definitive studies, and supportive or interpretative studies. The intent of this paper is to challenge the reader regarding the issue of whether the toxicological studies being conducted are really definitive studies or whether they are, in fact, screening studies. Also, information is presented on the results of a review of studies of the National Toxicology Program (NTP) regarding the use of screens or trigger information in the area of reproductive toxicology.

### TRIGGERS FOR TOXICITY TESTING

Scientists concerned about the potential adverse public health effects of chemicals in our environment focus primarily on the endpoints listed in Table 1. These endpoints of concern are listed in the context of the triggers or considerations that establish the relative amount of concern we have for each of these areas of toxicity. For example, one of the major public health concerns in the world today is carcinogenesis. The triggers that drive this concern include structure-activity relationship considerations for individual chemicals, as well as the results of subchronic toxicity studies; the fact that people are exposed on a chronic basis is a major stimulus for concern over carcinogenesis. In addition, positive results of prescreens for genetic toxicity or other nongenetic endpoints that could

potentially result in carcinogenicity are also triggers. As for carcinogenesis, the triggers for our concern over the toxicity associated with chronic exposure to chemicals include the chemical structure, the results of subchronic toxicity studies, as well as the chronic exposure of people. In contrast with the concern over carcinogenicity, however, factors of great importance regarding chronic toxicity are the potential of a chemical to cause delayed toxicity, due either to cumulative toxicity or the potential of the chemical to accumulate in the body to toxic levels over prolonged periods of exposure. Chemicals with long biological half-lives are more likely to cause toxic effects upon long-term exposure to low levels than chemicals where the biological half-life is short and the results of short-term toxicology studies predict well the dose levels at which effects will be seen from chronic exposure.

TABLE 1. TRIGGERS AND RELATED TOXICITIES OF CONCERN

Triggers	Concern						
	Oncogenicity	Chronic Toxicity	Heritable Genetic Damage	Devel- opmental Toxicity	Repro- ductive Toxicity	Neuro- toxicity	Immuno- toxicity
Structure activity relationships	X	X	X	X	X	X	X
Subchronic study results	X	X			X	X	X
Chronic study results					X	X	X
Exposure: acute or short			X	X		X	X
chronic	X	X			X		
Positive prescreens:							
genetic	X		X				
nongenetic	X			X			
Delayed toxicity		X				X	
Long biological half-life		X					
Women exposed				X			
Developmental toxicity					X		

The main triggers for concern over heritable genetic damage include the chemical structure as well as positive results from genetic toxicity screens. While genetic damage can occur from exposure of any duration, the greatest concern is from acute exposure to large amounts of chemicals.

While the areas of reproductive and developmental toxicity often are thought of as being closely associated, the closeness may be more important organizationally than it is conceptually. This difference is reflected in the triggers of concern for these two areas (Table 1). In the area of developmental toxicology, structure-activity relationships have been useful in the past in predicting this endpoint of toxicity across chemical classes. Because of the narrow window of susceptibility for

teratogenesis or developmental toxicity, the duration of greatest concern is an acute short-term repeated exposure rather than chronic exposure. Other triggers for concern are the positive results of prescreens developed to predict teratogenic effects as well as the existence of situations where women are exposed to the chemical. Regarding concern over reproductive toxicity, structure-activity relationships are important along with the results of either subchronic toxicity studies. In both of these studies, examinations of reproductive organs are important triggers for the potential of that chemical to cause adverse reproductive effects. In contrast to developmental toxicity where the exposure of concern is acute, the greatest concern regarding reproductive toxicity is from chronic exposure. In some cases, where the results of a developmental toxicity study show a significant reduction in fetal body weight or a significant decrease in litter size, the results of a developmental toxicity study also can be a significant trigger for concern over reproductive effects.

The triggers for concern over neurotoxicity and immunotoxicity are similar in some regards, in that both are triggered by chemical structure, the results of subchronic and chronic studies, and the major concern is from acute or short-term exposure. In both cases, however, chronic exposure also can be of great importance in causing these forms of toxicity. One aspect of neurotoxicity is that acute exposure can result in delayed manifestations of toxicity, a response pattern that is sometimes confused with the outcome of chronic exposure.

### ***Strategies for Carcinogenicity Tests***

Two different approaches to carcinogenicity testing are shown in Table 2. The major question in this specific area of concern is whether the two-year carcinogenicity studies (which are frequently erroneously referred to as "bioassay") are in fact a screen or a definitive study for carcinogenic potential. During the early days of the bioassay program, the National Cancer Institute used the two-year rodent carcinogenicity study as a screen for carcinogenic potential with the intent that definitive studies would be conducted on those chemicals that caused positive results. Unfortunately, the definitive studies were seldom conducted as a sequel to the screens. Instead, we have expanded these two-year screens to the extent that they use more animals and dose levels than in the past, and many questions beyond carcinogenic potential are introduced into the design of these studies such that they are no longer just a screen for carcinogenesis. In addition to carcinogenicity, we attempt to get information regarding chronic toxicity and include groups of animals for special stop-studies or start-studies or for information regarding complete carcinogenesis vs. promotion. Because of the great cost and the long period of time required to do these studies, it is hard to consider that they are simply a screen for carcinogenicity. Another consequence of using the two-year rodent studies as we do today is that by the time these studies are completed, most toxicologists or laboratories are unwilling to afford the great cost of doing additional complex testing for carcinogenic potential after conducting a two-year rodent "screen." As a result, definitive studies for carcinogenic potential that

are designed to better understand the pathogenesis and biology of carcinogenesis in the rodent model are seldom conducted today. A real problem, though, with using the two-year study as a screen, followed with a second two-year study for more definitive data, is the 8 to 10 years required to run these studies in sequence. If a chemical is carcinogenic, that is a long time to test a hypothesis before making a public health decision.

**TABLE 2. TWO-YEAR CARCINOGENICITY STUDIES: SCREEN OR DEFINITIVE STUDY?**

<b>CARCINOGENESIS</b>		
<b>Prescreen</b>	<b><i>In vitro</i> genetic toxicity studies</b>	
<b>Screen</b>	<b>A. Two-year rodent study</b>	<b>B. Two-year bioassay promotion models</b> Strain A mice Transgenic mice
<b>Definitive study</b>		<b>Two-year rodent study</b> Interim sac Stop-study Multi-dose, large groups
<b>Mechanistic and interpretative studies</b>	Chemical disposition Oncogene activation Cell turnover DNA damage Promotion models Metabolic activation	

As shown in Table 2, perhaps the two-year rodent studies should be redesigned with the intent that they would serve as a definitive study for carcinogenicity and other studies would be used as a screen. Such studies might include a true two-year rodent bioassay per the original intent, or other studies of duration shorter than two years such as promotion models, tests in Strain A mice, or perhaps studies in the future using transgenic mice where carcinogenic effects might be obtained in periods of time considerably less than two years.

Whether two-year rodent studies are considered a screen or a definitive study in the future, other studies that provide us information about the mechanism of toxicity or help us interpret the results of carcinogenicity studies include those shown in Table 2. Chemical disposition studies, data regarding activation of oncogenes, and data that relate to rate of cell turnover and other evidence of cytotoxicity to the probability of a chemical causing cancer by nongenetic means are important. Data regarding the potential of a chemical to cause DNA damage or other evidence of genetic toxicity should be used in conjunction with the data describing the relative cytotoxicity of the dose levels at which carcinogenic effects are seen. Promotion models, especially those that are specific for the site of the carcinogenic effects seen in two-year studies, are helpful in understanding the potential mechanism by which carcinogenic effects are caused. Also, the role of metabolism in the cause of

carcinogenesis is an important contribution of our understanding and the means of extrapolation of animal data to humans.

### ***Strategy for Reproductive and Developmental Toxicity Tests***

Within the NTP, a strategy has been developed and implemented regarding the acquisition of information (triggers) from subchronic toxicity studies that are useful in setting priorities for the conduct of reproductive toxicity tests. Specific measurements are made at the termination of prechronic studies in rats and mice that are helpful in predicting the likelihood of a chemical causing a reproductive effect in either males or females and that aid in the design of the continuous-breeding reproduction studies. The protocol is used as the definitive study for reproductive toxicity by the NTP. Data that are collected, in addition to the routine histopathologic examination of reproductive organs of both males and females, include, in the males, epididymis weight, testis weight, sperm motility, sperm concentration, and sperm morphology examinations, and, more recently, testicular spermatid head count. The procedures and the results of these examinations are summarized in two recent publications [1, 2]. In addition to these observations in males, during the last week of prechronic toxicity studies, the cyclicity of females is measured through examination of vaginal smears. As an additional measure of the potential effect on females, the NTP also has been examining the ovaries of females from continuous breeding reproduction studies to examine folliculogenesis in the same sense that we and other laboratories examine the effect of chemicals on spermatogenesis. In this examination, follicle size is examined and categorized into groups of small, medium, and antral follicles. Shifts in the number and size distribution of follicles are correlated with changes in female fertility. In addition to their use as triggers for doing reproduction studies, certain of these measures of reproductive status are more sensitive to chemical-induced injury than fertility. A large decrease in sperm count, for example, can be tolerated by rodents without any effect on fertility, whereas human fertility is affected by smaller changes in sperm count. Thus, the absence of an effect on fertility of rodents does not preclude the possibility of an adverse effect of importance to humans. Therefore, the NTP evaluated the relative predictiveness of measures of semen evaluation, folliculogenesis, and female cyclicity for reproductive toxicity.

The predictiveness of these measurements in prechronic toxicity studies was evaluated by making these observations in the adult animals in NTP continuous-breeding reproduction studies where the data on these triggers, as shown in Table 3, could be compared directly to the outcome of continuous-breeding reproduction studies in mice. The procedures here were the same as those used for rats and mice at the end of 13-week toxicity studies conducted by the NTP. These endpoints, as summarized in Table 3, were evaluated on the basis of sensitivity (the number of correctly identified reproductive toxicants per number of reproductive toxicants in crossover mating trials); specificity (the number of correct negative results per number of nonreproductive toxicants as determined by

crossover mating trials); and accuracy (the total number of correct results per number of chemicals tested). These results are from a relatively small number of total studies (10) where there was no effect on male fertility. The two endpoints that were most predictive of the outcome of the fertility studies were epididymis weight and sperm motility. For this set of chemicals, the other parameters were less effective at predicting the outcome of reproduction studies. While intuitively it would seem useful to consider collectively whether any testis or sperm parameter was affected, the sensitivity of such a composite analysis was high (90%), but the specificity was unacceptably low (33%). The relationship between a significant decrease in male body weight and a decrease in male fertility was also examined in these studies. There was no correlation between a significant decrease in male body weight in these studies and the male fertility.

**TABLE 3. PREDICTORS OF IMPAIRED MALE FERTILITY AS ASSESSED BY CROSSOVER MATING TRIALS IN CONTINUOUS BREEDING REPRODUCTION STUDIES**

Endpoints	Sensitivity %	Specificity %	Accuracy %
R. epididymis weight	80	87	84
R. testis weight	80	67	72
Sperm motility	89	73	79
Sperm concentration	70	80	76
Abnormal sperm	67	73	71
Any sperm/testis parameter	90	33	56
Male body weight	50	47	48

Our examination of folliculogenesis has revealed great variability in the number of follicles, by size, in the adult females in our continuous breeding reproduction studies at about 240 days of age, as well as in the F<sub>1</sub> female offspring at about 110 days of age [3]. The results of this examination are summarized in Table 4. There was a correlation for some chemicals between an altered number of follicles of one or more sizes and female fertility, but the impact of the large variability on the sensitivity of this parameter for prediction of impaired fertility in females remains to be determined.

**TABLE 4. FOLLICLE COUNTS IN FEMALES (CD-1 MICE) OF CONTINUOUS BREEDING REPRODUCTION STUDIES.**

Female Age	Follicles/10th Section		
	Small	Growing	Antral
f <sub>0</sub> , ~240 days	236 ± 21	63 ± 21	6 ± 3
f <sub>1</sub> , ~100 days	408 ± 115	107 ± 28	11 ± 5

Observations that can be made on animals of prechronic toxicity studies are thought to be more useful in predicting the outcome of reproductive studies than developmental toxicity studies. However, that may be so only because we have failed to ask the right questions regarding triggers for developmental toxicity. Table 5 shows the major events that occur during development of mammalian embryos that, if perturbed, could account for developmental toxicity, including teratogenicity. Many of these events are not restricted to the developing embryo but, instead, also are occurring in adult animals of the age used in prechronic toxicity studies. Events such as cell-cell interaction, cell differentiation, cell attachment and recognition, mitosis, and other events that are required to maintain homeostasis are occurring in adult animals as well as in embryos. Tissues such as bone marrow and the epithelium of the intestinal tract would potentially be prime tissues to examine the effect of chemical exposure on these basic cellular phenomena. Thus, with a little more creativity, perhaps animals from prechronic toxicity studies could be providing information regarding the potential of chemicals to cause developmental toxicity in addition to the potential to cause reproductive toxicity.

**TABLE 5. EVENTS DURING EMBRYONAL DEVELOPMENT THAT, IF PERTURBED, SHOULD ACCOUNT FOR DEVELOPMENT TOXICITY**

Cell-cell interaction	Cell attachment
Induction/response	Organ field formation
Differentiation	Programmed cell death
Directed cell movement	Rate of mitosis
Pattern formation	Homeostasis
Cell recognition	Other, known or unknown

The conventional triggers for the concern over effects on the developing embryo and fetus come from prescreens such as studies in hydra, whole embryo cultures, limb bud cultures, micro-mass assays, drosophila, cell culture systems, or other assays; short-term *in vivo* studies such as the one developed by Chernoff and Kavlock [4], and more recently reviewed by Hardin [5], are predictive of the outcome of standard developmental toxicity studies. Probably the most predictive screen of the outcome of the teratology or developmental toxicity studies is the pilot study or the range-finding study which is typically conducted to select dose levels for the traditional teratology study. These pilot studies have become more extensive in the same sense that two-year carcinogenicity studies have become more extensive and costly. Instead of being conducted to simply select dose levels for the definitive developmental toxicity study, these pilot studies are not routinely conducted using multiple dose levels and a modest number of animals per dose level. Examinations include fetal body weight, the number of resorptions, and an external examination; as such, these pilot studies are very highly predictive of the outcome of the definitive study. The question exists here, as for carcinogenicity, whether the final study that is typically conducted for the developmental toxicity

evaluation is in fact a screen or a definitive study. Our inability to identify the mechanism of action of most developmental toxins has discouraged the conduct of studies beyond screens to better understand the development of adverse effects in the embryo and fetus.

To summarize, where do we stand today relative to the three endpoints of toxicity given most attention in this paper – carcinogenesis, reproduction, and development? In the area of carcinogenesis, we need to look more closely at what we expect from the use of the two-year carcinogenicity study as a screen as opposed to using this study to evaluate, in a more definitive manner, the biology of our rodent models and to better understand the pathogenesis of carcinogenic effects in rodents. The area of reproductive toxicology is on the right track by extending beyond measurements of fertility in rodents as predictors of adverse effects in humans. Evaluation of endpoints such as sperm motility, testicular spermatid head count, and testis or epididymis weight are important because they are more sensitive measurements than fertility, and some of these measurements can be made directly in a noninvasive manner in humans. In the area of developmental toxicology, the signals are less clear on where we should be going in the future. Screens that are specific enough to provide information relative to the mode of action of developmental toxicants will identify only those developmental toxicants that work by that mechanism and will miss agents working by other mechanisms. Screens that are sufficiently complex to evaluate several of these mechanisms at once, such as a whole embryo system, will not provide much information regarding the mode of action of developmental toxins. Regarding other potential triggers, we should examine more closely the possibility of making observations on animals in prechronic toxicity studies where the same events can be examined in certain tissues of adults that are the critical events in the developing embryo, and could serve as a screen for predicting developmental toxicity.

#### REFERENCES

- 1 Morrissey, R.E., Schwetz, B.A., Lamb, J.C., IV, Ross, M.D., Teague, J.L., and Morris, R.W. (1988) Evaluation of rodent sperm, vaginal cytology, and reproductive organ weight data from National Toxicology Program 13-week studies. *Fundam. Appl. Toxicol.* 11, 343-358.
- 2 Morrissey, R.E., Lamb, J.C., IV, Schwetz, B.A., Teague, J.L., and Morris, R.W. (1988) Association of sperm, vaginal cytology, and reproductive organ weight data with results of continuous-breeding reproduction studies in Swiss (CD-1) mice. *Fundam. Appl. Toxicol.* 11, 359-371.
- 3 Heindel, J.J., Thomford, P.J. and Mattison, D.R. (In Press) Histological assessment of ovarian toxicity. In *Proceedings of the 7th Ovarian Workshop, Paracrine Communications in the Ovary, Serono Symposia Series*, Plenum Press, New York.
- 4 Chernoff, N. and Kavlock, R.J. (1982) An *in vivo* cytology screen utilizing pregnant mice. *J. Toxicol. Environ. Health* 10, 541-550.
- 5 Hardin, B.D., Becker, R.A., Kavlock, R.J., Seidenberg, J.M. and Chernoff, N. (1987) Overview and summary: Workshop on the Chernoff/Kavlock preliminary developmental toxicity test. *Terat. Carcin. Mutagen.* 7, 119-127.



## SESSION I

### PANEL DISCUSSION

**Dr James Trosko (Michigan State):** Dr Brusick, you have succinctly outlined the nature of this new system. It is very impressive. I want to ask you, however, has this committee dealt with the basic assumption on which this whole edifice is based? Namely, the short-term as well as the *in vivo* genotoxic tests are assumed to tell you that the chemical is genotoxic if you get a positive result in the assay. My point is we know every one of those assays, whether it's a molecular assay or genotoxicity assay, the Ranraff test, UDS assay, sister chromatid, HGPRT, you just go on and on. All of those assays have well-known artifacts that can lead to false positives. What is done in the generation of the quantitative number that you get out of this system to consider those uncertainties?

**Brusick:** The approach that we have taken is that, number one, we do not want to start with the assumption that we know what is a false positive or a false negative. We may think we know, but in all cases we don't know. So, first of all, let's not bias ourself by saying we know that this test gives a lot of false positives. Let the test tell us when it gives us a lot of false positives relative to the consensus. We find that out and, in fact, we are finding it out very quickly that some tests do tend to give you non-consensus answers. Now false positive, I think, in the sense you are talking about, might be for carcinogenicity. We are looking at a genetic hazard. Whether it be somatic cell genetic hazard or germ cell hazard. We are using the consensus for our purposes, now, to define the proper response. And therefore, we are looking at tests that deviate from the consensus or the average consensus. We have looked at many, many different ways of matching each test, or class of test, against the consensus for a broad range of chemicals. So we are getting a feel for those that do not fit the pattern. Also, if you look at enough tests, and unless they are all giving false positive results or false negative results, the true results should dilute the false results and so, we are hoping that by using a weight of evidence that the false responses (assuming that we do not try to judge which ones they are) will be diluted out so that the consensus score will be approaching the right answer. So those are a couple of ways that we are approaching it and it is difficult, but there is no way to get at an absolute. We cannot go into every single test and say "I know this is a false positive." We started with that with things like sodium chloride. We thought sodium chloride was giving us false positives all over the place. It might be, but I am not convinced. I think those are true positives. They are certainly genotoxic results and they probably have some bearing on *in vivo* effect with sodium chloride.

**Dr Ray Yang (NIEHS):** Just one point of clarification. When you say the score represents genetic activity, are you referring to mutagenicity, or is this some sort of new term?

**Brusick:** Genetic activity. We do not want to talk about genotoxicity because to determine genotoxicity all you need is a positive Ames test and you know the material is genotoxic. You can do DNA binding studies, and you know it is genotoxic. I want something to tell me about genetic hazard. By genetic hazard, I am referring to the risk to somatic cells or germ cells of genetic damage that has diseased toxicological complications. So I am concerned about genetic risks (genetic hazard). I do not know if that answers your question or not. Not genotoxic, not germ cell heritable mutation *per se*, because I want to make it broader than that. So, I am saying that if we can use the word "cancer" hazard, because there are a lot of different kinds of cancer and a lot of different mechanisms, I want to use "genetic."

**Dr Harihara Mehendale (University of Michigan State Medical Center):** I have one comment pertaining to benzene. I wonder if the reason for negative results in *in vitro* tests might be because of the solubility problems you encounter in *in vitro* tests, and I do not know whether you have considered that problem in weighing out the *in vitro* tests, versus the *in vivo*.

**Brusick:** Yes, we can begin to look at whether or not certain types of tests, certain types of chemical classes, show us this pattern. It may have to do with solubility, it may have to do with inappropriate activation *in vitro* relative to the whole animal, it may have to do with a certain target cell population. There are a lot of reasons, but we can now start putting into categories all of the chemicals that show virtually no *in vitro* effect and a very strong *in vivo* effect. And we also have chemicals that are just the opposite. Cadmium is all positive *in vitro*; dichloromethane, nothing *in vivo*. How do we interpret those results, and should we give a different kind of weight for *in vitro* and *in vivo*? We may have to do it by class; we can do it in a general way. Those are the things we have not learned about the system. We have not asked those questions yet.

**Mehendale:** Presently you are not counting a certain number of *in vivo* tests and the same number of *in vitro* tests. You are taking whatever tests are available and grouping them, and I noticed many fewer *in vivo* tests for benzene. What is the reason?

**Brusick:** That reflects the data base. If we said we had to have 10 of each, we would have about 10 chemicals in our whole set. The only thing we did was to say that there must be at least three *in vitro* classes and at least two *in vivo* classes or we do not feel the system should be used. So those are the requirements. Any less data than that, and the chemical has to be evaluated differently.

**Dr Ugis Bickis (Queens University):** A question for Lt Col Clewell. Your bioassay work on dioxin, was that done specifically on the 2, 3, 7, 8, isomer or was it a mix?

**Clewell:** We did not do any data collection at all at the AAMRL. This was modeling that was done on the basis of data collected by others. However, the modeling was based on data from work with 2, 3, 7, 8.

**Captain Douglas Knight (Medical Corps, US Navy):** Dr. DePass, have any of these alternative testing methods been applied to behavioral responses to potentially toxic agents or toxic agents?

**DePass:** Do you mean bringing these animals through a form of behavioral toxicity battery?

**Knight:** Yes, as an endpoint rather than death.

**DePass:** Not to my knowledge.

**Mehendale:** Question for Mr. Enslein. With the SAR activity studies, have you looked at how you could make jumps across species for predicting what organs specifically you might have in toxicities? I am thinking about cancer as well as beyond cancer, carcinogenic effects.

**Enslein:** Did you say specifically organ-specific carcinogen effects?

**Mehendale:** I am asking two questions. One, across species from mice to men. The other, organs.

**Enslein:** Yes, I think I mentioned that we have done some interspecies work. The limitations that exist are having data in both species on a sufficient number of compounds. It has obviously been possible in rodents, in some aquatic species, rabbits of course, too, but as far as human data are concerned, the scarcity is too great, except perhaps for skin sensitization, dermal sensitization. Insofar as organ-specific models are concerned, we have attempted to build a liver carcinogenesis model and have been totally unsuccessful. That is, comparing liver carcinogenicity against all other sites, we were totally unsuccessful so far. We only had about 80 compounds to do it with and we now have more like 250, so we are going to try again soon. So far, I do not hold much hope. We have a grant application pending for investigating ordinary hepatotoxic toxicity and that, perhaps, has a greater chance. But not carcinogenesis, but any kind of hepatotoxic effects.

**Dr Walter Switzer (Southwest Research Institute):** I have a question for Dr. DePass. I agree that there is a place for approximate lethal dose calculations in place of classical LD<sub>50</sub>, but the question is, in the approach you use if you calculate an ADL for the female rats, and then you test a group of males at the ADL level to determine if there is a significant difference, how do you go about doing that because the estimate for the ADL for the females could encompass 0 to 100% effects.

**DePass:** Let me see if I understand your question. Were you referring to that last slide where I called it an economical LD<sub>50</sub> protocol?

**Switzer:** Yes.

**DePass:** Well I wasn't really implying that that was an ADL; basically, it was just a simplified LD<sub>50</sub> protocol. But using that simple protocol with females only, you could have made an estimate of the LD<sub>50</sub> for females, and all I suggested was that you would give that dose to males and see if you obtain roughly the same results. That is, if you dose five animals, do you get two deaths, three deaths, four deaths as opposed to zero toxicity, or 100% death for example, which might indicate that you have a true sex difference, in which case you should go back and test males.

**Switzer:** Well, we found that with moving averages, which I think is the best of the lot, that even if you would test the males you would come up with 100% response and there would not be a significant difference because, what is your basis of comparison? Even if you got a 100% effect, it would not indicate that it was significantly more toxic in males.

**DePass:** Your question is really addressing the issue of what is a significant difference, a significant sex difference?

**Switzer:** Yes.

**DePass:** That is really very hard to define, you cannot really do it if you dose just one dose level. It is simply an attempt. The question I propose is not, is there a significant difference, so much as is the toxicity roughly equivalent as much as you can determine with a simple test with a small number of animals? You are really not answering the question of is there a statistically significant difference between the toxicity in the two sexes.

**Enslein:** I would like to make a comment on that. Acute toxicity test LD<sub>50</sub> is really a logarithmic parameter. To look at it in a linear way, that is on a linear scale, I think is biologically meaningless. But whether a compound has an LD<sub>50</sub> of 1500 or 1650 mg/kg is totally meaningless because the measurement alone will readily introduce a factor of two, even within one laboratory. Across laboratories a factor of 10 is not unusual. So to look at this parameter linear scale just has no meaning. Yes, you can produce a *t*-test that shows a statistical difference but biologically it means nothing. For the same reason I think it is important to consider structure activity models as an alternative. If for nothing else, for dose, because with structure-activity models you can get within the factor of two for at least 50% of the compounds, even on the relatively coarse models that exist now and a factor of five for around 80 to 85% of them. This is as good as you would need most of the time, even for criteria like DOT's (Department of Transportation) which is simply one level.

**Dr Clay Frederick (Rohm and Haas Company):** This is a question or comment directed to Dr. Brusick's area. I am impressed with the general procedures presented for handling a variety of flawed or partially flawed assays that we deal with in toxicology to try to draw a weight of evidence approach to handling the toxicity of a chemical. I think it is a reasonable way of handling a variety of data that may conflict at various levels of uncertainty, but what concerns me is looking back to when essentially

Kenny Crump provided a similar procedure as an interim approach to handle risk assessment in the carcinogenicity area, and I think now as we move on to hopefully better tools, these interim ways of handling inadequate information or flawed information tend to assume almost a religious dogma in some people's mind. Then as science moves on to what I would hope to be better techniques, it is viewed with suspicion for trying to change the dogma. I guess that what I am thinking is, with regard to short-term test, if someone like Jim Trosko comes along with the ultimate short-term test that hits 100% of the time, and if we were to drop it in some mindless way into this sort of weight-of-evidence-type program, it would essentially be diluted out by all these other imperfect assays.

**Brusick:** Two comments. The first is I do not think that this will be a significant problem with the proposed method because it is designed to look retrospectively. It is not designed for prospective, meaning that we are not planning to use it to look at a new set of data because the testing strategies have changed. We do not do 15 or 20 tests that often anymore. It really has its greatest utility on data sets that already exist and require some decision making. The second comment is that if you are talking about a short-term test for carcinogenicity that is perfect, I can buy that, there may be one that is perfect. It should be recognized that if anyone had that, they would not want to drop it into a scheme like this. You do not need to drop it into a scheme if it gives you a perfect correlation. But on the other hand, if we are talking about genetic activity, I think it is going to be very difficult to know that you have a perfect test. We do not have any criteria to judge a single test as being essentially a perfect test for genetic activity. So, until that comes up I would not be too worried about that.

**Schwetz:** With the same system, Dave, sometimes when you look at the profile of the results of the various tests, some of the outliers are more meaningful than what establishes the mean. As you come down to an agent score, how do you retain the importance of those outliers?

**Brusick:** Let me start back. Some of the outliers will disappear because we have now added one or two factors that will take away testness; some of the outliers are attributed to the fact that certain tests handle chemicals on the average more efficiently than other tests. As an example, the cell transformation assays tend to be, as a group, more sensitive on the average chemical. The reason is that they handle chemicals more efficiently and they would then tend to make a compound appear to be more positive, not because the chemical itself is more bioreactive, but because if you test it in cell transformation assays you are going to get more high scores. We have recognized that and we have taken all of the test systems and we have normalized all tests hopefully for testness. We have removed testness and we have gotten the sense of the average efficiency with which all tests handle chemicals. That reduces outliers. The other thing that we want to find out is whether we are trying to define tests that are redundant and, if that is the case, then we want to eliminate outliers, and whether we are looking for complementation, and therefore we would be looking at outliers as a way of securing better information rather than eliminating outliers. So I think that that is a very good

point; we have not yet decided how to handle outlier tests. They may either be tests that you want to get rid of or there may be tests that you really want to keep because they tell you something that all the rest of the tests do not tell you because they are essentially redundant. It is a good question and I do not have any better answer.

**Clewell:** While we have got you on the spot, I would like to ask the question I did not have time to ask before which was, I really like the system you have because it kind of definitizes the question and lets it be explicit. What I am wondering is, now that you are looking at comparing your *in vitro* test scores with the two-year test, on the one hand, you have *in vitro* batteries designed to look for genetic effects and on the other hand you have the two-year bioassay that just looks for carcinogenesis. How are you handling the question of the mechanism by which the chemical acts, because it seems like so many are considered to act by promotion or cytotoxicity as opposed to direct genetic interaction?

**Brusick:** I would have to say that starting off we do not expect to find a good correlation; that is number one. When we put the two side-by-side and we have sufficient numbers of chemicals where we can make a direct comparison between the two-year studies from the NTP and the genetic activity scores, I would say that we are not highly confident that we are going to get a one-to-one correlation, that they are not going to rank the same ranking for that reason primarily. We do have the option of looking at subsets; we can begin to then have a dual-track system that we already have built into the thing. If we want to look at carcinogenicity, we can take the test systems, and through other information, preweight certain tests that tend to give us a better correlation (give us higher weights when we are trying to make a carcinogenetic prediction), down weight the test that do not, and the other option is that there are being developed short-term tests and *in vivo* tests that are prescreens for nongenetic carcinogens that we intend to put into this system and then add it as a component of the final assay score. So that may get us where we want to go.

**Knight:** Submariners are a group of workers who live in contaminated atmospheres for 60 to 90 days and then repeat this sort of experience for their career. They are one population of humans, therefore, that are chronically exposed to potentially toxic materials. We have not found any effect of these atmospheres on submariners that you could label a toxic effect, or even a dangerous effect; we are quite satisfied with their health. Nonetheless, as scientists, we are still looking for possible adverse effects. I wonder if the panel members wish to address my comment as this morning's session is entitled "Improvements in Toxicological Testing." Are there new ways of screening confined humans for toxic effects when exposed to trace contaminants?

**Schwetz:** As we consider how to relate animal data to humans, we have been talking now through the last few years about the ultimate goal of finding biomarkers of disease. We recognize that we do

not have many of those, and the ones that we thought might have been useful end up being not as useful as we had hoped, not very specific, so you back off and you hope that maybe we can find some biomarkers of exposure. And I would hope that eventually either of these would become helpful to these kinds of individuals as well as everybody else who is exposed to materials, whether it is occupationally, or through drug use, or whatever it might be. But being more realistic in what can be done today, I would like to just comment on one aspect of what I would assume is also part of the submariner's life: not only is he confined there for a couple of months, but after a short reprieve he is probably confined again to the same kind of environment. One of the things that a number of us are concerned about that we do not evaluate to any great extent, is the effect of intermittent exposures. We do intermittent exposures when we do daily, but I mean intermittent in that we expose animals for two months, take them to a certain level of toxicity, and remove the exposure and allow them to return to normal and then expose them again to find out if the same things happen. Does it happen more intensely, does it happen more quickly, or do other things happen? And while there is a very small amount of information in this regard, we do not have enough of a data base to say really what the likelihood is for the response to the second, third, and fourth exposures, how that would compare to what you would expect from the first one. Now it would seem that with cell culture systems or with other systems we might also be able to address this issue, but maybe some of the others would comment on that.

**Dr Melvin Andersen (AAMRL):** Never let it be said that I passed up an opportunity to pitch modeling. One of the obvious things that can be done now that could not be done just a few years back is to do physiologically based modeling of the differences that the exposure scenario makes. Clearly, computer modeling can be useful in trying to see whether the particular environment of the submariner might lead a particular chemical to be toxic in that scenario more so than in the typical workday environment.

**Dr Fred Miller (EPA):** My question is directed to Dr Schwetz. Given the concern on chronic exposure and given the extent of cardiopulmonary disease in this country in association with long-term exposure, I was interested that you did not discuss triggers in this regard and, therefore, my question is this: Is it your opinion that there are no triggers for the pulmonary toxicity area or is it simply that this particular area has not been addressed thus far?

**Schwetz:** It is probably a combination of the two. In reviewing the agreement between what types of cancers, for instance, or other chronic diseases we see in humans and what we have been able to predict from animal studies, we recognize that the animal studies are limited in their ability to predict the adverse effects of alcoholic beverages as well as cigarette smoking, where we have these types of complications. The models do exist, to some extent, to look for these chronic effects from various types of chemicals but they have been used on a very limited basis, and as most of the two-year

studies or 90-day studies are done, we do not incorporate specific measurements of cardiovascular function, partly because of having done these mostly in rats and mice. It would be a little easier to assess these in dogs and primates, but they do not tend to end up being studied with the same kind of confidence we have in the rodent studies.

**Trosko:** Dr Schwetz, I want to concur with your general take-home lesson that we really do have to reassess the kinds of bioassays one uses for any of those toxicological endpoints that you reviewed as well as some of the short-term tests. In particular, I guess, I want to reinforce your emphasis on looking for common underlying mechanisms, and obviously for those few of you who know of my work, it is very clear in most of those endpoints you have identified, whether it is teratogenesis, reproductive dysfunction, neurotox, immunotox, cancer, all of those necessitate in a higher organism one basic biological process, namely intercellular communication. Not only can there be developed short-term screens for chemicals that modulate this very important process, but I think there will be people here who will talk about developing schemes *in vivo*, and all I am saying is that here is a common mechanism cutting across all of these toxic endpoints that heretofore most people have paid no attention to.

**Schwetz:** Thank you for your comment. Hopefully there will be some test system, some mechanistic endpoint, that if we learn enough about it as you are certainly moving the front forward, as we understand one of those basic mechanisms better, it certainly will be more broadly useful than some other more specific types of mechanisms that may be specific to one type of toxicity and not another. We had an interesting meeting recently when we considered where we should be going in this area of *in vitro* teratology, and after a day of having eight or ten of us together who had varying degrees of experience from the standpoint of developing *in vitro* test systems and their applications to teratology as a question, it was obvious that because of the complexity of the developing embryo as opposed to the complexity or the simplicity (we don't know which it is) in carcinogenesis, we thought that interaction with DNA might be sufficient to explain carcinogenesis, but it is obviously more complicated than that. Nonetheless, if you measure changes in DNA, it is a fairly good prediction of what is going to happen at some stage along the way if you have all the rest of the circumstances right in carcinogenesis. But you can pick any one of those mechanisms or endpoints in the development of the embryo, and which ones of those are sufficient to disrupt development that it would result in some permanent damage, we do not know. If you pick one that is so specific that you look only at, for instance, cell attachment, or cell growth, or maybe cell-cell communication, you end up understanding some mechanistically useful information, but that may not be sufficient to cause a developmental effect. By the time you get to the whole embryo where you get information that is useful from the standpoint of predicting for another whole embryo, you can no longer address those



mechanistic-type questions. Again, the likelihood that any one test system is going to predict development is pretty small.

**Mehendale:** Some years ago we tried to determine what fraction of compounds that are carcinogens are also teratogens and also Ames mutagens and the proportion is surprisingly small. At least insofar as rodent two-year assays are concerned on the one hand. I do not know if that is indicative or counterindicative of a single "test" being or a common underlying mechanism. We are about to repeat that experiment with a fairly large number of compounds and I will be curious to see what comes out of it.

**SESSION II**

**TOXICITY AND INTERACTIONS OF MIXTURES**

**Dr Raymond S.H. Yang, Chairman**

## TOXICOLOGY OF CHEMICAL MIXTURES: EXPERIMENTAL APPROACHES, UNDERLYING CONCEPTS, AND SOME RESULTS

Raymond S.H. Yang, H.L. Hong, and Gary A. Boorman

*National Toxicology Program, National Institute of Environmental Health Sciences,  
P.O. Box 12233, Research Triangle Park, NC 27709*

### SUMMARY

The toxicology of chemical mixtures will be the toxicology of the 1990s and beyond. While this branch of toxicology most closely reflects the actual human exposure situation, as yet, there is no standard protocol or consensus methodology for investigating the toxicology of mixtures. Thus, in this emerging science, experimentation is required just to develop a broadly applicable evaluation system. Several examples are discussed to illustrate the different experimental designs and the concepts behind each. These include the health effects studies of Love Canal soil samples, the Lake Ontario Coho salmon, the water samples repurified from secondary sewage in the city of Denver Potable Water Reuse Demonstration Plant, and the National Toxicology Program (NTP) effort on a mixture of 25 frequently detected groundwater contaminants derived from hazardous waste disposal sites. In the last instance, an extensive research program has been ongoing for the last two years at the NTP, encompassing general toxicology, immunotoxicology, developmental and reproductive toxicology, biochemical toxicology, myelotoxicology, genetic toxicology, neurobehavioral toxicology, and hepato- and renal toxicology.

### INTRODUCTION

Chemical mixtures, as the term is applied here, encompass anything from two chemicals in combination (most published toxicological interaction studies) to hundreds of chemicals in combination plus unknown components (hazardous waste disposal site samples, diesel exhaust, tobacco smoke condensate). Because of the unusually wide range of composition of the test samples, it is not surprising that there are really no standard approaches and/or protocols to investigate the health effects of chemical mixtures. In recent years, there have been efforts to distill the collective wisdom from reputable toxicologists to provide guidelines and approaches for the study of the complex mixtures. One notable example is the recent National Research Council publication [1] on testing approaches for *in vivo* toxicological studies of complex mixtures. However, because of the dearth of actual experimental information, this monograph, like several predecessors, is mostly theoretical in character.

In the present paper, four actual examples of experimental approaches with different objectives and techniques are given. The last example, a special initiative on the toxicology of

chemical mixtures of environmental concern at the NTP, is described in detail to illustrate the genesis, underlying principles, and the empirical attempts to reach the approach.

## EXPERIMENTAL APPROACHES TO STUDY CHEMICAL MIXTURES

### *Toxicology Studies of Love Canal Soil Samples*

Love Canal was a chemical and municipal waste dumpsite in Niagara Falls, NY, from the 1920s until 1953, when it was covered with earth [2]. Subsequent residential development, including a school directly bordering the landfill, eventually led to public concern over the potential hazard of chemical waste to human health.

In 1984, Silkworth and coworkers of the New York State Department of Health reported studies with female CD-1 mice designed to assess the toxic effects of exposure to the Love Canal surface soil and its volatile components [2]. The salient points of the experimental design, methods, and results are summarized below.

**Test Samples.** Soil samples (approximately 100 kg) were collected in 1978 from approximately 20 surface sites (to a depth of 30 cm) in the southern canal area. The samples were mixed, double bagged (plastic bags), and sealed at the site. These bagged soil samples were stored in 5-gal steel drums. Over the 2.5-year storage period, the investigators [2] stated the soil retained its moisture, as assessed visually.

**Experimental.** The experimental approach is summarized in Table 1. Exposures of mice to Love Canal soil samples were carried out in polystyrene cages containing about 1 kg soil/cage. The mouse cages were in turn placed in sealed polypropylene chambers with dynamic air flow systems. For the group of mice exposed to volatiles from the soil, the animals were housed on a perforated stainless steel platform above the soil. For the group of mice exposed to the nonvolatiles and volatiles in the soil, the animals were allowed to come into direct contact with the soil (i.e., without the platform). Control mice were housed identically but without soil. In a separate set of experiments, the cages (which are inside the exposure chambers) were covered with polystyrene lids to provide higher concentration of volatiles. The soil was replaced weekly, and the animals were exposed up to 90 days. Histopathologic, hematologic, and serum enzyme studies followed necropsy of all mice. Chamber air and soil samples, both fresh and after the seven-day exposure period, were analyzed for volatile and nonvolatile chemicals by gas chromatography and mass spectrometry.

**Results.** A total of 87 components were detected in the air collected in cages containing soil; 25 of them were identified. Eighteen chlorinated compounds were identified in the soil although the identity of about 95% of the mass remained unknown. The concentrations of chemicals quantified in the air ranged from 0.1  $\mu\text{g}/\text{m}^3$  (trichloroethylene) to 1,065  $\mu\text{g}/\text{m}^3$  (pentachlorobenzene) and those

measured in the soil ranged from 0.2 µg/g (2,5- and 2,6-dichlorotoluene) to 26,848 µg/g (alpha-hexachlorocyclohexane).

**TABLE 1. EXPERIMENTAL APPROACH FOR LOVE CANAL SOIL STUDIES**

Animals	Female CD-1 mice; 10 mice/group
Duration	13 weeks
Routes	Inhalation (continuous); 2 exposure levels Inhalation + contact (continuous for both); 2 exposure levels
Soil	1 kg/cage/week
Endpoints	Clinical signs, mortality, body weight, food consumption, hematology, gross and histopathology

Silkworth et. al. 1984 [2]

There was no mortality throughout the experiments. Mice exposed to elevated concentrations (i.e., cages covered with lids inside the exposure chamber) of volatiles had increased body and relative kidney weights. There were no chemically induced lesions in any animals exposed only to volatile soil contaminants. Mice exposed to the soil for 90 days by direct contact and simultaneously to elevated concentration of volatiles had centrilobular hepatocyte hypertrophy and increased relative liver, spleen, and kidney weights. Liver appeared to be the primary target organ [2].

#### ***Toxicologic Studies of Contaminated Coho Salmon***

The presence of toxic and hazardous substances in the Great Lakes has been a continuing concern for many scientific organizations including the International Joint Commission on Great Lakes Water Quality [3,4]. One of the most pressing problems was the lack of knowledge of the possible toxicologic interactions among these pollutants. To assess the health effects of the Great Lake pollutants, Villeneuve, Chu, and colleagues of the Canadian government carried out two unique toxicologic studies by feeding the Lake Ontario coho salmon and Pacific coho salmon (control) to Sprague-Dawley rats [3,4].

**Test Samples.** Lake Ontario coho salmon were chosen for the studies because (1) fish are thought to represent the main source for transfer of toxic contaminants in the Great Lakes to humans and birds; herring gulls that fed on fish in the Lake exhibited toxicological signs consistent with organochlorine poisoning [3]; (2) coho salmon are large, carnivorous fish that have been shown to accumulate relatively high levels of organochlorine contaminants in Lake Ontario; and (3) Lake Ontario is the most contaminated of the Canadian Great Lakes. Pacific coho salmon were chosen as a control test sample because (1) the levels of monitored contaminants in Pacific salmon were much

lower (a few orders of magnitude) than in Lake Ontario salmon and (2) the use of control salmon provides nutritional equivalency to experimental animals.

To prepare salmon-containing diets, sexually matured coho salmon (test salmon from Lake Ontario, control salmon from the Pacific Ocean at Vancouver) were collected during the fall spawning runs and immediately fileted and frozen. Following freeze-drying, the fish was milled, incorporated into a ground cube diet (Master Fox, Purina Ralston), and pelleted for animal consumption. The levels of freeze-dried fish in the diets were 1.45, 2.9, or 5.8%, which correspond to levels of approximately 5, 10, or 20% on a wet-weight basis [3].

**Experimental.** A 28-day study [3] preceded a six-month subchronic study containing a three-month recovery period [4]. Because the dose levels were the same for both studies, only the six-month study will be discussed here. Sprague-Dawley rats were used in the study at 20 rats/sex/group. The salmon-containing diets (both the Lake Ontario salmon and Pacific salmon) were given at 1.45, 2.9, and 5.8% of salmon (dry weight), and the control rats were given ground Master Fox cubes (Purina-Ralston). After 13 weeks, 10 rats/sex/group were killed, and the remaining animals were fed a fish-free diet for another 13 weeks. Toxic endpoints assessed included clinical signs, body and organ weights, food intake, clinical pathology, biochemical analyses, gross and histopathology, and tissue residue analyses for organochlorine contaminants.

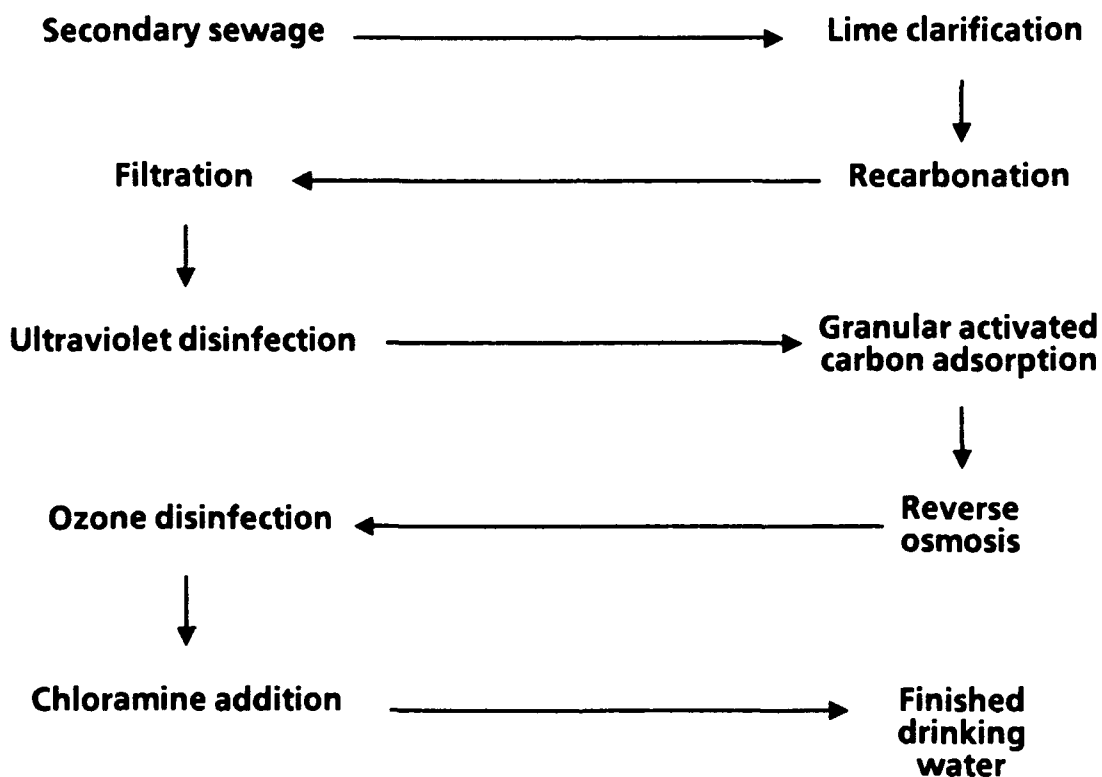
**Results and Findings.** The contaminants showing the highest concentration in Lake Ontario salmon were polychlorinated biphenyls (25.5 ppm, on a dry-weight basis), *p,p'*-dichlorodiphenyldichloroethylene (5.8 ppm), mirex (1.2 ppm), *p,p'*-1,1-dichloro-2,2-bis(*p*-chlorophenyl)ethane (0.7 ppm), photomirex (0.4 ppm), *cis*-chlordane (0.22 ppm), dieldrin (0.27 ppm), *p,p'*-dichlorodiphenyltrichloroethane (0.2 ppm), and *trans*-chlordane (0.11 ppm). All other contaminant levels in Lake Ontario salmon were below 0.1 ppm. The animal toxicity study results indicated that the Lake Ontario salmon-supplemented diet can cause mild biochemical, hematological, and histological changes but most of these were reversible when exposure was terminated [3,4].

#### **Denver Water Department Potable Water Reuse Demonstration Plant Health Effects Studies**

To plan for meeting the anticipated future needs of water in the wake of dwindling water resources, the Denver Water Department, for many years, has researched a plan to convert treated wastewater to potable water. In May 1979, the Denver Water Department and the US Environmental Protection Agency (EPA) entered into a cooperative agreement to build a one million gallon per day Potable Water Reuse Demonstration Plant to test, among other things, the feasibility of directly utilizing recycled, purified wastewater effluent for drinking and other household purposes [5-8].

The demonstration plant construction began in 1981 and was completed in 1984. The plant has been operating since January 1984 and will continue operating through the animal toxicity studies of health effects testing program, which is expected to end in 1990 [8].

The plant draws unchlorinated secondary effluent from the nearby Metropolitan Denver Sewage Disposal District Number One treatment facility. Based on many different trials, a final treatment process train (Figure 1) including lime clarification, recarbonation, filtration, ultraviolet disinfection, granular activated carbon adsorption, reverse osmosis (including air stripping), ozone disinfection, and chloramine addition appeared to be the most desirable one.



**Figure 1. Treatment Process Train for Recycling Wastewater at the City of Denver Potable Water Reuse Demonstration Plant.**

The recycled water quality is excellent and has fewer and lower contaminants than the present Denver drinking water based on extensive analyses of samples from these two water sources. However, Denver Water Department, in an attempt to ensure product water safety, initiated a comprehensive health effects testing program [8]. The general features of this testing program consist of chronic toxicity and carcinogenicity studies and reproductive toxicology studies in Fischer 344 rats and B6C3F1 mice on the 500 x and 150 x concentrates of the current Denver drinking water (control) and the recycled water. The major points of their experimental approach are given below.

**Experimental Approach.** Several different methods of concentration including adsorption on XAD resins, liquid-liquid extraction by continuous processing, and membrane processes (ultrafiltration or reverse osmosis) followed by resin adsorption or solvent extraction were evaluated, and the XAD resin concentration provided the best results [8]. Because the concentration processes do not recover all the volatile contaminants, it was decided that any identified contaminant with a concentration in excess of 1 ppb will be added to the reconstituted drinking water samples (at 150X and 500X the actual analytically determined values) for toxicology studies. The overall approach is summarized in Figure 2 and, at the writing of this manuscript in February 1989, the animal toxicity studies are in progress.

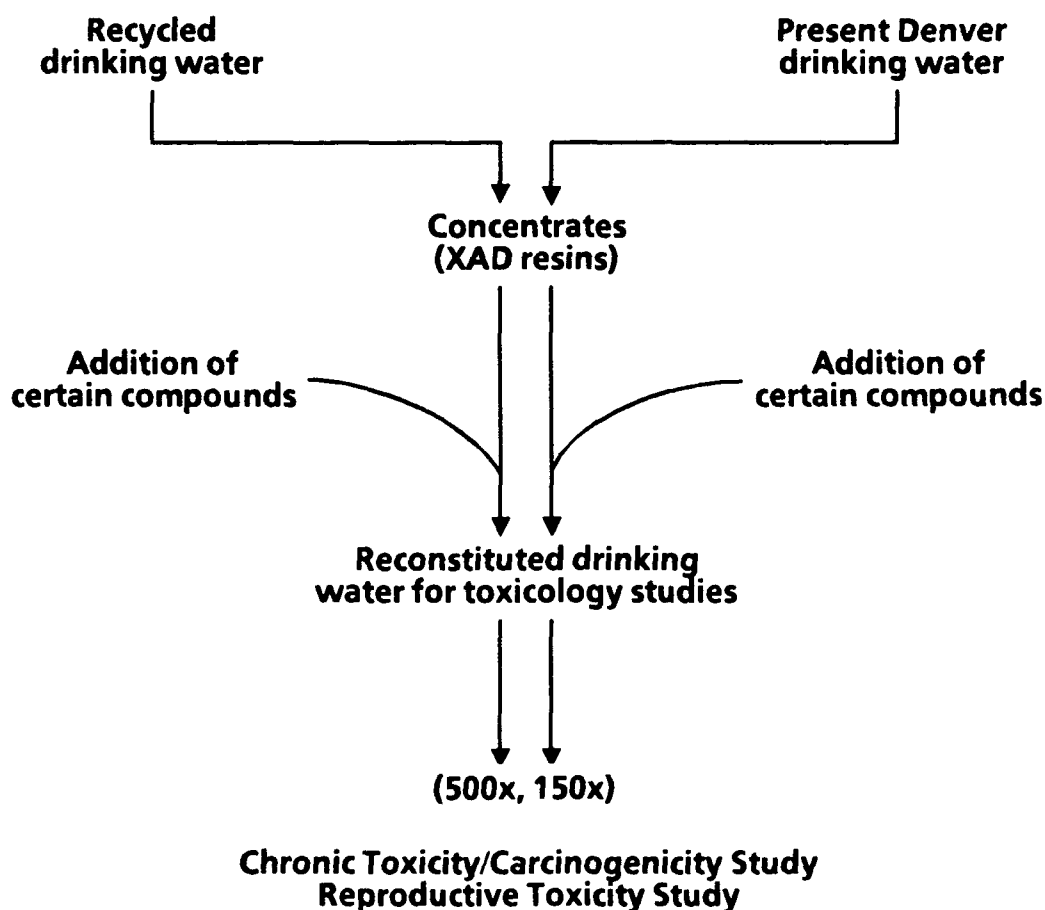


Figure 2. Experimental Approach for the City and County of Denver Health Effects Studies of Recycled Water.

**Toxicology of a Chemical Mixture of 25 Groundwater Contaminants**

Under an interagency agreement with the Agency for Toxic Substances and Disease Registry, the NTP was to study chemicals and chemical mixtures that are found at or near hazardous waste



disposal sites. Because there is no such thing as a representative sample of the more than 25,000 known hazardous waste disposal sites, the NTP took the approach of studying the health effects of a chemically defined mixture of frequently detected groundwater contaminants near hazardous waste disposal sites. The rationale for the decision was based on several facts: (1) a representative sample for the possible mixtures present in the more than 25,000 hazardous waste disposal sites cannot be obtained; (2) groundwater represents a precious national resource and the contamination of groundwater has become an increasingly alarming problem; (3) the leaching of chemicals into the groundwater from hazardous waste disposal sites provides a "commonality" to all hazardous waste disposal sites, thus formulating a basis for a more representative sample; and (4) the study of health effects from a chemically defined mixture of the most prevalent groundwater contaminants near hazardous waste disposal sites would complement the efforts by other laboratories which concentrate their efforts on either binary chemical mixtures or complex chemical mixtures of uncertain identities.

The background information on the genesis of a toxicology program on chemical mixtures simulating groundwater contaminants at the NTP in the National Institute of Environmental Health Sciences (NIEHS), the rationale for investigating a chemically defined mixture containing 25 organic and inorganic compounds, the guidelines used to select the chemicals, the theoretical exercises leading to the setting of target-dose levels, and the experimental approach and design were reported in detail in an earlier publication [9]. Some of the initial results on the developmental chemistry work, suitability of such a mixture for toxicological studies, immunotoxicity, male reproductive toxicology studies, and other aspects of health effects on this chemical mixture have been published elsewhere [10-16].

The formulation, composition, and analysis of a technically achievable stock solution in deionized water of a 25-chemical mixture were given in detail by Yang et al. [14]. With some exceptions, the concentrations of individual components in this stock are approximately at their respective 90% saturation levels in this particular matrix. This stock solution is too concentrated to be used for animal experimental work because of palatability (i.e., water consumption reduced by 90%) and mortality problems [16]. Therefore, in subsequent animal studies, particularly those studies with experimental periods of three months or longer, a 10% solution of the stock was used as the highest dose, as shown in Table 2; the other doses were usually 5% and 1% of the stock or lower [10-13,15]. The concentrations of the 25 component chemicals are comparable to the respective EPA average survey values in groundwater near hazardous waste disposal sites (Table 2), as the ratios in Table 2 illustrate, with the exception of three chemicals (all metals) that are greater than tenfold higher than the EPA survey values; in fact, eight chemicals were below the average EPA survey values. Two actual examples of pollution, trichloroethylene (TCE) in the potable water wells of Silicon Valley, CA, and

**TABLE 2. COMPARISON OF CONCENTRATIONS OF THE COMPONENTS OF THE 25-CHEMICAL MIXTURE<sup>a</sup> DOSING SOLUTION WITH EPA SURVEY RESULTS<sup>b</sup>**

Chemical	A	B	Ratio B/A
	EPA Survey Mean Results (ppm)	High Dose Concentrations (ppm)	
Acetone	6.9	53	7.7
Arochlor 1260	0.21	0.01	0.05
Arsenic	30.6	9	0.29
Benzene	5.0	12.5	2.5
Cadmium	0.85	51	60
Carbon tetrachloride	0.54	0.4	0.74
Chlorobenzene	0.1	0.1	1
Chloroform	1.46	7	4.79
Chromium	0.69	36	52.2
DEHP	0.13	0.015	0.12
1,1-Dichloroethane	0.31	1.4	4.52
1,2-Dichloroethane	6.33	40	6.32
1,1-Dichloroethylene	0.24	0.5	2.08
1,2- <i>trans</i> -Dichloroethylene	0.73	2.5	3.42
Ethylbenzene	0.65	0.3	0.46
Lead	37.0	70	1.89
Mercury	0.34	0.5	1.47
Methylene chloride	11.2	37.5	3.35
Nickel	0.5	6.8	13.6
Phenol	34.0	29	0.85
Tetrachloroethylene	9.68	3.4	0.35
Toluene	5.18	7	1.35
1,1,1-Trichloroethane	1.25	2	1.6
Trichloroethylene	3.82	6.5	1.7
Xylenes	4.07	1.6	0.39

<sup>a</sup> 3 chemicals > 10 × the average EPA survey concentration

14 chemicals were 1 × to 10 × the average EPA survey concentration.

8 chemicals were < 1 × the average EPA survey concentration.

<sup>b</sup> From Yang et. al. [15]; EPA survey was conducted by Lockheed Engineering and Management Services Company, Inc., July 1985.

carbon tetrachloride (CCl<sub>4</sub>) in Hardeman County, TN, should provide further comparison to the NTP chemical mixture. In the former case, the TCE concentration in the worst polluted well in Silicon Valley was 2.8 ppm [17] and, in the latter case, CCl<sub>4</sub> concentrations in the contaminated wells in Hardeman county ranged from 0.061 to 18.7 ppm with a median of 1.5 ppm [18]. In comparison, the NTP chemical mixture tested contained TCE concentrations at approximately 0.65, 3.25, and 6.5 ppm and CCl<sub>4</sub> concentrations at approximately 0.04, 0.2, and 0.4 ppm. Therefore, the dose levels studied in the NTP toxicology work were environmentally realistic concentrations in that they were comparable to the heavily polluted groundwater near hazardous waste disposal sites. It should be noted that the levels of contaminants in the drinking water of the overwhelming majority of the general population in the United States are probably several orders of magnitude lower than those presented in Table 2.

As of February 1989, over 30 studies of varying size and duration have been completed or were ongoing on this mixture at the NTP or at other agencies and laboratories under collaborative efforts with the NTP. The areas covered included general toxicology, immunotoxicology, reproductive and developmental toxicology, biochemical toxicology, neurobehavioral toxicology, myelotoxicology, genetic toxicology, hepatotoxicity, and nephrotoxicity. In the section below, some results from immunotoxicology [11], hepatotoxicity [13,15], and myelotoxicity [12] will be discussed.

When this 25-chemical mixture of groundwater contaminants was given to female B6C3F<sub>1</sub> mice for 14 days or three months in drinking water, suppression of immune function was seen in three of the parameters examined at 5 or 10% (Table 2) of the mixture stock or higher [11,15]; the results are summarized in Table 3. First, the suppression of bone marrow stem cell proliferation, as expressed by the number of colonies formed of the granulocyte-macrophage (GM) progenitor cells, is presented. Note the lack of response in the paired-water control group in the 14-day study; this finding suggests that the immunotoxic responses seen had little, if anything, to do with the reduction of water consumption in the treated groups. A clear dose-response relationship was demonstrated in the 90-day study results on the suppression of bone marrow stem cell proliferation. The second immunological endpoint affected is the suppression of antigen (sheep red blood cell)-induced antibody-forming cells (Table 3); similar results, as discussed above, for the stem cell suppression are also evident for this endpoint. Three host resistance assays following challenge with infectious agents (*Lysteria monocytogens*, PYB6 syngenic tumor cells, or *Plasmodium yoelii*) were investigated [11]. Altered resistance, as expressed by percent parasitemia, occurred in the group challenged with *Plasmodium* (Table 3). These results collectively suggest that long-term exposure to heavily contaminated groundwater such as the mixture in these NTP studies may represent a risk to the immune system [11].

In a collaborative effort between the EPA and the NTP, we examined the effects of pretreatment of the 25-chemical mixture of groundwater contaminants for 14 days to the

**TABLE 3. IMMUNE FUNCTIONS IN B6C3F<sub>1</sub> MICE AFFECTED BY EXPOSURE TO A CHEMICAL MIXTURE OF GROUNDWATER CONTAMINANTS**

Exposure Level (% Stock)	CFU-GM/ 10 <sup>5</sup> cells <sup>a</sup>	PFC/Spleen (X 10 <sup>3</sup> ) <sup>b</sup>	<i>P. yoelii</i> % parasitemia <sup>c</sup>
<b>14-day study</b>			
0	59.8 ± 6.0	172 ± 16	14.2 ± 1.2
0.2	57.2 ± 1.3	231 ± 16	9.2 ± 1.0
2.0	55.4 ± 3.2	157 ± 24	19.8 ± 2.9
20.0	37.8 ± 0.4**	96 ± 16**	22.1 ± 2.9*
Paired water	50.5 ± 1.3	172 ± 17	N.D. <sup>d</sup>
<b>3-month study</b>			
0	55.3 ± 2.1	189 ± 49	10.1 ± 1.5
1.0	52.6 ± 2.9	120 ± 19	9.4 ± 2.9
5.0	43.5 ± 4.6*	144 ± 21	12.7 ± 1.9
10.0	29.6 ± 1.7**	93 ± 15	20.8 ± 2.9*

<sup>a</sup> The CFU-GM, granulocyte-macrophage colonies were assayed by incubating femoral bone marrow cells in the presence of mouse lung conditioned medium as a colony-stimulating factor at 37°C in 5% CO<sub>2</sub> for 7 days. Colonies of >50 cells were enumerated using a stereomicroscope. Values given represent mean ± SEM of CFU-GM per 10<sup>5</sup> cells for at least five mice per group.

<sup>b</sup> The antibody response to sheep erythrocytes was determined by enumerating plaque-forming cells (PFC) in splenic lymphocytes four days after primary immunization. Values given represent mean ± SEM of PFC per spleen for at least five mice per group.

<sup>c</sup> Infection with the malarial parasite, *P. yoelii*, was determined by quantitating the percent parasitemia on days 10, 12, and 14 following injection of 10<sup>6</sup> parasitized erythrocytes. Only peak day, Day 12, of infection is shown. Values given represent mean ± SEM of eight mice per group.

<sup>d</sup> N.D. = not done.

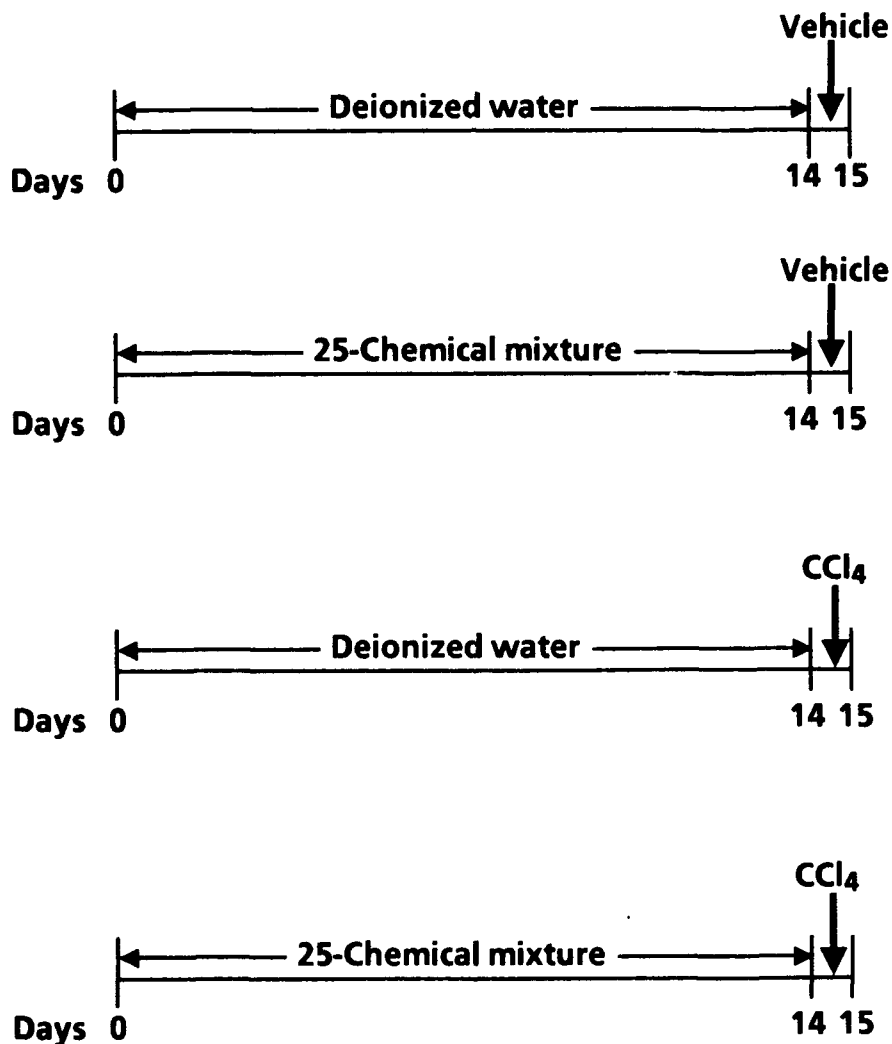
\*\* Significantly different from control at p<0.01.

\* Significantly different from control at p<0.05.

From Germolec et. al. [11]; Yang et al. [15].

hepatotoxicity of CCl<sub>4</sub> in male Fischer 344 rats [13, 15]. Preliminary results from a pilot study (see Figure 3 for experimental design) are summarized in Table 4. The deionized water control group and the drinking water chemical mixture alone group, at both low (1% mixture stock) and high (10% mixture stock) dose levels, showed no histopathological changes in the liver. While the CCl<sub>4</sub> alone group showed a typical mild centrilobular vacuolar degeneration at the dose level applied (0.075 mL/kg), the pretreatment of a low dose level mixture did not alter the hepatotoxicity. However, the high mixture/CCl<sub>4</sub> group showed, in addition to the mild centrilobular vacuolar degeneration,

minimal centrilobular hepatocellular necrosis as well. The necrotic changes in the liver in the high mixture/ $\text{CCl}_4$  group also coincided with the elevation of serum aspartate aminotransferase (177% of controls) and alanine aminotransferase (273% of controls). These findings suggest an enhancement of hepatotoxicity of  $\text{CCl}_4$  by the pretreatment of the chemical mixture of 25 groundwater contaminants. A more detailed study is currently underway.



**Figure 3.** Experimental Design for the EPA/NTP Hepatotoxicity Study.

In the myelotoxicity study, the possible toxicological interaction of the 25-chemical mixture of groundwater contaminants and whole-body irradiation (WBI) on hematopoiesis was investigated [12]. Exposure of B6C3F<sub>1</sub> mice to the chemical mixture (5% mixture stock) markedly reduced bone

**TABLE 4. ENHANCEMENT OF CARBON TETRACHLORIDE HEPATOTOXICITY IN MALE FISCHER 344 RATS BY PRIOR EXPOSURE TO A MIXTURE OF 25 GROUNDWATER CONTAMINANTS**

Treatment <sup>a</sup> Groups	No. Animal Examined	Clinical Chemistry Parameters		Liver Histopathology (No. Rats with Lesion)		
		AST <sup>b</sup>	ALT <sup>b</sup>	Normal	Vacuolar Degeneration	Cellular Necrosis
Control/control	4	52.8 ± 4.4	35.0 ± 4.1	4	0	0
Low mixture/control	4	46.5 ± 2.6	32.7 ± 1.7	4	0	0
High mixture/control	4	53.8 ± 6.2	39.0 ± 2.2	4	0	0
Control/CCl <sub>4</sub>	4	55.0 ± 3.9	47.0 ± 7.5	0	4	0
Low mixture/CCl <sub>4</sub>	4	52.5 ± 4.0	41.2 ± 7.4	0	4	0
High mixture/CCl <sub>4</sub>	4	93.5 ± 36.5*	95.5 ± 49.7*	0	4	3

<sup>a</sup> The rats were given deionized water (control), 1% (low mixture), or 10% (high mixture) mixture stock for 14 days and then dosed by gavage a single dose of corn oil (control) or CCl<sub>4</sub> at the rate of 0.075 mL/kg in corn oil; the animals were sacrificed 24 hours later.

<sup>b</sup> AST = aspartate aminotransferase; ALT = alanine aminotransferase.

\* Significantly different from the control/control group, the high mixture/control group, and the control/CCl<sub>4</sub> group, p < 0.01.

From Simmons et al. [13]; Yang et al. [15].

marrow stem cell proliferation following radiation injury resulting from repeated WBI at 200 rad (Table 5). Even 10 weeks after the cessation of the chemical mixture treatment when all hematological parameters were normal, a residual effect of the chemical mixture may still be demonstrated as lower bone marrow stem cell counts following irradiation (Table 6). There is also an indication that even at 1% mixture stock level an enhancement of radiation injury to hematopoiesis may be detected if the exposure period is long enough (Table 7).

These examples provide a clue that the toxicology of chemical mixtures at environmental levels will probably not involve acute toxic responses. It is most likely an insidious effect(s) disrupting the homeostasis of the organism. The exposed animals may appear totally "normal" clinically or based on conventional toxicological endpoints. However, such a subclinical state may provide a basis for enhancement or potentiation of otherwise mild toxic responses from an acute exposure(s) of chemical, physical, and/or biological agents. In this sense, the concept of a generic "promotor" or "enhancer" for any possible toxicity may be advanced for the potential toxicologic consequence of a mixture of environmental pollutants. These findings also raise the possibility for synergistic interaction between a background long-term, low-level chemical mixture exposure and a subsequent acute dose resulting from accidental exposure or drug intake including alcohol abuse.

**TABLE 5. GRANULOCYTE-MACROPHAGE PROGENITOR IN MICE AFFECTED BY GROUNDWATER CONTAMINANTS AND IRRADIATION**

Exposure Levels (% Stock Mixture)	CFU-GM/10 <sup>5</sup> Cells <sup>a</sup>	
	No Irradiation	Two Irradiations <sup>b</sup>
0	113 ± 1	29 ± 1
1	112 ± 1	28 ± 1
5	111 ± 1	21 ± 1*

<sup>a</sup> Female B6C3F<sub>1</sub> mice were treated with a chemical mixture of groundwater contaminants in drinking water daily for 11.5 weeks. The CFE-GM, granulocyte-macrophage colonies were determined in both nonirradiated and irradiated mice (five/group) one week after second irradiation. The CFU-GM, granulocyte-macrophage colonies were assayed by incubating femoral marrow cells in methylcellulose media at 37°C and 7% CO<sub>2</sub> for 7 days. Colonies of >40 cells were enumerated and expressed as mean ± SEM (five mice/group).

<sup>b</sup> Mice received 200 rads of whole-body irradiation at 3.5 and again at 10.5 weeks from the beginning of chemical mixture treatment.

\* Significant at p<0.01 vs. controls by Dunnett's multiple-range test.

**TABLE 6. ALTERATIONS OF GRANULOCYTE-MACROPHAGE PROGENITOR IN MICE RESULTING FROM A RESIDUAL EFFECT FROM AN EARLIER EXPOSURE TO A CHEMICAL MIXTURE OF GROUNDWATER CONTAMINANTS**

Exposure Levels (% Stock Mixture)	CFU-GM/10 <sup>5</sup> Cells <sup>a</sup>		
	2-Days Postexposure (No Irradiation)	10-Weeks Postexposure <sup>b</sup> (No irradiation)	10-Weeks Postexposure (Two Irradiations <sup>c</sup> )
0	112 ± 1	113 ± 1	56 ± 2
1	109 ± 1	112 ± 1	52 ± 2
5	89 ± 1*	112 ± 1	42 ± 2**

<sup>a</sup> The CFU-GM, granulocyte-macrophage colonies were assayed by incubating femoral marrow cells in methylcellulose media at 37°C and 7% CO<sub>2</sub> for 7 days. Colonies of >40 cells were enumerated and expressed as mean ± SEM (five mice/group).

<sup>b</sup> Female B6C3F<sub>1</sub> mice were treated with a chemical mixture of groundwater contaminants in drinking water daily for 15.5 weeks. These mice then were allowed to recover for 10 weeks without chemical mixture treatment.

<sup>c</sup> Mice received 200 rads of whole-body irradiation at two and again at nine weeks following the termination of chemical treatment.

\* Significant at p<0.01 vs. controls by Dunnett's multiple-range test.

## DISCUSSION

Four different experimental approaches for the study of toxicology of chemical mixtures were illustrated in this paper using actual examples of real-life problems. If a scientific panel were

**TABLE 7. ENHANCEMENT OF GROUNDWATER CONTAMINANT-INDUCED MYELOTOXICITY BY REPEATED IRRADIATIONS**

Exposure Levels (% Stock Mixture)	CFU-GM/10 <sup>5</sup> Cells <sup>a</sup>	
	No Irradiation	Four Irradiations <sup>b</sup>
0	112 ± 1	19 ± 1
1	110 ± 1	16 ± 1*
5	83 ± 1**	12 ± 1**

<sup>a</sup> Female B6C3F<sub>1</sub> mice were treated continuously with a chemical mixture of groundwater contaminants in drinking water for 25.5 weeks. The CFU-GM, granulocyte-macrophage colonies were determined in both nonirradiated and irradiated mice (five/group) one week after the fourth irradiation. Results are expressed as mean ± SEM.

<sup>b</sup> Mice received 200 rads of whole-body irradiation at the 3.5-week exposure and again three more times at seven-week intervals.

\* Significant at p<0.05 vs. controls by Dunnett's multiple-range test.

\*\* Significant at p<0.01 vs. controls by Dunnett's multiple-range test.

convened to critique these approaches, each approach would undoubtedly be criticized for shortcomings in the respective designs. Does that mean the particular scientific panel would have better alternatives? The answer is most likely a no! From a different angle, given any of these four problems, different scientists would most likely resort to different approaches, each of which may be weak in some regard. The underlying reason is that for an area as complex and difficult as testing of complex mixtures, there are no perfect protocols. Neither are there any approaches that would please everyone. Yet we, as responsible scientists keenly aware of the problems, cannot wait forever; we must proceed with limited resources (money, time, personnel) and knowledge. Therefore, for scientists interested in engaging research in this area, the following advice is offered: (1) keep an unusually open mind; (2) any experimental approach is a good approach because even if it is a bad design, someone else following the investigator's step may learn from the mistakes; (3) be ready for criticism but do not be discouraged by it; and (4) during experimentation, assume nothing and always anticipate problems. On a more positive note, this area of work is extremely stimulating and gratifying. Those who can withstand the heat may find the reward far outweighs the frustrations.

#### ACKNOWLEDGMENTS

Some of the work mentioned in this report was supported in part or whole by funds from the Comprehensive Environmental Response, Compensation, and Liability Act trust fund by interagency agreement with the Agency for Toxic Substances and Disease Registry, U.S. Public Health Service. Many colleagues in NIEHS, EPA, and other institutes/organizations helped in the studies mentioned in



this paper; their effort and devotion are gratefully acknowledged. We thank Drs L. Birnbaum and D. Morgan of NIEHS for reviewing the manuscript and for their helpful suggestions.

## REFERENCES

- 1 NRC (1988) Complex mixtures. In: Methods for *In Vivo* Toxicity Testing. National Academy Press, Washington, DC, 227 pp.
- 2 Silkworth, J.B., McMartin, D.N., Rej, R., Narang, R.S., Stein, V.B., Briggs, R.G. and Kaminsky, L.S. (1984) Subchronic exposure of mice to Love Canal soil contaminants. *Fundam. Appl. Toxicol.* 4, 231-239.
- 3 Villeneuve, D.C., Valli, V.E., Norstrom, R.J., Freeman, H., Sanglang, G.B., Ritter, L. and Becking, G.C. (1981) Toxicological response of rats fed Lake Ontario or Pacific Coho salmon for 28 days. *J. Environ. Sci. Health*, B16, 649-689.
- 4 Chu, I., Villeneuve, D.C., Valli, V.E., Ritter, L., Norstrom, R.J., Ryan, J.J. and Becking, G.C. (1984) Toxicological response and its reversibility in rats fed Lake Ontario or Pacific salmon for 13 weeks. *J. Environ. Sci. Health*. B19, 713-731.
- 5 Work, S.W., Rothberg, M.R. and Miller, K.J. (1980) Denver's potable reuse project: pathway to public acceptance. *JAWWA* 72, 435-440.
- 6 Lauer, W.C. and Work, S.W. (1983) Denver's Potable Water Reuse Demonstration Project. In: Proceedings of 1983 National Conference on Environmental Engineering, July.
- 7 Lauer, W.C., Roger, S.E. and Ray, J.M. (1984) Denver's Potable Water Reuse Project Current Status. In: Proceedings Water Reuse Symposium III, August.
- 8 City and County of Denver (1988) Contract documents for the potable water reuse demonstration plant: Comprehensive health effects testing program, City and County of Denver acting by and through its Board of Water Commissioners. Prepared by Richard P. Arber Associates, Inc., Denver, Colorado, June.
- 9 Yang, R.S.H. and Rauckman, E.J. (1987) Toxicological studies of chemical mixtures of environmental concern at the National Toxicology Program: Health effects of groundwater contaminants. *Toxicology* 47, 15-34.
- 10 Chapin, R.E., Phelps, J.L., Schwetz, B.A. and Yang, R.S.H. (1989) Toxicology studies of a chemical mixture of 25 groundwater contaminants: (III) Male reproduction study in B6C3F1 mice. *Fund. Appl. Toxicol.* 13, 388-398.
- 11 Germolec, D.R., Yang, R.S.H., (1989) Ackermann, M.P., Rosenthal, G.J., Boorman, G.A., Thompson, M., Blair, P. and Luster, M.I. Toxicology studies of a chemical mixture of 25 groundwater contaminants: (II) Immunosuppression in B6C3F1 mice. *Fundam. Appl. Toxicol.* 13, 377-387.
- 12 Hong, H.L., Yang, R.S.H. and Boorman, G.A. (1989) Myelotoxicity in mice caused by drinking a simulated mixture of groundwater contaminants. *Fed. Proc.* 73rd Annual Meeting of the FASEB, New Orleans, LA, March 19-23.

- 13 Simmons, J.E., Yang, R.S.H., Seely, J.C., Svendsgaard, D. and McDonald, A. (1989) Enhancement of carbon tetrachloride (CCl<sub>4</sub>) hepatotoxicity by prior exposure to a mixture of 25 groundwater contaminants. *The Toxicologist* 9, 58.
- 14 Yang, R.S.H., Goehl, T., Brown, R., Chatham, A., Arneson, D., Buchanan, R. and Harris, R. (1989) Toxicology studies of a chemical mixture of 25 groundwater contaminants: (I) Chemistry development. *Fundam. Appl. Toxicol.* 13, 366-376.
- 15 Yang, R.S.H., Huff, J., Germolec, D.R., Luster, M.I., Simmons, J.E. and Seely, J.C. (1989) Carcinogenicity and Pesticides: Biological Issues in Extrapolation, American Chemical Society Symposium Series, Washington, DC.
- 16 Yang, R.S.H., Goehl, T., Jameson, C.W., Germolec, D., Luster, M.I., Chapin, R., Morrissey, R.E., Schwetz, B.A., Harris, R., Chatham, A., Arneson, D., Moseman, R., Collingsworth, N. and Biglow, D. (1989) Chemical stability and biological suitability of a 25-chemical mixture of groundwater contaminants for animal toxicity studies. *The Toxicologist* 9, 216.
- 17 Ames, B.N., Magaw, R. and Gold, L.S. (1987) Ranking possible carcinogenic hazards. *Science* 236, 271-280.
- 18 Meyer, C.R. (1983) Liver dysfunction in residents exposed to leachate from toxic waste dump. *Environ. Health Perspect.* 48, 9-13.

## TOXICOLOGICAL EVALUATION OF COMPLEX INDUSTRIAL WASTES: IMPLICATIONS FOR EXPOSURE ASSESSMENT

David M. DeMarini, Jane E. Gallagher, Virginia S. Houk, and Jane Ellen Simmons

*Health Effects Research Laboratory, U.S. Environmental Protection Agency,  
Research Triangle Park, NC 27711*

### SUMMARY

We evaluated a variety of short-term bioassays to construct a battery of tests that could be used for assessing the biological effects of potentially hazardous complex industrial wastes. Ten samples were studied for hepatotoxicity; these samples and an additional five were studied for mutagenicity. Although the data are limited to these samples, the results suggest that the *Salmonella* assay (strain TA98) or a prophage-induction assay (both in the presence of S9) in combination with determination of relative liver weight and levels of a set of serum enzymes in rats may provide a battery of tests suitable to characterize complex industrial wastes for mutagenic and hepatotoxic potential. The biological activities exhibited by the wastes were not readily predicted by the chemical profiles of the wastes, emphasizing the importance of characterizing potentially hazardous complex industrial wastes by both chemical and biological means. DNA from liver, lung, and bladder of rats exposed to some of the wastes was analyzed by the <sup>32</sup>P-postlabeling technique for the presence of DNA adducts. A waste that produced mutagenic urine produced a DNA adduct in bladder DNA. The implications of this approach for assessment of exposure to complex hazardous waste mixtures are discussed.

### INTRODUCTION

In the United States, wastes are classified as hazardous if they possess one of a number of physical characteristics or if they are composed of certain industrial process wastes or contain specifically regulated chemicals [1]. Guidelines for characterizing the biological toxicity of hazardous wastes have not yet been promulgated; however, knowledge of the potential biological toxicity of a hazardous waste could augment the available chemical characterization and provide relevant information regarding potential health effects.

Because hazardous wastes may contain a wide array of chemical mutagens, and because no single bioassay will detect all chemical classes of mutagens, several short-term assays with different genetic endpoints may be advantageous for screening hazardous wastes for genotoxic potential. Consequently, combinations of short-term assays have been proposed as possible screening batteries for hazardous wastes [2]. Nonetheless, most investigations of the genotoxicity of hazardous wastes

have not used a battery of assays. Instead, most studies have used only the *Salmonella* assay [3,4], although mammalian cells and other eukaryotic assays have been used to a limited extent [5- 7].

In addition to genotoxicants, many hazardous wastes also may contain chemicals that are suspected or known hepatotoxicants. Hepatomegaly and abnormal liver function, with return to normal on cessation of exposure, have been associated with human exposure to hazardous waste [8-10]. The liver was a primary target organ in mice exposed subchronically to Love Canal soil [11]. Thus, we have evaluated the acute hepatotoxicity of 10 chemically characterized wastes and assessed whether the chemical analysis was predictive of the biological results.

This report summarizes the efforts of our laboratory to determine the usefulness of a variety of short-term bioassays for assessing the genotoxic and hepatotoxic potential of hazardous industrial wastes. Most of the wastes we evaluated have been partially chemically characterized, permitting comparisons of biological activity and chemical composition. The chemical analysis indicated that many of the wastes contained carcinogenic metals, chlorinated compounds, and solvents that are detected poorly by the *Salmonella* assay [12-14]. Thus, in addition to the *Salmonella* assay, we included a prophage-induction assay in *Escherichia coli* that may be more sensitive than *Salmonella* for these classes of compounds [15,16].

Because *in vivo* mammalian metabolism may be a critical factor in the generation of mutagenic metabolites from complex hazardous wastes, we studied the mutagenicity of urine from rats administered hazardous wastes by gavage. Because most batteries include mammalian cell assays, we evaluated a series of such assays and compared the results to those obtained with *Salmonella* for a set of four diverse hazardous wastes. The advantages and disadvantages of testing crude versus extracted waste samples are discussed along with some of the problems encountered when trying to select appropriate test methodologies for a wide variety of hazardous waste types.

Measuring the extent of exposure of populations to complex hazardous wastes is of vital importance. Thus, we explored the possible use of the recently developed <sup>32</sup>P-postlabeling procedure [17,18] to detect DNA adducts from tissues of rats exposed to two of the hazardous wastes. The implications of these results for exposure assessment are discussed.

## **MATERIAL AND METHODS**

### ***Waste and Waste Extracts***

Two sets of hazardous waste samples were used for these studies (Table 1). The first set was obtained from Edward L. Katz, Hazardous Waste Engineering Research Laboratory, U.S. Environmental Protection Agency, Cincinnati, OH. Three of the waste samples (A, B, and C) were from three different industrial manufacturers. The remaining 12 samples (D through O) were from

three commercial hazardous waste incineration facilities that burn a mixture of hazardous wastes composited from a variety of individual sources and from one incinerator whose waste source was not specified. Each waste sample was analyzed for the presence of a limited number of priority organics and/or metals identified in the U.S. EPA Appendix VIII list of priority pollutants (Table 2) [19]. Dichloromethane (DCM) extracts were solvent exchanged into dimethyl sulfoxide (DMSO), and crude wastes and waste extracts were tested in the *Salmonella* assay. Crude wastes were evaluated in the phage-induction assay and administered by gavage to rats to determine hepatotoxicity and to detect mutagenic urine [20].

The second set of hazardous waste (Table 1) consisted of four wastes from four different industries: coke plant, herbicide manufacturing, pulp and paper mill, and oil refining. These wastes were obtained from Dr. M. McKown, Battelle Columbus Laboratories, Columbus, OH. DCM extracts were prepared as described [21] and solvent exchanged into DMSO for bioassay. These four waste extracts were tested in *Salmonella* and in the mammalian cell assays.

**TABLE 1. PHYSICAL DESCRIPTION OF HAZARDOUS WASTES**

<b>Waste</b>	<b>Description</b>
<b>Waste Set 1</b>	
A	Black, thin oil
B	Black, oily liquid
C	Black pourable tar
D	Composite of aqueous wastes; watery liquid with oil drops
E	Composite of organic wastes; thin, dark liquid
F and G	Organic wastes; biphasic gray sludge with reddish-brown liquid
H and I	Aqueous wastes; thin, gray slurry
J	Composite of organic wastes; gray, thick liquid with suspended solids
K	Similar to J, but lighter in color and thinner
L and M	Composite of organic wastes; black, thin, pourable tar
N and O	Composite of aqueous wastes; clear, watery liquid
<b>Waste Set 2</b>	
P	Light-brown liquid with suspended solids from coke plant
Q	Brown-clear liquid from herbicide manufacturing plant
R	Brown semi-solid with wood chips from pulp and paper mill
S	Dark liquid with brown flocculant and oil drops from oil refining plant

**TABLE 2. CONCENTRATION OF CHEMICALS AND METALS IDENTIFIED IN HAZARDOUS WASTES (µg/g)**

Chemical/Metal	Company 1	Company 2	Company 3	Hazardous Waste Incineration Facilities											
				1		2		3		4		C Aqueous			
				Aqueous	Organic	Organic	Aqueous	Organic	Organic	Organic	Organic	N	O		
				A	B	C	D	E	F	G	H	I	J	K	L
Aniline		14000	550000												
Benzyl Chloride	3000														
Bis (2-ethylhexyl) phthalate		500		<100	3800							200	230		
Butylbenzyl phthalate				<100	320	120	450	<5	8	160	140				
Chlordane												<60	<60		
Chlorophenylisocyanate		21000													
Cresol(s)										2000	2500				
Diethylphthalate						620	1300	240	240						
m-Dichlorobenzene		23000													
o-Dichlorobenzene		46000													
p-Dichlorobenzene		59000													
m-Dinitrobenzene				<100											
Diphenylamine			6200												
2,4-Dimethylphenol										500	2000				
Hexachlorobutadiene												<10	<10		
Hexachloroethane	560														
Hexachlorocyclopentadiene												<10	<10		
Isophorone				<100	110										
Mononitrobenzene			<100												
Naphthalene	<100			<100	350	250	450	44	49	450	490	38	33		
Phenol				34000	1000	1500	1700	1800	2900						
Phenylenediamine			2300												
Phenylisocyanate		160000													
Trans 1,4-dichloro-2-butene	59000														
1,2,4-Trichlorobenzene		290													
Benzene				<3	260							46000	58000	<10	<10
<sup>b</sup> Carbon tetrachloride	68000	44000		<2	6000	3700	4400	<10	<10	5900	5700	9100	11300	<10	<10
Chlorobenzene		4100										390	500	<10	<10
Chloromethane		1200													
Chloroform	2900					170	270	21	22			110	60	<10	<10
Cis-1,4-dichloro-2-butene	18000														
Methylene Bromide												<10	<10	3100	4700
Methylene chloride	21000											100	340	44	60
Methyl Ethyl Ketone				27	9700					18000	38000				
Tetrachloroethylene	11000			<1	28	7100	9800	1600	1300	7900	8100	87	150	<10	<10
Toluene	240000			110	2400	32000	45300	2900	2700	56000	48000	160000	390000	22	20
1,1,1-Trichloroethane	<100			<100						24000	16000	330	230	<10	<10
<sup>b</sup> Trichloroethylene	4000	40000		<1	5500	3700	4400	90	85	8100	7800	8300	10300	<10	<10
Ag	<3					<1	<1	<1	<1			<1	<1		
As	<24					<20	<20	<20	<20	<14	<14	<23	<23		
Ba	<7					110	140	6	7	1160	1150	990	1100		
Be	<2					<1	<1	<1	<1	<1	<1	<1	<1		
Cd	<5					6	6	<1	<1	153	15	49	55		
Cr	<5					50	57	3	3	431	425	250	290		
Hg	<22					<10	<10	<10	<10	<4	<4	<50	<50		
Ni	<68					7	7	2	2	26	27	<4	<4		
Pb	<19					140	150	<10	11	1830	1800	1200	1300		
Sb	<12					58	61	<10	<10	437	373	<24	<24		
Se	<470					340	<100	<100	<100	<21	<21	<160	<160		
Tl	<23					<20	<20	<20	<20	<9	<9	<22	<22		
Si										<1	<1				
pH		2		8		7	7	6	7				7	7	7
Water(%)	2		5	94	3	38	48	95	67	21	23	5	5	94	96
Characterized Mass (%)	45	39	61	94	6	43	54	96	68	33	36	27	52	94	96

<sup>a</sup>Data from (19)

<sup>b</sup>Waste samples B, E, F, G, J, K, L, and M were spiked with these two chemicals

<sup>c</sup>Previous versions of this Table (20, 23, 27) incorrectly showed values for wastes N and O for the following compounds: Bis-(2-ethylhexyl)-phthalate, chlordane, hexachlorobutadiene, hexachlorocyclopentadiene, and naphthalene. Wastes N and O were not analyzed for the presence of these five compounds.

### **Urine and Urine Extracts**

Male Fischer 344 (F-344) rats were dosed with four different doses of waste C for 10 days before collecting 24-h urine samples from three rats per dose. However, the available amount of waste samples permitted the use of this protocol for only waste C. For nine other wastes, a single dose of the crude waste was administered by gavage to male F-344 rats. All urines were collected on dry ice for 24 h, centrifuged, filter sterilized, and frozen at -20°C. As reviewed previously [20],  $\beta$ -glucuronidase generally has been required to observe rodent urinary mutagenicity. Thus, all 10 raw urines were tested for mutagenicity in *Salmonella* TA98 with S9 and  $\beta$ -glucuronidase. In case the addition of  $\beta$ -glucuronidase to the plate was inadequate to identify mutagenic urine from rats exposed to the complex wastes, six of the raw urines also were extracted and tested as follows.

One milliliter of  $\beta$ -glucuronidase (Sigma Type VII from *E. coli*) at a concentration of 1000 units/mL of potassium phosphate buffer (0.15 M, pH 7.4) was added to 2 to 10 mL of thawed urine, and the mixtures were incubated with shaking for 1 h at 37°C. Then, each mixture was poured through two serially connected Sep-Pak C<sub>18</sub> cartridges (Waters Associates, Milford, MA) followed by water. Concentrates then were eluted with methanol, the methanol was evaporated, and the residue was solvent exchanged into a volume of DMSO to produce 5- x concentrates, which were stored at -20°C.

### **Salmonella Assay**

The *Salmonella* plate-incorporation assay was performed as described [22]. Wastes and waste extracts were assayed at least twice (on separate days), in duplicate, in strains TA98 and TA100 in the presence and absence of Aroclor 1254-induced Sprague-Dawley rat liver S9 (~1 mg of protein/plate) prepared as described [22]. Urines and urine extracts were assayed in strain TA98 in the presence of S9 and  $\beta$ -glucuronidase (1000 units/plate). Raw urine and urine extracts were tested twice (on separate days), each individually due to small sample volumes. A dose-related increase in the number of revertants per plate was considered a positive response.

### **Phage-Induction Assay**

The Microscreen phage-induction assay developed by Rossman et al. [15] was performed using modifications described previously [23]. The two bacterial strains used for this assay are derived from *E. coli* B/r. WP2<sub>5</sub>( $\lambda$ ) is a lambda lysogen of WP2<sub>5</sub> (*trpE*, *uvrA*); SR714 (*trpE*, *uvrD*<sub>3</sub>) is the indicator strain. The lysogenic strain was exposed overnight to various dilutions of the crude waste both in the presence and absence of S9. Following exposure, each suspension was sampled for the presence of lambda particles by plating onto the indicator strain. The criterion for a positive response was an

increase in the number of induced plaque-forming units per plate that reached or exceeded the upper limit of the 99% confidence interval based on the negative controls.

### ***Mammalian Cell Assays***

Because of the limited amount of DCM extract of each of the four wastes used in the mammalian cell assays, and because of the cost of performing a set of such assays with each extract, it was not possible to perform the assays according to currently accepted protocols or established guidelines. Instead, limited protocols were used that required a minimum number of setups and amount of sample to permit an extract to be identified as a presumptive positive or negative. In order to conserve sample, the dose range for each extract was estimated for all of the assays by performing a preliminary cytotoxicity study in Chinese hamster ovary (CHO) cells. The assays then were performed only once with only a few doses of extract and in the presence of S9. Otherwise, the assays were performed essentially as described below.

The L5178Y/TK<sup>+</sup>-3.7.2C mouse lymphoma assay was performed in the presence of S9 as described [24]. Cytogenetic effects induced by the four waste extracts in the presence of S9 were determined by scoring for chromosomal aberrations and sister chromatid exchanges (SCEs) in CHO-WBL cells as described [25]. The ability of the four waste extracts to induce morphological transformation in BALB/c-3T3 cells was determined as described [26]. Metabolic activation was provided by X-irradiated rat liver cells, and 12-O-tetradecanoyl-13-phorbol acetate was used to promote the formation of the transformed phenotype.

### ***Hepatotoxicity Assays***

Ten waste samples were evaluated for hepatotoxicity as described [27]. Briefly, male F-344 rats were exposed by gavage to a single dose of waste that ranged from 0.5 to 5 mL/kg. Twenty-four hours after dosing, the rats were weighed, anesthetized with 50 mg/kg of sodium pentobarbital ip, and exsanguinated from the abdominal aorta. Serum chemistry profiles were obtained for concentrations of total bilirubin (BILI) and activities of aspartate aminotransferase (AST), alanine aminotransferase (ALT), alkaline phosphatase (ALKPH), and lactate dehydrogenase (LDH). The activity of ornithine carbamyl transferase (OCT) was determined as described [27].

The liver was excised quickly, rinsed in saline, blotted, and weighed, and then relative liver weight (liver-to-body-weight ratio) was determined. Samples from the left lobe were taken for open histopathological examination; lesions were evaluated on hematoxylin- and eosin-stained tissue sections. Data were analyzed as described by Simmons et al. [27].



### **DNA Adduct Analysis**

<sup>32</sup>P-ATP (3000 Ci/mmole, 10 mCi/mL of aqueous solution containing 5 mM 2-mercaptoethanol) was obtained from Amersham, Arlington Heights, IL. Polyethyleneimine cellulose thin-layer chromatography plates were prepared as described previously by Gupta et al. [28] except that the PEI solution (50% aqueous) was obtained from Aldrich Chemical Co., Milwaukee, WI. Micrococcal nuclease and nuclease P1 were purchased from Sigma, St. Louis, MO; calf spleen phosphodiesterase was from Boehringer Mannheim, Indianapolis, IN; T4 polynucleotide kinase was from Pharmacia, Inc., Piscataway, NJ; and <sup>32</sup>P-labeled orthophosphate was purchased from Amersham. All other chemicals were of analytical grade.

Because of limited sample, one rat per treatment group was gavaged with waste M (5 mL/kg) or waste L (2.5 mL/kg) and then sacrificed 24 h following exposure. (These wastes were selected primarily because they produced mutagenic urine). DNA was extracted from lung, liver, and bladder according to the method of Gupta et al. [28]. DNA samples were analyzed for DNA adducts using two versions of the <sup>32</sup>P-postlabeling procedure [17, 18] with minor modifications as reported previously by Gallagher et al. [29].

Briefly, DNA samples (2.5 to 5.0 µg) were enzymatically digested to deoxyribonucleoside 3' monophosphates with micrococcal endonuclease and spleen phosphodiesterase. Then the digests were either extracted with butanol or treated with nuclease P1. The mononucleotides were <sup>32</sup>P-postlabeled (50 µCi γ-ATP) by polynucleotide kinase-mediated phosphorylation. Thin-layer chromatography was used to separate the adducts. Areas of radioactivity were located by autoradiography, cut out, measured by scintillation counting, and the adduct levels were quantified.

### **RESULTS AND DISCUSSION**

The quantitative results of our genotoxicity studies of these wastes and waste extracts have been published elsewhere [20, 21, 23]; the qualitative responses are summarized here. Table 3 summarizes the mutagenic responses in *Salmonella* of the first set of wastes and waste extracts, the mutagenic responses in *Salmonella* of the urine or urine extracts from rats gavaged with these wastes, and the responses of these wastes in the phage-induction assay. Table 4 summarizes the genotoxic responses of the second set of wastes in *Salmonella* and in the mammalian cell assays.

Liquid extraction, as opposed to solid-phase extraction, was the only extraction methodology that was suitable for these diverse wastes. However, as discussed previously [20], DCM may not be a suitable solvent for all types of wastes. Table 3 shows that DCM failed to extract mutagenic activity from five wastes (L, M, G, F, and O) that were mutagenic in their crude, unextracted form. Nearly 80% of these wastes would have been detected as mutagenic if only the crude wastes had been tested. The additional time and expense required to prepare organic extracts of these wastes did not

produce extracts that yielded much additional information that was not obtainable from the crude wastes.

**TABLE 3. GENOTOXIC RESPONSES OF CRUDE WASTES/EXTRACTS AND RAW URINE/EXTRACTS**

Wastes	Mutagenic Responses in <i>Salmonella</i>										Phage-Induction Response	
	Crude Wastes				Waste Extracts				Urines <sup>a</sup>			
	TA98		TA100		TA98		TA100		Raw	Ext.	+ S9	-S9
	+ S9	-S9	+ S9	-S9	+ S9	-S9	+ S9	-S9				
C	-	-	+	+	+	-	+	-	+	+	+	+
L	+	-	-	-	-	-	-	-	+	+	+	+
M	+	-	-	-	-	-	-	-	+	+	+	+
G	+	+	-	-	-	-	-	-	-	-	+	+
O	+	-	-	-	-	-	-	-	-	-	-	-
E	-	-	-	-	-	-	-	-	-	-	NT <sup>b</sup>	NT
H	-	-	-	-	+	+	-	-	-	NT	+	+
J	-	-	-	-	+	-	-	-	-	NT	+	-
K	-	-	-	-	-	-	-	-	-	NT	-	-
B	-	-	-	-	NT	NT	NT	NT	-	NT	+	+
A	-	-	+	+	-	-	+	+	NT	NT	+	+
F	-	-	+	+	-	-	-	-	NT	NT	+	+
D	-	-	-	-	-	-	-	-	NT	NT	+	-
I	-	-	-	-	-	-	-	-	NT	NT	+	+
N	-	-	-	-	-	-	-	-	NT	NT	-	-

<sup>a</sup> Urines tested in strain TA98 in the presence of S9 and  $\beta$ -glucuronidase.

<sup>b</sup> Not tested.

**TABLE 4. GENOTOXIC RESPONSES OF WASTE EXTRACTS IN *SALMONELLA* AND MAMMALIAN CELLS**

Wastes	Mutagenicity in <i>Salmonella</i>				Genotoxicity in Mammalian Cells			
	TA98		TA100		Mutagenicity in L5178Y/TK +/-	Cytogenetic Effects		
	+ S9	-S9	+ S9	-S9		SCEs	Chromosomal Aberrations	Transformation
P	+	-	+	-	+	+	+	-
Q	+	-	-	-	+	-	-	-
R	+	-	-	-	+	+	-	-
S	-	-	-	-	+	+	-	-

However, not all wastes can be tested directly due to microbial contamination or physical state. For example, highly viscous wastes are difficult to pipette and dilute, complicating the generation of reproducible, quantitative results. Also, wastes with high or low pH may be highly toxic to cells and may have to be neutralized before bioassay. Thus, extraction and fractionation procedures will be necessary for some, if not most, hazardous wastes in order to examine their biological activity. An innovative approach involving fractionation by thin-layer chromatography coupled with the *Salmonella* assay has been shown to be useful with some wastes [4].

Judicious selection of a test matrix (and battery) is required in order to screen hazardous wastes in a cost-effective manner without an unacceptable loss of detection capability. For example, all of the wastes and waste extracts that were mutagenic in *Salmonella* in Table 3 would have been detected if they had been tested only in the presence of S9 (Table 3), reducing the testing matrix in half. Considering the results with both strains ( $\pm$  S9) with the crude wastes and waste extracts, there were nine mutagenic wastes identified, seven of which were mutagenic in TA98 + S9. Thus, if the crude wastes and extracts had been studied only in the presence of S9, nearly 80% of the mutagenic wastes identified with the present matrix would have been identified.

Based on the wastes tested here, the urinary mutagenesis assay did not appear to be useful as a rapid screen to replace or complement testing the wastes or waste extracts directly in *Salmonella* (Table 3). Extracting the urines by means of C<sub>18</sub>/methanol elution did not identify a urine as mutagenic that was not identified as mutagenic from studies with raw urine (Table 3). Considering the time and expense of performing the urinary mutagenesis assay, this assay was not a useful adjunct to testing the waste or waste extracts directly for mutagenicity.

The phage-induction assay in *E. coli* detected five crude waste samples that were not mutagenic in *Salmonella* (Table 3). As described in the INTRODUCTION, the Microscreen phage-induction assay has been shown to detect some carcinogenic metals and chlorinated organics and solvents that are not mutagenic in *Salmonella*. Metals and compounds of these types are present in most of the waste samples studied here [19], and the ability of some of these compounds to induce prophage may account for the detection by the phage-induction assay of the five additional waste samples. Accumulating evidence indicates that prophage induction (and the SOS response in general) is a broader genetic endpoint than reverse mutation in bacteria [30-32], making it especially useful for screening chemically diverse waste.

A comparison of the genotoxic responses of DCM extracts of four wastes in the *Salmonella* assay to their responses in a set of mammalian cell assays indicates that the inclusion of mammalian cell assays may not have improved significantly the ability to detect the genotoxicity of the wastes beyond that afforded by the *Salmonella* assay alone (Table 4). Waste S was the only waste detected

by the mammalian cell assays that was not detected by the *Salmonella* assay. The BALB/c-3T3 transformation assay did not detect any of the extracts as positive, even though all four were genotoxic in one or more assays. Based on these limited results, it appears that this assay may not be useful for screening hazardous wastes.

Currently, there is only a small data base on the use of mammalian cell assays with complex mixtures, let alone with hazardous wastes. Perhaps some of the reasons for this are that mammalian cell assays are difficult to use with toxic complex mixtures and are more costly and time-consuming to perform than microbial assays. Recently, two studies [33,34] have shown that mammalian cell assays may not provide much more additional detection capability than that afforded by the *Salmonella* assay for pure compounds. Our results with these hazardous wastes suggest that the same may be true for complex mixtures.

The results of the hepatotoxicity study have been published [27] and are summarized in Table 5. Based on histopathological evaluation of the liver, eight of the 10 wastes were hepatotoxic (Table 5). Under the experimental conditions, wastes H and O were nonhepatotoxic. Nine of the ten wastes caused an increase in relative liver weight, and various wastes increased the serum concentrations of different combinations of the serum enzymes and BILI (Table 5).

TABLE 5. SUMMARY OF HEPATOTOXIC EFFECTS OF WASTES

Waste	N <sup>a</sup>	Dose (mL/kg)	Histo-pathology	Relative Liver Weight	Serum Indicators of Hepatic Injury					
					AST	ALT	LDH	ALKPH	OCT	BILI
A	5	1	+ <sup>b</sup>	+	- <sup>c</sup>	-	+	+	+	+
B	6	1	+	+	+	-	-	-	-	-
E	4	2.5	+	+	-	-	-	+	-	-
	2	5	+	+	+	+	-	+	-	+
G	5	5	+	+	-	-	-	-	-	+
H	6	5	-	+	-	-	-	-	-	-
J	6	0.5	+	+	+	+	-	-	+	-
K	6	0.5	+	+	+	+	-	+	+	-
L	4	2.5	+	+	+	-	+	-	-	-
M	5	5	+	+	+	+	+	+	-	-
O	6	5	-	-	-	-	-	-	-	-

<sup>a</sup> N = Number of rats used for evaluation of hepatotoxicity.

<sup>b</sup> A significant increase compared to concurrent controls.

<sup>c</sup> No changes compared to concurrent controls.

With histopathology as the criterion of hepatotoxicity, the best single predictor of hepatotoxicity was relative liver weight [27]. Assessed individually, single serum indicators could not distinguish hepatotoxic from nonhepatotoxic wastes. The inability of any single serum indicator to

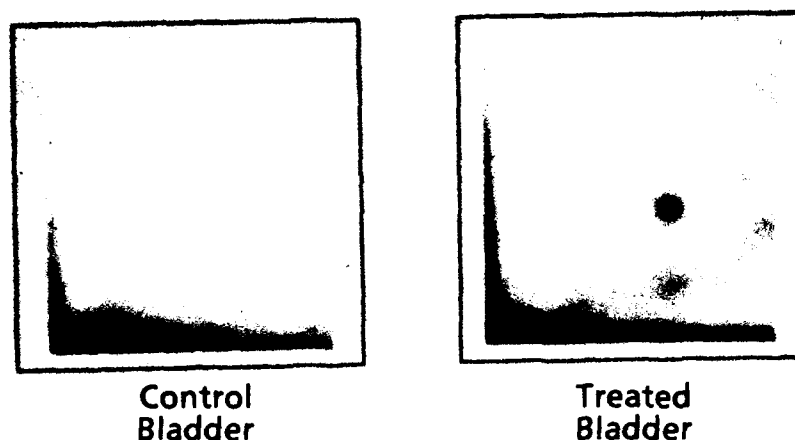
identify correctly the hepatotoxic samples was due to false negatives rather than to false positive [27]. Therefore, the five commercially obtained serum indicators (AST, ALT, LDH, ALKPH, and BILI) assessed collectively to determine how well they predicted hepatotoxicity as a battery. The serum battery was considered positive if at least one serum indicator was positive, and it was considered negative if all of the serum indicators were negative. As a battery, the serum indicators correctly identified the eight hepatotoxic waste samples and the two nonhepatotoxic waste samples [27]. The advantages and disadvantages of the hepatic indicators for screening purposes have been discussed [35]; histopathologic evaluation was recommended rather than the serum battery in animal studies except when results are required before pathology results are available. The potential usefulness of the serum battery for monitoring human exposure to hazardous waste has been noted by Simmons et al. [35].

The chemical characterization available for these wastes (Table 2) [19] is more extensive than would ordinarily be available for most complex wastes and allowed for a limited assessment of the relationship between chemical characterization and biological effects. Comparing observed toxicity to that expected, based on a limited understanding of the chemical composition of the waste, is important because one method used by the U.S. EPA to identify wastes as hazardous is based on partial chemical characterization [36]. As discussed extensively elsewhere [20,23,27], the observed biological effects (i.e., genotoxicity, cytotoxicity, and hepatotoxicity) were not readily predicted from the chemical characterization data.

These results have important implications for assessing exposure to complex mixtures such as these hazardous wastes. As discussed previously, the biological activities of these mixtures are not readily predictable from knowledge of some of the chemicals present in the mixtures. Likewise, it is unlikely that monitoring individuals for exposure to one or a few chemicals will provide highly informative data regarding individual exposure to such complex mixtures. One possible approach to determining exposure to complex mixtures that contain a variety of mutagenic and carcinogenic compounds is the use of the <sup>32</sup>P-postlabeling technique described previously [17,18].

In order to examine the feasibility of this technique for exposure assessment, we have analyzed DNA from lung, liver, and bladder of rats exposed to wastes M or L, which were mutagenic, caused DNA damage, were hepatotoxic, and produced mutagenic urine. One major DNA adduct was detected in rat bladder DNA following the oral administration of 2.5 mL/kg of waste L (Figure 1). The relative adduct level was determined to be 3.4 adducts/ 10<sup>9</sup> nucleotides. DNA adducts were not detected in lung or liver DNA from the rat gavaged with waste L. No DNA adducts were detected in lung, liver, or bladder DNA from the rat gavaged with waste M. It is interesting that waste L, which produced mutagenic urine that was relatively potent (259 revertants/mL of raw urine and 1586 revertants/mL equivalent of C<sub>18</sub>/methanol concentrate) [20], also produced detectable DNA adducts

in the bladder. Apparently, mutagens in the urine were able to bind covalently to bladder tissue DNA.



**Figure 1. Autoradiogram of PEI Cellulose Thin-Layer Chromatography Fingerprint of a DNA Adduct Detected in Rat Bladder DNA 24 h after Gavage by Waste L. Autoradiogram was developed for 4 days at -80°C.**

One main purpose in these studies has been to determine which individual bioassays or groups of bioassays could serve as inexpensive, rapid-screening tools to assess the toxicity of a large number of chemically different industrial wastes. The limited number of hazardous wastes that we have studied here cannot be considered to represent the "universe" of wastes. In addition, there are many other bioassays that we have not yet examined that may be useful for screening hazardous wastes. Given these limitations, however, our studies suggest that the *Salmonella* assay using strain TA98 in the presence of S9 or the phage-induction assay in the presence of S9 may be useful in screening wastes for genotoxicity. Based on the available limited data, relative liver weight and a battery of serum indicators appeared potentially useful for routine screening of complex mixtures for hepatotoxicity.

The combination of this hepatotoxicity assay with one of the genotoxicity assays might provide a cost-effective, rapid, and simple battery of bioassays that could be used routinely to characterize large numbers of waste samples. The possible role of  $^{32}\text{P}$ -postlabeling for determining adducts resulting from exposure to hazardous wastes should be explored further in order to determine the usefulness of this approach for assessing exposure.

Both government [37-39] and industry [2,40] have recognized the important role that short-term tests could play in the toxicological assessment of hazardous wastes. We have reported here on the use of only genotoxicity and hepatotoxicity bioassays to evaluate hazardous wastes; however, wastes may induce other biological effects, such as neurotoxicity. Additional investigations are needed to explore the effects of hazardous wastes on these and other toxicological endpoints. The

results presented here suggest that short-term bioassays may be useful adjuncts to chemical analysis in identifying wastes as hazardous. They also illustrate the importance of developing means of assessing exposure to complex mixtures rather than to single chemicals.

## REFERENCES

- 1 Federal Register (1980) Hazardous waste and consolidated permit regulations, Vol. 45, No. 98, May 19, 33066-33133.
- 2 Barfknecht, T.R. and Naismith, R.W. (1984) Methodology for evaluating the genotoxicity of hazardous environmental samples. *Hazard. Waste* 1, 93-109.
- 3 Nestmann, E.R., Lee, E.G.H., Matula, T.I., Douglas, G.R. and Mueller, J.C. (1980) Mutagenicity of constituents identified in pulp and paper mill effluents using the *Salmonella* and mammalian-microsome assay. *Mutat. Res.* 79, 203-212.
- 4 Houk, V.S. and Claxton, L.D. (1986) Screening complex hazardous wastes for mutagenic activity using a modified version of the TLC/*Salmonella* assay. *Mutat. Res.* 169, 81-92.
- 5 Hopke, P.K., Plewa, M.J., Johnston, J.B., Weaver, D., Woods, S.G., Larson, R.A. and Hinesly, T. (1982) Multitechnique screening of Chicago municipal sewage sludge for mutagenic activity. *Environ. Sci. Technol.* 16, 140-147.
- 6 DeMarini, D.M., Brimer, P.A. and Hsie, A.W. (1984) Cytotoxicity and mutagenicity of coal oils in the CHO/HGPRT assay. *Environ. Mutagen.* 6, 517-527.
- 7 Donnelly, K.C., Brown, K.W., Thomas, J.C. and Davol, P. (1985) Evaluation of the hazardous characteristics of two petroleum wastes. *Hazard. Waste Hazard. Matr.* 2, 191-208.
- 8 Clark, C.S., Meyer, C.R., Gartside, P.S., Majeti, V.A., Specker, B., Balistreri, W.F. and Elia, V.J. (1982) An environmental health survey of drinking water contamination by leachate from a pesticide waste dump in Hardeman County, Tennessee. *Arch Environ. Health* 37, 9-18.
- 9 Meyer, C.R. (1983) Liver dysfunction in residents exposed to leachate from a toxic waste dump. *Environ. Health Perspect.* 48, 9-13.
- 10 Harris, R.H., Highland, J.H., Rodricks, J.V. and Papadopoulos, S.S. (1984) Adverse health effects at a Tennessee hazardous waste disposal site. *Hazard. Waste* 1, 183-204.
- 11 Silkworth, J.B., McMartin, D.M., Rej, R., Narang, R.S., Stein, V., Briggs, R.G. and Kaminsky, L.S. (1984) Subchronic effects of mice to Love Canal soil contaminants. *Fundam. Appl. Toxicol.* 4, 231-239.
- 12 Kier, L.D., Brunsick, D.J., Auletta, A.E., Von Halle, E.S., Brown, M.M., Simmon, V.F., Dunkel, V., McCann, J., Mortelmans, K., Prival, M., Rao, T.K. and Ray, V. (1986) The *Salmonella typhimurium*/mammalian microsome assay. A report of the U.S. Environmental Protection Agency Gene-Tox Program. *Mutat. Res.* 168, 69-240.
- 13 Zeiger, E. and Tennant, R.W. (1986) Mutagenesis, clastogenesis, carcinogenesis: Expectations, correlations, and relations. In: C. Ramel, B. Lambert, and J. Magnusson (Eds.), *Genetic Toxicology of Environmental Chemicals, Part B*, Alan R. Liss, New York, pp. 75-84.

- 14 Claxton, L.D., Stead, A.G. and Walsh, D. (1988) An analysis by chemical class of *Salmonella* mutagenicity tests as predictors of animal carcinogenicity. *Mutat. Res.* 205, 197-225.
- 15 Rossman, T.G., Molina, M. and Meyer, L.W. (1984) The genetic toxicology of metal compounds: I. Induction of  $\lambda$  prophage in *E. coli* WP2<sub>3</sub>( $\lambda$ ). *Environ. Mutagen.* 6, 59-69.
- 16 Houk, V.S. and DeMarini, D.M. (1987) Induction of prophage lambda by chlorinated pesticides. *Mutat. Res.* 187, 141-149.
- 17 Gupta, R.C. (1985) Enhanced sensitivity of <sup>32</sup>P-postlabeling analysis of aromatic carcinogen: DNA adducts. *Cancer Res.* 45, 5656-5662.
- 18 Reddy, M.V. and Randerath, K. (1986) Nuclease P1-mediated enhancement of sensitivity of <sup>32</sup>P-postlabeling test for structurally diverse DNA adducts. *Carcinogenesis* 7, 1543-1551.
- 19 U.S. Environmental Protection Agency (1984) Performance evaluation of full-scale incinerators. National Technical Information Center Publication No. PB85-129500.
- 20 DeMarini, D.M., Inmon, J.P., Simmons, J.E., Berman, E., Pasley, T.C., Warren, S.H. and Williams, R.W. (1987) Mutagenicity in *Salmonella* of hazardous wastes and urine from rats fed these wastes. *Mutat. Res.* 189, 205-216.
- 21 DeMarini, D.M., Brusick, D.J. and Lewtas, J. (1987) Use of limited protocols to evaluate the genotoxicity of hazardous wastes in mammalian cell assays: Comparison to *Salmonella*. *J. Toxicol. Environ. Health* 22, 225-231.
- 22 Maron, D.M. and Ames, B.N. (1983) Revised methods for the *Salmonella* mutagenicity test. *Mutat. Res.* 113, 173-215.
- 23 Houk, V.S. and DeMarini, D.M. (1988) Use of the Microscreen phage-induction assay to assess the genotoxicity of 14 hazardous industrial wastes. *Environ. Mol. Mutagen.* 11, 13-29.
- 24 Clive, D., Johnson, K.O., Spector, J.F.S., Batson, A.G. and Brown, M.M.M. (1979) Validation and characterization of the L5178Y/TK <sup>+</sup>/<sub>-</sub> mouse lymphoma mutagen assay system. *Mutat. Res.* 59, 61-108.
- 25 Galloway, S.M., Bloom, A.D., Resnick, M., Margolin, B.H., Nakamura, F., Archer, P. and Zeiger, E. (1985) Development of a standard protocol for *in vitro* cytogenetic testing with Chinese hamster ovary cells: Comparison of results for 22 compounds in two laboratories. *Environ. Mutagen.* 7, 1-51.
- 26 Matthews, E.J., DelBalzo, T. and Rundell, J.O. (1985) Assays for morphological transformation and mutation to ouabain resistance of Balb/c-3T3 cells in culture. In: J. Ashby, F.J. de Serres, M. Draper, M. Ishidate, B.H. Margolin, B.E. Matter, and M.D. Shelby (Eds.), *Evaluation of Short-Term Tests for Carcinogens*, Progress in Mutation Research, Vol. 5, Elsevier, Amsterdam, pp. 639-650.
- 27 Simmons, J.E., DeMarini, D.M. and Berman, E. (1988) Lethality and hepatotoxicity of complex waste mixtures. *Environ. Res.* 46, 74-85.
- 28 Gupta, R.C., Reddy, M.V. and Randerath, L. (1982) <sup>32</sup>P-Postlabelling analysis of non-radioactive aromatic carcinogen-DNA adducts. *Carcinogenesis* 3, 1081-1092.



- 29 Gallagher, J.E., Robertson, I.G.C., Jackson, M.A., Dietrick, A.M., Ball, L.M. and Lewtas, J. (1988) <sup>32</sup>P-Postlabeling analysis of DNA adducts of two nitrated polycyclic aromatic hydrocarbons in rabbit tracheal epithelial cells. In: C.M. King, L.J. Romano, and D. Schuetzle (Eds.), *Carcinogenic and Mutagenic Responses to Aromatic Amines and Nitroarenes*, Elsevier, Amsterdam, pp. 277-281.
- 30 Elespuru, R.K. (1984) Induction of bacteriophage lambda by DNA-interacting chemicals. In: F.J. de Serres (Ed.), *Chemical Mutagens: Principles and Methods for Their Detection*, Vol. 9, Plenum, New York, pp. 213-231.
- 31 Elespuru, R.K. (1987) Inducible response to DNA damage in bacteria and mammalian cells. *Environ. Mol. Mutagen.* 10, 97-116.
- 32 Hofnung, M. and Quillardet P. (1986) Recent developments in bacterial short-term tests for the detection of genotoxic agents. *Mutagenesis* 1, 319-330.
- 33 Ashby, J. de Serres, F.J., Draper, M., Ishidate, M., Margolin, B.H., Matter, B.E. and Shelby, M.D. (1985) Evaluation of Short-Term Tests for Carcinogens, *Progress in Mutation Research*, Vol. 5, Elsevier, Amsterdam.
- 34 Tennant, R.W., Margolin, B.H., Shelby, M.D., Zeiger, E., Haseman, J.K., Spalding, J., Caspary, W., Resnick, M., Stasiewicz, S., Anderson, B. and Minor, R. (1987) Prediction of chemical carcinogenicity in rodents from *in vitro* genetic toxicity assays. *Science* 236, 933-941.
- 35 Simmons, J.E., DeMarini, D.M. and Berman, E. (1988) *In vivo* assessment of complex wastes: Lethality, hepatotoxicity, and mutagenicity. In: M.M. Varma, and J.H. Johnson (Eds.), *Hazardous and Industrial Waste, Proceedings of the Twentieth Mid-Atlantic Industrial Wastewater and Hazardous Material Conference*, pp. 444-464.
- 36 Greer, L.E. (1984) Definition of hazardous waste. *Hazard. Waste* 1, 309-322.
- 37 Federal Register (1983) Notification requirements; reportable quantity adjustments, Vol. 48, No. 102, 23552-23602.
- 38 Federal Register (1984) Hazardous waste management systems, Vol. 49, No. 32, February 15, 5854-5859.
- 39 Federal Register (1984) Proposed deadlines for exposure assessment, Vol. 49, No. 227, November 23, 46304-46312.
- 40 Guiney, P.D. (1985) Use of predictive toxicology methods to estimate relative risk of complex chemical waste mixtures. *Hazard. Waste Hazard. Matr.* 2, 177-189.

## MECHANISM OF THE LETHAL INTERACTION OF CHLORDECONE AND CCl<sub>4</sub> AT NONTOXIC DOSES

Harihara M. Mehendale

*Department of Pharmacology and Toxicology, University of Mississippi Medical Center,*

*2500 North State Street, Jackson, MS 39216*

### SUMMARY

There is a significant interest in the possibility of unusual toxicity due to interaction of toxic chemicals upon environmental or occupational exposures even though such exposures may involve levels ordinarily considered harmless individually. While many laboratory and experimental models exist for such interactions, progress in this area of toxicology has suffered for want of a model where the two interactants are individually nontoxic. We developed such a model where prior exposure to nontoxic levels of the pesticide Kepone® (chlordecone) results in a 67-fold amplification of carbon tetrachloride (CCl<sub>4</sub>) lethality in experimental animals. The mechanism(s) by which chlordecone amplifies the hepatotoxicity of halomethanes such as CCl<sub>4</sub>, chloroform (CHCl<sub>3</sub>), and bromotrichloromethane (BrCCl<sub>3</sub>) has been a subject of intense study. The biological effects of this interaction include extensive hepatotoxicity characterized by histopathological alterations, hepatic dysfunction, and perturbation of related biochemical parameters. Close structural analogs of chlordecone such as mirex and photomirex do not share the propensity of chlordecone to potentiate halomethane toxicity. Mechanisms such as induction of microsomal cytochrome P-450 by chlordecone and greater lipid peroxidation are inadequate to explain the remarkably powerful potentiation of toxicity and lethality. Time-course studies in which liver tissue was examined 1 to 36 h after CCl<sub>4</sub> administration were conducted. While animals receiving a normally nontoxic dose of CCl<sub>4</sub> alone show limited hepatocellular necrosis by 6 h, proceeding to greater injury after 12 h, a recovery phase ensues as revealed by the greatly increased number of mitotic figures. Such regeneration and hepatic tissue repair processes are totally suppressed in animals exposed to chlordecone prior to CCl<sub>4</sub>. Thus, the arrested hepatocellular repair and renovation play a key role in the potentiation of CCl<sub>4</sub> liver injury by chlordecone.

These findings have allowed us to propose a novel hypothesis for the mechanism of chlordecone amplification of halomethane toxicity and lethality. While limited injury is initiated by the low dose of CCl<sub>4</sub> by bioactivation followed by lipid peroxidation, this normally recoverable injury permissively progresses due to arrested hepatocellular regeneration and tissue repair processes. Recent studies designed to test this hypothesis have provided additional supporting evidence. Hepatocellular regeneration stimulated by partial hepatectomy was unaffected by 10-ppm dietary

chlordecone, while these animals were protected from the hepatotoxic and lethal actions of  $\text{CCl}_4$  if administered at the time of maximal hepatocellular regeneration. The protection was abolished when  $\text{CCl}_4$  was administered upon cessation of hepatocellular regeneration.

## INTRODUCTION

The propensity and the specificity with which chlordecone (Figure 1) amplifies the hepatotoxic action of halomethane solvents has been well established [1-22]. Prior exposure to chlordecone results in an approximately tenfold potentiation of  $\text{CHCl}_3$  [17] and even greater potentiation of  $\text{CCl}_4$  [1-7] hepatotoxicity. Exposure of male Swiss-Webster mice to a single oral dose of chlordecone (50 mg/kg) potentiates the hepatotoxicity of  $\text{CHCl}_3$  as measured by serum transaminases and by histopathologic examination of the liver tissue for hepatocellular necrosis [17]. Recent studies [22] indicate that in addition to the hepatotoxic effects of  $\text{CHCl}_3$ , this interaction leads to a fourfold increase in lethality by dietary exposure of mice to a much lower level of chlordecone (10 ppm for 15 days). Neither mirex (10 ppm) nor phenobarbital (225 ppm) in a similar dietary protocol increased the hepatotoxic or lethal effects of  $\text{CHCl}_3$  [22].

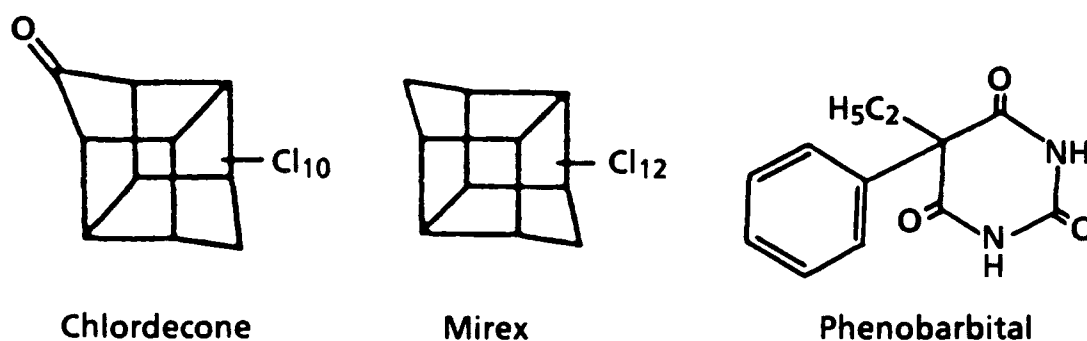


Figure 1. Structures of Chlordecone, Mirex, and Phenobarbital.

The same dietary exposure of rats to 10 ppm chlordecone (total dose, roughly 10 mg/kg) results in a greatly potentiated hepatotoxic response to  $\text{CCl}_4$  as determined by functional, biochemical, and histopathologic parameters [1-16].  $\text{CCl}_4$  lethality is increased 67-fold by chlordecone in male rats [5] and 25-fold in female rats [6]. The specificity of chlordecone in potentiating halomethane hepatotoxicity was illustrated by the ineffectiveness of mirex [3] or photomirex [2]. Furthermore, exposure to phenobarbital at 50 times greater levels (on a molar basis) caused less than 50% of the potentiation of  $\text{CCl}_4$  hepatotoxicity caused by chlordecone [3], and the lethality was increased only by a statistically insignificant 1.6-fold [5]. Hepatotoxic and lethal effects of  $\text{BrCCl}_3$  also are potentiated by chlordecone [7, 8], while the toxicities of bromoform ( $\text{CHBr}_3$ ) and tetrabromomethane ( $\text{CBr}_4$ ) are unaffected [9, 10]. Hepatotoxicity of neither trichloroethylene nor bromobenzene is potentiated by 10 ppm chlordecone [11].

The mechanism of this highly powerful and unusual interaction with halomethanes has eluded many investigations [1-28]. Because chlordecone potentiates the hepatotoxic and lethal effects of several halomethanes at individually nontoxic or subtoxic levels, the interaction represents a very attractive model for biological effects of toxic chemical interactions of environmental chemicals at levels in the neighborhood of environmental significance, and the mechanism underlying this highly unusual interaction offers a continuing challenge for investigation. An experimental evaluation of whether mechanisms widely held accountable for the potentiation of  $\text{CCl}_4$  hepatotoxicity can account for the chlordecone +  $\text{CCl}_4$  interaction will follow. Recent efforts have led to the discovery of a novel mechanism for this interaction.

### ***Mechanisms of Halomethane Hepatotoxicity***

The mechanism of  $\text{CCl}_4$ -induced hepatotoxicity has been extensively studied [29-32]. Because the basic mechanism underlying the toxicology of  $\text{CCl}_4$  is central to the consideration of how its toxicity might be modified by other chemicals, it would be worthwhile to outline the prevailing concepts concerning the hepatotoxicity of  $\text{CCl}_4$ . Excellent reviews have appeared on this topic [29-32]. The leading theory for the mechanism of cellular damage caused by  $\text{CCl}_4$  states that the compound is bioactivated by cytochrome P-450-mediated reactions to  $\cdot\text{CCl}_3$  free-radical [29-35], which is further converted to peroxy radical ( $\text{CCl}_3\text{O}\cdot$ ) [31,36,37]. There is evidence for covalent binding of  $\text{CCl}_4$  upon bioactivation [29-32]. The  $\text{CCl}_3\text{O}\cdot$  radical also is thought to decompose to phosgene and electrophilic chlorine, which can react with other micromolecules. The free-radicals  $\cdot\text{CCl}_3$  and  $\text{CCl}_3\text{O}\cdot$  readily react with polyunsaturated fatty acids of the endoplasmic reticulum and other hepatocellular membranes to initiate the formation of organic lipid peroxides. In the presence of cellular  $\text{O}_2$ , organic peroxy radicals produced, in turn, can react with other polyunsaturated fatty acids to perpetuate a series of self-propagating chain reactions, a process commonly referred to as propagation of lipid peroxidation [29]. The bioactivation of  $\text{CCl}_4$  and initiation of the self-propagating lipid peroxidation, working in tandem, destroy the cellular membranes leading to cell death. The principal hepatic lesion is characterized by centrilobular necrosis [38], with the extent of injury depending upon the dose. Demonstration of the metabolism of  $\text{CCl}_4$  to  $\text{CHCl}_3$  and to  $\text{CO}_2$  [39, 40], and covalent binding of  $\text{CCl}_4$  to liver protein and lipid [41] provide experimental support to the bioactivation of  $\text{CCl}_4$  [31-44].

Small doses of  $\text{CCl}_4$  are known to protect against a subsequently administered large dose of  $\text{CCl}_4$  [45, 46]. Several lines of evidence have accumulated [45-47] to persuade one to believe that the mechanism of this "autoprotection" is related to the destruction of liver microsomal cytochrome P-450 by the initial protecting dose of  $\text{CCl}_4$ . Reports [48,49] demonstrating the destruction of a specific form of cytochrome P-450 provide additional support for  $\cdot\text{CCl}_3$  free-radical-mediated destruction of cytochrome P-450. A direct demonstration of  $\cdot\text{CCl}_3$  radical has been claimed using spin trapping techniques [48,50,51], although these studies have been criticized [52] and what free-radical is being trapped is debated [51,52]. The precise events leading to the destruction of cytochrome P-

450 by  $\text{CCl}_4$  are not clear [29-32]. One view holds that the  $\cdot\text{CCl}_3$  free-radical directly interacts with the endoplasmic reticulum and destroys the cytochrome P-450 [49,53], while the other view [54] holds that lipid peroxidation initiated by the  $\text{CCl}_3$  free-radical results in the destruction of cytochrome P-450. There is evidence that the lipid peroxidative process initiated by the  $\cdot\text{CCl}_3$  radicals results in the release of 4-hydroxynonenol [55], which has been demonstrated to inhibit cytochrome P-450-mediated mixed function oxidase (MFO) activity [56]. The demonstration that phosgene is a metabolite of  $\text{CCl}_4$  [44,57] has raised the possibility that this reactive metabolite also may be involved in the destruction of cytochrome P-450.

Hepatotoxicity of  $\text{BrCCl}_3$ , a brominated analog of  $\text{CCl}_4$ , is also, by virtue of its metabolism to the same  $\cdot\text{CCl}_3$  radical [58-60], formed from  $\text{CCl}_4$ . Much greater toxicity of this compound [34] in comparison to  $\text{CCl}_4$  has been attributed to the relative ease with which the C-Br bond can be cleaved. A clear inverse relationship exists between the bond dissociation energy of these series of halomethanes ( $\text{BrCCl}_3$ ,  $\text{CCl}_4$ , fluorotrichloromethane ( $\text{FCCl}_3$ ),  $\text{CHCl}_3$ ) and their potency to initiate free-radical reactions [29,32] to produce lipid peroxidation and to produce liver necrosis.

With regard to chloroform, the results of several investigations suggest that phosgene, a reactive metabolite of  $\text{CHCl}_3$  is responsible for its hepatotoxic [61,62], nephrotoxic [63], and possibly its carcinogenic [61] effects. Hepatotoxic effects are due to phosgene-mediated cellular GSH depletion or due to increased amounts of covalent binding to hepatocellular macromolecules [61,64,65]. Although like  $\text{CCl}_4$ ,  $\text{CHCl}_3$  needs to be metabolized in order to exert its full necrogenic potential, unlike  $\text{CCl}_4$ , lipid peroxidation is not believed to be involved in the hepatocellular necrosis. A second important distinction is that unlike  $\text{CCl}_4$ , metabolism of  $\text{CHCl}_3$  to a free-radical form has not been associated with its necrogenic action [61].

#### ***Mechanism of Potentiation of Halomethane Hepatotoxicity***

The capacity to enhance  $\text{CCl}_4$  toxicity and hepatic necrosis has been attributed to a variety of chemicals: phenobarbital [49,66-68], aliphatic alcohols [69,70], ketones [71,72], DDT [73], and polychlorinated biphenyls [74]. 3-Methylcholanthrene was shown to protect [75] while 3, 4-benzo[*a*]pyrene was similar to phenobarbital in enhancing  $\text{CCl}_4$  hepatotoxicity [76]. Treatment either with cysteamine, cysteine [77], or SKF-525A [77,78] affords protection against  $\text{CCl}_4$  hepatotoxicity. Most, if not all, experimental conditions that potentiate the toxicity of  $\text{CCl}_4$  correlate with increased hepatic microsomal cytochrome P-450 content and with accordingly increased bioactivation of  $\text{CCl}_4$  in the liver. Hepatocellular injury is increased as a result of the enhanced lipid peroxidation as a consequence of the enhanced production of free-radical forms of  $\text{CCl}_4$  metabolites.

Hepatotoxicity of  $\text{BrCCl}_3$  also is known to be potentiated [59] by agents known to induce drug-metabolizing enzymes of the liver. Hepatotoxicity of other halomethanes related to  $\text{CCl}_4$  also is

potentiated by other chemicals. Hepato- and nephrotoxicity of chloroform is potentiated by aliphatic alcohols [79,80], polybrominated biphenyls [81], ketones [80], and phenobarbital [61].

The prevailing widely accepted theory for the mechanism of xenobiotic-induced enhancement of cellular damage caused by  $\text{CCl}_4$  is that its bioactivation to  $\cdot\text{CCl}_3$  and  $\text{CCl}_3\text{O}\cdot$  free-radical [29-32] is increased. There is evidence for increased covalent binding of  $\text{CCl}_4$  to liver tissue upon bioactivation. Increased production of  $\cdot\text{CCl}_3$  or  $\text{CCl}_3\text{O}\cdot$  radicals leads to increased lipid peroxidation, culminating in increased liver injury.

#### ***Potentialiation of Halomethane Hepatotoxicity by Chlordecone***

It initially was observed that the administration of a small dose of  $\text{CCl}_4$  (100  $\mu\text{L}/\text{kg}$ , ip) to rats maintained on a normal diet did not result in any significant liver damage [1]. However, rats maintained on a diet containing 10 ppm chlordecone for 15 days exhibited remarkably potentiated hepatotoxicity [1]. In subsequent work, it was apparent that this represented potentiation of  $\text{CCl}_4$  toxicity rather than the toxicity of chlordecone (Table 1). Exposure to 10 ppm chlordecone for 15 days causes no visible and no measurable signs of toxicity. Slightly impaired hepatobiliary function, detectable as compromised biliary excretion of phenolphthalein glucuronide is the only measurable liver dysfunction attributable to the dietary exposure of rats to chlordecone [1,3,7,8] described to date.

The major reasons for referring to this interaction as "potentiation of  $\text{CCl}_4$  hepatotoxicity" are listed in Table 1. Chlordecone toxicity is characterized by tremors and hyperactivity [82,83], which are distinctly different from the signs of  $\text{CCl}_4$  toxicity [84], and the animals receiving the combination show distinct signs of  $\text{CCl}_4$  toxicity. Histopathological examination of livers from chlordecone-treated rats reveals several morphological changes [83-85], but these do not include centrilobular necrosis [85]. Prolonged treatment with chlordecone causes focal lesion (necrobiosis [85]), but this is not present uniformly in all the lobes and cannot be characterized as centrilobular necrosis. Centrilobular necrosis is a characteristic of  $\text{CCl}_4$  hepatotoxicity [29,32,38] and the combination treatment causes extensive centrilobular necrosis [1] accompanied by balloon cells (Table 1). Characteristically, chlordecone causes proliferation of smooth endoplasmic reticulum (SER) accompanied by increased cytochrome P-450 [82,86-90], and treatment with  $\text{CCl}_4$  results in destruction of SER and cytochrome P-450 [16,29,32]. Serum enzymes (e.g., SGPT, SGOT, ICD, and OCT) are not elevated by chlordecone treatment, and these also are not elevated significantly by the low dose of  $\text{CCl}_4$  (100  $\mu\text{L}/\text{kg}$ ) alone. The combination treatment greatly increases these serum enzyme levels [1]. Finally, there are differences in the effects of these two toxic chemicals on hepatobiliary function (Table 1). Chlordecone impairs excretory function but this is accompanied by choleresis [91], while  $\text{CCl}_4$  causes excretory dysfunction accompanied by reduced bile flow [16,32,91]. The combination treatment results in total abrogation of excretory function, accompanied by cholestasis [1-16,32]. Furthermore,

**TABLE 1. TOXICITY CHARACTERISTICS OF CHLORDECONE, CCl<sub>4</sub>, AND CHLORDECONE + CCl<sub>4</sub> COMBINATION**

Parameter of Toxicity	Chlordecone	CCl <sub>4</sub>	CD + CCl <sub>4</sub> Combination <sup>a</sup>
1. Signs	Tremors, hyperactivity	Lethargic and withdrawn	Lethargic and withdrawn
2. Histopathology	None <sup>b</sup>	Centrilobular necrosis	Extensive centrilobular and diffuse necrosis
a. Hepatic necrosis			
b. Other changes	No balloon cells Increased smooth (ER)	Balloon cells Decreased smooth ER	More balloon cells Decreased smooth ER
3. Hepatic Cyt. P-450	No change	Increased	Greatly increased
4. Serum enzymes	No change	Increased	Greatly increased
5. Hepatobiliary function	Impaired excretion and bile flow	Impaired excretion and bile flow	Impaired excretion and bile flow
6. LD <sub>50</sub>	132 mg/kg (2 to 7 days) <sup>c</sup>	2.8 mL/kg (2 days) <sup>d</sup>	0.042 mL/kg (2 days) <sup>d</sup>

<sup>a</sup> The combination treatment implies a 15-day dietary exposure to 10 ppm followed by a single ip dose of 100  $\mu$ L CCl<sub>4</sub>/kg. Toxicity characteristics listed for chlordecone and CCl<sub>4</sub> alone or after the administration of either at a toxic dose.

<sup>b</sup> Prolonged exposure to chlordecone has been reported to cause occasional focal hepatocellular necrosis [85]. Occasional focal necrotic areas (necrobiosis) were found in livers after three months of dietary exposure to 25 ppm and, similarly, focal necrosis was observed in the carcinogenicity bioassay protocols after 21 months of exposure [85]. Uniform centrilobular necrotic lesions such as seen with CCl<sub>4</sub> have not been reported at any dose of chlordecone in acute, subchronic, or chronic studies.

<sup>c</sup> From Larson et al. 1979 [83].

<sup>d</sup> From Klingensmith and Mehendale 1982 [5].  
Reproduced from Mehendale 1984 [16] with permission.

simultaneous treatment of chlordecone and CCl<sub>4</sub> does not result in potentiated toxicity [12]. All of these signs of toxicity and other histological, biochemical, or functional parameters suggest that it is CCl<sub>4</sub> toxicity that is potentiated by the combined treatment. Potentiation of CCl<sub>4</sub> toxicity by chlordecone is not limited to the disruption of hepatic function, but also leads to lethality in male [5] and female rats [6]. The LD<sub>50</sub> of CCl<sub>4</sub> in rats exposed to chlordecone in males [5] and females is 42 and 48  $\mu$ L/kg, respectively, despite over twofold greater sensitivity of female rats for CCl<sub>4</sub> [5,6], indicating that the estrogenic property of chlordecone is not involved in this phenomenon.

Studies indicate that the marked potentiation could not be readily explained by increased lipid peroxidation [13,26,52], depletion of hepatic GSH, or by increased covalent binding of <sup>14</sup>CCl<sub>4</sub>-derived radiolabel to the liver [13,26,52]. These studies were conducted 1 and 6 h after CCl<sub>4</sub> administration to control and chlordecone-treated rats [13,16,26,32,52].

The marked potentiation of CCl<sub>4</sub> toxicity by chlordecone does not lend itself to be accounted for by increased hepatic microsomal cytochrome P-450 content and associated parameters, because

mirex and photomirex, both being more powerful inducing agents than chlordecone, do not potentiate  $\text{CCl}_4$  toxicity significantly [17,87-91,92]. Exposure to phenobarbital (250 ppm in diet) at 50 times equimolar level of chlordecone caused significant elevation of MFO parameters, and resulted in potentiation of  $\text{CCl}_4$  lethality only by 1.6 fold, which is 40 times less than that increased by chlordecone [5]. The destruction of hepatic microsomal cytochrome P-450 and related parameters in rats treated with phenobarbital +  $\text{CCl}_4$  or chlordecone +  $\text{CCl}_4$  were similar [27], indicating that such indices cannot be used as reliable indicators of  $\text{CCl}_4$  bioactivation [27,93].

### ***Specificity of Potentiation***

In view of the remarkable capacity for chlordecone to potentiate halomethane hepatotoxicity and lethality ( $\text{CCl}_4$ ,  $\text{CHCl}_3$ ,  $\text{BrCCl}_3$ , etc.), it was of interest to examine if chlordecone could potentiate the toxicity of structurally and mechanistically dissimilar chemicals [11]. Chlordecone pretreatment was compared with mirex and phenobarbital pretreatments using 1,1,2-trichloroethylene (TCE) and bromobenzene (BB) as two hepatotoxins structurally and mechanistically dissimilar to  $\text{CCl}_4$ . The powerful nature of chlordecone +  $\text{CCl}_4$  interaction was not observed either with chlordecone + TCE or chlordecone + BB combinations [11]. At much higher doses, chlordecone and mirex are reported to potentiate toxicity of acetaminophen [94], but this effect appears to be mediated by the induced microsomal cytochrome P-450 levels similar to the potentiation of  $\text{CCl}_4$  hepatotoxicity by higher doses of photomirex [2]. These observations point to a degree of specificity on the part of chlordecone at nontoxic doses to potentiate halomethane toxicity. Although chlordecone is not totally specific to  $\text{CCl}_4$ , because  $\text{CHCl}_3$  and  $\text{BrCCl}_3$  toxicity also is potentiated, some degree of specificity with respect to which halomethane toxicity is potentiated exists, as evidenced by the lack of potentiation of  $\text{HCCl}_3$  and  $\text{CBr}_4$  toxicity [9, 10].

In additional experiments, it was established that one single oral administration of chlordecone dose equivalent to the total dose in dietary protocol did indeed cause potentiation of  $\text{CCl}_4$  toxicity [12]. Potentiation of  $\text{CCl}_4$  hepatotoxicity could be demonstrated by the sixth hour and was maximal between 48 to 72 h after chlordecone administration. However, the degree of potentiation was much less than the dietary chlordecone pretreatment. Simultaneous administration of chlordecone and  $\text{CCl}_4$  did not result in potentiated toxicity [12].

### **POSSIBLE MECHANISMS**

A number of mechanisms (Table 2) can be considered to account for the remarkable amplification of haloalkane toxicity by chlordecone. Increased bioactivation of  $\text{CCl}_4$  and increased lipid peroxidation are the foremost (Table 2) in view of the wide acceptance of these mechanisms with respect to phenobarbital, alcohol, ketone, and other xenobiotic-induced enhancement of  $\text{CCl}_4$



toxicity [24,25,29-53]. These mechanisms are discussed with regard to the experimental evidence for or against these mechanisms.

**TABLE 2. POSSIBLE MECHANISMS FOR CHLORDECONE AMPLIFICATION OF CCl<sub>4</sub> TOXICITY**

- 
1. Enhanced bioactivation of CCl<sub>4</sub>
  2. Increased lipid peroxidation
  3. Estrogenic property of chlordecone
  4. Increased Ca<sup>2+</sup> accumulation
  5. Suppressed hepatocellular regeneration
- 

### **Enhanced Bioactivation**

The widely accepted mechanism for the potentiation of CCl<sub>4</sub> hepatotoxicity by xenobiotics is the enhancement of CCl<sub>4</sub> bioactivation [34-37], followed by increased lipid peroxidation [29-32]. A number of investigations [5,13,16,26-28] were carried out to examine if enhanced bioactivation of CCl<sub>4</sub> in chlordecone-treated animals might offer a satisfactory explanation for the highly powerful potentiation of its toxicity. Neither the initial *in vivo* <sup>14</sup>CCl<sub>4</sub> metabolism nor the covalent binding 1h after the administration of <sup>14</sup>CCl<sub>4</sub> were significantly altered by pre-exposure to chlordecone, particularly in comparison to pre-exposure to phenobarbital [28]. Studies designed to examine whether enhanced *in vitro* metabolism of <sup>14</sup>CCl<sub>4</sub> could be demonstrated and whether differences among chlordecone, phenobarbital, and mirex pretreatments correspond with the associated alterations (or lack thereof) in CCl<sub>4</sub> toxicities indicated no significant enhancement in CCl<sub>4</sub> metabolism nor a significant change in the pathway of its metabolism by hepatic microsomes derived from chlordecone-treated rats [13].

Because chlordecone is an inducer of hepatic microsomal cytochrome P-450, and individual isozyme(s) responsible for CCl<sub>4</sub> metabolism may be increased [16], one must consider the possibility that small changes in pools of individual isozymes may yield dramatic changes in the bioactivation of CCl<sub>4</sub>. The extent of metabolism of <sup>14</sup>CCl<sub>4</sub> in intact animals pretreated with chlordecone would be indicative of whether such changes in P-450 isozymes have occurred. To follow this analogy further, comparison of these findings from mirex-treated and phenobarbital-treated animals *in vivo* provides a convenient way of verifying the overall interpretations from the results of *in vivo* <sup>14</sup>CCl<sub>4</sub> metabolism.

The *in vivo* metabolism of CCl<sub>4</sub> in rats pretreated with either chlordecone, mirex, or phenobarbital was compared by measuring the hepatic content of <sup>14</sup>CCl<sub>4</sub>, the expiration of <sup>14</sup>CCl<sub>4</sub>, expiration of <sup>14</sup>CCl<sub>4</sub>-derived <sup>14</sup>CO<sub>2</sub>, and lipid peroxidation [26]. Expiration of <sup>14</sup>CO<sub>2</sub> measured during

the 6 h after  $^{14}\text{CCl}_4$  administration was increased in animals pretreated with phenobarbital or chlordecone. However, the serum transaminases (ALT, AST) were elevated significantly at 6 h only in animals pretreated with chlordecone. Mirex did not affect  $^{14}\text{CO}_2$  production. The radiolabel present in the liver at 6 h showed no difference in hepatic content of free  $^{14}\text{CCl}_4$  among the groups, but the covalently bound label present in the lipid fractions of the livers pretreated with phenobarbital was elevated in comparison to chlordecone and mirex treatments. These studies indicate that a single oral administration of chlordecone (10 mg/kg) 24 h prior to  $\text{CCl}_4$  administration (100  $\mu\text{L}/\text{kg}$ ) enhances the oxidative metabolism of  $\text{CCl}_4$  but to a lesser extent than phenobarbital (80 mg/kg, ip, twice), which is in inverse relationship to the potentiation of the hepatotoxic and lethal effects of  $\text{CCl}_4$  associated with these pretreatments [26].

The possibility that  $\text{CCl}_4$  metabolism is occurring via an alternate pathway in chlordecone-treated animals has been considered in *in vitro* studies with hepatic microsomes isolated from rats pretreated with chlordecone, mirex, or phenobarbital [13]. Phosgene formation from  $^{14}\text{CCl}_4$  was not increased, indicating  $\text{CCl}_4$  metabolism had not been increased via this alternate pathway. Because phosgene could be formed either directly from  $\text{CCl}_4$  or indirectly from  $\text{CHCl}_3$ , these findings also argue against the increased  $\text{CHCl}_3$  formation as a potentiation mechanism.

Several other lines of evidence point to mechanism(s) other than increased bioactivation as the critical underlying event. Exposure of rats to 250 ppm phenobarbital in the diet (50 times chlordecone on a molar basis) for 15 days, which results in doubled hepatic cytochrome P-450 levels, causes much less potentiation of  $\text{CCl}_4$  hepatotoxicity [3] and even less (40 times less than chlordecone treatment) of an increase in lethality [5]. Mirex and photomirex, the two closely related structural analogs of chlordecone are more powerful inducers of the hepatic mixed function oxygenase system [3,17,87-90,92] but are weaker potentiators of  $\text{CCl}_4$  hepatotoxicity [1,6,16]. The third line of evidence comes from the autoprotection experiments [95], where prior repeated exposure to smaller doses of  $\text{CCl}_4$ , a treatment known to decrease hepatic microsomal cytochrome P-450, fails to protect the animals from the  $\text{CCl}_4$  toxicity of the chlordecone +  $\text{CCl}_4$  combination.

Another line of argument against the increased bioactivation of  $\text{CCl}_4$  as the critical event for chlordecone potentiation of  $\text{CCl}_4$  toxicity comes from the *in vivo*  $^{14}\text{CCl}_4$  metabolism experiments [26]. It is well established that less than 1% of the administered  $\text{CCl}_4$  ever needs to be metabolized [39,40] in order to realize the necrogenic potential of  $\text{CCl}_4$  [31]. *In vivo* studies employing a small dose of  $\text{CCl}_4$  (100  $\mu\text{L}/\text{kg}$ ) indicate that less than 1% of  $\text{CCl}_4$  is metabolized in 6 h, and approximately 75% of the administered dose of  $\text{CCl}_4$  is exhaled by that time. Similar findings were reported by other investigators [39,40] employing higher doses of  $\text{CCl}_4$ . If one assumes that 1% of  $\text{CCl}_4$  is ever metabolized in normal animals [26,39,40] and in chlordecone-treated animals [26] at equitoxic doses (2.8 mL/kg and 0.042 mL/kg, respectively, being  $\text{LD}_{50}$  doses) [5], metabolism of 28  $\mu\text{L}$  of  $\text{CCl}_4$  would be

equivalent to the metabolism of 0.42  $\mu\text{L}$  of  $\text{CCl}_4$  in chlordecone-treated animals on a kilogram-body weight basis (Table 3). Even if one assumes a tenfold increase in the bioactivation of  $\text{CCl}_4$  in chlordecone-treated rats, total  $\text{CCl}_4$  metabolized is still one seventh of that in the normal rat. On the other hand, a similar consideration of the metabolism of  $\text{CCl}_4$  in phenobarbital-treated rats, wherein  $\text{CCl}_4$  metabolism was tripled (based on  $^{14}\text{CO}_2$  production from  $^{14}\text{CCl}_4$ ) [26], is that the amount of  $\text{CCl}_4$  metabolized can be estimated to be 51  $\mu\text{L}/\text{kg}$  body weight. If increased metabolism is the mechanism underlying the potentiated toxicity, one would predict a 1.8-fold potentiation (28 vs. 51  $\mu\text{L}/\text{kg}$ ) of  $\text{CCl}_4$  toxicity, which is in general agreement with the observed 1.6-fold increase in toxicity [5].

**TABLE 3. COMPARISON OF ESTIMATED  $\text{CCl}_4$  BIOACTIVATION AT EQUITOXIC DOSES IN NORMAL AND CHLORDECONE TREATED-RATS<sup>a</sup>**

Parameter	Normal	Phenobarbital-pretreated rat	Chlordecone-pretreated rat ( $\mu\text{L}/\text{kg}$ )
$\text{LD}_{50}$ of $\text{CCl}_4$	2.8 mL/kg	1.7 mL/kg	42
Estimated $\text{CCl}_4$ bioactivation:			
assuming 1%	28 $\mu\text{L}/\text{kg}$	17 $\mu\text{L}/\text{kg}$	0.42
assuming a threefold	—	51 $\mu\text{L}/\text{kg}$	1.26
assuming a tenfold	—	170 $\mu\text{L}/\text{kg}$	4.20
increase after phenobarbital or chlordecone exposure			

- <sup>a</sup> Data adopted from Klingensmith and Mehendale [5]. Table shows that even if  $\text{CCl}_4$  metabolism after exposure to chlordecone is increased tenfold, it is unlikely to be a satisfactory mechanism for the highly potentiated  $\text{CCl}_4$  toxicity. In contrast, a threefold increase in  $\text{CCl}_4$  bioactivation after exposure to phenobarbital might be expected to be reflected in a 1.8-fold increase in  $\text{LD}_{50}$  of  $\text{CCl}_4$  and it was associated with a 1.6-fold increase in  $\text{LD}_{50}$  [5]. Reproduced from Mehendale (In Press) [32] with permission.

Because the bioactivation of  $\text{CCl}_4$  has been associated with the destruction of microsomal cytochrome P-450, the latter has been considered to be indicative of the extent of the bioactivation of  $\text{CCl}_4$  [93]. The phenomenon of "autoprotection" of  $\text{CCl}_4$ , wherein low doses of  $\text{CCl}_4$  administered prior to a larger, ordinarily toxic dose afford protection, provides additional evidence for the association between bioactivation of  $\text{CCl}_4$  and destruction of microsomal P-450. Quantitative analysis of the cytochrome P-450 destroyed in liver microsomes isolated from rats treated with  $\text{CCl}_4$  with or without prior treatment with chlordecone, mirex, or phenobarbital indicates that this is not a reliable parameter of  $\text{CCl}_4$  bioactivation [26, 27]. While there were significant differences between mirex and chlordecone-treated rats, the differences were trivial between chlordecone and phenobarbital-treated rats [27], observations not in support of the known toxicities associated with these treatments.

While chlordecone treatment does increase the metabolism of  $\text{CCl}_4$  *in vivo* modestly, this increase in metabolism by itself is unlikely to satisfactorily explain the highly amplified hepatotoxic and lethal effects of  $\text{CCl}_4$  associated with prior exposure to a nontoxic dose of chlordecone. However, because  $\text{CCl}_4$  toxicity requires the bioactivation of the parent compound, it would be logical to assume a role for  $\text{CCl}_4$  metabolism in the initiation of toxicity in chlordecone-treated rats. These arguments suggest the involvement of other factors in addition to the modest enhancement of  $\text{CCl}_4$  metabolism as underlying mechanisms in this unusually powerful amplification of toxicity.

Chlordecone enhancement of  $\text{CHCl}_3$  toxicity also has been demonstrated [17-23]. Enhanced biotransformation of  $\text{CHCl}_3$  as the probable primary mechanism responsible for the potentiation of  $\text{CHCl}_3$ -induced liver damage following chlordecone pretreatment has been studied [20,21]. A general temporal correlation was found between the biotransformation rate measured as microsomal  $^{14}\text{CHCl}_3$ -derived  $^{14}\text{C}$ -binding, chlordecone content, and the severity of liver injury. The *in vivo* macromolecular distribution of  $^{14}\text{CHCl}_3$ -derived radiolabel in rats receiving chlordecone followed by 0.5 mL  $\text{CHCl}_3/\text{kg}$  and those receiving only a high dosage (1 mL/kg) of  $\text{CHCl}_3$  alone are different, despite the similar rate of biotransformation [20]. These investigations can be summarized by stating that enhanced metabolism per se is unlikely to offer a satisfactory explanation of the chlordecone potentiation of  $\text{CHCl}_3$  toxicity. It would appear that other factors are likely involved in the potentiated response to  $\text{CHCl}_3$  by prior exposure to chlordecone [21].

A recent study [22] has shown that while  $\text{CHCl}_3$  hepatotoxicity and lethality is potentiated fourfold by dietary exposure to 10 ppm chlordecone, neither mirex (10 ppm) nor 50-times greater levels of phenobarbital increased either parameters of toxicity.

#### ***Increased Lipid Peroxidation***

Because increased bioactivation of  $\text{CCl}_4$  to  $^{\cdot}\text{CCl}_3$  or  $\text{CCl}_3\text{O}^{\cdot}_2$  would be expected to result in increased lipid peroxidation, this mechanism is the next most probable candidate for the chlordecone potentiation of  $\text{CCl}_4$  hepatotoxicity (Table 2 [16]). This possibility was considered in several studies [13,26-28]. Liver microsomes isolated from chlordecone-treated rats did not exhibit greater lipid peroxidation in the presence of several concentrations of  $\text{CCl}_4$  [28]. Likewise, lipid peroxidation measured *in vivo* as diene conjugation of lipids in the liver tissue 1 h after the administration of  $\text{CCl}_4$  was not enhanced by prior exposure to chlordecone [28]. Nor was melondialdehyde formation significantly increased in liver microsomal incubations during  $\text{CCl}_4$  metabolism [13]. Indeed, phenobarbital pretreatment associated with an approximately 40-fold lesser increase in  $\text{CCl}_4$  toxicity [5] was associated with the greatest increase in lipid peroxidation. Furthermore, lipid peroxidation determined as diene conjugation of hepatic lipids 6 h after the administration of  $\text{CCl}_4$  to animals pre-exposed to chlordecone or phenobarbital was identical [26]. This is in contrast to the

40-fold difference in the potentiation of  $\text{CCl}_4$  toxicity associated with these treatments [5]. Moreover, this level of lipid peroxidation was associated with significant liver injury in the case of chlordecone and with lack of liver injury with phenobarbital, as determined by serum enzyme elevations, histopathology of the liver, and lethality [5,6, 27]. These studies, along with the observations that chlordecone also potentiates the toxicity of  $\text{CHCl}_3$  where lipid peroxidation is not involved, suggest that increased lipid peroxidation is unlikely as a viable mechanism for chlordecone potentiation of halomethane hepatotoxicity by chlordecone.

### ***Estrogenic Property of Chlordecone***

In view of the estrogenic property of chlordecone and its ability to bind to the estrogenic receptors, unlike mirex [96, 97], the possibility that the estrogenic property of chlordecone might be associated with the unusual propensity for the potentiation of  $\text{CCl}_4$  toxicity was considered [6]. Such a possibility would be consistent with a greater sensitivity of female rats to  $\text{CCl}_4$  than male rats upon prior exposure to chlordecone. When tested, however, while chlordecone also potentiated  $\text{CCl}_4$  hepatotoxicity and lethality in female rats, their sensitivity was similar to that of the male rats [6]. Despite the twofold greater sensitivity of the female rats to the toxic and lethal effects of  $\text{CCl}_4$  [6], the  $\text{LD}_{50}$  of  $\text{CCl}_4$  upon exposure to chlordecone was for male 42  $\mu\text{L}/\text{kg}$  [5] and 48  $\mu\text{L}/\text{kg}$  for female rats [6]. In other words, exposure to chlordecone resulted in two effects: (1) potentiated toxicity of  $\text{CCl}_4$ , and (2) abolishment of the normal sex difference in the sensitivity to  $\text{CCl}_4$ .

### ***Increased Calcium Accumulation***

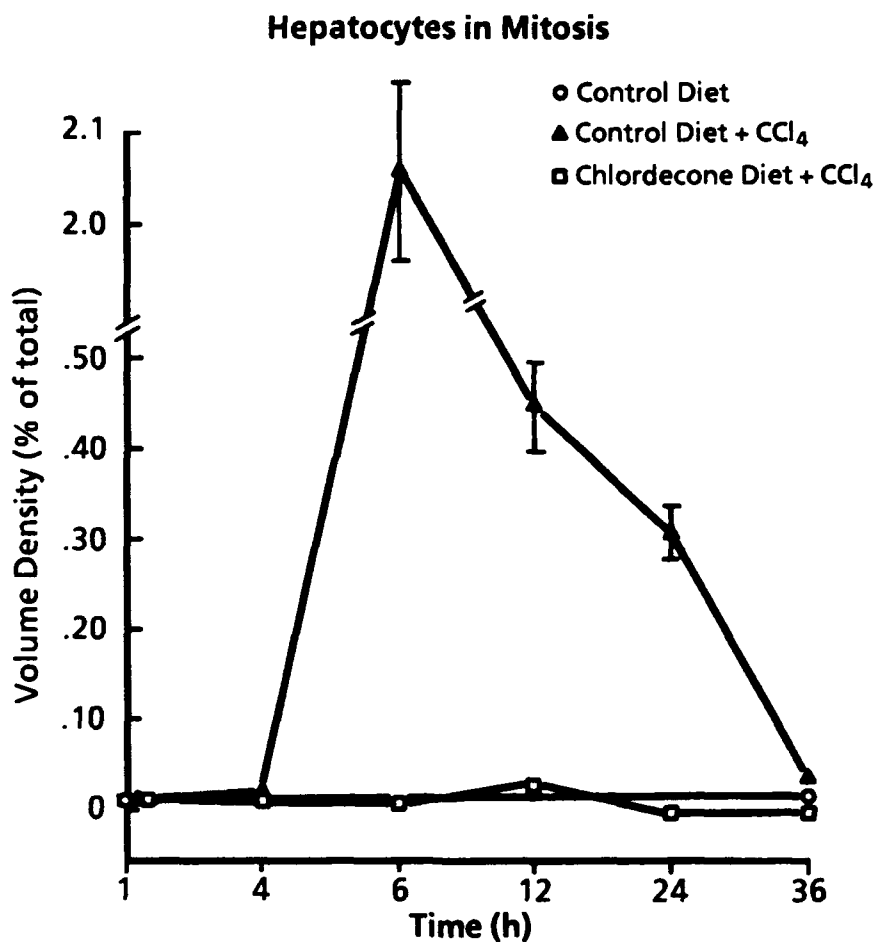
Calcium ions are biologically very active, being capable of considerable disruption of metabolic order [98-100]. Even though all cells in the body are bathed in a fluid rich in calcium (1 mM), intracellular concentrations are much lower (1  $\mu\text{M}$ ) by virtue of energy-dependent cellular extrusion mechanisms and special uptake mechanisms on the part of the intracellular organelles such as mitochondria and SER [101]. When intracellular calcium homeostasis is disrupted, cellular integrity and metabolic checks and balances are thrust into an uncontrollable disarray leading to cellular destruction [100,101]. Carbon tetrachloride has been demonstrated to cause a biphasic increase in intracellular calcium [101]. More recently, interest has focused on the ability of  $\text{CCl}_4$  to disrupt the capacity of hepatic SER to sequester calcium [98]. Recknagel and associates have furthered these observations to demonstrate that  $\text{CCl}_4$ - or  $\text{BrCCl}_3$ -induced *in vitro* lipid peroxidation of hepatic microsomal incubations was accompanied by severe disruption of the ability of SER to sequester calcium ions [102]. Chlordecone has been demonstrated to interfere with calcium uptake in isolated cells, mitochondria, and in brain synaptosomal vesicles [16,103]. The ability of chlordecone to inhibit calcium uptake mechanisms would suggest that the chlordecone +  $\text{CCl}_4$  interaction might be explained partly on the basis of exacerbated disruption of hepatocellular calcium homeostasis.

The influence of  $\text{CCl}_4$  on calcium homeostasis was investigated in animals pretreated with chlordecone [104-107]. As the dose of  $\text{CCl}_4$  was increased from 0 to 200  $\mu\text{L}/\text{kg}$ , total liver calcium levels rose to 12 times the normal levels. Increase in calcium also was observed in the cytosolic fraction, and mitochondrial as well as microsomal sequestration of calcium followed the earlier increase in the cytosolic calcium. It is clear that prior exposure to chlordecone remarkably increases the  $\text{CCl}_4$ -induced perturbation of intracellular calcium. Although in the absence of  $\text{CCl}_4$  treatment, chlordecone alone did not cause any significant changes, and as up to 200  $\mu\text{L}/\text{kg}$  dose of  $\text{CCl}_4$  alone also was ineffective, it is quite clear that exposure to chlordecone does result in sensitization of hepatocytes for exaggerated perturbation of  $\text{CCl}_4$ -induced calcium homeostasis [105]. Perfusion studies with  $^{45}\text{Ca}$  employing isolated perfused livers obtained from treated rats during a time-course after the administration of  $\text{CCl}_4$  indicate that increasing amounts of extracellular  $\text{Ca}^{2+}$  accumulate in the hepatocytes during the progressive phase of hepatotoxicity associated with chlordecone +  $\text{CCl}_4$  combination treatment [107]. Two observations can be made from these results: (1) in animals receiving the combination treatment, there is a progressive increase in intracellular calcium and (2) this increase is greater when animals are exposed to higher concentrations of chlordecone. Because that proportion of total hepatocellular  $\text{Ca}^{2+}$  that is free might be expected to have a direct impact on cellular toxic events, future work will need to examine this aspect of perturbed  $\text{Ca}^{2+}$  homeostasis.

#### ***Arrested Hepatocellular Regeneration***

The time sequence of chlordecone-potentiated  $\text{CCl}_4$  hepatotoxicity was examined in morphological studies [108,109]. Histopathology was assessed by light and electron microscopy at 1, 4, 6, 12, 24 and 36 h after  $\text{CCl}_4$  administration (100  $\mu\text{L}/\text{kg}$ , ip) to control- and chlordecone-treated (10 ppm in diet for 15 days) rats. Serum enzymes were measured as biochemical markers of hepatotoxicity. After the combination treatment, hepatic damage was evident as early as 6 h and this was progressive with time. No sign of recovery was evident. In controls receiving the same dose of  $\text{CCl}_4$  alone, although limited damage could be observed as early as 6 h, which progressed to greater damage at 12 h, hepatocytes and the lobules recovered to normal appearance by 24 h after  $\text{CCl}_4$  administration. A close perusal of the liver sections indicated that hepatocytes were greatly stimulated to divide at 6 h after the administration of a low dose of  $\text{CCl}_4$  alone (Figure 2). This stimulation of cell division was suppressed entirely in animals consuming food contaminated with 10 ppm chlordecone. These studies indicate a strong and progressive amplification of liver injury after the combination treatment, while the liver recovers from the effects of  $\text{CCl}_4$  alone with time. In fact, the lethality experiments indicate that all animals in the chlordecone +  $\text{CCl}_4$  (100  $\mu\text{L}/\text{kg}$ ) combination group die, while those receiving either the same dose of  $\text{CCl}_4$  alone or chlordecone alone survive without any ill effects [5,6].

The above studies [108,109] allowed us to propose a novel mechanism for the highly potentiated toxicity of  $\text{CCl}_4$  by chlordecone. The mechanism simply stated is that the suppression of hepatocellular regeneration and tissue repair in the livers of animals treated with chlordecone +  $\text{CCl}_4$  combination permits the progression of an otherwise limited injury [16]. Extracellular entry of  $\text{Ca}^{2+}$  is associated with these events [16], although it remains to be investigated if excessive hepatocellular  $\text{Ca}^{2+}$  is responsible for arrested hepatocellular regeneration or the mechanism by which excessive  $\text{Ca}^{2+}$  might precipitate such an event. Figure 2 illustrates our working conceptual approaches in this regard.



**Figure 2.** Volume Density of Hepatocytes with Mitotic Figures Is Shown for Control,  $\text{CCl}_4$ , and Chlordecone +  $\text{CCl}_4$  Groups at Various Time Intervals. Chlordecone (100 ppm in the diet for 15 days) and  $\text{CCl}_4$  (100  $\mu\text{L}/\text{kg}$ ) treatments were described earlier. Mitotic index was measured at various times after  $\text{CCl}_4$  administration. Reproduced with permission from reference [109].

### ***Protection by Prestimulated Hepatocellular Regeneration – Partial Hepatectomy Model***

Most recent studies [110,111] were designed to test the hypothesis concerning suppressed hepatocellular regeneration. If suppressed hepatocellular regeneration is, in fact, the reason for the highly amplified liver injury after chlordecone + CCl<sub>4</sub> treatments, then the toxicity of this combination treatment should be decreased in a liver stimulated to regenerate. Partial hepatectomy (PH) is known to stimulate hepatocellular regeneration in a remarkable fashion [112-114], and this experimental model is suitable for testing the hypothesis. The following three initial questions needed to be addressed before employing the partial hepatectomy model.

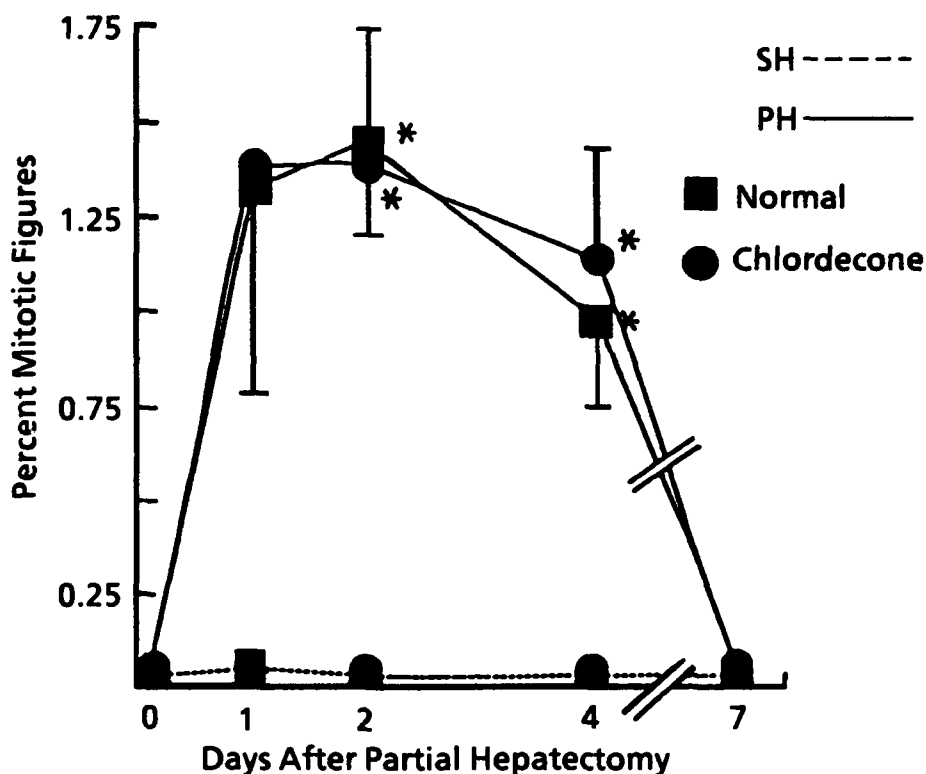
1. Because PH is known to change several biochemical parameters of hepatocytes, is this a valid model to use?
2. Does chlordecone affect hepatocellular regeneration normally seen after PH? This was an important concern because the standardized experimental protocol for the potentiation model [1] requires dietary exposure of rats to 10 ppm chlordecone for 15 days.
3. Does chlordecone itself suppress hepatocellular regeneration in this protocol or is it the chlordecone + CCl<sub>4</sub> combination that is responsible for the suppressed regeneration?

Hepatocellular GSH, GSSG, microsomal protein, and cytochrome P-450, liver-to-body weight ratios, and liver weights were comparable in normal and chlordecone-exposed PH rats at 1, 4, and 7 days after PH. With the exception of a small increase in GSH in chlordecone-treated PH livers at Days 1 and 4, there were no major differences. Microsomal cytochrome P-450 is known to be decreased after PH [113,114], and this was found to be the case, with statistically significant differences between sham-operated (SH) and PH rats occurring only at four days after the surgical manipulation. The 10-ppm chlordecone treatment is known to marginally increase cytochrome P-450 and, therefore, even though PH tended to temper cytochrome P-450 levels downward at 1, 4, and 7 days, the levels were at or higher than in the PH rats not exposed to chlordecone [110].

### ***Does Chlordecone Interfere with Hepatocellular Regeneration?***

Histomorphometric analysis established that hepatocellular regeneration measured as mitotic index after PH was identical in normal and chlordecone-treated rats during a time-course of one through seven days [110]. Regeneration was maximal at one and two days after PH and decreased after four days. Because by seven days the original liver weight is recovered, hepatocellular regeneration also recovers to the normal level of mitotic activity by Day 7. Neither SH nor exposure to chlordecone changed the basal level of minimal mitotic activity. Hepatocellular regeneration was unaltered by the chlordecone treatment (Figure 3). These findings establish that chlordecone treatment alone does not interfere with hepatocyte regeneration and that the PH model could be employed to test the central hypothesis.





**Figure 3. Hepatic Mitotic Indices of Normal and Chlordecone-Treated Rats With and Without Surgical Partial Hepatectomy.** Rats undergoing no surgical manipulation (control), SH, or PH were sacrificed on the designated days following surgery. Values are the mean  $\pm$  SE for N = 3. An asterisk indicates that the values are significantly different from the SH values of the same group ( $p < 0.05$ ). Reproduced with permission from Bell et al. 1988 [110].

#### **Liver Regeneration and Hepatotoxicity of Chlordecone + CCl<sub>4</sub>**

The second phase of this study involved testing the effect of chlordecone + CCl<sub>4</sub> combination treatment in PH animals [110]. Hepatotoxicity of CCl<sub>4</sub> administered 1, 2, 4, or 7 days after the surgical manipulation was measured by way of the serum enzymes (ALT, AST, and ICD) in chlordecone-treated rats as well as in all of the necessary control groups. Liver injury was decreased significantly after PH in comparison to the corresponding SH. The protection by PH was maximal on Day 2, at the time of maximal hepatocyte regeneration, and was minimal on Day 7, at the time of minimal regeneration. These findings show that stimulation of hepatocellular regeneration by PH results in protection against unpotentiated or chlordecone-potentiated CCl<sub>4</sub> hepatotoxicity. Results also show that protection by PH was maximal at the time of maximal hepatocellular regeneration (Days 1 and 2 post-PH) and such protection wanes by Day 7, when hepatocyte regeneration is minimal.

### ***Liver Regeneration and Lethality Associated with Chlordecone + CCl<sub>4</sub>***

Another group of rats was similarly treated one day after surgery for lethality studies [110]. Results clearly showed that PH mitigates the toxicity of chlordecone + CCl<sub>4</sub> combination treatment. In these experiments even though the liver size in the PH animals is less than 4 g (70% of the liver removed during PH, and after 1 day only a very small fraction of that liver weight is regained), in our protocol the full 100 µL CCl<sub>4</sub>/kg dose was administered in PH animals in order to simplify the experiments and maintain our protocol. Despite not adjusting the dose of CCl<sub>4</sub> downward (and, therefore, a larger dose was given to PH rats in comparison to SH or control groups), the results showed significant protection.

Results of the morphometric analysis of liver sections 24 h after CCl<sub>4</sub> dosage reveals that mitotic activity (hepatocyte regeneration) is stimulated significantly after PH in comparison to SH or in animals not surgically manipulated (controls). These observations support our hypothesis concerning suppressed hepatocellular regeneration being the mechanism of chlordecone potentiation of CCl<sub>4</sub> toxicity. The morphometric findings also were revealing in one other aspect. No significant difference was found in the number of necrotic cells between control, SH, and PH groups receiving the chlordecone + CCl<sub>4</sub> combination [110]. This finding is also consistent with our working hypothesis that the highly amplified toxicity of CCl<sub>4</sub> by chlordecone is simply due to the failure of the liver cells to divide and replace the dead or dying cells. Therefore, animals in which livers were stimulated to regenerate are protected, whereas control and SH rats are not protected against the lethal effects of chlordecone + CCl<sub>4</sub> interaction [110].

### ***The Role of Hepatic Microsomal Cytochrome P-450***

The question of decreased microsomal cytochrome P-450 in PH rats and its role in the protection against chlordecone potentiation of CCl<sub>4</sub> hepatotoxicity becomes pertinent in these studies. Mirex, photomirex (10 ppm in the dietary protocol), or phenobarbital (225 ppm in the dietary protocol) induce cytochrome P-450 to a greater extent than chlordecone, in a completely inverse relationship to the propensity to potentiate CCl<sub>4</sub> toxicity [3-5]. Even though pre-exposure to chlordecone results in a slightly greater bioactivation of CCl<sub>4</sub> when expressed as CCl<sub>4</sub> metabolized per nanomole P-450 in comparison to phenobarbital or mirex pretreatments, this slight increase in bioactivation is inadequate to explain the enormous amplification of CCl<sub>4</sub> toxicity. The time-course histomorphometric studies [108,109] reveal no indication of earlier onset of toxicity or greater toxicity with chlordecone + CCl<sub>4</sub> treatment in comparison to CCl<sub>4</sub> treatment alone. These and other inferences [5,13,26] corroborate the proposal that the mechanism of chlordecone potentiation of CCl<sub>4</sub> toxicity cannot be explained by enhanced bioactivation of CCl<sub>4</sub>.

Interest in the role of liver microsomal cytochrome P-450 was rekindled with the concern about the slightly decreased P-450 content in PH (20%) livers [110,111]. A reasonable criticism could be leveled on the model on the basis of decreased P-450 seen in regenerating livers. Whether such small decreases might influence the toxicity of chlordecone + CCl<sub>4</sub> treatment, and hence explain the protection afforded by PH, was investigated [110]. Cobalt II chloride (CoCl<sub>2</sub>) treatment (60 mg/kg/day, sc, two days) was employed to decrease the hepatic microsomal P-450 content. One group of saline-injected and another group of CoCl<sub>2</sub>-injected rats were used to determine hepatic microsomal P-450. Another group of similarly treated rats was dosed with CCl<sub>4</sub> in corn oil (100 μL/kg, ip) or with plain corn oil. Cytochrome P-450 was decreased by approximately 60% in normal rats and in rats that were subjected to the 10-ppm, 15-day dietary protocol [110]. Even a 62% decrease in microsomal P-450 content did not affect the liver injury associated with chlordecone + CCl<sub>4</sub> treatment [110]. These findings indicate that the slight decreases in hepatic microsomal cytochrome P-450 levels seen in PH are unlikely to explain the protection from the toxicity of chlordecone + CCl<sub>4</sub> combination treatment in PH rats.

In view of the previously demonstrated ability of chlordecone at higher doses to inhibit mitochondrial energy metabolism [115-117], it was of interest to examine the effect of 10 ppm chlordecone on the energy status of the hepatocytes. Hepatomitochondria were isolated from rats maintained either on a normal powdered diet, or on a 10-ppm chlordecone diet for 15 days. Mitochondrial Mg<sup>2+</sup>-ATPase (MATPase) as well as other ATPase activities were determined. Oligomycin-sensitive MATPase was not affected by 10 ppm chlordecone [118]. Hepatic ATP levels were estimated in liver samples quick-frozen in liquid nitrogen. ATP levels were not affected significantly by the dietary exposure to chlordecone [118]. These findings indicate that at this nontoxic level, chlordecone does not affect these parameters of hepatic energy metabolism. Therefore, it appears that while exposure to five- to tenfold higher levels of chlordecone is known to interfere with hepatocellular energy metabolism, the low, nontoxic level used for the halomethane interaction studies does not interfere with this aspect of hepatocellular biochemistry. In this connection it should be noted that the findings concerning the effect of chlordecone treatment on hepatic Ca<sup>2+</sup> levels [105] are consistent with the above data. Treatment with chlordecone even up to 10 times this level used in the interaction studies does not increase hepatic Ca<sup>2+</sup> [105].

The possibility remains that the chlordecone + CCl<sub>4</sub> combination treatment may result in severely impaired energy metabolism in the liver. Recent studies have shown that hepatic ATP levels may be depleted within 1 h after the administration of CCl<sub>4</sub> to rats pre-exposed to 10 ppm chlordecone [118]. The same studies show that same dose of CCl<sub>4</sub> alone has no effect on the energy metabolism in the liver. Furthermore, mirex + CCl<sub>4</sub> combination, which does not cause significant amplification of toxicity, does not significantly affect ATP. Phenobarbital, which amplifies 40-fold

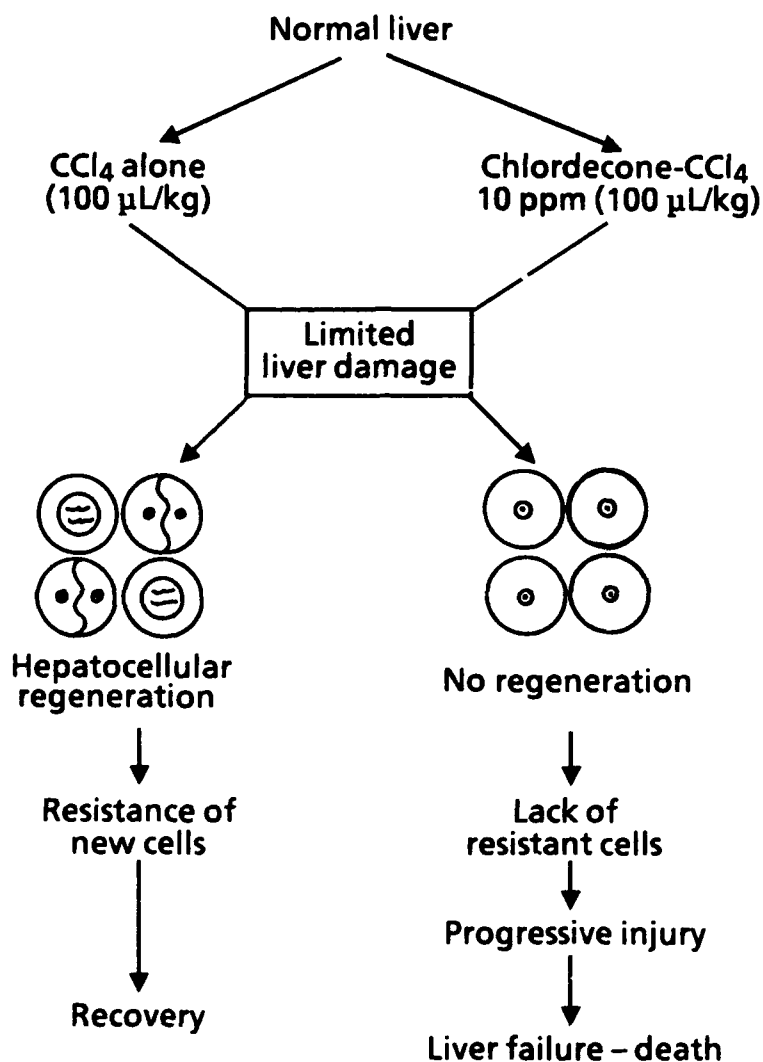
lesser CCl<sub>4</sub> toxicity than chlordecone + CCl<sub>4</sub>, caused a much lesser and only a transient decrease in ATP content [118]. This line of investigations has been pursued in additional studies [119,120]. If availability of cellular energy is the mechanism underlying the failure of the hepatocytes to divide during the critical early period of progressive injury, then providing an external source of cellular energy during that time should result in protection from liver injury. Administration of fructose 1,6-diphosphate immediately following CCl<sub>4</sub> injection to chlordecone-treated rats resulted in significant protection for CCl<sub>4</sub> liver injury [119]. Likewise, protection also was observed from a toxic dose of CCl<sub>4</sub> administered to normal animals [120]. In both cases, the protection was accompanied by increased ATP levels.

#### **PROPOSED MECHANISM: A HYPOTHESIS**

Based on several lines of experimental evidence, a hypothesis can be proposed [32] for the mechanism of the highly amplified toxicity of CCl<sub>4</sub> by chlordecone (Figure 4). The figure also illustrates the mechanism of recovery from the limited liver injury observed when a low dose of CCl<sub>4</sub> alone is administered. Within 6 h after the administration of a low dose of CCl<sub>4</sub>, the liver tissue responds by stimulating hepatocellular regeneration [108,109]. Most interestingly, this hepatocellular division is maximal at 6 h, even though the limited injury evident as centrilobular necrosis is only beginning to manifest. The limited hepatocellular necrosis enters the progressive phase, as has been demonstrated, at 12 h [108,109], while the hepatocellular regeneration and tissue repair continues simultaneously. By 24 h no significant injury is evident. These observations allow one to propose that stimulation of hepatocellular regeneration is a protective response of the liver, occurs very early after the administration of a low dose of CCl<sub>4</sub>, and leads to replacement of dead cells, thus restoring the hepatolobular architecture. Furthermore, it can be proposed that this remarkable biological event results in another important protective action. It is known that newly divided liver cells are relatively resistant to toxic chemicals [121-123]. Therefore, not only is the hepatolobular architecture restored by cell division, but also by virtue of the relatively greater injury during the progressive phase (6 to 12 h), speeding up the process of overall recovery. Maintaining the integrity of hepatolobular structure, especially with cells of greater resistance during the progressive phase of liver injury, is particularly significant. At later time points (12 h and onward), most of the CCl<sub>4</sub> would have been eliminated by the animal [73,74] and, hence, cellular regeneration at later time points is not as critical as at earlier time points during the progressive phase of injury.

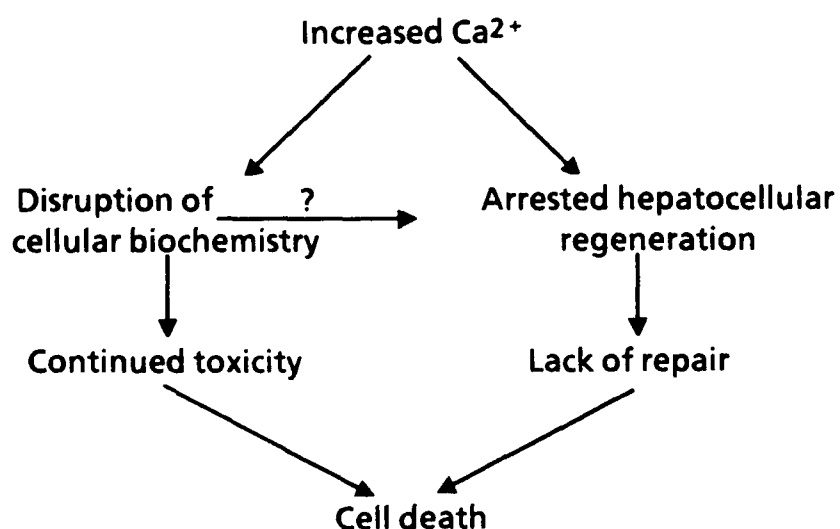
The mechanism underlying the highly unusual amplification of CCl<sub>4</sub> toxicity relates to the suppression of the initial hepatocellular regeneration, otherwise ordinarily stimulated by CCl<sub>4</sub> (Figure 4, right side). The failure of cell division has two important implications: (1) the integrity of hepatolobular structure cannot be restored; and (2) unavailability of newly divided, relatively resistant cells predisposes the liver to continuation of liver injury during the progressive phase (6 to

12 h and beyond). Slightly greater injury observed at 6 h after CCl<sub>4</sub> administration in chlordecone-treated rats [38,39] is consistent with the slightly increased bioactivation of CCl<sub>4</sub> [26,27]. This injury now is allowed to rapidly enter a progressive phase leading to complete hepatic failure [1-16] and animal death [5-16].

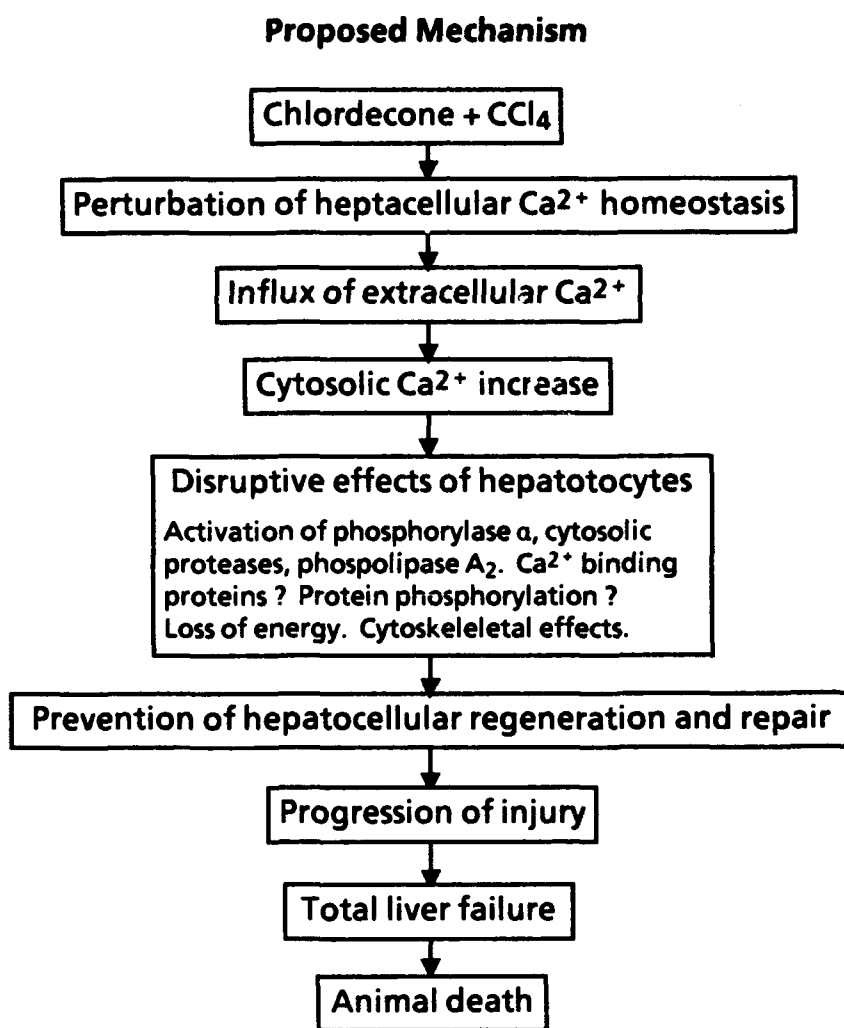


**Figure 4. Proposed Mechanism for the Highly Amplified Potentiation of CCl<sub>4</sub> Toxicity by Chlordecone.** The scheme depicts the concept of suppressed hepatocellular regeneration, simply permitting what is normally limited liver injury by a subtoxic dose of CCl<sub>4</sub> to progress in the absence of hepatolobular repair. This progression of toxicity accompanied by a lack of hepatolobular restoration is observed after the chlordecone + CCl<sub>4</sub> combination treatment leads to complete hepatic failure, culminating in animal death. Reproduced with permission from Mehendale (In Press) [32].

Many studies have shown a biphasic increase in hepatocellular  $\text{Ca}^{2+}$  levels in  $\text{CCl}_4$  toxicity [98-100, 104-107]. The unusual aspect of excessive  $\text{Ca}^{2+}$  accumulation observed in livers treated with the chlordecone +  $\text{CCl}_4$  combination is that it occurs at a dose of  $\text{CCl}_4$  not ordinarily associated with increasing hepatic  $\text{Ca}^{2+}$ . Furthermore, chlordecone alone, even at 10 times the higher dose than used in the interaction studies, does not increase hepatocellular  $\text{Ca}^{2+}$  [105]. Although *in vitro* studies with cellular organelles have been employed to speculate that the failure of organelle  $\text{Ca}^{2+}$  pumps leads to increased cytosolic  $\text{Ca}^{2+}$  levels [98, 102], our studies indicate that at no time point do these organelles contain decreased  $\text{Ca}^{2+}$  [104-107]. Indeed, only significant change observed with regard to organelle  $\text{Ca}^{2+}$  is increased  $\text{Ca}^{2+}$  in the organelles in association with increased liver injury [104-107]. Therefore, there is no *in vivo* evidence for decreased  $\text{Ca}^{2+}$  content in the organelles, which is in contradiction to the *in vitro* work [98, 102]. Figure 5 illustrates a proposal on how  $\text{Ca}^{2+}$  might be involved in the progressive phase of the amplification of  $\text{CCl}_4$  hepatotoxicity by chlordecone. Although the primary mechanism leading to a highly amplified toxicity is a failure on the part of the biological events leading to hepatocellular division, increasing accumulation of extracellular  $\text{Ca}^{2+}$  [107] during the progressive phase of liver injury would be consistent with the proposed role for  $\text{Ca}^{2+}$ . Figure 6 illustrates the working hypothesis that integrates the biochemical events pursuant to accumulation of  $\text{Ca}^{2+}$  and the suppressed hepatocellular regeneration and failed tissue repair, leading to uncontrolled amplification of liver injury.



**Figure 5. A Conceptualization of How Excessive Hepatocellular Accumulation of  $\text{Ca}^{2+}$  Might Adversely Affect Cellular Biochemistry, Culminating in Arrested Hepatocellular Regeneration.** Reproduced with permission from Mehendale (In Press) [32].



**Figure 6. Proposed Mechanism for Chlordecone-Induced Amplification of  $\text{CCl}_4$  Toxicity Indicating the Biochemical Events Leading to the Failure of the Hepatocytes to Divide. Suppression of otherwise stimulated hepatocellular division leads to amplification of otherwise limited injury.**

#### **ACKNOWLEDGMENTS**

These studies were made possible by grant support from the U.S. Environmental Protection Agency R-811072.

Recent studies were supported by the Harry G. Armstrong Aerospace Medical Research Laboratory as part of the U.S. Air Force Installation Restoration Program funded under the defense environmental restoration account through EPA Award CR814053. The research described in this article has been reviewed by the Health Effects Research Laboratory, U.S. Environmental Protection Agency, and approved for publication. Approval does not signify that the contents necessarily reflect the views of the Agency nor does mention of trades or commercial products constitute endorsement

or recommendation for use. The author is the recipient of the 1988 Burroughs Wellcome Toxicology Scholar Award.

#### REFERENCES

- 1 Curtis, L.R., Williams, W.L. and Mehendale, H.M. (1979) Potentiation of the hepatotoxicity of carbon tetrachloride following pre-exposure to chlordane (Kepone) in the male rat. *Toxicol. Appl. Pharmacol.* 51, 283-293.
- 2 Curtis, L.R., Williams, W.L. and Mehendale, H.M. (1979) Biliary excretory dysfunction following exposure to photomirex and photomirex/carbon tetrachloride combination. *Toxicology* 13, 77-90.
- 3 Curtis, L.R. and Mehendale, H.M. (1980) Specificity of chlordane-induced potentiation of carbon tetrachloride toxicity. *Drug Metab. Dispos.* 8, 23-37.
- 4 Curtis, L.R., Thureson-Klein, A.K. and Mehendale, H.M. (1981) Ultrastructural correlates of specificity of chlordane-potentiated carbon tetrachloride hepatotoxicity. *J. Toxicol. Environ. Health* 7, 499-517.
- 5 Klingensmith, J.S. and Mehendale, H.M. (1982) Potentiation of CCl<sub>4</sub> lethality by chlordane. *Toxicol. Lett.* 11, 149-154.
- 6 Agarwal, A.K. and Mehendale, H.M. (1983) Potentiation of CCl<sub>4</sub> hepatotoxicity and lethality by chlordane in female rats. *Toxicology* 26, 231-242.
- 7 Klingensmith, J.S. and Mehendale, H.M. (1981) Potentiation of brominated halomethane hepatotoxicity by chlordane in the male rat. *Toxicol. Appl. Pharmacol.* 61, 378-384.
- 8 Agarwal, A.K. and Mehendale, H.M. (1982) Potentiation of bromotrichloromethane hepatotoxicity and lethality by chlordane pre-exposure in the rat. *Fundam. Appl. Toxicol.* 2, 161-167.
- 9 Agarwal, A.K. and Mehendale, H.M. (1983) Absence of potentiation of bromoform hepatotoxicity and lethality by chlordane. *Toxicol. Lett.* 15, 251-257.
- 10 Agarwal, A.K., Mehendale, H.M. and Berndt, W.O. (1983) Possible nephrotoxic effect of carbon tetrachloride and its interaction with chlordane. *Toxicol. Lett.* 17, 57-62.
- 11 Mehendale, H.M. and Lockard, V.G. (1982) Effect of chlordane on the hepatotoxicity of 1, 1, 2-trichloroethylene and bromobenzene. *Toxicologist* 2, 37.
- 12 Klingensmith, J.S., Lockard, V.G. and Mehendale, H.M. (1983) Acute hepatotoxicity and lethality of CCl<sub>4</sub> in chlordane pretreated rats. *Exp. Mol. Pathol.* 39, 1-10.
- 13 Klingensmith, J.S. and Mehendale, H.M. (1983) Hepatic microsomal metabolism of CCl<sub>4</sub> after pretreatment with chlordane, mirex or phenobarbital in male rats. *Drug Metab. Dispos.* 11, 329-334.
- 14 Agarwal, A.K. and Mehendale, H.M. (1984) Chlordane potentiation of CCl<sub>4</sub> hepatotoxicity on ovariectomized rats. *Toxicology* 29, 315-323.



- 15 Agarwal, A.K. and Mehendale, H.M. (1983) Effect of adrenalectomy on chlordecone potentiation of carbon tetrachloride hepatotoxicity. *Fundam. Appl. Toxicol.* 3, 507-511.
- 16 Mehendale, H.M. (1984) Potentiation of halomethane hepatotoxicity: Chlordecone and carbon tetrachloride. *Fundam. Appl. Toxicol.* 4, 295-308.
- 17 Hewitt, W.R., Miyajima, H., Cote, M.G. and Plaa, G.L. (1979) Acute alteration of chloroform-induced hepato- and nephrotoxicity by mirex and Kepone. *Toxicol. Appl. Pharmacol.* 48, 509-517.
- 18 Cianflone, D.J., Hewitt, W.R., Villeneave, D.C. and Plaa, G.L. (1980) Role of biotransformation in the alterations of chloroform hepatotoxicity produced by Kepone and mirex. *Toxicol. Appl. Pharmacol.* 53, 140-149.
- 19 Ijima, M., Cote, M.G. and Plaa, G.L. (1983) A semiquantitative morphologic assessment of chlordecone-potentiated chloroform hepatotoxicity. *Toxicol. Lett.* 17, 307-314.
- 20 Hewitt, L.A., Hewitt, W.R. and Plaa, G.L. (1983) Fractional hepatic localization of  $^{14}\text{CHCl}_3$  in mice and rats treated with chlordecone or mirex. *Fundam. Appl. Toxicol.* 3, 489-495.
- 21 Hewitt, L.A., Caille, G. and Plaa, G.L. (1986) Temporal relationships between biotransformation detoxication and chlordecone potentiation of chloroform-induced hepatotoxicity. *Can. J. Physiol. Pharmacol.* 64, 477-482.
- 22 Purushotham, K.R., Lockard, V.G. and Mehendale, H.M. (1988) Amplification of chloroform hepatotoxicity and lethality by dietary chlordecone in mice. *Toxicol. Pathol.* 16, 27-34.
- 23 Hewitt, W.R., Miyajima, H., Cote, M.G. and Plaa, G.L. (1980) Modification of haloalkane-induced hepatotoxicity by exogenous ketones and metabolic ketosis. *Fed. Proc.* 39, 3118-3123.
- 24 Charbonneau, M., Ijama, M., Cote, M.G. and Plaa, G.L. (1985) Temporal analysis of rat liver injury following potentiation of carbon tetrachloride hepatotoxicity with ketonic or ketogenic compounds. *Toxicology* 35, 95-112.
- 25 Glende, Jr., E.A. and Lee, P.Y. (1985) Isopropanol and chlordecone potentiation of carbon tetrachloride liver injury: Retention of potentiating action in hepatocyte suspensions prepared from rats given isopropanol or chlordecone. *Exp. Mol. Pathol.* 42, 167-174.
- 26 Mehendale, H.M. and Klingensmith, J.S. (1988) *In vivo* metabolism of  $\text{CCl}_4$  by rats pretreated with chlordecone, mirex or phenobarbital. *Toxicol. Appl. Pharmacol.* 93, 247-256.
- 27 Klingensmith, J.S. and Mehendale, H.M. (1984) Destruction of hepatic mixed function oxygenase parameters by  $\text{CCl}_4$  in rats following acute treatment with chlordecone, mirex and phenobarbital. *Life Sci.* 33, 2339-2348.
- 28 Davis, M.E. and Mehendale, H.M. (1980) Functional and biochemical correlates of chlordecone exposure and its enhancement of  $\text{CCl}_4$  hepatotoxicity. *Toxicology* 15, 91-103.
- 29 Recknagel, R.O. and Glende, Jr., E.A. (1977) Lipid peroxidation: A specific form of cellular injury. In D.H.K. Lee (Ed.), *Handbook of Physiology, Section 9*, American Physiological Society. Williams and Wilkins, Baltimore, MD, pp. 591-601.

- 30 Reynolds, E.S., Treinen, R.J., Farish, H.H. and Moslen, M.T. (1984) Relationships between pharmacokinetics of carbon tetrachloride conversion to carbon dioxide and chloroform and liver injury. *Arch. Toxicol. (Suppl.)* 7, 303-306.
- 31 Slater, T.F. (1984) Free-radical mechanisms in tissue injury. *Biochem. J.* 222, 1-15.
- 32 Mehendale, H.M. (1989) Amplification of hepatotoxicity and lethality of CCl<sub>4</sub> and CHCl<sub>3</sub> by chlordecone. *Rev. Biochem. Toxicol.* 10, 91-138.
- 33 Slater, T.F. (1966) Necrogenic action of carbon tetrachloride in the rat: A speculative mechanism based on activation. *Nature (London)* 209, 36-40.
- 34 Koch, R.R., Glende, Jr., E.A. and Recknagel, R.O. (1974) Hepatotoxicity of bromotrichloromethane: bond dissociation energy and lipid peroxidation. *Biochem. Pharmacol.* 23, 2907-2915.
- 35 Sipes, I.G., Krishna, G. and Gillette, J.R. (1977) Bioactivation of carbon tetrachloride, chloroform and bromotrichloromethane: Role of cytochrome P-450. *Life Sci.* 20, 1541-1548.
- 36 Symons, M.C.R., Albano, E., Slater, T.F. and Tomasi, A. (1982) Radiation mechanisms 22. Radiolysis of tetrachloromethane. *J. Chem. Soc. Faraday Trans.* 78, 2205-2214.
- 37 Connor, H.D., Thurman, R.G., Galiz, M.D. and Mason, R.P. (1986) The formation of a novel free-radical metabolite from CCl<sub>4</sub> in the perfused rat liver and *in vivo*. *J. Biol. Chem.* 261, 4542-4548.
- 38 Cameron, G.R. and Karunaratne, W.A.E. (1936) Carbon tetrachloride cirrhosis in relation to liver regeneration. *J. Pathol. Bacteriol.* 42, 1-22.
- 39 Butler, T.C. (1961) Reduction of carbon tetrachloride *in vivo* and reduction of carbon tetrachloride and chloroform *in vitro* by tissues and tissue homogenates. *J. Pharmacol. Exp. Ther.* 134, 311-319.
- 40 Paul, B.B. and Rubenstein, D. (1963) Metabolism of carbon tetrachloride and chloroform by the rat. *J. Pharmacol. Exp. Ther.* 141, 141-148.
- 41 Reynolds, E.S. (1963) Metabolism of CCl<sub>4</sub>-C<sup>14</sup> in livers of CCl<sub>4</sub> poisoned rats. *Fed. Proc.* 22, 360-370.
- 42 Recknagel, R.O. and Ghoshal, A.K. (1966) Lipoperoxidation as a vector in carbon tetrachloride hepatotoxicity. *Lab. Invest.* 15, 132-146.
- 43 Fowler, J.S.L. (1969) Carbon tetrachloride metabolism in the rabbit. *Br. J. Pharmacol.* 37, 733-737.
- 44 Shah, H., Hartman, S.P. and Weinhouse, S. (1979) Formation of carbonyl chloride in carbon tetrachloride metabolism by rat liver *in vitro*. *Cancer Res.* 39, 3942-3947.
- 45 Glende, Jr., E.A. (1972) Carbon tetrachloride-induced protection against carbon tetrachloride toxicity. The role of the liver microsomal drug-metabolizing system. *Biochem. Pharmacol.* 21, 1697-1702.

- 46 Ugazio, G., Koch, R.R. and Recknagel, R.O. (1972) Mechanism of protection against carbon tetrachloride by prior carbon tetrachloride administration. *Exp. Mol. Pathol.* 16, 281-185.
- 47 Lindstrom, L.D. and Anders, M.W. (1977) Studies on the mechanism of carbon tetrachloride autoprotection: Effect of protective dose of carbon tetrachloride on lipid peroxidation and glutathione peroxidase, glutathione-reductase. *Toxicol. Lett.* 1, 109-114.
- 48 Burdine, E., Gravela, E., Ugazio, G., Vannini, V. and Calligaro, A. (1973) Initiation of radical reactions and hepatotoxicity in rats poisoned with carbon tetrachloride or bromotrichloromethane. *Agents Actions* 4, 244-253.
- 49 Noguchi, T., Fong, K.L., Lai, E.K., Alexander, S., King, M.M., Olson, L., Poyer, J.L. and McCay, P.B. (1982) Specificity of a phenobarbital-induced cytochrome P-450 for metabolism of carbon tetrachloride to the trichloromethyl radical. *Biochem. Pharmacol.* 31, 615-624.
- 50 Poyer, J.L., McCay, P.B., Lai, E.K., Janzen, E.G. and Davis, E.R. (1980) Confirmation of assignment of the trichloromethyl radical spin adduct. <sup>14</sup>C-carbon tetrachloride metabolism *in vitro* and *in vivo*. *Biochem. Biophys. Res. Commun.* 94, 1154-1160.
- 51 Tomasi, A., Albano, E., Lott, K.A.K. and Slater, T.F. (1980) Spin trapping of free radical products of CCl<sub>4</sub> activation using pulse radiolysis and high energy radiation procedures. *FEBS Lett.* 122, 303-306.
- 52 Rosen, G.M. and Rauckman, E.J. (1982) Carbon tetrachloride-induced lipid peroxidation: A spin trapping study. *Toxicol. Lett.* 10, 337-344.
- 53 Cignoli, E.V. and Castro, J.A. (1971) Lipid peroxidation, necrosis and the *in vivo* depression of liver glucose-6-phosphatase by carbon tetrachloride. *Exp. Mol. Pathol.* 14, 43-56.
- 54 Green J. (1972) Vitamin E and the biological antioxidant theory, In: P.P. Nair and H.J. Hyden (Eds.), *Annals of NY Acad. Sci.*, Vol. 203, New York, NY, pp. 29-44.
- 55 Benedetti, A., Casini, A.F., Ferrali, M. and Comporti, M. (1979) Extraction and partial characterization of dialyzable products origination from the peroxidation of liver microsomal lipids and inhibiting microsomal glucose-6-phosphatase activity. *Biochem. Pharmacol.* 28, 2909-2918.
- 56 Ferrali, M., Fulceri, R., Benedetti, A. and Comporti, M. (1980) Effect of carbonyl compounds (4-hydroxyalkenals) originating from the peroxidation of liver microsomal lipids and inhibiting microsomal glucose-6-phosphatase activity. *Res. Commun. Chem. Pathol. Pharmacol.* 30, 99-112.
- 57 Harris, R.N. and Anders, M.W. (1981) 2-Propanol treatment induces selectively the metabolism of carbon tetrachloride to phosgene. Implications for carbon tetrachloride hepatotoxicity. *Drug Metab. Dispos.* 9, 551-556.
- 58 Bini, A., Vecchi, G., Vivoli, G., Vannini, V. and Cessi, C. (1975) Detection of early metabolites in rat liver after administration of CCl<sub>4</sub> and BrCCl<sub>3</sub>. *Pharmacol. Res. Commun.* 7, 143-149.
- 59 Torrielli, M., Ugazio, V.G., Gabriel, L. and Burdino, E. (1974) Effect of drug pretreatment on BrCCl<sub>3</sub>-induced liver injury. *Toxicology* 2, 321-326.

- 60 Davies, M.J. and Slater, T.F. (1986) Electron spin resonance spin trapping studies on the photolytic generation of halocarbon radicals. *Chem. Biol. Inter.* 58, 137-147.
- 61 Pohl, L.R. (1979) Biochemical toxicology of chloroform. *Rev. Biochem. Toxicol.* 1, 79-107.
- 62 Pohl, L.R., Bhooshan, B., Whittaker, N.F. and Krishna, G. (1973) Chloroform toxicity in mice: Correlation of renal and hepatic necrosis with covalent binding of metabolites to tissue macromolecules. *Exp. Mol. Pathol.* 19, 215-229.
- 63 Ilett, K.F., Reid, W.D., Sipes, I.G. and Krishna, G. (1973) Chloroform toxicity in mice: Correlation of renal and hepatic necrosis with covalent binding of metabolites to tissue macromolecules. *Exp. Mol. Pathol.* 19, 215-229.
- 64 Docks, E.L. and Krishna, G. (1976) The role of glutathione in chloroform-induced hepatotoxicity. *Exp. Mol. Pathol.* 24, 13-22.
- 65 Ekström, T. and Högberg, J. (1980) Chloroform-induced glutathione depletion and toxicity in freshly isolated hepatocytes. *Biochem. Pharmacol.* 29, 3059-3065.
- 66 Frank, H., Haussman, H.J. and Remmer, H. (1982) Metabolic activation of carbon tetrachloride: Induction of cytochrome P-450 with phenobarbital or 3-methylcholanthrene and its covalent binding. *Chem. Biol. Inter.* 40, 193-208.
- 67 DeGroot, H. and Haas, W. (1981) Self-catalyzed, O<sub>2</sub>-independent inactivation of NADPH-or dithionite-reduced microsomal cytochrome P-450 by carbon tetrachloride. *Biochem. Pharmacol.* 30, 2343-2347.
- 68 Fander, U., Haas, W. and Kröner, H. (1982) The damage of the hepatic mixed functional oxygenase system by CCl<sub>4</sub>: Significance of incorporation of <sup>14</sup>CCl<sub>4</sub> metabolites *in vivo*. *Exp. Mol. Pathol.* 36, 34-43.
- 69 Klaasen, C.D. and Plaa, G.L. (1966) Relative effects of various chlorinated hydrocarbons on liver and kidney function in mice. *Toxicol. Appl. Pharmacol.* 9, 139-151.
- 70 Brabeck, M.J., Owens, J.B., Kenel, M., Sorscher, D. and Cornich, H.H. (1982) Modification of methanol potentiation of CCl<sub>4</sub> toxicity in rats by chloramphenicol and salicylate. *Drug Chem. Toxicol.* 5, 143-154.
- 71 Pilon, D., Charbonneau, M., Brodeur, J. and Plaa, G.L. (1986) Metabolites and ketone body production following methyl-*n*-butyl ketone exposure as possible indices of methyl-*n*-butyl ketone potentiation of carbon tetrachloride hepatotoxicity. *Toxicol. Appl. Pharmacol.* 89, 49-59.
- 72 Jernigan, J.D., Pounds, J.G. and Harbison, R.D. (1983) Potentiation of chlorinated hydrocarbon toxicity by 2,5-hexanedione in primary cultures of adult hepatocytes. *Fundam. Appl. Toxicol.* 3, 22-26.
- 73 McLean, A.E.M. and McLean, E.K. (1966) The effect of diet and 1,1,1-trichloro-bis (p-chlorophenyl) ethane (DDT) on microsomal hydroxylating enzymes and on the sensitivity of rats to carbon tetrachloride poisoning. *Biochem. J.* 100, 564-571.
- 74 Carlson, G.P. (1975) Potentiation of carbon tetrachloride hepatotoxicity in rats in pretreatment with polychlorinated biphenyls. *Toxicology* 5, 69-77.

- 75 Suarez, K.A., Carlson, G.P., Fuller, G.C. and Fausto, N. (1972) Differential acute effects of phenobarbital and 3-methylcholanthrene pretreatment on CCl<sub>4</sub>-induced hepatotoxicity in rats. *Toxicol. Appl. Pharmacol.* 23, 171-177.
- 76 Pitchumoni, C.S., Stenger, R.J., Rosenthal, W.S. and Johnson, E.A. (1972) Effects of 3, 4-benzpyrene pretreatment on the hepatotoxicity of carbon tetrachloride in rats. *J. Pharmacol. Exp. Ther.* 181, 227-733.
- 77 Ferreyra, E.C., DeFenos, V.M., Bernacci, A.S., DeCastro, C.R. and Castro, J.A. (1977) Treatment of carbon tetrachloride-induced liver necrosis with chemical compounds. *Toxicol. Appl. Pharmacol.* 42, 513-521.
- 78 Smickler, E.A. and Hultin, T. (1966) Effects of SKF-525A and adrenalectomy on the amino acid incorporation by rat liver microsomes from normal and CCl<sub>4</sub>-treated rat. *Exp. Mol. Pathol.* 5, 504-515.
- 79 Kutob, S.D. and Plaa, G.L. (1962) The effect of acute ethanol intoxication on chloroform-induced liver damage. *J. Pharmacol. Exp. Ther.* 135, 245-251.
- 80 Branchflower, R.V. and Pohl, L.R. (1981) Investigation of the mechanism of the potentiation of chloroform-induced hepatotoxicity and nephrotoxicity by methyl-*n*-butyl ketone. *Toxicol. Appl. Pharmacol.* 61, 407-413.
- 81 Kluwe, W.M. and Hook, J.B. (1978) Polybrominated biphenyl-induced potentiation of chloroform toxicity. *Toxicol. Appl. Pharmacol.* 45, 861-869.
- 82 Klein, R.L., Thureson-Klein, A.K. and Mehendale, H.M. (1976) Ultrastructural effects of acute Kepone treatment in rats. *Proc. Electron Microsc. Soc. Am.* 34, 286-287.
- 83 Larson, P.S., Egle, J.L., Henniger, C.R., Lane, R.W. and Borzelleca, J.F. (1979) Acute, subchronic and chronic toxicity of chlordecone. *Toxicol. Appl. Pharmacol.* 48, 2941.
- 84 Gosselin, R.E., Hodge, H.C., Smith, R.P. and Gleason, M.N. (1976) Clinical toxicology of commercial products: Acute poisoning. The Williams and Wilkins Co., Baltimore, MD, pp 92-98.
- 85 Cannon, S.B. and Kimbrough, R.D. (1979) Short-term chlordecone toxicity in rats including effects on reproduction, pathological organ changes, and their reversibility. *Toxicol. Appl. Pharmacol.* 47, 469-476.
- 86 Guzelian, P.S., Vranian, G., Boylan, J.J., Cohn, W.J. and Blanke, R.V. (1980) Liver structure and function in patients poisoned with chlordecone (Kepone). *Gastroenterology* 78, 206-213.
- 87 Fabacher, D.L. and Hodgson, E. (1976) Induction of hepatic mixed function oxidase enzymes in adult and neonatal mice by Kepone and mirex. *Toxicol. Appl. Pharmacol.* 38, 71-77.
- 88 Mehendale, H.M., Takanake, A., Desai, D. and Ho, I.K. (1977) Effect of pre-exposure to Kepone on hepatic mixed-function oxidases in the female rat. *Toxicol. Appl. Pharmacol.* 44, 171-180.
- 89 Mehendale, H.M., Takanaka, A., Desai, D. and Ho, I.K. (1977) Kepone induction of hepatic mixed function oxidases in the male rat. *Life Sci.* 20, 991-998.

- 90 Kaminsky, L.S., Piper, L.J., MacMartin, D.N. and Fasco, M.J. (1978) Induction of hepatic microsomal cytochrome-P-450 by mirex and Kepone. *Toxicol. Appl. Pharmacol.* 43, 327-338.
- 91 Mehendale, H.M. (1977) Effect of pre-exposure to Kepone on the biliary excretion of imipramine and sulfobromophthalein. *Toxicol. Appl. Pharmacol.* 40, 247-259.
- 92 Mehendale, H.M., Onoda, K., Curtis, L.R. and Ho, I.K. (1979) Induction of hepatic mixed function oxidases of photomirex. *J. Agri. Food Chem.* 27, 1416-1418.
- 93 Reddrop, C.J., Cheeseman, K.H. and Slater, T.F. (1983) Correlations between common tests for assessment of liver damage: Indices of the hepatoprotective activity of promethazine in carbon tetrachloride hepatotoxicity. *Cell Biochem. Function* 1, 55-63.
- 94 Fouse, B.L. and Hodgson, E. (1985) Effect of chlordecone and mirex on the acute hepatotoxicity of acetaminophen in mice. *Toxicologist* 5, 26.
- 95 Klingensmith, J.S., 1982. Metabolism of CCl<sub>4</sub> in rats pretreated with chlordecone, mirex and phenobarbital. Ph.D. Dissertation, University of Mississippi Medical Center.
- 96 Hammond, B., Katzenellenbogen, B.S., Krauthammer, N. and McConnell, J. (1979) Estrogenic activity of the insecticide chlordecone (Kepone) and interaction with uterine estrogen receptors. *Proc. Natl. Acad. Sci. USA.* 76, 6641-6645.
- 97 Bulger, W.H., Muccitelli, R.M. and Kupfer, D. (1979) Studies on the estrogen activity of chlordecone (Kepone) in the rat: Effects on uterine estrogen receptor. *Mol. Pharmacol.*, 15, 515-524.
- 98 Moore, L. (1980) Inhibition of liver microsome calcium pump by *in vivo* administration of CCl<sub>4</sub>, CHCl<sub>3</sub> and 1,1-diichloroethylene (vinylidene chloride). *Biochem. Pharmacol.* 29, 2505-2511.
- 99 Kröner, H. (1982) The intracellular distribution of liver cell calcium in normal rats and one hour after administration of carbon tetrachloride. *Biochem. Pharmacol.* 31, 1069-1073.
- 100 Schanne, F.A.X., Kane, A.B., Young, E.E. and Farber, J.L. (1979) Calcium dependence of toxic cell death. A final common pathway. *Science* 206, 700-702.
- 101 Smuckler, E.S. (1966) Studies on carbon tetrachloride intoxication IV. Effect of carbon tetrachloride on liver slices and isolated organaelles *in vitro*. *Lab Invest.* 15, 157-166.
- 102 Lowery, K., Glende, Jr., E.A. and Recknagel, R.O. (1981) Destruction of liver microsomal calcium pump activity by carbon tetrachloride and bromotrichloromethane. *Biochem. Pharmacol.* 30, 135-140.
- 103 Manring, J.A. and Moreland, D.E. (1981) Effects of chlordecone on isolated rat liver mitochondria. *Toxicol. Appl. Pharmacol.* 59, 483-488.
- 104 Agarwal, A.K. and Mehendale, H.M. (1984) CCl<sub>4</sub>-induced alterations in Ca<sup>2+</sup> homeostasis in chlordecone and phenobarbital pretreated animals. *Life Sci.* 34, 141-148.
- 105 Agarwal, A.K. and Mehendale, H.M. (1984) Excessive hepatic accumulation of intracellular Ca<sup>2+</sup> in chlordecone potentiated CCl<sub>4</sub> toxicity. *Toxicology* 30, 17-24.

- 106 Agarwal, A.K. and Mehendale, H.M. (1984) Perturbation of calcium homeostasis by CCl<sub>4</sub> in chlordecone and phenobarbital pretreated rats. *Environ. Health Persp.* 57, 289-291.
- 107 Agarwal, A.K. and Mehendale, H.M. (1986) Effect of chlordecone on carbon tetrachloride-induced increase in calcium uptake in isolated perfused rat liver. *Toxicol. Appl. Pharmacol.* 83, 342-348.
- 108 Lockard, V.G., O'Neal, R.M. and Mehendale, H.M. (1983) Chlordecone-induced potentiation of carbon tetrachloride hepatotoxicity: A light and electron microscopic study. *Exp. Mol. Pathol.* 39, 230-245.
- 109 Lockard, V.G., O'Neal, R.M. and Mehendale, H.M. (1983) Chlordecone-induced potentiation of carbon tetrachloride hepatotoxicity: A morphometric and biochemical study. *Exp. Mol. Pathol.* 39, 246-255.
- 110 Bell, A.N., Young, R.A., Lockard, V.G. and Mehendale, H.M. (1988) Protection of chlordecone-potentiated carbon tetrachloride hepatotoxicity and lethality by partial hepatectomy. *Arch. Toxicol.* 61, 392-405.
- 111 Kodavanti, P.R., Joshi, U.M., Young, R.A. and Mehendale, H.M. (1989) Chlordecone (Kepone®)-potentiated carbon tetrachloride hepatotoxicity in partially hepatectomized rats. A histomorphometric study. *J. Appl. Toxicol.* 9, 367-375.
- 112 Higgins, G.M. and Anderson, R.M. (1931) Experimental pathology of the liver. I. Restoration of the liver of the white rat following partial surgical removal. *Arch. Pathol.* 12, 186-202.
- 113 Henderson, P.T. and Kersten, K.J. (1970) Metabolism of drugs during rat liver regeneration. *Biochem. Pharmacol.* 19, 2343-2351.
- 114 Barker, E.D., Arcasoy, M. and Smuckler, E.A. (1969) A comparison of the effects of partial surgical and partial chemical (CCl<sub>4</sub>) hepatectomy on microsomal cytochrome b<sub>5</sub> and P-450 and oxidative N-demethylation. *Agents Actions* 1, 27-34.
- 115 Desaiah, D., Ho, I.K. and Mehendale, H.M. (1977) Effects of Kepone and mirex on mitochondrial Mg<sup>2+</sup>-ATPase activity in rat liver. *Toxicol. Appl. Pharmacol.* 39, 219-228.
- 116 Desaiah, D., Ho, I.K. and Mehendale, H.M. (1977) Inhibition of mitochondrial Mg<sup>2+</sup>-ATPase activity in isolated perfused rat liver by Kepone. *Biochem. Pharmacol.* 26, 1115-1159.
- 117 Carmines, E.L., Carchman, R.A. and Borzelleca, J.F. (1979) Kepone: Cellular sites of action. *Toxicol. Appl. Pharmacol.* 49, 543-550.
- 118 Prasada Rao, K.S., Joshi, U.M. and Mehendale, H.M. (1988) Hepatic energy status during CCl<sub>4</sub> toxicity in rats pretreated with chlordecone, mirex and phenobarbital. *Toxicologist* 8, 66.
- 119 Mehendale, H.M. and Rao, S.B. (1988) Protective role of fructose 1, 6-bisphosphate during CCl<sub>4</sub> hepatotoxicity. 196th ACS Meeting, Abst. 167, Los Angeles, CA.
- 120 Rao, S.B. and Mehendale, H.M. (1989) Protection from chlordecone (Kepone®)-potentiated CCl<sub>4</sub> hepatotoxicity in rats by fructose 1, 6-diphosphate, *Int. J. Biochem.* 21, 949-954.

- 121 Chang, L.W., Periera, M.A. and Klaunig, J.E. (1985) Cytotoxicity of halogenated alkanes in primary cultures of rat hepatocytes from normal partial hepatectomized and preneoplastic/neoplastic liver. *Toxicol. Appl. Pharmacol.* 80, 274-283.
- 122 Roberts, E., Ahluwalia, M.B., Lee, G., Chan, C., Sharma, D.S.R. and Farber, E. (1983) Resistance to hepatotoxins acquired by hepatocytes during liver regeneration. *Cancer Res.* 43, 28-34.
- 123 Ruch, R.J., Klaunig, J.E. and Pereira, M.A. (1985) Selective resistance to cytotoxic agents in hepatocytes isolated from partially hepatectomized and neoplastic mouse liver. *Cancer Lett.* 25, 295-301.
- 124 Ahmadizadeh, M., Kuo, C., Echt, R., and Hook, J.B. (1984) Effect of polybrominated biphenyls,  $\beta$ -naphthoflavone and phenobarbital on arylhydrocarbon hydrolase activities and chloroform-induced nephrotoxicity and hepatotoxicity in male C57 132/6J and DBA/2J mice. *Toxicology* 31, 342-352.



## SUBMARINE ATMOSPHERES

Douglas R. Knight<sup>1</sup>, Donald V. Tappan<sup>1</sup>, Jeffrey S. Bowman<sup>1</sup>, Hugh J. O'Neill<sup>2</sup>, and Syndey M. Gordon<sup>2</sup>

<sup>1</sup>*Naval Submarine Medical Research Laboratory, Groton, CT 06349-5900*

<sup>2</sup>*IIT Research Institute, 10 West 35 Street, Chicago, IL 60616*

### SUMMARY

Nuclear submariners live and work in an atmosphere composed of approximately 80% naturally occurring nitrogen, 19% oxygen (manufactured aboard ship), and a complex mixture of inorganic and organic contaminants. The concentrations of contaminants exist as a balance between the rates of production from human and operational activities and the rate of removal by engineering systems. The biological effects of inorganic gases, particularly carbon dioxide, have been extensively studied. Investigators are now attempting to define the composition and concentration of volatile organic compounds that accumulate during 90-day submergences. Medical studies have not conclusively shown that crewmembers incur adverse health effects from continuous exposures to the sealed atmospheres of nuclear submarines.

### HISTORICAL REVIEW

Vast improvements in propulsion plants and air purification systems have effectively lowered the risk of acute intoxication from exposure to submarine atmospheres. World War I crews risked acute poisoning by exposure to the fumes of gasoline engines and batteries in submarines that were not equipped with air reclamation systems. The submergence time of these ships was limited by the environmental effects of human metabolism, which raised the percentage of atmospheric carbon dioxide (CO<sub>2</sub>) and lowered the percentage of atmospheric oxygen (O<sub>2</sub>) in approximately a 1:1 ratio. Crewmembers experienced symptoms of breathlessness after 8 to 17 h of respiration changed their unprocessed and stagnant atmosphere to 15% O<sub>2</sub> and 5% CO<sub>2</sub>. Odors were particularly annoying due to the inadequate facilities for personal hygiene and the lack of air purification devices [1,2].

During the South Pacific operations of World War II crewmembers were menaced with labored breathing, headaches, dehydration, and syncope during submergences in diesel-electric submarines that extended beyond the daytime period. The standard procedure for revitalizing the atmosphere was to ventilate the ship with fresh air at nighttime in order to sustain the metabolic requirements for oxygen during daytime submergences. The submarines were not equipped with air conditioning systems for dissipating excess heat into the tropical oceans, and lithium hydroxide (LiOH) was only used to scrub excess CO<sub>2</sub> from the atmosphere in emergency situations. Oxygen deficiency was detected by the inability to light cigarettes rather than by routine monitoring of the ship's atmosphere. Each submarine carried a limited number of chlorate candles to provide the crew an

emergency source of O<sub>2</sub>. Charcoal filters helped improve the atmosphere by partially removing annoying odors, but the greatest improvement in habitability occurred toward the end of the War when advanced systems were installed to recirculate the air through air conditioning plants [3-5].

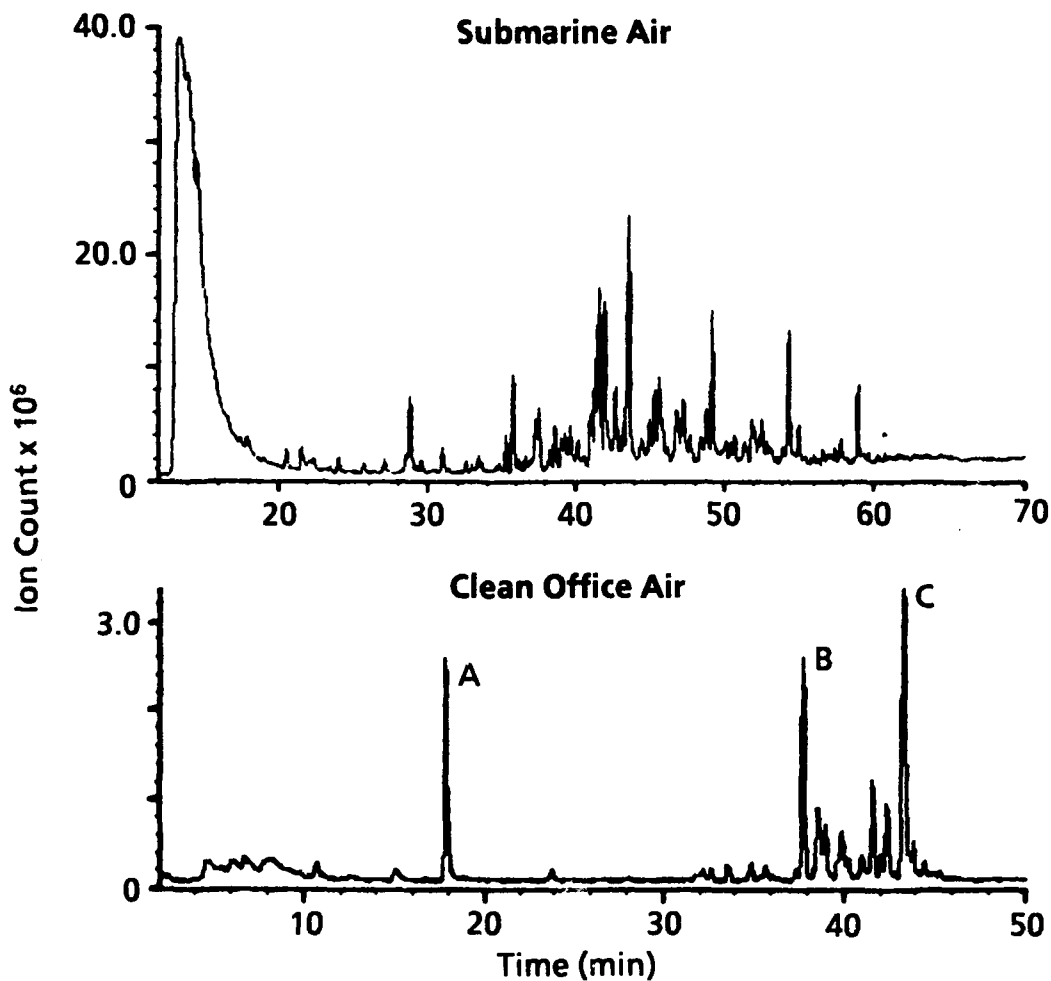
As a prelude to the deployment of nuclear submarines, it was necessary for physiologists to define the concentrations of CO<sub>2</sub> for safe habitation. The use of LiOH to remove CO<sub>2</sub> was deemed impractical due to the excessive quantity of chemicals needed for long patrols. Therefore, new machinery was designed to absorb CO<sub>2</sub> with recycled monoethanolamine [2,6,7].

The first nuclear submarine, the USS Nautilus, set a submergence record of 11 days. It was during this habitability cruise in 1956 that chemists discovered a variety of different hydrocarbons in high atmospheric concentrations. (This proved to be of more than academic interest as there were instances in later submarine patrols when the irritating effects of atmospheric contaminants interfered with crew performance.) The progressive accumulation of pollutant gases during multiday submergences established the need to minimize the rate of release of chemical vapors into the atmosphere while at the same time maintaining an acceptable rate of removal. The Navy published a restricted items list for the exclusion or limitation of organic solvents and toxic chemicals from submarines. Hopcalite® was placed in catalytic burners to accelerate the thermal conversion of carbon monoxide, hydrogen, and hydrocarbon molecules to CO<sub>2</sub> and water [2,8]. The length of submergences was now limited by the shipboard supply of O<sub>2</sub> for metabolic consumption. The USS Seawolf used auxiliary stores of O<sub>2</sub> to sustain its crew during a 60-day submergence. Later classes of nuclear submarines were fitted with generators that manufactured O<sub>2</sub> by the electrolysis of water [2]. The nuclear submarines also were equipped with gas analyzers to monitor the composition of the atmosphere on a continual basis.

Today's submarine atmospheres are still contaminated with trace concentrations of many organic compounds. This is illustrated in Figure 1, which shows the ion chromatograms of equal-volume air samples taken from a submarine's atmosphere (upper panel) and a clean office (lower panel). The submarine air contained more compounds at higher concentrations than did office air. These compounds were volatile organic compounds (VOCs) that consisted of long chain aliphatic hydrocarbons, aromatic compounds, and halocarbons. The list of organic pollutants currently identified aboard nuclear submarines is too long for this discussion; however, reviews by Carhart and Johnson [6] and the National Academy of Sciences [9,10] provide interesting discussions of these complex mixtures.

It is currently thought that the concentrations of oxygen and pollutants are nearly uniform throughout the ship due to the rapid recirculation of air between compartments [10,11]. An exception to this may be the differential distribution of aerosols between the engineer room and forward compartment. During the first decade of nuclear submarine operations, the total aerosol concentration (0.5 mg/m<sup>3</sup>) was five times that of the aerosols measured in fresh country air and twice

that observed in large industrial cities. A "blue haze" of oil droplets (diameter  $\geq 0.4 \mu\text{m}$ ) was predominantly distributed in the engine room and occasionally irritated the machinists. Respirable droplets in the forward end of the ship (diameter  $\leq 0.4 \mu\text{m}$ ) were largely derived from cigarette smoke and predominantly distributed in the forward compartment. The deposition of these mists caused failures of electronic equipment and reduced the efficiency of cooling coils. Lower concentrations of aerosols were measured after the capacities of the ship's electrostatic precipitators were increased [10,12,13]. Recent measurements have shown a lower concentration of total aerosols in the forward compartment ( $0.1 \text{ mg/m}^3$ ) than in the engine room ( $0.2 \text{ mg/m}^3$ ) [14].

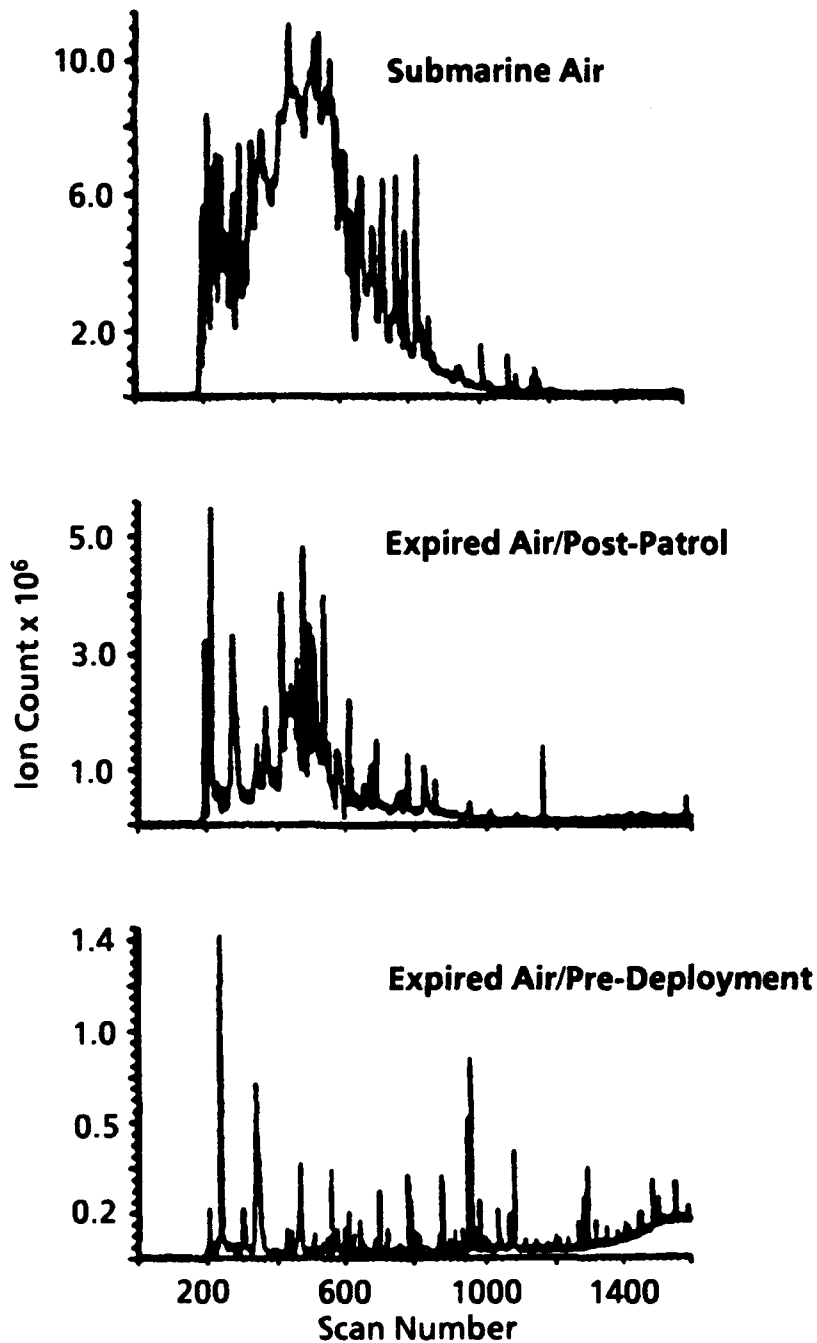


**Figure 1. Total Ion Chromatograms of Submarine Air and Office Air.** Both air samples were analyzed by chemists at the Naval Submarine Medical Research Laboratory. X axis: the time when different constituents of the air sample emerged from the gas chromatograph. Y axis: the count of ions generated by the mass spectrometer for each constituent emerging from the gas chromatograph. The concentrations of the contaminants are proportional to the areas of their characteristic peaks on the total ion chromatogram. Peaks A and B are markers for *n*-heptane (39 ppb) and indene (39 ppb), respectively. Peak C is a C11 hydrocarbon.

## BIOMONITORING

Schaefer [15] postulated that the environmental stress and altered life styles that characterize occupational exposures to nuclear submarines cause a variety of subtle changes in organ function. Field studies implied that the 0.7 to 1.0% concentrations of CO<sub>2</sub> alter the permeability of red blood cells, increase the gastric acidity, raise the respiratory minute volume, produce cycles of metabolic and respiratory acidosis, and alter the calcium excretion in urine. Furthermore, the absence of sunlight may interact with CO<sub>2</sub> to reduce the urinary excretion of calcium. The resulting cycles of urinary calcium excretion were thought to indicate that bone serves to buffer the cycles of respiratory acidosis [15]. This prompted Messier et al. [16] to examine the hypothesis that submarine duty changes the bone mineral content as a result of exposure to the combined effects of atmospheric CO<sub>2</sub>, demineralized water, lack of sunlight, and diminished physical activity. When submarine veterans (n = 10) were studied by total body neutron activation analysis, the total body mass of potassium and calcium were the same in the veterans as in a control population of civilians matched for age, weight, and height. In active duty submariners (n = 39), the bone mineral content of the left radius was measured by photon absorptiometry. The submariners had the same bone mineral content as a control population of civilians. The investigators computed the normalized bone mineral content of the active duty and retired submariners and found no substantial alteration as a function of submergence times between 6 and 52 months. The investigators concluded that repeated and prolonged exposures to the submarine environment did not produce cumulative changes in skeletal mass [16,17].

We recently studied the bio-uptake of VOCs by collecting samples of the expired breath from a submariner before and after an 82-day patrol. The subject, a nonsmoker, inhaled purified air through a Teflon® manifold and exhaled into a Teflon® bag. The expired VOCs were harvested for laboratory analysis by drawing the collected gas through Tenax® gas chromatograph-absorbent material. Total ion chromatograms of the submarine air and expired breath samples are shown in Figure 2. The major classes of VOCs in submarine air were the alkanes, aromatics, and O<sub>2</sub>-containing organic compounds. The pre-patrol breath samples contained oxygenated-organic compounds and alkenes (principally isoprene) as the major classes of VOCs. Immediately after patrol, the predominant VOCs in expired air were the alkanes and halocarbons. The results of this trial study seem to suggest that occupational exposures to submarines alter the composition of VOCs in the expired breath.



**Figure 2.** Composition of a Crewmember's Expired Breath. The axes have the same meaning as defined in the legend of Figure 1. The pre-deployment and post-patrol breath samples were collected outside of the submarine in comfortable rooms.

The bio-uptake of cadmium was studied [unpublished observation of Bowman and Bondi] by collecting samples of hair, blood, and urine from crewmembers during a two-month submarine patrol. Analyses of the air, blood, and urine yielded cadmium concentrations at or below the detection capability of the instruments. The hair samples of submariners had higher concentrations

of cadmium than observed in hair samples taken from nonsubmariners. Thirty days after patrol, the cadmium levels in hair were approximately back to those found before patrol. Of particular interest was the observation that cadmium contamination of the hair varied according to location of the submariner's watchstation aboard ship. The results indicated that (1) submariners may absorb cadmium as a function of the location of their watchstation and (2) the route of cadmium absorption may be through skin rather than the lung. More comprehensive studies are needed to define the uptake and metabolism of trace atmospheric contaminants by submarine crewmembers, particularly in relationship to the location of their watchstation aboard ship.

## **EPIDEMIOLOGY STUDIES**

The morbidity and mortality of submariners have been defined by three epidemiological studies spanning the time period from 1963 to 1980. There was a decrease of the illness rates in submariners from the period 1963 to 1967 to the period 1968 to 1973. The reduced rates of illness occurred in respiratory, otolaryngologic, gastrointestinal, cardiovascular, urologic, and infectious diseases. These changes were attributed to improvements in the atmosphere control program resulting from an increased capacity of the CO<sub>2</sub> scrubbers, more frequent replacement of the carbon filters, and the use of more efficient catalytic burners [18].

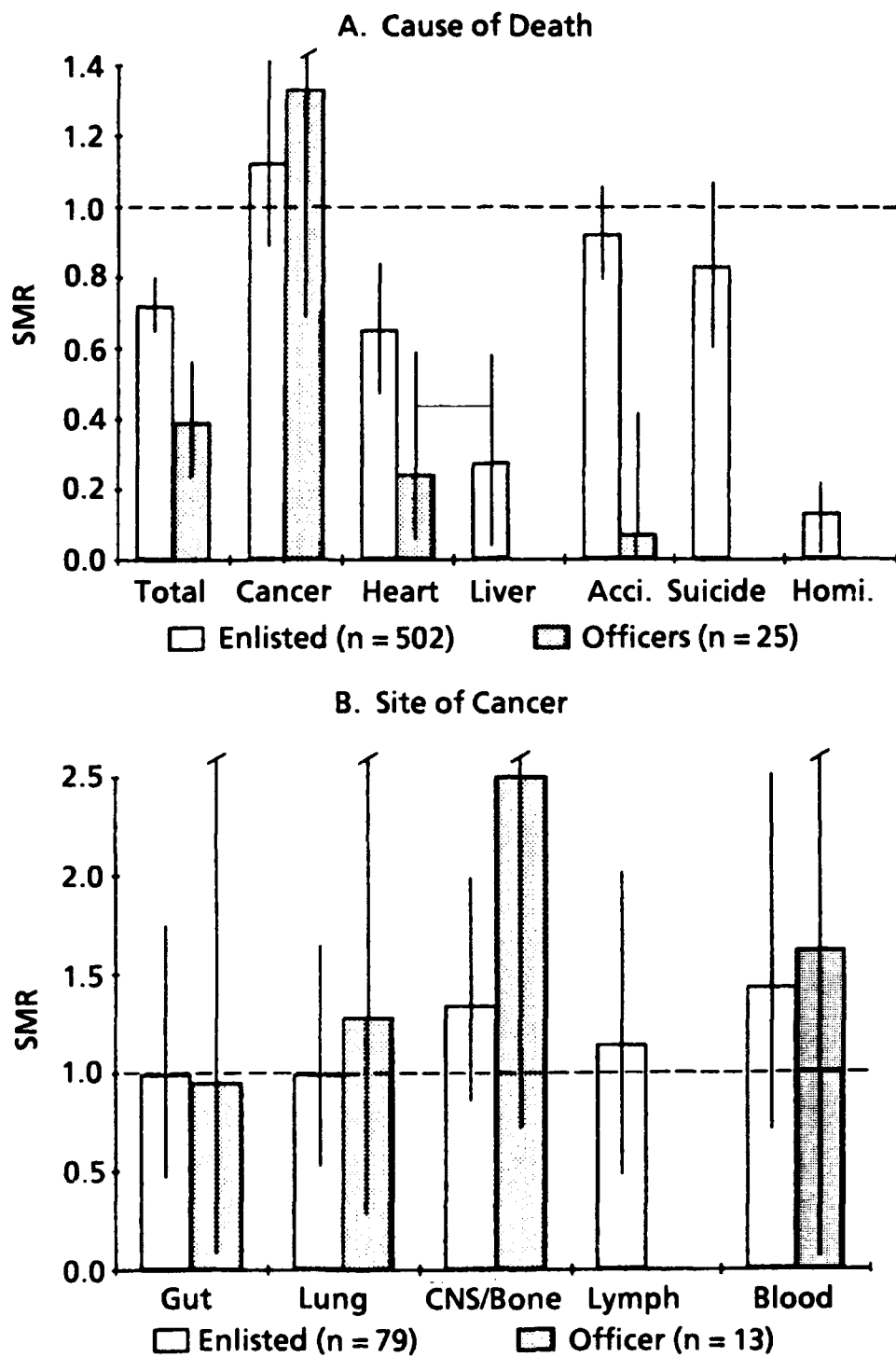
Tansey et al. [18] reviewed the medical officers' reports from a decade (1963 to 1973) of 885 Polaris submarine patrols. The investigators tabulated illnesses resulting in absence from duty for one sick day or longer, and excluded deaths (n = 5) and medical evacuations (n = 37). Illness rates were defined as the number of new cases per 1000 man-days at sea. According to the t-test statistics, submariners had significantly lower rates of respiratory illness, gastrointestinal disease, and infections than did the control population of sea-going sailors. There were no significant differences in the rates of skin ailments and urinary tract diseases between submariners and sailors; however, submariners had significantly higher rates of cranial, systemic, and neuropsychiatric illnesses. Dental problems and headaches accounted for the higher rates of cranial illness in submariners. The systemic illnesses included cardiovascular problems, arthritis, and systemic viral infections. The rate of neuropsychiatric illness was higher after 1967, which was consistent with national trends in neuropsychiatric illness [18].

Hospitalization records were used by Burr and Palinkas [19] to evaluate the health risks associated with submarine duty during the time period of 1974 to 1979. The control group was a random sample of white enlisted men serving aboard frigates or destroyers. Age-adjusted hospitalization rates (i.e., the number of admissions per 100,000 man-years) were computed for major diagnostic categories and health problems considered relevant to the potential health effects of submarine duty. The relative risk of submarine duty was defined as the quotient of hospitalization rate for submariners divided by hospitalization rate for surface sailers. The health risks of submarine duty were lower for all major disease categories, including diseases of the lung, malignancies, and

infections. The submariners were at significantly lower risks for mental disorders, external injuries, genitourinary diseases, skin disorders, and musculoskeletal diseases. Submariners tended to be at lower risk for asthma and higher risk for diseases of the kidney, ureter, and heart, but the relative risks were not significantly higher as determined by the use of 95% confidence intervals. Possible reasons for lower hospitalization rates of submariners were stringent medical screenings of candidates, their higher level of education, difficulty with conducting medical evacuations from deployed submarines, and the transfer of medically disqualified men from submarine duty. In the investigators' opinion, the health status of enlisted men was not adversely affected by submarine duty [19].

Ostfeld et al. [20] reviewed the mortality records of deceased crewmen to determine the risks associated with occupational exposure to trace contaminants of submarine atmospheres. The cohort consisted of 77,123 enlisted men and 8,628 officers who were on submarine duty between 1969 and 1981. Less than 2% of the veterans were unavailable for follow up after discharge from the Navy. Submariner mortality was evaluated by use of the standardized mortality ratio (SMR), which is the ratio of deaths observed in submariners to deaths expected from the mortality rates of the U.S. male population. Confidence intervals of 95% were calculated for the SMRs and inferences of significance were made when the confidence intervals excluded the SMR-value of 1.0 [20].

By the end of 1982, there were 351 in-service deaths and 527 out-of-service deaths. The SMRs for in-service deaths from all causes were considerably less than 1.0. These low mortality rates probably resulted from careful health screening of new recruits and the prompt discharge of medical disability cases from the Navy. The out-of-service death rates were lower than expected for diseases of the heart, lung, and liver. The SMRs in Figure 3 show that the veterans had the same number of deaths as expected for U.S. males from external causes (i.e., accidents, suicides, and homicides) and cancer. The accidental deaths of enlisted veterans were higher among those with history of demotions or duty aboard fast-attack submarines. There was clustering of cancer deaths in the year immediately following discharge from the Navy for medical disability. The rates of mortality from neoplasms of the bone, connective tissue, brain, and central nervous system were collectively 1.34 times higher than the death rates of the general U.S. male population (Figure 3). A log-linear model of death rates showed that length of service was a significant predictor of the cancer death rate, particularly death due to lung cancer. Unfortunately, data were not available on the risk factor of smoking. Specific occupation aboard the submarines was only marginally predictive of the cancer death rate, being relatively higher among technicians (85% of the enlisted cohort) than among administrative personnel. As a matter of speculation, Ostfeld et al. suggested that the contamination of submarine atmospheres has decreased over the years due to improvements in the air filtration system. Therefore, the probability of cancer induction from submarine duty-related exposures by this speculation would be much less now than in the past [20].



**Figure 3. Mortality Data of Submarine Veterans.** The data are taken from Ostfeld et al. [20]. The SMR is the ratio of observed to expected mortality rates for submariners. Each bar is intersected by a vertical line, which denotes the 95% confidence interval for that particular SMR. ABBREVIATIONS: Acci. is accidents; Homi. is homicide; and CNS/Bone refers to tumors of the central nervous system, bone, and connective tissues.



## CURRENT ISSUES

Eight decades of improvements in submarine atmospheres have diminished the concerns of environmental engineers for acute toxicity, explosive gases, corrosion of equipment, and unsuitability for habitation. However, atmospheric monitoring must continue to ensure that these problems do not recur with the introduction of new materials aboard ship. There is still the problem of selecting the most effective methods for monitoring submarine atmospheres with respect to the health of the crews [10].

The results of medical studies indicate that the atmospheres aboard today's submarines are not chronically toxic to the crews. In view of current developments in understanding the toxicity of complex mixtures [9], more work is needed to ascertain the biological activity of submarine atmospheres. A longer follow up of submariner mortality studies would be advantageous in assessing the risk for diseases of long latent periods.

It is doubtful that atmospheric contaminants are uniformly distributed throughout the submarine in view of the different densities of aerosols between the forward and the engineering spaces of the ship. This raises the possibility that crewmembers differentially absorb contaminants as a function of the location of their watchstation.

## REFERENCES

- 1 DuBois, E.F. (1919) Submarine Ventilation. Bulletin No. 4 (126632), Review of Recent Work on Air Purification in Submarines, Government Printing Office, Washington.
- 2 Miller, R.R. and Piatt, V.R. (1960) Chronology of submarine-atmosphere research. In: R.R. Miller and V.R. Piatt (Eds.), The Present Status of Chemical Research in Atmospheric Purification and Control on Nuclear-Powered Submarines, NRL Report 5465, U.S. Naval Research Laboratory, Washington, DC.
- 3 Jones, R.F. and Mankin, G.H., (1924) Studies of submarine ventilation in tropical waters. U.S. Nav. Med. Bul. 20, 759-795.
- 4 Kinsey, Jack L. (1953) Some Aspects of the Habitability of the Attack Class Submarines in Cold and Warm Waters, Report No. 218, Naval Submarine Medical Research Laboratory, Groton, CT.
- 5 Bureau of Naval Personnel (1946) The Fleet Type Submarine, NavPers 16160, Department of the Navy, Washington, DC.
- 6 Carhart, H.W. and Johnson, J.E. (1980) A History of the Naval Research Laboratory Contributions to Submarine Life Support Systems, Publication 80-ENAs-29, the American Society of Mechanical Engineers.
- 7 Anonymous (1982) The Toxic Effects of Chronic Exposures to Low Levels of Carbon Dioxide, Report No. 973, Naval Submarine Medical Research Laboratory, Groton, CT.

- 8 Johnson, J.E., Christian, J.G., Field, D.E., Murphy, C.M., Jr., Smith, J.E., Thomas, F.S. and Umstead M.E. (1961) Investigation of Eye Irritation in the Atmosphere of USS Snook, (SS(N)592) – Trip Report, NRL Memorandum Report 1248, The Naval Research Laboratory, Washington, DC.
- 9 Committee on Methods for the *In Vivo* Toxicity Testing of Complex Mixtures, National Research Council. (1988) Complex Mixtures. Methods for *In Vivo* Toxicity. National Academy of Sciences, Washington, DC.
- 10 Subcommittee on Submarine Air Quality, Committee on Toxicology, National Research Council. (1988) Monitoring the Air in Submarines, National Academy Press, Washington, DC.
- 11 Smith, W.D., Woods, F.J. and Umstead, M.E. (1965) Submarine Atmosphere Studies Aboard the USS Scamp, NRL Report 6312, the Naval Research Laboratory, Washington, DC.
- 12 Anderson, W.L. (1961) Aerosols in nuclear submarines. In: V.R. Piatt and E.A. Ramskill (Eds.), Annual Progress Report. The Present Status of Chemical Research in Atmosphere Purification and Control on Nuclear-Powered Submarines, NRL Report 5630, U.S. Naval Research Laboratory, Washington, DC.
- 13 Thomson, Gordon W. (1973) Summary of Aerosol Testing, EB Accession No. BA1080, General Dynamics, Electric Boat Division, Groton, CT.
- 14 Rossier, R.N. (1984) Trident Atmosphere Control Sea Trial, Final Report Contract No. 0024-73-C-0232, General Dynamics, Electric Boat Division, Groton, CT.
- 15 Schaefer, K.E. (1979) Editorial summary. Undersea Biomed. Res. 6 (suppl), s7-s14.
- 16 Messier, A.A., Cohn, S.H., Neer, R.M., Vaswani, A., Tappan, D.V. and Bondi, K.R. (1983) Bone and body mineral composition studies in active duty and retired submariners. In: Douglas R. Knight and Kenneth R. Bondi, (Eds.), Proceedings of the Third Tripartite Conference on Submarine Medicine, Special Report 83-1, Naval Submarine Medical Research Laboratory, Groton, CT.
- 17 Messier, A.A., Cohn, S.H., Neer, R.M., Vaswani, A., Tappan, D.V. and Bondi K.R. (1981) Assessment of bone and body composition in recently retired and active duty submariners. Fed. Proc 40, 920.
- 18 Tansey, W.A., Wilson, J.M. and Schaefer, K.E. (1979) Analysis of the health data from 10 years of Polaris submarine patrols. Undersea Biomed. Res. 6(suppl), s217-s246.
- 19 Burr, R.G. and Palinkas L.A. (1987) Health risks among submarine personnel in the U.S. Navy, 1974-1979, Undersea Biomed. Res. 14, 535-544.
- 20 Ostfeld, A.M., Charpentier, P.A. and Hadjimichael, O. (1987) Out-of-Service Mortality Among Nuclear Submariners Discharged 1969-1981. Yale University School of Medicine, Department of Epidemiology and Public Health, New Haven, CT.

**STUDIES IN THE SYNERGISTIC HEPATOTOXICITY OF CARBON TETRACHLORIDE AND  
TRICHLOROETHYLENE OR CHLOROFORM IN MALE F-344 RATS**

I. Glenn Sipes

*Department of Pharmacology and Toxicology,  
University of Arizona, College of Pharmacy, Tuscon, AZ 85721*

(Manuscript Not Submitted)

## SESSION II

### PANEL DISCUSSION

**Dr Paul Feder (Battelle Columbus Labs):** For Dr DeMarini. In your diagram you showed fractionation going from the top down. That would be appropriate if you thought that there might be several substances interacting together that gave you a toxic effect that you may not be able to see separately. If there were one or two major opponents, wouldn't there be the possibility of "diluting," so to speak, the effect of the bad guys with the relatively innocuous parts, or would you also want to start from the bottom up and test relatively pure fractions and then combine things where you found toxicity?

**DeMarini:** That is how you have to do the process. To get those relatively pure fractions, you have to start producing relatively crude fractions and then successively purify those. So it makes good sense that you are going through that process to do bioassays on those fractions, as you go along. The real meat of the data certainly comes at the end with the more purified fractions. Depending on how good your fractionation methods are, you begin to generate fractions that are more chemically homogeneous, such as aromatic amines, nitroaromatics, aliphatics, and then when one is identifying interesting biological activity in such a fraction it becomes much more amenable to analytical chemical analysis than fractions that are far more chemically complex and contain a large variety of different classes of chemicals. What you say makes sense, but in practice one has to work down to a more pure set of fractions.

**Dr George Anstadt (Miami Valley Hospital):** I have a question for Dr Sipes that I have often wondered about and never had the right person to ask. Of the other shorter-acting barbiturates than phenobarbital for instance, particularly pentobarbital, does it have the same potentiating effects or any degree of potentiating effects on carbon tetrachloride or things like that?

**Sipes:** Usually the shorter the acting duration of a barbiturate, the less inducing activity it has, but I think with pentobarbital, given in repeated doses, you could probably show some potentiated response because I think it can induce; it is just not as potent as phenobarbital.

**Anstadt:** Is there any documentation of the inducing capability of pentobarbital?

**Sipes:** I think there is evidence of its inducing capability, yes. But again, phenobarbital is a classic and it is more potent. Some of the other barbiturates, I think secobarbital, can actually destroy P-450 so it actually can have an inhibitory or antagonistic effect. It has an allyl group on it that destroys certain hemes, so, with some of these agents, you can get mixed effects. But I think the important thing to remember is the longer the duration of action, the greater inducing capability they have. The one

thing that I didn't point out is that there are many, many examples of environmental compounds that patients may be exposed to that have inducing capabilities.

**Anstadt:** I have one other question, if I dare ask it. It is a little bit irrelevant, but I have heard the comment that if the vaporizers were as good years ago as they were in the advent of halothane that chloroform would have been just as good of an anesthetic, if the vaporizers would be available for it, in terms of the hepatotoxicity of halothane versus chloroform. Do you have an opinion about the relative hepatotoxicity of chloroform versus halothane?

**Sipes:** Yes, I sure do. I certainly would not choose to be anesthetized with chloroform; I would much prefer halothane. We have worked on that compound for 15 years and it is tough to make it hepatotoxic. I will point out that chloroform, at least in my estimation, is not that hepatotoxic until you start doing a couple of things, including enzyme induction or glutathione depletion, and that is very easy to do in animals and it is very easy to do in humans. With halothane you have to work at it, and I will be happy to tell you later what our current feelings are in the mechanisms of halothane-induced injury, but with chloroform, you can reproducibly show on a variety of different animal models that it can be hepatotoxic.

**Dr Rory Conolly (NSI):** I would like to ask a question that really is addressed, I guess, to the whole panel. It is kind of a philosophical question about the studies of mixture toxicity. It is not meant to criticize any of the presentations today because they were really quite excellent with respect to the work that is being done on mixtures. But it seems to me that if mixture toxicity studies are going to be anything more than purely descriptive, that is, the sort of modern-day analog of the 1960s studies where we counted the number of legs and divided by four, that inevitably it leads you down to the question of what are the mechanisms of the components of the mixture, and understanding those mechanisms gives you some basis for understanding the kinds of interactions you are seeing and maybe making predictions about what you might expect. But given that it is true, you are led back to where we are with single compounds today, which is that we are all struggling to try and understand single compounds and in one of two cases doing fairly good jobs of it, but in most cases really having very little idea at all of what the mechanism of a toxic chemical is. So I guess my question is, where can we seriously expect mixture toxicity studies to go, given the limitations of our techniques and our understanding of even single compounds?

**Mehendale:** I believe the points you have made are well taken and I think we ought to pay greater attention to whether or not we are unraveling additional mechanisms from this combination of toxicology. Our own study with chlordecone, carbon tetrachloride and chlordecone, chloroform and chlordecone, and a few other compounds has suddenly led to a new approach to mechanisms. We would like to think that it is a new mechanism. For example, if chlordecone is a neurotoxic compound

when given in sufficient quantities, and when it is given at low levels, there is no indication of any kind of toxicity anywhere. We know how to measure it in that animal. And now, on top of that, the animal is exposed to a tiny bit of carbon tetrachloride, and enormous amplification of toxicity occurs, and it does not occur by increased metabolism or increased lipid peroxidation, increased covalent bonding, or any number of these putative mechanisms. Then we have to look for a new mechanism and that is why we look for it, and we believe the mechanism is one of interfering biology of the cell. Clearly, having the animal eating food containing chlordecone interferes with that biological process, which is essentially protective mechanism. That, I think, is a completely normal mechanism, whether it stands up to the test that we will pursue in the future or not, certainly it has led us to a new mechanism. I think this is a direct result of the combination toxicology or toxicology of mixtures. Basically, what that concept says then if you want to go a step further, is that you can simply interfere with repair and not have to have additional or greater putative mechanisms to explain toxicity. What I am saying is, it is a new mechanism, a new way of thinking, and I believe that this approach has led to that kind of thinking.

Conolly: I take your point and I think it was well made, but I am not sure that you really answered the question that I was asking. The point you made is that by studying extras we can learn about mechanisms, perhaps from a new approach that we have not taken before, and that is great, because I personally think that is what we need to know about, are mechanisms, but it seems to me that the whole question of mixtures is really out there somewhere in the future until we really know enough about mechanisms that we can start putting them together in complex ways and making predictions about mixture toxicity.

Yang: Rory, I think that is very true, I totally agree with you, from the point of view of our 25-chemical mixtures. Two years ago, I showed an equation on a board – at 33,541,000 or so combinations – so it is impossible you could add everything up, but on the other hand, I am looking from the point of view that we do not know anything about health effects of these things. The first step is that if we show some effect, which we are very surprised to see really, and then maybe the mechanism of such effects may not be just of one chemical, it may be collectively because of physicochemical reasons, that all of those have got to be there. So you can look at it from one point of view that this mixture is actually one compound. Then you can do the mechanistic studies we are interested in doing. Right now, we are doing a study on what is the pretreatment of this chemical mixture having to do with, for example, the pharmacokinetics of carbon tetrachloride, pharmacokinetics of methylene chloride, and you can expand that further to DNA bindings, and that sort of thing. Consider that as a "phenobarbital." Now I am not as pessimistic as you are; in fact, I think if I, in my lifetime, cannot answer this question, somebody later on will. You know, we are just providing a piece of the mosaic. In fact, I am so optimistic that I have talked to Mel Andersen, and I

said "what is the possibility of doing modeling on 25 chemicals with mass balance equations interconnecting all those chemicals together?" and he said "Theoretically, it is do-able," so I am thinking that even down the road maybe we can do some predictions, if we have enough material, knowledge, and so on.

**Anstadt:** May I make one comment? I want to boohoo everything you have just said because I want to talk about something other than binary mixtures, even 25 mixtures of chemicals mixed together, and that is complex mixtures. I think that it is rather hopeless at this point to realistically talk about discovering mechanisms with such complicated mixtures when we cannot understand the mechanisms of just two compounds mixed together that have been studied for 30 years, and I think that it is important to not focus on that question when it comes to complex mixtures, but to get over it, to get on with the business of studying complex mixtures, fractionating them. There have been studies where the fractions have been mixed together in various ways. Reconstituted mixtures have been studied. There has been interesting kinds of synergisms and antagonisms observed from those kind of studies and I must tell you that of all the studies done on interactions in the field of genetic toxicology, after close to 15 or 20 years of work, no first principles yet have been identified and I don't think any are likely to be identified in the near future because of the complexities of the systems, the complexity of the endpoint, and the complexity of the chemical world. I don't think it means we should not keep looking; I think it is very important. But when it comes to real-world complex mixtures, I think that is not exactly a question whose time has come.

**Dr Clay Frederick (Rohm and Haas Company):** What I found particularly pleasing was the discussion of the effects of Vitamin A and also the effects of basically brain-hormone type effects and the relationship to xenobiotic metabolism. The reason is because I think much of the work I have seen on mixtures seems to have been driven by the EPA priority chemicals and the interactions of the halogenated hydrocarbons and all, and I feel like we are running down a narrow road in the study of mixtures and interactions of things. We are basically talking about differences in the interaction of metabolism, either inhibitors of P-450 or enhancement, induction of this activity, but when we start talking about different physiological mechanisms drawn from very different compounds, very different roots, and how they may affect things, I think we may be doing more to reflect the real world. I think if there is one hope, if you will, to the study of the interaction of mixtures, it is to talk about class physiological effects. In other words, materials that may, in fact, induce Kupffer cell activity may be a general effect on other compounds, that may be a general mixture effect. That is the only real hope that I see in understanding this mixture game; otherwise, you are going to have an infinite number of possibilities if we do just mix and match in twos, and threes, and fours, and thousands.

**Anstadt:** If it is any consolation, there are now studies going on in mutagenesis that are mixtures of mixtures and this is the field of antimutagenesis. Obviously, as a lot of you know, extracts of many, many vegetables, especially cruciferous vegetables, contain a lot of antimutagenic activity and so there is now a whole series of studies, mixture studies, combining those extracts with mutagenic complex mixtures, in looking for inhibitions, and they get very complicated.

**Dr James Trosko (Michigan State):** I was recently at an international conference and I would like to share with you something that I think has bearing on Dr Sipes's and Dr Mehendale's and the whole panel's discussion of mixtures and toxic effects. The first thing is we have to remember when we study single chemicals either *in vitro* or in animals, we are really not studying single chemicals, because a single chemical in a tissue culture is interacting with growth factors, which tend to give spurious results from one laboratory to another if they don't use the same lot. And in the animal this may explain why a single chemical, either at a different developmental stage, or different species, or different sex gives different results, because it is interacting with endogenous chemicals that are different at these different stages, tissues, and sexes. But more importantly, I think it gets down to understanding mechanisms. The problem is, if we do not understand mechanisms responsible for single chemicals, how can we understand it in complex mixtures? What are we talking about when we are talking about mechanisms? One speaker talks about mechanisms at the molecular level, DNA repair for example; another is talking about biochemical mechanisms, glutathione scavenging or enzyme induction; another person is talking about cellular mechanisms, or cell-to-cell communication; another is talking about physiological mechanisms like neuroendocrine effects. So we have to be careful of which level of biology we are talking about, not that they are independent of each other, because they are, in a hierarchy, all interrelated, but finally, one mechanism involved in many chemical toxicities is, in fact, disrupting the basis for cellular homeostasis that is necessary in a multicellular organism, namely gap junctional communication. Within that level we now know there are five different mechanisms controlling how a chemical blocks cell-to-cell communication. Having identified those five, it is interesting now that we can determine that a chemical such as phorbol ester blocks gap junctions by activating protein kinases, we know the mechanism. We can then take DDT, which we know blocks gap junction of communication, and we now think we know the mechanism there – it enhances intercellular calcium. Both of these mechanisms block gap junctions; that is, what would be the prediction if we added the two together? Would they be additive, would they be synergistic? We know something about PKC – it is a calcium phospholipid-sensitive enzyme. Therefore, if we add these two chemicals together, they may be synergistic. On the other hand, if you know the mechanism by which this particular phenomenon, gap junction of communication, is effected, you can now do additive studies. Add two chemicals that modulate gap junctions by raising calcium, like DDT and dieldrin, or ketone by the way, and, in fact, you get additivity rather than



synergism. We also now know that there are some chemicals increasing cell-to-cell communication as well as others that block it. A Swedish group at Karolinska added those kinds of chemicals, knowing how each individual chemical modulated gap junction, and they were able to antagonize it.

So what I am saying is that if you identify the level by which the chemical presumably is affecting the toxicology, the mechanism at that level, the cellular and the biochemical, you might now have a chance to get at predictability of these complex mixtures. Finally, as a point of information and a fact that you might be able to run with, Dr Mehendale, it might be interesting to know that when you partially hepatectomize those livers, you are down-regulating gap junctions, and, through the gap junctions, by the way, glutathione can flow back and forth. So by isolating the cells with the partial hepatectomy you down-regulate the gap junctions, and the cells cannot talk to each other; they can neither protect each other nor can they share the damage. My suggestion is, under those studies in which you have observed these kinds of synergisms and protective agents, you look and see what happens to the gap junction. All I am saying is these are different levels by which mechanisms can be studied and I think that you and others up there have studied at different levels but you have not looked at the one that ties the whole organism together, and it is this interaction, which Dr Sipes' work is now clearly pointing to.

**Sipes:** I think that what you have to keep in mind again is the question you are asking: "Is everybody looking for a basic fundamental mechanism?" If everything gets down to that level, fine, but you also want to know what is the triggering event and is the triggering event in the CNS or is it in the Kupffer cell, or is it in the big toe, and just because everything comes down and it effects one of the particular gap junction proteins, in the long run, that is fine, if you know it is a common mechanism. I think you want to know where the initiating event is that results in the interaction; and I think that is the way some of the talks were focused today. And the other thing, talking about complex mixtures, I hope that everyone realizes that you can have things that up-regulate, down-regulate, inhibit, enhance, and that is going to be very complex. In approaching the question head on, for specific hazardous waste sites or whatever, that may be one way to ask the question. I think that I want to underscore what was said. I was involved in some of the Love Canal studies and when they faced it head on and said we are going to expose the animals to this mixture and see what happens, I thought that was a novel way of doing it. Many years ago, people would not have wanted to fund that because we did not know how one chemical worked. These mixtures are going to change, too, and the components in them can change, so it is a tough issue.

**Mehendale:** Thank you, Dr Trosko, for your comments. One, I completely agree with you that you have to go level-by-level to look at the mechanism. In our own case, identifying that there is something wrong with the biology of cell division allows us to reach that one level and therefore open up that cell and look at the molecular biology of why one cell divides and one cell doesn't.

Concerning the gap junction issue, we have not really looked at that; we were aware that the gap junction will be down-regulated or less by partially hepatectomized liver cells. Many of these cells are newly divided and perhaps would not have had the time to double up gap junctions. Glutathione levels in those cells are at or slightly above normal levels – it is only that biochemical reason to be involved – and second, carbon tetrachloride toxicology does not involve decreases of glutathione as a primary event. Later on, as the toxicity progresses, it does. Therefore, that particular biochemical would have something to do with it. Perhaps that is an issue we need to look at in the future. However, what we have done so far allows us now to go into the cell and ask some specific questions and therefore go at another level of mechanisms.

**Dr Bernard Schwetz (NIEHS):** I think there are two important approaches that we as scientists are using to look at this problem of mixtures. One is to look at the toxicity in a descriptive sense of what these mixtures do to animals, but that is an endless process because there is an infinite number of mixtures and it is going to be a real slow process to make much of a dent in that, unless we are really surprised by either the lack of toxicity or a significant toxicity from these mixtures at environmental levels. The other one is what has been well-described today with some very good examples of looking for mechanisms for which these interactions occur. But understanding mechanisms has not been an easy and rapid process. It may take a long time for us to understand the mechanisms of some of these simple mixtures and then begin to understand how they operate at an environmental level, or with other components of mixtures. Because in the meantime we are assuming an additivity model for predicting the toxicity of these mixtures that are out there in the environment, are there some studies that you would conceive being useful that could be tested now to challenge the additive model with mixtures without knowing the mechanism of action or interactions?

**Mr Kurt Enslein (Health Designs Inc.):** One should be daunted by this wide array of varieties of complex mixtures in the environment. When you at least look at the genetic toxicology of the wide array of complex mixtures that have been studied, it turns out that they actually fall into rather interesting, somewhat discrete classes. They are not as diffuse and wide as one would imagine. Combustion emissions tend to fall in a particular potency range in terms of their mutagenic potency and their carcinogenic potency based on mouse skin tumor studies. Certain other kinds of mixtures, such as surface water and drinking water concentrates, tend to also fall within a certain narrow range, usually just two orders of magnitude of mutagenic potency; they have not really been studied for carcinogenic potency yet. And so, although there is a wider range of mixtures out there, they may not be as diverse as one might think. It sheds some ray of hope, I think, in beginning to get a handle on what are the kinds of interactions going on and what are the kinds of differences that we might expect to find between certain types of mixtures. They are not all across the board. They do seem to fall in certain categories.

**Yang:** As one of the most important aspects in terms of involvement of pollution, mixture exposure to people is at low level and long-term. For that, I would like to launch the concept of "promoter" or "enhancer," this is, in a generic sense. Promoter is not limited to carcinogenesis. It could be something that would promote any toxicity. In other words, as I presented this afternoon, you may have a situation where you are exposed to a chemical mixture of some sort. Clinically and by conventional toxicity indices, the animal will be normal, and yet, upon a certain challenge, be it drug intake or accidental exposure, joint toxicity might ensue. That is the kind of study, which, in my view, is very important, and in Dr. Sipes's lecture, he was talking about a combination of events leading toward joint toxicity, and I really like that idea very much. I think it is not just a single mechanism, but it would be a combination of mechanisms toward one common endpoint.

**Mehendale:** Just a brief comment. Suddenly, we already have been doing complex mixtures studies whether we want or not. Diesel exhaust and cigarette smoking are perhaps the two most illustrious examples of mixture toxicology and suddenly those are very important, relevant studies. Some compounds are going to antagonize, some compounds are going to increase, but to some extent it is still an increase, and in this case, increases chances of cancer. Therefore, I think even if we don't get mechanisms – getting at mechanisms is going to be painfully slow – I think we still benefit from doing these studies and the studies will obviously improve as we learn the not-so-optimistic studies we have just completed.

**Dr Ron Wolff (Lilly Laboratories):** I just want to return to what you said in the beginning about keeping an open mind on the subject. I think that is particularly important with complex mixtures and I think I want to share what I think are a couple of insights I gained in some work with James Bond and Joe Moderly at the Lovelace Laboratories before I left, related to diesel exhaust toxicology. We had done work for a number of years using a model system of benzo[a]pyrene inhaled with associated particles and we, along with previously Saffiotti and Nettesheim and others have shown that when these materials were administered to the respiratory tract together, benzo[a]pyrene was retained in the lung for much longer time periods than if it was on carbon particles or other particles, the inference being that longer retention of the material in some way led to greater toxicity. We did all those experiments and then in the last year we looked at DNA adducts after exposure to pure benzo[a]pyrene and benzo[a]pyrene associated with carbon particles to use that as an index of genotoxic damage, and found, as we had before, that the total <sup>14</sup>C label over the 12-week exposure was at least a hundredfold higher when material was associated with particles, but the DNA adduct levels were not different between a pure benzo[a]pyrene exposure and a combined particle exposure. This led us to re-think things a little bit in terms of the realm of carcinogenicity. I think we do need to keep open minds on these complex problems and keep digging at things from the available facts.

**Major John Latendresse (Navy Toxicology Detachment, Wright-Patterson Air Force Base):** I wanted to ask Dr Sipes if there was any particular morphological pattern related to the hepatocellular necrosis in the systems that you studied showing Kupffer cell activation?

**Sipes:** You mean relative to the response to carbon tet itself or just to the Vitamin A?

**Latendresse:** I was just wondering if, with the Kupffer cells actively involved in the damage, does that provide a particular morphologic pattern of degeneration or necrosis in the liver?

**Sipes:** Not that I can tell you. I am certainly not an expert in the area. You are going to hear much more about the role of Kupffer cells in injury. I know there are several people working on this particular area now. In some cases, Kupffer cells become involved because they are recruited into the liver from plasma and they become a resident macrophage and they may be recruited in. It reminds me of some of the work from Rutgers with Debbie Laskin. She is looking at a model where with the acetaminophen she gets no necrosis at 24 h but between 18 to 24 or 36 h there is recruitment of Kupffer cells and then there is probably this oxidative burst that displays the greater hepatotoxicity she sees at 48 h. In our system we are not recruiting, we are activating Kupffer cells. We cannot see any increased number; we do not see an infiltration. So essentially what we see is basically an augmentation of the carbon tetrachloride-induced injury. There may be an underwriting role for the Kupffer cells there that we are just going to start appreciating. I actually had a question for Hari who was talking about the fact that these cells have to divide in his ketone model, that he needs mitosis, and do you have to have clearance of dead cells in order to trigger cell division, do you know? I do not know if I answered your question, but we can see no difference histologically. If you gave a small dose of carbon tet-treated Vitamin A to an animal, and you gave an equivalent dose that would produce the same degree of toxicity of carbon tet, you know a very large dose, with those equivalent degrees, I cannot tell any difference. The only change at the light level that we can see, now that we know that Kupffer cells are activated, is they are more prominent in the sinusoids of even H&E-stained cells, and if you stain specifically they just light up. Or, if you give carbon products or other agents that they will take up, you can see them more readily, but there does not seem to be a large increase. I do not see a marked morphological difference.

**Dr Ugis Bickis (Queens University):** Of course the classic example of promotion of carbon tet hepatotoxicity relates to ethanol, and Dr. Sipes mentioned that this could be due either to the stimulation of Kupffer cells and both the inhibition of Kupffer cells, if I understood correctly, depending upon whether it was an acute dose or a chronic dose. I was wondering if he could reconcile for my benefit how those two factors could both lead to the promotion of the effect, or secondly, how Dr Mehendale's model might also account for the interaction between alcohol and carbon tet?

**Sipes:** I guess what I was trying to say was that what we have been able to find is that if you treat Kupffer cells with ethanol and measure portal blood levels, you have slight activation but as you increase the dose of alcohol to say three or four doses over a two-day period, 4g/kg or something of a pretty large dose, Kupffer cell activity can be decreased. We also are able to show that acetaldehyde severely depresses Kupffer cell function, so I guess what I was trying to say is that if you have a role where you have an activated Kupffer cell that could participate an injury, you could possibly potentiate injury at that stage. If you needed the Kupffer cell there for its normal phagocytic function and it was not functioning and you had endotoxins or other agents that would be coming up from the intestinal tract where you are depending on Kupffer cell function, and they may then reach the liver in much higher concentrations than they would if you had active Kupffer cells and how that would impinge on the liver's function, I don't know. I was just trying to make the issue that it comes back to the same thing with metabolism. In some cases you can protect the liver by enzyme induction and in other cases you can't, if it is an activated species, make the liver more susceptible to injury. The one thing about alcohol is that it has been very clearly shown that it induces a particular P-450 that activates a large number of compounds. We actually tried with our Kupffer cell model with acetone, which we showed a long time ago, that acetone is a potent potentiator of carbon tet injury, we thought that maybe we were getting Kupffer cell effect there, and we tried to block that and it had no effect. We think that the acetone effect is probably coming back to that it is inducing a particular P-450. I think the whole thing is really complex, and I think people working in the alcohol field would probably relate or understand it as a complex issue, and I don't know if people were talking about repair processes and how alcohol could influence that. I should say, I was just talking about acute hepatocellular injury and not even thinking about the long-term consequences of chronic exposure to Vitamin A, for example, which may lead to cirrhosis in its own right or fibrosis, so it was looking very acutely at a response.

**Mehendale:** If I may just briefly respond to that question as it related to some of our work. When we learned about the Kupffer cell activation with acetaminophen, we looked for some indication that perhaps that might be happening with our chlordecone-carbon tet interaction, and we couldn't find any indicators in support of that with that interaction. However, recently we have done some studies where we have taken a homologous series of alcohols and looked at potentiation of carbon tet toxicity. We have not published that work; it will be presented at SOT. The rationale there was when we looked at the literature for a lot of these kinds of studies, save for a few exceptions, people had used rather large doses of alcohol in those interaction studies, where those alcohols themselves were somewhat toxic, either after repeated administration or single administration. We wanted to look at combinations where the alcohol by itself would not be toxic by measures of classic liver injury, and then look at whether carbon tetrachloride toxicity will be enhanced. And the findings are that the

alcohols are falling almost distinctly to two groups. We have not covered all of the structures; we were looking at about 10 different alcohols, starting from one carbon methanol to 20 carbon icosynol. We find that some alcohols increased liver injury under those circumstances, relatively low doses of carbon tet also, and also increased fatalities from it, so if you leave those animals alone, in fact, more numbers go on to die. The other alcohols in the other group increased liver injury but, if you leave them alone, nothing ever happens to those animals. That is intuitive to me that there is something interesting there. Why in both cases is there increased liver injury, but only in some cases the animal will actually go on to die from it, so that is not a reversible process? And in some cases, it is reversible. The reason I pointed these studies out is we have looked at the liver sections and we see a lot of lymphocyte infiltration, much more than we have seen in our carbon tet interaction. We don't know what that means but are interested in those things and what those cells are doing. We are looking at part of the answer to your question.

**Dr Bruce Stuart (A.D. Little):** The question of complex mixtures has been revolving around one of great interest to me and that is diesel engine exhaust. It started with uranium miners back in the mid-60s. Let me just offer the fact that although it is a very complex mixture, if you examine the source term you obtain a mixture that is representative of the real world. This was found in studies that we promoted from the uranium mines analyzing what was actually happening in terms of the ratio of carbon monoxide, particulates, NO<sub>x</sub>, the aldehydes, and aliphatics, and then reforming this by a modified diesel engine in the laboratory, were able to produce lesions within the lung that progressed into vesicular emphysema, sequestration of pulmonary alveolar macrophages in interstitial regions, and set the stage for the later development of pulmonary carcinoma. I mentioned this because other studies done with perfectly operating engines that were not under cycles of load and RPM did not produce the quantities of particulate with associated PAH that are found in the real world.

**Enslin:** There are now five ventilation studies with diesel exhaust and they are very compatible with the short-term bioassay results in terms of the relative carcinogenic potency calculated from them.

**SESSION III**

**EXPERIMENTAL DATA AND CARCINOGENESIS MODELS**

**Dr Rory B. Conolly, Chairman**

## GENETIC DETERMINANTS OF HEPATOCARCINOGENESIS IN THE B6C3F<sub>1</sub> MOUSE

Norman R. Drinkwater, Marie Hanigan, and Christopher J. Kemp

*McArdle Laboratory for Cancer Research, University of Wisconsin, Madison, WI 53706*

### SUMMARY

The B6C3F<sub>1</sub> mouse is highly susceptible to the induction of liver tumors because of the contribution of a specific gene, an allele of the hepatocarcinogen sensitivity (*Hcs*) locus, inherited from its C3H inbred parent. This gene affects the rate of growth of preneoplastic hepatic lesions and results in the more rapid appearance of hepatic neoplasms in mice carrying the C3H allele in comparison to mice homozygous for the resistant C57BL/6 allele. The *Hcs* locus also acts synergistically with at least one class of chemical tumor promoters, the halogenated aromatic hydrocarbons. Because of this genetic promotion of hepatocarcinogenesis, B6C3F<sub>1</sub> mice are more sensitive to liver tumor induction by both genotoxic and nongenotoxic carcinogens.

### INTRODUCTION

The Fischer 344 (F-344) inbred rat and B6C3F<sub>1</sub> hybrid mouse have been widely used as test animals for the determination of the carcinogenic activity of chemicals. The most common response for those chemicals that exhibit carcinogenic activity is the induction of liver tumors. In a recent survey of the results of 222 carcinogen bioassays performed by the National Cancer Institute (NCI) or the National Toxicology Program, Ashby and Tennant [1] indicated that of the 115 chemicals found to be carcinogenic, 62% induced liver tumors in rats and/or mice.

Although the prevalence of hepatocarcinogenic responses is to be expected given the usual oral route of carcinogen exposure and the role of the liver as the primary organ for xenobiotic metabolism [2], the significance of liver tumor induction in treated B6C3F<sub>1</sub> mice as an indicator of potential carcinogenic risk to humans has been questioned [3,4] along three lines. First, although there is a significant association between hepatocarcinogenic activities in the rat and mouse, the concordance is far from perfect. Thus, approximately 60% of the hepatocarcinogens identified in the above survey [1] were active only in the mouse, while 33% were active in both species. Second, for approximately 20% of the carcinogens, the only positive response was the induction of liver tumors in B6C3F<sub>1</sub> mice. Third, the spontaneous incidence of liver tumors in B6C3F<sub>1</sub> mice is relatively high. Ward et al. [5] have reported that among approximately 5,000 B6C3F<sub>1</sub> mice that served as untreated controls for the NCI Carcinogen Bioassay Program, the incidences of liver tumors were 22% for male and 4% for female mice. The second and third points above have led to the suggestion that some



agents may enhance the development of spontaneous liver tumors in B6C3F<sub>1</sub> mice by mechanisms that are unique to mouse liver and are not relevant to the potential for human carcinogenicity [3,4].

The C57BL/6 and C3H inbred parents of the B6C3F<sub>1</sub> mouse differ greatly in their susceptibilities to both spontaneous and chemically induced hepatocarcinogenesis [6-10]. As first reported by Andervont in 1950 [6], the lifetime incidence of liver tumors in untreated C3H male mice may exceed 50%. In contrast, fewer than 4% of male C57BL/6 mice develop liver tumors by two years of age [11]. The relative susceptibilities to induction of liver tumors by carcinogens for male mice of these two strains parallels this difference in spontaneous tumor incidence such that the mean tumor multiplicity in carcinogen-treated C3H mice is greater than that for C57BL/6 mice by from 15 to 50-fold [8,10,12]. It is presumably the genetic contribution of the C3H parent that results in the high sensitivity of the B6C3F<sub>1</sub> mouse to hepatocarcinogenesis.

Our laboratory has focused on the genetic and biological basis for the susceptibility of C3H mice to liver tumor induction, both as a model for the genetic control of carcinogenesis and as an aid to evaluate the significance of the hepatocarcinogenic responses in B6C3F<sub>1</sub> mice obtained in carcinogen bioassays. Our studies [10, 13] have demonstrated that a single genetic locus, which we have denoted *Hcs*, is responsible in large part for the high susceptibility of C3H mice to liver tumor induction. The C3H allele of the *Hcs* locus increases the yield of liver tumors by increasing the growth rates of preneoplastic lesions relative to those in resistant C57BL/6 mice. The semidominant action of this gene makes the heterozygous B6C3F<sub>1</sub> mouse a sensitive and useful indicator for both genotoxic hepatocarcinogens and liver tumor promoters.

#### ***Genetic Analysis of Hepatocarcinogenesis in C3H and C57BL/6 Mice***

In the typical bioassay for carcinogenic activity, the test compound is administered to adult animals in the diet for a period of two years [14] such that multiple carcinogen-dependent events may contribute to tumor induction. Because we are interested in the influence of the genetic background of the host on carcinogenesis, we have used an alternative protocol in which infant mice are treated with a single dose of carcinogen [9]. The rapid proliferation of the hepatocytes during this period results in the efficient fixation of initiating events induced by the carcinogen. The subsequent development of liver tumors depends on the strain and sex of the mice. When one-day-old male mice were treated with *N, N*-diethylnitrosamine (DEN), the liver tumor multiplicities at 32 weeks of age were approximately 50-fold greater for C3H/HeJ mice than for C57BL/6J mice (Figure 1) [10]. At a dose of 0.1  $\mu\text{mol/g}$  body weight, the mean tumor multiplicities were approximately 30 and 0.5 tumors per animal for C3H/HeJ and C57BL/6J mice, respectively, while that for the B6C3F<sub>1</sub> hybrid mice was approximately 15.

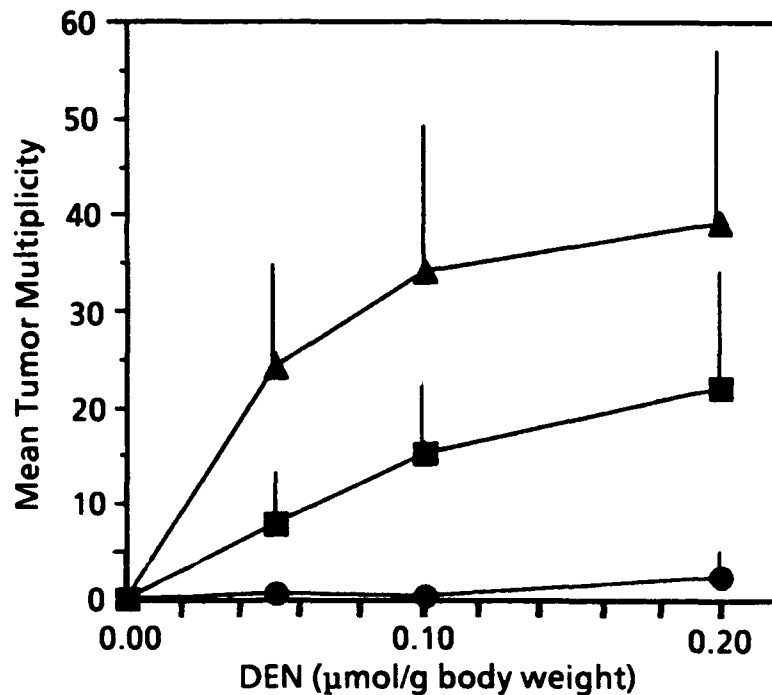


Figure 1. Dose Response for the Induction of Liver Tumors by *N, N*-Diethylnitrosamine (DEN) in C57BL/6J, C3H/H3J, and B6C3F<sub>1</sub> Male Mice. Male mice were treated at one day of age with DEN and sacrificed at 32 weeks of age for enumeration of liver tumors. The mean tumor multiplicities (21 to 37 mice per group) are indicated for C57BL/6J (circles), C3H/HeJ (triangles), and B6C3F<sub>1</sub> (squares) mice. The vertical line associated with each point represents the standard deviation of the liver tumor multiplicity.

One approach to determining the genetic basis for this difference in susceptibility to liver tumor induction is to study the segregation of this phenotype in backcrosses between F<sub>1</sub> and parental inbred mice and in intercrosses between F<sub>1</sub> mice. The number of tumors induced in an individual animal by a standard treatment regimen provides a quantitative measure of its inherent susceptibility. We have analyzed liver tumor induction at 32 weeks of age in 300 male mice, which were obtained in segregating crosses derived from C3H/HeJ and C57BL/6J mice and were treated as newborns with 0.1 μmol DEN [10]. These studies demonstrated that the simplest genetic model that could account for the observed distributions of tumor multiplicities included two independent loci that controlled the sensitivities of the mice to hepatocarcinogenesis. However, one of these genes, which we have designated *Hcs*, accounted for approximately 85% of the greater susceptibility of C3H/HeJ male mice relative to C57BL/6J mice. This locus is autosomal and the C3H and C57BL/6 alleles are semidominant, such that the heterozygous B6C3F<sub>1</sub> mouse is intermediate to the two parental strains in susceptibility.

Recombinant inbred (RI) mouse strains provide an additional approach to the genetic analysis of such complex phenotypes as susceptibility to tumor induction [10,15]. A set of RI strains is derived

from the continued brother-sister inbreeding of independent lines obtained from F<sub>2</sub> cross between inbred parental strains [16]. Each strain in the set has a reproducible recombinant genotype and is homozygous for one of the two parental alleles at each locus. We have compared nine of the available BXH recombinant inbred strains derived from C57BL/6J and C3H/HeJ mice for their sensitivities to the induction of liver tumors by *N*-ethyl-*N*-nitrosourea (ENU) (Table 1) [10]. As expected from the segregation studies, approximately one-half (four of nine) of the strains were as sensitive as C3H/HeJ mice to hepatocarcinogenesis, while the remaining strains displayed the C57BL/6J phenotype (three of nine) or were intermediate in susceptibility (two of nine).

**TABLE 1. INDUCTION OF LIVER TUMORS BY *N*-ETHYL-*N*-NITROSOUREA (ENU) IN C57BL/6J, C3H/HeJ, AND BXH RECOMBINANT INBRED MICE<sup>a</sup>**

Strain	Number of Mice	Liver tumor Multiplicity	Putative <i>Hcs</i> Genotype
C57BL/6J	26	1.1 (2.9) <sup>b</sup>	B <sup>c</sup>
C3H/HeJ	20	22 (14)	H
BXH-6	28	1.9 (2.1)	B
BXH-14	30	2.2 (3.2)	B
BXH-10	22	4.1 (3.8)	B
BXH-4	19	6.3 (5.1)	B
BXH-19	30	12 (11)	B
BXH-8	25	20 (13)	H
BXH-9	25	20 (12)	H
BXH-7	20	23 (15)	H
BXH-3	23	26 (10)	H

<sup>a</sup> Male 12-day-old mice were treated with 0.5 μmol *N*-ethyl-*N*-nitrosourea/g body weight and liver tumors were enumerated at 32 weeks of age. See Drinkwater and Ginsler, 1986 [10] for further details.

<sup>b</sup> Values are mean (standard deviation).

<sup>c</sup> B and H refer to the C57BL/6J and C3H/HeJ alleles, respectively.

The genetic studies described above are directly relevant to the chemical induction of liver tumors in male mice, and do not provide a genetic basis for differences between the two inbred strains in the spontaneous incidence of liver tumors in male mice or in the susceptibilities of female mice to hepatocarcinogenesis. As noted above, C3H male mice exhibit a substantially higher spontaneous incidence of liver tumors relative to C57BL/6 mice. Although female mice of all inbred strains tested are significantly less sensitive to liver tumor induction than are male mice [12], the

multiplicities of carcinogen-induced liver tumors in C3H/HeJ female mice was 3- to 15-fold greater than that for C57BL/6J female mice, depending on the age of the animals at sacrifice [unpublished observations of Kemp, Winkler, and Drinkwater]. We are currently determining the incidences of spontaneous liver tumors in male mice of the BXH recombinant inbred strains and the susceptibilities of female mice of these strains to chemically induced hepatocarcinogenesis. If the *Hcs* locus is the primary determinant of strain variation for these two additional phenotypes, their strain distribution patterns should be identical to that determined previously for the induction of liver tumors in male mice.

### ***Mechanism of Action of the Hcs Gene***

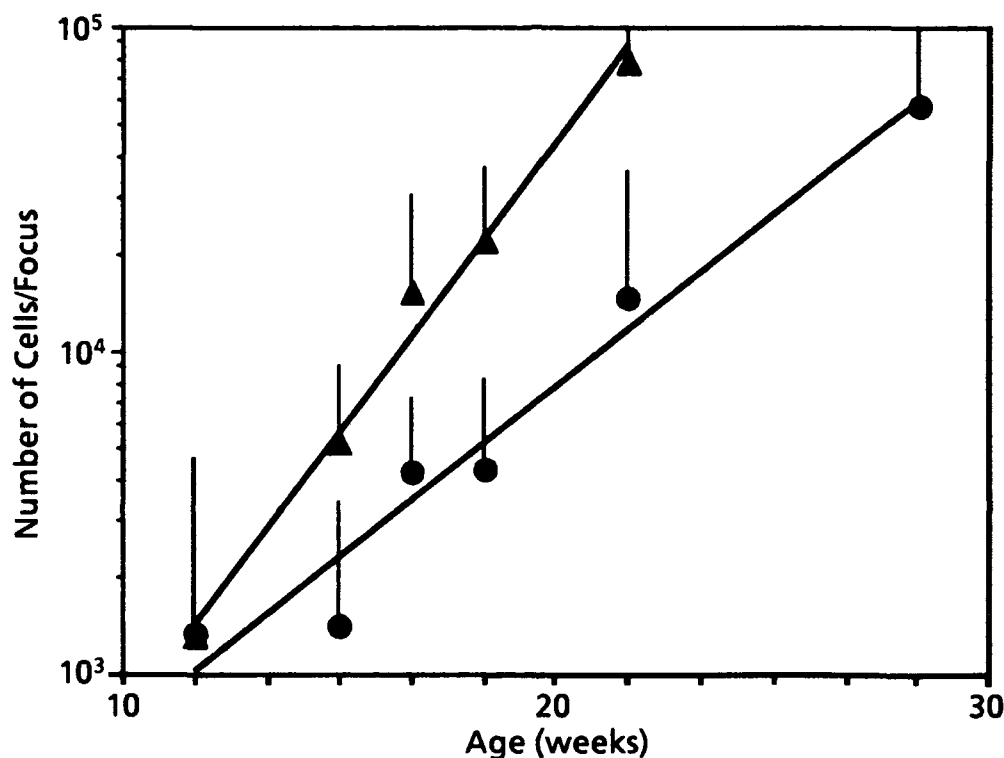
C3H mice are more susceptible than C57BL/6 mice to hepatocarcinogenesis by a variety of agents [12], and these two strains are similar in the levels of hepatic DNA modification observed after carcinogen treatment [8,10]. These observations are consistent with a model in which the *Hcs* gene influences post-initiation events during carcinogenesis. This hypothesis can be tested directly by analysis of the development of preneoplastic hepatic lesions in carcinogen-treated C3H and C57BL/6 mice.

Prior to the development of tumors, focal lesions of hepatocytes with altered histochemical staining properties are observed in the livers of carcinogen-treated rodents [17-19]. In the mouse, these lesions may exhibit a variety of phenotypic alterations, including increased glycogen storage or RNA levels and decreased adenosine triphosphatase, iron accumulation, or glucose-6-phosphatase (G6P-ase), with the reduction in G6P-ase activity as the most consistent observation [18]. Several lines of evidence indicate that these hepatic foci are preneoplastic: (1) There is a close correlation between the development of the altered hepatic foci and the eventual development of hepatic adenomas and carcinomas; (2) the histochemical properties of the neoplasms are similar to those of the hepatic foci; and (3) the hepatic foci grow progressively and demonstrate substantially increased levels of DNA synthesis relative to the surrounding normal liver [13].

Both the number of hepatic foci and their size distribution can be quantified by stereological methods [20]. Analysis of the development of histochemically altered hepatic foci allows the discrimination of the effects of specific treatments on the initiation and promotion phases of hepatocarcinogenesis. For example, the effective dose of initiating agent determines the number of hepatic foci but has little effect on the size distribution of the lesions [17]. In contrast, treatment with promoting agents results in an increase in the size and rate of growth of the hepatic foci [21].

We have compared the kinetics for the development of G6P-ase-deficient hepatic foci in male C3H/HeJ and C57BL/6J mice treated at 12 days of age with ENU [13]. The most striking difference between the two strains was in the rate of growth of the hepatic foci (Figure 2). Between 12 and 32

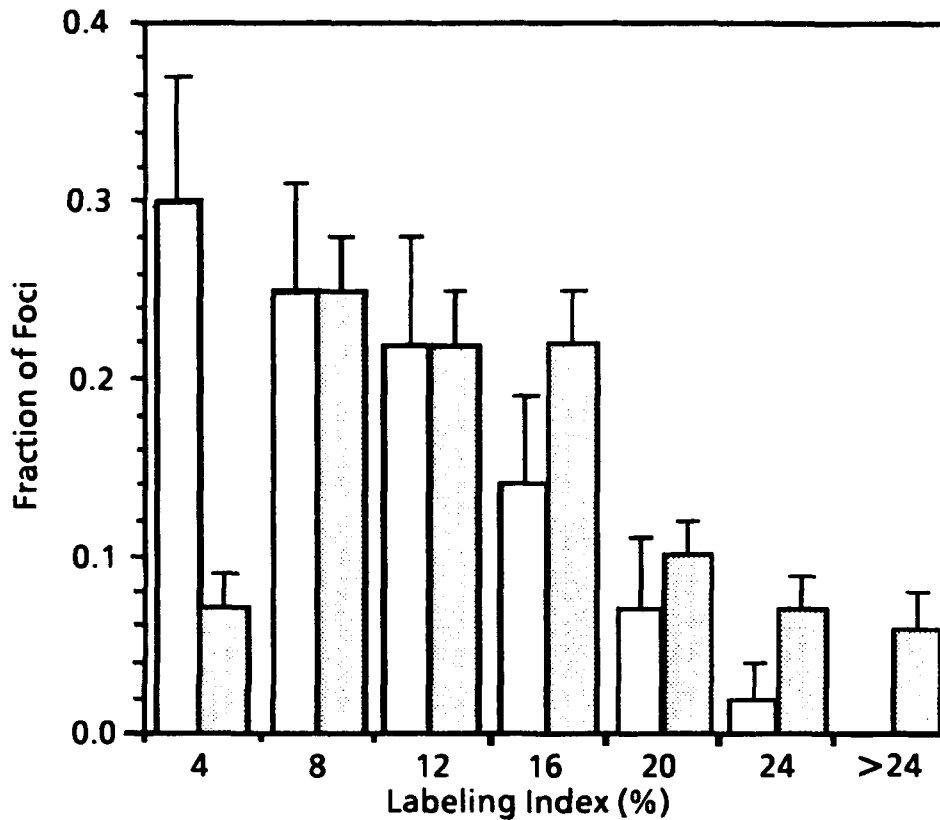
weeks of age, the apparent volume doubling time for the G6P-ase-deficient foci in male C3H/HeJ mice was  $2.0 \pm 0.1$  weeks, while that for C57BL/6J mice was  $3.4 \pm 0.4$  weeks. The volume doubling time for the foci in B6C3F<sub>1</sub> mice was  $2.1 \pm 0.3$  weeks (data not shown). The 70% increase in the rate of growth of hepatic foci in C3H/HeJ mice relative to C57BL/6J mice has an exponential effect on the appearance of the large lesions that are presumed to be the immediate precursors of liver tumors. This difference in growth rate is sufficient to account for the observed differences in tumor multiplicities between the two strains [13].



**Figure 2. Growth Kinetics of Preneoplastic Hepatic Foci in Male Mice.** Male mice were treated with *N*-ethyl-*N*-nitrosourea ( $0.5 \mu\text{mol/g}$  body weight) at 12 days of age and sacrificed at the indicated times for analysis of G6P-ase-deficient hepatic foci. (See Hanigan, et. al. 1988 [13] for further details.) The mean numbers of cells/focus are indicated for C57BL/6J (●) and C3H/HeJ (▲) mice. The vertical bar attached to each point represents the standard deviation.

Data obtained by analysis of <sup>3</sup>H-thymidine labeling of preneoplastic lesions in C3H and C57BL/6 mice were consistent with the stereological measurements of the growth rates of the foci for the two strains [13]. Thus, the proportion of cells undergoing DNA synthesis in the foci of C3H/HeJ male mice was significantly greater than that for C57BL/6J mice (Figure 3, Table 2). For male C3H/HeJ mice at 20 weeks of age, the mean labeling index for the G6P-ase-deficient foci was 12%; 45% of the foci had labeling indices greater than 12% under the conditions of this experiment. For C57BL/6J male mice,

the mean number of labeled cells per focus was 8.3% and the labeling index exceeded 12% for only 23% of the lesions.



**Figure 3.** Distribution of  $^3\text{H}$ -Thymidine Labeling Indices for Preneoplastic Hepatic Lesions in C57BL/6J and C3H/HeJ Male Mice. The data presented in the figure are for G6P-ase-deficient hepatic foci at 20 weeks of age from the experiment described in Table 2. The proportion of foci in each labeling class are represented by white (C57BL/6J) or shaded (C3H/HeJ) bars. The vertical line associated with each bar indicates the standard deviation.

**TABLE 2.**  $^3\text{H}$ -THYMIDINE LABELING OF PRENEOPLASTIC HEPATIC FOCI IN C57BL/6J AND C3H/HeJ MALE MICE<sup>a</sup>

Strain	Number of Mice	Age (wks)	Labeling Index (%)
C57BL/6J	8	20	8.3 ± 2.0 <sup>b</sup>
	12	28	9.5 ± 2.5
C3H/HeJ	11	20	12 ± 2
	11	28	11 ± 2

<sup>a</sup> Male mice were treated at 12 days of age with *N,N*-diethylnitrosamine (0.2  $\mu\text{mol/g}$  body weight). Each animal received six ip injections of  $^3\text{H}$ -thymidine beginning 33 h prior to sacrifice. The labeling index is the average proportion of cells within G6P-ase-deficient hepatic foci demonstrating significant nuclear incorporation of  $^3\text{H}$ -thymidine as determined by autoradiography. See Hanigan et al. 1988 [13] for further details.

<sup>b</sup> Values are mean ± standard error of the mean.

### ***Significance of the Hcs Gene for Carcinogen Bioassay***

A large proportion of both spontaneous and chemically induced liver tumors obtained in B6C3F<sub>1</sub> mice carry mutant alleles of the c-Ha-ras gene [22-24]. In the case of the induced neoplasms, the observation that the sequence of the mutant gene depended on the structure of the carcinogen indicates that these mutations represented initiating events for hepatocarcinogenesis [23, 24]. Based on the studies described above, the presence of a single copy of the C3H allele of the *Hcs* locus in the B6C3F<sub>1</sub> mouse would greatly increase the likelihood that an initiated hepatocyte would give rise to a liver tumor by increasing its rate of proliferation. Thus, this hybrid provides a sensitive test animal for the detection of genotoxic carcinogens. Studies by Wiseman and co-workers [25] and studies in other laboratories [9,10] have demonstrated that single treatment of infant male B6C3F<sub>1</sub> mice with a broad variety of agents is sufficient to induce liver tumors. These agents, which span a more than 300-fold range in potency, included polycyclic hydrocarbons, aromatic amines and amides, dialkylnitrosamines, alkylating agents, alkenylbenzenes, and other classes of carcinogens. This collection of agents contains members that undergo quite different pathways of metabolic activation and give rise to a broad spectrum of DNA adducts.

The efficient detection of genotoxic compounds as hepatic carcinogens in the B6C3F<sub>1</sub> mouse is also reflected by the results of the two-year chronic bioassay. In the survey by Ashby and Tennant [1] discussed in the Introduction, 80% of the compounds classified as genotoxic induced tumors in either B6C3F<sub>1</sub> mice or F-344 rats at one or more sites. Of these genotoxic carcinogens, approximately 60% significantly increased the incidence of liver tumors in B6C3F<sub>1</sub> mice.

Although the above argument provides a reasonable rationale for the sensitivity of the B6C3F<sub>1</sub> mouse to hepatocarcinogenesis by genotoxic carcinogens, the significance of mouse liver tumors induced by nongenotoxic agents is more difficult to evaluate. Among the 54 nongenotoxic carcinogens identified by Ashby and Tennant [1], approximately 60% induced liver tumors in B6C3F<sub>1</sub> mice; this was the only carcinogenic response for slightly less than one-third of the chemicals. One hypothesis regarding the mechanism of action of this class of carcinogens is that they act as hepatic tumor promoters by increasing the rate of proliferation of hepatocytes in treated mice [26,27]. Recent studies from our laboratory in collaboration with Dr. Alan Poland have demonstrated that the *Hcs* gene acts synergistically with promoters of liver tumor induction.

Previous studies have demonstrated that 2,3,7,8-tetrachlorodibenzodioxin (TCDD) and other halogenated aromatic hydrocarbons are potent promoters of liver tumor induction in rats [21,28]. The biological effects of these agents depends on their abilities to bind to a specific high affinity receptor (the aromatic hydrocarbon or TCDD receptor) in the target tissues [29]. We have compared C3H/HeJ and C57BL/6J mice for their sensitivities to promotion of ENU-induced hepatocarcinogenesis

by a TCDD cogener, 3,4,5,3',4'5'-hexabromobiphenyl (HBB) (Table 3). Male mice were treated with a single dose of ENU at 12 days of age and received a single injection of HBB (or the solvent vehicle) at 10 weeks of age. Because of the extremely long biological half-life of HBB [30], this single application results in chronic exposure of the treated mice to low levels of the halogenated aromatic compound. The animals were sacrificed at 32 weeks of age for analysis of tumor induction. The multiplicity of liver tumors induced in C57BL/6J mice treated with 0.5  $\mu\text{mol}$  ENU/g body weight was increased approximately twofold by treatment with HBB, from an average of 6 tumors per animal to 11. C3H/HeJ mice treated with 0.0625  $\mu\text{mol}$  ENU/g body weight developed a mean liver tumor multiplicity of 2.8, while those animals that received both ENU and HBB averaged 11 tumors/mouse, an increase of approximately fourfold.

TABLE 3. PROMOTION OF LIVER TUMOR INDUCTION BY HBB<sup>a</sup>

Strain	Number of Mice	ENU ( $\mu\text{mol/g}$ )	HBB ( $\mu\text{g/g}$ )	Liver Tumor Multiplicity
<b>Experiment 1</b>				
C57BL/6J	24	0.5	0	5.9 (6.7) <sup>b</sup>
	21	0	20	0
	21	0.5	20	11 (10)
<b>Experiment 2</b>				
C3H/HeJ	22	0.0625	0	2.8 (2.9)
	17	0	20	0.2 (0.4)
	30	0.0625	20	11 (10)

<sup>a</sup> Male mice received a single injection of *N*-ethyl-*N*-nitrosourea at 12 days of age and were treated with a single dose of HBB at 10 weeks of age. The multiplicity of liver tumors was determined at 32 weeks.

<sup>b</sup> Values are mean (standard deviation).

These results indicate that promotion of liver tumor induction by halogenated aromatic compounds occurs independently of the genetic promotion of hepatocarcinogenesis by the *Hcs* gene. In the context of the carcinogen bioassay, it may be expected that chronic treatment with liver tumor promoters would result in the appearance of tumors derived from cells initiated spontaneously by errors in DNA replication or by unintended exposure to low levels of mutagens in the diet. In the B6C3F<sub>1</sub> mouse, the efficiency of liver tumor development from these spontaneous lesions would be greatly increased by the *Hcs* gene. Thus, the genetic promotion of hepatocarcinogenesis by the *Hcs*



gene renders the B6C3F<sub>1</sub> hybrid mouse susceptible to liver tumor induction by both nongenotoxic and genotoxic carcinogens.

#### ACKNOWLEDGMENTS

We are grateful to Julie Ginsler and Mary Winkler for their excellent technical assistance. This work was supported by grants CA07175, CA22484, and CA09020 from the National Cancer Institute.

#### REFERENCES

- 1 Ashby, J. and Tennant, R.W. (1988) Chemical structure, Salmonella mutagenicity and extent of carcinogenicity as indicators of genotoxic carcinogenesis among 222 chemicals tested in rodents by the U.S. NCI/NTP. *Muta. Res.* 204, 17-115.
- 2 Haseman, J.K., Crawford, D.D., Huff, J.E., Boorman, G.A. and McConnell, E.E. (1984) Results from 86 two-year carcinogenicity studies by the National Toxicology Program. *J. Toxicol. Environ. Health* 14, 621-639.
- 3 Tomatis, L., Partensky, C. and Montesano, R. (1973) The predictive value of mouse liver tumor induction in carcinogenicity testing – a literature survey. *Int. J. Cancer* 12, 1-20.
- 4 Doull, J. (1983) The Relevance of Mouse Liver Hepatoma to Human Carcinogenic Risk. A report of the International Expert Advisory Committee, The Nutrition Foundation, Washington, DC.
- 5 Ward, J.M., Goodman, D.G., Squire, R.A., Chu, K.C. and Linhart, M.S. (1979) Neoplastic and non-neoplastic lesions in aging (C57BL/6N x C3H/HeN)F<sub>1</sub> (B6C3F<sub>1</sub>) mice. *J. Natl. Cancer Inst.* 63, 849-854.
- 6 Andervont, H.B. (1950) Studies on the occurrence of spontaneous hepatomas in mice of strains C3H and CBA. *J. Natl. Cancer Inst.* 11, 581-592.
- 7 Heston, W.E., Vlahakis, G. and Deringer, M.K. (1960) High incidence of spontaneous hepatomas and the increase of this incidence with urethan in C3H, C3Hf and C3He male mice. *J. Natl. Cancer Inst.* 24, 425-435.
- 8 Delclos, K.B., Tarpley, W.G., Miller, E.C. and Miller, J.A. (1984) 4-Aminoazobenzene and *N,N*-dimethyl-4-aminoazobenzene as equipotent hepatic carcinogens in male C57BL/6 x C3H/He F<sub>1</sub> mice and characterization of *N*-(deoxyguanosin-8-yl)-4-aminoazobenzene as the major persistent hepatic DNA-bound dye in these mice. *Cancer Res.* 44, 2540-2550.
- 9 Vesselinovitch, S.D., Rao, K.V.N. and Mihailovich, N. (1979) Neoplastic response of mouse tissues during perinatal age periods and its significance in chemical carcinogenesis. *J. Natl. Cancer Inst. Monograph*, 51, 239-250.
- 10 Drinkwater, N.R. and Ginsler, J.J. (1986) Genetic control of hepatocarcinogenesis in C57BL/6J and C3H/HeJ inbred mice. *Carcinogenesis* 7, 1701-1707.
- 11 Frith, C.H. and Wiley, L. (1982) Spontaneous hepatocellular neoplasms and hepatic hemangiosarcomas in several strains of mice. *Lab. Anim. Sci.* 32, 157-162.

- 12 Drinkwater, N.R. (1989) Genetic control of hepatocarcinogenesis in inbred mice. In: N.H. Colburn (Ed.), *Gene and Signal Transduction in Multistage Carcinogenesis*, Marcel Dekker, New York, pp. 3-17.
- 13 Hanigan, M.H., Kemp, C.J., Ginsler, J.J. and Drinkwater, N.R. (1988) Rapid growth of preneoplastic lesions in hepatocarcinogen-sensitive C3H/HeJ male mice relative to C57BL/6J male mice. *Carcinogenesis* 9, 885-890.
- 14 Milman, H.A. and Weisburger, E.K. (1985) *Handbook of Carcinogen Testing*. Noyes, Park Ridge, NJ.
- 15 Malkinson, A.M., Nesbitt, M.N. and Skamene, E. (1985) Susceptibility to urethan-induced pulmonary adenomas between A/J and C57BL/6J mice: Use of AXB and BXA recombinant inbred lines indicating a three-locus genetic model. *J. Natl. Cancer Inst.* 75, 971-974.
- 16 Bailey, D.W. (1971) Recombinant-inbred strains, an aid to finding identity, linkage, and function of histocompatibility and other genes. *Transplantation* 11, 325-327.
- 17 Vesselinovitch, S.D. and Mihailovich, N. (1983) Kinetics of diethylnitrosamine hepatocarcinogenesis in the infant mouse. *Cancer Res.* 43, 4253-4259.
- 18 Vesselinovitch, S.D., Hacker, H.J. and Bannasch, P. (1985) Histochemical characterization of focal hepatic lesions induced by single diethylnitrosamine treatment in infant mice. *Cancer Res.* 45, 2774-2780.
- 19 Moore, M.R., Drinkwater, N.R., Miller, E.C., Miller, J.A. and Pitot, H.C. (1981) Quantitative analysis of the time-dependent development of glucose-6-phosphatase-deficient foci in the livers of mice treated neonatally with diethylnitrosamine. *Cancer Res.* 41, 1585-1593.
- 20 Campbell, H.A., Pitot, H.C., Potter, V.R. and Laishes, B.A. (1982) Application of quantitative stereology to the evaluation of enzyme-altered foci in rat liver. *Cancer Res.* 42, 465-472.
- 21 Pitot, H.C., Goldsworthy, T., Campbell, H.A. and Poland, A. (1980) Quantitative evaluation of the promotion by 2,3,7,8-tetrachlorodibenzo-*p*-dioxin of hepatocarcinogenesis from diethylnitrosamine. *Cancer Res.* 40, 3616-3620.
- 22 Reynolds, S.H., Stowers, S.J., Maronpot, R.R., Anderson, M.W. and Aaronson, S.A. (1986) Detection and identification of activation oncogenes in spontaneously occurring benign and malignant hepatocellular tumors of the B6C3F<sub>1</sub> mouse. *Proc. Natl. Acad. Sci. USA* 86, 33-37.
- 23 Wiseman, R.W., Stowers, S.J., Miller, E.C., Anderson, M.W., and Miller, J.A. (1986) Activating mutations of the c-Ha-ras protooncogene in chemically induced hepatomas of the male B6C3F<sub>1</sub> mouse. *Proc. Natl. Acad. Sci. USA* 83, 5825-5829.
- 24 Reynolds, S.H., Stowers, S.J., Patterson, R.M., Maronpot, R.R., Aaronson, S.A. and Anderson, M.W. (1987) Activated oncogenes in B6C3F<sub>1</sub> mouse liver tumors: Implications for risk assessment. *Science* 237, 1309-1316.
- 25 Wiseman, R.W., Miller, E.C., Miller, J.A. and Liem, A. (1987) Structure-activity studies of the hepatocarcinogenicities of alkenylbenzene derivatives related to estragole and safrole on administration to preweanling male C57BL/6J x C3H/H3J F<sub>1</sub> mice. *Cancer Res.* 47, 2275-2283.

- 26 Schulte-Hermann, R., Schuppler, J., Ohde, G. and Timmermann-Trosiener, I. (1982) Effect of tumor promoters on proliferation of putative preneoplastic cells in rat liver. In: E. Hecker, N. Fusenig, W. Kunz, F. Marks, and H. Thielman (Eds.), *Carcinogenesis*, Vol. 7, Raven Press, New York, pp. 99-104.
- 27 Mirsalis, J.C., Tyson, C.K., Loh, E.N., Steinmetz, K.L., Bakke, J.P., Hamilton, C.M., Spak, D.J. and Spalding, J.W. (1985) Induction of hepatic cell proliferation and unscheduled DNA synthesis in mouse hepatocytes following *in vivo* treatment. *Carcinogenesis* 6, 1521-1524.
- 28 Jensen, R.K., Sleight, S.D., Goodman, J.I., Aust, S.D. and Trosko, J.E. (1982) Polybrominated biphenyls as promoters in experimental hepatocarcinogenesis in rats. *Carcinogenesis* 3, 1183-1186.
- 29 Poland, A. and J. Knutson (1982) 2,3,7,8-Tetrachlorodibenzo-*p*-dioxin and related halogenated aromatic hydrocarbons: Examination of the mechanism of toxicity. *Ann. Rev. Pharmacol. Toxicol.* 2, 517-554.
- 30 Miceli, J.N. and Marko, B.H. (1981) Time distribution and elimination kinetics of polybrominated biphenyls (PBB) from rat tissue. *Toxicol. Lett.* 9, 315-320.

## THE SEQUENTIAL DEVELOPMENT OF CANCER: A MORPHOLOGIC PERSPECTIVE

Scot L. Eustis

*National Institute of Environmental Health Sciences, P.O. Box 12233,  
Research Triangle Park, NC 27709*

### SUMMARY

Cancer development proceeds through sequential or contemporaneous morphological changes from normal, preneoplastic, and premalignant lesions to highly malignant neoplasms. The morphological continuum that comprises cancer development is usually divided into diagnostic categories of hyperplasia (or dysplasia), benign neoplasia, and malignant neoplasia based on perceived biological behavior. Although a morphological continuum may be evident from the histologic evaluation of preneoplastic and neoplastic lesions, it is not axiomatic that all preneoplastic or benign lesions progress. The probability of regression or progression from one category to another, or the rates at which these might occur are seldom known for spontaneous or induced neoplasms. Host factors as well as exogenous stimuli may influence these events. The concept of neoplastic progression and the limitations of our knowledge of the biologic behavior of preneoplastic lesions and benign neoplasms are important considerations in the interpretation of pathology data from carcinogenicity studies.

### THE SEQUENTIAL DEVELOPMENT OF CANCER

The primary basis of many investigations into the causation or development of cancer is pathology, particularly the histopathological evaluation of tissue sections. Supplemental diagnostic procedures such as immunohistochemical stains for tumor-associated antigens and electron microscopy are sometimes useful for identifying the type or origin of neoplasms. Although sophisticated molecular or biochemical techniques such as the identification of oncogenes also are used to study neoplasms, these are usually correlated with the histopathological diagnosis for interpretation of the results. Thus, it is important for investigators who are not pathologists to understand the concept of neoplastic progression from a morphological point of view and to have an appreciation for the limitations of our knowledge concerning the biological behavior of lesions that comprise the neoplastic progression. The purpose of the following discussion is to give a morphological perspective on neoplastic progression.

To clearly place into context the published information on cancer biology and to understand the process of neoplasia, it is helpful to have an appreciation for the historical development of our concept of cancer. The definitions that formulate our concepts and the terminology used to classify neoplasms have their origin in classical Greek and were later modified and extended with the

development of the cell theory of body structure [1]. Although categorizations, classification schemes, and definitions provide a necessary framework for the communication of concepts and ideas, this rigid framework guides our thinking and often poses a barrier to objective reasoning.

The most obvious example is the commonly held notion that proliferative lesions (abnormalities of tissue growth) can be clearly and unambiguously categorized as nonneoplastic (hyperplasia or dysplasia), benign neoplasia, or malignant neoplasia. The distinction between benign and malignant neoplasms arose from clinical observations of patient response to surgical treatment long before the advent of the light microscope and development of the cell theory [1]. Certain tumors (used here in the literal sense as any mass or enlargement) were amenable to surgical removal and did not grow back; the prognosis for these patients was good and, therefore, these tumors were considered benign. Other tumors were known to have a poor prognosis. The latter either grew back following surgery or killed the patient from metastases; these were called malignant tumors. With the development of the cell theory and application of the microscope to the study of neoplasms, histological criteria were developed correlating their morphologic appearance with clinical behavior.

More recently, technological advancements in cell biology, molecular biology, and genetics have been applied to the study of neoplasia. More often than not, the results from these studies have been correlated with a histological diagnosis, thereby reinforcing the categorizations formulated over a century ago (e.g., definitions of nonneoplastic proliferation or hyperplasia, benign neoplasia, and malignant neoplasia). The weakness in this historical thought process is obvious; nearly all sophisticated observations on the biology of neoplasia have been collected after the definitions and concepts were established and deeply ingrained in medical usage. The discussion above is not meant to imply that categorizing neoplasms as benign or malignant has no practical utility or that "older" concepts of neoplasia are of necessity invalid. It is meant only to show that one has to recognize the limitations of our terminology, definitions, and concepts when interpreting the results of a particular experiment.

It is important to remember that the categorization of proliferative lesions as hyperplasia, benign neoplasia, or malignant neoplasia is based on the morphological evidence from the microscopic examination of tissue specimens, of autonomous growth (or lack thereof). Neoplasia has been defined as "an abnormal mass of tissue, the growth of which exceeds and is uncoordinated with that of normal tissues" [2]. The basis for making a histological diagnosis is the cumulative experience of correlating cellular and tissue morphology with biological behavior of spontaneous and experimentally induced neoplasms. Except for highly malignant neoplasms which have extensively invaded surrounding structures, the process of making a diagnosis is a "predictive" one, with all of the limitations inherent in the process. Neoplasms are diagnosed as benign if morphological features of the growth at the time of tissue sampling, or previous clinical experience with the growth, indicate

no or relatively minimal potential for malignant behavior. Neoplasms are diagnosed as malignant if malignant potential is demonstrated by actual invasiveness or metastases, or if the growth has histological features that correlate well with the ability to invade or metastasize as demonstrated by other neoplasms of similar histogenesis.

Benign and malignant are convenient terms for defining the relative biological behavior, but it also is important to recognize that not all tissue growths or neoplasms have the same degree of benign or malignant behavior. Malignancy is usually defined by evidence of invasion or metastasis. However, some tumors are minimally invasive and others are extremely destructive to surrounding tissue. Some neoplasms metastasize widely, others may metastasize only to regional lymph nodes or to the lungs or not at all. Also, the ability of a neoplasm to invade surrounding tissue does not necessarily always correlate with the ability to metastasize. For example, basal cell carcinomas of the skin in humans can be extremely invasive and destructive of the surrounding tissues, but rarely metastasize [3]. On the other hand, malignant melanomas of the skin may metastasize widely to the lungs, brain, liver, and other organs when the primary tumor is extremely small and demonstrates little invasion of the surrounding tissue [3].

There are several important points to remember about these categories or definitions. First, these are "operational" definitions based on an evaluation of the lesion at a point in time. Obviously, there is no way to absolutely predict the future of a lesion, unless it is already a cancer that has metastasized. We know from the work with several model systems of carcinogenesis that any individual lesion will have a certain probability of regression or progression, but each is diagnosed according to the perceived biologic behavior when it is examined microscopically. Second, benign and malignant simply define different stages of the spectrum of biological behavior. However, the biological behavior of a proliferative lesion is the result of a summation of a large number of individual variable characteristics that can occur in an infinite number of combinations through alterations in genetic or epigenetic control. Thus, although the categorization of proliferative lesions as hyperplasia (dysplasia), benign neoplasia, or malignant neoplasia has considerable practical utility from a medical perspective, it is, nevertheless, a rather extreme simplification of a complex pathological process.

The concept that cancer development (e.g., malignant neoplasia) is a multistep process resulting in the progressive acquisition of heritable cellular changes (biochemical, functional, morphological) has been promulgated more recently [4-7]. The most comprehensive review of the changes in cellular morphology and behavior that occur during this process was published in a two volume, "Neoplastic Development," by Dr Leslie Foulds [4,5]. There is abundant clinical and morphological evidence that neoplasms become progressively more aggressive and malignant with time, a process called tumor progression. With time there is a tendency for neoplastic cell

populations to increase their proliferative capacity (an increase in the proportion of cells that continue to proliferate actively instead of progressing to terminal differentiation or cell death), show morphological and metabolic alterations indicative of loss of differentiation, and produce substances that may help the neoplastic cell to invade or metastasize, such as angiogenic factor [8] and various proteolytic enzymes [9,10]. A number of investigators have suggested that the events that comprise tumor progression represent the effects of genetic instability and the sequential selection of variant subpopulations of tumor cells with selective-growth advantage [11,12].

The principal observation providing the basis for the concept of tumor progression is that of tumor heterogeneity. Phenotypic and functional heterogeneity not only occurs in histogenically similar neoplasms from different individuals, but also within a single neoplasm from one individual [13]. This heterogeneity is manifested by variable histological growth patterns, variable cell differentiation, and different rates of growth. At the level of functional differentiation, neoplastic cells exhibit variation in their ability to produce hormones (endocrine neoplasms) or other secretory products (exocrine gland neoplasms) [13]. Heterogeneity of enzymatic activity is seen in hepatocellular neoplasia [14]. In addition, the concept of heterogeneity has been shown to include other properties such as karyotype, growth rate, DNA content, drug resistance, metastatic potential, and cell surface antigenicity [12,13].

The main difficulty in studying sequential neoplastic development (for most organs) is the inability to follow morphological changes occurring over the lifetime of the animal with a particular neoplasm. The light or electron microscopic examination of a lesion or neoplasm requires its removal in part or in whole. In humans or domestic animals the health and welfare of the individual are of primary importance and neoplasms are usually surgically removed as soon as they are discovered. In laboratory animals the neoplasms are often so small that to sample them microscopically requires complete excision of the lesion preventing sequential morphological study, or they are not detectable until the neoplasm is far advanced in development. Nevertheless, there are extensive clinical and pathological observations on the biology of several human neoplasms including skin, mammary, cervical, and colon cancer. There is also a substantial amount of information on certain chemically induced neoplasms in laboratory rodents, particularly of the skin and liver.

It has been possible to collect and classify a variety of individual lesions that can be arranged (albeit empirically) in an apparently continuous series of increasing neoplastic potential (e.g., potential for demonstrating biological characteristics of neoplasia). These led Foulds to develop the following general concept of neoplastic development (tumor progression) [4]. He proposed that "initiation establishes a region of incipient neoplasia whose neoplastic capacity [potential for expressing the various biological characteristics of neoplasia] increases with time, with or without

prolongation of the initiating stimulus, and from which varied lesions emerge concurrently or consecutively over a substantial period of time [4,5].”

The earliest lesions to emerge have often been called “preneoplastic” lesions. These are lesions that are thought to be precursors of neoplasia. Stated in another way, these are lesions in which the probability of neoplasia arising is greater than that of neoplasia arising in normal tissue. These lesions can be grouped simply as hyperplasia or dysplasia. Hyperplasia is defined morphologically as an increase in the number of normal cells in normal arrangement within any particular tissue [15]. The important morphological aspects of this definition are that the growth pattern and maturation sequence of the cells are normal (Figures 1,2). It is also important to remember that hyperplasia can occur as a regenerative or reparative response to cellular degeneration and necrosis, or as a response to hormonal stimulation. Hyperplasia from these causes is generally not considered preneoplastic. Atypical hyperplasia is a term sometimes used to indicate that cellular atypia, altered growth pattern, or altered cell differentiation is a component of the hyperplasia (Figures 3,4).

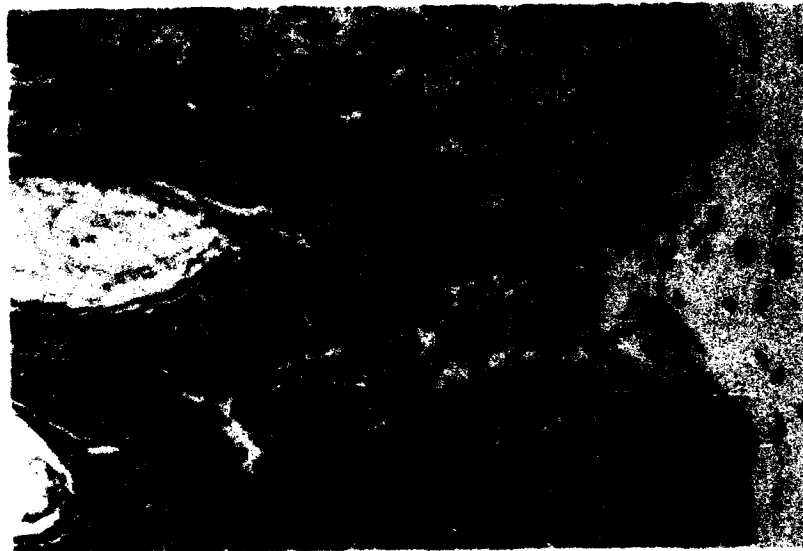


Figure 1. Forestomach of a Rat. Note the thin layer of stratified squamous epithelium (E) overlying the submucosa (S) and tunica muscularis (M).





**Figure 2. Hyperplasia of the Forestomach Epithelium (E).** Note the thickened and folded stratified squamous epithelium.



**Figure 3. High Magnification of Hyperplastic Stratified Squamous Epithelium with Mild Cellular Atypia.** Note the increase in small basal cells with dark nuclei that are not differentiating in a normal manner (arrows).



**Figure 4. Forestomach Epithelium Showing Marked Basal Cell Proliferation (B) Resulting from the Continuous Administration of a Carcinogen. The basal cells not only are proliferating but are failing to differentiate into squamous cells.**

Dysplasia is defined in most medical dictionaries or medical texts as abnormal development or malformation resulting from an abnormal embryologic anlage. It generally is applied to an organ as a whole. The use of the term dysplasia with the connotation of "preneoplastic" was first introduced in exfoliative cytology and histopathology to replace the term "atypical hyperplasia" for lesions of the uterine cervix in women [16,17]. Although some have argued against its use because of the ambiguity in its definition, it has come into wider histological usage for proliferative changes characterized by cellular atypia, alteration in the maturation sequence, or abnormal differentiation of cells within a tissue [18]. Dysplasia frequently is an indication of the emergence of a population of cells with more ominous biological behavior and may precede to development of overt malignancy. Extreme forms of dysplasia are sometimes called "carcinoma *in situ*." This type of change can be present for months or even years in the case of some human conditions before progression to malignancy occurs [18]. The terms dysplasia and carcinoma *in situ* are not commonly used in rodent carcinogenicity studies.

Hyperplasia and dysplasia may regress with permanent disappearance or later reoccurrence, persist without qualitative change in structure or behavior, undergo progressive growth without qualitative change in structure or behavior, or progress to another lesion of greater neoplastic potential (e.g., develop characteristics that increase the likelihood of malignancy). Of these four possibilities, progression to malignant neoplasia is the least likely to occur. In most experimental

models of initiation and promotion including skin [6] and liver [14], large numbers of hyperplastic lesions are observed from which only a relatively small number of carcinomas develop.

The benign neoplasms include a spectrum of lesions with varying neoplastic potential which, in most rodent organs or tissues, seem to be derived from foci of hyperplasia. Squamous cell papillomas of the skin or forestomach, for example, do not develop *de novo*, but develop from areas of epithelial hyperplasia. A papilloma is distinguished from hyperplasia based on the extent to which the epithelial proliferation causes the formation of papillae (e.g., finger-like stalks of stratified squamous epithelium overlying a thin connective tissue stroma) and the complexity of the papillary formation (Figures 5,6). Although a papilloma is often considered a benign neoplasm, only a relatively small number are autonomous and continue to grow and even fewer demonstrate progression to squamous cell carcinoma [19,20]. In experimental studies repeated applications of "initiators" increase the rate of conversion or progression to squamous cell carcinoma whereas "promoters" do not [21]. The progression of a papilloma to squamous cell carcinoma usually appears as an abrupt change involving a very limited part of the papilloma, supporting the theory that progression is the result of selection of a subpopulation of cells with selective growth advantage (Figures 7,8).



**Figure 5. Papillary Hyperplasia of the Forestomach Epithelium Adjacent to the Glandular Stomach (G). Compare with papilloma in Figure 6.**



**Figure 6. Squamous Cell Papilloma of the Forestomach of a Rat with Complex Papillae and Thin Stalk.**



**Figure 7. Squamous Cell Carcinoma Arising in a Papilloma. Cords of malignant squamous epithelium are invading the stalk (arrow).**



**Figure 8. High Magnification of Figure 7 Showing Invasion (arrows).**

Although a squamous papilloma of the skin or forestomach can be considered to have a greater neoplastic potential than simple epithelial hyperplasia, the papilloma is not an essential intermediate stage in the development of squamous cell carcinoma. Squamous cell carcinoma can arise directly from small foci of hyperplasia or dysplasia (Figures 9,10). In experimental studies with the skin or forestomach, this is most frequently observed with the repeated application of a complete carcinogen in contrast to the single application of a carcinogen followed by repeated applications of a promoter [21].

With many other organ systems, the transition from a benign to a malignant neoplasm does not appear to be as abrupt as that for stratified squamous epithelium. Neoplasms with a well demarcated border (e.g., not exhibiting invasion), relatively uniform growth pattern, and uniform well-differentiated cell type are generally considered benign (Figures 11,12). Variation in growth pattern, cellular pleomorphism (e.g., variation in phenotypic characteristics), and anaplasia (loss of differentiation) are believed to be the result of genetic instability and to indicate the potential for more ominous biological behavior (Figures 13 to 17). As such, these histological characteristics are used to make a diagnosis of malignancy. These changes can occur focally within a neoplasm that is otherwise benign in appearance and vary in degree and extent. Thus, evidence of actual invasion or metastases is not considered necessary to make a diagnosis of malignancy.



**Figure 9. Squamous Cell Carcinoma Arising in an Area of Basal Cell Hyperplasia. Note the prominent layer of basal cells with hyperchromatic nuclei and scant cytoplasm that have failed to differentiate into squamous cells (B) and clusters of malignant squamous cells invading the submucosa (arrow).**



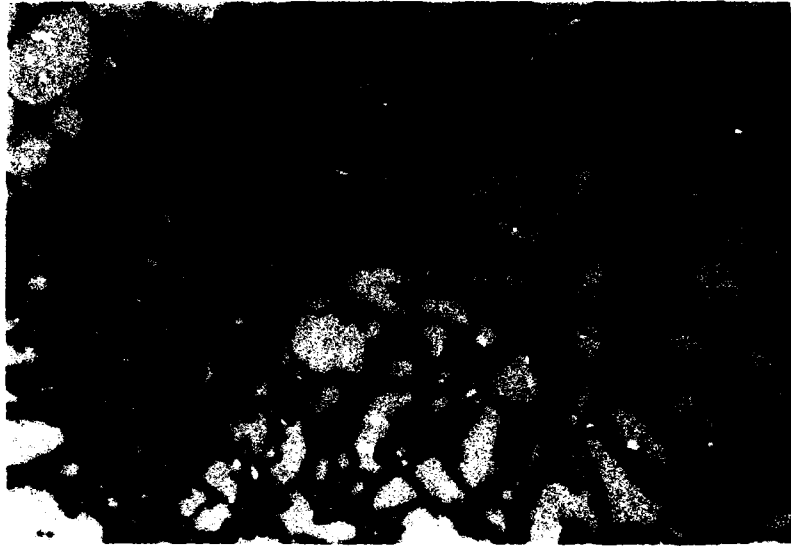
**Figure 10. Advanced Squamous Cell Carcinoma of the Forestomach that Has Invaded the Full Thickness of the Stomach Wall. Glandular stomach (G).**



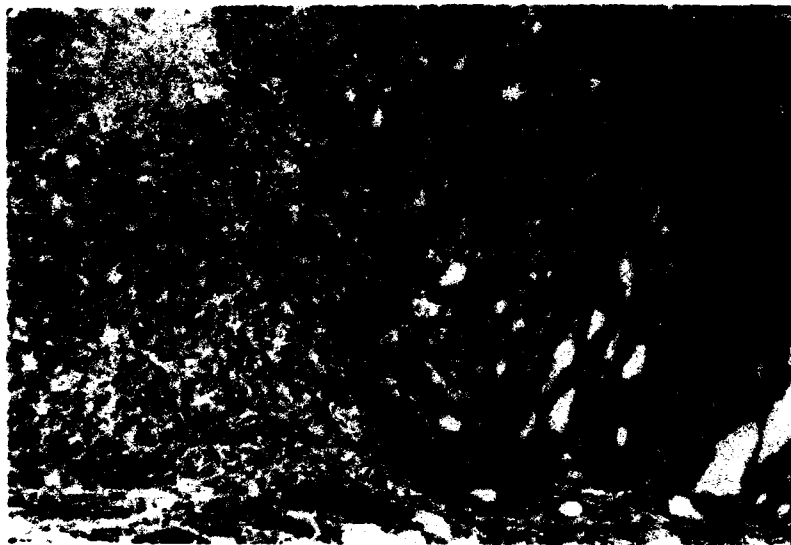
**Figure 11.** Follicular Cell Adenoma in the Thyroid of a Rat (arrows). The margins of this benign tumor are well defined.



**Figure 12.** High Magnification of the Follicular Cell Adenoma Shown in Figure 11. The neoplastic epithelium is a single layer of uniform cells with small hyperchromatic nuclei and scant cytoplasm.

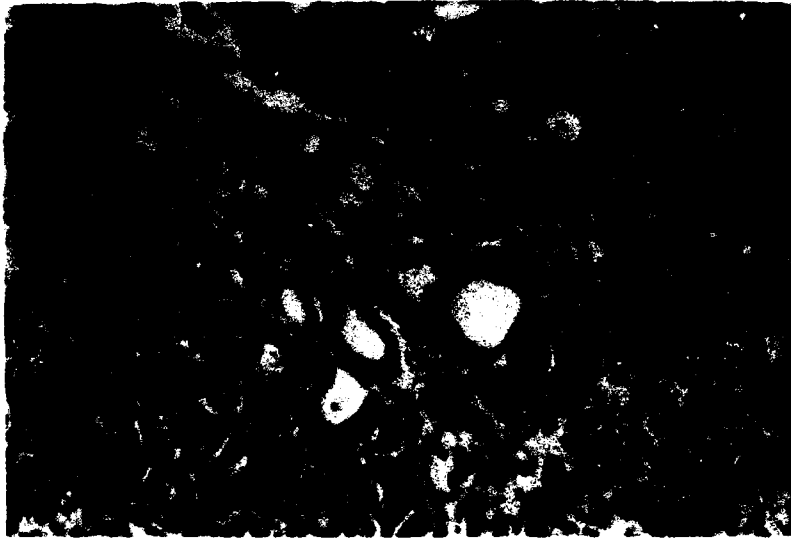


**Figure 13. Follicular Cell Adenoma Showing Heterogeneity of Growth Pattern and Slight Cellular Pleomorphism. The neoplastic cells may be arranged in small or large follicular or papillary patterns. These features suggest progression to malignancy.**

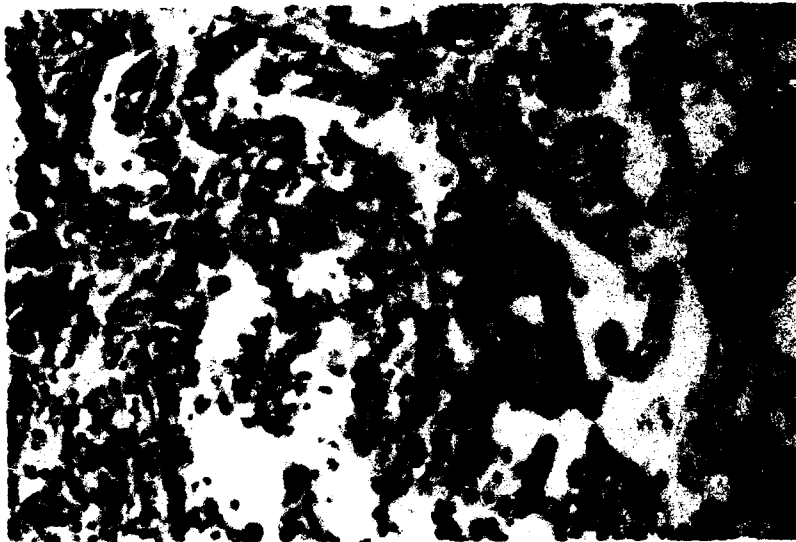


**Figure 14. Follicular Cell Carcinoma. Note the small follicular structures with lumens and the more solid areas of epithelial growth.**

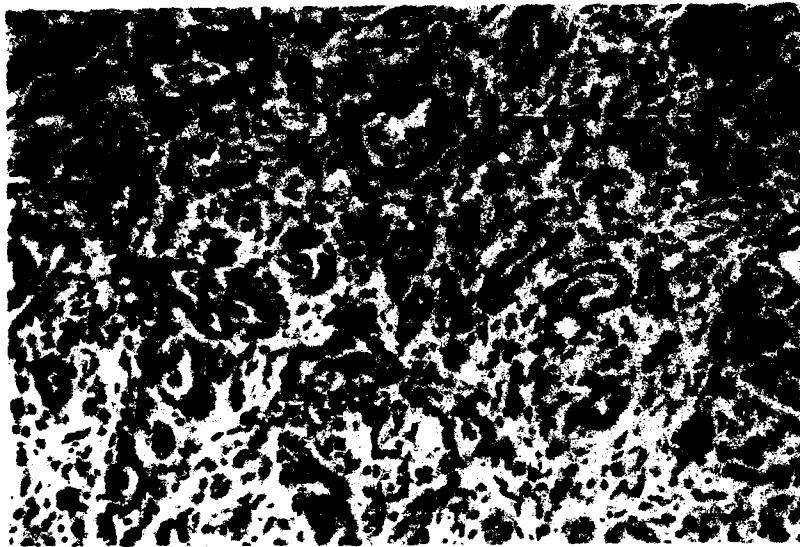




**Figure 15.** High Magnification of Follicular Cell Carcinoma Shown in Figure 14. The neoplastic epithelium is moderately well differentiated. This neoplasm might be expected to show minimal local invasion but is likely not to metastasize.



**Figure 16.** High Magnification of Poorly Differentiated Follicular Cell Carcinoma. Compare with Figure 15 and Figure 17. This neoplasm is locally invasive and more likely to metastasize.



**Figure 17. High Magnification of Anaplastic Follicular Cell Carcinoma.** Note the schirrous response characterized by production of collagen and inflammatory cells between the neoplastic epithelium. This neoplasm would have the poorest prognosis of the three follicular cell carcinomas shown in Figures 15 through 17.

In the preceding paragraphs, I have attempted to present a morphological perspective on neoplastic progression and the manner in which the various stages of cancer development are categorized by the pathologist. The concept of neoplastic progression and the limitations of morphological techniques to define the various stages in this progression are important considerations in the interpretation of studies of the biology of neoplasia as well as bioassays for chemical carcinogenicity.

#### REFERENCES

- 1 Rather, L.J. (1978) *The Genesis of Cancer: A Study in the History of Ideas.* Johns Hopkins University Press, Baltimore, MD.
- 2 Willis, R.A. (1952) *The Spread of Tumors in the Human Body.* Butterworth and Co., London.
- 3 Robbins, S.L. (1974) *Pathologic Basis of Disease.* W.B. Saunders Co., Philadelphia, PA, pp. 1401-1406.
- 4 Foulds, L. (1969) *Neoplastic Development, Vol. 1.* Academic Press, New York.
- 5 Foulds, L. (1975) *Neoplastic Development, Vol. 2.* Academic Press, New York.
- 6 Farber, E. and Cameron, R. (1981) The sequential analysis of cancer development. *Adv. Cancer Res.* 31, 125-226.
- 7 Nowell, P.C. (1976) The clonal evolution of tumor cell populations. *Science* 194, 23-28.

- 8 Folkman, J. and Klagsbrun, M. (1975) Tumor angiogenesis: Effect on tumor growth and immunity. In: A. Gottlieb (Ed.), Symposium on Fundamental Aspects of Neoplasia. Springer-Verlag, New York, 331-340.
- 9 Liotta, L.A., Tryggvason, K., Garbisa, S.K. Foltz, C. and Shafie, S. (1980) Metastatic propensity correlates with tumor cell degradation of basement membrane collagen. *Nature* 284, 67-68.
- 10 Barsky, S.H., Siegal, G.P., Jannotta, F. and Liotta, L.A. (1983) Loss of basement membrane components by invasive tumors but not by their benign counterparts. *Lab. Invest.* 49, 140-147.
- 11 Nowell, P.C. (1983) Tumor progression and clonal evolution: the role of genetic instability.. In: J. German (Ed.), Chromosome Mutation and Neoplasia. Alan R. Liss, Inc., New York, pp. 413-432.
- 12 Nicolson, G.L. (1984) Tumor progression, oncogenes and the evolution of metastatic phenotypic diversity. *Clin. Exp. Metastasis* 2, 85-105.
- 13 Henson, D.E. (1982) Heterogeneity in tumors. *Arch. Pathol.* 106, 597-598.
- 14 Pitot, H.C. (1986) The natural history of neoplastic development: Progression. In: H.C. Pitot (Ed.), Fundamentals of Oncology, Marcel Dekker, New York, pp. 163-200.
- 15 Dorland's Illustrated Medical Dictionary, 24th edition. W.B. Saunders Co., Philadelphia, PA.
- 16 Papanicolaou, G.N. (1949) Survey actualities and potentialities of exfoliative cytology in cancer diagnosis. *Ann. Intern. Med.* 31, 661.
- 17 Reagan, J.W., Seidemand, I.L. and Saracusa, Y. (1983) The cellular morphology of carcinoma *in situ* and dysplasia or atypical hyperplasia of the uterine cervix. *Cancer* 6, 224.
- 18 Rywlin, A.M. (1984) Terminology of premalignant lesions in light of the multistep theory of carcinogenesis. *Human Pathol.* 15, 806-807.
- 19 Burns, F.J., Vanderlaan, M., Snyder, E. and Albert, R.E. (1976) Induction and progression kinetics of mouse skin papillomas. In: T.J. Slaga, A. Sivak, and R.K. Boutwell (Eds.) Carcinogenesis, Vol. 2, Modifiers of Chemical Carcinogenesis. Raven Press, New York.
- 20 Colburn, N.H. (1980) Tumor promotion and preneoplastic progression. In: T.J. Slaga (Ed.) Carcinogenesis, Vol. 5, Modifiers of Chemical Carcinogenesis. Raven Press, New York.
- 21 Hennings, H., Shores, R., Wenk, M.L., Spangler, E.F., Tarone, R. and Ysupa, S.H. (1983) Malignant conversion of mouse skin tumors is increased by tumor initiators and unaffected by tumor promoters. *Nature* 304, 67-69.

## STEM CELL THEORY OF CARCINOGENESIS

James E. Trosko and Chia-Cheng Chang

*Department of Pediatrics/Human Development, Michigan State University, East Lansing, MI 48824*

### SUMMARY

Our present understanding of the carcinogenic process, involving complex interactions of genetic, developmental, sex, dietary, and environmental factors during the multistage initiation/promotion/progression process of carcinogenesis, would lead us to reject simplistic nonbiologically based risk assessment models. This understanding, plus recent results of the National Toxicology Bioassay program and of the studies of short-term tests for genotoxicity, has challenged the primary paradigm of "carcinogens as mutagens" which governs our current risk assessment models.

The concepts of the stem cell theory of cancer, of oncogenes/tumor suppressor genes, of gap junctional intercellular communication, and of mutagenic and epigenetic mechanisms must be integrated into a biologically based model of the multistage nature of carcinogenesis. Current understanding of the complex interactions during this process prevents us from believing a simple and accurate biologically based risk assessment model will be developed soon, if ever.

### INTRODUCTION

#### *The Need for a Biologically Based Risk Assessment Model*

Until most recently, models designed to assess risk of getting cancer after exposure to radiation and chemicals have not been based on any mechanistic understanding of carcinogenesis. One cannot fault the creators of these models because our understanding of carcinogenesis has been, and still is, to a significant extent, very limited. Within the last couple of decades, several paradigms have greatly influenced, not only our way of viewing the carcinogenesis progress, but also our view of the risk assessment models.

Since the coining of the term "genotoxicity" [1], about the time it was demonstrated that a chemical carcinogen, *N*-acetoxy-2-acetyl aminofluorene, could induce DNA lesions which were repaired in a manner similar to ultraviolet-light-induced DNA lesions [2], the stage was set to explore the hypothesis that chemical "carcinogens" (see [3] for the use of quotation marks) elicited part or all of their toxic effects via DNA damage and mutation. With the development of a bacterial assay to screen for potential carcinogens [4], the paradigm of "carcinogens as mutagens" was born. This provided the field of cancer research with a specific and practical means to study chemical

carcinogens [5]. Clearly, while new knowledge gained by research guided by this paradigm has been valuable, it has tended to blind our view of other potential mechanisms of carcinogenesis.

The inadequacy of the paradigm of chemically induced genotoxicity to explain the multiple acute and chronic effects of chemical exposure is highlighted in the field of cancer risk assessment. It now is very clear that current paradigms, strategies, and models, underlying both the *in vitro* screening tests and the *in vivo* bioassays, are bankrupt [6].

Three recent reports have highlighted major problems in the characterization of the carcinogenic potential of chemicals using standard animal bioassays and short-term assays for genotoxicity [7-9]. Moreover, one of the most striking facts was illustrated by Tennant et al. when they stated "... the three most potent carcinogens (TCDD, polybrominated biphenyls, and reserpine) produced no genetic toxicity in any of the four short-term tests studied. One may speculate that these three carcinogens do not operate primarily by direct interaction with DNA, as suggested by the tumor promoting capability of the three carcinogens in model systems for two-stage liver carcinogenesis" [10].

Consequently, a major challenge to develop a biologically based cancer risk assessment model in human beings must depend on (1) new understanding of the molecular, biochemical, cellular, and physiological mechanisms of the carcinogenic process; (2) new risk assessment models integrating all the important *biological* facts related to carcinogenesis; (3) an understanding of nongenotoxic, as well as the genotoxic, mechanisms leading to either cytotoxic or noncytotoxic influences on carcinogenesis and the development of assays to detect these "epigenetic" mechanisms of toxicities; and (4) basic mechanistic understanding of chemical interactions to reflect "real-life" situations (i.e., genetic/sex/developmental stage differences; mixtures of chemicals; low dose, chronic exposures) [11].

#### **Multistage Nature of Carcinogenesis: Implications for Cancer Risk Assessment**

All theories must be based on experimentally solid observations. Theories of carcinogenesis, derived from experimental carcinogenesis studies in animals, epidemiological data on human cancers, and a wide variety of *in vitro*, biochemical, and molecular studies have suggested that the formation of a malignant tumor is not a "one-hit" event. Instead, all of the evidence supports, overwhelmingly, that there is an evolution of phenotypic (and hence, presumably, genotoxic) changes from the normal cell to the invasive, metastasizing cell [12].

This multistep process seems to involve the loss of the ability to terminally differentiate [13-15], to control growth or contact inhibit [16-18], to have dysfunctional gap junctional intercellular communication [19], and to be able to migrate to distal tissues and to invade these tissues [20]. The tumor, once formed, appears to be clonally derived from a single errant stem cell [21,22], even

though most tumors consist of a heterogeneous mixture of phenotypically and genotypically marked cells [20]. The heterogeneity appears to be the result of some instability of either the genotype or phenotype control during the clonal expansion of the single tumor progenitor cell.

A variety of concepts have been generated to explain one or more of these observations related to the multistep carcinogenic process. The objective of this brief survey will be to try an integration of these concepts into one that reflects cancer as a tissue with a problem of homeostatic dysfunction. The major concepts to be integrated are (1) the initiation/promotion/progression model of the multistep nature of carcinogenesis [23-25]; (2) the oncogene concept [26]; (3) "cancer as a disease of differentiation" [13,15] or as "oncogeny as partially blocked or blocked ontogeny" [14]; (4) cancer as a stem cell disease [21,22]; and (5) the concept of intercellular communication [27].

In experimental animal studies (i.e., mouse skin, rat liver) [23,24], discrete and distinctive phases, identified as initiation, promotion, or progression, were identified during the carcinogenic process. While it is clear we still do not understand the underlying molecular mechanisms of each of these operational phases, it also is clear that they are distinctly different. The process of initiation seems to involve an irreversible genetic event in a single cell that has the capacity to proliferate (i.e., a stem or progenitor cell). Promotion, on the other hand, is a process that is dependent on chronic administration of a stimulus, which among other things, brings about the clonal expansion of the initiated cell [28]. The process of promotion appears to be potentially reversible and interruptible. Progression has been conceptualized as that process that converts a promoter-dependent, pre-malignant cell to a tumor-promoter independent cell [11]. True mutagens appear to be good initiators, which suggests the initiation process involves an irreversible mutagenic event. Tumor promoting conditions, be they caused by chemicals, cell removal, cell death, or oncogenic gene products affecting cell proliferation [29], seem to be good mitogens, rather than mutagens. Agents having the ability to convert premalignant cells to malignant cells also appear to be mutagenic [30]. The concept of "I-P-I" (initiation/promotion/initiation) [31] was developed to support the two-hit (multi-hit) model of carcinogenesis [32]. Recent evidence derived from the retinoblastoma [33,34] and Wilms tumor models [35], as well as experimental skin and liver cancers, [36-38] suggest at least two mutational events are needed to trigger the cancer phenotype.

In some of these studies, the second mutation seems to involve a deletion of a normal "tumor suppressor" or anti-oncogene [39]. It would, at this time, be premature to conclude that all second event mutations involve deletion mutations.

### ***Cancer as a Stem Cell Disease***

The concept of cancer as a stem cell disease or a disease of differentiation was derived from a variety of different observations: (1) the similarity of stem cells and tumor cells, such as tissue origin,

extensive proliferative potential, and tissue-specific differentiation potential; (2) the implication of small target size for tumor control with radiotherapy; (3) the demonstration that clonogenic potential, self-renewal capacity, and cell differentiation features are restricted to subpopulations of cells in tumors; and (4) the ability to induce terminal differentiation of some neoplastic cells *in vitro* by various natural differentiation factors or exogenous chemical compounds [40].

Possibly one of the most significant observations supporting the stem cell theory of carcinogenesis was made by Nakano and Ts'o [41]. They demonstrated that a small subpopulation of less differentiated and contact insensitive cells was more susceptible to neoplastic transformation than populations of cells depleted of these "presumptive" stem-like cells. This, of course, has major implications for risk assessment because if not all cells are equal targets for carcinogenesis, and if the stem cell population is modulated by genetic, developmental, or environmental factors, then the risk associated with exposure to a carcinogenesis would be a function of that population size.

The recent demonstration of cells from normal human epithelial tissues, which exhibit similar phenotypic characteristics (i.e., contact insensitivity, ability to differentiate) [40], suggests that carcinogenesis in humans might also depend on the same kind of stem cell. The basis for interspecies differences in response to carcinogens might, in part, be the result of differences in these subpopulations of stem-like cells.

To begin, one must define what a stem cell is. Because stem cells have not been extensively characterized, only two major phenotypic characteristics seem to be applicable to all stem cells: (1) their ability for self-renewal, and (2) their ability to terminally differentiate into the specific cells of the tissue of origin.

To integrate the concept of initiation/promotion/progression with the cancer as a stem cell disease concept, it has been postulated that the process of initiation prevents a stem cell from terminally differentiating [14, 28]. Evidence has been generated from mouse skin cells, exposed to initiators, that noninitiated keratinocytes can differentiate under certain conditions *in vitro*, whereas initiation induces differentiation-resistant cells [42]. However, these differentiation-resistant cells have self-renewal capabilities.

In the rat liver systems, after initiation of the rat, followed by promoting conditions, foci, which have altered biochemical characteristics compared with the surrounding normal hepatocytes, are obviously clonally derived stem-like cells that cannot terminally differentiate, yet can self-renew. Therefore, the premalignant lesions, such as the papilloma of the skin, the enzyme-altered foci of the liver, or the polyps of the colon, might all be viewed as the clonal expanded population of initiated stem cells of those respective organs.

### ***Intercellular Communication: Regulation of Cell Growth and Differentiation***

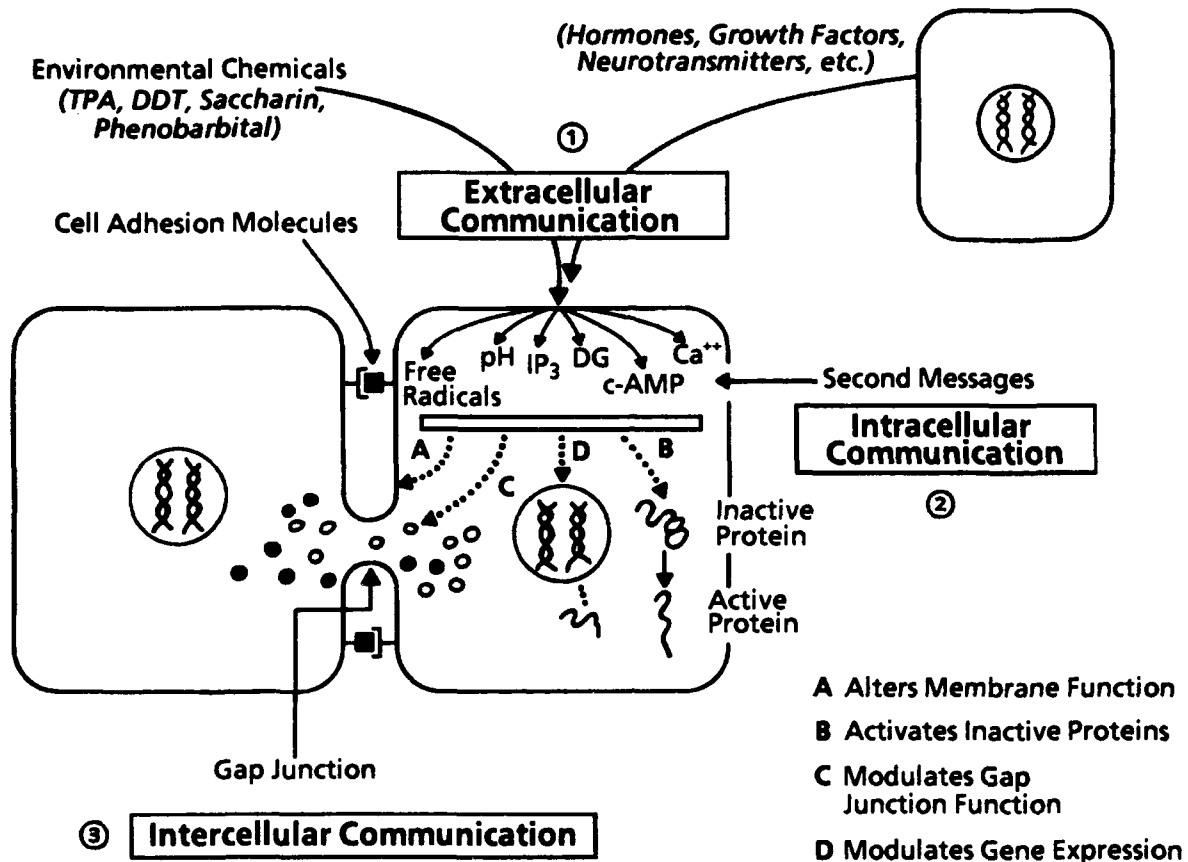
To help tie together the concept of cancer as a disease of differentiation or of growth control with both the previously discussed concepts of cancer and oncogene/anti-oncogene concepts, the concept of cell-to-cell communication will be discussed. In fact, it will be postulated that intercellular communication is the integrating factor to place the initiation/promotion/progression theory together with the idea that cancer is a disease of growth control and differentiation, involving oncogenes.

In multicellular organisms, the delicate orchestration of three major cellular functions is required: (1) cell proliferation control, (2) ordered differentiation of stem and progenitor cells, and (3) adaptive control of differentiated functions. To mediate the homeostatic control of these very different functions, during the evolution of the multicellular organism, three major forms of cell communication have emerged that allow different cells to respond differentially or collectively to changes in the external or internal environments. These three forms of cell communication mechanisms can be thought of as (1) *extracellular* (transfer of molecules, such as hormones, peptide growth regulators or neurotransmitters, from one cell type over space and distance to another cell type); (2) *intracellular* (transmembrane-triggered ionic/molecular or "second-message" type regulators within the cell); and (3) *intercellular* (transfer of ions and small molecular weight molecules through the membrane bound-protein structure, the gap junction) [43] (Figure 1).

It now seems clear that all three forms of cell communication are linked to each other because hormones, growth factors, and neurotransmitters, which are known to trigger various transmembrane or other intracellular homeostatic changes in cell physiology (i.e., activation of adenylate cyclase, protein kinases, gene expression changes, etc.), up or down regulate gap junctional intercellular communication in cells [44,45]. From emerging studies during development, the expression of the gap junction message, protein and function seems to correlate with the early need to balance rapid proliferation of cells, careful segmentation or sequestration of differentiation during organogenesis and development, and the control of differentiated functions in both excitable and nonexcitable tissues (i.e., heart cells or pancreatic cells) [46].

The fact that cells in culture have their growth controlled by cell contact ("contact inhibition") [47], as well as in the solid tissue *in vivo*, suggests gap junctional intercellular communication helps to maintain the level of critical ions and second messages below what would be a threshold level needed for cell proliferation.





**Figure 1. The Heuristic Schemata Characterizes the Postulated Link Between Extracellular Communication and Intercellular Communication via Various Intracellular Transmembrane Signaling Mechanisms.** It provides an integrating view of how the neuroendocrine immune system ("mind or brain/body connection") and other multisystem coordinations could occur. While not shown here, activation or altered expression of various oncogenes (and "anti-oncogenes") also could contribute to the regulation of gap junction function.

In addition, control of maturation of cells in tissues with "programmed" or constant turnover of differentiated cells seems to involve the delicate interaction of extracellular and intercellular communication. Germ cell maturation in both the ovary and testis seems to involve hormone regulation of gap junctions between the "nurse" cells and the developing germ cells [48-51].

There does seem to be a difference in the manner in which homeostatic control of growth and differentiation occurs in organ systems that are either "open-ended" or "closed" systems (i.e., skin versus liver). Organs such as the liver must have strict regulation of cell proliferation to maintain a steady-state size (Figure 2), whereas, in the skin, where there is a constant loss of differentiated keratinocytes, the need is for steady cell proliferation.

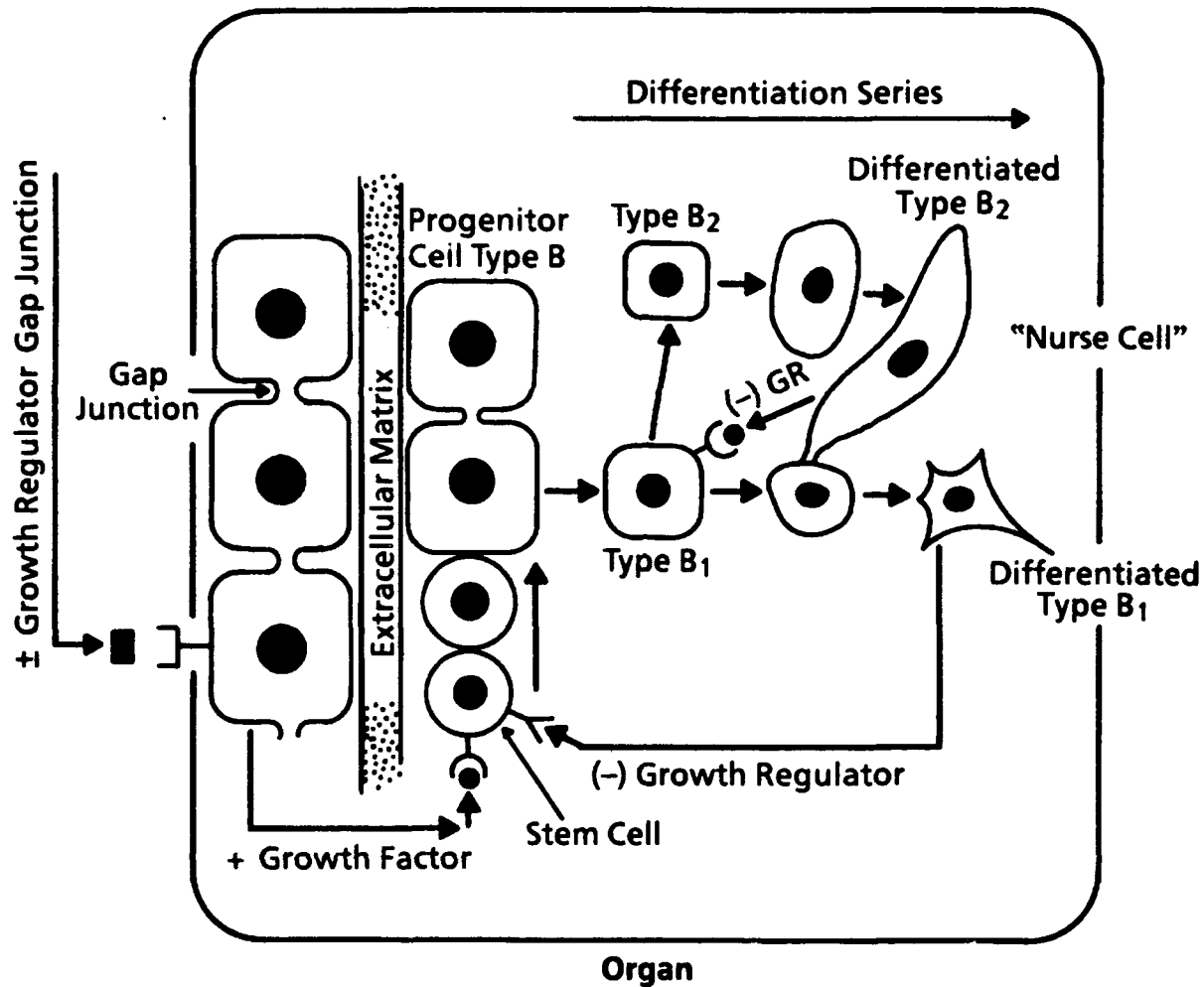


Figure 2. A Diagram to Illustrate the Interrelationship of Intercellular Communication by Positive and Negative Growth Regulators on Stem Cell Growth and Differentiation and Intercellular Communication via Gap Junctions in a Closed Organ System. [From Trosko and Chang, In Press, with permission from Lewis Press, Inc.]

The concept of "chalones" or negative, as well as positive, growth regulators preceded the rigorous demonstration of the existence of these kinds of molecules [52]. One speculative model to explain the control of growth and differentiation is that early stem cells do not have functional gap junctions but are controlled or suppressed by negative growth regulators produced by their terminally differentiated progeny. When either stimulated by positive growth factors or released from mitotic suppression by the reduction of negative growth regulators (i.e., because of a loss of terminally differentiated cells producing the negative growth regulators, or of the inability to respond to negative growth regulators), the stem cell will start to proliferate and differentiate. The differentiation of at least one of the stem cell daughter cells would then be accompanied by, and dependent on, the expression of gap junctions. These progenitor and differentiated cells would be

contact inhibited. They will only divide if these gap junctions are down-regulated by growth factors [53], hormones [54], or certain mitogenic chemicals [11]. Consequently, normal growth control of either stem or progenitor cells is the result of the interrelationship of the extracellular-intracellular-intercellular connection within and between tissues.

### ***Dysfunctional Intercellular Communication as the Basis for Carcinogenesis***

Starting with the observations that: (1) cancer cells seem to be unable to terminally differentiate or contact-inhibit [14,16,17]; (2) gap junctional communication is strongly correlated with the control of cell growth and differentiation [27]; and (3) most cancer cells seem to have dysfunctional intercellular communication for a variety of reasons ("exceptions" to this generalization might be explained by a number of reasonable technical means used to measure gap junction function [19] and to the phenomenon of "selective communication" [55]); and (4) assuming that the cancer cell is derived from a stem cell, we are led to believe one of the earliest steps of carcinogenesis (i.e., initiation) is the prevention of stem cell differentiation. This probably involves a mutational event in an oncogene that controls *terminal* differentiation but not self-renewal or proliferation.

The major implication of this hypothesis is that the normal stem cell is *immortal* and initiation is the event that prevents the *mortalization* of the stem cell by blocking or partially blocking its ability to terminally differentiate [56]. This runs counter to the accepted wisdom that the early step in carcinogenesis is the "immortalization" of a normal, but mortal, cell [57,58].

Although pure "initiated" cells have not been studied, one might infer from *in vivo* initiation/promotion studies [23] and *in vitro* transformation studies [59] that the initiated cell can be contact inhibited until and unless it is released by promoting conditions known to reduce gap junctions *in vivo* and *in vitro* [60-64]. Chemical tumor promoters and cell removal or cell killing can reduce gap junction communication by either blocking gap junction function, reducing gap junctions or affecting the expression of the gap junction message. It is not known yet whether chemicals, which modulate gap junctions, can differentially affect normal and initiated cells.

With the recent demonstration that various oncogenes, which code for transmembrane signaling elements, receptors or growth factors, can modulate regulated gap junctions (i.e., *src*, *ras*, *mos*, polyomavirus middle T antigen, *neu*, but not *myc*), an idea has been generated that a stably over-expressed normal or mutated oncogene would replace the need for chronic exposure of the initiated cell to either exogenous or endogenous inhibitors of intercellular communication [see 43,44,56]. In other words, initiation might involve the mutation of an oncogene needed for *terminal* differentiation. Promotion would occur when endogenous or exogenous factors release the contact-inhibited cell to proliferate and clonally expand and selectively accumulate. During the clonal

expansion, if another genetic "hit" occurs because of the mitotic activity, in a gene controlling the gap junction structure or its regulation, a stable down regulation of intercellular communication would occur. At this point, no external chemical promoter is needed and the cell would be unable to terminally differentiate or contact inhibit [65].

The demonstration that tumor metastasis and reduced gap junctional communication seem to be correlated [66-68] tends to be consistent with this hypothesis. While it can be argued that the loss of gap junctional communication is a consequence of carcinogenic transformation and not the "cause," the demonstration that when gap junctional communication is down regulated by phorbol esters, the cell changes shape, DNA synthesis occurs, and the cell divides. In addition, the use of temperature-sensitive src gene mutants suggests that the down-regulation of gap junctions precedes transformation [69].

Finally these observations suggest that the initiation step blocks the terminal differential possibly by a mutational event, while the promotion phase involves the inhibition of intercellular communication, which is not a mutagenic event. A mutation event, which could down regulate gap junctions, might be responsible for the progression step after there has been clonal expansion of the initiated cell.

#### ***Implications for a Biologically Based Risk Assessment Model***

It goes without saying that carcinogenesis is a complex multistep process. Extrapolating any knowledge, based solely on experimental initiation/promotion studies on animals, would be ignoring the fact that humans are constantly exposed, simultaneously to initiators/anti-initiators and promoters/antipromoters throughout their lives. However, there are some important lessons of which we ought to be aware.

The first seems to be that the promotion phase of carcinogenesis is different from the initiation phase. Promotion appears to be a very critical process [70], which can be mediated by endogenous factors that individuals might not be able to escape at certain times of development (i.e., hormones, growth factors, neurotransmitters, or neuropeptides) or by exogenous factors (chemicals, viral oncogenes). Chemical promoters also seem to have real thresholds [71] and need to be present for regular and chronic periods of time. Real-life exposures to many chemicals, as well as interactions with endogenous factors, can modulate the effect of potential inhibitors of intercellular communication. Additivity, synergisms, and antagonisms of inhibitors of intercellular communication have been demonstrated [72,73].

The "good news/bad news" phenomenon of chemical exposure also has been noted for chemicals known to inhibit intercellular communication and to promote tumors; namely, their ability also to inhibit carcinogenesis or specifically, initiation [74].

The role of stem cells in carcinogenesis also implies that not all cells of the body are "targets" for carcinogenesis. If the stem cell pool varies during development and aging, as one would predict, then the risk to carcinogenesis might also depend on knowing this important parameter. In addition, if there does exist for certain chemicals a specific effect on stem or initiated cells, as distinct from the progenitor or differentiated cell, knowledge of this fact will have to be introduced into an accurate biologically based risk assessment model.

#### ACKNOWLEDGMENTS

The authors wish to acknowledge the research support provided by grants to James Trosko from the National Cancer Institute [CA21104], the U.S. Air Force Office for Scientific Research [AFOSR-86-0084], and a gift from R.J. Reynolds, Inc. We also want to thank Dr. B.V. Madhukar, Dr. Saw Yin Oh, Mrs. Beth Lockwood, Ms. Heather Rupp, Mr. William Paradee, and Mr. Edwin de Feyter for their research and technical support. In addition, we sincerely appreciated the cheerful and competent secretarial skills of Mrs. Darla Conley in the preparation of this manuscript.

#### REFERENCES

- 1 Ehrenberg, L., Brookes, P., Druckrey, H., Lagerlof, B., Litwin, J. and Williams, G. (1973) The relation of cancer induction and genetic damage. *Ambio Special Report* 3, 15-16.
- 2 Lieberman, N.W., Baney, R.N., Lee, R.E., Sell, S. and Farber, E. (1971) Studies on DNA repair in human lymphocytes treated with ultimate carcinogens and alkylating agents. *Cancer Res.* 3, 1292-1306.
- 3 Trosko, J.E., Jone, C. and Chang, C.C. (1983) The role of tumor promoters on phenotypic alterations affecting intercellular communication and tumorigenesis. *Ann. NY Acad. Sci.* 407, 316-327.
- 4 Ames, B.N. Durston, W.E., Yamasaki, E. and Lee, F.D. (1973) Carcinogens are mutagens: A simple test system combining liver homogenates for activation and bacteria for detection. *Proc. Natl. Acad. Sci. USA* 70, 2281-2285.
- 5 Miller, J.A. and Miller, E.C. (1977) Ultimate chemical carcinogens as reactive mutagenic electrophiles. In: H.H. Hiatt, J.D. Watson, and J.A. Winsten (Eds.), *Origins of Human Cancer*, Cold Spring Harbor Laboratory, Cold Spring Harbor, New York, pp. 605-627.
- 6 Trosko, J.E. (1988) A failed paradigm: Carcinogenesis is more than mutagenesis. *Mutagenesis* 3, 363-364.
- 7 Clayson, D.B. (1987) The need for biological risk assessment in reaching decisions about carcinogens. *Mutat. Res.* 185, 243-269.

- 8 Clive, D. (1987) Genetic toxicology: From theory to practice. *J. Clin. Res. Drug. Dev.* 1, 11-41.
- 9 Ames, B.N., Magaw, R. and Gold, L.S. (1987) Ranking possible carcinogenic hazards. *Science* 236, 271-280.
- 10 Tennant, R.W., Margolin, B.H., Shelby, M.D., Zeiger, E., Haseman, J.K., Spalding, J., Caspary, W., Resnick, M., Stasiewicz, S., Anderson, B. and Minor, R. (1987) Prediction of chemical carcinogenicity in rodents from *in vitro* genetic toxicity assays. *Science* 236, 933-941.
- 11 Trosko, J.E. and Chang, C.C. (1988) Nongenotoxic mechanisms in carcinogenesis: Role of inhibited intercellular communication. In: R.W. Hart and F.D. Hoerger (Eds.), *Banbury Report 31: Carcinogen Risk Assessment: New Directions in the Qualitative and Quantitative Aspects*, Cold Spring Harbor Laboratory, Cold Spring Harbor, New York, pp. 139-170.
- 12 Nicolson, G.L. (1987) Tumor cell instability, diversification, and progression to the metastatic phenotype: From oncogene to oncofetal expression. *Cancer Res.* 47, 1473-1487.
- 13 Markert, C. (1988) Neoplasia: A disease of cell differentiation. *Cancer Res.* 28, 1908-1914.
- 14 Potter, V.R. (1978) Phenotypic diversity in experimental hepatomas: The concept of partially blocked ontogeny. *Br. J. Cancer* 38, 1-23.
- 15 Pierce, G.B. (1980) Neoplasms, differentiation, and mutations. *Am. J. Pathol.* 77, 103-118.
- 16 Borek, C. and Sachs, L. (1966) The difference in contact inhibition of cell replication between normal cells and cells transformed by different carcinogens. *Proc. Natl. Acad. Sci. USA* 56, 1705-1711.
- 17 Corsaro, C.M. and Migeon, B.R. (1977) Comparison of contact-mediated communication in normal and transformed human cells in culture. *Proc. Natl. Acad. Sci. USA* 74, 4476-4480.
- 18 Abercrombie, M. (1979) Contact inhibition and malignancy. *Nature* 281, 259-262.
- 19 Kanno, Y. (1985) Modulation of cell communication and carcinogenesis. *Japan. J. Physiol.* 35, 693-707.
- 20 Nicolson, G.L. (1984) Generation of phenotypic diversity and progression in metastatic tumors. *Cancer Metastasis Rev.* 3, 25-42.
- 21 Fialkow, P.J. (1979) Clonal origin of human tumors. *Ann. Rev. Med.* 30, 135-176.
- 22 Nowell, P.C. (1976) The clonal evolution of tumor cell populations. *Science* 194, 23-28.
- 23 Boutwell, R.K. (1974) The function and mechanisms of promoters of carcinogenesis. *CRC Crit. Rev. Toxicol.* 2, 419-443.
- 24 Pitot, H.C., Goldsworthy, T. and Moran, S. (1981) The natural history of carcinogenesis: Implications of experimental carcinogenesis in the genesis of human cancer. *J. Supramol. Struct. Cell. Biochem.* 17, 133-146.
- 25 Weinstein, I.B., Gattoni-Celli, S., Kirschmeier, P., Lambert, M., Hsiao, W., Backer, J. and Jeffrey, A. (1984) Multistage carcinogenesis involves multiple genes and multiple mechanisms. *J. Cell. Physiol.* 3, 127-137.

- 26 Bishop, J.M. (1983) Cellular oncogenes and retroviruses. *Ann. Rev. Biochem.* 52, 301-354.
- 27 Loewenstein, W.R. (1979) Junctional intercellular communication and the control of growth. *Biochem. Biophys. Acta* 560, 1-65.
- 28 Trosko, J.E. and Chang, C.C. (1980) An integrative hypothesis linking cancer, diabetes, and atherosclerosis: The role of mutations and epigenetic changes. *Med. Hypoth.* 6, 455-468.
- 29 Trosko, J.E., Chang, C.C. and Madhukar, B.V. (1987) Chemical and oncogene modulation of intercellular communication in tumor promotion. In: H.A. Milman and E. Elmore (Eds.), *Biochemical Mechanisms and Regulation of Intercellular Communication*. Princeton Scientific Publ., Princeton, New Jersey, pp. 209-236.
- 30 Hennings, H., Shores, R., Wenk, M.L., Spangler, E.F., Tarone, R. and Yuspa, S.H. (1983) Malignant conversion of mouse skin tumors is increased by tumor initiators and unaffected by tumor promoters. *Nature* 304, 67-69.
- 31 Potter, V.R. (1981) A new protocol and its rationale for the study of initiation and promotion of carcinogenesis in rat liver. *Carcinogenesis* 2, 3175-3179.
- 32 Moolgavkar, S.H. (1986) Carcinogenesis modeling: From molecular biology to epidemiology. *Ann. Rev. Public Health* 7, 151-169.
- 33 Moolgavkar, S.H. and Knudson, A.G. (1981) Mutation and cancer: A model for human carcinogenesis. *J. Natl. Cancer Inst.* 66, 1037-1052.
- 34 Murphree, A.L. and Benedict, N.F. (1984) Retinoblastoma: Clues to human oncogenesis. *Science* 232, 1028-1033.
- 35 Koufos, A., Hansen, M.F., Copeland, N.G., Jenkins, N.A., Lampkin, B.C. and Cavenee, W.L. (1985) Loss of heterozygosity in three embryonal tumors suggests a common pathogenetic mechanism. *Nature* 316, 330-334.
- 36 Fry, R.J.M., Rey, R.D., Grube, D. and Staffeldt, E. (1982) Studies on the multistage nature of radiation carcinogenesis. In: H. Hecker, N.E. Fusenig, W. Kunz, F. Marks, and H.N. Thielmann (Eds.), *Carcinogenesis*, Vol. 7, Raven Press, New York, pp. 155-165.
- 37 Scherer, E., Feringa, A.W. and Emmelot, P. (1984) Initiation-promotion-initiation: Induction of neoplastic foci within islands of precancerous liver cells in the rat. In: M. Borzanyi, N.E. Day, K. Lapis, and H. Yamasaki (Eds.), *Models, Mechanisms and Etiology of Tumor Promotion*, IARC Sci. Publ., Lyon, France, pp. 57-66.
- 38 Reddy, A.L. and Fialkow, P.J. (1983) Papillomas induced by initiation-promotion differ from those induced by carcinogen alone. *Nature* 304, 69-71.
- 39 Knudson, A.G. (1985) Hereditary, cancer, oncogenes, and anti-oncogenes. *Cancer Res.* 45, 1437-1443.
- 40 Chang, C.C., Trosko, J.E., El-Fouly, M.H., Gibson-D'Ambrosio, R.E. and D'Ambrosio, S.M. (1987) Contact insensitivity of a subpopulation of normal human fetal kidney epithelial cells and of human carcinoma cell lines. *Cancer Res.* 47, 1634-1645.

- 41 Nakano, S. and Ts'c, P.O.P. (1981) Cellular differentiation and neoplasia: Characterization of subpopulation of cells with neoplasia-related growth properties of Syrian hamster embryo cell culture. *Proc. Natl. Acad. Sci. USA* 78, 4995-4999.
- 42 Yuspa, S.H. and Morgan, D.L. (1981) Mouse skin cells resistant to terminal differentiation associated with initiation of carcinogenesis. *Nature* 293, 72-74.
- 43 Trosko, J.E., Chang, C.C., Madhukar, B.V. and Oh, S.Y. (In Press) Chemical, oncogene, and growth regulation modulation of extracellular, intracellular, and intercellular communication. In: W.C. DeMello (Ed.), *Cell-Cell Communication*, CRC Press, Boca Raton, FL.
- 44 Trosko, J.E. and Chang, C.C. (1988) Chemical and oncogene modulation of gap junctional intercellular communication. In: R. Lagenbach, E. Elmore, and J.C. Barret (Eds.), *Tumor Promoters: Biological Approaches for Mechanistic Studies and Assay Systems*, Raven Press, New York, pp. 97-111.
- 45 Spray, D.C. and Bennett, M.V.L. (1985) Physiology and pharmacology of gap junctions. *Ann. Rev. Physiol.* 47, 281-303.
- 46 Hertzberg, E.L. and Johnson, R.G. (Eds.), (1988) *Gap Junctions*, Alan R. Liss, Inc., New York.
- 47 Levine, E.M., Becker, Y., Boone, C.W. and Eagle, H. (1965) Contact inhibition, macromolecular synthesis, and polyribosomes in cultured human diploid fibroblast. *Proc. Natl. Acad. Sci. USA* 53, 350-356.
- 48 Gilula, N.B., Fawcett, D.W. and Aoki, A. (1976) The Sertoli cell occluding junctions and gap junctions in mature and developing mammalian testis. *Dev. Biol.* 50, 142-168.
- 49 McGinley, D.M., Posalaky, Z., Porvasnik, M. and Russell, L. (1979) Gap junctions between Sertoli and germ cells of rat seminiferous tubules. *Tissue and Cell* 11, 741-754.
- 50 Schultz, R.M. (1985) Roles of cell-to-cell communication in development. *Biol. Reprod.* 32, 27-42.
- 51 Loch-Caruso, R. (1987) Alteration of gap junctions as potential mechanism of reproductive toxicity. In: H.A. Milman and E. Elmore (Eds.), *Biochemical Mechanisms and Regulation of Intercellular Communication*. Princeton Scientific Publ., Princeton, New Jersey, pp. 137-149.
- 52 Iverson, O.H. (1981) The chalcones. In: R. Baserga (Ed.), *Handbook of Experimental Pharmacology*, Vol. 57, Springer-Verlag, Berlin, pp. 491-550.
- 53 Madhukar, B.V., Oh, S.Y., Chang, C.C., Wade, M. and Trosko, J.E. (In Press) Altered regulation of intercellular communication by epidermal growth factor, transforming growth factor- $\beta$ , and peptide hormones in normal human keratinocytes. *Carcinogenesis*.
- 54 Larsen, W.J. and Risinger, M.A. (1985) The dynamic life histories of intercellular membrane junctions. *Mod. Cell. Biol.* 4, 151-216.
- 55 Yamasaki, H., Hollstein, M., Mesnil, M., Martel, N. and Aguelon, A.M. (1987) Selective lack of intercellular communication between transformed and nontransformed cells as a common property of chemical and oncogene transformation of BALB/c3T3 cells. *Cancer Res.* 47, 5658-5664.



- 56 Trosko, J.E., Chang, C.C., Madhukar, B.V., and Ho, S.Y. (1990) Chemical, oncogene, and growth regulator modulation of extracellular, intercellular, and intercellular communication. *Cell Intercommunication*, ed. W.C. DeMello pp. 111-131.
- 57 Newbold, D.F. and Overell, R.W. (1983) Fibroblast immortality is a prerequisite for transformation by EJ c-Ha-ras oncogenes. *Nature* 304, 648-651.
- 58 Land, H., Parada, L.F. and Weinberg, R.A. (1983) Tumorigenic conversion of primary embryo fibroblasts requires at least two cooperating oncogenes. *Nature* 304, 596-602.
- 59 Yamasaki, H. and Katoh, F. (1988) Further evidence for the involvement of gap-junctional intercellular communication in induction and maintenance of transformed foci in BALB/c3T3 cells. *Cancer Res.* 48, 3490-3495.
- 60 Yancey, S.B., Edens, J.E., Trosko, J.E., Chang, C.C. and Revel, J.P. (1982) Decreased incidence of gap junctions between Chinese hamster V79 cells upon exposure to the tumor promoter, TPA. *Exp. Cell Res.* 139, 329-340.
- 61 Kalimi, G.H. and Sirsat, S.M. (1984) The relevance of gap junctions to stage I tumor promotion in mouse epidermis. *Carcinogenesis* 5, 1671-1677.
- 62 Jansen-Timmen, U., Traub, O., Dermietzel, R., Rabes, H.M. and Willecke, K. (1986) Reduced number of gap junctions in rat hepatocarcinomas detected by monoclonal antibody. *Carcinogenesis* 7, 1475-1482.
- 63 Sugie, S., Mori, H. and Takahashi, M. (1987) Effect of *in vivo* exposure to the liver tumor promoters, phenobarbital or DDT on the gap junctions of rat hepatocytes: A quantitative freeze-fracture analysis. *Carcinogenesis* 8, 45-51.
- 64 Beer, D.G., Neveu, M.J., Paul, D.L., Rapp, U.R. and Pitot, H.C. (1988) Expression of the c-ras protooncogene 8-glutamyltranspeptidase, and gap junction protein in rat liver neoplasms. *Cancer Res.* 48, 1610-1617.
- 65 Trosko, J.E., Chang, C.C. and Medcalf, A. (1983) Mechanisms of tumor promotion: Potential role of intercellular communication. *Cancer Invest.* 1, 511-526.
- 66 Iijima, N., Yamamoto, T., Inoue, K., Soo, S., Matsuzawa, A., Kanno, Y. and Matsui, Y. (1969) Experimental studies on dynamic behavior of cells in subcutaneous solid tumor (MH 134-C3H/He). *Japan J. Exp. Med.* 39, 205-221.
- 67 Nicolson, G.L., Dulski, K.M. and Trosko, J.E. (1988) Loss of intercellular junctional communication correlates with metastatic potential in mammary adenocarcinoma cells. *Proc. Natl. Acad. Sci. USA* 85, 473-476.
- 68 Hamada, J., Takeichi, N. and Kobayashi, H. (1988) Metastatic capacity and intercellular communication between normal cells and metastatic cell clones derived from a rat mammary carcinoma. *Cancer Res.* 48, 5129-5132.
- 69 Azarnia, R., Reddy, S., Kimieki, T.E., Shalloway, D. and Loewenstein, W.R. (1988) The cellular src gene product regulates junctional cell-to-cell communication. *Science* 239, 398-401.

- 70 Trosko, J.E. and Chang, C.C. (1983) Potential role of intercellular communication in the rate-limiting step in carcinogenesis. In: J.A. Cimino (Ed.), *Cancer and Environment*, Mary Ann Liebert, Inc., New York, pp. 6-22.
- 71 Trosko, J.E. and Chang, C.C. (1985) Role of tumor promotion in affecting the multi-hit nature of carcinogenesis. In: A.D. Woodhead, C.J. Shellabarger, V. Pond, and A. Hollaender (Eds.), *Assessment of Risk from Low-Level Exposure Radiation and Chemicals*. Plenum Press, New York, pp. 261-281.
- 72 Warngard, L., Flodstrom, S., Ljungquist, S. and Ahlborg, U.G. (1987) Interaction between quercetin, TPA and DDT in the V79 metabolic cooperation assay. *Carcinogenesis* 8, 1201-1205.
- 73 Aylsworth, C.F., Trosko, J.E., Chang, C.C. and Benjamin, K. (In Press) Synergistic inhibition of metabolic cooperation by oleic acid or 12-O-tetradecanoylphorbol-13-acetate and dichlorodiphenyltrichlorethane in Chinese hamster V79 cells: Implications of a role for protein kinase C in the regulation of gap junctional intercellular communication. *Cell Biol. Toxicol.*
- 74 Williams, G.M. (1984) Modulation of chemical carcinogenesis by xenobiotics. *Fund. Appl. Toxicol.* 4, 325-344.

## HETEROGENEITY OF ENZYME-ALTERED FOCI IN RAT LIVER

Michael Schwarz, Albrecht Buchmann, Martina Schulte, Dale Pearson, and Werner Kunz

*German Cancer Research Center, Institute of Biochemistry,  
Im Neuenheimer Feld 280, 6900 Heidelberg, FRG*

### SUMMARY

Enzyme-altered foci (EAF) in liver are assumed to be precursor lesions for tumors in this organ. Results obtained with selected hepatocarcinogens which produce lesions of differing phenotype and growth behavior indicate that not the total number of enzyme-altered cells, but rather, the proliferation of individual cell clones is of major importance for additional changes leading to malignancy. Analyses including multiple marker enzymes demonstrate a relationship between foci phenotype and proliferation. The inducibility of certain down-regulated enzymes in EAF indirectly suggests disturbances in the expression of regulatory genes such as protooncogenes. Data on Ha-ras and c-myc protooncogene expression in EAF are presented.

### INTRODUCTION

It is generally assumed that the carcinogenic process includes at least two rate-limiting changes within the target cell population. These changes are mostly regarded as mutational events leading to irreversible alterations of genetic materials that can be inherited to daughter cells [1]. Based on this assumption, the velocity of the carcinogenic process is governed by the (low) probability of such mutational events within critical regulatory genes. However, as has been pointed out and set into a mathematical framework by Moolgavkar [2,3], the kinetics of cell birth and death of intermediate cell populations during this process may also play a very important role [4].

Chemically induced hepatocarcinogenesis in rodents is an extremely useful tool to study qualitative and quantitative changes occurring during the carcinogenic process. Shortly after exposure to a hepatocarcinogen, foci of cells characterized by changes in the expression of several marker enzymes appear in the liver of the experimental animals [5-20]. These focal lesions have been demonstrated to be monoclonal in origin [21,22] and to display increases in cell proliferation in comparison to the normal hepatocytes [10,23]. There is accumulating evidence to suggest that at least some of these early enzyme-altered foci are precursor lesions that are causally related to the malignant process. This is substantiated by the sequential appearance of the enzyme-altered foci and the liver tumors and by the fact that these lesions and the later-appearing neoplastic nodules and tumors have in common alterations in certain marker enzymes [24]. Moreover, quantitative relationships between the development of enzyme-altered foci in liver and subsequent tumor manifestation in this organ have been demonstrated for a variety of hepatocarcinogens [4,17,25-27].

The analysis of multiple enzyme markers demonstrates a marked heterogeneity of phenotypes between individual foci [11,15,16,18,19,28,29]. Such diversity also can be observed when analyzing the growth properties of individual lesions. This evidence is relevant for carcinogenicity models which consider growth of intermediate cell populations as an important factor during the carcinogenic process because it demonstrates that enzyme-altered cells of focal liver lesions are not a homogeneous population of "initiated" intermediated cells, but rather, represent a pool of cells with differing biological fate. In the present paper we report on qualitative and quantitative data obtained in experiments designed to differentiate foci with characteristically differing phenotype and growth behavior with the aim to study the relevance of these parameters for the process of malignant transformation in liver.

## **MATERIALS AND METHODS**

### ***Treatment of Animals***

Female Wistar rats were used throughout the experiments. Animals were obtained from the Zentralinstitut für Versuchstierkunde (Hannover, FRG) and kept, unless specified otherwise, on a standard diet of Altromin pellets (Altromin, Lage, FRG) and water ad libitum. Carcinogens were administered in the drinking water or diet at the dose levels and time periods indicated in the text. 4-Dimethylaminoazobenzene (4-DAB) was always given in a riboflavin-poor diet in order to prevent loss of carcinogenic activity due to the rapid decomposition in liver by azoreductase activity. The age of rats at the start of the carcinogen treatment varied between four to eight weeks for the different experimental setups.

### ***Enzyme- and Immunohistochemistry***

Animals were sacrificed under ether anesthesia. Livers were removed carefully and immediately frozen at -40°C. Serial sections of 10 µm were prepared on a cryostat microtome and used for enzyme- and immunohistochemical staining procedures. Adenosin triphosphatase (ATPase) activity was demonstrated according to the method of Wachstein and Meisel [30], with slight modifications, and  $\gamma$ -glutamyltranspeptidase (GGT) activity according to Lojda et al. [31]. For PAS reaction (glycogen stain), the procedure of Hotchkis [32] was followed. Immunohistochemical staining for different drug-metabolizing enzymes and NADP-dependent reduction of nitro blue tetrazolium (stain for NADPH-cytochrome P-450 reductase) was performed as previously described [15]. Antibodies used in this study against four different cytochrome P-450 isozymes (PB1, PB2, MC1, and MC2 [33]), NADPH-cytochrome P-450 reductase, and the glutathione transferases B and C were made available for use by the groups of Dr. R. Wolf (Imperial Cancer Research Fund, Laboratory of Molecular Pharmacology and Drug Metabolism, Edinburgh, UK) and Dr. F. Oesch (Institute of Toxicology, University of Mainz, FRG).

### **In Situ Hybridization and Northern Analysis of RNA**

The *in situ* hybridization of frozen liver sections with <sup>35</sup>S-labeled cDNA probes were performed as recently described [34]. R17 cDNA [35] and TF1 cDNA probes [36] were obtained from Dr. T. Friedberg (Institute of Toxicology, University of Mainz, FRG). Ha-*ras* cDNA [37] was from Dr. A. Balmain (Beatson Institute for Cancer Research, Glasgow, UK); and *c-myc* cDNA [38] was from Dr. H.C. Pitot (McArdle Laboratory for Cancer Research, Madison, Wisconsin, USA).

For Northern analysis, total cellular RNA was isolated, separated on 1.2% agarose gels, transferred to Gene Screen Plus membranes, and hybridized with nick-translated, <sup>32</sup>P-labeled cDNA probes essentially as described in Maniatis et al. [39].

### **Ha-Ras Mutation Analysis**

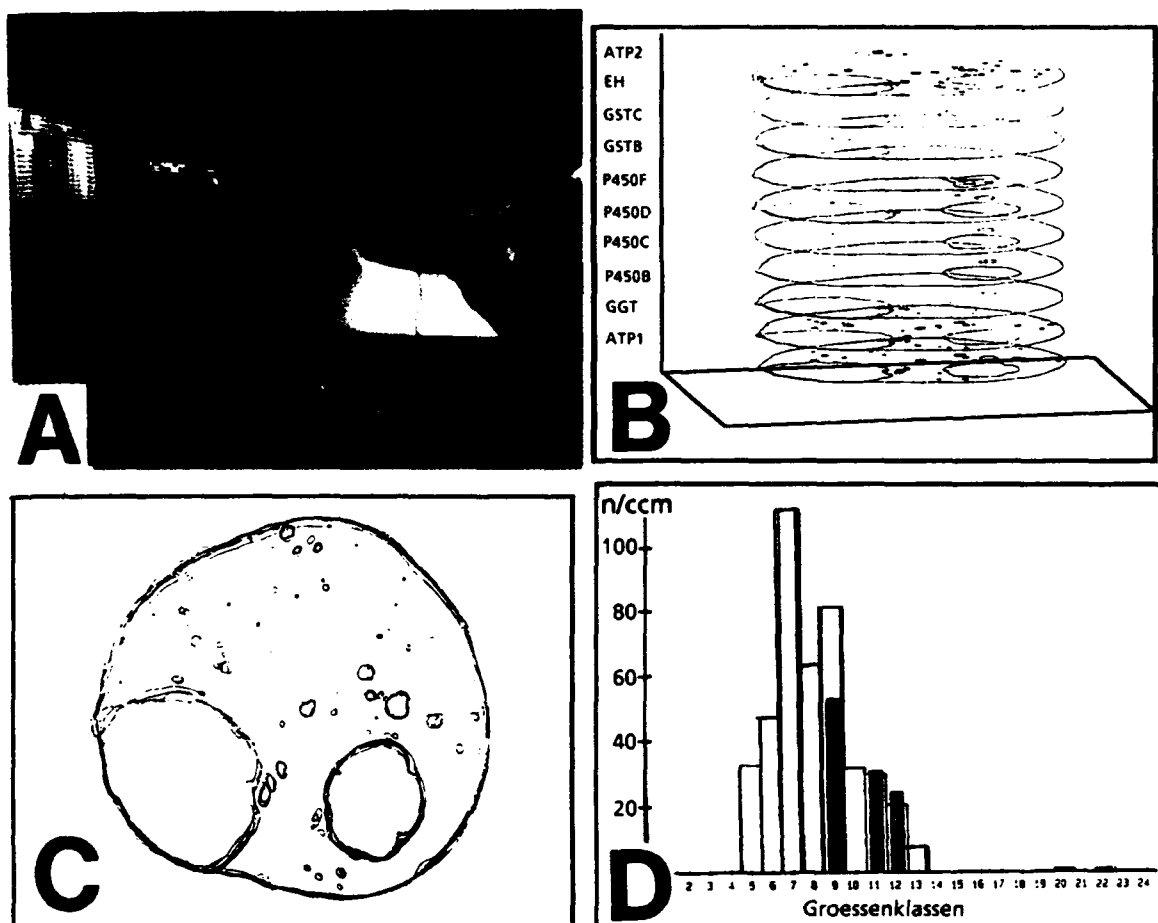
For analysis of Ha-*ras* mutations in codon 12 and 61, two strategies were followed. In the first, restriction fragment length polymorphism analysis was employed to detect A->T transversion mutations at codon 61 of the Ha-*ras* gene which is known to create a new Xba1 restriction site [40]. Genomic DNA was isolated, restricted with Xba1, separated on agarose gels, and transferred to Gene Screen Plus membrane [39]. Ha-*ras* specific DNA sequences were then detected following hybridization with the <sup>32</sup>P-labeled BS9 clone.

In the second strategy, 1 µg of genomic DNA was amplified *in vitro* by the polymerase chain reaction using TAQ polymerase [41]. Specific primers and oligonucleotide probes were obtained from Dr. A. Balmain (Beatson Institute for Cancer Research, Glasgow, UK). The primer used for amplification yielded DNA-fragments of 138 bp of Ha-*ras* exon 1 (codon 12). After amplification, mutations in the Ha-*ras* protooncogene were analyzed by selective oligonucleotide hybridization using <sup>32</sup>P-labeled oligonucleotide probes [42].

## **RESULTS AND DISCUSSION**

### **Quantitation of EAF**

Enzyme-altered lesions appear early during hepatocarcinogenesis and can be quantitated accurately. Since EAF develop monoclonally [21, 22], the number of EAF per liver gives a measure of the number of single (initiated) cells from which these lesions originate. The number of foci in the three-dimensional space can only be indirectly assessed on the basis of data on the number and size distribution of foci transections. For computer-assisted analysis, a system was developed that shares some similarities with the one described by Campbell et al. [43]. Some details of the system are shown in Figure 1. Stained liver sections are projected from the rear onto a digitizer screen where the outlines of the sections and of lesions showing enzyme deviations are traced manually with a cursor. The calculation of the number of foci in the three-dimensional space, the size-distribution of lesions, and their volumetric fraction in liver is then performed using stereological procedures [44].



**Figure 1. A: Analysis System for Quantitation of EAF in Liver. B: Computer-Assisted Three-Dimensional Reconstruction of Serial Liver Sections Stained for Different Marker Enzymes. C: Overlays of the Series of Liver Sections Shown in B as Performed by Computer. D: Computer Plot of the Size Distribution of Foci of a Selected Phenotype as Compared to the Size Distribution of Foci of the "Leader Stain" (for further details see text.)**

Following computer-assisted three-dimensional reconstruction of up to 10 serial sections stained for different marker enzymes, the same parameters then can be obtained for any phenotype of interest. Generally, the first and last section of the series were stained for the same marker, in most instances ATPase, to ensure that all marker deviations laying in between are, at least in principle, observable. In these experiments, stereological calculations were performed on the basis of data obtained with the ATPase marker, which served as a "leading stain" of the series.

#### ***EAF and Liver Tumors***

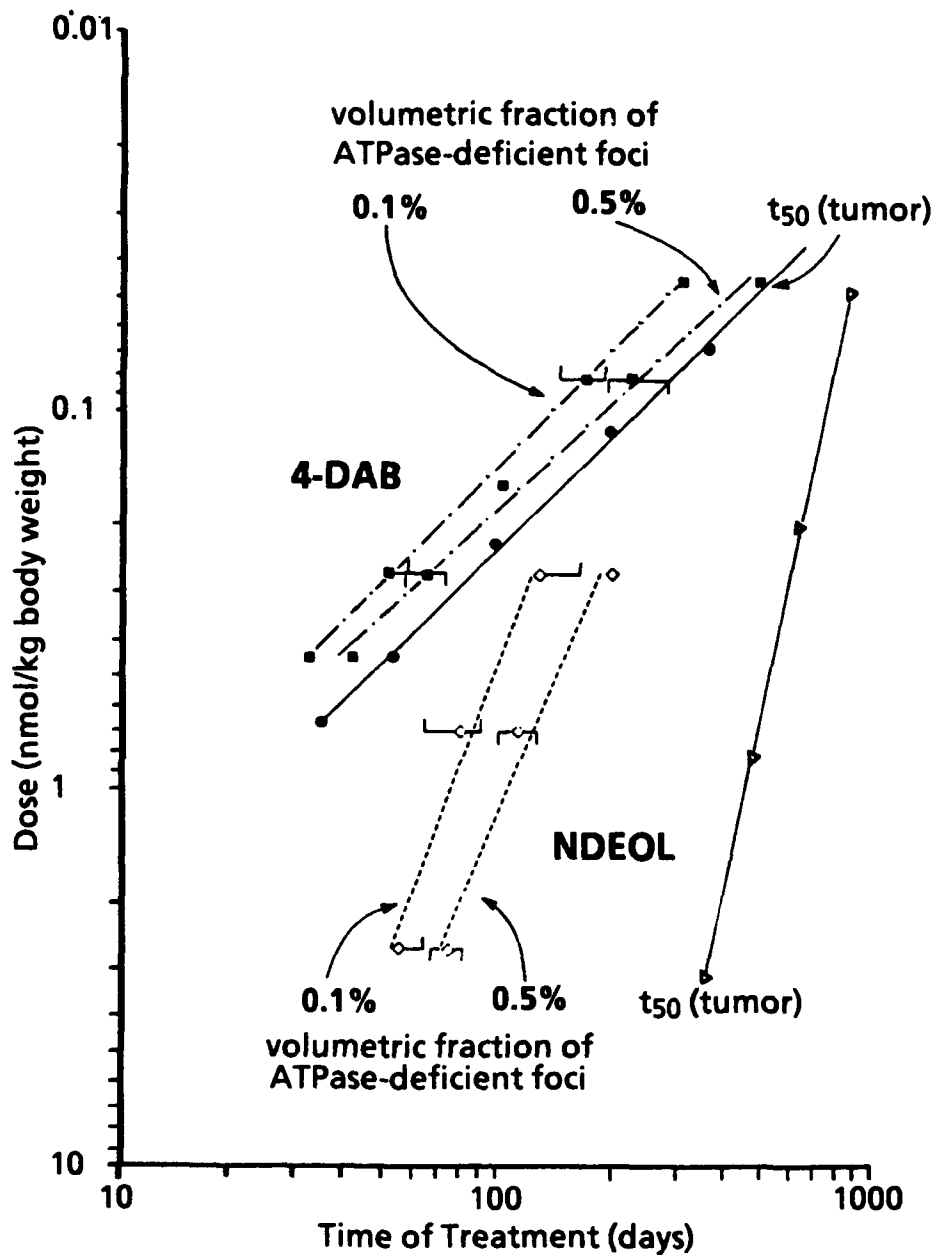
As has already been pointed out in the introduction, there are several lines of evidence to suggest that enzyme-altered foci in liver are precursors to tumors in this organ. In a series of experiments on the role of enzyme-altered cells as intermediate cell populations during hepato-

carcinogenesis, we have focused our interest on two hepatocarcinogens: 4-DAB, also known as butter yellow, and *N*-nitrosodiethanolamine (NDEOL). Druckrey already used 4-DAB in the 1950s in studies on the effects of continuous and discontinuous exposure of rats to this carcinogen [45]. In his pioneering investigation, Druckrey could establish for this and a large number of additional carcinogens quantitative relationships between daily exposure levels and median tumor induction times ( $t_{50}$ ) which yielded straight lines when plotted in a double-logarithmic net with slopes being characteristic for the carcinogen under investigation. The carcinogenic potency of NDEOL has been investigated in detail by Preussmann et al. [46].

On the basis of data on the development of ATPase-deficient foci in livers of rats treated continuously with 4-DAB and NDEOL, it was possible to show a quantitative relationship between the extent of enzyme-altered tissue produced by these carcinogens and the subsequent development of liver tumors. This is demonstrated in Figure 2 by the similarity of the slopes of the regression lines describing the dose dependence of the induction of defined volumes of ATPase-deficient foci (in this case 0.1% and 0.5% enzyme-altered tissue in liver) and the induction of liver tumors. Similar results have recently been reported for NDEOL [47].

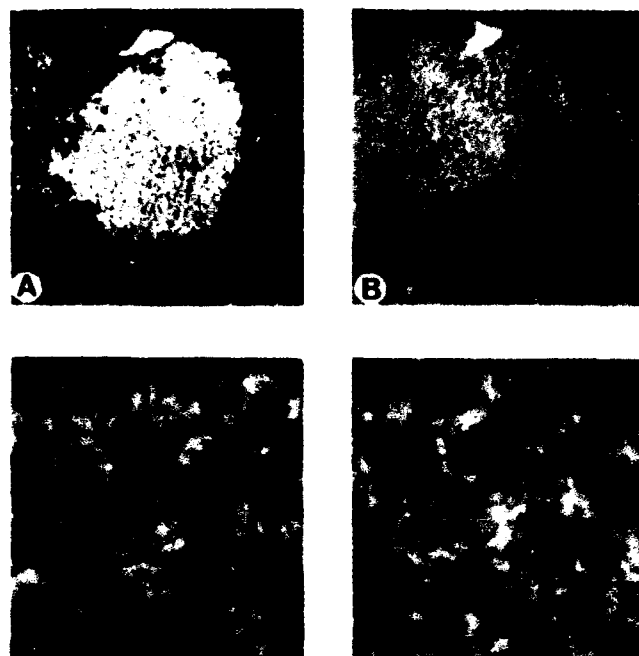
4-DAB and NDEOL show striking differences with respect to their dose-time relationships of liver tumor induction (see Figure 2). Within the given dose range, doubling the daily exposure levels of 4-DAB will cut the median tumor induction time by half. In contrast, an approximately 50-fold increase in daily dose level is necessary with NDEOL to obtain the same effect. As a consequence, 4-DAB is a very potent carcinogen at a high dose level, resulting in extremely short tumor induction times, but it becomes a weak carcinogen when the dose level is lowered by just one order of magnitude (see Figure 2). In other words, the carcinogenic response obtained with 4-DAB is strongly dose dependent. With NDEOL, however, tumor induction times are much longer, even at the higher dose levels, and the carcinogenic response is considerably less affected by changes in dose.

A second very characteristic difference between the two carcinogens became obvious when analyzing the time periods between the induction of early enzyme-altered foci and liver tumors. These time periods were very long for NDEOL but much shorter for 4-DAB. From this we concluded that 4-DAB may possess a dose-related potency to accelerate the process from the early enzyme-altered foci to the liver tumors; an activity that we referred to as "intrinsic promoting" activity [26,48]. NDEOL seems to lack such an activity. However, foci initiated by NDEOL treatment can be effectively promoted by subsequent 4-DAB administration [48]. Promotion of the carcinogenic process by 4-DAB is assumed to be mediated by a strong stimulatory effect of this compound on the growth of enzyme-altered foci. This is substantiated by the fact that enzyme-altered cells within liver foci generated by continuous 4-DAB treatment show a high labeling index following short-term administration of  $^3\text{H}$ -thymidine, indicating ongoing DNA synthesis in these cells (see Figure 3).



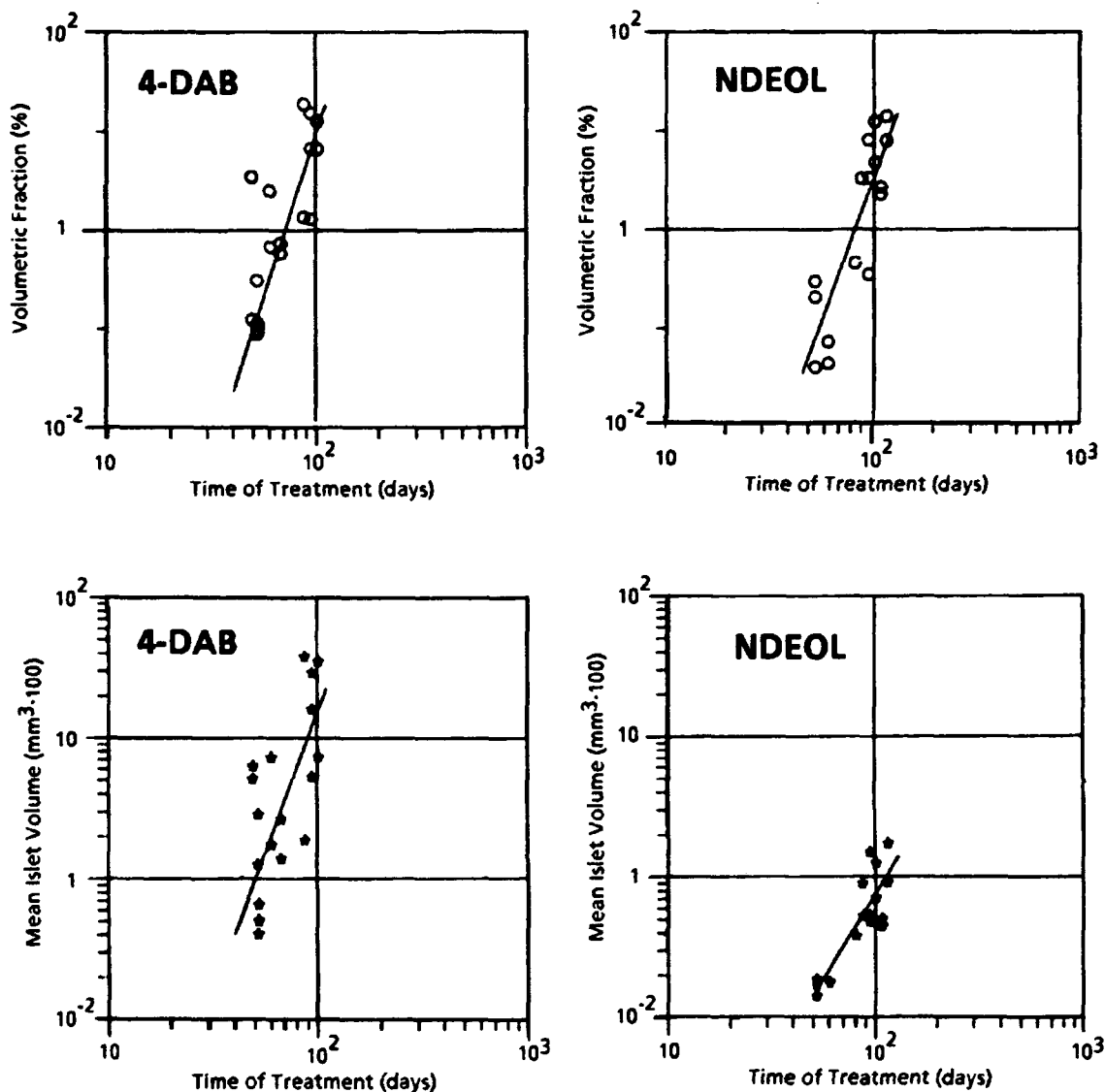
**Figure 2.** Dose-Time Relationships for the Induction of Liver Tumors and Defined Fractions of ATPase-Deficient Foci in Rat Liver by 4-DAB and NDEOL. Liver tumor data are taken from the literature (4-DAB, NDEOL [45, 46, respectively]). For the analysis of preneoplastic response, rats were treated continuously with different doses of the hepatocarcinogens. Rats were sacrificed sequentially and the time period necessary to reach defined fractions of enzyme-altered tissue in liver (0.1% or 0.5%, respectively) were calculated for each dose group by regression analysis of the time-dependent increases in the volumetric liver fraction of ATPase-deficient foci





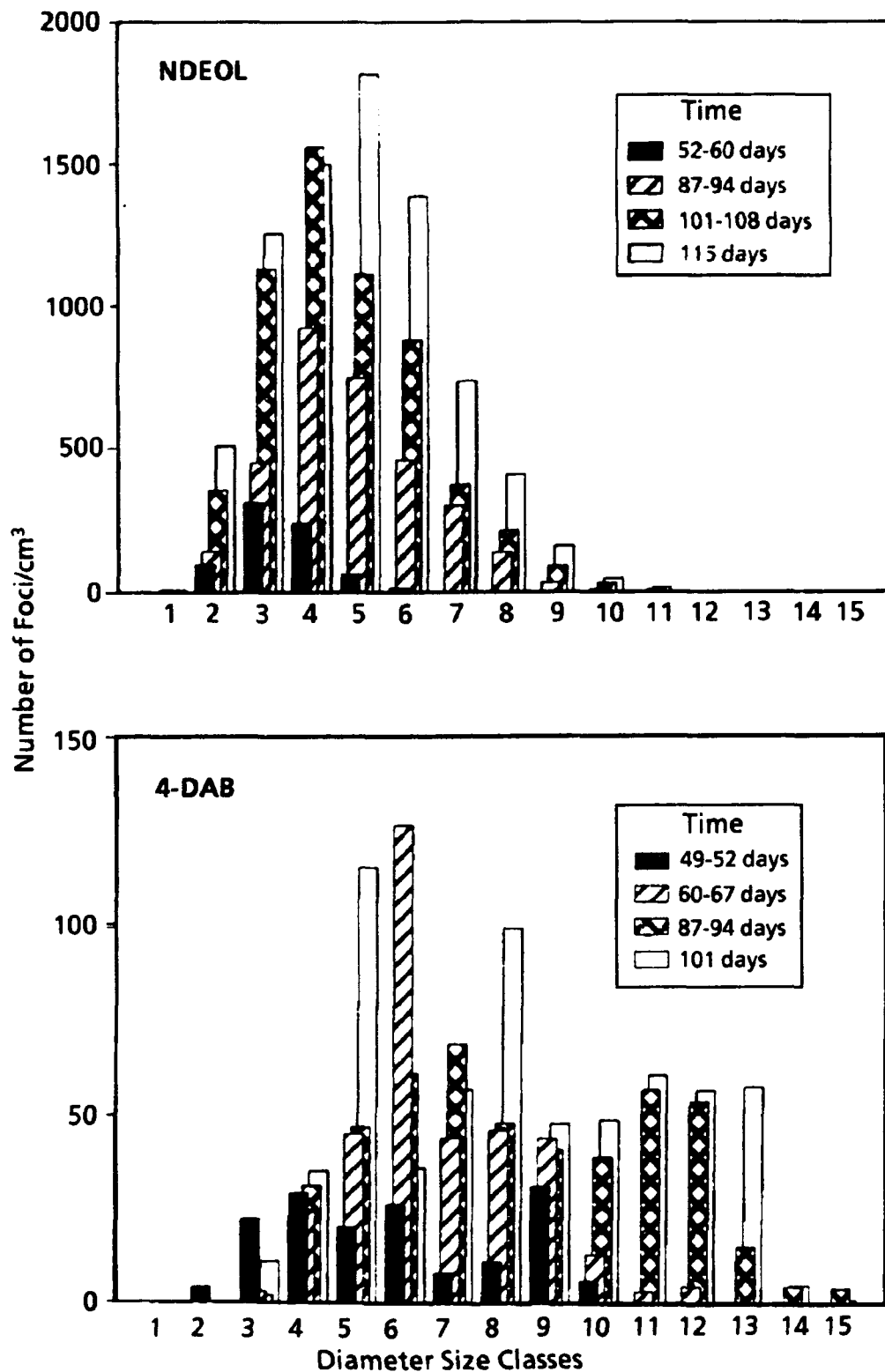
**Figure 3.**  $^3\text{H}$ -Thymidine Incorporation into DNA of Hepatocytes from an Enzyme-Altered Focus Generated in Rat Liver by Administration of 4-DAB (0.06% in diet) for 100 Days. Rats were given three ip injections of methyl- $^3\text{H}$ -thymidine ( $3 \times 30 \mu\text{Ci}/\text{rat}$ ) on two consecutive days prior to killing. Frozen liver sections were coated with photo emulsion and developed after five days of exposure. Sections were counterstained with H&E. Parallel frozen sections were stained for ATPase as reference. A: ATPase-negative focus. B: H&E stain of the same lesion. The lower two photomicrographs show autoradiographic pictures of the lesion at higher magnification.

The difference between 4-DAB and NDEOL in their potency to enhance the growth of enzyme-altered lesions in liver can be taken from data shown in Figure 4. At dose levels of 0.06% of 4-DAB in diet and 0.2% of NDEOL in drinking water, there was an almost identical increase in the volumetric fraction of ATPase-deficient tissue in liver as a function of time of treatment with these carcinogens. Therefore, with respect to this parameter, these two selected dose levels of 4-DAB and NDEOL are almost equipotent. However, the increase in the volumetric fraction of EAF was, in the case of NDEOL, predominantly mediated by an enhancement of *foci number*, indicating comparatively strong initiating potency [48], whereas with 4-DAB, it was mostly due to the enhancement of individual *foci size*. As a result, the mean islet volume of foci generated by continuous 4-DAB treatment was at all times points larger than those induced by NDEOL, being about 10 times higher at 100 days of treatment (see Figure 4). The differences in number and size of foci generated by the two selected doses of 4-DAB and NDEOL also are reflected by the size class distributions of the lesions, which are shown in Figure 5. The number of ATPase-deficient foci (sum of foci within the different size classes) was always by far higher with NDEOL than with 4-DAB when estimated at different time intervals during continuous treatment with these carcinogens. The higher foci diameter classes, between 12 and 15 (630 to 1560  $\mu\text{m}$ ), however, were only occupied in 4-DAB-treated animals.



**Figure 4.** Development of ATPase-Deficient Foci in Livers of Rats Treated Continuously with 4-DAB or NDEOL. 4-DAB was given in diet at a concentration of 0.06% and NDEOL was given in drinking water at a concentration of 0.2%. Rats were sacrificed sequentially, and sections were taken from frozen liver blocks and stained for ATPase activity. Upper two graphs: Relative fraction of enzyme-altered tissue in liver. Lower two graphs: Mean islet volume. Each point represents a value from one animal; regression lines also are given to facilitate comparison of data [48].

The results described so far demonstrate remarkable differences in the effects of 4-DAB and NDEOL on the development of enzyme-altered foci in liver. At dose levels leading to an approximately equivalent mass of enzyme-altered cells, NDEOL treatment produces numerous but small liver foci, whereas continuous administration of 4-DAB results in the induction of comparatively few but rapidly growing liver lesions. Since the time periods between the induction of early enzyme-altered lesions and the induction of liver tumors were very short with 4-DAB and much longer with



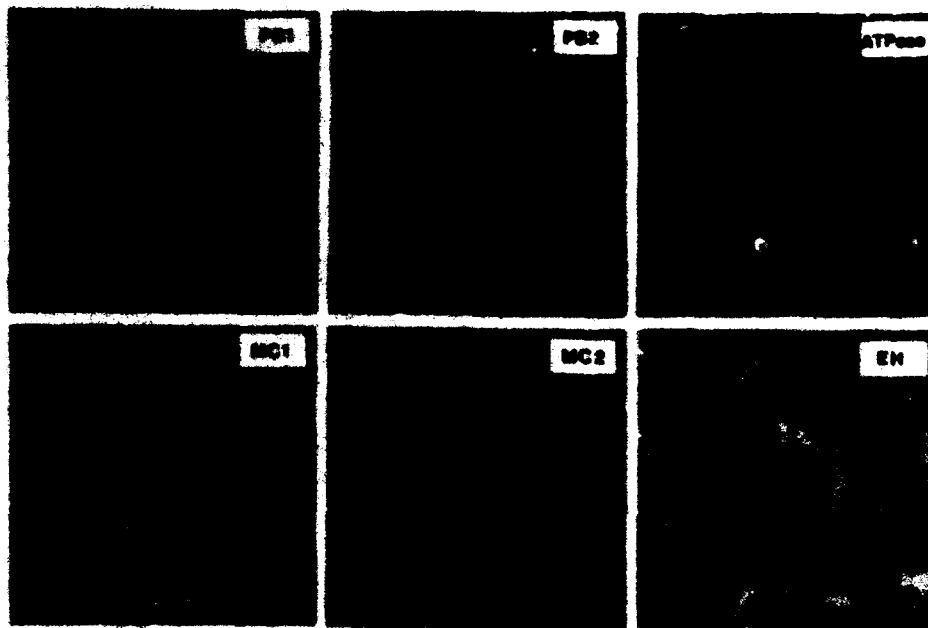
**Figure 5. Size Distributions of ATPase-Deficient Foci in Livers of Rats Treated with 4-DAB or NDEOL.** For treatment see legend to Figure 4. The histograms show the mean number of foci in the different size classes. Diameter classes 1 to 15 range from 50 to 1260  $\mu\text{m}$ , increasing logarithmically.

NDEOL (see Figure 2), it can be concluded that the probability of changes leading from the tumor progenitor cells to the tumor cells is somewhat related to the growth properties of individual preneoplastic cell clones, and not simply to the total number of intermediate cells. This points directly to a heterogeneity of these precursor lesions.

#### **PHENOTYPE DIVERSITY OF EAF**

Differences in the marker enzyme patterns of enzyme-altered foci could principally be used for a subclassification of enzyme-altered precursor populations into lesions of differing biological fate and malignant potency. Changes in foci phenotype occurring during chemical carcinogenesis were studied in detail in stop experiments with DEN. Besides "classical" markers such as ATPase and v-glutamyltranspeptidase, enzymes of the drug-metabolizing system were included in our analyses of foci phenotypes. The contents of four different cytochrome P-450 isozymes as well as of phase II enzymes of the drug-metabolizing system were determined in liver lesions and the surrounding normal tissue by use of immunohistochemical staining procedures. Characteristic changes in the expression levels of some of these enzymes during the process of hepatocarcinogenesis were observed and are reported elsewhere in more detail [15,16,18]. In these studies, "early" enzyme-altered foci appearing shortly after stop of a limited DEN exposure of rats showed unchanged or even slightly increased cytochrome P-450 levels. During the subsequent time course of carcinogenesis, various P-450 isozymes started to decline and expansively growing neoplastic nodules were generally characterized by decreases in all four cytochrome P-450 isozymes investigated. An example of such a lesion is shown in the photomicrograph in Figure 6.

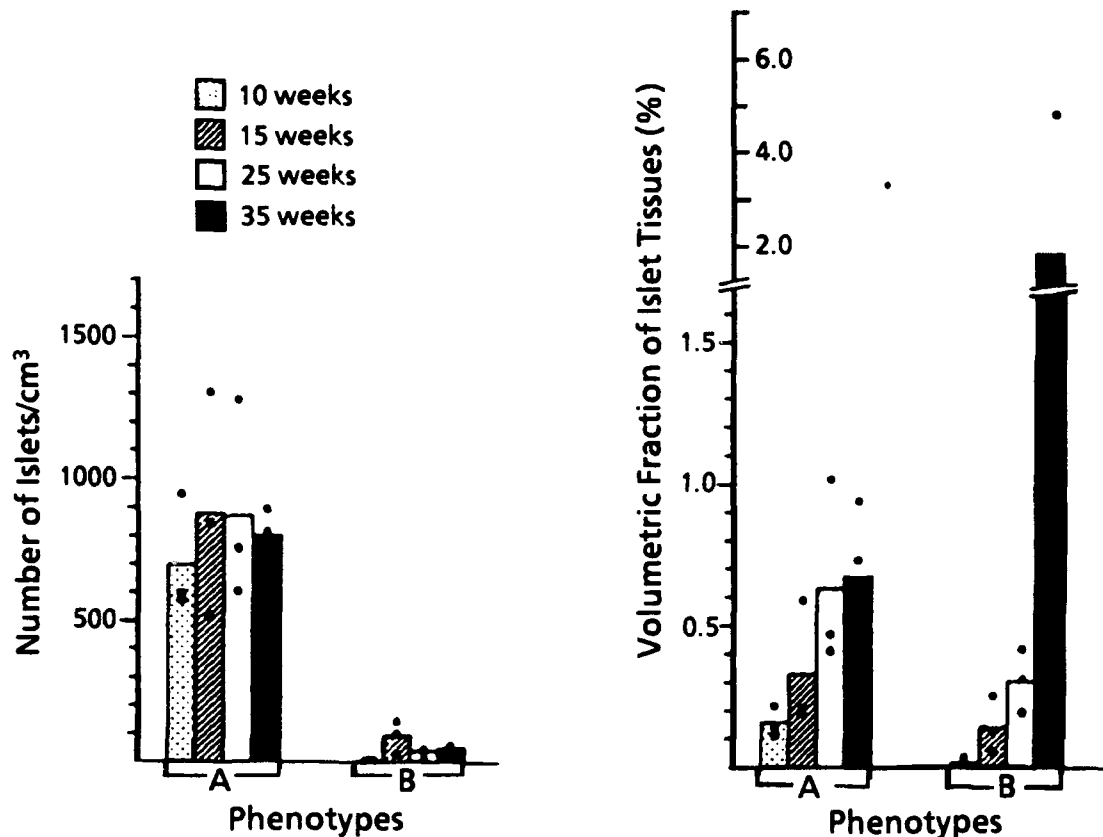
Data on lesions of two selected phenotypes observed at various time points after stop of DEN treatment of rats are given in Figure 7. The number of foci showing ATPase deficiency without additional changes in any of the other markers investigated (ATPase only) was high and did not change significantly during the experiment. In contrast, the number of lesions characterized by a decrease in three or four cytochrome P-450 isozymes was comparatively small. Lesions of this latter phenotype, however, showed a dramatic increase in their volumetric fraction of liver tissue with progression of time, thus indicating a strong growth advantage over foci with ATPase change only (see Figure 7). The frequency of lesions of the different phenotypes varied also between 4-DAB and NDEOL. With NDEOL, the number of lesions showing ATPase deficiency only was much higher than with 4-DAB. In contrast, continuous 4-DAB treatment led to a comparatively large number of lesions exhibiting changes in the expression of ATPase, along with a decrease in the level of four cytochrome P-450 isozymes [49]. These findings demonstrate a relationship between phenotype and growth of lesions produced under various conditions.



**Figure 6. Immunohistochemical Demonstration of Four Cytochrome P-450 Isozymes (PB1, PB2, MC1, MC2), and Microsomal Epoxide Hydrolase (EH) in Serial Frozen Sections of a DEN-Treated Rat. The animal was given DEN (3 mg/kg body weight) for eight weeks and was killed 11 weeks later. ATPase: activity stain for canalicular adenosine-triphosphatase.**

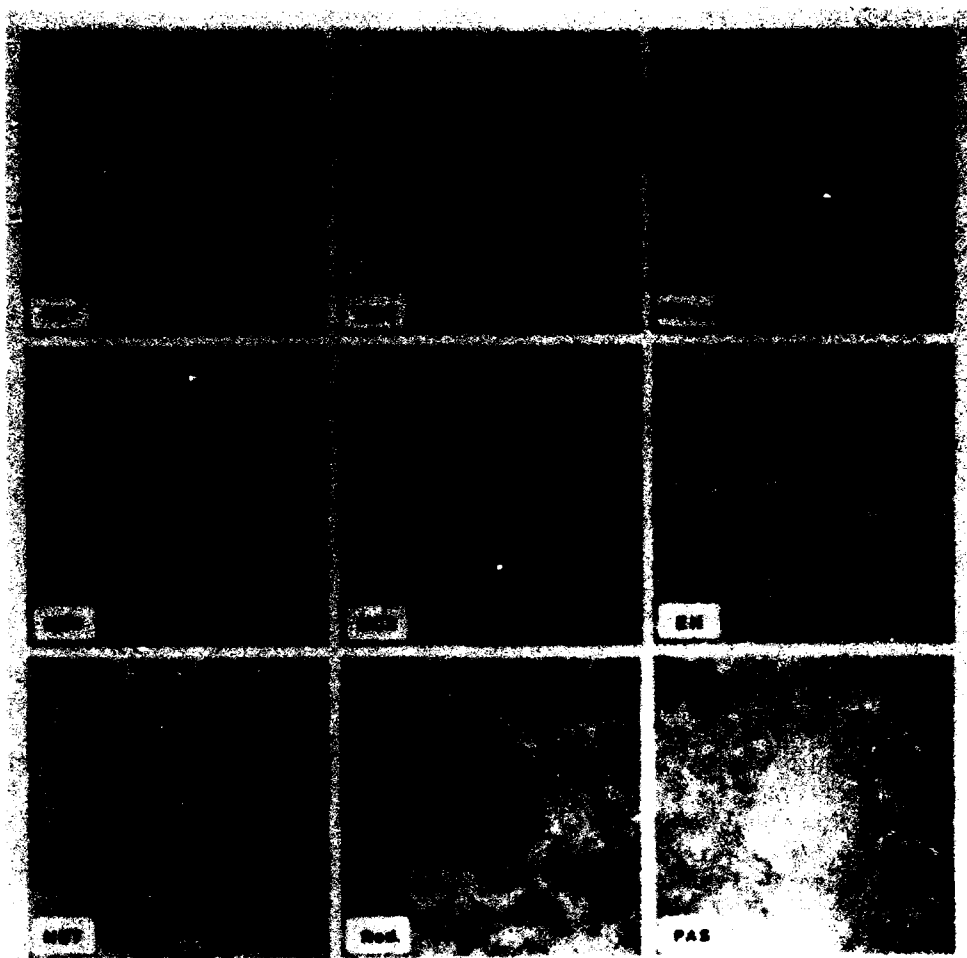
#### ***Induction of Cytochrome P-450 in EAF***

Changes in the cytochrome P-450 system observed in hepatocellular nodules may well serve as phenotypic markers of the carcinogenic process but are not necessarily causally related to this process. This follows indirectly from the observation that the expression of certain cytochrome P-450 isozymes which are decreased in expansively growing nodules can still be elevated by typical inducers of the enzyme system such as phenobarbital (PB) or 3-methylcholanthrene [16,18,50]. This is exemplified in a photomicrograph series in Figure 8, showing a neoplastic nodule in rat liver which was induced by limited DEN exposure followed by continuous PB treatment of the animal until sacrifice. Within this lesion, the PB-inducible cytochrome P-450 isozymes PB1 and especially PB2 clearly were elevated to levels comparable to that of the subpopulations of liver cells around the central veins that respond to the inducing stimulus of the xenobiotic. A concomitant increase in the NADPH (cytochrome P-450) reductase was always observed.



**Figure 7. Development of Different Foci Phenotypes in Rat Liver Following Limited DEN Exposure.** DEN (50 to 100 ppm) was given in drinking water for 10 days. Because there was no significant difference between treatments, values were combined for calculation. Carcinogen-induced foci were subdivided into two phenotypes. A: Lesions showing a decrease in the marker enzyme ATPase without additional changes in any out of the four cytochrome P-450 isozymes investigated. B: Lesions showing ATPase deficiency plus a decrease in three or four cytochrome P-450 isozymes. Points: Values from one animal. Bars: Mean values of three animals. Foci numbers of phenotype B were significantly lower than of phenotype A ( $p = 0.002$ ). The volumetric fraction in liver of lesions of phenotype A increased linearly. In contrast, lesions of phenotype B showed a significantly different increase with about the fourth power of time as found by linear regression analysis of double-logarithmically transformed data ( $p = 0.003$ ).

The increase in enzyme protein is, at least in part, mediated by an enhancement of the steady-state concentration of the underlying messenger RNA. This can be demonstrated by *in situ* hybridization of liver sections using an appropriate cDNA probe (R17). Figure 9 shows the evaluation of mRNA specific for the PB-inducible cytochrome P-450 isozymes PB4/5 [51] in two nodules present in liver sections of a rat treated with DEN followed by the monooxygenase inducer [52]. In contrast, as is also shown in Figure 9, a concomitant decrease in mRNA coding for a constitutively expressed cytochrome P-450 isozyme was observed within the same nodules when using a cDNA probe (TF1) specific for this isozyme [36].



**Figure 8. Phenobarbital-Mediated Induction of Cytochrome P-450 Isozymes in a Rat Hepatic Nodule.** The lesion was produced in the liver of a rat treated with DEN (100 ppm in drinking water) for 10 days followed by continuous exposure to PB (0.05% in diet) until sacrifice at 17 weeks after end of DEN treatment. Four different cytochrome P-450 isozymes (PB1, PB2, MC1, MC2) were stained immunohistochemically in frozen liver sections using specific antibodies. ATPase: Adenosine triphosphatase activity stain. EH: Microsomal epoxide hydrolase (immunostain). NBT: NADPH-dependent reduction of nitro blue tetrazolium (activity stain for NADPH cytochrome P-450 reductase); Red: NADPH cytochrome P-450 reductase (immunostain). PAS: Periodic acid-Schiff reaction (staining for glycogen content).

The results obtained by *in situ* hybridization were confirmed by Northern analysis of RNA isolated from large, expansively growing liver nodules and from normal liver tissue (see Figure 10). Only in nodules from rats that were given PB until death was an increase detected in mRNA corresponding to cytochrome P-450 PB4/5 (PB-inducible forms), which was similar, although somewhat weaker, to the induction levels in the normal liver tissue. No signal, however, was detected in nodules from rats that were withdrawn from the inducer 10 days prior to killing. As was to be expected, no significant effect of PB was seen when hybridizing these RNA samples with the TF1 probe specific for the constitutively expressed P-450 (PB1) isozyme form. In accordance with the results obtained by *in situ* hybridization, some of the lesions showed reduced levels of mRNA coding for this latter cytochrome P-450 isozyme (see Figure 10).



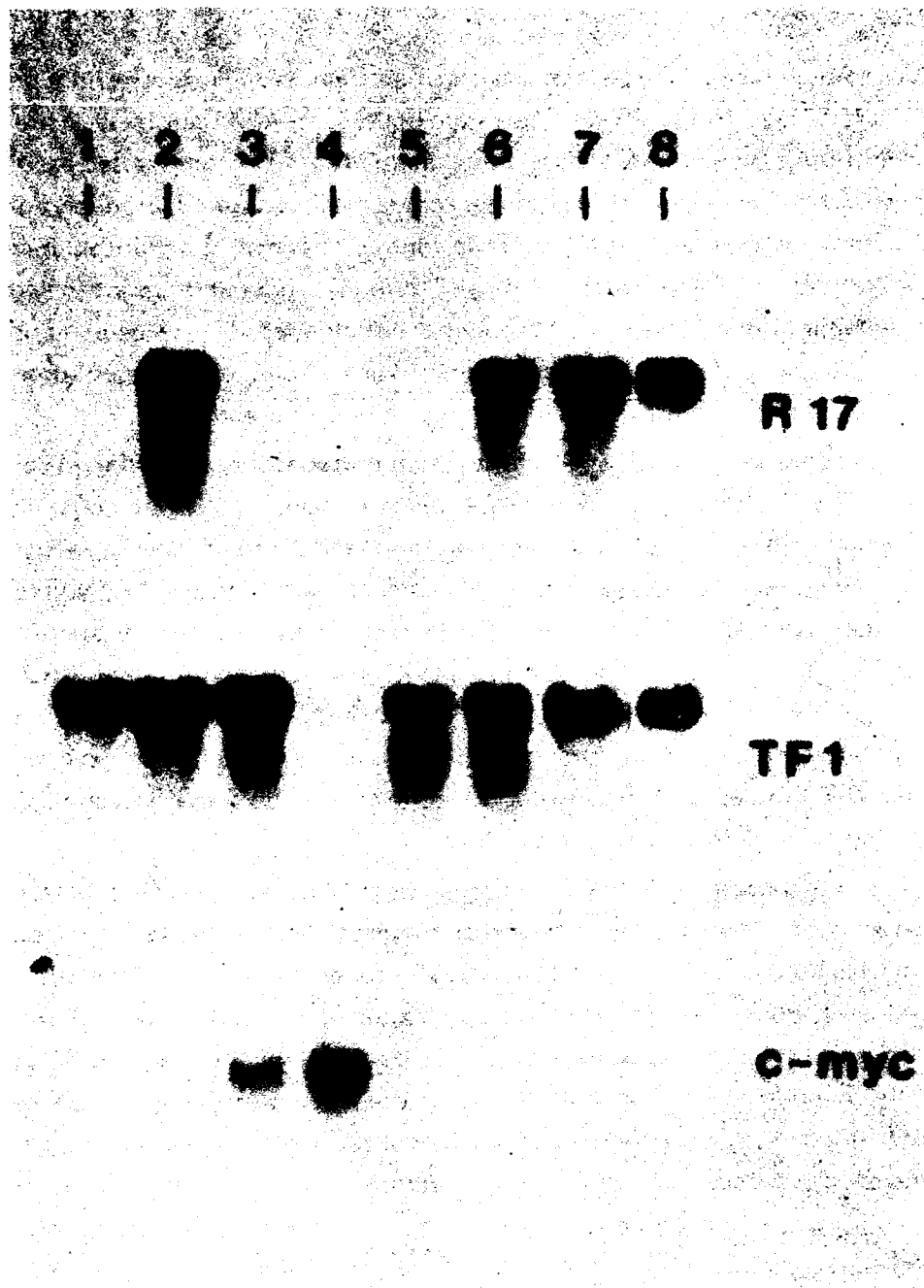
**Figure 9. Changes in Expression Levels of Cytochrome-P-450 mRNAs Within Rat Liver Nodules as Demonstrated by *In Situ* Hybridization.** The lesions were produced by administration of DEN (100 ppm in drinking water) for 10 days followed by PB (0.05% in diet) until sacrifice. Frozen liver sections were prepared and hybridized with the <sup>35</sup>S-labeled cDNA probes. Following hybridization and removal of unspecifically bound radioactivity, tissue sections were directly covered with X-ray film and exposed for five days. The photomicrographs in the figure show the autoradiograms. Note the PB-mediated increase in mRNAs coding for PB-inducible isozyme forms (R17 probe) in the two large liver nodules visible within the section and the concomitant decrease in mRNA specific for the constitutively expressed isozyme form (TF1 probe). For reference, one serial section was stained for GGT marker.

These findings clearly indicate that the changes in cytochrome P-450 expression observed in preneoplastic and neoplastic liver lesions are not a consequence of an inactivation of individual structural genes by mutational events, but rather may be related to alterations in regulatory systems of a higher order. As the so-called protooncogenes are possible candidates for such regulatory genes, we have investigated the expression of some of these genes in preneoplastic and neoplastic liver lesions. We have focused our interest on the *c-myc* and the *Ha-ras* protooncogenes because these genes have been shown to be elevated in rat liver following partial hepatectomy, thus indicating some relation to cell proliferation [53,54].

#### ***Role of Protooncogenes***

As has been recently demonstrated, there is no significant change in the expression of the *c-myc* and *Ha-ras* protooncogenes in "early" preneoplastic liver cell populations characterized by the overexpression of the marker enzyme GGT [55]. Expansively growing neoplastic rat liver nodules, however, were frequently characterized by increased expression levels of the *c-myc* gene. Interestingly, in a series of different DEN-induced nodules, the one showing the strongest increase in *c-myc* expression also exhibited the strongest decrease in mRNA specific for the constitutive form of cytochrome P-450 as detected with the TF1 probe (see Figure 10). Because high *c-myc* expression levels are generally assumed to be coupled to high cell proliferation rates, the decrease in cytochrome P-450 mRNA level in the *c-myc* overexpressing nodule could be indirectly linked to the increased proliferation rate of the underlying cell population. An even more dramatic increase in



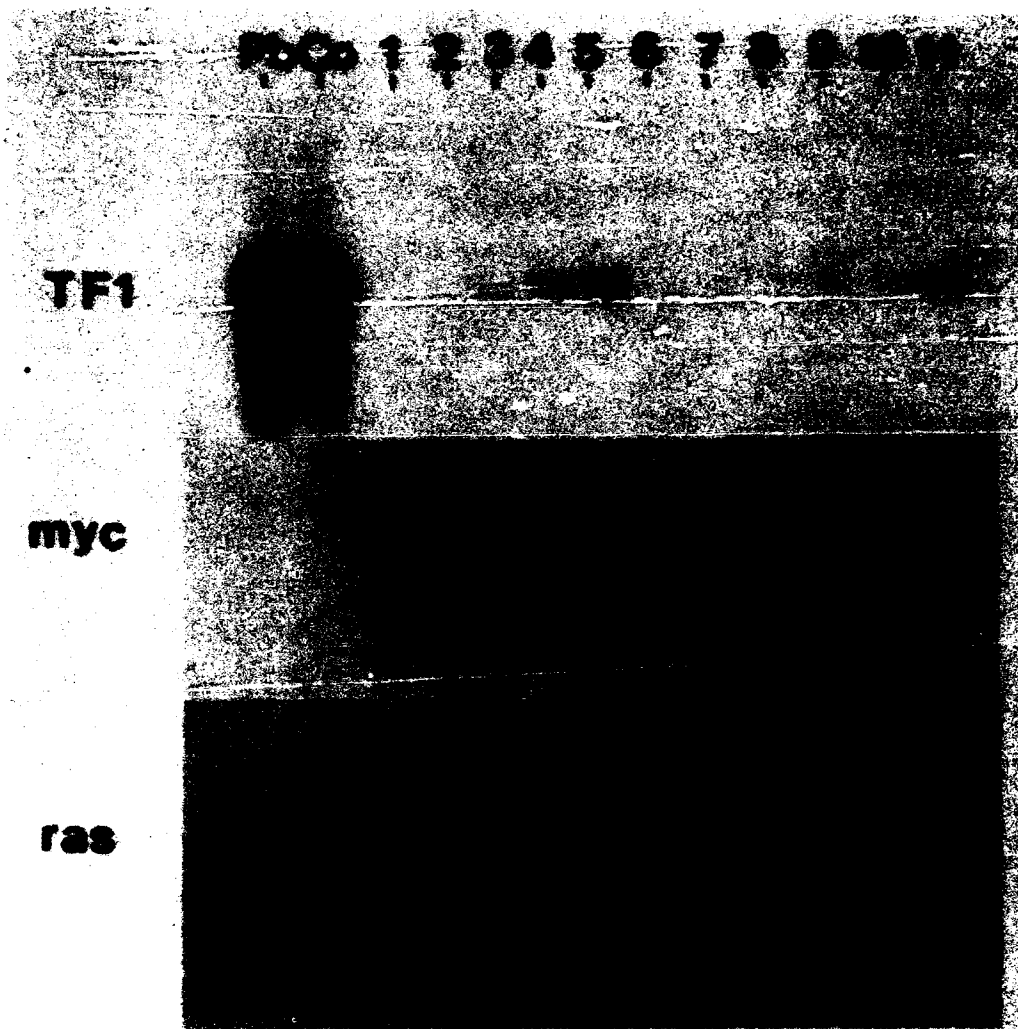


**Figure 10. Expression of Cytochrome P-450 and *c-myc* Specific mRNAs in Rat Hepatic Nodules as Compared to Normal Liver Tissue.** Total cellular RNA was isolated from hepatic nodules, separated on 1.2% agarose gels, transferred to membranes, and hybridized to <sup>32</sup>P-labeled cDNA probes. Lane 1: RNA obtained from liver of an untreated rat. Lane 2: RNA from liver of a rat treated with PB solely. Lanes 3 to 5: RNA from three liver nodules from three rats treated with DEN (100 ppm in drinking water for 10 days) followed by exposure to PB (0.05% in diet); the PB-containing diet was withdrawn 10 days before killing. Lanes 6 to 8: RNA from three liver nodules from three DEN/PB-treated rats. PB treatment was until death. R17: Probe specific for PB-inducible cytochrome P-450 mRNA. TF1: Probe specific for constitutively expressed cytochrome P-450 mRNA. *C-myc*: Probe detecting *c-myc* protooncogene mRNA.

*c-myc* expression was detected in hepatocellular carcinoma induced in rats by continuous treatment with either DEN or NDEOL (Figure 11). Hybridization of the same RNA samples with the TF1 probe (specific for constitutive cytochrome P-450 isozyme) demonstrated a dramatic decrease in the underlying mRNA within almost all hepatocellular carcinoma investigated, probably again reflecting the highly elevated growth rate of these lesions. In contrast to *c-myc*, no significant increase in *Ha-ras* expression was seen in these same liver tumors (see Figure 11). These findings are in agreement with data from other laboratories [56], although somewhat differing results have been reported [57,58]. These differences might be explained at least in part by variations in the treatment protocols employed in these studies or by the use of different carcinogenicity endpoints.

Specific point mutations at codon 61 of the *Ha-ras* protooncogenes leading to activation of this gene have been reported to occur at a high frequency in spontaneous and carcinogen-induced liver tumors of the B6C3F<sub>1</sub> mouse [59,60]. Activating mutations at codon 12 of the *Ha-ras* gene have also been reported in *N*-nitroso-methylurea-induced mammary tumors of the rat [61], whereas no such mutations at either codon 12 or 61 have been found in carcinogen-induced liver tumors of the Fischer 344 (F-344) rat [62]. We were, therefore, interested to know whether or not similar mutations in the *Ha-ras* gene would also be present in DEN and NDEOL-induced liver tumors of the Wistar rat. Mutation analysis of codon 61 was performed by making use of a restriction-length polymorphism induced by an A->T transversion mutation at the second base of this codon, which can be detected by restriction of genomic DNA with Xba1 [40].

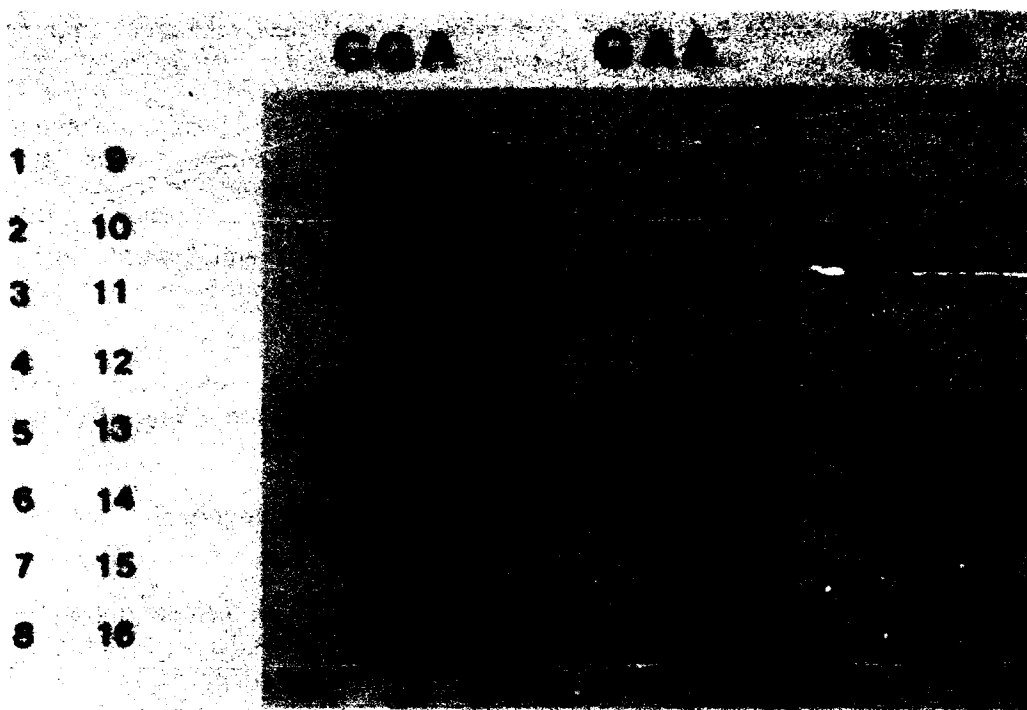
Using this restriction enzyme, two DNA fragments were detected with the *Ha-ras* specific BS9 clone on Southern blots. There was no difference in fragment lengths between DNA samples from rat liver tumors and normal rat liver tissue (Figure 12). Differences in signal intensities between the various samples are probably not indicative of amplification of the *Ha-ras* gene, but presumably reflect differences in DNA concentration on the filters, because similar overall intensity patterns were observed when rehybridizing the filters with the TF1 probe (see Figure 12). For mutation analysis at codon 12, the method of selective oligonucleotide hybridization was used following amplification of the interesting gene sequence by means of the polymerase chain reaction [41]. Using the oligonucleotide probe specific for the wild type sequence, we observed clear signals with all tissue samples whereas no signal was obtained with any of the oligonucleotides that would detect codon 12-mutated alleles of the *Ha-ras* gene. The results of this investigation are shown in an exemplified form in Figure 13. In summary, our investigation gave no hint of any mutation at either codon 12 or 61 of the *Ha-ras* protooncogenes in any of the 11 rat liver tumors used throughout this study. Because the *Ha-ras* gene was neither overexpressed nor activated by point mutation in rat liver tumors, these results suggest that this protooncogene may be of minor importance for carcinogenesis in liver of this animal species. In contrast to the rat, the B6C3F<sub>1</sub> mouse is characterized by a relatively high background incidence of spontaneous liver tumors and is highly susceptible to chemical carcinogens and tumor promoters [63]. Therefore, it seems conceivable that the increased sensitivity of this and certain other mouse strains to develop liver neoplasias might be correlated with a high mutability in the *Ha-ras* protooncogene and/or preferential selection and clonal expression of *Ha-ras*-mutated liver cells [64]. We are presently studying this question in more detail.



**Figure 11. Expression of Cytochrome P-450, *c-myc*, and *Ha-ras* mRNA in Carcinogen-Induced Rat Hepatocellular Carcinoma.** Total cellular RNA was isolated and separated on agarose gels. Following filter transfer the samples were hybridized to <sup>32</sup>P-labeled cDNA probes specific for the various genes. Lane Pb: RNA from liver of a PB-treated rat. Lane Co: RNA from liver of an untreated rat. Lanes 1 to 11: RNA from hepatocellular carcinomas induced in rat liver by treatment of the animals with either DEN (5 mg/kg body weight for 10 days) followed by continuous exposure to NDEOL (2000 ppm in drinking water) or NDEOL administration alone. TF1: Probe specific for constitutively expressed cytochrome P-450 mRNA. *Myc*: Probe detecting *c-myc* protooncogene mRNA. *Ras*: Probe detecting *Ha-ras* protooncogene mRNA.



**Figure 12. Xba1 Restriction Pattern of DNA from Rat Liver Tumors and Control Tissue following Hybridization with Ha-ras and Cytochrome P-450 Specific Probes.** Genomic DNA was isolated from the various tissues. Following filter transfer, DNA samples (10  $\mu\text{g}/\text{lane}$ ) were hybridized with the  $^{32}\text{P}$ -labeled cDNA probes. Lanes Co: DNA from control liver tissue. Lane 1 to 11: DNA from hepatocellular carcinoma (for treatment of animals see legend to Figure 11). Ras: Ha-ras specific cDNA probe. TF1: Probe detecting cytochrome P-450 specific sequences.



**Figure 13. Analysis of Point Mutations at Codon 12 of the Ha-*ras* Protooncogene in Rat Liver Tumor Cells.** Genomic DNA was isolated from control liver and hepatocellular carcinomas. A 138 base pair fragment around codon 12 of the Ha-*ras* gene was selectively amplified by use of the polymerase chain reaction. The amplified samples were dot-blotted onto filter membrane and hybridized to <sup>32</sup>P-labeled oligonucleotide probes detecting specifically the codon 12 wild-type sequence GGA or the point-mutated sequences GAA and GTA, respectively. Dots 1 and 3: DNA from control liver. Dots 4 to 14: DNA from rat hepatocellular carcinomas (for treatment of rats see legend to Figure 11). DNA samples from mouse skin tumors with known mutations at codon 12 also were blotted onto the filter membrane serving as positive controls for the GAA (dot 15) and the GTA (dot 16) sequence.

#### ACKNOWLEDGMENTS

We thank Dr. C.R. Wolf and Dr. F. Oesch for gifts of antibodies. Dr. A. Balmain is greatly acknowledged for helpful advice in mutation analysis and gift of DNA primers and oligonucleotides. We also thank R. Schmitt and J. Mahr for excellent technical assistance.

#### REFERENCES

- 1 Knudson, A.G. (1985) Hereditary cancer, oncogenes, and anti-oncogenes. *Cancer Res.* 45, 1437-1443.
- 2 Moolgavkar, S.H. and Knudson, A.G., Jr. (1981) Mutation and cancer: A model for human carcinogenesis. *J. Natl. Cancer Inst.* 66, 1037-1052.
- 3 Moolgavkar, S.H. (1983) Model of human carcinogenesis: action of environmental agents. *Environ. Health Perspect.* 50, 285-291.

- 4 Emmelot, P. and Scherer, E. (1980) The first relevant cell stage in rat liver carcinogenesis: a quantitative approach. *Biochem. Biophys. Acta.* 605, 247-304.
- 5 Gössner, W. and Friedrich-Freska, H. (1964) Histochemische Untersuchungen über die Glucose-6-phosphatase in der Rattenleber während der Kanzerisierung durch Nitrosamine. *Z. Naturforsch.* 19b, 862.
- 6 Friedrich-Freksa, H., Gössner, W. and Börner, P. (1969a) Histochemische Untersuchungen der Cancerogenese in der Rattenleber nach Dauergabe von Diäthylnitrosamin. *Z. Krebsforsch.* 72, 226-239.
- 7 Friedrich-Freksa, H., Papadopulu, G. and Gössner, W. (1969b) Histochemische Untersuchungen der Cancerogenese in der Rattenleber nach zeitlich begrenzter Verabfolgung von Diäthylnitrosamin. *Z. Krebsforsch.* 72, 240-253.
- 8 Bannasch, P. (1968) The cytoplasm of hepatocytes during carcinogenesis. *Recent Results Cancer Research* 19, Springer, Berlin, Heidelberg, New York.
- 9 Bannasch P., Hacker, H.J., Klimek, F. and Mayer, D. (1984) Hepatocellular glycogenesis and related pattern of enzymatic changes during hapatocarcinogenesis. In: G. Weber (Ed.), *Advances in Enzyme Regulation*, Vol. 22, Pergamon Press, Oxford, pp. 97-121.
- 10 Scherer, E. and Emmelot, P. (1976) Kinetics of induction and growth of enzyme-deficient islands involved in hepatocarcinogenesis. *Cancer Res.* 36, 2544-2554.
- 11 Pugh, T.D. and Goldfarb, S. (1978) Quantitative histochemical and autoradiographic studies of hepatocarcinogenesis in rats fed 2-acetylaminofluorene followed by phenobarbital. *Cancer Res.* 38, 4450-4457.
- 12 Farber E. (1980) The sequential analysis of liver cancer induction. *Biochem. Biophys. Acta.* 605, 149-166.
- 13 Pitot, H.C., Barsness, L. Goldsworthy, T. and Kitagawa, T. (1978) Biochemical characterization of stages of hepatocarcinogenesis after single dose of diethylnitrosamine. *Nature* 271, 456-458.
- 14 Pitot, H.C. and Sirica, A.E. (1980) The stages of initiation and promotion in hepatocarcinogenesis. *Biochem. Biophys. Acta* 605, 191-215.
- 15 Buchmann, A., Kuhlmann, W., Schwarz, M., Kunz, W., Wolf, C.R., Moll, E., Friedberg, T. and Oesch, F. (1985) Regulation and expression of four cytochrome P-450-isoenzymes, NADPH-cytochrome P-450 reductase, the glutathione transferases B and C and microsomal epoxide in preneoplastic and neoplastic lesions in rat liver. *Carcinogenesis* 6, 513-521.
- 16 Buchmann, A., Schwarz, M., Schmitt, R., Wolf, C.R., Oesch, F. and Kunz, W. (1987) Development of cytochrome P-450 altered preneoplastic and neoplastic lesions during nitrosamine-induced hepatocarcinogenesis in the rat. *Cancer Res.* 47, 2911-2918.
- 17 Kunz, W., Appel, K.E., Rickart, R., Schwarz, M., Stöckle, G. (1978) Enhancement and inhibition of carcinogenic effectiveness of nitrosamines. In: H. Remmer, H.M. Bolt, P. Bannasch, and H. Popper (Eds.), *Primary Liver Tumors*, MTP Press, Lancaster, UK, pp. 261-283.

- 18 Kunz, H.W., Buchmann, A., Schwarz, M., Schmitt, R., Kuhlmann, W.D., Wolf, C.R. and Oesch, F. (1987) Expression and inducibility of drug metabolizing enzymes in preneoplastic and neoplastic lesions of rat liver during nitrosamine-induced hepatocarcinogenesis. *Arch. Toxicol.* 60, 198-203.
- 19 Peraino, C., Staffeldt, E.F., Carnes, B.A., Ludemann, V.A., Blomquist, J.A. and Vesselinovitch, S.D. (1984) Characterization of histochemically detectable altered hepatocyte foci and their relationship to hepatic tumorigenesis in rats treated once with diethylnitrosamine or benzo[a]pyrene one day after birth. *Cancer Res.* 44, 3340-3347.
- 20 Vesselinovitch, S.D., Hacker, J.J. and Bannasch, P. (1985) Histochemical characterization of focal hepatic lesions induced by single diethylnitrosamine treatment in infant mice. *Cancer Res.* 45, 2774-2780.
- 21 Rabes, H.M., Bücher, T., Hartmann, A., Linke, I. and Dünwald, M. (1982) Clonal growth of carcinogen-induced enzyme deficient preneoplastic cell population in mouse liver. *Cancer Res.* 42, 3220-3227.
- 22 Williams, E.D., Wareham, K.A. and Wowell, S. (1983) Direct evidence for the single cell origin of mouse liver cell tumors. *Br. J. Cancer* 47, 723-726.
- 23 Rabes, H.M., Kerber, R. and Wilhelm, R. (1983) Development and growth of early preneoplastic lesions induced in the liver by chemical carcinogens. *J. Cancer Res. Clin. Oncol.* 106, 85-92.
- 24 Goldfarb, S. and Pugh, T.D. (1981) Enzyme histochemical phenotypes in primary hepatocellular carcinomas. *Cancer Res.* 41, 2092-2095.
- 25 Kunz, H.W., Tennekes, H.A., Port, R.E., Schwarz, M., Lorke, D. and Schaudé, G. (1983) Quantitative aspects of chemical carcinogenesis and tumor promotion in liver. *Environ. Health Perspect.* 50, 113-122.
- 26 Kunz, H.W., Schwarz, M., Tennekes, H., Port, R. and Appel, K.E. (1985) Mechanism and dose-time response characteristics of carcinogenic and tumor promoting xenobiotics in liver. In: K.E. Appel and A.G. Hildebrandt (Eds.), *Tumorpromotoren, Erkennung, Wirkungsmechanismen und Bedeutung*. BGA - Schriften 6: MMV Medizin Verlag München, 76-94.
- 27 Vesselinovitch, S.D. and Mihailovitch, N. (1983) Kinetics of diethylnitrosamine hepatocarcinogenesis in the infant mouse. *Cancer Res.* 43, 4253-4259.
- 28 Hacker, N.J., Moore, M.A., Mayer, D. and Bannasch, P. (1982) Correlative histochemistry of some enzymes of carbohydrate metabolism in preneoplastic and neoplastic lesions in the rat liver. *Carcinogenesis* 6, 513-521.
- 29 Estadella, M.D., Pujol, M.J. and Domingo, J. (1984) Enzyme pattern and growth rate of liver preneoplastic clones during carcinogenesis by diethylnitrosamine. *Oncology* 41, 276-279.
- 30 Wachstein, M. and Meisel, E. (1957) Histochemistry of hepatic phosphatases at physiologic pH. *Am. J. Clin. Pathol.* 27, 13-23.
- 31 Lojda, J., Gossrau, R. and Schiebler, T.H. (1976) *Enzymhistochemische Methoden*. Springer Verlag, Heidelberg, p.p. 182-184.

- 32 Hotchkis, R.D. (1948) A microsomal reaction resulting in the staining of polysaccharide structures in fixed tissue preparation. *Arch. Biochem.* 16, 131-141.
- 33 Wolf, C.R. (1986) Cytochrome P-450s: polymorphic multigene families involved in carcinogen activation. *TIG* 209-214.
- 34 Schwarz, M., Peres, G., Beer, D.G., Maor, M., Buchmann, A., Kunz, W. and Pitot, H.C. (1986) Expression of albumin messenger RNA detected by *in situ* hybridization in preneoplastic and neoplastic lesions in rat liver. *Cancer Res.* 46, 5903-5912.
- 35 Kumar, A., Raphael, C. and Ardesnik, M. (1983) Cloned cytochrome P-450 cDNA. Nucleotide sequence and homology to multiple phenobarbital induced mRNA species. *J. Biol. Chem.* 258, 11280-11284.
- 36 Friedberg, T., Waxman, D.J., Atchison, M., Kumar, A., Haaparanta, T., Raphael, C. and Ardesnik, M. (1986) Isolation and characterisation of cDNA clones for cytochromes P-450 immunochemically related to rat hepatic P-450 form PB1. *Biochemistry* 25, 7975-7983.
- 37 Ellis, R.W., DeFeo, D., Maryak, J.M., Young, H.A., Shih, T.Y., Chang, E.H., Lowy, D.R. and Scolnik, E.M. (1980) Dual evolutionary origin for the rat genetic sequences of Harvey murine sarcoma virus. *J. Virol.* 36, 408-420.
- 38 Shen-Ong, G.L.C., Keath, E.J., Piccoli, S.P. and Cole, M.D. (1982) Novel *myc* oncogene RNA from abortive immunoglobulin-gene recombination in mouse plasmacytomas. *Cell* 31, 443-452.
- 39 Maniatis, T., Fritsch, E.F. and Sambrook, J. (1982) *Molecular Cloning, A Laboratory Manual.* Cold Spring Harbor Laboratory, Cold Spring Harbor, NY.
- 40 Quintanilla, M., Brown, K., Ramsden, M. and Balmain, A. (1986) Carcinogen-specific mutation and amplification of *Ha-ras* during mouse skin carcinogenesis. *Nature* 322, 78-80.
- 41 Saiki, R.K., Gelfand, D.H., Stoffel, S., Scharf, S.J., Higuchi, R., Horn, G.T., Mullis, K.B. and Ehrlich, H.A. (1988) Primer-directed enzymatic amplification of DNA with a thermostable DNA polymerase. *Science*, 239: 487-491.
- 42 Verlaan-de Vries, M., Bogaard, M.E., Van Den Elst, J.H., Van Boom, H., Van Der Eb, A.J. and Bos, J.L. (1986) A dot-blot screening procedure for mutated *ras* oncogenes using synthetic oligodeoxynucleotides. *Gene* 50, 313-320.
- 43 Campbell, H.A., Yuan-Ding, Xu, Hanigan, M.H. and Pitot, H.C. (1986) Application of quantitative sterology to the evaluation of phenotypically heterogenous enzyme-altered foci in the rat liver. *J. Natl. Cancer Inst.* 76, 751-767.
- 44 Campbell, H.A., Pitot, H.C., Potter, V.R. and Laishes, B.A. (1982) Application of quantitative sterology to the evaluation of enzyme-altered foci in rat liver. *Cancer Res.* 42, 465-472.
- 45 Druckrey, H. (1967) Quantitative aspects in chemical carcinogenesis. *U.I.C.C. Monographs.* 7, 60-78.
- 46 Preussmann, R., Habs, M., Habs, H. and Schmähl, D. (1982) Carcinogenicity of *N*-nitrosodiethanolamine in rats at five different dose levels. *Cancer Res.* 42, 5167-5171.



- 47 Zerban, H., Preussmann, R. and Bannasch, P. (1988) Dose-time relationship of the development of preneoplastic liver lesions induced in rats with low doses of *N*-nitrosodiethanolamine. *Carcinogenesis* 9, 607-610.
- 48 Schwarz, M., Pearson, D., Port, R. and Kunz, W. (1984) Promoting effect of 4-dimethyl aminoazo-benzene on enzyme altered foci induced in rat liver by *N*-nitrosodiethanolamine. *Carcinogenesis* 5, 725-730.
- 49 Schwarz, M., D. Pearson, A. Buchmann, and W. Kunz. (In Press) The use of enzyme-altered foci for risk assessment of hepatocarcinogens. NATO ASI Series, Plenum Publishing Corporation, New York.
- 50 Schulte-Hermann, R., Roome, N., Timmermann-Troisiener, J. and Schuppler, J. (1984) Immunocytochemical demonstration of a phenobarbital-inducible cytochrome P-450 in putative preneoplastic foci of rat liver. *Carcinogenesis* 5, 143-153.
- 51 Waxman, D.J. and Walsh, C. (1982) Phenobarbital induced rat liver cytochrome P-450. *J. Biol. Chem.* 257, 10446-10457.
- 52 Schwarz, M., Peres, G., Buchmann, A., Friedberg, T., Waxman, D.J. and Kunz, W. (1987) Phenobarbital induction of cytochrome P-450 in normal and preneoplastic rat liver: comparison of enzyme and mRNA expression as detected by immunohistochemistry and *in situ* hybridization. *Carcinogenesis* 8, 1355-1357.
- 53 Fausto, N. and Shank, P.R. (1983) Oncogene expression in liver regeneration and hepatocarcinogenesis. *Hepatology* 3, 1016-1023.
- 54 Makino, R., Hayashi, K. and Sugimura, T. (1984) *C-myc* transcript is induced in rat liver at a very early stage of regeneration or by cycloheximide treatment. *Nature* 310, 697-698.
- 55 Beer, D.G., Schwarz, M., Sawada, N. and Pitot, H.C. (1986) Expression of *H-ras* and *c-myc* protooncogenes in isolated  $\gamma$ -glutamyl transpeptidase-positive rat hepatocytes and in hepatocellular carcinomas induced by diethylnitrosamine. *Cancer Res.* 46, 2435-2441.
- 56 Hsieh, L.L., Hsiao, W. L., Peraino, C., Maronpot, R.R. and Weinstein, I.B. (1987) Expression of retroviral sequences and oncogenes in rat liver tumors induced with diethylnitrosamine. *Cancer Res.* 47, 3421-3424.
- 57 Corcos, D., Defer, N., Raymondjean, M., Paris, B., Corral, M., Tichonicky, L. and Kruh, J. (1984) Correlated increase of the expression of the *c-ras* gene in chemically induced hepatocarcinomas. *Biochem. Biophys. Res. Commun.* 122, 259-264.
- 58 Makino, R., Hayashi, K., Sato, S. and Sugimura, T. (1984) Expression of the *c-Ha-ras* and *c-myc* genes in rat liver tumors. *Biochem. Biophys. Res. Commun.* 119, 1096-1102.
- 59 Reynolds, S.J.H., Stowers, S.J., Patterson, R.M., Maronpot, R.R., Aaronson, S.A. and Anderson, M.W. (1987) Activated oncogenes in B6C3F<sub>1</sub> mouse liver tumors: implications for risk assessment. *Science* 237, 1309-1316.
- 60 Wiseman, R.W., Stowers, S.J., Miller, E., Anderson, M.W. and Miller, J.A. (1986) Activating mutations of the *c-Ha-ras* protooncogene in chemically induced hepatomas of the male B6C3F<sub>1</sub> mouse. *Proc. Natl. Acad. Sci. USA*, 83, 5825-5829.

- 61 Zarbl, H., Sukumar, S., Arthur, A.V., Martin-Zanca, D. and Barbacid, M. (1985) Direct mutagenesis of Ha-ras-1 oncogenes by *N*-nitroso-*N*-methylurea during initiation of mammary carcinogenesis in rats. *Nature*, 315-385.
- 62 Stowers, S.J., Wiseman, R.W., Ward, J.M., Miller, E.C., Miller, J.A., Anderson, M.W. and Eva, A. (1988) Detection of activated protooncogenes in *N*-nitrosodiethylamine-induced liver tumors: A comparison between B6C3F<sub>1</sub> mice and Fischer 344 rats. *Carcinogenesis* 9, 271-276.
- 63 Drinkwater, N.R. and Ginsler, J.J. (1987) Genetic control of hepatocarcinogenesis in C57BL/6J and C3H/HeJ inbred mice. *Carcinogenesis* 7, 1701-1707.
- 64 Buchmann, A., Bauer-Hofmann, R. Schwarz, M. and Balmain, A. (In Press) Detection of mutations in the H-ras protoongene in liver tumours of the CF1 mouse. NATO ASI Series, Plenum Publishing Corporation, New York.

**RELATIONSHIP BETWEEN CELL REPLICATION AND CARCINOGENICITY OF NONGENOTOXIC AGENTS**

Dr. Thomas Goldsworthy

**CIIT, P.O. Box 12137, Research Triangle Park, NC 27709**

*Manuscript not submitted*

### SESSION III

#### PANEL DISCUSSION

**Dr Ron Wolff (Lilly Laboratory):** I was wondering if you had any idea at this point what kind of protein products that the HES gene was controlling that would be giving rise to the effects that you have described?

**Drinkwater:** I wish we knew the answer to that. The thing that we have concentrated on most recently is trying to map this gene. To date I could summarize the data by saying the gene is not anywhere that we have looked, and we have looked at a fair number of places. So, we are taking a somewhat more consistent approach to identifying the application. Having done that, the idea is to then attempt to molecularly isolate the gene and hope that knowing the sequence of that gene will tell us something about its function. At the protein level, we have absolutely no information at the present time.

**Dr Ray Yang (NIEHS):** Dr Trosko, thanks very much for a very stimulating talk. I have two questions. One is when you talk about environmental agents interfering with cell communication, it seems to me by that very fact we are talking about a molecular event and, therefore, am I right to assume that for this sort of process you need only a very, very low concentration; specifically, in terms of carcinogenesis, perhaps we are talking about a similar level as with a DNA adduct, in terms of a few molecules and so on? That is one question. The second question: Is *in vitro* cell communication an adequate reflection of *in vivo* cell communication?

**Trosko:** Two beautiful questions and I didn't set you up for that. The answer to the first is no, conditionally. There are at least three families of promoters that I have been able to discern by looking at hundreds of chemicals that modulate gap junctions. One is what I call the TPA-TCDD type; they work at nanogram levels, hormone-like levels, because there are receptors for it. Secondly, there is the DDT-phenobarbital type that work at microgram levels to block cell-cell communication. Then finally, there is the NTA, the detergent-type and the saccharin-type, that work at milligram levels. Today if I was told that a chemical was a promoter in the animal, all I have to ask you is did you use pounds, ounces, or grams and I could tell you basically how they would work, just from my experience. However, I say it is conditional in the sense that we now have shown their synergisms, so you could in fact use a low level of DDT, which by itself on the cells does not down-regulate gap junction, because it mediates the calcium levels, and you could use TPA at a low level that does not regulate gap junctions. But you put the two together on the cells, and they synergize. Mainly because, it turns out, they happen to interfere with gap junction by the same pathway, protein kinase. The calcium affects the protein kinases and the TPA activates the protein kinases. Does the *in*

*vivo* study of gap junctions reflect what goes on *in vivo*? The answer is that in reality and in principle it does, but specifically it does not. There is no way it can. How do we get cells to grow in culture? We throw all kinds of gunk on the cells, fetal calf serum with everything you can imagine in it, and all kinds of media and what have you. These things affect the gap junctions. In fact, when we looked for gap junction in communication in normal human keratinocytes, we bought a commercial media with all the growth factors, and what have you, and we couldn't find any gap junction communication. Then it dawned on us that the reason why was because those cells were growing because we threw the growth factors on. When we put the cells in the same media without the growth factors they communicated beautifully, and then we added the growth factors back one by one and it blocked communication, and then the cells grew. What I am saying is when you put cells in culture, you want them to grow. In effect you are conditioning the situation to have fewer gap junctions than they normally will because you don't want cells not to grow, normally. Finally, I just want to add that if Jim Klaunig is in the audience, in answer to this major question, I could show, let's say, a chemical blocks gap junctions in certain cell types in culture, but the question is does it block it in you in any particular organ? We cannot predict at this date whether this is the case. We are going to have to go to the next stage developing an *in vitro*, *in vivo* model and Dr Klaunig at Ohio, using it from Glenn Sipes's Laboratory, now has a new tissue slice technique where you can microimpel dyes in the cells and the organ, watch communication, and then we can also watch what happens with those cells when they communicate or don't communicate in the tissue leaving the tumors. So we are going to the next stage, whether we can ultimately take any given chemical and monitor in you, like monitoring for adducts in your blood, whether gap junction communication is going on or not. Right now I cannot conceive of anything, any technique to do that but that is where we ultimately are going to have to go. I hope I have answered your question.

**Dr Henry Wall (NSI):** Dr Eustis, at the completion of the microscopic pathology examinations for toxicity study, what are the usual criteria applied to make a final interpretation that a hyperplastic or dysplastic lesion has preneoplastic significance?

**Eustis:** I think as far as hyperplasia is concerned, we always look for other evidence that the response we are getting is due to some sort of cell damage, so whatever tissue it is, we look for other evidence that there is actual cell necrosis or some other degenerate process that is occurring. If we see what we think is a hyperplastic lesion and we can't detect any evidence of primary cell damage for it, we may suspect that it might be a preneoplastic response. As far as dysplasia is concerned, I think any time you see true dysplasia you have to think in terms that it is a possible preneoplastic nature; I think you can never get a precise answer, it is just a guesstimation of what is happening. But you need to take into consideration all the evidence that you have that there might not be cell necrosis occurring and other things.

**Dr Clay Frederick (Rohm and Haas):** I have a question for Dr Eustis. I was very interested in your forestomach development and the tumors you were describing and I find that response to be fascinating. The forestomach does seem to be very sensitive to a variety of irritating compounds, dose gavage and otherwise. I think the most interesting example is propionic acid dose in the drinking water. This is forestomach tumors, and propionic acid is interesting because it is a normal constituent of the gut lumen and it is formed by the bacteria in the rat forestomach by fermentation, yet when dosed, the drinking water gives tumors. I guess I would be interested in your speculation or comments as to why you think the forestomach may be so sensitive to irritating compounds or disturbance in physiology

**Eustis:** I am not sure that it is more sensitive than other tissue. I certainly think that if you are given something by gavage or in a feed study you are naturally going to have the material deposited in the stomach where it is going to stay for a certain time period. Certainly if you are depositing by gavage, you are depositing a relatively large amount that is going to stay there for the time it takes to exit the stomach. Squamous epithelium does not have the mucous protection that the glandular epithelium might have. It may be a little simpler in nature metabolically, so I think there are just lots of things involved. I am not sure that the squamous epithelium of the stomach is any more sensitive than the skin, per se.

**Conolly:** I would like to ask Dr Goldsworthy a question. You touched on the distinction between mitotic stimulus to cell replication and cell replication that is presumably a function of possibly a regenerative hyperplasia cytotoxicity sort of event, and that they are thought not to be equivalent in terms of how they contribute to the carcinogenic process. Can you elaborate on that at all?

**Goldsworthy:** Yes, that is mainly from studies which demonstrated that when you give equal amount of cell turnover, but given by a mitogenic agent vs. cell regenerative agent it was not capable of helping induce the initiating stage nor the promoting stage. It just shows that perhaps there are different types of events that occur during cell rep, perhaps it is a gene expression that perhaps induces why a mitogenic agent may not work compared to a regenerative-type agent. We are now doing studies on this where we have identified mitogenic agents and regenerative agents and given them both in initiation-promotion regimens and looked at cell replication and other parameters that occur and see if they do induce lesions or whether they do not.

**Conolly:** What you are saying is that the likelihood of a significant mutation occurring during cell replication may be different in different cases, depending on the pattern of gene expression that is occurring during the process of cell replication?

**Goldsworthy:** That is right.

**Yang:** I have two questions. The first question I want to ask in the context of the National Toxicology Program. It is not just my program, or the staff members' of the National Toxicology Program, but everybody's in the United States I want to ask this in context to the whole panel, but I want to specifically say that Dr Eustis and I didn't set up this question; it is just spontaneous and if he wants to comment that it is fine. I think Dr Drinkwater illustrated in his three strains of mice that the B6C3F<sub>1</sub> is kind of medium sensitive in terms of carcinogenicity studies, and we at NTP had been struggling with the fact that there is a lot of disagreement in terms of the mouse tumor significance in terms of carcinogenicity, and thinking into the future, is there something the panel could offer in terms of a strain of mice that might be a good model to use? Specifically, in terms of a transgenic mice, whether or not there are good reasons that the NTP should adopt that sort of philosophy, change or modify our assay procedures. This is the first question.

**Drinkwater:** As far as the transgenic mice go, I know that there has been a suggestion following Leder's work, using *mic* transgenic and *ras* transgenic mice that those animals may provide a good test animal for studying tumor induction. I am not entirely convinced of that.

**Yang:** In the sense of what, more sensitive?

**Drinkwater:** That is the argument that has been made, at least that is the argument that has been made in the context of using those animals. I am not entirely convinced of that argument, however, given that although it is clear that an additional event is required in the cells of those transgenic animals that results in the eventual development of the tumors, it is not in all cases clear what that event might be. And in certain transgenic models that would have been as likely to be the expression of the transgene that may not correspond to what is going on in *in vivo* carcinogenesis. So it not clear to me that the transgenic provide a particularly good approach. As far as whether any given inbred mouse strain or F<sub>1</sub> hybrid is better than any other, at nearly any site one cares to look one can find inbred mouse strains that are highly susceptible to tumor induction as well as those strains that are highly resistant. My off-hand feeling is that the B6C3F<sub>1</sub> hybrid is probably as good as any and that the high sensitivity of that strain is in its favor from the point of view that you are, in some sense, using it as an amplifier of carcinogenic response; that is, it is very sensitive for initiating agents and it is likely also to be sensitive for nongenotoxic promoting agents. The interpretation of those results is open to some question in the latter case because nongenotoxic agents, agents that act as promoters, do so in many instances in both tissue-specific and species-specific fashions, so that you always have the problem of extrapolation from that point.

**Yang:** Let me go on to the second question then, specifically for Dr Goldsworthy. This alpha 2- $\mu$  globulin, can you tell me what perhaps is the evolutionary significance of this particular protein?

What is the function? Is it a mistake by Mother Nature? Why is it in male rats and what is it doing in the kidney?

**Goldsworthy:** Most of my work was done in the *in vivo* study and, as I mentioned, Jim Swenberg is continuing that work. It is a specific male rat protein as you said and therefore we are concerned indeed whether humans exposed to such compounds, which is a growing list, would elicit the same tumor response. Obviously, if you don't have the alpha 2- $\mu$ , you probably don't get the same cell replication effects that we think are important, so it is a very big question. They are doing a continuing amount of studies. The main activity or function for alpha 2- $\mu$  is not yet known. Humans do not have the alpha 2- $\mu$  but they have a similar size class of proteins, obviously, so they are doing studies of binding, and looking at super family structure of proteins, and structure relationships of proteins in trying to elucidate that answer, and at this point they really can't answer that question.

**Yang:** In my naive impression, the evolutionary process goes very slowly, it is highly efficient, and everything has got a purpose. It seems to me that it is highly unlikely that the evolution process is such that this protein is created to wait for gasoline to be used. . .

**Goldsworthy:** It is known in the sexual maturity of male rats. So that is why it is in the males and not the females. That part is known. What creates impartiality to digestion in the kidney and the function going on there is not known, but it is known to help in the maturation of male rats, the sexual maturity, so it does have a function.

**Loring Pitts (Envirosphere Norcross, GA):** I did some work initially when I was at Wright-Patterson with the hydrocarbons and this thing. At that time we were not calling it a tumor. I have been out of the field for a little bit. Part of the question is has there been any other species besides the male rat that has exhibited what you are talking about? It is my impression in remembering that there has not been, but have you looked at any other species and found a similar kind of effect?

**Goldsworthy:** We have only looked at rats and mice, and the males and females. Other laboratories have only done the same, the response was the same. They have also looked at other species, guinea pigs and rabbits even, and it has not been shown except in the male rat.

**Drinkwater:** It might be pointed out that the mouse has a quite similar family of proteins that are also antigen-regulated and highly secreted in male mice, but you don't see the nephropathy in the case of mice.

**Frederick:** I would like to play off of Ray Yang's question. Within male rats, focus the question a little more on the localization of this; have we just looked in the F-344 or have we looked at a lot of strains? I honestly do not know, I have not noticed it in the literature, but it is at least possible that



this particular strain may have an artifact in the degradation of this particular material that may make it more simple; I have no idea.

**Drinkwater:** I do know that the Sprague Dawley rat also will show a similar kind of effect, at least in terms of morphological characteristics, in which you look at the kidneys after dosing with hydrocarbons and you will see the same protein drop as in the Sprague Dawley also.

**Goldsworthy:** Yes, they did a study, I think, with five different strains. They did see a similar response in several of the strains, but the magnitude of the response was altered in some of the strains.

**Dr Robert D'Amato (Procter and Gamble):** We have looked also at about five different strains of rat. Interestingly enough, there is a strain of rat that has a very low production of alpha 2- $\mu$  globulin in the murine and we have this hooded-type rat, and we have looked at that particular rat with several agents that exacerbate the binding to alpha 2- $\mu$ , and in that particular rat there is obviously very little binding; you do not get the accumulation of alpha 2- $\mu$  that you get with the other strains of rats; you do not get hyaline droplet; and more importantly, you do not get the renal nephrosis, which is the prime marker for the eventual tumorigenesis.

**Goldsworthy:** Have you done tumor studies with that rat as well?

**D'Amato:** No, we have not.

## LUNCHEON SPEECH

**MR. GARY D. VEST  
DEPUTY ASSISTANT SECRETARY OF THE AIR FORCE FOR  
ENVIRONMENTAL, SAFETY AND OCCUPATIONAL HEALTH  
Washington, DC**

Thank you. It is a distinct pleasure to be here today to discuss what I believe to be one of the most important issues facing occupational health and military readiness professionals. I hope that by the end of my remarks you will appreciate and understand the importance I place on toxicology as a critical element in executing our national defense and public health responsibilities. In the next few minutes I want to share some of my views on toxicology and how it relates to the Air Force mission.

The Air Force has been, is, and will continue to be a major user of hazardous materials and a generator of hazardous wastes. Although the methods we used in prior years to handle and dispose of hazardous wastes and, in some cases, to remediate damage to the environment, were proper, the challenges we face today to accomplish our mission and deal with hazardous materials in the workplace and in the environment are much more demanding and are taxing our professionals to the limit.

With the passage of legislation like the Toxic Substances Control Act, the Resource Conservation and Recovery Act, and CERCLA (Comprehensive Environmental Response Compensation and Liability Act), our elected officials sent a strong message to the regulated community – that we as a society must protect the health of the population in general and workers in the workplace in particular, as well as the overall environment, by controlling and minimizing the use of chemicals, many of which are absolutely essential to life in a modern world.

This is by no means an easy task for the Air Force because our installations already use over a thousand types of chemicals to support existing weapons systems and the normal functions of the air base community. Further complicating our ability to comply with Congressional mandates will be the challenges to reduce wastes that we will generate from emerging and future weapons systems that will be built using new technologies involving composites, new coatings, and supporting maintenance chemicals. We need to ensure that the path we take to protect our people and the public and to reduce our liability actively combines our technical, scientific, and operational resources to achieve hazardous waste minimization.

Nearly six years ago when I was appointed to my position, I knew little about toxicology or its real importance. Over the past few years I have come to the realization that we have not yet made the necessary commitment to really understanding the effects of chemicals and building and

manufacturing materials, and the processes involved with them. I say this not just in terms of the Department of the Air Force, the Department of Defense, the Federal Government, or American industry, but in terms of modern world society.

As you know better than most people, the modern world and its technology have brought mixed blessings. We have things that make life so much better and easier and secure; but in order to have those things we also have upped the stakes in terms of potential adverse impacts to workers in the workplace, to select groups of citizens, and to the human environment in general.

I suspect that the fundamental issue about toxicology is really one of philosophy, social contract, ethics, and morality. Simply stated, we need to step up to our societal obligations as professionals and government officials to understand and deal with the effects of the chemicals, materials, and processes that our agencies and industries bring into the workplace and the environment. In this country, every worker and citizen should be able to handle and use that which Government or industry provides with the confidence that, to the best of our ability, it is safe and not hazardous to health. The "Buyer Beware" philosophy is not acceptable for our people or the public when it comes to defense-generated chemicals, materials, or processes.

The Air Force and, for that matter, the entire aerospace industry, has a significant problem with identifying, characterizing, and understanding the potential health and environmental effects of new chemicals, combinations of chemicals, and the industrial and manufacturing processes associated with them. The development of advanced weapons systems and new aerospace technologies will be accompanied by new fuels, hybrid structural materials, and other unique chemicals as well as new processes, many of which have the potential for creating unacceptable health hazards for our personnel and, in some cases, for the public at large. This continuous influx of new and exotic materials from the research, development, and acquisition pipeline brings attention to the first point in the process at which decisions need to be made to procure or not procure a specific hazardous material.

Several years ago, I asked the Air Force Scientific Advisory Board to investigate the selection and use of hazardous materials in the weapons systems development and acquisition process. The major findings were as follows.

- The weapons systems acquisition process does not identify and include the goals of minimizing the use of hazardous and toxic materials nor does it address the long-term implications of management of hazardous wastes.
- The systems program offices or SPOs are the key point for consideration of environment, safety, and health factors. However, only safety currently is being adequately addressed. Identification of hazardous and toxic materials issues during the course of the weapons systems acquisition process will require early

involvement of environmental and health personnel who are currently not formally integrated into the process.

- There is no mechanism for a formal review by environmental, safety, and health personnel.

The study noted that life cycle impacts of hazardous material need to be identified early if we are to make real progress toward waste reduction.

Earlier this year, a general officer steering group, chaired by Major General Fredric Doppelt, the Commander of the Air Force Systems Command, Human Systems Division, was formed to investigate the long-term implications of implementing the findings of the Scientific Advisory Board (SAB) study. Paramount in their charter is one objective and that is to place specialists – health and environmental professionals – directly into the process so that new chemicals can be evaluated prior to system acceptance. Success is imperative because without accomplishing this basic objective we have little hope of really reducing the waste stream in a long-term, meaningful way and, perhaps more importantly, we will have limited potential to do the advance toxicology-related work early enough to make a real difference to the worker in the workplace.

If this bridge is built effectively between the weapons system research, development, and acquisition community and that of our toxicological capability, we should begin to better understand the exposures we will face from new materials and chemicals. This will do more than just add health and environmental professional resources to an already time and schedule-minded SPO, it will give the R, A, & D community an advocate on the SPO team who can fight for more environmentally acceptable and less toxic materials to support new systems. Our challenge is to work this early enough and successfully enough to find acceptable substitutes or do the necessary evaluation and analysis to understand health effects, and develop the method and controls to deal with them, but at the same time, not endanger the weapons system requirement or schedule.

We face a rough road ahead even if the changes to the acquisition process are successful. The Air Staff has modified AFR 800-2, the Acquisition Process, to require hazardous material review for possible substitution with less hazardous or toxic materials. It also includes a mandate to reduce the volume of materials to support new weapons systems. Other changes to supply and procurement regulations establish the requirement for tracking and control of materials to minimize occupational exposures. The Office of the Assistant Secretary of Defense (Production and Logistics) is working with the Defense Acquisition Board as a result of our initiative to institutionalize material selection by health and environmental personnel in all weapons systems programs. This is a major step forward.

In spite of all of our initiatives in the environmental and acquisition areas to reduce our wastes and future liabilities, we must ask if we are adequately focusing our attention on the area where you, the toxicology community, can help us the most. I believe the answer is no. In my opinion one of the

most pressing needs that we have today is to reduce the toxicity of chemicals in use or proposed for use through chemical substitution. Our present Technical Order and Military Specifications systems do little to allow our personnel in the field any flexibility to substitute less toxic or more environmentally acceptable materials when the situation arises. The problem is partly bureaucratic in nature, but we really must tackle it head on. All too often we face performance specifications where the health aspects vary based on different additives. For the most part, chemical toxicology is not a factor in material selection or use.

Our need to begin substituting less toxic materials in our supply system needs attention, but how do we take credit for it when we do it? I believe that our greatest contribution toward waste reduction will come after we devise a mechanism to account for it as a waste reduction statistic. There is no present method for equating toxicity reduction with chemical substitution, reuse, or recycling as a volumetric reduction. In many cases, nontoxic materials will be successfully substituted. However, many currently used chemicals will simply be substituted with less toxic ones. This is still a necessary action and critical if we are to reduce our occupational exposures.

I believe that we need far more toxicological data for the weapons systems research and development work that we have underway. The Air Force, not unlike its private sector counterparts, has its own unique chemicals which often do not have as much toxicology data as we would like to support exposure assessments. We need to look beyond traditional risk assessment to determine the mechanism by which the chemical acts in the body. This will provide decision-makers with a better understanding of the chemical and its associated risks before it is employed in a weapons system. Just as private industry must identify their new products as toxic under TSCA, we need to strive for better, more conclusive data on our own chemicals.

Recently there has been a fair amount of public controversy about the potential adverse health effects of the use of composite materials in the aerospace industry. In particular, the Air Force has been the target of interest. I have looked carefully at this aspect of occupational health, industrial hygiene, and toxicology and have reached the following conclusions.

- There are things that we do not know about the health effects of composites and the chemicals and manufacturing/maintenance processes associated with them.
- We need to carefully evaluate the need for epidemiological studies of workers involved with composite technology.
- We need to know if the exposure standards for individual materials and combinations of materials are adequate.
- We need to determine what knowledge and data gaps exist with reference to the synergistic effects of chemical combinations associated with composite technology.

- We need to evaluate the manufacturing and maintenance processes associated with composites technology and determine if they are optimum in terms of worker safety and health.
- We need to evaluate engineering controls and worker-protective equipment associated with composites technology and determine their effectiveness and identify where improvements are required.
- We need to be certain that workers are aware of the materials and chemicals they are using and that they are properly instructed regarding handling and medical care.

The Air Force has already procured aircraft that use composites in various components and airframes. In 1986 alone, the military aircraft market increased its use of composites by 12%, and higher figures are projected. Most of our front-line aircraft such as the F-16, F-4, B-52, and several cargo aircraft already have composites based on carbon or boron in their vertical and horizontal tail structures. The B-1 bomber, for example, has 1100 pounds of composites in six large, single-piece bomb-bay doors and lesser quantities in smaller components. The use of these composites is essential primarily in the main structural members to promote weight savings, reduce fatigue stress, increase tensile strength, and reduce corrosion to the airframe. Composites will play an ever-increasing role in building the B-2, ATF, C-17, new land and air-to-air missiles, and the military version of the Advanced Space Plane. We must continue to look into the future for solutions to our technology needs while ensuring that the exposures to our personnel are properly identified and assessed.

As industry develops more advanced formulations of composites and epoxy resin binders, our next step is to address the maintenance needs and the exposures they will bring. Continuous exposures to composite fibers in their natural state or those released by reworking, such as sanding, grinding, or drilling, can produce eye and skin irritations with possible long-term implications. Our logistics needs result in most occupational exposures and we must change work techniques to account for the use of composites. Phenolic paint stripping, a commonly used method of removing paint from our airframes during depot maintenance, cannot be used with composites because it dissolves the epoxy resin matrix. Excessive sanding to remove stubbornly bonded polyurethane coatings reduces the thickness of upper composites layers, thus reducing strength. New techniques such as laser painting, may be a viable alternative; however, we then face a new occupational hazard that will require more effective personal protection. As we solve the problems with composite materials, their future use in our airframes will become more routine.

I would now like to briefly discuss our experiences of applying toxicology to the Air Force's environmental mission of hazardous waste management and toxic waste cleanup. As I mentioned earlier, past practices of hazardous material and waste management have resulted in releases from disposal sites. Current law makes the Air Force responsible for remedial actions to achieve acceptable cleanup levels at contaminated sites on our installations, for cleaning up off-base contamination to

which we have contributed, and for paying the cost of past cleanup of privately owned facilities where Air Force wastes have been shipped. The funded cost of these efforts is over \$170M in FY89 against a requirement of \$280M, and an anticipated total need of over \$3B before we expect to complete the program.

With nearly all but a few of our preliminary assessments and site investigations completed, our efforts now focus on the need for assessing the nearly 3000 sites with hazardous waste releases and the techniques needed to remediate them. In the remedial investigation/feasibility stage, for example, releases must be confirmed and quantified before alternatives to remediate them can be generated. Rarely do we find situations where a single chemical is identified for cleanup. In most cases, it is a variety of chemicals or constituents within a single product that must be assessed. This complicates the decision-making process because our present knowledge of single chemicals toxicity is limited and usually requires, at best, speculation if one is to determine the synergistic effects of exposure. Any releases that have found their way to groundwater would further complicate the remediation process and increase the risk of exposure to our people and neighbors. It is the identification and association of risk in our feasibility studies that will drive many of the alternatives selected for cleanup.

Cleanup standards today for a given chemical vary not only state to state but also, in many cases, between federal, state, and local agencies. One of our most commonly used degreasers, trichloroethylene or TCE, which has been used since World War II, has seen cleanup levels of 25 ppb to as low as 2.5 ppb with most states accepting the 5-ppb drinking water level. I understand that the real level continues to be debated. As a federal environmental official, I will be pleased when there is a real consensus.

With the passage of the Superfund Amendments and Reauthorization Act (SARA) of 1986, toxicological emphasis on public exposure was built into the cleanup process. The National Contingency Plan, our nation's procedural guide for cleaning up Superfund sites, now requires an exposure assessment on each site on the National Priorities List (NPL). The Agency for Toxic Substances and Disease Registry of the Department of Health and Human Services is responsible for assessing these sites which presently includes 10 Air Force bases. Although, some additional bases will make the NPL, the vast majority will revert back to us for exposure assessment.

The Harry G. Armstrong Aerospace Medical Research Laboratory here at Wright-Patterson AFB published a compilation of toxicity data on the 70 most commonly seen chemicals at our installation restoration sites last year. Actual toxicity is a major concern because the risk to the population associated with a given cleanup alternative will most likely be the determining factor in the final

selection, rather than cost because of public perception that cancer can only be avoided if cleanup levels are zero.

We need to focus a portion of our research and development efforts on the data our field personnel and lawyers will require to negotiate cleanup levels with regulators. The Toxicology Guide was a start in the right direction, but we need more! Our limited toxicological resources will be tasked beyond capacity as our Installation Restoration Program begins its transition to the Feasibility Study stage, and cancer risk levels must be identified before the potentially costly final decision is made to proceed.

Earlier in my remarks I mentioned my concerns about the occupational health aspects of composites technology. As a result of my review of this subject, I have asked the Air Force Surgeon General and the Commander of the Air Force Systems Command Human Systems Division to begin planning for an Air Force-sponsored and hosted national symposium on the topic. While this is by no means an Air Force unique issue, it is, in my opinion, something that must be addressed by the entire aerospace industry and the occupational health professional community. The Air Force can and will lead in this investigation and we hope that all who are and should be interested – the entire aerospace industry, the occupational health and toxicology community, and labor – will participate. What we need are answers, not questions. However, the first step is to achieve a consensus on what are the questions, who ought to answer them, and what is the plan to get the answers.

Thank you for your attention and the opportunity to share a few thoughts with you on a very important topic.



**SESSION IV**

**ENVIRONMENTAL MODELING**

**Lt Colonel Harvey J. Clewell, III Chairman**

## HOUSEHOLD EXPOSURE MODELS

Thomas E. McKone

*Environmental Sciences Division,*

*Lawrence Livermore National Laboratory, P.O. Box 5507, L-453, Livermore, CA 94550*

### SUMMARY

Human exposure to volatile organic compounds (VOCs) in tap water is often assumed to be dominated by ingestion of drinking water. This paper addresses the relative importance of inhalation and dermal exposures in a typical household. A three-compartment model is used to simulate the 24-h concentration history of VOCs in the shower, bathroom, and remaining household volumes as a result of tap water use. Mass transfers from water to air are derived from measured data for radon and used to estimate mass-transfer properties for VOCs. The model is used to calculate a range of concentrations and human exposures in U.S. dwellings. The estimated ratio of household-inhalation uptake to ingestion uptake is in the range of 1 to 6 for VOCs. A dermal absorption model is used to assess exposure across the skin boundary during baths and showers. The ratio of dermal exposure to ingestion exposure is in the range 0.6 to 1.

### INTRODUCTION

Exposure assessment addresses the relation between the concentration of a contaminant in an environmental medium (air, soil, or water) and the amount available for human ingestion, inhalation, or dermal absorption. The traditional approach to exposure assessment relies on either measurements of a contaminant or its surrogate at a fixed monitoring location or mathematical model estimates of chemical concentrations given emissions data. One of the major weaknesses of the traditional approach has been the implicit assumption that population exposure is linked by simple parameters to ambient concentrations in air, water, or soil [1]. These simple parametric relations are illustrated best by the use of a water-ingestion rate of 2 L/day per 70 kg body weight as the bounding estimate for exposure to contaminants in tap water or the use of ambient outdoor concentrations for assessing human exposure to contaminants in air. Exposure assessments that include information on the characteristics of specific environments and the time/activity patterns of individuals such as those addressed in the total exposure assessment methodology (TEAM) studies [2] and the Harvard Health (6 cities) study [3] reveal the importance of providing a more complete picture of human exposure.

In its complete form, an exposure assessment should identify the source of a chemical; how much chemical, through transport and transformation, is available in the ambient air, water, and soil; how much of the available chemical comes in contact with humans and in what microenvironments; and which individuals or population subgroups are exposed. Furthermore, the analysis should quantify separate contributions by oral, dermal, and inhalation routes and the time dependence of the exposure.

In this paper, the household unit is selected as a subcomponent of the total environment for an exposure assessment. Tap water is assumed to be the sole source of contaminants to the household, and the question posed is "How much of the lifetime exposure through ingestion, dermal, and inhalation routes in the household is attributable to contaminants in tap water?" The answer to this question is formulated using models to represent exposure by each pathway. The models used here are taken from recent literature in public health risk assessment.

Efforts to assess human exposure to contaminated tap water have revealed that significant exposures to VOCs can occur from pathways other than the direct ingestion of water. Several researchers have investigated the relative importance of a variety of VOC exposure routes in the home from use of contaminated water supplies [4-8]. In addition, there have been studies of the contribution to indoor exposures of waterborne radon-222, another highly volatile substance [9, 10]. These studies indicate that exposure to volatile chemicals from routes other than direct ingestion of fluids may be as large as or larger than exposure from ingestion alone. These other routes include inhalation from indoor air of contaminants mobilized by showers, baths, toilets, dishwashers, washing machines, and cooking; ingestion of contaminants in food; and dermal absorption of contaminants while washing, bathing, and showering.

This paper is divided into five sections. The first section provides a background on a general approach for assessing human exposure to organic chemicals. This approach addresses relative contributions from ingestion, inhalation, and dermal absorption. The next three sections cover the methods used to estimate ingestion, inhalation, and dermal-absorption exposure factors. These factors convert water concentrations in milligrams per liter into human-population exposures in milligrams per kilogram of body weight per day. The final section presents a summary of the relative contributions of each pathway to total tap water derived exposure and concludes with a discussion of the exposure models. Also provided in the last section is a discussion of the inherent limitations, sensitivities, and possible conservatism in the models.

## BACKGROUND ON HUMAN-EXPOSURE ESTIMATES

The purpose of the human-exposure estimate is to provide a distribution of population exposures to a chemical present in environmental media. The exposure estimates form the basis for determining the absorbed doses, which are expressed as the amount of chemical absorbed or metabolized per unit body weight per day (milligram per kilogram per day).

### *Exposure, Dose, and Risk*

Exposure refers to human contact with a chemical or physical agent. Exposure can be expressed in terms of a concentration, such as the airborne level in milligrams per cubic meter, or in terms of the quantity that comes in contact with the human system through lung, gut wall, or skin, expressed in milligrams per day (or mg/kg/day). An individual breathing 20 m<sup>3</sup>/d of air containing 1 mg/m<sup>3</sup> is exposed to 20 mg/day, or for someone weighing 70 kg this could be expressed as an exposure of 2.9 mg/kg/day. Dose, or dose rate, expresses the amount of chemical actually absorbed into the body where it can be subsequently metabolized and/or transported to other tissues. Risk estimates are often based on the equivalent lifetime dose rate expressed in milligram per kilogram per day absorbed through the lung, skin, or gut.

A general approach for estimating the risk as the incidence of health effects within an exposed population is obtained from an expression of the form:

$$H = \int_0^{\infty} dD \int_0^{\infty} dR(D) n(D) p[R(D)] \quad (1)$$

where  $H$  is the expected number of health effects within the population;  $D$  is the absorbed dose, milligram per kilogram per day;  $R(D)$  is the risk factor that expresses the lifetime probability of health effects at a dose level in the range  $D$  to  $D + dD$ , kg-d/mg;  $n(D)$  is the number of people receiving a dose level in the range  $D$  to  $D + dD$ ; and  $p[R(D)]$  is the probability density function that expresses the probability that the dose/response function at dose level  $D$  has a value between  $R(D)$  and  $R(D) + dR(D)$ . At low exposure it is common to assume that the risk factor  $R(D)$  can be approximated by a linear function that is independent of dose rate  $D$ . In this case  $R(D) \sim q$ , where  $q$  is the cancer potency in kg- d/mg.

For the three pathways considered here – ingestion, inhalation, and dermal absorption – the total dose rate is given by the expression

$$D = \sum_{i=1}^3 E_i \alpha_i \quad (2)$$

where  $D$  is the total lifetime average absorbed dose rate, milligram per kilogram per day;  $i$  is the index referring to pathway ( $w$  = ingestion,  $a$  = inhalation,  $d$  = dermal absorption); and  $\alpha_i$  is the

absorption factor for the  $i^{\text{th}}$  pathway, unitless; and  $E_i$  is the daily average lifetime exposure rate by the  $i^{\text{th}}$  pathway, milligram per kilogram per day.

### **Anatomical and Dietary Parameters for Humans**

Table 1 lists values of human-body mass and surface area as a function of age. The lower portion of this table lists the values used in this study to characterize each of the major age categories: adult, child, and infant. The values listed include arithmetic means and standard deviations. The surface area as a function of body weight is calculated from a formula taken from the ICRP [11]:

$$SA = \frac{4W+7}{W+90} \quad (3)$$

in which SA is the surface area,  $m^2$ , and W is the body weight, kg.

**TABLE 1. HUMAN BODY WEIGHT AND SURFACE AREA BY AGE AND SEX (FROM ICRP, [11])**

Age (yr)	Sex	Mass (kg) <sup>a</sup>	Surface area <sup>a</sup> (m <sup>2</sup> )
Newborn	Male/female	3.5 ± 0.6	0.22 ± 0.02
1	Male/female	10 ± 2	0.47 ± 0.07
2	Male/female	12 ± 2	0.54 ± 0.06
4	Male/female	18 ± 2	0.73 ± 0.06
8	Male/female	26 ± 5	0.96 ± 0.1
12	Male/female	41 ± 8	1.3 ± 0.2
16	Male	62 ± 8	1.7 ± 0.1
	Female	55 ± 8	1.6 ± 0.1
20	Male	70 ± 10	1.8 ± 0.1
	Female	58 ± 9	1.6 ± 0.1
40	Male	75 ± 10	1.8 ± 0.1
	Female	62 ± 10	1.7 ± 0.2
Infant (Newborn to 2 yr)	Male/female	8.5 ± 3	0.42 ± 0.1
Child (2 to 16 yr)	Male/female	32 ± 16	1.1 ± 0.4
Adult (16 to 70 yr)	Male	73 ± 10	1.8 ± 0.1
	Female	60 ± 9	1.6 ± 0.1

<sup>a</sup> Arithmetic mean ± one standard deviation.

The standard deviation in surface area is calculated as the product of the derivative of surface area with respect to body weight (W) and the standard deviation in body weight.

Table 2 provides values of the hourly breathing (ventilation) rate by age and activity level. Also provided are the daily average breathing rates based on the time spent at rest or awake and the daily average breathing rate per unit body weight. These values represent the volume of air that enters and leaves the lungs within a one-hour period. Time-varying exposures are estimated using these data to determine that the infant, child, and adult breathe, respectively, 29, 24, and 17 L/kg-h during waking hours and 11, 9, and 6.1 L/kg-h while resting. Combining these values using weighting factors corresponding to fraction of years and time of day an individual spends in each breathing category and using body weights appropriate for each category gives a lifetime average daily breathing rate of approximately 20,000 L/day.

**TABLE 2. REFERENCE BREATHING RATES FOR INFANTS, CHILDREN, AND ADULTS (FROM ICRP [11])**

Activity	Infant (1 year)		Child (10 year)		Adult Female		Adult Male	
	L/h	(h/day)	L/h	(h/day)	L/h	(h/day)	L/h	(h/day)
Working, light activity, or recreation	250	(10)	780	(16)	1,100	(16)	1,200	(16)
Resting	93	(14)	288	(8)	360	(8)	450	(8)
L/h								
Daily average	160		620		850		950	
L/kg-h								
Daily average breathing rate per unit body weight	160		620		850		950	

Table 3 lists reference values for intake of fluids by infants, children, and male and female adults. The information is listed by fluid source. Tap water refers to direct consumption of tap water. Other sources of fluids refer to all intakes of fluids, exclusive of milk and direct tap-water consumption. It should be noted that intake of fluid in beverages such as coffee, tea, and soft drinks may consist of indirect tap-water consumption. Also listed in Table 3 is the fluid intake per unit body

weight. This factor includes total fluid intake per unit body weight. For infants and children, this ratio is relatively high, 0.11 and 0.044 L/kg/day, respectively. For adults, this ratio is 0.023 L/kg/day for women and 0.029 L/kg/day for men, with a combined adult value of about 0.026 L/kg/day.

**TABLE 3. FLUID INTAKES FOR INFANTS, CHILDREN, AND ADULTS (FROM ICRP [11])**

	L/d			
	Infant (1 year)	Child (10 year)	Adult Female	Adult Male
Milk	0.9	0.45	0.2	0.3
Tap water	—	0.2	0.1	0.15
Other <sup>a</sup>	—	<u>0.75</u>	<u>1.1</u>	<u>1.5</u>
Total fluids	0.9	1.4	1.4	2.0
	L/kg/day			
Fluid intake per unit body weight	0.11	0.044	0.023	0.029

<sup>a</sup> Includes tea, coffee, soft drinks, beer, and other beverages.

#### **Pathway-Exposure Factors for Tap-Water Exposure Routes**

Pathway-exposure factors (PEFs) are used to link contaminant concentrations in tap water,  $C_w$ , to an exposure rate. The PEFs incorporate information on human physiology, anatomy, and behavior patterns and environmental transport into a term that translates the contaminant concentration in tap water, milligrams per liter, into a daily exposure in mg/kg/day for a specified route (i.e., ingestion, inhalation, dermal). For exposure to tap water there are three PEFs: (1) water ingestion,  $F_{ww}$ ; (2) water/inhalation,  $F_{wa}$ ; and (3) water/dermal absorption,  $F_{wd}$ .

Because regulatory agencies are often interested in the equivalent lifetime exposure within a population composed of three age categories (infant, child, and adult), the overall exposure factor is the weighted sum of the pathway-exposure factors for each of the three age categories. For example, the pathway exposure factor,  $F_{wa}$ , for water by inhalation can be divided into three components

$$F_{wa} = \frac{2}{70} f_{wa} (\text{infant}) + \frac{14}{70} f_{wa} (\text{child}) + \frac{54}{70} f_{wa} (\text{adult}) \quad (4)$$

In this expression, the factors 2/70, 14/70, and 54/70 reflect the fraction of time the population cohort spends in each of the age categories. It also is assumed that the population is stationary and that the contaminant concentration in tap water is constant over the 70-year exposure period. If this is not the case, then the concentration should be modified appropriately.

### PATHWAY-EXPOSURE FACTORS FOR DRINKING WATER

For the water-ingestion pathway, the  $F_{ww}$  parameter for each age category is obtained by dividing daily water intake by body weight. The ratio of fluid intake to body weight for each age group comes from Table 3. Data compiled by the ICRP [11] on fluid intake by adults at high environmental temperatures and during moderate activity reveal that at high environmental temperatures (to 32°C) adults consume 2.8 to 3.4 L/day of fluids and that moderately active adults can consume 3.7 L/day. Using an adult weight of 66.5 kg from Table 1, this corresponds to a fluid intake as high as 0.056 L/kg-day. Assuming that all fluids consumed by the members of a household with contaminated water are at the same concentration, estimates of the ingestion pathway-exposure factor are bracketed using the lifetime average fluid intake per unit body weight derived from Table 3 as the reference value and the fluid intake by moderately active adults as the upper bound. Thus,  $F_{ww}$  can be estimated to be in the range

$$F_{ww} = \frac{2}{70} \times 0.11 + \frac{14}{70} \times 0.044 + \frac{54}{70} \times 0.026 \quad (5)$$

$$= 0.032 \text{ mg/kg-d per mg/L, and}$$

$$F_{ww} = \frac{2}{70} \times 0.11 + \frac{14}{70} \times 0.044 + \frac{54}{70} \times 0.056 \quad (6)$$

$$= 0.055 \text{ mg/kg-d per mg/L}$$

The reference value, 0.032 (mg/kg/day)/(mg/L) is similar to the value obtained under the assumption that intake of drinking water over a lifetime approximates 2 L/70 kg/day or 0.028 (mg/kg/day)/(mg/L). Cothern et al. [4] reported that a weighted average derived from water-consumption curves gives a lifetime exposure factor on the order of 0.034 (mg/kg/day)/(mg/L). The upper-bound limit in Equation 6 corresponds to a lifetime average daily fluid intake of 3.8 for a 70 kg adult. To date, population studies on the variability of water consumption have not been conducted in the United States [4]. However, the Canadian Environmental Health Directorate [12] has studied the variability of water consumption in Canada and found 13 to 16% of adults may consume more than 2 L/day of fluid. Nonetheless, it should be recognized that the PEF in Equation 5 provides a conservative reference estimate because it includes all fluid intake and not just tap water. The upper bound PEF in Equation 6 should be used for situations where the assumption of large intake from tap water can be justified, or for estimating maximum acute exposures.

### PATHWAY-EXPOSURE FACTORS FOR INHALATION

McKone [8] has developed a model that describes the daily concentration profile of VOCs within the various components of the indoor air volume of a dwelling. For the model, the indoor air volume is divided into three compartments – the shower/bath stall, the bathroom, and the household



volume. This is shown in Figure 1. This model is used to calculate two bounding pathway-exposure factors that relate inhalation exposure to the use of contaminated water in a household. One corresponds to the average daily lifetime exposure to an individual living in a "typical" household. The other represents an upper bound estimate of exposure in which the model parameters are set at values that provide a conservation upper limit on exposure and dose estimates.

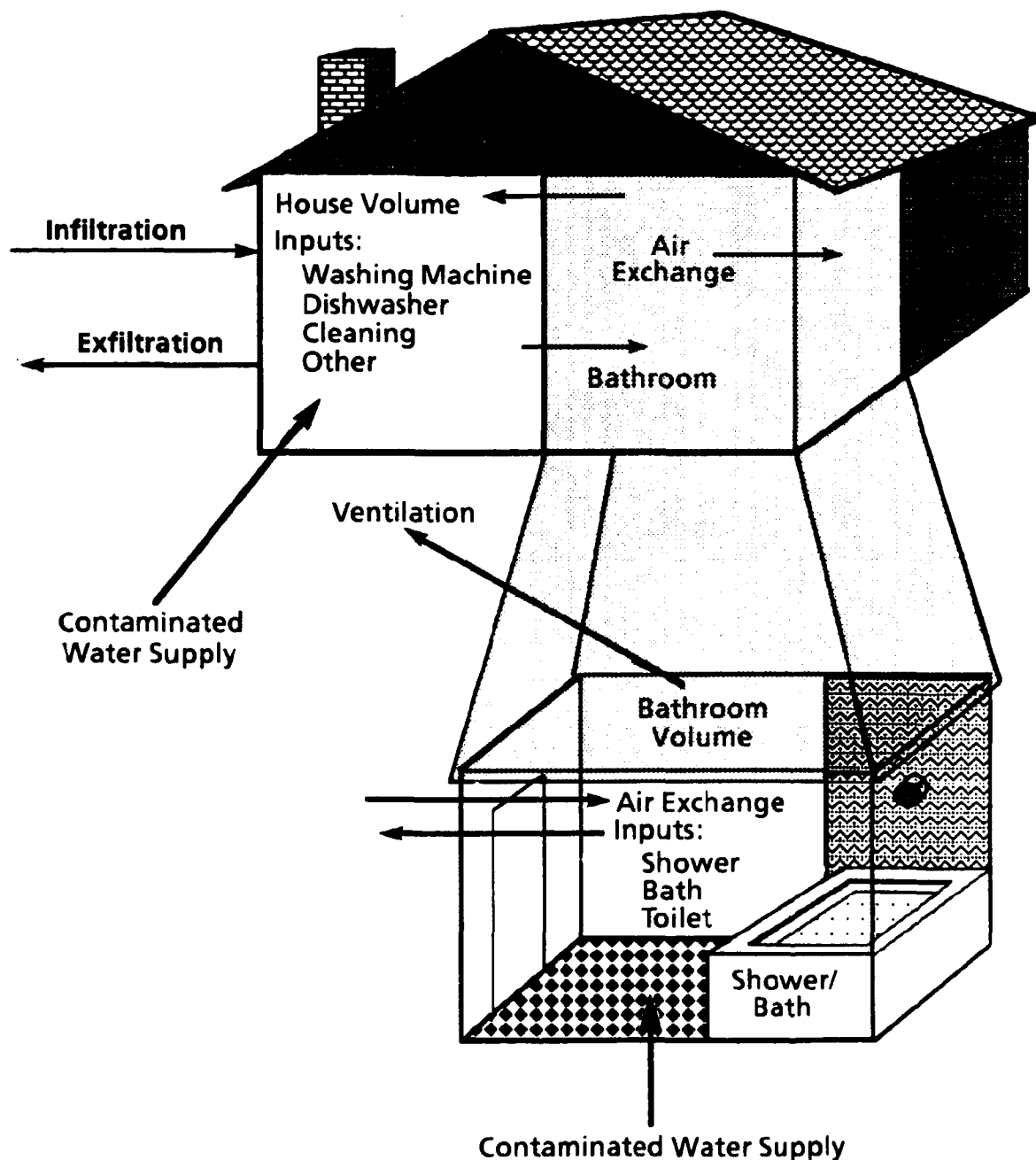


Figure 1. Dispersion of Chemicals from Tap Water to the Indoor Environment.

For each compartment in the indoor model, the time-dependent chemical concentration is obtained by solving the differential equation that balances the time rate of change of contaminant mass to the instantaneous difference between gains and losses. The mass-balance equations for the three compartments take the following forms:

for the shower stall,

$$V_s \frac{dC_s(t)}{dt} = Q_s(t) + q_{bs}C_b(t) - q_{sb}C_s(t), \quad (7)$$

for the bathroom,

$$V_b \frac{dC_b(t)}{dt} = Q_b(t) + q_{sb}C_s(t) - q_{ab}C_a(t) - (q_{bs} + q_{bo} + q_{ba})C_b(t), \quad (8)$$

and for the remainder of the house,

$$V_a \frac{dC_a(t)}{dt} = Q_a(t) + q_{ba}C_b(t) - (q_{ab} + q_{ao})C_a(t). \quad (9)$$

In the above equations, the  $C$ s refer to concentrations, mg/L; the  $V$ s refer to volumes, L; and the  $Q$ s refer to sources, mg/min. The subscripts  $s$ ,  $b$ , and  $a$  are used to indicate the shower, bathroom, and remaining household compartments, respectively. The  $q$ 's are used to represent air-exchange rates, L/min, with the subscripts identifying the source and endpoint of the transfer. For example, the mass transfer,  $q_{sb}$ , refers to an exchange from shower air,  $s$ , to bathroom air,  $b$ ;  $q_{ba}$  refers to the air exchange from bathroom to household air. The air-exchange parameters,  $q_{bo}$  and  $q_{ao}$ , refer to air transfers from the bathroom and household compartments to outside air. The air-exchange parameters,  $q$ , are derived from the following relationships:

$$q_{sb} = q_{bs} = \frac{V_s}{R_s}, \quad (10)$$

$$\frac{V_b}{R_b} = q_{ba} + q_{bo}, \quad (11)$$

$$q_{bo} = f_o q_{bo}, \quad (12)$$

$$q_{ba} = q_{ab} - q_{bo}, \quad (13)$$

$$\frac{V_a}{R_a} = q_{ao} + q_{ab}, \quad (14)$$

in which  $R_s$ ,  $R_b$ , and  $R_a$  are the residence times of air volumes in the shower, bathroom, and household air compartments; and  $f_o$  is the fraction of air entering the bathroom that is exhausted directly to outside air by ventilation.

The source terms  $Q_s(t)$ ,  $Q_b(t)$ , and  $Q_a(t)$  are used to account for the input of a volatile chemical from the use of contaminated water in each respective household compartment. Because we are only interested in estimating the indoor concentration attributable to contaminated water supplies, the concentration of a contaminant in ambient air is ignored. The general form of the source term for an arbitrary compartment,  $i$ , has the form

$$Q_i(t) = \frac{I_i \phi_i H(t, t_i^o, t_i^*)}{(t_i^* - t_i^o)} C_w, \quad (15)$$

where  $Q_i(t)$  is the time-dependent source term in the  $i$ th compartment, mg/min;  $I_i$  is the total amount of water consumed daily by activities in compartment  $i$ , L;  $\phi_i$  is the efficiency for transfer (mg/L transferred divided by milligram per liter initial concentration) of the chemical from water to air for water use in compartment  $i$ ;  $H(t, t_i^o, t_i^*)$  is the function whose value is 1 when  $t$  is between  $t_i^o$  and  $t_i^*$  and zero otherwise, unitless;  $t_i^o$  is the time at which water use in compartment  $i$  begins, min;  $t_i^*$  is the time at which water use in compartment  $i$  ends, min; and  $C_w$  is the contaminant concentration in the water supply, mg/L.

In the current version of the model, all water uses are combined into three activities: (1) showers/baths in the shower stall, (2) toilet use in the bathroom, and (3) all other water uses in the remainder of the house.

The transfer efficiencies  $\phi_s$ ,  $\phi_b$ , and  $\phi_a$ , which are crucial inputs to this model, have only been measured directly for trichloroethylene (TCE) [6, 7]. However, several measurements of these transfer efficiencies for the naturally occurring radioactive gas radon have been made by Prichard and Gesell [9] for homes in the Houston area and by Hess et al. [10] for homes in Maine. These measured transfer efficiencies are listed in Table 4 where it can be seen that the two data sets are consistent. In addition, the transfer efficiency for TCE measured by Andelman [6, 7] in a model shower is similar to the measured values in Table 4 for radon.

In assessing the transfer of volatile organics from water to indoor air, MacKay and Paterson [13] have shown that both radon and volatile compound mass transfer from water to air can be modeled using a "two resistance" approach. In this approach the overall mass transfer, through liquid and air reflects resistance through both the liquid and gas phases. McKone [8] has shown that the two-resistance model, when combined with elementary models of mass transfer, can be used to estimate transfer efficiencies for one chemical species using measured values for another. He used

**TABLE 4. THE RADON-TRANSFER EFFICIENCY FROM AIR TO WATER REPORTED BY PRICHARD AND GESELL [9] AND BY HESS ET AL. [10] TOGETHER WITH WATER CONSUMPTION BY CATEGORY OF USE**

	Radon Transfer Efficiency (%)		Water Consumption
	Prichard and Gesell [9]	Hess et al. [10]	Daily use <sup>a</sup> L/person-day
Toilets	30	30	35 to 95
Showers	63	65	25 to 75 <sup>b</sup>
Baths	47	30	
Laundry	90	90	28 to 44
Dishwasher	90	98	14
Kitchen and sinks	30	30	19 to 68
Cleaning	90	-	13 to 30
<b>Total</b>			<b>130 to 330</b>

<sup>a</sup> Derived from Bond et al. 1973 [14] and Siegrist 1983 [15].

<sup>b</sup> Showers and baths reported together.

this model to show that measured transfer efficiencies for TCE can be predicted using radon transfer efficiencies. In this model the transfer efficiency for species other than radon is calculated under the assumption that the transfer efficiency is in proportion to the overall mass-transfer coefficient,  $K$ , at the liquid/gas boundary. The transfer efficiency is calculated as

$$\Phi_i^j = \Phi_i^{Rn} \frac{K(j)}{K(Rn)} = \Phi_i^{Rn} \frac{\left( D_\ell^{\frac{2.5}{2\beta}} + D_a^{\frac{RT}{2\beta}} H \right) Rn}{\left( D_\ell^{\frac{2.5}{2\beta}} + D_a^{\frac{RT}{2\beta}} H \right) j} \quad (16)$$

where  $\Phi_i^j$  is the transfer efficiency for species,  $j$ , in water use,  $i$ , unitless; and  $\Phi_i^{Rn}$  is the transfer efficiency for radon as reported by Prichard and Gesell [9] and Hess et al. [10] for water use,  $i$ , unitless.  $D_\ell$  is the contaminant diffusion coefficient in water ( $m^2/s$ );  $D_a$  is the contaminant diffusion coefficient in air ( $m^2/s$ );  $R$  is the gas constant (torr-L/mol-K);  $T$  is the temperature ( $\sim 293K$ ). For many organic compounds,  $D_a$  is on the order of  $5 \times 10^{-6} m^2/s$  and  $D_\ell$  is on the order of  $5 \times 10^{-10} m^2/s$ . Table 5 lists mass-transfer data and corresponding transfer efficiencies for radon and seven VOCs: carbon tetrachloride, chloroform, dibromochloropropane, ethylenedibromide, perchloroethylene, trichloroethane, and trichloroethylene.

TABLE 5. MASS-TRANSFER PROPERTIES FOR RADON AND SEVEN VOCs AT 20°C<sup>a</sup>

Compound (j)	Diffusion Coefficient in Water (m <sup>2</sup> /s)	Diffusion Coefficient in Air (m <sup>2</sup> /s)	Henry's Law Constant (torr-m <sup>3</sup> /mol) <sup>b</sup>	$\frac{K(j)}{K(R_n)}$
Radon	1.4 × 10 <sup>-9</sup>	2.0 × 10 <sup>-5</sup>	70 <sup>c</sup>	1.0
Carbon tetrachloride	8.2 × 10 <sup>-10</sup>	7.8 × 10 <sup>-6</sup>	17	0.70
Chloroform	9.2 × 10 <sup>-10</sup>	8.7 × 10 <sup>-6</sup>	2.4	0.75
Dibromochloropropane	7.2 × 10 <sup>-10</sup>	6.9 × 10 <sup>-6</sup>	0.18	0.59
Ethylenedibromide	8.9 × 10 <sup>-10</sup>	8.1 × 10 <sup>-6</sup>	740	0.74
Perchloroethylene	7.6 × 10 <sup>-10</sup>	7.4 × 10 <sup>-6</sup>	21	0.66
Trichloroethane	8.1 × 10 <sup>-10</sup>	7.8 × 10 <sup>-6</sup>	3.0	0.69
Trichloroethylene	8.1 × 10 <sup>-10</sup>	7.8 × 10 <sup>-6</sup>	8.0	0.69

<sup>a</sup> Calculated using property-estimation methods described in Lyman et al. [16] unless otherwise noted.

<sup>b</sup> Estimated as the ratio of vapor pressure to solubility. Vapor pressure and solubility data are taken from Verschueren [17].

<sup>c</sup> Derived from Mackay and Paterson [13].

#### Model Parameters

There are four types of input data required by the indoor model: (1) house and room volumes, (2) residence times for air in each household volume, (3) water use by category, and (4) amount of time individuals spend in the shower, bathroom, and remaining house.

The volume of the house is assigned a value of 400 m<sup>3</sup> based on Prichard and Gesell's [9] observation that household volumes in the Houston area are in the range 150 to 680 m<sup>3</sup>. The volume of the bathroom is assumed to be 10 m<sup>3</sup> with a likely range between 5 and 50 m<sup>3</sup>. The volume of the shower stall is assumed to be 2000 L with a likely range between 1200 and 3000 L.

Andelman [6, 7] has measured the residence time of the air mass in a shower to be on the order of 20 min and this value is used in the model. The residence time of the entire household air volume is given a reference value of 120 min with a range of 30 to 240 min [8]. The residence time of air in the bathroom is assumed to be 30 min.

Total water use for the reference household is based on the assumption that there are four occupants consuming 250 L/day per individual for all indoor uses. Each individual is assumed to use 75 L in showers or baths. These values are derived from ranges of values reported in Bond et al. [14] and Siegrist [15], which are summarized in Table 4.

In a survey of 2550 households in western Australia, James and Knuiiman [18] report an average shower flow rate of approximately 9 L/min with households reporting values as high as 22 L/min.

They also found an average shower duration of 8 min with 2% of the individuals reporting shower duration in excess of 20 min .

In order to ensure that the reference case is both representative and conservative, a shower/bath duration of 10 min is assumed.

### **Daily Concentration Profiles**

The time-dependent concentration profiles of a chemical in shower-stall air, bathroom air, and household air are used to calculate daily human exposure through inhalation using the following formula

$$E = \frac{1}{BW} \int_0^{24} \left[ OF_s(t)C_s(t) + OF_b(t)C_b(t) + OF_a(t)C_a(t) \right] BR(t) dt \quad (17)$$

where  $E$  is the daily exposure rate to an individual occupant of the house, mg/kg-d;  $BW$  is the body weight of the individual, kg;  $OF_s(t)$  is an occupancy factor which expresses the probability that an individual is in the shower at the time,  $t$ , unitless;  $OF_b(t)$  is the occupancy factor for the bathroom time  $t$  (unitless); and  $OF_a(t)$  is the occupancy factor for the remaining household volume at the time,  $t$ , unitless; and  $BR(t)$  is the breathing rate of an individual at time,  $t$ , L/min. The probability distributions used to represent the three occupancy factors are uniform distributions. Details on how these distributions are applied are provided in McKone [8].

Daily dose rates are calculated for adults, children, and infants. Adults are individuals from ages 16 to 70 year, who are assumed to weigh 67 kg and breathe 20 L/min for 16 h/day while active and 6.6 L/min for 8 h/day while resting. Children are individuals from ages 2 to 16 year, who are assumed to weigh 32 kg and breathe 13 L/min for 16 h/day while active and 4.8 L/min for 8 h/day while resting. Infants are individuals from ages 0 to 2 year, who are assumed to weigh 8.5 kg and breathe 4.2 L/min for 10 h/day while active and 1.6 L/min for 14 h/day while resting.

The time-dependent concentration profile in the shower stall, bathroom, and household air and the resulting effective lifetime doses are estimated using two sets of assumptions. These assumptions are intended to define typical values and a likely upper limit on dose. The two sets of assumptions are listed below.

#### Assumptions use for typical doses

- Occupants spend 100% of their time in the house from 11:00 pm to 7:00 am.
- Bathroom is used for showers/baths from 7:00 am to 8:00 am (shower use during this period is not necessarily continuous).
- Each adult and child spends 20 min in the bathroom during the period from 7:00 am to 9:00 am.

- Each adult and child spends an additional 20 min in the bathroom during any 22-h period (excluding the hours 7:00 am to 9:00 am).
- Each adult spends 10 min in the shower or bath.
- Adults spend 25% of the time from 7:00 am and 11:00 pm in the house.
- Children spend an average of 20 min/week in showers or baths.
- Children spend 60% of the time between 7:00 am and 11:00 pm in the house.
- Infants spend 100% of their time in the house and 2% of that time in a bathroom.
- Fifty percent of the PCE inhaled is available for pulmonary uptake. (This assumption reflects the fact that the full lung volume is not necessarily the active exchange boundary for uptake of volatile chemicals.)

#### Assumptions used for upper-bound doses

- Each adult and child spends 40 min in the bathroom between 7:00 am and 9:00 am.
- The bathroom is used for showers/baths from 7:00 am to 8:30 am.
- Each adult spends 20 min in the shower or bath.
- All age groups spend 90% of their time in the house.
- Children spend an average of 40 min/week in showers or baths.

This model has been used to estimate the inhalation-pathway-exposure factors for the seven VOCs listed in Table 6. These numbers are based on the assumption that an adult showers every day and that children bathe every second day. For adults or children who take baths instead of showers these numbers are likely to be reduced somewhat. The extent of reduction that taking baths in place of showers would give has not been assessed. Exposures to adults in the shower and bathroom are the major contributors to indoor inhalation exposures attributable to contaminated water. A local sensitivity analysis of the different parameters involved in the calculation of the pathway dose factor for the inhalation route of exposure has been developed by McKone [8]. According to that analysis, the pathway-exposure factor was most sensitive to changes in the following parameters: the transfer efficiency of a VOC in shower water to air, the water use of individuals in showers, and the ratio of breathing rate to body weight (adult).

Although the assumption that adults spend 25% of the time from 7:00 am to 11:00 pm in the house may seem low, we believe this is a plausible value for a typical adult who spends 10 h/day in work and travel, leaving 6 h of leisure time of which we assume roughly two-thirds is actually spent in the home.

**TABLE 6. VALUES OF THE LIFETIME INHALATION-PATHWAY-EXPOSURE FACTORS CALCULATED FOR SEVEN VOCs USING THE THREE-COMPARTMENT MODEL FOR INDOOR EXPOSURES**

Compound	Pathway Exposure Factor for Indoor Inhalation Attributable to a Unit Concentration in Water Supplies (mg/kg/day) / (mg/L)	
	Reference Estimate	Upper-Bound Estimate
Carbon tetrachloride	0.084	0.34
Chloroform	0.090	0.36
Dibromochloropropane	0.046	0.22
Ethylenedibromide	0.088	0.36
Perchloroethylene	0.078	0.32
Trichloroethane	0.082	0.32
Trichloroethylene	0.082	0.32

#### PATHWAY-EXPOSURE FACTORS FOR DERMAL ABSORPTION

Over the last 20 year, several investigators have examined the transport of dissolved chemicals across the skin [4, 19-24]. Although a complex process, dermal uptake of compounds occurs mainly through passive diffusion through the stratum corneum.

It is assumed here that dermal absorption occurs during bathing and showering. The PEF for dermal absorption is based on the following simplifying assumptions.

- Resistance to diffusive flux through layers other than the stratum corneum is negligible.
- Steady-state diffusive flux is proportional to the concentration difference between the skin surface and internal body water.
- An adult spends from 10 to 20 min in a bath or shower each day.
- During bathing, roughly 80% of the skin is in contact with water, and during showers, roughly 40% of the skin is in contact with water.
- Children and infants spend approximately 1 h/wk in bathing or swimming [25].

The exposure from dermal absorption is given by the expression

$$E = J_s \tau f_s SA, \quad (18)$$

where  $J_s$  is the steady-state flux across the stratum corneum, mg/cm<sup>2</sup>-h;  $\tau$  is the duration in the shower or bath, h;  $f_s$  is the fraction of the skin surface in contact with water, unitless; and  $SA$  is the surface area of the skin, cm<sup>2</sup>.



Chemical transport across the skin is assumed to follow Fick's law, so that the flux  $J_s$  across skin tissue is given by

$$J_s = K_p \Delta C_s, \quad (19)$$

where  $K_p$  is the permeability constant across the stratum corneum, L/cm<sup>2</sup>/h; and  $\Delta C_s$  is the concentration difference of the solute across the tissue, mg/L.

Brown et al. [21] have determined, from an analysis of chemical transfer through the skin layer, that  $K_p$  is on the order of 0.001 L/cm<sup>2</sup>/h for VOCs. They used this value to characterize  $K_p$  for six measured skin-absorption rates on four different chemicals. In these experiments,  $K_p$  ranged from 0.0006 to 0.001 L/cm<sup>2</sup>/h. For dilute solutions,  $\Delta C_s$  is approximately equal to the chemical concentration at the skin surface. However, the concentration at the skin surface is not necessarily the same as the concentration in the water supply. For showers and baths it is assumed here that

$$C_s = (1 - \phi_s) C_w, \quad (20)$$

where  $C_w$  is the contaminant concentration in tap water and  $\phi_s$  is the transfer efficiency from water to air in showers and baths.

Equations 18 and 19 can be substituted into Equation 4 to obtain a lifetime equivalent dose factor for dermal absorption,

$$F_{wd} = K_p \frac{2}{70} (\tau \times f_s \times \frac{SA}{BW} \times C_s)_{infant} + \frac{14}{70} (\tau \times f_s \times \frac{SA}{BW} \times C_s)_{child} + \frac{54}{70} (\tau \times f_s \times \frac{SA}{BW} \times C_s)_{adult}, \quad (21)$$

in which  $BW$  represents body weight in kg,  $SA$  represents surface area in cm<sup>2</sup>, and  $\tau$  the duration of bath or shower. With water containing 1 mg/L and a 10-min bath, the term,  $\tau \times f_s \times C_s$ , is on the order of 6 min/mg/L, whereas for a 10-min shower this term is roughly 4 min/mg/L. For a 15-min shower the term is 6 min/mg/L. Thus, given the uncertainty in the overall exposure estimate, a 10- or 20-min bath might be considered as an appropriate representation for the reference and upper-bound estimates of dermal absorption during both baths and showers. However, it should be noted that Fick's law may not apply when water is running off the skin in a shower.

Based on data from Table 1, the ratios  $SA/BW$  for adults, children, and infants are respectively 260, 340, and 490 cm<sup>2</sup>/kg. As suggested by Brown et al. [21], the factor  $f_s$  is assumed to be on the order of 0.8. Listed below is a sample calculation for perchloroethylene (PCE) with  $\phi_s = 0.5$  and thus  $C_s = 0.5 C_w$ . Substituting the appropriate values into Equation 21 gives the following limits on  $F_{wd}$ .

Reference estimates (assuming 10-min bath for adults):

$$= 0.019 \frac{\text{mg}}{\text{kg-d}} \text{ per } \frac{\text{mg}}{\text{L}} \quad (22)$$

Higher estimate (assuming 20-min bath for adults):

$$= 0.037 \frac{\text{mg}}{\text{kg-d}} \text{ per } \frac{\text{mg}}{\text{L}} \quad (23)$$

## SUMMARY AND DISCUSSION

Table 7 provides a summary of the three pathway-exposure factors, including the reference estimate and the limiting or upper bound values. The pathway-exposure factors are used to convert the water-supply concentration of PCE,  $C_w$ , (mg/L) into an equivalent lifetime average dose rate in milligram per kilogram per day. Thus, the pathway-dose factor serves to account for the exposure conditions within a population.

Table 7 also lists the lifetime average fluid intake of contaminated water that would give the equivalent exposure to a 70-kg adult. These values are listed for comparison. Finally, Table 7 lists the percent of the lifetime equivalent exposure contributed by each pathway.

**TABLE 7. SUMMARY OF THE PATHWAY EXPOSURE FACTORS FOR PERCHLOROETHYLENE**

Pathway	Fluid Ingestion	Indoor Inhalation	Dermal Absorption	Total
Variable =	$F_{ww}$	$F_{wa}$	$F_{wd}$	$F_w = \Sigma F_{wi}$
<u>Reference estimates:</u> <sup>a</sup> (mg/kg/d) / (mg/L)	0.031	0.078	0.019	0.128
Equivalent lifetime daily fluid intake by 70-kg adult, L	2.2	5.46	1.3	9.0
Percent of total	24	61	15	100
<u>Upper bounds:</u> <sup>b</sup> (mg/kg/d) / (mg/L)	0.055	0.32	0.032	0.41
Equivalent lifetime daily fluid intake by 70-kg adult, L	3.8	22.4	2.2	28.4
Percent of total	13	79	8	100

<sup>a</sup> For use in estimating the likely value of lifetime equivalent exposure within a population.

<sup>b</sup> For use in estimating maximum acute exposure or to represent individuals whose activity patterns put them in the upper percentile groups for chronic exposure.

The goal of this paper was to outline a procedure for estimating human exposure to multiple household pathways associated with contaminated tap water. One of the important next steps is a systematic evaluation of uncertainties. This report has laid some of the groundwork for this process. Human inhalation and ingestion parameters are reported as the arithmetic means of probability

distributions with the corresponding standard deviations. It remains for someone to develop such distributions for the many other parameters used in the integrated exposure assessment. Once this is done, it will be possible to calculate the uncertainty in each PEF and identify the principal sources of the uncertainties. Using this procedure, one can identify parameters that must be characterized more precisely when making decisions about managing health risk through exposure reductions. It is difficult to make definitive conclusions about the results of this work until such a sensitivity/uncertainty analysis is completed.

It is important to recognize that the results provided here are based on model results and have been substantiated only by limited experimental data. These models are intended for assessing likely ranges of exposure but not for making definitive predictions. For each exposure pathway a reference PEF and upper bound PEF is provided. The reference PEF is intended to use in assessing chronic long-term exposures. The upper value is for use in assessing acute exposures or to represent uptake by individuals whose daily activity patterns put them in the upper percentile groups for exposure.

The inhalation exposure model has been compared to some measured results for TCE and chloroform [8]. In an experimental shower using water with a TCE concentration of 3.8 mg/L, Andelman [6] observed TCE concentrations in shower air in the range 50 to 80 mg/m<sup>3</sup>. The model described here projects shower concentrations in the range 70 to 100 mg/m<sup>3</sup> for this TCE concentration in water. In the TEAM studies [2], measured chloroform in indoor air attributable to water supplies was found to have a ratio of air concentration to water concentration that ranged from 0.014 to 0.23 (µg/m<sup>3</sup>)/(µg/L). These were measurements of personal air that excluded time spent in bathrooms and showers. The indoor model described in this paper predicts the ratio of chloroform concentration in household air (excluding bathroom and shower) to concentration in water to be in the range 0.03 to 0.10 (µg/m<sup>3</sup>)/(µg/L).

It also should be noted that for people who take baths the reference estimate for inhalation uptake should be used with caution, and, similarly, for people who take showers the reference estimate for dermal uptake should be used with caution. It is likely that mass transfer from bath water to indoor air is lower than for showers; but how much lower has not been quantified at this time. In addition, in a shower as opposed to a bath it may not be reasonable to assume that chemical transport across the skin follows Fick's law when water is running rapidly off the skin. Again, the expected reduction in exposure is difficult to quantify.

It also should be noted that the assumptions used to account for ingestion uptake do not account for losses of volatile compounds that can occur during cooking and processing. When these losses are accounted for the relative importance of the inhalation and dermal pathways is likely to increase.

Although the results in this report have not been subjected to a rigorous sensitivity or uncertainty analysis, there are some conclusions that can be drawn regarding the numbers in Table 7 and the results of sample calculations. Listed below are two of the more important conclusions.

1. Inhalation of volatile chemicals transported from potable water supplies to indoor air has the potential for being as important as or more important than the direct ingestion of these compounds as a route of exposure from potable water supplies.
2. The dermal absorption of chemicals from bath and shower water is based on limited data defining the permeability of the skin to chemical transport. The estimate for this parameter used here was based on measurements from a handful of VOCs. The accuracy of this model and its application to a broad spectrum of chemicals are questionable. However, because the model in question is conservative, it is likely that improving the resolution in this PEF may result in lower estimates of exposure by this route.

#### ACKNOWLEDGMENTS

Work performed under the auspices of the U.S. Department of Energy by Lawrence Livermore National Laboratory under contract number W-7405-ENG-48. Funding was from the California Department of Health Services, Toxic Substances Control Division, and from the Harry G. Armstrong Aerospace Medical Research Laboratory, Wright-Patterson Air Force Base. David W. Layton of Lawrence Livermore National Laboratory has provided review, comments, and consultation of this work.

#### REFERENCES

- 1 Lioy, P.J. (1987) In-depth exposure assessment. *Air Pollut. Control Assoc.* 37, 791-793.
- 2 Wallace, L. (1986) An Overview of the Total Exposure Assessment Methodology (TEAM) Study, Vol. 1, Final Report, U.S. EPA, Washington, DC.
- 3 Spengler, J.D., Docker, D.W., Turner, W.A., Wolfson, J.M. and Ferris, B.G. Jr. (1981) Long-term measurements of respirable sulfates and particles inside and outside homes. *Atmos. Environ.* 15, 23-30.
- 4 Cothorn, C.R., Coniglio, W.A. and Marcus, W.L. (1984) Techniques for the Assessment of the Carcinogenic Risk to the U.S. Population due to Exposure from Selected Volatile Organic Compounds from Drinking Water via the Ingestion, Inhalation and Dermal Routes. EPA Office of Drinking Water (WH-550): Washington, DC, PB84-213941.
- 5 Shehata, A.T. (1985) A multi-route exposure assessment of chemically contaminated drinking water. *Toxicol. Ind. Health* 4, 277-298.
- 6 Andelman, J.B. (1985) Human exposures to volatile halogenated organic chemicals in indoor and outdoor air. *Environ. Health Perspect.* 62, 313-318.
- 7 Andelman, J.B. (1985) Inhalation exposure in the home to volatile organic contaminants of drinking water. *Sci. Total Environ.* 47, 443-460.

- 8 McKone, T.E. (1987) Human exposure to volatile organic compounds in household tap water: The indoor inhalation pathway. *Environ. Sci. Technol.* 21, 1194-1201.
- 9 Prichard, H.M. and Gesell, T.F. (1981) An estimate of population exposures due to radon in public water supplies in the air of Houston, Texas. *Health Phys.* 41,599-606.
- 10 Hess, C.T., Weiffenbach, C.V. and Norton, S.A. (1982) Variations of airborne and waterborne Rn-222 in houses in Maine. *Environ. Int.* 8, 59-66.
- 11 International Commission on Radiological Protection (ICRP) (1975) Report of the Task Group on Reference Man. ICRP Publication 23, Pergamon Press, Oxford.
- 12 Canadian Environmental Health Directorate (1981) Tap Water Consumption in Canada. Ministry of National Health and Welfare, Publication No. 82EHD80.
- 13 MacKay, D. and Paterson, S. (1983) Fugacity models of indoor exposure to volatile chemicals. *Chemosphere* 12, 143-154.
- 14 Bond, R.G., Straub, C.P. and Prober, R. (1973) Handbook of Environmental Control, Vol. III: Water Supply and Treatment. CRC Press, Cleveland, OH, p.155.
- 15 Siegrist, R.L. (1983) Minimum-flow plumbing fixtures. *Am. Water Works Assoc. J.* 75, 342-247.
- 16 Lyman, W.J., Reehl, W.F. and Rosenblatt, D.H. (1982) Handbook of Chemical Property Estimation Methods. McGraw-Hill Book Company, New York, NY.
- 17 Verschueren, K. (1983) Handbook of Environmental Data on Organic Chemicals. 2nd ed., Van Nostrand Reinhold Company, New York, NY.
- 18 James, I.R. and Knuiman, M.W. (1987) An application of Bayes methodology to the analysis of diary records from a water use study. *J. Am. Stat. Assoc.* 82, 705-711.
- 19 Stewart, R.D. and Dodd, H.C. (1964) Absorption of carbon tetrachloride, trichloroethylene, tetrachloroethylene, methylene chloride, and 1,1,1-trichloroethane through the human skin. *J. Am. Ind. Hyg. Assoc.* 25, 439-446.
- 20 Riihimaki, V. and Pfaffli, P. (1978) Percutaneous absorption of solvent vapors in man. *Scand. J. Work Environ. Health* 4, 73-85.
- 21 Brown, H.S., Bishop, D.R. and Rowan, C.R. (1984) The role of skin absorption as a route of exposure for volatile organic compounds (VOCs) in drinking water. *Am. J. Pub. Health* 74, 479-484.
- 22 Scheuplein, R.J. and Blank, I.H. (1971) Permeability of the skin. *Physiol. Rev.* 51, 701-747.
- 23 Bronaugh, R.L. (1985) *In vitro* methods for the percutaneous absorption of pesticides. In: R.C. Honeycutt, G. Zweig, and N.N. Ragsdale (Eds.), *Dermal Exposure Related to Pesticide Use: Discussion of Risk Assessment*, ACS Symposium Series 273, American Chemical Society, Washington, DC, pp. 33-41.
- 24 Foster, S.A. and Chrostowski, P.C. (1986) Integrated household exposure model for use of tap water contaminated with volatile organic chemicals. 79th Meeting, Air Pollution Control Association, Minneapolis, MN, Paper 86-12.3.

- 25 U.S. Nuclear Regulatory Commission (U.S. NRC) (1977) Regulatory Guide 1.109: Calculation of Annual Doses to Man from Routine Release of Reactor Effluents for the Purpose of Evaluation Compliance with 10 CFR Part 50, Appendix I, Revision 1, U.S. Nuclear Regulatory Commission, Office of Standards Development, Washington, DC.

# MULTIMEDIA TRANSPORT OF ORGANIC CONTAMINANTS AND EXPOSURE MODELING

David W. Layton and Thomas E. McKone

*Environmental Sciences Division, Lawrence Livermore National Laboratory,*

*P.O. Box 5507, Livermore, CA 94550*

## **SUMMARY**

Human exposures to organic contaminants in the environment are a complex function of human factors, physicochemical properties of the contaminants, and characteristics of the environmental media in which the contaminants reside. One subject of interest in the screening of organic chemicals for the purpose of identifying exposure pathways of potential concern is the relationship between exposures and contaminant properties. To study such relationships, a multimedia environmental model termed GEOTOX is used to predict the equilibrium partitioning and transport of "reference" organic chemicals between compartments representing different media (i.e., soil layers, groundwater, air, biota, etc.) of a contaminated landscape. Reference chemicals, which are added to the surface soil of a landscape, are defined by properties consisting of the Henry's law constant, soil water-soil organic carbon partition coefficient, and bioconcentration factors. The steady-state concentrations of the chemicals in the GEOTOX compartments then are used to estimate lifetime average exposures (in milligrams per kilogram per day) to the contaminants for individuals living in the contaminated landscape. Exposure pathways addressed include ingestion, inhalation, and dermal absorption. Local sensitivity analyses are performed to determine which chemical and landscape properties have the greatest effect on the exposure estimates.

## **INTRODUCTION**

Organic compounds released into the environment will distribute to soils, water, and air where various chemical and biological processes act to degrade them. The distribution of organic substances among the different media depends on their physicochemical properties as well as the characteristics of the landscapes where they are released or deposited. Human exposures to the "resident" contaminants in a landscape can subsequently occur through direct contact with various media (e.g., skin contact with soil) or consumption of contaminated foods. Unfortunately, little is known about the relationships between contaminant and landscape properties and potential exposure pathways to humans. To study these relationships, we use a multimedia model termed GEOTOX [1,2] that simulates the simultaneous transport and transformation of a contaminant among different

environmental media (e.g., groundwater, soils air, etc.). Human exposures to a contaminant are also estimated by GEOTOX for air-, water-, and soil-based pathways.

The GEOTOX model uses the "fugacity" approach described by Mackay and Paterson [3] to define distributions among the physical phases of each environmental compartment. Transfers between compartments consist of mass transfer and advection. Cohen and Ryan [4] have illustrated the use of multimedia models as screening tools for environmental impacts. GEOTOX has been developed to deal explicitly with a multimedia approach to total human exposure.

As a means of exploring the relationships among contaminant properties, landscape characteristics, and exposure, we have defined a series of reference chemicals with widely varying physicochemical properties (i.e., Henry's law constant, bioconcentration factors, and soil-water partitioning) and a landscape with geohydrologic features that are representative of humid areas in the southeastern United States. Multipathway exposures to the reference contaminants in the landscape are estimated for an individual who lives an entire lifetime in the landscape and receives all of his/her food from indigenous sources. In the sections that follow, we describe the primary attributes of the compartmental structure of GEOTOX along with the key transport processes between compartments. We also define the contaminant properties that are of primary interest in our analyses as well as the characteristics of the different exposure pathways. We then examine the results of our simulations of the exposures associated with different contaminants in the landscape.

#### **A COMPARTMENTAL VIEW OF THE ENVIRONMENT**

The environment can be viewed as a series of distinct, but interconnected compartments, consisting of terrestrial, atmospheric, and aquatic components. We use eight homogeneous compartments to represent a typical landscape unit, which is shown in Figure 1. The terrestrial sub-environment includes an upper soil layer that includes the root zone of plants; a lower soil layer that is the unsaturated or vadose zone above an unconfined aquifer or groundwater component of the landscape. The aquatic environment is represented by a surface water source (i.e., pond, lake) that includes a layer of sediments. The atmosphere is divided into a gas phase and a particulate phase.

A compartment is described by its total mass, total volume, solid-phase mass, liquid-phase mass, and gas-phase mass. Mass flows among compartments include solid-phase flows, such as dust suspension or deposition, and liquid-phase flows, such as surface run-off and groundwater recharge. The transport of individual chemical species among compartments occurs by diffusion and advection at the compartment boundaries. As an example, consider the upper soil layer, which contains solids,



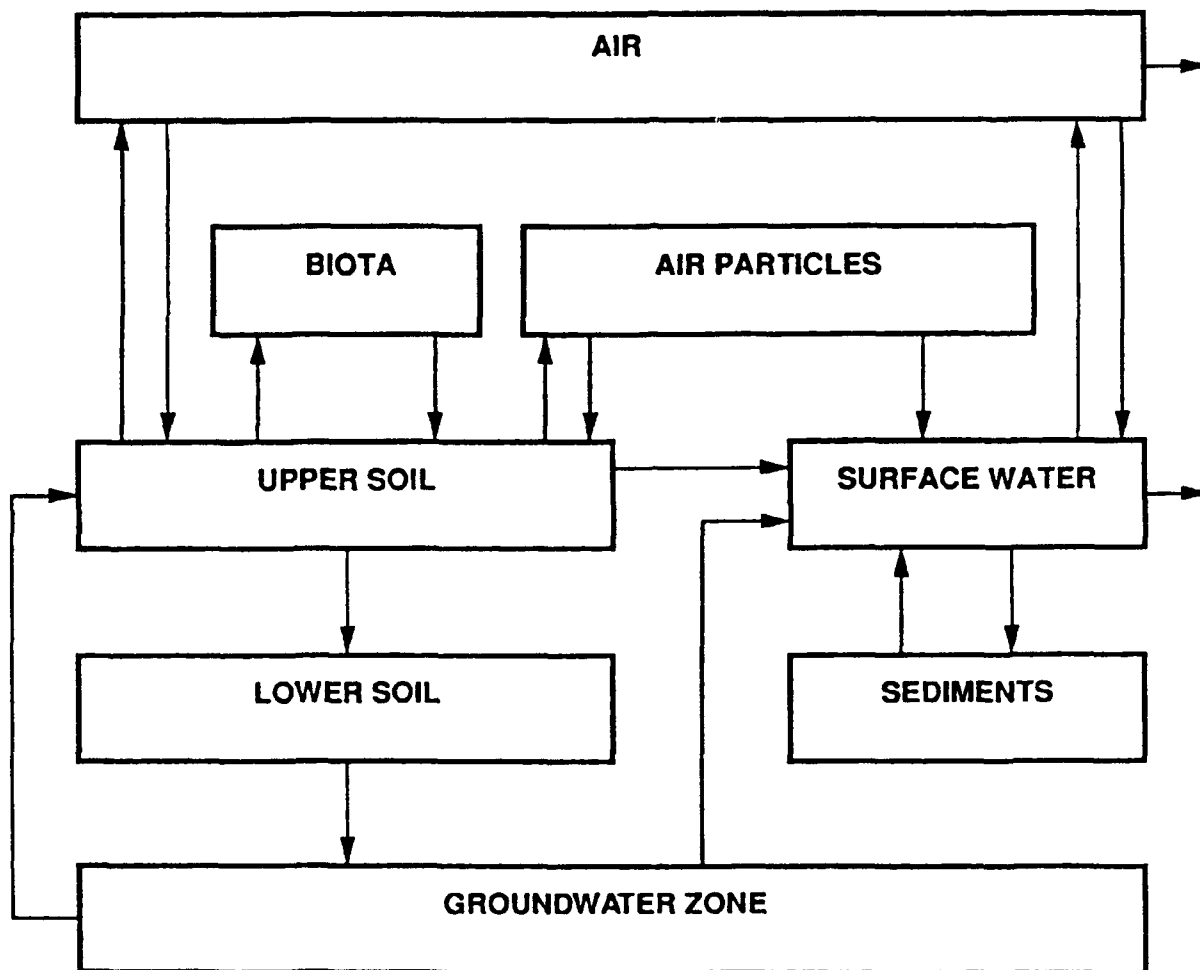


Figure 1. Compartmental Structure of the GEOTOX Multimedia Model.

liquids, and gases. An organic chemical added to the surface soil distributes itself among these three phases such that it achieves chemical and physical equilibrium. Among the potential transport pathways from the upper-soil compartment are liquid advection (surface run-off), solid-phase advection (soil erosion to surface water or dust stirred up and blown about), and diffusion from the the soil-gas phase into the lower atmosphere. Each chemical species is assumed to be in chemical equilibrium among the phases within a single, well-mixed compartment. However, there is no requirement for equilibrium between adjacent compartments. Table 1 lists the pertinent parameters for each of the eight compartments.

**TABLE 1. PARAMETERS THAT DEFINE THE PRIMARY ATTRIBUTES OF THE EIGHT COMPARTMENTS USED IN GEOTOX**

Compartment	Parameter
1. Air (gas)	Height Absolute humidity Precipitation Ambient temperature Yearly average wind speed
2. Air (particles)	Height Dust load Deposition velocity of dust particles Resuspension velocity of soil particles
3. Biomass	Dry-mass inventory Dry-mass production
4. Upper and lower soils	Thickness Bulk density Water content Air content Organic carbon fraction Evapotranspiration (surface soil) Surface runoff (surface soil) Mechanical erosion (surface soil)
5. Groundwater	Water inventory Rock porosity Rock density Irrigation withdrawal Recharge Organic carbon fraction
6. Surface water	Fraction of land surface Average depth Suspended-sediment load Sediment-deposition rate Precipitation Evaporation
7. Sediments	Thickness Bulk density Porosity Sediment resuspension rate Sediment deposition rate Organic carbon fraction

Time-dependent changes in the molar inventory of a contaminant in a compartment are defined by the following mass-balance equation:

$$\frac{dN_i^a}{dt} = \lambda_i^a N_i^a(t) - \sum_{j=1}^m T_{ij}^a N_i^a(t) - T_{io}^a N_i^a(t) + \sum_{j=1}^m T_{ji}^a N_j^a(t) + S_i^a(t), \quad (1)$$

where

$N_i^a$  = molar inventory of species  $a$  in compartment  $i$  at time  $t$ , moles

$\lambda_i^a$  = decay constant for species  $a$  in a compartment  $i$  accounting for radioactive decay, chemical decomposition, etc.,  $y^{-1}$

$T_{ij}^a$  = transfer rate of species  $a$  from compartment  $i$  to compartment  $j$ ,  $y^{-1}$

$T_{io}^a$  = transfer rate of species  $a$  from compartment  $i$  to some external system  $o$ ,  $y^{-1}$

$S_i^a$  = source term for the rate of introduction of species  $a$  into compartment  $i$ , moles/year

$m$  = the number of compartments.

The transfer rates between compartments are a function of the diffusive and advective fluxes between the compartments. The steady-state solution to Equation 1 is obtained by setting the derivatives equal to zero and solving the system of simultaneous equations for a constant source,  $S_i$ . The partitioning of a contaminant between the solid, liquid, and gas phases of a compartment is determined by the soil/sediment partition coefficient,  $K_d$ , and the Henry's law constant,  $H$ , which represents the equilibrium partitioning of a contaminant between air and water (which can be estimated as the ratio of vapor pressure to aqueous solubility). The  $K_d$  value for a neutral organic compound in a particular soil also can be estimated as the product of its organic carbon/water-partition coefficient,  $K_{oc}$ , and the weight fraction of organic carbon in the soil. To estimate transfers of a contaminant to foods, three additional partition coefficients are used in GEOTOX. The plant/soil partition coefficient,  $K_{sp}$ , is the ratio of contaminant concentration in vegetation (dry weight) to concentration in soil. Contaminant transfers from media and feed to milk and meat are estimated with the partition coefficient,  $K_{fd}$ , which is the ratio of contaminant concentration in animal fat to contaminant concentration in animal diet. The third partition coefficient is the bioconcentration factor for fish,  $K_{fw}$ . This factor is calculated as the ratio of the contaminant concentration in fish at steady state to the contaminant concentration in water.

## REFERENCE CHEMICALS

For the purpose of illustrating the effect of the physicochemical properties of a contaminant on exposure estimates, we have chosen low and high values for  $H$  and  $K_{oc}$ , and the bioconcentration

factors,  $K_{fd}$  and  $K_{fw}$ , denoted collectively as B. Table 2 presents the values chosen for the different properties. A reference chemical is defined by a unique combination of property values. As an example, H(h)K(h)B(h) represents a substance with high values for the properties; low values are designated by an "l." There are eight unique combinations of the properties, each of which defines a different reference chemical (the reference chemical combinations are denoted HIKlBl, HlKlBl, HlKlBh, HlKlBh, HllKlBl, HhKlBl, HhKlBh, and HhKlBh). All of the reference chemicals have a gram-molecular weight of 100 and diffusion constants for air and water of  $5 \times 10^{-6}$  and  $5 \times 10^{-10}$  m/s [5], respectively. Because little is known about the potential range of  $K_{sp}$  values for organic chemicals, we simply assume that the concentration of a contaminant in plant biomass is equal to the concentration of the contaminant in soil water.

**TABLE 2. PRIMARY PROPERTIES SELECTED TO REPRESENT REFERENCE CONTAMINANTS<sup>a</sup>**

Parameter	Parameter value	
	Low	High
Henry's law constant, torr-L-mol (H)	$10^{-3}$	$10^3$
$K_{oc}$ (K)	10	$10^3$
Bioconcentration factors (B)		
$K_{fw}$	10	$10^3$
$K_{fd}$	$10^{-2}$	1

<sup>a</sup> A reference chemical is defined by a unique combination of properties. For example, H(h)K(h)B(h) stands for a reference chemical with higher values for each of the three properties.

## REFERENCE LANDSCAPE

The landscape for which we have chosen to simulate the equilibrium partitioning and transport of the reference chemicals among the eight compartments shown in Figure 1 is indicative of the southeastern United States, a humid region with annual rainfall of about 100 cm. The salient characteristics of the atmospheric compartments are a mixing height of 1000 m and an annual average wind speed of about 4 m/s. The dust load of the air (particles) compartment is  $100 \mu\text{g}/\text{m}^3$ , and the average deposition velocity of the particles is 330 m/day. The upper and lower soil layers are 0.25 and 2 m thick, respectively, with organic carbon contents of 2 and 0.1 wt%. The surface soil layer supports an annual average standing biomass (dry) of  $3 \times 10^7$  kg/km<sup>2</sup>. Surface runoff amounts to 35 cm/year and evapotranspiration is 60 cm/year. Erosion of surface soil is estimated at  $3 \times 10^5$  kg/km<sup>2</sup>/year. The groundwater compartment, with a thickness of 46 m has a porosity of 0.1 and a density of 2.3 kg/L. Recharge to the aquifer is 5 cm/year and irrigation withdrawals are the equivalent of 2 cm/year. The organic carbon content of the aquifer is 0.01 wt%. The area of the surface-water compartment is 2% of the total land surface and the underlying sediments are 0.05 m

thick. Estimates of all the landscape parameters are summarized in McKone and Layton [1] and the derivation of the parameter estimates are contained in Layton et al. [2].

## EXPOSURE PATHWAYS

For the purposes of our analysis we assume that a lifelong resident of the reference landscape receives all of her/his food and water from the landscape. The landscape has a surface area of 1 km<sup>2</sup>, and we further assume that each reference chemical is continuously added to the surface-soil layer. There are seven pathways by which an individual can be exposed to a reference chemical: (1) inhalation, (2) water consumption, (3) fruit and vegetable ingestion, (4) meat and dairy-food ingestion, (5) fish ingestion, (6) soil ingestion, and (7) dermal absorption of contaminants adsorbed to soil particles. In order to estimate lifetime exposure to a reference chemical via these pathways, we calculate a time-weighted exposure (in milligrams per kilogram per day) based on childhood (0 to 10 year) and adult (10 to 70 year) exposures. Table 3 lists the appropriate physiologic characteristics of the two age groups. Another assumption related to the exposure scenario is that half the drinking water comes from the surface-water compartment and half comes from groundwater. Because of a general lack of data on the biotransfer of organic compounds from contaminated soils to crops and meat, we have adopted a simplified approach for calculating exposures to contaminants via the consumption of fruits/vegetables and meat/dairy products [1,2]. We calculate exposures via the fruit/vegetable pathway as the product of the contaminant concentration in edible biomass and the daily intake of fruits, vegetables, and grains (see Table 3 for daily intakes). For the meat- and dairy-food-based pathways, exposures are computed as the product of the ingestion of milk or beef fat and the concentration of a contaminant in fat. The contaminant concentration in fat is calculated by multiplying the weighted-average concentration in contaminated media and feed by the bioconcentration factor,  $K_{fd}$ . The concentration of a contaminant in fish is calculated as the product of the contaminant concentration in surface water and  $K_{fw}$ . Exposures to contaminated soils occur via direct ingestion and dermal absorption. Daily intakes are calculated as the product of contaminant concentration in soil and soil intakes by each exposure route.

## DISTRIBUTION OF REFERENCE CHEMICALS AMONG THE EIGHT ENVIRONMENTAL COMPARTMENTS

To examine the effect of chemical properties on the compartmental distributions of the chemicals, we used GEOTOX to calculate the percentage breakdown of the total mass of each reference chemical among the eight compartments under steady-state conditions (calculations were based on the annual addition of 1 g/mol of each chemical to the surface soil of the 1 km<sup>2</sup> landscape, no subsequent chemical or biological degradation, and transport out of the landscape via advection from the surface water and air compartments). The primary parameters influencing the compartmental distributions were  $H$  and  $K_d$ . The bioconcentration factors did not significantly affect

**TABLE 3. PHYSIOLOGIC, FOOD, AND SOIL INTAKE PARAMETERS<sup>a</sup> FOR A CHILD AND ADULT**

Parameter	Units	Child	Adult
Age	year	0-10	10-70
Weight	kg	17	70
Surface area of skin	m <sup>2</sup>	0.79	1.7
Inhalation rate	m <sup>3</sup> /day	10	22
Water intake	L/d	0.7	2
Intake of fruits and vegetables <sup>b</sup>	kg (fresh)/day	0.6	0.5
Intake of milk and dairy products	kg (fresh)/day	0.5	0.3
Intake of meat and poultry	kg (fresh)/day	0.1	0.3
Intake of fish	kg (fresh)/day	0.002	0.0065
Soil ingestion	mg/day	100	58
Dermal absorption of soil	mg/day	8	5

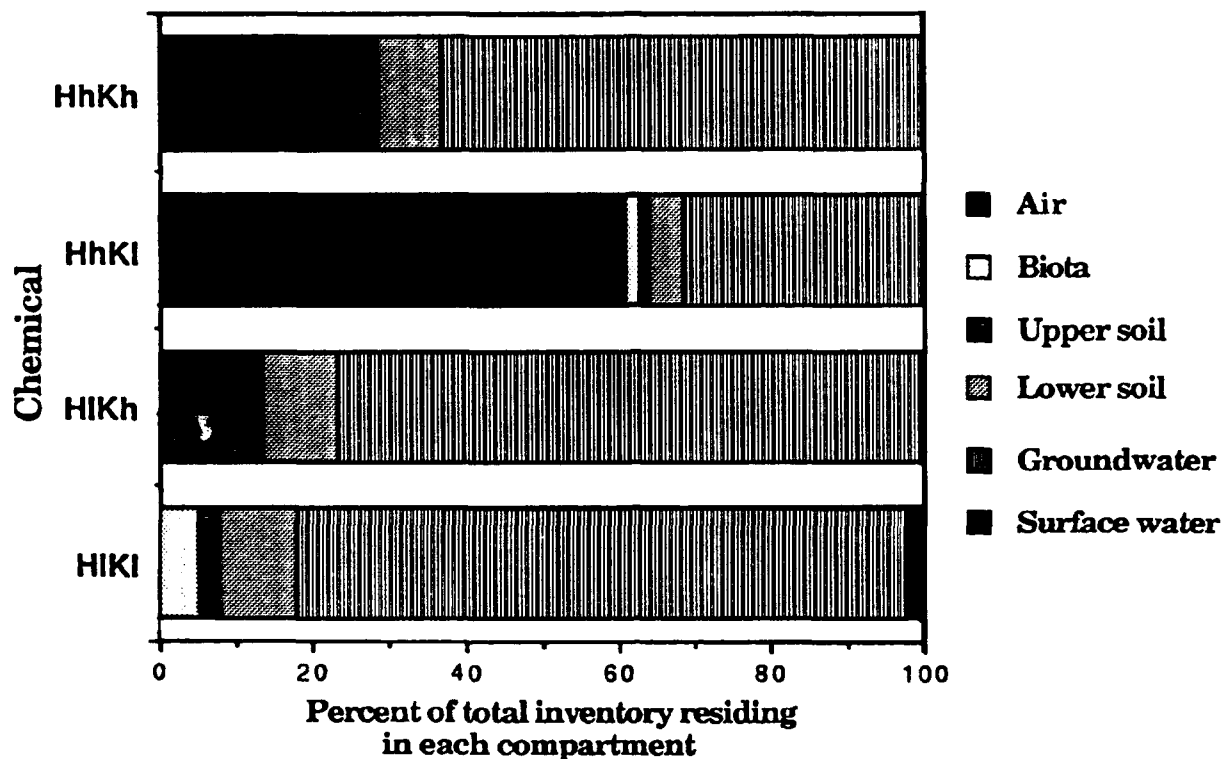
<sup>a</sup> Based on data in Snyder [6], US NRC [7], Hawley [8], and Lepow et al. [9]. Adapted from McKone and Layton [1].

<sup>b</sup> For vegetation, the ratio of fresh mass to dry mass was assumed to be approximately 5.

the distribution of the reference chemicals among the compartments. In Figure 2 we show graphically the distributions of four reference chemicals (expressed as percents of the total mass in the landscape) among the eight landscape compartments. The four chemicals represent four different combinations of the low and high values of  $H$  and  $K_d$ . Significant percentages of the reference chemicals with the high Henry's law constants reside in the atmospheric (gas) compartment; however, with a low value of that parameter, essentially none of the chemicals reside in the atmosphere at steady-state conditions. As the value of  $K_d$  increases for both the low and high Henry's law compounds, more of the compounds reside in the subsurface compartments (i.e., the two soil layers and groundwater) due to the greater sorption to solids contained in those compartments.

#### EXPOSURES TO REFERENCE CHEMICALS

We predicted lifetime average exposures to each of the reference chemicals and found that the four compounds with the high values for the Henry's law constant (i.e., HhKIBI, HhKhBI, HhKIBh, and HhKhBh) resulted in exposures that were dominated by inhalation. In fact, the inhalation pathway ranged from 93 to 98% of the lifetime exposure. The next important pathway for those chemicals was meat/dairy-food ingestion, which amounted to no more than 4% of total exposure. The low Henry's law compounds, in contrast, produced annual average exposures that were about a factor of 40 higher than the low Henry's law compounds. The main reason for the difference was that the



**Figure 2. Percentage Breakdowns of the Steady-State Mass Inventories of Four Reference Chemicals Among Six of the Major Components.**

residence time of the volatile chemicals in the atmospheric (gas) compartment was quite short because of advective losses and, therefore, the ambient concentration did not reach levels that produced elevated exposures. The principal exposure pathways for the low Henry's law compounds are shown in Figure 3. When the bioconcentration factors were low, ingestion of water and grains/vegetables (i.e., denoted as biota) were the dominant pathways, but when the bioconcentration factors were high, fish and meat/dairy-food ingestion became important. The ingestion of contaminated groundwater from the landscape, however, may be unimportant for short-term inputs, as opposed to steady-state inputs, because of the long residence times associated with the groundwater compartment. Dermal absorption and soil ingestion were never significant pathways for any of the eight reference chemicals considered. Nevertheless, we note that we are simulating an idealized exposure scenario (i.e., an individual receives all food, air, and water from the contaminated landscape) and, therefore, under other exposure scenarios skin absorption and soil ingestion could actually constitute the primary or sole exposure pathways to a contaminant at a given location.

To study further the relationship between the Henry's law constant and the total exposure to a compound, we varied this parameter over six orders of magnitude. At values less than 0.1 torr-L/mol,

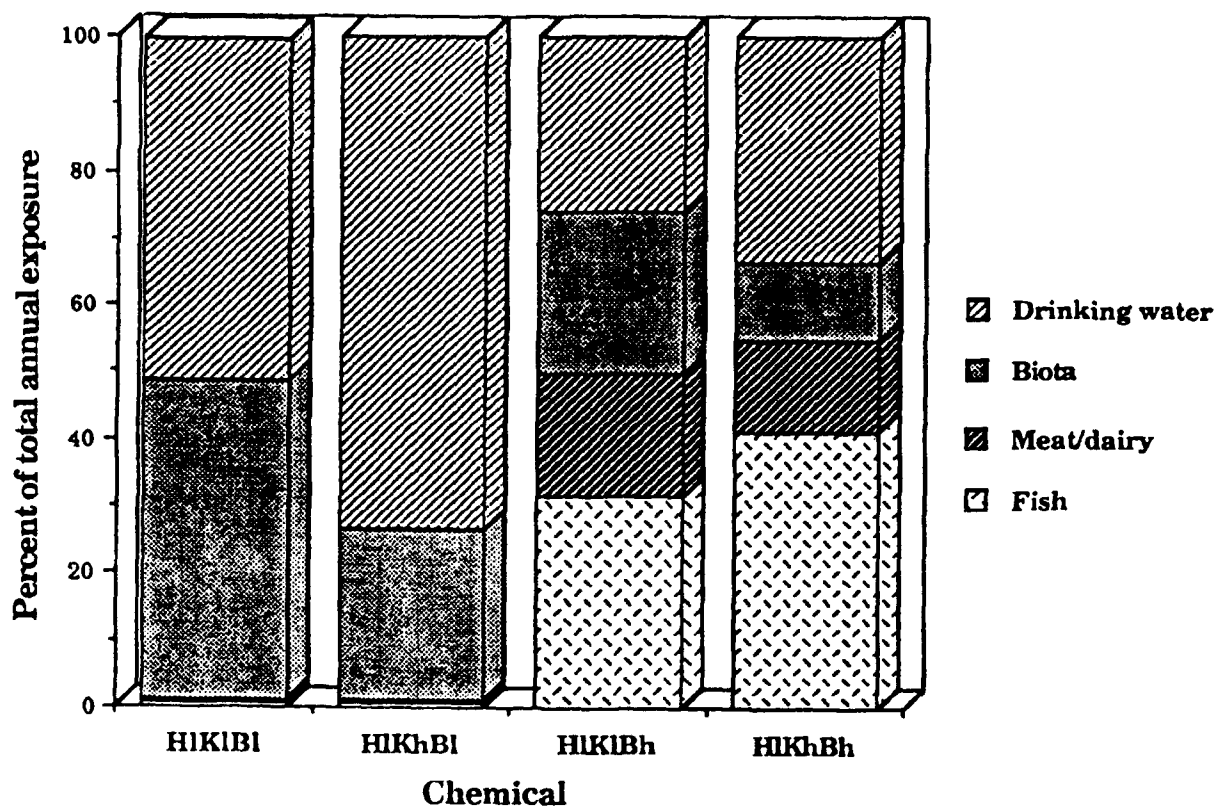
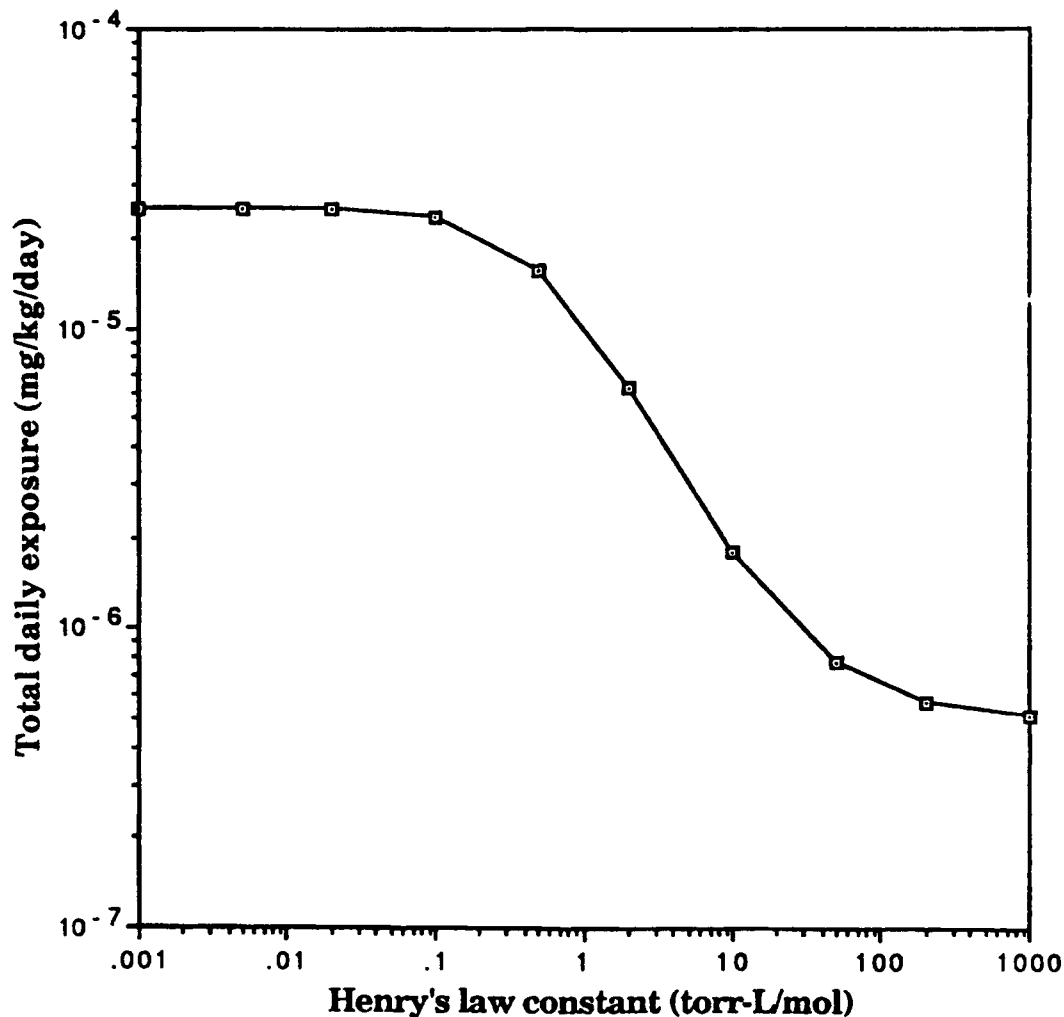


Figure 3. Major Components of the Daily Exposures to Four Reference Chemicals Added to the GEOTOX Landscape.

there were essentially no changes in the calculated exposures because the concentrations of the various contaminants in soils and water were not significantly changing and hence the associated noninhalational exposures were also unchanging (see Figure 4). We also completed a differential sensitivity analysis by sequentially reducing each variable by 1% and determining the percent change in total exposures. For a compound with a low Henry's law constant (i.e., HIKIBl), the most important parameters were those that directly affected the hydrologic balance of the landscape and chemical partitioning between soil and soil water. A 1% decrease in rainfall increased total exposure by 1.9% and similar decreases in evapotranspiration, runoff, organic carbon content of the surface soil layer, and  $K_{oc}$  changed total exposures by -1.12, +0.26, +0.30, and +0.30%, respectively. For a high Henry's law compound (i.e., HhKhBh), exposures were most sensitive to changes in parameters affecting the atmospheric concentration of a chemical. The height of the atmospheric compartment and average wind speed had the greatest effect on total exposure (i.e., both increased exposure by



+ 1.01%), followed by rainfall (-0.04%), evapotranspiration (+ 0.02%), and the Henry's law constant (+ 0.02%).



**Figure 4.** Total Daily Exposures Resulting from the Steady-State Release of Chemicals with Different Henry's Law Constants, but with Fixed Values of  $K_{OC}$  (100),  $K_{fw}$  (1000), and  $K_{fd}$  (1). Releases are to the surface-soil layer.

### CONCLUSIONS

We have used the GEOTOX multimedia transport model to investigate how reference chemicals distribute in a humid landscape consisting of eight compartments. A key parameter affecting the compartmental distributions of the reference chemicals continuously added to surface soil is the Henry's law constant,  $H$ . With low values of this parameter ( $\sim 10^{-3}$  torr-L/mol), chemicals distributed primarily to groundwater and soils. When the soil water/soil organic carbon partition coefficient,  $K_{oc}$ , was raised from low (10) to high ( $10^3$ ) values, the amount of reference chemical sequestered in soils increased, which meant that smaller amounts of each chemical were available for

transport to the atmosphere or surface water. Changes in H also had an important effect on the predicted exposures. As H decreased, total exposures increased, with ingestion exposures dominating total exposures at low values of H. Skin absorption of chemicals adsorbed to soils and ingestion of contaminated soil were never important exposure pathways in our idealized scenario of exposures to reference chemicals in the landscape. One important data gap that stands out is the absence of data on plant-uptake factors for organic compounds. Additional studies are needed to quantify these uptake factors for different food-chain crops and chemicals with varying physicochemical properties.

#### ACKNOWLEDGMENTS

This work was performed under the auspices of the U.S. Department of Energy by the Lawrence Livermore National Laboratory under Contract No. W-7405-Eng-48.

#### REFERENCES

- 1 McKone, T.E. and Layton, D.W. (1986) Screening the potential risks of toxic substances using a multimedia compartment model: Estimation of human exposure. *Reg. Toxicol. Pharmacol.* 6, 359-380.
- 2 Layton, D.W., McKone, T.E., Hall, C.H., Nelson, M.A. and Ricker, Y.E. (1986) Demilitarization of conventional ordinance: Priorities for data base assessments of environmental contaminants, UCRL-15902, Lawrence Livermore National Laboratory, Livermore, CA.
- 3 Mackay, D.M. and Paterson, S. (1982) Fugacity revisited. *Environ. Sci. Technol.* 16, 654.
- 4 Cohen, Y. and Ryan, P.A. (1985) Multimedia modeling of environmental transport: Trichlorethylene test case. *Environ. Sci. Technol.* 19, 412-417.
- 5 Jury, W.A., Spencer, W.F. and Farmer, W.J. (1983) Behavior assessment model for trace organics in soil: I. Model description. *J. Environ. Qual.* 12, 558-564.
- 6 Snyder, W.S. (1975) Report of the task group on reference man, Report 23, International Commission on Radiological Protection, Pergamon Press, New York, pp. 335-360.
- 7 U.S. Nuclear Regulatory Commission (US NRC) (1977) Regulatory guide 1.109, calculation of annual doses to man from routine releases of reactor effluents for the purpose of evaluating compliance with 10 CFR Part 50, Appendix I. U.S. Nuclear Regulatory Commission, Washington, DC.
- 8 Hawley, J. (1985) Assessment of health risk from contaminated soils. *Risk Anal.* 5, 289-302.
- 9 Lepow, M.L., Bruckman, L., Rubino, R.A., Markowitz, S., Gillette, M. and Kapish, J. (1975) Investigations into sources of lead in the environment of urban children. *Environ. Res.* 10, 415-426.

## **RADON EXPOSURE ESTIMATES**

Bruce O. Stuart

*Health Effects Research, Arthur D. Little, Inc., 30 Memorial Drive,  
Cambridge, MA 02142*

### **SUMMARY**

Chronic inhalation of radon and its alpha-emitting progeny has long been identified with increased incidence of respiratory tract carcinoma in uranium miners of the Colorado Plateau and in Europe. This disease has been regarded as an occupational hazard from the sixteenth century until the mid-1970s, with exposure (and subsequent risk estimates) measured in units of Working Level Months. However, since the reporting during the last several years of elevated radon levels in homes in Pennsylvania, New Jersey, and several New England states, attention has centered on continuous exposure to families and to individuals of all ages and degrees of susceptibility to carcinogenic risk from this ubiquitous radioactive air contaminant. This paper addresses current estimates of risk to the members of the general population and the validity of recently promulgated action levels.

### **INTRODUCTION**

Agricola in 1597 reported lethal pulmonary diseases among the metal miners of Schneeberg in Saxony and Joachimstal in Czechoslovakia [1], but only in the early decades of the Twentieth century has the disease known as "bergkrankheit" (mountain sickness) been diagnosed as pulmonary carcinoma. In the mid-1950s hard rock miners in the United States began the mining of pitchblend and carnotite uranium-bearing ores on the Colorado Plateau, which resulted within 15 to 30 years in six times the incidence of bronchogenic carcinoma in these men compared to men of the same age in other occupations. Epidemiological studies of these respiratory tract cancers among the uranium miners of Europe and in the United States have demonstrated increasing incidences of respiratory tract cancer with increasing total levels of exposure to radon and radon daughters [2]. In uranium mine atmospheres of underground mines in all areas, the radon daughters that arise following the decay of the parent radon are rapidly attached to mine aerosols that are generated in ore handling operations or to very small diesel smoke exhaust aggregates that have been prevalent in the American uranium mines since the early 1950s [3].

During the last decade, international concern has centered upon radon with radon daughters as indoor air pollutants that concentrate in nearly airtight homes and office buildings resulting from efforts directed toward energy conservation [4]. These energy-efficient homes cause exposure to all segments of the population in which much lower air concentrations of radon daughters may be inhaled during life-span exposures (i.e., at much lower dose rates than those that have occurred in

uranium mining populations). In addition, the low dust concentrations in such buildings with very low air changeover rates result in greatly increased fractions of radon daughters that are unattached to carrier aerosols, causing proportionately higher radiological doses in the basal cell epithelium of the conducting airways of the lungs [5,6]. Measurements of air concentrations in Colorado Plateau uranium mines consistently show less than 2% unattached radon daughters, but in regions of quiet air such as in private homes, levels become an order of magnitude higher; 81% of the attached RaA may become unattached upon decay [7]. During the years 1940 to 1988, many models have been developed to calculate the radiation dose to the lungs as a whole or to selected regions of the respiratory tract. Dose conversion factors of rad/WLM\* show considerable increases above unity as the unattached fraction of radon daughters increases [8].

### STUDIES OF RADON DAUGHTER CARCINOGENESIS IN EXPERIMENTAL ANIMALS

In order to define the role of attachment of radon daughters to aerosols and the incidence and site of radon-daughter-induced respiratory carcinoma, a series of experimental studies were conducted using specific pathogen-free Wistar rats [9]. Studies reported in 1977 used groups of 32 rats that received inhalation exposure 84 hours per week to 900 WL radon daughters attached to 15 mg/m<sup>3</sup> carnotite uranium ore dust. Exposures lasted for 150 days and the animals then were held for life-span carcinogenesis studies. These animals showed 60% incidence of squamous carcinoma or adenocarcinoma in the periphery of the respiratory tract following these prolonged inhalation exposures to radon daughters that were 98 to 95% attached to uranium ore dust aerosols, but the animals showed no tumors of the nasal pharynx. In marked contrast, matched groups of rodents that received exposure to radon daughters with only room air aerosols (from 10 to 25% unattached, as likely to occur in private homes) displayed less than 6% squamous carcinoma in the peripheral lung, but 100% nasal squamous metaplasia and several cases of squamous carcinoma in the nasal pharynx, plus 22% squamous metaplasia in the major conducting airways such as the bronchi and first generations of secondary bronchi [9]. Recent studies in the same laboratory involved rats exposed to several concentrations of radon daughters attached to uranium ore dust, designed to determine the effect of exposure rate and unattached fraction of radon daughters on the nature and incidence of pulmonary carcinoma [10]. Groups of 32 or 48 male, specific pathogen-free, Wistar rats received inhalation exposures to radon daughters in groups having unattached percentages of 1.6 and 10, the latter representing exposure conditions that might occur in minimally ventilated dwellings. Pulmonary neoplasms included epidermoid carcinoma, adenocarcinoma, adenosquamous carcinoma, mesothelioma, and adenoma. Exposure regimes included background level, 250, 500, and 1000 WL

---

\* WLM refers to Working Level Month; that is, 170 h in an atmosphere of one working level. One working level (WL) is defined as  $1.3 \times 10^5$  Mev of potential alpha energy from radon daughters per liter of air. These daughters, decay products or progeny of <sup>222</sup>Rn, are <sup>218</sup>Po, <sup>214</sup>Pb, <sup>214</sup>Bi, and <sup>214</sup>Po; both <sup>218</sup>Po and <sup>214</sup>Po are alpha emitters that deliver their dose to the respiratory epithelium.

with total exposures of 640 or 2560 WLM. Percentages of lung tumors resulting from these exposures ranged from none in the case of animals receiving background exposures to laboratory air to 47% in those animals at the lower dose rate; that is, 500 WL with the total received exposure of 2560 WLM. Pathological evaluation resulting from the dose rate exposure study indicated an increase in the risk of pulmonary lung tumors as the exposure rate *decreased*. The studies also showed that the risk of primary lung tumors significantly increases with increased radon daughter unattachment fraction. These results of animal exposures concur with modeling predictions of increasing dose to the bronchial epithelium. Prevalence of nasal pharyngeal squamous metaplasia and carcinoma increased with the increase in RaA (first radon daughter) unattachment fraction.

#### **COMPARISON OF HUMAN EPIDEMIOLOGICAL STUDIES AND EXPERIMENTAL ANIMAL STUDIES**

Epidemiological studies of the incidence of bronchiogenic and other respiratory tract carcinoma among uranium miners in the Colorado Plateau, as well as in several European uranium mining studies, show considerable consistency in the relationship of the risk of bronchial carcinoma *per WLM* [8]. Studies using human volunteers that inhaled significant concentrations of radon daughters attached to uranium mine aerosols in the Colorado Plateau underground mines showed that 90 to 100% attached radon daughters are deposited in the regions of bronchi and subsegmental bronchi [11]. However, because of the efficient deposition of unattached RaA in the trachea and major bronchi, the dose to bronchial epithelium from unattached RaA can be greater than three times that of unattached daughters per unit concentration in the atmosphere. Values for the dose conversion factor of rad/WLM in this region of the respiratory tract are 0.5 for underground miners. Analyses of exposures of individuals in the general population indicate values of 0.7 rad/WLM for men, 0.6 for women, 1.2 for children, and 0.6 for infants [8]. The unit WLM is defined only in terms of potential alpha energy from radon daughters per liter of air. There can be very significant changes in the magnitude of this dose with factors up to twofold higher due to differing characteristics of inhaled atmospheres. These significant differences are not accounted for when using WLM alone as a unit of exposure.

It has been found that animal studies that are conducted to determine the relationship between inhaled radon daughters and respiratory tract carcinogenesis have supported the causal relationships suggested in human epidemiological studies. Tumor production at very high exposures (greater than 1000 WLM) and high exposure *rate* (500 and 1000 WL) was found to be much lower than at moderate exposures (250 WL). This has been demonstrated in rodents (hamsters and rats) and in man. In mining populations, lowest lung cancer rates per unit exposure have been found in the United States uranium miners and in the high exposure group of Canadian fluorspar miners. Prolonged exposures at low dose rates appear to be more productive of lung cancer, as seen in studies of rats conducted in the United States and in France [10,12], where the percentage of tumors *per*

WLM was highest at lowest doses and low-dose rates. The highest risk coefficient of primary carcinoma occurred for persons exposed later in life ( $50 \times 10^{-6}$  lung cancers per year per WLM) compared to an average risk coefficient for all age groups of  $10 \times 10^{-6}$  lung cancers per year per person per WLM.

Predictions of dosimetric models [3,8] are supported by studies in several rodent species. Lung cancers found in studies with hamsters and rats occurred in more distal regions of the conducting airways or in the gas exchange regions which received the highest dose of 0.5 rad/WLM [8]. Human carcinomas generally are found in the large conducting airways of the bronchial tree with adsorbed dose calculations showing the basal cells in the fourth generation of segmental bronchi; these sites received the highest dose of adsorbed radon daughters, also at 0.5 rad/WLM. During colder weather or in air conditioned buildings, indoor concentrations of radon and radon daughters will approach equilibrium values obtained from minimal air changes with levels of unattached radon daughters that deliver radiological doses severalfold higher than those from attached radon daughters. Calculations show that 10-year-old children received alpha radiation doses per WLM that are 2.4 times higher than those obtained in underground miners [8]. This indicates a significantly increased hazard of carcinogenic disease risk resulting from lifetime exposures to this segment of the population.

#### **RECENT REPORTS OF ELEVATED RADON AND RADON DAUGHTERS LEVELS IN HOMES IN THE EASTERN UNITED STATES**

In 1984 the focus of attention of carcinogenesis resulting from radon daughter inhalation by humans shifted from the miners of the Colorado Plateau to the discovery of unusually high radon levels in a home built upon a geological formation called the Reading Prong in Pennsylvania. It soon became evident that each state had different problems associated with radon exposure to the general population. While Pennsylvania had about 22,000 homes on its section of the Reading Prong, more than 250,000 homes were located on the New Jersey Reading Prong [13]. The awareness of a perceived or potential problem accelerated rapidly. In June of 1985 there were three firms performing radon testing in New Jersey. By June of 1986 there were more than 70 such firms.

In order to explain the current hysteria concerning radon/radon daughter levels in the home, a further definition of the working levels is necessary. Because it is far simpler to measure radon, the parent, rather than the individual radon daughters, even though the latter contribute 95 to 98% of the dose to the respiratory epithelium, the "Working Level" can be defined according to its original estimate; that is, 100 pCi of radon/L of air, which at 100% equilibrium with its daughters will give, by definition, 1.0 Working Level. In 1984, the National Council on Radiation Protection and Measurement Report 74 recommended an action level of 8 pCi/L environmental exposures, that is, exposures to the general population [8]. Because only 50% of equilibrium is generally assumed for

radon daughters  $^{218}\text{Po}$ ,  $^{214}\text{Pb}$ ,  $^{214}\text{Bi}$ , and  $^{214}\text{Po}$  (i.e., one-half the concentration of the parent  $^{222}\text{Rn}$ ), this corresponds to an equivalent of 0.04 Working Levels.

In 1986 in order to provide a more conservative position, the U.S. Environmental Protection Agency (EPA) issued a citizen's guide to radon recommending 4 pCi/L as an action level [14]. Although this is a recommended level without the status of regulation, it nevertheless has become the index point upon which the homeowner in many states in the East may or may not be able to sell their homes. Using this "recommended action level" studies conducted by the EPA on 22,600 homes in 17 states during the past two winters have been stated to have more than 25% of the houses with hazardous radon levels prompting the Agency to recommend corrective action. A survey conducted by the Connecticut Department of Health Services during 1988 purported that of 3400 homes in 38 communities there were "dangerous" levels in 1 out of 5 homes [15]. In the same citizen's guide, there is equated an exposure level of 4 pCi/L to the same lung cancer risk to those people that smoke half a pack of cigarettes daily or receive 300 chest X-rays annually [14]. In the same publication there is given a further estimate that 5000 to 20,000 lung cancer deaths per year may be attributed to radon exposure in the United States and that owners of "higher radon" homes should give serious thought to remedial ventilation of the basement air to the outside of the house.

#### **VALIDITY OF RECENTLY PROMULGATED RECOMMENDED ACTION LEVELS**

The recommended action level by the EPA is based upon linear extrapolations of high-dose level exposure over 5 to 30 years of a small mining population on the Colorado Plateau [14]. The equating of lung cancer risk from a specified level of radon daughters to a given level of cigarette smoking is particularly difficult in that there is a close synergism between incidence of bronchogenic carcinoma in the uranium miner population and high levels of cigarette smoking by these men. The wide limits of uncertainty found in the lung cancer risk estimate associated with a given total exposure level and the emerging importance of dose rate factors demonstrated by recent animal and epidemiological studies have resulted in risk estimate calculations by agencies within the United States as well as in Canada and Europe, that suggest a much lower risk per WLM or pCi/L exposure level. Thus, the action level recommended by the EPA of 4 pCi/L is low when compared with that recommended by Canada and Finland [16]. It is likely that countries of the European Common Market will follow the example of these two countries. These countries recommend remedial action only if radon levels are at 20 pCi/L. It is estimated that if the millions of homes in the United States that slightly exceed the 4 pCi/L action level were ventilated according to currently recommended methods, the cost would be in the billions of dollars. Nearly an order of magnitude fewer homes would be expected to exceed concentrations of 20 pCi/L, compared to those estimated to have concentrations in excess of 4 pCi/L [13].

It is very difficult to define an adequate control population; that is, those not exposed to radon as it is a ubiquitous air contaminant over the entire surface of this planet arising from natural radioactivity sources, and because one is dealing with a disease that may have a latent-induction period, even at the high-exposure levels encountered by the uranium miners, of 5 to 30 years. Epidemiological studies, although proliferating rapidly in the last few years, will provide only meager data in the near future and will require exacting analysis concerning their experimental design and execution. In two recent epidemiological surveys taken retrospectively there is no evidence of higher lung cancer rates in communities that are reported to be below the EPA recommended action level. Although statewide surveys of homes in New Jersey show radon levels that are seven times higher than those in Texas, New Jersey has the same mean incidence of lung cancer deaths as Texas. In a recent survey of 10 states conducted by the University of Pittsburgh, 39,000 measurements of radon were taken in 415 communities [15]. This survey showed no evidence of a correlation between higher lung cancer rates and high indoor radon concentration. Epidemiological studies conducted to date have not been able to adequately detect small influences on respiratory tract cancer, due to the strong correlation of the disease with cigarette smoking habits [12].

## CONCLUSIONS

In view of these uncertainties and the burden that possible unwarranted mitigation efforts may place upon individual homeowners, it is strongly recommended that nationwide action not be taken until 1991, at which time there will be information from the EPA study conducted on radon levels in living spaces of 5000 homes spanning the United States [17]. In a few years' time there also will be available results from a Yale University study on the health effects of radon measured in 10,000 homes in Connecticut [15]. These data will help to provide an accurate and realistic data base to define the relationship between radon and radon daughter exposures and carcinogenic disease risks to members of the general population.

## REFERENCES

- 1 Diberner, B. (1958) Agricola on metals. In: *De Re Metallica*, by Georgius Agricola, Basel, 1597, translated by Herbert C. Hoover, Burndy Library, Inc., Norwalk, CT.
- 2 Archer, V.E., Wagoner, J.K. and Lundin, F.E. (1973) Lung cancer among uranium miners in the United States. *Health Phys.* 25, 351.
- 3 Nelson, I.C., Parker, H.M., Cross, F.T., Craig, D.K. and Stuart, B.O. (1974) A further appraisal of dosimetry related to uranium mining health hazards. U.S. Public Health Service Report CPE 69-111, National Institute of Occupational Safety and Health, Cincinnati, OH.
- 4 Stranden, E. (1981k) Radon in houses utilizing stone magazines for heat accumulation. *Health Phys.* 41, 29-33.



- 5 Jacobi, W. (1972) Relations between the inhaled potential of  $^{222}\text{Rn}$  and  $^{220}\text{Rn}$  daughters and the absorbed energy in the bronchial and pulmonary region. *Health Phys.* 23, 3.
- 6 James, A.C. (1977) Bronchial deposition of free ions and submicron particles studies in excised lung. In: *Inhaled Particles IV, Proceedings of an International Symposium organized by The British Occupational Hygiene Society, Edinburg, Pergamon Press, Oxford*, pp. 203-219.
- 7 Mercer, T. and Stowe, W.A. (1970) Radioactive aerosols produced by radon in room air. In: W.H. Walton, (Ed.), *Inhaled Particles III, Volume II, Unwin Brox, Ltd., Gresham Press, Old Woking Surrey, England*, p. 839.
- 8 Harley, N.H., Cross, F.T. and Stuart, B.O. (1984) Evaluation of Occupational and Environmental Exposures to Radon and Radon Daughters in the United States. NCRP Report No. 78, National Council on Radiation Protection and Measurements, Washington, DC.
- 9 Stuart, B.O., Palmer, R.F., Filipy, R.E., Dagle, G.E. and McDonald, K.E. (1977) Respiratory tract carcinogenesis in large and small experimental animals following daily inhalation of radon daughters and uranium ore dust. In: *Proceedings of the International Radiation Protection Association, IV International Congress, Paris*, pp. 1337-1340.
- 10 Cross, F.T., Palmer, R.F., Dagle, G.E., Busch, R.H. and Buschbom, R.L. (1984) Influences of radon daughter exposure rate, unattachment fraction, and disequilibrium on occurrence of lung tumors. In: *Radiation Protection Dosimetry Vol. 7, No. 1-4. Nuclear Technology Publishing Co.*, pp. 381-384.
- 11 Palmer, H.E., Perkins, R.W. and Stuart, B.O. (1964) The distribution and deposition of radon daughters attached to dust particles in the respiratory system of humans exposed to uranium mine atmospheres. *Health Phys.* 16, 558.
- 12 Chameaud, J., Perraud, R., Masse, R. and LaFuma, J. (1981) Contribution of animal experimentation to the interpretation of human data. *Proceedings of the International Conference on Radiation Hazards, International Atomic Energy Agency, Vienna, Austria*.
- 13 Nicholls, G.F. and Deieso, D.A. (1987) New Jersey: Involving the commercial sector. *Environmenta*, 29 No. 2, 12-37.
- 14 U.S. Environmental Protection Agency (1986) A Citizen's Guide to Radon. EPA-84-004, Washington, DC.
- 15 Natarajan, K.V. (1988) Radon Gas: A Public Health Crisis or a Non-problem? *Hartford Courant* 011, Hartford, CT., December 9.
- 16 Castren, O. (1987) Density with radon in dwellings: The Finnish experience. In: *Indoor Radon II, APCA Indoor Air Quality Intercommittee Task Force and the Department of National Health and Welfare, Canada, APCA, Pittsburg, PA*, pp. 45-56.
- 17 U.S. Environmental Protection Agency (1986) Interim Indoor Radon and Radon Decay Product Measurement Protocols. EPA 520/1-85-04, Washington, DC.

## ATMOSPHERIC CHEMISTRY OF PROPELLANT VAPORS

Daniel A. Stone

*Engineering and Services Laboratory, Headquarters, Air Force Engineering and Services Center  
Tyndall Air Force Base, FL 32403-6001*

### SUMMARY

Hydrazine (HZ) fuels are used as examples of the relatively rapid chemical processes that may occur when propellants are released into the atmosphere from normal handling or during accidents. The experimental procedures used to study these processes are reviewed along with postulated chemical reaction mechanisms and measured reaction rates and products. Results show that chemical processes that occur on a time scale comparable with meteorological processes must be considered in the development of dispersion models. These models must also account for the potential formation of toxic reaction products.

### INTRODUCTION

The USAF uses a variety of propellants in various weapons systems. These include hydrocarbon fuels used in jet aircraft and cruise missiles, HZ fuels used in missiles and auxiliary power generators, and various "exotic", high-energy fuels used in special applications. The use of these propellants presents a wide-range of potential problems. Many of them, or their individual components, are toxic. All of them have strict ceilings on allowed emission levels. Many present handling and storage problems because of their toxicity or physical properties. Finally, treatment of accidental spills, leaks, or contaminated lots is often difficult and expensive.

To maintain its operational readiness, the USAF must understand not only how to use these fuels safely, but know their toxicity levels and their potential effects on the environment. This type of technical base enables USAF operations to continue within the guidelines and limits required by local, state, and national environmental regulatory agencies.

Many different propellants, or their components, are released into the atmosphere from normal operations and from occasional accidents. USAF personnel must be able to show that normal emissions levels comply with regulatory standards for workplace exposure and atmospheric loading. They also must have the ability to model the dispersion of accidental releases of propellant chemicals as well as understand the expected toxicity of these chemicals on USAF personnel in their working environment.

When a fuel or fuel component undergoes a chemical reaction upon release to the environment (whether in a controlled study or in the open air) on a time scale of a few minutes to a few days, these reactions must be accounted for in any model that is used to predict toxicity or atmospheric dispersion. If reactions occur on a much shorter or longer time scale, they can be either ignored or explicitly accounted for.

The eventual fate of USAF propellants released to the atmosphere (or a laboratory simulation chamber) is determined by both physical and chemical processes. Physical processes are controlled by prevailing meteorological (or experimental) conditions and can be modeled at several different levels of complexity. Chemical processes are controlled by species concentrations and kinetic rate constants. When chemical reactions occur at a rate similar to or less than local meteorological (or experimental) dispersion forces, both chemical and physical processes must be considered to successfully model the concentration of a particular species as a function of time.

This paper, then, is a brief review of several current techniques for determining the atmospheric chemistry of propellant vapors. Hydrazine fuels are used as pertinent examples. In addition, the paper reviews the results of several research groups that have been active in this area including a discussion of reaction rates, products, and mechanisms.

## **EXPERIMENTAL PROCEDURES**

### ***Vapor-Phase Reactions***

***Large Teflon® Film Chamber.*** The experimental techniques used in this type of study are intended to provide an environment that closely simulates the ambient troposphere under either polluted or pristine conditions. This is most readily accomplished by constructing flexible chambers from sheets of FEP Teflon® film ranging in thickness from 0.002 to 0.005 in. which are heat-sealed together.

Pitts and coworkers conducted studies of HZs in an outdoor, 30,000-L chamber of this type [1-3]. These same workers conducted further studies in indoor Teflon® film chambers with volumes of 6400 and 3800 L [4, 5]. Stone and coworkers used a 350-L Teflon® film chamber to characterize the lifetime of HZ under different conditions of oxygen and water vapor concentration [6, 7]. A similar study was conducted by Kilduff and co-workers [7, 8], who used a 6,500-L chamber.

All of these studies used similar apparatus and a similar analytical approach. The apparatus is shown schematically in Figure 1. The chamber was provided with a system for generating ultra-pure air (typically less than 1 ppb hydrocarbons, ozone (O<sub>3</sub>), carbon monoxide (CO), or fluorocarbons) at a dewpoint around -60°F. The flow of air was sufficient to provide a complete exchange of chamber air

in about 10 min. Chamber contents were mixed with a mechanical fan with Teflon<sup>®</sup>-coated blades. The fan motor was mounted external to the chamber and coupled through the wall of the blades. Samples of test chemicals were introduced into the chamber with syringes and transfer bulbs of various sizes. Species detection was accomplished by means of long-path Fourier transform infrared (FT-IR) spectroscopy. The infrared beam from the spectrometer was directed into the chamber where it made multiple reflections from mirrors arranged in a White cell [9] configuration and then passed out of the chamber to a mercury cadmium telluride detector. In some cases the Pimentel [10] modification was used to increase the path length. Using this analytical technique, species concentrations in the parts-per-billion range could be achieved readily.

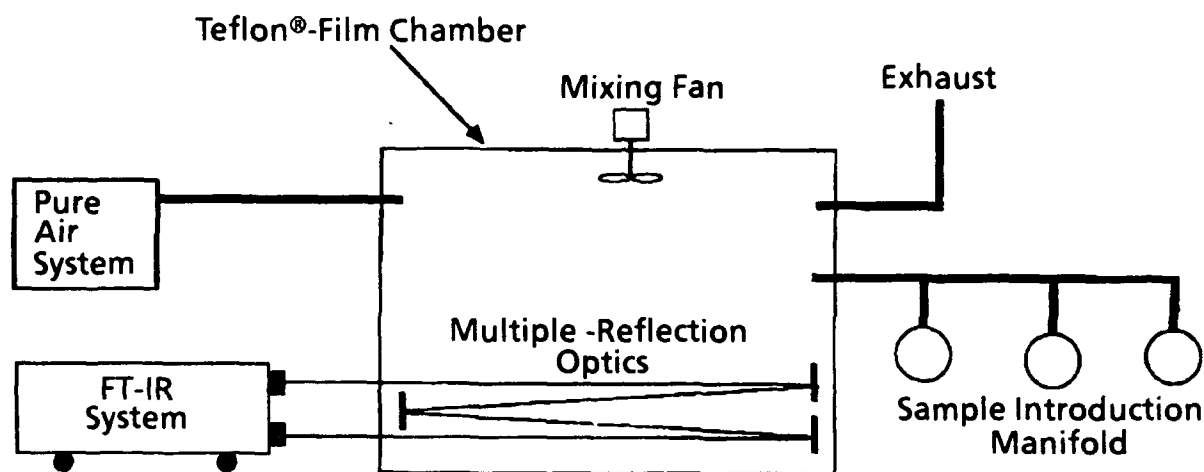


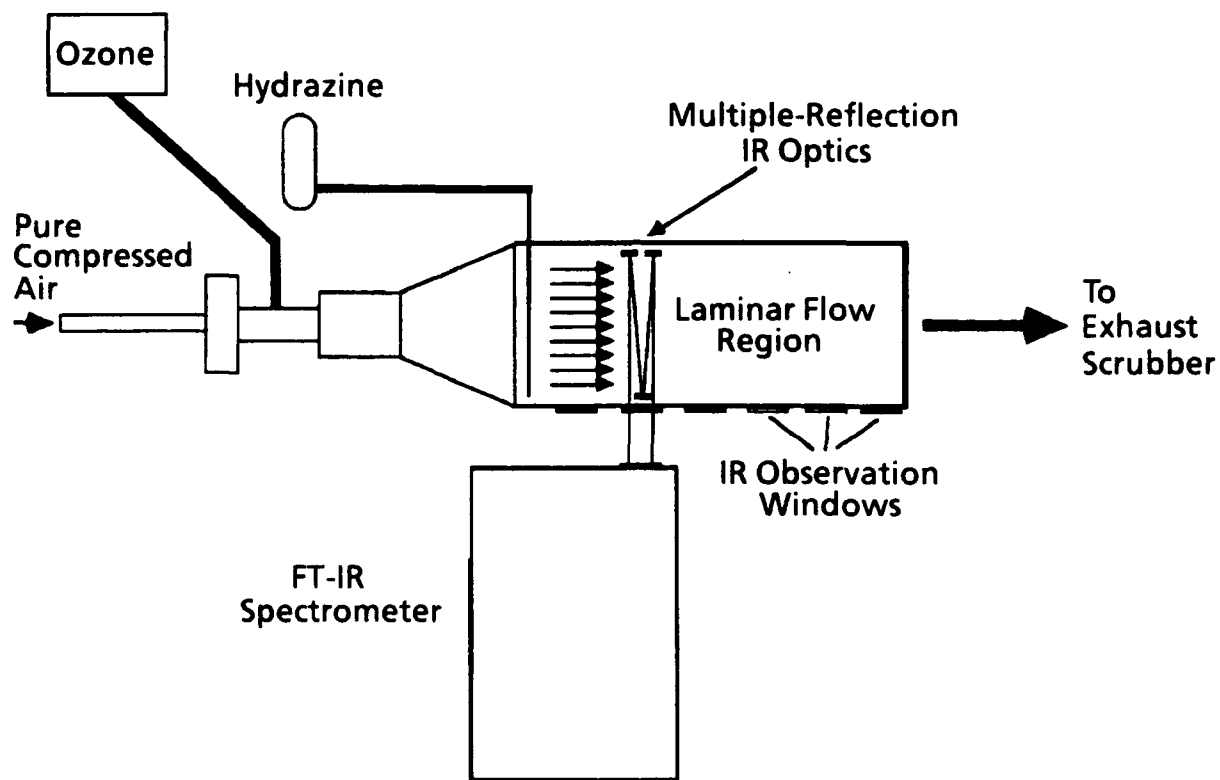
Figure 1. Schematic Diagram of the Teflon<sup>®</sup>-Film Chambers Used in Studies of the Atmospheric Chemistry of Hydrazine Fuels.

**Flow Systems.** Some reactions are too rapid or involve species concentrations too low to be conducted in Teflon<sup>®</sup>-film chambers. Examples include the reactions of HZ fuels with O<sub>3</sub> or hydroxyl radicals. To obtain accurate kinetic parameters for these types of reactions, researchers have employed flow systems.

In the case of O<sub>3</sub>, the half-life of the reaction with HZ is less than 60 s. To follow a reaction on this time scale, a laminar flow reactor was constructed [11]. This apparatus is diagrammed in Figure 2. Pure air entered the apparatus at 5 to 15 standard ft<sup>3</sup>/min. It then proceeded through a flow controller and into the reactor where laminar flow was achieved through a screen-type flow straightener. The resulting linear velocity of the laminar flow ranged from 0 to 20 cm/s.

Hydrazine was admitted to the laminar flow region through special Gortex<sup>®</sup> permeation tubes. Ozone was mixed with the incoming air. The concentrations of HZ, O<sub>3</sub>, and transient species were

monitored with FT-IR spectroscopy. A White cell arrangement again was employed with a path length of about 1.25 m. With this system, HZ concentrations could be followed down to less than 1 ppb. The entire laminar flow system moved on a rigid slide assembly so that steady-state reactions could be viewed at different points in time.

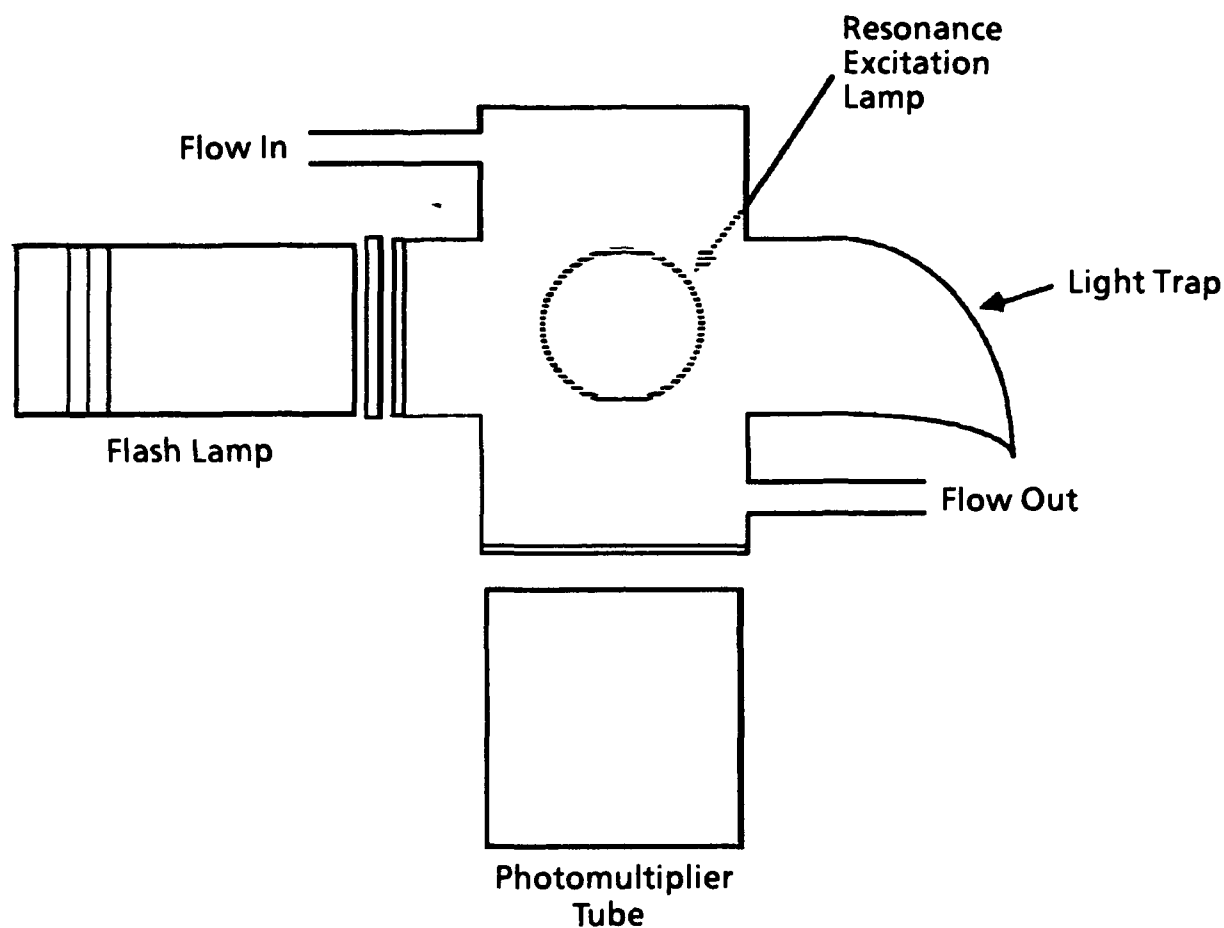


**Figure 2. Schematic Diagram of the Laminar Flow Reactor Used to Study Rapid Reactions of Hydrazine Fuels with Ozone.**

Absolute rate constants for the reaction between HZ fuels and hydroxyl radicals were obtained by using flash photolysis-resonance fluorescence techniques. A schematic diagram of the apparatus is shown in Figure 3. Dilute mixtures of HZ and water vapor were flowed through the reaction cell in argon. Hydroxyl radicals were produced by pulsed vacuum ultraviolet photolysis from the flash lamp. The concentration of hydroxyl radicals as a function of time after the flash was then monitored by exciting the hydroxyl radicals with a resonance lamp and monitored the subsequent fluorescence with single photon counting in conjunction with multichannel scaling.

### **Surface Catalyzed Reactions**

**Small Reaction Chambers.** Several investigators have examined the autooxidation of HZ fuels by observing their behavior in small glass, quartz, or polyethylene reaction vessels (12-19). These



**Figure 3. Schematic Diagram of the Flash Photolysis – Resonance Fluorescence Apparatus Used to Study the Reactions of Hydrazine Fuels with Hydroxyl Radicals.**

studies used gas chromatographic (GC), infrared (IR), or manometric techniques to monitor the course of the reactions. Six of the vessels were generally in the range of 100 to 500 mL, and concentrations of several torr of the different HZ fuel vapors were used. Often, glass wool, rods, or beads were added to determine their effect on reaction rate.

**Large Reaction Chamber.** A number of studies were conducted in larger, glass (20-23) or Teflon®-film reaction chambers [24,25]. The glass chambers used both infrared and GC/MS (mass spectrometry) detection methods. The Teflon®-film chambers used long-path FT-IR detection. In the Teflon®-film chambers, the surfaces to be studied were placed inside the chamber as individual sheets to maximize exposure surface area. Then experimental runs were made to determine any differences in the decay rate and/or products of HZ fuels in air.

**Tubular Reactors.** A novel technique was developed by researchers at the NASA White Sands Test Facility [26] to screen the reactivity of HZ vapors when exposed to various surfaces. The reactors were

constructed of 12.7 cm sections of TFE tubing with an inner diameter of 0.25 cm. The ends of the reactor tubes were plugged with TFE filter membranes. The reactor tubes were used in a conventional GC system with flame ionization detection (except for HZ, where trapping and coulometric titration were used for detection). Reactors contained 1 to 4 g of the material under study in powdered form. Nitrogen or air was used as the carrier gas.

## RESULTS AND DISCUSSION

### *Vapor-Phase Reactions*

**Large Teflon®-Film Chambers.** Tuazon and co-workers [1-5] combined reactive trace atmospheric species, including O<sub>3</sub>, nitrogen dioxide (NO<sub>2</sub>), formaldehyde (CH<sub>2</sub>O), and nitric acid (HNO<sub>3</sub>), with HZ, monomethylhydrazine (MMH), and unsymmetrical dimethylhydrazine (UDMH) in pure air. These experiments were conducted with concentrations in the 1-to-20 ppm range. With O<sub>3</sub>, HZ reacted completely within 15 to 20 min to form hydrogen peroxide (H<sub>2</sub>O<sub>2</sub>) and diazene (N<sub>2</sub>H<sub>2</sub>) with trace amounts of ammonia (NH<sub>3</sub>) and nitrous oxide (N<sub>2</sub>O). By adding a radical trap (*n*-octane) and a radical tracer (hexamethylethane), the important role of hydroxyl radicals in the reaction mechanisms was demonstrated.

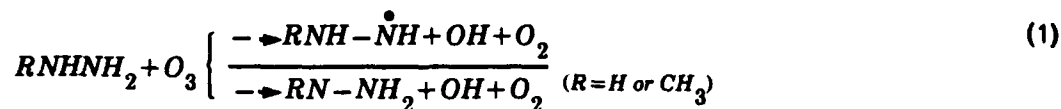
In the case of MMH, the reaction with O<sub>3</sub> produced methylhydroperoxide (CH<sub>3</sub>OOH), methyldiazine (CH<sub>3</sub>NNH), CH<sub>2</sub>O, diazomethane (CH<sub>2</sub>N<sub>2</sub>), and H<sub>2</sub>O<sub>2</sub> with trace amounts of NH<sub>3</sub> and N<sub>2</sub>O. Hydroxyl radicals also were shown to be important in the MMH plus O<sub>3</sub> reaction. In both HZ and MMH reactions with O<sub>3</sub>, the reaction stoichiometry and the products formed depended on the ratio of the initial reactants.

When UDMH and O<sub>3</sub> were combined, the products were *N*-nitrosodimethylamine [(CH<sub>3</sub>)<sub>2</sub>NNO], CH<sub>3</sub>OOH, CH<sub>3</sub>NNH, and H<sub>2</sub>O<sub>2</sub>, with trace amounts of methanol (CH<sub>3</sub>OH), CO, formic acid (HCOOH), nitrous acid (HONO), NO<sub>2</sub>, NH<sub>3</sub>, and CH<sub>2</sub>H<sub>2</sub>. Though hydroxyl radicals also were shown to be important in the UDMH plus O<sub>3</sub> reaction, there was more HONO and much less H<sub>2</sub>O<sub>2</sub> produced than was the case with HZ or MMH.

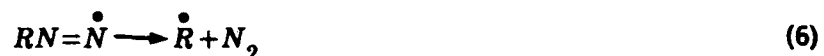
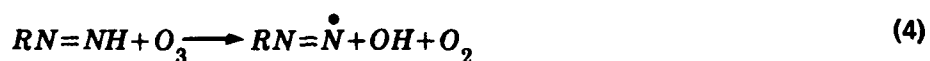
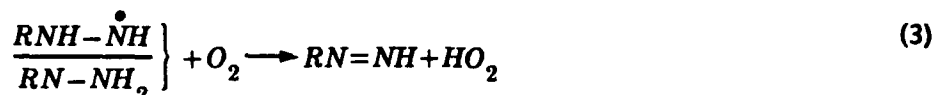
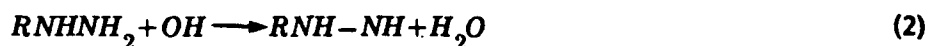
In the case of NO<sub>2</sub>, all three HZs reacted readily, with UDMH having the fastest rate and HZ the slowest. Products of the reaction of HZ and MMH with NO<sub>2</sub> were similar to those of HZ and MMH with O<sub>3</sub>. In addition, hydrazinium nitrates (RNHNH<sub>2</sub>.HNO<sub>3</sub>; R = H, CH<sub>3</sub>) and peroxyxynitric acid (HOONO<sub>2</sub>) were formed. In the case of UDMH plus NO<sub>2</sub>, the products were HONO and tetramethyltetrazine-2[(CH<sub>3</sub>)<sub>2</sub>NNNN(CH<sub>3</sub>)<sub>2</sub>].

Experimental results suggest that the mechanism (5) for the reactions of HZ and MMH with O<sub>3</sub> are free radical processes where OH, hydrazyl (H<sub>2</sub>N-NH or CH<sub>3</sub>NH-NH) radicals, and diazines (HN = NH

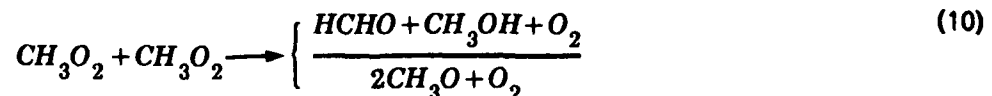
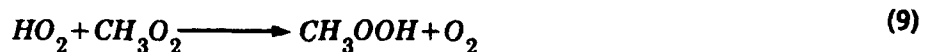
or  $\text{CH}_3\text{N} = \text{NH}$ ) act as the chain carriers. The mechanism is shown explicitly below as an example of the kinds of chemical processes that result from these types of studies. The initiation process is



This is followed by propagation reactions.



Products then are formed in the following reactions.



This mechanism accounts for most of the experimental observations. In the case of  $\text{MMH} + \text{O}_3$ ,  $\text{CH}_2\text{N}_2$  is most likely formed from the reaction of  $\text{O}_3$  with  $\text{CH}_3\text{NNH}$ .



In the case of UDMH plus O<sub>3</sub>, the initial hydrazyl radical that is formed reacts with O<sub>3</sub> eventually giving the observed products. This occurs because the diazine cannot be formed from the removal of one hydrogen atom from each nitrogen as in HZ and MMH.

In the case of the reactions with NO<sub>2</sub>, the mechanism for HZ and MMH involves H-atom abstraction with the formation of HONO and a hydroxyl radical. Subsequent reactions with oxygen form diazines which react further to form products. Details of the mechanism remain somewhat uncertain.

**Flow Systems.** Initial results from the laminar flow reactor [27] show that the injector system functions properly and that infrared spectra can be obtained at six distinct points down the flow field giving reaction rate data on a scale of seconds. The first set of experiments on the rate of the reaction between HZ and O<sub>3</sub> has been completed. With an initial O<sub>3</sub> concentration of 60 ppm and HZ at 19 ppm, the observed reaction rate constant was  $2.5 \times 10^{-16} \text{ cm}^3 \text{ molecule}^{-1} \text{ s}^{-1}$ . The FT-IR spectra were obtained at 4 cm<sup>-1</sup> resolution and should allow identification of reactive intermediates as these studies continue.

In the flash photolysis-response fluorescence studies of Pitts and co-workers [1,2, and 28] absolute rate constants were determined for the reactions of OH radicals with HZ and MMH. The rate constants obtained essentially were independent of temperature over the range of 298 to 424 K. The rate constant values were  $6.1 \times 10^{-11}$  and  $6.5 \times 10^{-11} \text{ cm}^3 \text{ molecule}^{-1} \text{ s}^{-1}$  for HZ and MMH, respectively. Since reaction with the hydroxyl is accepted as the most important atmospheric sink process for chemical species with available hydrogen atoms [28], this rate constant results in an estimated atmospheric half-life of 3 to 6h for these two HZs. Reactions with UDMH were not carried out.

### **Surface-Catalyzed Reactions**

**Small Reaction Vessels.** Early studies of the autooxidation of HZ were conducted by classical gas-phase kinetic techniques involving pressure measurements in small glass reaction vessels [12-13]. The role of surfaces in these reactions was studied by adding glass wool or changing the size of the reaction vessel. Results were limited but demonstrated the importance of surfaces in controlling the rate of the reaction. Later studies [14-18] continued these investigations and also led to the conclusion that surface effects dominated the observed decay of the HZ fuels in the presence of oxygen, at least at torr level concentrations and in vessels with volumes of 2 L or less. Moody [17] developed a detailed reaction mechanism for the air oxidation of HZ which included all possible surface interactions and involved a number of radical intermediates. Urry and co-workers [22] detailed a study of the autooxidation of UDMH and arrived at a mechanism to explain their results.

**Large Reaction Vessels.** In the hope of approaching an experimental situation that would decrease the importance of surface effects, researchers moved to larger reaction vessels. Stone [20]

employed 5-L and 12-L glass vessels, but still used concentrations of several torr of MMH for the study. Results showed a decrease in decay rate proportional to the decrease in surface-to-volume ratio. They also showed that the character of the surface itself was very important. Products of the reaction included methanol, methane, and other unidentified products. Loper [23] studied the autooxidation of UDMH in a 12-L glass vessel and observed the formation of formaldehyde dimethylhydrazone along with other minor products. He suggested a mechanism similar to that given by Urry and co-workers [22]. Bellerby [15,16] also puts forth a detailed mechanism (somewhat different than Loper's) to account for the observed effects of reaction vessel surface on the rates of the autooxidation reaction of HZs at room temperature.

To more nearly simulate atmospheric conditions, Stone used a long, cylindrical glass reaction chamber with a volume of 55 L [20,21]. This chamber utilized long-path infrared species detection and, therefore, concentrations of a few parts-per-million could be used. The observed half-life was essentially the same as that obtained in smaller cells at much higher concentrations, showing that surface effects were still predominant.

An attempt also was made to use large Teflon®-film chambers to study the effects of added surface materials on the vapor-phase air oxidation of HZs. Initial studies by Naik and co-workers [24,25] showed that the addition of certain metals, notably copper and painted aluminum, significantly increased the rate of air oxidation of HZ. Later, Stone and Wiseman refined these results to show that absorption and diffusion play major roles in the decay of HZ in Teflon® film reaction chambers, and also demonstrated that homogeneous oxidation is very slow, if it occurs at all [6,7].

Kilduff and co-workers [8] used a 6500-L Teflon®-film chamber to study the effects of added metal surfaces. Sheets of aluminum, corroded aluminum ( $\text{Al}_2\text{O}_3$ ), hot-dipped galvanized steel, titanium, and stainless steel were studied with HZ;  $\text{Al}_2\text{O}_3$ , galvanized steel, and aluminum were studied with MMH; only  $\text{Al}_2\text{O}_3$  was used with UDMH. Results showed that HZ decayed most quickly in the presence of Al/ $\text{Al}_2\text{O}_3$  (relative rate 74), then titanium (relative rate 46), and was nearly unaffected by galvanized steel (relative rate 2), stainless steel (relative rate 1), or aluminum (relative rate 1). These workers propose a reaction mechanism where the HZ species binds to the metal surface and then reacts with oxygen through a six-membered transition state to yield a diimide and a metal hydroxy hydride. The diimide could react similarly to form nitrogen and other hydroxy hydride. The hydrides then are proposed to undergo reductive elimination reactions to give a reduced metal surface and water. This mechanism is outlined in Figure 4. The authors also propose a mechanism for the formation of  $\text{NH}_3$ , which is shown in Figure 5.

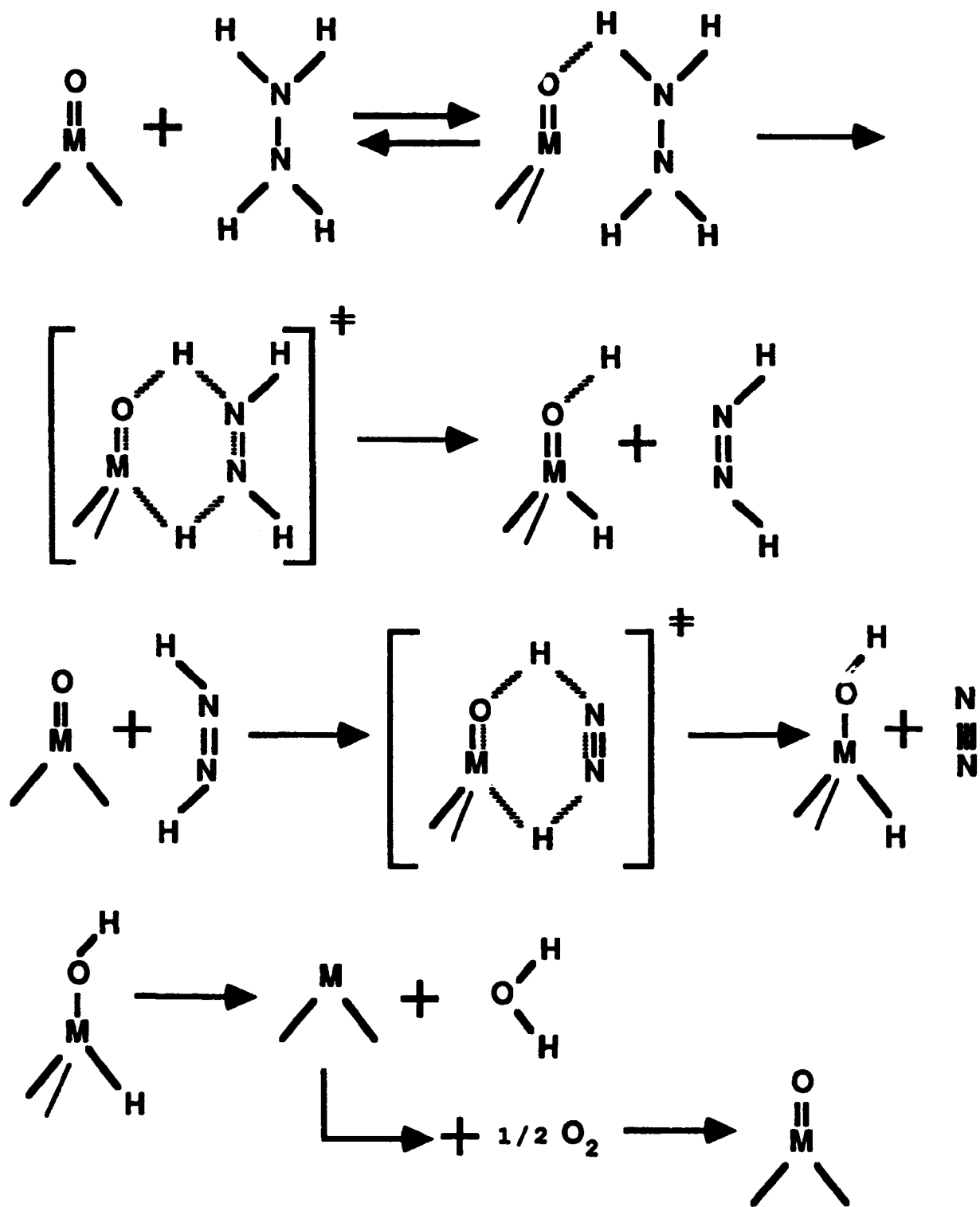


Figure 4. Proposed Reaction Mechanism for Hydrazine with a Prototype Metal Surface Showing Production of Nitrogen and Water.

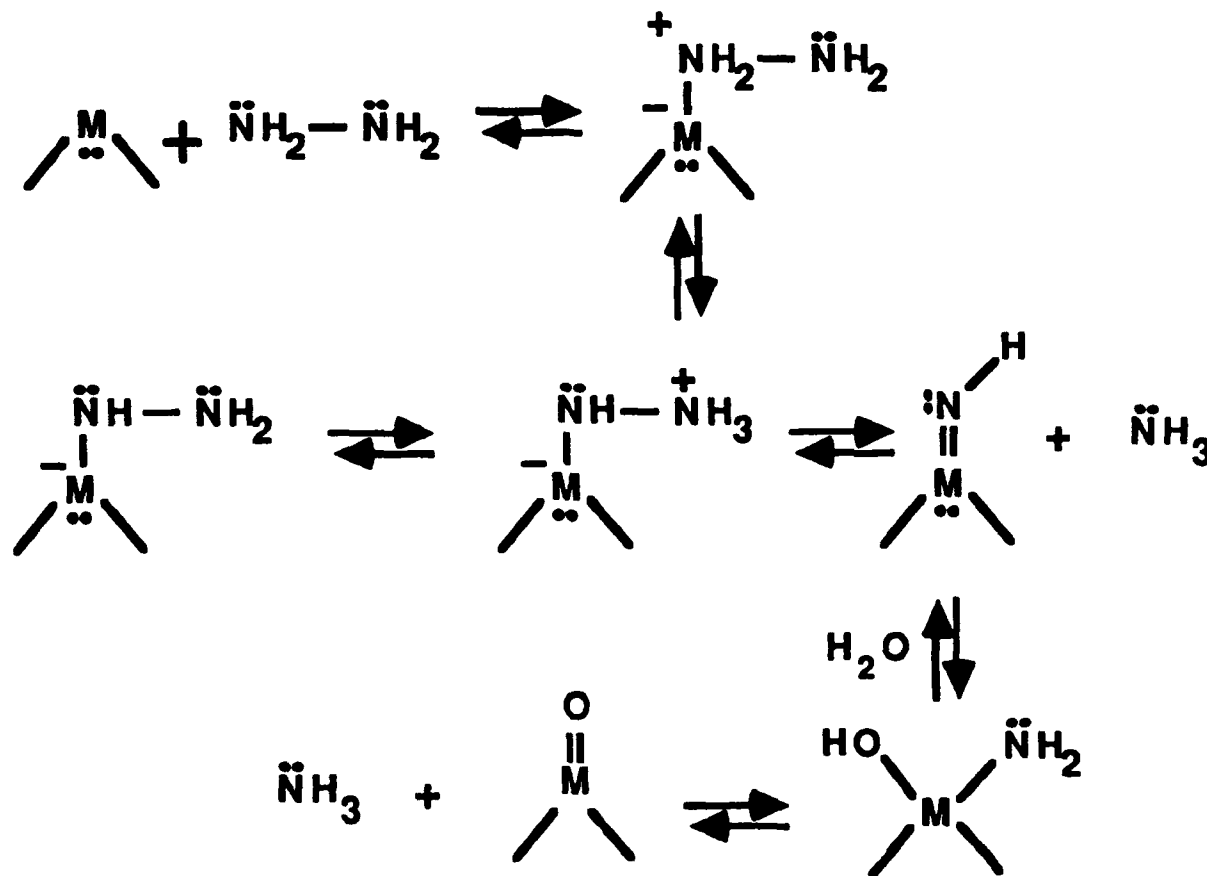


Figure 5. Proposed Reaction Mechanism of Hydrazine with a Prototype Metal Surface Showing Production of Ammonia.

**Tubular Reactors** [26]. Hydrazine reacted completely with all of the substrates tested (i.e., 316 stainless steel [SS], 304L SS, Fe, Al,  $\text{Al}_2\text{O}_3$ , Zn, Cr, Ti, sand, concrete, and powdered cinder block. In runs with an unpacked reactor, HZ recoveries of 89% were recorded. In another series of tests with nitrogen as the carrier gas, HZ was completely recovered from reactors packed with powdered TFE or iron, but was completely consumed by  $\text{Fe}_2\text{O}_3$ .

In the case of MMH with air as the carrier gas, the reaction products were methane, methyldiazene, methanol, and traces of ammonia. Generally, at least three sample injections were required to condition the column and produce stable product chromatograms. The proposed mechanism for these surface-catalyzed reactions is the same as that proposed for the reaction of MMH with  $\text{Al}_2\text{O}_3$  in the large Teflon®-film chamber (Figures 4 and 5).

UDMH proved to be much less reactive than either HZ or MMH in the tubular reactors. Indeed, only trace amounts of products were noted and these were not identified.

## CONCLUSION

The potentially rapid rate and noxious products of the reactions of HZ fuels in air demonstrate the necessity of including not only meteorological but also chemical considerations in the development and employment of atmospheric dispersion models for these fuels.

## REFERENCES

- 1 Finlayson-Pitts, B.J. and Pitts, J.N., Jr. (1986) Atmospheric Chemistry. John Wiley and Sons, New York.
- 2 Pitts, J.N., Jr. Tuazon, E.C., Carter, W.P.L., Winer, A.M. Harris, G.W., Atkinson, R. and Graham, R.A. (1980) Atmospheric Chemistry of Hydrazines: Gas Phase Kinetics and Mechanistic Studies. ESL-TR-80-39, USAF Engineering and Services Center, Tyndall USAF Base, FL 32403, August.
- 3 Tuazon, E.C., Carter, W.P.L., Winer, A.M. and Pitts, J.N., Jr. (1981) Reactions of hydrazines with ozone under simulated atmospheric conditions. Environ. Sci. Technol. 15, 823-828.
- 4 Tuazon, E.C., Carter, W.P.L., Brown, R.V., Atkinson, R., Winer, A.M. and Pitts, J.N., Jr. (1982) Atmospheric Reaction Mechanisms of Amine Fuels. ESL-TR-82-17, USAF Engineering and Services Center, Tyndall USAF Base, FL 32403, March.
- 5 Tuazon, E.C. and Carter, W.P.L. (1988) Atmospheric Chemistry of the Fuel Hydrazines. In: The Third Conference on the Environmental Chemistry of Hydrazine Fuels. ESL-TR-74. USAF Engineering and Services Center, Tyndall USAF Base, FL 32403, January.
- 6 Stone, D.A. and Wiseman, F.L. (1988) Hydrazine Loss Processes in a Teflon® Film Reaction Chamber: Laboratory Results and Kinetic Models. ESL-TR-87-68, USAF Engineering and Services Center, Tyndall USAF Base, FL 32403, March.
- 7 Stone, D.A., Wiseman, F.L., Kilduff, J.E., Koontz, S.L. and Davis, D.D. (Submitted) The disappearance of fuel hydrazine vapors in fluorocarbon-film environmental chambers - Experimental observations and kinetic modeling. Environ. Sci. Technol.
- 8 Kilduff, J.E., Davis, D.D. and Koontz, S.L. (1988) Surface-Catalyzed Air Oxidation of Hydrazines: Environmental Chamber Studies. In: The Third Conference on the Environmental Chemistry of Hydrazine Fuels. ESL-TR-87-74, USAF Engineering and Services Center, Tyndall USAF Base, FL 32403, January.
- 9 White, J.L. (1942) Long optical paths at large aperture. J. Opt. Soc. Am. 32, 285-288.
- 10 Horn, D. and Pimentel, G.C. (1971) 2.5 km Low-temperature multiple-reflection cell. Appl. Opt. 10, 1892-1898.
- 11 Koontz, S.L., Davis, D.D. and Hansen, M. (1988) An Atmospheric Pressure Flow Reactor: Gas-Phase Kinetics and Mechanism in Tropospheric Conditions Without Wall Effects. In: The Third Conference on the Environmental Chemistry of Hydrazine Fuels. ESL-TR-87-74, USAF Engineering and Services Center, Tyndall USAF Base, FL 32403, January.
- 12 Bowen, E.J. and Birley, A.W. (1951) The vapour phase reaction between hydrazine and oxygen. Trans. Faraday Soc. 47, 580-583.

- 13 Winning, W.I.H. (1954) The thermal oxidation of hydrazine vapour. *J. Chem. Soc.* 926-931.
- 14 Stone, D.A. (1978) The Autooxidation of Hydrazine Vapor. CEEDO-TR-78-17, Civil and Environmental Development Office, Tyndall USAF Base, FL 32403, January.
- 15 Bellerby, J.M. (1980) The Autooxidation of Hydrazine and Alkyl Substituted Hydrazine Vapours. Memorandum 92, Propellants, Explosives and Rocket Motor Establishment, Westcott, Aylesbury, Buck, England, May.
- 16 Bellerby, J.M. (1980) The Effects of Reaction Vessel Surfaces on the Vapour Phase Autooxidation of Hydrazines at Ambient Temperature. Memorandum 117, Aylesbury, Buck, England, August.
- 17 Moody, K.N. (1980) The Vapour Phase Oxidation of Hydrazine. PhD Thesis, The University of Leeds, England, April.
- 18 Vernot, E.H., MacEwen, J.D., Geiger, D.L. and Haun, C.C. (1967) The air oxidation of monomethyl hydrazine. *Am. Ind. Hyg. Assoc. J.* 28, 343-347.
- 19 Schmidt, E.W. (1984) Hydrazine and Its Derivatives. Wiley Interscience, New York.
- 20 Stone, D.A. (1979) The Autooxidation of Monomethylhydrazine Vapor. ESL-TR-79-10, USAF Engineering and Services Center, Tyndall USAF Base, FL 32403, April 199.
- 21 Stone, D.A. (1980) The Vapor Phase Autooxidation of Unsymmetrical Dimethylhydrazine and 50-Percent Unsymmetrical Dimethylhydrazine-50-Percent Hydrazine Mixtures. ESL-TR-80-21, USAF Engineering and Services Center, Tyndall USAF Base, FL 32403, April.
- 22 Urry, W.H., Olsen, A.L., Bens, E.M., Kruse, H.W., Ikoku, C. and Gaibel, Z. (1965) Autooxidation of 1,1-Dimethylhydrazine. NAVWEPS Report 8798, U.S. Naval Ordnance Test Station, China Lake, CA, September.
- 23 Loper, G.L. (1978) Gas Phase Kinetic Study of Air Oxidation of UDMH. In: Proceedings of the Conference of Environmental Chemistry of Hydrazine Fuels, CEEDO-TR-78-14, Civil and Environmental Development Office, Tyndall USAF Base, FL 32403, March.
- 24 Naik, D.V. and Stone, D.A. (1984) Air Oxidation of Hydrazine – A Kinetic Study. Final Report, USAF-SCEEE Summer Faculty Research Program, Tyndall USAF Base, FL 32403, September.
- 25 Stone, D.A., Henley, M.V. and Naik, D.V. (1985) The Effects of Surfaces on the Air Oxidation of Hydrazine. Propulsion Information Agency Publication No. 436, November.
- 26 Kilduff, J.E., Davis, D.D. and Koontz, S.L. (1988) Surface-Catalyzed Air Oxidation Reactions of Hydrazines: Tubular Reactor Studies. In: The Third Conference on the Environmental Chemistry of Hydrazine Fuels. ESL-TR-87-74, USAF Engineering and Services Center, Tyndall USAF Base, FL 32403, January.
- 27 Davis, D.D. (1988) Personal Communication, September.
- 28 Harris, G.W., Atkinson, R. and Pitts, J.N., Jr. (1979) Kinetics of the reactions of the OH radical with hydrazine and methylhydrazine. *J. Phys. Chem.* 83, 2557-2559.

## THE APPLICATION OF TOXICOLOGICAL PARAMETERS IN EMERGENCY RESPONSE AND PLANNING

Robin K. Wiener and Deborah K. Silver

*ICF Technology Incorporated, 9300 Lee Highway, Fairfax, VA 22031-1207*

### ABSTRACT

Effective emergency preparedness and response planning is needed to assist responders in making sound decisions under the stressful and confusing conditions accompanying a major accidental release of hazardous materials. One of the most important decisions to be made is the extent and duration of the evacuation of persons located near the accident site. If a decision must be made as to whether or not to evacuate nearby populations, an estimation of the areal extent (sometimes referred to as a toxic hazard corridor or vulnerable zone) of the evacuation must be determined. This corridor, or zone, is based on estimates of the amount of material released, rate of release, vapor dispersion characteristics, and concentration limit or "level of concern" that could cause some damage, irreversible health effects, or death. There is a strong dependency between the concentration limit chosen and the resulting evacuation area dimensions. It is, therefore, important for planners and emergency responders to have accurate estimates of concentration limits as well as guidance in the proper use and interpretation of these limits. This paper will illustrate several causes where the selection of the concentration limits has played an important role.

### INTRODUCTION

While the handling, storage, and transportation of hazardous materials are routine in our society, only recently have the public, Congress, and regulatory agencies begun to realize and address the fact that these substances, in many cases, pose substantial risk to the public as well as to the environment and property. It is paramount that the emergency responder, who is often the only line of defense preventing disastrous loss of life following an accident or release, have state-of-the-art data and the means to interpret and apply those data to the situation at hand. Effective emergency preparedness and response planning is needed to assist responders in making sound decisions under the stressful and confusing conditions accompanying a major accidental release of hazardous materials. One of the most important decisions to be made is the extent and duration of the evacuation of persons located near the accident site. If a decision must be made whether or not to evacuate nearby populations, an estimation of the areal extent of the evacuation must be determined. This is referred to as the "toxic hazard corridor" (THC) by the Department of Defense (DoD) and the "vulnerable zone" by the Environmental Protection Agency (EPA); both terms have the same meaning.

The THC is based on estimates of the amount of material released, rate of release, vapor dispersion characteristics, and concentration limit or "level of concern" that could cause some damage, irreversible health effects, or death. Of the various meteorological, source term, and other chemical and thermodynamic parameters needed for use in these estimates, there is a strong dependency between the concentration limit chosen and the resulting evacuation area dimensions. In general, the THC is proportional to the inverse of the concentration limit squared. Therefore, as the concentration limit is lowered, the corresponding THC length increases, but at a higher rate. Not knowing the consequences of an additional release in terms of a chemical's harmful concentration level is problematic to the government agencies (e.g., the EPA) that are responsible for ensuring public safety, primarily because uncertainty in the concentration level may result in an underestimation or overestimation of the THC. Underestimation of the THC could result in the exposure of many people to a toxic vapor cloud, while overestimation could result in needless and even potentially dangerous evacuation (especially to the elderly or others with health problems). It is, therefore, important for planners and emergency responders to have accurate estimates of concentration limits as well as guidance in the proper use and interpretation of these limits.

#### USE OF TOXICOLOGICAL PARAMETERS

THCs are used in many diverse applications, including (1) risk assessment to determine the extent of exposure, (2) dispersion modeling to calculate THCs, (3) emergency planning to determine vulnerable areas in an accident situation, and (4) emergency response activities. The question in each of these applications is which concentration limit to use. Various organizations have developed exposure guidelines over the years for specific chemicals and applications. However, very few concentration limits have been developed specifically for the applications of risk assessment, emergency response, planning, and dispersion modeling. The limits that have been developed for these specific applications generally are limited in the number of chemicals for which they have been developed. For example, guidelines that are often used are as follows.

- **Threshold Limit Value (TLV).** The TLV was developed by the American Conference of Government Industrial Hygienists for the protection of healthy male workers in the workplace, not the general public.
- **Short-Term Public Emergency Guidance Levels (SPEGLs).** Developed by the National Research Council (NRC) of the National Academy of Sciences (NAS) for the DoD for unpredicted (i.e., accident) short-term exposure to the public. Although these limits have been developed specifically for the application discussed in this paper, SPEGLs have only been developed for five chemicals to date.
- **Permissible Exposure Limits (PELs).** Developed by the Occupational Safety and Health Administration (OSHA) for worker exposure.



- **Immediately Dangerous to Life and Health (IDLH).** Developed by the National Institute for Occupational Safety and Health (NIOSH) exclusively for respiratory selection in the workplace.
- **Emergency Response Planning Guidelines (ERPGs).** The ERPGs currently are under development by a consortium of chemical companies and are based on guidelines published by the NAS. The limits are being developed for community exposure. ERPGs have been developed for approximately 35 chemicals.

The exposure limits mentioned above represent only a limited example of the various exposure guidelines available. As one can see from the list, only the ERPGs and the SPEGLs have been developed specifically for the use of emergency planning, response, and/or risk assessment. However, the number of chemicals for which they can be applied is fairly limited. ERPGs have been developed for 35 chemicals to date, while SPEGLs have only been developed for five. The question then becomes how does one apply these other limits for emergency response/planning when they are not developed for these purposes. Following are several examples of how these limits have been adapted for varying applications, and, in some cases, with less than optimal results.

#### **VANDENBURG AIR FORCE BASE**

Vandenberg Air Force Base (VAFB) in California is the home of the Western Test Range and the site of Delta, Titan, and Atlas launch facilities. These launch vehicles utilize varying amounts of hypergolic propellants (hydrazines and nitrogen tetroxide) which are highly toxic. For this reason, THCs are calculated and plotted at VAFB before initiation of any operation that could or will result in an accidental or planned release of propellants (i.e., those releases that are known to occur during operations such as venting). Predictions are based on analysis of potential sources strength (rate of release of propellant to the atmosphere), the type of propellant involved, exposure limits for the propellant, and prevailing meteorological conditions.

Until recently, the exposure limits used at VAFB to calculate THCs varied depending on the release condition (planned vs. accidental) and the population potentially exposed (workers vs. general public). For planned releases in an occupational environment, VAFB used the TLVs described above. These values are based on a time-weighted average exposure during an 8-h work day and a 40-h work week within which a worker may be repeatedly exposed [1]. For accidental releases in the occupational environment, Emergency Exposure Guidance Levels (EEGLs) were used. EEGLs were developed by the NAS/NRC Committee on Toxicology and are recommended for use in estimating short-term (30 min) worker exposure, not public exposure. The EEGL is a ceiling level for a single, unpredicted exposure lasting 1 h or less and never more than 24 h [2]. Emergency Exposure Guidance Levels take into consideration both the short-term and long-term reproductive, carcinogenic,

neurotoxic, and respiratory effects of a single acute exposure, as well as the age and sensitivity of the population and the length of exposure [1].

For planned releases affecting the general public, limits were derived from the NAS/NRC's short-term public limits (STPLs). Again, the values are based on 30-min exposures. For unsymmetrical dimethylhydrazine (UDMH) and anhydrous hydrazine (AH), the STPL values are one-half the EEGL values. Finally, for accidental releases affecting the general public, the NAS/NRC's public emergency limits, renamed short-term public emergency limits (SPELs), were used. SPELs are defined as single, unpredicted exposures lasting 1 h or less and never more than 24 h, in which the public may experience temporary discomfort or health effects but no irreversible harm [3]. The SPEL is usually used for accidental releases of nitrogen tetroxide ( $N_2O_4$ ) that may involve the public.

Approximately one year ago, the Air Force Surgeon General's office reduced the exposure limits used for the hydrazine fuel at VAFB to new values, called SPEGLs. The SPEL for  $N_2O_4$  also became the official permissible exposure level. These values were adopted for calculating THC's at VAFB and were independent of groups exposed and release type. The new values were taken from SPEGLs developed by NAS/NRC for fuels and SPEL for  $N_2O_2$ . SPEGLs/SPELs are guidance levels for exposure based on a single, unpredicted event lasting 1 h or less, and not more than 24 h, and they are expected to be rare, once-in-a-lifetime occurrences. The SPEGL/SPEL concentration levels are significantly lower than SPEL values (i.e., approximately 1% of the SPEL value for UDMH and AH).

Resulting from this reduction in exposure limits was the generation of much longer THC's. VAFB estimated that the new THC's were as much as 14 times longer than the previous THC's [4] and required much larger areas to be evacuated during normal operations, which impinged on operations unrelated to the material being transferred or utilized. Both 1 STRAD, a division of the Strategic Air Command (SAC), and the Space and Missile Test Organization, a division of AFSC, protested the new longer hazards corridors and petitioned the Air Force Surgeon General to revise the permissible exposure levels. A few months ago the Surgeon General responded by recommending a new set of exposure levels.

These new exposure levels are based on two populations, workers and the public, and two scenarios: (1) the possibility of a release that results from moving or utilizing a hazardous material during planned operations, and (2) a release as a result of an accident or emergency. The use of different hazard corridors for operations and emergencies is similar to the original method of estimating hazard corridors. For planned operations, one-half of the IDLH is used. The IDLH limits were developed by NIOSH as follows.

"IDLHs were developed exclusively for respirator selection in the workplace. . . . The IDLH concentration represents the maximum concentration of a substance in air from which healthy male workers can escape without loss of life or irreversible health effects

under conditions of a maximum 30-min exposure time. . . . EPA recognizes that the IDLH was not designed as a measure of the exposure levels required to protect general populations." (EPA's *Technical Guidance for Hazards Analysis*, p.D-2)

The size of the THC will be drastically reduced using one-half of the IDLH values instead of the SPEGL/SPEL values; THCs for UDMH and A-50 will decrease by a factor of 8, AH by a factor of 15, and  $N_2O_4$  by a factor of 3. However, in the event of an accidental release, the SPEGL/SPEL limits will be used to estimate hazard corridors for evacuation of all personnel.

Both SAC and ASFC have agreed to accept the Surgeon General's recommendation and use the new limits and the two-tier approach, significantly reducing the number of personnel that must be evacuated before operations compared with the SPEGL/SPEL approach. This two-tier approach makes it easier for VAFB to transfer the hazardous materials during planned operations without requiring mass evacuations, while still protecting the public in the event of an accidental release.

#### **DOD SHIPMENTS OF NITROGEN TETROXIDE**

In response to increasing public concern over the relative safety of hazardous materials transportation, the U.S. Department of Transportation (DOT) in 1986 re-evaluated the various exemptions it regularly issues for the transport of chemicals classified as "inhalation hazards." At that time, the DOT placed several new requirements upon the exempted transporters of these materials, including certification that the routes used are the "safest practicable." Nitrogen tetroxide, a propellant used by the DoD, is classified as an inhalation hazard and fell subject to these new requirements. Risk assessment was performed by ICF Technology Incorporated for the DoD on each of the highway routes used to transport  $N_2O_4$ .

The methodology used to calculate risk was based on an assessment of the probability of an accident occurring and the consequences of such an accident. Consequences were calculated in terms of the number of people potentially affected along the route at any one time, using THCs to decide the area affected.

In October of 1987, the Congressional Subcommittee on Government Activities and Transportation held hearings on Capital Hill to address the need for safer highway routing of "ultrahazardous materials" [5]. The hearings highlighted DoD-sponsored shipments of  $N_2O_4$ . Nitrogen tetroxide was selected primarily because it was the only chemical classified as an inhalation hazard for which risk assessments had been performed under the new exemption requirements. One of the issues was the number of persons potentially exposed along each of the routes. Organizations were claiming different numbers of persons exposed. The numbers varied due to several differences, including the use of different dispersion models to calculate the THC, different input parameters (including concentration limits), and different assumptions as to release conditions (i.e., whether or not the propellant would be released under pressure). The Environmental Policy Institute, an

environmental nonprofit organization in Washington, DC, proposed that a 12-mile evacuation corridor be used [6], a representative from Lawrence Livermore National Laboratory suggested 4.6 miles [7], and the DOT recommended 0.8 miles [8]. These differences in corridor length result in significant differences in the total number of persons exposed and resulting risk. The problem was eventually resolved by performing two risk assessments for each route, each using a different corridor length [9]. However, this is not a viable long-term solution. Ultimately, a well-defined exposure limit, used in an acceptable dispersion model, is needed for risk assessment applications.

#### **ENVIRONMENTAL PROTECTION AGENCY**

Approximately two years ago, the Emergency Planning and Community Right-to-Know Act of the Superfund Amendments and Reauthorization Act, also called Title III, was enacted into law. Title III establishes requirements for federal, state, and local governments, as well as industry, regarding emergency planning and community right-to-know reporting for hazardous chemicals. It differs from OSHA's Hazards Communication Standard in that its focus is not on worker right-to-know, but instead, it is intended to provide communities and emergency response organizations with access to information on hazardous chemicals in their community.

The objective of Title III is to improve state and local emergency response and planning and provide the public access to valuable information pertaining to chemicals within their community. Title III required EPA to identify and publish a list of extremely hazardous substances (EHSs) and threshold planning quantities (TPQs) that would establish which facilities are subject to emergency planning under Title III. That is, if a facility produces, uses, or stores an EHS in excess of the EHS's TPQ, it must comply with the requirements under Title III.

In defining the criteria to use for selecting chemicals, EPA has to identify the health effects of concern and identify the data to be used. Acute airborne toxicity was selected as the initial criterion for the selection of chemicals to be listed (EPA has recently begun to look at chemicals that pose flammable, reactive, or explosive hazards to surrounding communities; however, the date that the list will be published is unknown). The EPA decided to focus on animal acute toxicity data with the assumption that humans and animals are similar in susceptibility to toxic chemicals. Lethality data were used because it is the most available and commonly reported information provided from animal toxicity testing and because the EPA wishes to avoid accidents resulting in human death.

Initially, 402 chemicals were listed by EPA. Since that time, four chemicals have been added to the list as a result of new information. An additional 40 chemicals were delisted because they do not meet the acute lethality criteria. The current list of EHSs stands at 366 chemicals [10].

Title III also required local emergency planning committees (LEPCs) to develop emergency plans for accidents involving EHSs within their communities. As part of the emergency plan, vulnerability

analyses had to be performed. A vulnerability analysis is an "assessment of elements in the community that are subject to damage should a hazardous materials release occur; includes gathering information on the extent of the vulnerable zone..." [1] Vulnerability analyses require the calculation of a vulnerability zone distance (VZD), similar to the THCs calculated by the DoD. As part of this calculation, a level of concern (LOC) must be selected. LOCs are defined by EPA as follows.

"Concentration of an EHS above which there may be serious irreversible health effects or death as a result of a single exposure for a relatively short period of time" [1].

EPA does not mandate which exposure limit must be used in the calculation of the VZD, but it has set guidelines. Initially, the EPA recommended that the IDLH be used by LEPCs for the calculation of a VZD. However, there are several problems with using the IDLH in this application. The IDLH is based on the response of a healthy male worker population to toxic exposure and, therefore, does not adequately address the response of sensitive populations, such as children and elderly persons. In addition, the IDLH is based on a 30-min maximum exposure period and it is questionable as to whether or not this is realistic for accidental releases. After consultation with several members of the scientific community, including the Scientific Advisory Board, EPA reduced the recommended LOC to one-tenth the IDLH. This is acknowledged as an interim solution until more appropriate levels allowing a margin of safety are determined.

As discussed earlier, several chemical companies have formed a consortium to develop a more appropriate value for use in these types of applications (the ERPGs). However, ERPGs have been developed for only a handful of chemicals. It is possible that EPA will make revisions to their rulemaking and recommend use of the ERPGs as they become available. This is an ongoing process.

## ISSUES

Chemical manufacturers and other industries are trying to respond to EPA and DOT initiatives for the development of emergency response plans. The development of the ERPGs is one example of industry's initiatives in this area. Another is industry's voluntary efforts in the area of transportation risk assessment and routing evaluations. However, there has been a general frustration on the part of industry as to how they can maximize public safety, minimize their liability, and, at the same time, still allow for normal operations.

There is an obvious need for coordination among all responsible players, including toxicologists, dispersion modelers, planners, and others who are involved in the application of toxicological parameters for the purposes of accurate emergency response/planning and risk assessment methods. Concerted efforts are required of industry and the government to work together to develop appropriate guidelines. Conferences, such as the Annual Conference on Toxicology sponsored by the Harry G. Armstrong Aerospace Medical Research Laboratory and the

Naval Medical Research Institute/Toxicology Detachment, provide excellent forums for communication and the exchange of ideas. Communication is vital to the proper progression of this work by helping to ensure that research and development efforts are proceeding in the direction needed and that ideas are being shared by those who are in need of the information.

#### REFERENCES

- 1 U.S. Environmental Protection Agency (1978) *Technical Guidance for Hazards Analysis*. U.S. EPA, Washington, DC.
- 2 National Research Council *Emergency and Continuous Exposure Guidance Levels for Selected Airborne Contaminants*. Volumes 4 and 5. National Academy Press, Washington, DC.
- 3 ICF Technology Incorporated (1987) *Hypergolic Propellant Hazards Response Guide: Vandenburg AFB*, Volume II. ICF Technology Incorporated, Fairfax, VA.
- 4 Telephone conversation with Daryl Dargitz, WSMC Safety (VAFB) on 4 August 1988.
- 5 *Promoting Safer Highway Routing of Ultrahazardous Cargoes: DOT Oversight (1987)* Thirty-first report by the Committee on Government Operations together with additional views.
- 6 Millar, F. (1987) Statement before the Government Activities and Transportation Subcommittee for the House Committee on Government Operations.
- 7 Koopman, R.P. (1987) Testimony given before the House Government Activities and Transportation Subcommittee of the Committee on Government Operations, Los Angeles, CA, October 19, 1987.
- 8 1987 Emergency Response Guidebook (1987) U.S. Department of Transportation, Research and Special Programs Administration, Office of Hazards Materials Transportation.
- 9 ICF Technology Incorporated (1988) Risk Assessment of Nitrogen Tetroxide Transportation Routes. Prepared for San Antonio-Air Logistic Center, Directorate of Energy Management, Transportation Office, Kelly Air Force Base, San Antonio, TX.
- 10 52 Federal Register 13378-13410.

**SESSION IV**  
**PANEL DISCUSSION**

**Lt Colonel Clewell:** I consider this, personally, to be a very significant issue facing the toxicology community. Our part of it is trying to bring some rationality to the setting of the kinds of limits that are used in these kinds of applications. And what we have seen in this session are examples of two counter-current activities. One is that the estimates of exposure of people to toxic chemical keeps rising. For example, the work at Lawrence Livermore has demonstrated that what was considered only a drinking water exposure is also an inhalation exposure, so now people consider themselves exposed to a greater quantity of toxic materials. At the same time, there has been a consistent tendency on the part of not only regulatory agencies but even scientific advisory boards and scientific groups to recommend lower and lower exposure limits for chemicals. Every time the USAF goes back to the National Academy of Science and asks about the hydrazine fuels they give us a lower number. I don't know when we will learn and stop asking. The problem is that people keep coming up with new effects of the same old materials, new ways of finding out that there is an effect of the same old materials, or new arguments for the significance of the chronic effects of these materials. In particular, what I feel is of considerable concern to those of us who have been involved in this kind of thing for a number of years is the growing tendency to consider the carcinogenic potential for a once in a lifetime, unplanned, accidental exposure to a possible animal carcinogen and try to use quantitative risk assessment, which then drives an exposure limit. That is what happened to hydrazine. And so that ends up increasing the hazard corridors and the planning considerations for a chemical, not for something that is a repetitive exposure in the workplace where one would be concerned about the chronic toxicity, but for a once in a lifetime possible, unplanned single exposure. So what happens then is that as the estimate of exposure goes up and the estimate of allowable exposure goes down, you eventually reach a crunch where it is no longer possible to live with the limit operationally. People will go along with a hazard limit as long as it is operationally achievable. The USAF went along with whatever the National Academy of Science Committee on Toxicology recommended until Vandenberg AFB found out they could no longer support operations. I went to the American Industrial Hygienist Committee meeting last May and learned all about the Emergency Response Planning Guidelines (ERPGs). The significant thing about the ERPGs is that there are three levels. There is the ERPG-1 level at which people will either smell it, see it, or begin to worry about it for some reason, so you had better tell them that it is okay even though it is at a harmless level. There is the ERPG-2 level which is essentially equivalent to the National Academy of Science Short-Term Public Emergency Guidance Limits (SPEGL). It is based actually on the rationale behind the SPEGL which the Committee on Toxicology developed for the USAF. And it is the level that is in

the region of 0.1 to 0.5 for the hydrazines, which is hard to live with. Then there is ERPG-3 which corresponds very closely to the National Institute for Occupational Safety and Health (NIOSH) Immediately Dangerous to Life or Health (IDLH).

I was really amazed because I had just got through recommending that we go to a two-tier system using half the IDLH and the SPEGL. You cannot live with the SPEGL operationally or cost effectively in the community. The community really cannot do emergency action plans for every chemical based on their SPEGLs or any equivalent kind of concentration limit that is based on the fact that this might be an animal carcinogen and that it might be an exposure once in a lifetime. So what I am leading to, to kind of get things started with the panel, is to ask is there any way out of here? Is there any way to avoid getting ourselves into a position where society cannot afford to use the exposure limits that we in the toxicology community keep recommending, given our exposure assessment and people's ability to keep finding more and more sources of threat?

**Weiner:** I am not a toxicologist. I was really hoping, because we do not have the answers, that the toxicologists have the answers. I do not know what is going to happen.

**Layton:** We look at the environment and I think that there is a large number of people that view the environment or the chemicals in the environment as "most of the things are harmless and there are a couple of things that are really bad. Once we discover those, we have to address all our resources to eliminating our exposure to those compounds." I think that there is an alternative view that does not really come across, and perhaps when people figure out this might be a more realistic view, they are going to be upset at the whole system for misleading them. Perhaps there are many toxic substances or many compounds that are toxic at high levels but not toxic at low levels, that we are exposed to all the time. Somehow this system that we are involved in – and the media interacts with it, and it is a very complex process – seems to be getting the message out that there is always something bad, and if it is bad, we have to do something drastic about it. I do not know how we stop that process of seeing this problem with toxic substances as being one of one tree at a time instead of a forest of varying toxicities, varying exposures, and things that we have to regulate with some sort of logical, reasonable approach, and not extreme overreactions on all counts.

**Dr Bruce Stuart (A.D. Little):** I think we are not totally without hope. It depends on how long you think the tunnel is, and whether there is a bright light at the end of it or not, and what the walls of the tunnel are lined with. I would like to make a plea, however, that when emergency planning response guidelines or whatever it may be that is invoked to set a provisional guide (somehow these become fossilized into standards if one is not careful), that one looks at the data bases. Look at the data bases; these have been misused in the case of the American Conference of Governmental Industrial Hygienists, which are indeed also focused upon the healthy worker and not all workers.



However, the data bases that are available in terms of documentation of threshold limit values are valid and can be used and analyzed by any thinking toxicologist to see how well they will fit the particular exposure scenario they are talking about. If one uses that instead of an arbitrary correction factor, such as dividing by a factor of four for the time and a factor of ten for the fact that you have some unknown sensitive population, I think you can begin to wisely recommend what will be there, for at least a provisional guideline. I would hate to go back to the other approach because that was a recommendation in 1959 by the International Commission of Radiation Protection, which published a parallel list for occupational exposures and environmental exposures for all radionuclides, and they use just that, a factor of 40. With the caveat, however, of saying wherever additional data are available for a particular radionuclide, use that and make your best scientific judgment.

I think that we run into problems like the business of using the IDLH, a tenth of the IDLH, whatever it may be, when people look for a shortcut, and simply use some arbitrary correction factor and try to apply it across the board. This is one of the areas I might indicate that toxicokinetics should shine in because it deals with the absorbed dose and not an exposure dose, and it can deal with unusual exposure scenarios based upon the material or toxic metabolite and indeed whether or not it is the area under the curve accumulated for the carcinogenic endpoint, or an irritation index, peak blood level, or whatever it may be that is the index of concern.

**Dr Fred Miller (EPA):** I am not in the regulatory part of EPA, but I would like to throw out a comment relative to the IDLH and how that ended up. It was in recognition of the fact that when you test any particular chemical, by-and-large, every time you go to sensitive subpopulations you find that it is at least a factor of ten lower that they respond. So it is not a hocus-pocus calculation relative to IDLH. There is not a data base for Bhopal, for example. Toxicology was not designed for having that kind of data available and yet the public is demanding that you do something about it. And so you really are trapped by not having the data – I do not care what organization you are – to really do your operational corrections. And it sounds like Vandenburg, quite frankly, got around the situation by taking one-half of the IDLH so they are operational as opposed to recognizing that, in fact, you really had toxicology, it may be that for that particular compound it is acceptable, but for many compounds dividing by two would not be acceptable. I would argue that rather than worrying about it that way, maybe we ought to find safer ways for containment. Because, as Harvey points out, you are not going to guard against the one-time chance that you finally do have an accident. I would think that some aspects of safer containment might do us more good, and also improving the dispersion models – the Puff Model, or whatever they are using, and getting that refined – may do us more good than to try to argue about the toxicology data itself, because it seems like a tremendous waste of resources to try to generate the data base that would be needed for the toxicology of those compounds in this chance setting. It just does not seem like we are ever going to get there that way.

**Weiner:** I do agree. I guess this is a limited presentation in one respect in that we just addressed toxicity parameters. One of the other ways of combating this is also through better emergency response practices and containment protection.

**Clewell:** In defense of the USAF, I might point out that in the case of nitrogen tetroxide, for example, we paid for the Lawrence Livermore study that demonstrated that the dispersion characteristics of nitrogen tetroxide made it a more extensive hazard during a spill than was previously expected, and we pushed the Department of Transportation (DOT) to accept that increased factor of three. And, at the same time, the USAF has also upgraded the tanker that carries nitrogen tetroxide even though it was already at least an order of magnitude better tanker than for an equally toxic material that is transported in your backyard all the time, chlorine. But of course when I was in Los Angeles about the nitrogen tetroxide issue, I asked the Fire Chief what about chlorine, and he said, "Oh, we don't worry about chlorine. We know how to handle that." I mean, it was a war gas in World War I. It is more toxic than nitrogen tetroxide. But I will not get on that soapbox. But, of course, you will want all three: better containment, better dispersion modeling, and better toxicity estimates. But a nagging question remains unanswered: How do you fold in a carcinogenic risk for these kinds of materials incidents?

**Dr Ray Yang (NIEHS):** I have a question for Dr Thomas McKone. I am very interested in your modeling of household exposure situations, but as I recalled reading in a paper and seeing in the news about indoor air pollutants, there are probably 9 to 15 very, very frequently seen pollutants from carpet, furniture, cooking, smoking, and so on. I wonder if you and/or your colleagues have made any attempts to do mixture modeling of all these chemicals at one time.

**McKone:** I would like to refer you to the work of the TEAM studies out of EPA. Their surveys indicate that for a lot of the more common items such as trichloroethylene, perchloroethylene, and a number of others, the primary source is probably not drinking water. The way that they found this out was by comparing what they were finding indoors to what was in the water supply, and they could find no consistent ratio across the country for different areas. The only compound that they clearly could identify was chloroform. So I think it raises an interesting issue. It says that for some of these common volatile organics that we are concerned about, indoor air is probably the primary place where people are being exposed, and it is probably not industrial emissions, but it is probably household products that we bring into our own home. I think that it is a caveat that should be added to some of the work that we are doing that some of the compounds that we are saying first if you are going to regulate it, do not just regulate on the basis of the ingestion exposure, look at the inhalation exposure indoors. But, second, you should look at the relative contribution. For example, for a compound like trichloroethylene, if you are going to regulate it, do not assume it is all coming in through the drinking water. And also, do not assume that just drinking water or soil is the only

source of it. There are many sources of the compound. So we need this broader, integrated, assessment of how chemicals that are in commerce end up coming in contact with people. And I think a lot of this is just opening up. There really is not enough out there about this broader multipathway, multimedia view of the world. We tend to divide these problems into pieces, like an air problem, or an indoor air problem, or a soil problem, and then regulate it one piece at a time and not as an integrated whole.

**Yang:** So you and your colleagues have not attempted that in terms of modeling for mixtures?

**McKone:** No, we have not modeled whole compounds.

**Yang:** Is anybody you know of doing something along this line?

**McKone:** Not that I know of. You were talking about mixtures in the sense of the exposure to mixtures or whether . . . ?

**Yang:** Yes, simultaneous exposure to the 9 to 15 chemicals.

**McKone:** For concentrations indoors, when we are at parts-per-million in the water supply or less (I am saying that I have not run the experiment but just from what I understand of mass transfer properties) when you have concentrations that low, you do not expect there to be a substantial difference if there is more than one compound present as long as the concentration is that low....

**Yang:** I am not so sure about that.

**McKone:** Well, because you do not get a change in the relative diffusion unless you have a high enough concentration of both compounds that they have a likely probability of colliding with one another during the mass transfer process. Which, if they are both in parts-per-billion, it is fairly low.

**Yang:** Well, I think this is a very important area from the point of view of Dr. Douglas's talk yesterday of submarine atmospheres. And you know, many of us traveled by plane to get here and we live in our own house and so on. I think these are very, very important issues and a lot of this modeling still is based on one chemical. Personally, I would urge that type of research should really be looked at.

**McKone:** I think also that modeling of mixtures kind of presupposes that you know how to handle the dose response for the mixtures. Why would you want to do it in terms of the mixture? Otherwise, you are going to do it compound by compound, maybe add up the effect so there is that end of it. Once you do that, what are you going to do with it? Unless there are methodologies for handling mixtures of gases with different endpoints ranging from inhibition of multifunction oxidase to eye irritation, you know, multiple endpoints is pretty difficult.

**Yang:** For many of these chemicals, these kind of effects are known.

**Dr Clay Frederick (Rohm and Haas):** I would just like to comment on this issue of perceived risk and what threshold limit value or whatever you use in association with exposure of a chemical. I really feel that society does not want to assume any risk at all with the fruits of civilization. That is the current perception. And we can talk about this being a reasonable level of risk in terms of risk assessment from some chemical exposure, from some catastrophic situation. I think, reasonably, as toxicologists, we can define what we think is a reasonable risk to be carried by society for the fruits of civilization. But I think the general perception of people outside our profession is there is only one acceptable answer and that is zero risk. And to be specific, in terms of products, if you are talking about something like permanent-press clothes, it seems like everybody wants permanent-press clothes, but if you start playing up the fact that there may be formaldehyde released by permanent-press clothes, well that is clearly unacceptable. Get that stuff out of there. Now, if, in fact, you had to do that and get rid of all the permanent-press clothes that would be unacceptable, too. You have got to have the fruits of civilization but none of the risks. It is a tough issue and the press really makes a mess of it.

**Yang:** Dr Layton, plants are an important part of our natural environment and may some day be an important part of confined environments, therefore I would like to know if you have considered the role of plant life in your modeling?

**Layton:** We did, but in a very simple fashion, and that is we assumed that the concentration of organic contaminants and biota in general in the water portion of the plant was equivalent to the concentration of the contaminant in the water portion of the soil, and that, basically, was a very straightforward default assumption. In our review of the literature, we feel that of the many different aspects of the parameterization process that you have to go through in looking at chemicals, that plant uptake of organic compounds is one of the big data gaps that is out there right now. And there is information in the literature for pesticides and herbicides obviously, because of the concern of uptake from soils. But when you take compounds like trichloroethylene and others, there is virtually no data. There are some regression equations that use the relationship between different physical/chemical parameters and uptake. Other than that, there is very little data. We do have the parameter in the model for uptake. But the estimation for most chemicals is virtually nonexistent.

**Dr Ed Houston (NSI):** My question is directed to Dr Stuart. Bruce, as you indicated, during the process of selling a house, I have become intently interested in radon. On the detection side, as I understand it, they are detecting alpha emitters, either the radon gas or the radon daughters. My question is, is there anything else out there that contributes to the alpha emitters that would compound these sorts of readings?

**Stuart:** Part of the fact that we have inherited this planet, or been given it, depending on your point of view, is the fact that there are four radioactive decay chains, that, starting with uranium 238, are the most abundant in terms of activity. Radon daughters stemming from radium itself is the most abundant chain. The question of whether there are other alpha emitters out there is a good one, and I think I can probably assure you that those are the only ones that you have to worry about. A statement was made that nitrogen tetroxide was billed as the most hazardous chemical known to man. It was not very many years ago that people were talking about plutonium dioxide (a product from weapons fallout) in that regard, and that it was of sufficient toxicity that breaking off the very tip of the lead of your pencil is sufficient to provide a dose of pulmonary carcinoma. I worked about 12 years with that stuff, and it can be handled reasonably. But there are not many alpha emitters out there that you really have to become concerned about. For a while there was a record discharge unit that used an americium source that is no longer around. My feeling is that the levels that may be of residual alpha stemming from weapons release a couple of decades ago are so minute that the chances of finding anything like that as a contributory factor are vanishingly small. Having said that, I am reminded of the fact that there is a satellite coming back out of orbit now, placed by a European country, USSR, which has a nuclear power supply in it, and it is guaranteed not to break up or vaporize upon re-entry. So that may or may not present a problem, but in terms of the levels that you encounter in your homes from alpha, this can vary in one spot within your home severalfold depending upon the time of year, the activity in the home, the barometric conditions at the time, and so forth. So I thank you for the opportunity to say that even if you have the test done, and you happen to end up with 4.5 pci/L liter or something equally worrisome, do it again and maybe pick some other area of the home, and some other climatological conditions, and shed a little light that way.

**Dr. Ray Kutzman (NSI):** Mine is really a question for clarification. Do I understand that with the hazardous corridor system that there are local emergency planning committees mandated by someone, the Department of Defense or DOT?

**Weiner:** Title III of the Superfund Amendments and Reauthorization Act requires that local emergency planning committees are set up, and I believe that the EPCs are composed of members from local facilities or local industries, as well as the local Government.

**Kutzman:** That is who sits on them? How are they coordinated around the country, or do you have very different attitudes on handling nitrogen tetroxide at the production plant and at the fueling station?

**Weiner:** I am sure that there are very different attitudes about it throughout the country. There is also a requirement that state planning committees be set up. They are coordinated with the local committees.

**SESSION V**

**ADVANCED TECHNIQUES IN HAZARD ASSESSMENT**

**Dr Melvin E. Andersen, Chairman**

**RECENT CANCER RESEARCH RESULTS REQUIRED RISK ASSESSMENT CHANGES**

James D. Wilson

*Monsanto Company (A2NE), 800 N. Lindberg Blvd.,*

*St. Louis, MO 63167*

*(Manuscript Not Submitted)*



## **EVALUATION OF UNCERTAINTY IN INPUT PARAMETERS TO PHARMACOKINETIC MODELS AND THE RESULTING UNCERTAINTY IN OUTPUT**

David Farrar, Bruce Allen, Kenny Crump, Annette Shipp

*Clement Associates, Inc., 1201 Gaines Street, Ruston, LA 71270*

### **SUMMARY**

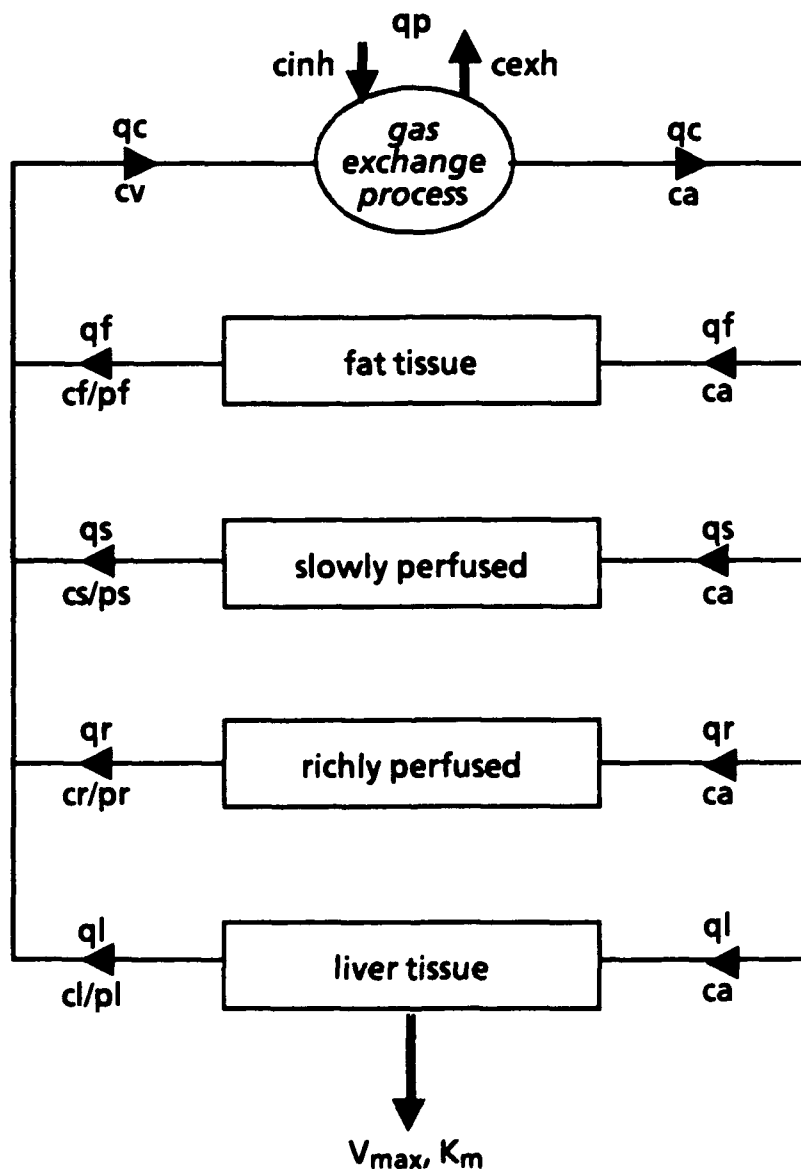
Physiologically based pharmacokinetic (PB-PK) models may be used to predict the concentrations of parent chemical or metabolites in tissues, resulting from specified chemical exposures. An important application of PB-PK modeling is in assessment of carcinogenic risks to humans, based on animal data. The parameters of a PB-PK model may include metabolic parameters, blood/air and tissue/blood partition coefficients, and physiological parameters, such as organ weights and blood flow rates. Uncertainty in estimates of these parameters results in uncertainty regarding tissue concentrations and resulting risks. Data are reviewed relevant to the quantification of these uncertainties, for a PB-PK model-based risk assessment for tetrachloroethylene. Probability distributions are developed to express uncertainty in model parameters, and uncertainties are propagated by a sequence of operations that simulates processes recognized as contributing to estimates of human risk. Distributions of PB-PK model output and human risk estimates are used to characterize uncertainty resulting from uncertainty in model parameters.

Physiologically based pharmacokinetic models can be used in the animal-based assessment of human cancer risks. A PB-PK model is assumed for rodents and humans (with parameter values that are possibly species-specific) and dose surrogates are calculated on the basis of that model. A dose surrogate is a particular measure of chemical delivered to a putative target tissue. The dose surrogate values corresponding to the dose levels and dose regimen followed in a chosen carcinogenicity bioassay and the observed tumor count data are the input to dose-response model (e.g., the multistage of Weibull models [1]). Values of the chosen surrogate dose are estimated for humans, corresponding to specified external exposures, and human risks are estimated based on the fitted dose-response curve.

This report describes the development of methods for analyzing the effect of uncertainties associated with PB-PK model parameters. The methods are illustrated in the context of a risk assessment for tetrachloroethylene that employs a multicompartment PB-PK model and a carcinogenic endpoint observed in female mice [2].

**PHYSIOLOGICALLY BASED PHARMACOKINETIC MODEL FOR TETRACHLOROETHYLENE**

The EPA [3] and Hattis et al. [4] have developed two slightly different PB-PK models for tetrachloroethylene. Reitz and Nolan [5] have reviewed the parameter values adopted by the EPA and have recommended some revisions. In order to evaluate uncertainties within the framework of a given PB-PK model, analyses presented here are based on the EPA model (Figure 1). Flow-limited compartments and Michaelis-Menten metabolism (occurring in the liver) are assumed.



**Figure 1. Tetrachloroethylene PB-PK Model.** Notation:  $cinh$ ,  $cexh$ ,  $ca$ , and  $cv$  are concentration of parent in inhaled air, exhaled air, arterial blood, and venous blood;  $qi$ ,  $ci$ , and  $pi$  are the perfusion rate, parent concentration, and tissue/blood partition coefficient for compartment  $i$ ; and  $V_{max}$  and  $K_m$  are constants determining the rate of metabolism in the liver.

Notation and preferred values for model parameters are listed in Table 1. In general, the definition of model parameters and the units adopted follow Reitz and Nolan [5]. Absolute compartment volumes,  $v_i$  (in liters), are related to compartment proportions ( $v_{ic}$ , Table 1) by

$$v_i = v_{ic} * bw \quad (i=l, r, s, f) \quad (1)$$

where  $bw$  is body weight in kilograms. The maximal metabolic rate,  $V_{max}$ , is scaled according to  $V_{max} = V_{maxc} * bw^{0.74}$  [5]. The  $v_{ic}$  and  $V_{maxc}$  parameters are those for which uncertainties are estimated.

The partition coefficients that are measured directly *in vitro* are limited to some of the tissue/gas coefficients ( $p_b$  and  $p_{gi}$ ,  $i = l, r, s, f$ ). Tissue/blood partition coefficients, which are those actually used in the PB-PK model, are estimated by dividing the tissue/gas coefficients by the blood/gas coefficient ( $p_i = p_{gi}/p_b$ ,  $i = l, r, s, f$ ).

The dose surrogates that are estimated herein, and for which uncertainties are estimated, are (1) the average daily area under the liver concentration-time curve for the parent (AUCL), (2) the average daily area under the arterial blood concentration-time curve for the parent (AUCA), and (3) the average daily amount of parent metabolized per volume of liver tissue (CML).

#### PARAMETER UNCERTAINTY EVALUATION FOR THE TETRACHLOROETHYLENE MODEL

For each parameter we have identified a preferred value (Table 1), and have specified a probability distribution to represent uncertainty. The preferred value represents some summary of information available from the literature (see below). The probability distribution is selected in such a way as to assign relatively high probability to values that are close to the preferred value. A useful device for communicating uncertainties is to define an "uncertainty factor" ( $UF \geq 1$ ), such that for a preferred parameter value,  $h_p$ , the range of values  $h_p/UF$  to  $h_p * UF$  is considered highly probable (we assume probability 95%). Table 1 gives uncertainty factors estimated from the observed distributions of the values generated for the parameters, which are based on the probability distributions described below.

Specification of probability distributions to express uncertainty in parameter values involves, first of all, selection of appropriate families of distributions for individual parameters, or in some cases for groups of interrelated parameters. The families selected for expressing uncertainty are the lognormal or truncated lognormal family (for partition coefficients and metabolic constants) and the Dirichlet family (for compartment volumes as proportions of total body volume). Other PB-PK model parameters are functionally related to the compartment volumes, and their empirical distributions depend on the distribution of the volumes.

Uncertainty factors were derived largely on the basis of analyses of variation in reported measurements or estimates. That being the case, different sources of uncertainty and variation must

**TABLE 1. PARAMETERS OF THE TETRACHLOROETHYLENE PB-PK MODEL, WITH PREFERRED VALUES AND UNCERTAINTY FACTORS (UF<sup>a</sup>)**

Parameter	Preferred Values (UFs)	
	Mice	Humans
Body Weight (bw; kg)	0.028	70
Compartment Proportions (range 0-1)		
Liver (v <sub>l</sub> )	0.056 (1.24)	0.026 (1.35)
Rapidly perf. (v <sub>rd</sub> )	0.049 (1.24)	0.050 (1.25)
Slowly perf. (v <sub>sd</sub> )	0.767 (1.03)	0.620 (1.04)
Fat (v <sub>f</sub> )	0.049 (1.25)	0.230 (1.09)
Cardiac Output (1/h) (q <sub>c</sub> )	1.13 <sup>b</sup> (1.08)	348 <sup>c</sup> (1.12)
Waking value: (q <sub>cw</sub> )	-	486 <sup>d</sup> (1.12)
Alveolar Ventilation Rate (1/h)		
(q <sub>p</sub> )	1.64 <sup>b</sup> (1.11)	288 <sup>c</sup> (1.50)
Walking value: (q <sub>pw</sub> )	-	683 <sup>d</sup> (1.26)
Compartment Perfusions (1/h)		
Liver (q <sub>l</sub> )	0.180 (1.24)	90.6 (1.35)
Rapid perf. (q <sub>r</sub> )	0.367 (1.24)	153 (1.25)
Slowly perf. (q <sub>s</sub> )	0.518 (1.01)	87.0 (1.04)
Waking value (q <sub>sw</sub> )	-	225 (1.17)
Fat (q <sub>f</sub> )	0.065 (1.25)	17.4 (1.09)
Partition Coefficients (unitless)		
Blood/gas (p <sub>b</sub> )	16.9 (1.97)	12.0 (1.97)
Liver/blood (p <sup>l</sup> )	3.01 (2.69)	5.05 (9.37)
Liver/gas (p <sub>lg</sub> )	50.9 (1.97)	60.6 (8.36)
Rapid/blood (p <sub>r</sub> )	3.01 (4.14)	5.05 (5.69)
Rapid/gas (p <sub>rg</sub> )	50.9 (3.51)	60.6 (4.92)
Slow/blood (p <sub>s</sub> )	2.59 (2.54)	2.66 (11.0)
Slow/gas (p <sub>sg</sub> )	43.8 (1.97)	31.9 (10.1)
Fat/blood (p <sub>f</sub> )	48.3 (2.56)	102 (2.89)
Fat/gas (p <sub>fg</sub> )	816 (1.93)	1230 (2.15)
Metabolic Constants		
V <sub>maxc</sub> (mg/h)	3.96 (2.83)	0.33 (2.84)
K <sub>m</sub> (mg/L)	1.47 (12.4)	1.86 (12.3)

<sup>a</sup> The uncertainty factors are estimated from 1000 Latin-hypercube samples such that for preferred values h<sub>p</sub>, the interval from h<sub>p</sub>/UF to h<sub>p</sub>\*UF contains 95% of the values.

<sup>b</sup> Preferred values for mice, 24 h per day.

<sup>c</sup> Preferred values for sleeping humans, 8 h per day.

<sup>d</sup> Preferred values for waking humans, 16 h per day.

be recognized. Variation among average measurements reported in different experiments represents a different source or sources of uncertainty than variation among measurements taken on different individuals in the same experiment. Furthermore, when a parameter value is not measured directly so that a value of another variable is attributed to that parameter, additional uncertainty theoretically requires combining distributions representing multiple levels of uncertainty.

Of interest for test species PB-PK parameters is uncertainty with respect to an average parameter value. This is the case because an aggregate response variable (proportion of animals with tumor) is to be related to an aggregate predictor (the single dose surrogate value assumed for a treatment group). For humans, in contrast, interest is in individual variation of dose surrogate levels due to variation in PB-PK model parameter values. Therefore, for humans, it is desirable to incorporate into an estimate of relevant total uncertainty a component representing interindividual variation specifically. Consequently the probability distributions derived below for humans apply to individuals selected at random, but distributions derived for rodents apply to mean values for groups of animals in the bioassay considered.

Presented here are uncertainty derivations for mice and humans. The concepts exemplified by the analysis for mice generalize to other test species.

### ***Partition Coefficients***

Preferred values for tissue/gas partition coefficients (equated with the medians of the lognormal distributions characterizing uncertainties) are taken from Reitz and Nolan [5]. The blood/gas preferred value (12) is the geometric mean of the value from Reitz and Nolan [5] (10.3) and three values (9.1, 13.1, and 18.9) reported by Fiserova-Bergerova [6].

Three sources of uncertainty are recognized, one or more of which are relevant to the estimation of total uncertainty for a given partition coefficient. For parameters measured directly by vial equilibration techniques, uncertainty is due to differences in values estimated in different experiments (source 1). These parameters are the rodent blood/gas, liver/gas, fat/gas, and slow/gas (actually muscle/gas) and to the human blood/gas coefficients. The nonmeasured parameters – the rapid/gas coefficient in rodents (equated to the rodent liver/gas coefficient) and all tissue/gas coefficients other than blood/gas in humans (equated to the average of the corresponding coefficients estimated in rats and mice) – have additional uncertainty due to the attribution of the measured values to those parameter values (source 2). For all human coefficients, individual variation also is relevant (source 3).

Each source of uncertainty is represented by a separate lognormal distribution with specified geometric standard deviation (GSD). Therefore, the distribution describing total uncertainty also is lognormal, with geometric variance (squared geometric standard deviation) given by the sum of geometric variances expressing specific contributing uncertainties. Details of the derivation of source-specific uncertainty distributions are available from the authors.

It is common practice in uncertainty analyses to derive distribution parameters by directly assigning subjective probabilities to ranges of parameter values [7]. An analogous procedure has been used here to modify the uncertainty estimates for the partition coefficients.

Plausible constraints on values of partition coefficients are  $p_{gw} < p_{gi} < p_{gf} < p_{go}$ ,  $i = l, r, s, b$ , where  $p_{gw}$  and the  $p_{go}$  are the water/gas and oil/gas partition coefficients, respectively. Using the preferred values (Table 1) and source-specific uncertainty factors as discussed above to define the lognormal distributions, the value of  $p_{gf}$  will be larger than the value of 1917 estimated for  $p_{go}$  by Sato and Nakajima [8], with probability about 20%. Similarly, in sampling from lognormal distributions for the partition coefficients, values of other tissue/gas partition coefficients were occasionally larger than values of the fat/gas coefficient. (Other suggested constraints were violated with very low probability.) Consequently, the distribution of the fat/gas partition coefficient was truncated at 1917, and other tissue/gas coefficients were truncated at the value of the fat/gas coefficient. These adjustments represent a significant alteration of both the shape and the variance of the distribution representing uncertainty of the fat/gas partition coefficient, and relatively slight alteration of the distributions for other tissue/gas partition coefficients.

### **Compartment Volumes**

For each species, uncertainty regarding compartment proportions of total body volume is expressed using the Dirichlet distribution. For a set of random, complementary proportions, the Dirichlet distribution function can be expressed in terms of the expected proportions and a parameter  $\Phi$  which determines the variances and covariances of the random proportions [9]. Consequently, it is convenient to equate the preferred proportions  $v_{icP}$ ,  $i = l, r, s, f$  (given in Table 1) to the expectations of the corresponding random proportions  $v_{ic}$ ,  $i = l, r, s, f$ . The value chosen for  $\Phi$  expresses the uncertainty regarding the joint distribution of the proportions; more specifically variance of  $v_{ic}$  is given by

$$\text{Var}[v_{ic}] = v_{icP} * (1 - v_{icP}) / (\Phi + 1), i = l, r, s, f. \quad (2)$$

Fixing the variance of one compartment proportion determines  $\Phi$ . Variation in liver volume had been used because preliminary analysis revealed that, for the three dose surrogates studied and for inhalation exposure, the model is roughly equally sensitive to all compartment volumes (for the AUCL and AUCA surrogates) or more sensitive to the liver volume than to other volumes (for the CML surrogate). Also, published information is incorporated easily because the compartment is identified unambiguously with a specific organ.

On the basis of liver volume measurements for mice reported in Arms and Travis [10], the preferred value of  $v_{lc}$  and  $\Phi$  for mice are estimated to be 0.056 and 1456, respectively. Volume

proportions for other compartments are taken from Reitz and Nolan [5], adjusted for the change in  $v_{lc}$ .

For humans, the parameter value of  $v_{lc}$  (0.026) also is taken from Arms and Travis [10] and other volume proportions from Reitz and Nolan [5], adjusted, again, for the difference between  $v_{lc}$  values from the two sources. For  $\Phi$ , individual variation should be considered (as discussed above). Data on individual variation in liver volume in humans (as a proportion of body weight) are not available. Caster et al. [11] report variances of  $v_{lc}$  estimates for individual rats, which we assume to express plausible levels of individual variation for humans. Using the value from Caster et al. [11] in Equation 1, the solution for  $\Phi$  is 1621. We tentatively adopt this value to represent uncertainty for humans, noting, however, that individual differences do not account for total uncertainty regarding compartment volumes, so that some underestimate of uncertainty is possible.

### ***Circulatory and Ventilatory Parameters***

The parameters defining the compartment proportions of body volume, cardiac output ( $q_c$ ), ventilatory output ( $q_p$ ), and perfusion rates of specific compartments ( $q_i$ ,  $i = l, r, s, f$ ) are functionally interrelated. An account presented here demonstrates the sort of physiological considerations that are relevant, along with possibilities for quantifying the way that these considerations may determine uncertainty. Data regarding circulatory and ventilatory parameters for rodents and humans have been summarized by Arms and Travis [10].

Distributions for  $q_c$ ,  $q_p$ , and the  $q_i$ 's are derived as follows.

1. Given a  $v_{lc}$  value sampled from the Dirichlet distribution and the corresponding absolute compartment volume,  $v_i$ ,  $q_i$  (the absolute compartment perfusion rate) is given by  $q_i = v_i \cdot (q_{icp} \cdot q_{cp}) / v_{ip}$  where  $q_{icp}$  is the preferred proportion of total cardiac output directed to compartment  $i$  [10] and  $q_{cp}$  is the preferred total cardiac output. The total cardiac output then is given by  $q_c = q_l + q_r + q_s + q_f$ . These values of total and compartment-specific perfusion are assumed to hold for sleeping humans and for rodents during all hours.
2. For humans, sleeping and waking values of cardiac output and alveolar ventilation rate are desired. The "waking" value,  $q_{cw}$ , is computed by  $q_{cw} = q_c + (q_{cwp} - q_{cp}) \cdot edq_c$ , where  $q_c$  is the "sleeping" value computed in step 1,  $q_{cp}$  and  $q_{cwp}$  are preferred values for sleeping and waking individuals, and  $edq_c$  is distributed lognormally with preferred value 1 and uncertainty factor to be specified. The increment to total cardiac volume is assumed to be directed entirely to the slowly perfused compartment. Preferred values of waking and sleeping cardiac output and alveolar ventilation rate are derived from Hattis et al. [4].

An uncertainty factor for  $edq_c$  also is based on the data presented in Hattis et al. [4]. An arbitrarily low probability (0.001) is assigned to an increment in  $q_c$  values ( $q_{cw} - q_c$ ) as large as the difference between values for sleeping and light exercise (234 L/h). Using this difference, the assumed difference in preferred values ( $q_{cwp} - q_{cp} = 138$ ), the lognormal distribution assumed for  $edq_c$ , and the relationship

between the GSD of the distribution and the associated UF, the uncertainty factor of 1.3 is obtained.

3. Ventilatory volume ( $q_p$ ) is assumed to be related linearly to the cardiac volume ( $q_c$ ). For humans,  $q_p - q_{pp} = ((q_{pwP} - q_{pp}) / (q_{cwP} - q_{cp})) * (q_c - q_{cp})$ . The same relationship holds for waking values,  $q_{pw}$  and  $q_{cw}$ . For mice, an analogous treatment requires specification of a second  $q_c - q_p$  coordinate (to replace  $q_{cwP}$  and  $q_{pwP}$ ), in addition to the values representing ordinary activity levels. Data from anesthetized mice have been used to determine the second coordinate [10].

### **Metabolic Constants**

After scaling  $V_{max}$  estimates (to get  $V_{maxc}$  values) and expressing  $K_m$  in comparable units, geometric means of the values reported in Hattis et al. [4] and Reitz and Nolan [5] are equated with the preferred values.

It is assumed here that the uncertainty regarding the metabolic parameters arises chiefly from different experimental approaches and assumptions applied in deriving estimates. It may be argued that an uncertainty factor based on a geometric standard error is an appropriate measure of uncertainty; the geometric standard error is related inversely to the sample size, representing formally the inverse relationship between uncertainty and additional information. However, such a formalization is based on the assumption that the available measurements are independent and identically distributed (i.i.d). The estimates of metabolic constants are suspected to deviate strongly from these assumptions. A likely pattern of deviation from the i.i.d case is for clusters of estimates based on similar procedures to assume similar values. Such a pattern can lead to too-small estimates of uncertainty. Here, some conservatism (implying greater uncertainty) is introduced by basing an uncertainty factor on the geometric standard deviation rather than the geometric standard error. In other words, uncertainty regarding the metabolic constants is represented by a lognormal distribution having the same geometric standard deviation as the sample geometric standard deviation computed from the available estimates [4,5].

A tentative uncertainty factor for  $V_{maxc}$  is given by  $\exp(2*0.532) = 2.9$ , for mice and humans, where 0.532 is a GSD derived as a weighted average of species-specific GSD values. Uncertainty for  $K_m$  is evaluated in a similar manner, resulting in an uncertainty factor of 13 for mice and humans. The representation of uncertainty with respect to these metabolic constants is considered problematic, especially because their estimation via optimization of the model fit to *in vivo* data is dependent on estimates for the other model parameters. The discussion elaborates on this point.



## PROPAGATION OF PARAMETER UNCERTAINTIES

### Procedure

Parameter distributions for mice and humans were sampled using the Latin-hypercube method [7,12]. For each random selection of parameter values, the operation depicted in Figure 2 was performed to generate distributions of dose surrogate values and risk estimates.

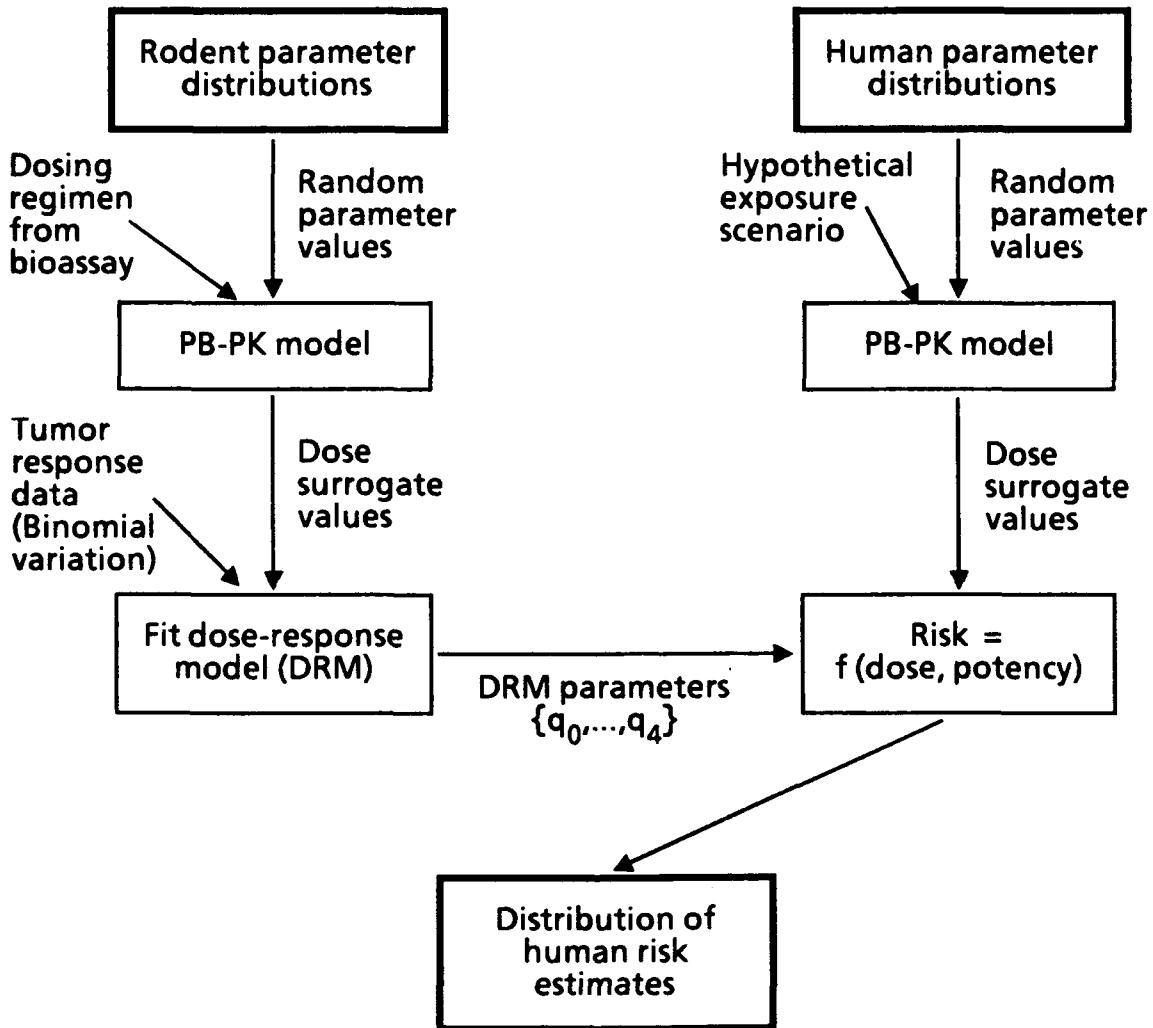


Figure 2. Propagation of Parameter Uncertainties for PB-PK Model-Based Risk Assessment.

In order to characterize uncertainty in the three dose surrogates (AUCL, AUCA, and CML), 100 sets of parameters were generated and the PB-PK model was run for each set. Mice were exposed as in the carcinogenicity bioassay: via inhalation at 0 ppm, 100 ppm, and 200 ppm, for 6 h/day in five consecutive days per week [2]. Humans were assumed to be exposed to 50 ppm (the current OSHA standard) for 8 h/day in five consecutive days per week.

Uncertainty in dose surrogate values was propagated further to evaluate uncertainty in human risk estimates. A single tumor response, hepatocellular carcinoma, is considered here for illustrative purposes.

Surrogate dose values were related to the tumor response rates using a version of GLOBAL82 [13] to implement the multistage model. For the estimation of risk uncertainty, tumor response rates also were considered uncertain. For each of 100 randomly generated sets of dose surrogate values (one dose surrogate value per treatment group) the multistage model with a fixed number of stages was refitted, based on those dose surrogate values and random tumor counts for the treatment groups generated from a binomial distribution with parameters  $N_i$  and  $p_i$ . Here  $N_i$  is the number of animals in treatment group  $i$  (48 at 0 ppm, 50 at 100 and 200 ppm), while  $p_i$  is the estimated response proportion for dose group  $i$  obtained by fitting the multistage model to the observed response rates (1 at 0 ppm, 13 at 100 ppm, and 36 at 200 ppm) and the dose surrogate values corresponding to the preferred mouse parameter values.

Finally, a distribution of human maximum-likelihood and upper bound estimates of risk were generated by pairing each of the 100 sets of multistage model parameters with a randomly selected human dose surrogate value corresponding to the human exposure scenario of interest. Extra risk is defined by  $R = (P[d] - P[0]) / (1 - P[0])$ , when  $P(d)$  is the lifetime probability of observing a tumor given exposure that results in a surrogate dose value of  $d$ . No adjustments were made to the risk estimates obtained in this manner. Thus, for example, no adjustment was made to account for the somewhat different proportions of the human and mouse lifespans lived prior to first exposure.

## RESULTS

Table 2 gives selected percentiles for the distributions of human dose surrogate values and extra risks. Median surrogate values are approximately equal to the dose surrogate values computed using preferred parameter values, which are 23.9 for AUCA, 118 for AUCL, and 27.8 for CML.

Median risk estimates vary substantially among the three surrogate doses. For comparison, consider the risks estimated in the "traditional" manner, using applied doses with no pharmacokinetic transformations (Table 3). Maximum-likelihood risk estimates obtained without using a PB-PK model (assuming mice and humans are equally susceptible to doses expressed in milligrams per kilogram of body weight per day) are higher than maximum-likelihood estimates (MLEs) based on metabolite in liver, but lower than MLEs based on parent concentrations. For tetrachloroethylene, it appears that the structural uncertainty associated with the selection of an appropriate dose metric for cross-species extrapolation is of relatively greater importance than is the uncertainty associated with the values of the PB-PK model parameters.

**TABLE 2. SELECTED PERCENTILES FROM THE SIMULATED DISTRIBUTIONS OF HUMAN DOSE SURROGATE AND RISK VALUES (BASED ON 100 LATIN-HYPERCUBE SAMPLES)**

Surrogate	Percentiles				
	2.5	25.0	50.0	75.0	97.5
<b>Dose Surrogates</b>					
AUCA (average daily area under the arterial concentration curve, mg/h/L)	12.1	18.9	24.4	30.3	43.8
AUCL (average daily area under the liver concentration curve, mg/h/L)	13.1	54.9	116	243	1060
CML (average daily amount metabolized per liver volume, mg/L)	2.24	13.9	27.8	51.8	117
<b>MLEs of Extra Risk<sup>a</sup></b>					
AUCA	0.0275	0.0910	0.164	0.243	0.494
AUCL	0.0391	0.244	0.480	0.700	0.982
CML	3.65E-9	3.73E-5	8.50E-4	7.06E-3	0.0495

<sup>a</sup> Extra risk is  $(P[d] - P[O]) / (1 - P[O])$ , where  $P(d)$  is the lifetime probability of tumor when exposed to dose  $d$ . Here  $d$  corresponds to an 8-h/day, 5-day/week exposure to 50 ppm.

**TABLE 3. RISK ESTIMATES<sup>a</sup> OBTAINED WITHOUT USE OF A PB-PK MODEL, AND USING THE PB-PK MODEL WITH NO UNCERTAINTY**

Analysis	Risk Estimates	
	MLE	Upper Bound
No PB-PK transformation <sup>b</sup>	$5.57 \times 10^{-3}$	$4.28 \times 10^{-2}$
<b>PB-PK transformation with no uncertainty</b>		
AUCA	0.126	0.238
AUCL	0.425	0.506
CML	$1.95 \times 10^{-5}$	$7.00 \times 10^{-3}$

<sup>a</sup> Extra risk for 8-h/day, 5-day/week exposures to 50 ppm.

<sup>b</sup> Humans and mice are assumed to be equally susceptible to tetrachloroethylene when administered doses are expressed in milligram per kilogram per day.

Also shown in Table 3 are the risk estimates obtained by using the preferred mouse and human PB-PK parameters to estimate risk (i.e., the risk estimates that would be obtained if the parameter values were known without uncertainty to be equal to the preferred values). Except for the estimates based on CML, the median of the simulated risk estimates is close to the risk estimate obtained with no uncertainty. In the case of CML, risks tend to be skewed to the right in comparison with the estimate corresponding to the preferred parameter values. This is a result of the fact that the linear term of the multistage model fit to the preferred-value dose and response data is zero. Alteration of CML doses and response rates introduced in the course of the uncertainty analysis cannot decrease

the linear term and this would tend to increase the risk estimates at the relatively low dose corresponding to the human exposure scenario. With the AUCL and AUCA surrogates, the linear terms are positive when the multistage model is fit to the observed response rates and doses corresponding to the preferred parameter values.

## DISCUSSION AND SUMMARY

Evaluations of the carcinogenicity of tetrachloroethylene have implicated a metabolite as the moiety responsible for the tumorigenic responses following exposure [14]. The high degree of nonlinearity between the CML dose surrogate and the hepatocellular carcinoma response rates in female mice (as discussed in the preceding paragraph) is interesting in that light. Either there are nonlinear steps, in addition to the saturable metabolic transformation, leading to the interaction that initiates the carcinomas (i.e., the surrogate represented by CML is not close enough to the events causing cancer to yield linearity between that measure of dose and the response), or the PB-PK model is not adequate for describing tetrachloroethylene pharmacokinetics. We are continuing investigation of tetrachloroethylene carcinogenicity in hopes of elucidating the substance and the mechanisms responsible. This may entail the development of alternative means of characterizing and calculating the risks.

The approach to uncertainty analysis that has been illustrated in the context of *tetrachloroethylene risk assessment* has several features that are essential for an appropriate uncertainty assessment. First, the uncertainties related to the PB-PK model parameters are formally expressed in terms of probability distributions that can incorporate multiple levels (or sources) of uncertainty. The parameter uncertainty distributions are based on the inspection and analysis of relevant data, sometimes in combination with the application of more subjective evaluations (or those based on expert opinion) of reasonable bounds for particular parameter values. Second, the parameters are not, in general, regarded as being independent of one another. The implied correlation structures (as, for example, among the volumes of the compartments) are modeled using multivariate distributions. Moreover, certain assumed functional relationships between the parameters have been maintained, even though the magnitudes of those relationships (the ratio of cardiac and pulmonary rates, for example) are subject to uncertainty. Finally, the approach employs an efficient technique (Monte Carlo simulation using the Latin-hypercube procedure) to make explicit the relationships between parameter uncertainties and uncertainties in dose surrogate values and risk estimates.

By far the most difficult aspect of this approach is the characterization of the uncertainties in the parameters. This requires extensive review of the literature and attention to the different sources of uncertainty that are inherent in the observed variations in measurements. It is appropriate to

stress that the estimates of uncertainty derived here are tentative. First of all, as illustrated by the measurement of individual variation in liver volume as a proportion of body weight, various GSD estimates are not based on data that are directly relevant, but on data from contexts that are considered more or less analogous to the context of immediate interest. Moreover, the variations identified with specific sources of uncertainty may not reflect only those sources of uncertainty. For example, individual variation will contribute to observed variation between mean measurements reported by different laboratories, particularly if the number of animals per mean is small.

Certain parameters are difficult to measure and equally difficult to characterize with respect to their uncertainty. When parameter estimates are based upon data collected *in vivo*, as is the case with metabolic constants, the values obtained are determined in part by the values assumed for other physiological parameters, as well as by the structural assumptions underlying the PB-PK model. Also, uncertainties in estimates of parameters fitted simultaneously by an optimization program are not independent because the fit of the model to the data is determined jointly by all of the fitted parameters. Information on the correlation among estimates of such parameters is necessary for a complete treatment of their uncertainty. This information is not currently available, and so, for example,  $V_{max}$  and  $K_m$  are treated as though they were independently determined. Because of these difficulties, the evaluation of uncertainty for metabolic constants could be improved by techniques that account for the uncertainty in the other parameters and that simultaneously estimated uncertainty for  $V_{max}$  and  $K_m$ .

Other refinements to the characterization of uncertainties in PB-PK model parameters are possible. In particular, the use of variance components analysis to derive more pure estimates of source-specific uncertainties is of interest.

The results of the analysis, the distributions of surrogate doses and of risk estimates, have several potential uses. The distribution of simulated risk estimates can be interpreted as follows, keeping in mind the fact that, precisely because of uncertainty with respect to the parameter values and individual variation, consideration of a single risk estimate is not adequate. The proportion,  $P$ , of the simulated estimates that falls in an interval,  $I$ , may be interpreted as the probability that the true risk for a randomly selected individual is in  $I$ , when the uncertainties are taken into account. This interpretation should be useful in risk management decision-making contexts. One major advantage of this type of analysis (i.e., risk assessment that uses PB-PK modeling and considers input uncertainties) is that reasonable variations in risk estimates become explicit. Traditionally, using administered doses, the uncertainties associated with the point estimates of risk have not been emphasized.

The distributions of the dose surrogates and the risk estimates result from uncertainties concerning true (average) values as well as variation around those averages. The uncertainty regarding the true values is theoretically reducible via further experimentation. The approach illustrated here can assist in directing the efforts to reduce uncertainty. If, for example, a set of parameters is fixed at an assumed average value, the reduction in the spread of the risk estimates, below that obtained when all parameters are allowed to vary, provides an indication of the potential value of additional information with respect to that set of parameters. Such analyses take into account both sensitivity of model output to the values assumed for the parameters and the current level of uncertainty regarding the parameters.

The approach to uncertainty analysis presented here has been illustrated for a simple PB-PK model for tetrachloroethylene. It is applicable to PB-PK models of greater complexity as well. Some of the parameters of those models – such as partition coefficients, compartment volumes, and flow rates – are identical to those parameters, the ground work has been laid here for their analysis. In general, the considerations described here are meaningful and useful for any analysis of PB-PK model-based risk assessment.

#### ACKNOWLEDGMENTS

The research reported was supported by Contract #F33615-86-C-0552 for the Department of the Air Force, Harry G. Armstrong Aerospace Medical Research Laboratory. Chris Rambin produced computer programs implementing procedures described.

#### REFERENCES

- 1 Crump, K. (1985) Methods for carcinogenic risk assessment. In: P. Ricci, (Ed.), Principles of Health Risk Assessment. Prentice-Hall, Englewood Cliffs, NJ, pp. 279-319.
- 2 National Toxicology Program (NTP) (1985) Technical Report on the Toxicology and Carcinogenesis Studies of Tetrachloroethylene (Perchloroethylene) (CAS No. 127-18-4) in F344/N Rats and B6C3F<sub>1</sub> Mice (Inhalation Studies). NTP TR 311. NIH Publication No. 85-2567.
- 3 Environmental Protection Agency (EPA) (1983) Health Assessment Document for Tetrachloroethylene (Perchloroethylene). External Review Draft. EPA-600/8-82-005B.
- 4 Hattis, D., Tuler, S., Finkelstein, L. and Zhi-Quan, L. (1986) A Pharmacokinetic/Mechanism-Based Analysis of the Carcinogenic Risk of Perchloroethylene. Center for Technology, Policy and Industrial Development, Massachusetts Institute of Technology, No. CTPID 86-7.
- 5 Reitz, R.H. and Nolan, R.J. (1986) Physiological Pharmacokinetic Modeling for Perchloroethylene Dose Adjustment. Unpublished data submitted to EPA Science Advisory Board.

- 6 Fiserova-Bergerova, V. (1983) *Gases and their solubility, a review of fundamentals. Volume I. Modeling of Inhalation Exposure to Vapors: Uptake, Distribution, and Elimination.* CRC Press, Boca Raton, FL.
- 7 McKay, M., Conover, W. and Beckman, R. (1979) A comparison of three methods for selecting values of input variables in the analysis of output of computer code. *Technometrics* 21(2), 239-245.
- 8 Sato, A. and Nakajima, T. (1979) Partition coefficients of some aromatic hydrocarbons and ketones in water, blood, and oil. *Br. J. Ind. Med.* 36, 231-234.
- 9 Johnson, N. and Kotz, S. (1972) *Distributions in Statistics: Continuous Multivariate Distributions.* Wiley, NY.
- 10 Arms, A. and Travis, C. (1986) *Reference Physiological Parameters in Pharmacokinetic Modeling.* Oak Ridge National Laboratory, Oak Ridge, TN.
- 11 Caster, W., Poncelet, J., Simon, A. and Armstrong, W. (1956) Tissue weights of the rat. I. Normal values determined by dissection and chemical methods. *Proc. Soc. Exp. Biol. Med.* 91, 122-126.
- 12 Iman, R. and Helton, J. (1988) An investigation of uncertainty and sensitivity analysis techniques for computer models. *Risk Anal.* 8(1), 71-90.
- 13 Howe, R. and Crump, K. (1982) *GLOBAL 82: A Computer Program to Extrapolate Quantal Animal Toxicity Data to Low Doses.* Prepared for the Office of Carcinogen Standards, OSHA, U.S. Department of Labor, Contract 41USC252C3.
- 14 Reichert, D. (1983) Biological actions and interactions of tetrachloroethylene. *Mutat. Res.* 123, 411-429.

**RISK ASSESSMENT GUIDELINES**

William Farland

*U.S. Environmental Protection Agency, OHEA/ORD RD689,  
401 M St., SW, Washington, DC 20460*

*(Manuscript Not Submitted)*



## DEALING WITH UNCERTAINTY IN CHEMICAL RISK ANALYSIS

David S. Clement<sup>1</sup> and Joseph A. Tatman<sup>2</sup>

<sup>1</sup>*Defense Logistics Agency Operations Research Office, Defense General Supply Center,  
Richmond, VA 23297*

<sup>2</sup>*Strategic Decisions Program, Air Force Institute of Technology, Wright-Patterson AFB, OH 45433*

### SUMMARY

For a given chemical there are usually several methods for estimating the risk. Each method is based on different assumptions. Additionally, with advances made in pharmacokinetics, regulatory agencies have come under pressure to re-evaluate their procedures for assigning risk. A tree diagram was generated to describe the combinations of assumptions made by each unit risk method. A subjective weight was assigned to each assumption (branch of the tree) to characterize its validity in estimating the risk. From this a weighted average of risk was calculated. An example involving methylene chloride (DCM) illustrates the decomposition method of estimating chemical risk.

### INTRODUCTION

A basic problem facing the U.S. Environmental Protection Agency (EPA) is selecting what method to use in determining the unit risk number of a chemical that has been shown to be carcinogenic in animals and/or humans. Traditionally, experimental animal studies and particular statistical methods have been used in determining the unit risk number. Recently, physiologically based pharmacokinetic models (PB-PK) "have been developed for a variety of volatile and nonvolatile chemicals, and their ability to perform the extrapolations needed in risk assessment has been demonstrated" [1].

The EPA is responsible for assigning unit risk numbers to chemicals that have been shown to be carcinogenic. The unit risk number dictates the cleanliness standard to which a hazardous waste site must be cleaned. A high probability unit risk number means tougher exposure standards. Tougher standards make for higher clean up costs. The higher costs add up to fewer hazardous waste sites getting cleaned. With increasing public support for cleaning all hazardous waste sites, the EPA is driven to use its limited budget for cleaning up as many hazardous waste sites as possible. If the unit risk number is unreasonably conservative the budget is wasted on over cleaning. But if the unit risk is set too low, people are exposed to a greater risk than is publicly acceptable. Of course nobody wants an unsafe environment, but wasting precious resources on overly stringent clean-up standards is poor policy.

The EPA is interested in improving the way the unit risk numbers are determined for carcinogens. What is needed is a method that addresses the uncertainties associated with the various techniques for assigning chemical risk and combines them, including the PB-PK modeling techniques, into one cohesive unit risk assessment process.

This study develops a methodology for assigning unit risk numbers by decomposing the traditional methods and the PB-PK modeling techniques into their corresponding assumptions. A subjective weighting then is assigned to each assumption to characterize its validity in estimating the risk. From this a weighted average of unit risk is calculated.

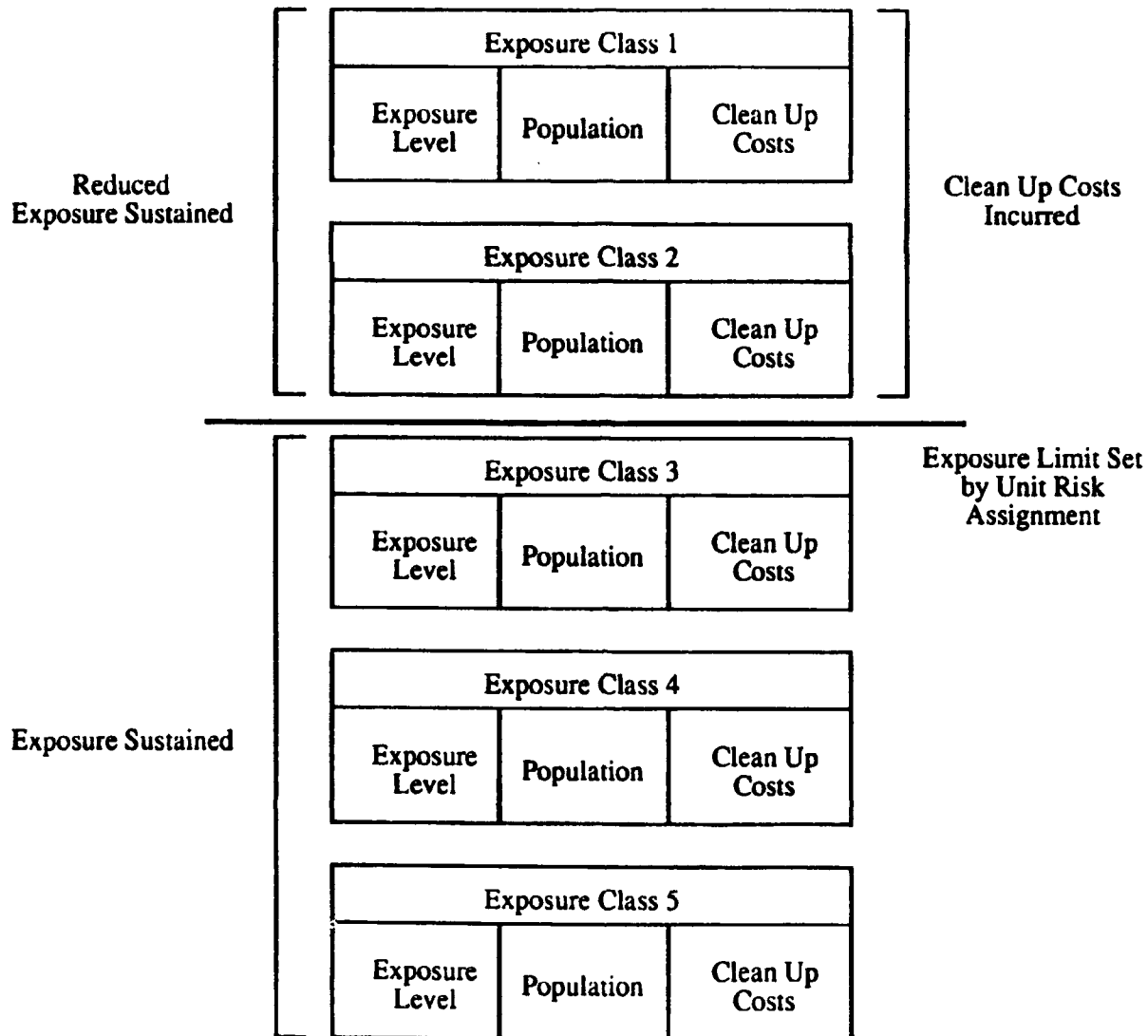
A general discussion of dealing with uncertainty of the unit risk within a decision analytical framework consisting of decision, uncertainty, and values is presented first. Then, a method for dividing the unit risk methods into their various assumptions using tree diagrams is presented. Finally, an example involving DCM, an important industrial solvent, is given to illustrate the decomposition method.

#### **DECISION ANALYTICAL FRAMEWORK**

The first thing that we would like to do is to treat the problem of assigning unit risk numbers within a cohesive, comprehensive framework. We chose decision analysis as our tool for doing this [2]. We developed the idea of exposure classes illustrated in Figure 1 as the foundation of our modeling effort. As illustrated in Figure 1, we establish a set of exposure classes where each class is defined by an exposure level, a population (number of people in that exposure class, each exposed to the exposure level of that class) and a cost function that provides the amount of money it will cost to clean-up that exposure class to a specific exposure level. In the figure, these exposure classes are arranged from highest exposure level at the top to lowest exposure level at the bottom. This is a very general idea. An exposure class might correspond to a specific hazardous waste site, to workers in a specific profession, or to the public exposed to a hazardous chemical at a certain level.

When a unit risk number is assigned by the EPA for a specific chemical, a maximum allowable exposure level (MAEL) is automatically dictated. Say that this MAEL falls between exposure classes 2 and 3 in Figure 1. This means that all exposure classes above this line must be cleaned up to a level consistent with the MAEL. Exposure classes below this line do not need to be dealt with.

The clean-up costs for exposure classes above the MAEL will be incurred. Again note that the amount of clean-up costs for an exposure class will depend on how much it has to be cleaned up, that is, where the MAEL falls.



**Figure 1. Exposure Class Formulation.**

Populations in the exposure classes above the MAEL will sustain a reduced exposure due to the clean up, while the populations in the exposure classes below the MAEL will sustain the initial, unchanged exposure level.

Therefore we can see what happens as the MAEL is increased and decreased, moved up and down in Figure 1. As this level is moved up, fewer exposure classes will have to be cleaned up and the costs of these clean-ups will decrease. On the other hand, a greater number of people will sustain the initial exposure level and the risks implied by that exposure. As the MAEL is lowered, more exposure classes will need to be cleaned up and the cost of these clean-ups will grow larger. However, fewer people will sustain the initial, unreduced exposure level.

That is the tradeoff. As the maximum allowable exposure level moves up, the clean-up costs decrease but the human cost increases. As it moves down, the clean-up costs increase, but the human costs decrease. The EPA, in assigning a unit risk number and therefore a maximum allowable exposure level, must balance these two opposing costs.

We have built a spreadsheet model based on Figure 1. This model is only meant to be a demonstration of our technique. The structure and the parameters in the model would need considerable fine tuning before the model would be useful for decision making. The parameters and variables used in the spreadsheet model are defined as follows.

Legal Unit Risk:	Unit risk number to be assigned by the EPA.
Actual Unit Risk:	The actual risk of the chemical.
Clean-up Costs:	Total clean-up costs incurred by all exposure classes that must be cleaned up.
Cancer Costs:	Total costs due to populations in the exposure classes developing cancer (total number of cancers times the cost per cancer).
Total Costs:	Sum of clean-up costs and cancer costs.
Cost of One Cancer:	The cost to be assigned by the user of one person contracting cancer.
Exposure Class n Population:	The population of exposure class n.
Clean-up Effectiveness:	If an exposure class must be cleaned up to exposure level $l$ , then the actual clean-up will be $f \cdot l$ where $f$ is greater than or equal to one. We call $f$ the clean-up effectiveness.

The spreadsheet model allows the user to vary the 13 parameters and explore the effect on the Total Costs for the model. The sensitivity of total costs to these 13 parameters was explored in a deterministic sensitivity analysis. The results are shown in Figure 2. Note that the most critical parameters are Cost of One Cancer, Actual Unit Risk, Clean-up Effectiveness, Legal Unit Risk assigned by the EPA and the populations of the two most hazardous exposure levels, Exposure Class 1 Population and Exposure Class 2 Population.

in decision analysis we only carry the most important variables forward to the stochastic phase, because it is very expensive to obtain probability distributions for random variables. In this case we carry forward the six variables listed above.

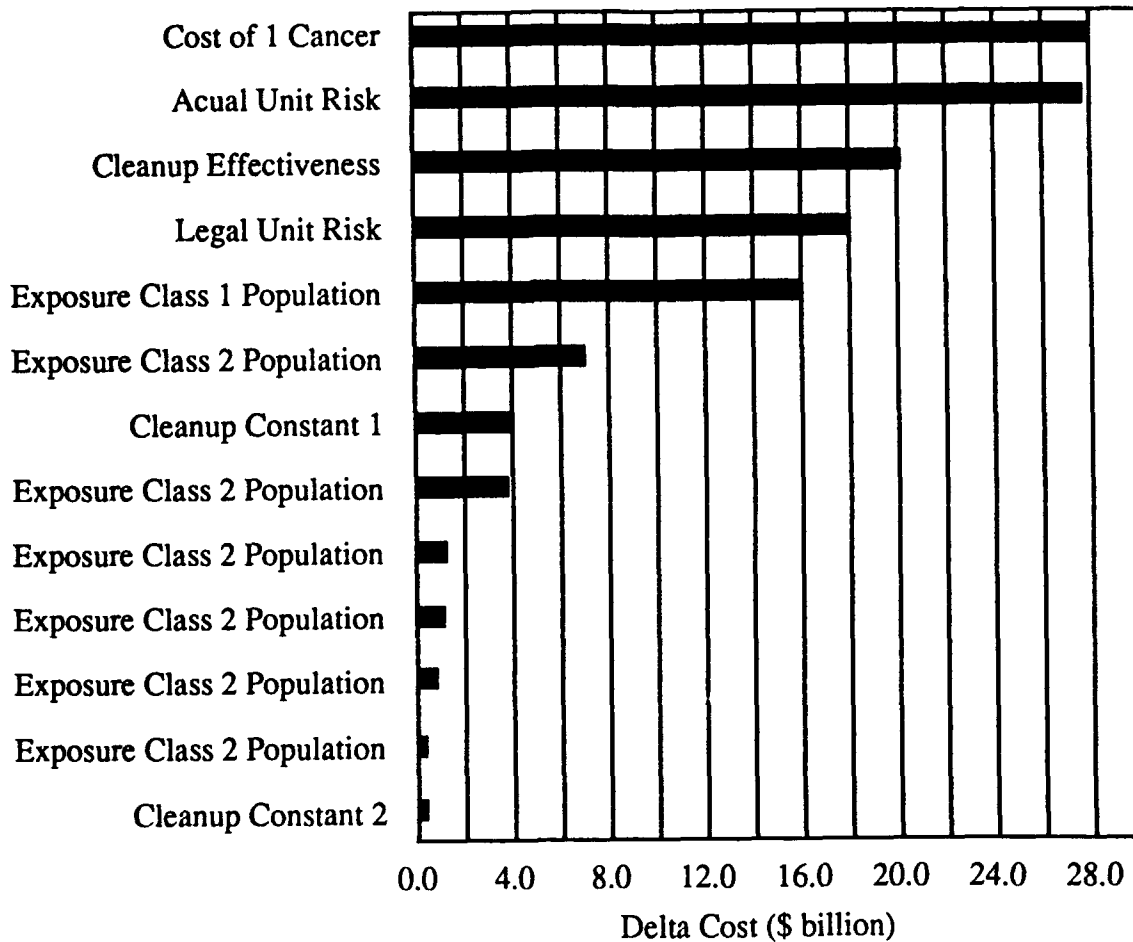
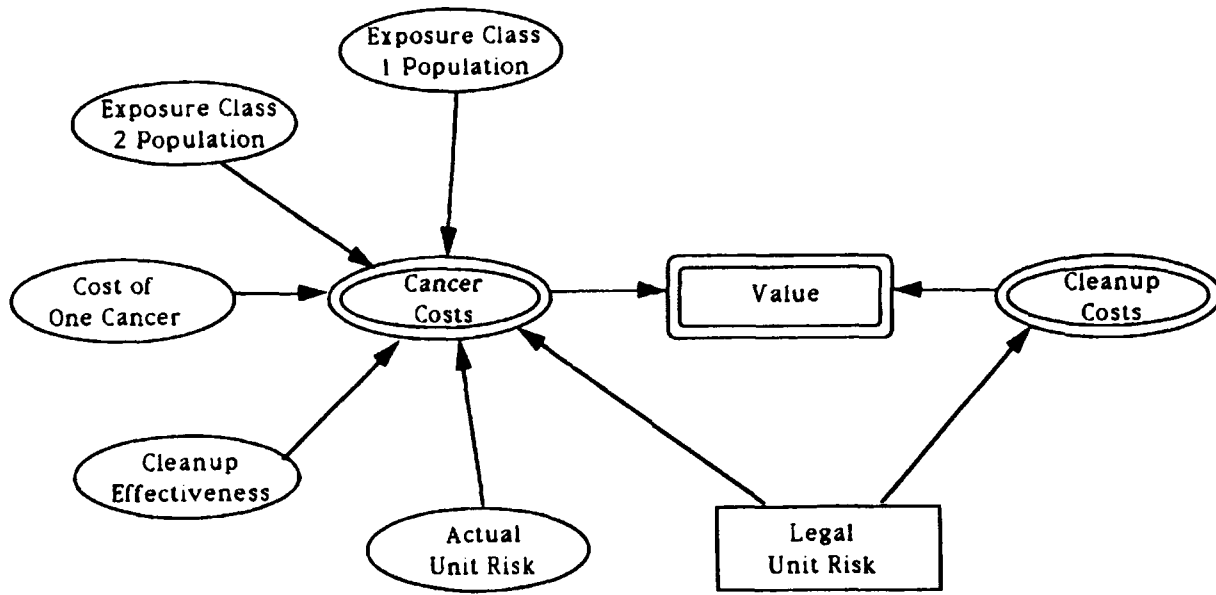


Figure 2. Results of the Deterministic Sensitivity Analysis.

We will represent our decision model in the stochastic phase as an influence diagram. The influence diagram is a graphical modeling tool for the formulation and analysis of stochastic decision models [3]. Several software packages exist for automated analysis of an influence diagram. The graph of the influence diagram provides important information to the user and to the computer algorithms about dependencies and information flow in the model. Associated with each node is a frame of data such that the influence diagram is a complete description of the model. In analyzing influence diagrams the data and the graph work together in what has proven to be a very effective combination.

Setting up the influence diagram with the six variables in it produces the model illustrated in Figure 3. We can read this influence diagram as follows. The single decision variable is Legal Unit Risk, the unit risk number to be assigned by the EPA. The objective function is Total Costs and is a function of Cancer Costs and Cleanup Costs, their sum. Cancer Costs in turn is a function of Exposure

Class 1 Population, Exposure Class 2 Population, Cost of One Cancer, Cleanup Effectiveness and Actual Unit Risk. Cost of One Cancer is a constant to be set by the user. The other four predecessors of Cancer Costs are random variables. Each of these will have a set of outcomes and a probability distribution over those outcomes stored with the node on the computer. The other predecessor of Total Costs, Cleanup Costs, is a function only of Legal Unit Risk.



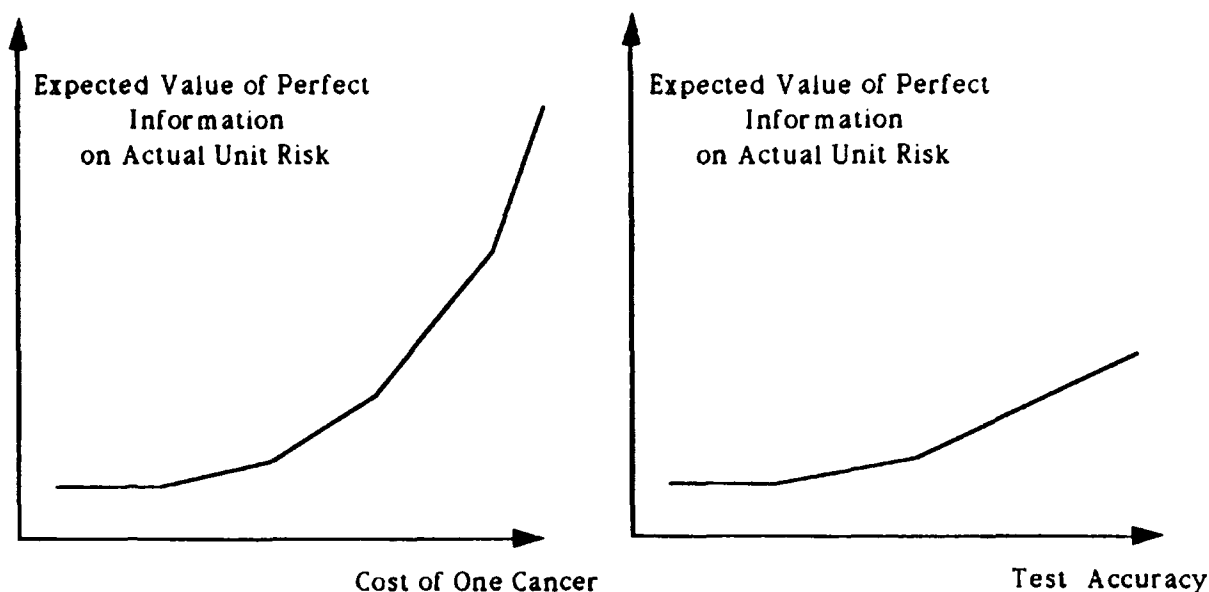
**Figure 3. Influence Diagram Formulation of the Decision Mode.**

The variables that were not significant enough to include in the influence diagram were set to their nominal values. Thus they are still in the model, but implicitly.

The influence diagram model can now be solved for the optimal setting of Legal Unit Risk. We also can perform value of information calculations at this point. When the EPA or any organization is faced with making a decision under uncertainty, as in this case, it is very natural for them to consider various information gathering activities to reduce the uncertainty in the problem and so make a better decision. A strong advantage of the decision analysis framework is that a decision model such as ours can be analyzed to find a dollar value for reducing the uncertainty in the various random variables in the model either completely or partially. The two graphs in Figure 4 provide examples of the type of results that can be obtained by way of value of information calculations.

Figure 4a shows the expected value of perfect information (EVPI) on actual unit risk. This graph shows the expected value of reducing all uncertainty in the Actual Unit Risk. This corresponds in the influence diagram in Figure 3 to adding an arc from Actual Unit Risk to Legal Unit Risk, indicating that the decision-maker knows the value of Actual Unit Risk before the Legal Unit Risk

assignment must be made. Note that this provides us an upper bound on the value of any testing we might do to find out the toxic hazard posed by the chemical. No test for determining the unit risk of DCM could ever be more valuable than the EVPI for that variable. We have plotted the EVPI for the unit risk as a function of another variable in the model, Cost of One Cancer. We would expect that as the decision-maker assigned a higher and higher value to the Cost of One Cancer, the EVPI on Actual Unit Risk would increase.



**Figure 4. Example Output of Value of Information Calculations.**

The decision analysis framework and the influence diagram software also provide us the ability to calculate the expected value of imperfect information; that is, the expected value of a real world test. To do this we must provide information on the quality of the test. This is done through a set of probabilities that describe the outcome of the test given the actual value of the variable of interest, in this case, Actual Unit Risk. With this information and our prior probability distribution for Actual Unit Risk we can solve the influence diagram decision model for the expected value of a test on Actual Unit Risk. A test on Actual Unit Risk would be incorporated into an influence diagram as a node with Actual Unit Risk as a predecessor (the outcome of the test depends on Actual Unit Risk; that is why it has value) and Legal Unit Risk as a successor (the decision-maker will know the outcome of the test before the decision is made). The results of such calculations might look like the graph in Figure 4b. Note that we have plotted the expected value of information on Actual Unit Risk as a function of test accuracy.

We feel that these value of information calculations are a very important contribution to the assigning of unit risk values for hazardous chemicals. The EPA is essentially faced with the situation of

paying out money to pay for testing to reduce the uncertainty in the unit risk for a hazardous chemical. Value of information calculations can answer two very important questions for the EPA. First, what is the maximum amount that the EPA should be willing to spend on testing a chemical? Second, what is the value of a specific test proposed to the EPA?

What we have presented so far is what we feel is an effective, comprehensive framework for the consideration of the problem of assigning unit risk numbers to hazardous chemicals. We feel that there are three advantages to this framework which we have demonstrated. First, we believe that modeling the problem in this way makes explicit the rationale and assumptions behind the assignment. This helps the decision-maker to understand the problem better, to be more confident in assigning the unit risk number, and it provides the decision-maker a basis for defending the resulting assignment. Second, we believe that the concept of exposure classes provides a very promising, clean way to consider the problem. Finally, the value of information calculations made possible by the decision analysis framework and the influence diagram have the potential to answer the dominant questions that the EPA must answer when considering the unit risk for a hazardous chemical.

The sensitivity analyses and value of information calculations performed in the decision analysis provide information on what the most important random variables are in the model. For this specific case, it is clear that one of the most important random variables is Actual Unit Risk. It is thus important to establish an accurate probability distribution for this random variable. There are generally three ways of doing this. First, we could directly assess the probability distribution from an expert or perform a statistical study to establish the probability distribution. This is the direct method. Second, we could use Bayes theorem to combine a prior distribution on Actual Unit Risk with evidence from some test. Third, we could decompose Actual Unit Risk into its various assumptions. This is the approach taken in the remainder of this paper.

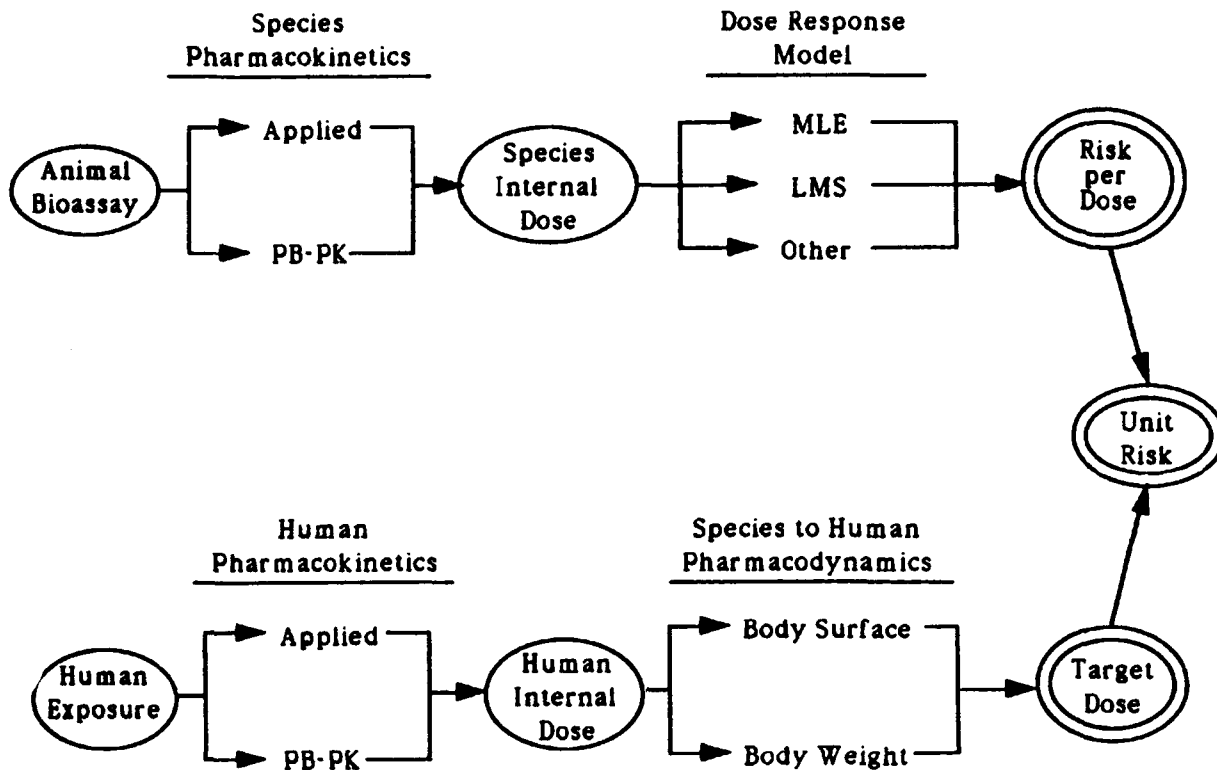
## **DECOMPOSITION METHOD**

### ***Unit Risk Assessment Flowchart***

There are a variety of ways of determining the risk of a carcinogen. The unit risk number assessment flowchart is shown in Figure 5. The first step in assessing the unit risk number for any suspected carcinogen is to conduct a bioassay to determine the effect it has upon animals. The next step is to calculate the species' internal dose. This is calculated in one of two ways: using the applied dose technique or the PB-PK model. The risk-per-dose is then obtained by taking the bioassay results and the species internal dose and putting them into a dose response model. One of these dose response models is the linearized multistage (LMS) model which provides a 95% lower confidence limit (LCL) on dose at a fixed risk. The LMS model has been commonly used by the EPA because it provides a conservative (health-protective) estimate of risk [4,5]. Another method uses the maximum



likelihood estimator (MLE) for dose instead of the 95% LCL. There are also other dose/response models such as one hit, multihit, probit, and Weibull [6].



**Figure 5. Chemical Risk Assessment Flowchart.**

The human internal dose is calculated much the same way as the species internal dose, either using the applied dose technique or the PB-PK model. The human internal dose is multiplied by the species-to-human pharmacodynamics correction factor to get the target tissue dose. There are two common interspecies correction factors based on dose per unit body weight and dose per unit body surface. The body surface internal dose is approximately 12.7 times larger and will make the unit risk number of a chemical 12.7 times higher than if calculated using the body weight method when extrapolating from mouse to human.

After obtaining the animal's risk-per-dose factor and human target dose, the unit risk number for a given exposure can be determined.

**Combination of Methods for Unit Risk (Tree Diagram)**

There has been much controversy on the appropriate method for determining the unit risk number of a chemical. Any policy put forth that suggests a specific unit risk number for a particular chemical is usually criticized for some of its assumptions. There is always someone who disagrees on

how the assumptions were made or what techniques were utilized. In a majority of cases, the unit risk number is developed using a combination of the most likely, and sometimes most conservative, assumptions for a given chemical and effect. The problem with this approach is that other assumptions, even though less likely, are not considered in the final unit risk.

Some methods have assumed humans to be more sensitive to the tested chemical than the lab animals (body surface method). This may not always be true [7]. Some methods, when extrapolating from high dose to low dose (dose response models), ignore the possibility that below a certain threshold level the chemical may pose no risk of cancer at all. In addition, bioassays are performed exposing the animal to contaminated air, food, and water, for which the concentrations are known (external factors), and the internal tissue concentrations of the chemical are based on these external concentrations and the animal's breathing rate or food consumption. The chemical is assumed to be completely absorbed into the animal's body, which completely neglects the physiological aspects of the body in dealing with the chemical [8].

If all potential assumptions, from the various risk methods, could be weighted according to their perceived ability to estimate the unit risk number, then a weighted average of unit risk could be determined, where the weights reflect the decision-maker's belief in each assumption's ability to determine the unit risk accurately. The assignment of the unit risk number then could take on the form of a tree diagram with the branches representing each potential assumption; at the end of the branches are the unit risk numbers for the various combinations of assumptions. Thus, all arguable combinations of assumptions could be considered in obtaining the unit risk.

#### ***PB-PK Model of Combinations (Tree Diagram)***

According to the EPA [9], the PB-PK predictive model of Clewell and Andersen for DCM did not take into consideration several alternative ways of predicting DCM's unit risk number, such as the chemical using a different pathway to affect the body's tissues. Also the PB-PK model did not allow for uncertainty of its parameter values. So, the PB-PK branch is further divided into additional branches which allows those alternatives to be included in the assessment process and to be weighted as to their ability to predict the unit risk. Thus, by varying the parameter values, the uncertainty in which value to use can be addressed, and a much broader and more believable approach can be generated for determining the unit risk number.

The various ways of obtaining a unit risk number can be decomposed into different assumptions, and a tree diagram can be generated. The tree diagram allows the decision-maker to focus on each assumption and assign a weight as to his belief that the assumption will aid in providing a realistic risk, and then a weighted average of unit risk can be obtained.

The National Toxicology Program's (NTP) inhalation bioassay [10] found that DCM caused cancer in mice. With only one bioassay used for analysis there is no need for a bioassay branch within the DCM tree. Also, there is no need for a dose response branch because only the LMS dose response model has been used by federal agencies in determining unit risk number for DCM. Figure 6 contains the major assumptions employed by federal agencies in determining a unit risk number for DCM, and it is divided into three sections: (1) species pharmacokinetics, (2) pharmacodynamics, and (3) human pharmacokinetics. The PB-PK branch of Figure 6 is defined further by taking the mouse and human pharmacokinetic models and dividing them into several PB-PK variables, as shown in Figure 7. The PB-PK portion of the DCM tree is divided into pathway and biochemical constants (metabolic constants and kinetic constants). The metabolism of DCM may occur via two pathways: (1) "one dependent on oxidation by mixed function oxidases (MFO) and the other dependent on glutathione S-transferases (GST)," [11] or (2) DCM could act directly on the tissues of concern. Thus the tree is broken into three additional assumptions regarding the chemical mechanism responsible for causing cancer: GST pathway, MFO pathway, or DCM directly. The biochemical constants are divided further into A1 and A2, relative activity ratios of lung enzymes to liver enzymes in the MFO and GST pathways respectively;  $K_f$ , first-order rate constant for metabolism of DCM by the GST pathway in the liver;  $V_{max}$ , the maximum velocity of metabolism by the MFO pathway in the liver.

The choice of limiting the biochemical constants to the four listed above (A1, A2,  $K_f$ ,  $V_{max}$ ) was made by Andersen [12], who provided the range of values, which are shown in Table 1. All other PBPK values, other than A1, A2,  $K_f$ , and  $V_{max}$ , are set to nominal values [11].

### ***Assigning Preference Weights***

The two DCM tree diagrams were provided to Andersen for assigning preference weights to each branch. These weights are based on his belief of the correctness of each assumption in estimating the unit risk number, and are shown in Figures 6 and 7.

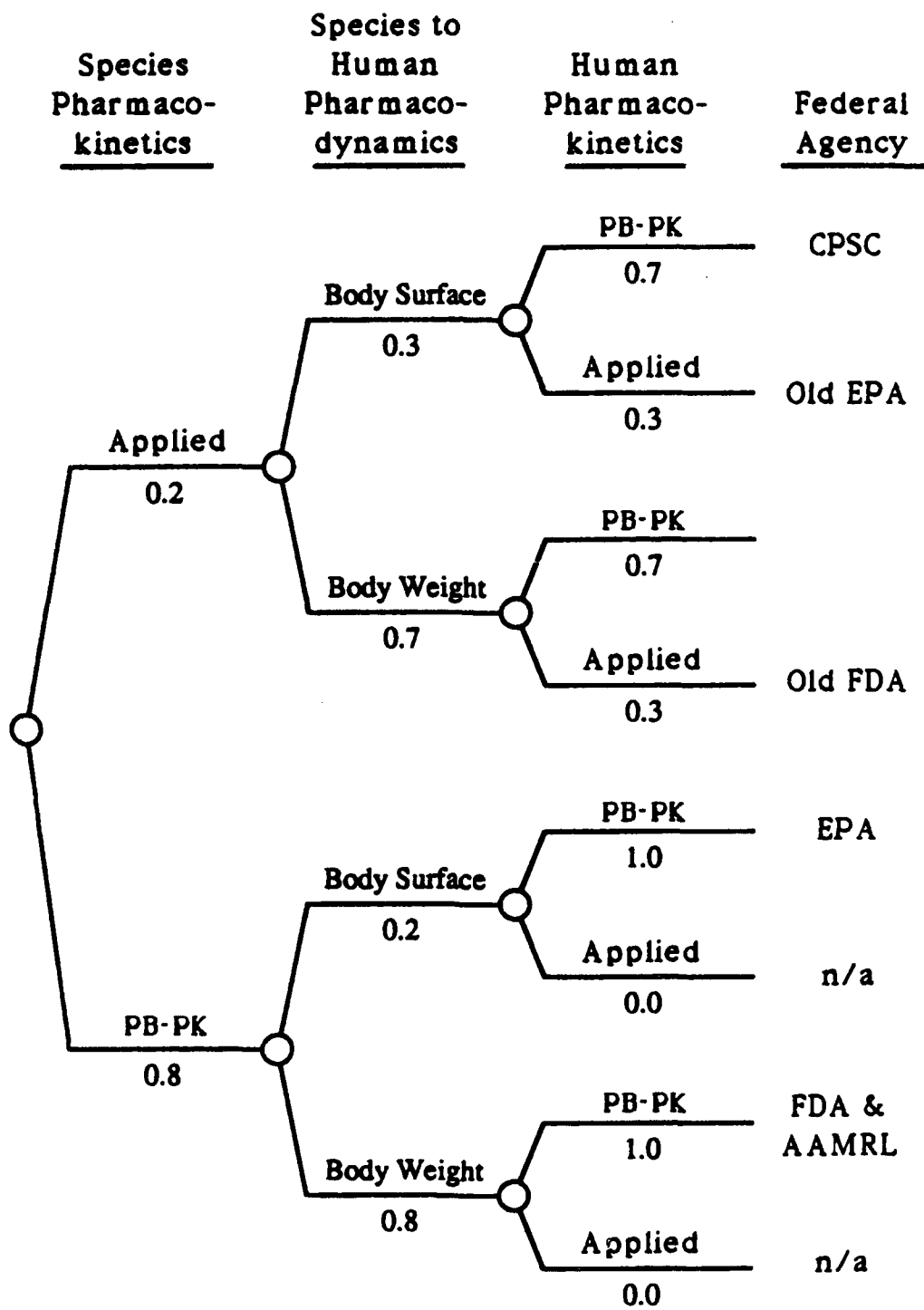


Figure 6. Methylene Chloride (DCM) Tree Diagram.

### PB-PK Stochastic Sensitivity Analysis

The DCM tree as shown in Figures 6 and 7 creates 6546 combinations for obtaining the unit risk number. Of the 6546 combinations of assumptions for determining the unit risk number, all but two (6544) are combinations using PB-PK models. If any of the PB-PK variables could be set to their nominal values (fixed), this would reduce the number of unit risk number calculations required. So a stochastic sensitivity analysis of the PB-PK variables in Figure 7 was performed in order to determine the least important variables and hopefully decrease the number of variables in the PB-PK tree. The stochastic sensitivity analysis indicates how the weighted average of unit risk depends on a particular assumption when the other assumptions are taken with their assigned weights.

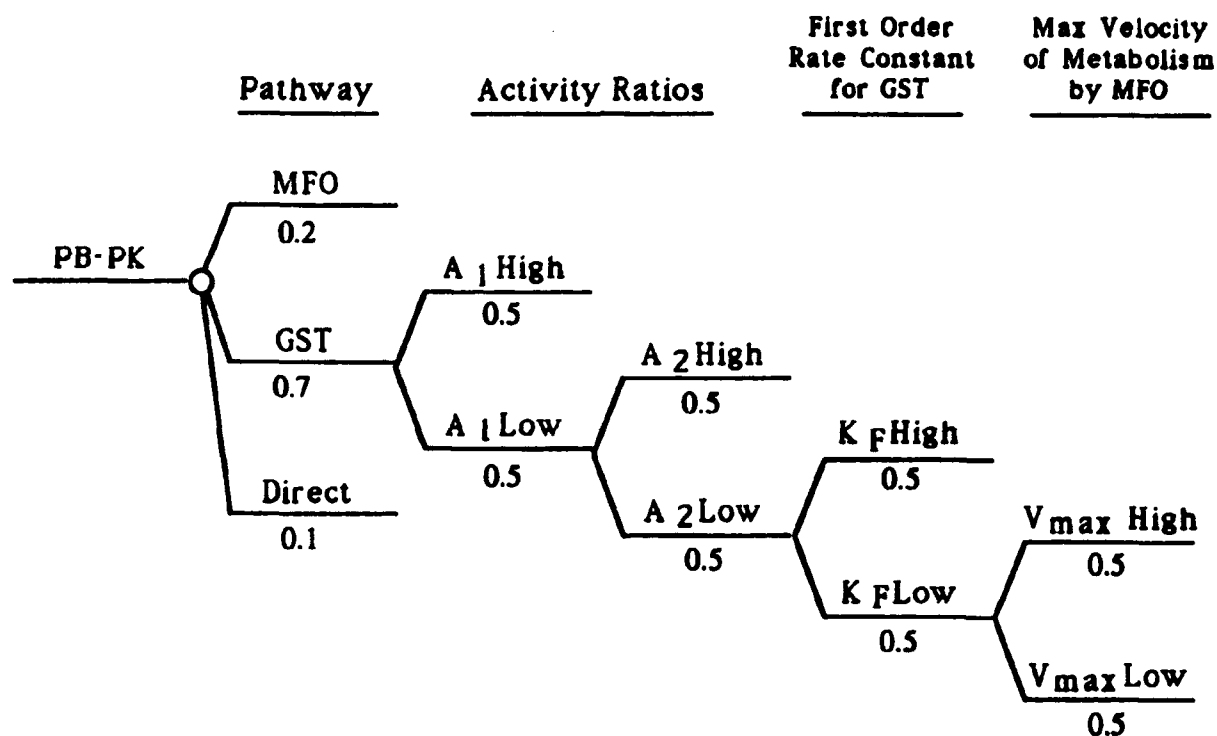


Figure 7. PB-PK Variable Tree Diagram for Human and Animal.

The PB-PK model developed by Andersen and Clewell was used to generate the dose surrogate values for both mouse and human. The mouse dose surrogate values were used in the LMS dose response model, along with the NTP bioassay results for mice, to obtain the parameters for the dose response model. Then these dose response values were multiplied by the human dose surrogate values (target dose) to get the unit risk numbers. The range of unit risk numbers for the stochastic sensitivity analysis is shown in Figure 8 [13], and shows that the PB-PK variables (A<sub>1</sub>, A<sub>2</sub>, K<sub>f</sub>, and V<sub>max</sub>) make very little difference between their high and low values on the unit risk number as compared to the pathway assumption. For pathway, the range between the high and low unit risk numbers is significant, approximately 397 times larger than the unit risk range for variable A<sub>1</sub>. Therefore the

unit risk number is very sensitive to which pathway assumption is used (MFO or GST) and is not nearly as sensitive to the other four variables. Thus the PB-PK variables A1, A2,  $K_f$ , and  $V_{max}$  were set to nominal values as listed in Table 1.

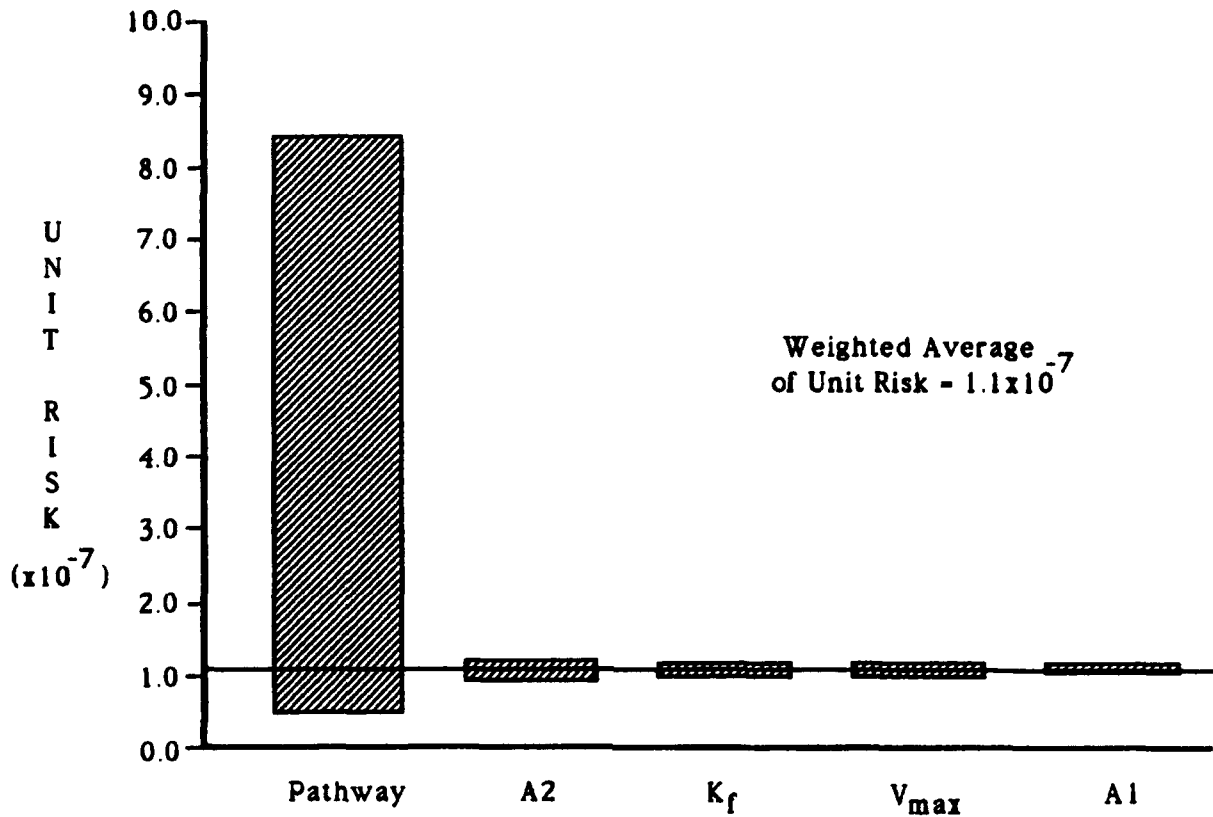


Figure 8. PB-PK Stochastic Sensitivity Analysis.

TABLE 1. PB-PK VARIABLES' RANGE\*

Species	Variable (units)	Low	Nominal	High
Mouse	A1 (ratio)	0.276	0.405	0.560
	A2 (ratio)	0.196	0.280	0.377
	$K_f$ (1/h)	3.000	4.000	5.000
	$V_{max}$ (mg/h)	0.900	1.054	1.200
Human	A1 (ratio)	0.000	0.001	0.004
	A2 (ratio)	0.148	0.180	0.297
	$K_f$ (1/h)	0.320	0.430	0.640
	$V_{max}$ (mg/h)	85.000	118.900	150.000

\* Andersen, 1988 [12]

### Reduced Methylene Chloride Tree

With the four PB-PK variables removed from the tree, it reduces to that as shown in Figure 9. The unit risk numbers associated with each combination of assumptions have been determined [13], and the weighted average of unit risk is calculated by converting the unit risk numbers for each

combination to logarithms and folding back the tree using the preference weights, which gives an unit risk number of  $2.1 \times 10^{-7}$  for a continuous exposure to  $1 \mu\text{g}/\text{m}^3$  of DCM.

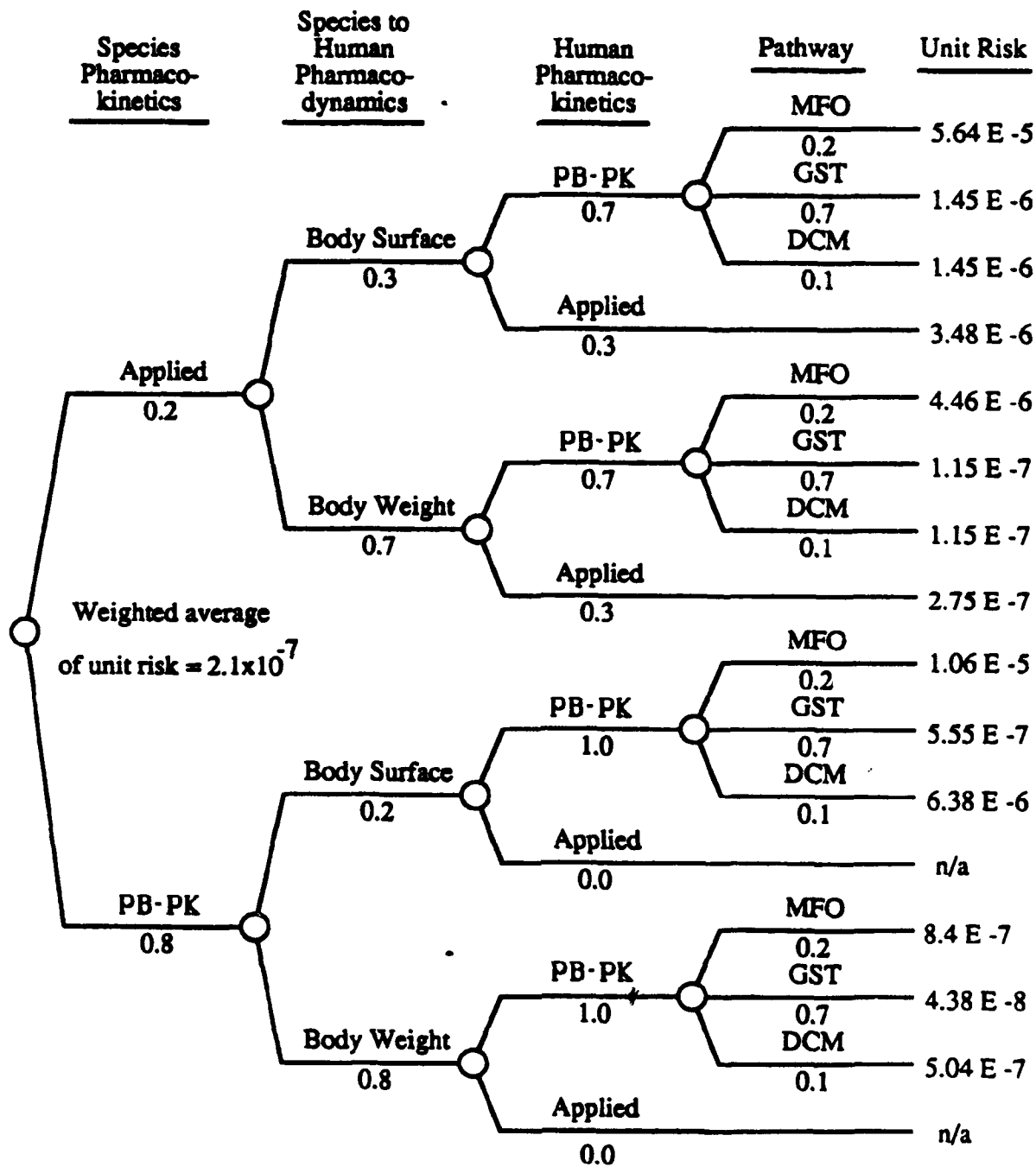


Figure 9. Reduced Methylene Chloride Tree Diagram.

### Unit Risk Distribution for DCM

The unit risk distribution for DCM is shown in Figure 10. The weighted average is dominated by the weights assigned to the PB-PK-body weight-GST assumption combination. Almost 45% of the weighted average is influenced by this combination. If the decision-maker believes the PB-PK-body weight-GST combination should not have this much influence over the weighted average, than he is free to re-evaluate the unit risk number using new preference weights. In this way the decision-maker can easily analyze his unit risk number and how it was obtained.

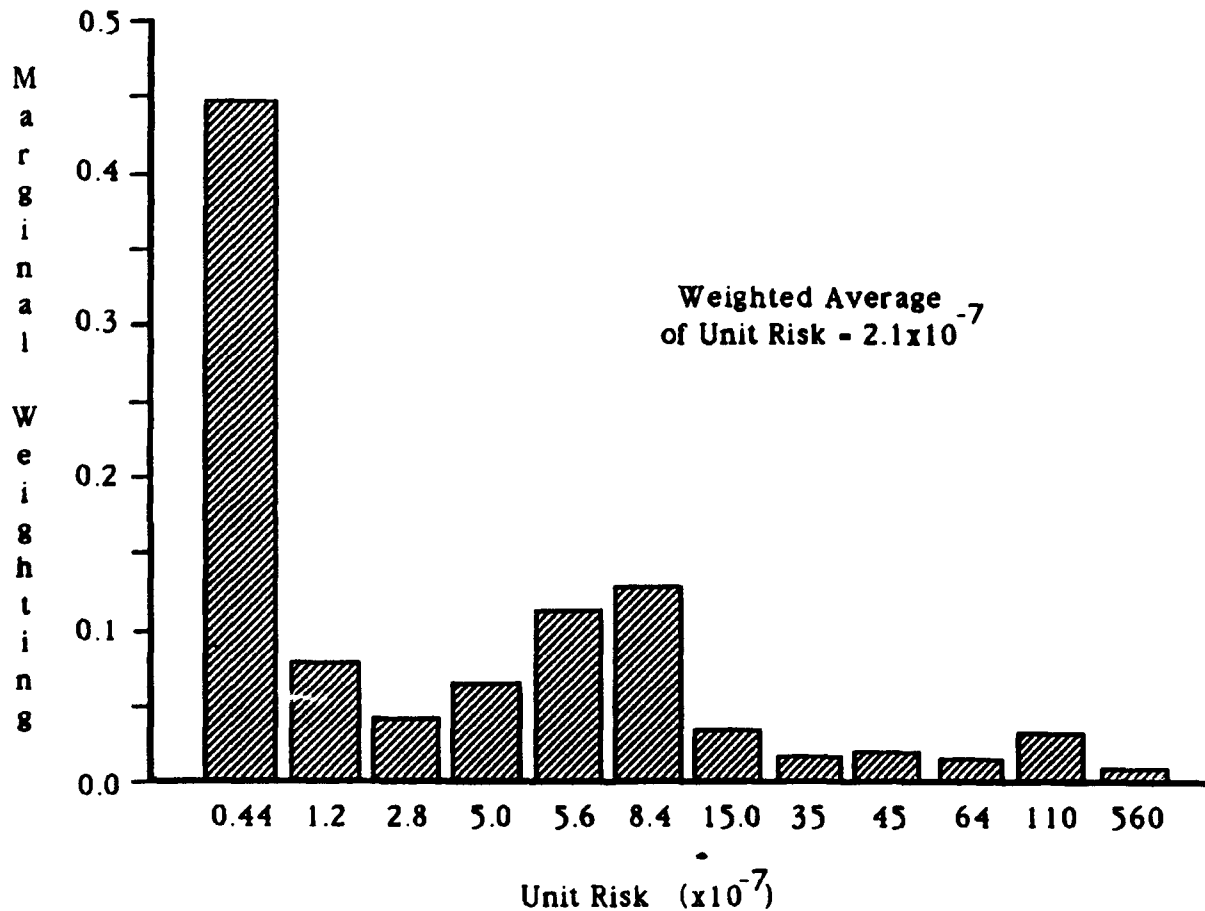


Figure 10. Unit Risk Distribution for DCM.

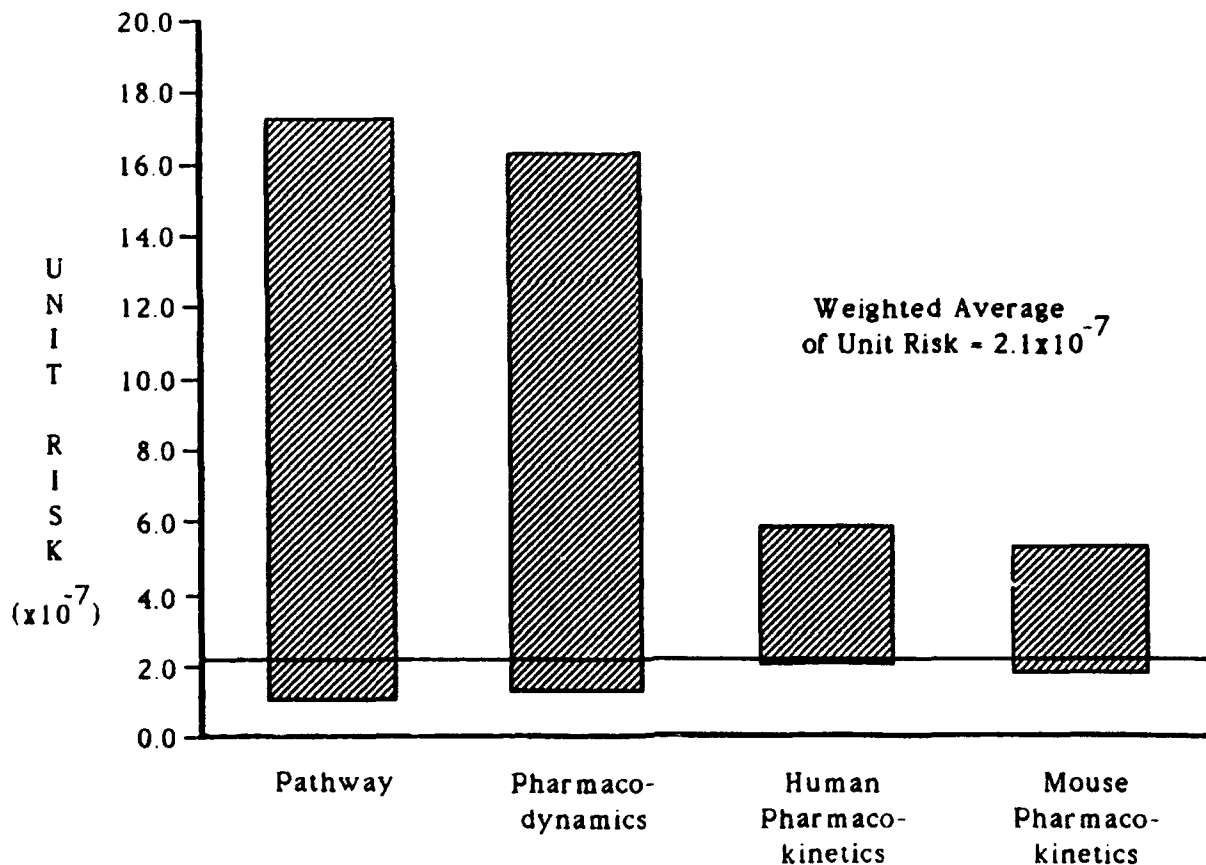
### DCM Unit Risk Stochastic Sensitivity Analysis

Like the variables in the PB-PK tree, the DCM tree can have a sensitivity analysis performed on its assumptions to observe how much they affect the weighted average. A stochastic sensitivity analysis was performed on the DCM tree and the results are shown in Figure 11 [13]. Of the four assumptions, pathway still influences the weighted average more than the other three, but not as significantly as it did in the PB-PK tree where it significantly dominated the four PB-PK variables (4.46



times larger range as compared to 397). Hence, the four assumptions, pathway, pharmacodynamics, human pharmacokinetics, and mouse pharmacokinetics, are important in the unit risk assessment process, at least for DCM given Andersen's preference weights.

The unit risk number of DCM for a continuous exposure to  $1 \mu\text{g}/\text{m}^3$  was found to be  $2.1 \times 10^{-7}$  via the decomposition method. Even though the  $2.1 \times 10^{-7}$  seems like a good unit risk number it is not a recommendation, but rather an example to illustrate the decomposition method for determining the risk associated with chemicals. The PB-PK variables  $A_1$ ,  $A_2$ ,  $K_f$ , and  $V_{\text{max}}$  do not make much difference, but the PB-PK pathway, pharmacodynamics, human pharmacokinetics, and mouse pharmacokinetics are significant. This study indicates that scientific efforts should be concentrated on analyzing the significant assumptions because the uncertainty of these play a larger role in the variance of the unit risk number.



**Figure 11. DCM Unit Risk Sensitivity Analysis.**

The decomposition method can be applied when evaluating the unit risk number of DCM. This method incorporates several common methods for determining the unit risk of DCM whereas the EPA's unit risk is developed from only one combination of assumptions. The decomposition method

ranks each assumption as to its ability to predict the unit risk of the chemical while incorporating the most current information available to the toxicologist.

## CONCLUSIONS

There are various ways of determining the risk of a chemical. The different federal agencies responsible for setting chemical risk standards are not in complete agreement. Overestimating the risk places a financial burden on industry for maintaining the standard, and underestimating the risk puts society in jeopardy of a greater health threat. This study has shown how the different risk assessment methods can be decomposed into their assumptions; these assumptions are then evaluated for their ability to estimate the risk of a chemical accurately. Then the weighted assumptions are recomposed into a weighted average of risk. This method incorporates several acceptable unit risk methods into one larger and more thorough process instead of just relying on one method, which may ignore the uncertainty associated with its assumptions. In doing so, the significance of the assumptions and variables that are used can be appraised and compared. Finally, a weighted distribution of the unit risk number can be generated for providing a better understanding of how the unit risk number was obtained and the possible range of values.

The decomposition method aids the decision-maker in better understanding the chemical in question. By addressing the various assumptions used for determining the unit risk number, the decomposition method forces the decision-maker to place a likely range of values and preference weights on the assumptions. In doing this the decision-maker deals with the uncertainty of each assumption with the hope of obtaining a realistic and acceptable unit risk number.

## ACKNOWLEDGMENTS

The authors acknowledge very helpful discussions with Dr Melvin Andersen and Lt Col Harvey Clewell of the Armstrong Aerospace Research Laboratory, Toxic Hazards Division, Wright-Patterson AFB, OH.

## REFERENCES

- 1 Clewell, H.J. and Andersen, M.E. (1985) Risk assessment extrapolations and physiological modeling. *Toxicol. Indust. Health* 1, 111-131.
- 2 Howard, R.A. and Matheson, J.E. (Eds.) (1983) *The Principles and Applications of Decision Analysis*. Menlo Park, CA.
- 3 Shachter, R.D. (1986) Evaluating influence diagrams. *Opns. Res.* 34, 871-882.
- 4 Munro, J.C. and Krewski, D.R. (1981) Risk assessment and regulatory decision making. *Fd. Cosmet. Toxicol.* 19, 549-560.

- 5 Environmental Protection Agency (1987) A Cancer Risk-Specific Dose Estimate, EPA-600. Washington, DC.
- 6 Hanes, B. and Wedel, T. (1985) A selected review of risk models: One hit, multihit, multistage, probit, Weibull, and pharmacokinetic. JACTDZ. 4, 271-278.
- 7 Calabrese, E.J. (1987) Animal extrapolation: A look inside the toxicologists black box. Environ. Sci. Technol. 21, 618-623.
- 8 Menzel, D.B. (1987) Physiological pharmacokinetic modeling. Environ. Sci. Technol. 21, 944-950.
- 9 Environmental Protection Agency (1987) Update to the Health Assessment Document and Addendum for Dichloromethane (Methylene Chloride): Pharmacokinetics, Mechanism of Action, and Epidemiology, EPA/600/8-87/030A. Washington, DC.
- 10 National Toxicology Program (1986) NTP Technical Report on the Toxicology and Carcinogenesis Studies of Dichloromethane in F344/N Rats and B6C3F<sub>1</sub> Mice (inhalation studies), NIH 86-2562, NTP TR 306. Washington, DC.: U.S. Department of Health and Human Services, Public Health Service, National Institutes of Health.
- 11 Andersen, M.E., Clewell, H.J., III, Gargas, M.L., Smith, F.A. and Reitz, R.H. Physiologically based pharmacokinetics and the risk assessment process for methylene chloride. Toxicol. Appl. Pharmacol. 87, 185-205.
- 12 Andersen, M.E. and Clewell, H.J. Personal Interviews. Toxic Hazards Division, Armstrong Aerospace Medical Research Laboratory, Wright-Patterson AFB, Ohio: April and May 1988.
- 13 Clement, D.S. (1988) Dealing With Uncertainty in Chemical Risk Analysis. Masters Thesis, Air Force Institute of Technology, Wright-Patterson AFB, OH.

**ESTIMATING UNCERTAINTY**

Christopher J. Portier

*Biometry and Risk Assessment Program, NIEHS,  
P.O. Box 12233, Research Triangle Park, NC 27709*

*(Manuscript Not Submitted)*

## SESSION V

### PANEL DISCUSSION

**Dr Ray Yang (NIEHS):** I want to say something in regard to Dr Allen's talk. At the end, Dr Fred Miller from EPA made a point that is extremely important in terms of the gross factor in the age-related changes in pharmacokinetic analysis. I want to second his feeling and I want to, in fact, strongly endorse that particular aspect of it. I think it is not uncertainty. It is a fact that as animals, including humans, grow older that the disease stage, the physiological stage, changes in such a way that it definitely will affect the pharmacokinetic behavior of a chemical. I want to specifically mention that at NIEHS we have initiated an effort of looking at methylene chloride. We are not doing a repeat of the bioassay study, but we are doing a chronic study in which we will look at oncogene effect and also cell turnover rate. The former is headed up by Marshall Anderson, the latter is headed up by Frank Currie and Bob Marinpoe. There is a third component of that is physiologically based pharmacokinetics. Along the line of this chronic study, we will take one day, one month, twelve months, and twenty-four months and more to do the gas uptake study advanced by Mel Andersen and Kilser and also do enzyme analysis of the P-450 and GST system. We will also do all the partition coefficients for these particular stages. And I have a lot of good colleagues to work with. In fact we are working very closely with Mel Andersen and Harvey Clewell, Mike Gargas, and Dick Reitz at Dow. My colleague Chris Portier is also interested in, later on, participating in this effort when we get our data and so on. So, I think something like this is going to be very important to allow the maturing of this whole approach.

**Chris Portier:** Did I answer your question, Harvey? Your question earlier, did I answer it about the variability of EPA's analysis as compared to yours and what is the additional variability?

**Clewell:** Yes, thanks. I guess the answer is not right, but I think I understand now. I actually wanted to thank Chris myself for clarifying for me a new paradox I have just discovered, which is that there is uncertainty in our uncertainty estimates and it is kind of like sitting in the barber chair and you are looking in the mirror in front of you and see your reflection in the mirror behind you, which has the reflection of the mirror in front of you, which contains the reflection of the mirror behind you. So now, there is probably uncertainty in our uncertainty about the uncertainty in the parameters as well. But, thanks also for that marvelous last, final comment on the two-stage model and different ways of looking at it. That was an extremely useful concept. That really is an important thing to try to clarify again, to look at the implications of the way people are using the two-stage model and could use it. Regarding this uncertainty, there has never been a meeting I have gone to that I have not wanted to show the slide that Kenny Crump made of the animal-based estimates of cancer risk or safe dose

versus the human-based estimates of safe dose for a large number of carcinogens. It shows a very nice correlation. Of course, it is eleven-cycle log paper so it demonstrates that it looks really good until you try to see; something can be off two orders of magnitude and look like it is right next to the line of best fit. It was good news that things that are more potent in animals seem to be more potent in humans, but it also exemplified the fact that there is an awful lot of uncertainty. We do not know exactly where true is. I think several people today have highlighted the fact that a real problem in this business is that you do not have the "true" to do the comparison with like you can try to get in some cases. But, anyway, all that leads up to my question. I do not think there is anything I have seen more confusion about in the risk assessment community than why people use linearized multistage (LMSs) models, and actually I think it was Chris who clarified it for me once when I was at the NIEHS. He said it accounts for uncertainty as to the proper model to use for extrapolating the low dose and does not incorporate a lot of other uncertainties. But, as we get more and more into this two-stage model and other potential or possible models for carcinogenesis, people are getting more and more this notion that maybe we could replace the LMS model once we know more about what is going on, and I guess my question is, is that true? I mean, what do you need to know to replace the LMS model? Do you need to have a good estimate of the actual values of parameters, sensitivities, etc., in the human population, as well as the various different mechanisms at low dose and uncertainty in the bioassay? Do we want to replace the LMS and what would be necessary to know in order to replace it?

**Farland:** I can start off. It is a tough question. I think everything that I suggested that we might be doing in terms of research is really directed toward that question. No one is pleased with the idea of trying to come up with just a plausible upper-bound on the risk, and I use that term "plausible" to mean, this is a plausible upper-bound if we really knew more about the data we might find occasions where it was not the true upper-bound on the risk and did not represent the true risk very well, and I think that Chris would agree with me on that. The point that I would make, I think, is that the way we are going in the development of models these days and an understanding of the data that is necessary to feed into those models in order to use them is going to point to a cliché that I am fond of using these days, "evolution rather than revolution." We are not going to replace one model with another model immediately. We do not know enough about the biology that is behind these in order to be able to suspect that in just a few years we will be able to replace our current approaches completely. But, I think what we will do is evolve to the point where we will use these alternative approaches, we will understand more of the uncertainties associated with those approaches and the uncertainties associated with the current approach, put those in perspective, and eventually move closer toward some estimate of what you might have called the truth.

**Portier:** If I might make a brief comment on that. Mathematically, which is the way I can speak about it, we will make a comparison between the two-stage model of Moolgavkar and the LMS model. The only way that you would ever conceivably want to get rid of the LMS model is in the situation where you believed that the probability of getting a cancer was solely due to the proliferation effect in the cells of increased cell growth and in no way, no way at all, due to a mutation effect, specifically, a linear mutation effect. If you can rule that out, theoretically, then, in fact, you would have to rule out the LMS model. If, on the other hand, you believe there is a little bit linear effect on mutation rates, then even if you go with the Moolgavkar model, you are going to get virtually identical lower-bound risk estimates on the safe dose. So, mathematically, that is what is going to happen. The bottleneck is the animal bioassay data. There is a tremendous amount of variability in animal bioassay data. And, unless you are willing to go to supersize, megamouse studies, you are not going to be able to reject the concept of linearity in favor of nonlinearity with the studies that we have. In fact, even when we have gone to megamouse studies, we have had problems with rejecting it. So it is not at all clear you can even do that.

**Farland:** That is a hell of a lot of data. Again, I think you are looking at this from the standpoint of what does it take to get consensus from the scientific community that you have amassed enough information that this is a reasonable estimate of risk. I mean, the difference between the way that we in the regulatory community do business and the way that the legal community does business is that they can find an expert on either end of the spectrum, use them, and let the judge make the decision. We, on the other hand, are faced with trying to develop some sort of scientific consensus, bring the scientists together to say that this is a reasonable approach and we think we have got enough information to make that sort of a statement. So, what we are looking for right now is scientific consensus on both the approaches for collection of data and the application of the data to these multistage models, two-stage model, at least, that have been proposed that would accommodate those data.

**Wilson:** Let me elaborate on that just a little bit. I think that one thing that we can hope to do is, by getting data on influence of treatment on mitotic rate increase or net cell birthrate increase, we can identify dosing regimes where both types of stimuli are operative and try to get at just a mutagenic effect, which is the one we are bound to be most concerned about at low exposure. In the megamouse EDO-1 experiment, which Chris referred to, in the bladder there is a very clear distinction. You can break those data into two regimes, and using low-dose data gives probably what is a very good estimate of the very low exposure risk for those animals in that case. But that is more data than we are typically going to have available. What we did like to be able to develop is methods to get at some estimate of how much of the mitogenic contribution to the high-dose incidence.

**Portier:** One quick comment here. I do want to point out that I have to thank Harvey, Mel and Suresh for actually providing us with situations where we can think about this concept and look at what we should be looking at to make these sorts of decisions. That is exactly what they have done with the models that they are proposing to us. And I think it is very important that we recognize the fact that they have done that for us.

**Clewell:** Thanks. I am very comfortable with all those answers. That is great. Now, there is one thing I still am trying to clarify in my own mind. I have sensed in the community a lot of confusion between what the multistage model does when you end up with a  $10^{-6}$  risk, and the impact of heterogeneity in the human population and subpopulations. When I talk to other people they all think that, well all we have to do is measure the actual glutathione activity in the human population and know how many people were sensitive. Are you clear on what you do if, in some future time, we do know something key about the sensitivity of the human population to fold that in and still end up with a  $10^{-6}$  risk when you have subpopulations, and sensitivity differences, etc. Is that a totally separate issue that is easy to work into this  $10^{-6}$  risk calculation using the multi-stage model on an animal bioassay?

**Portier:** I think if you knew that much information you would stop using the present approach to estimating the risk. You could go to something that is more population-specific and allows you to make some estimate of the probability that you get any injury in the particular population at risk which you could then do, given big enough computers and enough data. It is a different question though, Harvey.

**Dr Fred Miller (EPA):** I have two quick comments. Well, one is quick and the other may not be so quick. The assumption of equal response across species, we seem to be focusing on carcinogenic endpoints. And, in terms of the risk assessments that are required as you go to noncancer endpoints, I think that assumption becomes less and less tenable and that you have to incorporate not only dose but species sensitivity because of different aspects in these other endpoints, be it behavioral or reproductive, etc., that may in fact further complicate the problem. That is a quick comment. The other is a comment directed to Dr Portier. We are almost uncovering here a statistical paradox in the sense that when we did our bioassays and we assumed in ignorance that we were going to use what they were exposed to, and that was a dose measured without error, and yet those of us who have been doing a little bit of deposition work knew that for a particulate, for example, in the cadmium work, we were off by a factor of 14 because the rats only retained 7% of that, and yet we assume without error that they had 100% uptake of the dosage. We are getting a double whammy because we are not allowing that to introduce error in your analyses on the one hand, but yet, when the PB-PK models come along, which actually do a much better job of estimating what is the delivered dose, now we have to assume that there is error in that and now our distribution of uncertainties of all the



analyses that we do seem to further complicate matters to the point that we do not agree on what is the final endpoint. In one sense we should not cast aspersions upon the previous way of doing it without almost being obligated to come up with some way of assuming, in fact, that now when we have gotten the population estimate by the PB-PK model, can we assume that is without error? I mean, otherwise, you are always going to broaden the uncertainty and have more and more disagreement about what is the risk when, in fact, these models should help us focus on narrowing that uncertainty. That is why I call it an apparent paradox.

**Portier:** I have two answers to that. The first answer is the same one Bruce gave and that is that we were doing it wrong before and not to do it right, now, is still to do it wrong. That is point number one.

**Farland:** May I interject?

**Portier:** Go ahead.

**Farland:** I think this relates to a point that Chris already made, which is the fact that the addition or the explicit description of variability is something that I think is valuable and is an added feature of the analyses that he has done, and analyses that incorporate pharmacokinetic modeling do have the ability to describe those variabilities explicitly.

**Portier:** What my analysis really does is bring to light the following questions: Should we be basing our safe exposure estimates upon the fifth percentile, or upon the best estimate, or upon what percentile of the population? That is really what it is bringing into focus, is how do we really think about this. I can give you the entire distribution, not just the fifth percentile, or some estimate of the entire distribution. How do you use that? We like to think in terms of a single number in doing risk estimates and because of the problems that you foresee and that as we go to more and more and more complicated models we are going to get more and more and more dispersion, it really brings to light that we should think about that. It is not something I can think about as a statistician. I mean, that is a risk manager's problem.

**Miller:** Right. I am not finding fault with it. What I am saying is that we have to convey that sense of uncertainty in the proper perspective and that it is having to do as you relate to the population and risk management, not necessarily that the data upon which it is founded is that uncertain and so that they, in fact, use the tenth percentile or the fifth percentile, that they have an understanding of what they are using when they incorporate that in the risk management. So, I am not finding fault with, in fact, these analyses that do point out all of the uncertainties in the system. But we have to take care that it is not projected as just blurring it but actually helping us to understand where the real problems lie in the data base.

**Portier:** Just a final comment on that. I think that really what Fred is highlighting is what I would suggest in the process of really characterizing risks, and the fact that the importance here is to focus on risk characterization and not just on a single number or even a single classification for these complex situations where we know that the variability exists and the data are not there to really allow us to understand the full range of the implications of this single number that we have provided. So, again, just another hit on risk characterization and the way that we do business.

**(inaudible):** I would also like to highlight a distinction that might be muddled; that is, between variability and uncertainty. We have included in our analyses estimates that are due to uncertainty, say, in a population average. Those, theoretically, could be reduced but there still would be variability about those averages that can be, perhaps, better characterized but it would remain in whatever analyses were done.

**Dr Suresh Moolgavkar (Fred Hutchinson Cancer Center):** I would like to make some comments regarding my perspective on the two-stages of the two-mutation model that has been discussed this morning. That is the following: I do not think that at this stage of our knowledge of the biology of cancer any model can be said to be correct or the true model. That is clearly a truism. I think, what we can expect a model to do for us at this time is to provide a general framework within which the process of carcinogenesis can be viewed. Any good model should be consistent with all the available data and it should suggest experiments and laboratory measurements that we can actually, perform. And I think my perspective is that the two-mutation model is the most parsimonious model that is consistent with the data and also makes interesting predictions both in epidemiology and suggestions regarding lab experiments, for example, the IPI protocol that was referred to yesterday, and several other experiments that also are suggested. So, from the point of view of parsimony, I am glad that Chris Portier brought up this notion of what he calls the additive background model and the independent background model because we really do not have the biological data to decide that one or the other is correct. Again, I would say that in the interest of parsimony, perhaps we should be simply sticking with the so-called additive background model in which normal cellular transformation processes are affected somehow by chemicals, rather than the independent background model. It is possible to come up with an infinite variety of models, obviously, but we want to use the simplest one unless we have reasons to abandon it.

**Farland:** Yes, two comments. One, the person who has thought about these things much longer than I, once said, "All models are wrong, some are just more useful than others." And I think that probably characterizes what Suresh has said here. The second point is, in terms of some of the data that we are collecting these days, I think maybe it really does speak to trying to make a little broader context of discussion of this two-stage model. If we look at some of the oncogene data that has come out of the B6 mouse, and these are some early experiments and ones that will be extended by the

people at NIEHS, we may have the data very shortly to be able to separate effects of chemicals on oncogene activation relating to what apparently are two different stages of action in the progression to a liver tumor in the B6 mouse. So, I guess I would say that we are moving in that direction and maybe that is an example of how we might apply that broader context.

**Moolgavkar:** That would be very interesting to see. Also, in answer to a question or comment earlier by Harvey about when do we abandon one model and go to another, I think what I would be very interested in seeing, whether with any of these models, you can take data in species estimate the parameters, see how the model looks and so on, do the appropriate scaling, and predict response in another species. If you could do that in four or five years with reasonable accuracy, then I think that model deserves very serious consideration.

**Portier:** I agree with you about parsimony and attempting to explain the data but now we are going to do one additional thing and this is really the critical point I was trying to get at. You are going to do low-dose extrapolation with this model. I mean, that is the bottom line for EPA. They are going to have to estimate risk at small exposure levels.

## **CLOSING REMARKS**

**Colonel John J. Coughlin**

Two and one-half days ago Mel and I set out to establish a forum for free and open exchange of ideas and discussion on a very vexing and important problem facing not only the Department of Defense, but the country today. We set out to have a free and open exchange of ideas and discussion in a very difficult area and indeed succeeded and for that I thank all the attendees. It is only through progress of accommodating differing views of a very complexing issue that we will have any hope of meeting our challenge of taking data and providing meaningful information to decision makers and the public concerning the risks, risk assessment, and risk management issues and trade-offs that face the country today.

**ABSTRACTS FOR POSTERS**

(Arranged by order of presentation; asterisk indicates author presenting poster.)

## 1. EFFECTS OF CORN OIL GAVAGE ON HEPATIC TUMOR FORMATION IN THE B6C3F<sub>1</sub> MALE MOUSE

T.R. Weghorst,\* J.E. Klaunig, and C.M. Weghorst

Department of Pathology, Medical College of Ohio, Toledo, OH 43614

In most chronic carcinogenic bioassays, non-water soluble chemicals being tested have been administered via corn oil gavage. The use of corn oil as the vehicle for dissolving organic compounds has come under scrutiny due to its effects on chemical pharmacokinetics, metabolism, and possible tumor-promoting ability. The present study examined the effect of chronic corn oil gavage treatment on hepatic tumor formation in the B6C3F<sub>1</sub> male mouse. At 15 days of age, male B6C3F<sub>1</sub> mice were divided into four groups. Groups one and two received a single (ip) injection of diethylnitrosamine (DENA) (5 µg/g), while groups three and four received an equal injection of saline. At weaning (four weeks of age) mice in groups two and three were administered corn oil at a dose of 0.15 mL via gavage once a day, five days per week. Groups one and four were not administered corn oil. All mice were killed at 28 weeks of age and hepatic lesions were quantitated. Only mice exposed to DENA demonstrated hepatic tumors. No difference was noted in the size or number of focus transections per square centimeter between group one (DENA only) and group two (DENA + corn oil). No difference was seen in hepatic tumor response between the DENA and the DENA and corn oil-treated mice. Corn oil, therefore, under the conditions used in this study, did not act as a hepatic tumor promoter.

## **2. EFFECTS OF THE PEROXISOME PROLIFERATOR NAFENOPIN ON INTERCELLULAR COMMUNICATION IN CULTURED RAT HEPATOCYTES**

N.E. Schultz,<sup>1\*</sup> T.J.B. Gray,<sup>2</sup> and J.E. Klaunig<sup>1</sup>

<sup>1</sup>Department of Pathology, Medical College of Ohio, Toledo, OH 43614

<sup>2</sup>BP International, Surrey, England

Intercellular communication (IC) through gap junctions is thought to play a role in cell proliferation and differentiation. Alterations in intercellular communication may disrupt these cellular processes. Most compounds that induce peroxisome proliferation in rodent liver also have been shown to produce hepatocarcinogenesis in these same animals. These peroxisome proliferators appear to be functioning through promotion mechanisms. Inhibition of IC by tumor promoters may result in the isolation of preneoplastic cells that may proliferate and progress into neoplasia. In the present study, we have examined the effects of the peroxisome proliferator nafenopin on IC in rat hepatocytes. Isolated individual hepatocytes from male Fischer 344 rats were plated onto 60-mm culture dishes in Leibovitz L-15 media containing 5% fetal bovine serum, with or without hydrocortisone  $10^{-4}$  M. Dishes were re-fed and treated with either 50  $\mu$ m nafenopin or DMSO every 24 h for 5 days. IC was evaluated by microinjection of fluorescent dye (Lucifer Yellow CH) (dye-coupling) every 24 h (4 h after each treatment). Inhibition of IC occurred in the cells that had been treated chronically with nafenopin, after 48 h. This inhibitory effect on IC was increased after 72 h and 96 h. Cell cultures with and without hydrocortisone demonstrated similar results. Peroxisome proliferation was determined by measuring the palmitoyl CoA activity in the cultured hepatocytes at each of the sampling times. It appeared that the induction of peroxisome proliferation could be correlated with the inhibition of IC in the nafenopin-treated hepatocytes.

### 3. ORAL UPTAKE OF TRICHLOROETHYLENE (TCE) - VEHICLE EFFECTS

J.W. Fisher,<sup>1\*</sup> T.A. Whittaker,<sup>1</sup> C.D. Hinga,<sup>1</sup> and M.L. Gargas<sup>2</sup>

<sup>1</sup>AAMRL/THA, Wright-Patterson Air Force Base, OH 45433-6573

<sup>2</sup>AAMRL/THB, Wright-Patterson Air Force Base, OH 45433-6573

Male Fischer 344 (F-344) rats were gavaged with solutions of trichloroethylene (TCE) in water, mineral oil, and corn oil. A new non-invasive technique, previously described by Gargas et al. (1988) for estimating metabolic constants, was used for assessing the rate of gastrointestinal (GI) absorption of TCE. Oral uptake rate constants were estimated from experimentally determined exhaled breath levels using physiologically based pharmacokinetic modeling.

Absorption of TCE into systemic circulation from water (n = 8; dose = 1.0-6.5 mg/kg) in the GI tract was adequately described as a one compartment first-order process. The oral uptake rate constant ranged from 5 to 10/h and 100% of the dose was assumed to enter systemic circulation. Mineral oil and corn oil absorption kinetics were more complex. Two first-order rate constants were used to describe the rate of uptake of TCE from the oils in the GI tract. One rate constant described the rate of uptake of TCE from the GI tract into systemic circulation and the other, the rate of transfer of TCE from the GI tract into a "deep compartment," where TCE was unavailable for uptake into systemic circulation. The first-order uptake rate constant for mineral oil (n = 8; dose-5,20, and 50 mg/kg) ranged from 1 to 3/h, and for corn oil (n = 8; dose-5,20, and 50 mg/kg), ranged from 0.1 to 1.0/h. The model predicted that 50 to 75% of the TCE in the mineral oil was absorbed into systemic circulation, and only 1 to 25% of TCE in corn oil was absorbed into systemic circulation.

This technique appears to be a promising method for examining oral uptake of selected volatile chemicals. The effect of vehicle on GI absorption is substantial and appears to be an important consideration in pharmacodynamic studies.



#### 4. THE EFFECTS OF 1,1-DIMETHYLHYDRAZINE ON CELL MEMBRANE POTENTIAL AND INTRACELLULAR CALCIUM MOBILIZATION IN MURINE LYMPHOID CELLS

D.E. Frazier, Jr.,\* M.J. Tarr, and R.G. Olsen

Ohio State University, Department of Veterinary Pathobiology, 1925 Coffey Road, Columbus, OH 43210

A variety of chemicals and cell stimulants have been shown to influence free intracellular calcium ( $Ca^{++}$ ) levels and membrane potential. Altered membrane potential can affect levels of intracellular  $Ca^{++}$  and second messenger function in transduction of signals from cell surface receptors to intracellular targets. Altered lymphocyte activation or proliferation by 1,1-dimethylhydrazine (UDMH) could explain previously reported immunomodulatory activity as measured by mixed lymphocyte reaction and Jerne Plaque response. We examined the role of UDMH in perturbation of membrane potential and free intracellular  $Ca^{++}$  levels alone and with mitogen-stimulated murine lymphocytes. Preliminary results show that UDMH increases the level of free calcium in murine splenocytes. The level of free intracellular  $Ca^{++}$  and membrane potential was measured by uptake and excitation of several fluorescent cellular dyes via fluorescence-activated cell sorting and ultraviolet spectrofluorometry. We hope to further delineate the immunomodulatory effects of UDMH through these studies.

This work was supported in part by Grant No. 86-0129 from the Air Force Office of Scientific Research.

## 5. ACTIVITIES OF SELECTED CYCLIC HYDROCARBONS OF KNOWN CARCINOGENICITY IN THE V79 METABOLIC COOPERATION ASSAY

E. Elmore,<sup>1\*</sup> H.A. Milman,<sup>2</sup> B.P. Wilkinson,<sup>1</sup> G.P. Wyatt<sup>1</sup>

<sup>1</sup>NSI Environmental Sciences, P.O. Box 12313, Research Triangle Park, NC 27709

<sup>2</sup>U.S. EPA, 401 M Street, SW, Washington, DC 20460

Structurally similar cyclic hydrocarbons were evaluated in the V79 metabolic cooperation assay, and their responses were correlated to their known carcinogenicity. The carcinogens evaluated were 2,4-diaminotoluene, 2,5-diaminotoluene (suspect carcinogen), 2,4-dinitrotoluene, *o*-phenylenediamine, 4-chloro-*o*-phenylenediamine, 4-chloro-*m*-phenylenediamine, 2-nitro-*p*-phenylenediamine, 2,6-dichloro-*p*-phenylenediamine, 4,4'-methylenedianiline, 2-chlorobiphenyl (suspect carcinogen), and 2-phenoxyethanol (carcinogenicity unknown). The noncarcinogens evaluated were aniline (human), *m*-phenylenediamine, *p*-phenylenediamine, 2-chloro-*p*-phenylenediamine sulfate, and 4-nitro-*o*-phenylenediamine. The V79 metabolic cooperation assay is based on the recovery of 6TG resistant mutants from mixed cultures of wild type and mutant cells. Inhibition of cell-cell communication results in the enhanced recovery of mutant cells. For a compound to be considered positive, it must significantly enhance the recovery of mutant cells ( $p = 0.005$ , Dunnett's test), at least for two concentrations in two separate experiments or at three consecutive concentrations in one experiment. The sensitivity of the V79 metabolic cooperation assay to detect known rodent carcinogens was 82%. (The suspect carcinogens were included in this calculation.) The specificity of the assay was 75% and the accuracy, or the ability to identify both carcinogens and noncarcinogens, was 80%. The responses of the structurally related cyclic hydrocarbons in the V79 metabolic cooperation assay show a high correlation with their reported *in vivo* carcinogenicity.

## **6. STATISTICAL DESIGN CONSIDERATIONS FOR STAGewise, ADAPTIVE DOSE ALLOCATION IN DOSE RESPONSE STUDIES**

P.I. Feder,\* D.W. Hobson, C.T. Olson, and R.L. Joiner

Battelle Columbus Division, 505 King Avenue, Columbus, OH 43201

A principal design objective of many dose-response studies is to estimate extreme percentiles of a dose-response distribution (e.g., the ED<sub>95</sub> dose for a particular drug therapy) as precisely as feasible using the smallest number of experimental subjects possible. This design requirement necessitates that allocation of subjects to drug doses be carried out in a stagewise fashion to maximize the information obtained from each subsequent experimental observation in light of what has previously been determined concerning the shape of the dose-response distribution.

This presentation describes and illustrates specialized algorithms and associated computer programs to evaluate, on a stagewise basis, the anticipated relative sensitivities of alternative experimental plans in the case of dichotomous responses. Following each stage of experimentation, the current estimates of the dose-response distribution parameters, as well as the uncertainties in these estimates, are updated and are used to assign subjects to experimental dose levels for the next stage of testing. Competing dose allocations are compared with respect to anticipated improvement in estimation precision; that allocation that results in the smallest average variability of estimation, weighted over all plausible combinations of parameter values, is selected for the next stage. The entire process is iterated.

The adoption of such a stagewise dose-allocation strategy is illustrated by example. It is shown how the adaptive approach was able to accommodate to unforeseen occurrences midway during the experiment and result in midcourse modifications of dose allocations.

This work was supported by the U.S. Army Medical Research and Development Command under Contract DAMD17-83-C-3129.

## 7. EXPOSURE TO MULTIPLE ORGANOPHOSPHATES: ROLE OF A NOVEL CHOLINESTERASE "ALLOSTERIC" SITE IN TOXICITY MODIFICATION

A.K. Singh,\* M. Ashraf, and U. Mishra

Department of Veterinary Diagnostic Investigation, College of Veterinary Medicine, University of Minnesota, St. Paul, MN 55108

The objective of this investigation was to study the significance of a novel "allosteric" binding site, peripheral to the active site of cholinesterase (ChE) and acetylcholinesterase (AChE), in the modification of the toxicity of multiple organophosphate (OP) exposure. The enzyme samples were obtained from rat and fish brain, and from cockroach central ganglion. Crude synaptosomes were prepared by differential centrifugation from the fish and rat samples. The synaptosomal samples were incubated with the following various OPs: acephate, methamidophos, or paraoxon alone; acephate + methamidophos or paraoxon, simultaneously; and methamidophos or paraoxon after acephate. Timecourse of inhibition, bimolecular rate constant ( $k_i$ ), phosphorylation rate constant ( $k_p$ ), affinity constant for OPs ( $K_a$ ), and affinity constants for the "active" and "allosteric" sites ( $K_i$  and  $K_{ii}$ ) were determined.

We observed that (1) rat brain AChE contained an "allosteric" binding site that exhibited selective affinity for acephate, (2) the acephate-AChE binding altered the structure of the active site such that the phosphorylation capacity of other toxic OPs were significantly reduced, and (3) acephate exhibited low phosphorylation capacity for the rat AChE. Cockroach AChE did not contain the "allosteric" site, and acephate selectively bound to the enzyme's active site with a high phosphorylation rate. Although the fish brain AChE samples are presently being analyzed, the preliminary results have indicated that fish AChE may be similar to the cockroach AChE.

## 8. THE NATURE OF THE PROTECTIVE INTERACTION BETWEEN THE TERATOGEN HYDROXYUREA AND THE ANTIOXIDANT PROPYL GALLATE

J.M. DeSesso<sup>1\*</sup> and G.C. Goeringer<sup>2</sup>

<sup>1</sup>Toxic and Hazardous Materials Assessment and Control, The MITRE Corporation, McLean, VA 22102-3481

<sup>2</sup>Department of Anatomy and Cell Biology, Georgetown University School of Medicine, Washington, DC 20037

Hydroxyurea (HU) is a swiftly acting cytotoxic teratogen and an inhibitor of DNA synthesis. Within 2 h of maternal treatment, HU causes necrosis in proliferating tissues of rabbit embryos on gestational Day 12. Co-administration of the antioxidant propyl gallate (PG) delays the onset of necrosis until 6 h and ameliorates the teratogenic effects seen at term. Hydroxyurea also causes a rapid, profound decrease in uterine blood flow in pregnant rabbits. In order to establish that the site of HU-PG interaction is within the embryo, HU, HU-PG, or vehicle were administered by intrauterine injections directly into embryonic sites. When embryos were examined microscopically at 4 h, necrosis was observed only in the HU embryos. To resolve whether the amelioration of HU-induced embryotoxicity was due to decreased HU levels within HU-PG embryos, embryonic HU concentrations were measured at 15 min-- 8 h after maternal injection with HU or HU-PG. The HU levels of both groups coincided at all times examined. To determine whether PG alters the inhibition of DNA synthesis by HU, the incorporation of <sup>3</sup>H-thymidine into embryonic DNA was assayed at 2 h after maternal injection of HU, HU-PG, or vehicle. Both HU and HU-PG treatments produced a tenfold decrease in <sup>3</sup>H-thymidine incorporation relative to control. To establish whether the antioxidant properties of PG may cause the delay in the cytotoxicity, HU was administered with the antioxidants ethoxyquin (ETX) or nordihydroguaiaretic acid (NDGA) and embryos were analyzed microscopically at 4 h. Cytotoxicity was absent in both HU-ETX and HU-NDGA embryos. These data suggest that the amelioration of HU-induced embryotoxicity as reflected in the delayed onset of necrosis is due to an interaction between HU and PG within the embryo, that the interaction does not affect DNA synthesis, and that it may be due to the antioxidant properties of PG.

This work was supported by MITRE-Sponsored Research Project 9587C.

## 9. CORRELATION BETWEEN *IN VIVO* LIVER CARCINOGENICITY AND *IN VITRO* INHIBITION OF HEPATOCYTE INTERCELLULAR COMMUNICATION BY NONGENOTOXIC CARCINOGENS

R.J. Ruch,\* C.M. Weghorst, and J.E. Klaunig

Department of Pathology, Medical College of Ohio, Toledo, OH 43614

Intercellular communication (IC) through gap junctions may serve to regulate cellular growth and differentiation. The inhibition of IC by carcinogens may upset normal growth and differentiative processes and permit the proliferation of preneoplastic cells. This proliferation may enhance tumor formation. Several *in vitro* assays have been developed to determine if carcinogens inhibit IC. However, these tests have utilized embryonic, mesenchymal, and/or immortalized cells. In this study, we evaluated the effects of several nongenotoxic carcinogens on primary cultured adult, rodent hepatocyte IC with the hypothesis that these cells might be better predictors of *in vivo* liver carcinogenicity than other types of cells. Hepatocyte IC was detected (1) autoradiographically as the passage of [ $^3\text{H}$ ]uridine label between adjacent hepatocytes, or (2) as the passage of fluorescent Lucifer Yellow CH dye from microinjected, dye-loaded hepatocytes to neighboring hepatocytes. Carcinogens were tested at concentrations that were noncytotoxic; that is, that did not induce lactate dehydrogenase release from the cells into the culture medium. Phenobarbital (20-500  $\mu\text{g}/\text{mL}$ ); sodium barbital (200-1,000  $\mu\text{g}/\text{mL}$ ); DDT (1-30  $\mu\text{g}/\text{mL}$ ); lindane (1-20  $\mu\text{g}/\text{mL}$ ); dieldrin (1-10  $\mu\text{g}/\text{mL}$ ); trichloroethylene (5-50  $\mu\text{M}$ ) and its principal metabolite trichloroacetate (0.1-1 mM); and Aroclor 1254 (0.1-5  $\mu\text{g}/\text{mL}$ ) inhibited mouse hepatocyte IC. All of these compounds are mouse liver carcinogens. Amobarbital (23-230  $\mu\text{g}/\text{mL}$ ), barbituric acid (128-640  $\mu\text{g}/\text{mL}$ ), and saccharin (0.1-5 mM), which are not hepatocarcinogenic, did not inhibit mouse hepatocyte IC. There was a correlation between the ability of phenobarbital, DDT, and dieldrin to inhibit mouse hepatocyte IC, and the *in vivo* mouse strain specificity of these agents to induce liver tumor formation. In the rat, phenobarbital, sodium barbital, and DDT are hepatocarcinogenic. These compounds inhibited rat hepatocyte IC. Amobarbital, barbituric acid, dieldrin, and trichloroethylene are not rat liver carcinogens and did not affect rat hepatocyte IC. These data indicate that the inhibition of primary cultured hepatocyte IC by nongenotoxic carcinogens correlates with *in vivo* hepatocarcinogenicity. This suggests that the inhibition of hepatocyte IC should be further examined as an *in vitro* assay for liver carcinogens.

## 10. EFFECT OF PHENOBARBITAL ON DENA-INITIATED LIVER TUMORS IN MALE AND FEMALE B6C3F<sub>1</sub> MICE

C.M. Weghorst\* and J.E. Klaunig

Department of Pathology, Medical College of Ohio, Toledo, OH 43614

Previous studies have shown that the male B6C3F<sub>1</sub> mouse initiated with diethylnitrosamine (DENA) at 30 days of age followed by chronic phenobarbital (PB) administration displays an enhancement of hepatic tumor formation. Conversely, when male B6C3F<sub>1</sub> mice are initiated with DENA at 15 days of age, followed by chronic PB administration, an inhibition of liver tumorigenesis is seen. The present study was undertaken to evaluate the influence of gender on the inhibiting ability of PB in the 15-day-old, DENA-initiated, B6C3F<sub>1</sub> mouse. Male and female B6C3F<sub>1</sub> mice received a single (i.p.) injection of either DENA (5 µg/g) or saline at 15 days of age. At weaning (four weeks of age), mice were given either PB (500 ppm) in the drinking water or deionized drinking water. Mice were killed at 28 weeks of age and hepatic lesions quantitated. Male mice treated with DENA and PB exhibited a significant decrease in the number of hepatic adenomas compared to male mice treated with DENA alone. In contrast, female mice treated with DENA and PB demonstrated a significant increase in the number and incidence of hepatic adenomas compared to females receiving DENA only. In a separate experiment, individual preneoplastic foci from male and female B6C3F<sub>1</sub> mice initiated at 15 days of age were evaluated for their responsiveness to the mitogenic stimuli of PB. At 28 weeks of age, male and female mice containing foci were exposed to either PB drinking water or deionized drinking water for seven days. In non-PB treated males and females, preneoplastic hepatocytes demonstrated (by autoradiography) higher rates of DNA synthesis, compared to normal hepatocytes with no differences noted between genders. Male mice exposed to PB for seven days exhibited increased levels of DNA synthesis in normal cells but not in preneoplastic cells. Female mice treated with PB demonstrated significant increases in DNA synthesis in both preneoplastic and normal hepatocytes. These findings suggest that the differential response of male and female B6C3F<sub>1</sub> mice initiated at 15 days of age with DENA to PB promotion may be due to PB's ability (or lack thereof) to stimulate DNA synthesis in preneoplastic foci.

**11. COMPARATIVE HEPATOCYTE PROLIFERATION RESPONSE IN THE MOUSE AND RAT FOLLOWING ACUTE TREATMENT WITH TRICHLOROETHYLENE AND PHENOBARBITAL**

K.L. Fry,\* C.M. Weghorst, and J.E. Klaunig

Department of Pathology, Medical College of Ohio, Toledo, OH 43614

Trichloroethylene (TCE) has been shown to be a hepatocarcinogen in B6C3F<sub>1</sub> mice, but is refractory in Fischer 344 rats. The reason for this difference in hepatocarcinogenicity has been postulated to be related to the greater ability of the mouse liver to metabolize TCE, compared to the rat. In the present study we have investigated the relative proliferation effects in mouse and rat liver following acute exposure to TCE. Phenobarbital (PB) was also used as a positive control. Mice and rats were gavaged daily with TCE (1000 mg/kg) in corn oil. PB (500 ppm) treatment was via drinking water. Untreated and corn oil-treated controls were also performed. Immediately prior to treatment, osmotic mini-pumps containing tritiated thymidine were subcutaneously implanted. Animals were killed at 3, 7, and 14 days post-treatment; necropsied; and livers were processed for autoradiography. Hyperplastic and hypertrophic effects of the compounds were examined. In the mouse, statistically significant increases in DNA synthesis were induced with PB (24.4%) and TCE (15.7%), compared to corn oil (3.6%) and untreated (2.1%) controls after seven days. In the rat, significant increases in the DNA synthetic rate were noted only with PB (23.3%), compared to corn oil (3.0%) and untreated (3.1%) controls after seven days. TCE may produce its hepatocarcinogenic effect through tumor-promotion mechanisms. Therefore, the stimulation of DNA synthesis by this compound in the present study confirms its ability to function as a hepatic tumor promoter. Tumor promoters may serve to selectively induce the proliferation of previously initiated preneoplastic cells, thus allowing them to expand in number and possibly progress to neoplastic stages.



## 12. FAILURE OF THE "SOLT-FARBER PROTOCOL" TO INDUCE PRENEOPLASTIC OR NEOPLASTIC CHANGES IN THE B6C3F<sub>1</sub> MOUSE

S.G. Lilly,\* C.M. Weghorst, and J.E. Klaunig

Department of Pathology, Medical College of Ohio, Toledo, OH 43614

Resistance of initiated hepatocytes to hepatotoxins has been demonstrated in rat liver and has led to the "Solt-Farber resistant hepatocyte model" of carcinogenesis. The model states that initiated hepatocytes are resistant to the cytotoxic and mitoinhibitory effects of subsequent carcinogen administration and, therefore, have a proliferative advantage over the non-initiated hepatocyte. However, this resistant hepatocyte model has not been demonstrated for other species. Previous studies in our laboratory (*Cancer Letter* 26:295-301) have shown that neoplastic hepatocytes from male B6C3F<sub>1</sub> mice showed varied resistance to cytotoxicity by hepatotoxins compared to normal cells. Therefore, using the Solt-Farber protocol, we sought to validate the resistant hepatocyte hypothesis as a mechanism of hepatocarcinogenesis in the mouse. Male B6C3F<sub>1</sub> mice were subjected to the Solt-Farber protocol (DENA + 2-AAF + partial hepatectomy). Mice were sacrificed immediately and at 4, 8, and 16 weeks after completion of the Solt-Farber protocol. Livers were removed at necropsy and evaluated histologically for preneoplastic and neoplastic changes. Using the Solt-Farber protocol, no hepatic lesions were induced. Although the resistant hepatocyte model may be a mechanism for the development of hepatocarcinogenesis in the rat, the present study failed to confirm a similar mechanism in the mouse.

**13. DISSIMILAR PATTERNS OF HEPATIC TUMOR PROMOTION BY PHENOBARBITAL IN NEONATALLY INITIATED B6C3F<sub>1</sub>, C3H, AND C57/BL MALE MICE**

J.E. Klaunig\* and C.M. Weghorst

Department of Pathology, Medical College of Ohio, Toledo, OH 43614

Phenobarbital (PB) has been shown to be a potent hepatic tumor promoter when chronically administered to previously initiated rats and mice. Conversely, B6C3F<sub>1</sub> male mice initiated at 15 days of age with diethylnitrosamine (DENA) followed by long-term PB exposure demonstrate an inhibition of hepatocellular tumor formation. This study evaluated the effects of chronic PB administration on the two parental strains of the B6C3F<sub>1</sub> hybrid (as well as the hybrid itself) subsequently initiated with DENA at 15 days of age. Fifteen-day-old B6C3F<sub>1</sub>, C3H, and C57/BL male mice were divided into four groups of 10 per strain. Mice in groups one and two received a single injection (ip) of DENA (5 µg/g), while animals in groups three and four received an injection of saline. At weaning (four weeks of age), animals in groups two and three were given PB (500 ppm) in their drinking water for 24 weeks, while mice in groups one and four continued to receive deionized drinking water. All mice were killed at 28 weeks of age and necropsied. Hepatic lesions were classified and quantitated. Mice receiving only PB (group three) or no treatment (group four) did not display hepatic tumors. B6C3F<sub>1</sub> mice exposed to DENA and PB displayed a significant decrease in hepatic tumor formation compared to DENA-only treated B6C3F<sub>1</sub> mice, which confirms previous findings. C3H mice receiving DENA and PB demonstrated a significant increase in the number of hepatic adenomas compared to C3H mice treated with DENA alone. PB had no significant effect on liver tumor number in C57/BL mice treated with DENA compared to DENA-only treated C57/BL mice.

#### 14. BERYLLIUM OXIDE GENOTOXICITY IN CULTURED RESPIRATORY EPITHELIAL CELLS

V.E. Steele,<sup>1\*</sup> B.P. Wilkerson,<sup>1</sup> J.T. Arnold,<sup>1</sup> and R.S. Kutzman<sup>2</sup>

<sup>1</sup> NSI Environmental Sciences, Research Triangle Park, NC 27709

<sup>2</sup> NSI Environmental Sciences, Dayton, OH 45431

To determine the cytotoxicity, oncogenic potential, and genotoxicity of beryllium oxide particles in the respiratory tract, primary cultures of rat tracheal epithelial cells were exposed in culture to beryllium oxides formed at different temperatures. Beryllium oxide particles formed at low temperatures, high temperatures, and a sample of rocket motor exhaust material were tested. Cytotoxicity was measured by comparing the colony-forming efficiency of exposed and nonexposed primary cell cultures. All beryllium oxides were cytotoxic above 10-30  $\mu\text{g}/\text{mL}$ . At 100  $\mu\text{g}/\text{mL}$  the low-fired beryllium oxide and the rocket exhaust samples reduced to colony-forming efficiency by one-half compared to the high-fired samples. Oncogenic potential was measured by determining the frequency of morphological transformation of the primary cell cultures within 30 days of exposure. Two replicate assays were performed. Low-fired beryllium oxide transformed cultured rat tracheal epithelial cells at 0.3-3  $\mu\text{g}/\text{mL}$  in both assays. The high-fired and rocket motor exhaust samples gave mixed results (positive in one assay and negative in one assay). Genotoxic potential was measured by assessing the relative frequency of single-stranded DNA breaks between groups of primary cell cultures exposed to various beryllium oxides. Single-stranded breaks were measured using the alkaline elution technique. Two replicate tests were performed and the results were similar to the transformation results above. The results indicate that the low-fired beryllium oxide is positive, while the high-fired beryllium oxide and rocket motor exhaust have a weak potential for carcinogenicity and genotoxicity in respiratory tract epithelial cells.

## 15. NEOPLASTIC TRANSFORMATION IN PLANARIA

F.L. Hall, M. Morita, and J.B. Best\*

Department of Physiology, Anatomy, and Environmental Health, Colorado State University, Fort Collins, CO 80523

Although several investigators have reported that exposure to mammalian carcinogens induces abnormal tumor-like growths and teratogenic remodeling in planarians, there is no general agreement that these, or comparable responses in any other invertebrates, model mammalian carcinogenesis. To investigate this question, subjects of the species *Dugesia dorotocephala* were exposed to culture water containing an initiator and a promoter, either alone or in combination. Cadmium, a potent carcinogen, was used as an initiator in the protocol. Treatment with sublethal concentrations of cadmium sulfate produced a benign, but persistent, tumor in a small percentage of the planarians. The addition of 12-O-tetradecanoylphorbol-13-acetate (TPA), a phorbol ester and well-known promoter, to the cadmium-containing solutions resulted in the induction of a progressive, potentially lethal, transplantable tumor in a large proportion of the treated flatworms. Light and electron microscopy revealed this particular tumor to be comprised of a single cell type: newly differentiated reticular cells. Further examination of the infiltrating tissue formations elucidated the profile of differentiation, from a mitotically active assembly of neoblasts through the transitional stages in the associated reticuloma. These results suggest that (1) the freshwater planarian displays the major phenomenology of mammalian cocarcinogenesis, (2) the planarian reticuloma models several important features of a neoplastic stem cell disease, and (3) planarians may provide an inexpensive and relatively fast model system for investigating cocarcinogenic interactions.

## 16. CURRENT APPLICATION AND STUDIES ON HEALTH EFFECTS OF CARBON FIBERS – MILITARY POINT OF VIEW

D.R. Mattie<sup>1\*</sup> and M.J. Parnell<sup>2</sup>

<sup>1</sup> AAMRL/THD, Wright-Patterson Air Force Base, OH 45433-6573

<sup>2</sup> National Center for Toxicological Research, HFT-240, Jefferson, AR 72079

Carbon fiber composites are finding widespread use in military aircraft and space systems. Concern was raised over the possibility that respirable carbon fibers, released during thermal decomposition of the composites, could trigger pulmonary changes similar to those caused by asbestos. To determine if respirable carbon fibers pose a risk, two studies were conducted with carbon fibers artificially reduced in diameter by heating in a furnace at 575°C. Male Fischer 344 rats were injected intraperitoneally (i.p.) or instilled intratracheally (i.t.) with a suspension of reduced diameter fibers in distilled water. The suspension contained approximately 70% fibers with diameters less than 5 µm, 22% of which were less than 1 µm in diameter. Appropriate controls were included in both studies. Rats injected i.p. were sacrificed at 200 days and at two years. Two of six rats sacrificed at 200 days post-exposure had multiple fibers adhered to the capsule of the liver and occasionally fibers along the splenic capsule. No evidence of inflammatory cell infiltration was associated with the adhered fibers. Rats injected i.t. were sacrificed at 100 days, 200 days, one year, and two years. Carbon fibers were found in the lung at only 200 days after instillation of fibers. Scanning electron microscopy revealed minor ulceration of epithelial cells of the bronchi at all sacrifice times. There was no evidence of inflammation or hemorrhage. The incidence of tumors seen in control rats was equal to the incidence of tumors in rats exposed i.p. or i.t. to reduced diameter carbon fibers. Tumors were considered to be age-related. There was no indication of pulmonary carcinogenesis after essentially a life-time holding period.

**17. DEVELOPMENT OF A FISH PHYSIOLOGICALLY BASED TOXICOKINETIC MODEL FOR USE IN ENVIRONMENTAL RISK ASSESSMENT**

J.W. Nichols,<sup>1</sup> J.M. McKim,<sup>1\*</sup> M.E. Andersen,<sup>2</sup> M.L. Gargas,<sup>2</sup> and R.J. Erickson<sup>1</sup>

<sup>1</sup>U.S. EPA, Environmental Research Laboratory, Duluth, MN 55804

<sup>2</sup>AAMRL/TH, Wright-Patterson Air Force Base, OH 45433-6573

An interactive fish physiologically based-toxicokinetic (PB-TK) model was developed using *in vivo* and *in vitro* physiological and biochemical parameters for rainbow trout (*Salmo gairdneri*). Tissue groupings and blood flow relationships were adapted from an inhalation model for rats (Ramsey and Andersen, *Toxicol. Appl. Pharmacol.* 73: 159, 1984). Toxicant uptake and elimination at the gills was modeled as a counter-current exchange process regulated by gill ventilation, blood perfusion, and diffusion barriers at the gill epithelia. The model also may be adapted to include other routes of exposure and complex exposure regimens. *In vitro* chemical partitioning data for trout tissues was determined for a homologous series of chloroethanes (tri-, tetra-, penta-, and hexachloroethane) and model simulations generated that predict the uptake and disposition of these compounds. Experiments are planned to validate model outputs by exposing trout directly in fish respirometer-metabolism chambers. Comparison of these data with existing model outputs and data for rats will provide a physiological basis for evaluating toxicity extrapolations between lower and higher vertebrates.

## 18. PREDICTION OF TOXIC ENDPOINTS BY STRUCTURE-ACTIVITY RELATIONSHIPS

K. Enslein

President, Health Designs, Inc., Rochester, NY 14604

We have developed structure-activity relationship (SAR) equations for the prediction of a number of toxicological endpoints from the structure of (untested) chemicals. These equations are calculated using data bases of bioassay results. The independent parameters in the equations include substructural keys, molecular connectivity and kappa topological indices, and electronic charges. The endpoints for which SAR models exist include carcinogenicity, mutagenicity, teratogenicity, skin irritation, eye irritation, rat oral LD<sub>50</sub>, fathead minnow LC<sub>50</sub>, and *Daphnia magna* EC<sub>50</sub>. The accuracy of the equations ranges between 85% and 98%, depending upon the model. These equations have been implemented in the TOPKAT program, which runs on PC-AT class personal computers and is being adapted for the DEC VAX system.

The TOPKAT program will be demonstrated on a computer as part of this poster. Conference attendees are invited to submit compounds of interest for evaluation by the TOPKAT program during the poster session.

## 19. A NEW STRATEGY FOR ESTABLISHING COMBUSTION TOXICITY TEST STANDARDS

W.G. Switzer\* and H.L. Kaplan

Southwest Research Institute, San Antonio, TX 78284

Present combustion toxicity screening methods are based solely on the lethality of rodents, despite recognized limitations of the median lethal concentration (Sperling, 1976). These methods are inadequate for assessing the toxic hazards of combustion atmospheres for military environments and may actually lead to the selection of more toxic materials. Our laboratory is currently developing a new strategy to enable a valid assessment of the potential toxicity of smoke to man. In our two-tiered approach, materials are initially separated into two categories: low toxicity or potentially toxic. In the second tier, the major toxicants produced by the potentially toxic materials are identified by correlating toxicity data with analytical data for the common toxicants (i.e., CO, HCN, HF, acrolein, NO<sub>x</sub>, and SO<sub>2</sub>); depending upon the materials formulation. When the major toxicants have been identified, a valid assessment of the toxic hazard to man may be made from available human exposure data. If it is not possible to identify the major toxicants, then the toxicity data from rodents must be extrapolated to man. However, these data will include the nature and severity of clinical signs, the nature of the toxic effects, and the rapidity of these effects. Results of our studies demonstrating the validity and feasibility of this approach will be presented in detail.