

1

SSC-350

AD-A232 630

SHIP VIBRATION DESIGN GUIDE

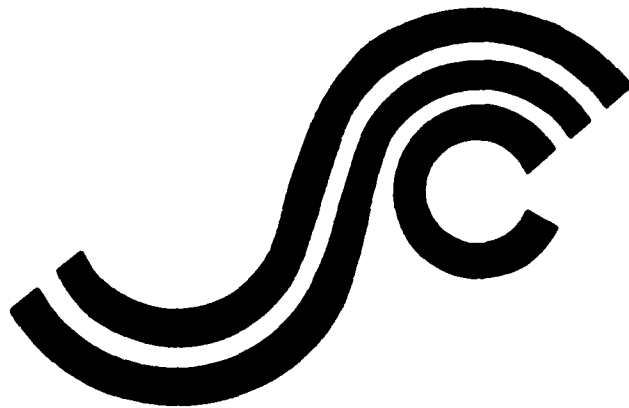

DTIC
ELECTE
MAR 5 1991
S B D

This document has been approved
for public release and sale; its
distribution is unlimited

SHIP STRUCTURE COMMITTEE

1990

SHIP STRUCTURE COMMITTEE

The SHIP STRUCTURE COMMITTEE is constituted to prosecute a research program to improve the hull structures of ships and other marine structures by an extension of knowledge pertaining to design, materials, and methods of construction.

RADM J. D. Sipes, USCG, (Chairman)
Chief, Office of Marine Safety, Security
and Environmental Protection
U. S. Coast Guard

Mr. H. T. Haller
Associate Administrator for Ship-
building and Ship Operations
Maritime Administration

Mr. Alexander Malakhoff
Director, Structural Integrity
Subgroup (SEA 55Y)
Naval Sea Systems Command

Mr. Thomas W. Allen
Engineering Officer (N7)
Military Sealift Command

Dr. Donald Liu
Senior Vice President
American Bureau of Shipping

CDR Michael K. Parmelee, USCG,
Secretary, Ship Structure Committee
U. S. Coast Guard

CONTRACTING OFFICER TECHNICAL REPRESENTATIVES

Mr. William J. Siekierka
SEA 55Y3
Naval Sea Systems Command

Mr. Greg D. Woods
SEA 55Y3
Naval Sea Systems Command

SHIP STRUCTURE SUBCOMMITTEE

The SHIP STRUCTURE SUBCOMMITTEE acts for the Ship Structure Committee on technical matters by providing technical coordination for determining the goals and objectives of the program and by evaluating and interpreting the results in terms of structural design, construction, and operation.

AMERICAN BUREAU OF SHIPPING

Mr. Stephen G. Arntson (Chairman)
Mr. John F. Conlon
Mr. William Hanzalek
Mr. Philip G. Rynn

NAVAL SEA SYSTEMS COMMAND

Mr. Robert A. Sielski
Mr. Charles L. Null
Mr. W. Thomas Packard
Mr. Allen H. Engle

MILITARY SEALIFT COMMAND

Mr. Albert J. Attermeyer
Mr. Michael W. Touma
Mr. Jeffery E. Beach

U. S. COAST GUARD

CAPT T. E. Thompson
CAPT Donald S. Jensen
CDR Mark E. Noll

MARITIME ADMINISTRATION

Mr. Frederick Seibold
Mr. Norman O. Hammer
Mr. Chao H. Lin
Dr. Walter M. Maclean

SHIP STRUCTURE SUBCOMMITTEE LIAISON MEMBERS

U. S. COAST GUARD ACADEMY

LT Bruce Mustain

NATIONAL ACADEMY OF SCIENCES - MARINE BOARD

Mr. Alexander B. Stavovy

U. S. MERCHANT MARINE ACADEMY

Dr. C. B. Kim

NATIONAL ACADEMY OF SCIENCES - COMMITTEE ON MARINE STRUCTURES

Mr. Stanley G. Stiansen

U. S. NAVAL ACADEMY

Dr. Ramswar Bhattacharyya

SOCIETY OF NAVAL ARCHITECTS AND MARINE ENGINEERS - HYDRODYNAMICS COMMITTEE

Dr. William Sandberg

STATE UNIVERSITY OF NEW YORK MARITIME COLLEGE

Dr. W. R. Porter

AMERICAN IRON AND STEEL INSTITUTE

WELDING RESEARCH COUNCIL

Dr. Martin Prager

Mr. Alexander D. Wilson

Member Agencies:

*United States Coast Guard
Naval Sea Systems Command
Maritime Administration
American Bureau of Shipping
Military Sealift Command*



**Ship
Structure
Committee**

An Interagency Advisory Committee
Dedicated to the Improvement of Marine Structures

Address Correspondence to:

Secretary, Ship Structure Committee
U.S. Coast Guard (G-MTH)
2100 Second Street S.W.
Washington, D.C. 20593-0001
PH: (202) 267-0003
FAX: (202) 267-0025

December 3, 1990

SSC-350
SR-1312

SHIP VIBRATION DESIGN GUIDE

Vibration control in ship structures is a major concern for those who design and operate vessels. Excessive vibrations can lead to fatigue failure in structural members and can adversely effect the efficiency of operating crews. Ignoring excitations caused by rotating machinery or propellers, for example, may lead to a vessel design that is unsuitable for service. This guide is intended to provide the reader with a method of integrating existing technology into the ship design cycle for the purpose of avoiding ship vibration problems.

J. D. SIPES
Rear Admiral, U.S. Coast Guard
Chairman, Ship Structure Committee

1. Report No. SSC-350	2. Government Accession No.	3. Recipient's Catalog No.	
4. Title and Subtitle Ship Vibration Design Guide		5. Report Date July 1989	
		6. Performing Organization Code	
7. Author(s) Edward F. Noonan		8. Performing Organization Report No. SR-1312	
9. Performing Organization Name and Address Edward F. Noonan 739 North Holly Drive Annapolis, MD 21401		10. Work Unit No. (TRAIS)	
		11. Contract or Grant No.	
12. Sponsoring Agency Name and Address Ship Structure Committee U.S. Coast Guard Headquarters (G-MTH) 2100 Second Street Washington, DC 20593-0001		13. Type of Report and Period Covered Final Report	
		14. Sponsoring Agency Code G-M	
15. Supplementary Notes The American Bureau of Shipping acted as the contracting office for the Ship Structure Committee			
16. Abstract It is the purpose of this design guide to integrate existing technology into the ship development program in a manner consistent with commercial ship design philosophies. The approach is based on experience and relies on emperical factors, where necessary. Weaknesses in the procedures are identified and recommendations for further development are indicated. This guide addresses the major components over which we have the ability to excercise control in the design phase, and which will generally minimize most local vibration probiems. These components include the hull girder, major structural elements, main propulsion systems including propeller selection, stern design and underwater appendages. Excitation forces, including those generated by propulsion systems and the operational environment that a ship's propeller and hull girder experience, are addressed in this guide. Transient excitation resulting from heavy seas and collision impact are not addressed in this document. A procedure to determine the natural frequencies of major shipboard elements at the preliminary design stage is presented to predict anticipated problems and facilitate selection of propulsion system components, stern configuration and hull structure.			
17. Key Words Shipboard Vibration Hull Structure Propulsion Machinery		18. Distribution Statement Available to the public from: National Technical Information Service, Springfield, VA 22161 or Marine Technical Information Facility National Maritime Research Facility Kings Point, NY 10024-1699	
19. Security Classif. (of this report) UNCLASSIFIED	20. Security Classif. (of this page) UNCLASSIFIED	21. No. of Pages 330	22. Price

METRIC CONVERSION FACTORS

Symbol	When You Know	Multiply by	To Find	Symbol
LENGTH				
in	inches	2.54	centimeters	cm
ft	feet	30	centimeters	cm
yd	yards	0.9	meters	m
mi	miles	1.6	kilometers	km
AREA				
in ²	square inches	6.5	square centimeters	cm ²
ft ²	square feet	0.09	square meters	m ²
yd ²	square yards	0.8	square meters	m ²
mi ²	square miles	2.6	square kilometers	km ²
acres	acres	0.4	hectares	ha
MASS (weight)				
oz	ounces	28	grams	g
lb	pounds	0.45	kilograms	kg
	short tons (2000 lb)	0.9	tonnes	t
VOLUME				
teaspoon	teaspoons	5	milliliters	ml
tablespoon	tablespoons	15	milliliters	ml
fluid ounce	fluid ounces	30	milliliters	ml
cups	cups	0.24	liters	l
pints	pints	0.47	liters	l
quarts	quarts	0.96	liters	l
gallons	gallons	3.8	liters	l
cu ft	cubic feet	0.03	cubic meters	m ³
cu yd	cubic yards	0.76	cubic meters	m ³
TEMPERATURE (exact)				
°F	Fahrenheit temperature	5/9 (after subtracting 32)	Celsius temperature	°C

Symbol	When You Know	Multiply by	To Find	Symbol
LENGTH				
mm	millimeters	0.04	inches	in
cm	centimeters	0.4	inches	in
m	meters	3.3	feet	ft
km	kilometers	1.1	yards	yd
		0.6	miles	mi
AREA				
cm ²	square centimeters	0.16	square inches	in ²
m ²	square meters	1.7	square yards	yd ²
km ²	square kilometers	0.4	square miles	mi ²
ha	hectares (10,000 m ²)	2.6	acres	acres
MASS (weight)				
g	grams	0.035	ounces	oz
kg	kilograms	2.2	pounds	lb
t	tonnes (1000 kg)	1.1	short tons	short tons
VOLUME				
ml	milliliters	0.03	fluid ounces	fl oz
l	liters	2.1	quarts	qt
l	liters	1.06	gallons	gal
m ³	cubic meters	0.26	gallons	gal
m ³	cubic meters	36	cubic feet	ft ³
		1.3	cubic yards	yd ³
TEMPERATURE (exact)				
°C	Celsius temperature	9/5 (then add 32)	Fahrenheit temperature	°F

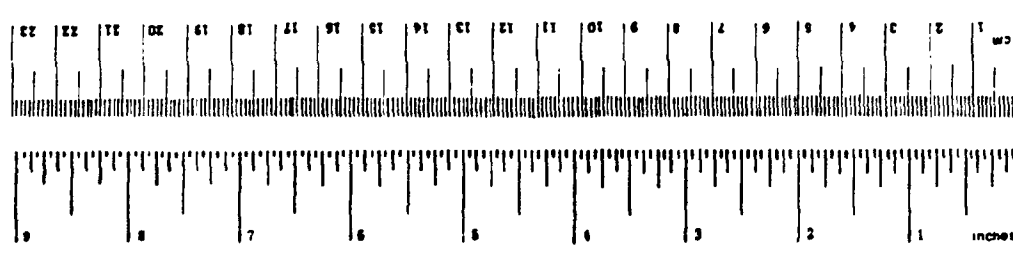

*In 3, 2, 4, 5, and 11, for other exact conversions and more detailed tables, see NBS Misc. Publ. 286, *Handbook of Metric and Metric-Imperial Conversion*, Page E7-25, SD Catalog No. C1310-108.

PREFACE

A ship is a complex structure propelled by an equally complex propulsion system, subjected to self generated dynamic forces of a periodic nature, as well as serious transient forces generated by random seas. Under the general title of Shipboard Vibration, we would normally include everything that vibrates, whether excited by periodic or transient forces, whether the response is noted in a major structural or mechanical component, or in local joiner work, or in a piping run. For this guide, however, we will address the major components over which we have the ability to exercise control in the design phase, and which will generally minimize most local vibration problems. These components will include the hull girder, major structural assemblies, main propulsion systems, including the propeller, stern configuration and underwater appendages. Structural reliability of the ship, responding to the transient excitation produced by heavy seas, is ordinarily established by the Classification Societies, as discussed in the recent paper on "Strength Assessment of Ocean Going Vessels" presented by Thayamballi and Chen in SNAME's 1987 Transactions and are not included in this design guide.

Because of the interdisciplinary nature of ship vibration problems and the complexity of the total mechanical system, the design of a ship, free from objectionable vibration, is still considered an art in which the designer applies his own approach to ensure satisfactory performance. Although much research has been carried out in recent years, it has generally been fragmentary in nature and not effectively reduced to a practical design guide, useful for the low budget, commercial ship design projects.

It is the purpose of this design guide to integrate existing technology into the ship development program, in a manner consistent with commercial ship design philosophies. The approach is based on experience and relies on empirical factors, where necessary. Weaknesses in the procedures are identified and recommendations for further development are indicated. A more detailed outline of the background and approach to this guide was presented by the author in the paper, "Shipboard Vibration Can Be Controlled" at SNAME's Chesapeake Marine Engineering Symposium in 1986.

Recently, a companion effort, "Practical Guide for Shipboard Vibration Control and Attenuation" (SSC-330), was developed to provide operators, shipyards, shipowners and others who must deal with ship vibration problems, but who have limited knowledge and experience in the field, with an understanding of the nature of the more common problems frequently encountered, how to assess and evaluate them, and what alternatives are available for their solution. Where applicable, sections of the original text were also included in this publication.

In the development of this guide, an effort has been made to present sufficient information to understand the basis for the observed vibration phenomenon. It is recommended that the reader make use of selected references given for a more in depth understanding. It is suggested that "Ship Hull Vibration" (Todd, E.F., Edward Arnold Ltd.), "Ship Vibration" (McGoldrick, R.T., DTMB Report 1451), and "Mechanical Vibrations" (Den Hartog, J.P., McGraw Hill) be referred to for a more complete understanding of shipboard vibration.



By _____	
Distribution/	
Availability Codes	
Dist	Avail and/or Special
A-1	

TABLE of CONTENTS

ACKNOWLEDGMENTS.....	i
PREFACE.....	iii
TABLE of CONTENTS.....	v
LIST of FIGURES and TABLES.....	xi

CHAPTER ONE

INTRODUCTION to SHIPBOARD VIBRATION

1.1 Purpose And Scope	1-1
1.2 Shipboard Vibration	1-2
1.3 Hull Girder Vibration	1-3
1.3.1 Hull Girder Excitation	1-3
1.3.1.1 Shaft Frequency Forces	1-4
1.3.1.2 Propeller Forces	1-5
1.3.2 Hull Girder Response	1-7
1.3.2.1 Modes of Vibration of the Hull Girder	1-8
1.3.2.2 Frequency of Vibration of the Hull Girder	1-8
1.3.2.3 Effects of Adverse Operating Conditions	1-1
1.4 Vibration of Major Substructures.....	1-13
1.5 Vibration of Local Structural Elements	1-14
1.6 Vibration of Shipboard Equipment	1-14
1.6.1 Passive Shipboard Equipment.....	1-15
1.6.2 Active Shipboard Equipment	1-15
1.7 Vibration of Main Propulsion Machinery.....	1-15
1.7.1 Dynamic Unbalance and Misalignment	1-16
1.7.2 Dynamic Shaft Stresses	1-17
1.7.3 Longitudinal Vibration	1-17
1.7.4 Torsional Vibration.....	1-18
1.7.5 Lateral Vibration.....	1-19
REFERENCES.....	1-20
APPENDIX 1-A, Useful Dynamics Formulas	

CHAPTER TWO

VIBRATION CRITERIA and SPECIFICATIONS

2.1 General Hull Vibration.....	2-2
2.2 Major Substructures, Local Structures And Shipboard Equipment.....	2-6
2.2.1 Human Reaction	2-6
2.2.2 Equipment Malfunction.....	2-6
2.2.2.1 Structural Adequacy of Support System.....	2-6
2.2.2.2 Vibration of Shipboard Equipment	2-7
2.2.3 Environmental Testing of Shipboard Equipment.....	2-8
2.2.3.1 Vibration Tests	2-8
2.2.3.2 Exploratory Vibration Test.....	2-8
2.2.3.3 Endurance Test	2-8
2.2.3.4 Variable Frequency Test	2-8

Ship Vibration Design Guide

2.2.3.5 Exception.....	2-8
2.2.3.6 Endurance Test for Mast-Mounted Equipment	2-9
2.2.4 Structural Fatigue Failure.....	2-9
2.2.4.1 Hull Girder Vibration (Springing)	2-9
2.2.4.2 Local Vibration	2-11
2.3 Machinery Vibration	2-11
2.3.1 Main Propulsion Machinery.....	2-11
2.3.1.1 Dynamic Unbalance and Misalignment.....	2-12
2.3.1.2 Dynamic Shaft Stresses.....	2-13
2.3.1.3 Torsional Vibration	2-14
2.3.1.4 Longitudinal Vibration.....	2-14
2.3.1.5 Lateral Vibration	2-15
2.3.2 General Machinery Vibration	2-15
2.3.2.1 Nonreciprocating Machines	2-15
2.3.2.2 Reciprocating Engines.....	2-22
2.4 Ship Vibration Specifications	2-22
SAMPLE SHIP SPECIFICATIONS: Vibration	2-24
A. General Requirements	2-24
B. Hull Girder Criteria	2-24
C. Criteria for Major Substructures	2-24
D. Criteria for Local Structural Elements.....	2-24
E. Criteria for Shipboard Equipment	2-25
F. Vibration of Main Propulsion Machinery	2-25
REFERENCES	2-29

CHAPTER THREE

EXCITATION of VIBRATORY FORCES

3.1 Guidelines for Minimization of Propeller-Induced Vibratory Forces	3-2
3.1.1 Approach	3-2
3.1.2 Selection of Afterbody Type.....	3-2
3.1.3 Development of Afterbody Shape	3-6
3.1.3.1 Design of Closed-Stern Afterbodies for Single Screw Ships.....	3-6
3.1.3.2 Design of Open-Stern Afterbodies.....	3-15
3.1.3.3 Selection of Propeller to Hull Clearances.....	3-15
3.1.4 Development of Shapes and Arrangement of Aft Apendages	3-23
3.1.5 Selection of Propeller Characteristics	3-25
3.2 Early Design Stage Estimates of Propeller-Induced Vibratory Forces and Moments	3-40
3.2.1 Approach	3-40
3.2.2 Example.....	3-45
3.3 Guidelines for Minimization of Propulsion System Induced Vibratory Forces and Moments	3-45
3.4 General Comments and Recommendations	3-46
REFERENCES	3-47
APPENDIX 3-A, Example of Early-Design-Stage Estimate of Propeller Induced Vibratory Forces and Moments	

CHAPTER FOUR
SHIP HULL VIBRATION

4.1 The Design Approach.....	4-1
4.1.1 Scope of Ship Vibration Analyses	4-2
4.1.2 Contractual Considerations.....	4-3
4.1.3 Stages of Ship Design	4-3
4.1.3.1 Concept Design	4-3
4.1.3.2 Preliminary Design	4-4
4.1.3.3 Contract Design	4-4
4.1.3.4 Detail Design	4-4
4.1.3.5 Construction.....	4-4
4.1.3.6 Tests and Trials	4-4
4.1.3.7 Ship Operation.....	4-5
4.2 Preliminary Hull Vibration Design Analysis	4-5
4.2.1 Hull Frequency Determination	4-6
4.2.1.1 Empirical Analysis	4-6
4.2.1.2 20-Station Beam Model.....	4-6
4.2.1.3 Finite Element Model.....	4-7
4.2.2 Empirical Calculation Procedures	4-17
4.2.2.1 Destroyer Calculations	4-17
4.2.2.2 LNG Calculations	4-26
4.2.2.3 Current Hull Designs.....	4-34
4.2.2.4 Examples of Other Ship Types	4-37
4.3 Preliminary Hull Response Analysis.....	4-39
4.3.1 Avoiding Hull Resonance	4-39
4.3.2 Forced Hull Response	4-42
4.3.2.1 Estimated Hull Forces	4-42
4.3.2.2 Hull Response.....	4-42
4.3.3 Resonant Hull Response.....	4-43
4.3.3.1 Hull Vibratory Forces.....	4-46
4.3.3.2 Hull Damping	4-46
4.3.3.3 Concept Design-Estimated Response.....	4-47
4.3.3.4 Preliminary Design-Calculated Hull Response.....	4-50
4.4 General Comments and Recommendations	4-51
4.4.1 General Comments	4-54
4.4.2 Recommendations.....	4-54
REFERENCES.....	4-55
APPENDIX 4-A, ABS Comments	

CHAPTER FIVE
PROPULSION SYSTEM VIBRATION

5.1 Dynamic Unbalance and Misalignment	5-2
5.1.1 Unbalanced Propeller Forces.....	5-2
5.1.2 Misalignment	5-4
5.1.3 Diesel Engine Unbalance	5-4
5.1.3.1 External Forces and Moments.....	5-5

Ship Vibration Design Guide

5.1.3.2 Internal Forces and Moments.....	5-9
5.1.3.3 Lateral Moments	5-10
5.2 Dynamic Shaft Stresses.....	5-12
5.2.1 Tailshaft Design	5-13
5.2.2 Thrust Eccentricity	5-17
5.2.3 Detail Design Considerations.....	5-21
5.3 Longitudinal Vibration of Propulsion Systems.	5-23
5.3.1 Longitudinal Vibration Analysis of the LNG Carrier	5-23
5.3.1.1 Longitudinal Shaft Vibrations.....	5-25
5.3.1.2 Comments.....	5-28
5.3.1.3 Frequency Analysis - Conventional Hull	5-31
5.3.1.4 Response Calculations.....	5-33
5.3.2 Longitudinal Critical Within the Operating Speed.....	5-34
5.3.2.1 Frequency Analysis.....	5-34
5.3.2.2 Response Analysis.....	5-42
5.3.2.3 Diesel Propulsion Drive Systems.....	5-44
5.3.3 General Comments.....	5-45
5.4 Torsional Vibration of Propulsion Systems.....	5-46
5.4.1 Torsional Vibration Analysis of the LNG Carrier Propulsion System	5-47
5.4.1.1 Frequency Analysis of Project Hull.....	5-48
5.4.1.2 Frequency Analysis of Conventional Hull	5-49
5.4.1.3 Response Calculations.....	5-50
5.4.2 Direct Diesel Drive Systems	5-52
5.5 Lateral Vibration of Propulsion Shafting.....	5-53
5.5.1 Lateral Vibration (Whirling) Frequency of the LNG Carrier.....	5-55
5.6 General Comment	5-56
REFERENCES	5-57
APPENDIX 5-A, Example of Preliminary Vibration Analysis of Propulsion System	
APPENDIX 5-B, Slow-Speed Diesel Data	

CHAPTER SIX

MEASUREMENT and ANALYSIS of SHIPBOARD VIBRATION

6.1 Background	6-1
6.1.1 SNAME Vibration Program.....	6-2
6.1.2 ISO Standards.....	6-2
6.1.2.1 The Use of Shipboard Vibration Standards.....	6-3
6.2 Instrumentation.....	6-6
6.2.1 Mechanical Instruments	6-6
6.2.1.1 Reeds	6-6
6.2.1.2 Askania.....	6-6
6.2.2 Transducers	6-6
6.2.2.1 Accelerometers	6-6
6.2.2.2 Velocity Gages	6-7
6.2.2.3 Displacement Gages.....	6-7
6.2.2.4 Strain Gages	6-8
6.2.3 Signal Conditioners.....	6-8

6.2.3.1	Differential Amplifiers	6-8
6.2.3.2	Charge Amplifiers	6-8
6.2.3.3	Strain Gage Amplifiers.....	6-9
6.2.3.4	Filters	6-9
6.2.4	Recorders	6-9
6.2.4.1	Meters	6-9
6.2.4.2	Oscilloscopes	6-10
6.2.4.3	Oscillographs	6-10
6.2.4.4	Tape Recorders.....	6-11
6.3	Quantities To Be Measured.....	6-11
6.3.1	Displacement, Velocity, or Acceleration	6-12
6.3.2	Frequency Range.....	6-12
6.3.3	Time History or Frequency Spectra	6-12
6.4	Analysis and Reporting Of Data	6-13
6.4.1	Manual Method	6-13
6.4.2	Envelope Method.....	6-16
6.4.3	Spectral Method.....	6-21
6.4.4	Histograms of Instantaneous Values	6-23
6.4.5	Histograms of Peak Values	6-24
6.4.6	Reporting Formats	6-24
6.5	Transducer Locations	6-25
6.5.1	Hull Stern.....	6-26
6.5.2	Thrust Bearing	6-26
6.5.3	Main Propulsion System, Longitudinal.....	6-26
6.5.4	Deckhouse.....	6-28
6.5.5	Hull Girder.....	6-28
6.5.6	Rotating Machinery	6-28
6.5.7	Resonant Equipment.....	6-29
6.5.8	Torsional Vibration.....	6-29
6.5.9	Main Propulsion System, Lateral	6-29
6.5.10	Local Structures.....	6-32
6.6	Test Conditions.....	6-33
6.7	Test Procedures.....	6-33
6.7.1	Calibration Procedures	6-33
6.7.1.1	Accelerometers	6-34
6.7.1.2	Velocity Gages	6-34
6.7.1.3	Proximity Probes	6-34
6.7.1.4	Strain Gages.....	6-34
6.7.2	Communications	6-35
6.7.3	Hull and Main Propulsion System Vibration.....	6-35
6.7.4	Auxiliary Machinery.....	6-36
6.8	General Comments and Recommendations	6-36
6.8.1	General Comments on Instrumentation.....	6-37
6.8.2	Recommendations.....	6-41
	REFERENCES.....	6-42
	APPENDIX 6-A, Vibration Generator Tests	

LIST of FIGURES and TABLES

Main Excitation Sources.....	1-4
Action of Free Forces And Moments of the Main Engine on Hull Girder	1-5
Description of Bearing Forces and Moments.....	1-7
Description of Hull Pressure Forces And Moments	1-8
Hull Girder Vertical of 2-5 Nodes (1st - 4th Mode).....	1-9
Hull Girder Horizontal Vibration of 2-5 Nodes (1st - 4th Mode).....	1-9
Hull Girder Torsional Vibration.....	1-10
Hull Girder Longitudinal Vibration.....	1-10
Plots of Hull Girder Vertical Vibration.....	1-12
Superstructure Longitudinal Vibration	1-14
Longitudinal Vibration of Shafting System	1-17
Torsional Vibration of Typical Shafting System	1-18
Whirling Vibration of Shafting.....	1-19
Position of Aft Bearing Support.....	1-19
Table 1-A-1 Natural Frequencies of Common Systems	1-A-1
Table 1-A-2 Stiffness of Common Structures.....	1-A-5
Table 1-A-3 Inertias of Common Cross Sections	1-A-7
Notation for Appendix 1-A.....	1-A-8
Guidelines for the Evaluation of Vertical and Horizontal Vibration in Merchant Ships	2-3
Guidelines for Ship Vibration - Vertical and Horizontal.....	2-4
Comparison Between ISO 6954 and Addendum 3 to ISO 2631	2-5
Table 2-1 Vibration Test Requirements for Shipboard Equipment and Machinery.....	2-9
Vibration Test Requirements for Various Categories of Shipboard Equipment (Proposed)....	2-10
Table 2-2 Types of Correction	2-12
Maximum Allowable Vibration, Type II (MIL-STD-167-1 (SHIPS), 1 May 1974)	2-16
Main Propulsion Steam Turbines and Reduction Gears - Turbine Bearing Housing and Gear Casing Vibration Limits	2-17
Main Propulsion Gas Turbines Bearing Housing Vibration Limits	2-18
Main Propulsion Units - Shaft Vibration Limits.....	2-19
Turbine Driven Auxiliaries - Bearing Housing Vibration Limits.....	2-20
Turbine Driven Auxiliaries - Shaft Vibration Limits.....	2-21
Vibratory Levels of Diesel Engines and Reciprocating Engines.....	2-23
Table 3-2 Balancing Procedure Criteria.....	2-25
Overall Hydrodynamic Design Sequence for Minimization of Propeller-Induced Vibratory Forces.....	3-3
Wake Fraction of Various Types of Ships Based on Results of Model Tests at DTRC [3-2] ..	3-4
Relationship for Cavitation Number Versus Wake Non-Uniformity Parameter with Data Points Based on Actual Ship Performance and on Model Test Wake Surveys for These Ships	3-5
Afterbody Configuration and Wake Characteristics of an Open-Stern Single-Screw Ship.....	3-7

Ship Vibration Design Guide

Afterbody Configuration and Wake Characteristics of a Conventional, Closed-Stern Single-Screw Ship.....	3-8
Afterbody Configuration and Wake Characteristics of a Modified-Hogner, Closed-Stern Single-Screw Ship.....	3-9
Selected Afterbody Configuration for an LNG Ship and Associated Wake Characteristics	3-10
Thrust-Deduction Fraction of Various Types of Ships Based on Results of Model Tests at DTRC [3-2].....	3-11
Criterion Plot for Gross Estimate of Wake Non-Uniformity Parameter Value Based on Block Coefficient [3-3].....	3-11
Suggested Criteria for Afterbody Design.....	3-12
Suggested Relationships Between Axial Wake Variation and Half Angle of Flow Line at 0.8R [3-5]	3-13
Suggested Non-Uniformity Criterion [3-6].....	3-14
Tip Clearance versus Propeller Loading for S.S. Navy Ship [NAVSEA]	3-16
Tip Clearance versus Propeller Diameter and Blade Loading as Recommended by Several Classification Societies for a Particular Ship Design	3-17
Table 3-1 Classification Society Guidance on Propeller Clearance.....	3-18
Table 3-2 Propeller Clearances Recommended by Classification Society Guidance for Example Ship (T-AO).....	3-19
Guidance for Selection of Clearance Ahead of Propeller Based on Data from Actual Operating Ship [3-9]	3-21
Guidance for Selection of Propeller Tip Clearance Based on Data from Actual Operating Ship [3-9]	3-22
Actual and Minimum Required Propeller Blade Clearance for an Example Ship.....	3-24
Variation of Blade Rate Peak-to-Peak Hull Pressure Over Propeller Tip versus Ship Speed for U.S. Navy Oiler, Based on Model Tests	3-25
Burrill Cavitation Diagram [3-9].....	3-27
Vibration Problem Areas Identified in a versus CT Diagram [3-15, 3-16]	3-28
Vibration Problem Areas Identified in a versus CT Diagram [3-15, 3-16]	3-29
Normalized Thrust (F_3) and Horizontal Bending Moment (M_1) Variations at Blade Frequency Shown as Mean Values and Standard Deviations. Four-, Five-, and Six-Bladed Propellers Fitted on Conventional Single-Screw Ships.....	3-30
Effect of Number of Propeller Blades on Vertical Excitation Force [3-18]	3-30
Modified Burrill Cavitation Diagram [3-19].....	3-31
Propeller Characteristics for Maximum Loading with Uniform Inflow (Case 1): Maximum $C_{Th} = 0.64$, 5 Blades, PAR = 0.8, Design $C_L = 0.200$ [3-19].....	3-33
Propeller Characteristics for Maximum Loading with Open Stern-Low Speed (Case 2): Maximum $C_{Th} = 0.50$, 5 Blades, PAR = 0.8, Design $C_L = 0.150$ [3-19].....	3-33
Propeller Characteristics for Maximum Loading with Open Stern-High Speed(Case 3A): Maximum $C_{Th} = 0.50$, and with Hogner Stern (Low Speed) (Case 3B): Maximum $C_{Th} = 0.40$, 5 Blades, PAR = 0.8, Design $C_L = 0.125$ [3-19].....	3-34
Propeller Characteristics for Maximum Loading w/ Hogner Stern-High Speed(Case 4A): Maximum $C_{Th} = 0.40$, and with Conventional Stern (Low Speed) (Case 4B): Maximum $C_{Th} = 0.32$, 5 Blades, PAR = 0.8, Design $C_L = 0.100$ [3-19]	3-34

Variation of Propeller Efficiency with Diameter and Delivered Power at 16 Knots, w = 0.40, t = 0.20, Submergence to 0.7R = 1.6 Diameter [3-19].....	3-36
Variation of Propeller Efficiency with Diameter and Delivered Power at 24 Knots, w = 0.30, t = 0.20, Submergence to 0.7R = 1.2 Diameter [3-19].....	3-36
Variation of Propeller Efficiency with Diameter and Delivered Power at 32 Knots, w = 0.20, t = 0.20, Submergence to 0.7R = 0.8 Diameter [3-19].....	3-37
Variation of Propeller Efficiency with Ship Speed and Power for a 30 foot Diameter Propeller [3-19]	3-37
Variation of Cavitation-Limited Delivered Power (DHP) with Ship Speed for Various Propeller Diameters [3-19].....	3-38
Variation of Cavitation-Limited Effective Power (EHP) with Ship Speed for Various Propeller Diameters [3-19].....	3-38
Effect of Blade Skew on Hull Pressure.....	3-39
Table 3-3 Characteristics of Generally Similar Twin-Screw Ships and Associated Vibratory Force Data.....	3-41
Table 3-4 Vibratory Force Data for Large, Single-Screw LNG Ship Design.....	3-42
Calculated Propeller Forces for Generally Similar Twin-Screw Ships	3-42
Table 3-5 Normalized Values of Unsteady Thrust and Unsteady Torque for a Number of Ships	3-43
Hull Lines for T-AO 187 Class Fleet Oiler	3-A-1
Original T-AO 187 Shafting Arrangement.....	3-A-3
T-AO 187 Effective Horsepower Curves	3-A-4
Table 3-A-1 Propeller Characteristics	3-A-5
Table 3-A-2 Characteristics of Comparative Twin-Screw Naval Ships.....	3-A-6
BHP versus RPM for SWD 9 TM 620	3-A-7
Calculated Propeller Forces for Comparative Twin-Screw Naval Ships	3-A-9
Avondale LNG Ship, Modeling Procedure	4-8
Avondale Hull Finite Model Aft of BHD 104, 3-D View.....	4-9
Avondale Hull Complete Ship Model, 3-D View.....	4-10
Isometric View of Finite Element Model.....	4-11
Table 4-1 Calculated Vertical Hull Frequencies	4-18
Vertical Mode Shapes.....	4-19
Shear Correction Factors [4-1]	4-20
Horizontal 2 - Node Hull Frequencies [4-1]	4-21
Table 4-2 Calculated Horizontal Hull Frequencies.....	4-23
Horizontal Mode Shapes.....	4-24
Torsional Mode Shapes	4-25
Table 4-3 Calculated Torsional Hull Frequencies.....	4-26
Table 4-4 Calculated Vertical Hull Frequencies (Hz)	4-27
France - Dunkerque LNG Ship Hull Frequencies.....	4-28
Avondale LNG Ship Hull Frequencies.....	4-29
Higher Frequency Ratios, Vertical Vibration [4-1].....	4-31
Higher Frequency Ratios, Horizontal Vibration [4-1]	4-32
Table 4-5 Calculated Horizontal Hull Frequencies,(Hz).....	4-33
Table 4-6 Estimated Vertical Hull Frequencies (Hz).....	4-36

Ship Vibration Design Guide

Table 4-7 Estimated Horizontal Hull Frequencies, Ship II, (Hz).....	4-37
Table 4-8 Examples of Hull Frequencies for Other Ship Types.....	4-38
Range of Vertical, Horizontal and Torsional Frequencies from Light to Full Load Compared with 4 - Bladed or 5 - Bladed Propeller Frequencies	4-40
External 1st and 2nd Order Moments for 4, 5 and 6 Cylinder Two-Stroke Engines	4-41
Table 4-9 Amplitude at the Stern, æ mils.....	4-43
Variations of Hull Impedances versus Ship Displacement.....	4-44
ISO Guidelines for Vertical and Horizontal Vibration in Merchant Ships	4-45
Table 4-10 Step Function Input Damping Factors	4-47
Hull Damping versus Frequency.....	4-48
France-Dunkerque Hull Response	4-52
Predicted Avondale Hull Response.....	4-53
Table 4-A-1 Estimation of 2-Node Mode Natural Frequency (Hz) for Tankers	4-A-2
Table 4-A-2 Estimation of Natural Frequency Ratio for Higher Mode of Tankers	4-A-2
Table 5-1 Unbalanced Moments in Two-Stroke Engines	5-5
External First and Second Order Moments for Four-, Five-, and Six-Cylinder, Two-Stroke Engines.....	5-6
External Moments (or Couples) of Engines.....	5-6
Balancing of First Order Moment.....	5-7
Additional Balancing of First Horizontal Moment.....	5-7
Action of External (Free) Forces and Moments on the Hull Girder	5-8
Mechanical Exciter Fitted to Compensate for Slow-Speed Diesel Engine Excitation of the Hull Girder.....	5-9
Effect of Lateral Moments on Engine Frame	5-10
Installation of Hydraulic Stays Between Engine and Ship Structure	5-11
Preliminary Shafting Arrangement for LNG Project Hull.....	5-16
Stern Configuration and Wake Components for LNG Carriers	5-18
Thrust Eccentricity for Alternate LNG Stern Configurations.....	5-19
Values of Thrust Eccentricities for Three Stern Forms.....	5-20
Polar Diagram of Thrust Eccentricity for Destroyer.....	5-21
Polar Diagram of Thrust Eccentricity for Center and Starboard Wing Propellers (Four Blades).....	5-22
Table 5-2 Results of Calculations of Propeller Forces Based on NSMB Data.....	5-24
First Mode Frequency versus Thrust Bearing Stiffness (K_3) and Foundation Stiffness (K_4) for Project Hull	5-27
Table 5-3 Frequency Estimate	5-30
Preliminary Shafting Arrangement for LNG Conventional Design	5-31
First Mode Frequency versus Thrust Bearing Stiffness (K_3) and Foundation Stiffness (K_4) for Conventional Hull	5-32
Estimated Response of Machinery System to Longitudinal Vibration	5-33
Shafting Arrangement.....	5-35
Lever Effect Representation of Example Problem Foundation Mass M_4	5-37
Stiffness of Thrust Bearing Housing and Support versus Full Power Thrust.....	5-38
Stiffness of Kingsbury Thrust Bearing Elements as Calculated by Kingsbury	5-38
Preliminary Method for Determining First-Mode Longitudinal Frequency.....	5-39

Foundation Stiffness versus Full Power Thrust	5-40
Mass-Elastic Representation of Example Problem	5-40
Equilibrant Damping Constant at Propeller as a Function of Propeller Developed Area.....	5-42
Calculated Blade Frequency-Alternating Thrust at Thrust Bearing for Six-Bladed Propeller and Comparison with MIL-STD-167A Criteria	5-43
Calculated Longitudinal Vibratory Response of Example Propulsion System with a Six-Bladed Propeller	5-44
Estimated Response of Machinery System to Torsional Vibration	5-52
Harmonic Analysis, Heavy Load - Calm Sea	5-54
Preliminary Shafting Arrangement.....	5-A-3
Table 5-A-1 Calculated Shaft Diameters in Inches	5-A-5
Mass-Elastic Model for Longitudinal Shaft Vibration.....	5-A-8
Table 5-A-2 Longitudinal Natural frequencies and Mode Shapes	5-A-9
Table 5-A-3 Shaft Stiffnesses.....	5-A-9
Assumed Dimensions of Shafts Used for Calculating Stiffness	5-A-9
Table 5-A-4 Calculation of Masses.....	5-A-10
Table 5-A-5 Characteristics of T-AO 187 Propeller.....	5-A-10
Axial Natural Frequency vs. Bull Gear Mass and Thrust Bearing/ Foundation Stiffness.....	5-A-12
Table 5-A-6 Calculated Response Amplitudes	5-A-13
Torsional Mass-Elastic System.....	5-A-15
Torsional Mode Shapes	5-A-16
Torsional Natural Frequencies versus Coupling Stiffnesses and Bull Gear and PTO Inertias for 80 RPM System.....	5-A-17
Torsional Natural Frequencies versus Coupling Stiffnesses and Bull Gear	
Various Types of Waveforms.....	6-15
Table 6-1 Calculated Attenuations Due to One Filter	6-17
Normalized Attenuation Characteristics of Krohn-Hite 3550 Filters	6-17
Table 6-2 Calculated Attenuations Due to Two Filters	6-18
Vertical Blade Frequency Displacement of a Ship's Stern.....	6-19
Vertical Blade Frequency Displacement of a Ship's Stern Recorded at Various Slow Speeds	6-20
Sample Peak Spectra for Various Locations.....	6-22
Typical Cumulative Distribution Plot with Cursor Set for 99 Percent Probability	6-23
Location of Transducers for Main Engine (Turbine) Vibration [6-5]	6-27
Location of Transducers for Vibration of Aft End of Line Shafting.....	6-30
Location for Transducers for Main Engine (Direct-Drive Diesel) Vibration [6-5].....	6-31
Location of Pressure Transducers [6-5]	6-32
Comparison of El Paso Savannah Data Analyzed with Different Methods	6-39
Table 6-3 Filter Induced Errors.....	6-40

INTRODUCTION TO SHIPBOARD VIBRATION

Vibration aboard ships can result in fatigue failure of structural members or major machinery components, adversely affect the performance of vital shipboard equipment, increase maintenance costs, and greatly increase discomfort or annoyance to passengers and crew. Generally, hull vibration will be identified as objectionable to the crew before it becomes damaging to the ship's structure. However, failure of major machinery components and vital equipment can occur without significant annoyance to those aboard the ship.

The design and construction of a ship free of excessive vibration continues to be a major concern. The principle reasons include the interdisciplinary nature of the problem, which requires the coordination of naval architects, hydrodynamicists, structural and mechanical engineers, and the lack of suitable vibration criteria, specifications and design procedures. During the design of new naval or commercial vessels with long lead time and large design budgets, it is possible to implement a development program that includes model studies and extensive computer programs, which will optimize the chances of obtaining the desired results. Unfortunately, in the development of the average, low budget commercial ship or naval auxiliary, the lack of suitable specifications and design procedures may result in a ship with unsatisfactory vibration characteristics.

1.1 Purpose And Scope

It is the purpose of this design guide to provide a basic approach to the integration of design considerations in the development of a ship, which will provide reasonable assurance of satisfactory vibration characteristics. Although many parts of this guide would be useful on most ships, it is primarily applicable to turbine and diesel-driven ships of 100 meters or greater. This guide should be useful during both preliminary and detailed design stages. Preliminary vibration design studies are aimed at the confirmation of the many design considerations associated with the selection of:

- stern configuration
- main propulsion machinery
- propeller and shafting system
- location and configuration of major structural assemblies, such as deckhouse, superstructure and large deck panels

Preliminary vibration studies are required before design details are fixed. Additionally, detailed vibration studies are required during detail design and construction to confirm that the predicted performance will satisfy the specifications given the leeway to perform minor alterations to optimize performance. Depending on the specifications, experience and other considerations, the detailed vibration design studies may be limited.

1.2 Shipboard Vibration

The best way of understanding the nature of shipboard vibration is to experience it firsthand. The complexity of the phenomena ranges from piping vibration to total vibration of the hull, the failure of a reduction gear, a propeller shaft, or the global movement of a deckhouse. Having experienced serious shipboard vibration, you will readily recognize the necessity of investigating the likelihood of its occurrence prior to the approval of a design for construction.

Although the complete ship can be represented by a total mass-elastic system, in which all parts mutually interact, a detailed analysis of the total ship generally cannot be evaluated in the early stages of design. In the preliminary design phase, many elements have not been firmly established because they are relatively unimportant and don't justify the cost and time required for a more detailed analysis. A reasonable alternative was presented in "An Assessment of Current Shipboard Vibration Technology," [1-1], in which, for convenience, the total ship is divided into five parts:

- Hull Girder
- Major Structural Substructures
- Local Structural Elements
- Shipboard Equipment
- Main Propulsion Machinery Systems

Considering the ship in this light is particularly helpful in the diagnosis, evaluation and development of corrective action in the resolution of shipboard vibration problems.

The first three elements are structural and in descending order of size, are primarily excited by propeller or diesel propulsion engine forces transmitted through the structures, and responsive directly to the applied forces as transmitted by the intervening structure.

Shipboard equipment is classified as active when it generates vibratory forces or passive if it does not. As an example, a generator set is active and an electrical transformer is passive. The response of shipboard equipment may be related to its own exciting forces or to those transmitted through the ship's structure.

The main propulsion machinery system may be excited by the ship's propeller, by dynamic or hydrodynamic unbalance, or, in the case of diesel engine applications, by harmonics of the engine. Excessive vibration of the machinery system can prove to be damaging to the hull structure, equipment, or to the machinery system itself.

An understanding of the excitation and response of these individual elements and their interrelationship will assist in the diagnosis of most vibration problems encountered. Each of the five elements are treated in greater depth in the following sections.

1.3 Hull Girder Vibration

The ship's hull girder includes the shell plating, main deck, and all internal members, which collectively provide the necessary strength to satisfactorily perform the design functions of the ship in the expected sea environment.

The hull girder responds as a free-free beam (both ends free) when subjected to dynamic loads. Although the surrounding water and loading of the hull influences its response, the hull girder will always respond as a free-free beam. Vibration of the hull girder, excited by alternating propeller forces, represents the most frequent source of troublesome vibration encountered aboard ship. The vibration characteristics of the ship are primarily established by the propeller and stern configuration. After the ship is built, modifications to correct excessive vibration resulting from improper selection of propeller and/or stern configuration are generally most extensive and impractical. In addition, vibration of the hull girder will excite major substructures, local structural elements, and shipboard equipment. Main propulsion machinery and auxiliary machinery can also contribute to general hull vibration and the vibration of local structural components.

A ship's hull girder responds in vertical flexure when subjected to wave impact. In oceangoing ships subjected to random seas, the dynamic response at the fundamental natural frequency of the hull is normally at low stress levels and is referred to as transient in nature and is not treated in this publication. In the case of ore carriers on the Great Lakes, however, periodic vibration of the hull girder at its fundamental natural frequency has been found to be a potentially dangerous structural problem that is referred to as Springing.

1.3.1 Hull Girder Excitation

Dynamic forces entering the hull through the propulsion shaft bearings or directly through propeller blade pressure forces impinging against the hull account for the majority of hull girder vibration. In the case of slow-speed diesel engine drive systems, engine unbalance or firing forces may also be important. Less important sources are auxiliary machinery and hydrodynamically excited appendage vibration. When attempting to determine the source of vibration, it is necessary to determine the frequency of excitation and it is convenient to relate it to the shaft rotational frequency by determining the number of oscillations per shaft revolution (order). The total signature may include first order, blade-frequency, harmonics of blade frequency, as well as constant frequency components. Primary excitation sources are shown in Figure 1-1, from [1-2].

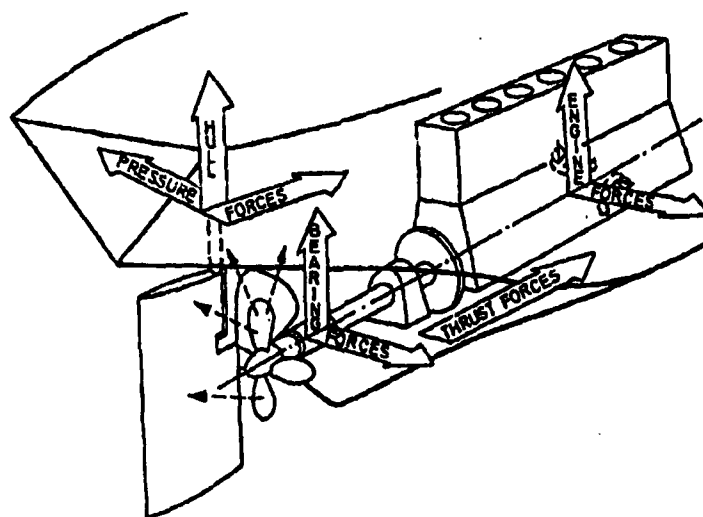

Figure 1-1
Main Excitation Sources

1.3.1.1 Shaft Frequency Forces

Mechanical forces that are associated with shaft rotational speed (1st order) may result from one or more of the following causes:

- A. Shaft unbalance
- B. Propeller unbalance
- C. Propeller pitch error
- D. Engine unbalance (for slow-speed diesel driven ships)
- E. Bent shafting
- F. Journal eccentricity
- G. Coupling or flange misalignment

The most likely causes of shaft frequency forces are attributed to A, B, C, and D above. The other possible causes are not as likely to occur if reasonable specifications, workmanship, and inspection procedures are exercised during the design and construction of the ship.

Shaft frequency forces occur within a low frequency range. They are, however, of considerable concern since they may be of large magnitude and may excite one of the lower hull modes at or near full power, thus producing a significant resonant effect.

The principal engine unbalance encountered with slow-speed diesel driven ships are the primary and secondary free engine forces and moments. Of particular concern is the magnitude of the

forces and moments, the location of the engine, and the possible correlation of these inputs with the lower vertical and athwartship natural frequencies of the hull girder. Primary forces and moments occur at shaft frequency and the secondary forces and moments occur at twice shaft frequency. The magnitude of these forces and moments should be furnished by the engine builder. The effect of free forces and moments of the main engine on the hull order is shown in Figure 1-2, from [1-3].

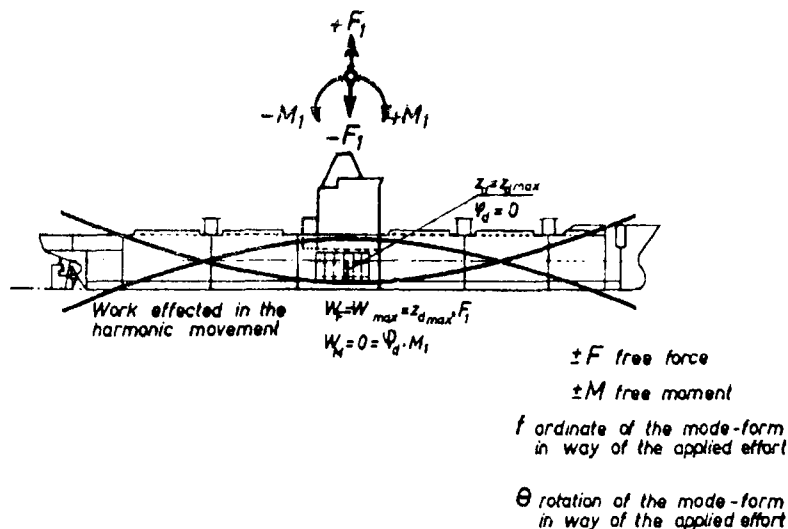

Figure 1-2
Action of Free Forces And Moments of the Main Engine on Hull Girder

1.3.1.2 Propeller Forces

In addition to the basic design purpose of generating steady thrust for the ship's propulsion, the marine propeller also generates undesired fluctuating dynamic forces and moments due to its operation in a nonuniform wake caused by the passage of the blades close to the hull and appendages. These fluctuating forces and moments are usually referred to as propeller forces and are at fundamental blade frequency and higher harmonics. The higher harmonics are normally of secondary importance. These propeller forces are in turn categorized as either bearing or hull pressure forces.

A more detailed description of the alternating forces generated by a ship's propeller may be obtained in "Principles of Naval Architecture," published by SNAME and the many papers presented on the subject in recent years. However, for purposes of this guide, it would be helpful to provide some physical insight on how a propeller generates the unsteady forces and moments.

Propeller theory relates to operation "in open water," in which the propeller is advancing into undisturbed water. However, when it is operating behind the hull it is working in water that has been disturbed by the passage of the hull and the water around the stern has acquired a forward motion in the same direction as the ship. This forward moving water is called the

Ship Vibration Design Guide

wake and it varies in the plane of the propeller disc, giving rise to variations in loading on each blade as the propeller rotates.

Since the propeller produces both torque and thrust, both components vary with each blade as it passes through the uneven wake, which gives rise to alternating torque and thrust at propeller blade frequency and harmonics of blade frequency. As a further effect of the uneven loading of the propeller, the center of thrust is eccentric to the physical center of the propeller, thus creating bending moments in the shaft and vertical and transverse forces in the bearing [1-4]. These forces are also at blade frequency and harmonics of blade frequency while the principal bending stress in the shaft occurs at the shaft frequency with smaller components at $n - 1$ and $n + 1$, where n = the number of propeller blades.

Similarly, alternating pressure forces are generated by the operation of the propeller blades adjacent to the hull surfaces in the axial and transverse directions. The resulting forces and moments generated on the hull surface reacts with the propeller blades to produce bearing forces. To minimize these forces, maximum clearances are required in the axial (forward) directions and radially at the propeller tip. The propeller generated hull pressure forces are greatly increased if cavitation exists [1- 5]. The collapse of air pockets produce implosions, which are characterized by the hammering frequently noted in the stern compartment and the presence of vibration at higher harmonics of blade frequency.

1.3.1.2.1 Bearing Forces. Unsteady bearing forces originate from the nonuniformity of the wake in the plane of the propeller disc. The strength of the various harmonics of the wake affects the magnitude of the bearing forces and influence the choice of the number of propeller blades. The relative strength of the various orders of wake harmonics is indicative of the relative strength of the blade-frequency forces. The wake, in turn, is influenced by the design of the hull form. An optimum design of the hull form would reduce the nonuniformity of the wake, thereby reducing the magnitude of the bearing forces. Bearing forces excite the ship through the propulsion shafting/bearing system and are fully described by six components illustrated in Figure 1-3. As shown in Figure 1-3, with the origin of axes at the center of the propeller, these components are the thrust and torque in and about the longitudinal or fore and aft axis; the horizontal bearing force and the vertical bending moment in and about the horizontal or athwartship axis; and the vertical bearing force and horizontal bending moment in and about the vertical axis.

Fluctuating vertical and horizontal bearing forces result from differences in torsional forces on the blades of the propeller, while the vertical and horizontal bending moments are due to the propeller thrust vector centered at a point that is eccentric to the center of the propeller.

1.3.1.2.2 Hull Pressure Forces. Hull pressure forces originate from the pressure variation caused by the passage of propeller blade tips close to the hull and appendages. The hull pressure forces are affected by propeller-hull clearance, by blade loading, and by changes in the local pressure field around the blade. The occurrence of blade cavitation will drastically increase the pressure forces. In some cases, a 20 to 40 times increase of hull pressure forces due to cavitation has been observed in experimental measurement, as compared to non-cavitating condition [1-5]. The pressure forces excite the ship through the hull bottom

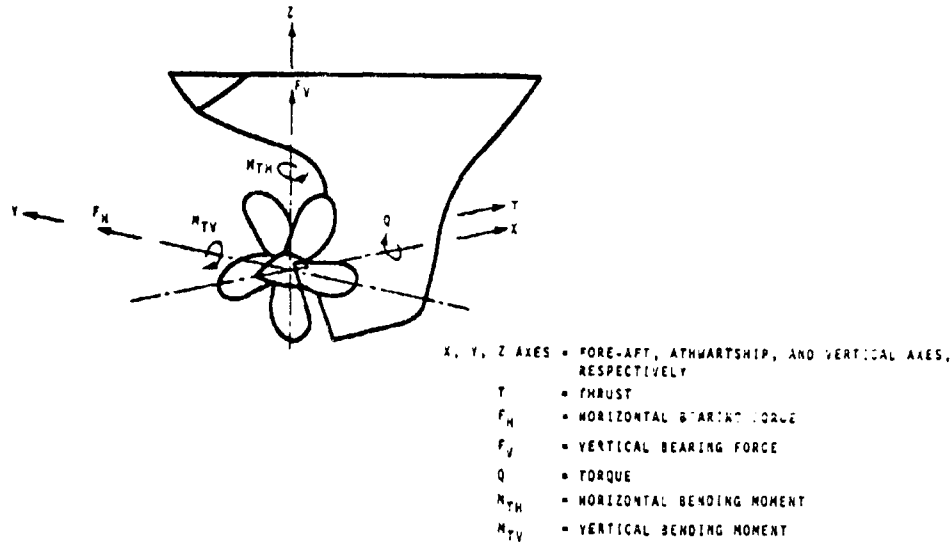

Figure 1-3
Description of Bearing Forces and Moments

surface in way of and adjacent to the propeller. The pressure forces are fully described by six components: the longitudinal force and moment in and about the fore-aft axis, the horizontal force and vertical moment in and about the athwartship axis, and the vertical force and horizontal moment in and about the vertical axis illustrated in Figure 1-4.

1.3.1.2.3 Effect of Propeller Forces. The alternating blade frequency thrust of the bearing forces provides the principal excitation to the propulsion system in the longitudinal mode, while the blade frequency torque constitutes the principal excitation to the propulsion system in the torsional mode. The blade frequency vertical bearing force, when vectorily combined with the blade frequency vertical pressure force, provides the total vertical force, which excites the hull in the vertical direction. Similarly, the horizontal bearing forces, when combined with the blade frequency horizontal pressure forces, provides the major contribution for exciting the hull in the horizontal direction. The vertical and horizontal forces and their distance from the neutral axis of the hull combine to excite the hull torsionally. Longitudinal hull pressure forces and alternating thrust entering the hull through the thrust bearing will combine to excite the hull in the longitudinal direction.

1.3.2 Hull Girder Response

The response of the hull girder may be resonant or nonresonant (forced). It is likely to be resonant through the first five or six modes of vibration when driven by the shaft or if propeller frequencies are present. Above the fifth or sixth mode, the hull girder vibrates approximately in proportion to the generated forces (forced vibration). Principal exciting frequencies are shaft frequency, propeller blade frequency, and harmonics of propeller blade frequency. Hydrodynamic forces may also stimulate the resonant frequency of hulls, rudders, or struts excited by hydrodynamic flow over the appendage.

Ship Vibration Design Guide

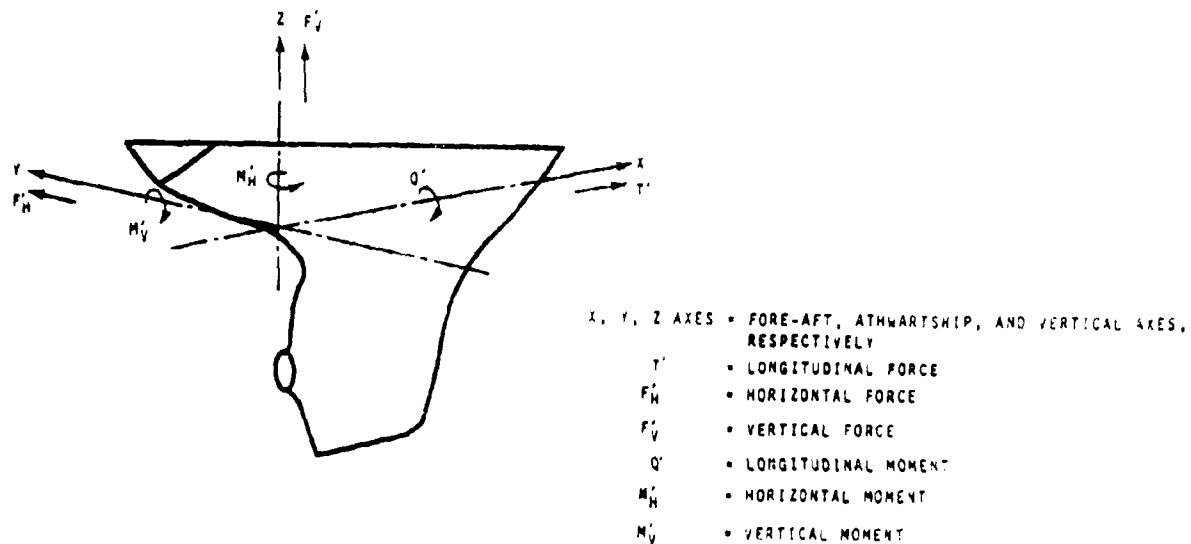

Figure 1-4
Description of Hull Pressure Forces and Moments

1.3.2.1 Modes of Vibration of the Hull Girder

The hull girder will normally vibrate in the following modes:

- Vertical Flexure (Figure 1-5)
- Horizontal Flexure (Figure 1-6)
- Torsional (Twist) (Figure 1-7)
- Longitudinal (Compression) (Figure 1-8)

Coupling may exist between vertical and longitudinal and between horizontal and torsional modes. The most significant vibration is normally associated with vertical and horizontal flexure.

1.3.2.2 Frequency of Vibration of the Hull Girder

Vertical flexural hull vibration is the most important type of resonant hull vibration encountered in service. As previously noted, this may be excited by dynamic or hydrodynamic unbalance of the propeller, dynamic unbalance or eccentricity of shafting or other large rotating masses such as bull gears, and by primary or secondary unbalanced moments of direct drive diesel engines. Transient forces, introduced by sea waves, may also excite hull natural frequencies.

In twin screw ships significant excitation of horizontal modes may occur due to phasing of propeller unbalance forces.

Some ships, particularly container ships with large deck openings may be sensitive to torsional response excited by horizontal forces.

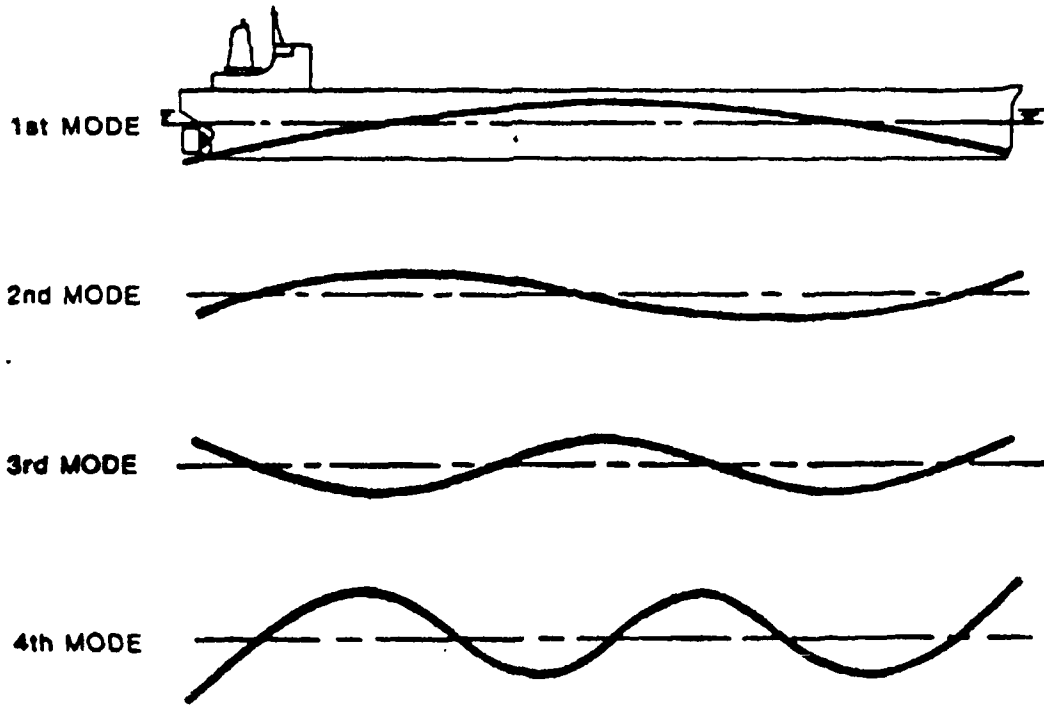

Figure 1-5

Hull Girder Vertical of 2-5 Nodes (1st - 4th Mode)

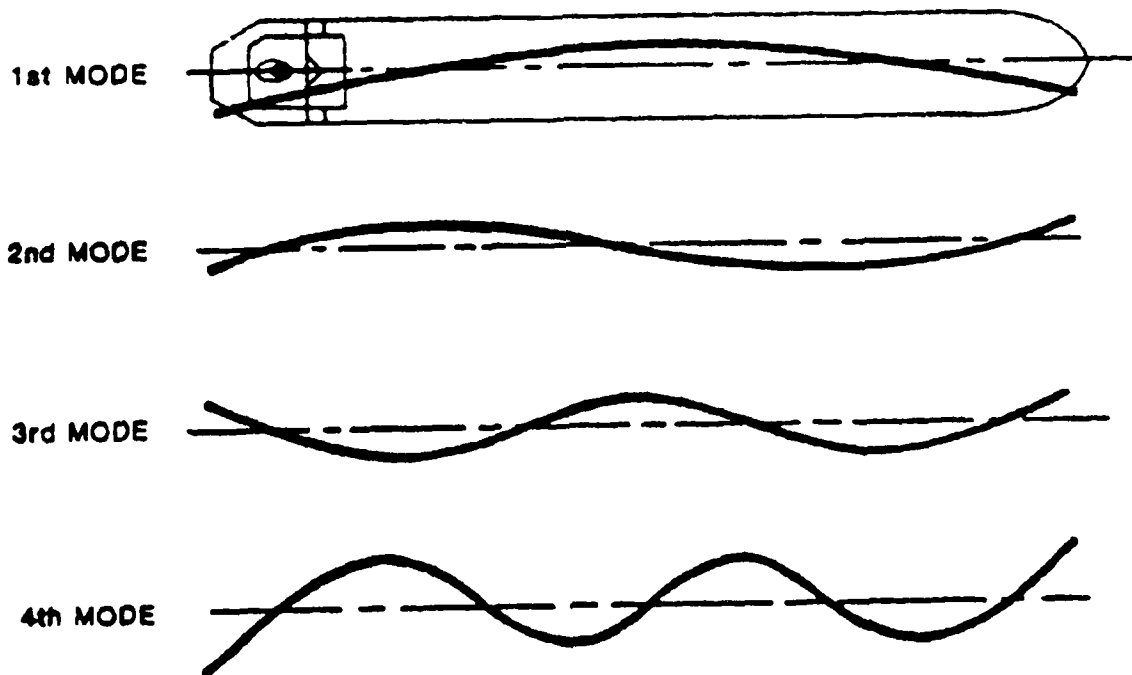

Figure 1-6

Hull Girder Horizontal Vibration of 2-5 Nodes (1st - 4th Mode)

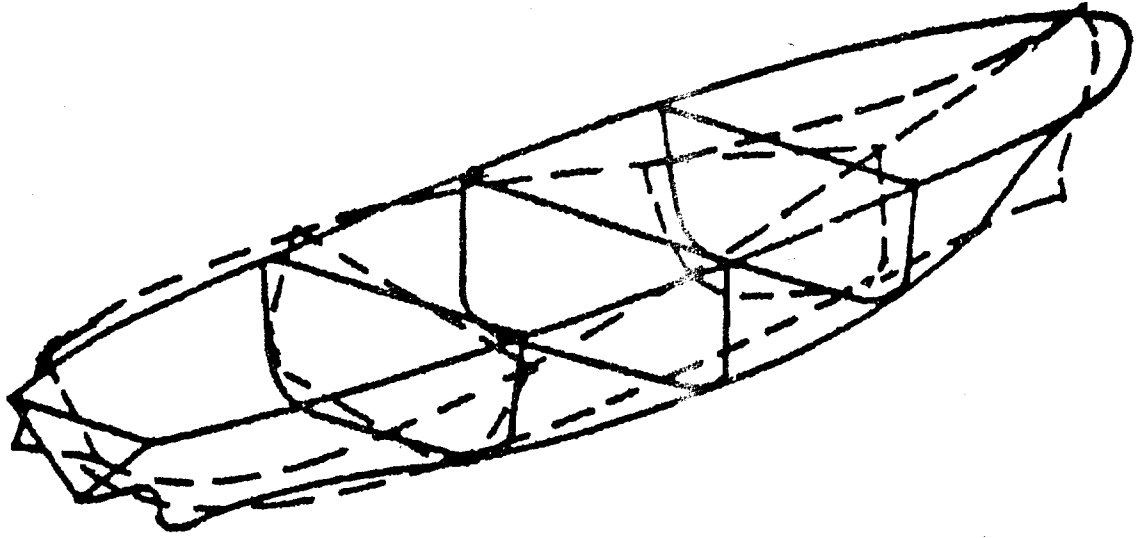

Figure 1-7
Hull Girder Torsional Vibration

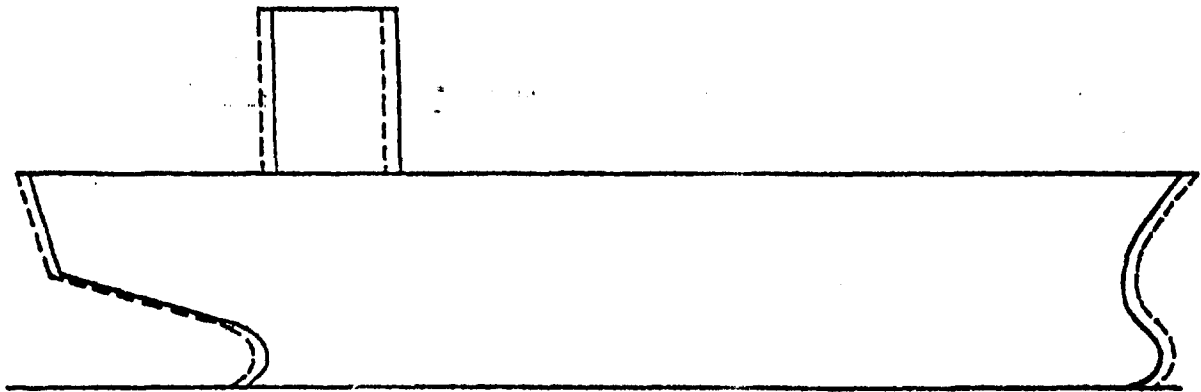

Figure 1-8
Hull Girder Longitudinal Vibration

As a general rule, the fundamental vertical mode may be as low as 1 Hz while the higher modes will follow the fundamental frequency by the ratios 1, 2, 3, 4, etc., as indicated on Figure 1-9, from Det Norske Veritas Guidelines [1-2].

Horizontal flexural frequencies follow a similar pattern. However, the fundamental (two noded) frequency will be approximately 50 percent higher than the fundamental vertical frequency.

The fundamental torsional mode of the hull girder may be estimated at approximately twice the horizontal or three times the first vertical natural frequency.

The longitudinal natural frequency may be estimated to be approximately three and one half times the fundamental horizontal mode.

1.3.2.3 Effects of Adverse Operating Conditions

Adverse operating conditions frequently result in significant increase in vibration amplitudes. When reporting shipboard vibration, or responding to reported problems, it is extremely important to recognize that shipboard vibration is a somewhat random phenomenon and the operating conditions must be reported for the data given. This factor also has a significant impact on the analysis and reporting of data used for evaluation purposes. Details are given under Chapter 6.0, Measurement Methods. Some relevant factors are given below:

1.3.2.3.1 Sea Conditions. Under ideal sea conditions (flat calm, straight ahead) hull vibration signals will modulate from maximum to minimum by a factor of 2 to 1.

Under prescribed trial conditions (sea state 3 or less) hull vibration signals may modulate by a factor of 3 to 1. Higher factors may exist under adverse weather conditions.

1.3.2.3.2 Hard Maneuvers. During hard turns, amplitudes may readily increase by a factor of two for single screw ships and a factor of three for twin screw ships.

During a crashback (full ahead to full astern), the alternating thrust may exceed the driving thrust and can result in damage to the thrust bearings if care is not exercised. It is prudent to first check this procedure at lower speed conditions while monitoring the thrust bearing response. This precautionary note is recommended for all sea trials.

1.3.2.3.3 Shallow Water. An increase in hull vibration by 50 percent may be experienced in shallow water. Shallow water in this context is a depth of less than six times the draft of the ship.

1.3.2.3.4 Light Draft Condition. An increase in hull vibration by 25 percent may be experienced in ballast condition. For minimum hull vibration, full load with aft peak tanks filled is recommended.

Ship Vibration Design Guide

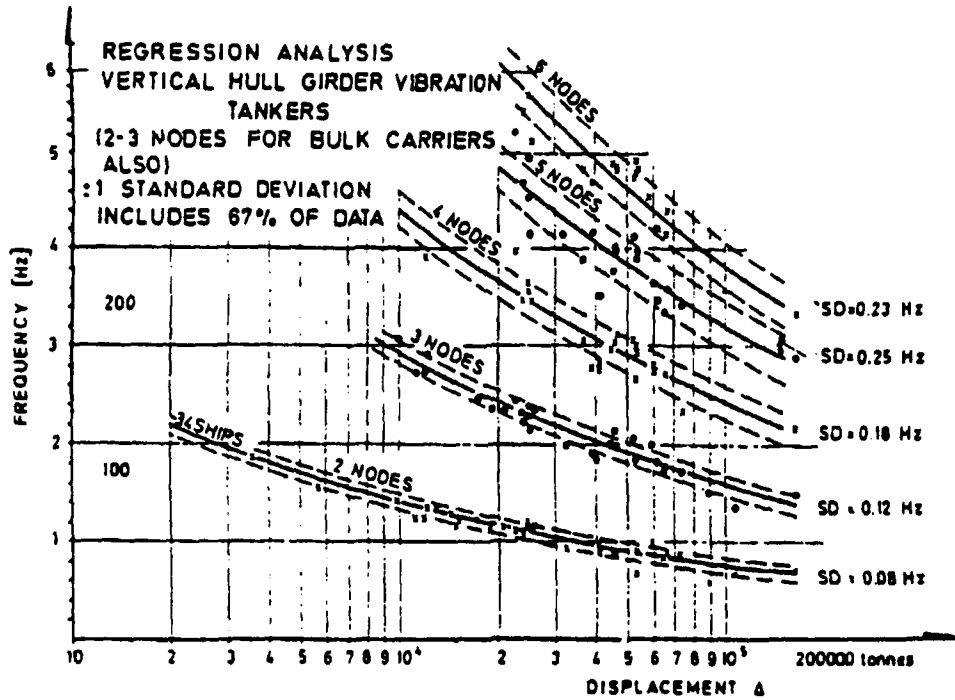
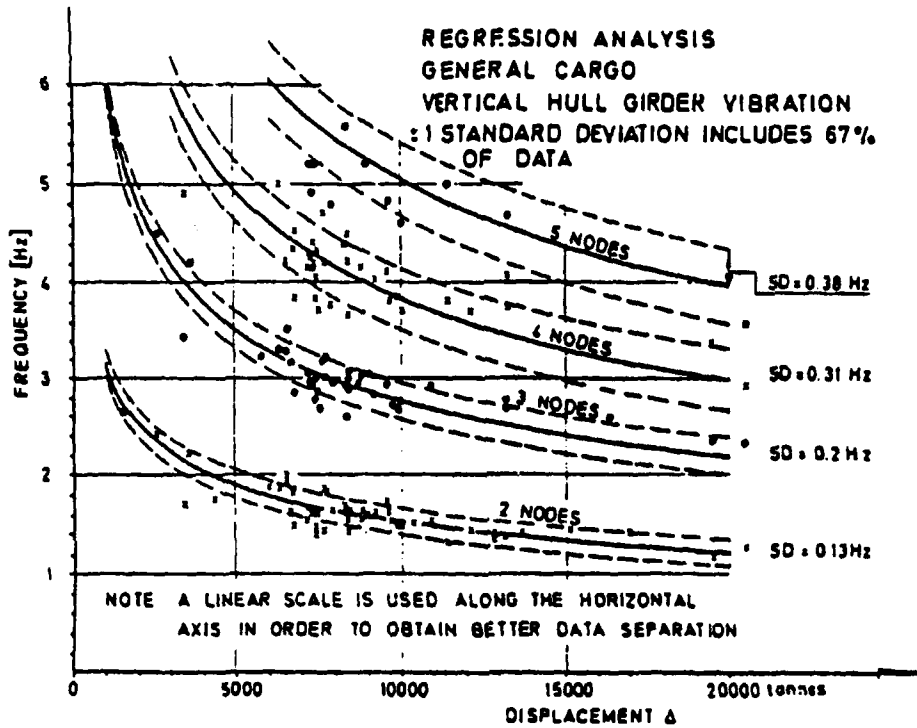

Figure 1-9
Plots of Hull Girder Vertical Vibration

1.4 Vibration of Major Substructures

For purposes of evaluation, major substructures are defined as secondary structures of sufficient mass or force generating ability to have dynamic characteristics of their own, which, because of the direct coupling with hull girder vibration, can significantly influence the total or global pattern of ship vibration. In analyzing vibration patterns of such large complex structures, it is necessary to identify the principal reason for observed excessive vibration. Although the excitation of the substructure generally originates at its attachment to the hull girder, excitation can come from machinery or active equipment mounted to major substructure. Excessive vibration of a major substructure may be the result of structural resonances in the substructure or in the attachment detail for the substructure and hull girder. Depending on the mass involved and method of attachment, major substructure can sometimes amplify the response of the hull girder.

The best way to evaluate the vibratory characteristics of a major substructure would be by means of a finite-element analysis. However, since this is generally not available for the preliminary design phase, the use of typical common system frequencies, as included in Appendix 1-A, is useful at that time.

Typical major substructures would include deckhouses; main deck structures; large propulsion machinery systems, particularly large slow diesels and other heavy installations, including their foundations, such as boilers, reactors, large weapon systems, rudders, etc.

Figure 1-10 shows some possible modal patterns of vibration frequently found in aft deckhouse structures when excited by flexural and longitudinal vibration of the hull girder. Those shown indicate longitudinal vibration and include:

- Superstructure shear deflection
- Superstructure bending deflection
- Superstructure support deflection with rigid body motion
- Vertical hull girder vibration
- Longitudinal hull girder vibration

The dynamic response characteristic of the superstructure is primarily a function of superstructure shear stiffness, supporting structure vertical stiffness and the degree of coupling to hull girder modes. The superstructure rigid body motion is mostly due to hull girder response.

The avoidance of superstructure vibration problems generally requires a structural designer of considerable experience. A finite-element analysis of the aft portion of the ship, with the forward portion represented by the balance of a 20 station beam, has been found to be a considerable help in determining aft deckhouse response. Such analysis should be conducted as early as possible.

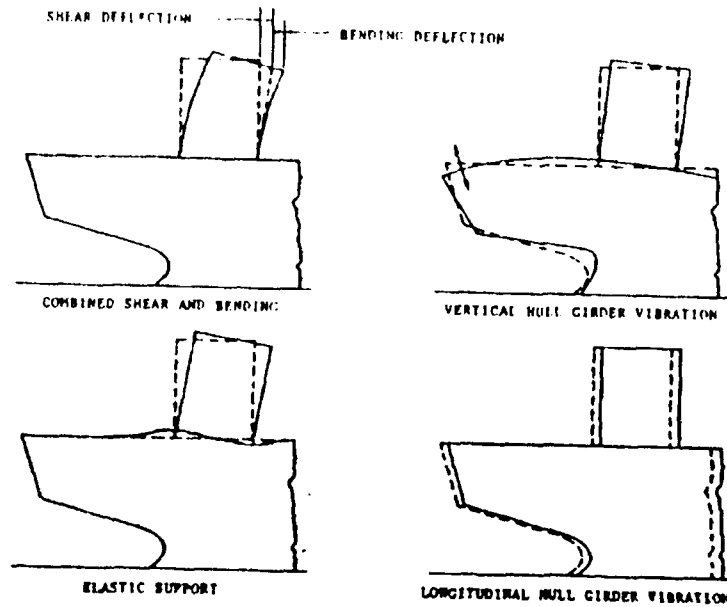

Figure 1-10

Superstructure Longitudinal Vibration

1.5 Vibration of Local Structural Elements

A local structural element is a minor structural assembly, relative to major substructures previously referred to. Local structure may be identified as panels, plates, girders, bulkheads, platforms, handrails, minor equipment foundations, etc. and are components of larger structures (major substructures) or of the hull girder. Most problems encountered aboard ship occur in local structural elements and are the result of either strong inputs received from the parent structure amplified by resonance effects in the local structure or are the response to vibratory forces generated by mechanical equipment attached to the local structure. In some cases, problems are generated by the improper attachment of shipboard equipment, even when the equipment has no self-exciting forces (passive equipment).

During the design of the ship, details of local structural elements and methods of installation of shipboard equipment are frequently based on practical experience and dynamic analyses are rarely performed. Although this approach is satisfactory in most cases, many problems arise or result from subsequent modifications. Most shipboard vibration problems fall in this category and are generally amenable to easy and simple solutions once an understanding of the problem is obtained.

1.6 Vibration of Shipboard Equipment

Shipboard equipment is defined as all equipment installed aboard ship as a permanent part of the total ship system. It may contribute to the propulsion system, auxiliary, communication, control, or life support systems, and will include joiner work and furniture. For convenience, all such equipment is classified as "passive" or "active." With regard to vibration problems of shipboard equipment, it is useful to separate the two.

1.6.1 Passive Shipboard Equipment

Passive equipment is all shipboard equipment permanently attached to the ship structure but which has no moving parts and/or produces no exciting forces. Typical examples would include heat exchangers, radio equipment, switchboards, joiner work, furniture, piping, etc. Excessive vibration of such equipment could be damaging to the equipment and adversely affect the operation of the unit or the system of which it is a part. In most cases, specific environmental limitations exist, whether identified or not. In some cases, vibration limitations are established for shipboard equipment, particularly with naval equipment. At the present time, international standards are under consideration for qualification of commercial shipboard equipment subject to environmental vibration. Equipment which is sensitive to vibration, such as electronic equipment, is frequently installed on resilient mountings. A common difficulty arises from an improper selection of mountings.

In the evaluation of shipboard vibration as it affects passive shipboard equipment, the same approach is recommended as is used for the vibration of local structural elements. The vibration encountered is normally associated with the response of the supporting structure and may be related to the main propulsion system, to the forces generated by nearby machinery, or to an ancillary device directly attached to a machine (such as a gage on a diesel engine). As in the previous case, the problem results from strong input forces and/or a resonant magnification from the attachment method or internal mechanical characteristics.

1.6.2 Active Shipboard Equipment

In contrast to the characteristics of passive shipboard equipment, active shipboard equipment (e.g., pumps, compressors, generators) have moving parts that frequently include sufficient mass to produce vibratory forces, which when combined with the dynamic characteristics of the supporting structure, would be capable of creating problems when operating. Support systems for equipment may also include resilient mountings that can reduce the transmission of self generated forces to the supporting structures but which can also amplify the low frequency vibration generated by the ship's propulsion system.

The principal problems associated with the vibration of active shipboard equipment relates to the forces generated by the equipment itself and those transmitted to the equipment through the ship's structure. These forces can usually be distinguished by the different frequencies present. The supporting structure and associated mounting system can generally be modified, if necessary, without great difficulty.

1.7 Vibration of Main Propulsion Machinery

The main propulsion machinery includes all components from the engine up to and including the propeller, and thus contributes to the vibration of the ship and to dynamic stresses within the propulsion system itself by forces generated both by the propeller and by the propulsion system components. The propeller forces and their effect on hull vibration were discussed previously. In this section we will discuss dynamic forces generated by the propulsion system and the effect of these forces on the vibratory characteristics of the total propulsion system.

Ship Vibration Design Guide

Dynamic stresses within the system and within the system components is a major concern. The control of dynamic forces generated by the propulsion system contributes to the vibratory characteristics of the total ship. Although the vibration of both the ship's hull and main propulsion machinery are interrelated, it is convenient, both in preliminary design studies, and in the control of shipboard vibration, to conduct independent studies on the propulsion system. It is necessary, however, to include actual or empirical factors related to the ship's structure, which form an important part of the effective mass-elastic system under study. In particular, the stiffness of the thrust bearing foundation is critical when evaluating the response of longitudinal vibration of the propulsion system.

The main areas of concern that can give rise to troublesome vibration or dynamic stresses include:

- Dynamic Unbalance and Misalignment
- Dynamic Shaft Stresses
- Longitudinal Vibration
- Torsional Vibration
- Lateral Vibration

The following sections will cover the above topics and include both the excitation and response of the propulsion system.

1.7.1 Dynamic Unbalance and Misalignment

Dynamic and/or hydrodynamic unbalance of the propeller, dynamic unbalance of shafting, bull gears, and other large components of the propulsion system operating at propeller shaft speed may contribute to objectionable hull vibration, particularly if the exciting frequency falls in resonance with a natural frequency of the hull. Such difficulties may also arise from the primary (1st order) or secondary (2nd order) unbalanced forces in large, slow-speed diesel engines or from serious shaft misalignment (1st order).

It is generally true, however, that the vibration occurring at these low frequencies (1st or 2nd order) will be particularly objectionable to humans when operating at the lower hull resonances. Vibration that exceeds the recommended criteria should be corrected to prevent local damage and/or excessive bearing wear. Specific corrective action may be required to control primary and secondary unbalances in slow-speed diesel engines.

Specific unbalance tolerances or machine vibration limits of high-speed components, such as turbines and compressors, are normally established by the manufacturer. When the vibration of such units exceed recommended criteria it may result in potentially dangerous problems with the equipment itself or may cause resonances of local foundations, attached piping, or components. In the absence of manufacturers' criteria, the criteria given in this guide should be used. Care should be exercised to distinguish between hull-excited and machine-excited vibration in order to properly determine corrective action required.

1.7.2 Dynamic Shaft Stresses

Propulsion shafting is normally designed in accordance with Classification Society Rules (ABS, Lloyds, etc.), and in some instances, by Navy rules [1-6]. With normal design practice, periodic inspections, and proper maintenance procedures no difficulty should be experienced with propulsion shafting during the life of the ship. However, experience has indicated serious difficulties, including shaft failure, can happen under normal operating conditions [1-4].

Shaft problems are related to dynamic stresses that in most cases, are exacerbated by corrosion fatigue. Such problems may be caused by the eccentric thrust, precipitated by adverse flow conditions at the propeller, and aggravated by misalignment and/or faulty shaft seals. Excessive stresses associated with torsional vibration in slow-speed diesel engine drives is also a potential problem area.

As a minimum, the complete propulsion system should be evaluated for acceptable steady and dynamic stress levels during the design phase, and verified during ship trials. Maintenance procedures should check for corrosion and fatigue cracks at the propeller keyway and at the shaft near the forward end of the propeller hub. Bearing wear and wear of shaft seals should also be checked.

1.7.3 Longitudinal Vibration

The propulsion system may exhibit excessive longitudinal vibration caused by alternating thrust generated by the propeller at blade frequency or harmonics of blade frequency. The vibration is considered excessive if it exceeds machinery criteria and can be particularly damaging to thrust bearings and/or reduction gears. Depending on structural characteristics, the alternating thrust forces transmitted to the ship through the thrust bearing can cause serious local vibrations in the engine room and to serious superstructure fore and aft response. Figure 1-11 shows the longitudinal vibration of a typical propulsion shaft. The addition of the main engines and reduction gears to the mass-elastic system is required for complete evaluation. The forces transmitted to the ship's structure are primarily dependent on the total mass of the system shown in Figure 1-11 and the combined thrust bearing and foundation stiffness.

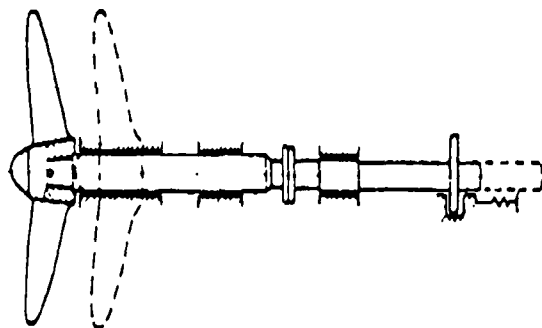

Figure 1-11

Longitudinal Vibration of Shafting System

Ship Vibration Design Guide

In general, longitudinal and torsional vibrations of propulsion systems may be considered as independent of one another, but this is not always the case. The propeller couples the longitudinal and torsional degrees of freedom of the system to some extent under all conditions, but the coupling effect is significant primarily when the independent critical frequencies are close to one another. In such cases the mode excited is actually a longitudinal-torsional mode and the excitation involves a generalized force, which includes both torque and thrust variations. This phenomenon is of particular concern with diesel drive systems.

While longitudinal vibration may be observed aboard ship, to properly instrument and evaluate against the various criteria will require a dynamic analysis for correlation purposes and, in most cases, further analyses to determine optimum corrective action. Vibration specialists should be obtained for such problems and for total system evaluation during ship trials.

1.7.4 Torsional Vibration

Torsional vibration of the propulsion system may be excited by the alternating torque produced by the propeller and/or the engine harmonics in a diesel drive system. Ordinarily torsional resonances within the shafting system shown in Figure 1-12 does not produce serious vibration problems in the ship's structure although they can produce damaging effects in reduction gear drives, particularly under adverse sea conditions. In diesel engine drive system of all types, torque reactions can be a major structural vibration concern. Additionally, torsional resonances can be damaging to system components.

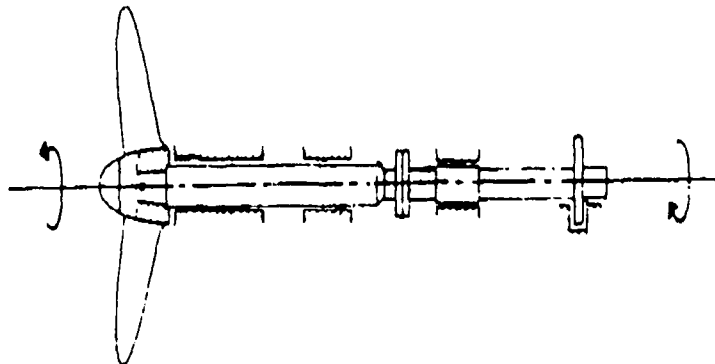

Figure 1-12

Torsional Vibration of Typical Shafting System

Although the evaluation of torsional vibration of the shafting is subject to classification rule requirements, it is also considered necessary to carry out a torsional vibration analysis of the complete propulsion system in the design phase and verify the system response characteristics during ship trials. As in the case of longitudinal vibration studies, experienced personnel are considered necessary for the evaluation and resolution of shipboard problems. For more detailed information on the subject see "Practical Solutions of Torsional Vibration Problems" [1-8] and "BICERA" [1-9].

1.7.5 Lateral Vibration

The propulsion shaft system, Figure 1-13, is normally designed so that the fundamental lateral or whirling critical speed is well above the running speed. Background information and calculation procedures are given by Jasper [1-10], Panagopulos [1-11], and Navy Design Procedures [1-6]. The fundamental mode of vibration is referred to as "forward whirl" and is excited by mass unbalance, and at resonance poses a serious danger to the propeller shaft system. The frequency of the system is significantly influenced by the effective point of support of the aft bearing and the stiffness of the bearing supports.

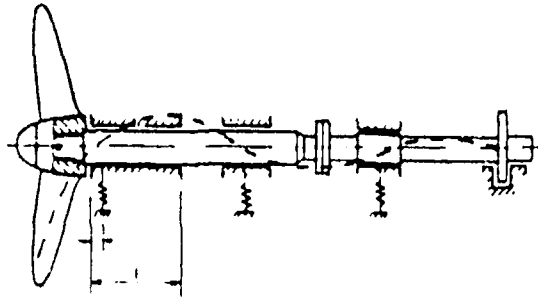

Figure 1-13

Whirling Vibration of Shafting

Figure 1-14, taken from Det Norske Veritas guidelines [1-2] shows the influence of the position of the aft bearing support on the frequency of the whirling critical.

Misalignment or serious bearing wear can result in high dynamic stresses in the shaft, dynamic magnification of bearing reactions and increased hull vibration, and overheating. On the assumption that the design was satisfactory initially, good maintenance is required to keep it that way. The use of roller bearings or self aligning bearings, and attention to dynamic balance will minimize potential problems.

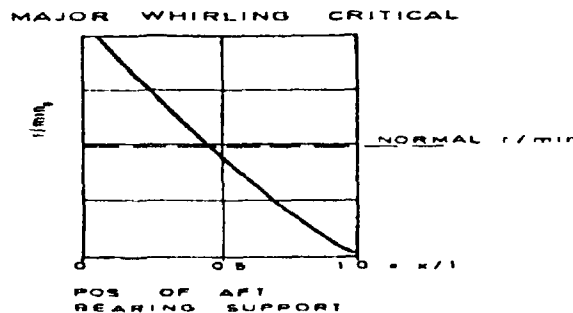

Figure 1-14

Position of Aft Bearing Support

REFERENCES

- 1-1 Noonan, E. F., "An Assessment of Current Shipboard Vibration Technology," Ship Structures Symposium, 1975, S.N.A.M.E. Publication SY-5.
- 1-2 Det Norske Veritas Guidelines, "Prevention of Harmful Vibration in Ships," May, 1980
- 1-3 Bureau Veritas, "Recommendations Designed to Limit the Effects of Vibration on Board Ships," 1979.
- 1-4 Noonan, E. F., "Propeller Shaft Bending Stresses on the S.S. Esso Jamestown," Journal of the A.S.N.E., August, 1961.
- 1-5 Huse, E., "Propeller-Hull Vortex Cavitation," Norwegian Ship Model Experimental Tank Publication No. 106, May, 1971.
- 1-6 Department of the Navy, Bureau of Ships, Interim Design Data Sheets, DDS-4301, "Propulsion Shafting," 1 Jan., 1960.
- 1-7 "A Statistical and Economic Evaluation of Stern Tube Bearing and Seal Failures," MTI, Inc., Report No. MA-RD-940-77091, July, 1977.
- 1-8 Wilson, W. Ker., "Practical Solution to Torsional Vibration Problems," Chapman and Hall, Ltd., London, 1963, (Two Volumes).
- 1-9 B.I.C.E.R.A., "A Handbook on Torsional Vibration," Cambridge University Press, 1958.
- 1-10 Jasper, N.H., "A Design Approach to the Problem of Critical Whirling Speeds of Shaft-Disc Systems," D.T.M.B. Report 890, Dec. 1954.
- 1-11 Panagopoulos, E.P., "Design Stage Calculations of Torsional, Axial, and Lateral Vibration of Marine Shafting," Trans. S.N.A.M.E., Vol. 58, 1950.

APPENDIX 1-A

Table 1-A-1 Natural Frequencies of Common Systems

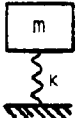
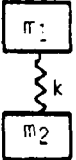
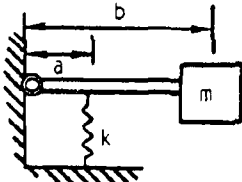
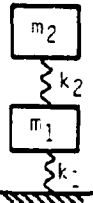
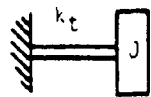
<u>MODEL</u>	<u>SKETCH</u>	<u>NATURAL FREQUENCY, HZ</u>
1. Single mass and spring		$f_n = \frac{1}{2\pi} \sqrt{\frac{k}{m}}$
2. Two masses, one spring		$f_n = \frac{1}{2\pi} \sqrt{\frac{k(m_1 + m_2)}{m_1 m_2}}$
3. Single cantilevered mass		$f_n = \frac{L_1}{2\pi L_2} \sqrt{\frac{k}{m}}$
4. Two mass, two spring		$f_n = \frac{1}{4\pi} \left[\frac{k_1}{m_1} + \frac{k_2}{m_2} \left(1 + \frac{m_2}{m_1} \right) \pm \sqrt{\left[\frac{k_1}{m_1} + \frac{k_2}{m_2} \left(1 + \frac{m_2}{m_1} \right) \right]^2 - \frac{4k_1 k_2}{m_1 m_2}} \right]$
5. One rotor and shaft		$f_n = \frac{1}{2\pi} \sqrt{\frac{k_t}{J}}$

NOTE: Similar to Model No. 1. Two rotor systems are similar to Model No. 2 or 4.

Ship Vibration Design Guide

Table 1-A-1 Natural Frequencies of Common Systems (continued)

MODEL	SKETCH	NATURAL FREQUENCY, HZ
6. Rectangular plate, simply supported edges		$f_n = 8.91 H \left(\frac{1}{L_1^2} + \frac{1}{L_2^2} \right) \sqrt{\frac{E}{(1 - \nu^2) \rho}}$ <p>For Steel:</p> $f_n = 9.7 \times 10^4 H \left(\frac{1}{L_1^2} + \frac{1}{L_2^2} \right)$
7. Rectangular plate, clamped edges		<p>For Steel:</p> $f_n = 8.2 \times 10^4 \frac{H}{L_1 L_2} \sqrt{7 \left(\frac{L_1^2}{L_2^2} + \frac{L_2^2}{L_1^2} \right) + 4}$
8. Longitudinal vibration of beam (fixed or free ends)		$f_n = \frac{9.82}{L} \sqrt{\frac{E}{\rho}}$ <p>for Steel or Aluminum:</p> $f_n = \frac{10^5}{L}$
9. Longitudinal vibration of beam (fixed-free)		$f_n = \frac{1.57}{2\pi} \sqrt{\frac{AE}{\rho L^2}}$
10. Fixed-Free beam mass at end		$f_n = \frac{1}{2\pi} \sqrt{\frac{3EI}{L^3 (m + .23 m_b)}}$

Table 1-A-1 Natural Frequencies of Common Systems (continued)

MODEL	SKETCH	NATURAL FREQUENCY, HZ
11. Hinged-Hinged beam mass in center		$f_n = \frac{1}{2\pi} \sqrt{\frac{48EI}{L^3 (m + .5 m_b)}}$
12. Fixed-Fixed beam mass in center		$f_n = \frac{7}{\pi} \sqrt{\frac{EI}{L^3 (m + .375 m_b)}}$
NOTE: For Models 10-12, set $m_b = 0$ for massless beams.		
13. Hinged-Hinged beam, off-center mass, massless beam		$f_n = \frac{1}{2\pi L_1 L_2} \sqrt{\frac{3EI}{m}}$
14. Fixed-Fixed beam, off-center mass, massless beam		$f_n = \frac{1}{2\pi} \sqrt{\frac{3EI L^3}{m L_1 L_2}}$
15. Uniform beam, fixed-free		$f_1 = \frac{A_1}{2\pi} \sqrt{\frac{EI}{\mu L^4}}$
16. Uniform beam, hinged-hinged		$f_1 = \frac{A_1}{2\pi} \sqrt{\frac{EI}{\mu L^4}}$

Ship Vibration Design Guide

Table 1-A-1 Natural Frequencies of Common Systems (continued)

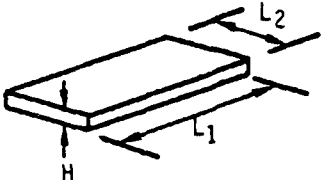
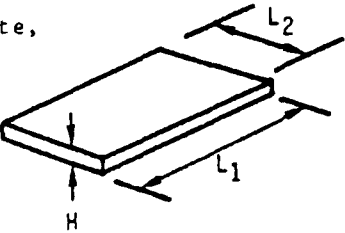
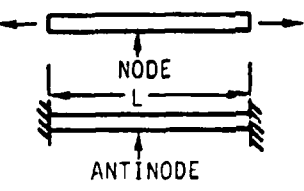
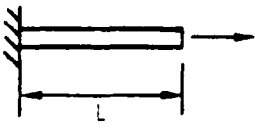
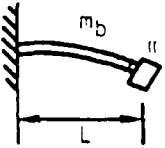
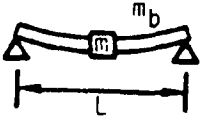
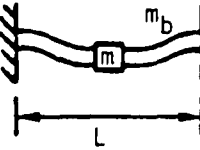
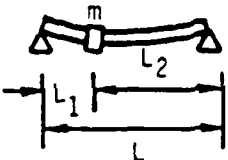
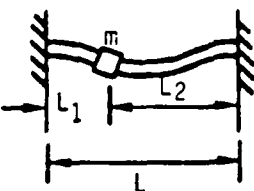
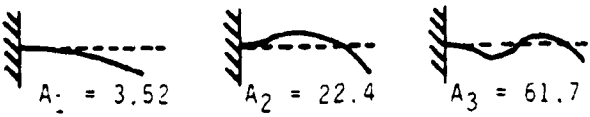
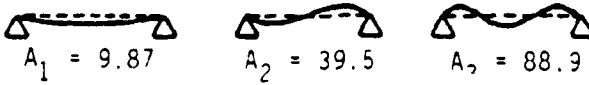
MODEL	SKETCH	NATURAL FREQUENCY, HZ
17. Uniform beam, fixed-fixed		$f_1 = \frac{A_1}{2\pi} \sqrt{\frac{EI}{\mu L^4}}$
18. Uniform beam, free-free		$f_1 = \frac{A_1}{2\pi} \sqrt{\frac{EI}{\mu L^4}}$
19. Uniform beam, fixed-hinged		$f_1 = \frac{A_1}{2\pi} \sqrt{\frac{EI}{\mu L^4}}$
20. Uniform string in tension		$f_1 = \frac{A_1}{2L} \sqrt{\frac{P_s}{\mu}}$
21. Massless string, mass in center		$f_n = \frac{1}{\pi} \sqrt{\frac{P_s}{mL}}$
22. Pendulum		$f_n = \frac{1}{2\pi} \sqrt{\frac{g}{L}}$

Table 1-A-2 Stiffness of Common Structures

<u>MODEL</u>	<u>SKETCH</u>	<u>STIFFNESS</u>
1. Parallel springs		$k = k_1 + k_2$
2. Series springs		$k = \frac{k_1 k_2}{k_1 + k_2}$
3. Solid shaft (torsion)		$k_t = \frac{\pi G D^4}{32 L}$
4. Hollow shaft (torsion)		$k_t = \frac{\pi G (D_o^4 - D_i^4)}{32 L}$
5. Rectangular (torsion)		$k_t = \frac{G W H^3}{3 L}$
6. Cantilever beam		$k = \frac{3 E I}{L^3}$
7. Simply supported beam (center load)		$k = \frac{48 E I}{L^3}$

Ship Vibration Design Guide

Table 1-A-2 Stiffness of Common Structures (continued)

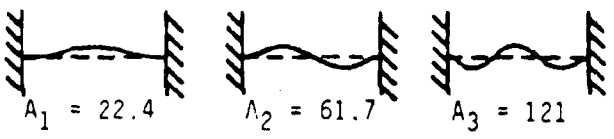
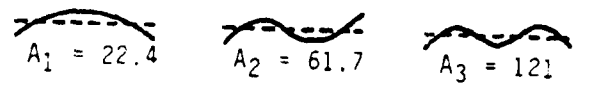
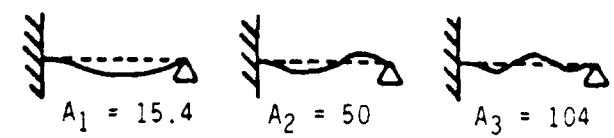
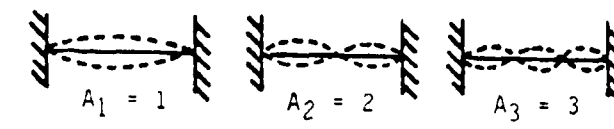
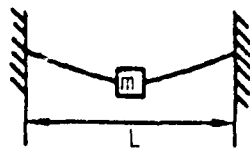
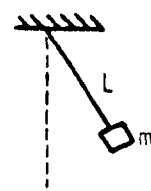
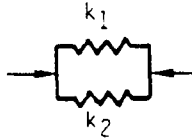
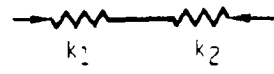
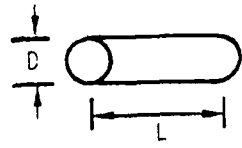
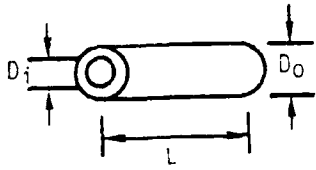
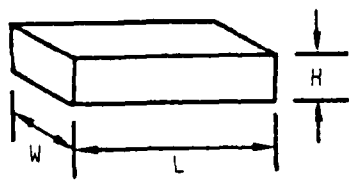
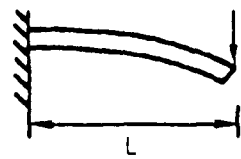
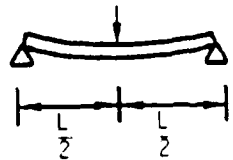
<u>MODEL</u>	<u>SKETCH</u>	<u>STIFFNESS</u>
8. Fixed-Fixed beam (center load)		$k = \frac{192EI}{L^3}$
9. Simply supported beam (off-center load)		$k = \frac{3EIL}{L_1^2 L_2^2}$
10. Helical spring		$k = \frac{Gd^4}{8nD_s^3}$
11. String in tension		$k = \frac{4P_s}{L}$
12. Axial stiffness of beam		$k = \frac{AE}{L}$
13. Torsional stiff- ness of beam		$k_t = \frac{GI_p}{L}$

Table 1-A-3 Moments of Inertia of Common Cross Sections

<u>CROSS-SECTION</u>	<u>SKETCH</u>	<u>I (WITH RESPECT TO AXIS SHOWN) OR I_p</u>
Circle		$I = \frac{\pi D^4}{64}$
Hollow Circle		$I = \frac{\pi}{64} (D_o^4 - D_i^4)$ $I_p = \frac{\pi}{32} (D_o^4 - D_i^4)$
Thin Wall Circle		$I = \frac{\pi D_o^3 H}{8}$ $I_p = \frac{\pi D_o^3 H}{4}$
Rectangle		$I = \frac{WH^3}{12}$

Notation for Appendix 1-A

m	=	Mass lb-sec ² / in, weight / g
k	=	Translational Stiffness, lb / in
J	=	Mass Moment of Inertia, lb-in-sec ²
E	=	Young's Modulus, lbs / in ²
ν	=	Poisson's Ratio
ρ	=	Weight Density, lbs / in ³
m_b	=	Mass of Beam, lb-sec / sec ²
I	=	Area Moment of Inertia of Cross Section, in ⁴
I_p	=	Area Polar Moment of Inertia of Cross Section, in ⁴
L	=	Length of Beam or String, in
μ	=	Mass per Unit Length, lb-sec ² / in ²
P_s	=	Tension in String, lb
A	=	Cross Section Area of Beam, in ²
g	=	Acceleratio Due to Gravity, 386.1 in / sec ²
G	=	Shear Modulus of Elasticity, lb / in ²

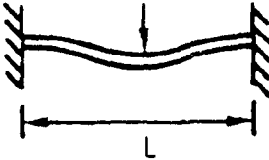
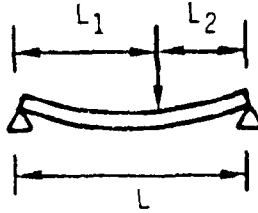
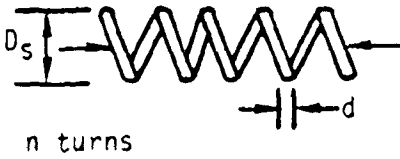
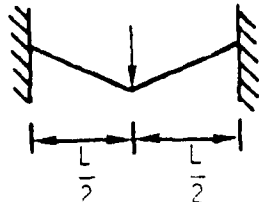
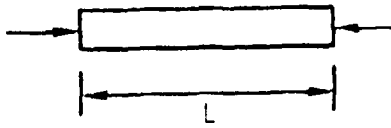
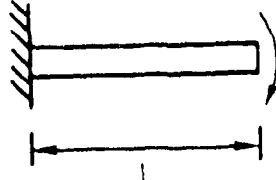
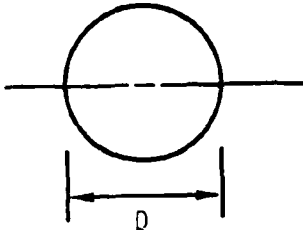
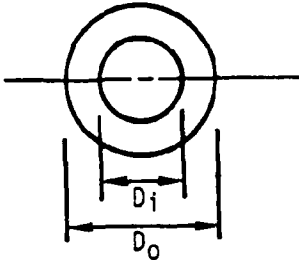
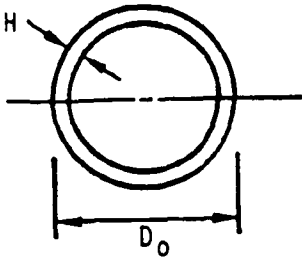
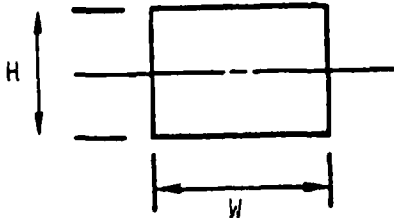
VIBRATION CRITERIA AND SPECIFICATIONS

The design objective of all new ship construction is to meet the criteria or specifications invoked for that project. To accomplish this, the performance requirements of the propulsion system and other functional shipboard systems must all be carefully specified. To control and/or to minimize shipboard vibration, it is also necessary to stipulate applicable criteria in specification format. The use of general requirements, such as: "Shipboard vibration should be limited to acceptable levels," or "A good dynamic balance is required," has little or no value in practice and frequently leads to expensive litigation and/or major design changes. Since such problems are generally not encountered until the ship is undergoing trials, the results can be devastating.

It is the purpose of this chapter to provide guidance in the form of suitable criteria, which when invoked in the form of ship specifications, represents a "line item" in the ship design cycle and thus provides the basis for the required design analyses to control shipboard vibration. The importance of this approach, together with specific examples, was demonstrated at the 51st Shock and Vibration Symposium in September, 1980, [2-1].

In developing vibration specifications (design criteria) to be used in the control of shipboard vibration, of paramount concern are those periodic forces developed by the ship's machinery systems and the response of hull structure and machinery systems. In summary:

- Ships are excited by both transient and periodic forces.
- In most cases, transient forces are caused by rough seas.
- Most periodic forces are generated by propeller and machinery systems.
- Heavy transient forces, such as slamming, will excite structural resonances and can cause serious damage in heavy seas.
- Comparatively low periodic forces, when combined with resonant conditions, can cause serious shipboard vibration problems.
- Both transient and periodic forces are aggravated by heavy seas and hard maneuvers.
- This guide is directed toward the control and attenuation of vibration excited by periodic forces and does not relate to transient excitation.

Ship Vibration Design Guide

To properly evaluate shipboard vibration, it has been generally accepted that uniform test conditions should be employed for vibration trials, such as those specified in the SNAME T&R Code C-1, "Code for Shipboard Vibration Measurement," [2-9] and ISO 4867, "Code for the Measurement and Reporting of Shipboard Vibration Data" [2-6]. Thus, in the absence of other design requirements, a standard method of testing can be employed for all ships for evaluation against uniform criteria. It should be noted, however, that more serious vibration can be expected under adverse operating conditions and suitable factors must be included in the design of structural and mechanical components to account for the maximum anticipated dynamic stresses.

Shipboard vibration is considered excessive when it results in structural damage, damage or malfunction of vital shipboard equipment, or adversely affects the comfort or efficiency of the crew. Normally, crew complaints will occur before vibration becomes damaging to the ship's structure. However, failure or malfunction of vital shipboard equipment may occur without significant annoyance to the crew.

The criteria recommended in this guide are based on existing requirements related to:

- Human reaction (habitability)
- Machinery and equipment malfunction
- Fatigue failure

For convenience, the total ship system relates to the five basic elements defined in Chapter 1.0 in the following manner:

2.1 General Hull Vibration

Most shipboard vibration problems originate with the vibration of the hull (ship's girder). The recommended criteria relates to human reaction.

2.2 Major Substructures, Local Structures and Shipboard Equipment

These structures, which are attached to and excited by the hull girder, can relate to all three criteria.

2.3 Machinery Vibration

In most instances, machinery vibration relates to malfunction or fatigue failure of components.

2.1 General Hull Vibration

The recommended criteria for general hull vibration is based on human reaction to the vibration aboard ship in normally occupied spaces of the hull and superstructure. The criteria shown in Figure 2-1 is based on maximum repetitive values (peak values) for each component such as shaft frequency, propeller blade frequency, or harmonics of propeller blade frequency, and is

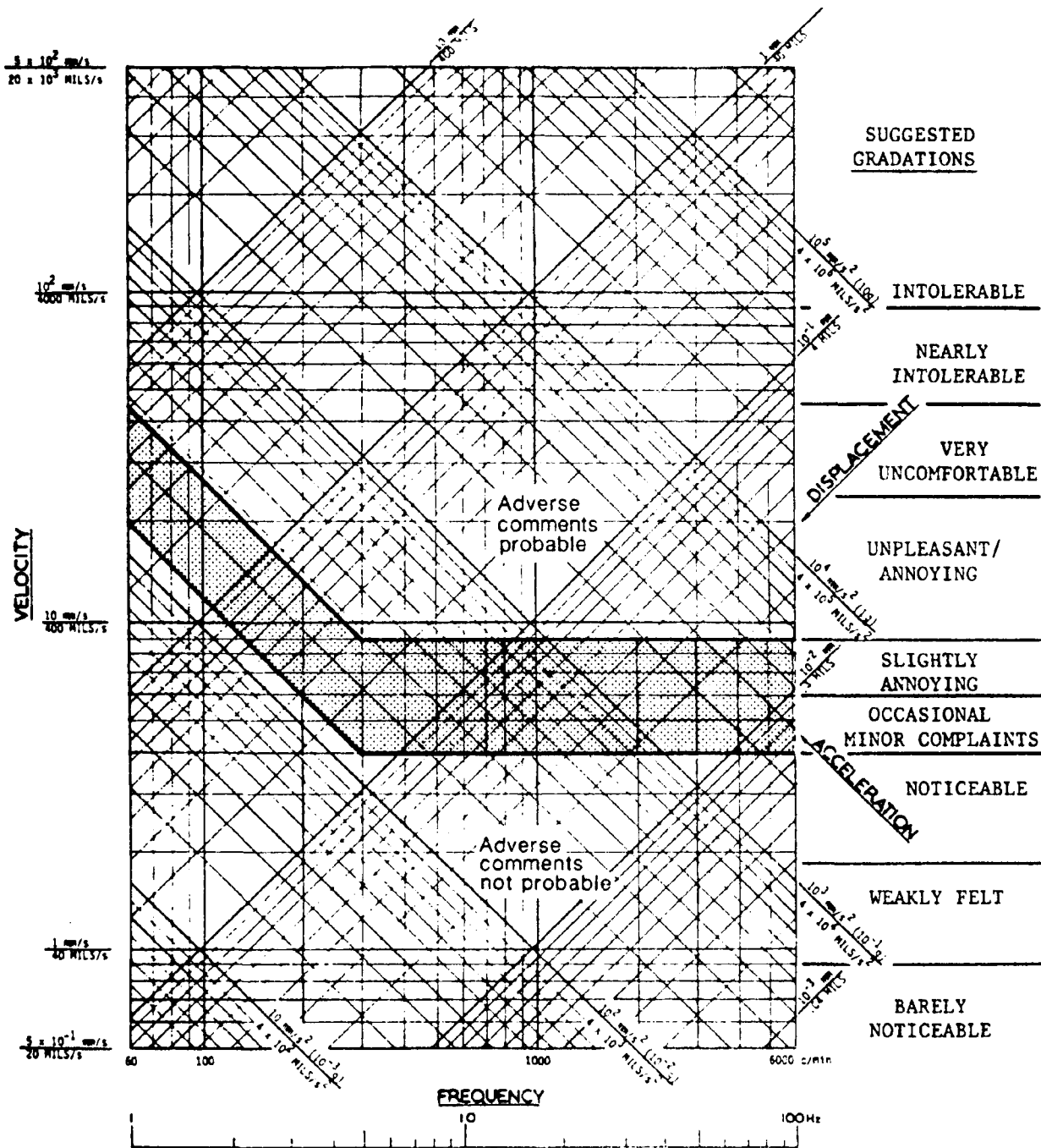

Figure 2-1

Guidelines for the Evaluation of Vertical and Horizontal Vibration in Merchant Ships

Ship Vibration Design Guide

identical to those in ISO 6954 and SNAME T&R Bulletin 2-25. The curves shown from [2-2] and [2-3] are in both metric and English units.

For convenience of interpretation, Figure 2-2 shows a linear displacement plot of a 4 mm/sec or 0.16 in/sec constant velocity curve, which represents the lower limit of the shaded area of Figure 2-1 above 5 Hz. The 9 mm/sec or 0.36 in/sec velocity curve represents the upper limit of the shaded area of Figure 2-1, above 5 Hz. Below the 4 mm/sec curve, referred to as Zone 1 by the SNAME guidelines, adverse comments are generally unexpected. Above the 9 mm/sec curve, in Zone III, complaints are generally expected. Zone II, which represents the shaded area in the guideline curves, has been further divided by a 0.25 in/sec or 6.3 mm/sec curve to represent a finer evaluation of complaints received. It is recommended that vibration levels in Zone I be considered totally acceptable from 5 to 100 Hz. Vibration levels in Zone III generally are considered unacceptable. Vibration levels in the upper half of Zone II (above 0.25 in/sec or 6.3 mm/sec) may require further investigation if personnel are exposed to these levels for extended periods of time (above 8 hours). Below this curve, complaints should be considered of minor importance.

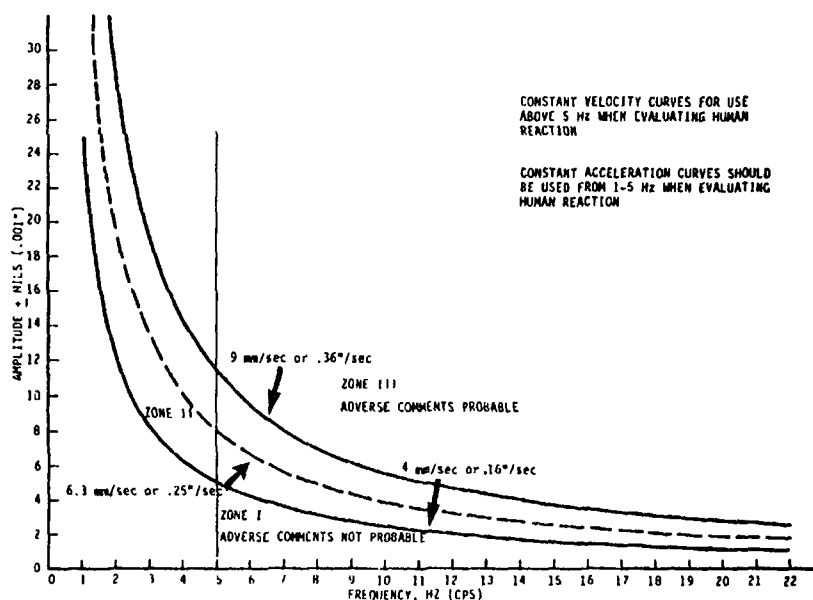

Figure 2-2

Guidelines for Ship Vibration - Vertical and Horizontal

Below 5 Hz, the ISO and SNAME guidelines for human reaction show constant acceleration curves of .013 g for the lower limit and .029 g for the upper limit. While the corresponding amplitudes below 5 Hz would be relatively high (greater than shown on the constant velocity curves of Figure 2-2), the normal excitation at that frequency would result from dynamic or hydrodynamic unbalance in the propulsion system with attendant hull resonances at certain operating speeds (RPM). In Great Lakes ships, which are long and slender, the fundamental frequency may be below 1 Hz and thus may be excited by wave energy that includes a frequency which produces springing or resonant vibration at the hull's natural frequency. The

vibration level would be high but the acceptable limit would be based on the total allowable hull-bending stress. Also see Section 2.2.4.1, Hull Girder Vibration (Springing).

The relatively high tolerance below 5 Hz, as shown on Figure 2-1, is generally required for ships driven by slow-speed diesels with large primary unbalanced forces and moments. For turbine-driven ships, it is normally feasible to continue the constant-velocity limits of 4 mm/sec and 9 mm/s down to 1 Hz since the residual unbalance in the propulsion system is much lower. Figure 2-2 shows these constant velocity curves on a linear plot.

As noted in Chapter 6.0, shipboard vibration is generally a narrowband random phenomena. A crest factor of 2.5 is commonly encountered during trial conditions. Maximum repetitive vibration is more appropriate than rms vibration to evaluate overall ship vibration. Both the SNAME guidelines and ISO 6954 evaluate overall shipboard vibration in terms of maximum repetitive values and, for comparison with rms values, the crest factor must be taken into account.

In ISO 2631, the effect of vibration on human beings is evaluated by referring to curves of rms acceleration and applying a wide range of crest factors. The guidelines recommended herein correspond to ISO 6954 and ISO 2631 with respect to crew exposure to whole body vibration provided that the upper band specified, when converted to rms acceleration with factors of 1.6 and 3.0, is below the criteria curves selected on the basis of ISO 2631 [2-4]. The relationship of these criteria is shown graphically in Figure 2-3.

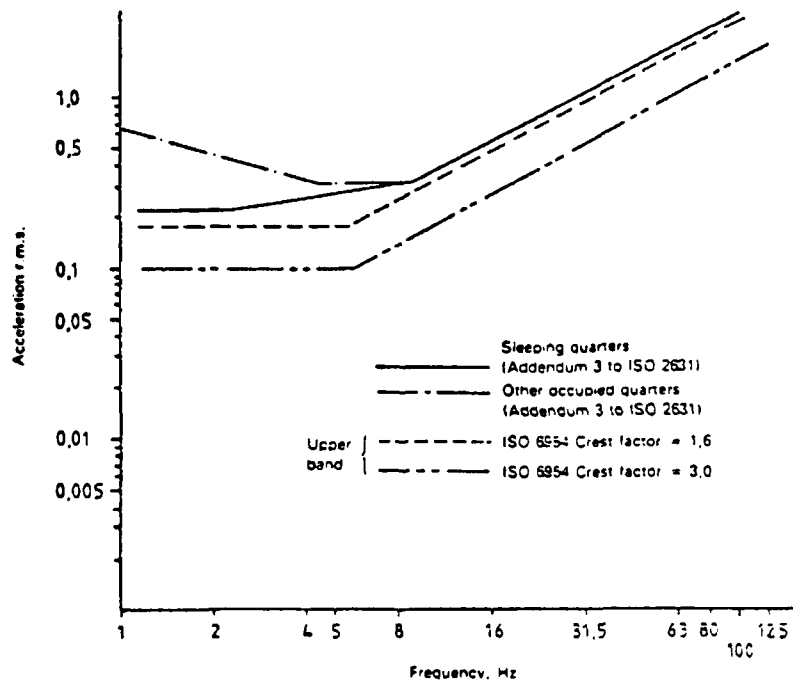

Figure 2-3

Comparison Between ISO 6954 and Addendum 3 to ISO 2631

2.2 Major Substructures, Local Structures And Shipboard Equipment

Based on the general philosophy expressed in Section 2.0, the complete ship system can be divided into a number of its basic elements for convenience in the diagnosis, evaluation and development of corrective actions to resolve shipboard vibration problems. In a similar manner, vibration criteria applicable to specific elements or problem areas can be developed. To accomplish this, major substructures and local structures are treated similarly since they both represent segments of the total ship structure with the hull girder acting as a vibrating platform on which these components are attached, frequently in a descending order of structural rigidity. Human reaction, equipment malfunction, and fatigue failure represent applicable design criteria.

2.2.1 Human Reaction

The criteria for human reaction throughout the ship remains the same for all areas designated as accommodations or working spaces. Major substructures, such as deckhouses or large deck areas, may magnify the basic hull vibration. Local structures, such as a compartment deck in the deckhouse, may further amplify the hull vibration. However, the same criteria for adequacy, based on human reaction, should be applied. Thus, all areas utilized for habitability purposes should meet the requirements recommended in Section 2.1 for general hull vibration.

2.2.2 Equipment Malfunction

Equipment malfunction or damage may occur as a result of the vibration of those structural components to which the equipment is attached or may be due to the sensitivity of the equipment. Examples of this include meters mounted on bulkheads, electronic equipment mounted on isolation mountings, binnacles mounted on the bridge deck, equipment mounted on a fabricated foundation, switchboard equipment, transformers, and steam piping. When considering the response of passive (non self-exciting) equipment that could result in malfunction or damage to the equipment installed in the ship, the structural adequacy of the support system and the adequacy of the equipment to perform its function in the shipboard vibration environment must be considered.

2.2.2.1 Structural Adequacy of Support System

The structural adequacy of the total support system for any shipboard mounted equipment must be related to the basic hull vibration and the capability of the equipment to adequately perform in a shipboard vibration environment. In Section 2.1 criteria for the evaluation of hull vibration was identified where vibration levels in Zone III, "Adverse Comments Probable," required further investigation if these guidelines were exceeded.

As a rule of thumb, it is recommended that the structural adequacy of the support system be based on the response of the local structure at the mounting point when the structure is loaded as it would be in service and vibration amplitude should not exceed that of the basic hull structure in that area by more than 50 percent. This limitation would prohibit structural resonance but would allow for some amplification by the local structure with reference to the input motion of the vibrating platform, the hull girder. Motion should be restricted to a

maximum of 13.5 mm/sec in the frequency range of 5 to 100 Hz, when the maximum recommended limit of 9 mm/sec occurs in the hull.

Frequently, excessive vibration of equipment may be directly related to the geometry of the structural support system and/or the improper use of resilient mountings, which produce a resonant response. Examples include a ship's binnacle located on an improperly supported deck section or a tall electronic chassis with resilient mountings placed too close together. In such cases, excessive vibration may result, although the observed amplitude at the structural base appears satisfactory. Appropriate corrective action could include modifications to the support system and/or the addition of supporting braces. Similar problems can occur within shipboard equipment, frequently resulting in damage or malfunction in service. Hence, it is considered necessary to ascertain whether the problem is one of resonant structure, faulty installation, or unsatisfactory equipment.

2.2.2.2 Vibration of Shipboard Equipment

Failure or malfunction of shipboard equipment subjected to shipboard vibration is not necessarily caused by excessive vibration at the point of support, as noted above. It has been well established that commercially available equipment, originally designed for stationary installations, frequently fail when used in the shipboard vibration environment. Resonance of components of the equipment must be avoided and the equipment should be qualified in vibration resistance for shipboard use.

To ensure consistency in vibration resistance requirements for shipboard equipment and machinery, the International Organization for Standardization (ISO/TC108/SC2/WG2 Vibration of Ships) has undertaken the development of a "Code for Vibration Testing of Shipboard Equipment and Machinery Components," which was approved as a Draft Proposal (ISO/DP) for vote and comments, by SC 2, 3 April, 1987. WG2 N51, Oct. 1986 is based, in part, on MIL-STD-167-1 (SHIPS), Mechanical Vibration of Shipboard Equipment, Type 1, Environmental, and is consistent with the basic environmental testing procedures outlined in IEC Publication 68-2-6, Fifth Edition, 1982, which has as its objective, "to provide a standard procedure to determine the ability of components, equipment, and other articles to withstand specified severities of sinusoidal vibration."

When designing the installation of shipboard equipment and machinery components to meet shipboard vibration requirements, it is necessary to determine:

1. That the rigidity of the supporting structure is adequate;
2. That the method of attachment to the supporting structure will not result in excessive motion (resonance);
3. That the equipment itself has been qualified for shipboard use.

To assist in the evaluation of the vibration resistance of lightweight shipboard equipment and machinery components under study, proposed test procedures and test requirements are provided in Section 2.2.3. It should be noted, however, that these test requirements represent

an accelerated vibration test to simulate the environmental vibration that may be encountered aboard ships under adverse conditions. Vibration levels recorded on a ship during vibration trials will be lower than the levels shown in Table 2-1. The amplitudes specified for the environmental tests are sufficiently large within the selected frequency range to obtain a reasonably high degree of confidence that equipment will not malfunction under the most severe service conditions.

2.2.3 Environmental Testing of Shipboard Equipment

The test specified herein is intended to locate resonances of the equipment and impose an endurance test at each of these resonances. Equipment that passes this test will have a greater probability of satisfactory performance aboard ships.

2.2.3.1 Vibration Tests

Equipment vibration tests shall be conducted separately in each of the three principal directions of vibration. All tests in one direction shall be completed before proceeding to tests in another direction. The equipment shall be secured to the vibration table and shall be energized to perform its normal functions. If major damage occurs, the test shall be discontinued and the entire test shall be repeated following repairs and correction of deficiencies, unless otherwise directed by the agency concerned. The manufacturer may, at his option, substitute an entirely new piece of equipment for retest. If this option is taken, it shall be noted in the test report.

2.2.3.2 Exploratory Vibration Test

To determine the presence of resonances in the equipment under test, the equipment shall be secured to the vibration table and vibrated at frequencies from 2 Hz (or lowest attainable frequency) to 15 Hz, at a table vibratory amplitude of ± 1.0 mm. For frequencies from 15 to 100 Hz, the equipment shall be vibrated at an acceleration level of ± 0.9 g. The change in frequency shall be made in discrete intervals of 1 Hz and maintained at each frequency for about 15 seconds. The frequencies and locations at which resonances occur shall be noted.

2.2.3.3 Endurance Test

The equipment shall be vibrated for a period of at least 90 minutes at each of the resonant frequencies chosen by the test engineer at the corresponding amplitudes shown in Table 2-1. If no resonances are observed, this test shall be performed at the upper frequency as specified in Table 2-1 for each category for a period of two hours.

2.2.3.4 Variable Frequency Test

In addition to the endurance test, the equipment shall be tested in accordance with the vibration levels shown in Table 2-1 or Figure 2-4 at discrete frequency intervals of 1 Hz. At each integral frequency, the vibration shall be maintained for five minutes.

2.2.3.5 Exception

Category 2 or 3 equipment intended for installation solely on a particular class of ship need be vibrated only up through the frequency range that includes the second harmonic exciting frequency of the propeller ($2 \times \text{Maximum Shaft RPM} \times \text{\# of Blades} / 60$).

Table 2-1. Vibration Test Requirements for Shipboard Equipment and Machinery

Category	Frequency Range	Displacement or Acceleration Value*
1. Control and Instrumentation Equipment when mounted on Diesel Engines, Air Compressors and other severe environments.	2 to 25 Hz 25 to 100 Hz	± 1.6 mm (Disp) ± 4.0 g (Accel)
2. Communication and Navigation Equipment, Control and Instrumentation Equipment and other Equipment and Machinery	2 to 15 Hz 15 to 50 Hz	± 1.0 mm (Disp) ± 0.9 g (Accel)
3. Mast-Mounted Equipment	2 to 15 Hz 15 to 50 Hz	± 1.0 mm (Disp) ± 2.25 g (Accel)

*Allowable deviation from these values is 10 percent.

2.2.3.6 Endurance Test for Mast-Mounted Equipment

Equipment intended for installation on masts, such as radar antennae and associated equipment shall be designed for a static load of 2.5 g (1.5 g over gravity) in vertical, athwartship and longitudinal directions to compensate for the influence of rough weather. In addition, the equipment shall be vibrated for a total period of at least 90 minutes at the resonant frequencies chosen by the test engineer. If no resonance is observed, this test shall be performed at 50 Hz, unless excepted by 2.2.3.5 above. The vibration levels shall be in accordance with those of Category 3 in Table 2-1.

2.2.4 Structural Fatigue Failure

Fatigue failures have been known to occur in major ship structures such as the hull girder or bow area in extreme weather conditions. In most cases, however, such failures are the result of design deficiencies in areas of high stress concentration combined with high dynamic or shock loads. As pointed out earlier, this guide does not cover extreme transient forces but instead focuses on periodic forces generated by the operation of the vessel and its machinery under normal operating conditions.

Fatigue failure can occur in the ship's structure under normal operating conditions when the exciting forces are combined with resonant structural vibration, high stress concentration factors, and low system damping. Specific examples of such failures include the hull girder, local structure, and equipment supports.

2.2.4.1 Hull Girder Vibration (Springing)

Hull girder vibration at the fundamental natural frequency of the hull, also referred to as springing, has been found to be a potential problem area for ore carriers on the Great Lakes. This results from a combination of factors that can produce significant dynamic stresses at the hull natural frequency, which when combined with normal loading stresses, can approach dangerous levels.

Unlike oceangoing ships that can experience dangerous hull stress levels by a combination of loading, heavy seas, and slamming effects represented by transient forces, Great Lakes ore

Ship Vibration Design Guide

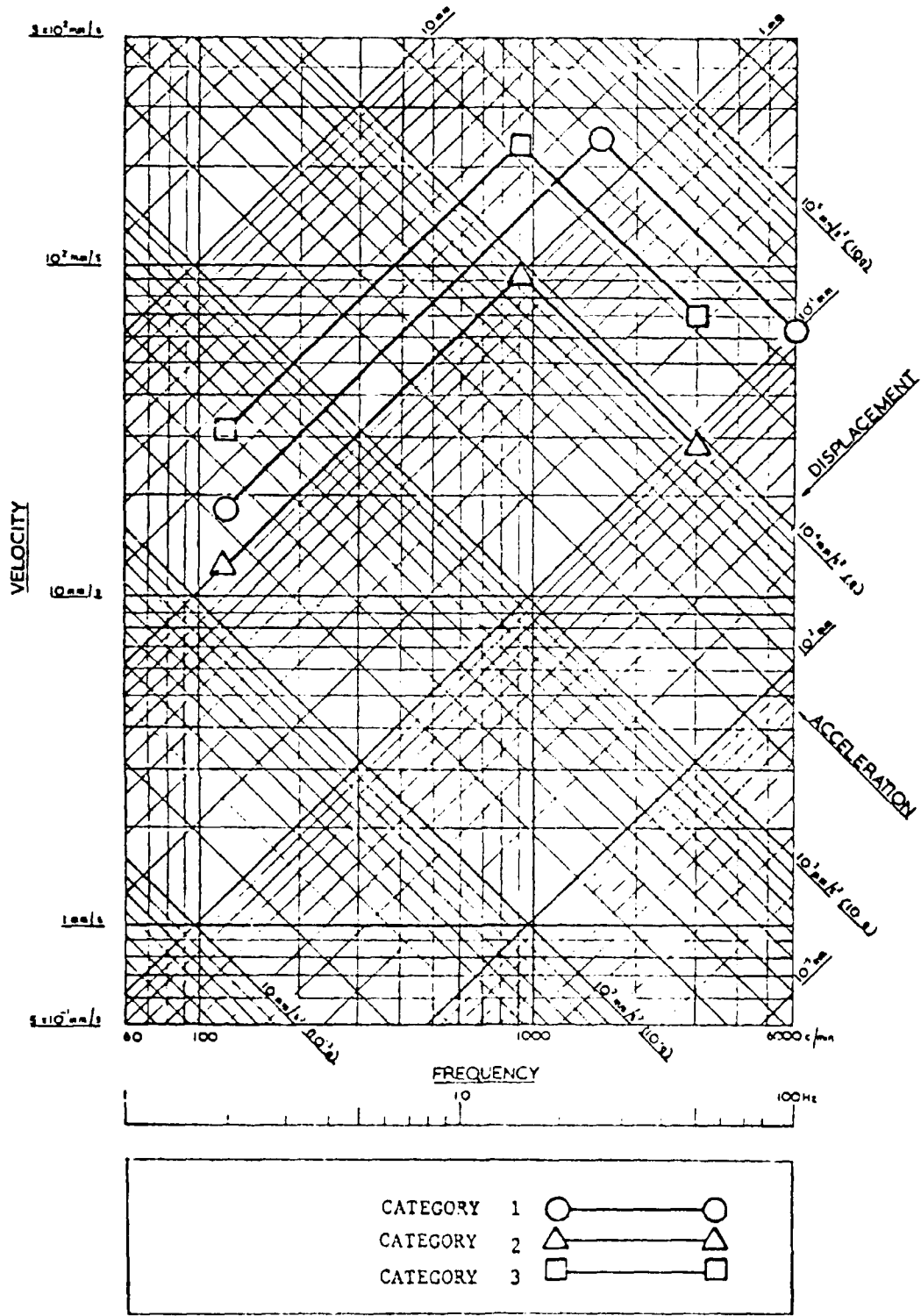

Figure 2-4

Vibration Test Requirements for Various Categories of Shipboard Equipment (Proposed)

carriers are longer more slender, have a relatively lower midship section modulus, and lower natural frequency in bending. In addition, the wave patterns on the Great Lakes are periodic in nature and the periodicity of encounter between the ship and the waves can excite a resonance of the fundamental hull frequency. Supplemental dynamic loading may also be introduced by the nonlinear excitation of two different long wave components interacting. As a result, under certain headings, sea conditions or wave trains, the resulting dynamic hull stresses can be excessive.

Much study has been made on this subject and care must be taken to avoid this resonant phenomena by making necessary adjustments to hull speed and/or direction of encounter with the waves. For purposes of this guide, however, we would recommend adherence to the human reaction or habitability criteria as given in Figure 2-1. Dangerous hull stresses will not occur within an estimated maximum allowable amplitude of ± 25 mm (± 1.00 inch). As an alternative, stress monitoring based on design analyses should be employed.

2.2.4.2 Local Vibration

The majority of structural fatigue failures that occur aboard ship are related to resonant vibration of local structural members, which are readily recognizable. Typical cases include: supports to radar antennas, equipment supports, and handrails. In most cases, the problem is recognizable and may be readily corrected by stiffening the support structure so that resonance does not occur below 115 percent of operating speed.

Not so obvious are fatigue cracks that may develop in the aft peak tank and adjacent structures. Most of such cracks can be related to propeller pressure forces generated by cavitation effects and resonant local structural elements with high stress concentration factors. The immediate correction usually involves stiffening of the resonant member and the elimination of stress concentration points. Depending on other problems aboard the ship, consideration might be given to the correction of the exciting forces. If this approach is taken, a maximum hull pressure force of ± 8 kPa or ± 1.16 psi, measured on the centerline over the propeller is recommended.

2.3 Machinery Vibration

Shipboard machinery includes the main propulsion machinery, auxiliary machinery, support machinery, and related equipment. In this category, primary concern is with the effects of vibration on system dynamics (fatigue failure of components) and the environmental effects on machines and equipment (damage and/or malfunction). Active shipboard equipment introduces self-generating forces. Subsections of this chapter include Main Propulsion Machinery, which relates to fatigue failure of components, and General Machine Vibration, which relates to environmental effects.

2.3.1 Main Propulsion Machinery

Main propulsion machinery includes all components from the engine up to and including the propeller. Vibration of the ship and dynamic stresses within the propulsion system result from forces generated both by the propeller and by the propulsion system components.

Ship Vibration Design Guide

Recommended criteria to be employed in the control of the more important dynamic forces existing in the main propulsion system are based on design requirements.

It should be noted that vibration measurements alone cannot always be used to determine the acceptability of dynamic systems. The levels of dynamic stresses are dependent on both the vibration amplitude and the dynamic analysis of the vibrating system.

Main engines, shafts, couplings, reduction gears, propellers, and related equipment are designed for structural adequacy when operating under the conditions stipulated in the procurement specifications. The vibration characteristics of the propulsion system must be controlled to avoid the presence of damaging vibratory stresses within the system, as well as the generation of severe hull vibration. Potential problem areas include unbalance and misalignment of system components; excessive shaft stresses; and longitudinal, torsional, and lateral vibration of the propulsion system.

2.3.1.1 Dynamic Unbalance and Misalignment

All rotating propulsion machinery should be balanced to minimize vibration, bearing wear, and noise. The types of correction, as shown in Table 2-2 below, should depend on the speed of rotation and relative dimensions of the rotor.

Table 2-2. Types of Correction

Type of Correction	Speed (RPM)	Rotor Characteristics
Single-Plane	0 - 1000	L/D ≤ 0.5
	0 - 150	L/D > 0.5
Two-Plane	> 1000	L/D ≤ 0.5
	> 150	L/D > 0.5
Multi-Plane		Flexible: Unable to correct by two-plane balancing

L = Length of rotor mass, exclusive of shaft
D = Diameter of rotor mass, exclusive of shaft

The residual unbalance in each plane of correction of any rotating part shall not exceed the value determined by:

$$U = \frac{4W}{N} \quad \text{for speeds in excess of 1000 RPM}$$

$$U = \frac{4000W}{N^2} \quad \text{for speeds between 150 and 1000 RPM}$$

$$U = 0.177W \quad \text{for speeds below 150 RPM}$$

where:

U = Maximum residual unbalance in ounce-inches

W = Weight of rotating part in pounds

N = Maximum operating RPM of unit

When checking the propulsion system for first-order (shaft RPM frequency) forces, in addition to balancing, the following should be considered: propeller for pitch accuracy; shafting and couplings for run-out or bending; and stern bearings for uneven or excessive wear. Shafting should also be checked for corrosion/fatigue cracks originating in keyway fillets.

2.3.1.2 Dynamic Shaft Stresses

Conventional design requirements for propulsion shafting generally include factors to compensate for the eccentric thrust produced at the propeller. This eccentric thrust produces a dynamic bending moment due to shaft rotation with maximum alternating bending stresses usually occurring at the propeller keyway. Dynamic stress is greatly influenced by the actual moment arm between the propeller and the effective point of support of the aftermost bearing. Additionally, the presence of seawater presents a corrosive medium and greatly deteriorates the fatigue characteristics of the shaft. These stresses are also significantly effected by sea and operating conditions and are the root cause of most shaft failures.

If during normal maintenance procedures, evidence of fatigue cracks in the tailshaft in the vicinity of the forward face of the propeller are noted, it would be prudent to check the alternating bending stress of the tailshaft against the following empirical formula:

$$S = C \frac{(M_g + M_t)}{6000}$$

where:

$$S = \text{Section modulus} = \frac{I}{R}$$

$$C = \text{Service factor} = 1.75 \text{ for commercial ships}$$

$$M_g = \text{Gravity moment due to overhanging propeller weight calculated from forward face of propeller hub to assumed point of shaft support (1 diameter of shaft for water lubricated bearing and } \frac{1}{2} \text{ diameter for oil lubricated)}$$

$$M_t = \text{Calculated moment of eccentric thrust} = 0.65 \times \text{Propeller Diameter} \times \text{Rated Thrust}$$

$$I = \text{Shaft moment of inertia}$$

$$R = \text{Shaft radius}$$

$$6000 = \text{Maximum safe fatigue limit (psi) to be used for the assembly operating in the presence of a corrosive medium}$$

Cold rolling the tailshaft in the vicinity of the keyway forward beyond the aft end of the liner has been found to be effective in retarding the propagation of fatigue cracks. A detailed

dynamic analysis of the complete propulsion system is strongly recommended, particularly in the case of diesel drive systems or new or unusual design concepts.

2.3.1.3 Torsional Vibration

The mass-elastic system, consisting of engine, couplings, reduction gears, shafting, and propeller, should have no excessive torsional vibratory stresses below the top operating speed of the system nor excessive vibratory torque across the gears within the operating speed. Excessive torsional vibratory stress is that stress in excess of:

$$S_v = \frac{\text{Ultimate Tensile Strength}}{25}$$

Below the normal operating speed range, excessive torsional vibratory stress is that stress in excess of 1 3/4 times S_v .

Excessive vibratory torque, at any operating speed, is that vibratory torque greater than 75 percent of the driving torque at the same speed, or 10 percent of the full load torque, whichever is smaller.

Gear rattling is a strong indication of torsional vibration in a geared drive. To evaluate any torsional vibration measurements, it is necessary to have available, or to develop, a complete mathematical analysis of the system to be tested. It is obvious that experienced personnel are required to conduct such studies.

2.3.1.4 Longitudinal Vibration

Longitudinal vibration of the main propulsion system is frequently a problem and can cause significant structural vibration within the ship. It may be very pronounced at the main thrust bearing, at other parts of the propulsion system, and particularly in the higher levels of deckhouses. If significant vibration in the fore-and-aft direction is noticed, the problem should be investigated.

To avoid damage or crew annoyance, the propulsion system should have no excessive alternating thrust within the operating speed range. In no case, however, should the displacement amplitude of longitudinal vibration of the propulsion machinery, including the main condenser and associated piping in a steam turbine drive, be sufficient to adversely affect the operation of the propulsion unit or precipitate fatigue failure of components such as thrust bearings or gear teeth. Pitting of gear teeth may also indicate excessive torsional or longitudinal vibration.

Excessive alternating thrust is defined as:

(a) Main and turbine thrust bearings

Excessive alternating thrust occurs when the single amplitude of alternating thrust, measured at the main and turbine thrust bearings, exceeds 75 percent of the mean thrust at that speed or exceeds 25 percent of the full power thrust, whichever is smaller.

(b) Excessive alternating thrust

Excessive alternating thrust in the reduction gear occurs when the vibratory acceleration of the bull gear hub exceeds ± 0.1 g, unless another value is provided by the gear manufacturer. If the acceleration exceeds the allowable value, calculations will be required to determine the vibratory stresses in the gear teeth to determine their acceptability to the gear supplier.

(c) Excessive longitudinal vibration

Excessive longitudinal vibration of the main propulsion system components (including condenser, piping, etc.) occurs when vibration exceeds ± 0.25 g, or that level certified as satisfactory by the equipment manufacturer, whichever is the least.

Although detailed measurements would be required to evaluate the presence of excessive longitudinal vibration in (a) or (b) above, hammering of the thrust bearing represents a very dangerous condition and must be avoided. As in the case of excessive torsional vibration, gear rattling may also occur if the longitudinal vibration is excessive. In some instances, particularly in diesel drives, harmonic components of torsional and longitudinal vibration may be coupled through the action of the propeller.

2.3.1.5 Lateral Vibration

Lateral vibration in the main propulsion shafting could be destructive if the fundamental frequency is resonant in the operating speed range. This phenomena, sometimes referred to as "whirling," occurs at shaft RPM and is excited by propeller and shafting unbalance. In all designs, the fundamental frequency must occur well above operating speed (115 percent of maximum RPM). Frequency can be effected, however, by misalignment, bearing wear down, or lost bearing support (structural failure).

Whirling frequencies at blade rate frequency are excited by propeller forces at \pm the shaft rate. Thus, a five-bladed propeller would excite fourth and sixth order frequencies, referred to as counter whirl and forward whirl, respectively. However, these frequencies are not generally significant because of the low level of propeller forces normally encountered. It is usually customary to avoid the presence of the frequencies in the upper 15 percent of the speed range.

2.3.2 General Machinery Vibration

Shipboard machinery is referred to in this guide as "active" shipboard equipment since, in addition to being affected by general hull vibration, it generates vibratory forces that contribute to the total motion of the machine itself and may also adversely effect the structure to which it is attached. The maximum acceptable vibration of shipboard machinery is frequently defined by the manufacturer. When this information is available it should be used. When such information is not available the criteria provided herein is recommended.

2.3.2.1 Nonreciprocating Machines

The maximum allowable vibration of rotating machinery required to demonstrate compliance with MIL-STD-167-1 (SHIPS) balancing requirements is shown in Figure 2-5. On all machinery except turbines, amplitudes of vibration are measured on the bearing housing in the

Ship Vibration Design Guide

direction of maximum amplitudes. In the case of turbines, amplitudes of vibration are measured on the rotating shaft adjacent to the bearings. When feasible, machinery is completely assembled and mounted elastically at a natural frequency less than one-quarter of the minimum rotational frequency of the unit. Large and complex units are shop tested on a foundation similar to the shipboard mounting for which it is intended. These requirements are recommended for new, replacement, or reworked equipment.

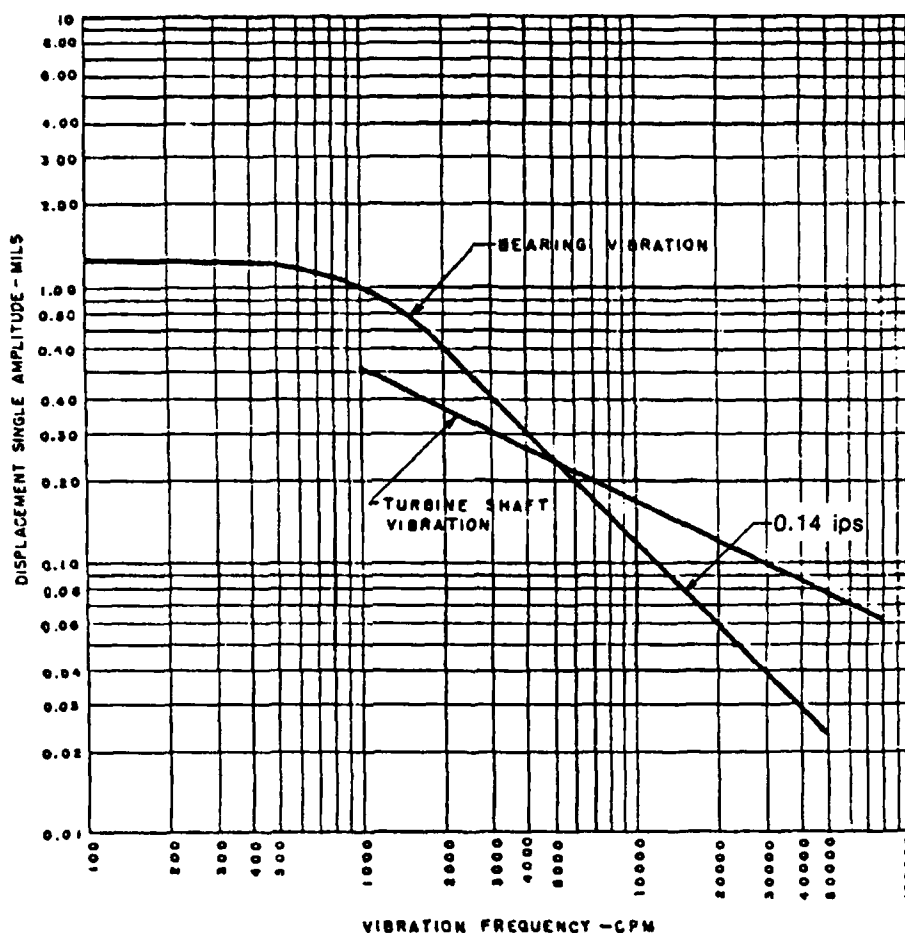

Figure 2-5

Maximum Allowable Vibration, Type II (MIL-STD-167-1 (SHIPS), 1 May 1974)

The SNAME T&R Code C-5, "Acceptable Vibration of Marine Steam and Heavy-Duty Gas Turbine Main and Auxiliary Machinery Plants," provides maximum allowable vibration levels for shop test and shipboard test as illustrated in following figures:

Figure 2-6 For steam turbine bearing housing or gear casing measurements

Figure 2-7 For gas turbine housing measurements

Figure 2-8 For steam turbine shaft measurements

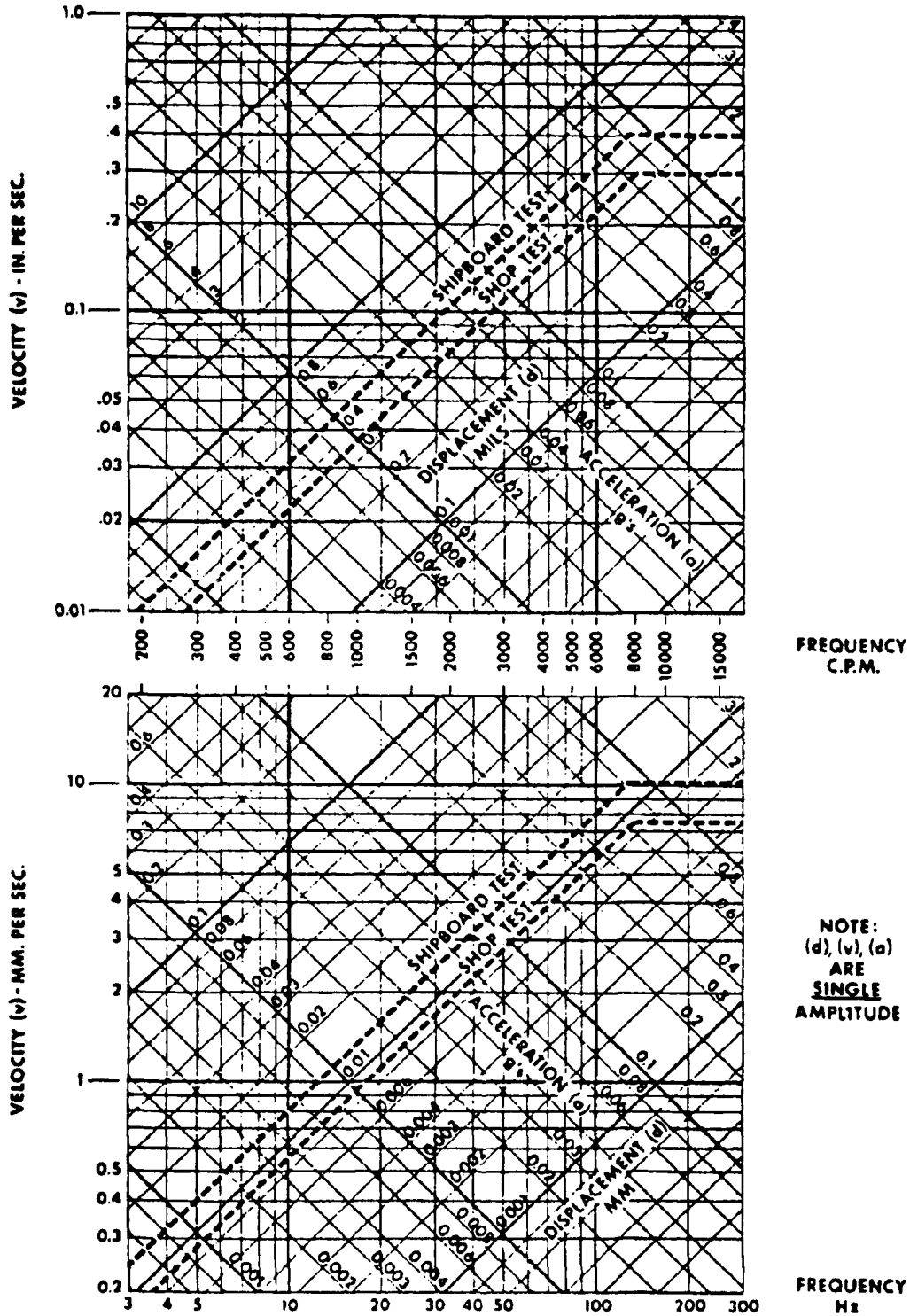

Figure 2-6

Main Propulsion Steam Turbines and Reduction Gears - Turbine Bearing Housing and Gear Casing Vibration Limits

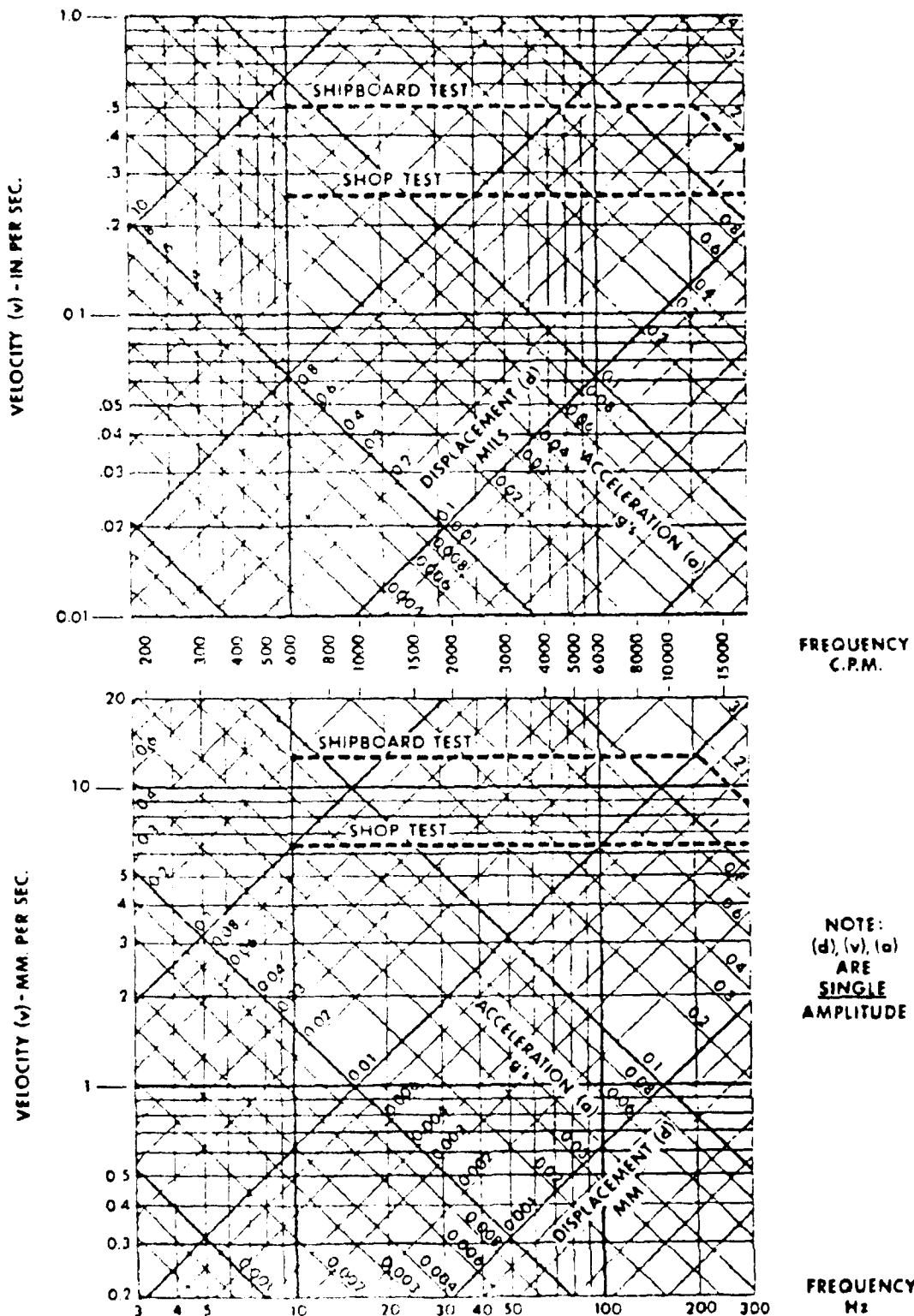

Figure 2-7

Main Propulsion Gas Turbines Bearing Housing Vibration Limits

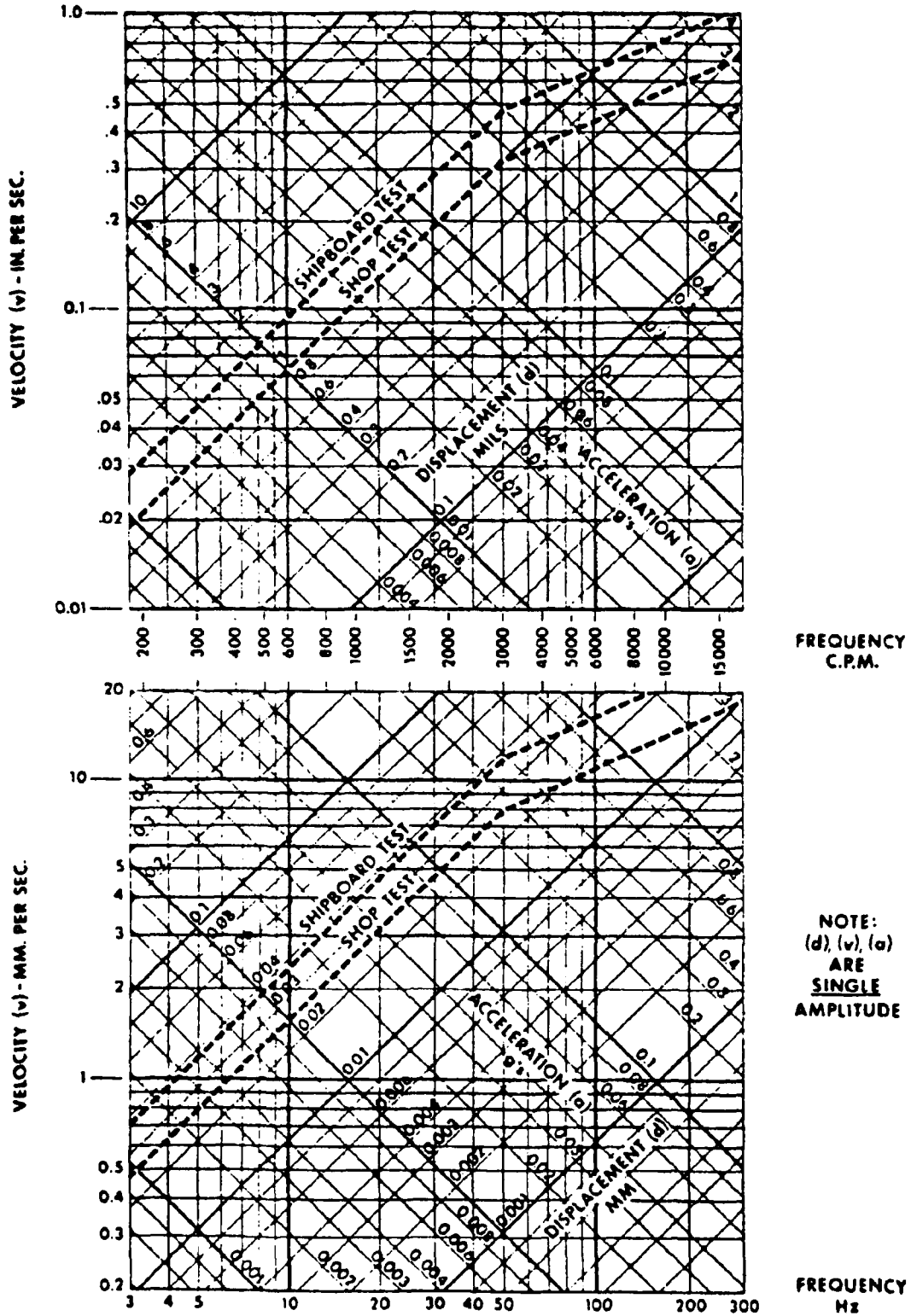

Figure 2-8
Main Propulsion Units - Shaft Vibration Limits

Ship Vibration Design Guide

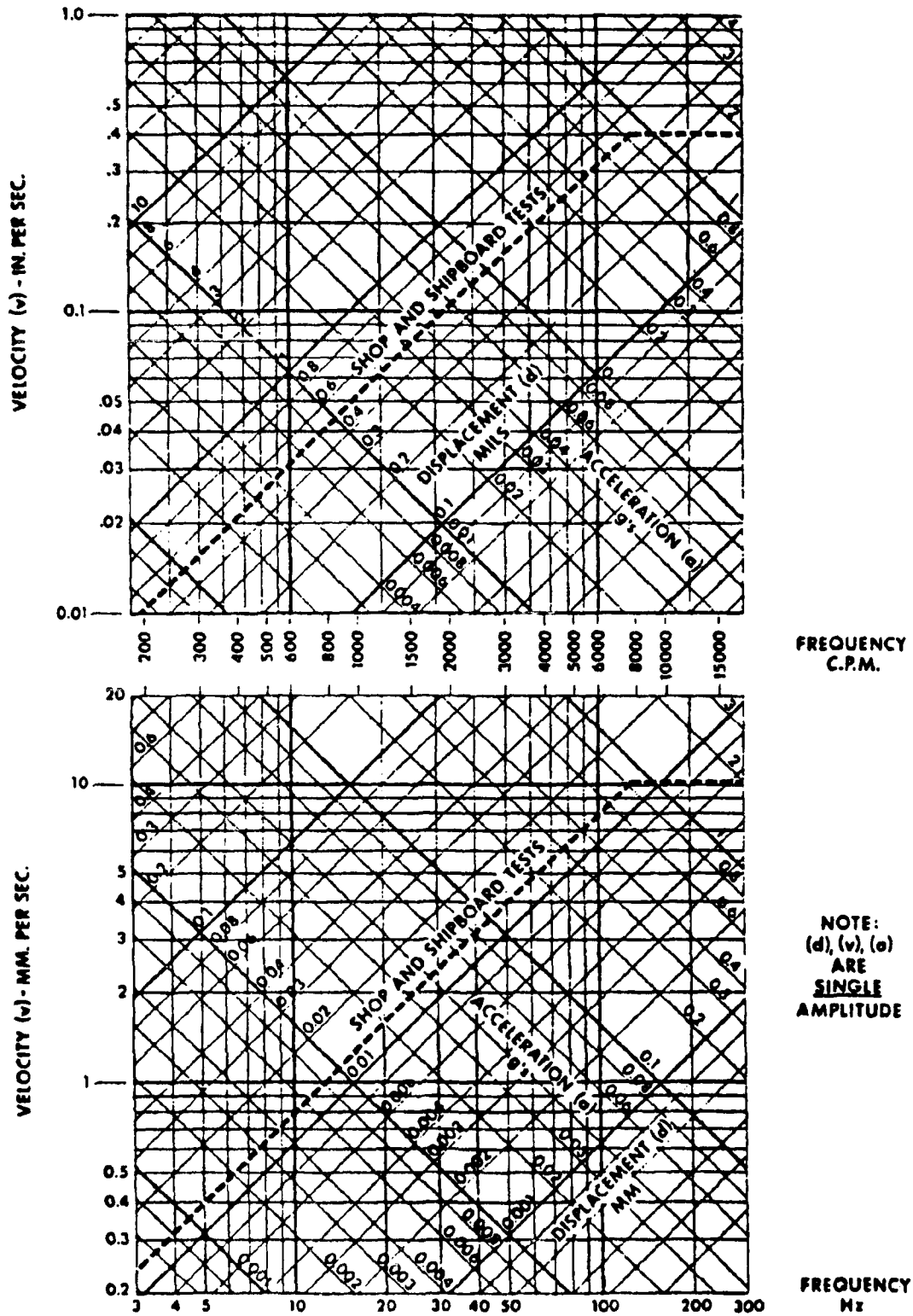

Figure 2-9

Turbine Driven Auxiliaries - Bearing Housing Vibration Limits

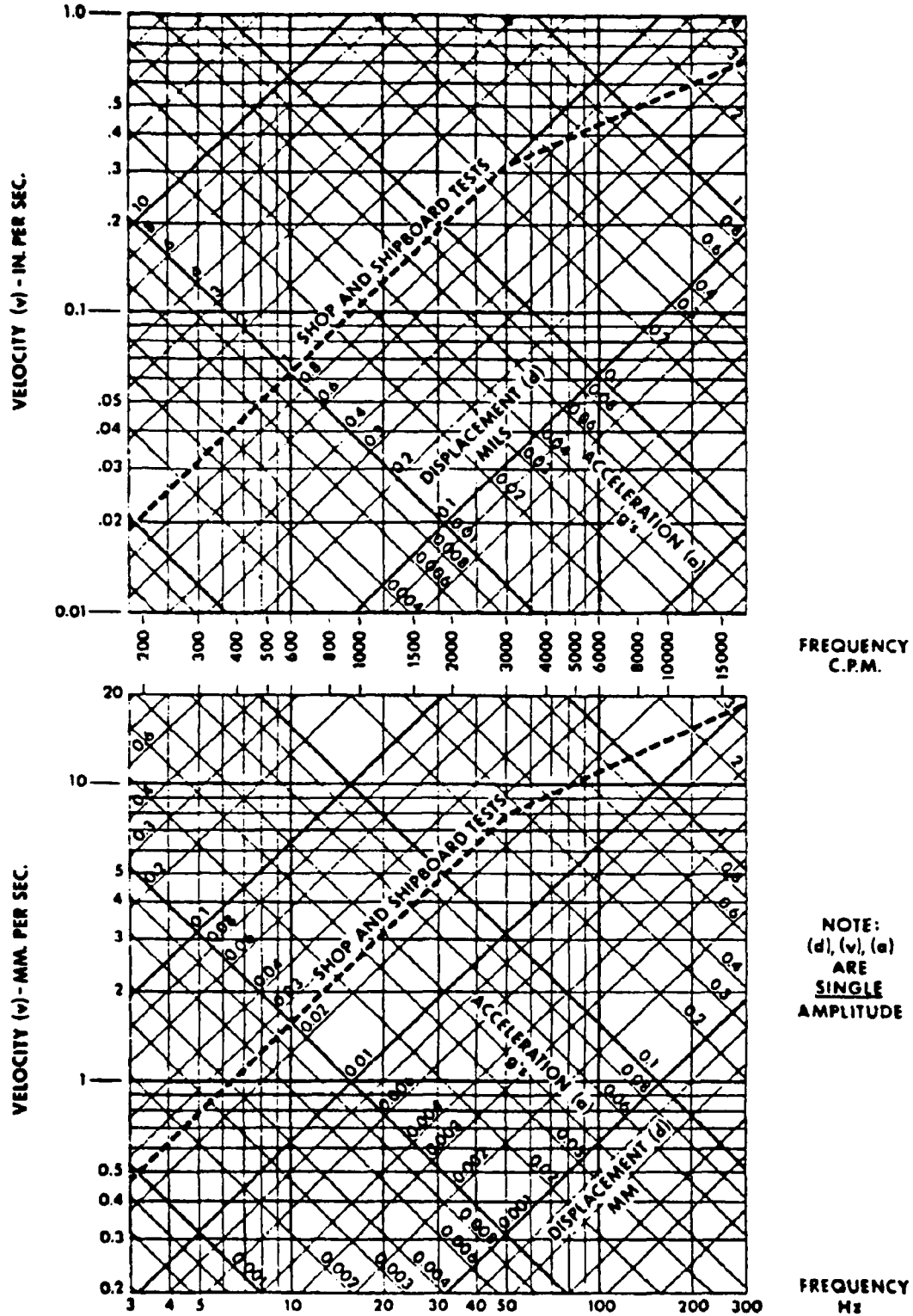

Figure 2-10

Turbine Driven Auxiliaries - Shaft Vibration Limits

Ship Vibration Design Guide

These limits are narrowband readings of first order (rotational frequency) and second order vibration and apply to steady state operation, preferably under trial conditions called for under SNAME Code C-1 or ISO 4867. Measurements that exceed the limits called for by "Shipboard Test" indicate corrective action required.

Similarly, Figures 2-9 and 2-10 give the maximum acceptable levels applicable to turbine driven auxiliaries for measurements made on the bearing housing or shaft, respectively.

For motor-driven auxiliaries, the maximum first order and second order bearing housing vibration velocities of the assembled driver and driven equipment is recommended to be ± 0.25 inches per second above 30 Hz and ± 2.5 mils below 30 Hz. For new or replacement equipment, the values shown by MIL-STD-167, Figure 2-5 should be used.

2.3.2.2 Reciprocating Engines

Based on data presented by Bureau Veritas Guidance Note NI 1381-RD3, "Recommendations Designed to Limit the Effects of Vibration Onboard Ships," June 1979 [2-8], the acceptable vibration levels for diesel engines and reciprocating engines are as shown on Figure 2-11. Vibratory levels at ± 11 mm/sec measured at the base of the engines should be monitored, while ± 18 mm/sec for the smaller engines (1000 HP) and ± 28 mm/sec for larger engines (1000 HP) would be considered excessive. Somewhat higher levels could be tolerated at the cylinder heads.

2.4 Ship Vibration Specifications

It has been shown that hull vibration criteria is primarily based on habitability requirements. It was also shown in a recent paper [2-5] that upwards of 60,000 SHP on a single screw ship would be possible, within habitability criteria. It is therefore reasonable to expect that lower levels of hull vibration could be realized on ships with lower power requirements if the owner was willing to spend the effort in achieving that objective. On a recent tanker design of 15,000 SHP, the owner specified vibration limits of 4 mm/sec, corresponding to the lower line of the shaded area of Figure 2-1. That objective was successfully met.

In line with the above information, a suggested set of ship vibration specifications is presented for guidance purposes. In this instance, requirements are established that are considered practical but with an incentive in the form of a design objective and a reject hull vibration level. This approach is proposed as a means of establishing a joint working basis between the owner and builder, as opposed to the frequent adversarial relationship.

The specification sample is based on the development of a large single-screw tanker with a geared-turbine drive and a rating of 30,000 SHP. The habitability requirements are based on the current ISO Guidelines [2-2], when tested in accordance with the ISO Vibration Test Codes, [2-6] and [2-7]. With a geared-turbine drive, the constant velocity limit is extended below 5 Hz to 1 Hz, rather than using the constant acceleration limit, between 5 Hz and 1 Hz, which is considered appropriate for low speed direct diesel drives.

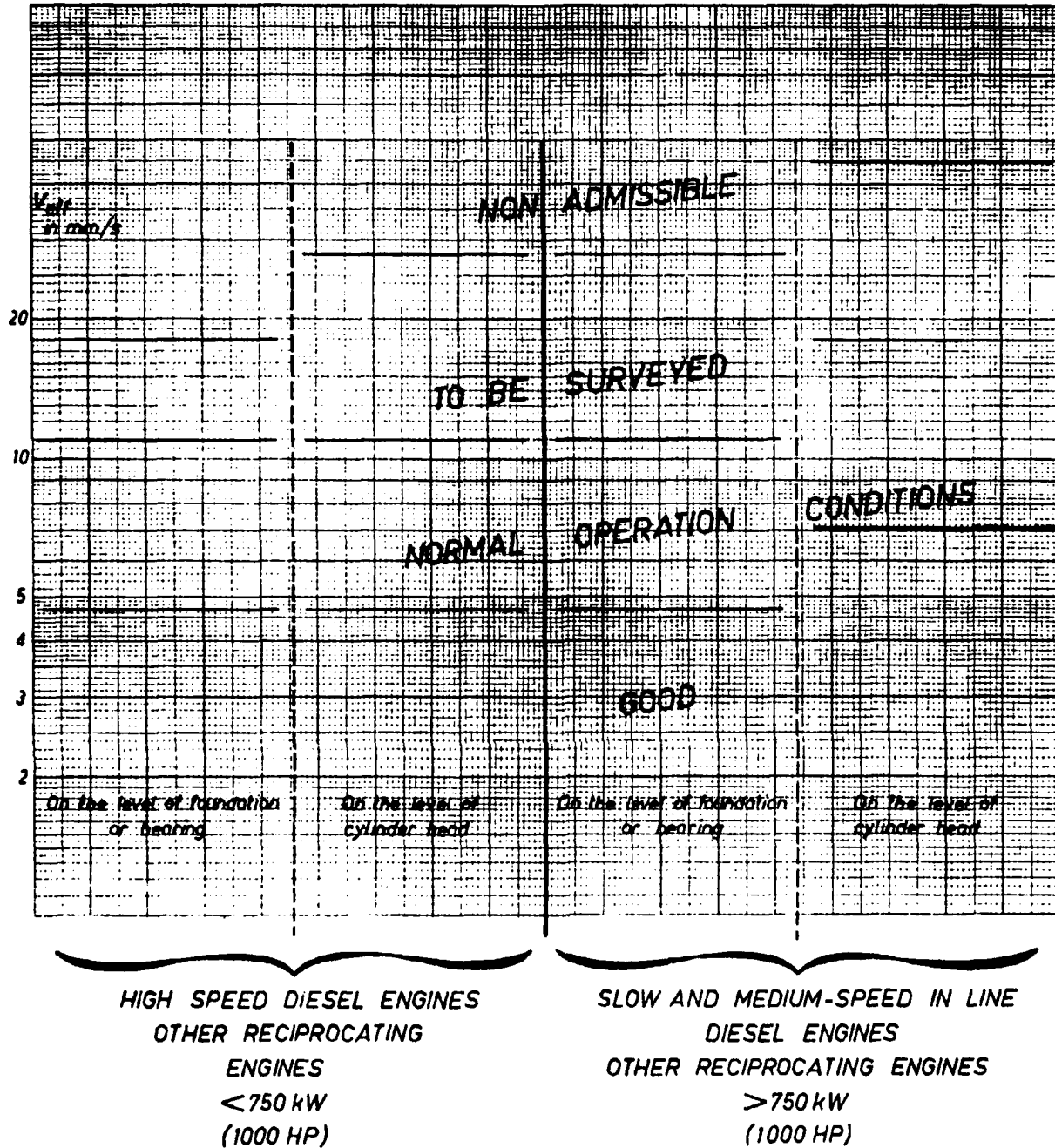

- For slow-speed engines up to 150 RPM, the equivalent velocity amplitude should be less than 0.5 mm when measured at bearings and foundations
- For piping mounts and miscellaneous units, acceleration should be less than 1.5 g

Figure 2-11

Vibratory Levels of Diesel Engines and Reciprocating Engines

SAMPLE SHIP SPECIFICATIONS:

Vibration

A. General Requirements

The vessel shall be designed and constructed to limit the vibration of the ship and within the ship to those generally accepted levels that will not result in discomfort or annoyance to the crew, will not prove damaging to the main propulsion system, or will not precipitate damage or malfunction of other shipboard machinery and equipment when operating up to maximum (ABS) horsepower. It shall be the responsibility of the shipyard to provide a design that will meet the vibration criteria set forth in this specification. Tests will be conducted during the trials of the vessel to establish compliance with this criteria. Necessary corrections will be the responsibility of the shipbuilder.

During the design phase, the shipbuilder shall prepare an analysis of the response of the main hull girder with respect to the generation of the driving forces originating in the main propulsion system. This analysis will provide the base from which the response of the major substructures, local structures, and supporting systems for equipment may be evaluated.

The selection of the propeller type, number of blades, skew and clearances should be compatible with the desired vibration characteristics of the main hull girder and propulsion machinery.

B. Hull Girder Criteria

The design objective is to limit the vibration of the main hull girder to a velocity of ± 6 mm/s, between 1 and 100 Hz, in all three directions (vertically, athwartship and longitudinally) when tested in accordance with the International Standard (ISO 4867), "Code for the Measurement and Reporting of Shipboard Vibration Data." Amplitudes greater than 150 percent of this value will be considered unacceptable for geared turbine or geared diesel drive systems. For low-speed, direct-drive diesels, accelerations greater than $\pm .029$ g below 5 Hz will be considered unacceptable.

C. Criteria for Major Substructures

The criteria for the vibration of major substructures occupied by the crew is based on habitability requirements. The design objective is a maximum velocity of ± 7.5 mm/s in all three directions when tested in accordance with ISO 4867. Amplitudes greater than ± 9 mm/s will be considered unacceptable. The criteria for the vibration of major substructures, not inhabited by the crew, is ± 9 mm/s, provided this level of vibration is acceptable to equipment mounted thereon, as defined by the equipment manufacturer. Below 5 Hz, the acceleration limit of $\pm .029$ g is applicable for direct-drive, low-speed diesel ships.

D. Criteria for Local Structural Elements

The criteria for local structural elements, if they are considered as part of a habitable space in contact with the crew, such as a compartment floor or bulkhead, should be based on habitability requirements. Amplitudes greater than ± 9 mm/s in any direction shall be considered unacceptable.

Vibration Criteria and Specifications

The criteria for the vibration of structural elements not in contact with the crew and not supporting equipment is $\pm 0.25g$, providing no structural damage results or that noise generated by the vibration is not considered excessive (greater than 70 dBA). If damage to structural elements, or if excessive noise in habitable compartments results, corrective action by the shipyard will be required.

The criteria for the vibration of structural elements supporting vibration-sensitive equipment must be limited to that level considered acceptable to the equipment, as specified by the equipment manufacturer or $\pm 0.25g$, whichever is the least.

E. Criteria for Shipboard Equipment

Equipment selected should be designed to meet the environmental vibration requirements established for shipboard use. In this instance, $\pm 0.25g$ should be used. Balancing and vibration tolerances for rotating machines should be representative of and must meet the acceptable standards for good commercial practice. Installation details, including the choice of mountings, should be designed to prevent excessive vibration of equipment or the generation of excessive vibration or noise in the compartment (or adjacent habitable spaces) in which it is installed. Excessive vibration is that above $\pm 0.25g$, or that level for which the equipment is certified by the manufacturer, whichever is the least. The vibration generated noise is excessive when it is over 70 dBA.

F. Vibration of Main Propulsion Machinery

The main engines, shafts, couplings, reduction gears, propellers and related equipment should be designed for structural adequacy when operating under the conditions stipulated in the procurement specifications. Vibration characteristics of the propulsion system must be controlled to avoid the presence of damaging vibratory stresses within the system, as well as the generation of severe hull vibration. Potential problem areas include: unbalance and misalignment of system components; excessive shaft stresses; and longitudinal, torsional and lateral vibration of the propulsion system.

F.1 Balancing Requirements for Propulsion Machinery

All rotating propulsion machinery shall be balanced to minimize vibration, bearing wear, and noise. The type of correction, as shown in the following table, shall depend on the speed of rotation and the relative dimensions of the rotor.

Table F-1 Balancing Procedure Criteria

Type of Correction	Speed (RPM)	Rotor Characteristics
Single-Plane	0 - 1000	$L/D < 0.5$
	0 - 150	$L/D > 0.5$
Two-Plane	> 1000	$L/D \leq 0.5$
	> 150	$L/D > 0.5$
Multi-Plane		Flexible: Unable to correct by two-plane balancing

L = Length of rotor mass, exclusive of shaft
D = Diameter of rotor mass, exclusive of shaft

Ship Vibration Design Guide

The residual unbalance in each plane of correction of any rotating part shall not exceed the value determined by:

$$U = \frac{4W}{N} \quad \text{for speeds in excess of 1000 RPM}$$

$$U = \frac{4000W}{N^2} \quad \text{for speeds between 150 and 1000 RPM}$$

$$U = 0.177W \quad \text{for speeds below 150 RPM}$$

where:

U = Maximum residual unbalance in ounce-inches

W = Weight of rotating part in pounds

N = Maximum operating RPM of unit

F.2 Design of Tailshaft

To avoid the possibility of a corrosion fatigue failure of the propeller shaft, in addition to meeting the ABS design requirements, the alternating bending stresses in the tail shaft shall be limited to $\pm 6,000$ psi when calculated by the following expression (English units used):

$$S = C \frac{(M_g + M_t)}{6000}$$

where:

$$S = \text{Section modulus} = \frac{I}{R}$$

C = Service factor = 1.75 for commercial ships

M_g = Gravity moment due to overhanging propeller weight calculated from forward face of propeller hub to assumed point of shaft support (1 diameter of shaft for water lubricated bearing and $\frac{1}{2}$ diameter for oil lubricated)

M_t = Calculated moment of eccentric thrust = 0.65 x Propeller Diameter x Rated Thrust

I = Shaft moment of inertia

R = Shaft radius

6000 = Maximum safe fatigue limit (psi) to be used for the assembly operating in the presence of a corrosive medium

F.3 Longitudinal Vibration of Propulsion Machinery

The dynamic response of the propulsion system shall have no excessive alternating thrust within the operating speed range. In no case, however, shall the displacement amplitude of longitudinal vibration of the propulsion machinery, including the main condenser and associated piping, be sufficient to adversely affect the operation of the propulsion unit or precipitate fatigue failure.

Excessive alternating thrust is defined as:

(a) Main and turbine thrust bearings

Excessive alternating thrust occurs when the single amplitude of alternating thrust, measured at the main and turbine thrust bearings, exceeds 75 percent of the mean thrust at that speed or exceeds 25 percent of the full power thrust, whichever is smaller.

(b) Excessive alternating thrust

Excessive alternating thrust in the reduction gear occurs when the vibratory acceleration of the bull gear hub exceeds $\pm 0.1g$ unless another value is provided by the gear manufacturer. If the acceleration exceeds the allowable value, calculations will be required to determine the vibratory stresses in the gear teeth to determine acceptability to the gear supplier.

(c) Excessive longitudinal vibration

Excessive longitudinal vibration of the main propulsion system components (including condenser, piping, etc.) occurs when the vibration exceeds $\pm 0.25g$, or that level certified as satisfactory by the equipment manufacturer, whichever is the least.

A mathematical analysis of the longitudinal vibratory characteristics of the mass-elastic system shall be prepared by the engine builder or the shipyard to demonstrate the probable compliance with the given criteria. This analysis is to be forwarded to the owner for review. During ship trials, measurements shall be performed to demonstrate compliance with specified limits in accordance with the International Standard, ISO 4867, "Code for the Measurement and Reporting of Shipboard Vibration Data."

F.4 Torsional Vibration of Propulsion System

The mass-elastic system, consisting of engine, couplings, reduction gears, shafting, and propeller, should have no excessive torsional vibratory stresses below the top operating speed of the system nor excessive vibratory torque across the gears within the operating speed. Excessive torsional vibratory stress is that stress in excess of

$$S_v = \frac{\textit{Ultimate Tensile Strength}}{25}$$

Ship Vibration Design Guide

Below the normal operating speed range, excessive torsional vibratory stress is that stress in excess of $1 \frac{3}{4}$ times S_v .

Excessive vibratory torque, at any operating speed, is that vibratory torque greater than 75 percent of the driving torque at the same speed, or 10 percent of the full load torque, whichever is smaller.

A mathematical analysis of the propulsion system shall be prepared by the engine builder or shipyard to demonstrate probable compliance with these requirements. This analysis is to be forwarded to the owner for review. In the event the analysis does not indicate probable compliance, a torsigraph test will be required, prior to acceptance.

F.5 Lateral Vibration of Propulsion Shafting

No critical frequency of lateral vibration of the propulsion shafting system shall exist below 115 percent of maximum rated shaft RPM. A mathematical analysis of the lateral vibration characteristics of the rotating propulsion shafting system shall be made to clearly demonstrate that the system is free from any lateral critical frequency below 115 percent of the maximum rated RPM. This analysis shall be submitted to the owner for review.

REFERENCES

- 2-1 Noonan, E. F., "An Approach to the Limitation and Control of Shipboard Vibration," 51st Shock and Vibration Symposium, San Diego, CA, Sept. 1980.
- 2-2 International Standard, ISO 6954, "Mechanical Vibration and Shock - Guidelines for the Overall Evaluation of Vibration in Merchant Ships," Dec. 1984.
- 2-3 "Ship Vibration and Noise Guidelines," SNAME T & R Bulletin 2-25, January, 1980.
- 2-4 International Standard, ISO 2631, "Guide for the Evaluation of Human Exposure to Whole Body Vibration" - Part I, General Requirements
- 2-5 Chang, Noonan, Scherer, Seibold and Weschsler, "Limitations on the Maximum Power of Single-Screw Ships," SNAME Transactions, Vol. 87, 1979.
- 2-6 International Standard, ISO 4867, "Code for the Measurement and Reporting of Shipboard Vibration Data," Dec., 1984.
- 2-7 International Standard, ISO 4868, "Code for the Measurement and Reporting of Local Vibration Data of Ship Structures and Equipment," Nov., 1984.
- 2-8 "Recommendations Designed to Limit the Effects of Vibrations on Board Ships," Bureau Veritas Guidance Note NI 138A-RD3, June, 1979.
- 2-9 "Code for Shipboard Vibration Measurement," SNAME T & R Code C-1, 1975.

EXCITATION OF VIBRATORY FORCES

In this chapter, practical guidelines are presented for developing the hull form, appendage and propeller designs of a new ship, such that the excitation of vibratory forces will be minimized. The emphasis is on minimization of vibratory forces of hydrodynamic origin, minimization of vibratory forces due to the imbalance of propellers, propeller blade pitch differences, imbalance or misalignment of shafting, and imbalance of propulsion engines is also briefly considered. Only currently available information and methods are presented, and the focus is on the early stages of the design of single- and twin-screw ships. In addition to presenting methods for designing to minimize vibratory forces, early design stage methods for estimating such forces for a proposed ship are also presented.

With respect to the vibratory forces of hydrodynamic origin, the principal parameters involved are those which describe the hull (especially the afterbody), the afterbody appendages and the propeller(s). The basic relationship between the hull, appendages and propeller(s) is that, at the required speed, a certain amount of thrust is required to overcome the resistance of the hull and appendages and the propeller(s) must provide this thrust at a given number of revolutions. The ship resistance characteristics and the propeller dimensions, primarily, determine the propeller thrust loading; the thrusting propeller alters the flow along the hull forward of and near the propeller, which in turn affects the wake field. The non-homogeneity of this wake field causes the propeller blade loading to fluctuate with time and this causes a corresponding fluctuation in the forces applied to the ship; these forces are normally considered to be applied to the ship as fluctuating vertical and horizontal forces at the stern bearing(s), fluctuating axial forces at the thrust bearing(s), fluctuating torque at the reduction gear(s) or engine(s), and fluctuating pressure forces on the hull in the immediate vicinity of the propeller(s). The fluctuations in propeller blade loading that occur also cause changes in blade cavitation patterns when cavitation is present; this effect can cause a considerable augmentation of the hull pressure forces. From the perspective of hull form and appendage design, it is to be noted that by careful selection of hull form type and by careful development of hull form shape (particularly afterbody shape), it may be possible to minimize wake field variations; this, together with careful selection of the propeller characteristics, will have the effect of minimizing the magnitude of the fluctuating forces, which are applied to the hull and propeller.

3.1 Guidelines for Minimization of Propeller-Induced Vibratory Forces

3.1.1 Approach

The recommended approach to the design of the hull form, afterbody appendages and propeller(s), for the purpose of minimizing propeller-induced vibratory forces, is to give primary attention to selection of the basic propeller characteristics (diameter, number of blades and blade area ratio) such that thrust loading can be kept to moderate levels. This includes giving consideration even to selection of the number of propellers to be installed; in general, the use of twin-screw propulsion, when it is reasonable to do so, will reduce the potential for excessive vibratory force due to the increased blade area, which may be achievable and due to the more uniform inflow to the propellers, compared with a single-screw installation. Achieving moderate levels of thrust loading will tend toward minimization of cavitation, thereby minimizing cavitation augmentation of hull pressure forces. By proper selection of the number of blades, hull and propulsion system resonant response can normally be avoided. Then, by appropriate selection of the basic afterbody type and propulsion appendage configuration, and by development of the details of the afterbody form and of the shape and arrangement of the afterbody appendages, wake (propeller inflow) non-uniformity can be minimized. By taking this approach and by careful design of the propeller blades, the fluctuations in hull pressure, in propeller thrust and torque delivered to the shaft(s), and in the propeller shaft bearing forces, can be minimized. The selection and design development of the afterbody, appendages and propeller(s) is an iterative process and the designs of these three major elements are, of course, interrelated. A flowchart, which illustrates this process with particular reference to closed-stern, single-screw ships, has been presented by Ward [3-1] and is included herein as Figure 3-1. The process will be briefly reviewed in the sections that follow. Although the designs of the three above mentioned elements may be carried out simultaneously, afterbody selection and design are described first. This is followed by descriptions of the selection and design of the afterbody appendages and the propeller(s), in that order.

3.1.2 Selection of Afterbody Type

Of course the overall characteristics of the hull must be selected before attention can be given to the afterbody. The length (L), beam (B), draft (T), amidships depth (D), basic proportions (L/B , B/T , L/T and B/D), midship section coefficient (C_M), longitudinal prismatic coefficient (C_p) and waterplane coefficient (C_{wp}) of a new hull will be selected at an early stage of design. The characteristics may be selected on the basis of owner/designer experience and preference, operational requirements, the results of appropriate design processes (which would include the use of a design synthesis model), or some combination of the above. After selection of such characteristics, a preliminary hull form definition, consisting of a rough body plan or a three view lines drawing, is prepared. One obvious guiding principle for development of this preliminary hull form definition is that the forebody and afterbody shapes must be compatible. The preliminary development of the afterbody design can then proceed.

Excitation of Vibratory Forces

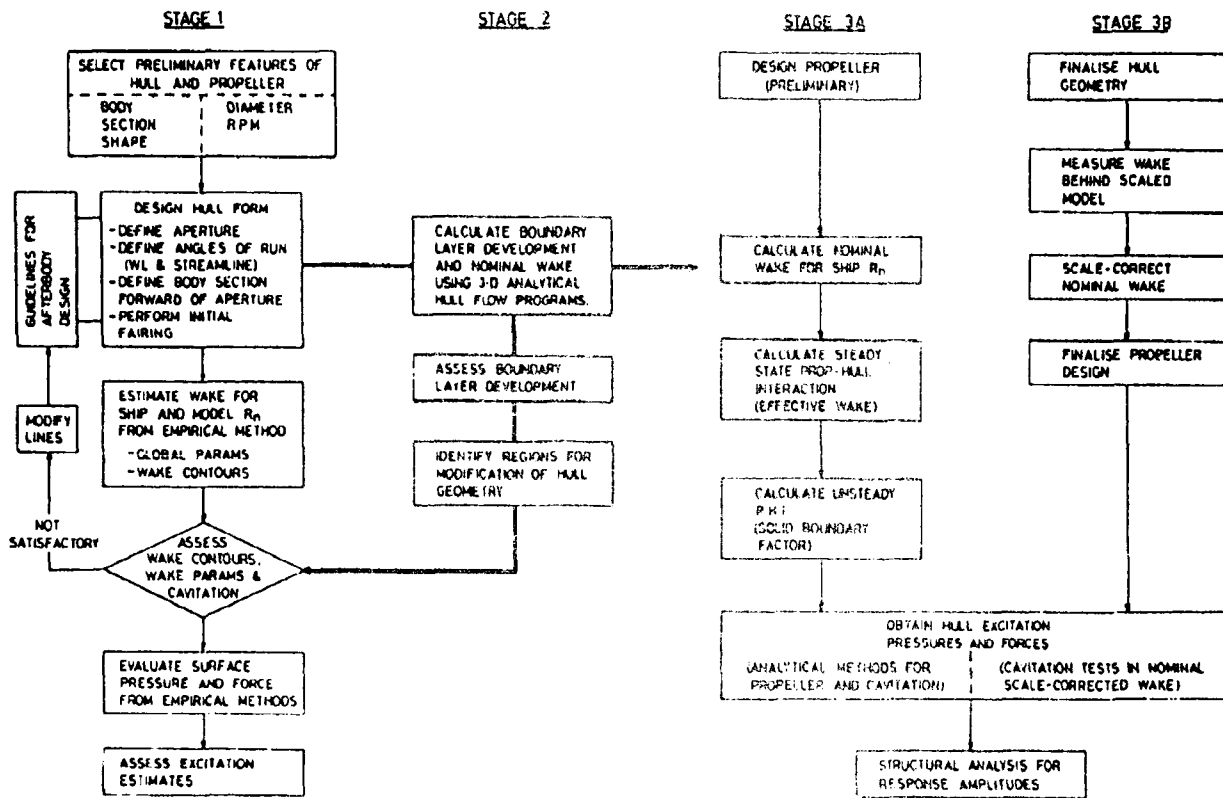

Figure 3-1

Overall Hydrodynamic Design Sequence for Minimization of Propeller-Induced Vibratory Forces [3-1]

First, the basic type of afterbody must be selected (bearing in mind the requirement for compatibility with the forebody). For single-screw ships, the basic types of afterbody may be categorized as follows:

- “Closed” stern, with relatively tall, narrow sections (which may vary from U-shaped to V-shaped) in way of the skeg or “deadwood.”
- “Closed” stern, with bulbous sections (e.g., a Hogner stern) in way of the skeg or “deadwood.”
- “Open” stern, with a strut supported, exposed propeller shaft; this type of afterbody can feature an “integral” skeg or an “appended” skeg.

For twin-screw ships, the basic types of afterbody may be characterized as follows:

- “Open” stern, with strut supported, exposed propeller shafts and a centerline skeg (“integral” or “appended”)
- Stern with bossing-enclosed shafts, with or without a centerline skeg.
- Twin-skeg stern, with shafts enclosed in the skegs, without a centerline skeg.

Ship Vibration Design Guide

A considerable number of variations are possible within the above listed categories; for instance, the selection of relatively large, relatively slow turning propellers can result in afterbody configurations, which are quite different from those associated with "normal" propeller diameter and RPM values.

Guidelines relative to selection of afterbody type, with the goal of reducing the potential for propeller-induced vibratory forces are as follows:

- Open-stern configurations, in general, yield smaller wake fraction (W) values and smaller values of wake non-uniformity than do closed-stern configurations. The ranges of wake fraction values for various types of ships are presented in Figure 3-2. The importance of minimizing wake non-uniformity, with respect to minimization of propeller-induced vibratory forces, is illustrated in Figure 3-3. This figure, based on real ship data, shows that with small values of the wake non-uniformity criterion, the propeller(s) can operate at a greater range of cavitation numbers (greater range of thrust loadings) and still provide acceptable

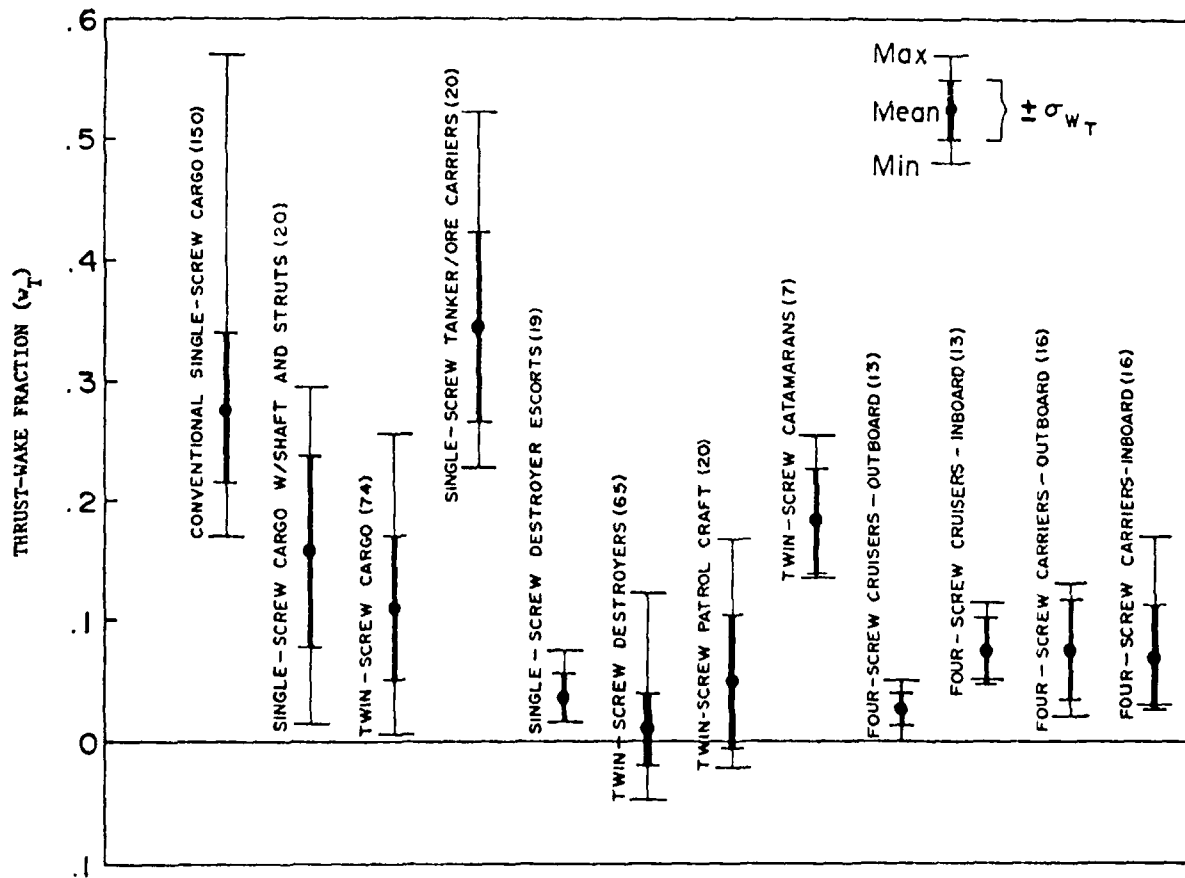

Figure 3-2

Wake Fraction of Various Types of Ships Based on Results of Model Tests at DTRC [3-2]

- + Ships with acceptable vibration characteristics
- Ships with unacceptable vibration characteristics

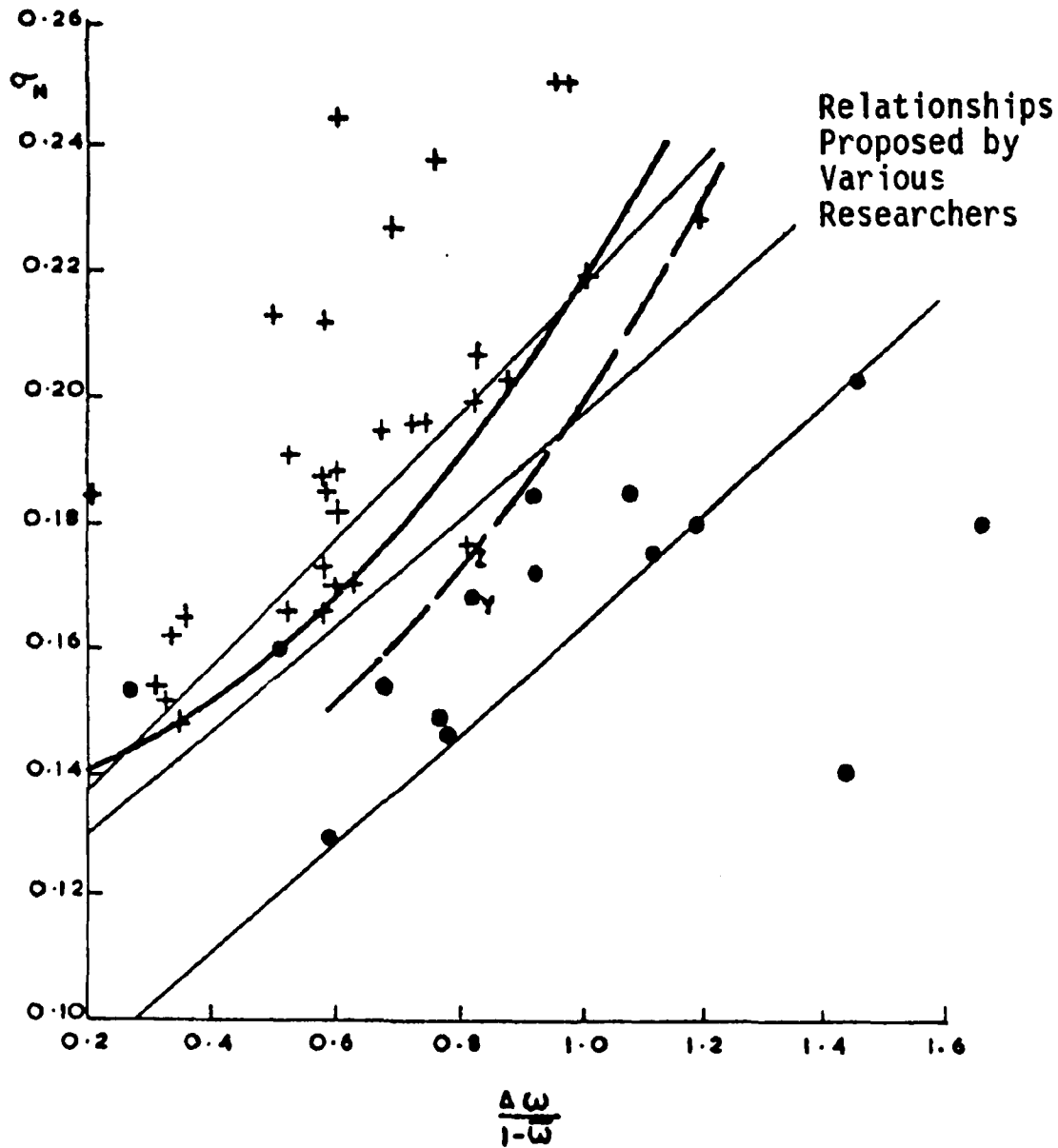

Figure 3-3

Relationship for Cavitation Number Versus Wake Non-Uniformity Parameter, with Data Points Based on Actual Ship Performance and on Model Test Wake Surveys for these Ships [3-3]

vibration qualities. The relative uniformity of the wake of an open-stern, single-screw hull form, as compared to the wakes of a conventional, closed-stern single-screw hull form and a Modified-Hogner (bulbous), closed-stern single-screw hull form, is illustrated in Figures 3-4, 3-5, and 3-6 (respectively). (As a result of model tests of the three hull forms depicted in Figures 3-4, 3-5, 3-6, a modification of the open-stern hull form was selected for the ship and this ship was built and used in commercial service. The final configuration is illustrated in Figure 3-7. The goal of the hull form selection and development process had, in this case, been to produce a 90,000 ton, single screw, 45,000 SHP ship for which the propeller-induced vibratory forces would be minimized. This goal was achieved. Thus, this design study, partially documented by Noonan [3-4], serves as one example of the hull form selection/development approach being discussed herein.)

- Open-stern configurations, in general, yield smaller values of thrust deduction fraction (t) than do closed-stern configurations, as illustrated in Figure 3-8. This relates to minimization of propeller-induced vibratory force in that a smaller value of t means a smaller value of mean thrust, and in turn, smaller values of propeller blade loading.
- It is generally advantageous to avoid high values of hull block coefficient (C_B); for example, the increase in wake non-uniformity with increasing C_B , for closed-stern single-screw hull forms, is illustrated in Figure 3-9.

After selection of the afterbody type, the shape of the afterbody can be developed. Guidelines for development of the shapes of the various types of afterbodies are presented below.

3.1.3 Development of Afterbody Shape

3.1.3.1 Design of Closed-Stern Afterbodies for Single Screw Ships

Applicable guidelines are as follows:

- The ideal wake is that which gives constant wake velocities concentric to the propeller center. This can only be achieved in the case of a propeller working behind a tapered, circular cross-section hull form (such as the afterbody of a modern, single-screw submarine). For "conventional" surface ships, this condition can be approximated by using a bulbous stern (e.g., a Hogner stern).
- For "conventional" ships, the waterline exit angles should be moderate and the differences between this angle at waterlines above and this angle at the waterlines below the propeller center should be minimized. Extremely V-shaped sections can result in relatively large differences in waterline exit angles above and below the propeller center and should be avoided. Conversely, U-shaped aft sections can provide more uniform waterline exit angles; such sections are especially recommended for relatively short, "full," single-screw ships.

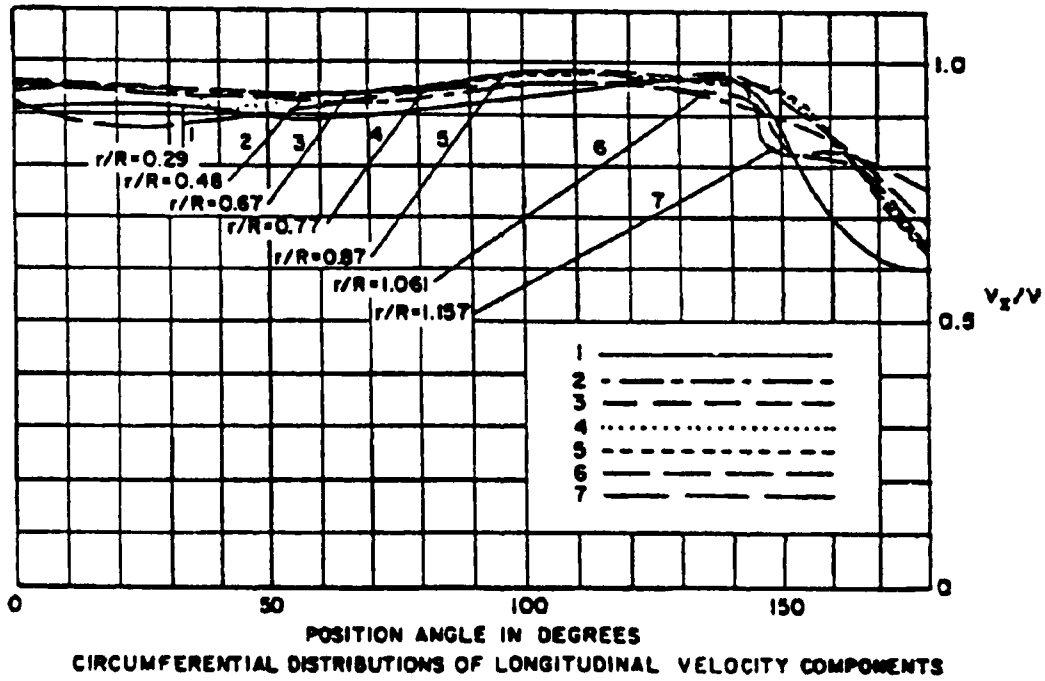
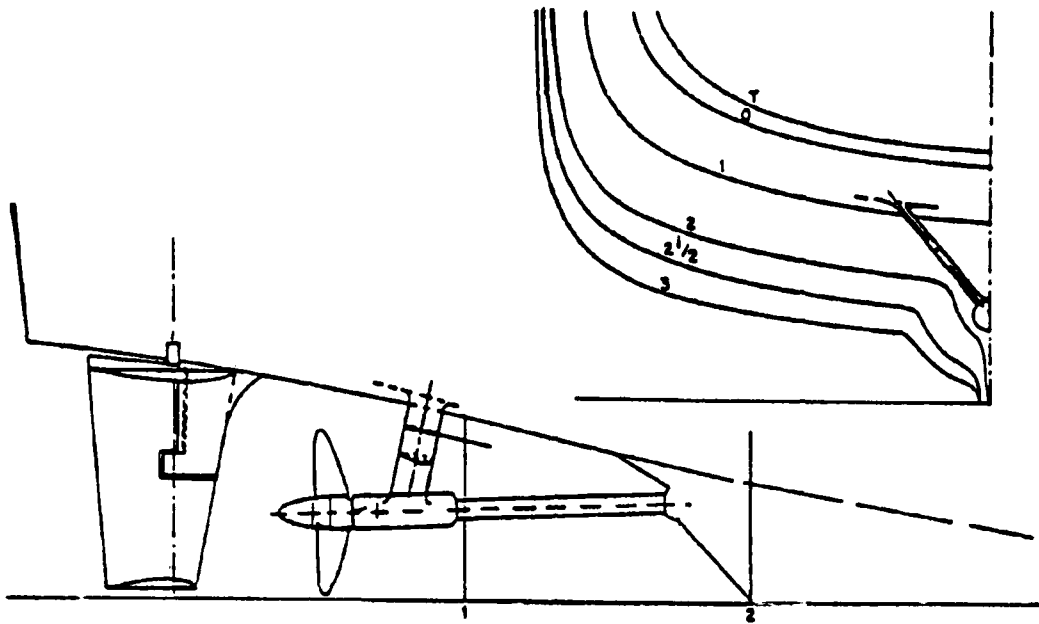

Figure 3-4
 Afterbody Configuration and Wake Characteristics
 of an Open-Stern Single-Screw Ship

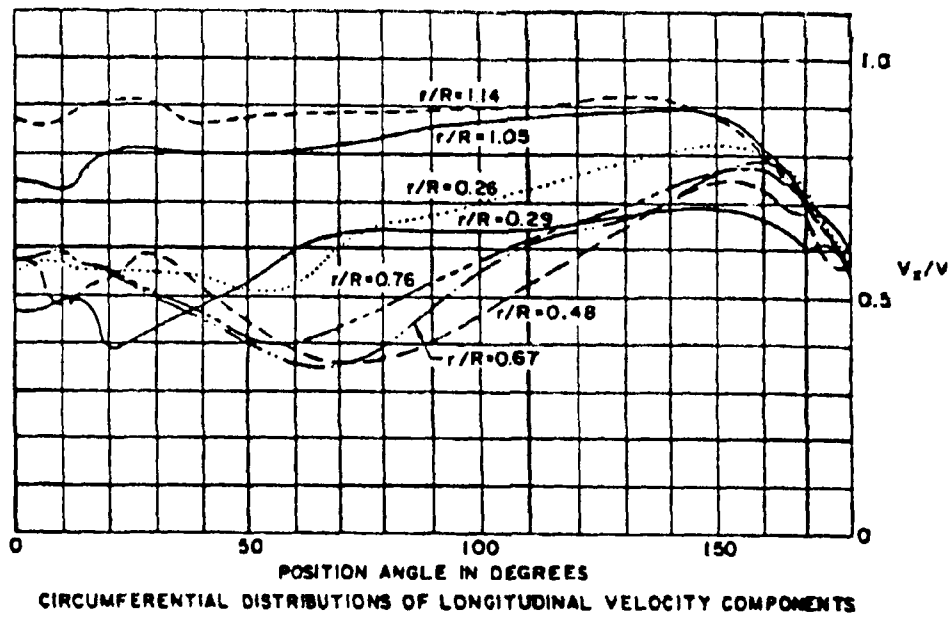
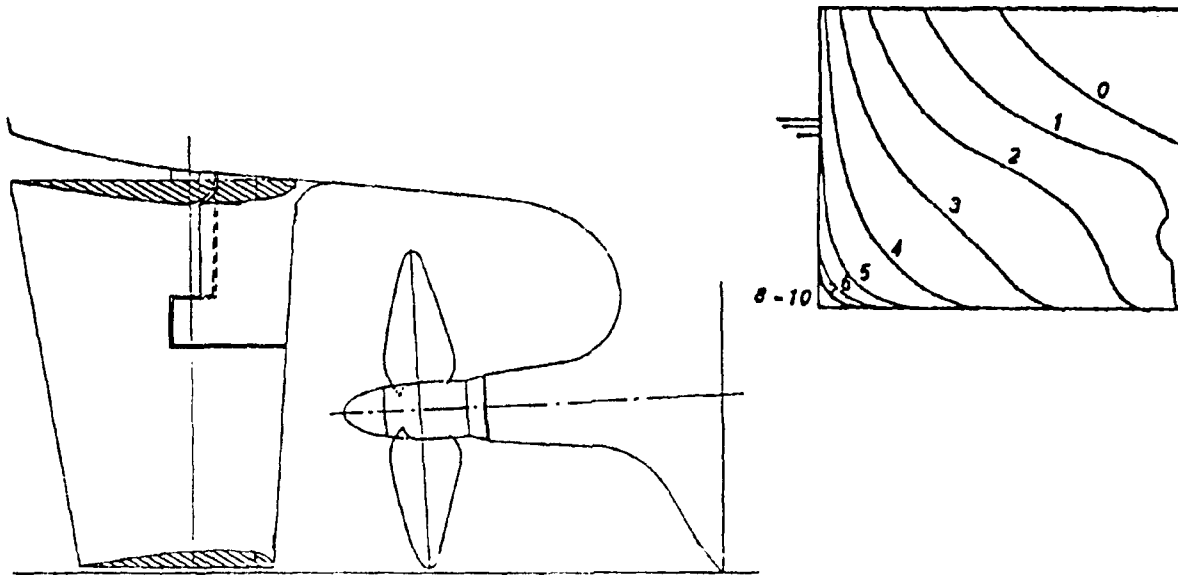

Figure 3-5
 Afterbody Configuration and Wake Characteristics
 of a Conventional, Closed-Stern Single-Screw Ship

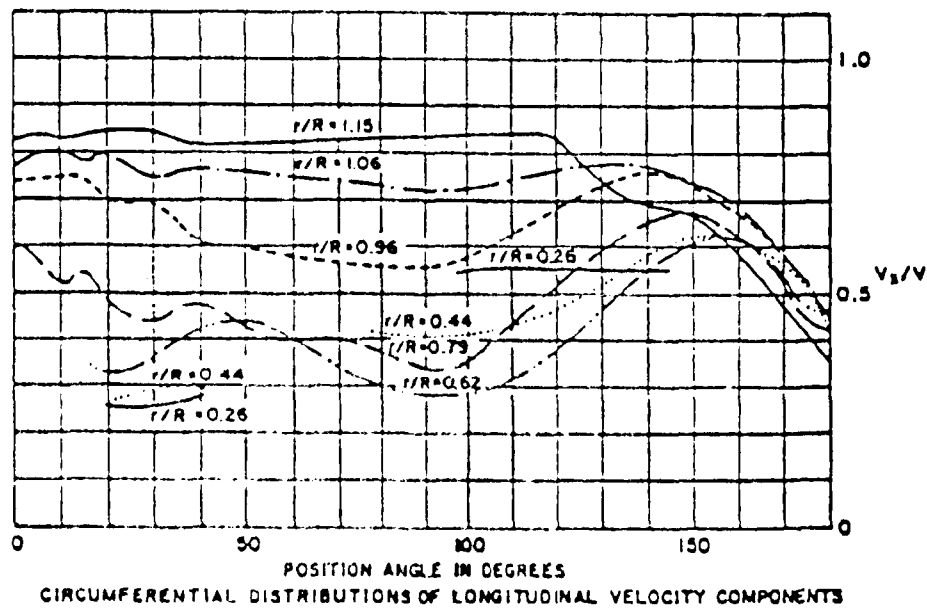
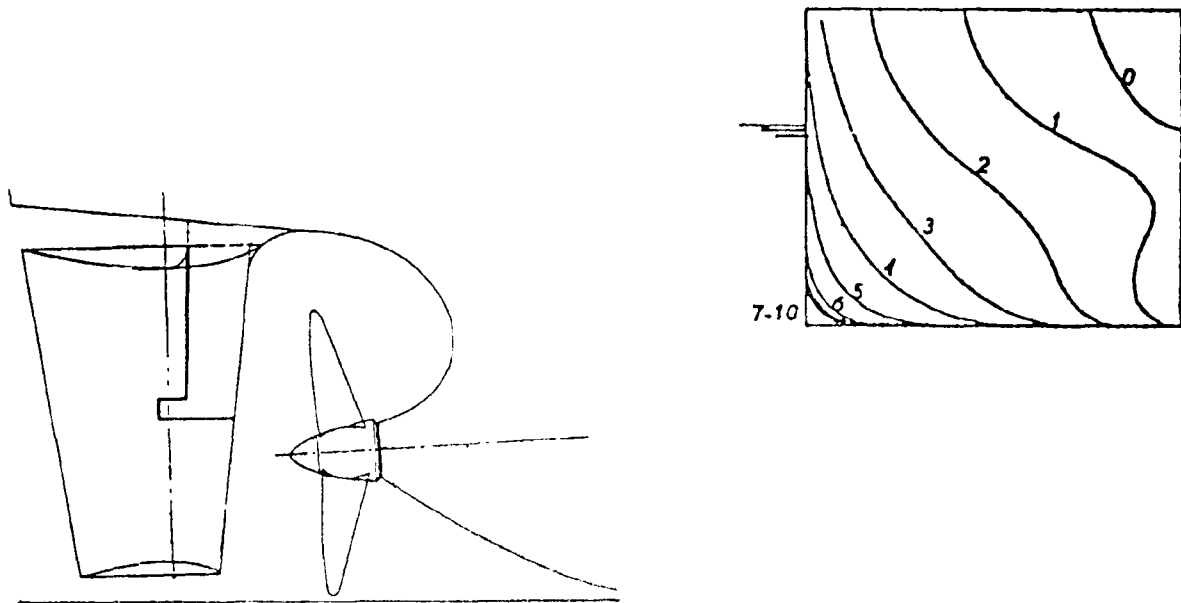

Figure 3-6

Afterbody Configuration and Wake Characteristics
of a Modified-Hogner, Closed-Stern Single-Screw Ship

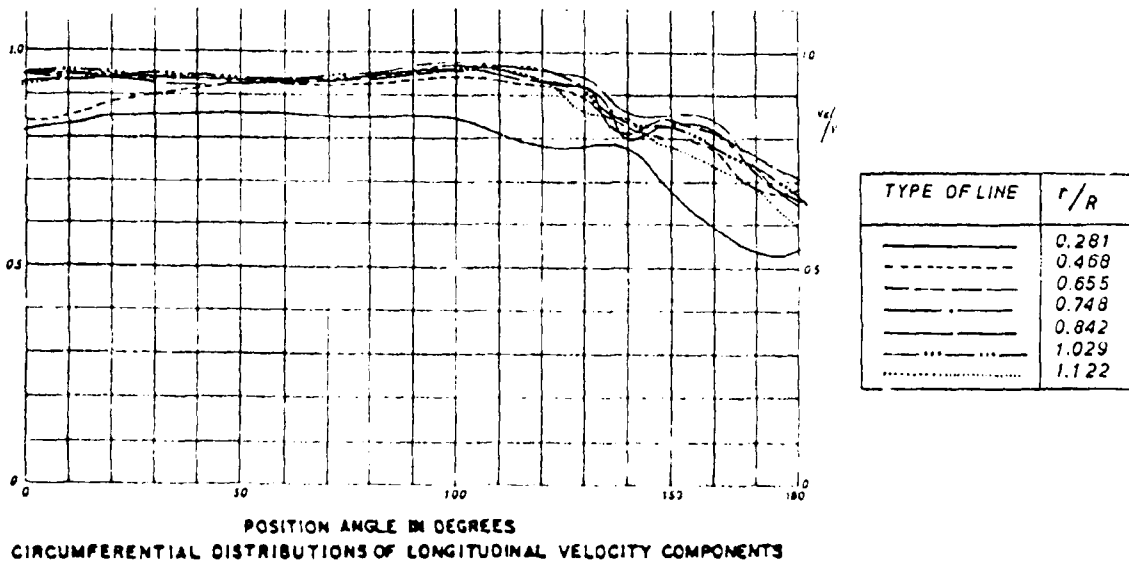
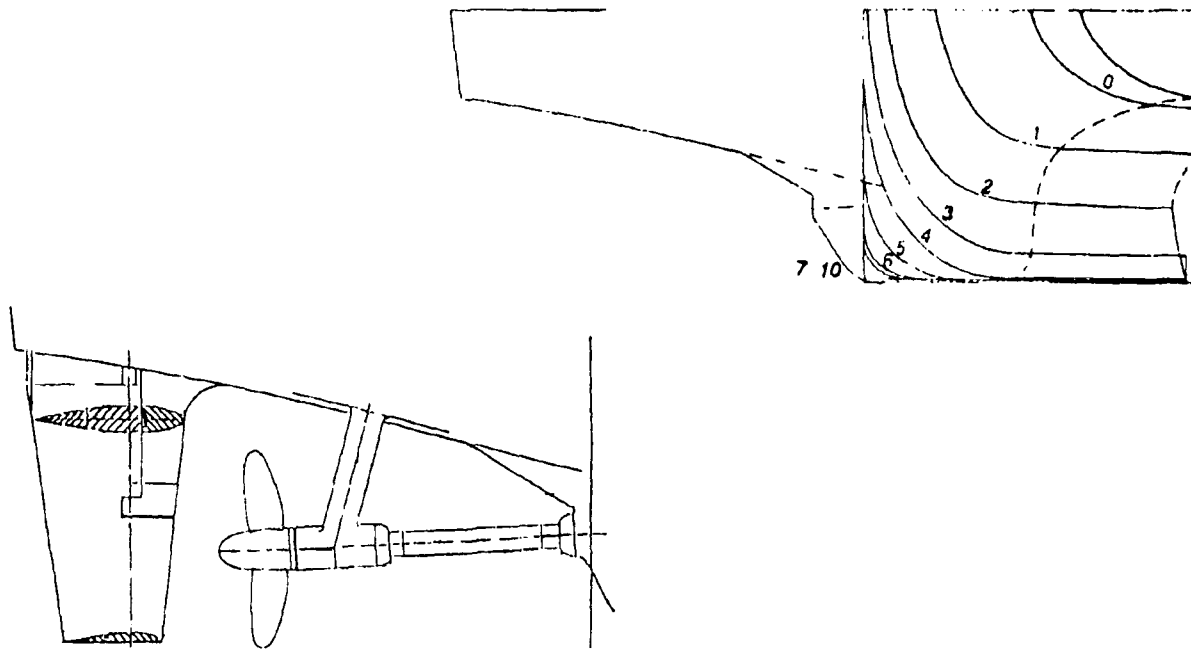

Figure 3-7
 Selected Afterbody Configuration for an LNG Ship,
 and Associated Wake Characteristics

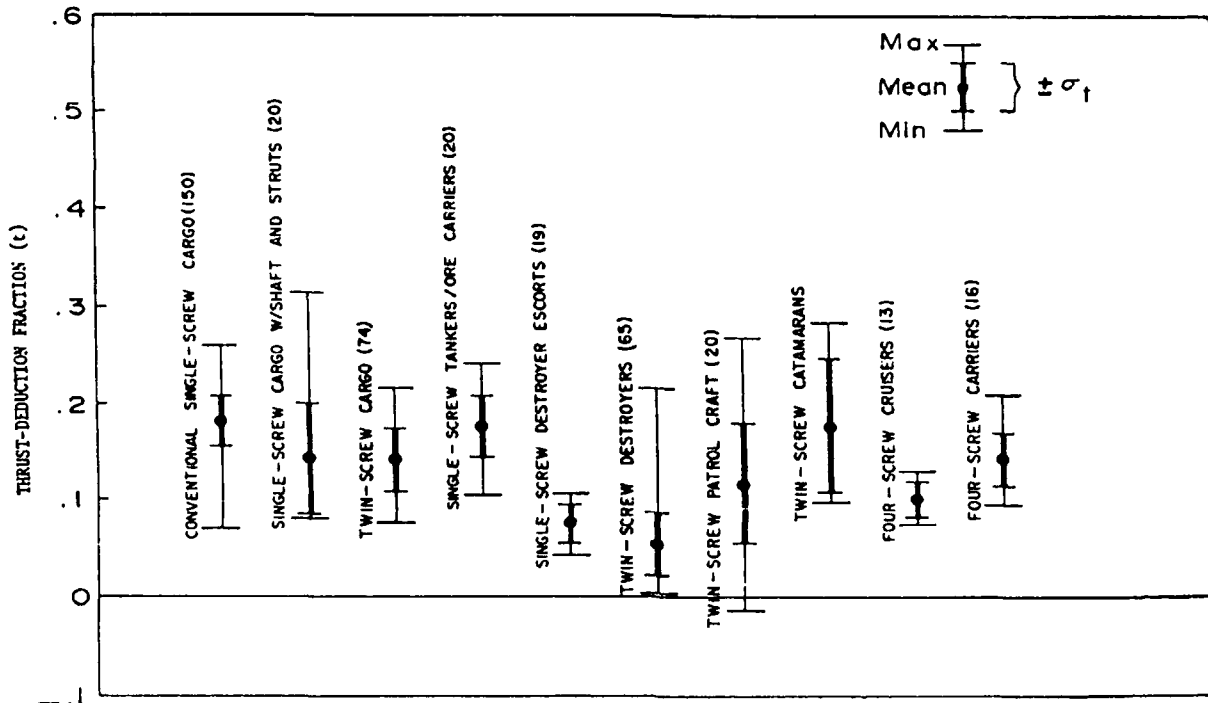

Figure 3-8

Thrust-Deduction Fraction of Various Types of Ships Based on Results of Model Tests at DTRC [3-2]

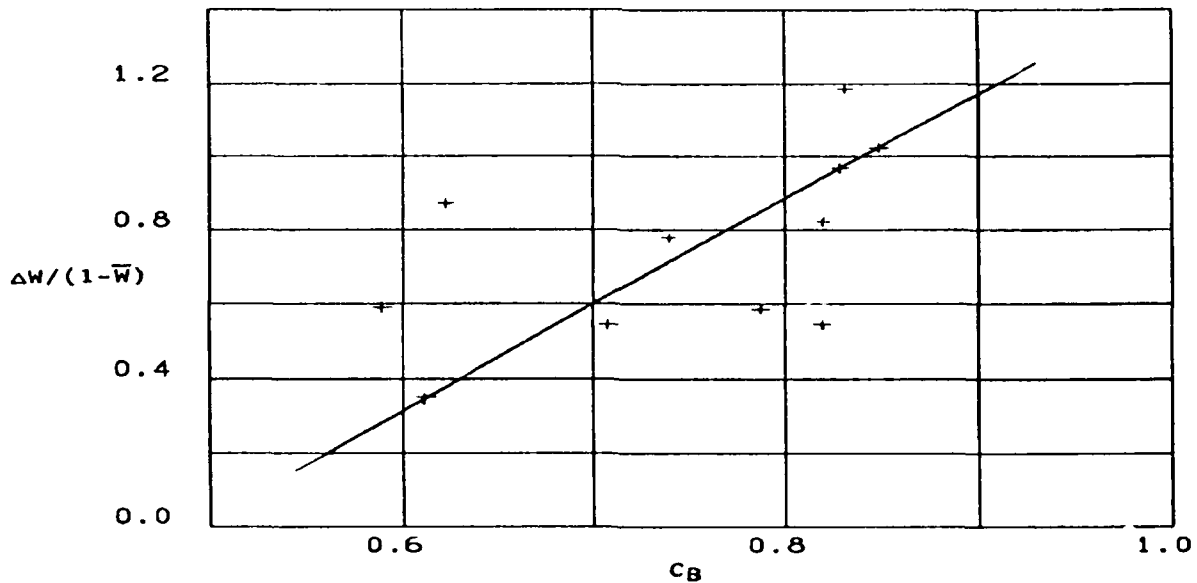

Figure 3-9

Criterion Plot for Gross Estimate of Wake Non-Uniformity Parameter Value Based on Block Coefficient (Applicable to Closed-Stern, Single-Screw Ships Only) [3-3]

Ship Vibration Design Guide

- Concerning the relationship between afterbody shape and flow characteristics at the propeller plane, one set of information applicable to single-screw ships is that presented by Ward [3-1]; criteria from that reference are depicted in Figure 3-10. This includes a criterion for waterline exit angles (angles of run) and for the angle between flow lines aft. For the latter criterion, it is suggested by Ward that the value of the angle between flow lines, divided by the hull form's block coefficient, should be less than 30.
- With respect to waterline endings, or aft flow line endings, relationships between the maximum and minimum wake at 0.8R and the angle between the flow lines, ending at 0.8R in the 12 o'clock position, have been suggested by Jonk and v.d. Beek [3-5]. Figure 3-11 illustrates these relationships. The suggested relationship for $\Delta W_{0.8R}$ (difference of maximum and minimum value of wake at 0.8R), as a function of the half angle of the flow lines at 0.8R in the 12 o'clock position ($\alpha_{0.8R}$), for normal aperture clearances, can be expressed as follows:

$$\Delta W_{0.8R} = \frac{\alpha_{0.8R} + 29}{83}$$

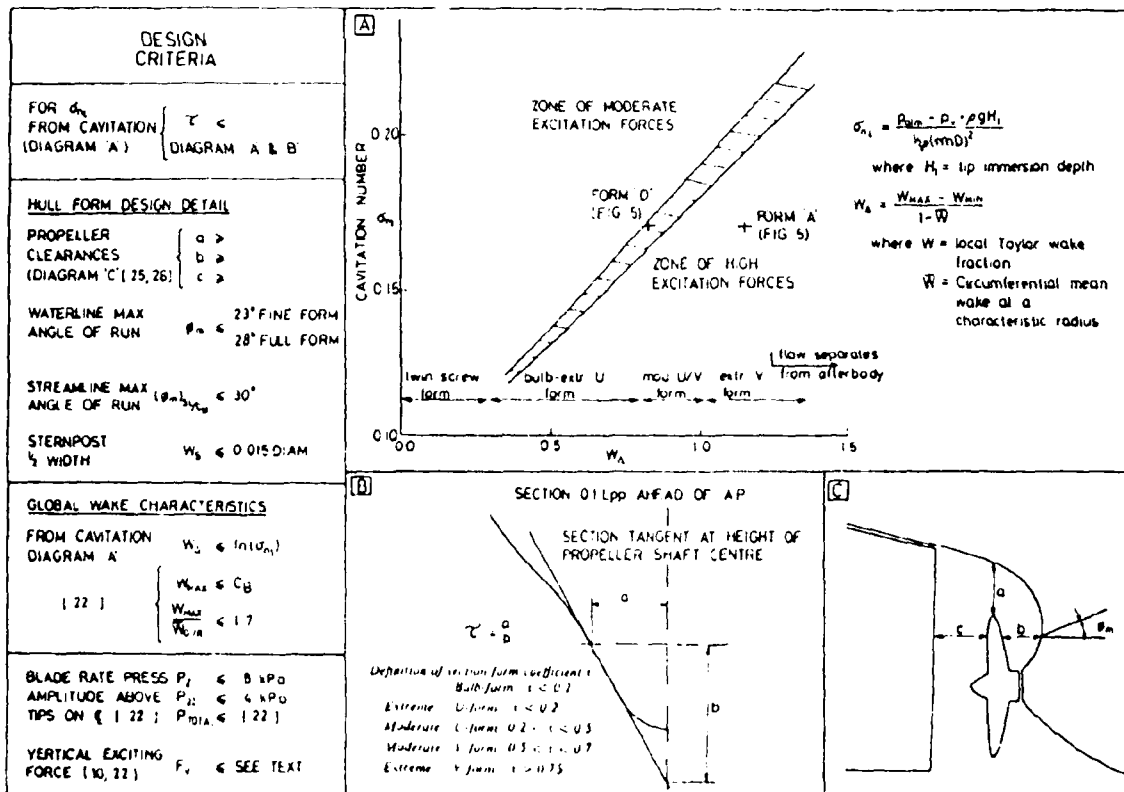

Figure 3-10

Suggested Criteria for Afterbody Design (reference numbers refer to [3-1])

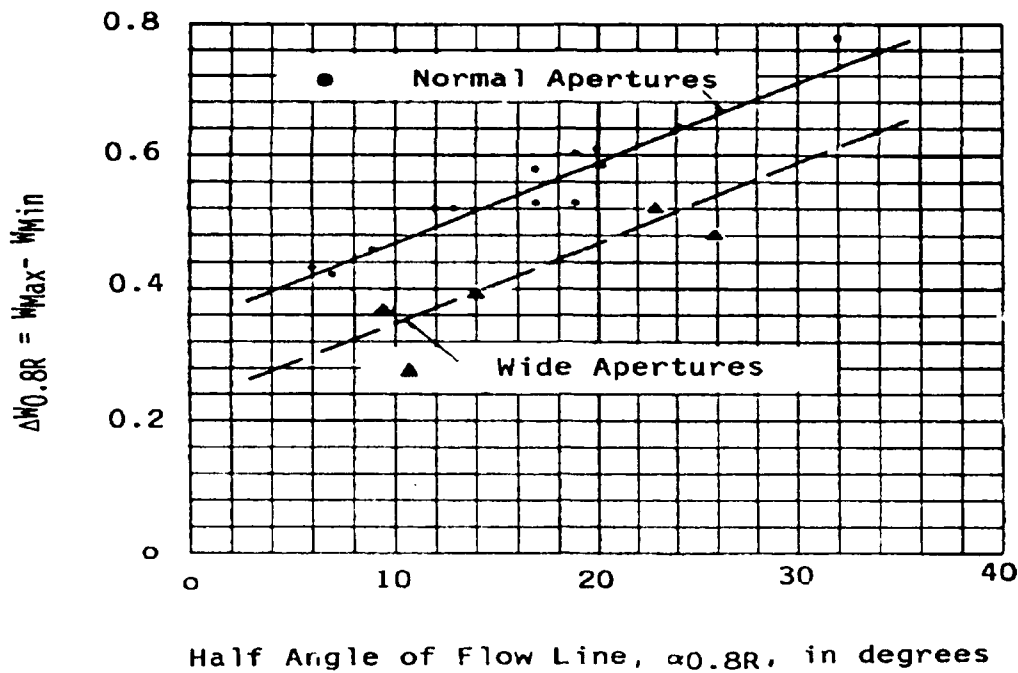

Figure 3-11

Suggested Relationships Between Axial Wake Variation and Half Angle of Flow Line at 0.8R [3-5]

In the case of very wide apertures (considerably greater than those suggested by the rules of classification societies), the suggested relationship is as follows:

$$\Delta W_{0.8R} = \frac{\alpha_{0.8R} + 19}{83}$$

Jonk and v.d. Beek have also suggested a "Difficulty Index," applicable to the propeller in combination with the afterbody (represented by the half angle of the flow line at 0.8R), as follows:

$$D.I. = \frac{T + 0.61 (ND^3 V_s) (\alpha_{0.8R} + 29)/83}{(h + 10) D^2}$$

where:

- $D.I.$ = Difficulty Index
- T = thrust, in kilograms
- N = number of revolutions per minute
- D = diameter, in meters

Ship Vibration Design Guide

- V_s = ship's speed, in knots
 $\alpha_{0.8R}$ = half angle of flow line at $0.8R$ in the 12 o'clock position, in degrees
 h = height of water column above propeller tip, in meters

Jonk and v.d. Beek provide values of this "Difficulty Index" for a number of ships with known (acceptable and unacceptable) vibration characteristics. These computed values indicate that the value of the "Difficulty Index" should be about 740 or less, in order to ensure that the ship will have acceptable vibration characteristics.

- It may be necessary to roughly estimate the value of the previously mentioned "wake non-uniformity" parameter during the early stages of hull design. One criterion for this parameter is that suggested by Odabasi and Fitzsimmons [3-6] and presented in Figure 3-12. This criterion is nearly the same as that suggested by Ward [3-3] (see Figure 3-10). If the value of $\Delta W/(1-\bar{w})$ cannot be estimated from model test data for similar hull/appendage configurations, the plot presented in Figure 3-9 can be used to provide a very gross estimate of $\Delta W/(1-w)$. (The above discussed wake non-uniformity information is, of course, primarily applicable to closed-stern, single-screw hull forms.)

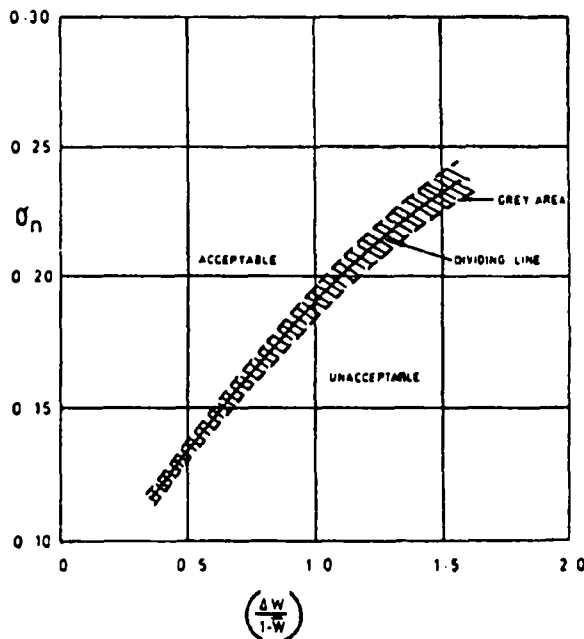

$$\sigma_n = \frac{9.903 - D/2 - Z_p + T_A}{0.051(\pi n D)^2}$$

where:

- D = Propeller Diameter
 Z_p = Distance between propeller shaft axis and ship baseline
 T_A = Ship draft at aft perpendicular
 ΔW = Wake variation
 \bar{W} = Taylor wake fraction

(All values in S.I. units)

Figure 3-12

Suggested Non-Uniformity Criterion [3-6]

3.1.3.2 Design of Open-Stern Afterbodies

Certain guidelines have been developed from experience in the design of naval ships, primarily; these are as follows:

- The angle between buttock lines (in the vicinity of the shaft centerline) and the baseline should not exceed 10 degrees.
- The angle between buttock lines (in the vicinity of the shaft centerline) and the shaft centerline at the hull/shaft intersection should not exceed 12.5 degrees.
- The angle between buttock lines (in the vicinity of the shaft centerline) and the shaft centerline, in way of the propeller plane, should not exceed 5 degrees.

(The above guidelines apply primarily to open-stern, twin-screw ships; however, they can also apply, in general to open-stern, single-screw ships and to twin-screw ships featuring "buttock flow" sterns fitted with shaft bossings or bossing/strut configurations.)

3.1.3.3 Selection of Propeller-to-Hull Clearances

Propeller-to-hull clearances must be large enough to avoid any undue interference with the circulation pattern around the blade as it passes the hull, skeg and rudder boundaries. Note that the pressure field around each blade rotates with the blade and gives rise to fluctuating forces on those boundaries, which are close enough to the blade to feel the effects of the rotating pressure field.

The clearance between the propeller tips and the hull should be selected in order to minimize propeller-induced fluctuating hull pressures.

Three components of the propeller-induced hull pressures are normally calculated separately and then added together. These components are as follows:

- Pressures due to the thickness of the rotating propeller blades
- Pressures due to the hydrodynamic loading of the propeller blades
- Pressures due to the thickness and thickness variation with time of the area of cavitation on the propeller blades

The pressures induced by the thickness and the loading of the propeller blades have a sinusoidal character with the blade frequency being dominant. For the non-cavitating propeller, there is a strong decay in the amplitude of the pressure with increasing propeller clearance. For example, the calculations for one particular propeller showed a decay proportional with about $1/r^3$, where r is the distance between the point considered and the propeller shaft. The behavior of the pressures originating from blade cavitation is usually quite different. First of all, these pressures have a strong fluctuating character. Secondly, the blade frequency components and the higher harmonics can have a considerable magnitude. Finally, for the case with blade

Ship Vibration Design Guide

cavitation, the decay with increasing propeller tip clearances is much smaller. For example, for one particular propeller investigated, the decay was proportional to $1/r^2$. The net result is that the excitation forces can reach values much higher than those generated when only the blade thickness and blade loading components are involved.

For most naval ships, the propeller to hull clearance (commonly called "tip clearance") is selected to be at least 0.25 times the propeller diameter (D_p). Naval ship propeller tip clearance, plotted versus a gross propeller loading parameter, is presented in Figure 3-13. This information, together with full scale evaluations of ship vibration characteristics, indicates that vibration problems can probably be avoided by using a tip clearance value of $0.25 D_p$.

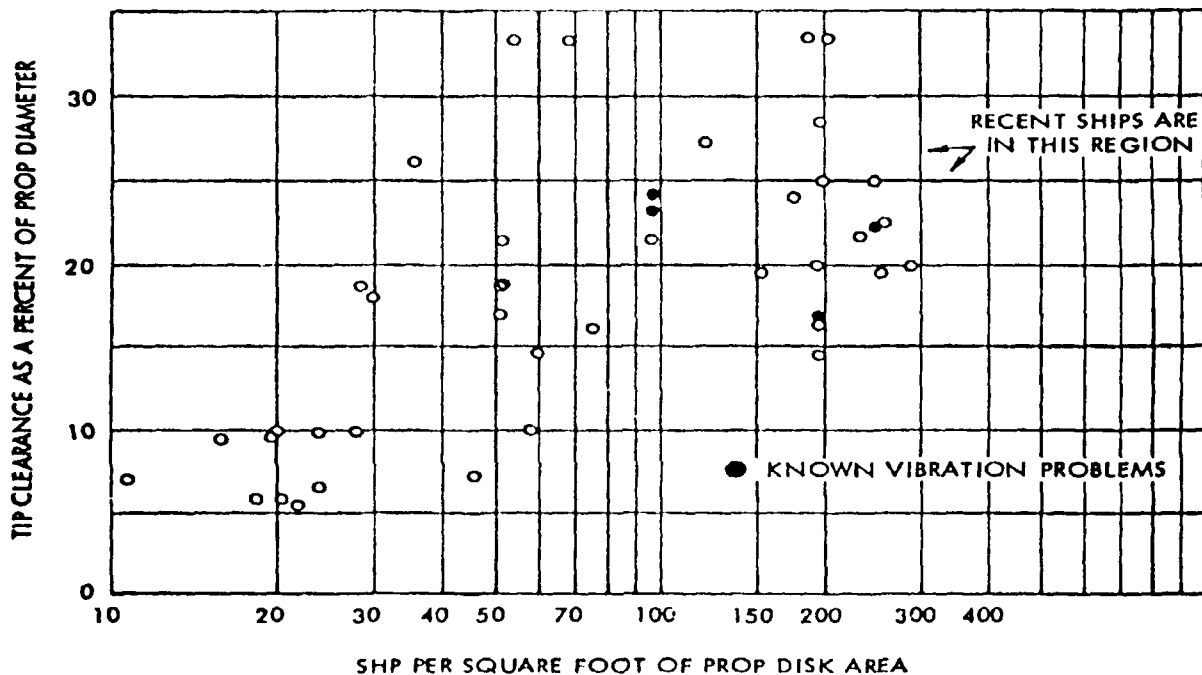

Figure 3-13

Tip Clearance versus Propeller Loading for U.S. Navy Ships [NAVSEA]

For ships built to commercial standards, the classification societies recommend the propeller tip clearance. One example of such recommendations, for a particular closed-stern, single-screw ship, is given in Figure 3-14. It is interesting that the recommended tip clearances in this example, for the different values of propeller diameter, amount to roughly constant percentages of propeller diameter. The classification societies also provide guidance for propeller tip clearance for twin-screw ships. The guidance provided by three classification societies is summarized in Table 3-1. Application of this guidance to an example ship (the T-AO 187 design, which at the time an analysis of clearances, etc., was carried out, featured twin, 90 RPM, 24 ft. diameter propellers) yielded the recommended minimum propeller clearances as shown in Table 3-2. This table also indicates the slight reduction in recommended clearances that would accompany the selection of five-bladed instead of four-bladed propellers for the example ship.

Tip clearance relationships recommended by Classification Societies

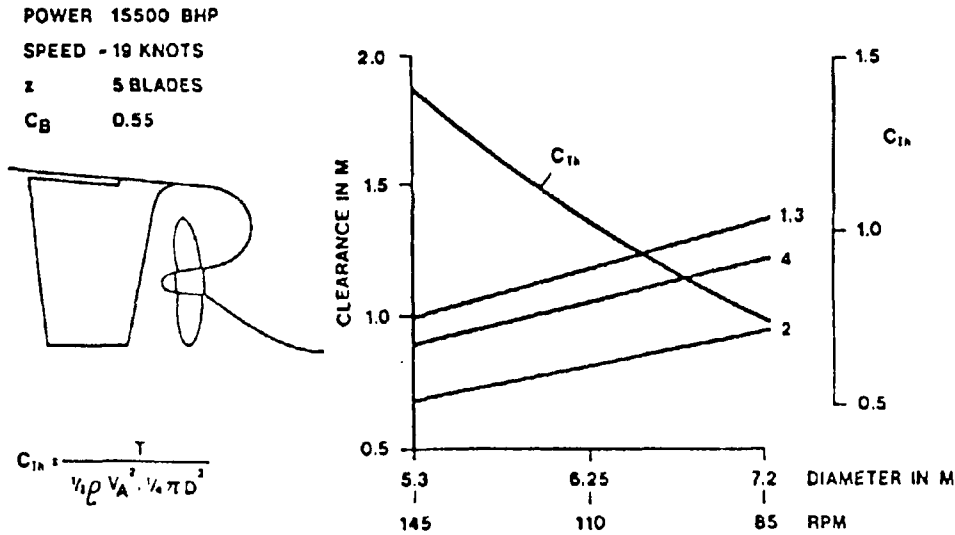

Figure 3-14

Tip Clearance versus Propeller Diameter and Blade Loading as Recommended by Several Classification Societies for a Particular Ship Design [3-5]

For open-stern, twin-screw ships with strut-supported shafts, one significant factor related to selection of propeller tip clearance is the thickness of the boundary layer.

In this regard, Todd [3-7] discusses the work of van Lammeren, who developed a formula based on the assumption that the tip clearance should be equal to 0.8 times the thickness of the boundary layer in way of the propellers. For a ship the size of the T-AO 187, for example, this formula would yield a tip clearance of 30 inches, or 0.104 D_p . In his study of some 20 twin-screw ships, covering a length range of 350 to 750 feet, Todd noted clearances greater than values suggested by van Lammeren; for these ships, the largest clearances can be represented by the following expression:

$$C = .08 L_{PP} - 5.0$$

Where C is the clearance, in inches, and L_{PP} is the ship length (between perpendiculars), in feet. Thus, for the above mentioned example ship (T-AO 187):

$$\begin{aligned} C &= (.08 \times 633) - 5.0 \\ &= 45.64 \text{ inches} \\ C/D_p &= 45.64 / (24 \times 12) \\ &= 0.158 \end{aligned}$$

Table 3-1 Classification Society Guidance on Propeller Clearance

Classification Society	Number of Propellers	Tip Clearance	Longitudinal Clearance to Blade at 0.7R
Det Norske Veritas	1	$(0.24 - 0.01z) D_P$	$(0.35 - 0.02z) D_P$
	2	$(0.30 - 0.01z) D_P$	No guidance given
Bureau Veritas	1	Greater of $(0.65 \alpha) D_P$ or $0.10 D_P$ for $z = 4$	1.5 times tip clearance
		Greater of $(0.55 \alpha) D_P$ or $0.10 D_P$ for $z = 5$	1.5 times tip clearance
	2	Greater of $(0.65 \alpha) D_P$ or $0.20 D_P$ for $z = 4$	Greater of tip clearance or $0.15 D_P$
		Greater of $(0.55 \alpha) D_P$ or $0.16 D_P$ for $z = 5$	Greater of tip clearance or $0.15 D_P$
where: $\alpha = \frac{(C_B \times SHP)^{2/3}}{10L};$ $C_B = \text{Block Coefficient}$ $SHP = \text{Shaft power per shaft, metric HP}$ $L = \text{Ship length, meters}$ $z = \text{Number of blades}$ $D_P = \text{Propeller Diameter}$			
Lloyd's	1	Greater of $(1.0K_1) D_P$ or $0.10 D_P$ for $z = 4$	Greater of $(1.5K_1) D_P$ or $0.15 D_P$ for $z = 4$
		Greater of $(0.85K_1) D_P$ or $0.10 D_P$ for $z = 5$	Greater of $(1.275K_1) D_P$ or $0.15 D_P$ for $z = 5$
	2	Greater of $(1.0K_2) D_P$ or $0.20 D_P$ for $z = 4$	Greater of $(1.0K_2) D_P$ or $0.15 D_P$ for $z = 4$
		Greater of $(0.85K_2) D_P$ or $0.20 D_P$ for $z = 5$	Greater of $(0.85K_2) D_P$ or $0.15 D_P$ for $z = 5$
where: $K_1 = \left(0.10 + \frac{L}{10000}\right) \left(\frac{28C_B \times SHP}{L^2} + 0.3\right)$ $K_2 = \left(0.10 + \frac{L}{10000}\right) \left(\frac{14C_B \times SHP}{L^2} + 0.3\right)$ $C_B = \text{Block Coefficient}$ $SHP = \text{Total installed shaft horsepower}$ $L = \text{Ship length, feet}$			

Table 3-2 Propeller Clearances Recommended by Classification Society Guidance for Example Ship (T-AO)

Classification Society	Number of Propellers	Tip Clearance	Longitudinal Clearance to Blade at 0.7R
Det Norske Veritas	2	0.26D _p for z = 4	No guidance given
		0.25D _p for z = 5	No guidance given
Bureau Veritas	2	0.20D _p for z = 4	0.20D _p for z = 4
		0.16D _p for z = 5	0.16D _p for z = 5
Lloyd's	2	0.20D _p for z = 4	0.18D _p for z = 4
		0.16D _p for z = 5	0.15D _p for z = 5
Note: Example ship had twin, 90 RPM, 24 ft diameter propellers, at this stage of design			

Actually, Todd recommends a tip clearance of $0.2 D_p$ or, in special cases, $0.25 D_p$, for early stage design, for open-stern, twin-screw ships.

Saunders [3-8] also recommends the determination of propeller tip clearance based on an estimated boundary layer thickness at the propeller. In his approach, the nominal thickness of the smooth-hull turbulent boundary layer (δ) can be estimated at the ship's sustained speed, using the following relationship:

$$\delta = 0.38 (x) \left(\frac{\nu}{U_\infty x} \right)^{0.2}$$

where:

x = Distance from bow to propeller, in ft.

ν = Kinematic viscosity (for salt water at 3.5 percent salinity and 59° F, $\nu = 1.2791 \times 10^{-5}$ ft²/sec)

U_∞ = Undisturbed velocity of the water, in ft/sec

Saunders notes that the friction wake velocities in the outer half of the boundary layer are generally less than about one-tenth the ship velocity, which would suggest an acceptable tip clearance of 0.5δ . However, the foregoing estimate of δ is based on a smooth hull, and the expected roughening and fouling of the hull over its service life results in average boundary layer thicknesses in excess of the values that result from the use of the above formula. He, therefore, recommends minimum propeller tip clearances of about 0.7δ . Thus, for the 20-knot T-AO 187 (for example):

x = 600 feet (approximately)

U_∞ = 33.78 ft/sec

Ship Vibration Design Guide

$$\begin{aligned}\delta &= (0.38) (600) ((1.2791 \times 10^{-5}) / (33.78 \times 600))^{0.2} \\ &= 3.30 \text{ feet} \\ 0.7 \delta &= 2.31 \text{ feet} \\ 0.7 \delta / D_p &= 2.31/24 = 0.096\end{aligned}$$

Tip clearances based on boundary layer thickness as recommended by Todd and Saunders (which result, for example, in 0.104 and $0.096 D_p$, respectively, for the T-AO 187) permit the propeller tip to penetrate the outer boundary layer; such tip clearances must be considered to be minimum values since it is preferable to keep the tip out of the boundary layer, especially in ships with relatively highly loaded propellers.

Continuing the reference to the example ship, the tip clearance shown on the T-AO 187 drawings is $0.20 D_p$, based on $D_p = 24$ feet. This clearance was considered to be satisfactory in light of the guidance provided by Bureau Veritas, Lloyd's, and Todd and Saunders. The larger clearance recommended by Det Norske Veritas ($0.26 D_p$ for four-bladed propellers and $0.25 D_p$ for five-bladed propellers) was considered to be too conservative; the Det Norske Veritas recommendations are based on moderately cavitating propellers, whereas the 24 ft. T-AO 187 propellers had relatively light thrust loading and would have been relatively free of cavitation.

Concerning the longitudinal clearance between the skeg (deadwood), struts, or bossings and the leading edge of the propeller blades, classification society guidance is presented in Table 3-1. This guidance applies primarily to closed-stern, single-screw ships and twin-screw ships with bossings. When applied to the above mentioned example ship (T-AO 187 with twin, 90 RPM, 24 ft. diameter propellers), a longitudinal clearance of about $0.20 D_p$ is indicated. Saunders [3-8] recommends a longitudinal clearance of $0.20 D_p$ or the propeller chord length at $0.7R$, whichever is greater. For the example ship (T-AO 187) propeller, the range of recommended longitudinal clearance would be from about $0.27 D_p$ (for five-bladed propellers with blade area ratio of 0.50) to about $0.35 D_p$ (for four-bladed propellers with blade area ratio of 0.66), using Saunders recommendation and assuming Wageningen B Series propellers. Saunders indicates, however, that longitudinal clearances, like tip clearances, may be reduced from the average recommended values when thrust loadings are light. The example ship (T-AO 187) drawings showed a longitudinal clearance between the centerplane of the propeller (a plane at right angles to the shaft centerline at the propeller center) and the aft edge of the struts of six feet at $0.7R$ of the propeller, which corresponds to $0.25 D_p$; the clearance to the leading edge of the blades would depend on blade geometry, including blade rake. Studies reported by Lewis in Chapter 10 of Principles of Naval Architecture [3-9] tend to support these above noted values of longitudinal clearance for the example ship. In the case of another example ship (the DD963), the longitudinal clearance (aft edge of strut to propeller centerplane) is about $0.41 D_p$; the approximate clearance between the strut and the propeller blades, at $0.7R$, is $0.32 D_p$. For this ship, however, the blade thrust loading coefficient is considerably greater than that for the other example ship (T-AO 187).

Additional guidance on selection of propeller tip clearance and longitudinal clearance, based on data from actual operating single-screw, closed-stern ships, has been given by Vossnack and Voogd [3-10]; this guidance is presented in Figures 3-15 and 3-16.

Based on the discussion presented above, it is obvious that many considerations affect the selection of propeller-to-hull clearances. For early stage design purposes, it is recommended that a tip clearance of $0.25 D_p$ and a longitudinal clearance of $0.5 D_p$ between the trailing edge of the skeg (deadwood) or strut and the centerplane of the propeller be selected.

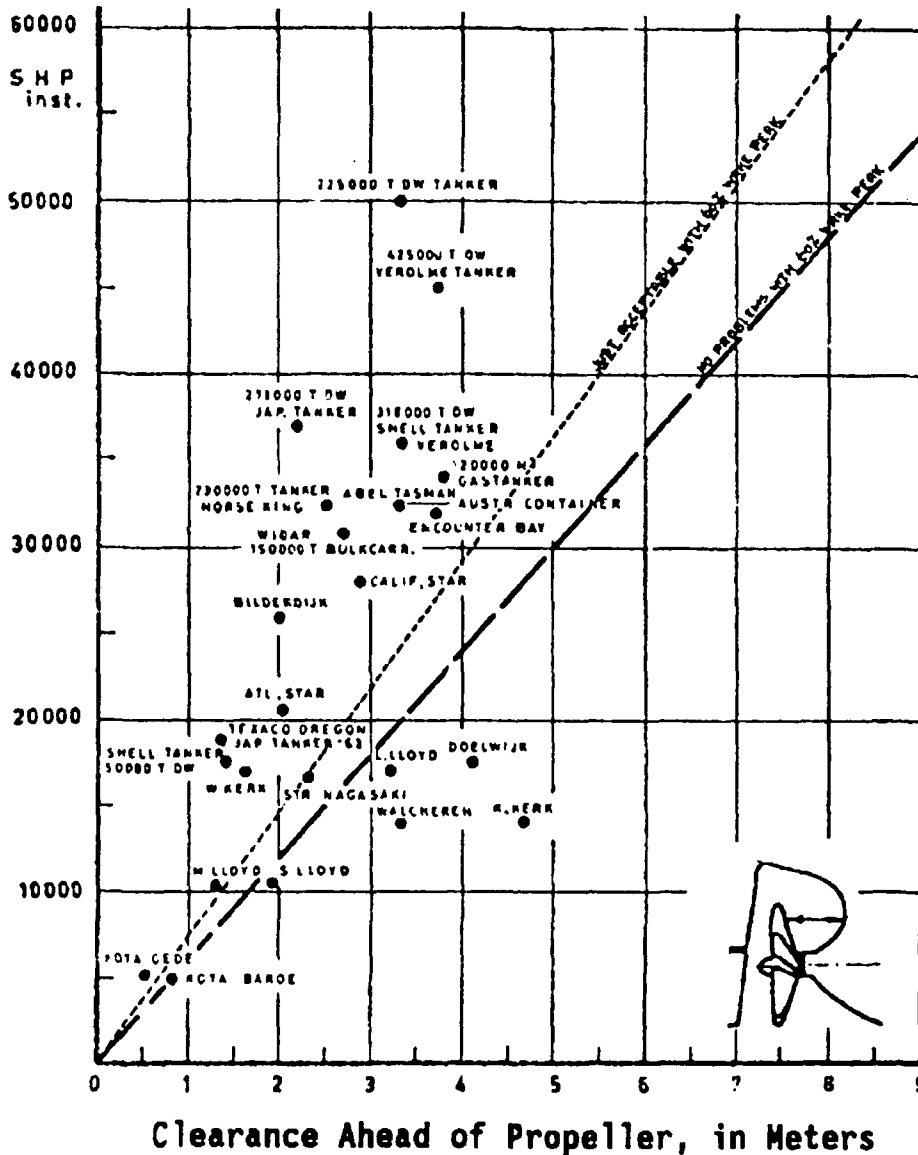

Figure 3-15

Guidance for Selection of Clearance Ahead of Propeller Based on Data from Actual Operating Ships [3-9]

Ship Vibration Design Guide

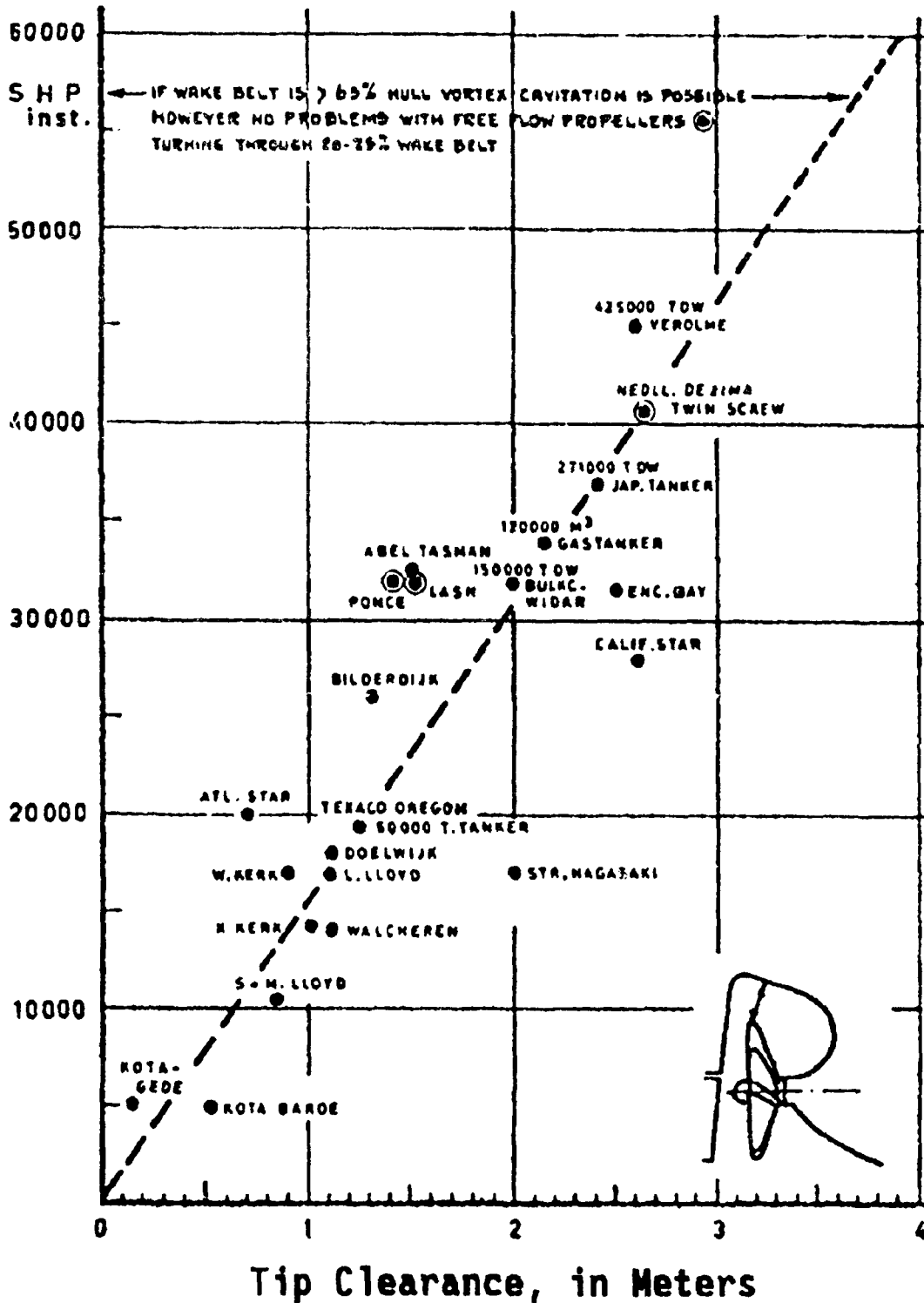

Figure 3-16

Guidance for Selection of Propeller Tip Clearance Based on Data from Actual Operating Ships [3-9]

3.1.4 Development of Shapes and Arrangement of Aft Appendages

The development of the configuration of the aft appendages to ensure that induced vibratory forces are minimized is discussed separately, although it is closely related to the development of the afterbody shape. The subjects considered under this heading are as follows:

- Propeller location (fore and aft)
- Shaft strut geometry and shaft strut arm alignment
- Fore and aft clearance between propeller(s) and rudder(s)
- Transverse offset of shaft(s), relative to transverse offset of rudder(s)

Propeller tip clearance and the longitudinal clearance between the skeg (deadwood), struts, or bossings and the propeller(s) is discussed under 3.1.3, above. As a broad guideline, it can be stated that the propeller(s) should be located as far aft as is practicable; this will, in general, tend to maximize propulsive efficiency and minimize the propeller-induced vibratory forces.

The geometry of shaft strut arms must be such as to provide the stiffness necessary to prevent the strut arms from responding to propeller-induced vibratory forces of hydrodynamic origin or those vibratory forces caused by propeller, shaft or engine imbalance. For the design of U.S. Navy ship struts, DDS 161-1 [3-11] applies. DDS 161-1 could also be used for the preliminary design of struts for commercial ships. Strut arms must, of course, be aligned to the flow in order to minimize any adverse effects of these strut arms on the inflow to the propeller. The practice for U.S. Navy ships is to determine the proper alignment of strut arms by means of a model test. Such a test should be carried out with a hull model representing the final hull form, and the final appendages (including the final strut locations as determined by the shipbuilder, if possible), and with a propeller model representing the final propeller design. With respect to the longitudinal clearance between the strut arms and the propeller(s), as noted in 3.1.3, above, a reasonable practice for early stage design is to provide a clearance of at least $0.5 D_p$ between the trailing edge of the strut arms and the centerplane of the propeller (a plane at right angles to the shaft centerline at the propeller center).

The longitudinal clearance between the propeller(s) and the rudder(s) must be selected. While Saunders [3-8] states that clearances abaft the propeller may be less than those ahead of the propeller, the guideline that clearance should not be less than the expanded blade-chord-length at each radius can be used as criterion to determine the allowable clearance between the aft edge of the blade and the leading edge of the rudder. For an example ship (a twin-skeg, T-AO design), the actual clearance was appreciably larger than the clearance required by the "blade-chord-length" guideline (see Figure 3-17). Figure 3-17 shows that another criterion, which requires a minimum clearance of $0.25 D_p$ at $0.7R$, was satisfied for the example ship. It should be noted, that the above two criteria were formulated with reference to "conventional" propeller blade shapes, prior to the increasing use of highly-skewed blades. For "conventional" blades shapes, the clearance will usually tend to remain at the magnitude established at $0.7R$ (as determined by the above criteria), or increase as the radius increases. For the example ship, (Figure 3-17), which featured skewed propeller blades, the blade shape is such that clearance decreases at radii greater than $0.7R$. Nevertheless, the requirement that relates local clearance

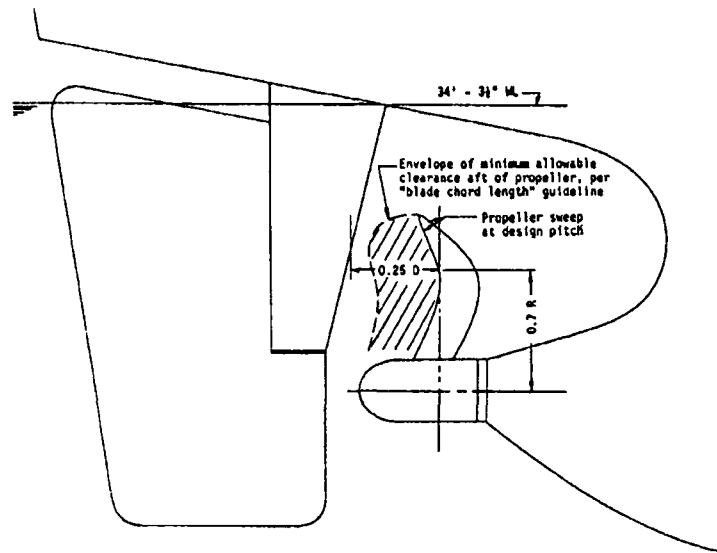

Figure 3-17

Actual and Minimum Required Propeller Blade Clearance for an Example Ship

to local chord length of the blade, which seems to be rational, is satisfied. Both of the guidelines noted above (and illustrated in Figure 3-17) are recommended.

A transverse separation of the rudder(s) and the extended propeller shaft line(s), thereby placing the rudders outside of the shaft hub trailing vortices, is considered to be good practice. This avoids rudder erosion due to the hub vortices and may also reduce vibratory input to the rudders, thereby reducing any tendency for rudder vibration. This separation also enables shaft removal without unshipping the rudders. A reasonable estimate of the transverse separation of shaft centerline and rudder centerline would be as follows: $0.10 D_p$ for ships with fixed-pitch propellers, and $0.125 D_p$ for ships with controllable-pitch propellers.

Numerous considerations affect the design of the rudder(s) and, normally, the strength and structural arrangement requirements will result in rudder shapes and rudder construction such that the rudders will not be likely to vibrate (or transmit vibration to the ship's hull) due to fluctuations in the inflow to the rudder (e.g., due to the fluctuations in the propeller race). However, in some cases it may be necessary to ensure that rudder vibration will not occur. A general approach for avoidance of rudder vibration is as follows:

- Establish the proportions of the rudder in accordance with classification society rules or with the U.S. Navy ship control surface design data sheets, DDS-562-1 and DDS-562-2 [3-12 and 3-13, respectively].
- Estimate the rudder inflow forces and periodicity from appropriate wake and propeller data and from empirical data.
- Estimate the resonant frequency of the rudder, using empirical data.
- Develop the design of the rudder such that resonance with the vibratory inputs will be avoided.

3.1.5 Selection of Propeller Characteristics

As intimated above, if propeller cavitation can be minimized, there is a reasonable likelihood that the hull pressure forces can be minimized; this is due to the fact that propeller cavitation can greatly magnify (by multipliers of 3 to 10, or greater) the hull pressure forces, which would "normally" (i.e., under non-cavitating conditions) result from the passage of the propeller blades through the non-uniform wake field. (These "normal" hull pressure forces can, in turn, be minimized by careful design of the afterbody, propeller blades and afterbody appendages, as discussed herein.) An example of the differences in pressure pulses over the propeller tip, for cavitating and non-cavitating conditions, in this case for a U.S. Navy oiler, is illustrated in Figure 3-18.

It is not the purpose of this document to cover details of propeller design or even details of propeller selection; however, certain general principles apply and these are summarized below. Also, sample data, applicable to a limited range of propellers for certain types of ships, is presented for possible use and to illustrate the approach. General principles, applicable to early design stage selection of basic propeller parameter values for surface, displacement ship, are as follows:

- Large-diameter, low-RPM propellers are, in most cases, more efficient than small-diameter, high-RPM propellers, thereby reducing the required shaft power.

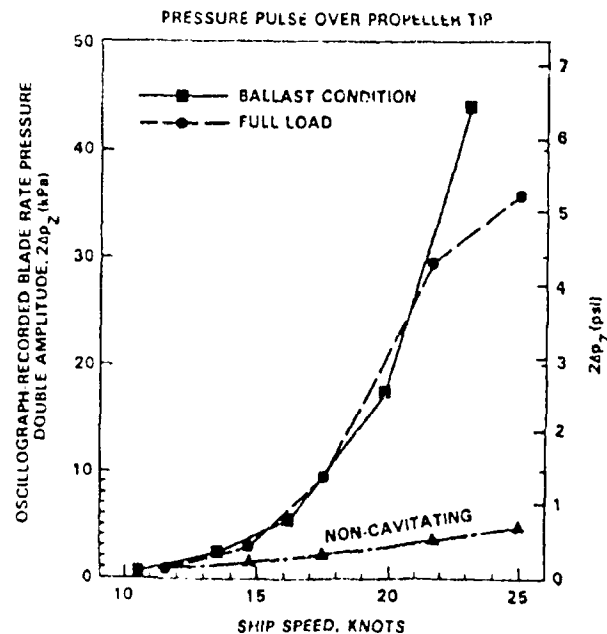

Figure 3-18

Variation of Blade Rate Peak-to-Peak Hull Pressure Over Propeller Tip versus Ship Speed, for U.S. Navy Oiler, Based on Model Tests [3-14]

Ship Vibration Design Guide

- Reducing the propeller full-power RPM usually increases machinery system weight; reducing the propeller full-power RPM may result in reduced fuel consumption.
- Propellers with a low expanded area ratio (E.A.R.) are usually more efficient than propellers with a high E.A.R., thereby reducing the required shaft power.
- Cavitation performance degrades with decreasing E.A.R., for a given diameter and RPM.
- Higher propeller tip speeds degrade tip cavitation performance; hence, a large diameter must normally be complemented with a low RPM to minimize cavitation as well as to maximize the propulsive efficiency.
- As noted above, the provision of adequate propeller tip clearance can help to reduce the risk of propeller-induced hull vibration. In turn, the requirement to provide adequate tip clearance can affect the selection of D_p , especially if the propeller tips are constrained to be above the ship's baseline or not to extend below a specified draft.
- The number of propeller blades is usually not selected during the very early stages of design; however, this selection should be made as a result of a preliminary vibration analysis of the hull/machinery system and this analysis should be carried out as soon as is feasible. In selecting the number of blades, the blade arrangement on the hub and the blade root structure must also be considered, particularly in the case of controllable-pitch propellers.

For early design stage estimates of propeller thrust, torque and efficiency, the appropriate Wageningen B Series data may be used.

As indicated above, the basic propeller design parameter values to be selected are the diameter (D_p) and the blade area ratio (e.g., the expanded area ratio, E.A.R.), the RPM and the number of blades. Sufficient blade area (i.e., sufficient D_p and E.A.R. values) should be provided to yield values of thrust-loading, which result in acceptable cavitation performance. The Burrill Cavitation Diagram, Figure 3-19, may be used as an aid in making this determination. The data included on the Burrill Cavitation Diagram is based on tests of propellers designed prior to 1943. Simple comparisons with the Burrill data do not take into account the cavitation performance that is attainable with contemporary propeller blade designs. The Burrill diagram can, however, be used for a preliminary cavitation performance assessment during early stages of design. Thus, if the computed (τ, σ_v) data point corresponding to the selected propeller loading condition (e.g. the full power, full load condition) for the new ship design falls under the appropriate "limit line" on the Burrill Diagram, the cavitation performance of the eventual propeller(s) should be acceptable. In addition, the plots provided in Figures 3-20 and 3-21 may be of use in selecting values of D_p and RPM, based on the suggested limits for cavitation number, as a function of thrust-loading coefficient; however, as pointed out by Wilson [3-15],

Excitation of Vibratory Forces

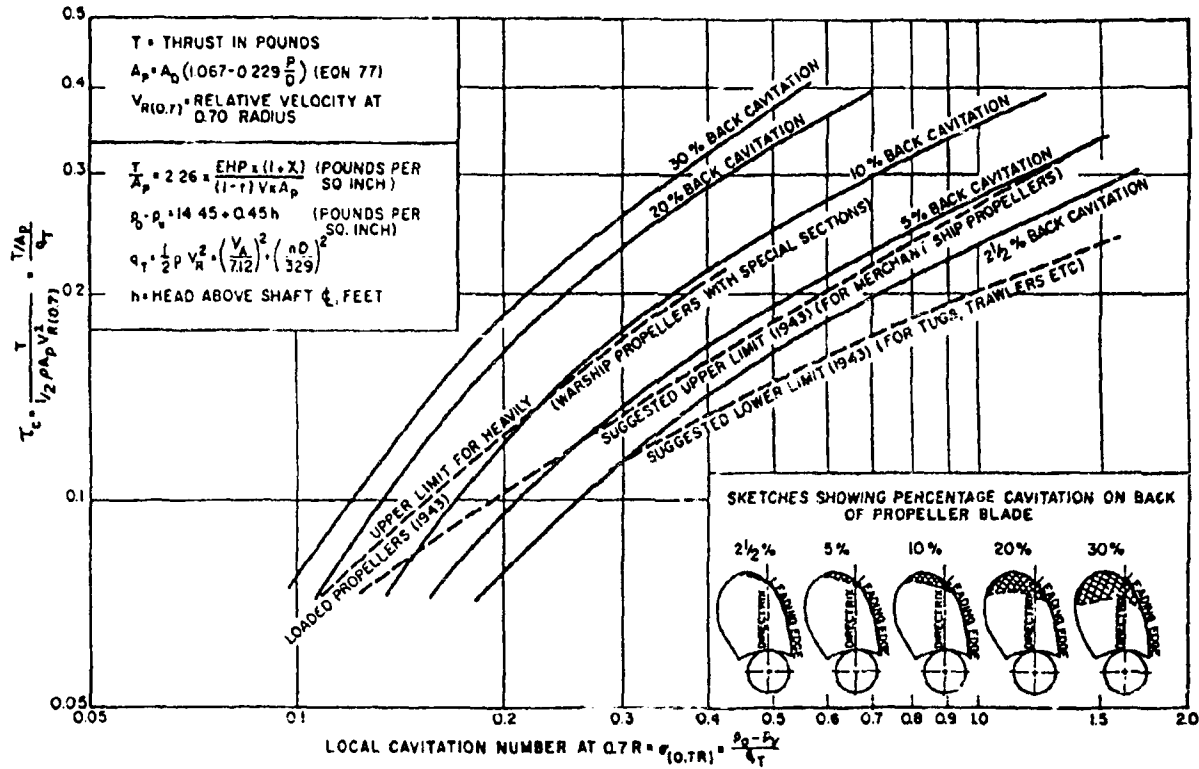

Figure 3-19
Burrill Cavitation Diagram [3-9]

single-screw ships with vibration problems (noted in Figure 3-20) all had cavitation numbers that fell below the suggested cavitation number limit and no data points are shown for the twin-screw ships. Of course, the selection of D_p , E.A.R. and RPM values is also governed by propulsive efficiency considerations and normal machinery design considerations (propeller location, arrangement and tip clearance, weight of machinery plus fuel, limits on propeller RPM due to engine and reduction gear restrictions, etc.).

The number of propeller blades should be selected to keep the propeller forces and moments within acceptable limits and also to avoid development of blade-rate fluctuations of thrust and torque at frequencies close to natural frequencies (through the 5th mode) of the hull and of the propulsion system, respectively. The information in Figure 3-22 can be used as initial, very general guidance for selecting the number of blades, with respect to the range of alternating thrust values and shaft bending moment variations that can be anticipated, for "conventional," single-screw ships having propellers with four, five and six blades. The plot in Figure 3-23 shows some disparity between calculated and experimentally determined values of excitation force, for one set of four, five, and six-bladed propellers. Additional data, for both single-screw and twin-screw ships, should be assembled in order to provide the needed guidance for selection of the number of propeller blades.

Ship Vibration Design Guide

$$\sigma_n = (p_0 - p_v) / (0.5 \rho n^2 D^2)$$

$$C_T = T / (0.5 \rho V_A^2 A_0)$$

$$A_0 = \pi D^2 / 4 = \text{prop disk area}$$

n = prop revolutions per unit of time

p_0 = static pressure at shaft C.L.

p_v = vapor pressure of water

V_A = flow velocity into prop

T = prop thrust

J = prop advance coefficient

ΔJ = increment in J , based on increment in thrust (T) and the slope ($\Delta K_T / \Delta J$)

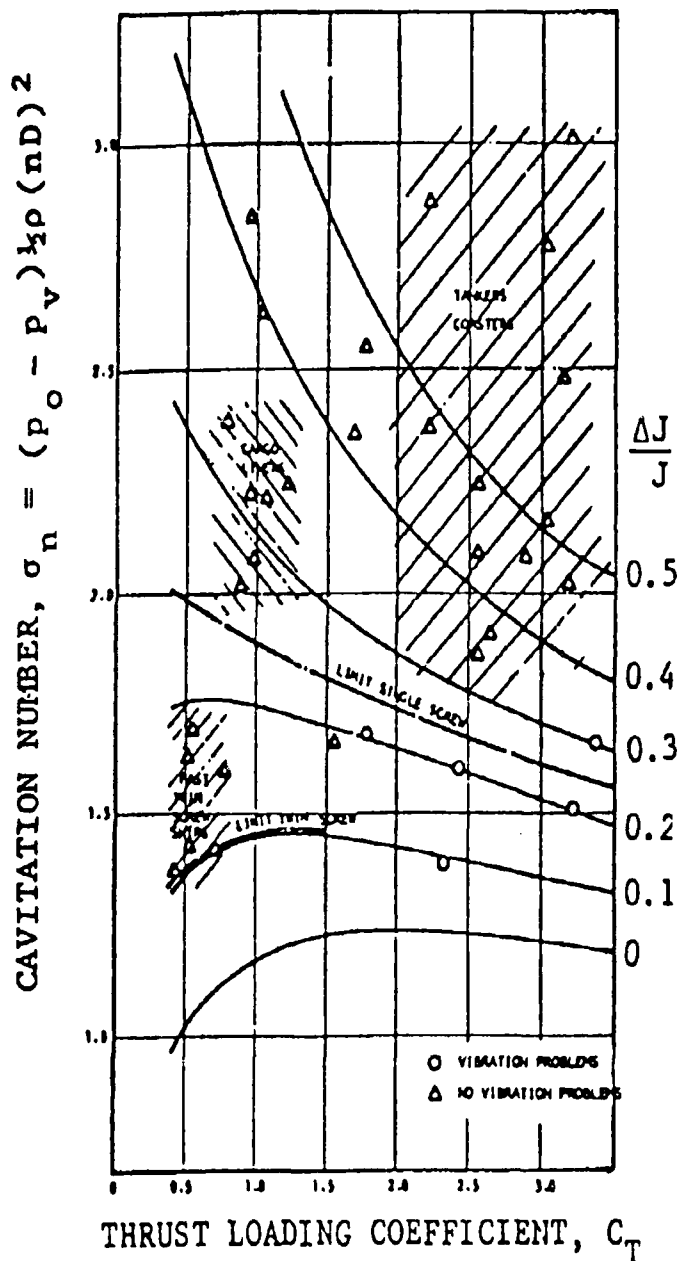

Figure 3-20

Vibration Problem Areas Identified in a σ_n versus C_T Diagram [3-15, 3-16]

$$\sigma_{VA} = (p_0 - p_v) / (0.5 \rho V_A^2)$$

$$C_T = T / (0.5 \rho V_A^2 A_0)$$

$$A_0 = \pi D^2 / 4 = \text{prop disk area}$$

p_0 = static pressure at shaft C.L.

p_v = vapor pressure of water

V_A = flow velocity into prop

T = prop thrust

J = prop advance coefficient

ΔJ = increment in J , based on increment in thrust (T) and the slope ($\Delta K_T / \Delta J$)

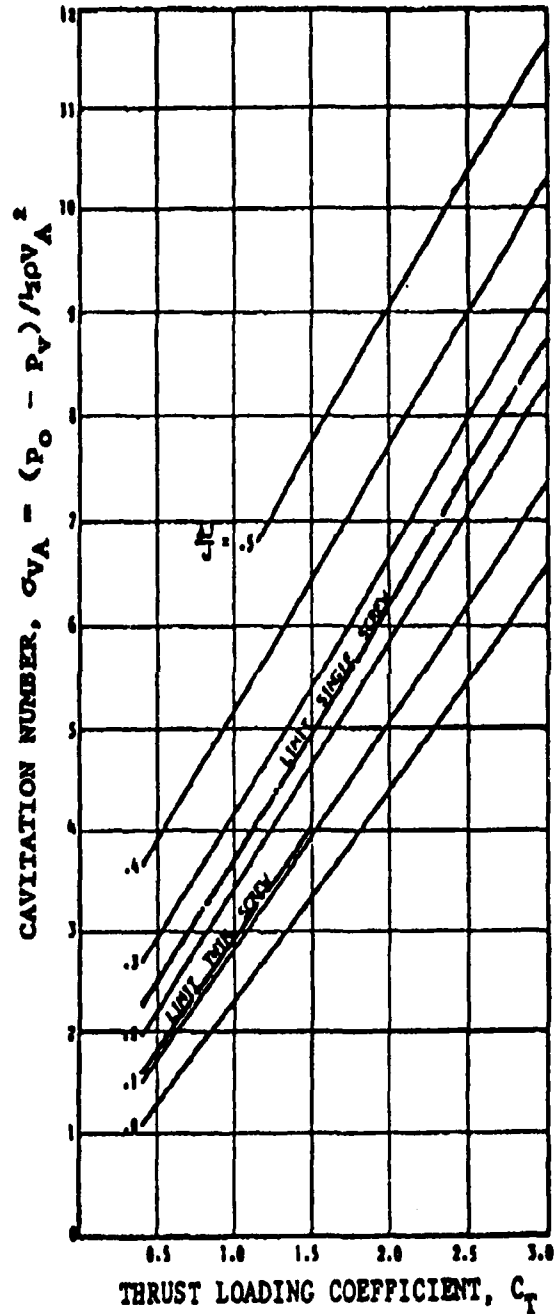

Figure 3-21

Vibration Problem Areas Identified in a σ_{VA} versus C_T Diagram [3-15, 3-16]

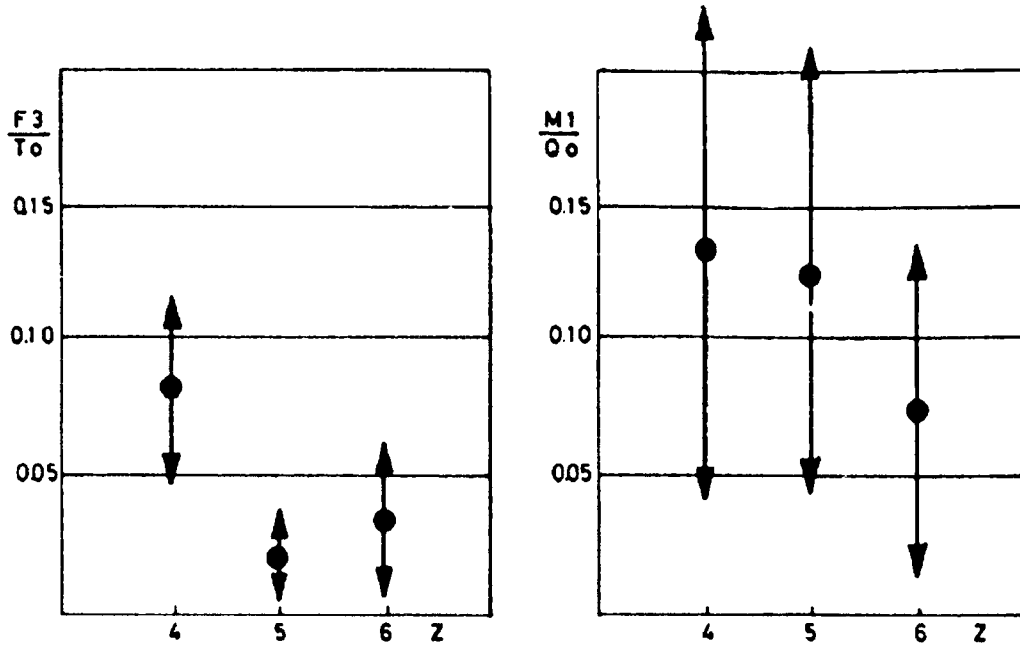

Figure 3-22

Normalized Thrust (F3) and Horizontal Bending Moment (M1) Variations at Blade Frequency Shown as Mean Values and Standard Deviations. Four-, Five-, and Six-Bladed Propellers Fitted on Conventional Single-Screw Ships [3-17]

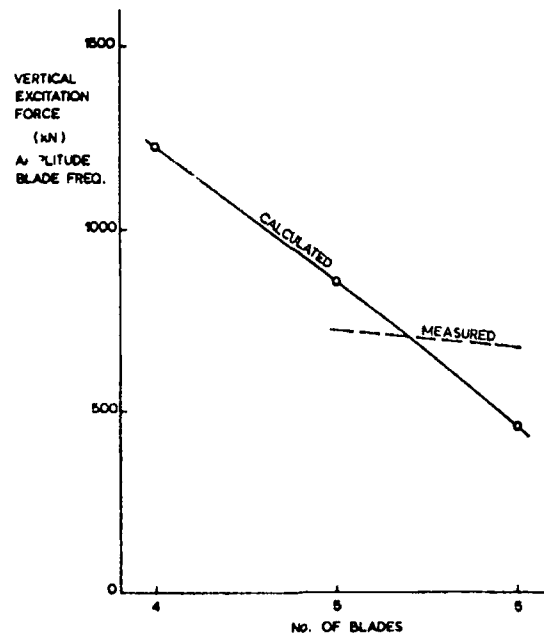

Figure 3-23

Effect of Number of Propeller Blades on Vertical Excitation Force [3-18]

As noted previously, the recommended approach to development of a ship design having minimized propeller-induced vibratory forces is to first select the propeller characteristics such that the cavitation will be minimized. Guidelines to aid in the selection of the characteristics of the propellers for a particular range of ship designs [large, single-screw ships with conventional sterns, Hogner-type (or, bulbous) sterns, and open sterns] were developed by Atlas, et al. [3-19], and are presented below. This detailed material, although applicable to a very limited range of ship designs, is included herein as a significant example.

The example "cavitation-minimization" guidelines (reproduced from the report by Atlas [3-19]) make use of a modified Burrill chart. This modified Burrill chart, Figure 3-24, shows relationships between mean blade lift coefficient C_L , and local cavitation number, σ_0 . Six data

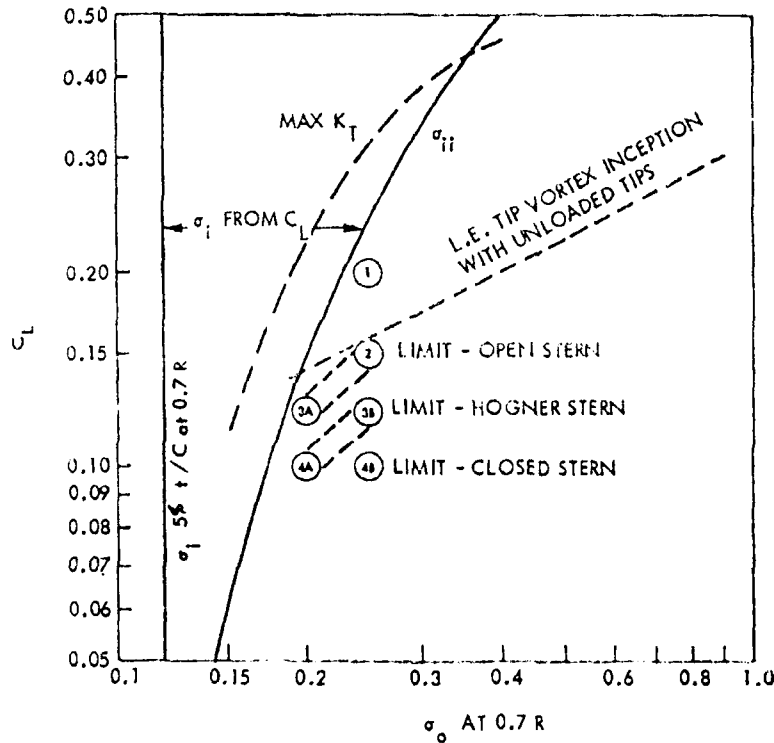

Figure 3-24

Modified Burrill Cavitation Diagram [3-19]

points located on Figure 3-24 indicate estimated maximum acceptable blade loadings, from a cavitation viewpoint (for large single-screw ships). Propellers operating at these conditions will not be cavitation free but will have about three or four percent of the blades covered by cavitation, depending on wake characteristics. The applicability of the six data points is as follows:

- Point 1 reflects an estimate of the limiting condition for a propeller operating in circumferentially uniform flow. This point lies very close to the back bubble boundary and thus will have little tolerance for variations in inflow conditions. Some tip vortex cavitation will be present, due to the relatively high design lift coefficient.

Ship Vibration Design Guide

- Points 2 and 3A connect a region judged to be acceptable for hulls with very good wake characteristics, such as hull forms with open sterns where the primary wake non-uniformity comes from the circumferential wake component due to shaft inclination. Points 2 and 3A lie on a line that would represent propellers with the same thrust requirements but operating with different rotation rates. Typically, Point 2 would apply to low speed ships and Point 3A to higher speed ships.
- Points 3B and 4A lie on a line that would represent propellers acceptable for ships with moderate wake characteristics, such as Hogner-type sterns with large propeller clearances (particularly those with large clearances ahead of the blades).
- Point 4B applies to conventional (closed-stern) designs having better than average propeller clearances and relatively fine stern lines.

With the aid of momentum equations, the operating conditions represented by the six above described data points were converted into propeller operating characteristics for a range of thrust loadings (C_{Th}), for the large, single-screw ships being considered. For the purpose of illustration, it has been assumed that the propellers have five blades and a projected area ratio of 0.80. It was found that this area ratio yielded propellers with slightly higher than optimum loading from an efficiency standpoint. Thus, while higher projected area ratios would allow higher loading before reaching the cavitation limit, the efficiency penalty associated with such a high loading would make the designs of little practical interest. The above assumptions must be born in mind when using this set of data.

The resulting propeller operating characteristics are presented in Figures 3-25 through 3-28, where each figure corresponds to the specific mean lift coefficient (C_L) values corresponding with Data Points 1, 2, 3A/3B and 4A/4B, respectively, on Figure 3-24. Included on these curves are: advance coefficient, J ; open water propeller efficiency, η_0 ; pitch diameter ratio, P/D ; propeller thrust coefficient, K_T ; blade area ratio, BAR ; and maximum allowable value of thrust loading coefficient, C_{Th} (as a function of cavitation number based on ship speed, σ_s). These curves thus represent the estimated maximum loading that can be applied to a propeller of given diameter at a given ship speed.

The maximum allowable thrust loading coefficient, C_{Th} , for each operating condition can be related to the cavitation number based on ship speed, σ_s , as follows:

$$\frac{\sigma_0}{A \times C_L} = \left(\frac{A_p}{A_0} \right) \left(\frac{\sigma_s}{A \times C_{Th}} \right)$$

where σ_0 is the local section operating cavitation number, A is a section camber distribution constant, σ_s is the cavitation number based on ship speed, and A_p/A_0 is the projected area ratio of the propeller blades. This relationship yields the following:

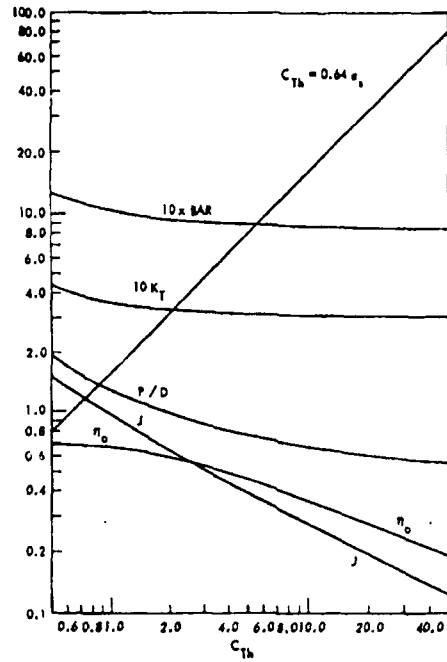

Figure 3-25

Propeller Characteristics for Maximum Loading with Uniform Inflow (Case 1):
 Maximum $C_{Th} = 0.64 \sigma_s$, 5 Blades, $PAR = 0.8$, Design $C_L = 0.200$ [3-19]

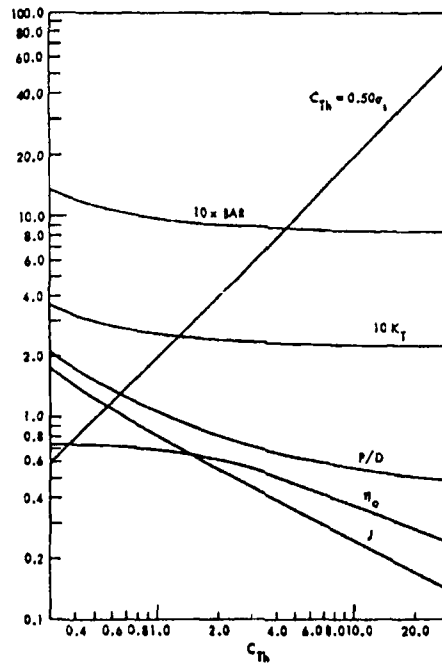

Figure 3-26

Propeller Characteristics for Maximum Loading with Open Stern-Low Speed (Case 2):
 Maximum $C_{Th} = 0.50 \sigma_s$, 5 Blades, $PAR = 0.8$, Design $C_L = 0.150$ [3-19]

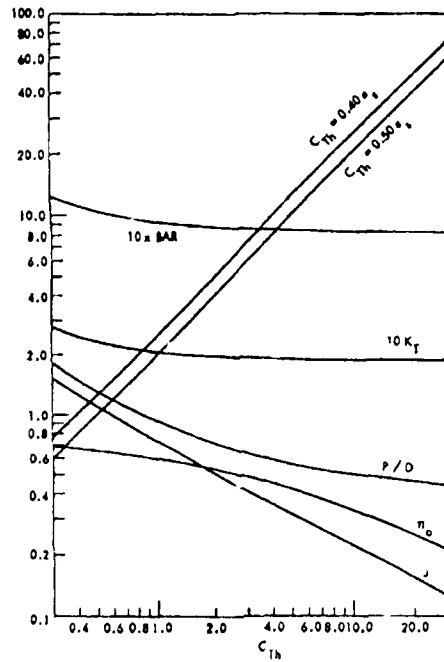

Figure 3-27

Propeller Characteristics for Maximum Loading with Open Stern-High Speed (Case 3A):
 Maximum $C_{Th} = 0.50 \sigma_S$; and with Hogner Stern-Low Speed (Case 3B):
 Maximum $C_{Th} = 0.40 \sigma_S$; 5 Blades, $PAR = 0.8$, Design $C_L = 0.125$ [3-19]

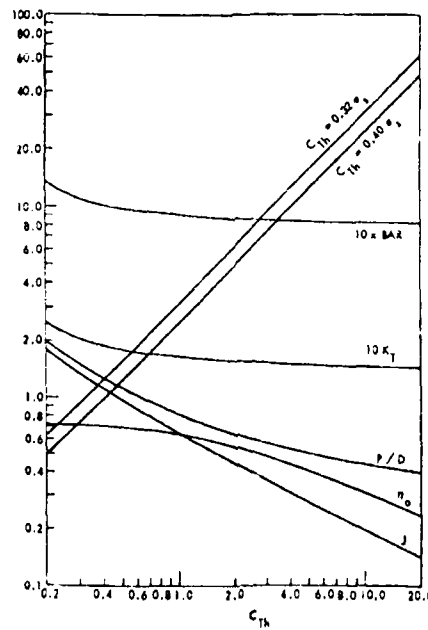

Figure 3-28

Propeller Characteristics for Maximum Loading w/ Hogner Stern-High Speed (Case 4A):
 Maximum $C_{Th} = 0.40 \sigma_S$; and with Conventional Stern-Low Speed (Case 4B):
 Maximum $C_{Th} = 0.32 \sigma_S$; 5 Blades, $PAR = 0.8$, Design $C_L = 0.100$ [3-19]

For uniform wake,	Max. $C_{Th} = 0.64 \sigma_s$
For open sterns,	Max. $C_{Th} = 0.50 \sigma_s$
For Hogner-type sterns,	Max. $C_{Th} = 0.40 \sigma_s$
For conventional sterns,	Max. $C_{Th} = 0.32 \sigma_s$

For the large, single-screw ships being considered, the influence of wake non-uniformity is to reduce the allowable propeller loading such that a good conventional stern will limit the acceptable loading to about half that which is acceptable in a uniform wake.

The information presented on Figures 3-25 through 3-28 can be used to determine the maximum power (for the large, single-screw ships being considered), which can be absorbed by a propeller of a given diameter under specified operating conditions. As an example, suppose it is desired to determine the maximum power that could be absorbed by a 30 foot diameter propeller at 32 knots, with a Hogner-type stern. The wake fraction is estimated to be about 0.20 and the propeller submergence to the 0.7 radius is estimated to be about 24 feet, for this ship. The resulting cavitation number, σ_s , is 1.95. For this case, the maximum C_{Th} value is $0.45 \sigma_s$, or 0.78. Using Figure 3-28, since this is a high speed ship, we get the following data:

Advance coefficient, $J = 0.74$, which corresponds to 117 RPM

Propeller efficiency, $\eta_0 = 0.66$, which corresponds to 131,000 DHP

Pitch diameter ratio = 0.90

Thrust coefficient, $K_T = 0.17$

Blade area ratio, $BAR = 0.93$

For this example, a series of plots have been prepared, which show the limiting power levels for a Hogner-type stern ($C_{Th} = 0.4 \sigma_s$), for a range of propeller diameters from 20 to 50 feet and for a range of design speeds from 16 to 32 knots. In preparing these figures, the following parameter values were assumed:

Ship speed in knots (V_R)	16	24	32
Wake fraction (W)	0.40	0.30	0.20
Thrust deduction fraction (t)	0.20	0.20	0.20
Relative rotative efficiency (η_R)	1.0	1.0	1.0
Propeller submergence to 0.7 radius	$1.6 D_p$	$1.2 D_p$	$0.80 D_p$

For this example, Figures 3-29 through 3-31 show the variation of propeller efficiency (η_0) with diameter and delivered horsepower (DHP) at 16, 24, and 32 knots, respectively. Constant efficiency lines on these figures correspond to a constant propeller loading in terms of C_{Th} .

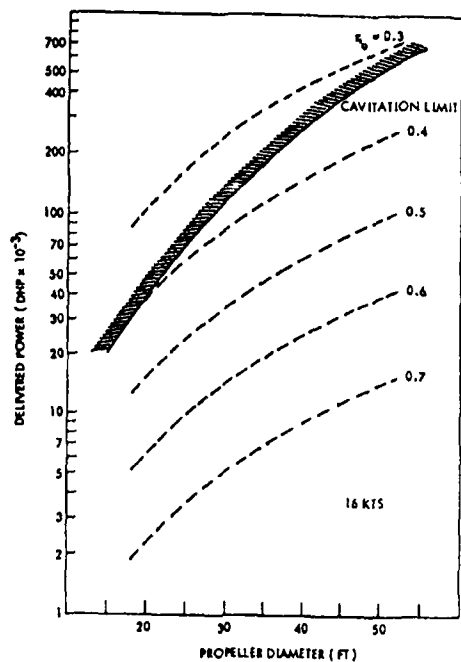

Figure 3-29

Variation of Propeller Efficiency (η_0) with Diameter and Delivered Power at 16 Knots;
 $w = 0.40$, $t = 0.20$, Submergence to $0.7R = 1.6$ Diameter [3-19]

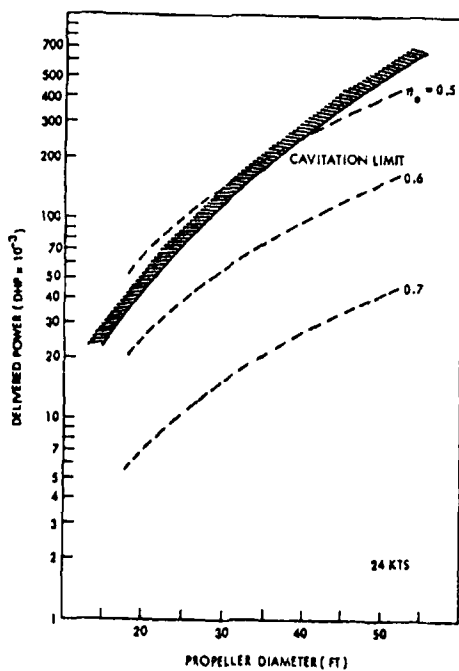

Figure 3-30

Variation of Propeller Efficiency (η_0) with Diameter and Delivered Power at 24 Knots;
 $w = 0.30$, $t = 0.20$, Submergence to $0.7R = 1.2$ Diameter [3-19]

Excitation of Vibratory Forces

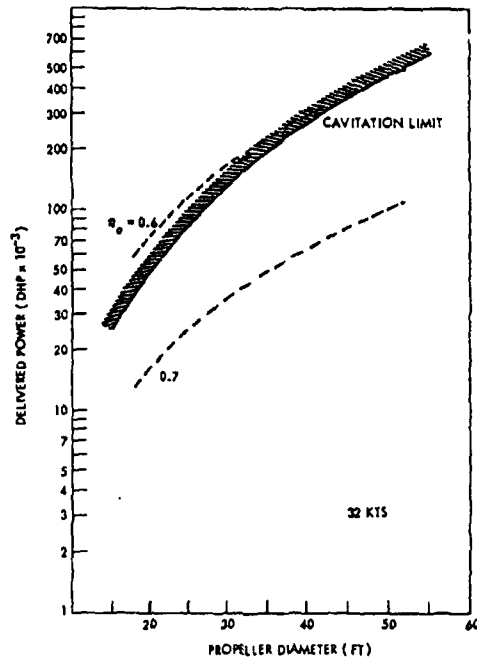

Figure 3-31

Variation of Propeller Efficiency (η_0) with Diameter and Delivered Power at 32 Knots;
 $w = 0.20$, $t = 0.20$, Submergence to $0.7R = 0.8$ Diameter [3-19]

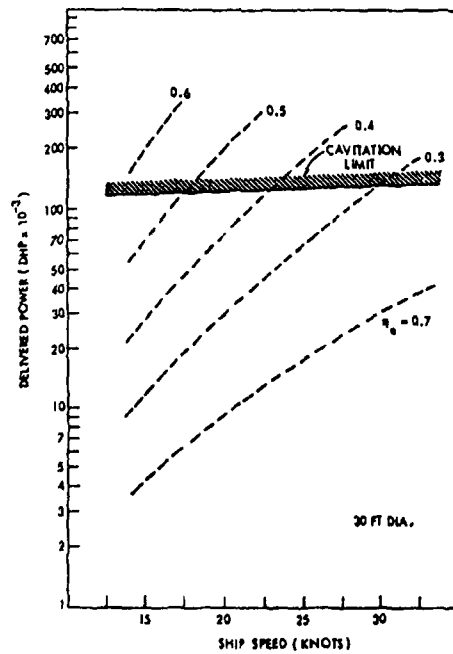

Figure 3-32

Variation of Propeller Efficiency (η_0) with Ship Speed
 and Power for a 30 foot Diameter Propeller [3-19]

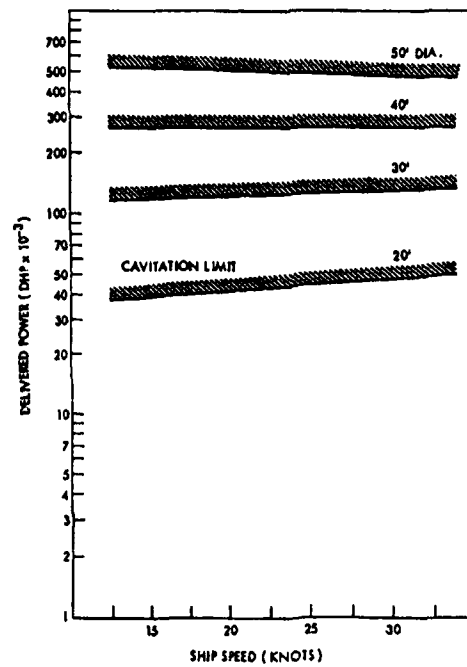

Figure 3-33

Variation of Cavitation-Limited Delivered Power (DHP) with Ship Speed, for Various Propeller Diameters [3-19]

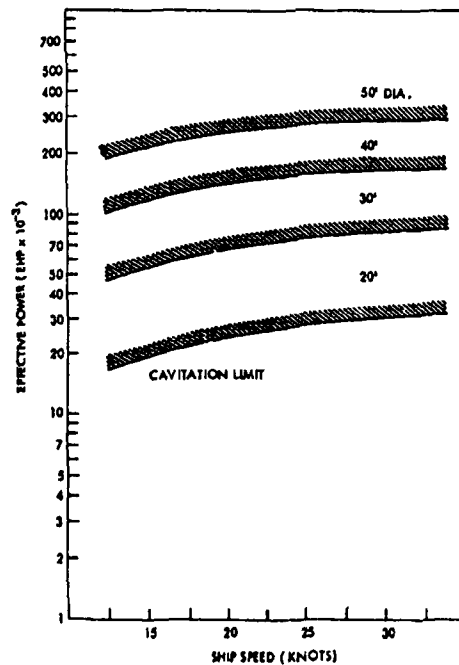

Figure 3-34

Variation of Cavitation-Limited Effective Power (EHP) with Ship Speed, for Various Propeller Diameters [3-19]

Note that the cavitation limit permits higher loadings, corresponding to lower efficiency lines, for larger propellers. This is due to the increased submergence, and corresponding cavitation number, for the larger propellers. Figure 3-32 is a cross plot of Figures 3-29 through 3-31, for the 30 foot diameter propeller used in the example. The low efficiencies at the cavitation limit for low speeds reflect the high thrust loadings permitted at low speeds. Thus, efficiency rather than cavitation, would probably be the limiting consideration at low design speeds. Figure 3-33 shows the cavitation-limited power (*DHP*) as a function of ship speed, for various propeller diameters. Note that the power limit is nearly independent of speed. (The 30 foot diameter limit line is the same as shown on Figure 3-32.) Figure 3-34 is similar to Figure 3-33, but it gives the *EHP* limit instead of the *DHP* limit. The lower *EHP* values at low ship speeds reflects the lower efficiency associated with the higher thrust loadings possible at low speeds.

As noted previously, the above guidance material and the example apply to large, single-screw ships. Similar guidelines could be developed for other sizes and types of ships, and used in selecting the basic propeller characteristics during early stages of design, as an integral part of the process of designing to minimize vibratory forces and moments.

In addition to selection of the gross characteristics, the details of the propeller blade design must eventually also be developed to minimize propeller-induced vibratory forces; this includes development of the blade area distribution, contour, pitch distribution, section shapes, rake, skew, etc. Development of the detailed blade design is beyond the scope of this report; however, it should be noted that blade skew has been found to be particularly useful for minimizing hull pressure amplitudes, assuming that the other characteristics are carefully selected. An example of the effect of blade skew on hull pressure amplitude for a particular hull/propeller configuration, is presented in Figure 3-35.

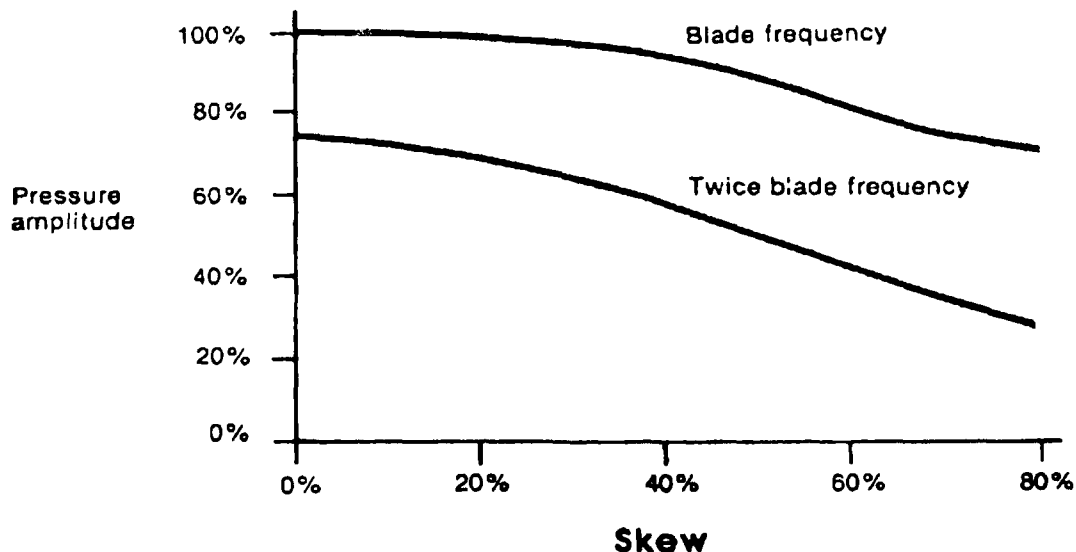

Figure 3-35
Effect of Blade Skew on Hull Pressure

Numerous references applicable to the details of propeller design are available. For commercial ship designs, the information presented in SNAME and RINA publications and in "International Shipbuilding Progress" and other periodicals, should be utilized. For U.S. Naval ship designs, the propeller design practices developed by NAVSEA and DTRC would apply.

3.2 Early Design Stage Estimates of Propeller-Induced Vibratory Forces and Moments

3.2.1 Approach

As noted previously, the hull shape details, the design of the appendages and the propeller design can be refined, with respect to minimization of vibratory forces, during the later stages of design since the required detailed ship design information and results of appropriate model tests will be available at that time. During the early stages of design, when only a preliminary lines drawing (or body plan), an appendage sketch and minimal definition of the propeller(s) may exist, vibratory force and moment estimates can be made by interpolation/extrapolation of applicable data previously calculated for generally similar ships.

Fundamental to this approach is the fact that propeller-induced alternating thrust (\tilde{T}) and alternating torque (\tilde{Q}) values have been found to vary roughly in proportion to the variation in the value of propeller advance coefficient (J), for generally similar hull/appendage/propeller configurations, with the hull forms having approximately equal values of block coefficient (C_B).

The first step in this estimating process is to assemble the calculated values of \tilde{T} and \tilde{Q} and the corresponding values of alternating horizontal bearing force (\tilde{F}_H), alternating vertical bearing force (\tilde{F}_V), mean thrust (\bar{T}) and mean torque (\bar{Q}), all at design full-power speed and all on a per shaft basis, plus the pertinent hull form and propulsion data for the similar ships. A sample of this type of assembled data is presented in Table 3-3. The material in Table 3-3 was utilized in the 1982 review of a proposed hull/propeller configuration for the T-AO 187 Baseline. This material and the material presented in Table 3-4, which relates to the vibratory force measurements and analyses carried out for three different LNG ship hull/propeller configurations (see Figures 3-3, 3-4, and 3-5), represented readily available data suitable for use in early design stage vibratory force estimates; hence, this material is referred to in this and other chapters of this publication. As the initial edition of this publication was nearing completion, some additional unsteady thrust and unsteady torque data, including the associated data source references, was supplied by the American Bureau of Shipping. This data is included in Table 3-5. It is important to note, that to facilitate the development of early design stage estimates of propeller induced vibratory forces, considerably more empirical data (of the type represented in Tables 3-3, 3-4, and 3-5) must be assembled.

The next step is to plot as functions of J the values of \tilde{T} , \tilde{F}_H , and \tilde{F}_V , all expressed as percentages of \bar{T} , and of \tilde{Q} expressed as a percentage of \bar{Q} . Figure 3-36, which is a plot of the data presented in Table 3-3, is a sample of this type of plot.

Table 3-3 Characteristics of Generally Similar Twin-Screw Ships and Associated Vibratory Force Data

	Type I	Type II	Type III	Type IV	DD 963
z	6	5	4	5	5
V_s	33.4	22.00	34.00	29.00	Omitted
L	520.00	548.00	383.00	540.00	530.00
B	53.83	82.10	40.50	57.0	54.00
T	18.57	21.58	13.00	20.30	18.00 Des.
Trim by Stern	1.00	2.17	E.K.	E.K.	E.K.
Δ , Tons	7,000	17,000	3,051	9,217	7,500
L/B	9.70	6.67	9.45	9.50	9.62
C_B	0.469	0.589	0.529	0.514	0.480
SHP per Shaft	40,000	33,700	30,475	23,835	40,000
EHP/SHP	0.708	0.560	0.63	0.664	0.69
EHP	28,150	18,872	19,200	15,815	27,600
$1 - W$	1.023	0.905	0.983	0.970	0.980
$1 - t$	0.955	0.800	0.955	0.916	0.960
RPM	176.00	251.00	345.0	224.8	
D	18.33	12.50	12.00	15.00	17.00
\bar{T}	268,100	160,000	192,000	195,000	284,000
\bar{Q}	1,131,600	350,000	465,000	560,000	1,236,400
V/\bar{C}	1.47	0.942	1.74	1.24	1.43
\bar{T} in % of \bar{T}	± 1.70	± 0.98			± 1.79
\bar{Q} in % of \bar{Q}	± 1.30	± 0.46			± 1.26
F_H in % of \bar{T}	± 1.50	± 0.32			± 1.43
F_V in % of \bar{T}	± 1.00	± 0.42			± 1.00
J	1.08	0.839	0.815	0.845	1.13

Preliminary estimates of the following information must be available for the new ship design:

- Propeller diameter (D_P), or a range of D_P values
- Design full-power propeller rate of rotation (n), or a range of values of n .
- EHP, SHP, $1-t$ and $1-W_T$ values at the (estimated) design full-power speed.

Using this information, values of J , \bar{T} , and \bar{Q} are computed as follows:

$$J = \frac{V_s (1 - W_T)}{n D_P}$$

Ship Vibration Design Guide

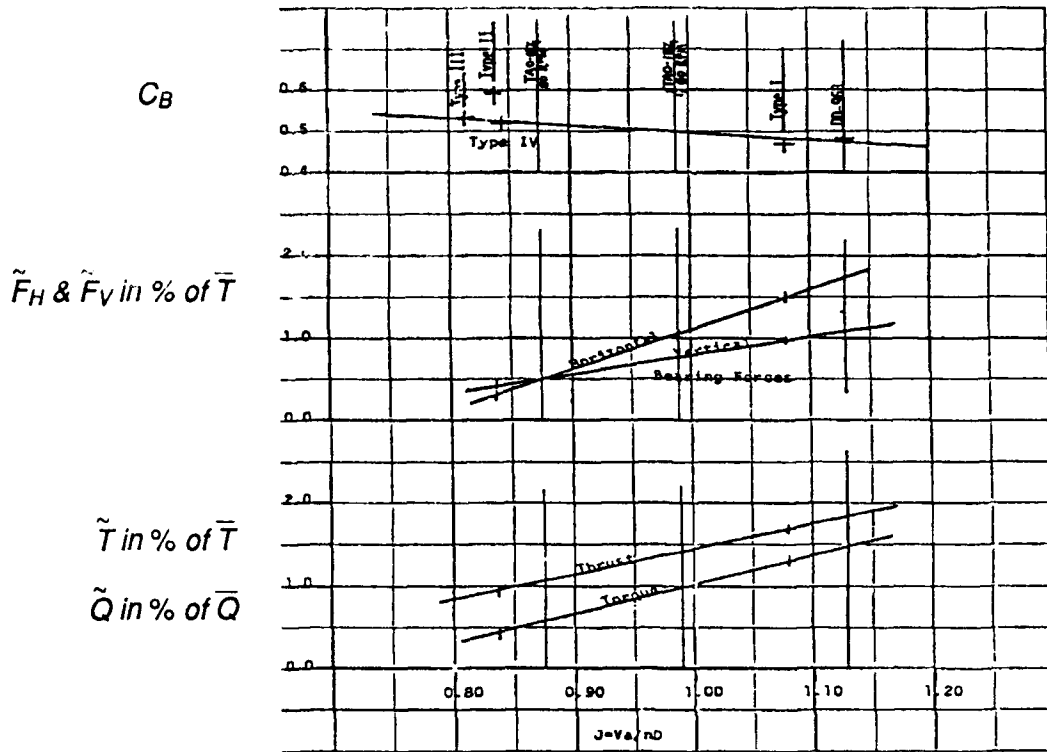

Figure 3-36

Calculated Propeller Forces for Generally Similar Twin-Screw Ships

Table 3-4 Vibratory Force Data for Large, Single-Screw LNG Ship Design

125,000 CM LNG Ships with 5-Bladed Propeller Results of Calculations of Propeller Forces Based on NSMB Data*			
	Model 4141	Model 4147	Model 4148
V_s , kts	20.0	19.0	20.0
SHP_m	43,000	34,400	41,600
D , ft	26.64	25.0	24.5
\bar{T} Thrust, lbs	635,800	472,900	451,600
\tilde{T} , \pm lbs	39,760	31,820	17,520
$\tilde{T} / \bar{T} \pm \%$	6.25	6.75	3.89
\bar{Q} Torque, ft-lbs	2,370,000	1,754,000	2,053,000
$\tilde{Q} \pm$ ft-lbs	97,470	88,780	56,660
$\tilde{Q} / \bar{Q}, \pm \%$	4.10	5.05	2.74
\tilde{F}_H Bearing Force, lbs	6,750	3,900	4,950
$\tilde{F}_H / \bar{T}, \pm \%$	1.06	0.82	1.11
\tilde{F}_V Bearing Force, lbs	3,190	1,660	2,134
$\tilde{F}_V / \bar{T}, \pm \%$	0.50	0.35	0.47

*Applicable to hull/propeller configurations depicted in Figures 3-3, 3-4, and 3-5

Excitation of Vibratory Forces

where V_s is the estimated design full-power speed. Note that J is a non-dimensional quality; hence the units used to express the value of each quantity must be consistent.

$$\bar{T} = \frac{550 \text{ EHP/shaft}}{V_s(1-t)}$$

where \bar{T} is in pounds, and V_s is the ship speed in ft/sec.

$$\bar{Q} = \frac{550 \text{ SHP/shaft}}{2\pi n}$$

where \bar{Q} is in ft-lbs, and n is in revolutions per second.

Table 3-5 Normalized Values of Unsteady Thrust and Unsteady Torque
for a Number of Ships

Unsteady Thrust (In % of Steady Thrust)				
Ship	Blade Frequency	4-Bladed Propeller	5-Bladed Propeller	6-Bladed Propeller
20 Ships Measured [3-20]	Once	4.7-11.5	1.4-2.7	1.2-6.0
	Twice	1.7-2.6	1.4-2.0	1.0-5.0
Oil Carrier Calculated [3-21]	Once		1.4-9.5*	
	Twice		1.3-8.7*	
Tanker Calculated [3-22]	Once		2.0	
	Twice			
Bulk Carrier Measured [3-23]	Once	9.24	1.6	
	Twice	0.9	0.95	
Containership Measured [3-24]	Once	5.0		
	Twice	0.76		
*The large value is for the fully loaded condition and the small value is for the ballast condition.				
Unsteady Torque (In % of Steady Torque)				
Ship	Blade Frequency	4-Bladed Propeller	5-Bladed Propeller	6-Bladed Propeller
20 Ships Measured [3-20]	Once	4.0-9.0	1.0-2.0	1.0-5.0
	Twice	0.5-2.8	0.7-2.1	0.8-1.2
Oil Carrier Calculated [3-21]	Once		0.7-5.9**	
	Twice		0.7	
Bulk Carrier Measured [3-23]	Once	5.0	1.0	
	Twice	0.5	0.55	
Containership Measured [3-24]	Once	5.0		
	Twice	0.2		
**The large value is for the fully loaded condition and the small value is for the ballast condition				

Ship Vibration Design Guide

For early design stage estimates, it may be that a range of propeller diameters and rates of rotation are under consideration; for such a situation, a range of J values and \bar{Q} values, corresponding to two or more (D_p, n) combinations, would be computed. The next step is to enter the data plot (similar to that in Figure 3-36) at the computed J value(s) and determine estimated values of T , F_H and F_V , as percentages of T and estimated value(s) of \bar{Q} as (a) percentage(s) of \bar{Q} .

Comparisons of ship vibrations, as measured during proper trials, and as estimated using the early design stage vibratory force and moment estimating method discussed above, have indicated that a modulation factor of two should be applied to the calculated values of F_H and F_V and that an alternating hull pressure force component should be included to properly estimate the total vertical force on the hull, from each propeller. In this regard, it has been determined that it is reasonable to assume that the alternating hull pressure force would be equal to and in phase with the alternating vertical bearing force (F_V), for the case where little or no propeller cavitation exists. (Excessive propeller cavitation can greatly increase the hull pressure forces, and must be separately considered; the approach recommended herein is to size the propeller such that excessive cavitation will not occur.) Since there will normally be little effect of the hull pressure force exhibited in the horizontal plane, it is not necessary for these early design stage estimates, to augment F_H with an alternating hull pressure factor.

For early design stage estimates of propeller induced forces for twin-screw ships, the forces generated by the two shafts are assumed to be equal to and in phase with each other; therefore, the force per shaft is multiplied by another factor of 2.0 to provide the estimated total force on the hull. A summary of the above described relationships for early design stage, propeller-induced vibratory force and moment estimates is given below.

Alternating Hull Forces

Single-Screw Ship, Horizontal Force: Calc'd $\tilde{F}_H \times 2$ (modulation factor)

Single-Screw Ship, Vertical Force: Calc'd $\tilde{F}_V \times 2$ (modulation factor) $\times 2$ (hull pressure factor)

Twin-Screw Ship, Horizontal Force per Shaft: Calc'd $\tilde{F}_H \times 2$ (modulation factor)

Twin-Screw Ship, Vertical Force per Shaft: Calc'd $\tilde{F}_V \times 2$ (modulation factor) $\times 2$ (hull pressure factor)

Twin-Screw Ship, Total Horizontal Force: Calc'd $\tilde{F}_H \times 2$ (modulation factor) $\times 2$ (two-shafts-in-phase factor)

Twin-Screw Ship, Total Vertical Force: Calc'd $\tilde{F}_V \times 2$ (modulation factor) $\times 2$ (hull pressure factor) $\times 2$ (two-shafts-in-phase factor)

Alternating Shaft Forces and Moments

Single-Screw Longitudinal Force: Calc'd \tilde{T}

Single-Screw Torsional Moment: Calc'd \tilde{Q}

Twin-Screw Longitudinal Force: Calc'd \tilde{T} (for each shaft)

Twin-Screw Torsional Moment: Calc'd \tilde{Q} (for each shaft)

3.2.2 Example

An example of an early design stage estimate of propeller-induced vibratory forces and moments is presented in Appendix 3-A. This appendix is a copy of material developed by NKF, Inc. for the T-AO 187 Baseline Review, May, 1982.

3.3 Guidelines for Minimization of Propulsion System Induced Vibratory Forces and Moments

The primary causes of propulsion system induced vibratory forces and moments are as follows:

- Engine imbalance
- Propulsion shafting imbalance
- Propulsion shafting misalignment
- Propeller imbalance
- Propeller blade pitch differences

Engine imbalance is most apt to occur in ships propelled by slow-speed, direct drive diesels or medium-speed diesels with direct or geared drives; however, all rotating machinery, including propulsion turbines, must satisfy dynamic balancing requirements. Criteria for the dynamic balance of turbines, gears, shafting and propellers are given in Chapter Two, under Section 2.4. In order to minimize vibratory forces and moments due to diesel engine imbalance, the following guidelines are given:

- Select engines known to exhibit minimal imbalance.
- Avoid engine operating speeds that coincide with first and second order vibration.
- Select a fore and aft location of the engine(s) such that, knowing the normal modal patterns of the hull vibratory response, magnification of the response can be avoided.
- Design engine foundations to avoid dynamic response.
- Possibly, utilize fixed or fractionally-damped engine bracing.
- As a last resort, consider the use of dynamic absorbers.

Ship Vibration Design Guide

More detailed information on diesel engine vibratory forces and moments is given in Chapter Five.

The minimization of vibratory forces and moments due to propeller blade pitch differences can be accomplished by application of appropriate criteria and standards (e.g., the criteria and standards of the U.S. Navy, and the criteria and standards of the several classification societies).

3.4 General Comments and Recommendations

The Ship Vibration Design Guide is intended to be a first step in the establishment of a practical approach to the control of ship vibration. As such, this chapter is a first step in the establishment of a practical approach to the development of estimates of the vibratory forces.

It is considered that the approach discussed in this chapter (i.e., selection of basic propeller characteristics to avoid obvious resonance and hull pressure problems, selection of basic hull characteristics and development of the hull/appendage/propeller configuration to minimize vibratory forces and moments, all in accordance with Preliminary Design-type guidelines presented herein) is appropriate; however, the nature of this subject is such that considerably more can be done to enhance the usefulness of this approach. Selected recommendations for effort that would appear to be immediately useful for augmenting the approach are as follows:

- Assemble additional guidance material in the areas of afterbody design, propeller clearances and appendage arrangements (new material appears frequently in open U.S. and foreign magazines and technical papers); integrate this material with material presented in this initial document.
- Prepare material for selection of propeller characteristics, which is similar to that presented herein for large, single-screw ships, but is applicable to an appropriately wide range of single- and twin-screw ships.
- Assemble additional sets of ships characteristics and associated vibratory force data, similar to that presented in Tables 3-3, 3-4 and 3-5 for as wide a range of ship size, propulsive power, and hull/appendage/propeller configurations as possible. This material should, if possible, apply to ships with good vibration characteristics, as well as those with poor vibration characteristics (thereby allowing the designer to avoid any hull/appendage/propeller characteristics that obviously lead to vibration problems). Such material would constitute the real design data, which is needed during early stages of ship design.

REFERENCES

- 3-1 Ward, G., "The Application of Current Vibration Technology to Routine Ship Design Work," *The Naval Architect (RINA)*, January 1983.
- 3-2 Grant, J.W., and C.J. Wilson, "Design Practices for Powering Predictions," DTRC Report SPD-693-01, October, 1976.
- 3-3 Rutherford, R., "Aft End Shaping to Limit Vibration," *Transactions of the NECIES*, July 1979; see discussion by Moor and Nethercote.
- 3-4 Noonan, E.F., and S. Feldman, "State of the Art for Shipboard Vibration and Noise Control," *Proceedings of SNAME Ship Vibration Symposium*, October, 1978.
- 3-5 Jonk, A. and J.v.d Beek, "Some Aspects of Propeller Hull Interaction," a paper presented at the 5th Lips Propeller Symposium, 19-20 May 1983.
- 3-6 Odabasi, A.Y., and P.A. Fitzsimmons, "Alternative Methods for Wake Quality Assessment," *International Shipbuilding Progress*, February 1978.
- 3-7 Todd, F.H., Ship Hull Vibration, Edward Arnold Publishers, Ltd., London, England, 1961.
- 3-8 Saunders, H.E., Hydrodynamics in Ship Design, Vol. II, published by the SNAME, 1957.
- 3-9 Principles of Naval Architecture, published by the SNAME, 1967.
- 3-10 Vossnack, E., and A. Voogd, "Developments of Ship Afterbodies, Propeller Excited Vibrations," a paper presented at the Lips Symposium, 1973.
- 3-11 "Shaft Struts," NAVSEA Design Data Sheet (DDS) 161-1, June 1982.
- 3-12 "Control Surface Design," NAVSEA Design Data Sheet (DDS) 562-1, July 1984.
- 3-13 "Control Surface Structure Design," NAVSEA Design Data Sheet (DDS) 562-2, July 1984.
- 3-14 Wilson, M.B., D.N. McCallum, R.J. Bosswell, D.D. Bernhard, and A.B. Chase, "Causes and Corrections for Propeller-Excited Airborne Noise on a Naval Auxiliary Oiler," *Transactions of the SNAME*, 1982.
- 3-15 Wilson, M.B., "Review of Available Criteria for Identifying the Likelihood of Excessive Propeller Induced Vibration," DTRC Report SPD-1001-01, May 1981.
- 3-16 van Gunsteren, L.A., and C. Pronk, "Propeller Design Concepts, *International Shipbuilding Progress*," Vol. 120, No. 227, 1973.

Ship Vibration Design Guide

- 3-17 Skaar, K.T., and A.E. Raestad, "The Relative Importance of Ship Vibration Excitation Forces," Proceedings of the Symposium on Propeller Induced Ship Vibrations (RINA), London, England, 1979.
- 3-18 Holtrop, J., "Estimation of Propeller Induced Vibratory Hull Forces at the Design Stage of a Ship," Proceedings of the Symposium on Propeller Induced Ship Vibration (RINA), London, England, 1979.
- 3-19 Atlas, R., P.Y. Chang, D.P. Roseman, J.O. Scherer, C.A. Tomassoni, and L. Wechsler, "Technical Requirements for High Powered Single Screw Propulsion of Merchant Ships," MARAD Report MA-RD-940-79032, January, 1979.
- 3-20 Frivod, H., "Vibration Excitation Forces," Seminar on Ship Vibration, sponsored by Det Norske Veritas, June, 1977.
- 3-21 Chen, Y.K., et al., "Propeller and Main Engine Induced Ship Hull and Deckhouse Vibration Analysis of 30,850 DWT Oil Carriers," ABS Technical Report RD-87001, January 1987.
- 3-22 Chen, Y.K., et al., "Propeller Induced Ship Hull Vibration Analysis of Ecological Tanker," ABS Technical Report RD-81004, January, 1981.
- 3-23 Chen, Y.K. and Chiou, J.W., "Propeller Induced Ship Hull and Deckhouse Vibration Analysis of 64,000 DWT Bulk Carriers," ABS Technical Report RD-81002, January, 1981.
- 3-24 Chen, Y.K., et al., "Propeller and Main Engine Induced Ship Hull and Deckhouse Vibration Analysis of 1,400 TEU Containerships, Bay Shipbuilding Hulls 735/736/737," ABS Technical Report RD-87001, January, 1987.

APPENDIX 3-A

Example of Early-Design-Stage Estimate of Propeller-Induced Vibratory Forces and Moments*

SHIP CHARACTERISTICS

The ship characteristics, applicable to the T-AO 187 Class Fleet Oiler, as used in this study, are given in Table 3-A-1. The data as obtained from Levingston Marine [8, 9]. Supplemental inputs, as noted in the table or in other parts of the report, were developed or agreed to in technical discussions held between Levingston and NKF personnel at Levingston's Annapolis office on 13, 19, and 30 April 1982.

For purposes of this study, consideration has been given to either a four- or five-bladed propeller and shaft speeds of 80 to 90 RPM. Preliminary recommendations are given in this report, subject to confirmation by the results of the dynamic analyses of the shafting system being conducted in response to paragraph 4.4.2.6 of the contract.

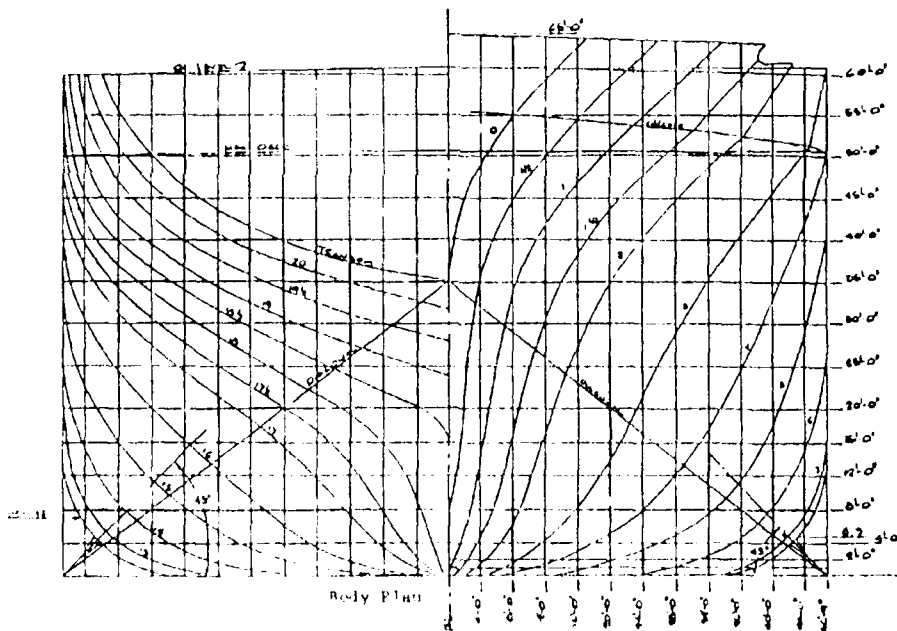

Figure 3-A-1

Hull Lines for T-AO 187 Class Fleet Oiler

* from "An Evaluation of the Proposed Hull Configuration," NKF Report No. 8213-001-1, May 1982

Ship Vibration Design Guide

Hull lines for the T-AO 187 Class are shown in Figure 3-A-1 and the propulsion shafting, as originally designed, shown in Figure 3-A-2. This configuration is used to evaluate propeller forces, propeller-hull clearances and cavitation effects. Recommended modifications to the shafting arrangements will be included in the second report.

Table 3-A-1 T-AO 187 Characteristics

Length Overall (<i>LOA</i>)	667 ft
Length Between Perpendiculars (<i>LBP</i>)	633 ft
Beam Molded (<i>B</i>)	93 ft 6 in
Depth (<i>D</i>)	50 ft
Draft (Maximum) (<i>d</i>)	35 ft
Draft-Scantling Molded (Type B) Approx.	37 ft 10 in
Displacement (Δ)	40,000 Long Tons
Length-Beam Ratio (<i>L/B</i>)	6.77
Beam-Draft Ratio (<i>B/d</i>)	2.67
Block Coefficient (C_B)	0.662
Prismatic Coefficient (C_P)	0.683
Midship Section Coefficient (C_M)	0.970
Midship Area Moment of Inertia (I_v) (Levingston) (4/19)	1,767,385 in ² ft ²
Wetted Surface	76,066 sq ft
Number of Shafts	2
SHP/Shaft*	16,865
Engine RPM*	430
Propeller Diameter (D_p) (CRP)	24 ft
Propeller RPM	80-90
Ship Speed (V_s)	20 knots
Number of Propeller Blades (<i>z</i>)	4 or 5
Wake Factor (1- <i>w</i>) (Levingston) (4/19)	0.932
Thrust Factor (1- <i>t</i>) (Levingston) (4/19)	0.8924

* Based on ABS (MCR) of Transamerica DeLaval/Stork Werkspoor 9 TM 620.

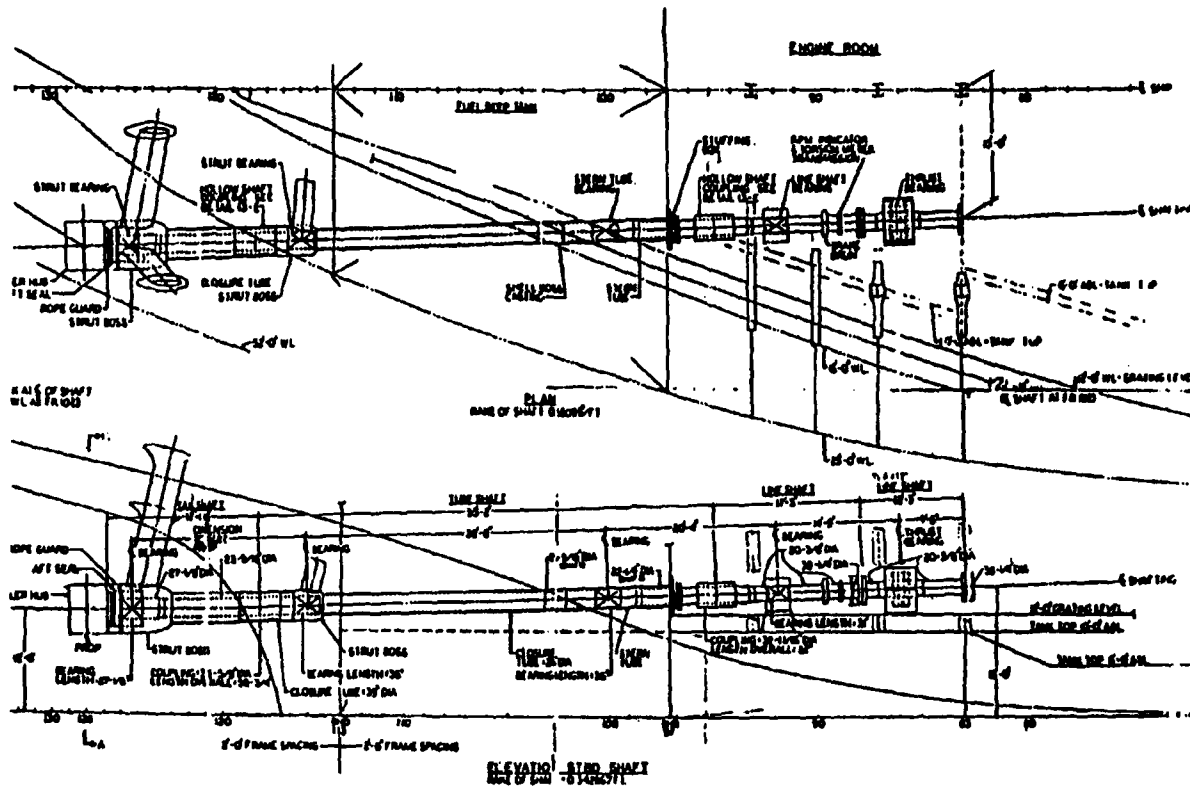

Figure 3-A-2

Original T-AO 187 Shafting Arrangement

SHIP POWERING REQUIREMENTS

3.1 Engine Characteristics

From model test results at 20 knots, Figure 3-A-3, $EHP = 17,600$. From NAVSEA T-AO 187 Specifications, Mod. I of February 5, 1982:

Propulsive Coefficient	0.68
Service Factor	15 %
Power Margin	1.5 %
Transmission Efficiency	0.98
Still Air Drag Factor CAH	3.5 %
Correlation Allowance	.0002

$$SHP = \frac{EHP}{.68 \times .98} = \frac{17,600}{.6664} = 26,410$$

Ship Vibration Design Guide

Correcting for power margin (.015) and CAH (.035):

$$BHP_{req'd} = \frac{26,410}{1.0 - .05} = 27,800$$

To operate at 0.87 MCR requires:

$$\frac{27,800}{.87} = 31,954 \text{ or } 32,000 \text{ BHP}$$

From Figure 3-A-4, the MCR of the Transamerica DeLaval/Stork Werkspoor 9 TM 620 is 16,865 BHP at 430 RPM, or 33,730 for two shafts.

It was agreed at the conference of 19 April 1982, between Levingston and NKF, that the rating of 16,865 BHP at 430 RPM would be used for determination of maximum shaft dimensions, with a corresponding shaft speed of 80-90 RPM. This would provide a service factor of:

$$1 - \frac{27,800}{33,750} \text{ or } 18 \text{ percent}$$

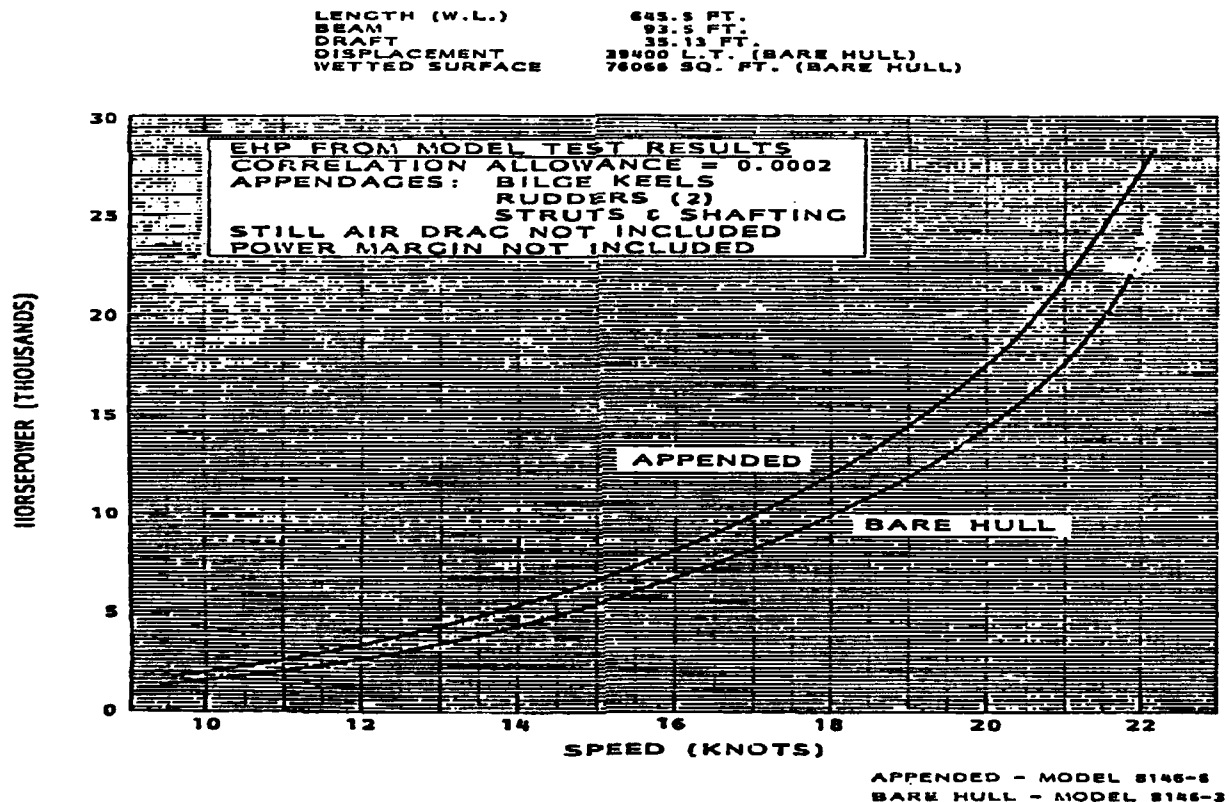

Figure 3-A-3

T-AO 187 Effective Horsepower Curves

3.2 Propeller Characteristics

The propeller design criteria calls for a sustained speed of 20 knots at 87 percent MCR, and highest possible thrust at very low speeds for maneuverability.

Since the shaft RPM (80-90) and number of propeller blades (four or five) were not initially fixed, data was requested for four- and five-bladed propellers at both 80 and 90 RPM. The analyses carried out under 4.4.2.6 and 4.4.2.7 are intended to provide recommendations for the final selection. With the diameter fixed at 24 feet for all propellers, the following propeller characteristics were obtained from Levingston on April 13, 1982:

	Four-Bladed Propellers		Five-Bladed Propellers	
	80 RPM	90 RPM	80 RPM	90 RPM
P/D	1.25	1.03	1.13	0.99
A_D/A_0	0.66	0.5	0.66	0.5
η_0	0.74	0.735	0.72	0.7

$$\eta_0 \text{ of } .70 \approx \eta_p \text{ of } .65 \text{ and } \eta_0 \text{ of } .74 \approx \eta_p \text{ of } .69$$

$$\text{NAVSEA } \eta_p \text{ of } .68 \times 32,000 \text{ HP} = 21,760 \text{ SHP}$$

$$\eta_p \text{ of } .65 \times 33,730 \text{ HP} = 21,924 \text{ SHP}$$

Thus, all four propeller characteristics would fit within the MCR of 16,865 HP of the Werkspoor engine.

$$\frac{21,760}{.65} = 33,477 \text{ or } 16,730 \text{ per shaft}$$

ESTIMATED PROPELLER FORCES

4.1 Assumptions

In the present analysis, we have proceeded on the assumption that factors other than the hull lines that would affect the vibration characteristics of the ship, such as the propeller skew, strut angles, propeller clearances, propeller cavitation, etc., will be optimized as part of the complete hull design in Phase II. At that time, the stipulated cavitation/hull pressure model studies should be designed, not only to report on the initial configuration, but to permit adjustments, as necessary, to improve the in-flow to the propeller disc area.

4.2 Approach

To obtain a preliminary estimate of propeller forces by which we can evaluate hull and machinery response characteristics, an estimate of these forces was made by direct comparison with the forces previously calculated for other twin-screw naval ships. In general, it has been

Ship Vibration Design Guide

found that the alternating forces will vary with the speed of advance coefficient, J , for ships having approximately equal block coefficients, where:

$$J = \frac{V_a}{nD}$$

$$V_a = V_s (1-w) \text{ ft/sec}$$

$$n = \text{Rev/sec}$$

$$D = \text{Propeller diameter, ft}$$

Estimates of propeller forces are extrapolated from those calculated for similar ship types. Table 3-A-2 gives the characteristics of comparative twin-screw naval ships. Figure 3-A-5 gives the alternating forces with respect to the advance ratio for the DD 963 Class destroyers and two other types of twin-screw naval ships, for which the propeller forces had previously been calculated and listed in Table 3-A-2. Both Figure 3-A-5 and Table 3-A-2 were taken from the DD 963 Preliminary Vibration Analysis [3].

Table 3-A-2 Characteristics of Comparative Twin-Screw Naval Ships

	Type I	Type II	Type III	Type IV	DD 963
z	6	5	4	5	5
V_s	33.4	22.00	34.00	29.00	Omitted
L	520.00	548.00	383.00	540.00	530.00
B	53.83	82.10	40.50	57.0	54.00
T	18.57	21.58	13.00	20.30	18.00 Des.
Trim by Stern	1.00	2.17	E.K.	E.K.	E.K.
Δ , Tons	7,000	17,000	3,051	9,217	7,500
L/B	9.70	6.67	9.45	9.50	9.62
C_B	0.469	0.589	0.529	0.514	0.480
SHP per Shaft	40,000	33,700	30,475	23,835	40,000
EHP/SHP	0.708	0.560	0.63	0.664	0.69
EHP	28,150	18,872	19,200	15,815	27,600
$1 - W$	1.023	0.905	0.983	0.970	0.980
$1 - t$	0.955	0.800	0.955	0.916	0.960
RPM	176.00	251.00	345.0	224.8	
D	18.33	12.50	12.00	15.00	17.00
\bar{T}	268,100	160,000	192,000	195,000	284,000
\bar{Q}	1,131,600	350,000	465,000	560,000	1,236,400
V_{WE}	1.47	0.942	1.74	1.24	1.43
\bar{T} in % of \bar{T}	± 1.70	± 0.98			± 1.79
\bar{Q} in % of \bar{Q}	± 1.30	± 0.46			± 1.26
\bar{F}_H in % of \bar{T}	± 1.50	± 0.32			± 1.43
\bar{F}_V in % of \bar{T}	± 1.00	± 0.42			± 1.00
J	1.08	0.839	0.815	0.845	1.13

Appendix 3-A - Example Problem

As in this case, a preliminary estimate of the DD 963 alternating bearing forces, thrust and torque was developed from the curves shown on Figure 3-A-5, using the calculated alternating force data shown for the ships identified as Type I and Type II, versus the advance ratio. The estimated values were taken from Figure 3-A-5 at the appropriate J value for the DD 963. These values show good agreement with the values shown in Table 3-A-2, which were predicted by calculations from an assumed wake and a standard propeller based on estimated propeller characteristics. The values estimated from Figure 3-A-5 were approximately 10 percent higher on the average than those obtained by the more detailed calculations. It should also be noted that when the average of the estimated and calculated values of the forces so obtained were used in predicting ship response, good agreement was obtained during the full-scale trials [5].

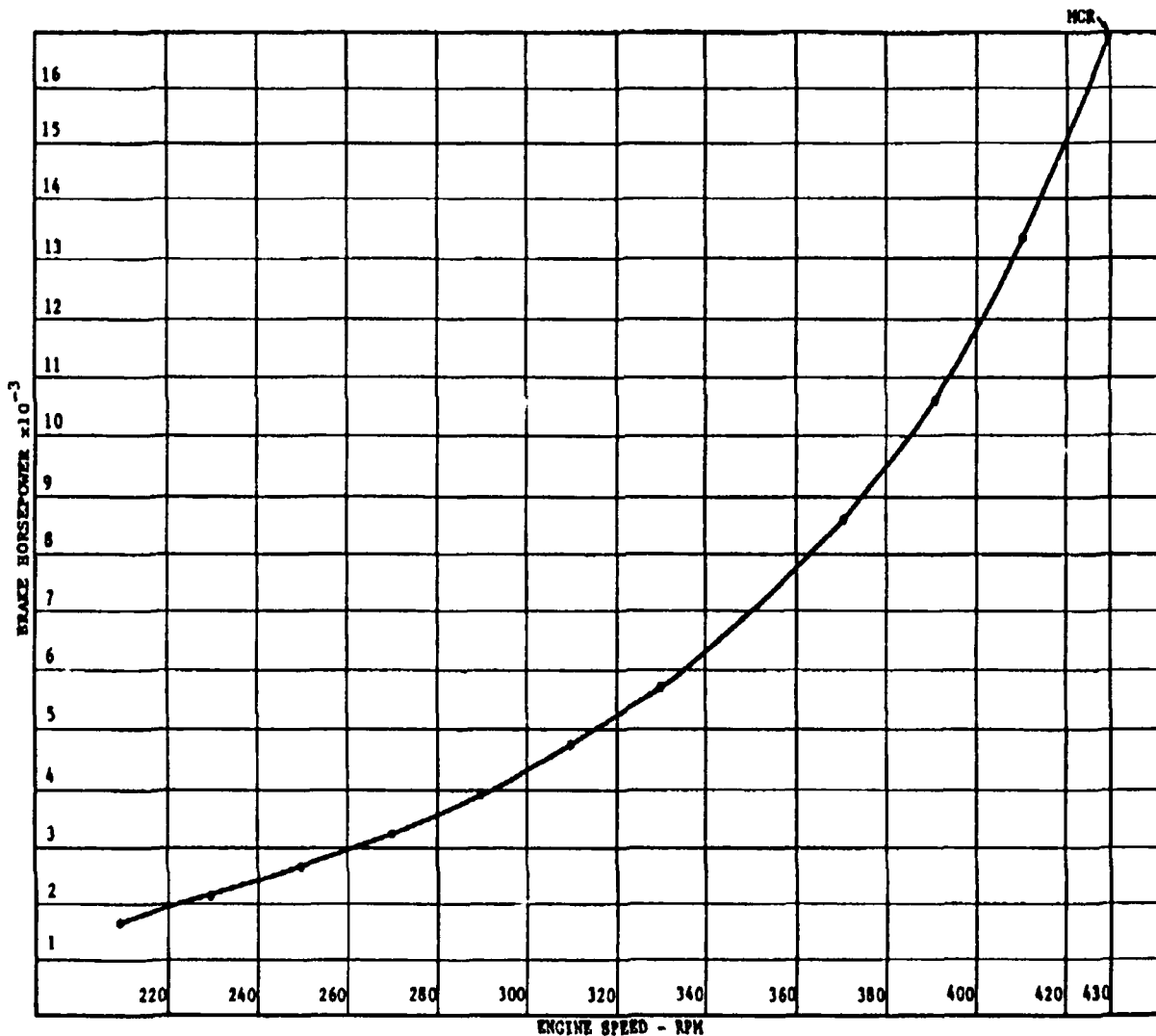

Figure 3-A-4

BHP versus RPM for SWD 9 TM 620

4.3 Estimated Forces

The advance ratio $J = V_a / nD$ is calculated for the T-AO 187 at 80 and 90 RPM, the lower and upper limits of the shaft speed range under consideration. In both cases, the propeller diameter is assumed to be 24 feet.

$$V_a = \frac{20 \times .932 \times 6072}{3600} = 31.44 \text{ ft/sec}$$

$$n = \frac{80}{60} = 1.33 \text{ for 80 RPM}$$

$$n = \frac{90}{60} = 1.5 \text{ for 90 RPM}$$

$$J = \frac{31.44}{1.33 \times 24} = 0.985 \text{ for 80 RPM}$$

$$J = \frac{31.44}{1.5 \times 24} = 0.873 \text{ for 90 RPM}$$

It should be noted, normally the propeller diameter could be expected to decrease as the RPM increased for the same power, thus reducing the difference between the above J factors.

At 20 knots, from Figure 3-A-3, the $EHP = 17,600$ or $8,800$ per shaft and the steady thrust is:

$$\bar{T} = \frac{326 \times 8800}{V_s (1 - t)} = \frac{326 \times 8800}{20 \times .8924} = 161,000 \text{ lbs per shaft}$$

At 20 knots, the total SHP was previously calculated to be $26,410$ or $13,205$ per shaft. At 80 RPM, maximum torque is developed and the steady torque is:

$$\bar{Q} = \frac{13,205 \times 33,000}{2\pi \times 80} = 868,000 \text{ ft-lbs per shaft}$$

$$\text{At 90 RPM, } \bar{Q} = 772,000 \text{ ft-lbs per shaft}$$

It should be noted that these values of steady torque and thrust relate to model test conditions at the design speed of 20 knots and represent the conditions normally used for computation of propeller forces from wake studies or from self-propelled model studies. Shaft design requirements include additional margins, as previously noted.

Appendix 3-A - Example Problem

Referring to Figure 3-A-5, the following propeller alternating forces, in terms of percentages of steady thrust and torque, for the T-AO 187 Class are obtained:

	80 RPM	90 RPM
\bar{T} Steady Thrust, lbs	161,000	161,000
\bar{Q} Steady Torque, ft-lbs	868,000	772,000
J Advance Ratio	0.985	0.873
\tilde{F}_V Alternating Vertical Bearing Force, lbs	0.8% = 1,300	0.55% = 890
\tilde{F}_H Alternating Horizontal Bearing Force, lbs	1.1% = 1,800	0.60% = 1,000
\tilde{T} Alternating Thrust, lbs	1.4% = 2,300	1.2% = 2,000
\tilde{Q} Alternating Torque, ft-lbs	1.0% = 8,700	0.7% = 5,400

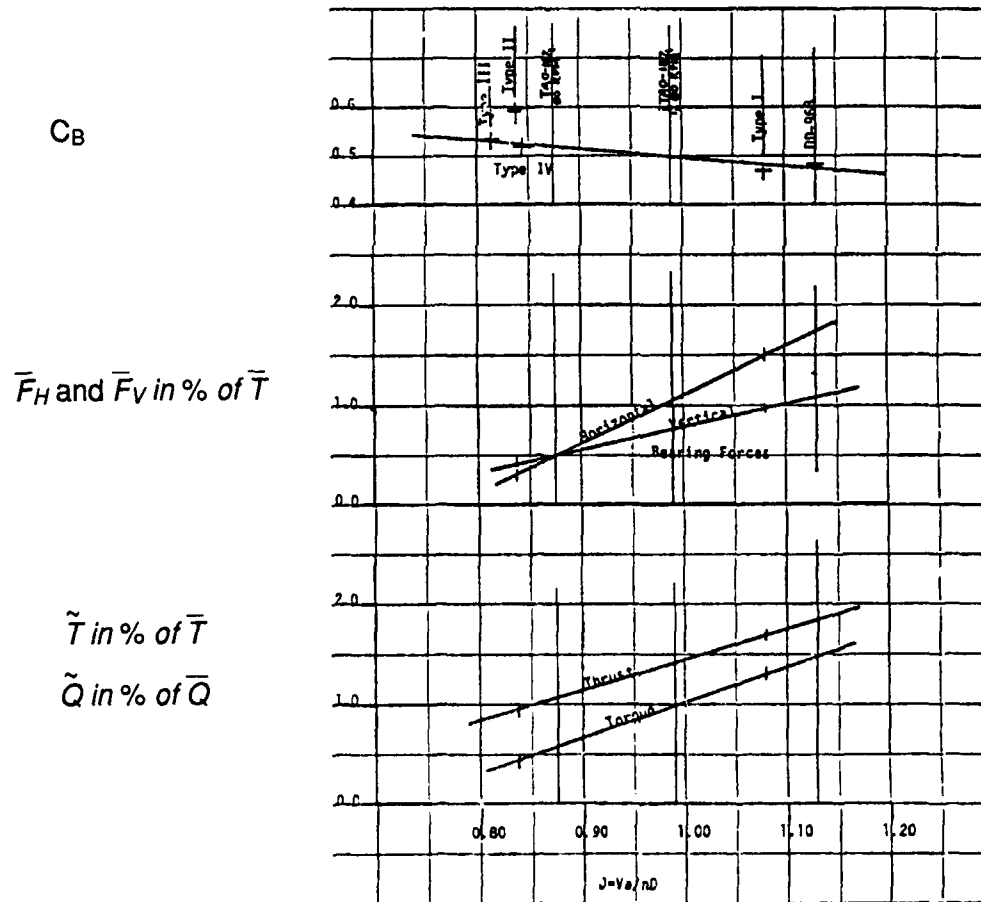

Figure 3-A-5

Calculated Propeller Forces for Comparative Twin-Screw Naval Ships

Ship Vibration Design Guide

Although the estimated propeller forces are expected to be lower when operating at 90 RPM, we consider the higher values, estimated for operation at 80 RPM, would be more representative for two reasons: first, the somewhat higher block coefficient (C_B of 0.662) of the T-AO; second, the likelihood that similar propellers would have a slightly smaller diameter when operating at 90 RPM than when operating at 80 RPM. This would tend to raise the advance ratio (J) and increase the forces.

As a basis for evaluating the vibratory response characteristics of the hull and machinery of the T-AO 187, the higher forces shown above in the 80 RPM column will be used. In the application of these forces we will relate to specific design/performance criteria where it exists, either in the specifications for the T-AO 187 or in other suitable standards, which based on our experience, would be more appropriate.

Based on the studies of Hadler and Cheng [10], the hull form chosen for the T-AO 187, the twin-screw open transom design, appears to be the best choice. However, the heavy skeg starting at Frame 117 should be evaluated in the prescribed model studies, along with the details discussed under 4.1, Assumptions. A less dramatic skeg, starting approximately at Frame 110, could possibly provide improved flow conditions to the propellers without adversely affecting maneuvering characteristics.

A word of caution should be introduced at this point in regard to the evaluation of design prediction against full-scale trial results. As in all such projections, it is necessary to ensure we are comparing like quantities and that all significant factors are taken into account. The following factors are of major importance and will be discussed in terms of the calculated bearing forces \bar{F}_V and \bar{F}_H generated by the propeller at blade rate, and the response of the hull to these predicted forces:

1. The bearing forces calculated from the wake and the propeller characteristics represent an average or approximately sinusoidal value.
2. The propeller also produces pressure forces on the hull and the hull reacts to the combined effect of both force systems. Although theoretical methods of predicting these forces have been developed in recent years, at the time of the development of the DD 963 (1970) they were unavailable. Indeed, today the combined effect cannot be reliably predicted analytically. It was about that time (1971) that von Manen [11] and Huse [12] identified the significant effect of cavitation on these forces and led to the development of the vacuum tank at the Netherlands Ship Model Basin in which the combined effect of these forces could be measured.
3. Cavitation effects, if serious, can radically increase the total hull force by factors of 10 or more - hence, our earlier note on the subject (see 4.1, Assumptions). To account for normal propeller-generated pressure forces we assume the addition of an equal and in-phase pressure force, combined with the bearing force, acting on the hull.

4. When relating the hull response to the predicted response, we must have a standard method of evaluating shipboard vibration measurements. Toward this end, the test codes [13, 14] evaluate the "maximum repetitive amplitude" under controlled test conditions. These trial conditions stipulate straight runs and sea-state 3 or less. Under these conditions, the trial results will indicate a factor of two greater than predictions. This was found to be the difference between the crest-factor associated with a random signal (2.5) and that used for the maximum value of a lightly modulating signal of RMS values (1.4). Thus, to account for the modulation influence of trial conditions, when compared to predicted response, a factor of two must be used ($2.5/1.4$).

5. Under adverse sea conditions and hard maneuvers, additional amplifications will occur. Caution should be used in this regard, however. For example, the combination of rough weather and hard maneuvers can be a reasonable expectation for combatant-type ships but not necessarily so for auxiliary types.

ESTIMATION OF HULL VIBRATION

5.1 Hull Forces and Moments

The total forces and moments acting on the hull and main machinery include both bearing and pressure forces and moments. The most significant, however, are those exciting the hull vertically and horizontally, the alternating thrust, which can excite the hull and propulsion system longitudinally, and the alternating torque, which will affect the propulsion system torsionally. To arrive at the input force estimates to the hull, we must include hull pressure forces generated directly by the propeller and augmented by cavitation effects, when present. In estimating the total hull forces in the absence of the necessary basis for their calculation or model studies in which the forces may be measured, we rely on our experience or "rule-of-thumb," which we successfully used on a similar (twin-screw, open-transom) design (DD 963), in which efforts were made to minimize cavitation effects. In that case, we assumed the alternating pressure force in the vertical direction was equal to, and in phase with, the vertical bearing force. Thus, the vertical hull force was equal to the alternating force derived above, multiplied by two, and again by two to include the phasing of two shafts.

The forces in the horizontal direction were limited to twice the bearing forces only, since little effect on the pressure forces is realized in the horizontal plane of the propeller.

The total longitudinal force on the hull is assumed to be the combined alternating thrust of the two shafts, entering the hull through the thrust bearing and in phase. The forces may significantly affect the response of an aft deckhouse.

The alternating thrust and torque, which can be expected to excite each of the two propulsion systems, will be subject to the estimated values shown. The total alternating propeller forces for use in estimating the T-AO 187 hull and machinery vibration characteristics, or as inputs to the dynamic analyses, are summarized as follows:

Ship Vibration Design Guide

Hull Forces

$$\tilde{F}_V \text{ Hull Vertically} = 2 \times 2 \times 1,300 = 5,200 \text{ lbs}$$

$$\tilde{F}_H \text{ Hull Horizontally} = 2 \times 1,800 = 3,600 \text{ lbs}$$

$$\tilde{T} \text{ Hull Longitudinally} = 2 \times 2,300 = 4,600 \text{ lbs}$$

Shaft Forces and Moments

$$\tilde{T} \text{ Longitudinally, each shaft} = 2,300 \text{ lbs}$$

$$\tilde{Q} \text{ Torsionally, each shaft} = 8,700 \text{ ft-lbs}$$

Note: The base values chosen were the more conservative (larger) values obtained for 80 RPM. This was done since the hull form has a higher C_B , is not as flat or clear as the DD 963 Class, and does not have the heavier skeg. It is expected that the model studies called for will be effective in optimizing the appendage characteristics and minimizing cavitation forces.

REFERENCES

1. Subcontract for T-AO 187 Baseline Review between NKF Engineering Associates, Inc., and Levingston Marine Corporation, April 7, 1982.
2. Noonan, E.F., "Design Considerations for Shipboard Vibrations," Marine Technology, January 1971.
3. Noonan, E.F., "Preliminary Hull and Machinery Vibration Analyses for DD 963 Class Destroyer Design," NKF Report No. 7105-4 to Litton Systems, Inc., 26 February 1971.
4. Noonan, E.F., "Vibration Considerations on Project and Conventional Hulls for 120,000 CM LNG Ships," NKF Report No. 7107, 28 May 1971.
5. NKF Engineering Associates, Inc., "*USS SPRUANCE*, DD 963, Vibration Trials Report," for Ingalls Shipbuilding Division, Litton Systems, Inc., Report No. 7404-2, April 1975.
6. NKF Engineering Associates, Inc., "El Paso Paul Kayser, Vibration Trials Report," for Methane Tanker Service Co., Houston, Texas, Report No. 7321-2, November 1975.
7. Noonan, E.F., "An Assessment of Current Shipboard Vibration Technology," Ship Structures Symposium 1975, SNAME Publication SY-5.
8. Levingston Marine Corp letter of 5 April 1982 forwarding T-AO 187 Class Fleet Oiler Design Information.
9. NAVSEA Specifications for Building Fleet Oiler, T-AO 187 Class, MOD I of 5 February 1982, received from Levingston Marine 13 April 1982.
10. Hadler, J.B., and H.M. Cheng, "Analysis of Experimental Wake Data in Way of Propeller Plane of Single- and Twin-Screw Ship Models," SNAME Transactions, 1965.
11. von Manen, F.D., "The Effect of Cavitation on the Interaction Between Propeller and Ship's Hull," presented at the IVTAM Symposium on Nonsteady Flow of Water at High Speeds, Leningrad, 1971.
12. Huse, E., "Propeller-Hull Vortex Cavitation," Norwegian Ship Model Experiment Tank Publication No. 106, May 1971.
13. ISO D-P 4867, "Code for Measurement and Reporting of Shipboard Vibration Data," September 1979.
14. SNAME Code C-1, "Code for Shipboard Vibration Measurements," January 1975.

SHIP HULL VIBRATION

Chapter One provided a general review of shipboard vibration and noted that the hull girder responds as a free-free beam when subjected to dynamic loads. The discussion in Chapter One also referred to the many other dynamic systems included in the total ship vibration problem, the sources of excitation and the interaction between the various systems. The principal dynamic systems considered in this design guide are the hull girder major substructures and the main propulsion system from the prime mover to the propeller. In this chapter, primary consideration is given to the hull girder and major substructure, including their natural frequencies of vibration; response to the exciting forces developed in Chapter Three; and their interaction with other dynamic systems.

The fundamental elements of a vibrating system includes the basic mass-elastic properties as well as damping and exciting forces. In order to control or limit the vibratory response it is necessary to modify the mass-elastic properties by increasing the damping, reducing the exciting forces or changing the exciting frequencies. *Increasing the damping* may be useful in the solution of local structural vibration problems and in certain machinery and equipment problems but is not a practical solution for reducing hull girder vibration.

In this chapter, the hull girder, along with its major substructures and local structures, is the basic mass-elastic system. The primary hull girder exciting forces considered in this chapter originate in the main propulsion system where the propeller and large diesel engines are the main contributors. The objective of the hull designer is to avoid resonance with the exciting forces emanating from the propulsion system elements, thereby minimizing hull girder response and thus reducing the transmission of vibration to major substructures, local structures, machinery and equipment. If resonance with elements of the propulsion system cannot be avoided, then it is the responsibility of the hull designer to evaluate the response with relevant criteria and make recommendations for modifications to the ship design so that the ship's response will meet accepted criteria.

4.1 The Design Approach

In the introduction to this design guide, it was noted that the reliability of the ship structure, primarily based on its response to the transient forces produced by heavy seas, is established by the rules of the classification society. Since the classification rules are periodically updated to reflect current practice with information on new development broadly exchanged, it may be generally concluded that all seagoing ships designed to classification society rules can be

Ship Vibration Design Guide

expected to dynamically respond similarly to vibratory forces, for a given ship type. This has been well established in the literature by Todd, [4-1], Lewis, [4-2] and many other references noted in these publications.

To insure minimum vibration in a proposed new design; avoid damage to structures, machinery or equipment (mechanical suitability); and to satisfy habitability requirements, a detailed vibration analysis of the proposed design is required. Such studies apply to the vibration of the main hull girder; principle substructures (deckhouse) that can respond to the motion of the hull girder; and the main propulsion system, as excited by the alternating forces originating in the main propulsion system. The response of these basic systems directly relate to the reliability of the drive system and to the vibratory inputs to the ship's equipment and personnel. The vibration environment to which the ship's equipment and personnel are subjected will greatly influence the efficiency and reliability of the total ship system.

4.1.1 Scope of Ship Vibration Analyses

The scope of a total ship vibration analysis may be briefly encompassed in the following four phases:

- A. Preliminary hull and main machinery vibration analysis
(To determine approximate system vibration characteristics; to identify conflicts or likely failure to meet specifications; and to recommend necessary design modifications as early as possible.)
- B. Final hull and main machinery vibration analysis
(To more accurately determine the system characteristics and confirm the final design configuration.)
- C. Evaluation of local hull and equipment vibration characteristics during design
(To determine predicted response of local structures and the adequacy of installation details of selected items of equipment. Inputs are based on hull response determined in "B" and/or inputs from specific items of rotating equipment.)
- D. Test and service evaluation phase
(To determine actual ship and equipment performance in relation to design objectives or specifications; to identify corrective action, if necessary; and to develop improved data base.)

In theory, Phases A and B form the basis for the frequently referred to "Design Cycle" in which modifications and/or refinements in the design are introduced. In this design guide, it will be shown that simplified procedures can be used effectively to provide reasonable assurance that the specified vibration requirements can be achieved by performing relatively simple preliminary vibration analyses based on empirical data. This procedure should be effective for most low-budget projects.

Although this chapter deals particularly with hull vibration, the hull girder response will directly relate to the exciting forces developed in Chapter Three. Interaction between the hull

response and major substructures and the main propulsion machinery is addressed. The detailed machinery vibration analyses are included in Chapter Five. Procedures for vibration measurement and analysis are included in Chapter Six.

4.1.2 Contractual Considerations.

Depending on the individual shipbuilding program, detailed requirements to be recommended for each of the above four phases could vary significantly. Certainly the development of a multiple ship program would warrant a more detailed study than could be justified for a one or two shipbuilding program of a typical ship type. In all cases, however, the preliminary hull and main machinery vibration analyses are considered mandatory, unless the program was simply a repeat of an existing design having known and satisfactory vibration characteristics.

The specific scope of preliminary vibration design analysis, including applicable specifications, should be considered part of a total shipbuilding package with the owner and builder jointly determining the degree of responsibility to be shared in the total effort. If the shipbuilder is also responsible for the development of the design, he would be expected to assume complete responsibility but could share it with subcontractors, particularly engine builders, propeller manufacturers or other suppliers. If however, the owner, independently or with the support of a naval architectural firm, develops the design details required for construction, then most of the responsibility would be his. In practice, this division of responsibility is normally shared and can vary in each case. The important point here is the recognition that shipbuilding is a shared responsibility and is best carried out as a joint venture as recommended by Boylston and Leback [4-3].

It is obvious from the above considerations that the vibration requirements for a shipbuilding contract must be included as a line item, together with an estimated cost. To omit this could either jeopardize the design or penalize a more conscientious bidder.

4.1.3 Stages of Ship Design

There are many ways to break down the ship design process into stages, depending on the owner, designer and ship type. However, for the purpose of this guide, the seven stages of ship design are defined as suggested by Taggart [4-4] and it is up to the reader to fit their job and the required vibration analyses into these definitions.

4.1.3.1 Concept Design

This is where the owner's basic requirements are translated into naval architectural and engineering characteristics. Concept design consists of technical feasibility studies to estimate such fundamental elements of the proposed ship as length, beam, depth, draft, displacement, light ship weight, capacity, speed, power and range. Alternative designs are analyzed in parametric studies in order to optimize controlling parameters. The concept design is specified in the form of general characteristics and arrangement used to estimate construction and operating costs.

4.1.3.2 Preliminary Design

In the preliminary design phase, the ship's general characteristics, arrangement, propulsion and structure are further refined as are performance and construction costs. By the end of preliminary design, the major ship characteristics, such as length, beam, depth, capacity and power would not be expected to change. Completion of preliminary design results in a precise definition of the ship that will meet the owner's basic requirements and provides the basis for the next stage of design development.

4.1.3.3 Contract Design

Contract design yields a set of plans, specifications and other documentation that will be used for shipyard bidding, and will form an integral part of the shipbuilding contract. This stage of design encompasses one or more loops around the design spiral, thereby further refining the preliminary design. This stage delineates more precisely such features as hull form, type of propulsion, number of propellers and RPM, sea keeping and maneuvering characteristics, hull materials, structural arrangements, major scantlings and an accurate weight and center of gravity estimate. The final general arrangements developed in this stage fixes the arrangement and location of the propulsion system, accommodation spaces and cargo holds as well as their interrelationship, plus other features such as cargo handling equipment and machinery components. A final midship section is also developed at this stage which fixes the hull girder structure in the middle 40% of the ship. Other plans usually developed in contract design include: lines plan, scantling plan, arrangement of machinery and shafting, critical system diagrams, electric load analysis, capacity plan, curves of form, flooding and damaged stability calculations. The accompanying specifications delineate the quality standards of hull and outfit, the performance of each item of machinery and equipment, and numerous other details that cannot be included in a few plans. The specifications also describe tests and trials that shall be performed successfully in order that the ship be considered acceptable. Once a contract is signed, the contract design becomes the basis for the next phase of the ship design. Contract design is considered by some to be the product of the design process.

4.1.3.4 Detail Design

The next stage of ship design is the development of detailed working plans. These plans are usually developed by the shipbuilder or his agent and describe in extraordinary detail the ship's construction, assembly, machinery and equipment installation, and initial testing in terms the shipyard workers can easily understand. While all the ship's characteristics are defined in the contract design, within the contract there is a great deal of latitude allowed in detail design.

4.1.3.5 Construction

For a ship designer employed by a shipyard or as an owner's representative, there is a considerable amount of theoretical and practical design work to be done during construction. This is also where the designer first gets to see if his design works and if not, he must develop a fix within the constraints of cost and schedule.

4.1.3.6 Tests and Trials

This is usually not considered a stage of design but is included here because it is the proof of the design. Each ship designer has the responsibility to carefully consider the results of all tests

and trials to evaluate his performance in the design; to do his best to fix those features of the design that do not operate according to the specifications; and to apply the experience, good or bad, into the next design.

4.1.3.7 Ship Operation

Again this is not often considered a part of ship design, but it is included because experience gained from the ship's operation is the ultimate proof of a design.

4.2 Preliminary Hull Vibration Design Analysis

As previously noted, the owner's basic requirements are translated into naval architectural and engineering characteristics during the concept design phase. Technical feasibility studies are carried out to determine the fundamental characteristics of the proposed ship. Alternative designs may be analyzed in order to determine the most economical design, consistent with other controlling parameters. In some cases shipboard vibration has been an important parameter.

During concept design, objectives relative to vibration requirements should be established since the stern configuration, choice of propellers and main propulsion machinery significantly influence the vibratory forces generated. A preliminary review of the proposed design concept should be carried out by a naval architect or marine engineer experienced in shipboard vibration to identify areas of potential problem and to recommend any required modifications.

In some cases, such as a 125,000 CM LNG Carrier where the estimated SHP required on a single screw ship exceeded the maximum power installed up to that time by 25%, more extensive vibration studies are required. Model studies were conducted on three different hull designs to obtain speed and power requirements and wake data. Self-propelled models were run to obtain propeller vibratory forces and extensive theoretical propeller force studies were carried out to optimize the propeller selection. Detailed vibration studies were carried out during preliminary, contract and detail design to avoid structural resonances. Similar studies were also carried out at about the same time for a new destroyer development program. Both were high powered, unique ships of vastly different characteristics and high budget projects that justified the concern and expense of the extensive vibration investigations. Simplified vibration analyses were also carried out, in parallel, to determine applicability. Both ships were successful designs with regard to hull vibration characteristics and were reported on by Noonan [4-5] in 1975.

While such extensive vibration avoidance programs are not warranted in most commercial projects, preliminary hull and main propulsion machinery vibration analyses are considered mandatory, if vibration problems are to be avoided. As an example, no one would consider omitting torsional and longitudinal vibration analyses of a proposed propulsion system. Although not as well defined in the literature, it is considered that similar concern should be given to hull vibration. Toward that end, the preliminary hull vibration design analysis suggested in this chapter should provide an indication of probable compliance with vibration requirements and identify potential problem areas, if they exist. The recommended procedures

Ship Vibration Design Guide

are primarily empirical, easily applied, inexpensive and subject to continued improvement with experience. The work should be carried out in parallel with the preliminary design phase.

4.2.1 Hull Frequency Determination

The most important requirement to minimize hull vibration, after the necessary steps are taken to limit the exciting forces, is to avoid resonance of the hull girder with the frequency of exciting forces. This section addresses the alternate methods available to calculate hull natural frequencies and demonstrates a simplified, empirical method that can be used in the preliminary hull vibration analysis.

4.2.1.1 Empirical Analysis

As early as 1894, Schlick [4-6] developed an empirical formula based on modification of an ordinary beam, which approximated fundamental bending frequency. By introducing empirical factors obtained by systematic shipboard vibration studies, it was possible to estimate the fundamental vertical frequency of a ship. Recognizing the importance of determining the natural frequencies of ships in the early design stage, a number of investigators have developed improvements to the Schlick formula, as discussed by Todd [4-1]. Further improvements are continuing in this direction for the obvious reason of obtaining a simplified and effective way of predicting the vibratory response of a ship's hull. A study by Disenbacher and Perkins [4-7], demonstrates a further refinement of this simplified approach, which would provide the natural frequencies of a ship's hull, within $\pm 5\%$ of that obtained by the more conventional 20-station beam model, which requires a complete distribution of ship parameters.

4.2.1.2 20-Station Beam Model

The 20-station beam model, frequently used for preliminary design purposes, was developed at the David Taylor Research Center [4-8], [4-9]. For each station along the length of a hull, it is necessary to develop the weight, virtual mass, bending rigidity and shear rigidity. This of course, requires firm design data that is not necessarily available in the early stages of design, and considerable engineering time to assemble and calculate. An early digital computer program for solving the system of finite-difference equations that approximate the problem representing the steady-state motion of a vibrating beam-spring system, such as a ship hull in bending, was also developed at DTRC. This FORTRAN II program is referred to as Generalized Bending Response Code 1, (GBRC1) was developed specifically to handle hull and shafting vibration analyses. A description and details for usage of the General Bending Response Code was prepared by Cuthill and Henderson [4-10]. A detailed hull and machinery vibration analysis, in which this beam model was used on a Coast Guard Icebreaker preliminary design was published in Marine Technology, [4-11].

Hull vibration analysis of the *France-Dunkerque* (F-D) 125,000 CM LNG Carrier, using the 20-station beam model, was carried out in 1975 [4-12]. The STARDYNE program employed in this analysis uses the finite-element method for structural analysis and was developed by Mechanics Research, Inc. (available through Control Data Corporation). Detailed information on this program is contained in references [4-13] and [4-14]. Results of this study were documented in [4-12].

4.2.1.3 Finite Element Model

A hull frequency study was also carried out on the Avondale 125,000 CM LNG Carrier by finite-element analysis. The aft part of the ship, from the stern to BHD 104 (shown in Figure 4-1) was modeled by dividing the hull into sections of structures between web frames along the length of the ship. The propulsion system, consisting of propeller, shafting, bearings, gears, etc. was represented by beams and concentrated weights. The finite-element model of the aft part of the ship, including the propulsion system, is shown in Figure 4-2.

The fore-body of the ship forward of Frame 104 was modeled by 15 elastic beams of appropriate cross-sectional properties. At Frame 104, where the aft-body finite element model coupled with the fore-body beam model, a rigid beam system was utilized to ensure a continuous transmission of motion to the interface. The complete finite-element ship model, incorporating the aft part, the fore body and the propulsion system of the Avondale LNG ship is shown in Fig. 4-3. This model has about 1450 finite-elements of beam and plate, with approximately 630 joints (or nodes) as inter-joining points. With each node having six degrees of freedom (DOF), the mathematical model consists of mass and stiffness matrices of the order of 3780. Computations with matrices of such an order of magnitude are very costly and not warranted to determine hull frequencies. Reduction of matrix size was therefore undertaken.

To accomplish reduction of matrix size for the finite element model, a mathematical program termed GUYAN Reduction was utilized. Application of this reduction of DOF is made feasible by assuming that many fewer joints or node points are needed to describe the inertia of a structure than are needed to describe its elasticity [4-15]. For this ship model, the GUYAN Reduction program was used to redistribute the ship's masses to a set of node points with 28 resultant degrees-of-freedom. This reduction process gave 28 corresponding natural frequencies of the ship model. An analysis employing the 20-station beam model, as used on the F-D hull, was carried out, for comparison purposes, with good results. This study was documented by Reference [4-16]. The finite-element model of the stern portion of the ship can also be used to evaluate the response characteristics of the deckhouse and shafting system if serious hull girder resonances are indicated.

A more detailed finite-element analysis, in which the entire hull is represented, may be developed by the NASTRAN computer program [4-17], where the mode shapes are obtained by solving the generalized eigenvalue problem represented by the equations:

$$K \{ \theta \} = \omega^2 M \{ \theta \}$$

where:

- K = symmetrical square stiffness matrix
- M = diagonal mass matrix
- { θ } = column mode matrix
- ω = natural frequency

A typical model for a product carrier, as developed by the American Bureau of Shipping (ABS), having 2680 degrees of freedom, is shown in Figure 4-4. A free vibration analysis

Ship Vibration Design Guide

Ship Characteristics:

L_{pp}	Length between Perpendiculars	886 ft
L_{wl}	Length on Water Level	903 ft
B	Beam	140.5 ft
T	Draft	36 ft.
Δ	Displacement	3,320,000 ft ³
	Light Ship Weight	32,000 long tons
	Loaded Ship Weight	96,000 long tons

The following sketch gives a rough graphic description of the ship. The tanks are located forward of Frame 104, while the machinery and deckhouse structure are located aft of Frame 104.

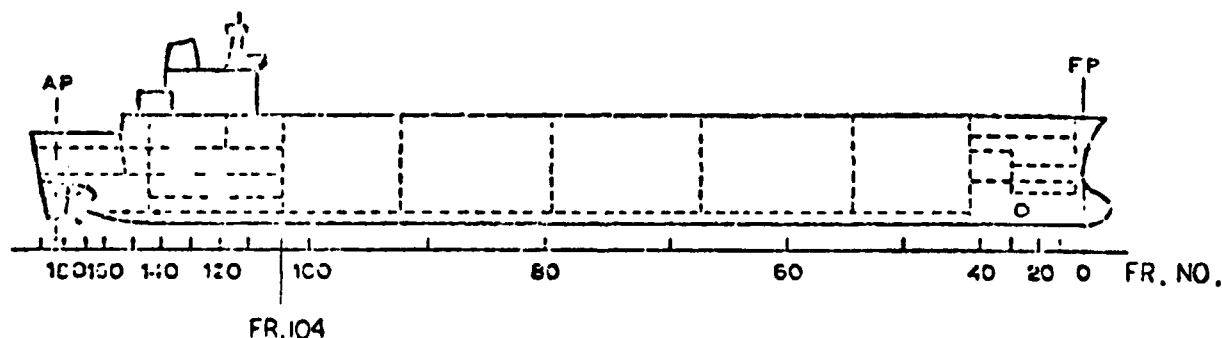

Since the stern is the location where excitation forces due to propeller action are at their peaks, and deck-house-structures are our biggest concern, it was therefore decided that a detailed modeling of the ship hull aft of Frame 104 would be necessary for vibration assessment. As for the fore body of the ship forward of Frame 104, representation by a beam element with proper sectional properties would be sufficient for vibration assessment purposes. At Frame 104 where detailed finite-element model of the aft ship coupled with the beam-like fore-body model, proper care had been taken to ensure complete transmission of motion across this interface.

Figure 4-1

Avondale LNG Ship, Modeling Procedure

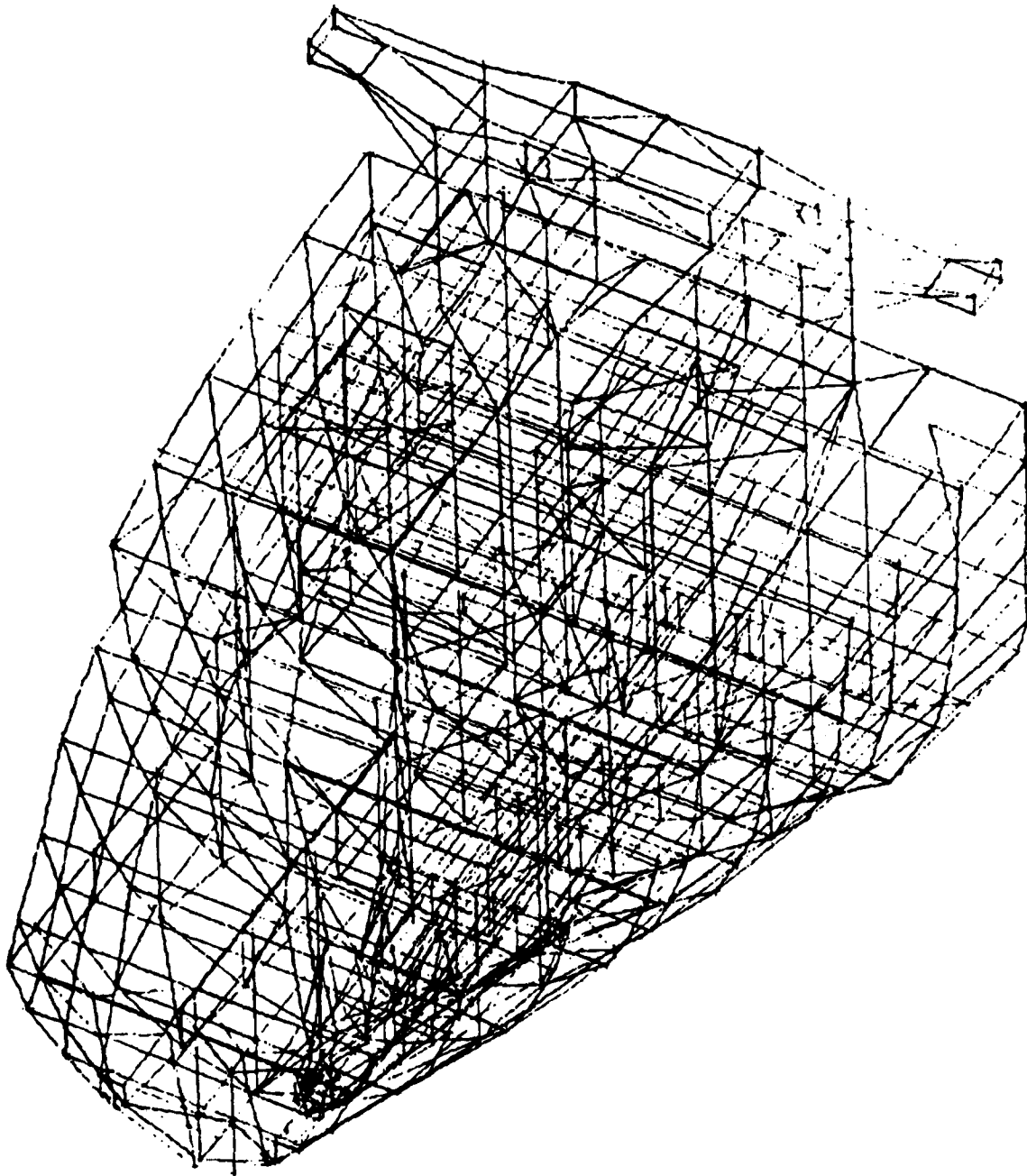

Figure 4-2

Avondale Hull Finite Model Aft of BHD 104, 3-D View

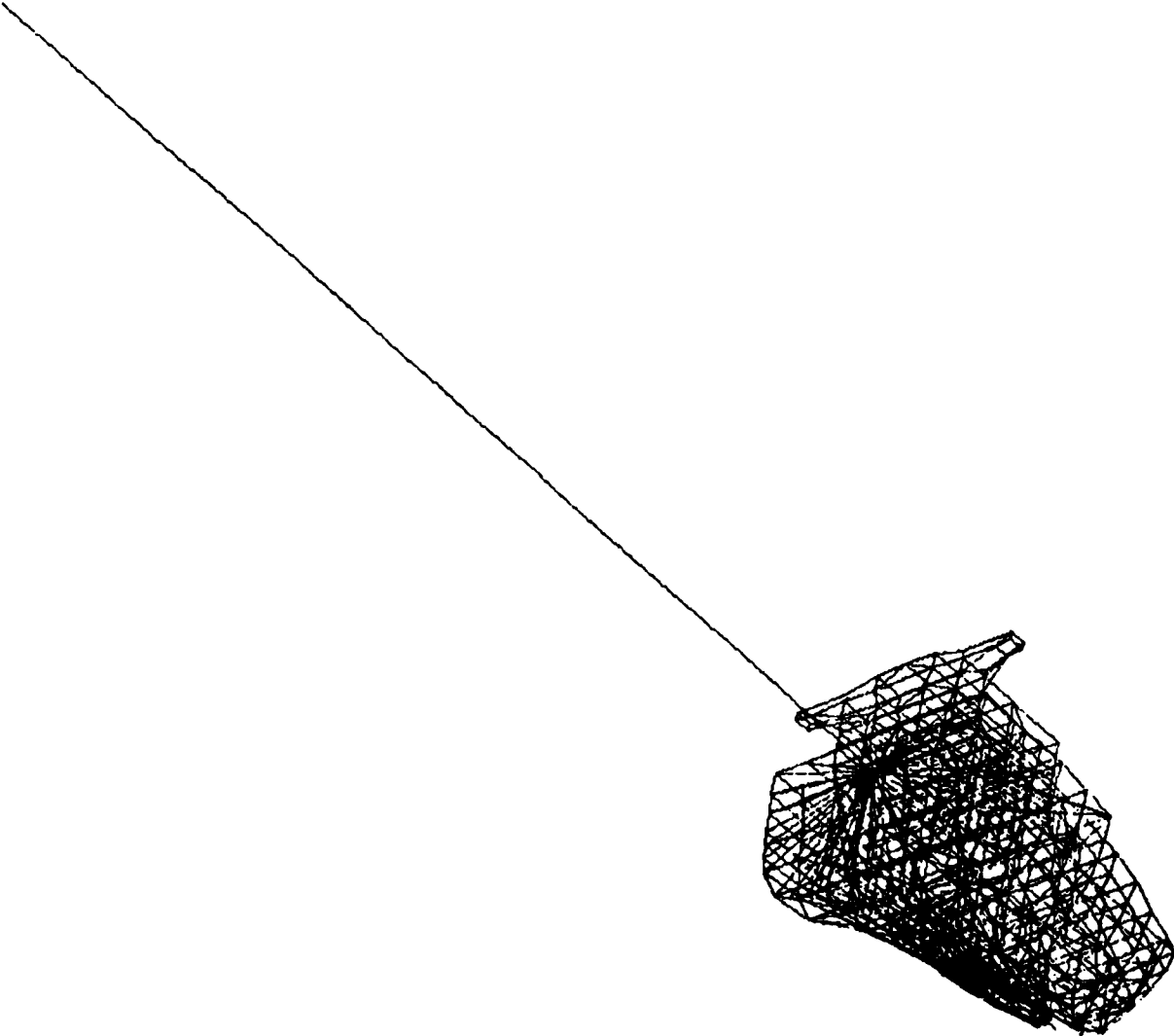
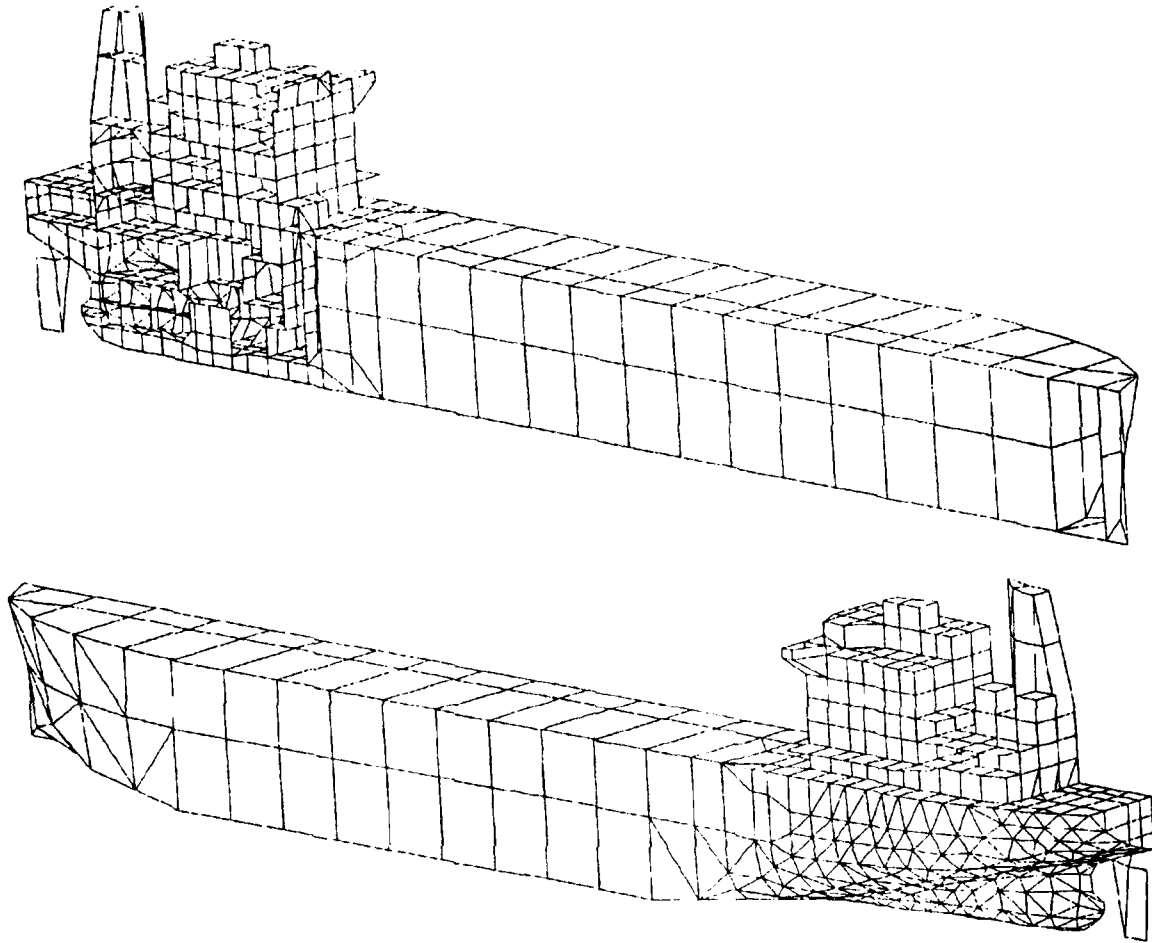

Figure 4-3
Avondale Hull Complete Ship Model, 3-D View

**Figure 4-4**

Isometric View of Finite Element Model

would also produce 2680 frequencies. For determination of the basic hull frequencies however, only the lowest frequencies are required. Figures 4-5 to 4-9 show the rigid body motions and the undamped vertical mode shapes for the seven vertical bending and first longitudinal modes. Higher frequencies can be used to indicate hull girder vibration coupled with deckhouse and local vibrations and will represent the response of a three-dimensional finite-element model, as opposed to the usual free-free beam representation of the ship.

The use of the finite-element model analysis requires the geometry of the structure to be analyzed. In the early design phase, the detail required for a vibratory response analysis is generally not available. If it is necessary to make assumptions on the structural details and the boundary conditions, the accuracy expected of the finite-element analysis is lost and the expense is not warranted. The recommended approach would then suggest the use of an empirical approach, or the 20-station beam model for preliminary design purposes and reserve the use of the finite-element analysis for the contract and detail design phases, if considered necessary at that point.

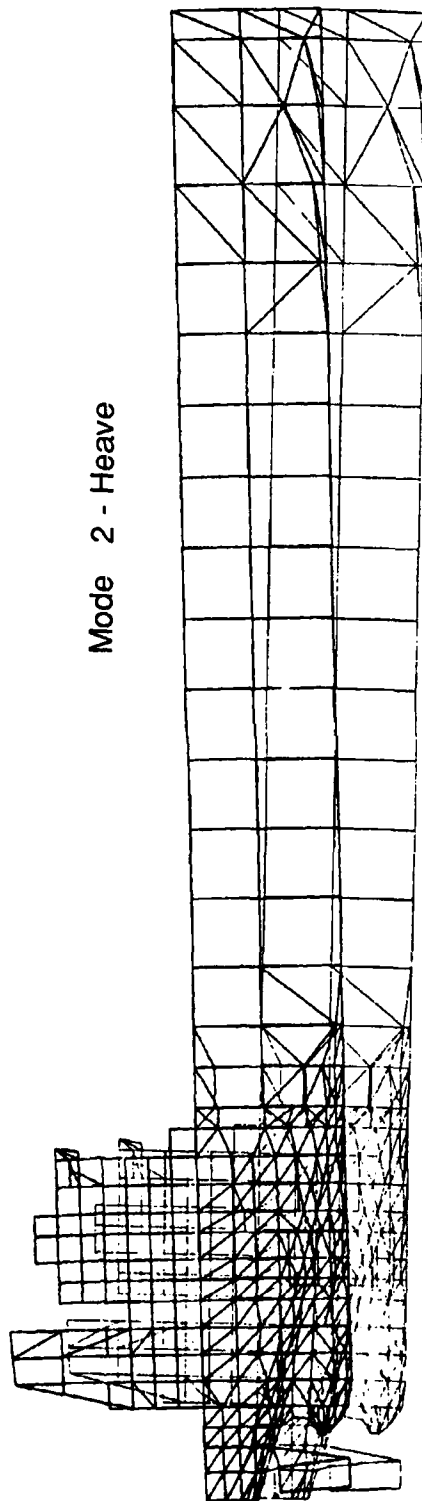
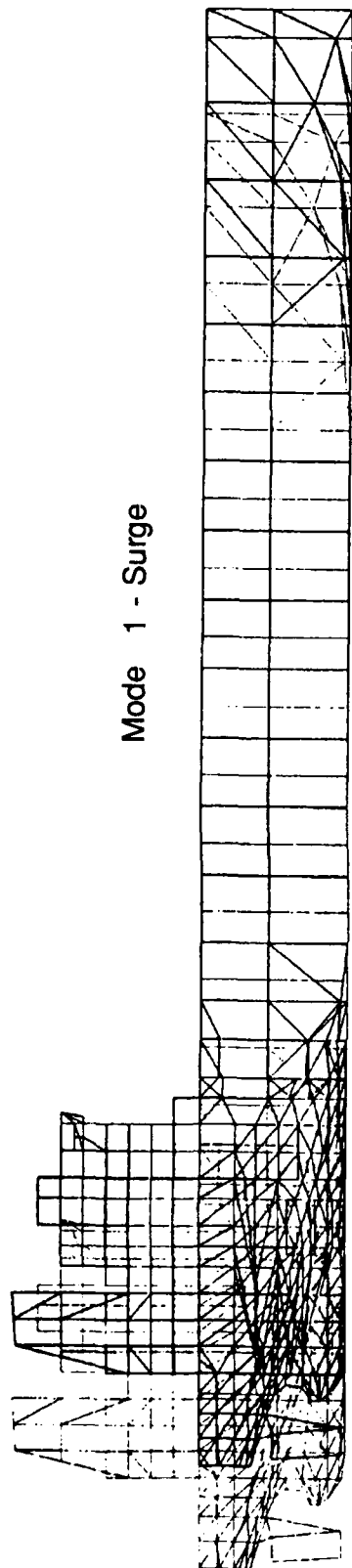

Figure 4-5

Eigenmodes in Full Load Condition

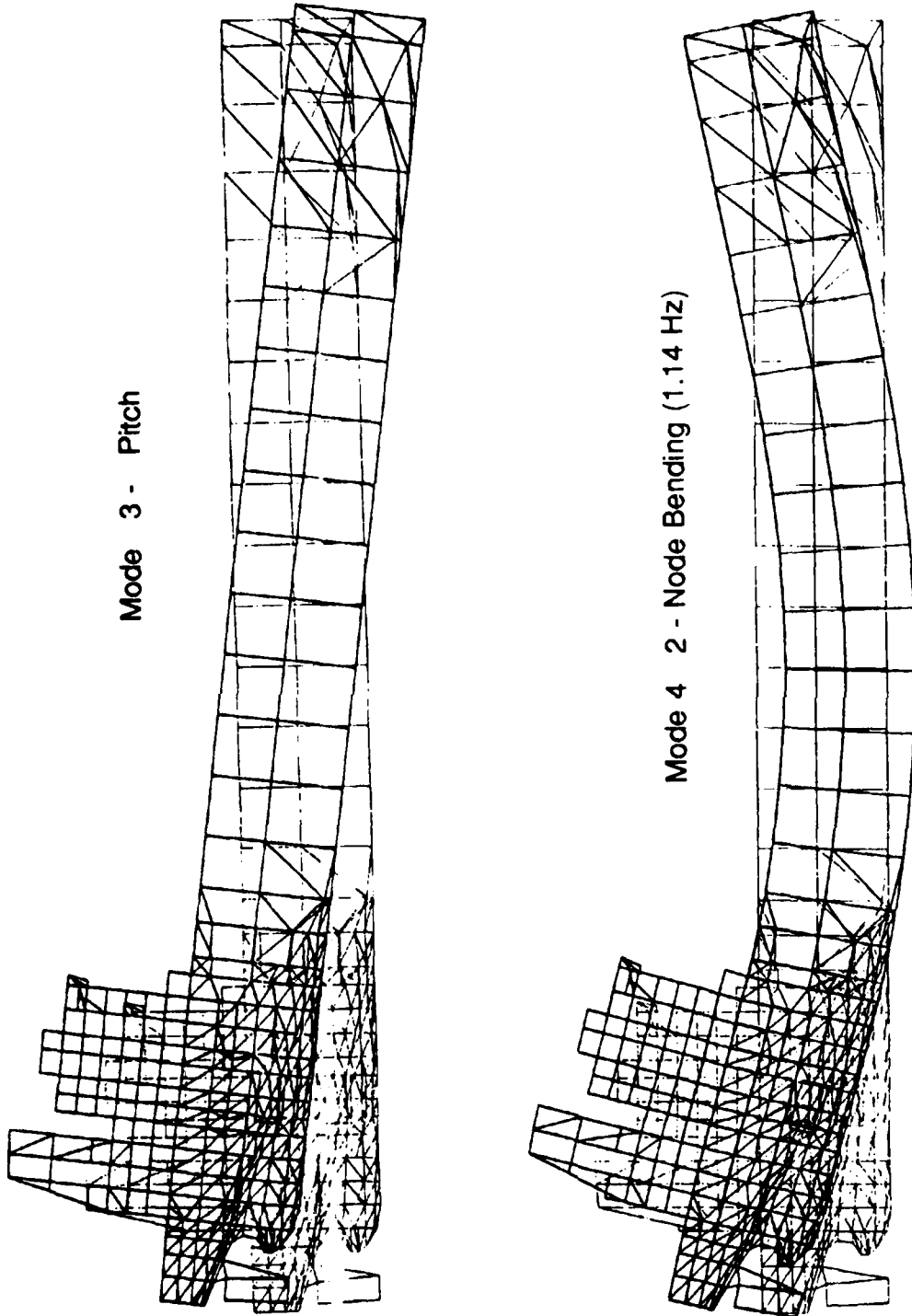

Figure 4-6

Eigenmodes in Full Load Condition

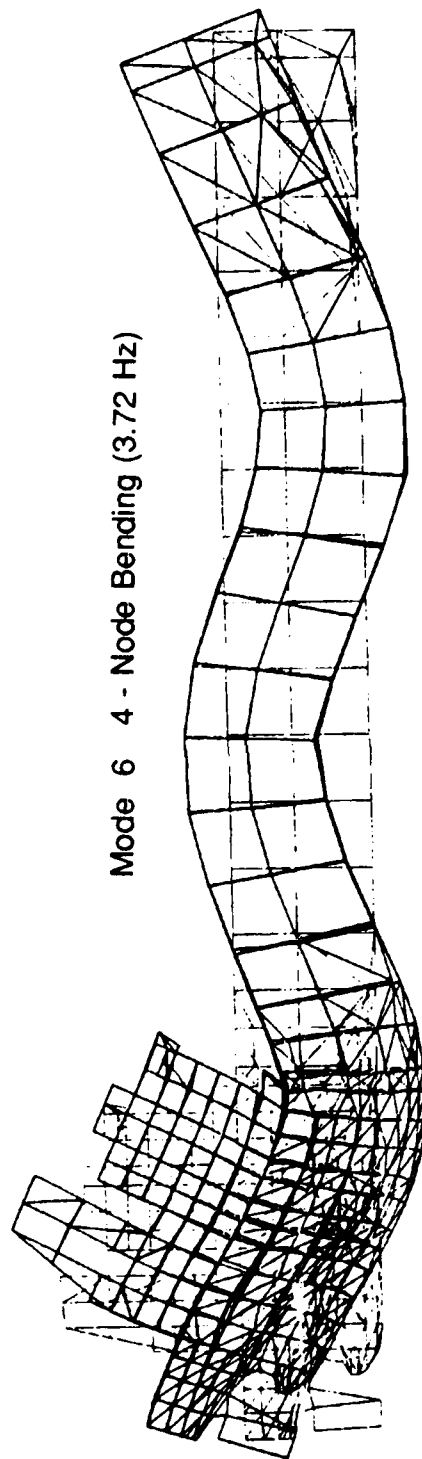
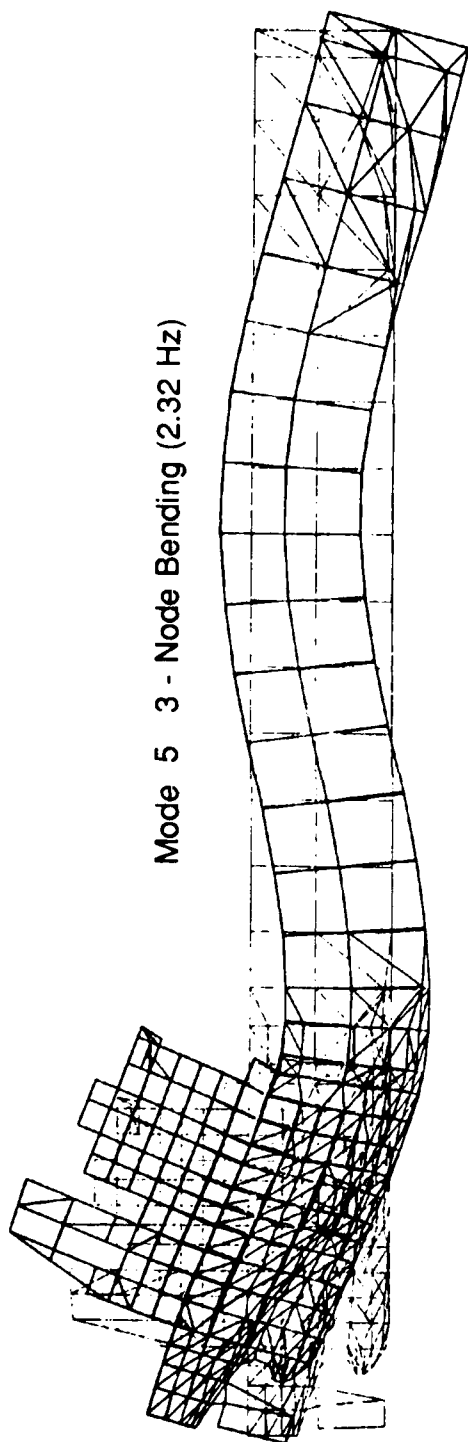

Figure 4-7
Eigenmodes in Full Load Condition

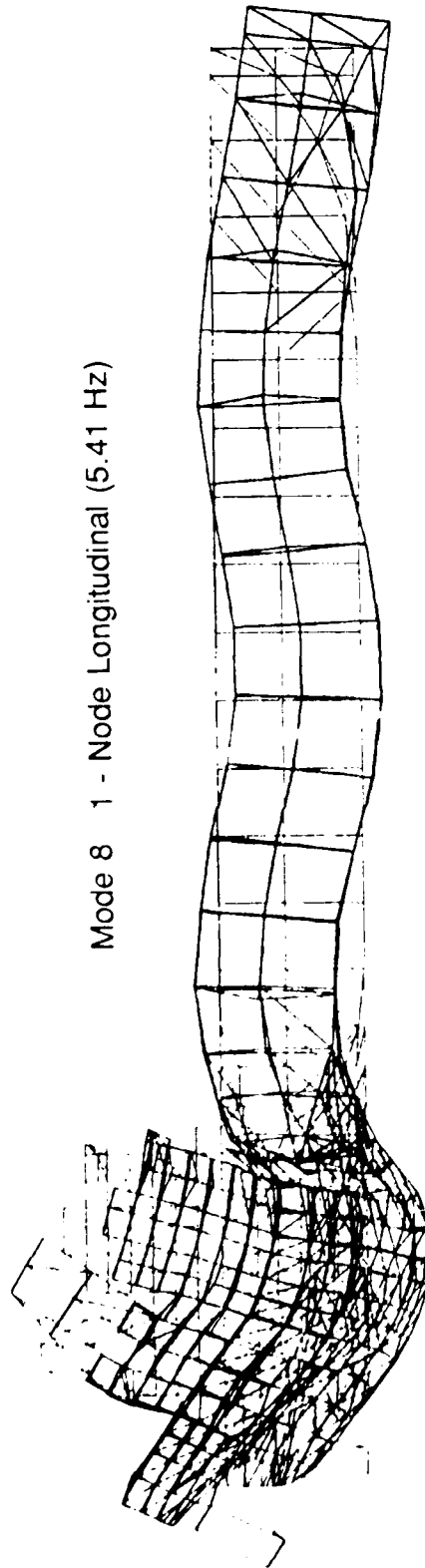
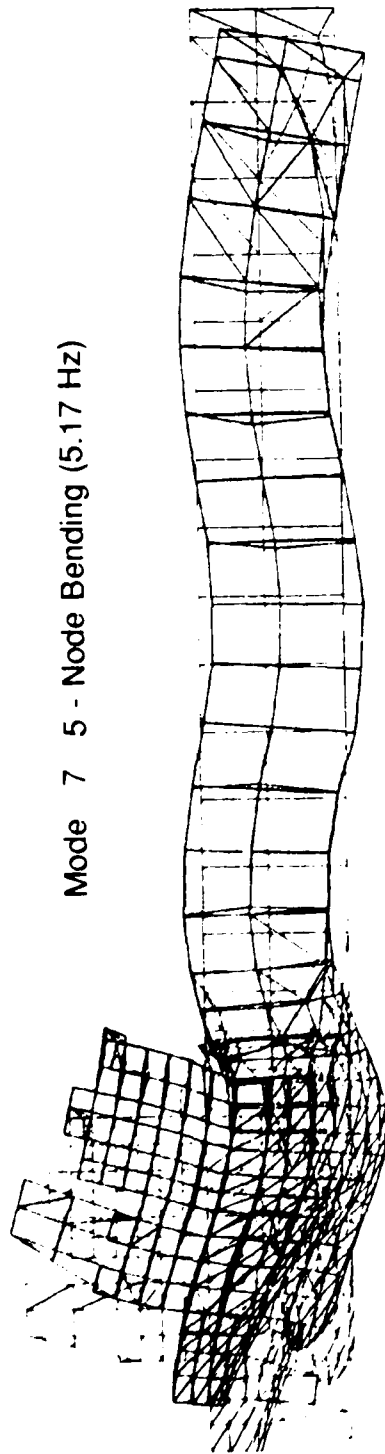

Figure 4-8
Eigenmodes in Full Load Condition

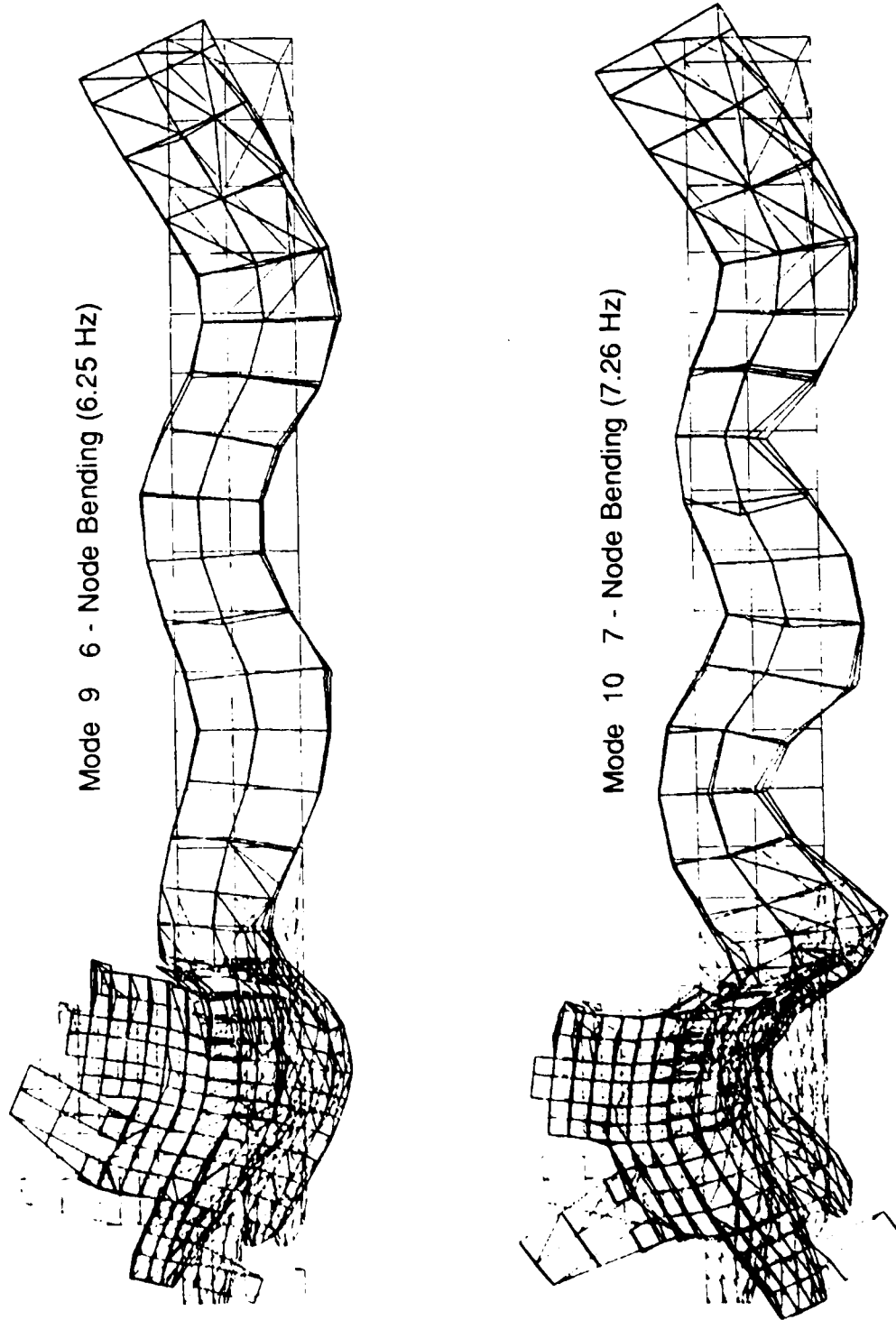

Figure 4-9
Eigenmodes in Full Load Condition

4.2.2 Empirical Calculation Procedures

A number of cases have been studied in which the previously discussed methods of calculating hull frequencies have been employed and checked against test results and against each other. This guide suggests that the most sophisticated finite-element methods of analysis are best reserved for the contract and detail design phases and that the 20-station beam analysis and the empirical method of predicting hull frequencies can be most appropriately applied in the preliminary design phase. When time and cost is an important factor, the empirical procedures given in this chapter can be effectively employed. Examples follow for a number of various ship types.

4.2.2.1 Destroyer Calculations

Preliminary design calculations were conducted on the DD 963 Class destroyer [4-18]. The 20-station beam model was used and the fundamental (two nodes) frequency was calculated to be 1.1 Hz. A simplified calculation, similar to that used by Ali [4-19] gave a frequency of 1.2 Hz. Test results indicated a frequency of 1.2 Hz. Using the original Schlick formula [4-6], and correcting for added mass of entrained water and adding a shear correction factor gave a frequency of 1.15 Hz.

4.2.2.1.1 Vertical Hull Frequencies Results of the 20-station beam analysis (conventional), the simplified beam analysis and the empirical N_{2V} frequency, multiplied by the average ratio of the higher frequencies, obtained for similar ship types included in Ref. [4-7], are shown in Table 4-1. Frequencies are in Hz, cycles/sec.

Ship Characteristics:

L	Length between Perpendiculars	525 ft
B	Beam	54 ft
D	Depth	42 ft
T	Draft	19 ft.
Δ	Displacement	7500 tons
I_V	Midship Vertical Moment of Inertia	483,000 in ² ft ²
I_H	Midship Horizontal Moment of Inertia	630,000 in ² ft ²

Schlick's Empirical Formula (Original):

$$N_{2V} = C_1 \sqrt{\frac{I}{\Delta L^3}}$$

where C_1 , a constant, = 156,850 for Destroyers

Ship Vibration Design Guide

Adjusting for entrained mass of water and adding a shear correction factor:

$$\Delta_1 = \left(1.2 + \frac{B}{3T} \right) \Delta, \text{ entrained water factor}$$

$$\sqrt{1+r} = 1.07, \text{ shear correction factor (Taylor \& Burrill [4-1])}$$

$$N_{2V} = C_1 \sqrt{\frac{I_V}{\Delta_1 \sqrt{1+r} \times L^3}} = 156,850 \sqrt{\frac{483,000}{2.147 \times 1.07 \times 7500 \times 144.7 \times 10^6}}$$

$$= 69 \text{ cpm} = 1.15 \text{ Hz}$$

Substituting BD^3 for I ,

$$N_{2V} = 54,500 \sqrt{\frac{BD^3}{2.3\Delta L^3}} = 69 \text{ cpm} = 1.15 \text{ Hz}$$

Results of the 20-station beam analysis (conventional), the simplified beam analysis and the empirical N_{2V} frequency, multiplied by the average ratio of the higher frequencies obtained for similar ship types included in reference [4-7], are shown in Table 4-1. Frequencies are shown in Hz (cycles per second).

Table 4-1 Calculated Vertical Hull Frequencies

Mode	Conventional	Simplified	Frequency Ratios	Empirical	Test Results*
2V	1.10	1.20	1.0	1.15	1.2
3V	2.24	2.50	2.15	2.47	2.4
4V	3.7	4.04	3.5	4.03	
5V	5.5	5.82	5.0	5.75	
6V	7.2	7.60	6.5	7.47	
7V	9.02	9.22	8.0	9.20	

*Obtained by anchor drop test.

Calculated Mode shapes are show in Figure 4-10, (undamped).

4.2.2.1.2 Horizontal Hull Frequencies Due to the lack of available data and the questionable reliability of using the same Schlick constant for both vertical and horizontal hull vibration, the fundamental horizontal frequency was obtained in two methods:

a) Derived from the Schlick formula

$$N_{2H} = 156,850 \sqrt{\frac{I_H}{\Delta_{1H} \sqrt{1+r} \times L^3}}$$

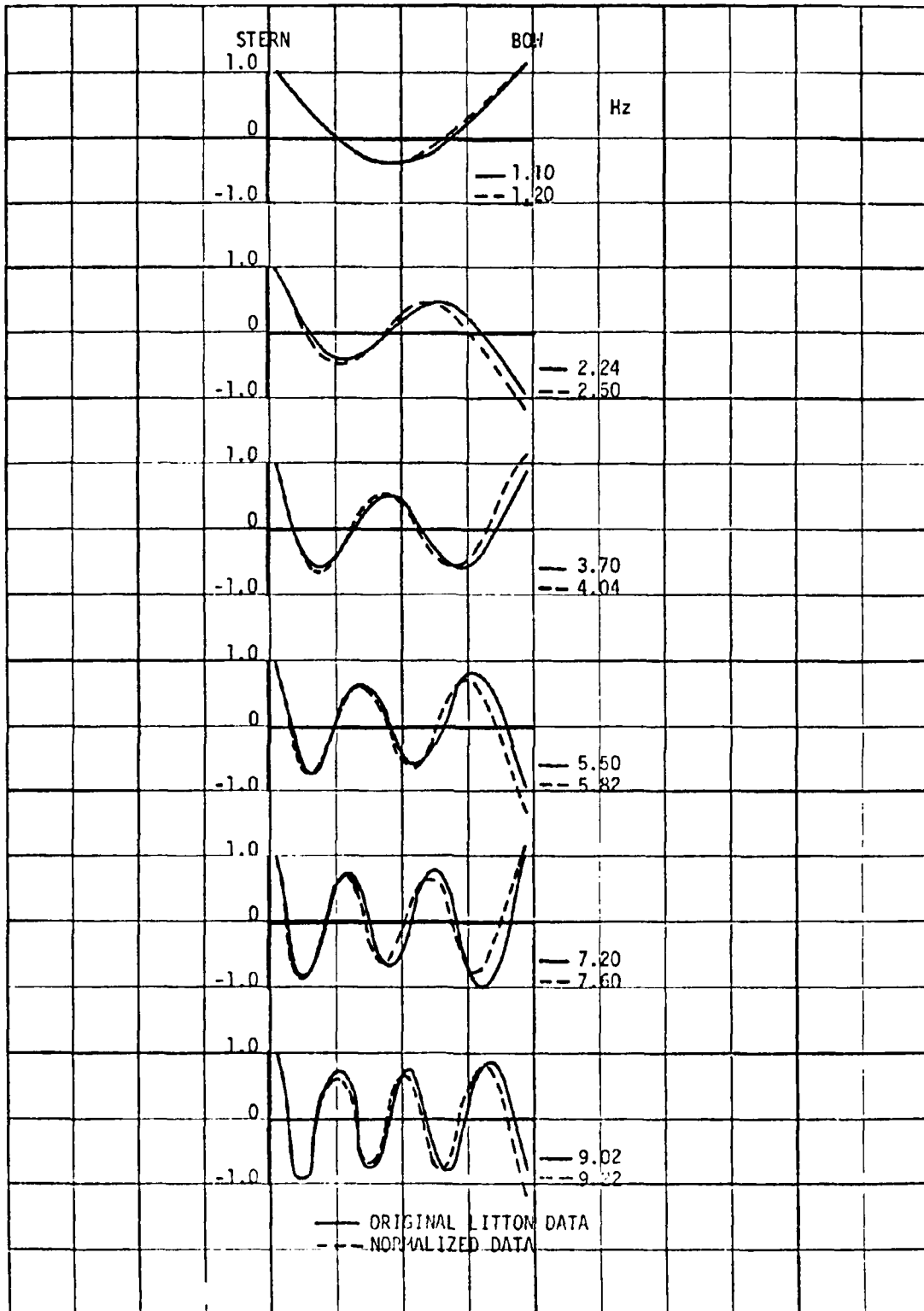

Figure 4-10
Vertical Mode Shapes

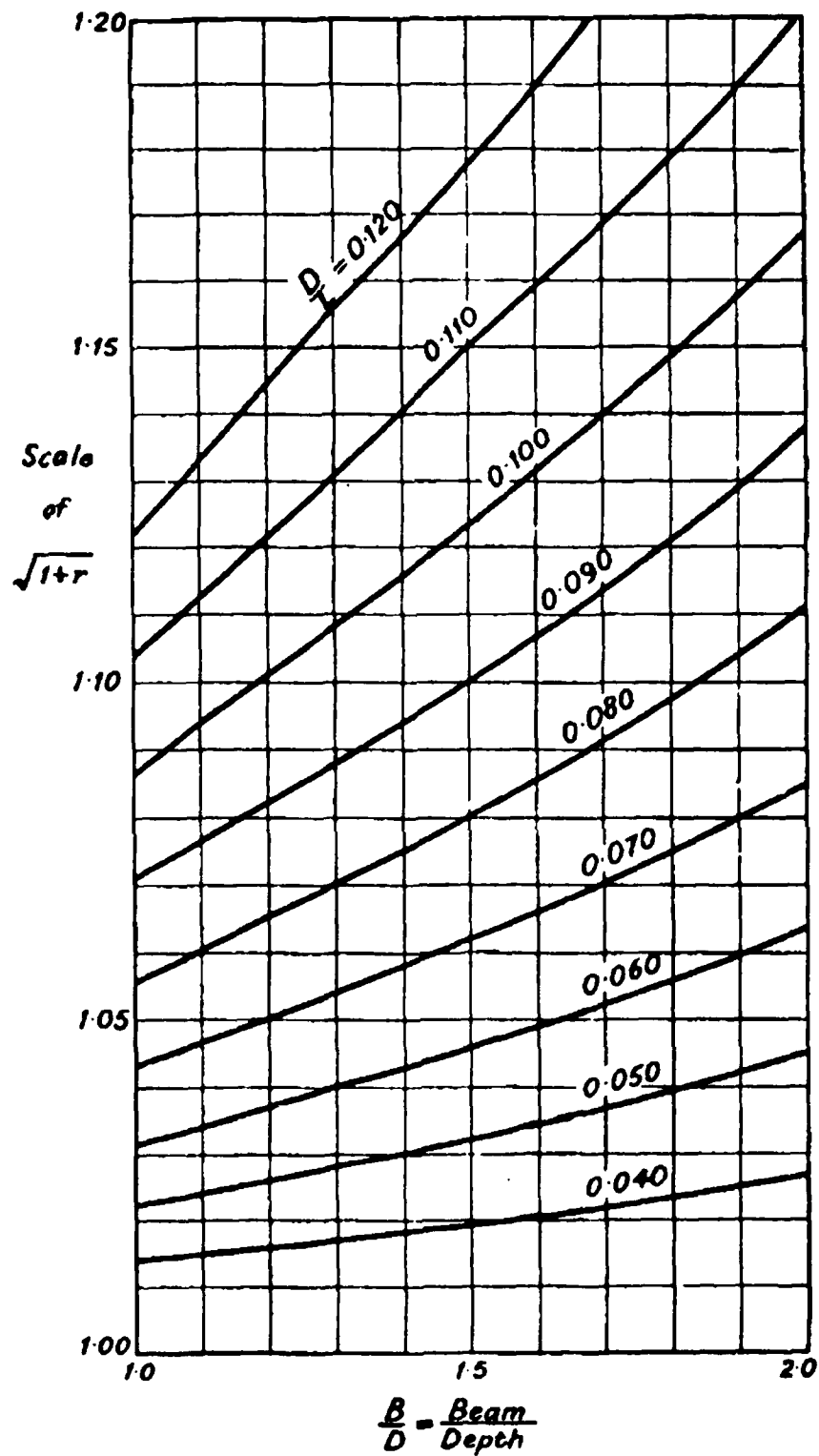

Figure 4-11
Shear Correction Factors [4-1]

$$\Delta_{1H} = \Delta + 0.0225 L d^2$$

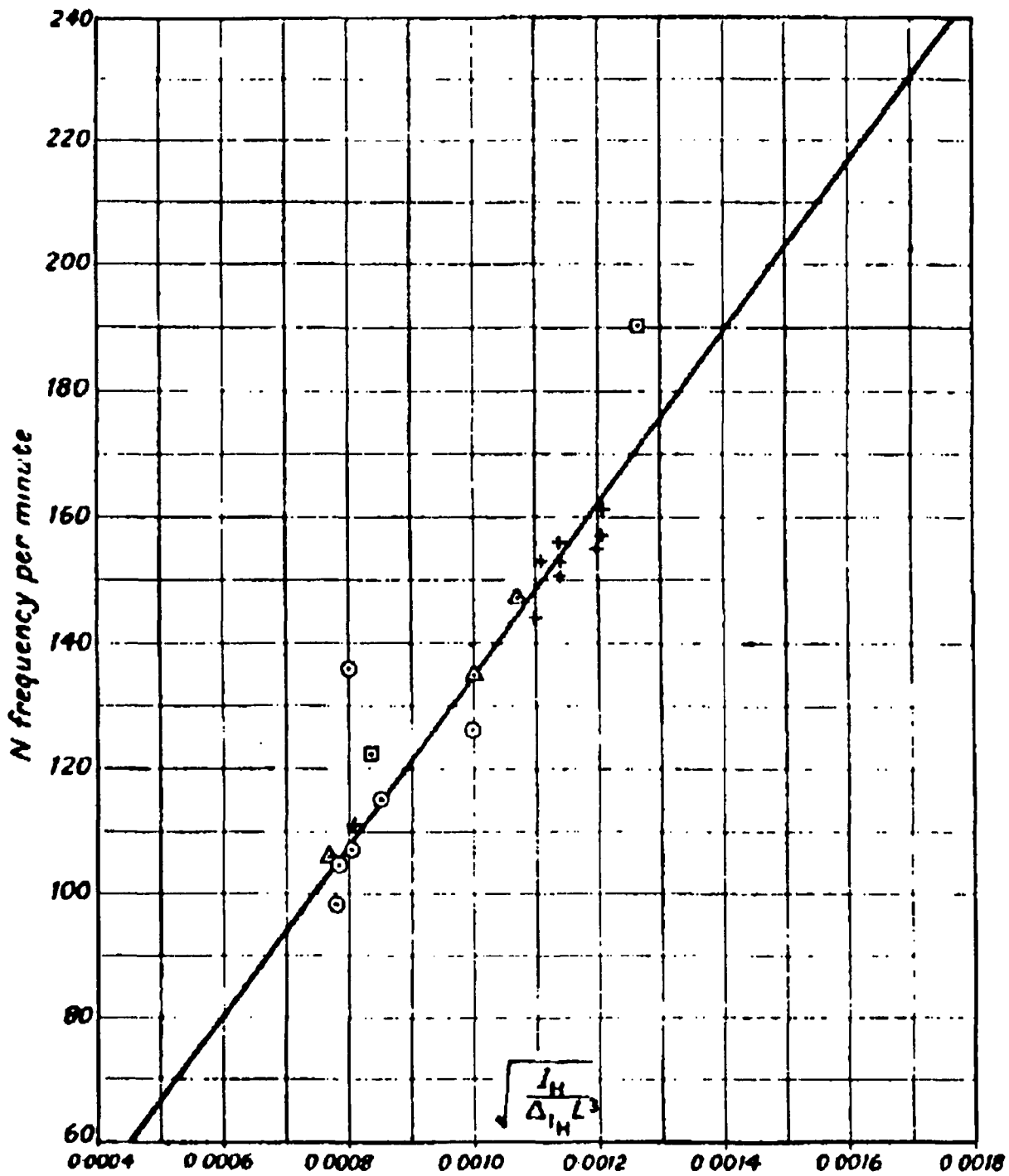

Figure 4-12

Horizontal 2 - Node Hull Frequencies [4-1]

Ship Vibration Design Guide

where::

$$\Delta_{1H} = (1.2 + \frac{T}{3B}) = 1.32 \Delta$$

with shear correction factor:

$$\sqrt{1+r} = 1.07, \text{ (see Figure 4-11)}$$

$$N_{2H} = 156,850 \sqrt{\frac{630,000}{1.41 \times 7500 \times 144.7 \times 10^6}} = 100 \text{ cpm} = 1.42 \text{ Hz}$$

b) Empirically, from Figure 4-12:

$$\sqrt{\frac{I_H}{\Delta_{1H} L^3}} = .00064 \text{ and } N_{2H} = 85 \text{ cpm} = 1.42 \text{ Hz}$$

In this instance, 1.42 Hz agrees with the conventional analysis and is confirmed by test in the third mode. This would indicate that the more appropriate horizontal C_1 would be :

$$85 / .00064 = 132,800$$

When substituting DB^3 (for Horizontal) for I_H , for N_{2H} :

$$C_1 = \frac{132,800}{\sqrt{\frac{DB^3}{I_H}}} = 41,000$$

Therefore:

$$N_{2H} = 41,000 \sqrt{\frac{42 \times 54^3}{1.41 \times 7500 \times 144.7 \times 10^6}} = 85 \text{ cpm} = 1.42 \text{ Hz}$$

Results of the 20-station beam analysis (conventional), the simplified beam analysis and the empirical N_{2H} frequency, multiplied by the higher frequency ratios of the conventional analysis, are shown in Table 4-2. The test frequency of 5.8 Hz was obtained by anchor drop test, corresponds to the third horizontal mode. This would also confirm that the 1.68 Hz fundamental frequency was too high.

Table 4-2 Calculated Horizontal Hull Frequencies

Mode	Conventional	Simplified	Frequency Ratios	Empirical	Test Results
2H	1.42	1.54	1.0	1.42	
3H	3.14	3.26	2.2	3.14	
4H	5.36	5.40	3.78	5.36	5.8*
5H	7.60	7.76	5.35	7.60	
6H	10.28	10.22	7.24	10.28	
7H	12.50	12.70	8.80	12.50	

*Obtained by anchor drop test.

Calculated mode shapes are shown in Figure 4-13, (undamped).

4.2.2.1.3 Torsional Hull Frequencies The flexure free (uncoupled) torsional frequencies and mode shapes were calculated for the DD 963, by means of an electric analog. The mass rotational inertias for the ship and virtual mass were calculated at 20 points; the torsional rigidity was calculated at stations 3,5,10,15 and 19½; and plotted with a curve faired through the points. Resonant frequencies are given in Table 4-3 and mode shapes are shown in Figure 4-14.

Horn's empirical equation [4-20] yields:

$$N_r = 1.58 \sqrt{\frac{g J_e G}{\Delta (B^2 + D^2) L}} \text{ Hz}$$

Where:

- g = gravitational acceleration = 32.2 ft / sec²
- J_e = midship torsional moment of inertia = 4260 ft⁴
- G = shear modulus = 7.71 x 10⁵ tons / ft²
- Δ = displacement = 7500 tons
- B = beam = 54 ft
- D = depth = 42 ft
- L = length = 525 ft

Horn also proposed an approximate value of J_e based on a circular cylinder:

$$J_e = \frac{4A^2}{\sum \frac{ds}{\delta}}$$

Where:

- A = enclosed area
- δ = thickness of plate
- ds = a small element along the wall enclosing the section

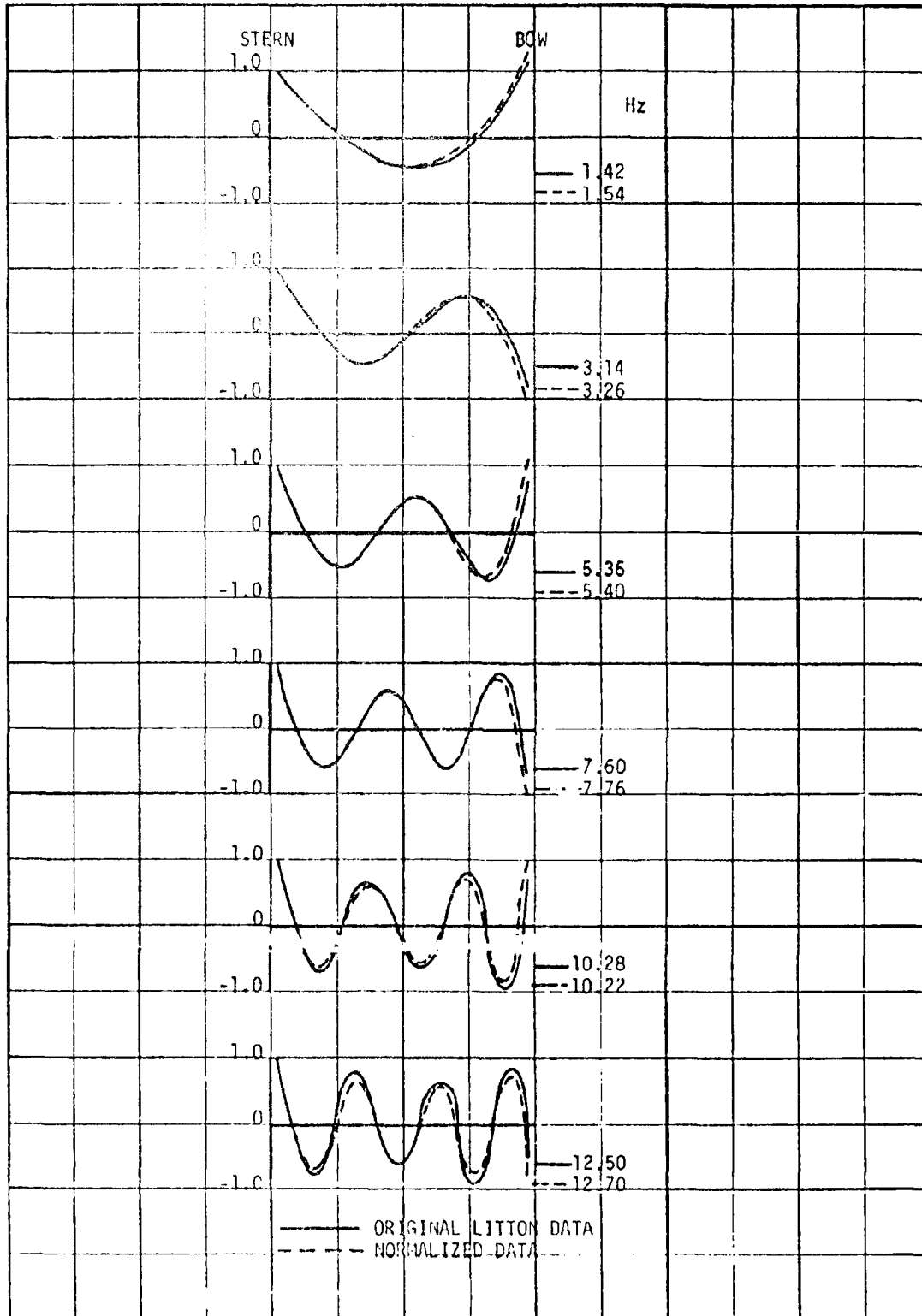

Figure 4-13
Horizontal Mode Shapes

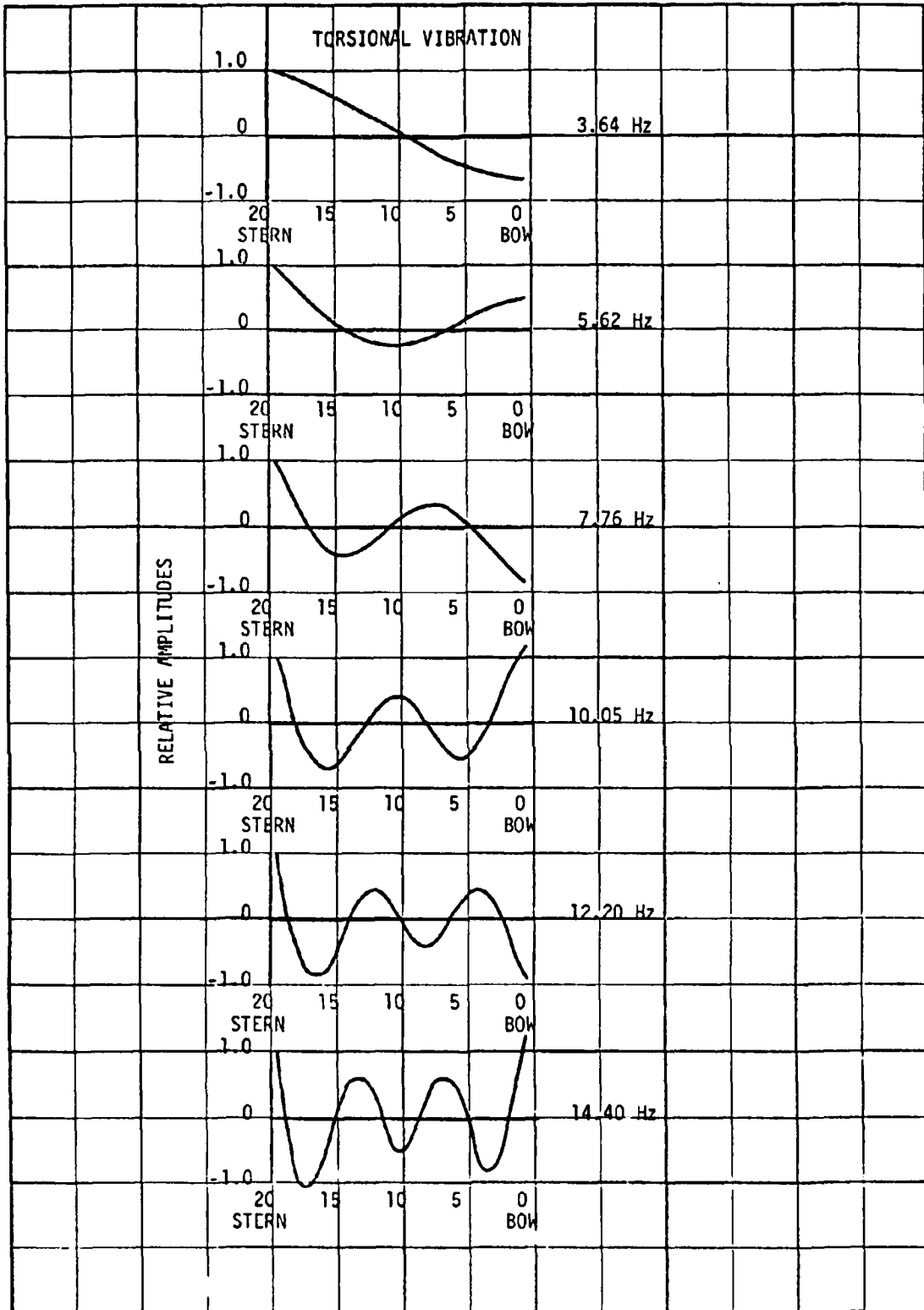

Figure 4-14
Torsional Mode Shapes

Ship Vibration Design Guide

The estimated torsional frequency is:

$$N_T = 1.58 \sqrt{\frac{32.2 \times 4260 \times 7.71 \times 10^5}{7500 (54^2 + 42^2) 525}} = 3.8 \text{ Hz}$$

Table 4-3 Calculated Torsional Hull Frequencies

Mode	Conventional Calculation	Frequency Ratios	Empirical*
1T	3.64	1.0	3.8
2T	5.62	1.54	5.86
3T	7.76	2.13	8.10
4T	10.05	2.76	10.50
5T	12.20	3.35	12.73
6T	14.40	3.96	15.03

*The same frequency ratios are used for the higher mode frequencies

No evidence of torsional hull frequencies, excited by shaft or blade-rate frequencies, was observed during ship trials. Although the one-noded torsional mode may be excited by shaft or blade-rate forces, the shaft rate is below the calculated value and the blade-rate is well above it.

4.2.2.2 LNG Calculations

The design of the LNG ships for El Paso Natural Gas Company, having an original cargo capacity of 120,000 CM; a draft limit of 36 feet; a speed of 20 knots at 80% of maximum continuous power rating; and an estimated 45,000 SHP (25% higher than previously employed in a single screw ship) presented many significant challenges including hull and machinery vibration. A preliminary study [4-21] provided a comparison of propeller force coefficients for three alternate stern configurations, identified constraints on the main propulsion system and recommended the adoption of the open transom stern configuration to minimize propeller induced vibratory forces. This work was carried out during the concept design phase.

During the preliminary design phase, wake studies were carried out on the three alternate stern configurations and estimates of alternating propeller forces were developed. Self propelled model studies were conducted on all three designs to determine speed and power requirements. Estimates of hull response to projected alternating forces were made and evaluated against recommended criteria. Preliminary analyses of the torsional and longitudinal vibration characteristics of the main propulsion system were also carried out. As a general conclusion, the report [4-22] recommended that the open transom stern configuration offered the most likelihood of meeting the total requirements for power and vibration characteristics. This configuration was used for both the *France-Dunkerque* and Newport News designs. Trial results of the first F-D hull were presented at the 1975 Ship Structures Symposium [4-5].

4.2.2.2.1 Vertical Hull Frequencies Preliminary vertical hull frequencies were calculated in 1971 by empirical methods for the proposed 120,000 CM LNG ships [4-22]. The final F-D open-transom configuration was slightly larger with a cargo capacity of 125,000 CM. A detailed 20-station beam analysis was carried out on the final configuration to provide a predicted hull response for comparison with underway vibration measurements [4-23].

Ship Particulars:		<i>France- Dunkerque</i>	<i>Avondale</i>
L_{oa}	Length overall	923	902 ft
L_{pp}	Length between perpendiculars	872.7	887 ft
B	Breadth	136.5	139 ft
D	Depth	90.25	90 ft
T	Draft	36	36 ft
Δ	Displacement, long tons	94,234	94,811 long tons
C_B	Block Coefficient	.7549	
I_V	Vertical moment of inertia	14×10^6	14.8×10^6 in ² ft ²
I_H	Horizontal moment of inertia	24×10^6	27.4×10^6 in ² ft ²

A second study was conducted on the Avondale LNG Hull [4-24], which included finite-element and 20-station beam analyses. Both ships are similar in ship characteristics except the F-D ships have built-in tanks while the Avondale hull has large trapezoidal tanks, which are installed after completion of the hull. The stern configuration differed on the two hulls. The F-D design employs an open-transom while the Avondale hull has a conventional design. Results of vertical hull frequency calculations are shown in Table 4-4.

Table 4-4 Calculated Vertical Hull Frequencies (Hz)

Mode	<i>France-Dunkerque</i>		<i>Avondale Hull</i>		Average Frequency Ratio	Empirical
	20-Station	Finite Element (Bureau Veritas)	20-Station	Finite Element (NKF)		
2V	1.00	0.8	1.05	1.08	1.0	1.03
3V	1.81	1.7	1.95	2.08	1.84	1.90
4V	2.64	2.7	2.80	3.04	2.66	2.74
5V	3.36	3.5	3.63	3.96	3.41	3.51
6V	4.08		4.40		4.14	4.26
7V	4.72		5.03	4.93	4.76	4.90
8V	5.30		5.56	5.33	5.30	5.46
9V	5.86		6.17		5.87	6.05
10V	6.39		6.81		6.44	6.63

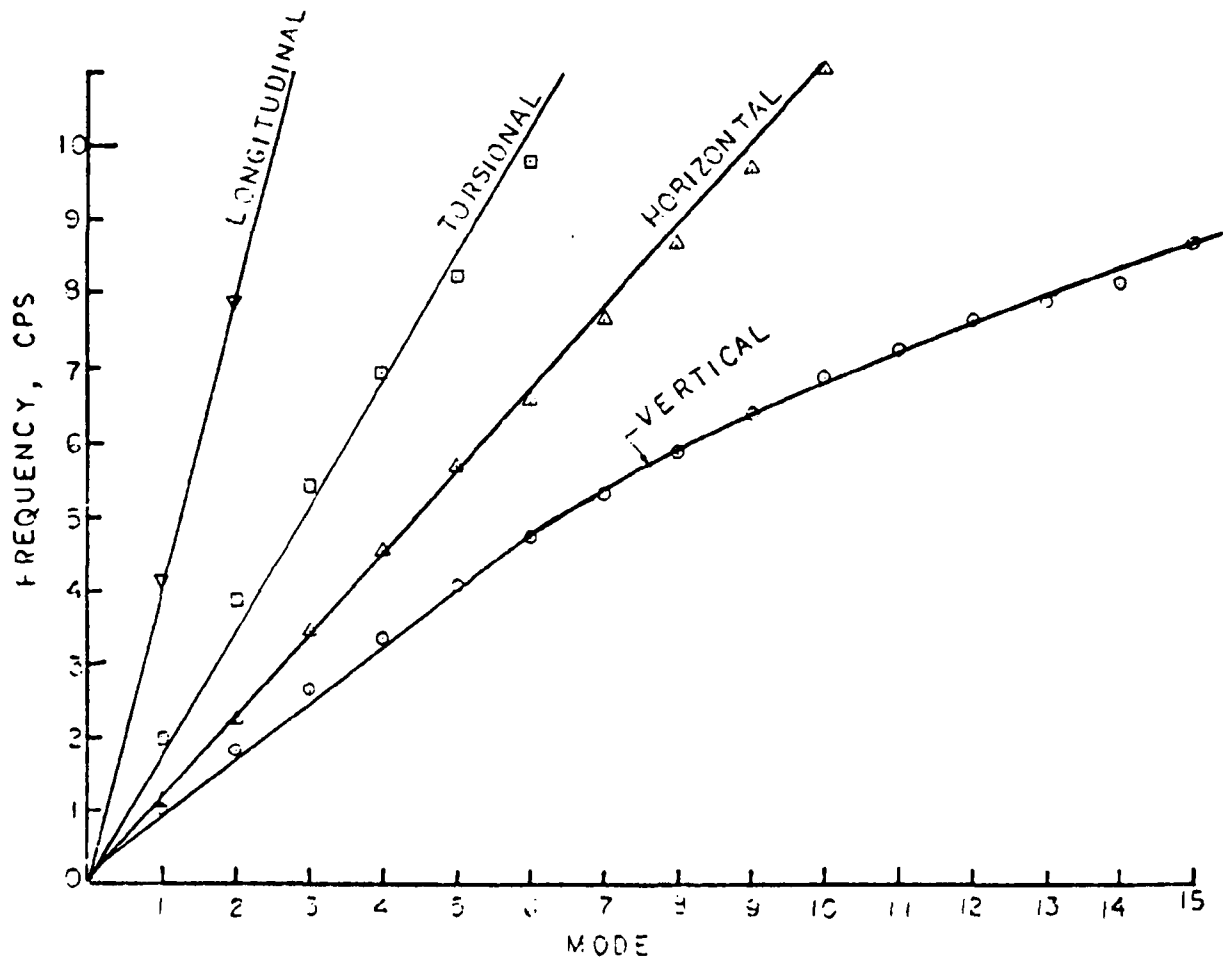

Figure 4-15

France - Dunkerque LNG Ship Hull Frequencies

Ship Hull Vibration

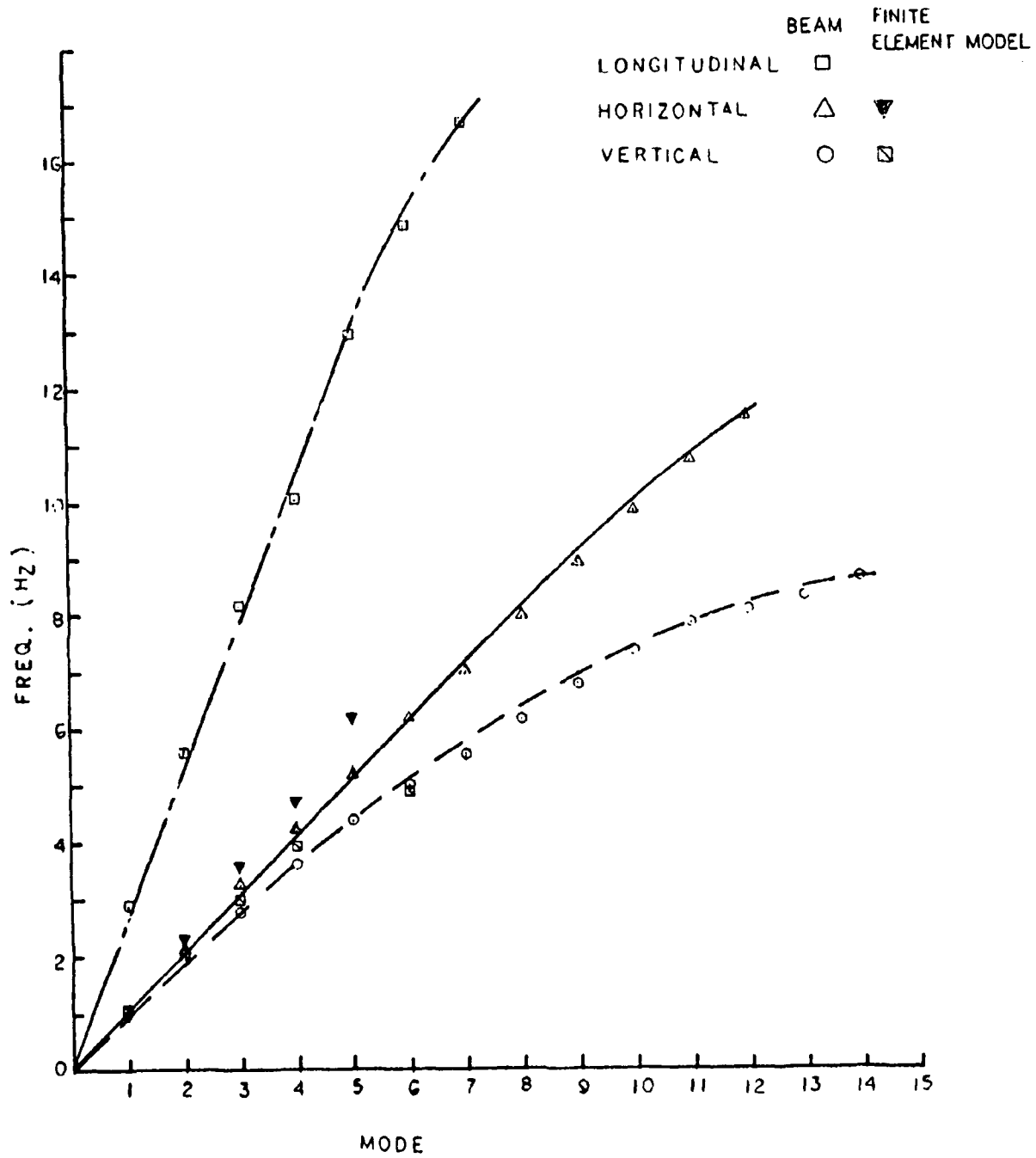

Figure 4-16
Avondale LNG Ship Hull Frequencies

Ship Vibration Design Guide

4.2.2.2 Empirical Vertical Calculation The fundamental vertical hull frequency (2V) was originally estimated during the preliminary design phase to be 1.035 Hz [4-22]. This was predicted on the basis of the original Schlick formula. A similar calculation, based on the final characteristics of the F-D hull would yield:

$$N_{2V} = 130,000 \sqrt{\frac{I}{\Delta L^3}} = 1.02 \text{ Hz}$$

However, this did not account for the entrained water nor the increase in the ship depth (D), apparently offsetting factors. The Todd formula includes a factor for the entrained mass of water and thus permits a more accurate frequency estimate for alternate load conditions. For conventional tankers the recommended formula is:

$$N_{2V} = 52,000 \sqrt{\frac{BD^3}{\Delta_1 L^3}} + 28 \text{ CPM}$$

This formula produces a fundamental hull frequency of 1.16 Hz, which is estimated to be about 12% too high for this type of hull, based on the detailed analyses conducted. Although the fundamental modes were not identified during trials, evidence of the eighth vertical mode (9V) at 5.83 Hz (vs. 5.86 Hz for the F-D calculation) was noted during shaker tests conducted on the *El Paso Sonatrach*.

The horizontal modes (6H, 7H and 9H) were also noted at 5.5, 6.56 and 8.66 Hz, respectively, indicating the 20-station F-D calculations shown in Tables 4-4 & 4-5, are correct.¹ Adjusting the coefficients to the special LNG case, we obtain:

$$N_{2V} = 46,000 \sqrt{\frac{BD^3}{\Delta_1 L^3}} + 25 \text{ CPM}$$

This yields approximately 1.03 Hz for the F-D hull and 1.02 Hz for the Avondale hull. The 20-station beam calculations would be 3.4% low for the F-D hull and 3% high for the Avondale hull. The frequencies shown in the empirical column of Table 4-4 were generated by multiplying the fundamental frequency of 1.03 Hz by the average frequency ratios obtained from both 20-station calculations.

4.2.2.2.3 Horizontal Hull Frequencies When making preliminary estimates during the concept or preliminary design phases, the fundamental horizontal hull frequency has been generally estimated to be 140% to 150% that of the fundamental vertical hull frequency, as may be noted from Figures 4-17 and 4-18. This estimate is normally satisfactory since the vertical

1 A light weight mechanical shaker was used at sea with the ship dead in the water to explore the response of the hull in the upper blade-frequency range and to identify the presence of local resonances, if any. Due to the limitation of forces generated at low frequencies, only resonances above 5 to 6 Hz could be identified.

*Suggested lines are shown
for estimating purposes*

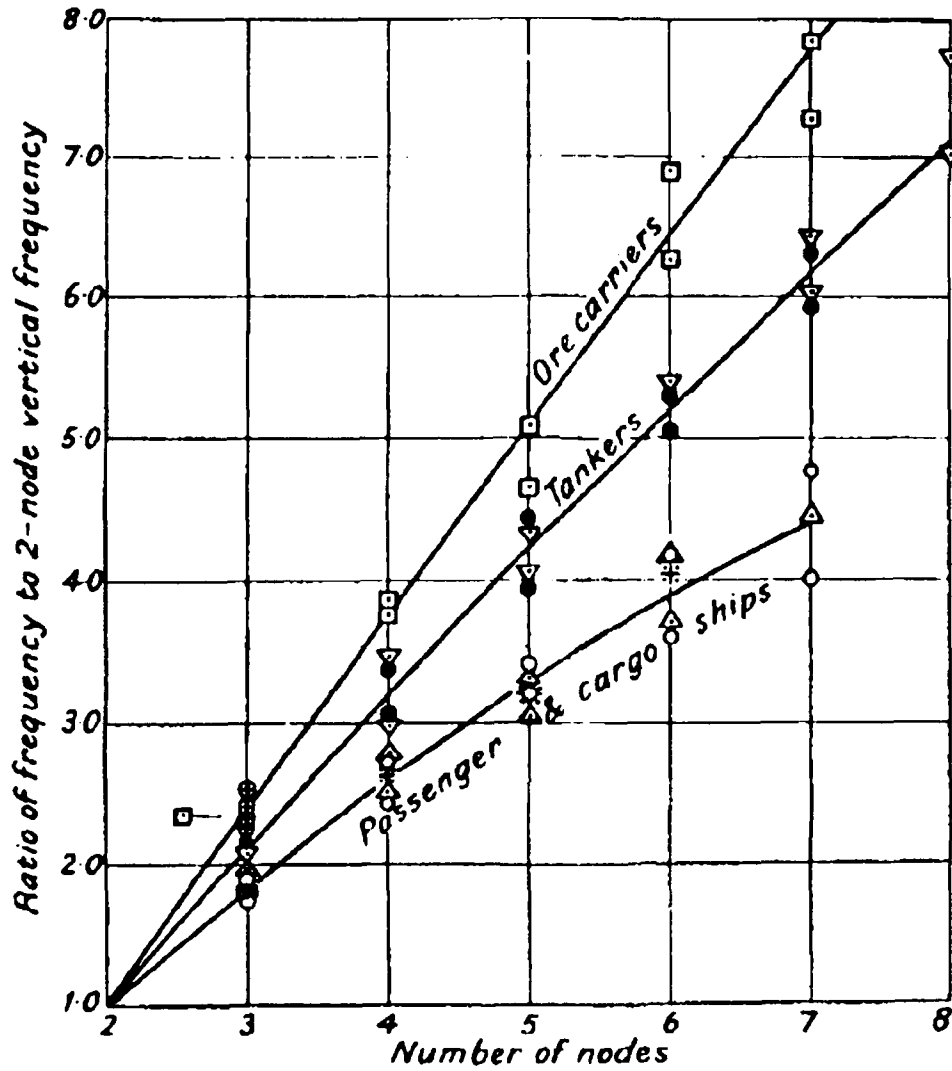

- Cargo ships (Todd)
- Johnson & Ayling - limits for Tankers
- Johnson & Ayling - limits for Passenger & Cargo ships
- ✱ Cargo ships } T.M.B. Report 906
- Ore carriers }
- △ "Mariner" class cargo ship (SNAME, 1955)
- ▽ 42,000 tons dwt. tanker (Kumai)

Figure 4-17

Higher Frequency Ratios, Vertical Vibration [4-1]

*Suggested lines are shown
for estimating purposes*

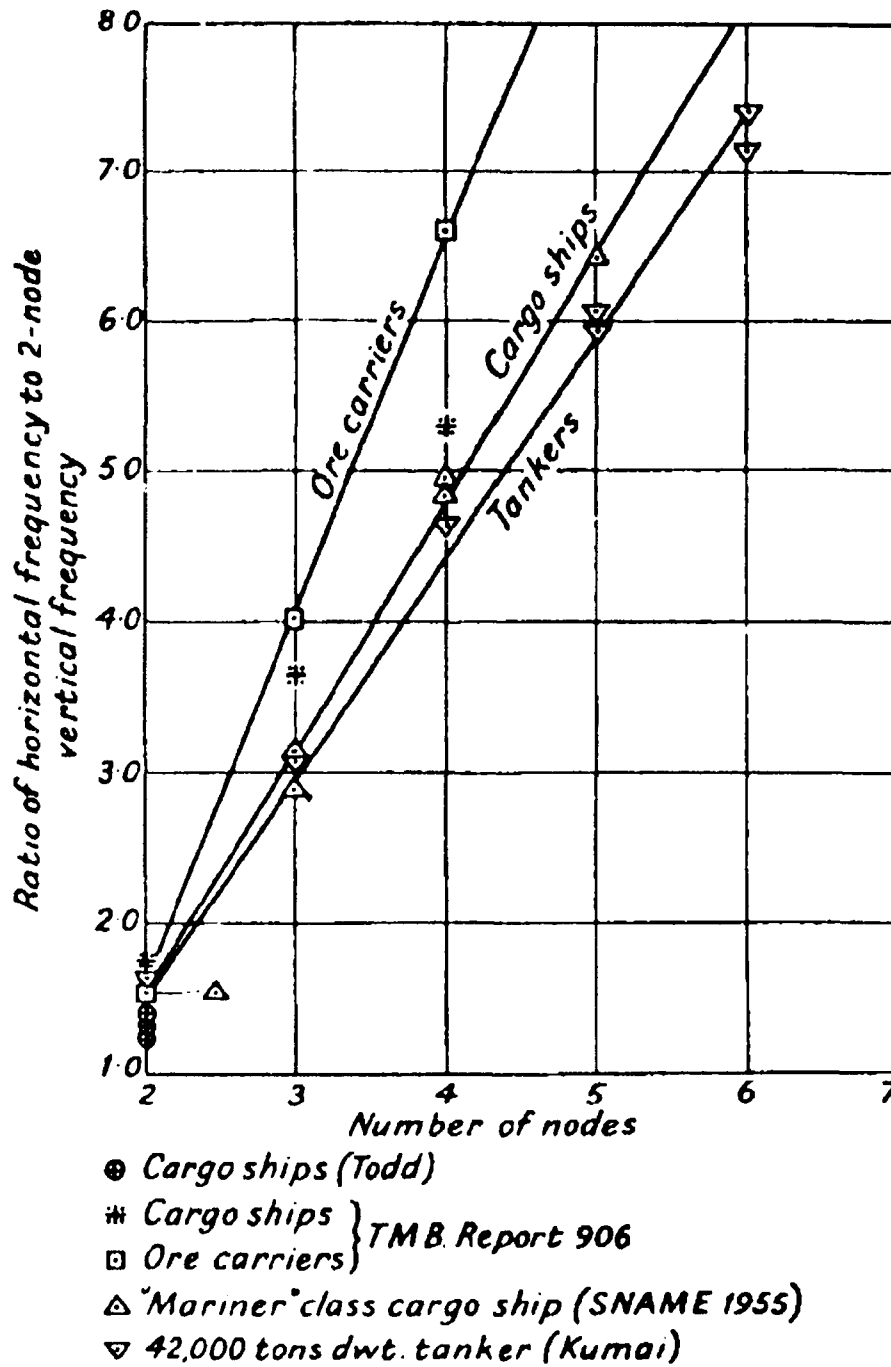

Figure 4-18

Higher Frequency Ratios, Horizontal Vibration [4-1]

hull response is much more important. The data base is not as great for horizontal modes and ship details are not sufficiently firm to make adequately accurate calculations.

Relying on the more accurate 20-station F-D calculations, which have been confirmed by shaker test, the fundamental horizontal frequency is 1.09 Hz, or about 9% higher than the corresponding fundamental vertical frequency. Calculated results for both hulls are shown in Table 4-5.

4.2.2.2.4 Empirical Horizontal Calculations Referring to Figure 4-12, the estimate for N_{2H} would be approximately 1.25 Hz, assuming the general characteristics are proportional to the average ship.

However, as previously noted, the fundamental vertical frequency calculates to be about 12% high and it is expected that the horizontal frequency would also be high. In that case, if the estimated horizontal frequency is reduced by a like amount, the 1.25 Hz would be 1.10 Hz, compared to the value of 1.09 Hz.

Table 4-5 Calculated Horizontal Hull Frequencies,(Hz).

Mode	France-Dunkerque		Avondale	Average Frequency Ratio	Shaker Test Results
	20-Station	Frequency Ratio	20-Station		
2H	1.09	1.00	1.0	1.00	
3H	2.21	2.03	2.15	2.09	
4H	3.44	3.15	3.28	3.22	
5H	4.53	4.16	4.23	4.20	
6H	5.69	5.22	5.21	5.22	5.50*
7H	6.55	6.01	6.19	6.10	6.56
8H	7.65	7.02	7.00	7.01	
9H	8.65	7.94	7.98	7.96	8.66
10H	9.57	8.78	8.93	8.85	

* Also noted during underway runs on F-D Trials.

Another approach, suggested by Brown [4-25] and reported by Todd:

$$N_{2V} = \beta_V \sqrt{\frac{BD^3}{\Delta VL^3}} \text{ CPM}$$

and:

$$N_{2H} = \beta_H \sqrt{\frac{DB^3}{\Delta VL^3}} \text{ CPM}$$

Ship Vibration Design Guide

where: N_{2V} and N_{2H} are 2-node frequencies of vertical and horizontal vibration.

β_V = vertical coefficient

β_H = horizontal coefficient

B = beam molded

L = length between perpendiculars

D = depth molded

Δ = displacement

V = virtual weight factor, $(1.2 + \frac{B}{3T}) = 2.46$ or $(1.2 + \frac{T}{3B}) = 1.29$

for vertical and horizontal modes, respectively

For the F-D design, assuming the calculated $N_V = 1.0$ Hz and $N_H = 1.09$ Hz, $\beta_V = 74,700$ and $\beta_H = 39,200$. Additional values for different ship types, have been given by Brown and are repeated by Todd [4-1].

It should be noted that the 20-station beam analysis for the F-D hull, gave $N_V = 1.0$ Hz and $N_H = 1.09$ Hz (9% higher), while the same calculation on the Avondale hull gave $N_V = 1.05$ Hz and $N_H = 1.00$ Hz (5% lower). The F-D design is conventional in that the tanks are built-in. The Avondale design has voids arranged in the hull to receive trapezoidal tanks, which apparently reduce the horizontal hull stiffness. A significant departure from the generally standardized design concepts requires more refined calculations than the empirical estimates during the preliminary and/or detailed design phase.

4.2.2.3 Current Hull Designs

Sections 4.2.2.1 and 4.2.2.2 provided hull frequency studies for a Destroyer and a large LNG Carrier. Both ships represented unique, high powered designs which were sufficiently well studied to ensure, in so far as possible, that they were free from objectionable vibration. Data was available to make vibration predictions yielding vibration specifications and provided a basis for judgment on the applicability of relatively simple methods of empirical analysis in the conceptual and preliminary design phase of shipbuilding. Both ships were successful with regard to their vibration characteristics. Results of full-scale ship trials were reported at the 1975 Ship Structures Symposium [4-5].

In this section, the application of empirical hull frequency determination is evaluated against current designs on which ship data is available. Of primary consideration at this time are recent Product Carrier/Tanker designs with machinery aft. Modifications to empirical coefficients are made to reflect current requirements.

4.2.2.3.1 Vertical Hull Frequencies For preliminary estimates the original Schlick formula is used. A range of coefficients, from 127,000 for cargo ships with full lines, to 156,850 for ships with very fine lines, was suggested. In 1960 Todd suggested 130,000 for large tankers, fully

loaded and 100,000 for small, trunk-deck coastal tankers, 300-350 ft. in length, fully loaded. The experience of the author suggested the value of 130,000 for tankers was low. Thus, for the 1982 Baseline Review of the T-AO-187 [4-26], this constant was increased by 10%, to 143,000. The two T-AO hulls and a recent (1987) Product Carrier give the following results:

$$N_{2V} = C \sqrt{\frac{I}{\Delta L^3}} \text{ CPM with } C = 143,000$$

For I:

$$C \sqrt{\frac{1,767,385}{40,000 \times 633^3}} = 143,000 \times .4174 \times 10^{-3} = 59.69 \text{ CPM} = .995 \text{ Hz}$$

For II:

$$C \sqrt{\frac{1,656,000}{40,600 \times 650^3}} = 143,000 \times .3883 \times 10^{-3} = 55.52 \text{ CPM} = .925 \text{ Hz}$$

For III:

$$C \sqrt{\frac{1,691,163}{49,884 \times 554.5^3}} = 143,000 \times .4459 \times 10^{-3} = 63.76 \text{ CPM} = 1.06 \text{ Hz}$$

With this constant, the N_{2V} frequencies of II and III fall within 4% of the test results obtained on the T-AO and with the FEM analysis conducted on the Product Carrier, as shown on Figures 4-6 through 4-9. Although this is recognized as a small sample, it indicates that for similar ship types built to classification society requirements, such preliminary estimates can be very useful in the concept and preliminary design phases.

<u>Ship Characteristics:</u>	I Baseline	II As Built	III Product
	T-AO-187	T-AO-187	Carrier
L Length Between Perpendiculars	633	650	554.5 ft
B Beam	93.5	97.5	105.6 ft
D Depth	50	50	56.75 ft
T Draft	35	37.83	36.75 ft
Δ Displacement	40,000	40,600	49,884 long tons
L/B Length-Beam Ratio	6.77	6.67	5.5
B/T Beam-Draft Ratio	2.67	2.58	2.87
C Block Coefficient	.662		.7934
I_V Midship Area Mom. of Inertia	1767,385	1,656,000	1,691,163 in ² ft ²
Number of Shafts	2	2	1

Ship Vibration Design Guide

4.2.2.3.2 Recommended Empirical Hull Vertical Frequency Coefficients Following his 1960 review of past research on hull frequency determinations, Todd proposed a modification of the Schlick formula that permits the use of ship dimensions and the determination of hull frequencies for different load conditions. The empirical coefficients would be expected to vary when modifications to the classification society rules are introduced. As originally drafted, the Todd formula was written, as follows:

$$N_{2V} = C_1 \sqrt{\frac{BD^3}{\Delta_1 L^3}} + C_2 \text{ CPM}$$

where:

$$C_1 = 52,000 \text{ and } C_2 = 28, \text{ for Tankers}$$

$$C_1 = 46,750 \text{ and } C_2 = 25, \text{ for Cargo and Passenger Ships}$$

$$\Delta_1 = \left(1.2 + \frac{B}{3T}\right) \Delta$$

Applying the Todd formula to the above two tankers built:

$$\text{II (FL)} \quad 52,000 \times .7285 \times 10^{-3} + 28 = 65.88 \text{ CPM} = 1.1 \text{ Hz vs. } .95 \text{ Hz by Test.}$$

$$\text{III (FL)} \quad 52,000 \times 1.025 \times 10^{-3} + 28 = 81.30 \text{ CPM} = 1.36 \text{ Hz vs. } 1.14 \text{ Hz by FEM.}$$

$$\text{III (BAL)} \quad 52,000 \times 1.237 \times 10^{-3} + 28 = 92.32 \text{ CPM} = 1.54 \text{ Hz vs. } 1.34 \text{ Hz by FEM.}$$

The results indicate the proposed coefficients, derived from ships built prior to 1960, may not reflect current classification society rules. By adjusting C_1 to 45,000 and C_2 to 25 for these ships:

$$\text{II (FL)} = .96 \text{ Hz vs. } .95 \text{ Hz by Test.}$$

$$\text{III (FL)} = 1.19 \text{ Hz vs. } 1.14 \text{ Hz by FEM.}$$

$$\text{III (BAL)} = 1.34 \text{ Hz vs. } 1.34 \text{ Hz by FEM (1.3 observed by Test).}$$

The higher frequency estimates are based on the estimated fundamental frequency multiplied by the known higher frequency ratios obtained for ships of the same category. Results for this limited group are shown in Table 4-6.

Table 4-6 Estimated Vertical Hull Frequencies (Hz)

Mode	Ship II		Ship III		Average Ratios	Estimated Frequencies (FL)	
	Test	Ratios	Predicted	Ratios		Ship II	Ship III
2V	.95	1.0	1.14	1.0	1.0	.96	1.19
3V	1.99	2.09	2.32	2.04	2.06	1.98	2.45
4V	3.09	3.25	3.72	3.30	3.27	3.14	3.89
5V	4.18	4.40	5.17	4.50	4.45	4.27	5.30
6V	4.84	5.09	6.25	5.5	5.30	5.09	6.31
7V			7.26	6.4	6.4	6.14	7.60

It may also be noted that the frequency ratios follow very closely the curve for Tankers, shown on Figure 4-17. The following formula is also frequently used for estimating the higher modes:

$$N_{nV} = N_{2V} (n-1) \mu_V$$

Where: $\mu_V = 1.02$ for Tankers, 1.0 for Bulk Carriers and 0.85 for Cargo Ships. However, for the above ships, a value of 1.05 for Tankers would be more appropriate. When available, the actual frequency ratios obtained for a given ship type, should be used. Supplemental data prepared by ABS, which address recommended empirical hull frequency coefficients, is given in Appendix 4-A. It should be noted that the super tanker example represents a special case.

4.2.2.3.3 Horizontal Hull Frequencies The fundamental horizontal hull frequency is estimated at 1.5 times the estimated vertical frequency ($1.5 \times .95 = 1.44$ for Ship II) for preliminary design purposes, although the actual factor in this instance is approximately 1.65, as determined by test results. Additional ship data may indicate an adjustment to this factor. The estimated horizontal hull frequencies are shown in Table 4-7 for Hull II on which test data is reported. Alternate higher frequency ratios are shown, for comparison purposes.

Table 4-7 Estimated Horizontal Hull Frequencies Ship II (Hz)

Mode	Test*	Ratios	Higher Frequency Ratios				
			Test Ratios	Average Ratios from Table 4-6	From Figure 4-18	$\mu = 1.02$	$\mu = 1.05$
2H	1.58	1.0	1.44	1.44	1.44	1.44	1.44
3H	3.35	2.12	3.05	2.97	2.90	2.94	3.02
4H	4.90	3.10	4.46	4.71	4.32	4.41	4.54
5H	6.60	4.18	6.02	6.41	5.76	5.87	6.05
6H					7.10	7.34	7.56

* Note that the test frequencies shown are 10% higher than the estimated value shown.

4.2.2.4 Examples of Other Ship Types

Based on currently available data, several different ship types are evaluated by comparing empirical calculations against the more extensive beam or FEM analysis and where available, against test results. Although significant differences exist in the ships, the correlation indicates the validity of the empirical approach in preliminary design. With the development of a suitable data base, more accurate preliminary hull estimates can be readily made. The characteristics of these additional ships are:

Ship Vibration Design Guide

Ship Characteristics	Mariner	Container	RORO	Icebreaker
L_{BP} Length, ft.	528	644.69	547.9	352
B Breadth, ft.	76	105.77	89.99	78
D Depth, ft.	44.5	61.68	54.13	53
T Draft, ft.	27	23.19	29.95	30
Δ Displacement, Lt.	18,647	27,218	29,753	12,100
Δ_1 Displacement + Entrained water	39,872	74,042	65,502	25,007
I_V Area Moment of Inertia, in ² ft ²	1,123,200			1.7×10^6
I_H Area Moment of Inertia, in ² ft ²				4.15×10^6

Table 4-8 Examples of Hull Frequencies for Other Ship Types

Mode	Mariner Class, Cargo (Prior to 1960)				Container Ship (Recent)			Icebreaker [4-11]			RORO Ship (Recent)	
	Beam Calc	Meas	Schlick	Todd	Beam Calc	Meas	Todd	Beam Calc	Meas	Schlick	FEM Calc	Todd
See note number:			1	2			3		4	1		3 & 5
2V	1.22	1.37	1.36	1.25	1.00	1.03	1.08	3.10	3.30	3.84	1.09	1.10
3V	2.48	2.58	2.52	2.31	1.96	2.05	2.00	6.70	6.60	7.10	2.31	2.31
4V	3.88	3.78	3.54	3.25	2.83	2.93	2.81	10.10	9.60	9.98	3.66	3.47
5V	5.30	4.50	4.49	4.13	3.69	3.67	3.56	13.40	13.50	12.67	4.90	4.62
6V					4.09	4.30	4.21	16.70	16.80	14.95		
2H	1.78	1.97	2.04	1.88	1.28	1.37	1.40*	5.60	4.95	5.76		
3H	3.90	4.67	4.22	3.88	2.34	2.84	2.38	10.50	9.90	11.52		
4H	6.15	5.83	6.53	6.00	3.45	3.86	3.57	15.20	14.85	17.28		
5H			8.70	8.00				19.70	19.80	23.04		
6H								24.20	24.75	28.80		

* $N_{2H} = 1.3 \times N_{2V}$ and μ is assumed to be .85

Notes:

1 Original Schlick, $N_{2V} = 127,900 \sqrt{\frac{I}{\Delta L^3}}$, Higher Frequency Ratios, Figures 4-17 and 4-18

2 Todd, $N_{2V} = 46,750 \sqrt{\frac{BD^3}{\Delta_1 L^3}} + 25$ HFR from Fig. 4-17 and 4-18

3 Todd with revised coefficients $C_1 = 40,000$ and $C_2 = 20$, HFR Fig.4-17

4 Todd with coefficients $C_1 = 52,000$ and $C_2 = 28$, $N_{2H} = 1.5 \times N_{2V}$ and $\mu = 1$

5 $\mu = 1.05$ is assumed for HFR

4.3 Preliminary Hull Response Analysis

It has been stated earlier, that the major steps to be taken to avoid hull vibration include the minimization of the exciting forces and the avoidance of structural resonances. Propeller forces were covered in Chapter Three and the prediction of hull frequencies was treated earlier in this chapter. At this point, the application of estimated vibratory forces to the mass-elastic systems of the hull and main propulsion system is addressed. Additionally, an estimate, or calculation for the dynamic response of these systems against the criteria recommended in Chapter Two is presented. For convenience, in this chapter, the primary emphasis is placed on the hull response with the recognition that final decisions on propeller type, number of propeller blades, location and type of main engines, shaft dimensions and RPM will have a very significant impact on many related variables. These facts emphasize the necessity of evaluating the vibration characteristics of the hull and main propulsion machinery system in the concept and preliminary design phases of any shipbuilding program, if possible prohibitive ship or machinery modifications are to be avoided.

The earlier sections of this chapter have indicated from the examples shown that while the most important hull frequencies can be determined by finite element or beam analysis (at considerable expense and loss of time), empirical estimates can be readily made during the concept design phase at little expense and with equivalent reliability, given a reasonable data base. This approach is recommended since potential conflicts with initially proposed propulsion system characteristics can be identified before machinery orders are placed. During the preliminary design phase, the beam model and/or the FEM analysis can provide confirmation of hull frequencies and estimates of hull response.

While the total preliminary vibration design analysis includes both hull and main propulsion machinery, this section covers the hull portion and Chapter Five covers machinery. Most decisions will be based on the integrated evaluation of both system studies. The following subtopics are included in this section:

- Avoiding Hull Resonance
- Forced Hull Response
- Resonant Hull Response

4.3.1 Avoiding Hull Resonance

Having established estimated hull frequencies, a plot of hull frequency vs. shaft RPM for the vertical, horizontal and torsional (if required) modes will permit a ready evaluation of anticipated resonances. Figure 4-19, taken from the Icebreaker study [4-11], shows the range of vertical, horizontal and torsional frequencies, from light to full load for full speed and bollard conditions with four- and five-bladed propellers. Such a display will assist greatly in the selection of the number of propeller blades, location of the engines and operating RPM. For most commercial vessels that employ direct drive operating at low RPM, the addition of first and second order lines on the graph will identify possible resonances with first and second order moments introduced by the engine. This will have a direct bearing on the selection of the engine and the safe operating RPM.

Ship Vibration Design Guide

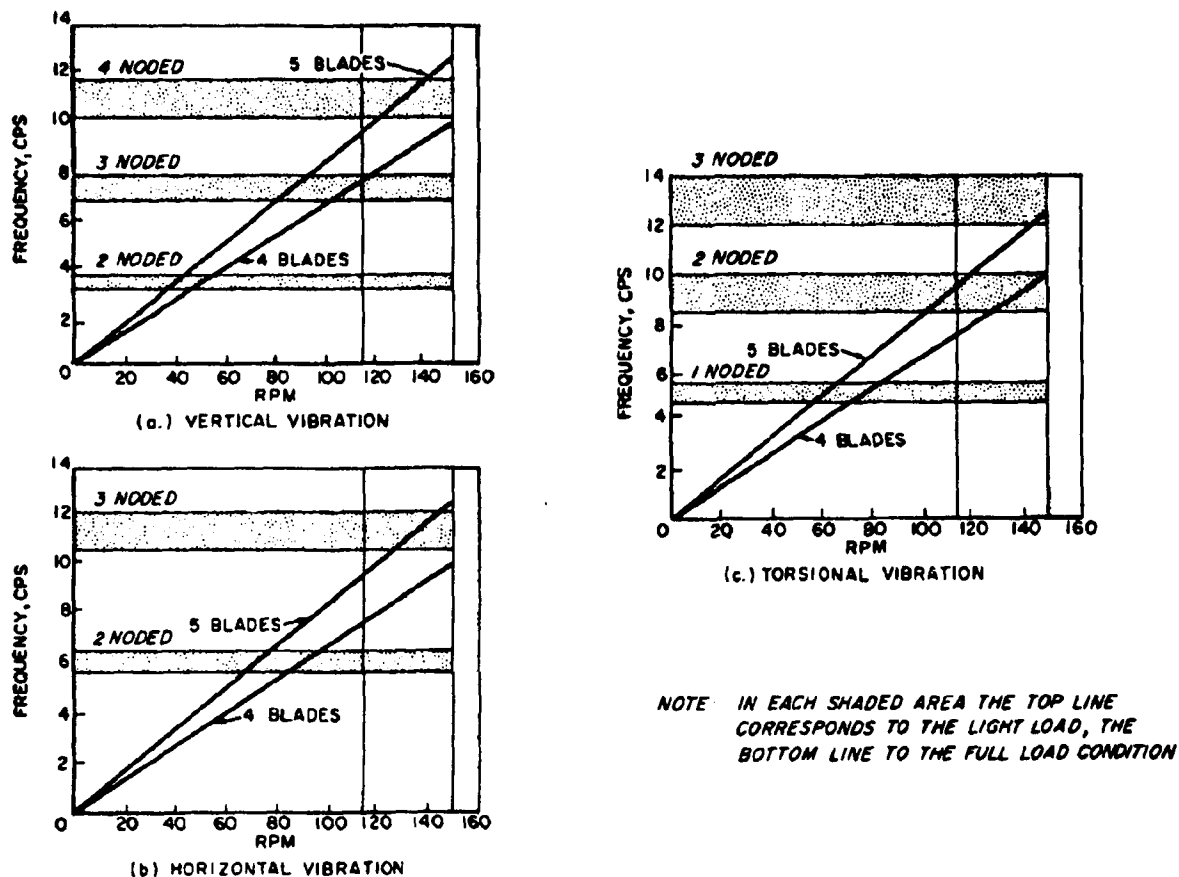

Figure 4-19

Range of Vertical, Horizontal and Torsional Frequencies from Light to Full Load Compared with 4 - Bladed or 5 - Bladed Propeller Frequencies

First order forces emanating from dynamic unbalance or misalignment in the propulsion system, or hydrodynamic unbalance (damage or out of pitch) of propellers, can produce a strong response if resonant with a vertical or horizontal hull frequency. Although these forces can be readily limited to acceptable levels by adhering to the recommended tolerances previously noted, it is strongly recommended that the shaft RPM be selected so as to avoid resonance at normal operating speeds, providing of course, that this choice is consistent with the requirements of blade frequencies.

It was pointed out in Chapter Two that in the low-frequency range below 5 Hz, the ISO criteria changes from constant velocity to constant acceleration. This is considered necessary to compensate for the effects of engine unbalance encountered with large, low-speed, direct-drive diesel engines. The lower constant velocity limits were recommended for turbine driven ships.

Low-speed, direct-drive diesels will generally develop strong first and second order moments, which can produce serious hull vibration if resonant with the lower hull frequencies. To provide a realistic evaluation of engine-hull response to the unbalanced forces and moments

introduced by the engine, the manufacturer should provide this information that can be included in the vibration analysis. The engine input forces and operating speed, when considered with the predicted hull frequencies should be used in the selection of the engine. An example of the input moments are shown in Figure 4-20, taken from Reference [4-27]. This reference also shows the estimated hull response on a container ship, which employs a low-speed engine with shaft speed in the vicinity of the lower vertical hull modes.

The fore and aft location of large, slow-speed diesels can also be an important factor in hull response. Using the nodal points for the lower vertical and horizontal hull modes from mode shape diagrams, Figures 4-11 and 4-13 can be used for spotting the engine to minimize the influence of generated unbalanced forces and moments. Unbalanced forces have the maximum influence at the anti-node position and unbalanced moments are most effective when the engine is centered at the nodal point.

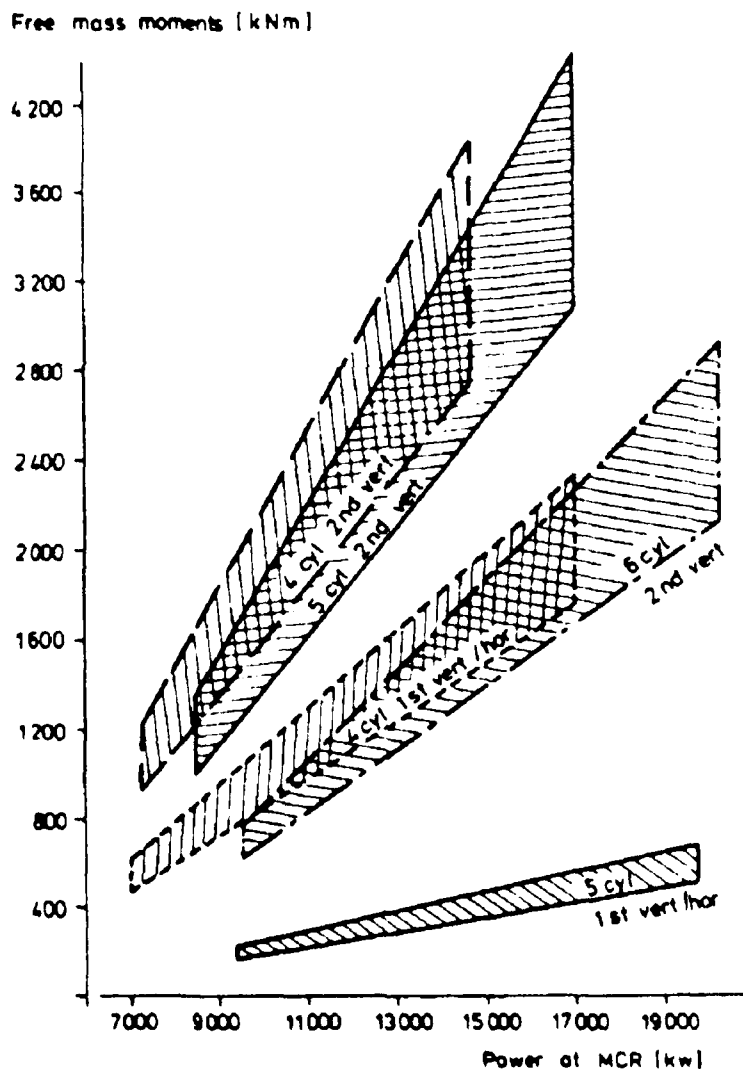

Figure 4-20

External 1st and 2nd Order Moments for 4, 5 and 6 Cylinder Two-Stroke Engines

4.3.2 Forced Hull Response

The principal blade-frequency forces affecting the vertical and horizontal hull responses are the vertical (F_V) and horizontal (F_H) hull forces, respectively. The vertical hull force is a combination of the vertical bearing force and hull pressure force. To avoid resonance at blade frequency, (number of blades x RPM), it is best to choose this combination so that the normal operating frequency is above the sixth vertical mode and not in resonance with a horizontal mode. In that case (above the 5th or 6th mode) the hull response is representative of a forced response rather than a resonant response and the amplitude of vibration is proportional to the driving force.

4.3.2.1 Estimated Hull Forces

As mentioned in Chapter Three, the components of vertical hull force are the alternating hull pressure force and the vertical bearing force, while the horizontal hull force consists of the horizontal bearing force only since there will normally be little effect of the hull pressure force exhibited in the horizontal plane. Propeller bearing forces, F_V and F_H , may be estimated from wake studies performed on similar ship types, or empirically as developed in Chapter Three for alternate stern configurations. These values are given in terms of a percentage of steady thrust developed by the ship. The hull pressure force can be radically increased by cavitation effects and result in total hull forces being increased by a factor of ten or more, if serious cavitation occurs. Under normal circumstances (assuming the rules for avoiding cavitation are followed) it is assumed that an equal and in-phase pressure force, combined with the bearing force, acts on the hull. Also, since the trial requirements stipulate that shipboard vibration measurements be "maximum repetitive amplitude," (MRA), under controlled test and trial conditions, a factor of two greater than the predicted sinusoidal response plus a second factor due to trial signal modulation is introduced. Thus, $F_V = 2 \times 2 \times$ Estimated (sinusoidal) forces, and $F_H = 2 \times$ Estimated (sinusoidal) forces.

4.3.2.2 Hull Response

The response of the hull in a non-resonant condition above the 5th or 6th mode, may be estimated by the impedance method proposed by McGoldrick [4-28]. The mass or hull impedance, Z , is defined as:

$$Z = \frac{F}{\delta}$$

where:

F is the excitation force induced by the propeller

δ is the hull displacement at the stern induced by the forces.

The impedance is found, theoretically, to be a function of the elastic properties, inertia, damping and driving force frequency. Based on studies conducted on a few ships, McGoldrick developed an empirical expression for the hull impedance, as:

$$Z = \alpha \Lambda (CPM)^2$$

where:

α = an empirical constant for a given ship type.

Λ = displacement of the ship in long tons.

CPM = blade frequency in cycles per minute.

For the Mariner class Cargo Ship, $\alpha = 3.4 \times 10^{-6}$ from [4-29]. For the LNG Carrier (125,000 CM), $\alpha = 8.323 \times 10^{-7}$ from [4-30].

Based on full scale studies conducted on a few ships ranging from 7,800 tons to 94,000 tons, hull impedance curves for vertical and horizontal vibration, as shown in Figure 4-21, taken from the T-AO 187 Baseline Review, [4-26], were developed. Using these curves as the basis, the estimated hull response to the derived input forces for the 40,000 ton T-AO was:

Vertically: $\pm 5,200$ lbs. $\Rightarrow \pm 0.52$ mils. (5200 lbs/10000 lbs/mil)
 Horizontally: $\pm 3,600$ lbs. $\Rightarrow \pm 0.60$ mils. (3600 lbs/6000 lbs/mil)

For the T-AO equipped with two shafts, to include the in-phase forces for both shafts, the following factors are recommended:

A	Full power, trial conditions	2
B	MCR, rough seas	5
C	Case B, plus hard maneuvers (2x5)	10 ¹

Applying the factors for the three cases described above to the predicted hull response, the values in Table 4-9 are obtained:

Table 4-9 Amplitude at the Stern, \pm mils.

Case	Vertical	Horizontal
A	1.04	1.2
B	2.60	3.0
C	5.20	6.0

For reference purposes, the amplitudes of Horizontal (Athwartships) vibration for Cases A, B, and C are shown in Figure 4-22. The vertical amplitudes are slightly less. Case A would be representative of design trial conditions.

4.3.3 Resonant Hull Response

As in any dynamic system, the response is determined by the exciting forces and moments and the damping in the system. In the theoretical approach to the problem of hull vibration the input forces and moments are derived from model wake data and applied to FEM or Beam analyses, sometimes with damping inputs. At times, some investigators use an undamped analysis and then estimate an appropriate magnification factor, based on their experience. It is the experience of the author and the theme of this design guide that it is feasible to develop conservative input forcing functions based on stern configuration and propeller characteristics,

-
- 1 The factor of two times Case B is considered appropriate for tankers. A factor of three times Case B would be recommended for a destroyer.

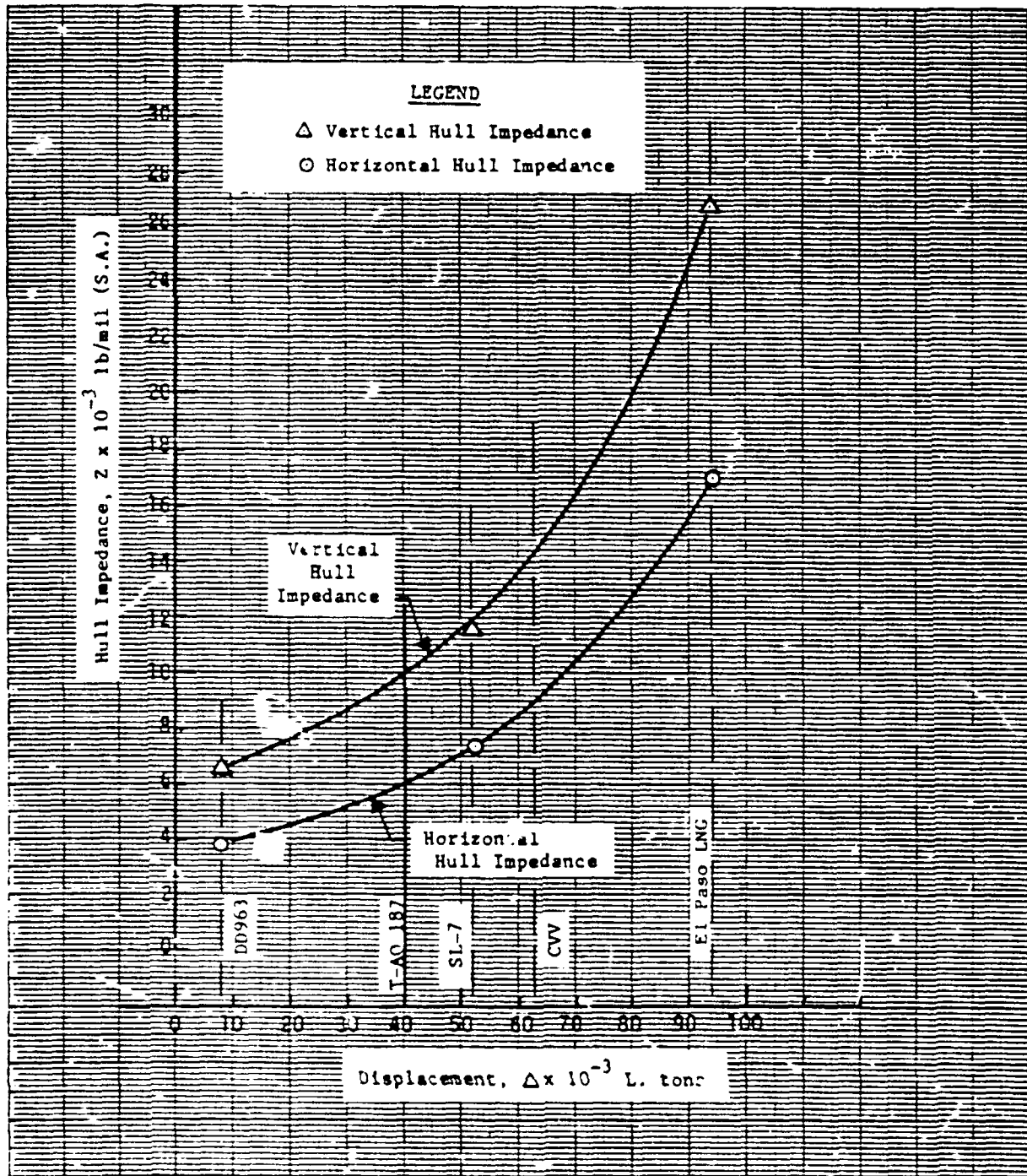

Figure 4-21
 Variations of Hull Impedances versus Ship Displacement

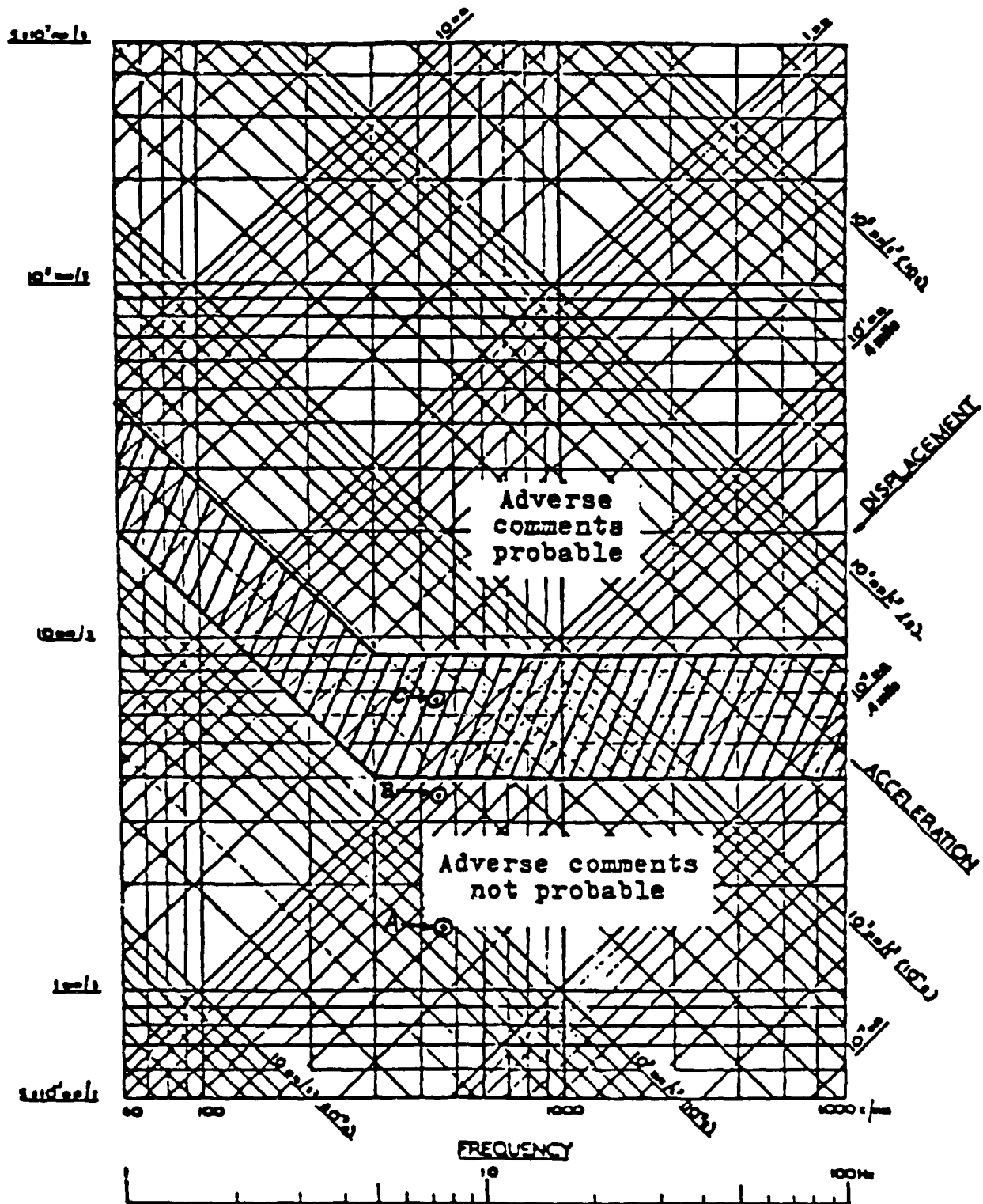

Figure 4-22

ISO Guidelines for Vertical and Horizontal Vibration in Merchant Ships (Peak Values)

Ship Vibration Design Guide

if appropriate attention is given to the avoidance of cavitation. In either case, theoretical or empirical development of propeller forces for the system can be realistically determined. The system damping, however, has been the subject of much controversy and continues to be investigated.

In this section of the guide, the following subsections are treated: Hull Vibratory Forces, Hull Damping, Concept Design (Estimated Hull Response) and Preliminary Design (Calculated Hull Response).

4.3.3.1 Hull Vibratory Forces

Hull vibratory forces may be developed theoretically, deduced from previous studies on similar designs, or estimated from experience factors obtained on alternate propellers and stern configurations. The first case (theoretical) is more appropriately carried out on large budget projects in which the expenditure of much time and money can be justified. However, little work has been done on the verification of such studies via full scale testing. When considering the uncertainties associated with cavitation, damping and the modulation of shipboard vibration signals, plus the reliability of instrumentation selection and usage, coupled with the cost, time and availability of the required ship and propeller data, there would seem to be little justification to support this approach on a typical low-budget ship design program.

The second case, used in the T-AO Baseline Review [4-26] and in the preliminary vibration analysis of the DD 963 [4-18] would be extremely valuable if the data base was extended to a broad range of ship types. These studies were based on the broad use of empirical factors and previous studies on similar ships.

The third case, based largely on the work carried out on the LNG Carriers, indicates the feasibility of developing empirical input functions relating primarily with stern configuration and propeller design. This approach has been employed for many years in estimating the propeller induced alternating torque in main propulsion machinery systems.

In this guide, estimating propeller forces by either the second or third method noted above is recommended for most typical commercial ship programs. In the T-AO and DD 963 studies, propeller forces were based on theoretical analyses on similar ship types and deduced forces were determined, as noted in the second case. A factor of two was added to include the effects of hull pressure forces. It was assumed or verified by test that the required caution was employed, to avoid cavitation. Limited data is currently available to give specific values on alternate hull configurations. However, it is considered feasible to develop a suitable data base from existing ship data.

4.3.3.2 Hull Damping

Damping values used by the author are derived from experimental observations on surface ships, as reported by Foster and Alma [4-31], who conducted anchor drop tests to excite transient vibrations of the hulls at low frequencies. Their findings indicated that damping varied with frequency and a curve for damping values as $C_{\mu\omega} = 8.5 \times 10^{-4}$, which is shown in Fig. 4-23 was proposed.

For convenience of input to the computer, a step function with the following incremental values has been used, as proposed by Honke and Perkins [4-32]:

Table 4-10 Step Function Input Damping Factors

Frequency Range (Hz)	Damping Factor, $C_{\mu\omega}$	Magnification Factor, Q
0.5 to 2.0	.01	100
2.0 to 4.0	.014	71.4
4.0 to 5.5	.024	41.7
5.5 to 7.5	.035	28.6
7.5 to 9.5	.045	22.2
over 9.5	.064	15.6

This step function is also shown on Figure 4-23. The damping factor corresponds to percent of critical damping. The damping factor is the reciprocal of the magnification factor, Q , i.e. $Q = \frac{1}{C_{\mu\omega}}$.

Thus $C_{\mu\omega} = 0.064$ corresponds to a magnification factor of 15.6. This set of damping values was used in the Avondale LNG Hull Vibration Analysis [4-24] with good results. For comparative information on hull damping, Figure 4-24 from [4-33] shows the damping coefficients used by various investigators. Further work is required on this subject, preferably by conducting design analyses and ship trials and deducing underway damping characteristics.

4.3.3.3 Concept Design-Estimated Response

During the concept design phase of the T-AO Baseline Study, the horizontal mode, estimated at 447 CPM, was indeed resonant at 450 CPM (5 blades @ 90 RPM) and with a magnification factor, Q , of 22.2, yields:

F_H (Hor. Brg. Force) = $\pm 1,000$ lbs. and $\pm 2,000$ lbs. for two shafts in phase.

From the impedance curve of Figure 4-21, the hull impedance = $\pm 6,000$ lbs/mil. The non-resonant amplitude = $\frac{2,000}{6,000} = \pm .33$ mils; $Q = 22.2$ @ 7.5 Hz. The resonant amplitude = $22.2 \times .33 = \pm 7.3$ mils and if multiplied by the Trial Factor of 2, the estimated amplitude would be ± 14.6 mils. On the ISO Plot, in Figure 4-22, this amplitude at 7.5 Hz, would be equivalent to a velocity of approximately 18 mm/sec, well above the recommended value of 9 mm/sec.

This result would appear to be excessive. However, it should be noted that the magnification factors are high since they do not include the effects of cargo. Thus, true resonance is not likely to occur, or could easily be avoided and the trial factor of 2, for horizontal hull vibration is probably high. It is also noted that in this case at the fifth mode, the analytical model is in the transition phase from resonant to forced vibration. Of the two options available, the 5 bladed propeller at 90 RPM was the clear choice.

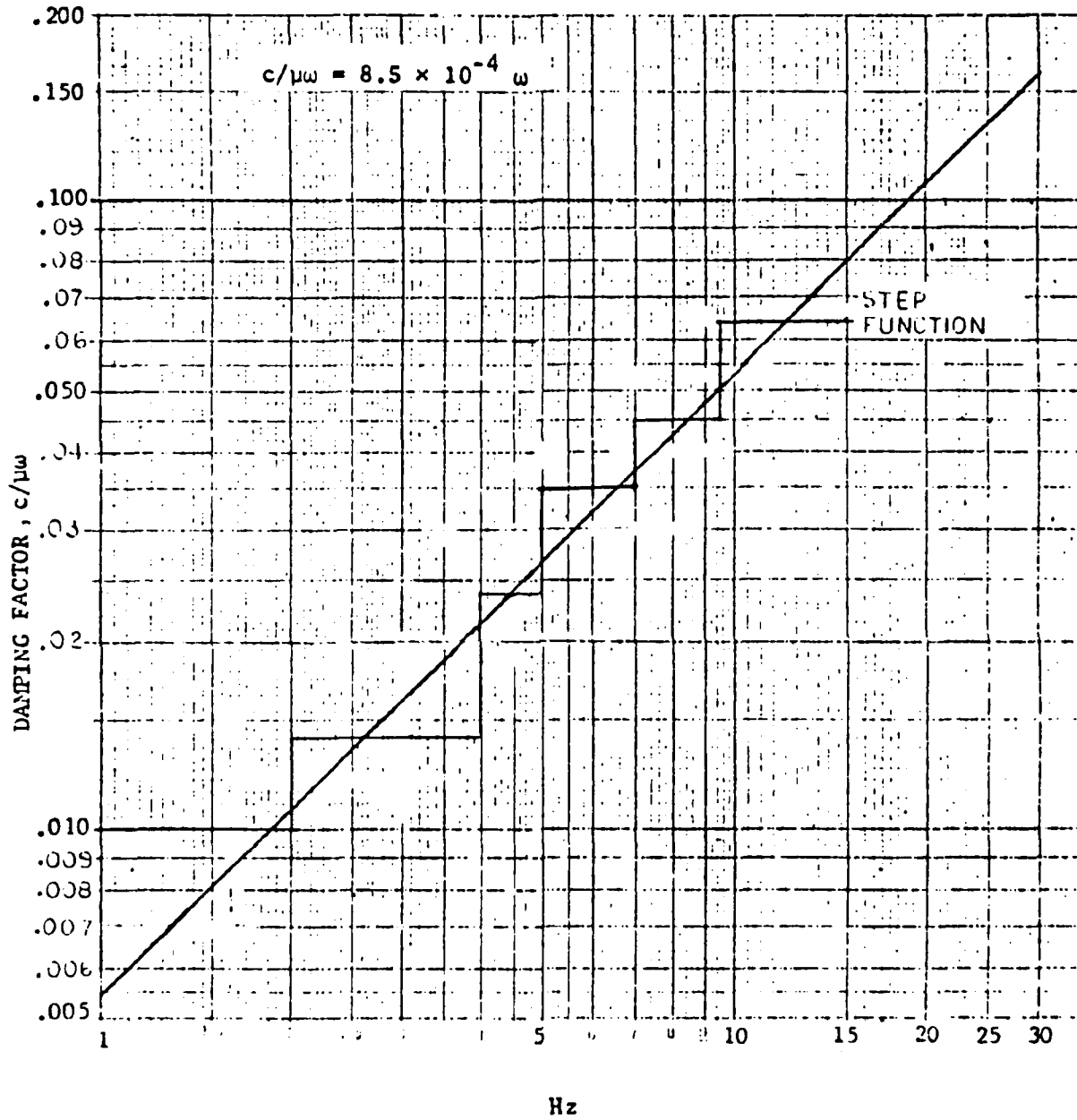

Figure 4-23
Hull Damping versus Frequency

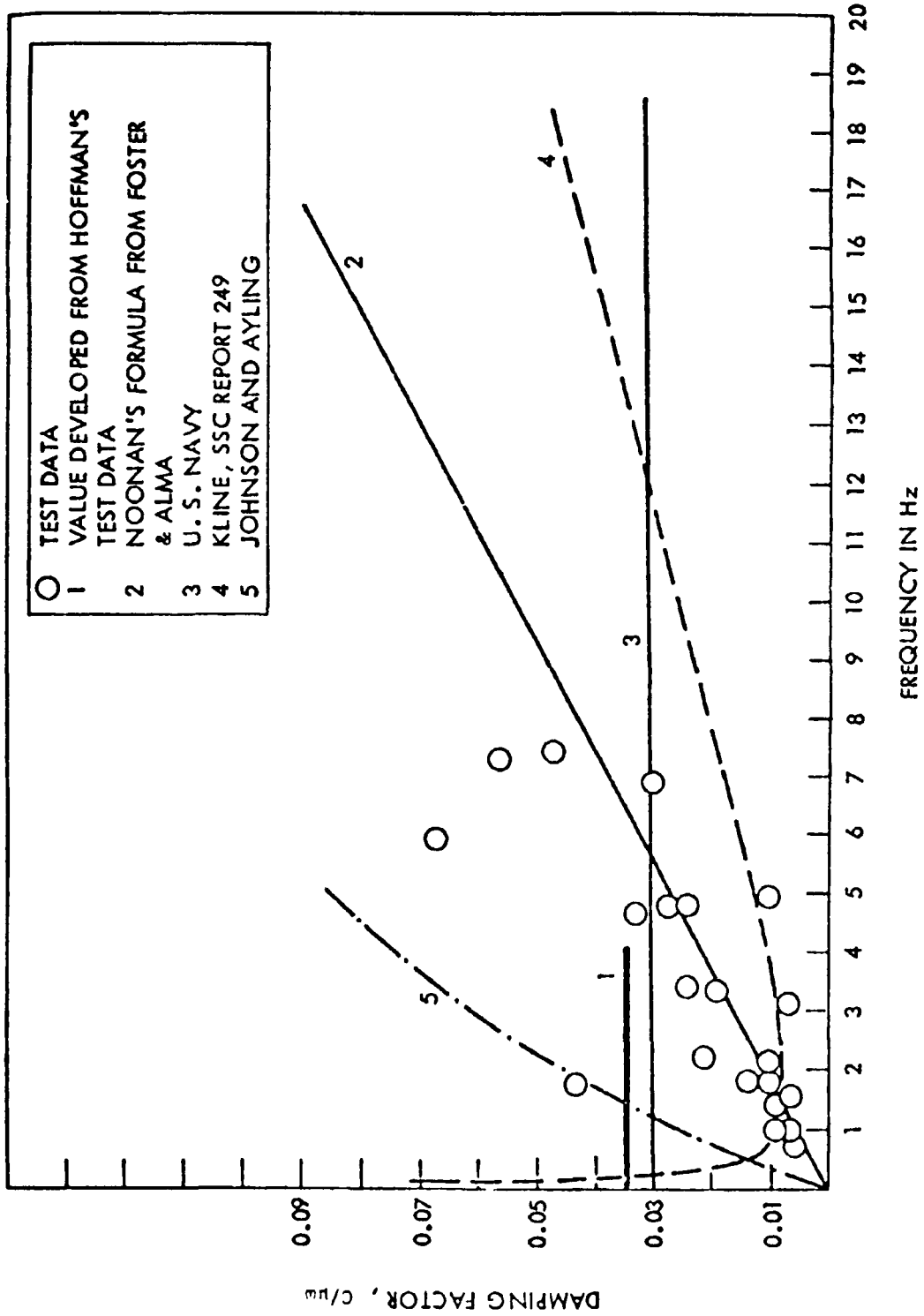

Figure 4-24

Damping Coefficients Used by Various Investigators

Ship Vibration Design Guide

By referring to Section 4.2.3.3 in this chapter, the close similarity between Ship I - Baseline T-AO 187 and Ship II - As-Built T-AO 187 with regard to hull characteristics and estimated fundamental hull frequency is apparent. By relating the actual frequencies obtained by test, for Ship II, as shown in the first column of Tables 4-6 and 4-7, with the estimated values, the fifth horizontal mode, column 4 of Table 4-7 ($\mu = 1.02$), as recommended by Todd, gives a value of 7.34 Hz, or 440 CPM vs 447 CPM obtained in the earlier T-AO Base-line Study. While this would represent less than a two percent difference for the 5th mode, other variations exist, which would indicate the desirability of carrying out the more reliable Beam or FEM analysis in the preliminary design phase.

Of particular importance would be the true ratios between F_V and F_H in the fundamental and higher frequencies. This can be obtained by systematically conducting and documenting ship vibration test results, for various ship types.

4.3.3.4 Preliminary Design-Calculated Hull Response

In Section 4.3.2.2, an empirical method of estimating hull response for non-resonant conditions by the use of the hull impedance approach was presented. In the previous section (4.3.3.3), this approach was extended to the earliest shipboard analysis, carried out during the concept design phase of the program to obtain an estimate of hull response and expected resonant conditions, using the initially planned ship characteristics. Based on that analysis and the interpretation of the results, a more detailed analysis may be required to confirm the first opinion; to better judge possible changes to the system, if required; and to gain a better understanding of the total system response for a direct comparison with specifications or other acceptance criteria.

For the preliminary design phase, where the required ship detailed characteristics have been established, the choice of computer models may include:

- A 20-station beam model
- B FEM of aft portion of the hull and forward beam model
- C Complete FEM

Descriptions of these alternate programs have been given in earlier sections of this chapter. The complexity of the analysis and the associated time and cost increases in the order listed. The least expensive model has been used with good results. A few cases referred to in this chapter, include references [4-11], [4-12], [4-16], and [4-18]. Complete detailed calculation procedures for this model have been published in Marine Technology [4-11].

Procedure B includes a FEM of the aft (approximately 25%) portion of the ship, coupled with the beam-like fore-body model. Proper care must be taken to ensure the complete transmission of motion across the interface. Reference [4-16] provides details of the finite element method and comparison with the conventional method (A). This FEM gives satisfactory results on natural frequencies of ship's hull, as checked by the conventional 20-station beam model and provides the basis for the more detailed evaluation of the aft deckhouse, as required. For most cases, however, method (A) is simpler, less expensive and faster for the determination of hull frequencies through the sixth mode, after which the hull responds to forced vibration. Typical response data is shown in Figure 4-25.

Procedure (C) is most expensive, time consuming and requires the most detailed structural information. Generally run on a NASTRAN computer program [4-17] or equivalent, it can produce detailed mode patterns, as shown in Figs. 4-5 to 4-9. Results of response studies are, however, only as good as the input functions and damping assumptions, which are common to all three procedures. Such detailed analysis is best suited for the evaluation of more limited models associated with the evaluation of major substructures, such as deckhouse, large deck structures, and machinery foundations.

With respect to ship hull vibration, the response of the main hull girder, which provides the input function to the major substructures and local structural components, can be estimated by the impedance method. Computer model (A) is recommended as being efficient for most preliminary design analysis. Model (B) can be used more effectively when detailed response of hull major substructures is required. For the detail design analysis, model (C) is considered more appropriate.

For purposes of comparison of the various computing methods discussed, results of analyses, adjusted to the same input functions, are shown in Figure 4-26, taken from [4-30]. At 111 RPM, the vertical stern response at blade-rate and predicted by the alternate methods show good agreement.

4.4 General Comments and Recommendations

The ability to predict and design against objectionable vibration varies widely in the technological world. First, one must identify what is objectionable, which may vary from fatigue stress limits to human reaction; then establish suitable criteria as a basis for judgment of the phenomena; obtain or develop adequate means of measuring, of defining the testing conditions and of evaluating the data obtained; and finally develop an analytical procedure by which, with reasonable confidence, the designer can meet the criteria or specifications. In some relatively simple systems, such as engine excited torsional vibration in a diesel-generator set where the engine harmonics precipitate crankshaft resonances, it has been a relatively straightforward procedure to technically resolve the problem. In ship hull vibration, however, the problem is much more complex, largely due to the random nature of the sea environment, which strongly influences the primary exciting forces and the dynamic response of the hull girder, which effects the total structural and mechanical system.

A good understanding of hydrodynamic theory involved has been achieved. Laboratory techniques for the measurement of forces, extensive finite element programs for the evaluation of large complex structures and international standards on methods of measurement and evaluation of ship vibration have also evolved. However, the many variables in the total system still require many judgment calls and an extensive "design cycle" program to reliably evaluate a design. Such an approach is only suited to large, expensive programs and does not fit well with the normal, low-budget program described in the "Stages of Ship Design" (4.1.3). For this reason, with regard to shipboard vibration, shipbuilding is still considered an art.

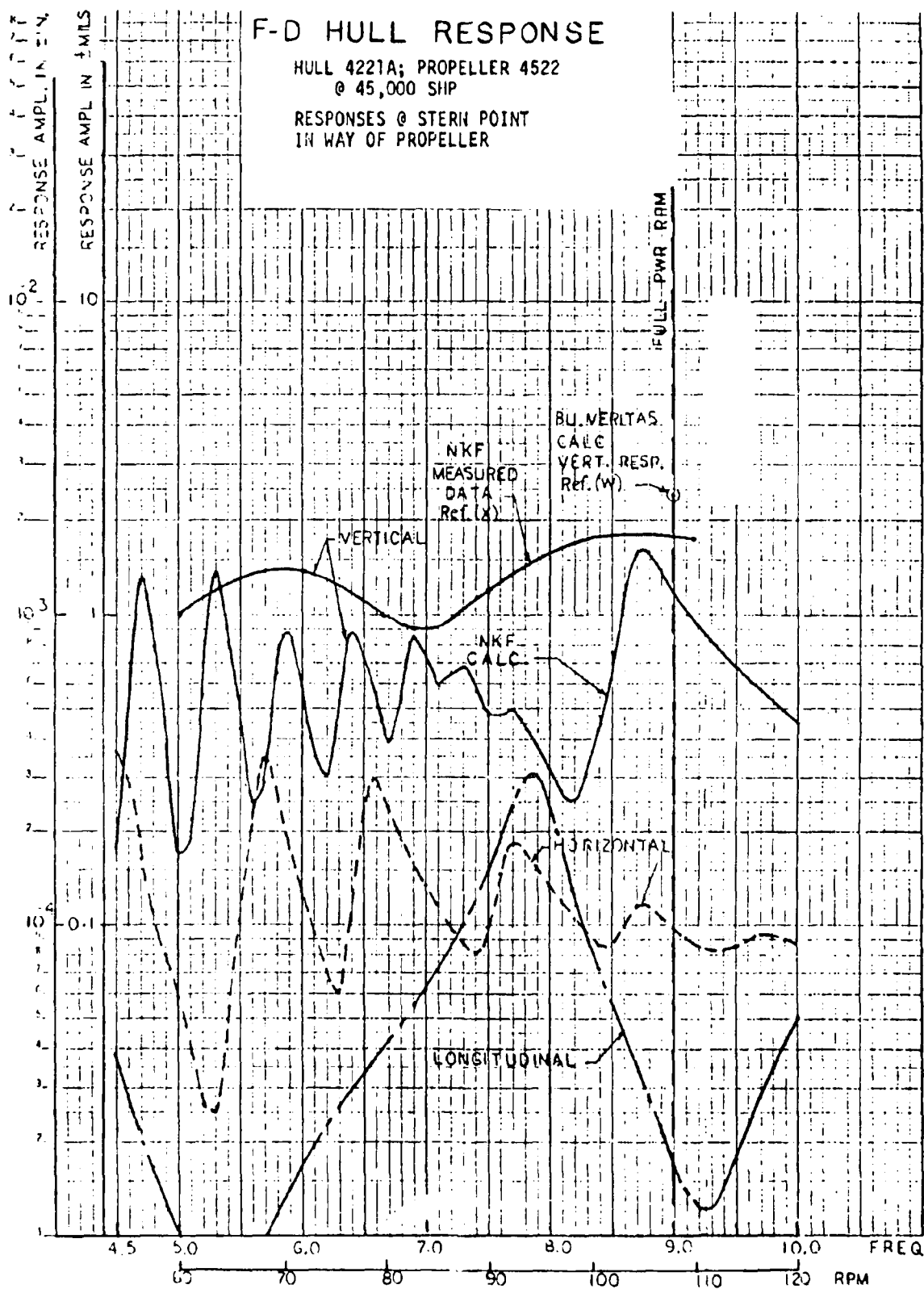

Figure 4-25
France-Dunkerque Hull Response

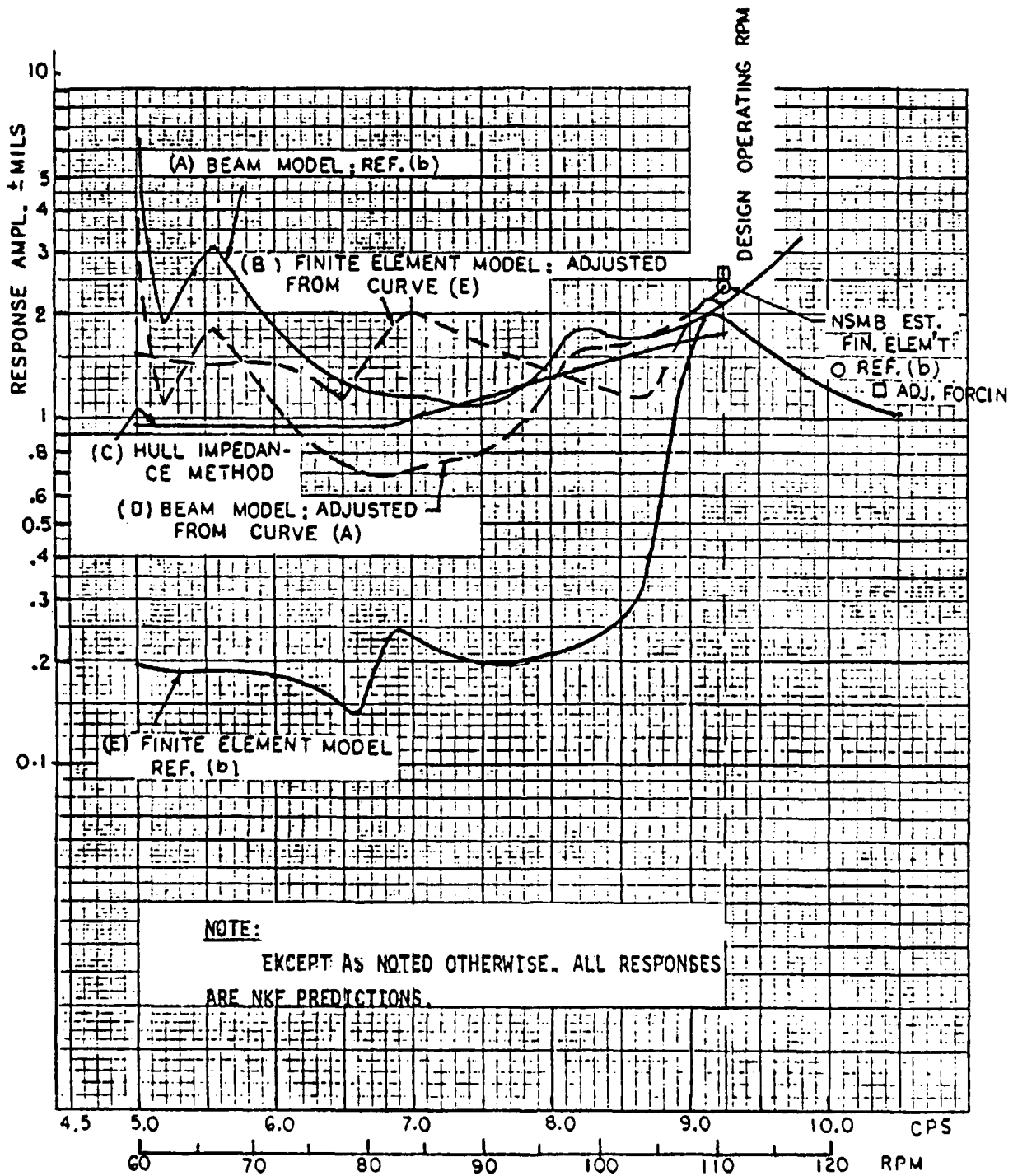

Figure 4-26
 Predicted Avondale Hull Response

Ship Vibration Design Guide

This guide is developed in a specific manner in which each chapter, although interacting with the others, represents basic technical areas, which can be developed and updated individually. It is also based on the concept of translating the product of research into practical application by the use of empirical means, in order to include shipboard vibration as a line-item in the development of the average shipbuilding program. With these thoughts in mind, the following comments and recommendations are submitted as pertinent to Chapter Four.

4.4.1 General Comments

Hull vibration should be considered in the early decisions to be made during the concept and preliminary design stages of any shipbuilding program. It should be noted that vibration specifications, based on ISO Standards, are currently being employed.

Empirical estimates of hull frequencies can be made during the concept stage to influence the choice of machinery type, location of engines, shaft RPM, number of shafts, number and type of propeller blades, etc.

Empirical estimates of propeller forces, damping factors and hull response for evaluation against specifications or other applicable criteria can be developed in the preliminary design stage.

The 20-station Beam analysis is considered suitable for preliminary design purposes, particularly when the proposed design deviates from classification society rules or represents a unique ship type.

The more expensive and time consuming FEM analysis method is most suitable for the detailed evaluation of ship structures, particularly in the aft portion of the ship, during the contract and detail design stages.

A more extensive supplement, dealing with major substructures, including large, slow-speed diesel engine installations and local vibration, should be considered.

4.4.2 Recommendations

The early development of a practical "Ship Vibration Design Guide" depends heavily on the availability of design analyses and shipboard vibration test data to expand the limited data base. Since such data is extremely difficult to obtain from private industry and in most cases, questionable in reliability, it is recommended that a program be developed for this purpose by the American Bureau of Shipping, which can be effectively carried out at low cost and in a properly organized manner. This would also enhance the ABS ship design and testing capability.

The guide as written is not intended to be an end product but rather a pilot effort to establish the concept of a practical approach to the control of shipboard vibration. As such, its expansion and/or updating should be considered the norm. In this light it is recognized that specific work is required in the development of more detailed guidance on the analysis and testing of large, slow-speed diesel engine installations.

REFERENCES

- 4-1 Todd, F. M., Ship Hull Vibration, Edward Arnold (Publishers) Ltd., London, 1961.
- 4-2 Lewis, F. M., "Hull Vibration of Ships," Chapter X, S.N.A.M.E. Principles of Naval Architecture, 1967.
- 4-3 Boylston, J. W. and Leback, W. G., "Toward Responsible Shipbuilding," S.N.A.M.E. Transactions, 1975.
- 4-4 Taggart, R., "Ship Design and Construction," S.N.A.M.E., 1980.
- 4-5 Noonan, E.F., "An Assessment of Current Shipboard Vibration Technology," Ship Structures Symposium 1975, S.N.A.M.E. Publication SY-5.
- 4-6 Schlick, O., "Further Investigations of Vibration of Steamers," R.I.N.A. 1894.
- 4-7 Dinsenbacker, A. L. and Perkins, R. L., "A Simplified Method for Computing Vertical Hull Natural Frequencies and Mode Shapes in Preliminary Design Stage," D.T.R.C. Report 3881, January, 1973.
- 4-8 Leibowitz, R. and Kennard, E., "Theory of Freely Vibrating Nonuniform Beams, Including Methods of Solution and Application to Ships," DTMB Report 1317, May, 1961.
- 4-9 Bruck, H. A., "Procedure for Calculating Vibration Parameters of Surface Ships," NSRDC Report 2875, December, 1968.
- 4-10 Cuthill, E. H. and Henderson, F. M., "Description and Usage of General Bending Response Code 1, (GBRC1)," DTMB Report 1925, July, 1965.
- 4-11 Noonan, E. F., "Design Considerations for Shipboard Vibration," S.N.A.M.E., Marine Technology, January, 1971.
- 4-12 "124,000 CM LNG Carrier, F-D Hull Vibration Analysis Using 20-Station Beam Model," NKF Technical Note 7321-9, August, 1975.
- 4-13 MRI/Stardyne 3, "Static and Dynamic Structural Analysis Systems, User Information," developed by Mechanics Research, Inc., available through Control Data Corp.
- 4-14 MRI/Stardyne, Static and Dynamic structural System, Theoretical Manual, available through Control Data Corp.
- 4-15 Guyan, R. J., "Reduction of Stiffness and Mass Matrices," AIAA Journal, Vol . 3, No. 2, February, 1965.

Ship Vibration Design Guide

- 4-16 "Avondale Hull Vibration Analysis by Finite-Element Method Including Comparison with Conventional Beam Method on 125,000 CM LNG Carrier," NKF Technical Note 7321-8, August, 1975.
- 4-17 MacNeal, R. H., "The NASTRAN Theoretical Manual, Level 15," a NASA Publication, April 1972.
- 4-18 Noonan, E. F., "Preliminary Hull and Machinery Vibration Analysis for DD 963 Class Destroyer Design," NKF Report No. 7105-1, to Litton Systems, Inc., February, 1971.
- 4-19 Ali, H. B., "Calculated Natural Frequencies and Normal Modes of Vibration of *USS Brumby*, (DE-1044)," NSRDC Report 2619, March, 1968.
- 4-20 Horn, F., "Horizontal and Torsionschwingurigen and Frachtschiffen," Werft Reederie Hafen, 1925.
- 4-21 Noonan, E. F. "Vibration Considerations for 120,000 CM LNG Ships," NKF: Preliminary Report No. 7107, 25 January, 1971.
- 4-22 Noonan, E. F., "Vibration Considerations on Project and Conventional Hulls for 120,000 CM LNG Ships," Final Report No. 7107, 28 May, 1971.
- 4-23 NKF TN 7321-9 "125,000 LNG Carrier, F-D Hull Vibration Analysis Using 20-Station Beam Model," 19 August, 1975.
- 4-24 NKF TN 7321-8 "Avondale Hull Vibration Analysis by Finite Element Method Including Comparison with Conventional Beam Method on 125,000 CM LNG Carrier," 12 August, 1975.
- 4-25 Brown, T.W.F. , "Vibration Problems from the Marine Engineering Point of View," N.E.C.I., 1939.
- 4-26 T-AO 187 Baseline Review, "An Evaluation of the Proposed Propeller-Hull Configuration," NKF Report 8213, May 1982.
- 4-27 Payer, H.G. and Asmussen, I., "Vibration Response on Propulsion-Efficient Container Vessels," S.N.A.M.E. Transactions, 1985.
- 4-28 McGoldrick, R.T., "Ship Vibration," DTMB Report No. 1451, December 1960.
- 4-29 McGoldrick, R.T., and Russo, V.L., "Hull Vibration Investigation on *SS Gopher Mariner*" DTMB Report 1060, July, 1956.
- 4-30 NKF TN 7321-15 "Avondale Hull No. 4628, Prediction of Underway Hull Response at Stern by the Hull Impedance Method Including Comparison with Results by the Traditional Beam Method and the Finite Element Method," 15 June, 1976.

- 4-31 Foster, W.P. and Alma, H.F., "Damping Values of Naval Ships Obtained from Impulse Loadings," Shock and Vibration Bulletin No. 40, December, 1970.
- 4-32 Honke, P. and Perkins, R., "Vibration Characteristics of Hull and Propulsion System for Patrol Frigate," NSRDC Report No. SAD-C30E-1962 (1973).
- 4-33 Chang, P.Y. and Carroll, T.P., Ship Structure Committee Report SSC-306, "Experimental Program for Determination of Hull Structural Damping Coefficients," 1981.

APPENDIX 4-A

Comments on "Ship Vibration Design Guide," Preliminary Draft Report

(Prepared by Jeng Wen Chiou, Senior Engineer, ABS)

I agree with the author that the values of the coefficients in the Todd formula for tankers should be changed to reflect current vessel experience. A study of validity of the formula was made with $C_1 = 45,000$ and $C_2 = 25$ for four tankers, which already have the lowest mode natural frequency results either calculated by using 3-D finite element models representing the entire ship or measured on board. Table 4-A-1 shows the results obtained by using the Todd formula as compared to the FEM calculations or the measured data. The comparison reveals that by using the Todd formula, the estimation of the lowest frequency of the three tankers for which LBP is less than 770 feet is adequate. The one exception is the result estimated by using the formula for the supertanker with LBP equal to 1150 feet, which is 53% away from the measured data.

As to the formula for estimating the higher mode frequencies, it appears that the formula $N_{2V}(n - 1)\mu_V$ used in this guide would produce more accurate results than the formula $N_{2V}(n - 1)^{\mu_V}$ employed by DnV. For illustrative vessels, Table 4-A-2 presents frequency ratio derived from measured data, 3-D FEM calculations and from above mentioned formula. From the table it is found that the ratio obtained by using the formula suggested in the draft guide follows the trend of the ratio derived from the measured data. Nonetheless, it is recommended that setting $\mu_V = 1.05$ for 3-node mode to 5-node mode and $\mu_V = 1.02$ for 6-node mode and higher modes be used in the formula.

Table 4-A-1 Estimation of 2-Node Mode Natural Frequency (Hz) for Tankers

Ship Number	Loading Condition	Characteristics					2-Node Vertical Mode Frequency		
		L	B	D	T	Δ	Todd Formula	3-D FEM Calculations	Test
1	Ballast	548	91.8	49	20	21720	1.2	1.21	
	Laden	548	91.8	49	34	38900	1.09	0.97	
2	Ballast	554	106	57	20	24560	1.34	1.34	
	Laden	554	106	57	37	49000	1.19	1.13	
3	Ballast	770	130	75	25	56000	1.05	0.98	
	Laden	770	130	75	52	121200	0.93	0.83	
4	Ballast	1148	197	93	34	172000	0.75		0.49

Table 4-A-2 Estimation of Natural Frequency Ratio for Higher Mode of Tankers

Mode Number	Figure 17 of Guide *	B.S.R.A 16 Ships**	2 FEM & 1 Test***	$N(n-1) \mu_V$		$N(n-1) \mu_V$	
				$\mu_V = 1.02$	$\mu_V = 1.05$	$\mu_V = 1.02$	$\mu_V = 1.05$
2V	1	1	1	1	1	1	1
3V	2.15	2.15	2.05	2.04	2.1	2.03	2.07
4V	3.20	3.25	3.15	3.06	3.15	3.07	3.17
5V	4.23	4.27	4.10	4.08	4.2	4.11	4.28
6V	5.19	5.07	5.03	5.10	5.25	5.16	5.42
7V	6.19	5.85	5.85	6.12	6.3	6.22	6.56
8V	7.15			7.14	7.35	7.28	7.72

* SSC Project SR-1312

** 16 ship measurement results selected by B.S.R.A.

*** 3-D FEM calculations performed for three tankers by ABS and measurements performed on one tanker by Bureau Veritas

PROPULSION SYSTEM VIBRATION

The main propulsion system includes all mechanical and structural elements from the prime mover up to and including the propeller. Through the structural attachment of the thrust bearing foundation and the bearing supports, vibratory forces and moments may readily transfer from the ship structure to total machinery system, or from the machinery system to the ship structure. Engine and thrust bearing foundations typically provide the direct transfer of vibratory energy between the hull and main propulsion machinery systems. Propeller generated forces can adversely effect the dynamic response characteristics of the propulsion system and of the hull, through the engine and thrust bearing foundations, while machinery generated dynamic forces can precipitate serious damage to the machinery system and produce excessive hull vibration. In Chapter Four, the effect of propeller-generated vibratory forces on hull vibration were discussed. In this chapter, the dynamic forces and moments generated by the propulsion system, including the propeller, and their effect on the vibratory characteristics of the total propulsion system, are treated.

Of major concern is the dynamic stresses within the system and its components and the control of dynamic forces generated by the propulsion system, which contributes to the vibratory characteristics of the total ship. Although the vibration of both the ship's hull and main machinery are interrelated, it is convenient, both in preliminary design studies and in the control of shipboard vibration, to conduct independent studies on the propulsion system. It is necessary however, to include actual or empirical factors related to the ship's structure that form an important part of the effective mass-elastics system under study, such as the stiffness of the thrust bearing foundation, when evaluating the response of longitudinal vibration of the propulsion system.

The main areas of concern, and which can give rise to troublesome vibration or dynamic stresses, include

- Dynamic Unbalance and Misalignment
- Dynamic Shaft Stresses
- Longitudinal Vibration
- Torsional Vibration
- Lateral Vibration

Ship Vibration Design Guide

The following sections will cover these topics and include both the excitation and response of the propulsion system and its effect on hull vibration.

5.1 Dynamic Unbalance and Misalignment

Dynamic and/or hydrodynamic unbalance of the propeller, dynamic unbalance of shafting, bull gears and other large components of the propulsion system operating at propeller-shaft speed may contribute to objectionable hull vibration, particularly if the exciting frequency falls in resonance with a natural frequency of the hull. Such difficulties may also arise from the primary (1st order) or secondary (2nd order) unbalanced forces in large, slow-speed diesel engines or from serious shaft misalignment (1st order).

It was noted in Chapter Four, that the fundamental vertical natural frequency of a ship's hull may be in the range of one Hz, or 60 cycles per minute. Unbalance in a major component of the propulsion system, such as the propeller, which is located close to the stern, an antinode of hull-girder response, can have a serious effect on the vibration of the ship, if significant dynamic or hydrodynamic unbalance is present. Thus, it is important, if we are to minimize the exciting forces and avoid resonances, that we dynamically balance the propeller, minimize propeller-blade pitch error and avoid important operating shaft speeds at, or near important hull frequencies.

While the actual balancing of machinery components and the check of propeller pitch error are carried out during the construction phase of the shipbuilding program, it is necessary to determine the compatibility of major components with the hull response. The number of shafts, number of propeller blades, shaft RPM, identification of acceptable engines and proposed shafting arrangements and propulsion system vibration characteristics must be evaluated during the preliminary design phase. It is necessary, therefore, to determine the dynamic forces generated by the propellers, shafting, gears, and in the case of low-speed diesel drives, the primary and secondary unbalanced forces and moments inherent in all engines under consideration.

5.1.1 Unbalanced Propeller Forces

The dynamic unbalance criteria given in Section 2.3.1.1 of Chapter Two, taken from MIL-STD-167 [5-1], is applied to specific cases:

<i>W</i> LNG Propeller weight	122,000 lbs	
<i>D</i> LNG Propeller diameter	24.5 ft	(Radius = 12.25 ft)
LNG Propeller RPM	105	

Since the length of the rotor mass is less than 0.5 *D*, a single plane correction is used. The maximum residual unbalance is:

$U = 0.177 W$ for speeds below 150 RPM, = 21,594 oz-ins = 112.5 ft-lbs. This is equivalent to an average correction of 12.85 lbs @ 0.7 radius, or 9.18 lbs at the

propeller tip. The allowable unbalance would generate a centrifugal force at 105 RPM equal to:

$$F = \frac{W}{g} \times \frac{v^2}{R}$$

where:

$$\begin{aligned} v &= \text{linear velocity of unbalanced weight} \\ &= \frac{2\pi RN}{60} \end{aligned}$$

therefore:

$$F = \frac{9.18}{32.2} \times \frac{(3.14 \times 105)^2}{900} \times 12.25 = 421.8 \text{ lbs}$$

and:

$$\frac{421.8}{122,000} = 0.0035, \text{ or } 0.35\% \text{ of the propeller weight}$$

Applying the same criteria to a twin-screw destroyer propeller, with a weight of 55,000 lbs, 17 ft diameter and operating at 170 RPM, the allowable unbalance would be:

$$U = \frac{4000W}{N^2} = 7612 \text{ oz-ins or } 39.65 \text{ ft-lbs which is } 4.66 \text{ lbs @ } R = 8.5 \text{ ft}$$

The centrifugal force generated would be:

$$F = \frac{4.66}{32.2} \times \frac{(3.14 \times 170)^2}{900} \times 8.5 = 389.33 \text{ lbs}$$

It should be noted, that with two shafts, the allowable vibratory force would be 2 x 389.33 or approximately 779 lbs when the unbalanced forces acted in phase. The allowable force generated by each propeller would be $\frac{389}{55,000} = .7\%$ of the propeller weight.

For a single plane dynamic balance of a disc of similar weight, operating at 1500 RPM, the allowable vibratory force would be:

$$U = \frac{4W}{N} = \frac{4 \times 55,000}{1500} = 146.67 \text{ oz-ins or } 0.764 \text{ ft-lbs (} 0.09 \text{ lbs @ } R = 8.5 \text{ ft)}$$

The dynamic force generated would be:

$$F = \frac{0.09}{32.2} \times \frac{(3.14 \times 1500)^2}{900} \times 8.5 = 585 \text{ lbs or } 1.06\% \text{ of the propeller weight}$$

As an approximate value, to be used in estimating vibratory forces generated by a rotating element, such as a ship's propeller, when balanced to this criteria, one percent of the weight is

Ship Vibration Design Guide

recommended for each propeller. This would also provide some margin for shaft contribution. Similar estimates should be made for bull gears.

In support of this proposed unbalance tolerance, Marine Engineering, Reference [5-2] states, on page 387, "Ship's specifications usually require that propellers be balanced (with static or dynamic equipment) such that the static unbalanced force at rated RPM is no greater than one percent of the propeller weight." These forces should be used in estimating hull response in the preliminary design phase.

Figure 1-9 of Chapter One indicates most ships have a fundamental vertical hull frequency below 2 Hz and most large ships, over 50,000 tons have the fundamental frequency below 1 Hz. If we assume the fundamental athwartship frequency is approximately $1\frac{1}{2}$ times the vertical frequency, we may also deduce the damping factor to be below .01, as shown on Figure 4-23 of Chapter Four and that the magnification factor, at these fundamental resonances would be 100:1, or the equivalent static load would be 100 times the estimated centrifugal force developed by the unbalance present in the propeller. While the detailed calculation of the hull response can be deferred to the detail design phase, it would be prudent in the preliminary design phase, to avoid operating speeds at, or close to hull resonances. This would be particularly true in a design employing large, slow-speed diesels.

For hydrodynamic unbalance, although not readily subject to quantitative evaluation, it is obvious that great care should be taken in the manufacturing process to insure pitch irregularities are kept to a minimum. Specific tolerances are generally invoked, such as given in Marine Engineering [5-2], page 388, but no allowances of the unbalanced forces generated are applicable in the preliminary design phase. As noted above, the application of one percent of the propeller weight, as an estimate for the dynamic unbalance of the propeller, would provide a margin for the possible augmentation introduced by an in phase hydrodynamic unbalance.

5.1.2 Misalignment

As in the case of hydrodynamic unbalance, misalignment could be a potential problem area but is generally referred to as a deficiency in workmanship and no allowances are made for it in the preliminary design phase. Care should be taken, in establishing the location of line shaft bearings to avoid lateral shaft vibration, to determine the setting of stern bearings to minimize wear and particularly to insure proper alignment in large reduction gears. For bearing location and spacing refer to Marine Engineering, [5-2] and for main reduction gear alignment, see "Guide to Propulsion Reduction Gear Alignment and Installation," [5-3]. Procedures for checking lateral shaft vibration, which should be done in the preliminary design phase, is treated in Section 5.5.

5.1.3 Diesel Engine Unbalance

Large, low-speed diesels are currently used more frequently for utilizing slower speed and more efficient propellers. The two-stroke diesel, which is most commonly used, may cause significant hull structural vibration when the frequency and magnitude of free moments coincides with one of the lower hull modes, may cause serious local structural vibration resulting from internal forces and moments or large engine vibrations caused by lateral or

guide-force moments. The engine unbalanced forces and moments are treated here. Engine alternating torques and harmonics and alternating torques produced by the propeller, are treated in Section 5-4, which deals with torsional vibration in propulsion systems.

Hull, structure and engine vibration may result from one or more of the following excitation sources:

- External or free mass forces and moments.
- Internal mass forces and moments.
- Lateral or guide-force moments.

5.1.3.1 External Forces and Moments

The external or free mass forces and moments represents engine unbalance. On the modern two-stroke diesel, the inertia forces are generally neutralized in engines of four or more cylinders, but the external moments may be significant. Aware of the possibility of serious vibration excitation, engine manufacturers can furnish detailed information on the unbalanced moments generated by their engines due to inertia forces. Table 5-1 indicates the presence (x) of free or external moments on modern two-stroke diesel engines:

Table 5-1 Unbalanced Moments in Two-Stroke Engines

Number of Cylinders	1st Order Vertical Moment	1st Order Horizontal Moment	2nd Order Vertical Moment
4	X	X	X
5	X	X	X
6	0	0	X
7	X	X	X
8	X	X	0

Figure 5-1 shows the magnitude range of first and second order moments for four-, five-, and six-cylinder, two-stroke engines from [5-4]. More specific data on the unbalanced forces and moments generated by M.A.N. and Sulzer two-cycle engines are included as Appendix 5-B for information purposes. This data was furnished by the American Bureau of Shipping.

In the preliminary design phase it is important to consider the available engine options, obtain the manufacturers calculated external forces and moments and make preliminary estimates of the effect on hull response based on the planned location. Figure 5-2 shows the external moments (couples) of the engine. Figure 5-3 shows the standard balancing normally provided and the modifications which can reduce the first vertical and horizontal moments. It is important to note that the reduction of one will result in an increase in the other. In some cases, additional balancing can be incorporated for the first horizontal moment, as shown in Figure 5-4.

Since the external moments of the engine are the major contributor to general hull vibration by the combination of large vertical or horizontal moments with a hull resonance, the preliminary

Ship Vibration Design Guide

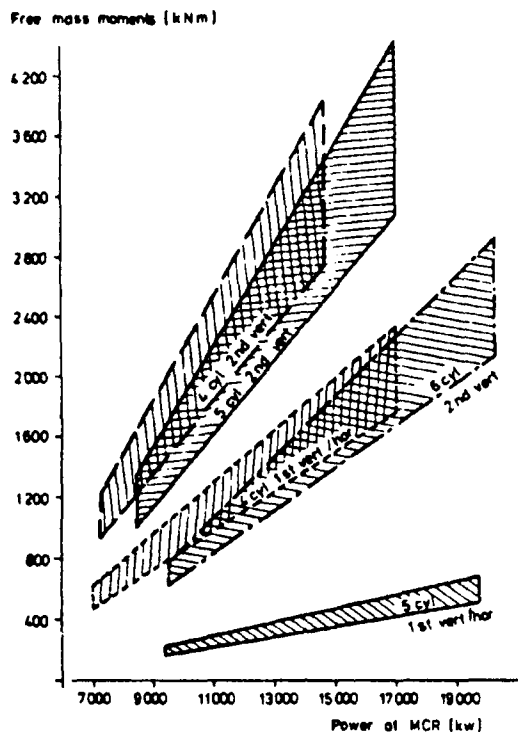

Figure 5-1

External First and Second Order Moments for Four-, Five-, and Six-Cylinder, Two-Stroke Engines

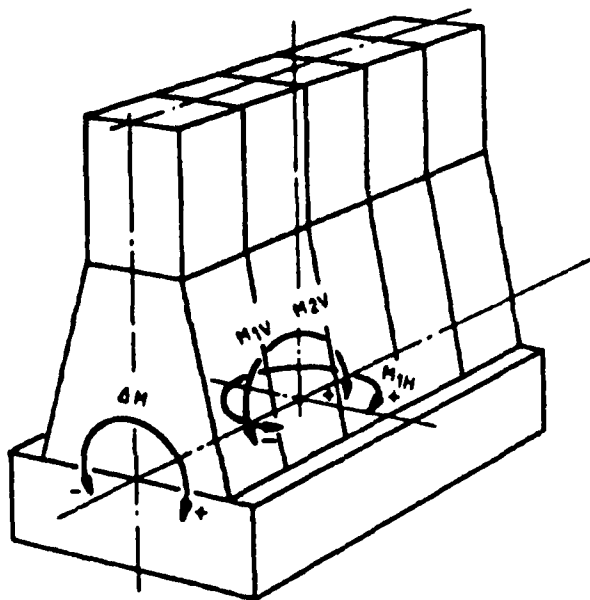

Figure 5-2

External Moments (or Couples) of Engines [5-5]

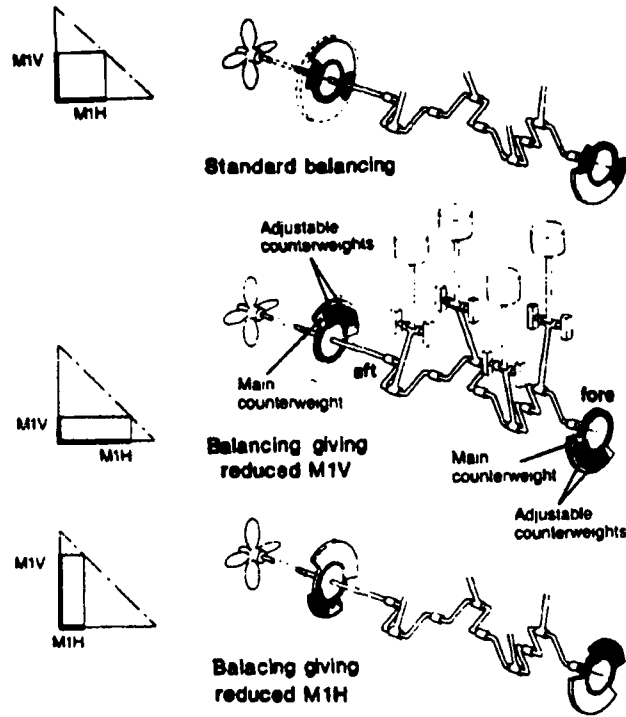

Figure 5-3
Balancing of First Order Moments [5-5]

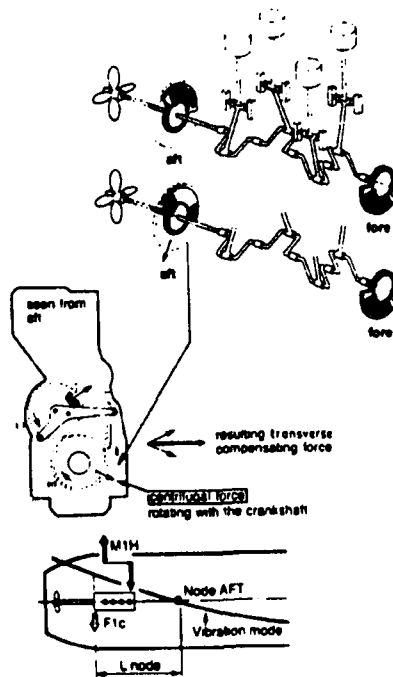

Figure 5-4
Additional Balancing of First Horizontal Moments [5-5]

Ship Vibration Design Guide

design analysis should evaluate the preferred engine for compatibility with the planned location, strength of external forces and moments, and location of hull frequencies and mode shapes. In this regard, it should be noted that the hull response due to external forces is a maximum when the engine is located at an anti-node, while the external moment produces the maximum hull response when the engine is located at a hull nodal point, as shown in Figure 5-5. Thus, if the unbalanced external forces are eliminated, attention can be focused on unbalanced moments.

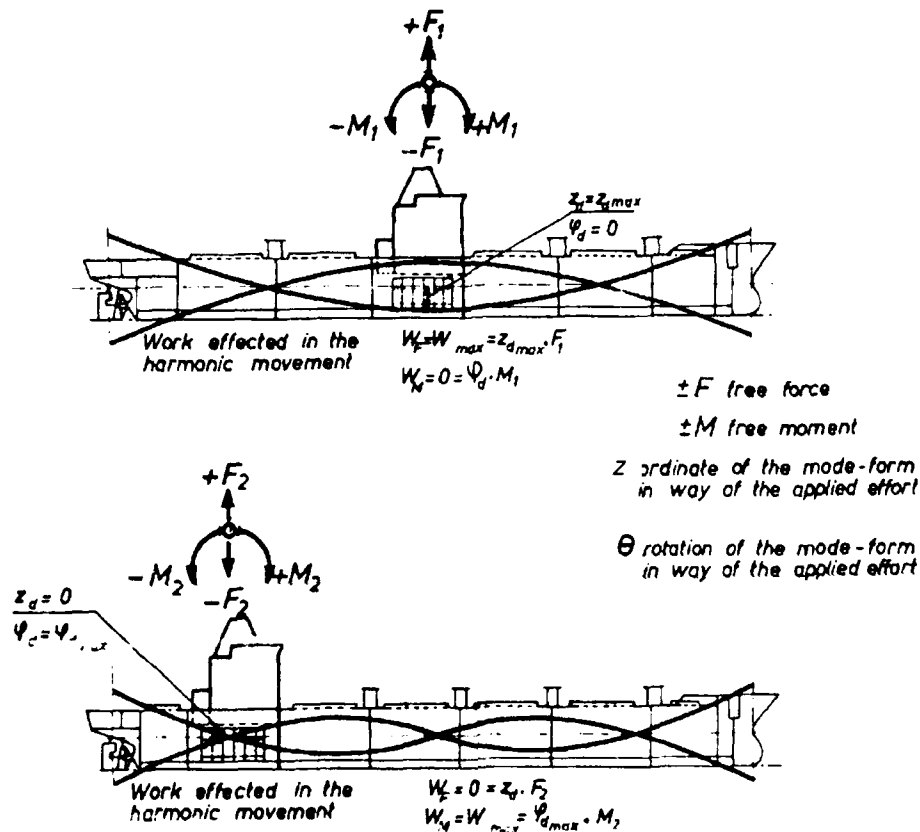

Figure 5-5

Action of External (Free) Forces and Moments on the Hull Girder [5-5]

If necessary, it is also possible to minimize the 2nd order, vertical moment, by including balance weights operating at twice the engine RPM, or by the use of a mechanical exciter at an anti-node in the aft part of the ship, as shown on Figure 5-6, taken from Reference [5-6]. In this situation the frequency of the exciter would operate at two times the RPM. This approach has been used effectively to resolve problems of 1st and 2nd orders of engine unbalanced moments in more than seventy applications. The obvious expense of design, installation and maintenance of such equipment would strongly indicate the importance of the potential problem associated with the treatment of the external engine moments and the necessity of conducting the preliminary design analysis, to avoid potential problems. For a more in-depth study of the subject, see Reference [5-4].

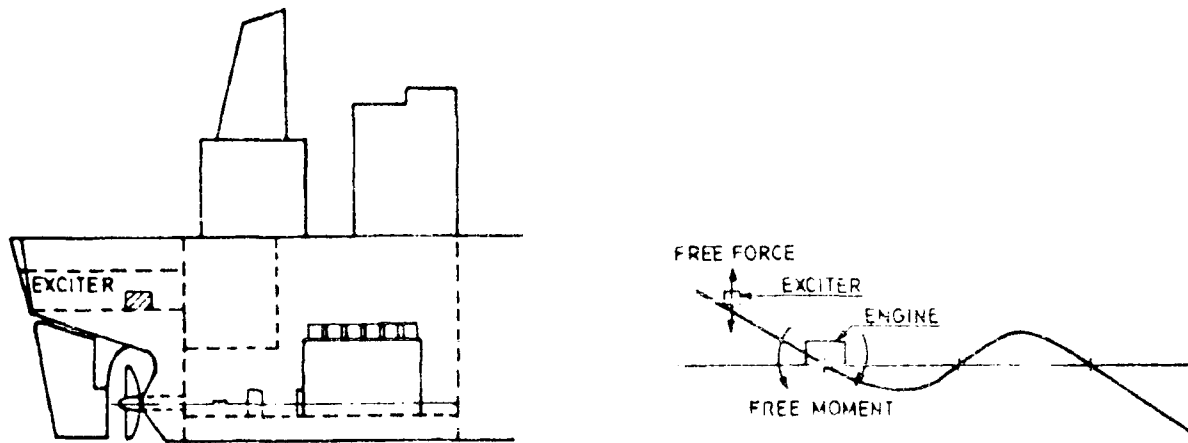

Figure 5-6

Mechanical Exciter Fitted to Compensate for Slow-Speed Diesel Engine Excitation of the Hull Girder

During the preliminary design phase, care should be taken in the following areas, relative to the external (free) forces and moments:

- Engine selection (minimum unbalance and/or ability to correct).
- Avoidance of hull-girder resonances.
- Involve the engine builder in the preliminary design phase.
- Develop requirements for vibration studies in detail design phase.

5.1.3.2 Internal Forces and Moments

While the external or free mass forces and moments are always transmitted through the engine seatings into the ship structure and directly effect the hull-girder response, the internal mass forces and moments directly disturb the engine frame, foundation and local structural supports. They are only retained as internal forces and moments if the foundation is infinitely rigid and the frame of the engine is designed to resist these forces and moments with minimum distortion. Ordinarily, the supporting structure in the ship is far from being rigid and some engine designs are more flexible than others. This could result in significant local vibration of plates and stiffeners and increase noise and maintenance problems.

To minimize the effects of internal forces and moments it is desirable to have maximum rigidity in the form of high moments of inertia of the engine bedplate and engine frame. In the preliminary design phase, the alternate engines under consideration should be evaluated for structural rigidity and recommendations obtained from the engine builder on the recommended construction of the engine foundation. It is likely that the manufacturer has foundation designs available, developed on the basis of their experience.

5.1.3.3 Lateral Moments

Lateral moments, also called guide force moments, are caused by the transverse forces acting on the crossheads, due to the connecting-rod/crankshaft mechanism and are the function of effects of combustion and inertia forces. They are dependent on the number of cylinders and the firing order and due to the irregularity of torque.

These lateral moments may produce rocking of the engine, generated by the H-moment, or twisting of the engine, generated by the X-moments, as shown in Figure 5-7, from Reference [5-5]. These moments will vary between engines, with variations of response dependent on engine and foundation rigidity.

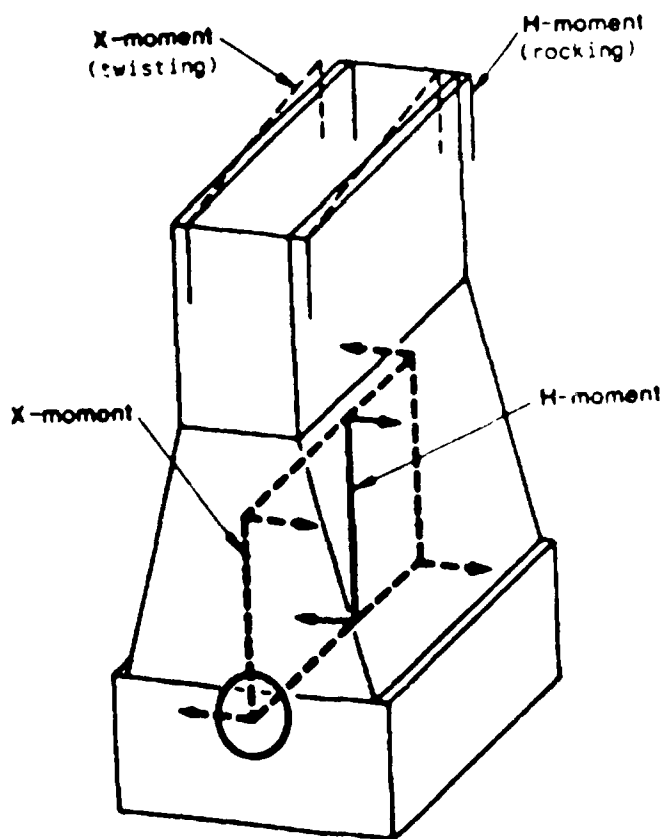

Figure 5-7
Effect of Lateral Moments on Engine Frame

Excessive lateral vibration of the low-speed diesel engine, used aboard ship, has been encountered on many occasions, requiring top bracings between the engine upper brackets and stiff structure of the hull. Initially, the top bracing was accomplished by direct connection to the engine but in later applications friction connections and hydraulic stays have been used, which would allow adjustments for the loading conditions of the ship. See Figure 5-8 as an example of hydraulic supports.

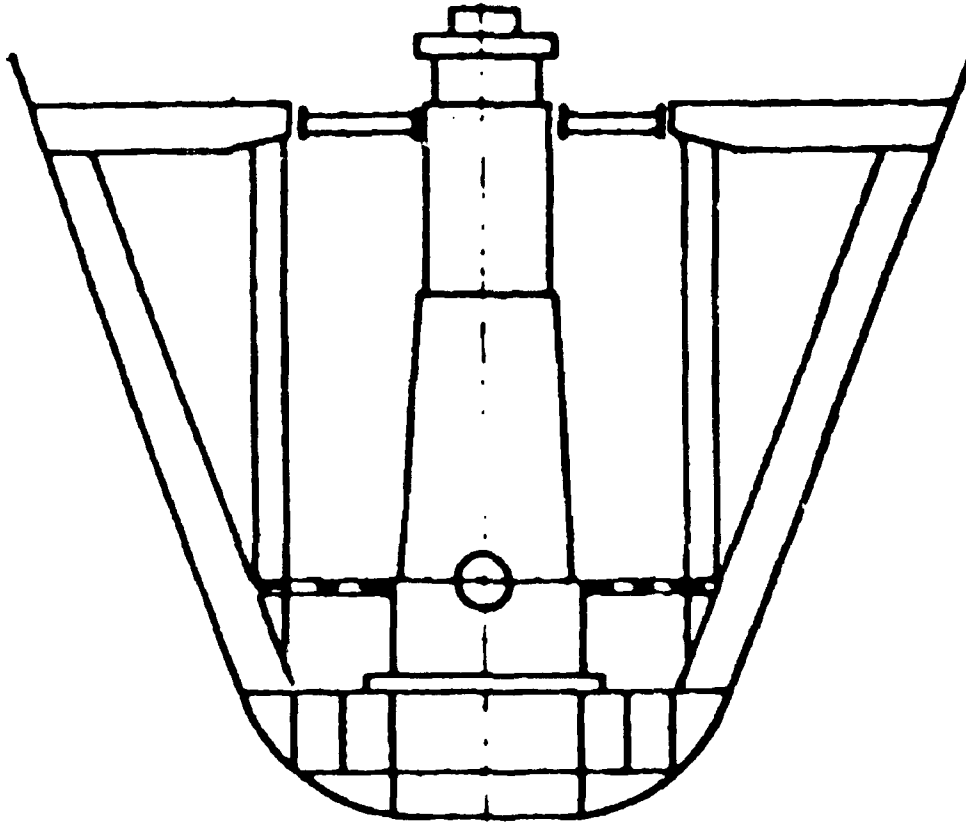

Figure 5-8

Installation of Hydraulic Stays Between Engine and Ship Structure

ISO 4867, "Code for measurement and reporting of shipboard vibration data," [5-7], includes the location and direction of vibration measurements to be made on low-speed diesels, during full-scale shipboard trials. Data of this type is needed on a number of ships, with alternate engines, engine foundations and inner bottom structures, to obtain a suitable basis for the evaluation of a proposed design. In this connection, the preliminary recommendations of engine builders, with such shipboard vibration experience, would be helpful.

5.2 Dynamic Shaft Stresses

In the development of the propulsion shafting design for commercial vessels, it is customary to follow the requirements of the classification society [5-8], for the determination of shaft dimensions, based on shaft strength characteristics. These requirements are reduced to the specified minimum diameters for the various shaft sections, based on shaft horsepower and RPM. When subjected to strong vibratory loads, more detailed analyses are generally required for review and evaluation, to insure serious criticals are adequately considered. These rules reflect current practice and are periodically updated, as necessary.

An alternate method is used by the Navy Department, [5-9], in which all steady and alternating stresses are combined, with suitable service factors, to obtain a factor of safety of two, when incorporated in a Goodman diagram. This procedure is preferred, for the detailed design phase, to insure serious torsional and longitudinal vibration criticals are avoided and/or meet the required design criteria.

As a result of a significant number of tailshaft failures occurring during and following WW II, an investigation on the cause of failure was undertaken by Panel M-8, "Investigation of Tailshaft Failures," under the sponsorship of SNAME. Full scale strain-gage studies were conducted on a number ships and laboratory fatigue studies were carried out under simulated shipboard environmental conditions. Results of the full scale studies were reported and proposed design criteria recommended to alleviate the effect of off-center thrust and operation in a corrosive environment, [5-10]. The Summary Report, [5-11], includes the results and recommendations emanating from this program. Several important factors were identified, which indicated that the tailshaft design was the most critical and would not necessarily be identified in detailed design analyses:

- Propeller thrust is eccentric to the shaft centerline.
- Tailshaft bending stress is generally the largest alternating stress.
- Surface cracks at keyways develop at points of high stress.
- Fatigue limits are greatly reduced in a corrosive medium.
- Corrosion fatigue is the major cause of tailshaft failures.
- Tailshaft alternating bending stresses should be limited to 6,000 psi
- Cold-rolling shafts will inhibit corrosion fatigue.

Based on these considerations and the results of the full-scale stress measurements, the maximum allowable alternating bending stress requirement has been included in Chapter Two, Section 2.3.1.2. It is considered prudent to include this requirement of the limiting tail shaft bending stress, which may indicate an increase in shaft dimension in the preliminary design phase to permit early modification to the shafting, if required and provide a better evaluation of the important longitudinal, lateral and torsional vibration design analyses by the use of the more correct shaft dimensions.

As pointed out in Reference [5-11], the Navy shaft design procedures were modified in 1960, [5-9] and design calculations generally tend to increase the minimum tailshaft diameters. This trend may also be noted in the changes in the ABS Rules [5-8], between 1971 and 1986.

5.2.1 Tailshaft Design

The preliminary design analysis developed for the 125,000 CM LNG Carrier, [5-12], is used to demonstrate the application of the limiting tailshaft bending stress of $\pm 6,000$ psi, as given in the criteria of Chapter Two, Section 2.3.2.1. As a first step, shaft diameters are determined by ABS Rule (1971) and compared with ABS Rule (1986). The minimum tailshaft diameter, obtained by the criteria given in Chapter Two is then compared the ABS Rule and the Navy Criteria [5-9].

Engineering data and assumptions used in the original study, are:

Maximum SHP	45,000
Maximum RPM	100
Propulsive Thrust	526,400 lbs
Propeller Weight	122,650 lbs (in air)
Propeller Diameter	24.5 ft
Propeller BAR	0.9
Number of Blades	5
Propeller MR ²	1.69 x 10 ⁶ lb-in-sec ² (incl. entrained water)

Machinery Weights:

LP Turbine	80,800 lbs
HP Turbine	42,500 lbs
Condenser	160,000 lbs. (wet)
Bull Gear	87,000 lbs
Reduction Gear (Total)	310,000 lbs

Line Shaft Diameter: (Based on ABS Rule, 1971)

$$\begin{aligned}
 D &= C \sqrt[3]{\frac{KH}{R}} \\
 &= 0.875 \sqrt[3]{\frac{64 \times 45,000}{100}} \\
 &= 26.86 \text{ inches} \approx 27.0 \text{ inches}
 \end{aligned}$$

where:

Ship Vibration Design Guide

$$H = 45,000 \text{ SHP}$$

$$K = 64$$

$$R = 100 \text{ RPM}$$

$$C = 0.875$$

Thrust Shaft Diameter:

$$\begin{aligned} D &= C \sqrt[3]{\frac{KH}{R}} \\ &= 1.05 \sqrt[3]{\frac{64 \times 45,000}{100}} \\ &= 32.25 \text{ inches} \end{aligned}$$

where:

$$H = 45,000 \text{ SHP}$$

$$K = 64$$

$$R = 100 \text{ RPM}$$

$$C = 1.05$$

Tailshaft Diameter: (1971 ABS Rule)

$$\begin{aligned} T &= 1.14D + \frac{P}{C} \text{ in} \\ &= 1.14 \times 27 + \frac{294}{144} \\ &= 32.82 \text{ inches} \approx 33.0 \text{ inches} \end{aligned}$$

where

$$D = 27 \text{ inch line shaft diameter}$$

$$P = 294 \text{ inch propeller diameter}$$

$$C = 144$$

Tailshaft Diameter: (1986 ABS Rule)

$$D = 100K \sqrt[3]{\frac{H}{R} \times \frac{3.695}{U + 23,180}}$$

where:

$$K = 1.26$$

$$H = 45,000$$

$$R = 100$$

$$U = 60,000$$

$$D = 34.25 \text{ inches}$$

Check on Bending Stress (6,000 psi max.)

The method of selecting the section modulus for a maximum bending stress of 6,000 psi will be that recommended by Noonan, reference [5-10]

$$Z = \frac{C (M_g + M_t)}{6,000} \text{ in}^3$$

where:

- Z = Section Modulus, in³
- C = Service Factor = 1.75
- M_g = Gravity Moment, in-lb
- M_t = Off-Center Thrust Moment, in-lb

A moment arm of 44 feet between the C_G of the propeller and the point of maximum shaft stress at the forward face of the propeller is assumed.

$$M_g = 122,650 (44) = 5.4 \times 10^6 \text{ in-lbs}$$

$$M_t = 0.065 (D_p) (T)$$

where:

- D_p = Propeller Diameter = 294 inches
- T = Maximum Propulsive Thrust = 526,400 lbs
- M_t = $0.065 (294) (526,400) = 10.06 \times 10^6 \text{ in-lbs}$
- $(M_t + M_g)$ = $15.46 \times 10^6 \text{ in-lbs}$

$$Z = \frac{1.75 \times (15.46 \times 10^6)}{6000} = 4,520 \text{ in}^3$$

$$D = \sqrt[3]{\frac{32Z}{\pi}} = \sqrt[3]{\frac{32(4520)}{\pi}} = 35.9 \approx 36 \text{ inches}$$

Since the ABS Tailshaft size of 33 inches is too small compared to that required for a maximum ± 6000 psi bending stress, a tailshaft diameters 36 inches will be used.

The above results of the various shaft diameters and the preliminary arrangement of shafting shown in Figure 5-9 suggest that only two basic shaft diameters be considered; 36 inches for the Tailshaft and 32.25 inches for the thrustshaft, lineshaft and stern tube shaft, for preliminary design purposes.

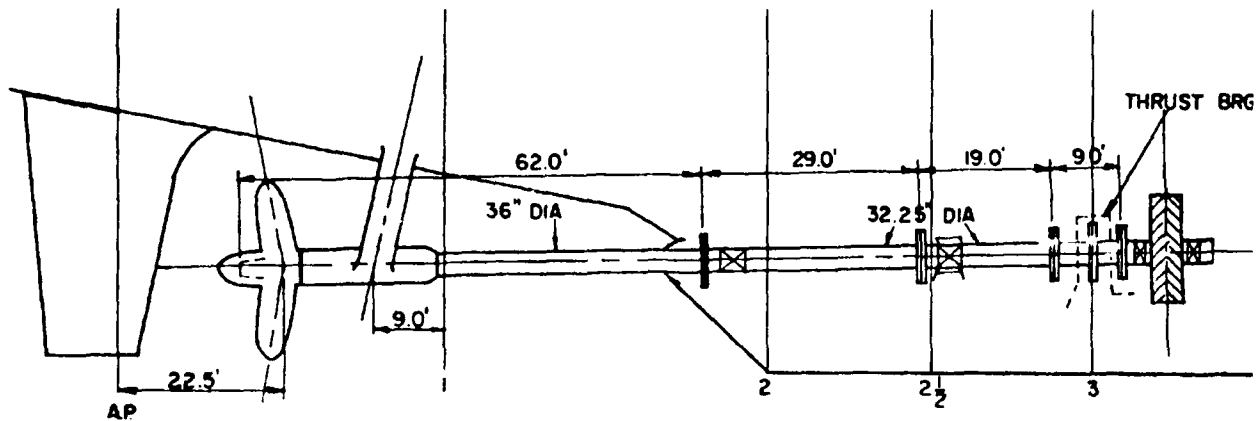

Figure 5-9

Preliminary Shafting Arrangement for LNG Project Hull

Tailshaft Diameter by Navy Calculation, [5-9]

For single-screw vessel, solid shaft:

$$M_g = 5.4 \times 10^6 \text{ in-lbs (from previous calculations)}$$

$$M_p = 3M_g = 16.2 \times 10^6 \text{ versus } 15.46 \times 10^6 \text{ in-lbs}$$

$$Z = \frac{1.75 \times 15.46 \times 10^6}{6,000} = 4509 \text{ in}^3$$

$$D = \sqrt[3]{10.2 \times 4509} = 35.85 \approx 36 \text{ inches}$$

The above analysis indicates that the minimum tailshaft diameter, determined by ABS Rule, increased from 33 inches obtained by the 1971 Rule to 34.25 inches obtained by the 1986 Rule. This increase reflects the influence of the studies conducted by the SNAME M-8 Panel, as discussed in References [5-10] and [5-11]. The application of the recommended criteria [5-10] and the Navy Criteria of 1960 [5-9] both indicate, for the LNG design, a minimum tail shaft diameter of 36 inches. While this analysis is considered conservative based on the author's experience, it was derived from the limited data available at the time.

As shown in Figure 5-9, the 36 inch diameter was used for the tailshaft and the 32.25 inch diameter was used for the thrust shaft, as indicated by the ABS Rule. This diameter was also

used for the line shaft and stern-tube shafts. Thus, Figure 5-9 is applicable for the shafting vibration analyses shown later. This portion of the preliminary design analysis will generally be the controlling factor in the development of the shafting design, due to the importance of the thrust eccentricity, the high alternating bending stress developed, and the low corrosion fatigue properties of the shaft.

5.2.2 Thrust Eccentricity

It was shown in Reference [5-13] that there are three principal contributions to the resultant shaft bending moment:

- (a) The moment due to eccentric thrust
- (b) The moment due to gravity
- (c) The moment due to the propeller torque reaction

It was also shown that the thrust moment was significantly greater than the others and that the gravity moment was significantly greater than the torque moment. The combined stress pattern is the resultant stress produced by the above moments and their harmonics. It was also shown in the results of the tests conducted that the harmonic content of the combined stress pattern has relatively small importance. It was concluded that the first order stress roughly represents the stress produced by the combination of the moments referred to above and that its magnitude is a direct function of the phase relationship of the various vectors.

Studies were conducted on the phase relationship under various speed, load and sea conditions. Under maximum power, the first order bending stress was nearly out of phase with the gravity moment and over twice the magnitude of the gravity moment. Thus, the eccentric thrust produced a moment, roughly equal to three times the gravity moment. Detailed analyses and the development of the criteria, for the criteria, for the limited number of ships studied, are shown in Reference [5-10]. It was clearly established, however, that the thrust eccentricity is the most important factor to be considered in establishing the tailshaft diameter.

Of particular importance in the determination of alternating bending stresses in tail shafts, is the estimation of the thrust eccentricity factors for various ship types. For information and guidance, supplemental data on alternate stern configurations is included, as follows:

Figure 5-10 Stern Configurations and Wake Components for LNG Carriers

Figure 5-11 Thrust Eccentricity for Alternate LNG Stern Configurations

Thrust eccentricity varies according to the wake distribution. Since the Hogner stern accumulates wake in the upper and lower part of the propeller disc area, a low eccentricity factor is expected. The open-strut transom stern also shows a low eccentricity factor due to the high and uniform wake distribution and thus indicates the tailshaft bending stress calculations, based on the recommended criteria, to be conservative. The eccentricity shown for the conventional stern of approximately 15% of the propeller radius, or .075 times the propeller diameter would be of the same order of magnitude, but slightly higher than the average value of .065 obtained in the original test program and used in the criteria formula.

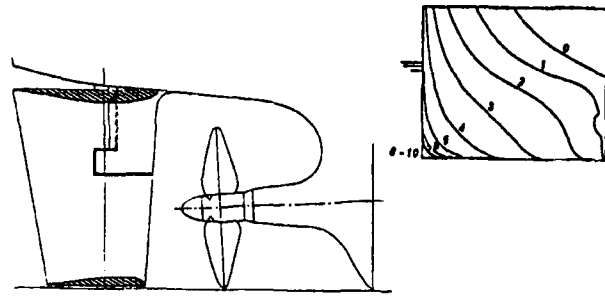

MODEL 4147 - Conventional Stern

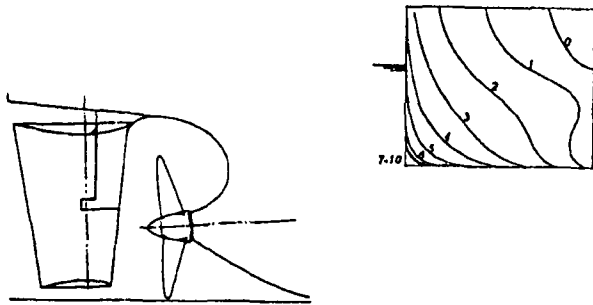

MODEL 4141 - Modified Hogner

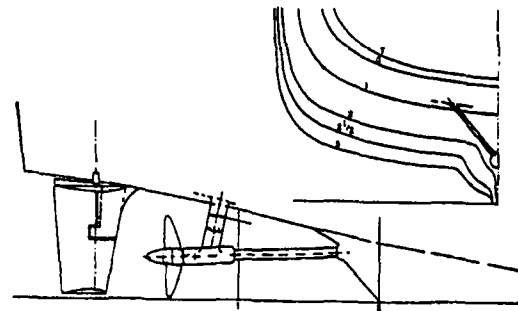
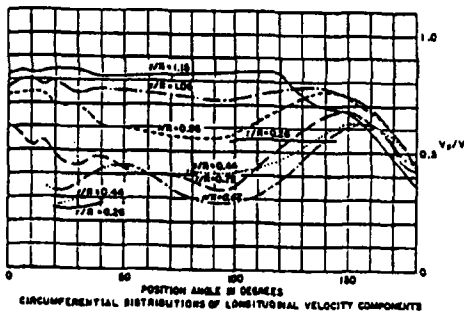
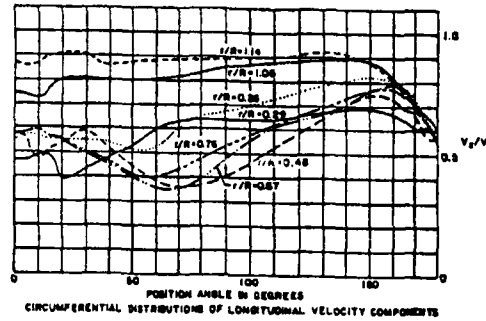

MODEL 4148 - Open Transom

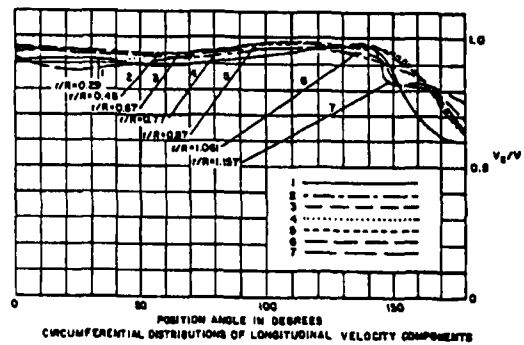

Figure 5-10

Stern Configuration and Wake Components for LNG Carriers

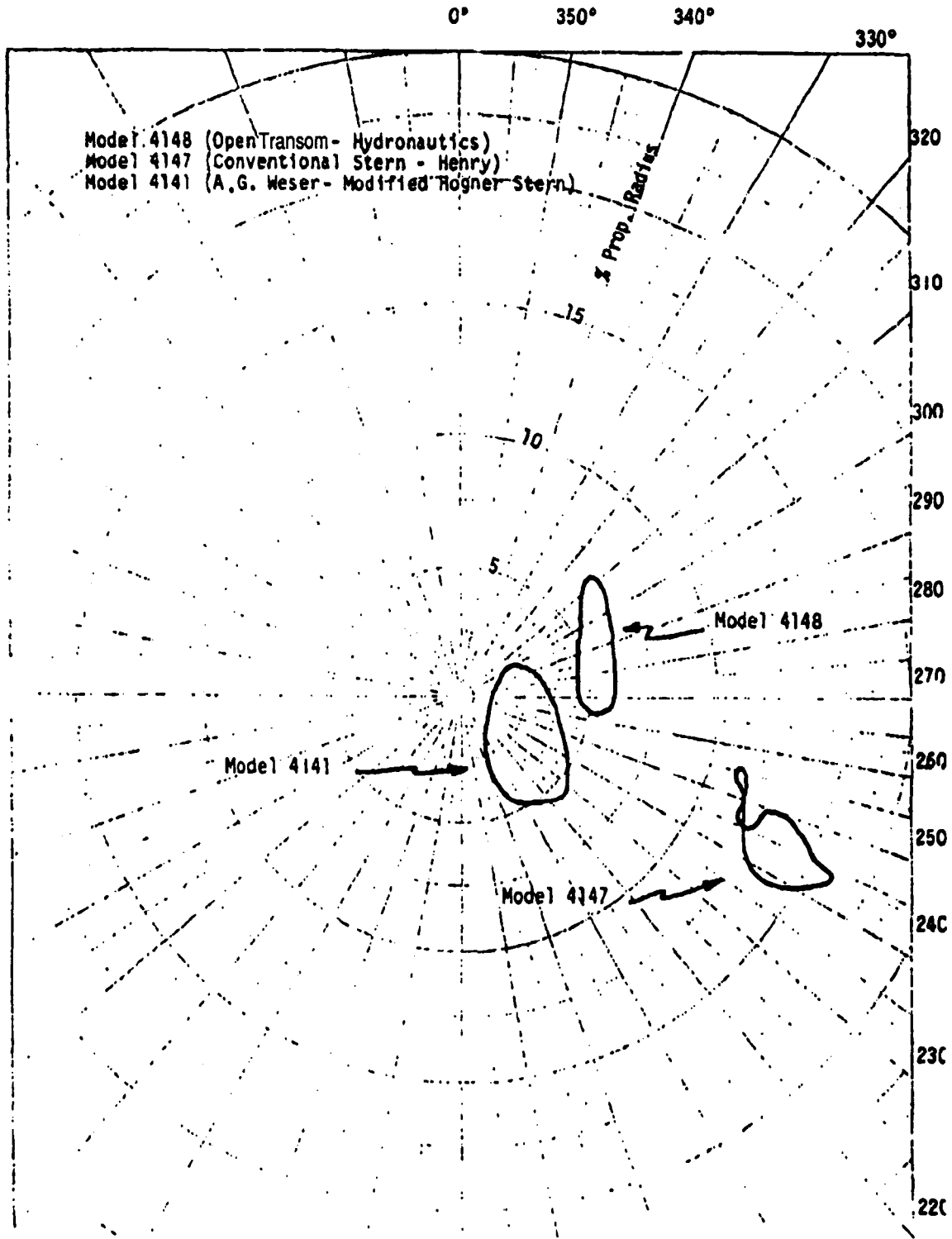

Figure 5-11

Ship Vibration Design Guide

Supplemental data, relative to the eccentric thrust obtained on single-screw vessels, for three stern types, is shown in Figure 5-12, from Reference [5-5]. It may be noted that the eccentricity for the "V" form, Intermediate form and "U" form, all fall between $.10R$ and $.15R$, or $.05D$ and $.075D$, which supports the criteria value of $.065$. Although the background for these data are not known, it would suggest that the "V" form would be the least preferred in regard to tailshaft bending stress.

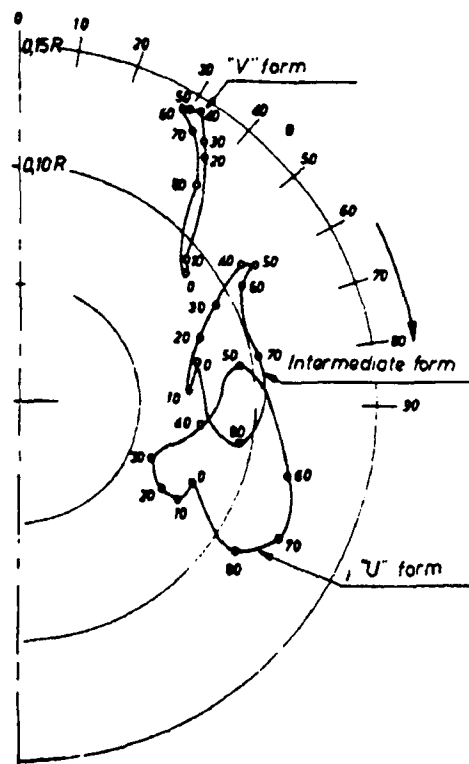
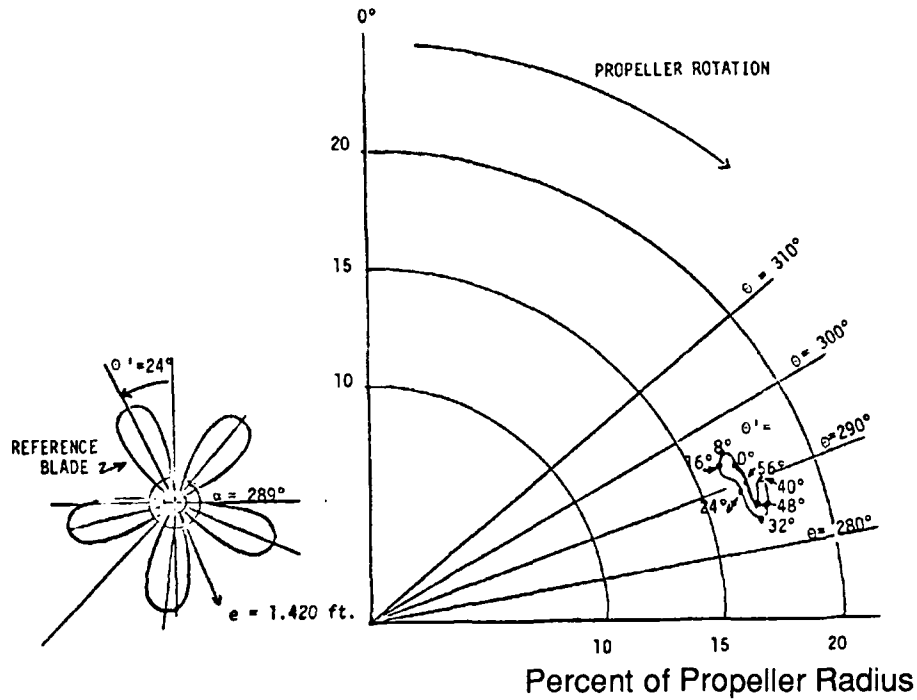

Figure 5-12

Values of Thrust Eccentricities for Three Stern Forms

When considering ships with two or more shafts, Figure 5-13 for a twin-screw Destroyer, Reference [5-14] and Figure 5-14 for the triple-screw Icebreaker, Reference [5-15], are shown. It is important to note that the eccentricity shown for the destroyer exceeds that associated with single-screw ships, used as the basis for the criteria given. It is also to be noted that the eccentricity shown for the wing propeller of the Icebreaker exceeded both the criteria value and that of the center propeller, which appears to fit the criteria. It is believed, however, that the high eccentricity value of the wing propeller was probably due to the heavy bossing used for ice protection. Significant modifications were recommended to improve the flow into the propellers, Reference [5-16], which would probably have reduced the eccentricity. At this point, however, the design was radically changed and no opportunity permitted verification of this assumption. It is assumed, however, with bossings the eccentricity of the wing propellers could still exceed that of the center shaft.



- θ = Angles of Blade Rotation, CCW ($0^\circ - 360^\circ$)
- θ' = 24° , Angular Blade Position of the Reference Blade ($0^\circ - 72^\circ$)
- α = 289° , Angular Eccentricity
- e = 1.42 ft, Radial Eccentricity
- e/R = 0.167, Eccentricity Factor

Figure 5-13

Polar Diagram of Thrust Eccentricity for Destroyer

5.2.3 Detail Design Considerations

Based on the limited research conducted on the design of propulsion shafting, we may conclude:

- Tailshaft bending, due to eccentric thrust, produce maximum dynamic stresses.
- Surface cracks and “fretting” originate in the keyway.
- Seawater frequently enters the propeller-hub and shaft cavity.
- Shaft fatigue limits are greatly reduced in a corrosive medium.
- Corrosion fatigue has been the primary cause of shaft failure.

Ship Vibration Design Guide

- High-strength alloy steels do not improve fatigue limits in seawater.
- Long stern-tube bearings exacerbates the thrust eccentricity.
- Current calculation methods are based on limited empirical studies.
- Reduction of propeller overhang will reduce thrust eccentricity.
- Cold rolling or shot-peening will inhibit corrosion fatigue.

During the detail design, it is important to consider stern-tube bearings, which permit the reduction of the propeller overhang, to carefully align the shaft to follow its natural slope and to consider cold rolling or shot-peening to inhibit corrosion fatigue. From a long range viewpoint, additional test data is required on alternate stern configurations and multiple-screw ships and improved procedures developed for shaft in design.

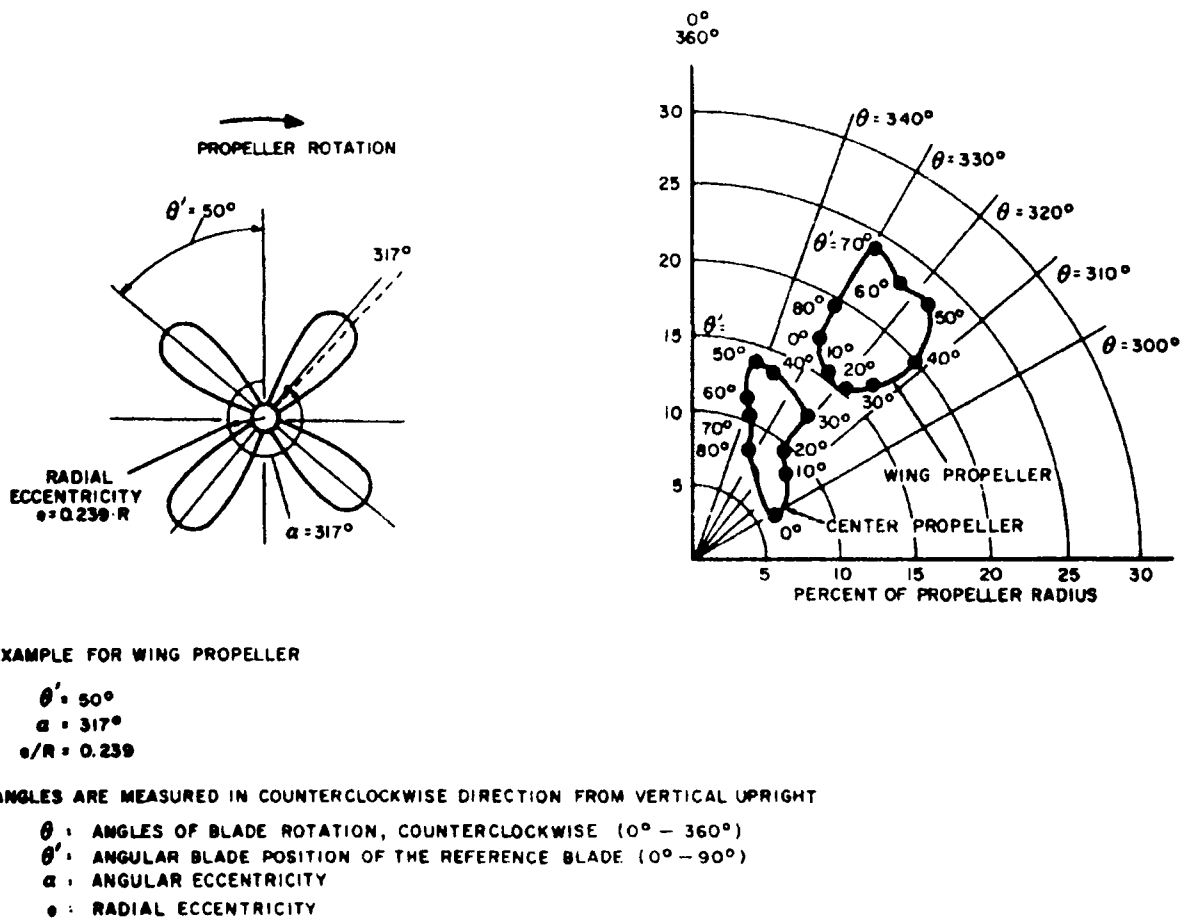

Figure 5-14

Polar Diagram of Thrust Eccentricity for Center and Starboard Wing Propellers (Four Blades)

5.3 Longitudinal Vibration of Propulsion Systems

Longitudinal vibration originating in the propulsion system can result in excessive vibration of the hull, deckhouse and superstructure; produce serious local vibration of turbines, condenser and piping; and result in failures in reduction gears, main thrust bearings and turbine thrust bearings. In most cases the excitation originates at the propeller and is magnified by resonances within the total shafting system. In this framework, the total shafting system includes the propeller, shafting, thrust bearing with its attachment to the hull, the reduction gear and engines. In the case of low-speed, direct drive diesels, the engine harmonics of torsional vibration may also generate longitudinal exciting forces through the coupling action of the propeller.

The mass-elastic system involved includes a number of components that may be readily calculated, such as propeller and shafting weights and shafting stiffness. The properties of other components, such as thrust bearings, turbines or high speed engines, may be obtained from potential suppliers or estimated from previously obtained data. Of major concern is the rigidity of the attachment to the hull, which requires some engineering judgment and calculation.

In the preliminary design phase it is necessary to develop a reasonable expectation of meeting the vibration criteria or specification and achieving the necessary compatibility between the vibration response characteristics of the hull and propulsion system. In this regard the proposed machinery arrangement (shafting design, engine selection and location), RPM and number of propeller blades must meet the longitudinal vibration criteria of Section 2.3.1.4 while the estimated hull response characteristics must meet the vibration criteria shown on Figure 2-1.

5.3.1 Longitudinal Vibration Analysis of the LNG Carrier

In the preliminary design analysis of the LNG Carrier, [5-12], the estimated vertical and horizontal hull frequencies, through the sixth mode, fell below the maximum blade-rate exciting frequency, when the ship is equipped with a five-bladed propeller, thus minimizing the potentially adverse influence of hull girder resonance. Although slightly lower forces were indicated for a six-bladed propeller, the higher blade-rate frequency would have compromised the longitudinal vibration characteristics of the propulsion system when we attempt to avoid longitudinal resonance of the propulsion system within the operating speed range.

In the development of the high powered LNG Carrier, three candidate hull forms, shown in Figure 5-10, were studied at the Netherlands Ship Model Basin (NSMB) and calculations of propeller forces, based on the NSMB data, were carried out. Results of the calculations, taken from Reference [5-12], are shown in Table 5-2. The calculations of the vibratory propeller-exciting forces support the preference for the open-strut transom stern, as represented by the Project Hull, for the generation of minimum vibratory forces.

The computed forces, shown in Table 5-2 for the Project Hull and the Conventional Hull are used in the longitudinal and torsional vibration analyses for the propulsion systems of each of these hulls. The engineering data and assumptions used in the original study, shown earlier in Section 5.2.1, are repeated here, for convenience. The machinery weights for the turbines, gears and condenser were furnished by the General Electric Company

Table 5-2 Results of Calculations of Propeller Forces Based on NSMB Data

	A. G. Weser Model 4141	Conventional Stern Model 4147	Open-Strut Model 4148
V_S , knots	20.00	19.00	20.00
D , feet	26.64	25.00	24.50
J	0.440	0.494	0.690
\bar{T} , lbs	635,800	472,900	451,600
T , lbs	± 39,760	± 31,820	± 17,520
T/\bar{T} , %	± 6.25	± 6.75	± 3.89
\bar{Q} , ft-lbs	2,370,000	1,754,000	2,053,358
Q , ft-lbs	± 97,470	± 88,780	± 56,660
Q/\bar{Q} , %	± 4.10	± 5.05	± 2.74
\bar{F}_H , lbs	- 5,300	- 9,980	- 3,700
F_H/\bar{F}_H , %	0.84	2.10	0.82
F_H , lbs	± 6,750	± 3,900	± 4,950
F_H/\bar{F}_H , %	± 1.06	± 0.82	± 1.11
\bar{F}_V , lbs	- 2,500	- 18,700	- 16,500
F_V/\bar{F}_V , %	0.40	4.00	3.66
F_V , lbs	+ 3,190	± 1,660	± 2,134
F_V/\bar{F}_V , %	± 0.50	± 0.35	± 0.47

Engineering data and assumptions used in the original study, are:

Maximum SHP	45,000
Maximum RPM	100
Propulsive Thrust	526,400 lbs
Propeller Weight	122,650 lbs (in air)
Propeller Diameter	24.5 ft
Propeller BAR	0.9
Number of Blades	5
Propeller MR^2	1.69×10^6 lb-in-sec ² (incl. entrained water)

Machinery Weights:

LP Turbine	80,800 lbs
HP Turbine	42,500 lbs
Condenser	160,000 lbs. (wet)
Bull Gear	87,000 lbs
Reduction Gear (Total)	310,000 lbs

The preliminary shafting arrangement for the Project Hull is shown in Figure 5-9. The preliminary shafting arrangement for the Conventional Hull is shown in Figure 5-16. Pertinent figures, taken from Reference [5-17], are included at the end of the LNG longitudinal vibration analysis. Additional information on the estimation of thrust bearing foundation stiffness may be obtained from SNAME T&R Report R-15, Reference [5-18].

5.3.1.1 Longitudinal Shaft Vibrations

The mass-elastic model for the longitudinal shaft vibration analysis, when assuming the propulsion machinery is installed on the same foundation as the thrust bearing, may be represented as follows:

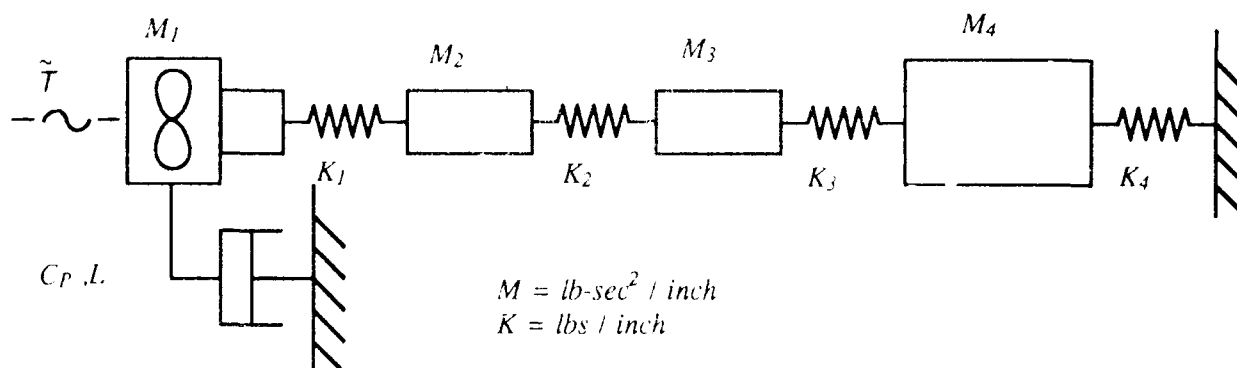

- M_1 = Propeller Mass + Entrained Water + $\frac{1}{2}$ Tailshaft Mass
- M_2 = Tailshaft Mass + $\frac{1}{2}$ of Other Shafting up to Thrust Bearing
- M_3 = Balance of Shafting Mass + Bull Gear Mass
- M_4 = Turbines, Reduction Gear (less bull gear), Condenser and foundation structure - lever effect to be considered
- K_1 = Tailshaft Stiffness
- K_2 = Stern Tube, Line and Part of Thrust Shaft Stiffness
- K_3 = Thrust Bearing Stiffness (elements and housing)
- K_4 = Machinery Foundation Stiffness
- \tilde{T} = Alternating Propeller Thrust, \pm lbs

C_p, L = Equivilant Propeller Damping Constant, lb-sec / in

$$M_1 = \frac{\left[122,650 \times 1.5 + \frac{290 \times 678}{2} \right]}{386} = 731 \text{ lb-sec}^2 / \text{in}$$

$$M_2 = \frac{\left[290 \times 678 + \frac{232 \times 684}{2} \right]}{386} = 460 \text{ lb-sec}^2 / \text{in}$$

Ship Vibration Design Guide

$$M_3 = \frac{\left[\frac{232 \times 684}{2} + 87,000 \right]}{386} = 431 \text{ lb-sec}^2 / \text{in}$$

$$M_4 = \frac{607,300}{386} = 1,570 \text{ lb-sec}^2 / \text{in}$$

where:

HP Turbine	42,500 lbs
LP Turbine	80,800
Condenser (wet)	160,000
Reduction Gear (less bull gear)	223,000
Foundation (20% of above)	<u>101,000</u> 607,300 lbs

In view of the lever effect, which causes the machinery masses above shaft level to experience larger longitudinal displacement (see reference [5-17]) the effective height of the overall machinery mass will be assumed as being 1.4 times higher than the shaft centerline. This results in an increase of the machinery mass by a factor of $(1.4)^2$.

Therefore:

$$M_4 = (1.4)^2 (1,570) = 3,080 \text{ lb-sec}^2 / \text{in}$$

$$K_1 = \frac{AE}{L}$$

$$K_2 = \frac{1020 \times 30 \times 10^6}{678} = 45.1 \times 10^6 \text{ lbs / in}$$

$$K_3 = \frac{817 \times 30 \times 10^6}{630} = 38.9 \times 10^6 \text{ lbs / in}$$

The overall thrust bearing stiffness, K_3 is found by a series combination of the housing and elements stiffnesses. The stiffness of the thrust elements is estimated to be 42×10^6 lb/in, from the G.E. data. The housing and support stiffness will be estimated from Figure 4 of Reference [5-17]. Since this figure does not cover the thrust value of the LNG, an upper and lower estimate will be made, i.e., 23×10^6 and 15×10^6 lb/in respectively.

Therefore:

$$K_3 = \frac{1}{\frac{1}{42 \times 10^6} + \frac{1}{23 \times 10^6}} = 14.9 \times 10^6 \text{ lbs / in}$$

or:

$$K_3 = \frac{1}{\frac{1}{42 \times 10^6} + \frac{1}{15 \times 10^6}} = 11.1 \times 10^6 \text{ lbs / in}$$

In a similar manner, the foundation stiffness, K_4 , will also have to be estimated since Figure 6 of [5-17] does not cover the propulsive thrust of the LNG. Therefore, an upper value of 30×10^6 lb/in and a lower value of 20×10^6 will be considered to cover the range of the LNG foundation stiffness. Although no foundation details are available at this time, inspection of Figure 5-9 suggests that the foundation will be rather short and is in a relatively small space since it is still in the confines of the "bulb." Two studies were therefore conducted, one with the lower values of K_3 and K_4 and another with the higher values. The results of the frequency analyses are shown in Figure 5-15.

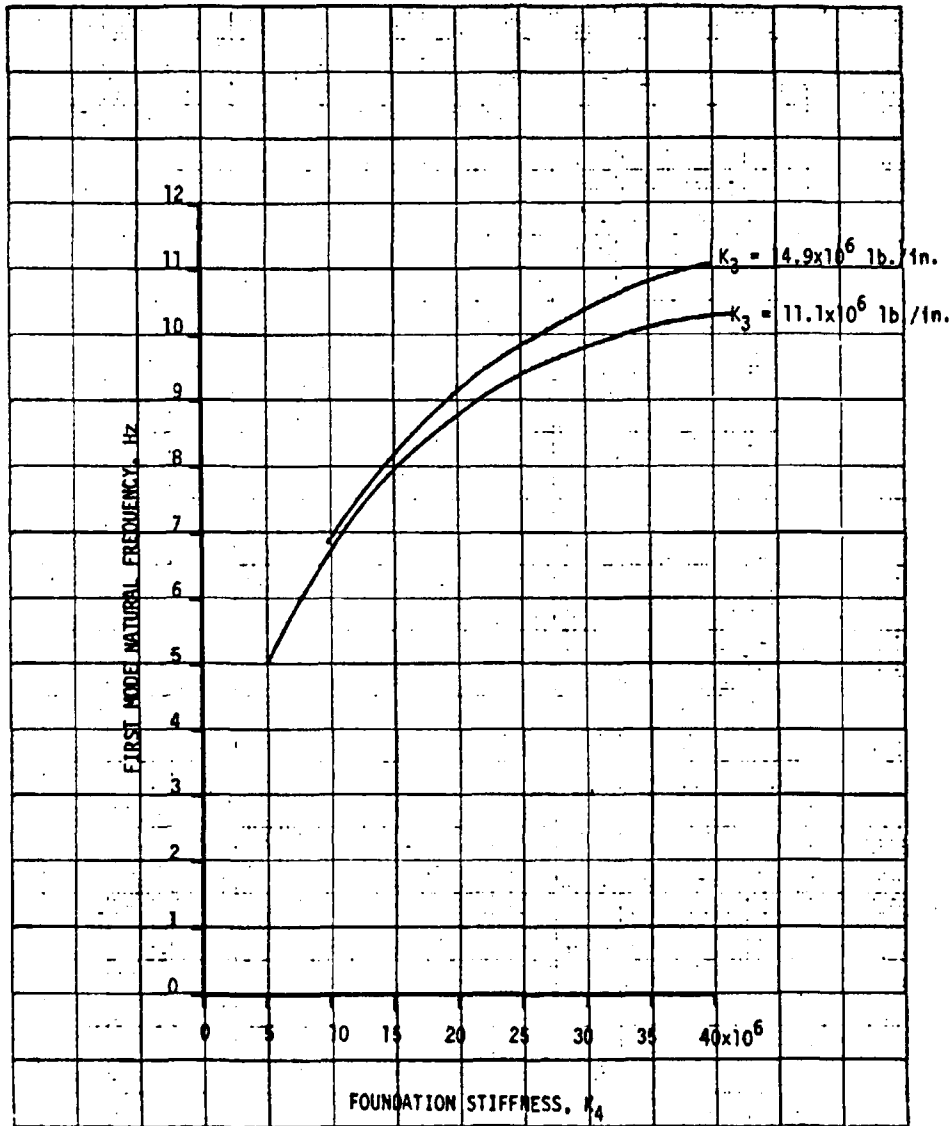

Figure 5-15

First Mode Frequency versus Thrust Bearing Stiffness (K_3) and Foundation Stiffness (K_4) for Project Hull

5.3.1.2 Comments

In this analysis, K_3 represents the thrust bearing stiffness (elements and housing). In calculating this value, the stiffness of the elements, as given by GE, (42×10^6 lb/in.) are combined with the estimated thrust bearing housing and its immediate support bracket, as deduce from Figure 4 of Reference [5-17]. Thus, the estimated range of 15 to 23×10^6 lb/in, as used in this analysis, results in a much lower stiffness value for the "housing" than is given for a comparative Michell bearing (73×10^6 lb/in). However, the "foundation" stiffness range of 20 to 30×10^6 lb/in, as taken from Figure 6 of Reference [5-17] is, as would be expected, correspondingly higher since it does not include the immediate support bracket for the thrust bearing.

For comparison purposes, the total thrust bearing housing and foundation stiffness for the LNG using the stiffness value estimates from Figures 4 and 6 of Reference [5-17] are compared with the value obtained for the Sea Land SL-7 design.

LNG Low Foundation Stiffness (Including Housing)

$$K_{FL} = \frac{1}{\frac{1}{K_1} + \frac{1}{K_2}}$$

where:

$$K_1 = \text{Housing and Support} = 15 \times 10^6 \text{ lb / in}$$

$$K_2 = \text{Foundation} = 20 \times 10^6 \text{ lb / in}$$

$$K_{FL} = \frac{1}{0.067 + 0.05} = 8.55 \times 10^6 \text{ lb / in}$$

LNG High Foundation Stiffness (Including Housing)

$$K_1 = 23 \times 10^6$$

$$K_2 = 30 \times 10^6$$

$$K_{FH} = \frac{1}{0.0435 + 0.033} = 13 \times 10^6 \text{ lb / in}$$

Average LNG Foundation Stiffness (Including Housing)

$$K_{FA} = \frac{8.55 + 13.0}{2} \times 10^6 = 10.77 \times 10^6 \text{ lb / in}$$

Sea Land SL-7 Foundation and Housing Stiffness

$$K_F = \frac{1}{\frac{1}{K_1} + \frac{1}{K_2}}$$

$$= \frac{1}{0.0835 + 0.0139} = 10.3 \times 10^6 \text{ lb / in}$$

where:

$$K_1 = \text{Housing and Support} = 73 \times 10^6 \text{ lb / in}$$

$$K_2 = \text{Foundation} = 12 \times 10^6 \text{ lb / in}$$

Thus, the average value for the LNG compares very well with that computed for the Sea Land SL-7. However, since the SL-7 employs a much larger shaft, which places the thrust foundation on the tank top, presumably the LNG design would more closely be represented by the upper value of foundation stiffnesses. If, in addition, a stiffer thrust bearing, as represented by the Michell, which provides a line support for the thrust block rather than a point support, the fundamental frequency of the system would be expected to fall at 10.4 Hz, which would result in a 5th order critical of at least 125 RPM.

A second calculation was made, in which we assumed the propulsion machinery is not installed on the same foundation as the thrust bearing. The equivalent mass-elastic system is then taken as:

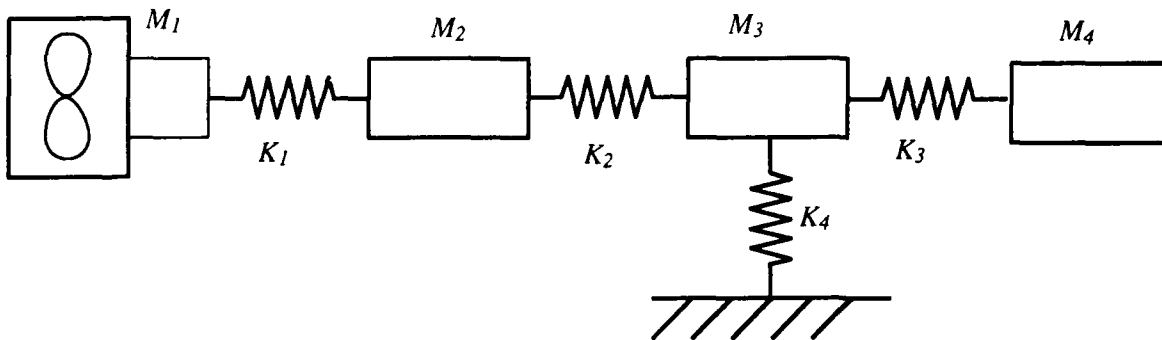

M_1	Mass of Propeller	122,650	$\frac{1}{g}$
	+ 50% for Entrained Water	61,325	
	+ Mass of $\frac{1}{2}$ Propeller Shaft (31 x 12 x 290)	<u>108,000</u>	
		292,000	

$$M_1 = 755 \text{ lb-sec}^2 / \text{in}$$

M_2	$\frac{1}{2}$ Propeller Shaft	108,000	$\frac{1}{g}$
	+ $\frac{1}{2}$ Line Shaft ((29 + 19) x 12 x 232) / 2	<u>67,000</u>	
		175,000	

$$M_2 = 455 \text{ lb-sec}^2 / \text{in}$$

M_3	$\frac{1}{2}$ Line Shaft	67,000	$\frac{1}{g}$
	+ Thrust Shaft (9 x 12 x 232)	23,000	
	+ Thrust Bearing (GE estimate)	68,000	
	+ $\frac{1}{4}$ Thrust Bearing Foundation (estimate = to TB)	<u>68,000</u>	
		226,000	

$$M_3 = 585 \text{ lb-sec}^2 / \text{in}$$

M_4	Gear Masses, Including Shafts (estimate)	100,00	$\frac{1}{g}$
-------	--	--------	---------------

$$M_4 = 260 \text{ lb-sec}^2 / \text{in}$$

Ship Vibration Design Guide

$$K_1 \text{ Stiffness of Propeller Shaft (from propeller centerline)} \\ = \frac{AE}{L} = \frac{1020 \times 30 \times 10^6}{678} = 45.1 \times 10^6 \text{ lb / in}$$

$$K_2 \text{ Stiffness of Line Shaft to Thrust Collar} \\ = \frac{817 \times 30 \times 10^6}{630} = 38.9 \times 10^6 \text{ lb / in}$$

$$K_3 \text{ Stiffness of Shaft from Thrust Collar to Bull Gear Centerline} \\ = \frac{817 \times 30 \times 10^6}{10.5 \times 12} = 195 \times 10^6 \text{ lb / in}$$

K_4 Stiffness of Thrust, including thrust housing and thrust foundation. Since we are interested in keeping the critical above the operating speed, we assume we use the Michell bearing. The rating for the bearing used on the Sea Land SL-7 is appropriate, although our shaft size is larger (32.5ins vs. 26.5ins). Thus it will be equal to or higher than that used on SL-7.

K_1 Internals	120×10^6 lb / in
K_2 Housing	73×10^6
K_3 Foundation	18×10^6 (The estimated value on the SL-7 was 12×10^6 when installed forward on tank tops-assume this foundation is 50% more)

$$K_4 = \frac{1}{\frac{1}{K_1} + \frac{1}{K_2} + \frac{1}{K_3}} = \frac{1}{0.0775} = 12.9 \times 10^6 \text{ lb / in}$$

For convenience, combine M_3 & M_4 . This is possible since the M_4 is relatively small and K_3 is relatively high. Thus:

$$M_3 = 845 \text{ lb / sec}^2 \text{ and } K_3 \text{ is eliminated.}$$

Table 5-3 Frequency Estimate (As a first approximation, assume frequency = 10 Hz; $\omega = 62.8$ rad/sec; $\omega^2 = 4,000$)

M	$M\omega^2/10^6$	X	$M\omega^2 X/10^6$	$\sum M\omega^2 X/10^6$	$K/10^6$	ΔX
755	3.02	1.000	3.02	3.02	45.1	.067
455	1.82	.933	1.69	4.71	38.9	.122
845	3.38	.811	2.74	7.45	12.9	.578
		-.578				
		.233				

Thus, using a K_4 of 12.9×10^6 would result in a higher frequency than 10 Hz. If we used the foundation stiffness of 12×10^6 , as was estimated for SL-7, the combined K_4 would be $= 1/.1053 = 9.5 \times 10^6$ lb/in.

Then, the last line of the above Holzer table would equal:

845	3.38	.811	2.74	7.45	9.5	.785
		-.785				
		.026				

The above analysis would indicate the system response would be largely controlled by the foundation stiffness, that the lowest frequency would result with the project hull, and that the fundamental longitudinal frequency of the system would be, at least 10 Hz, or 600 cpm. On this basis, a 5-bladed propeller would give a resonance at $600/5 = 120$ RPM or higher.

5.3.1.3 Frequency Analysis - Conventional Hull

The Preliminary Shafting Arrangement used for the Conventional Design, is shown in Figure 5-16. The schematic of the mass-elastic system is similar to that used for the Project Hull, except that the mass and stiffness values vary somewhat due to the shorter shaft. A comparison of the two sets of data is given, as follows:

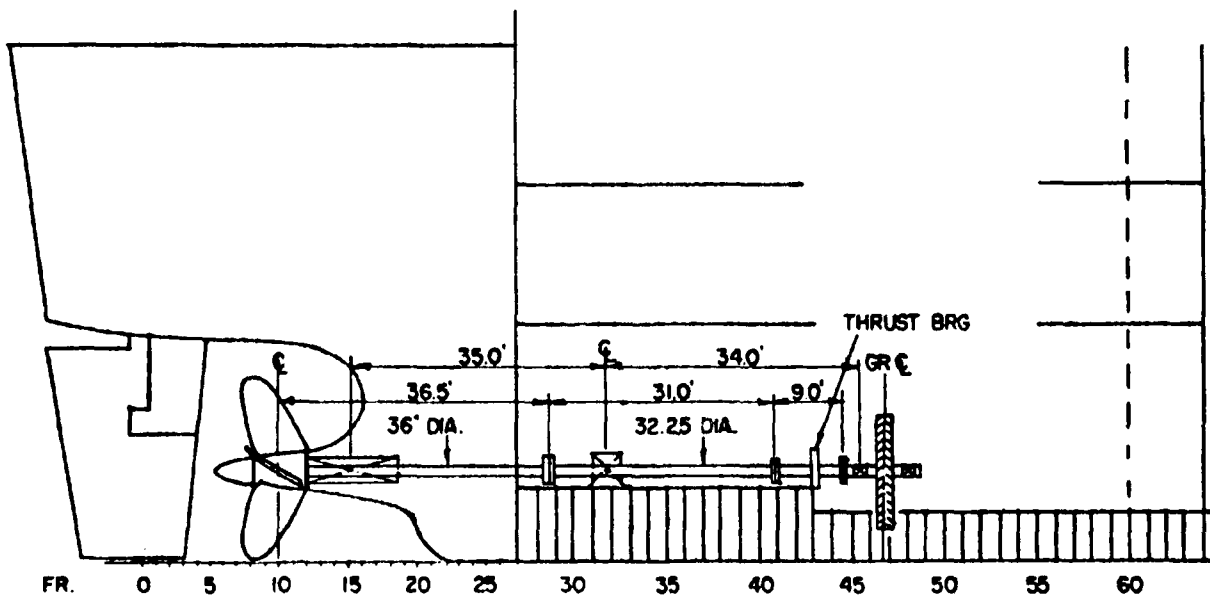

Figure 5-16

Preliminary Shafting Arrangement for LNG Conventional Design

Ship Vibration Design Guide

Parameter	Project Hull	Conventional Hull
M_1	731	641 lb-sec ² /in
M_2	460	277 lb-sec ² /in
M_3	431	337 lb-sec ² /in
M_4	3,080	3,080 lb-sec ² /in
K_1	45.1×10^6	69.8×10^6 lb/in
K_2	38.9×10^6	65.9×10^6 lb/in
K_3	11.1×10^6 to 14.9×10^6	11.1×10^6 to 14.9×10^6 lb/in
K_4	20×10^6 to 30×10^6	20×10^6 to 30×10^6 lb/in

Results of the computer analysis for the mass-elastic system of the Conventional Hull, is shown in Figure 5-17. Using the upper limits of K_3 and K_4 , as discussed under the frequency analysis for the Project Hull, the estimated frequency of the system is most likely to be in the vicinity of 11.5 Hz, with a 5th order critical occurring at $600/5 = 138$ RPM.

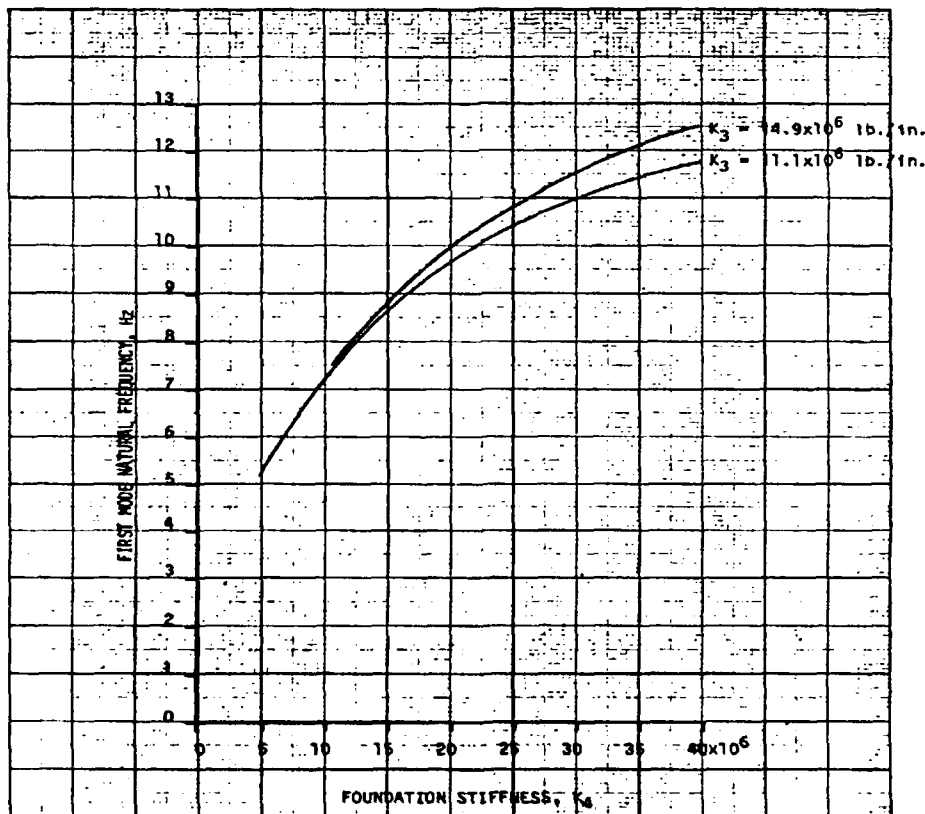

Figure 5-17

First Mode Frequency versus Thrust Bearing Stiffness (K_3) and Foundation Stiffness (K_4) for Conventional Hull

5.3.1.4 Response Calculations

In estimating the response of the mass-elastic systems to the estimated alternating thrust forces originating at the propeller, for both the Project Hull and the Conventional Hull, the forces (T) given in Table 5-2 were used, i.e., $\pm 17,520$ lbs for the Project Hull and $\pm 31,820$ lbs. for the Conventional Hull. The exciting force is assumed to vary as the square of the RPM, as the propulsive thrust does.

Of equal importance in estimating the system response, is the damping assumed. The equivalent damping constant at the propeller, C_p, L , was based on Figure 14 of Reference [5-17], which was developed from experimental data obtained on naval ships of smaller dimensions. In this instance the developed area of the propeller was estimated at (BAR) (Disc Area) = $.9 \times (\pi \times 24.5)^2 / 4 = 425 \text{ ft}^2$ and C_p, L was estimated to be 15,000 lb-sec / in.

Results of the computer analyses, for both the Project Hull and the Conventional Hull, are shown on Figure 5-18. Also shown is the allowable alternating thrust (50% of maximum full power thrust) as given in the proposed specifications prepared for the LNG carriers.

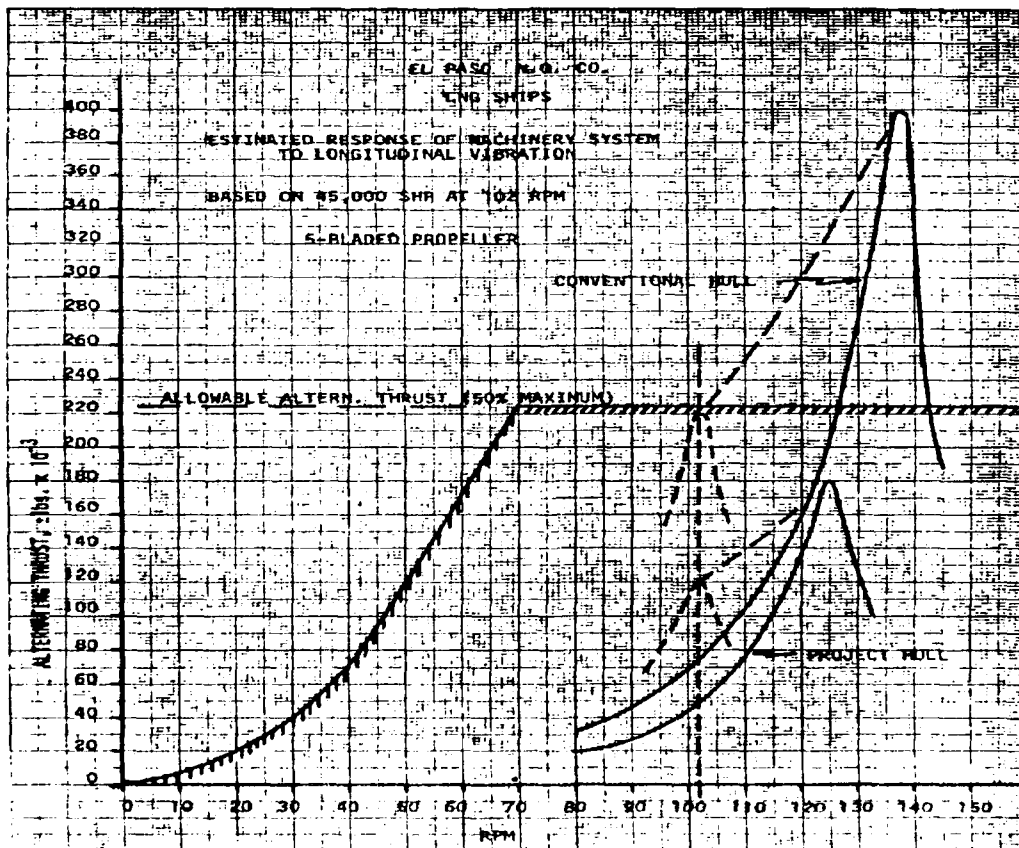

Figure 5-18

Estimated Response of Machinery System to Longitudinal Vibration

Ship Vibration Design Guide

An approximation of the anticipated severity of these criticals at 102 RPM, is shown by dotted line. The purpose of this estimate is to show the anticipated response, should the actual system parameters, as built into the ship, result in the critical actually falling at or near full power. The connecting dotted line shows the loci of resonant peaks at any RPM between full power and the calculated location of the critical.

It should be noted that the proposed specifications for the LNG Carriers were based on U.S. Navy requirements, Reference [5-19]. The criteria given in Chapter Two, Section 2.3.1.4 is more restrictive in regard to allowable alternating thrust at the main and turbine thrust bearings. The alternating thrust in this guide, is now considered excessive if it exceeds 75% of the mean thrust or 25% (as opposed to 50%) of the full power thrust, as given in Reference [5-19], whichever is smaller. The purpose of this limitation is to account for the signal modulation and sea conditions that result in a significant increase in the sinusoidal value obtained in the design analysis. As noted in Reference [5-17], a factor of two normally exists between maximum amplitudes and average or sinusoidal values obtained in calculations.

5.3.2 Longitudinal Critical Within the Operating Speed

The longitudinal vibration analysis is representative of the optimum shafting system in which it is possible to avoid the fundamental critical from occurring within the operating speed range. In some cases this is not possible and it is necessary to estimate the feasibility of the design by estimating the severity of the critical, evaluate the predicted response against the established criteria and the effect of this critical on the response of the hull. An alternate propeller or machinery arrangement may be required. The selection of the number of propeller blades and the skew angle of the blades can have a significant impact on the total ship and machinery vibration.

The seriousness of the longitudinal vibration characteristics of the propulsion system, particularly when reduction gears are employed, cannot be underestimated. While we are primarily concerned with the fundamental critical and its response to blade-rate vibratory forces, harmonics of blade-rate must also be considered along with the higher frequencies of vibration of the total system, including the shafting and bull-gear web (structural flexibility). Thus, having established the omission or safety of the fundamental critical in the preliminary design phase, it is necessary to have more detailed analyses conducted, as early as possible, in the detail design phase. This study is normally included in the contractual responsibility of the gear builder, or in the case of diesel engine drive systems, by the engine builder. They should be required to submit detailed design studies to insure compliance with the criteria or specifications invoked. It is also important that the contract price include this effort.

5.3.2.1 Frequency Analysis

In the preliminary design phase, which is primarily dependent on empirical data, we necessarily turn to DTRC for the limited available data required. In this instance Reference [5-17] provides a typical analysis for a turbine-drive system, for which the following example is developed. The figure numbers used in the original report [5-17] are retained for reference convenience.

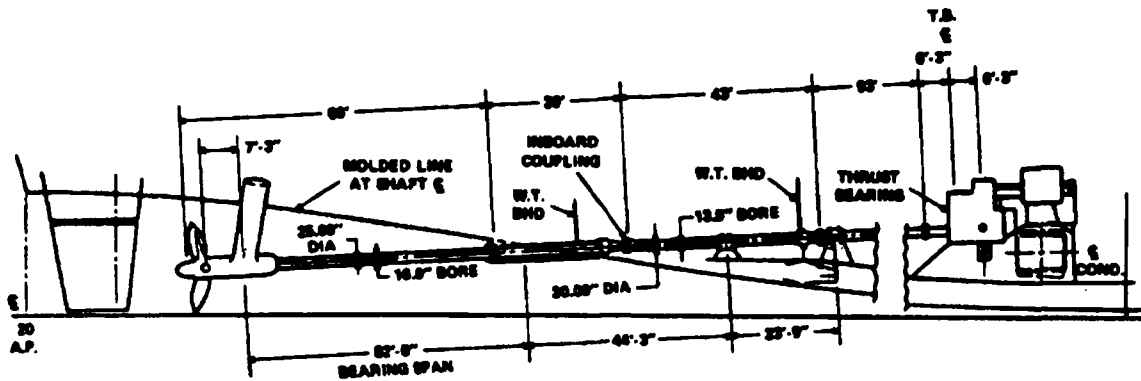

Figure 18
Shafting Arrangement

The shafting arrangement for the sample problem is shown in Figure 18. The machinery characteristics and related engineering data, are as follows:

Maximum SHP	30,000 (single-screw)
Maximum RPM	130
Maximum thrust	300,000 lb

Component weights (in pounds) are as follows:

Reduction gear (total)	131,000
Bull gear and shaft	38,500
Second reduction pinions	7,000
Low-pressure turbine	30,000
High-pressure turbine	25,000
Condenser (wet)	60,000
Foundation structure	60,000
Propeller (in air)	50,000
Propeller shaft	65,850
Stern tube shaft	29,150
Line shafting	82,900

Ship Vibration Design Guide

A four-mass, four-spring, mass-elastic model will be developed as shown:

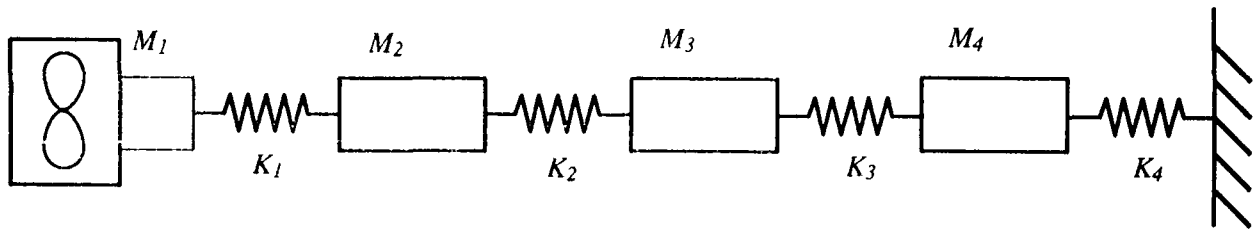

where:

M_1 is the mass of the propeller and entrained water plus one-half of the mass of the propeller and stern tube shafts in pound-seconds² per inch (50 percent of propeller weight is nominally taken for the entrained water),

M_2 is one-half the mass of the propeller and stern tube shafts plus one-half the mass of the line shafts in pounds-seconds² per inch,

M_3 is one-half the mass of the line shafts plus bull gear plus second reduction pinions in pound-seconds² per inch, and

M_4 is the effective mass (including lever effect) of the reduction gear, (less bull gear and second reduction pinions) low- and high-pressure turbines, condenser and foundation in pound-seconds² per inch.

K_1 is the combined stiffness of the propeller and stern tube shafts in pounds per inch,

K_2 is the stiffness of the line shafting in pounds per inch,

K_3 is the stiffness of the thrust bearing elements and housing in pounds per inch, and

K_4 is the stiffness of the foundation/hull structure in pounds per inch

The mass parameters are computed as follows:

$$M_1 = \left[\frac{50,000 + (0.5 \times 50,000) + \frac{65,850 \times 29,150}{2}}{386} \right] = 317 \text{ lb-sec}^2 / \text{in}$$

$$M_2 = \left[\frac{\frac{65,850 + 29,150}{2} + \frac{82,900}{2}}{386} \right] = 230 \text{ lb-sec}^2 / \text{in}$$

$$M_3 = \left[\frac{\frac{82,900}{2} + 38,500 + 7000}{386} \right] = 225 \text{ lb-sec}^2 / \text{in}$$

The machinery and foundation mass M_4 will be computed to include the lever effect of the individual components. The lever effect is the tendency for the components of the propulsion machinery, above the shaft level, to have increased vibratory amplitudes. This effect has been observed on all reported measurements.

To compute the effective foundation mass M_4 , the component weights and the location of the center of gravity above the inner bottom must be known first. Figure 19 gives the computation to account for the lever effect on the machinery/foundation mass; the equivalent value of M_4 referred to shaft level is found to be 1003 lb-sec²/in.

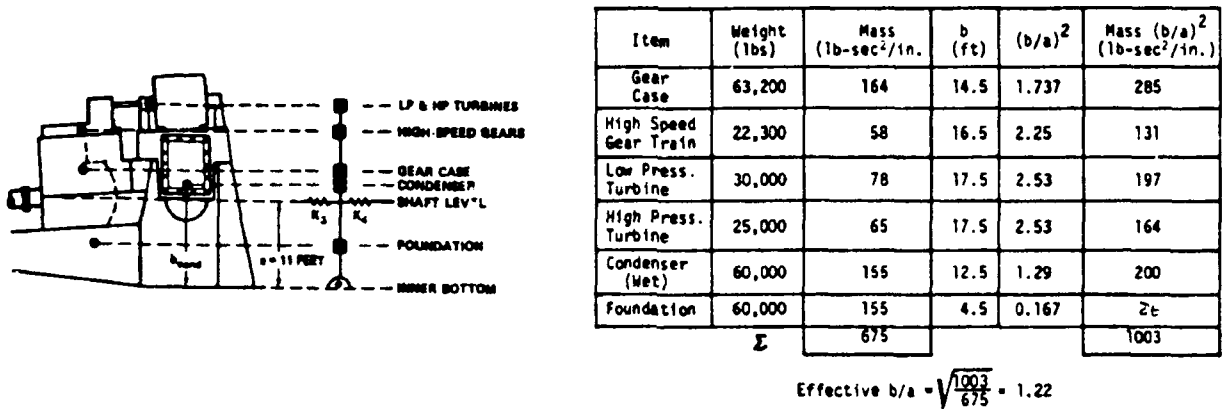

Figure 19

Lever Effect Representation of Example Problem Foundation Mass M_4

The stiffness parameters for the propulsion shafting are computed by the expression:

$$K = \frac{AE}{L} \text{ lbs / in}$$

where:

- A is the cross-sectional area of the shaft in square inches,
- E is Young's modulus for shaft material in pounds per square inch,
- L is the length of shaft of constant cross-section in inches,

$$K_1 = \frac{\pi (25^2 - 16^2) (29 \times 10^6)}{4 \times 1154} = 7.28 \times 10^6 \text{ lbs / in}$$

$$K_2 = \frac{\pi (20^2 - 13.5^2) (29 \times 10^6)}{4 \times 1707} = 2.91 \times 10^6 \text{ lbs / in}$$

Ship Vibration Design Guide

To estimate the thrust bearing stiffness K_3 from figures 4 and 5, the propulsive thrust at the resonant speed must first be known. This amounts to making a preliminary estimate of the first-mode natural frequency and determining the critical shaft speed. The propulsive thrust at the resonant speed may then be obtained using the square-law and full-power thrust.

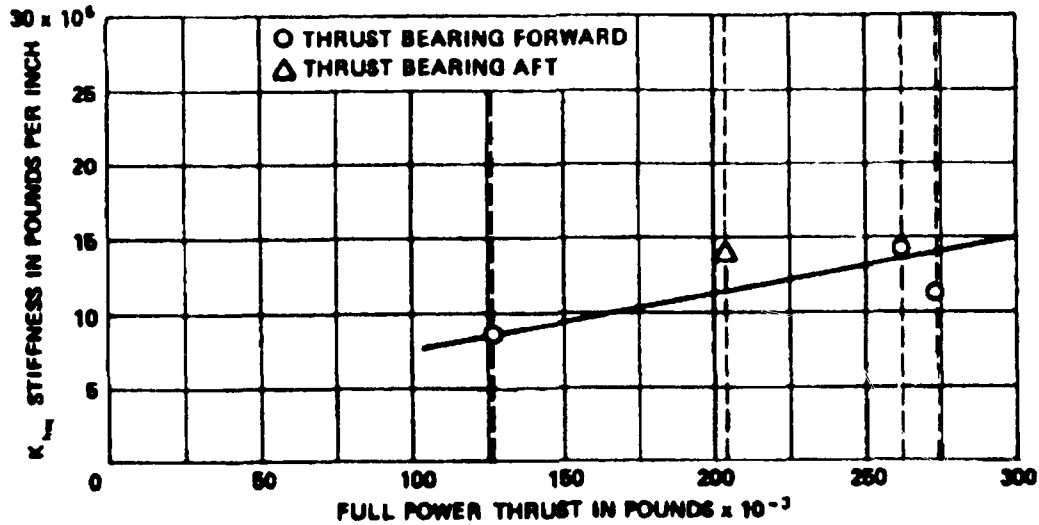

Figure 4

Stiffness of Thrust Bearing Housing and Support versus Full Power Thrust

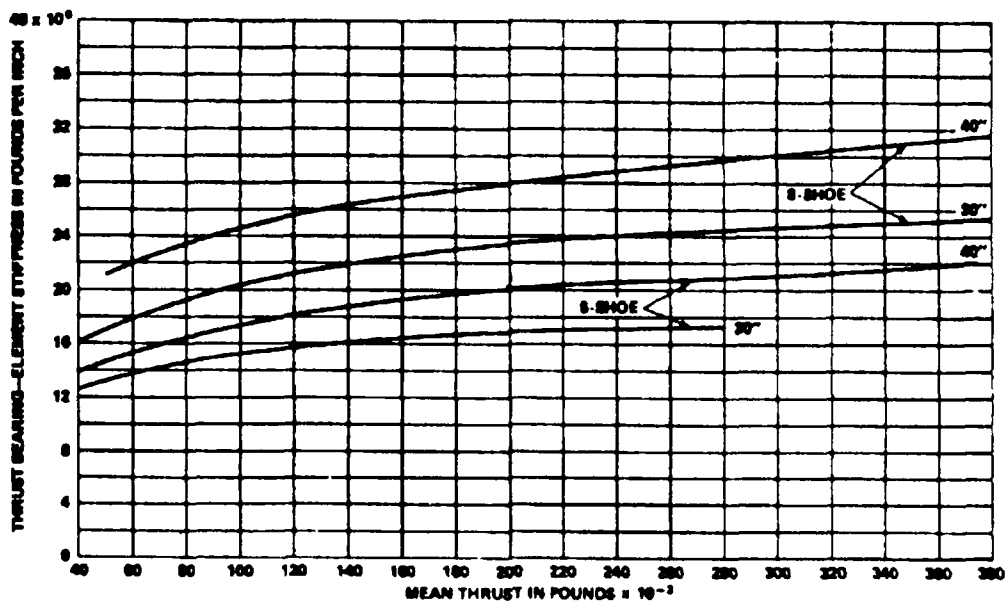

Figure 5

Stiffness of Kingsbury Thrust Bearing Elements as Calculated by Kingsbury

Figure 20 shows a quick method for obtaining a preliminary estimate of the first-mode natural frequency. Other similar methods have been published but they use shaft length as an input to the curve for determining the flexibility factor and do not differentiate between hollow or solid shafting. In contrast, the method of Figure 20 enables either hollow or solid shafting to be considered.

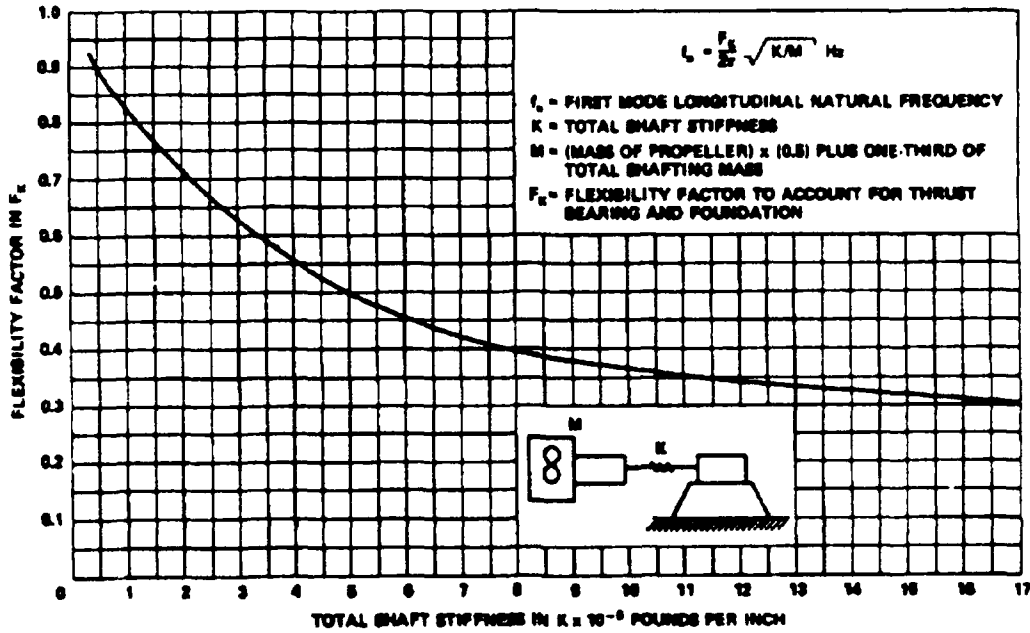

Figure 20
Preliminary Method for Determining First-Mode Longitudinal Frequency

The overall shaft stiffness in the sample problem is:

$$\frac{1 \times 10^6}{\frac{1}{7.28} + \frac{1}{2.91}} = 2.08 \times 10^6 \text{ lbs / in}$$

which from Figure 20 results in a flexibility factor, F_k of 0.71.

$$M = \left[\frac{50,000 \times 1.5 + \frac{65,850 + 29,140 + 82,900}{3}}{386} \right] = 348 \text{ lb-sec}^2 / \text{in}$$

$$f_n = \frac{0.71}{2 \pi} \sqrt{\frac{2.08 \times 10^6}{348}} = 8.7 \text{ Hz}$$

A resonant speed of 87 RPM would result from a six-bladed propeller. Fewer blades would bring the resonant speed undesirably closer to full power. The mean thrust at 87 RPM is $(87/130)^2 \times (300,000) = 134,000 \text{ lb}$. From Figure 4, the stiffness of the thrust bearing housing is

Ship Vibration Design Guide

found to be 15×10^6 lb/in; from Figure 5, assuming a six-shoe 40-in. thrust bearing, the element stiffness is estimated at 18.4×10^6 lb/in. Combining these stiffnesses in series, the overall thrust bearing stiffness, K_3 , is approximately 8.3×10^6 lb/in.

The foundation stiffness K_4 is estimated from Figure 6 to be 21×10^6 lb/in; however, natural frequencies will be found for a range of values of K_4 .

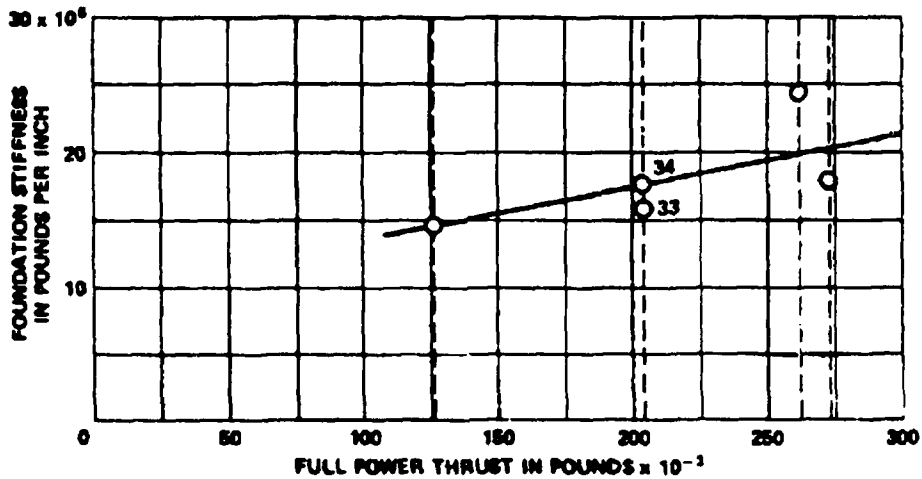

Figure 6

Foundation Stiffness versus Full Power Thrust

The mass-elastic diagram is now completely defined and is shown in Figure 21.

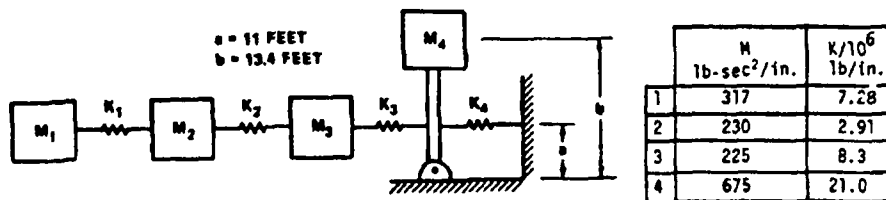

Figure 21a - System with Lever Effect Acting on Foundation Mass

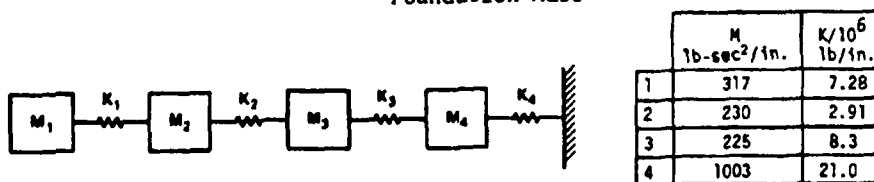

Figure 21b - Equivalent In-Line System, Foundation Mass Referred to Shaft Level

Figure 21

Mass-Elastic Representation of Example Problem

The next step is to calculate the first-mode natural frequencies as a function of foundation stiffness. The rationale is that if a small change in the predicted foundation stiffness causes a relatively large change in the corresponding natural frequency, then the designer should attempt to more closely estimate the foundation stiffness. Perhaps a procedure of structural analysis may be available to him or he may search the literature for experimental results on a similar ship. In any event, the designer should be aware of the relationship of frequency to foundation stiffness of the system under study.

Several methods are available for determining natural frequencies, many of which are programmed on digital computers. For simplicity, a Holzer analysis may be employed, as shown in Section 5.3.1. A discussion of the various computational methods will not be undertaken since it is assumed that the designer has such means at his disposal.

The natural frequencies of the mass-elastic system shown in Figure 21 are plotted in Figure 22 as a function of foundation stiffness. The results show the effect on the system with and without a lever. Since the lever has the effect of increasing the foundation mass when referred to shaft level, it is reasonable to expect a reduction in the frequencies of the first and second modes. The first-mode frequencies did not change significantly, but the second-mode frequencies were noticeably lowered due to the lever effect. This was because the foundation mass did not have a large amplitude relative to the propeller for the first mode as it did for the second. Incidentally, the lever effect could possibly be the reason why foundation stiffness values deduced from past trial measurements have been considerably higher than design estimates. The magnitude of the difference would be a direct function of the lever ratio b/a , which in our sample problem is not large enough to show any appreciable change in the first-mode frequency.

The preliminary frequency estimate of 8.7 Hz obtained by using the procedure in Figure 20 is considered close enough to the first-mode frequency of 8.8 Hz. From Figure 22 ($K_d = 21 \times 10^6$ lb/in.) shows that an adjustment to the thrust bearing stiffness K_b is not warranted. An iteration in determining the thrust bearing stiffness is recommended should the frequencies obtained by the two methods differ by more than 20 percent.

For a natural frequency of 8.8 Hz, the corresponding resonant shaft speeds for different numbers of blades, would be:

<u>Number of Blades</u>	<u>Resonant Shaft Speed RPM</u>	<u>Percent of Full Power</u>
4	132	101
5	105.6	81
6	88	68

Obviously, four blades would not be a prudent choice because of the close proximity of the resonant shaft speed to the full-power shaft speed of 130 RPM. The five-bladed resonant speed is considered sufficiently close to full power to discount a five-bladed propeller as a likely candidate. Therefore six blades is recommended.

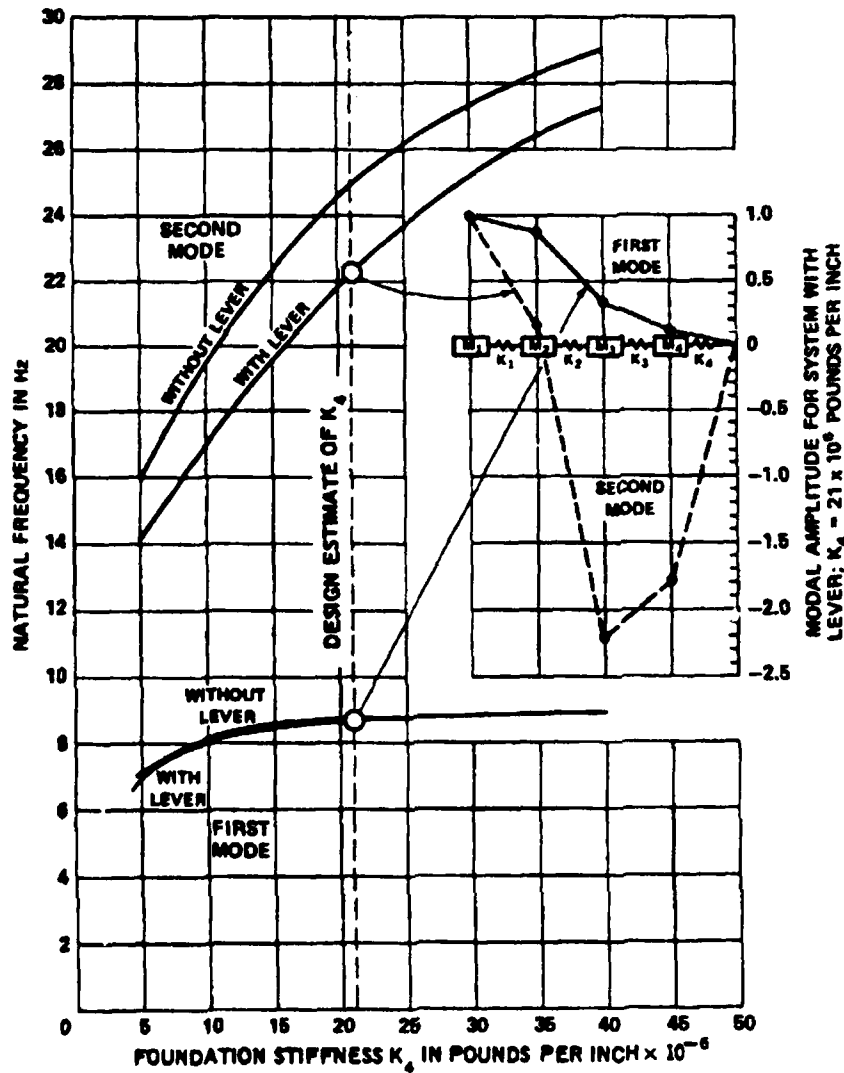

Figure 22

Relationship Between Natural Frequency, Foundation Stiffness and Lever Effect

5.3.2.2 Response Analysis

To obtain the longitudinal vibratory response of the propulsion system we will require the application of the vibratory exciting forces and system damping characteristics to the computer program for the developed model.

Based on the limited data available at the time of the initial study, Reference [5-17], the estimated longitudinal vibratory force, derived from similar ship types, was $\pm 0.9\%$ of the mean propulsive thrust, below 90% of full power RPM. Above 90 percent of full power, the vibratory force increased to ± 2.6 percent. Since these values are average (sinusoidal) input functions, similar to functions obtained from wake surveys, a factor of 2.9, obtained from test results on ships reported on in the referenced study, [5-17], is used to obtain the maximum repetitive value.

At 88 RPM, using a square function, the mean thrust would be:

$$\left(\frac{88}{130}\right)^2 \times 300,000 = 137,467 \text{ lbs}$$

$$\text{The alternating thrust} = \pm 0.009 \times 137,467 = \pm 1237 \text{ lbs}$$

$$\text{Peak value (MRV)} = 2.9 \times \pm 1237 = \pm 3587 \text{ lbs}$$

Damping, C_{eq} , provided by the propeller, is dependent on the developed area. In the sample calculation, a six-bladed propeller, 21 feet in diameter, with a developed area of 225 square feet, was used. The damping constant, C_{eq} of 4100 lb-sec/in, was obtained from Figure 14 of Reference [5-17], as developed by Rigby [5-20].

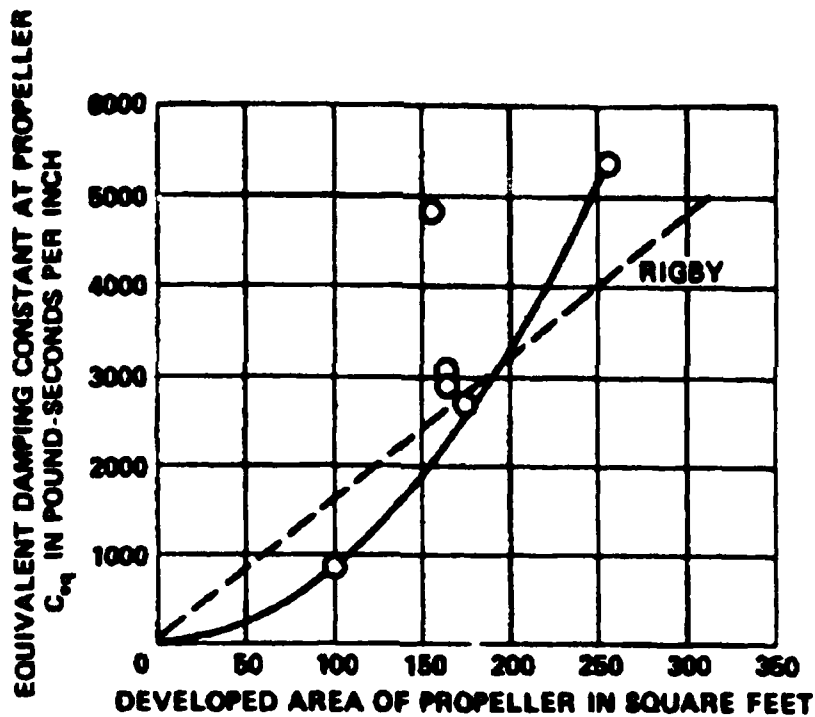

Figure 14

Equivalent Damping Constant at Propeller as a Function of Propeller Developed Area

Results of the digital computer analysis, using an alternating thrust of ± 3587 lbs. and a damping constant of 4100 lb-sec/in is shown on Figure 23, from Reference [5-17], to be approximately $\pm 28,000$ lbs. The magnification factor would be $28,000/3587 \approx 8$. Under maneuvering conditions, an increase in amplitude by a factor of 2.5, also derived from full-scale tests, results in an alternating thrust of $\pm 70,000$ lbs, well below the criteria given in MIL-STD-167, [5-19].

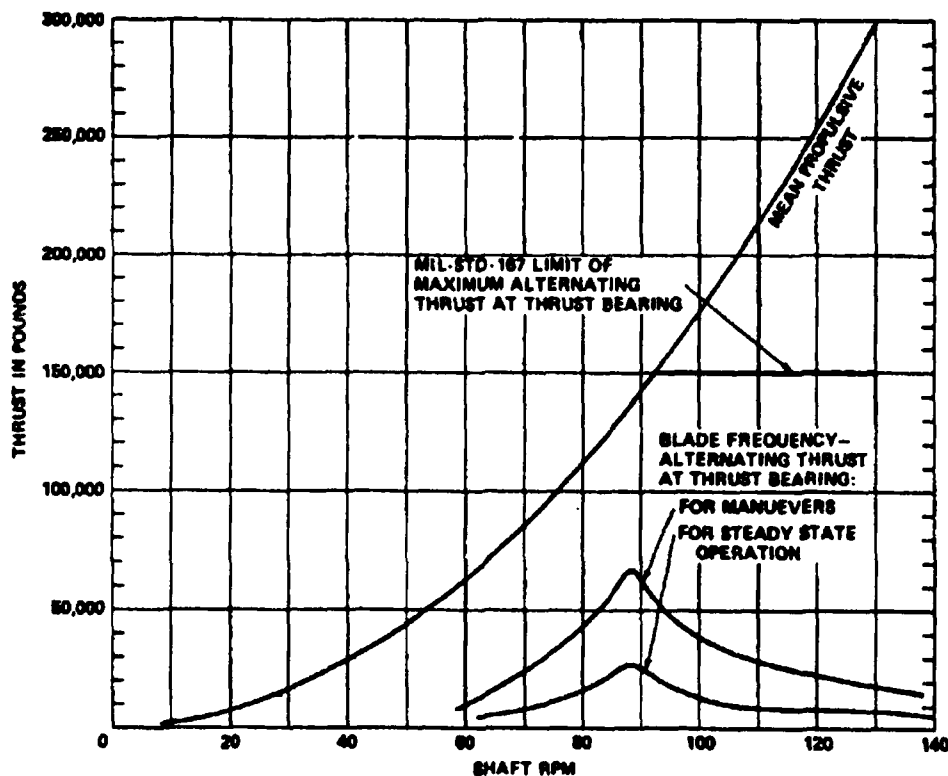

Figure 23

Calculated Blade Frequency-Alternating Thrust at Thrust Bearing for Six-Bladed Propeller and Comparison with MIL-STD-167A Criteria

Figure 24 shows that the machinery foundation, at shaft level, has a resonant vibratory displacement of ± 0.0018 in. The low- and high-pressure turbines with a b/a of 1.6 will have a displacement of about ± 0.0029 in., ± 0.0073 in. when applying the factor of 2.5 for maneuvering. This is still below the maximum value of ± 0.030 in. allowed in MIL-STD-167 [5-19].

5.3.2.3 Diesel Propulsion Drive Systems

Longitudinal vibration of medium and high-speed diesel driven propulsion systems, which employ reduction gears, can normally be treated in a manner similar to that of the geared-turbine drives treated in the previous sections. When possible, it is preferable to avoid having the fundamental longitudinal critical, excited by the propeller-blade frequency, above the operating speed range. If this cannot be accomplished, the fundamental critical should be kept in the low power range and the second frequency above the operating range. Care should be taken in the selection of the propeller characteristics to avoid strong second harmonics from exciting the higher modes of the system, which may be introduced in the shafting or in webbed frame of the bull gear. When controllable-pitch propellers are employed, the operating speed-range is generally limited, which would then provide greater latitude in the design, to avoid longitudinal vibration problems.

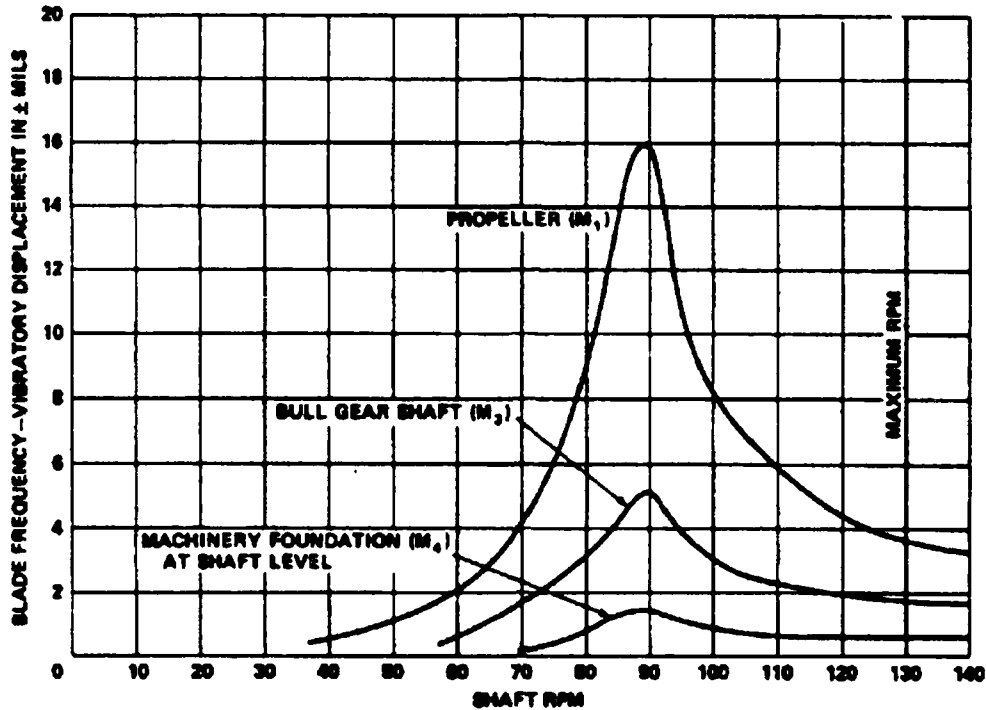

Figure 24

Calculated Longitudinal Vibratory Response of Example Propulsion System with a Six-Bladed Propeller

The potential vibration problems associated with geared diesel-drive systems, will however, require primary consideration be given to their torsional vibration characteristics. This approach would dictate the choice of the engine-gear couplings and clutches, which in most cases, reduce the impact of cross-coupling of the torsional and longitudinal vibration characteristics.

The range of possibilities of geared diesel-drive systems, subject to both longitudinal and torsional vibration problems, when excited by both propeller and engine harmonics, are practically limitless. For guidance, it is recommended that proposed engine-gear drive systems be solicited from potential manufacturers with complete torsional vibration analyses provided by the engine builder, including the initial propeller and shafting arrangement, for review and check by the designer performing the preliminary vibration analysis for the shipbuilder. Based on the acceptability of the proposed arrangement, modifications to the propeller-shafting system can be introduced to avoid longitudinal vibration problems. The procedures, previously used for geared-turbine drives, can be effectively used for this purpose.

In the application of large, slow-speed, direct-drive diesels, the combination of longitudinal and torsional vibration of the system, in which propeller and engine exciting forces are involved, can present difficult problems in determining how well the drive system will function. When we include engine unbalanced forces and moments, previously discussed in Section 5.1.3,

propeller characteristics discussed in Chapter Three, and the hull vibration characteristics covered by Chapter Four, we can readily appreciate the total complexity of the shipboard vibration problem. To minimize the risk, it is necessary to treat the problem early, in the preliminary design phase. To omit the preliminary design analyses would be equivalent to playing "Russian Roulette."

In this chapter, dealing with Propulsion System Vibration, we have treated the subject in five sections, included as five individual areas of concern. In most cases these phenomena seriously impact each other. Potentially the most serious impact could be the interaction between the torsional and longitudinal vibration characteristics of the engine-drive system. As in the geared-diesel drive system, torsional vibration in the direct-drive diesel application would be considered potentially more dangerous. In this regard, we would again recommend the potential engine builder provide a complete torsional vibration analysis of the engine and the proposed propeller-shafting system, for evaluation by the preliminary design engineers. Compatibility with the longitudinal vibration characteristics of the total propulsion system and the hull-girder response is required. The interaction or coupling of torsional and longitudinal vibration, through the oscillating motion of the propeller, should be investigated.

5.3.3 General Comments

The original issue of MIL-STD-167, as published in 1954, prohibited the presence of the fundamental longitudinal critical from occurring within the normal operating speed range of the ship. This appeared to be a logical conclusion following the serious difficulties encountered during and immediately following WW II. This conclusion was based on the limited experience available at that time, in which longitudinal criticals were noted in the full-power range and compromises had to be struck between acceptable hull vibration and longitudinal vibration of the main propulsion systems, on multiple shaft ships. However, this requirement was, of necessity, waived in a number of cases. Thus, in 1969, based on limited test data, a revision of MIL-STD-167 was issued, which permitted longitudinal criticals to fall within the operating speed range, but with restrictions on the response at these criticals. At this time, approximately 20 years later, the same criteria exists, and the best available study on the subject was that published by NSRDC, [5-17], 1970.

As is shown in this preliminary design analysis, we can now predict, but with limited confidence, the fundamental longitudinal vibratory response of the main propulsion system. However, we are still a long way from being able to satisfy a number of inconsistencies between the analysis and the requirements for a reliable machinery system, particularly when reduction gears are employed. A few important points require specific attention, including:

- The development of more appropriate service factors for all operations.
- The development of more suitable reduction gear alternating load criteria.
- The development of longitudinal stiffness data for bull-gear web frames.
- A program for the development of more suitable input and damping functions.
- An updated version of MIL-STD-167, Type IV, Longitudinal Vibration.

Based on more recent experience, it is considered most important that the detailed longitudinal vibration analysis be carried out as early as possible, during the detail design phase. This should preferably be provided by the engine builder, with designer support, to demonstrate probable compliance with specifications, with increased reliability.

5.4 Torsional Vibration of Propulsion Systems

Torsional vibration in propulsion systems was briefly described in Section 1.7.4 as the alternating torque produced by a ship's propeller and/or the engine harmonics in a diesel drive system. The mass-elastic system involved consists of the rotating elements in the total propulsion system and primarily effects the integrity of the shafting and the reduction gears. Ordinarily, torsional resonances within the shafting system does not produce serious problems in the ship's structure but can produce damaging effects in reduction gear mesh, especially in adverse sea conditions. In diesel engine drive systems of all types, engine harmonics, produced in the engine, can generate destructive forces within the engine and the drive system at resonant conditions, as well as adverse structural response through torque reactions. In some cases, coupling with longitudinal vibration problems are generated through the oscillating action of the ship's propeller.

Historically, the torsional vibration problem became recognized early in the development of ship propulsion systems, through major casualties experienced in steam engine crankshafts and propeller shafts. Although the powers were low, the resonance effects, coupled with high alternating torques and stress magnifiers, could produce catastrophic failures, such as loss of the propeller and broken crankshafts. The rapid development of the diesel engine, as applied to ship propulsion systems, generator and dredge-pump drives, accelerated research in this area. At the start of WW II, torsional vibration problems were a major concern, both in engine development and application in the submarine and surface ship construction program. This problem directly led to the establishment of the torsional vibration committee of the S.A.E., a major effort of research on diesel engine development sponsored by the U.S. Navy and the development of the torsional vibration criteria given in MIL-STD-167, [5-21]. Drafted in 1949, this criteria was originally published in 1954 and has not been modified since.

In all commercial and Naval ships, the evaluation of the torsional vibration characteristics of the propulsion system is required. In the preliminary design analysis of a proposed propulsion system, relatively simple analyses will suffice for most cases. Usually, the fundamental critical will fall below the normal operating speed range and in a geared drive may produce a "rattle" in the gears, as the critical is passed through. This critical should be avoided in the operating speed range since it could result in gear damage. A detailed analysis of the torsional vibration characteristics of the final design must be submitted for Naval or Classification Society approval. This analysis is generally provided by the engine builder and should be specified in the purchase contract.

In direct-drive diesel arrangements, it is necessary to consider excitations by both the propeller and engine harmonics. Although the propulsion shafting can be treated in a simplified manner to establish preliminary shafting requirements relative to torsional vibration, in a manner similar to that used for geared drive systems, the detailed analysis, generally provided by the engine builder, should be carried out as soon as possible to insure compliance with specifications and/or Classification Society rules.

5.4.1 Torsional Vibration Analysis of the LNG Carrier Propulsion System

Simplified torsional vibration analyses, carried out in the preliminary design studies, for the Project and Conventional Hull designs for the LNG Carrier, are shown as an example. Similar analyses for propeller-excited torsional vibration, are applicable for diesel drive systems. The detailed torsional vibrational analyses for the total systems, as required by specification acceptance, is considered beyond the preliminary design requirements and are not shown here. For reference, "Mechanical Vibrations," by DenHartog, [5-22], "Practical Solution to Torsional Vibration Problems," by Ker Wilson, [5-23], and "A Handbook on Torsional Vibration," [5-24], are recommended.

Only the first mode will be investigated since the turbine and reduction gear inertia and stiffness values are presently known. It should also be mentioned that these values are usually selected by the machinery vendor to cancel out the 2nd mode (i.e. to "tune" the two turbine branches to the same frequency resulting in a node at the bull gear) and to raise the 3rd mode above the maximum blade frequency excitation. Therefore, the torsional model is a simple two-mass system:

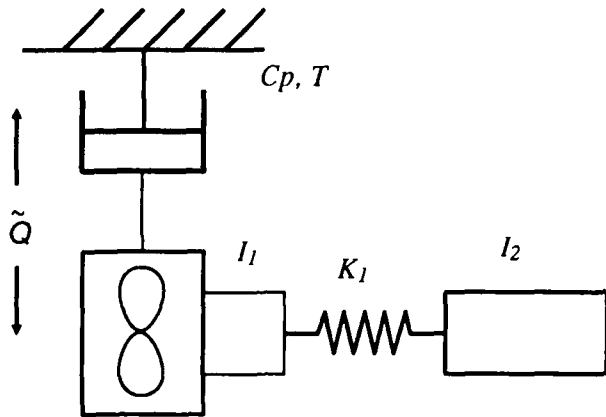

$$C_{p,T} = \text{in-lb-sec} / \text{rad}$$

$$\tilde{Q} = \pm \text{in-lb}$$

$$I = \text{lb-in-sec}^2$$

$$K = \text{in-lb} / \text{rad}$$

- $I_1 =$ Propeller Inertia (including entrained water) + $\frac{1}{2}$ Shafting Inertia
- $I_2 =$ $\frac{1}{2}$ Shafting Inertia + Inertia of All Rotating Gear and Turbine elements
- $K_1 =$ Overall Stiffness of Shafting
- $\tilde{Q} =$ Alternating Propeller Torque
- $C_{p,T} =$ Equivilant Propeller Damping Constant

5.4.1.1 Frequency Analysis of Project Hull

The propeller (and entrained water) mass moment of inertia, based on preliminary Hydronautics estimates of 7 February 1971 is:

$$I_p = \frac{522 \times 10^6 \times 1.25}{386} = 1.69 \times 10^6 \text{ lb-in-sec}^2$$

The mass moment of inertia of the shaft is:

$$I_s = \frac{\pi D^4 \rho L}{32g} \text{ lb-in-sec}^2$$

$$I_s = \frac{\pi \times 0.284}{32 \times 386} \times [36^4 \times 678 + 32.25^4 \times 684] = 0.136 \times 10^6 \text{ lb-in-sec}^2$$

where:

- D = Shaft Diameter, inches
- ρ = Density of Material = .284 lb / in³
- L = Length of Shaft in inches
- g = 386 in / sec²

The inertia of the rotating machinery elements (I_M) was estimated from those of a similar system of equal torque rating. The inertia values are all referred to the propeller speed.

	<u>lb-in-sec²</u>
Low Speed Gear and Shaft	600,000
Low Speed Pinions (4)	52,000
Low Pressure High Speed Gears (2)	1,125,000
High Pressure High Speed Gears (2)	1,290,000
Low Pressure High Speed Pinion and Coupling	276,000
High Pressure High Speed Pinion and Coupling	330,000
Low Pressure Turbine Rotor	21,400,000
High Pressure Turbine Rotor	<u>2,500,000</u>
Total:	27,573,000

$$I_1 = I_p + \frac{I_s}{2} = 1.69 \times 10^6 + 0.068 \times 10^6 = 1.758 \times 10^6 \text{ lb-in-sec}^2$$

$$I_2 = I_M + \frac{I_s}{2} = 27.573 \times 10^6 + 0.068 \times 10^6 = 27.641 \times 10^6 \text{ lb-in-sec}^2$$

The torsional stiffness of the tailshaft (see Figure 5-9) is:

$$K_{TS} = \frac{\pi G D^4}{32L}$$

where:

$$G = 12 \times 10^6 \text{ lb / in}^2$$

$$K_{TS} = \frac{\pi (12 \times 10^6) 36^4}{32 \times 678} = 2,919 \times 10^6 \text{ in-lb / rad}$$

Ship Vibration Design Guide

The stiffness of the stern tube, line and thrust shafts is:

$$K_{LS} = \frac{\pi (12 \times 10^6) 32.25^4}{32 \times 684} = 1,860 \times 10^6 \text{ in-lb / rad}$$

The combined stiffness of the shafting is:

$$K_S = \frac{1}{\frac{1}{K_{TS}} + \frac{1}{K_{LS}}} = \frac{1 \times 10^6}{\frac{1}{2919} + \frac{1}{1860}} = 1136 \times 10^6 \text{ in-lb / rad}$$

Frequency is:

$$\frac{1}{2\pi} \sqrt{\frac{1136 \times 10^6 (1.758 + 27.641) \times 10^6}{1.758 \times 27.641 \times 10^{12}}} = \frac{1}{2\pi} \sqrt{687} = 4.17 \text{ Hz}$$

Fifth order critical:

$$4.17 \times \frac{60}{5} = 50 \text{ RPM}$$

5.4.1.2 Frequency Analysis of Conventional Hull

The propeller (and entrained water) mass moment of inertia (I_p) is assumed equal to that obtained for the Project Hull = $1.69 \times 10^6 \text{ lb-in-sec}^2$. The mass moment of inertia of the propeller shaft is:

$$I_S = \frac{\pi D^4 \rho L}{32g} \text{ lb-in-sec}^2 = 72.7 \times 10^{-6} D^4 L$$

$$I_{TS} = 72.7 \times 10^{-6} (1.68 \times 10^6) (438) = 53,500 \text{ lb-in-sec}^2$$

$$I_{LS} = 72.7 \times 10^{-6} (1.08 \times 10^6) (492) = \underline{38,700} \text{ lb-in-sec}^2$$

$$I_S = 92,200 \text{ lb-in-sec}^{21}$$

The inertia of the rotating machinery elements (I_M) will be assumed as equal to that previously estimated = $27,573 \times 10^6 \text{ in-lb-sec}^2$.

$$I_1 = I_P + \frac{I_S}{2} = (1.69 + 0.046) \times 10^6 \times 10^6 = 1.736 \times 10^6 \text{ lb-in-sec}^2$$

$$I_2 = I_M + \frac{I_S}{2} = (27.573 + 0.046) \times 10^6 = 27.619 \times 10^6 \text{ lb-in-sec}^2$$

The torsional stiffness of the propeller shaft (see Figure 5-16) is:

$$K_S = \frac{\pi G D^4}{32L} = \frac{1.178 \times 10^6 \times D^4}{L}$$

$$K_{TS} = \frac{1.178 \times 10^6 \times 1.68 \times 10^6}{438} = 4,530 \times 10^6 \text{ in-lb / rad}$$

$$K_{LS} = \frac{1.178 \times 10^6 \times 1.08 \times 10^6}{492} = 2,580 \times 10^6 \text{ in-lb / rad}$$

$$K_S = \frac{1}{\frac{1}{K_{TS}} + \frac{1}{K_{LS}}} = \frac{1 \times 10^6}{\frac{1}{4530} + \frac{1}{2580}} = 1,640 \times 10^6 \text{ in-lb / rad}$$

Frequency is:

$$\frac{1}{2\pi} \sqrt{\frac{1640 \times 10^6 (1.736 + 27.619) \times 10^6}{1.736 \times 27.619 \times 10^{12}}} = \frac{1}{2\pi} \sqrt{1,000} = 5.03 \text{ Hz}$$

Fifth order critical:

$$5.03 \times \frac{60}{5} = 60 \text{ RPM}$$

5.4.1.3 Response Calculations

The alternating propeller torques used in the response calculations were those obtained from the analysis of the NSMB wake data and the NKF estimated propeller characteristics. These torques, given in Table 2, were 56,660 ft-lbs and 88,780 ft-lbs for the Project Hull and Conventional Hull, respectively. From SHP data, the estimated service SHP^m was 41,600 at 20 knots for the Project Hull and 34,400 at 19 knots for the Conventional Hull. This would correspond to 41,000 and 34,000 SHP in terms of British units, for the Project and Conventional Hulls, respectively. Estimated torques (\bar{Q}) at the nominal service condition would then be:

$$\bar{Q} = 5250 \times \frac{41,000}{100} = 2,150,000 \text{ ft-lbs for Project Hull}$$

$$\bar{Q} = 5250 \times \frac{34,000}{100} = 1,785,000 \text{ ft-lbs for Conventional Hull}$$

These values check well with the values of \bar{Q} obtained by the propeller force calculations given in Table 5-2, and which were obtained with the estimated propeller characteristics used in the study. The estimated ratio of alternating torque to the driving torque, as given in Table 5-2, was approximately 2.75% and 5% for the Project Hull and Conventional Hull, respectively and appear to represent reasonable values.

For considering the allowable vibratory torques, the full power rating of the machinery, which is assumed to be the same for either hull, was taken as 45,000 SHP at 100 RPM. This value is used since the service condition represents an average condition and at times is assumed that the maximum condition would occur. Therefore, the allowable alternating torque, from the specifications, is taken as $\pm 10\%$ of maximum and would equal approximately:

$$\tilde{Q}_A = \frac{.10 \times 63,000 \times 45,000}{100} = \pm 2.835 \times 10^6 \text{ in-lbs}$$

Ship Vibration Design Guide

The torsional damping used in the response analysis was limited to propeller damping, as is customary for first mode analyses, and was based on propeller damping given in reference [5-22]. The propeller damping C_p, T , is estimated by the relationship:

$$C_p, T = 4 \frac{Q}{\Omega}$$

where:

$$\Omega = \frac{\omega}{B}$$

$$\omega = 4.17 \times 2\pi = 25.2 \text{ (Project Hull)}$$

$$\omega = 5.03 \times 2\pi = 31.6 \text{ (Conventional Hull)}$$

$$B = \text{Number of Blades} = 5$$

$$Q = \text{Mean Torque}$$

For Project Hull:

$$C_p, \bar{T} = 4 \times 28.35 \times 10^6 \times \left(\frac{50}{100} \right)^2 \times \frac{5}{25.2} = 5.62 \times 10^6 \text{ in-lb-sec / rad}$$

For Conventional Hull:

$$C_p, \bar{T} = 4 \times 28.35 \times 10^6 \times \left(\frac{60}{100} \right)^2 \times \frac{5}{31.6} = 6.45 \times 10^6 \text{ in-lb-sec / rad}$$

Results of the estimated alternating torque at resonance, for both hulls, obtained by computer analysis, is shown in Figure 5-19. For reference, the specification allowance is also shown.

5.4.2 Direct Diesel Drive Systems

The two-mass system used for the preliminary torsional vibration analysis of the turbine driven LNG carrier can also be used for direct diesel drive systems, provided that the torsional stiffness of the propulsion shafting is less than one-fourth the stiffness of the full length of the engine crankshaft, as noted in Reference [5-9]. This reference also provides convenient procedures for estimating the vibratory torque in the shafting system when using propeller damping as defined by Den Hartog, [5-22], and used in the LNG analysis. For the alternating propeller input torques, for single-screw ships, estimates may be taken from similar ship types, such as given in Table 5-2. For the more detailed analysis, to be carried out during the design phase, References [5-23] and [5-24] would be most helpful. It is presumed however, that the detailed analysis would be provided by the engine builder who would be in a better position to provide the necessary harmonic forces and the total system damping characteristics, based on past experience.

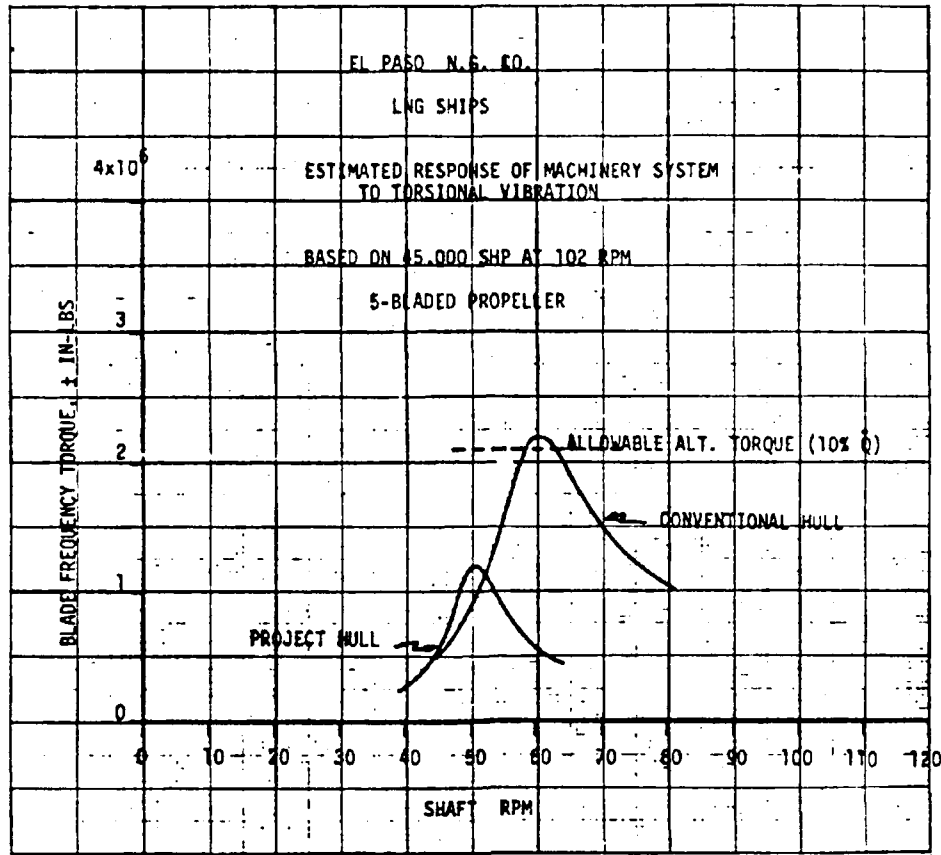

Figure 5-19

Estimated Response of Machinery System to Torsional Vibration

5.5 Lateral Vibration of Propulsion Shafting

The numerous fractures of propeller shafts, which occurred on a number of single-screw ships built during WW II, was discussed in Section 5-2, prompted the study of the lateral vibrations of shaft-disc systems, at the David Taylor Research Center, in 1950. The purpose of the study as defined by Jasper in his 1954 report, "A Design Approach to the Problem of Critical Whirling Speeds of Shaft-Disc Systems," [5-25], was:

- (a) To familiarize the designer with the problem of whirling vibration so that he will give it proper consideration in the design of shafting and shaft supports.
- (b) To provide the designer with an approximate method for computing the fundamental critical whirling speed of the tailshaft system.
- (c) To indicate the more exact but more complex methods that were being studied for possible application to the whirling problem.

Ship Vibration Design Guide

For background information and reference, it was also in 1950 that Panagopulos presented "Design Stage Calculations of Torsional, Axial and Lateral Vibration of Marine Shafting," [5-26] and Hesse presented "Critical Speeds of Overhung Shafts," [5-27]. In 1952, Jasper and Rupp presented the paper "An Experimental and Theoretical Investigation of Propeller Shaft Failures," [5-28], which provided background information for the 1954 Jasper report, [5-25].

The problem of tailshaft failures was finally attributed to the high bending stresses resulting from the steady, eccentric thrust, which produces a high alternating stress at shaft rotational frequency, in combination with corrosion fatigue, originating at the propeller-shaft keyway, [5-10], [5-11]. As a result of these studies however, it was recognized that, in addition to designing the tailshaft to accommodate the high bending stresses, that an understanding of the whirling characteristics of the propeller-shaft systems was necessary to avoid serious system resonances.

First order whirling of the propulsion shafting (whipping) is caused by unbalance and can result in shaft failure if the rotational frequency coincides with the lateral natural frequency of the propeller-shaft system in the absence of sufficient damping forces. Of lesser importance is the whirl excited by externally applied forces of frequency n times the shaft RPM (n^{th} order whirl), where n is the number of propeller blades or their harmonics. The whirling motion may occur in the direction of, or in the opposite direction to the direction of rotation of the shaft. At a fixed point on the shaft, this will produce $(n-1)$ cycles of bending stress for forward whirl and $(n+1)$ cycles of bending stress for counter whirl. Thus for a four-bladed propeller, stress components of $n-1$ and $n+1$ may occur. An example of this phenomena is shown in Figure 5-20, taken from Reference [5-10]. The reported data shows the 3rd and 5th order stresses produced by the alternating thrust of the four-bladed propeller and the 7th and 9th order produced by the second harmonic of the alternating thrust of the four-bladed propeller. The major 1st order stress amplitude results from a single revolution of the shaft and the steady eccentric thrust generated by the propeller. It is this high bending stress, generated by the thrust eccentricity in combination with the corrosion fatigue properties of the shafting, which was determined to be the cause of the shaft failures encountered. Relative to the eccentric thrust loading, the blade-frequency stress values are small, in this case.

The necessity of avoiding the fundamental lateral frequency of the propeller-shaft system, which is the most critical section of the propulsion system, is obvious since operation at that critical is destructive. Of the alternate design analysis procedures, that of Panagopulos provides an estimate of the fundamental system frequency, while both the Jasper and Hesse formulas include the gyroscopic effects of the propeller and result in higher frequencies, which may be referred to as whirling frequencies. A comparison of the results obtained by the three methods is shown in the sample preliminary design study shown in Appendix A.

Of the three methods, the Panagopulos formula more closely represents the fundamental propeller-shaft system frequency, primarily due to the greater influence placed on the shaft mass, which is significant. Therefore, since the fundamental lateral propeller-shaft frequency, when excited by unbalance can be destructive, it is considered conservative to use this procedure, which results in the lowest frequency. This method is also used by the Navy [5-9].

Much has been said about the necessity of avoiding whirling-frequency resonance, when excited by blade-frequency or the second harmonic of blade-frequency. Although these frequencies do exist in fact, as noted in Figure 5-20, and do occur within the operating range, the existing forces are generally not sufficiently severe as to be of serious concern, unless coupled with other adverse conditions, such as the unloading of the forward bearing. This view is also noted by Bureau Veritas, Reference [5-5] and Long, [5-29].

For preliminary design purposes, the Panagopoulos method of estimating the fundamental lateral frequency of the propeller-shaft natural frequency is recommended and the sample calculation is shown for the LNG carrier.

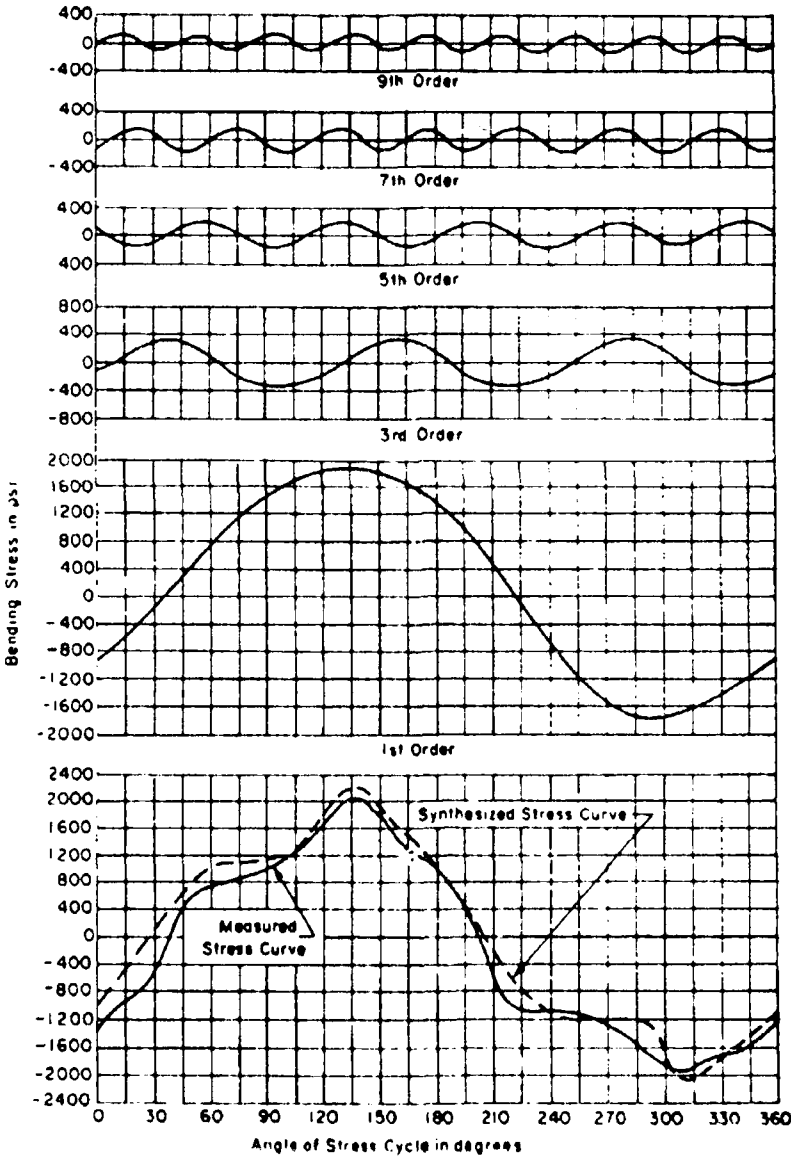

Figure 5-20

Harmonic Analysis, Heavy Load - Calm Sea

5.5.1 Lateral Vibration (Whirling) Frequency of the LNG Carrier

The Panagopolos [5-25] procedure for estimating the critical (fundamental) natural frequency of lateral vibration of the shafting system is the most conservative and is used on the LNG Carrier's initial arrangement, Figure 5-9, for demonstration purposes.

$$f = \frac{30}{\pi} \sqrt{\frac{iE}{I_x \left(b + \frac{l}{3} \right) + W_p \frac{b^2}{g} \left(\frac{b}{2} + \frac{l}{3} \right) + \mu \left(\frac{b^4}{8} + \frac{lb^3}{9} + \frac{7l^4}{360} \right)}$$

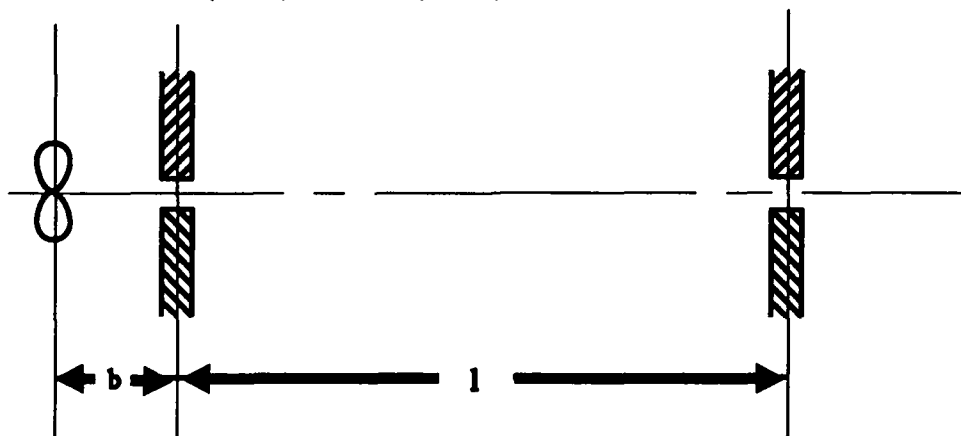

where:

- f = Cycles per Minute
- i = Shaft Moment of Inertia About the Diameter = $D^4/64 = 82,448 \text{ in}^4$
- I_p = Mass Moment of Inertia of Propeller About its Axis, lb-in-sec^2
- I_x = Mass Moment of Inertia of Propeller About its Diameter, plus plus 60% for Entrained Water = $\frac{1}{2} I_p \times 1.6, \text{ lb-in-sec}^2$
- W_p = Weight of Propeller, including Shaft Stub, Nut and Hub Cap 25% for Entrained Water, lbs (air)
- μ = Shaft Mass per Inch = $W/g \text{ lb-sec}^2 / \text{in}^2$
- E = Young's Modulus = $30 \times 10^6 \text{ lbs} / \text{in}^2$
- b = Distance of Propeller Centerline to Bearing Centerline = 141 in
- l = Bearing Centerline Distance = 540" of 36" diameter + 48" of 32.25 diameter
 Equivilant l for 36" diameter is $48 \times \frac{36^4}{32.25^4} = 72" + 540"$
 = 612" of 36" diameter
- I_p = $\frac{522 \times 10^6}{386} = 1.35 \times 10^6 \text{ lb-in-sec}^2$
- I_x = $\frac{1}{2} \times 1.35 \times 1.6 \times 10^6 = 1.08 \times 10^6 \text{ lb-in-sec}^2$

Propulsion System Vibration

$$W_p = 122,650 \text{ (propeller)} + 27,260 \text{ (stub shaft, nut, etc.)} = 149,910 \text{ lbs}$$

$$W_p/g = 149,910 \times 1.25/386 = 485 \text{ lb-sec}^2 / \text{in}^2$$

$$\mu = \frac{D^2}{4} \times \frac{0.284}{386} = 0.749 \text{ lb-sec}^2 / \text{in}^2$$

$$f = \frac{30}{\pi} \sqrt{\frac{82,448 \times 30 \times 10^6}{1.08 \times 10^6(141 + 204) + 485 \times 19,881 \times 274.5 + 0.749(49.407 + 190.62 + 2727.73) \times 10^6}}$$

$$f = 9.55 \sqrt{\frac{2,473,440 \times 10^6}{5,242 \times 10^6}} = 207 \text{ RPM}$$

This is well above the criteria minimum of 115% of maximum of 102 RPM

Note: In the particular case of the LNG Carrier, many modifications to the shafting system were introduced during the program development. However, with simple, readily checked analyses, such as this one, for lateral shaft vibration it is convenient for the quick identification of the effects of proposed modifications.

During the detailed design, more complete FEM analyses were carried out on the complete propulsion system. This should also be done in all ship detail design studies.

5.6 General Comment

Better control of the effective point of support of the aft bearing can be realized by the use of self-aligning bearings, which permit heavier loading, shorter bearings and self adjustment. This approach is then one of the best reasons for the use of the oil lubricated bearing, with reliable seals.

During detail design studies, in addition to the evaluation of lateral frequencies, bearing spacings and alignment calculations should be carried out and the studies should be documented for future use, as may be required.

Appendix 5-A is a sample preliminary machinery vibration analysis of the T-AO 187 propulsion system conducted for Levingston Marine Corporation by NKF Engineering on June 4, 1982.

Specific data on the unbalanced forces and moments generated by M.A.N. and Sulzer two-cycle engines are included as Appendix 5-B for information purposes. This data is extracted from MAN/B&W Project Guide, 1986 and Sulzer Technical Data for Marine Diesel Engines, 1988.

REFERENCES

- 5-1 MIL-STD-167-1 (Ships), "Mechanical Vibration of Shipboard Equipment," Type II, Internally Excited Vibration. 1 May, 1974.
- 5-2 Marine Engineering, Published by SNAME, 1971.
- 5-3 "Guide to Propulsion Reduction Gear Alignment and Installation," Technical and Research Bulletin No. 3-43, SNAME, September, 1987.
- 5-4 Payer, H.G., and Asmussen, I., "Vibration Response on Propulsion- Efficient Container Vessels," SNAME Trans., Vol. 93, 1985.
- 5-5 "Building and Operation of Vibration Free Propulsion Plants and Ships," Bureau Veritas Publication NR 207 SMS E, November, 1987.
- 5-6 "Prevention of Harmful Vibration in Ships, Det Norske Veritas Guidelines," July, 1983.
- 5-7 ISO 4867, "Code for the Measurement and Reporting of Shipboard Vibration Data," December 1984.
- 5-8 "Rules for Building and Classing Steel Vessels," A.B.S., 1986.
- 5-9 "Propulsion Shafting," Design Data Sheet, DDS 4301, U.S. Navy Department, 1960.
- 5-10 Noonan, E.F., "Propeller Shaft Bending Stresses on the S.S. Esso Jamestown," A.S.N.E. Journal, August, 1961.
- 5-11 Nickerson, Archer M., Jr., "Summary Report of the Investigation of Tailshaft Failures," SNAME T & R Report R-2, January, 1966.
- 5-12 Noonan, E.F., "Vibration Considerations on Project and Conventional Hulls for 125,000 CM LNG Ships," NKF Project 7107, May, 1971.
- 5-13 Noonan, E.F., "Propeller Shaft Bending Stresses on the USNS Lt. James E. Robinson," Noonan, Knopfle and Feldman Report, September, 1955.
- 5-14 Noonan, E.F., "Preliminary Hull and Machinery Vibration Analyses for DD-963 Class Destroyer Design," NKF Report R-7105-4, to Litton Systems, Inc., February, 1971.
- 5-15 Noonan, E.F., "Design Considerations for Shipboard Vibration," SNAME, Marine Technology, January, 1971.
- 5-16 Hinterthan, W.B., "Bossing Design for the Wing Screws of the New Design Polar Icebreaker," for USCG, Washington, D.C., NKF Project 6819, August, 1968.

Propulsion System Vibration

- 5-17 Zaloumis, A. and Antonides, G.P., "Recent Developments in Longitudinal Vibration of Surface Ship Propulsion Systems," NSRDC Report 3358, September, 1970.
- 5-18 "Longitudinal Stiffness of Main Thrust Bearing Foundation," SNAME T & R Report R-15, 1972.
- 5-19 Military Standard, "Mechanical Vibration of Shipboard Equipment," Type IV, Longitudinal Vibration, MIL-STD-167-2 (Ships), 1 May, 1974.
- 5-20 Rigby, C.P., "Longitudinal Vibration of Marine Propulsion Shafting Systems," Institute of Marine Engineers, February, 1948.
- 5-21 Military Standard, "Mechanical Vibration of Shipboard Equipment," Type III, Torsional Vibration, MIL-STD-167-2 (Ships), 1 May, 1974.
- 5-22 Den Hartog, J.P., "Mechanical Vibrations," McGraw-Hill Book Company, New York.
- 5-23 Wilson, W. Ker., "Practical Solutions to Torsional Vibration Problems," Chapman and Hall, Ltd., London, 1963. (Two Volumes).
- 5-24 B.I.C.E.R.A., "A Handbook on Torsional Vibration," Cambridge University Press, 1958.
- 5-25 Jasper, N.H., "A Design Approach to the Problem of Critical Whirling Speeds of Shaft-Disc Systems," DTMB Report 890, December, 1954.
- 5-26 Panagopulos, E.P., "Design Stage Calculations of Torsional, Axial and Lateral Vibration of Marine Shafting," SNAME Trans. Vol. 58, 1950.
- 5-27 Hesse, H.C., "Critical Speeds of Overhung Shafts," Product Engineering, December, 1950.
- 5-28 Jasper, N. H. and Rupp, L.A., "An Experimental and Theoretical Investigation of Propeller Shaft Failures," SNAME Trans. Vol. 60, 1952.
- 5-29 Long, C.L., "Propellers, Shafting and Shafting System Vibration Analysis," Chapter XI, Marine Engineering, SNAME, 1971.

APPENDIX 5-A

Example Problem - Preliminary Vibration Analysis of Propulsion System*

The T-AO 187 is a U.S. Navy tanker now in the preliminary design stage. Livingston Marine Corporation is one of several companies viewing the preliminary design and has subcontracted NKF Engineering Associates, Inc. to assist. This report is in response to Paragraph 4.4.2.6 of the T-AO 187 Baseline Review:

Paragraph 4.4.2.6

A preliminary design evaluation of the proposed propulsion drive system will be carried out to determine its adequacy to meet the ship characteristics and design objectives within the constraints imposed by twin-shaft diesel drive systems. This study will include shaft strength calculation, torsional, lateral and longitudinal vibration analyses, and evaluation of proposed propeller characteristics. Specified comments and recommendations will be provided to permit the development of the detailed design of Phase II. Specific attention will be given to the interaction between propulsion systems components and the ship structure such as general shaft arrangements, bearing locations, foundation stiffness, volume and area requirements, and service requirements.

This preliminary analysis is based on limited data, particularly regarding the engine, power takeoff, clutches and couplings. Many assumptions were made and, where practical, the effect of varying some parameters was studied.

The propeller forces assumed for calculating longitudinal and torsional system responses are based on a companion study by NKF reported in Reference [1].

PURPOSE and SCOPE

The purpose of a preliminary vibration analysis is to determine the nature of any vibration problems likely to affect the design of the ship. In many cases the preliminary analysis indicates a certain type of vibration will not occur no matter what the detailed design. In other cases, it indicates that the designer does not have as much latitude and must be careful in working out details. In some cases it even shows that a basic design is unworkable. It is usually based on many assumptions and should not be used to finalize major decisions concerning the propulsion system configuration without confirming the conclusions with a detailed analysis. Such detailed analysis would be carried out under Phase II for the T-AO 187.

* from "Preliminary Vibration Analysis of Propulsion System," NKF Report No. 8213-001/2, June 1982.

Ship Vibration Design Guide

The scope of this preliminary analysis includes:

- Determining the sizes of the shafting in accordance with ABS rules [2] and the proposed bearing arrangements.
- Evaluating the shaft with respect to shaft strength, based on DDS 4301 [3].
- Calculating the longitudinal criticals for four cases: four- and five-bladed propellers; 80 and 90 RPM rated speeds.
- Estimating the alternating thrust in the thrust bearing and bull gear amplitude.
- Calculating the torsional natural frequencies for the cases cited above.
- Determining the alternating torsional stresses in the shaft.
- Calculating the shaft's lateral critical speed.
- Providing comments and recommendations for use in the detailed design.

SHIP CHARACTERISTICS

The T-AO 187 will have a twin-screw propulsion system with diesel engines and reduction gears. A power takeoff generator will be driven from the bull gear. This analysis was performed for both four- and five-bladed propellers and for rated shaft speeds of 80 and 90 RPM. The ship characteristics used for this study are given below.

Length Overall (<i>LOA</i>)	667 ft
Length Between Perpendiculars (<i>LBP</i>)	633 ft
Beam Molded (<i>B</i>)	93 ft 6 in
Depth (<i>D</i>)	50 ft
Draft (Maximum) (<i>d</i>)	35 ft
Draft-Scantling Molded (Type B) Approx.	37 ft 10 in
Displacement (Δ)	40,000 Long Tons
Length-Beam Ratio (<i>L/B</i>)	6.77
Beam-Draft Ratio (<i>B/d</i>)	2.67
Block Coefficient (C_B)	0.662
Prismatic Coefficient (C_P)	0.683
Midship Section Coefficient (C_M)	0.970
Midship Area Moment of Inertia (I_V) (Levingston) (4/19)	1,767,385 in ² ft ²
Wetted Surface	76,066 sq ft
Number of Shafts	2

SHP/Shaft*	16,865
Engine RPM*	430
Propeller Diameter (D_p) (CRP)	24 ft
Propeller RPM	80-90
Ship Speed (V_s)	20 knots
Number of Propeller Blades (z)	4 or 5
Wake Factor ($1-w$) (Levingston) (4/19)	0.932
Thrust Factor ($1-t$) (Levingston) (4/19)	0.8924

* Based on ABS (MCR) of Transamerica DeLaval/Stork Werkspoor 9 TM 620.

SHAFTING DESIGN and ARRANGEMENT

The shafting arrangement as originally conceived is shown in Figure 5-A-1. It is understood that the coupling, which is shown between the aft and intermediate struts, will be moved forward of the intermediate strut. Also, the shaft diameters were increased slightly to conform to ABS rules. Details are given in this section. The aft stern tube bearing is a tilting pad, oil lubricated bearing. The length of this type of bearing is only about one shaft diameter. The entire shaft turns inside a closure tube filled with oil.

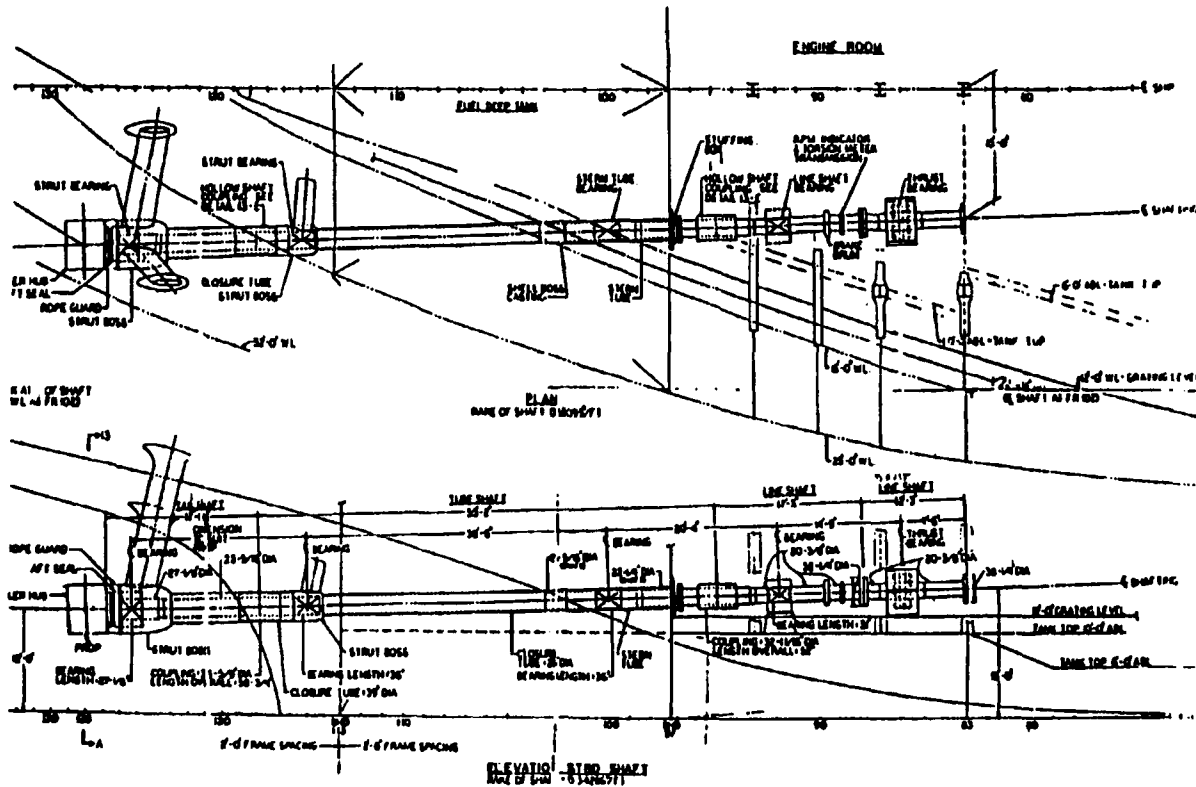

Figure 5-A-1
Preliminary Shafting Arrangement

4.1 Shaft Design

Shaft sizes were calculated in accordance with ABS rules [2] for a horsepower of 16,865, which is the maximum continuous rating (MCR) of the Transamerica DeLaval/Stork Werkspoor 9 TM 620.

It is understood that a revision to these rules is imminent, but that the new equations require the Ultimate Tensile Strength of the shaft material. For the T-AO 187 this was not available so the older version was used. The effect of the revised rules has been checked and found to be negligible.

Section 34.19 Line and Thrust Shafts requires the diameters to be:

$$d = c \sqrt[3]{\frac{H}{R}}$$

where :

- d = diameter in inches
- H = HP at rated speed = 16,865
- R = RPM at rated speed = 80 and 90
- c = a constant = 3.504 for line shafts
= 4.000 for thrust shafts

The required diameters are:

	<u>LINE SHAFT</u>	<u>THRUST SHAFT</u>
80 RPM	20.855"	23.808"
90 RPM	20.053"	22.892"

Section 34.23 Tube Shafts requires the tube shafts to be 1.2 times the line shafts:

	<u>TUBE SHAFT</u>
80 RPM	25.026"
90 RPM	24.064"

Section 34.25 Tail Shafts requires the least diameter to be 1.236 times the line shafts:

	<u>TAIL SHAFT</u>
80 RPM	25.777"
90 RPM	24.786"

Appendix 5-A - Example Problem

Section 34.27 Tail Shaft Liners requires the liner thickness at bearings to be 0.2 inch more than the tail shaft diameter divided by 25. For a continuous liner, the thickness between bearings must be 0.75 times that.

	<u>LINER THICKNESS</u>	
	At Bearings	Between Bearings
80 RPM	1.296"	0.9719"
90 RPM	1.255"	0.9410"

The above sizes refer to solid shafts. The T-AO 187 shaft has a 9-inch bore, d_i , to accommodate the controllable pitch propeller. To find the equivalent outside diameter, d_o

$$d_o = \sqrt[4]{d^4 + d_i^4}$$

For ice strengthening, ABS rules require a 5 percent increase in diameter, and the specifications require an additional 0.25 inch.

The resulting diameters were calculated and the next higher one eighth inch used in the analysis as shown in Table 5-A-1.

Table 5-A-1 Calculated Shaft Diameters in Inches

80 RPM				
Shaft	Solid	with 9" Bore	+5% + 1/4"	Required Size (next 1/8")
Line	20.855	21.034		21.125
Thrust	23.808	23.929		24
Tube	25.026	25.130		25.25
Tail	25.777	25.872	27.416	27.5
Liner at Bearings	1.296			1.375
Liner Between Bearings	0.9719			1

90 RPM				
Shaft	Solid	with 9" Bore	+5% + 1/4"	Required Size (next 1/8")
Line	20.053	20.253		20.375
Thrust	22.892	23.028		23.125
Tube	24.064	24.181		24.25
Tail	24.786	24.893	26.388	26.5
Liner at Bearings	1.255			1.375
Liner Between Bearings	0.941			1

BEARING ARRANGEMENT

The primary objective in arranging the propulsion shaft bearings is to provide adequate radial support for the propulsion shaft under normal conditions of operation. A special consideration is establishing and maintaining a proper gear-to-lineshaft relationship in order to minimize adverse effects of misalignment on the reduction gear components. This is usually accomplished by conducting a bearing reaction study and determining the sensitivity of bearing loads due to bearing wear and thermal growth of the reduction gear.

Since the available time in the preliminary study was insufficient to permit such an analysis, and since the reduction gear details were not available, a few "rules of thumb" will be used instead.

It is generally accepted that a length/diameter ratio of about 15-20, between the aftmost reduction gear bearing and the first line shaft bearing will provide sufficient flexibility to accommodate reduction gear thermal growth, setting errors and bearing wear without adversely affecting the bearing loads. Referring to Figure 5-A-1, we estimate a ratio of approximately 14 when using the 20 $\frac{3}{8}$ inch line shaft and approximately 13.5 when using the 21 $\frac{1}{8}$ inch line shaft. This is considered sufficiently close for the preliminary evaluation.

The only other major concern regarding the placement of bearings is that they not be spaced too far apart from a lateral vibration point of view. However, this is taken care of in Section 8 dealing with lateral vibrations since the only large spans are those in the outboard shafting.

Another consideration regarding the placement of bearings is the vulnerability of the shafting system to underwater explosion. In order to minimize any such damage to the shafting system, the bearings should be placed, insofar as possible, on so-called "hard spots." Such spots would tend to deflect less from an underwater explosion and therefore minimize deformation of the shaft system. The optimum hard spots would be the bulkheads, which form continuous rigid supports from the ship's bottom to the upper decks; however, these locations may not be practical in this case. As an alternative, it is suggested that consideration be given to locating the line shaft bearings on deep frames. Based on the limited drawings available at this time, it appears that locating the bearings on Frame 93, rather than 92, would satisfy that requirement and simultaneously provide the additional distance between the lineshaft and aft reduction gear bearing indicated previously.

In the Phase II design stage, a more thorough analysis should be carried out to fully develop the various characteristics and interrelationship of the shafting system components.

ESTIMATED PROPELLER FORCES

Reference [1] estimates the propeller forces that are used for this analysis as follows:

	80 RPM	90 RPM
\bar{T} Steady Thrust, lbs	161,000	161,000
\bar{Q} Steady Torque, ft-lbs	868,000	772,000
\tilde{T} Alternating Thrust, lbs	2,300(1.4%)	2,000(1.2%)
\tilde{Q} Alternating Torque, ft-lbs	8,700(1.0%)	5,400(.7%)

The specifications require the following factors to be applied to the blade rate excitation forces:

<u>TYPE of EXCITATION</u> <u>and OPERATION</u>	<u>CORRECTION FACTORS</u>	
	<u>0-90% Rated RPM</u>	<u>100-120% Rated RPM</u>
Average Excitation, Straight	1	3
Peak Excitation, Straight	3	9
Peak Excitation, Maneuvering	9	27

Reference [1] presents a more refined definition of such factors and suggests the alternating thrust be related to four operating conditions:

<u>BOTTOM</u>	<u>RPM</u>	<u>SPEED</u>	<u>EHP/SH</u>	<u>T/SH</u>	<u>SEAS</u>
A. Clean	90%	18 knots	6,000	121,800	Calm
B. Clean	100%	20 knots	8,800	161,000	Calm
C. Fouled	100%	20 knots	11,240	205,600	Calm
D. Fouled	100%				Rough

The alternating thrusts associated with these operating conditions are taken from Table 6 of Reference [1] and relate to the alternating thrust of $\pm 2,300$ pounds (1.4 percent) associated with operation at 80 RPM.

<u>TYPE of EXCITATION</u> <u>and OPERATION</u>	<u>CONDITION</u>			
	<u>A</u>	<u>B</u>	<u>C</u>	<u>D</u>
Average Excitation, Straight, lbs	$\pm 1,700$	$\pm 3,450$	$\pm 5,800$	$\pm 8,700$
Peak Excitation, Straight, lbs	$\pm 3,400$	$\pm 6,900$	$\pm 11,600$	$\pm 17,400$
Peak Excitation, Maneuvering, lbs	$\pm 8,500$	$\pm 17,250$	$\pm 29,000$	$\pm 43,500$

For this analysis we will calculate the response for the peak excitation, straight course, and maneuvering using the factors in the specifications and the most severe condition ($\pm 43,500$ pounds) from the above table. That amount of alternating thrust can be expressed as a correction factor of 19 relative to the input force of $\pm 2,300$ pounds at 100 percent rated RPM.

LONGITUDINAL VIBRATION

6.1 Longitudinal Natural Frequencies

In order to estimate the longitudinal natural frequency of the propulsion system, the model shown in Figure 5-A-2 was used. As inputs to the model, Figure 5-A-3 shows the assumed dimensions of the shaft for purposes of calculating stiffnesses. The propeller characteristics were estimated by Bird Johnson Company as shown in Table 5-A-2 and forwarded by Reference [4]. The stiffnesses and masses are calculated in Tables 5-A-3 and 5-A-4 for 80 and 90 RPM and for four and five blades. The value for M_2 is assumed because data on the reduction gear is not yet available.

- M_1 = Mass of Propeller + 50% for Entrained Water, and $\frac{1}{2}$ the Shafting
- M_2 = Mass of $\frac{1}{2}$ the Shafting, all of the Reduction Gears and Casing
- K_1 = Stiffness of Shafting
- K_2 = Stiffness of Thrust Bearing and Machinery Foundation in Series

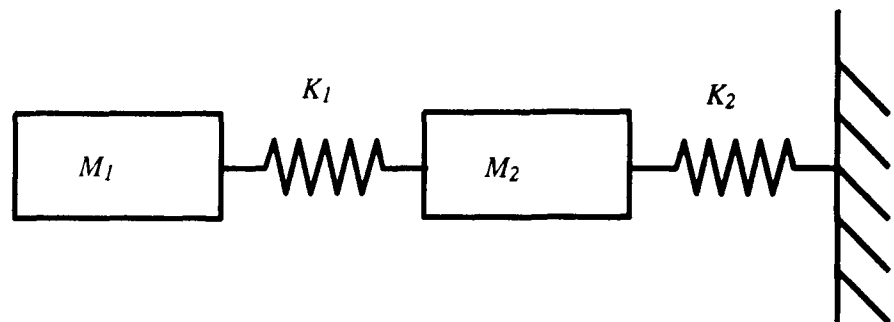

Figure 5-A-2

Mass-Elastic Model for Longitudinal Shaft Vibration

The thrust bearing will be an eight-shoe, 40-inch diameter bearing which, according to Reference [5], will have a stiffness of about 27×10^6 lb/in. The housing will have a stiffness of about 10×10^6 lb/in, and the foundation is estimated to be about 16×10^6 lb/in, also based on data in Reference [5]. The combined stiffness is 5.01×10^6 lb/in, which is the estimated value for K_2 . With these assumptions the natural frequencies and mode shapes are calculated and shown in Table 5-A-2. The natural frequency does not change significantly with the number of blades but, naturally, the critical shaft speed does.

Appendix 5-A - Example Problem

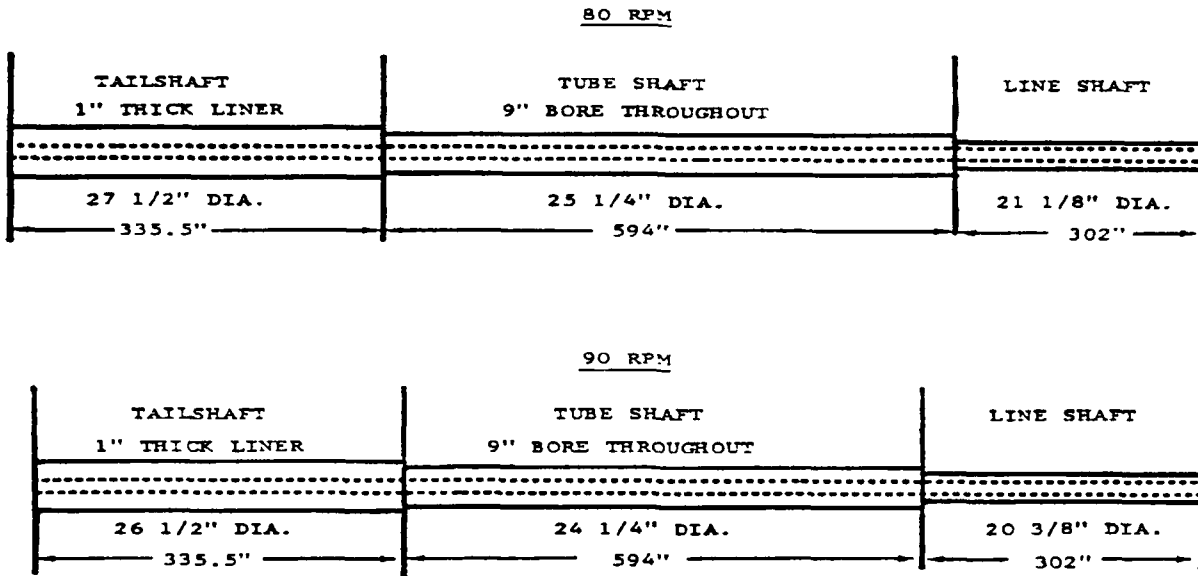

Figure 5-A-3

Assumed Dimensions of Shafts Used for Calculating Stiffness

Table 5-A-2 Longitudinal Natural frequencies and Mode Shapes

RPM	Blades	Natural Frequency, Hz	Critical RPM (for Blade Rate)	Mode Shape (X ₂ / X ₁)
80	4	9.68	145	0.781
	5	9.65	116	0.781
90	4	10.00	150	0.763
	5	9.97	120	0.763

Table 5-A-3 Shaft Stiffnesses

RPM	Shaft	Outside Diameter (Inches)	Inside Diameter (Inches)	Length (Inches)	Axial Stiffness* (lb/in)	Torsional Stiffness** (In-lb/rad)
80	Tail	27.5	9	335.5	47.42 x 10 ⁶	1952 x 10 ⁶
	Liner	29.5	27.5	335.5	4.27 x 10 ⁶	391 x 10 ⁶
	Tube	25.25	9	594	22.08 x 10 ⁶	780 x 10 ⁶
	Line	21.125	9	302	28.50 x 10 ⁶	739 x 10 ⁶
	Combined	***	***	***	10.02 x 10 ⁶	326.6 x 10 ⁶
90	Tail	26.5	9	335.5	43.63 x 10 ⁶	1680 x 10 ⁶
	Liner	28.5	26.5	335.5	4.13 x 10 ⁶	351 x 10 ⁶
	Tube	24.25	9	594	20.11 x 10 ⁶	689.9 x 10 ⁶
	Line	20.375	9	302	26.07 x 10 ⁶	635.9 x 10 ⁶
	Combined	***	***	***	9.17 x 10 ⁶	284.5 x 10 ⁶

Ship Vibration Design Guide

* Axial Stiffness, $K_a = \frac{AE}{L} = \frac{\pi(OD^2 - ID^2) \times 30 \times 10^6}{4L}$

** Torsional Stiffness, $K_t = \frac{GJ}{L} = \frac{11.8 \times 10^6 \times \pi(OD^4 - ID^4)}{32L}$

*** $\frac{1}{K_{COMB}} = \frac{1}{K_{TAIL} + K_{LINER}} + \frac{1}{K_{TUBE}} + \frac{1}{K_{LINE}}$

Table 5-A-4 Calculation of Masses

Shaft Item	Length (Inches)	Outside Diameter (Inches)	Inside Diameter (Inches)	Mass* (lb-sec ² /In)	Outside Diameter (Inches)	Inside Diameter (Inches)	Mass* (lb-sec ² /In)	
Tail Shaft	300.5	27.5	9	116.7	26.5	9	107.4	
T S. Liner**	300.5	29.5	27.5	22.3	28.5	26.5	21.5	
T.S. End	35	25.25	9	11.2	24.25	9	10.2	
Coupling	60	38.5	25.25	29.2	37.5	24.25	28.2	
Tube Shaft	542	25.25	9	173.5	24.25	9	158.1	
Liner**	72	27.875	25.25	6.6	26.875	24.25	6.3	
Coupling	52	33.25	25.25	14.0	32.25	24.25	13.5	
Line Shaft-Lg	52	25.25	9	16.6	24.25	9	15.2	
Line Shaft-Sm	155	21.125	9	32.6	20.375	9	29.8	
Thrust-Sm	39	21.125	9	8.2	20.375	9	7.5	
Thrust-Lg	36	24	9	10.3	23.125	9	9.4	
Thrust-Sm	72	21.125	9	15.1	20.375	9	13.8	
Shaft Total:				456.3	Shaft Total:			420.9

* Mass = $\rho \frac{\pi}{4} (OD^2 - ID^2) \times \frac{L}{386.4}$, $\rho = 0.283$ for steel

** Bronze, $\rho = 0.320$ lb / in³

RPM	Blades	Propeller Mass (including 50%)	Mass of Half Shaft	M ₁	M ₂
80	4	365.3	228.2	593.5	Assume
	5	369.6	228.2	597.8	same
90	4	338.5	210.5	549.0	as
	5	342.0	210.5	552.5	M ₁

Table 5-A-5 Characteristics of T-AO 187 Propeller

	80 RPM		90 RPM	
	Four Blades	Five Blades	Four Blades	Five Blades
Diameter, ft	24	24	24	24
EAR	0.66	0.66	0.50	0.50
P/D @ 0.7R			1.25	1.13
Weight, lbs	94,100	95,200	87,200	88,100
WR ² (in air), lb-ft ²	2,292,400	2,386,400	1,984,000	2,115,000

Since these frequencies were calculated on the basis of rough estimates of K_2 and M_2 , a study was made to find how the fundamental frequency changes with changes in K_2 and M_2 . Figure 5-A-4 shows the results, which apply to both four and five-bladed systems. The reduction gear mass cannot be changed much from whatever is required, but care should be taken in the foundation design to make it as rigid as is practical.

LONGITUDINAL RESPONSE

The axial response was calculated for the 80 and 90 RPM systems with four and five blades. The resonant condition is outside the operating speed range in all cases, so no resonant amplitudes need be calculated. For the specified operating speeds it will be assumed that the dynamic magnifier, Q , for the alternating thrust and bull gear amplitude can be given by:

$$Q = \frac{1}{1 - \left(\frac{f}{f_n}\right)^2}$$

where:

$$\begin{aligned} f &= \text{Blade Rate at Operating Speed, Hz} \\ f_n &= \text{Axial Natural Frequency, Hz} \end{aligned}$$

This is true for a single-degree-of-freedom system and a reasonable approximation for our system below resonance. The amplitude of the bull gear X_g is:

$$X_g = QX_s$$

where:

$$X_s = \text{PK. EXC.} / K_2, \text{ the Static Deflection of } X_2$$

With these assumptions, the alternating thrust at the thrust bearing and the bull gear amplitude will be calculated (see Table 5-A-6) for the following conditions:

- 90%, 100% and 120% of Rated RPM
- Peak Excitation
- Straight Course and Maneuvering

At rated speed, the only quantity exceeding specified limits is the alternating thrust at the thrust bearing in turns. The percentages given reflect a worse condition for the five-bladed propellers. This may not actually be the case because the five-bladed propeller is likely to have less excitation than the four-bladed. The data used to estimate forces in Reference [1] did not distinguish between the two, but there is much evidence to that effect. Reference [6], for example, estimates the pressure forces of a five-bladed propeller to be about 77 percent of the four-bladed. If we assume the four-bladed calculations are correct and the five-bladed alternating thrusts are 77 percent of the calculations, then all of the alternating thrusts are essentially the same varying only from 50 percent to 57 percent.

Ship Vibration Design Guide

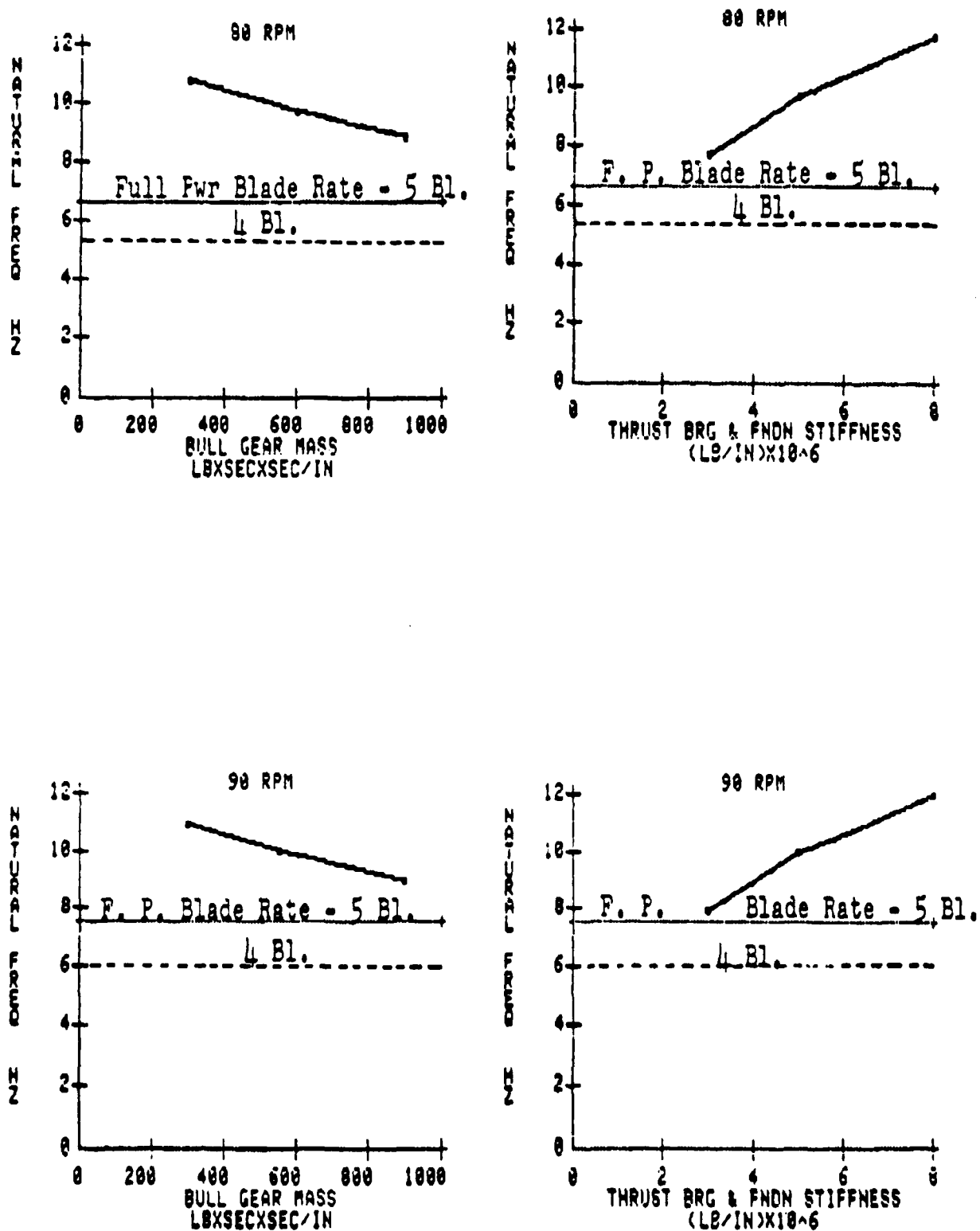

Figure 5-A-4

Axial Natural Frequency vs. Bull Gear Mass and Thrust Bearing/Foundation Stiffness

Table 5-A-6 Calculated Response Amplitudes

90 Percent of Rated RPM												
RPM	Blades	\tilde{T} (% \bar{T})	Pk Exc Factr	Pk Exc		90% Bld Rt	Res Freq	Q	Alt Thrust @ Thrust Brg-% \bar{T}		Bull Gear Defl (mils)	
				% \bar{T}	lbs				Straight	Turns	Straight	Turns
80	4	1.4	3	4.2	6762	4.80	9.68	1.33	5.57	16.7	1.80	5.40
	5	1.4	3	4.2	6762	6.00	9.65	1.63	6.83	20.5	2.20	6.60
90	4	1.2	3	3.6	5796	5.40	10.00	1.41	5.08	15.2	1.63	4.89
	5	1.2	3	3.6	5796	6.75	9.97	1.85	6.65	19.9	2.14	6.42

100 Percent of Rated RPM												
RPM	Blades	\tilde{T} (% \bar{T})	Pk Exc Factr	Pk Exc		90% Bld Rt	Res Freq	Q	Alt Thrust @ Thrust Brg-% \bar{T}		Bull Gear Defl (mils)	
				% \bar{T}	lbs				Straight	Turns	Straight	Turns
80	4	1.4	9	12.6	20286	5.33	9.68	1.44	18.1	54.4	5.83	17.5
	5	1.4	9	12.6	20286	6.66	9.65	1.91	24.1	72.2	7.73	23.2
90	4	1.2	9	10.8	17388	6.00	10.00	1.56	16.8	50.5	5.41	16.2
	5	1.2	9	10.8	17388	7.50	9.97	2.30	24.8	74.5	7.98	23.9

120 Percent of Rated RPM												
RPM	Blades	\tilde{T} (% \bar{T})	Pk Exc Factr	Pk Exc		90% Bld Rt	Res Freq	Q	Alt Thrust @ Thrust Brg-% \bar{T}		Bull Gear Defl (mils)	
				% \bar{T}	lbs				Straight	Turns	Straight	Turns
80	4	1.4	9	12.6	20286	6.4	9.68	1.78	22.4	67.3	7.21	21.6
	5	1.4	9	12.6	20286	8.0	9.65	3.20	40.3	121.0	12.96	38.9
90	4	1.2	9	10.8	17388	7.2	10.00	2.08	22.5	67.4	7.22	21.7
	5	1.2	9	10.8	17388	9.0	9.97	5.40	58.3	175.0	18.70	56.2

At 90 percent of rated speed, all specified limits are satisfied. At 120 percent of rated speed, when using the correction factors called for by the specifications, the alternating thrust obtained in a hard turn exceeds the 50 percent of steady thrust limit for all combinations of RPM and number of propeller blades. The combination of five-bladed propeller and 90 RPM also exceeds the limit on the straight course. Old analysis also indicates the bull gear exceeds the 30-mil limit prescribed for the thrust bearing (both the gear and thrust bearing housing will have essentially the same response) when using the five-bladed propeller.

As noted in the earlier NKF study [1], the requirement of MIL-STD-167 [8], relative to the allowable gear tooth stress, has been omitted from the T-AO 187 specification. Two things are obvious at this point. First, with the level of alternating thrust present in the system used in the preliminary analysis, the alternating gear tooth stresses would be expected to seriously exceed the gear tooth load capacity and, second, the requirement for the large correction factors and operation at 120 percent of rated speed seriously impacts the viability of the propulsion system, as contemplated. As was shown in Table 7 of the previous NKF study [1], we must operate between the longitudinal and torsional criticals. Thus, the application of generous correction factors and the omission of appropriate gear tooth stress limits are considered inappropriate.

Ship Vibration Design Guide

One reason the allowable gear tooth stress limitation, specified in MIL-STD-167, may have been omitted is that it may be too restrictive as written. Experience would tend to confirm this. As an alternative, it should provide that "excessive alternating thrust in the reduction gear occurs when the vibratory stress in the gear teeth exceeds the allowable limits established by the gear manufacturer."

To resolve this problem, a more accurate method of predicting true propeller input forces and the optimization of the underwater details of the design to minimize these forces, as recommended in the earlier report [1], should be employed. This should go a long way in reducing the first correction factor applied to the 90-100 percent speed range. Secondly, a more accurate assessment of appropriate correction factors associated with the expected ship operating characteristics may justify the reduction of the presently stipulated 120 percent rated speed. And, finally, the detailed system analysis required under Phase II should permit evaluation of gear tooth loading against the allowable loading specified by the gear manufacturer.

There is no doubt that the longitudinal response at full power must be carefully considered in the final design and in the decision as to the number of blades. Detailed longitudinal calculations should include a finite element representation of the foundation structure.

When the same responses are calculated for the recommended alternating thrust from Reference [1] at 100 percent of rated speed, the following (including effects of modulation, cavitation, fouled bottom, maneuvers, and rough seas) are obtained:

100 Percent of Rated RPM										
RPM	Blades	\tilde{T} (% \bar{T})	Pk Exc Factr	Pk Exc		100% Bld Rt	Res Freq	Q	Alt Thrust @ Thrust Brg-% \bar{T}	Bull Gear Defl (mils)
				% \bar{T}	lbs					
80	4	1.4	19	26.6	42,826	5.33	9.68	1.44	38.3	12.3
	5	1.4	19	26.6	42,826	6.66	9.65	1.91	50.8	16.3
	4	1.2	19	22.8	36,708	6.00	10.00	1.56	35.6	11.4
	5	1.2	19	22.8	36,708	7.50	9.97	2.30	52.4	16.9

TORSIONAL VIBRATION

7.1 Torsional Natural Frequencies

The torsional model of the propulsion system is shown in Figure 5-A-5. The propeller inertias are given in Table 5-A-2. The bull gear and pinion inertias were estimated from that of a similar ship. The engine inertia is that of the 9 TM 620 engine as provided by DeLaval. The PTO inertia is that of a Siemens 2000 kW unit, similar to that will be installed.

The shaft stiffnesses are from Table 5-A-3. The coupling stiffnesses were taken from an Eaton/Airflex catalog. The average stiffnesses for all the couplings for the appropriate torque ratings were used.

Appendix 5-A - Example Problem

So many assumptions had to be made that the results have to be considered very rough. The values of the parameters used for the 80 and 90 RPM systems are shown in Figure 5-A-5. The only difference between the four- and five-bladed systems was the propeller inertias, which differed by less than seven percent, where averages were used. The high speed components are multiplied by the gear ratios squared, based on 430 engine RPM.

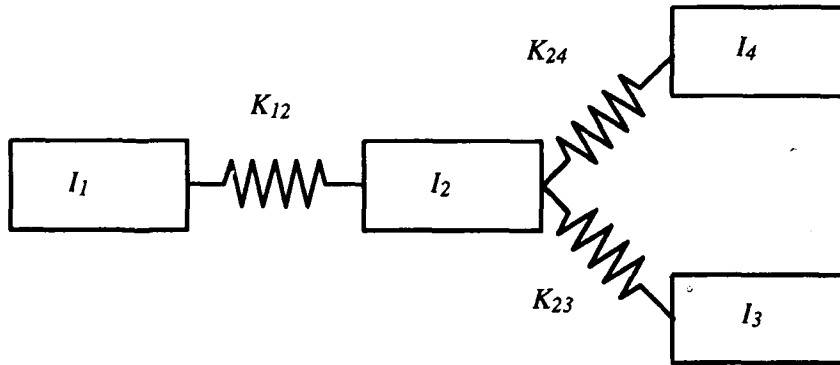

- I_1 = Inertia of Propeller plus 25% for Entrained Water
- I_2 = Inertia of Bull Gear and Pinions
- I_3 = Inertia of Diesel Engine
- I_4 = Inertia of PTO
- K_{12} = Stiffness of Propeller Shaft
- K_{23} = Stiffness of Engine Coupling
- K_{24} = Stiffness of PTO Coupling

RPM	I_1	I_2	I_3	I_4	K_{12}	K_{23}	K_{24}
80	1.09	0.1	2.31	.668	326.6	1156	927
90	0.995	0.1	1.82	.528	284.5	912	732

Figure 5-A-5
Torsional Mass-Elastic System

Ship Vibration Design Guide

The natural frequencies of the systems are:

RPM	1st MODE	2nd MODE	3rd MODE
80	2.93 Hz	5.09 Hz	25.12 Hz
90	2.94 Hz	5.10 Hz	22.57 Hz

The mode shapes are very similar for both cases and are given in Figure 5-A-6.

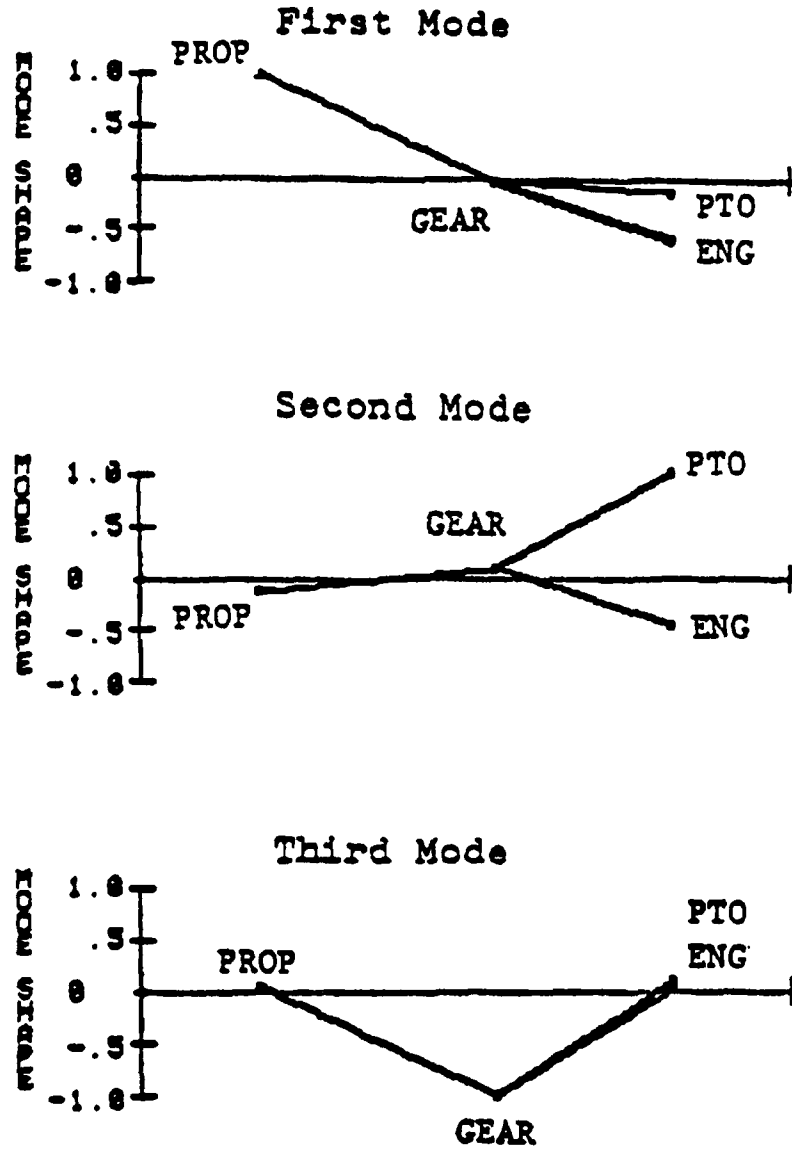

Figure 5-A-6
Torsional Mode Shapes

Only the first and second modes are in the operating speed range, and the second mode would not be excited very efficiently by propeller forces.

In order to anticipate the effect of the stiffnesses and inertias being different than assumed, several parametric studies were performed as shown in Figures 5-A-7 and 5-A-8. These show that the first mode is fairly independent of those changes, but the second mode is quite dependent.

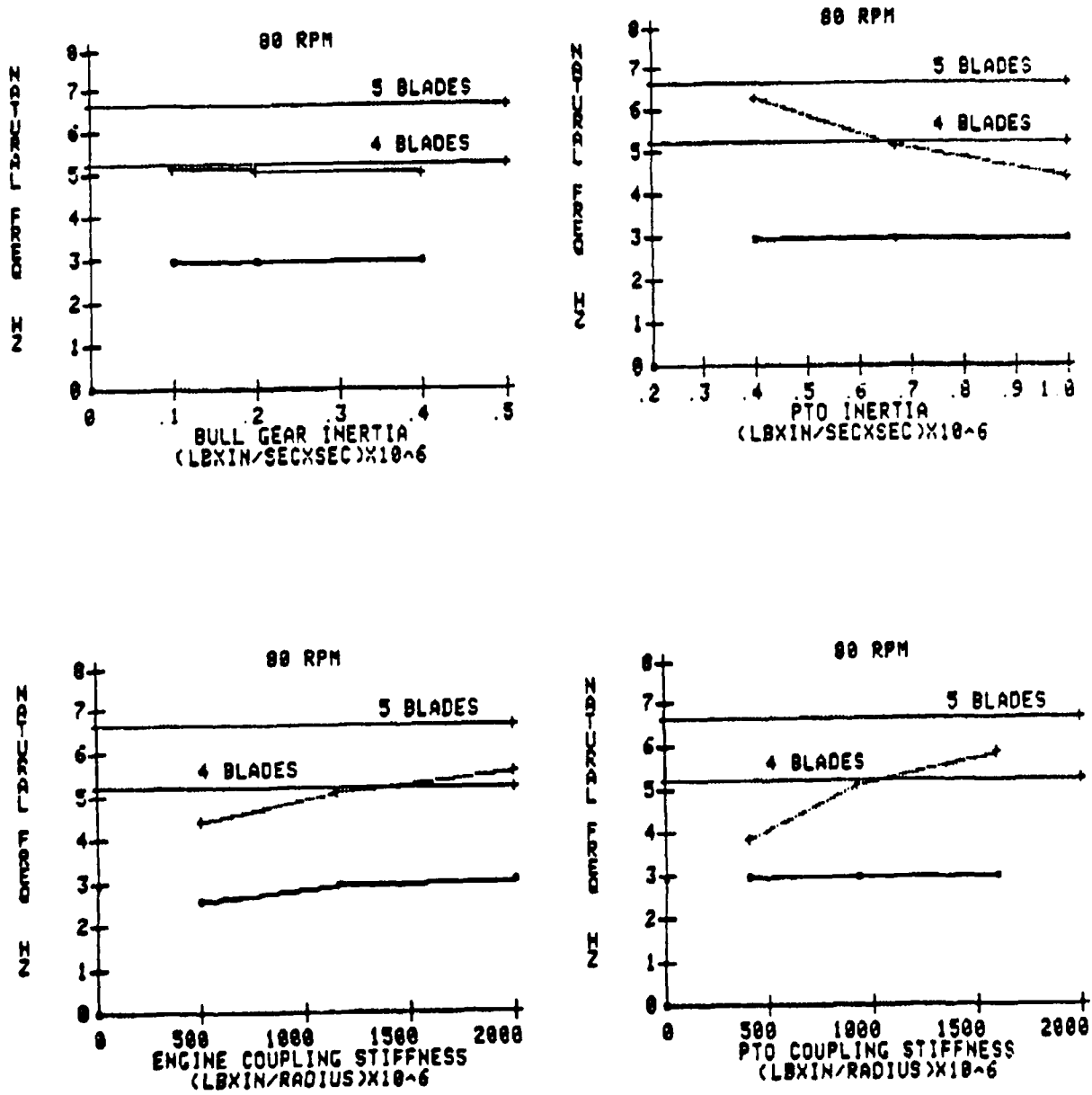

Figure 5-A-7

Torsional Natural Frequencies versus Coupling Stiffnesses and Bull Gear and PTO Inertias for 80 RPM System

Ship Vibration Design Guide

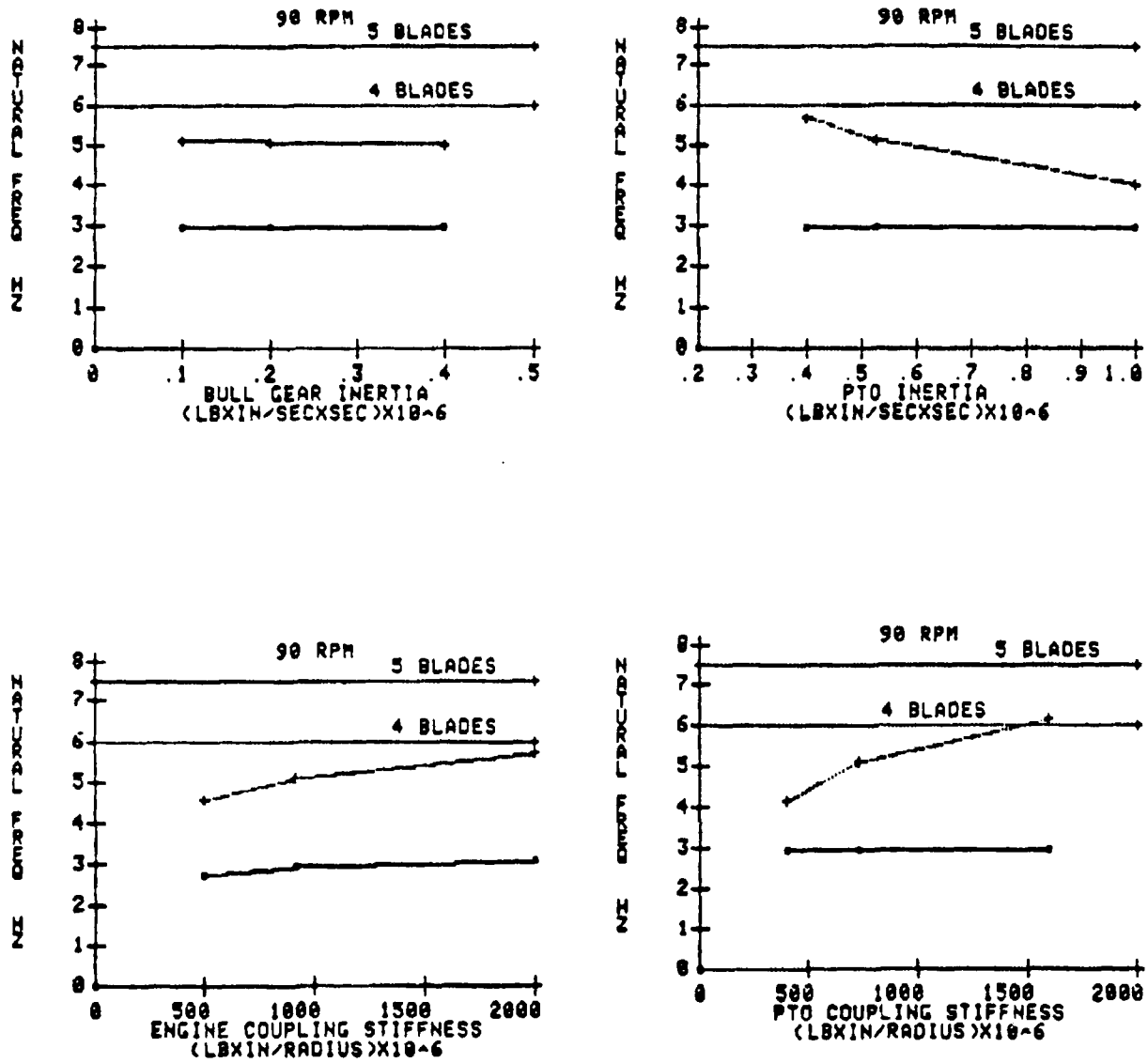

Figure 5-A-8

Torsional Natural Frequencies versus Coupling Stiffnesses and Bull Gear and PTO Inertias for 90 RPM System

The first mode, which is of primary concern, will coincide with blade-rate at the following shaft speeds (assuming a 2.93 Hz natural frequency).

RPM	Blades	Critical RPM	% of Rated Speed
80	4	44	55
	5	35	44
90	4	44	49
	5	35	39

7.2 Torsional Response

Since a torsional resonance occurs within the operating speed range, the maximum response must be calculated at resonance as well as full power. The specifications apply to speeds up to 120 percent of rated RPM, so that point will also be considered.

7.2.1 Resonance

For resonant response, damping must be estimated. Reference [7] suggests the following formula:

$$C_p = 30 \frac{Q_c}{N_c}$$

where:

- C_p = Propeller Damping, in-lb-sec / rad
- Q_c = Propeller Torque at Critical Speed in-lb (a function of RPM²)
- N_c = Propeller RPM at Critical Speed

This results in:

RPM	Blades	% of Rated RPM	\bar{Q} @ Full Power	\bar{Q}_c	N_c	C_p
80	4	55	10.42×10^6	3.15×10^6	44	2.15×10^6
	5	44	10.42×10^6	2.02×10^6	35	1.73×10^6
90	4	49	9.264×10^6	2.22×10^6	44	1.51×10^6
	5	39	9.264×10^6	1.41×10^6	35	1.21×10^6

The propeller amplitude, θ_p , is given by:

$$\theta_p = \frac{\tilde{Q}_p}{C_p \omega_n}$$

RPM	Blades	\bar{Q}_c	\tilde{Q} % of \bar{Q}	\tilde{Q}^*	C_p	ω_n	θ_p
80	4	3.15×10^6	1.0	283,500	2.15×10^6	18.41	.00716
	5	2.02×10^6	1.0	181,800	1.73×10^6	18.41	.00571
90	4	2.22×10^6	0.7	139,860	1.51×10^6	18.47	.00501
	5	1.41×10^6	0.7	88,830	1.21×10^6	18.47	.00397

* With peak excitation and maneuvering factor of 9

To find the stresses in the shaft, the torque must be found with the aid of the mode shape:

RPM	Blades	θ_2/θ_1	$\theta_1 - \theta_2$	K_{12}	$\tilde{Q}_c = K_{12} (\theta_1 - \theta_2)$
80	4	-.0404	.00745	326.6×10^6	2.43×10^6
	5	-.0404	.00594	326.6×10^6	1.94×10^6
90	4	-.0467	.00524	284.5×10^6	1.49×10^6
	5	-.0467	.00416	284.5×10^6	1.18×10^6

Ship Vibration Design Guide

The alternating shear stress in the shafts, \tilde{S}_s , can be calculated from:

$$\tilde{S}_s = \frac{\tilde{Q}D}{2J}$$

where J is the polar moment of inertia of the shaft section.

RPM	Blades	\tilde{Q}	Tail Shaft			Tube Shaft			Line Shaft		
			D	J	\tilde{S}_s	D	J	\tilde{S}_s	D	J	\tilde{S}_s
80	4	2.43×10^6	27.5	55,503	602	25.25	39,262	781	21.125	18,908	1357
	5	1.94×10^6	27.5	55,503	481	25.25	39,262	624	21.125	18,908	1084
90	4	1.49×10^6	26.5	47,771	413	24.50	34,728	526	20.375	16,276	933
	5	1.18×10^6	26.5	47,771	327	24.50	34,728	416	20.375	16,276	739

All of these alternating stresses are below the $\pm 1,700$ psi limit imposed by the ABS rules. Even though the torsional requirements of MIL-STD-167 [8] were not invoked, it was considered worthwhile to see if the requirements were met. The stress limits are not as restrictive as the ABS limits, so that is no problem. MIL-STD-167 also requires the alternating torque to be less than 75 percent of the steady torque at any speed and less than 25 percent of the full power steady torque. For the propulsion shafting, the ratio of alternating torque to steady torque is found to be:

RPM	Blades	\tilde{Q}_c	\bar{Q}_c	\tilde{Q}_c/\bar{Q}_c	\bar{Q}_{FP}	\tilde{Q}_c/\bar{Q}_{FP}
80	4	2.43×10^6	3.15×10^6	77%	10.42×10^6	23%
	5	1.94×10^6	2.02×10^6	96%	10.42×10^6	19%
90	4	1.49×10^6	2.22×10^6	67%	9.264×10^6	16%
	5	1.18×10^6	1.41×10^6	84%	9.264×10^6	13%

The 75-percent limit is exceeded in three of the four cases. The response at resonance should be of concern, but more detailed calculations should be made before any conclusions can be drawn.

7.2.2 Rated Speed

At rated speed we will assume that the dynamic magnifier, Q , is given by the single degree-of-freedom equation:

$$Q = \frac{1}{1 - \left(\frac{f}{f_n}\right)^2}$$

The calculation of alternating torques would then be:

RPM	Blades	\bar{Q}_{FP}	\tilde{Q} % of \bar{Q}	\tilde{Q}_p^*	f_{FP}/f_n	Q	\tilde{Q}_s	\tilde{Q}_s/\bar{Q}_{FP}
80	4	10.42×10^6	1.0	2.813×10^6	1.82	0.433	1.218×10^6	11.7%
	5	0.42×10^6	1.0	2.813×10^6	2.27	0.240	0.675×10^6	6.5%
90	4	9.264×10^6	0.7	1.751×10^6	2.04	0.316	0.533×10^6	6.0%
	5	9.264×10^6	0.7	1.751×10^6	2.55	0.182	0.319×10^6	3.4%

* Includes peak excitation, full power, and maneuvering factor of 27

These are all below the limit of 25 percent specified in MIL-STD-67. The stresses associated with these alternating torques are low:

RPM	Blades	\tilde{Q}_{FP}	Alternating Torsional Shear Stress at Rated Speed		
			Tail Shaft Stress, psi	Tube Shaft Stress, psi	Line Shaft Stress, psi
80	4	1.218×10^6	302	391	680
	5	0.675×10^6	167	217	377
90	4	0.533×10^6	153	195	346
	5	0.319×10^6	88	112	200

7.2.3 120 Percent of Rated Speed

The excitation for this speed would have the same magnitude, but the dynamic magnifier would be less because the shaft is operating farther away from resonance. Therefore, all the alternating torques and stresses would be below those for rated speed, and would be acceptable by a wide margin.

Only the first mode was considered for torsional response. More detailed calculations may prove that the second mode has a significant contribution and when the complete system details have been determined, the detailed analyses carried out under Phase II of the design may indicate that other sections of the complete system, including the engine and PTO, may exhibit excessive vibratory stresses in other than the propulsion shafting and/or result in gear rattle within important operating speeds. For example, a rough estimate of the vibratory torque, between the engine and reduction gear, at the fifth order critical, occurring at 39 percent of the rated speed of 90 RPM would be approximately 160 percent of the steady driving torque. While a pass through critical below operating speed, which produces gear rattle, is not unusual, it is considered necessary to provide specific design criteria such as given in MIL-STD-167 to ensure the complete system is free from damaging levels of torsional vibration, whether excited by the engine or propeller. The ultimate selection of number of propeller blades and rated RPM will depend heavily on the compromise between the torsional and longitudinal propulsion system dynamics.

LATERAL VIBRATION

The lateral critical speed of ship propulsion systems is normally much higher than the operating RPM. If that is the case, response calculations need not be made. For purposes of this preliminary study three approximate formulas were used to calculate the critical speed.

Panagopulos' Formula:

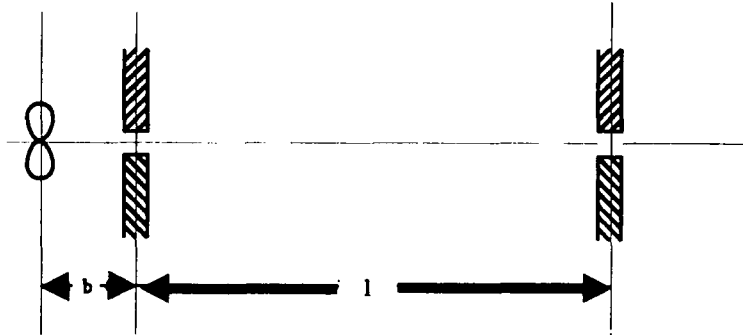

$$f = \frac{30}{\pi} \sqrt{\frac{iE}{I_x \left(b + \frac{l}{3}\right) + W_p \frac{b^2}{g} \left(\frac{b+l}{2} + \frac{l}{3}\right) + \mu \left(\frac{b^4}{8} + \frac{lb^3}{9} + \frac{7l^4}{360}\right)}$$

where:

- f = Cycles per Minute
- i = Shaft Moment of Inertia About the Diameter = $D^4/64$, in^4
- I_p = Mass Moment of Inertia of Propeller About its Axis, lb-in-sec^2
- I_x = Mass Moment of Inertia of Propeller About its Diameter, plus 60% for Entrained Water, lb-in-sec^2
- W_p = Weight of Propeller, including Shaft Stub, Nut, and Hub Cap plus 25% for Entrained Water, lbs (air)
- μ = Shaft Mass per Inch = W/g $\text{lb-sec}^2 / \text{in}^2$
- E = Young's Modulus = 30×10^6 lbs / in^2
- b = Distance of Propeller Centerline to Bearing Centerline = 66.5 in
- l = Bearing Centerline Distance = 246.5 in

For the four cases studied, the inputs and results are:

RPM	Blades	I	I_d	m	μ	f
80	4	27,751	0.6835×10^6	316.5	0.4626	501.9
	5	27,751	0.7117×10^6	320.3	0.4626	496.9
90	4	23,886	0.5915×10^6	293.4	0.4290	489.2
	5	23,886	0.6305×10^6	296.4	0.4290	482.7

Jasper Formula:

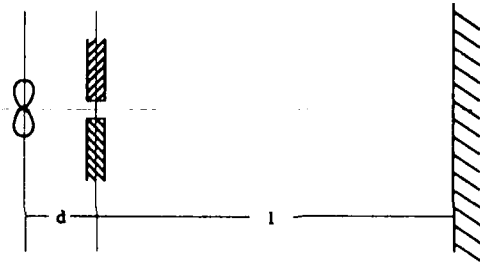

$$\Omega_1 = \sqrt{\frac{I}{\delta_p (m + m_{es})}}$$

where:

$$\delta_p = \frac{d^2}{EI} \left(\frac{d}{3} + \frac{L}{4} \right)$$

Ω_1 = Natural frequency, CPM

m = Propeller Mass plus 10 Percent Entrained Water

m_{es} = .38 x Shaft Mass, lb-sec² / in

d = 66.5 in

L = 246.5 in

I = Diametrical moment of inertia of shaft, in⁴

For the four cases studied, the inputs and results are:

RPM	Blades	m	m_{es}	I	Ω_1	f , CPM
80	4	267.9	173.4	27,751	71.36	681
	5	271.0	173.4	27,751	71.11	679
90	4	248.2	159.9	23,886	68.84	657
	5	250.8	159.9	23,886	68.62	655

Hesse Formula:

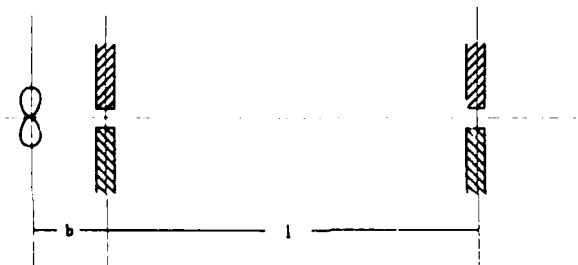

$$N_1 = 187.7 \sqrt{\frac{I}{y_1}} < \sqrt{\frac{I}{L + B}}$$

Ship Vibration Design Guide

where:

$$y_1 = \frac{WL^3}{3EI}$$

N_1 = Natural frequency, CPM

W = Propeller Weight without Entrained Water, lb-sec² / in

L = 66.5 in

B = 246.5 in

E = Young's Modulus = 30×10^6 lbs / in²

I = Shaft Moment of Inertia About the Diameter = $D^4/64$, in⁴

RPM	Blades	W	I	N_1
80	4	94,100	27,751	822
	5	95,200	27,751	817
90	4	87,200	23,886	793
	5	88,100	23,886	788

In the case of the T-AO 187, the span between the intermediate strut and stern tube is significantly longer than the span between the struts. The natural frequency of that span may be lower than that of the propeller and first span as just calculated. The formula for a pinned beam will be used to approximate that frequency:

$$\omega_n = 9.87 \sqrt{\frac{EI}{\mu l^4}}$$

where:

ω_n = Natural frequency, rad / sec

E = Young's Modulus = 30×10^6 lbs / in²

I = Shaft Moment of Inertia About the Diameter = $D^4/64$,

μ = Shaft Mass per Inch = w/g lb-sec² / in²

l = Length of Beam = 438 in

For the two different shaft speeds the inputs and results are:

RPM	I	μ	ω_n	f, CPM
80	19,631	0.320	69.3	661
90	16,653	0.292	67.3	642

The critical speeds calculated for the shaft range from 483 to 822 CPM, all of which are far above the shaft operating speed. Therefore, no problems are expected regarding lateral shaft vibration.

For reference purposes, the Jasper method provides an approximate solution for the first order forward whirl (which presents the greatest potential danger to a ship's propeller shaft system). This mode would be excited by mass unbalance. The Panagopulos method does not contain the whirl effect. Other than this, the only significant difference between the two methods is that the effect of the shaft mass is considerably greater in the Panagopulos method (about five times greater). For this reason the Panagopulos method consistently yields lower frequencies and is used in Reference [3].

EVALUATION of SHAFT STRENGTH

For shaft strength calculations, Reference [3] was used except for the calculation of torsional stresses. For that a more detailed model than suggested was appropriate. It should be noted that Reference [3] was not invoked in the ship specifications. The only document specified was the ABS rules.

For the shaft strength calculations the torque was assumed to be 10 percent more than rated torque. Steady stresses were calculated on the basis of torque and thrust. Alternating stresses included torque, thrust, and bending. For the bending, the off-center thrust was assumed to cause as much bending stress as the propeller overhang. The aft strut bearing reaction was assumed to be in the center of the bearing. (The recommended reaction point in [3] is for different types of bearings.)

The criteria for acceptance in Reference [3] are a bending stress of less than 6000 psi in the tail shaft, and a safety factor of 1.75 for inboard shafting and 2.0 for waterborne shafting when the alternating and steady stresses are considered in a Goodman-type diagram.

9.1 Steady Stress

The shear stress due to torque is:

$$S_s = 5.1 \left(\frac{\bar{Q} \times D}{D^4 - d^4} \right) \text{ in psi}$$

where :

- \bar{Q} = 110 percent of rated torque, in-lb
- D = Outside diameter of shaft, in
- d = Inside diameter of shaft, in

RPM	110 % Torque in-lbs	Tail Shaft			Tube Shaft			Line Shaft		
		D	d	S_s	D	d	S_s	D	d	S_s
80	1.146×10^5	27.5	9	2842	25.25	9	3689	21.125	9	6409
90	1.019×10^6	26.5	9	2573	24.25	9	3377	20.375	9	5807

Ship Vibration Design Guide

The compressive stress due to thrust is:

$$S_c = \frac{1.273 T}{D^2 - d^2} \text{ in psi}$$

where:

$$T = \text{Rated Thrust}$$

RPM	S _c , psi		
	Tail Shaft	Tube Shaft	Line Shaft
80	304	368	561
90	330	404	613

The steady resultant stress, S_{SR}, at full power, is:

$$S_{SR} = \sqrt{S_c^2 + (2S_s)^2}$$

RPM	S _{SR} , psi		
	Tail Shaft	Tube Shaft	Line Shaft
80	5692	7387	12,830
90	5156	6766	11,630

9.2 Alternating Stress

The bending moment in the tail shaft, M_g, due to propeller overhang is:

$$M_g = W_p L_p \text{ in lb}$$

where:

$$W_p = \text{Weight of Propeller, lbs}$$

$$L_p = \text{Distance from } C_p \text{ of Propeller to Center of Aft Strut Bearing} \\ \text{(assumed to be 66.5 ins)}$$

For the four cases studied, this is:

RPM	Blades	W _p	M _g
80	4	94,100	6.258 x 10 ⁶
	5	95,200	6.331 x 10 ⁶
90	4	87,200	5.799 x 10 ⁶
	5	88,100	5.859 x 10 ⁶

Appendix 5-A - Example Problem

This is doubled for off-center thrust and the bending moment is found from:

$$S_B = \frac{M_P D}{2I}$$

where :

- S_B = Alternating Bending Stress, psi
- M_P = $2 M_g$ = Total Bending Moment on Tail Shaft, in-lbs
- D = Outside diameter of shaft, in
- I = Shaft Moment of Inertia About the Diameter = $D^4/64$, in⁴

For the four cases studied:

RPM	Blades	D	S _B
80	4	27.5	6201
	5	27.5	6274
90	4	26.5	6434
	5	26.5	6500

These are all in excess of the 6,00 psi limit suggested by DDS 4301 [3]. However, the assumed overhang may be too large. Also, the assumption regarding off-center thrust should be evaluated for this ship if wake survey data becomes available.

The bending moments in the two longest shaft spans were calculated with the formula:

$$S_B = \frac{M_v C}{I}$$

where:

$$M_v = \frac{WL^2}{12}$$

- S_B = Bending Stress in Span, psi
- M_v = Bending Moment in Span, in-lb
- I = Shaft Moment of Inertia About the Diameter = $D^4/64$, in⁴
- W = Shaft Weight per Inch = w/g lb-sec² / in²
- L = Length of Span

Ship Vibration Design Guide

For the two shaft sizes:

RPM	Tube Shaft				Line Shaft			
	c	L	M_t	S_B	c	L	M_t	S_B
80	25.25	438	1.978 x 10 ⁶	1272	21.125	244	0.4028 x 10 ⁶	450
90	24.25	438	1.802 x 10 ⁶	1312	20.375	244	0.3685 x 10 ⁶	462

The torsional alternating stresses were found in Section 7.2, Torsional Response, and are repeated here:

RPM	Blades	Torsional Alternating Stress, S_S					
		Resonance			Full Power		
		Tall	Tube	Line	Tall	Tube	Line
80	4	602	781	1357	302	391	680
	5	481	624	1084	167	217	377
90	4	413	526	933	153	195	346
	5	327	416	739	88	112	200

Arranging the bending stresses in a similar table gives the same stresses for both resonant and full power speeds:

RPM	Blades	Bending Alternating Stress, S_B		
		Tall	Tube	Line
80	4	6201	1272	450
	5	6274	1272	450
90	4	6434	1312	462
	5	6500	1312	462

The resultant alternating stress, S_{alt} , is:

$$S_{alt} = \sqrt{S_D^2 + (2S_S)^2}$$

RPM	Blades	Resultant Alternating Stress, S_{alt}					
		Resonance			Full Power		
		Tall	Tube	Line	Tall	Tube	Line
80	4	6317	2014	2751	6230	1493	1433
	5	6347	1782	2214	6283	1344	878
90	4	6487	1682	1922	6441	1369	832
	5	6533	1554	1549	6502	1331	611

Appendix 5-A - Example Problem

To find the factors of safety at the torsional resonance, the steady resultant stress for that speed must be found as well as the steady resultant at full power. Since both the torque and thrust vary as the square of RPM, the steady resultant must also. Therefore:

$$S_{SR (Resonance)} = \left(\frac{\text{Torsional Natural Frequency}}{\text{Full Power Blade Rate}} \right)^2 \times S_{SR (FullPower)}$$

The table for S_{SR} becomes:

RPM	Blades	Steady Resultant Stress, S_B					
		Resonance			Full Power		
		Tall	Tube	Line	Tall	Tube	Line
80	4	1719	2231	3875	5692	7387	12,830
	5	1104	1433	2489	5692	7387	12,830
90	4	1237	1624	2791	5156	6766	11,630
	5	794	1042	1791	5156	6766	11,630

The factors of safety can then be found from:

$$\frac{S_{alt}}{F.L.} + \frac{S_{SR}}{Y.P.} = \frac{1}{F.S.}$$

where:

- $F.L.$ = Fatigue Limit of Shaft, Assumed 27,000 psi
- $Y.P.$ = Yield Point of Shaft, Assumed 30,000 psi
- $F.S.$ = Factor of Safety

The results are as follows:

RPM	Blades	Factor of Safety					
		Torsional Resonance			Full Power		
		Tall	Tube	Line	Tall	Tube	Line
80	4	3.43	6.71	4.32	2.38	3.31	2.08
	5	3.68	8.79	6.06	2.37	3.38	2.17
90	4	3.55	8.59	6.09	2.44	3.62	2.39
	5	3.73	10.84	8.54	2.42	3.64	2.44

The smallest factor of safety in the waterborne shafting is 2.37 compared to the required 2.00. The smallest factor in the inboard shafting is 2.08 compared to the required 1.75. Therefore, this design is considered quite satisfactory when judged by Navy requirements. A more refined evaluation should be made in the Phase II design study.

CONCLUSIONS

The first part of this study [1] recommended the use of the five-bladed propeller and 90 RPM as the rated operating condition, subject to confirmation by the analysis of the longitudinal and torsional vibration characteristics of the propulsion system. These analyses, as presented in this report, indicate that the longitudinal natural frequency of the propulsion shafting system coincides with propeller blade frequency at 133 percent to 181 percent of rated RPM, depending on the number of blades (four or five) and the RPM (80 to 90). The higher RPM and number of blades brings the critical speed closer to the operating speed and results in a higher dynamic magnification. This is also offset in part by the lower propeller forces generated. The resulting full power response, in turns, is about the same for all cases studied and ranges from 50 percent to 57 percent alternating thrust at the thrust bearing compared to the specified limit of 50 percent, including all correction factors.

The specifications also require the calculations to be made for 120 percent of rated RPM. Because this is significantly closer to the resonant speed, it causes the specified limits of vibratory thrust to be exceeded in all cases studied. It is felt that this requirement is too restrictive and that the increase in input forces by a factor of 3 in the 90 percent to 100 percent RPM range may be reduced if the efforts to minimize the input forces proposed in the earlier NKF report [1] are implemented.

It is also important to note that while the limitation of alternating thrust specified in MIL-STD-167 was invoked, no restriction is imposed on gear tooth loadings. The allowable alternating thrust and resulting motion of the bull gear can readily produce excessive gear tooth stresses and should be restricted, not to the limits specified in MIL-STD-167, but to the limits specified by the reduction gear manufacturer. Experience has indicated that gear tooth loading is most critical.

The fundamental torsional critical speed was found to be from 39 percent to 55 percent of rated speed, depending on the number of blades and rated speed. To minimize the exciting forces, the preferred combination of five blades and 90 RPM keeps the fundamental torsional mode low, at 39 percent of rated RPM, and the fundamental longitudinal mode at 133 percent of rated RPM. The torsional alternating stresses at all speeds are low and satisfy the ABS requirements for propulsion shaft stresses.

The alternating torque at resonance falls between 67 percent and 96 percent of the steady torque during turns and is estimated at approximately 160 percent in the shafting between the engine and the reduction gear at the fundamental critical of 35 RPM in the simplified system studied for the five-bladed propeller operating at 90 RPM. Although MIL-STD-167 was not invoked in the T-AO 187 specifications, the effect of torsional vibration on the system components, other than the propulsion shafting, is of major concern.

A second torsional mode occurs in the vicinity of 5.1 Hz, which is close to the full power rated RPM (76 RPM with a four-bladed propeller and 61 RPM with a five-bladed propeller). While this frequency is less accurately determined in the simplified analysis conducted, the presence

of excessive vibratory torque at the reduction gears is a distinct possibility and again emphasizes the necessity of limiting vibratory torques and gear tooth stresses.

The final selection of the optimum number of propeller blades and operating RPM must still be confirmed by the detailed analyses to be carried out in the Phase II design. It is concluded, however, that the five blades and 90 RPM combination would be best if modifications to the correction factors presently specified are adjusted to the operating conditions, and a better estimate of propeller forces preferably based on model studies and utilizing the necessary limitations on reduction gear vibratory stresses is made.

All natural frequencies of lateral vibration of the propulsion shafting system were found to be above 483 CPM when examined by three different methods and should provide no problems in this area. Preliminary checks on the bearing spacing and general arrangement indicate the proposed configuration is adequate although suggestions for improvement are given.

In this preliminary analysis, in which the propeller overhang was estimated, the limit of $\pm 6,000$ pounds alternating bending stress, indicated by Navy specifications [3], was exceeded by less than 10 percent. Although this requirement is not included in the T-AO 187 specifications, the Navy specifications were used for evaluation purposes. This may not be the case, however, when final details for the propeller shaft system are completed and a better estimate of off-center thrust is obtained from model studies or calculated from wake data.

It was also determined that the shafting system, designed to ABS requirements, would satisfy the factors of safety called for by the Navy specification [3].

RECOMMENDATIONS

The recommendations presented herein support the recommendations previously given in the companion study on the Propeller Hull Configuration (4.4.2.7). However, confirmation of the preferred combination of five-bladed propellers and 90 RPM is still lacking due to the specified correction factors (which are considered overly conservative), the requirement for 120 percent rated speed, the lack of complete definition of system component details, and the omission of adequate specifications for gear loadings. The revised list of recommendations includes:

- Model studies presently prescribed in the specifications should be expanded to permit the optimization of the stern underwater details.
- Consideration should be given to reducing the skeg size, starting at Frame 110 rather than 117, to improve the inflow to the propeller.
- To provide a more accurate evaluation of stern details and to obtain estimates of total propeller forces entering the hull and machinery systems, it is recommended that self-propelled model studies be conducted at the vacuum tank at the Netherlands Ship Model Basin (N.S.M.B.).

Ship Vibration Design Guide

- Cavitation/hull pressure studies at SSPA should be conducted after optimization of the underwater design details and evaluation of the total propeller forces obtained at N.S.M.B.
- Stress limits on important elements of the propulsion system should be established by the manufacturers of major components such as reduction gears, clutches, couplings, etc.
- MIL-STD-167 specifications for allowable vibratory torque and stress limits should be invoked for torsional and longitudinal vibration of the propulsion system.
- Correction factors for longitudinal and torsional vibratory forces on the propulsion system should be modified to reflect propeller forces determined by model studies and operating conditions required for the T-AO 187.
- Detailed vibration analyses of the hull, aft superstructure, and propulsion system should be carried out based on input data derived from model studies, appropriate correction factors, and stress limits provided by manufacturers and Navy specifications.
- Finite element analysis should be carried out on the thrust foundation to determine actual stiffness values and to determine how to increase the stiffness, if feasible.
- Unless the analysis still indicates potential problems, a five-bladed propeller, operating at 90 RPM, should be considered preferable.

REFERENCES

1. NKF Engineering Associates, Inc., "T-AO 187 Baseline Review (Par. 4.4.2.7), An Evaluation of the Proposed Propeller Hull Configuration," Report No. 8213-001/1, May 1982.
2. "ABS Rules for Building and Classing Steel Vessels," 1980.
3. Department of the Navy Design Data Sheet DDS 4301, "Propulsion Shafting," 1 January, 1960.
4. Bird-Johnson Company letter dated April 16, 1982, Subject: "Bird -Johnson Co./KaMeWa Controllable Pitch Propeller for T-AO 187."
5. Zaloumis, A., and G. Antonides, "Recent Developments in Longitudinal Vibration of Surface Ship Propulsion Systems," NSRDC Report 3358, September 1970.
6. McGoldrick, R.T., "Ship Vibration," DTMB Report 1451, December 1960.
7. Nestorides, E.J., "A Handbook on Torsional Vibration," B.I.C.E.R.A, Cambridge, 1958.
8. MIL-STD-167-2 (Ships), "Military Standard Mechanical Vibrations of Shipboard Equipment," 1 May, 1974.

APPENDIX 5-B

M.A.N. DIESEL ENGINES

Engine Power Range and Fuel Consumption

Comments on Power and SFOC Tables

The following pages contain data regarding the engine power, speed and specific fuel oil consumption of the MC engines.

Engine power is specified in both BHP and kW, in round numbers, for each cylinder number and in four layout points:

L_1 designates nominal maximum continuous rating (= nominal MCR), at 100% engine power and 100% engine speed.

L_2 , L_3 and L_4 designate layout points at the other three corners of the layout area, chosen for easy reference. As described in detail in the next section "Layout, SFOC at Part Load and Load Diagram", any point within the layout area may be chosen as MCR and the engine may, if so desired, be delivered optimized for this specified MCR rating. The four reference points L_1 , L_2 , L_3 and L_4 are specified as stated in the table and shown in Fig. 2.1:

Designation	Mean effective pressure	Engine speed
L_1	100%	100%
L_2	80%	100%
L_3	100%	75%
L_4	80%	75%

On the L35MC/MCE engines, the r/min at L_1 and L_4 is kept at 82%, as previously.

Overload rating (OR) corresponds to 110% of the power at MCR, and may be permitted for a limited period of one hour every 12 hours. OR corresponds to 106.7% mean effective pressure and 103.3% engine speed, referring to MCR as 100%.

The engine power figures given in the tables remain valid up to tropical conditions at sea level, i.e.:

Tropical Conditions:

Blower inlet temperature 45°C
 Blower inlet pressure 1000 mbar
 Charge air coolant temperature 34°C

Specific fuel oil consumption values refer to brake power, and the following reference conditions:

Reference Conditions (ISO Ambient):

Blower inlet temperature 27°C
 Blower inlet pressure 1000 mbar
 Charge air coolant temperature 27°C

Fuel oil lower calorific value 42707 kJ/kg
 (10200 kcal/kg)

Although the engine will develop the power specified up to tropical ambient conditions, specific fuel oil consumption varies with ambient conditions and

fuel oil lower calorific value. For calculation of these changes, see the section entitled "Layout, SFOC at Part Load and Load Diagram".

Except for the three smallest engine types, the L42, the L35 and the S26, the specific fuel oil consumption figures are stated for engines without TCS (Turbo Compound System), as well as for engines with TCS, the design particulars of which are dealt with in the section on "Turbocharger Types and Turbo Compound Systems". The use of TCS can reduce fuel consumption substantially in the normal power range of the engine, as will appear from the tables.

SFOC Guarantee

The Specific Fuel Oil Consumption (SFOC) is guaranteed for one engine load (power-speed combination), this being the one in which the engine is optimized. The guarantee is given with a margin of 3%, and the optimized point is chosen within the layout area on the selected propeller curve. The SFOC guarantee refers to the above-mentioned reference conditions (ISO ambient and a lower calorific value of 42707 kJ/kg = 10200 kcal/kg).

Lubricating Oil Data

The cylinder oil consumption figures stated in the tables are valid under normal conditions. During running-in periods and under special conditions, feed rates of up to 1.5 times the stated values should be used.

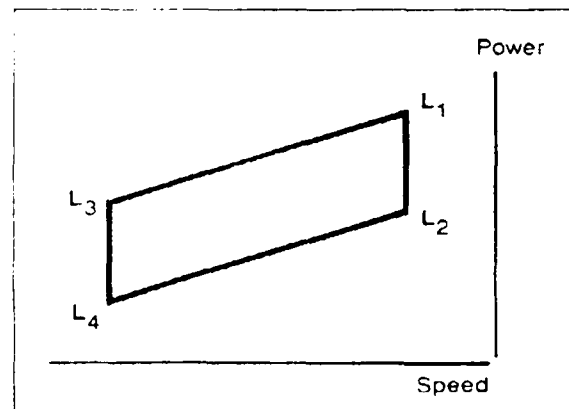

Fig. 2.1
Layout diagram

Ship Vibration Design Guide

Power, Speed and SFOC

		K90MC				K90MCE			
		Stroke 2550		Bore 900		Stroke 2550		Bore 900	
		L ₁	L ₂	L ₃	L ₄	L ₁	L ₂	L ₃	L ₄
Speed	r/min	90	90	67	67	90	90	67	67
Cyl.no. Power									
4	kW	15760	12640	11720	9400	12640	10120	9400	7520
	BHP	21440	17200	15960	12800	17200	13760	12800	10240
5	kW	19700	16800	14650	11750	18800	12650	11750	9400
	BHP	26800	21500	19950	16000	21500	17200	16000	12800
6	kW	23640	19960	17560	14100	18960	15180	14100	11290
	BHP	32160	25800	23940	19200	25800	20840	19200	15360
7	kW	27380	22120	20510	16450	22120	17710	16450	13190
	BHP	37320	30100	27930	22400	30100	24080	22400	17920
8	kW	31620	26260	23440	18900	26260	20340	18900	15040
	BHP	42880	34400	31920	25800	34400	27520	25800	20480
9	kW	35480	28440	26370	21150	28440	22770	21150	16920
	BHP	48240	38700	35910	28800	38700	30960	28800	23040
10	kW	39400	31800	29300	23500	31800	25300	23500	18800
	BHP	53600	43000	39900	32000	43000	34400	32000	25600
11	kW	43340	34780	32230	25850	34780	27830	25850	20880
	BHP	58960	47300	43890	35200	47300	37840	35200	28160
12	kW	47280	37920	35180	28200	37920	30360	28200	22560
	BHP	64320	51600	47880	38400	51600	41280	38400	30720
SFOC g/BHP at MCR									
With TCS		121	118	121	118	118	115	118	118
Without TCS		126	121	126	121	121	117	121	117
SFOC g/BHP minimum at part load									
With TCS		120	117	120	117	117	114	117	114
Without TCS		124	119	124	119	119	116	119	116
Lube Oil Consumption		10-13 kg/cyl/24 h							
Cylinder Oil Consumption		0.6 g/BHP							

		K90MC-2			
		Stroke 2300		Bore 900	
		L ₁	L ₂	L ₃	L ₄
Speed	r/min	100	100	75	75
Cyl.no. Power					
4	kW	15760	12640	11720	9400
	BHP	21440	17200	15960	12800
5	kW	19700	16800	14650	11750
	BHP	26800	21500	19950	16000
6	kW	23640	19960	17560	14100
	BHP	32160	25800	23940	19200
7	kW	27380	22120	20510	16450
	BHP	37320	30100	27930	22400
8	kW	31620	26260	23440	18900
	BHP	42880	34400	31920	25800
9	kW	35480	28440	26370	21150
	BHP	48240	38700	35910	28800
10	kW	39400	31800	29300	23500
	BHP	53600	43000	39900	32000
11	kW	43340	34780	32230	25850
	BHP	58960	47300	43890	35200
12	kW	47280	37920	35180	28200
	BHP	64320	51600	47880	38400
SFOC g/BHP at MCR					
With TCS		122	118	122	118
Without TCS		127	122	127	122
SFOC g/BHP minimum at part load					
With TCS		121	118	121	118
Without TCS		125	120	125	120
Lube Oil Consumption		10-13 kg/cyl/24 h			
Cylinder Oil Consumption		0.6 g/BHP			

		L90MC				L90MCE			
		Stroke 2916		Bore 900		Stroke 2916		Bore 900	
		L ₁	L ₂	L ₃	L ₄	L ₁	L ₂	L ₃	L ₄
Speed	r/min	78	78	56	56	78	78	56	56
Cyl.no. Power									
4	kW	16640	12660	11640	9320	12560	10040	9320	7440
	BHP	21240	17040	15830	12680	17040	13640	12680	10160
5	kW	19860	15700	14560	11650	15700	12650	11650	9300
	BHP	26950	21300	19790	15850	21300	17050	15850	12700
6	kW	23480	18840	17460	13920	18840	14960	13920	11180
	BHP	31860	25560	23700	19020	25560	20460	19020	15240
7	kW	27370	21980	20370	16310	21980	17570	16310	13020
	BHP	37170	29820	27850	22190	29820	23870	22190	17780
8	kW	31280	25120	23280	18640	25120	20080	18640	14880
	BHP	42460	34080	31800	25360	34080	27280	25360	20320
9	kW	35180	28280	26180	20970	28280	22590	20970	16740
	BHP	47780	38440	35550	28530	38440	30690	28530	22980
10	kW	39100	31400	29100	23300	31400	25100	23300	18680
	BHP	53100	42600	39500	31700	42600	34100	31700	25400
11	kW	43010	34540	32010	25630	34540	27610	25630	20480
	BHP	58410	46860	43450	34870	46860	37510	34870	27940
12	kW	46920	37880	34920	27980	37880	30120	27980	22320
	BHP	63720	51200	47400	38040	51200	40920	38040	30480
SFOC g/BHP at MCR									
With TCS		121	118	121	118	118	115	118	118
Without TCS		126	121	126	121	121	117	121	117
SFOC g/BHP minimum at part load									
With TCS		120	117	120	117	117	114	117	114
Without TCS		124	119	124	119	119	116	119	116
Lube Oil Consumption		9-13 kg/cyl/24 h							
Cylinder Oil Consumption		0.6 g/BHP							

		S80MC				S80MCE			
		Stroke 3056		Bore 800		Stroke 3056		Bore 800	
		L ₁	L ₂	L ₃	L ₄	L ₁	L ₂	L ₃	L ₄
Speed	r/min	77	77	57	57	77	77	57	57
Cyl.no. Power									
4	kW	13400	10720	9920	7920	10720	8800	7920	6380
	BHP	18240	14600	13480	10800	14600	11960	10800	8640
5	kW	16780	13400	12400	9800	13400	10750	9800	7880
	BHP	22800	18250	16850	13500	18250	14600	13500	10800
6	kW	20100	16080	14880	11880	16080	12900	11880	9540
	BHP	27360	21900	20220	16200	21900	17520	16200	12960
7	kW	23480	18780	17380	13880	18780	15050	13880	11130
	BHP	31920	25550	23590	18900	25550	20440	18900	15120
8	kW	26800	21440	19840	15840	21440	17300	15840	12720
	BHP	36460	29200	26960	21600	29200	23360	21600	17280
9	kW	30180	24120	22320	17820	24120	19360	17820	14310
	BHP	41040	32850	30330	24300	32850	26280	24300	19440
10	kW	33500	26800	24800	19800	26800	21800	19800	15900
	BHP	45600	36500	33700	27000	36500	29200	27000	21800
11	kW	36850	29480	27280	21780	29480	23860	21780	17480
	BHP	50160	40150	37070	29700	40150	32120	29700	23780
12	kW	40200	32160	29760	23780	32160	26080	23780	19080
	BHP	54720	43800	40440	32400	43800	36040	32400	25920
SFOC g/BHP at MCR									
With TCS		121	118	121	118	118	115	118	118
Without TCS		126	121	126	121	121	117	121	117
SFOC g/BHP minimum at part load									
With TCS		120	117	120	117	117	114	117	114
Without TCS		124	119	124	119	119	116	119	116
Lube Oil Consumption		9-11 kg/cyl/24 h							
Cylinder Oil Consumption		0.6 g/BHP							

Power, Speed and SFOC

Speed (rpm)	K80MC				K80MCE				
	Stroke 2300		Bore 800		Stroke 2300		Bore 800		
	L ₁	L ₂	L ₃	L ₄	L ₁	L ₂	L ₃	L ₄	
100	100	75	75	100	100	75	75		
Cyl.no. Power									
4	kW	12480	10800	9360	7520	10000	8000	7380	6000
	BHP	18960	13640	12720	10200	13640	10880	10200	8180
5	kW	16800	13800	11700	8400	12600	10000	8400	7800
	BHP	21200	17060	16800	12750	17060	13600	12750	10200
6	kW	18720	16080	14040	11280	18000	12000	11280	9000
	BHP	26440	20480	19080	15300	20480	16320	15300	12240
7	kW	21840	17500	16380	13160	17800	14000	12180	10600
	BHP	29680	23870	22280	17850	23870	19040	17850	14280
8	kW	24960	20000	18720	15040	20000	16000	16040	12000
	BHP	33920	27280	26440	20400	27280	21760	20400	16320
9	kW	28080	22800	21080	16920	22500	18000	18920	13800
	BHP	38160	30880	28280	22950	30880	24480	22950	18360
10	kW	31200	25080	23400	18800	26000	20000	18800	13800
	BHP	42400	34100	31800	25600	34100	27200	25600	20400
11	kW	34320	27880	25740	20680	27500	22000	20680	16800
	BHP	46640	37510	34980	28050	37510	29200	28050	22440
12	kW	37440	30080	28080	22560	30000	24000	22560	18000
	BHP	50800	40920	38160	30800	40920	32640	30800	24480
SFOC g/BHP at MCR									
With TCS	122	119	122	119	119	118	119	116	
Without TCS	127	122	127	122	122	118	122	118	
SFOC g/BHP minimum at part load									
With TCS	121	118	121	118	118	116	118	115	
Without TCS	125	120	125	120	120	117	120	117	
Lube Oil Consumption	8-10 kg/cyl/24 h								
Cylinder Oil Consumption	0.6 g/BHP/h								

Speed (rpm)	L80MC				L80MCE				
	Stroke 2592		Bore 800		Stroke 2592		Bore 800		
	L ₁	L ₂	L ₃	L ₄	L ₁	L ₂	L ₃	L ₄	
88	88	66	66	88	88	66	66		
Cyl.no. Power									
4	kW	12400	9920	8280	7440	9920	7980	7440	6080
	BHP	16840	13520	12840	10120	13520	10800	10120	8120
6	kW	18800	13400	11800	9300	12400	9980	9300	7480
	BHP	21060	18800	16800	12650	18800	13800	12650	10180
6	kW	18800	14880	13920	11180	14880	11940	11180	8940
	BHP	25260	20280	18960	16180	20280	16200	16180	12180
7	kW	21700	17380	16240	13020	17380	13830	13020	10480
	BHP	29470	23660	22200	17710	23660	18800	17710	14210
8	kW	24800	19840	18880	14880	19840	16820	14880	11920
	BHP	30880	27040	25280	20240	27040	21800	20240	16240
9	kW	27800	22320	20880	16740	22320	17810	16740	13410
	BHP	37800	30420	28440	22770	30420	24300	22770	18270
10	kW	31800	24800	23200	18800	24800	19800	18800	14900
	BHP	42100	33800	31600	25300	33800	27000	25300	20300
11	kW	34100	27280	25300	20480	27280	21980	20480	16380
	BHP	46310	37180	34760	27830	37180	29700	27830	22330
12	kW	37200	28780	27840	22320	28780	23880	22320	17880
	BHP	50520	40560	37820	30360	40560	32400	30360	24360
SFOC g/BHP at MCR									
With TCS	122	119	122	119	119	118	119	116	
Without TCS	127	122	127	122	122	118	122	118	
SFOC g/BHP minimum at part load									
With TCS	121	118	121	118	118	116	118	115	
Without TCS	125	120	125	120	120	117	120	117	
Lube Oil Consumption	8-10 kg/cyl/24 h								
Cylinder Oil Consumption	0.6 g/BHP/h								

Speed (rpm)	S70MC				S70MCE				
	Stroke 2674		Bore 700		Stroke 2674		Bore 700		
	L ₁	L ₂	L ₃	L ₄	L ₁	L ₂	L ₃	L ₄	
88	88	66	66	88	88	66	66		
Cyl.no. Power									
4	kW	10280	8200	7880	6160	8200	6500	6160	4920
	BHP	13960	11180	10480	8360	11180	8960	8360	6720
5	kW	12880	10280	9800	7700	10250	8250	7700	6150
	BHP	17450	13950	13300	10450	13950	11200	10450	8400
6	kW	15480	12300	11520	9240	12300	9900	9240	7360
	BHP	20940	16740	15720	12540	16740	13440	12540	10080
7	kW	17900	14380	13440	10780	14350	11550	10780	8610
	BHP	24430	19530	18340	14630	19530	15680	14630	11780
8	kW	20560	16400	15360	12320	16400	11200	12320	9840
	BHP	27920	22300	21060	16720	22300	15200	16720	13440
SFOC g/BHP at MCR									
With TCS	121	118	121	118	118	115	118	115	
Without TCS	126	121	126	121	121	117	121	117	
SFOC g/BHP minimum at part load									
With TCS	120	117	120	117	117	114	117	114	
Without TCS	124	119	124	119	119	116	119	116	
Lube Oil Consumption	7.9 kg/cyl/24 h								
Cylinder Oil Consumption	0.6 g/BHP/h								

Speed (rpm)	L70MC				L70MCE				
	Stroke 2268		Bore 700		Stroke 2268		Bore 700		
	L ₁	L ₂	L ₃	L ₄	L ₁	L ₂	L ₃	L ₄	
100	100	75	75	100	100	75	75		
Cyl.no. Power									
4	kW	9440	7580	7080	5680	7580	6040	6080	4520
	BHP	12800	10280	9500	7720	10280	8240	7720	6160
5	kW	11800	8480	8850	7100	8480	7350	7100	5650
	BHP	16000	11550	12000	9650	12000	10300	9650	7700
6	kW	14180	11340	10620	8620	11340	9860	9620	7680
	BHP	19200	15420	14400	11580	15420	13360	11580	9240
7	kW	16520	13230	12390	9840	13230	10670	9940	7910
	BHP	22400	17990	16800	13510	17990	14420	13510	10780
8	kW	18880	15120	14180	11380	15120	12080	11380	8040
	BHP	25600	20540	19200	15440	20540	16440	15440	11200
SFOC g/BHP at MCR									
With TCS	122	119	122	119	119	118	119	116	
Without TCS	127	122	127	122	122	118	122	118	
SFOC g/BHP minimum at part load									
With TCS	121	118	121	118	118	116	118	115	
Without TCS	126	120	126	120	120	117	120	117	
Lube Oil Consumption	6.8 kg/cyl/24 h								
Cylinder Oil Consumption	0.5 g/BHP/h								

Ship Vibration Design Guide

External Forces and Moments in Layout Point L₁

K90MC and K90MCE

No. of Cyl.	4	5	6	7	8	9	10	11	12
Firing order	1-3-2-4	1-4-3-2-5	1-5-3-4-2-6	1-7-2-5-4-3-6	1-8-3-4-7-2-5-6	1-9-2-7-3-6-5-4-8	1- 9-4-6-3-10-2-7-5- 8	1-9- 6-4-10-2- 8-5-7-3-11	1-12-5-7-3-11-4-9-2-10-6-8

External Forces in kN

	0	0	0	0	0	0	0	0	0
--	---	---	---	---	---	---	---	---	---

External Moments in kNm

Order:									
1st a	2293 b	728	0	1102	189	1145	1456	948	0
2nd	4879 c	6074 c	4225 c	786	0	440	0	801	0

a, b and c see text

Guide Force H-moments in kNm

MC									
Order:									
1 x No. of cyl.	2292	2228	1659	1273	895	528	362	276	193
2 x No. of cyl.	448	181	96						
3 x No. of cyl.	64								

MCE									
Order:									
1 x No. of cyl.	2065	2111	1692	1366	1001	684	503	344	236
2 x No. of cyl.	500	251	118						
3 x No. of cyl.	79								

Guide Force X-moments in kNm

MC									
Order:									
1st	897	285	0	431	74	448	570	371	0
2nd	140	174	121	22	0	13	0	23	0
3rd	160	562	1016	1343	1699	402	1123	153	1436
4th	0	117	906	3113	1046	4890	0	4020	1812
5th	288	0	0	128	3064	3803	6036	4698	0
6th	505	57	0	86	0	450	0	2916	5254
7th	117	413	0	39	10	30	827	1276	0
8th	0	254	177	35	0	36	0	69	354
9th	38	12	241	17	3	13	24	18	341
10th	66	0	57	197	0	12	0	10	0
11th	16	5	0	136	172	4	10	5	0
12th	0	37	0	5	29	26	0	4	0

MCE									
Order:									
1st	760	241	0	365	63	379	482	314	0
2nd	496	617	430	78	0	45	0	81	0
3rd	86	302	547	723	915	216	605	82	773
4th	0	106	816	2806	943	4407	0	3623	1633
5th	273	0	0	121	2903	3604	5721	4453	0
6th	515	58	0	87	0	458	0	2974	5357
7th	126	444	0	42	10	32	887	1369	0
8th	0	284	198	39	0	40	0	77	396
9th	49	16	312	22	4	16	31	23	442
10th	92	0	79	273	0	16	0	13	0
11th	20	6	0	170	215	5	13	7	0
12th	0	45	0	6	36	32	0	5	0

External Forces and Moments in Layout Point L₁

L90MC and L90MCE

No. of Cyl.	4	5	6	7	8	9	10	11	12
Firing order	1-3-2-4	1-4-3-2-5	1-5-3-4-2-6	1-7-2-5-4-3-6	1-8-3-4-7-2-5-6	1-9-2-7-3-6-5-4-8	1-9-4-6-3-10-2-7-5-8	1-9-6-4-10-2-8-5-7-3-11	1-12-5-7-3-11-4-9-2-10-6-8

External Forces in kN

	0	0	0	0	0	0	0	0	0
--	---	---	---	---	---	---	---	---	---

External Moments in kNm

Order:									
1st a	1956 b	621	0	940	162	976	1242	808	0
2nd	4812 c	5990 c	4167 c	755	0	434	0	790	0

a, b and c see text

Guide Force H-moments in kNm

MC Order:									
1 x No. of cyl.	2582	2550	1898	1455	1022	601	411	313	219
2 x No. of cyl.	511	205	110						
3 x No. of cyl.	73								

MCE Order:									
1 x No. of cyl.	2326	2420	1939	1565	1145	782	573	391	268
2 x No. of cyl.	573	287	134						
3 x No. of cyl.	89								

Guide Force X-moments in kNm

MC Order:									
1st	1023	325	0	492	84	511	650	423	0
2nd	243	303	211	38	0	22	0	40	0
3rd	194	683	1234	1632	2065	488	1365	186	1745
4th	0	132	1021	3507	1178	5510	0	4529	2041
5th	329	0	0	146	3507	4353	6909	5578	0
6th	578	65	0	98	0	514	0	3336	6009
7th	134	472	0	44	11	34	945	1458	0
8th	0	290	202	40	0	41	0	79	404
9th	43	14	275	19	4	14	27	20	388
10th	75	0	65	223	0	13	0	11	0
11th	18	6	0	155	196	5	12	6	0
12th	0	41	0	5	33	30	0	5	0

MCE Order:									
1st	867	275	0	417	72	433	551	358	0
2nd	181	225	157	28	0	16	0	30	0
3rd	110	386	697	922	1167	276	771	105	988
4th	0	119	919	3160	1062	4964	0	4080	1839
5th	312	0	0	139	3328	4132	6558	5104	0
6th	580	66	0	100	0	525	0	3407	6138
7th	144	508	0	48	12	37	1016	1568	0
8th	0	325	226	44	0	46	0	89	453
9th	56	18	357	25	5	19	36	26	504
10th	105	0	91	312	0	18	0	15	0
11th	23	7	0	193	244	6	15	8	0
12th	0	51	0	6	41	36	0	6	0

External Forces and Moments in Layout Point L₁

S80MC and S80MCE

No. of Cyl.	4	5	6	7	8	9	10	11	12
Firing order	1-3-2-4	1-4-3-2-5	1-5-3-4-2-6	1-7-2-5-4-3-6	1-8-3-4-7-2-5-6	1-6-7-3-5-8-2-4-9	1- 9-4-6-3-10-2-7-5- 8	1-9- 6-4-10-2- 8-5-7-3-11	1-12-5-7-3-11-4-9-2-10-6-8

External Forces in kN

	0	0	0	0	0	0	0	0	0
--	---	---	---	---	---	---	---	---	---

External Moments in kNm

Order:									
1st a	1282 b	407	0	242	513	835	814	541	0
2nd	3327 c	4141 c	2881 c	836	0	940	0	551	0

a, b and c: see text

Guide Force H-moments in kNm

MC									
Order:									
1 x No. of cyl.	2262	2207	1630	1230	843	484	325	279	245
2 x No. of cyl.	421	163	122						
3 x No. of cyl.	82								
MCE									
Order:									
1 x No. of cyl.	2045	2084	1650	1308	931	625	443	286	191
2 x No. of cyl.	465	222	96						
3 x No. of cyl.	64								

Guide Force X-moments in kNm

MC									
Order:									
1st	791	257	0	150	502	516	503	334	0
2nd	402	501	348	101	0	114	0	67	0
3rd	177	623	1126	1232	1579	2250	1247	172	1593
4th	0	103	796	2262	919	1146	0	3523	1592
5th	254	0	0	180	2263	895	5291	4120	0
6th	442	50	0	30	0	1985	0	2537	4571
7th	101	356	0	0	64	81	711	1095	0
8th	0	213	148	11	0	39	0	59	297
9th	31	10	197	22	20	29	20	14	278
10th	53	0	46	130	0	12	0	8	0
11th	15	5	0	101	130	12	9	5	0
12th	0	47	0	8	33	149	0	5	0
MCE									
Order:									
1st	675	214	0	128	428	440	429	285	0
2nd	127	153	107	31	0	35	0	20	0
3rd	115	405	731	800	1025	1461	809	112	1034
4th	0	93	720	2046	831	1275	0	3186	1440
5th	240	0	0	170	2137	845	4995	3891	0
6th	447	50	0	30	0	2009	0	2568	4627
7th	107	378	0	0	68	86	757	1165	0
8th	0	235	164	13	0	44	0	55	328
9th	40	13	254	28	25	38	25	19	359
10th	72	0	62	177	0	17	0	11	0
11th	15	5	0	104	133	12	9	5	0
12th	0	32	0	7	26	117	0	4	0

Ship Vibration Design Guide

External Forces and Moments in Layout Point L₁

K80MC and K80MCE									
No. of Cyl.	4	5	6	7	8	9	10	11	12
Firing order	1-3-2-4	1-4-3-2-5	1-5-3-4-2-6	1-7-2-5-4-3-6	1-8-2-6-4-5-3-7	1-6-7-3-5-8-2-4-9	1-9-4-6-3-10-2-7-5-8	1-9-6-4-10-2-8-5-7-3-11	1-12-5-7-3-11-4-9-2-10-6-8
External Forces in kN									
	0	0	0	0	0	0	0	0	0
External Moments in kNm									
Order:									
1st a	1587 b	504	0	300	503	1034	1008	669	0
2nd	3429 c	4269 c	2970 c	862	0	969	0	566	0
a, b and c. see text									
Guide Force H-moments in kNm									
MC									
Order:									
1 x No. of cyl.	1630	1588	1183	907	638	377	258	197	137
2 x No. of cyl.	319	129	69						
3 x No. of cyl.	46								
MCE									
Order:									
1 x No. of cyl.	1467	1503	1205	973	713	488	359	245	169
2 x No. of cyl.	357	179	84						
3 x No. of cyl.	56								
Guide Force X-moments in kNm									
MC									
Order:									
1st	839	203	0	121	203	417	406	270	0
2nd	75	93	65	19	0	21	0	12	0
3rd	114	401	724	792	508	1446	801	111	1024
4th	0	84	644	1831	2976	928	0	2851	1289
5th	205	0	0	146	914	723	4275	3329	0
6th	360	40	0	24	0	1617	0	2067	3724
7th	84	295	0	0	27	67	589	907	0
8th	0	181	126	10	0	34	0	50	252
9th	27	9	172	19	9	26	17	13	243
10th	47	0	41	116	0	11	0	7	0
11th	12	4	0	80	51	9	7	4	0
12th	0	26	0	5	84	94	0	3	0
MCE									
Order:									
1st	541	172	0	102	172	353	344	228	0
2nd	330	411	286	83	0	93	0	55	0
3rd	61	215	388	424	272	775	429	59	549
4th	0	75	580	1648	2678	835	0	2566	1160
5th	194	0	0	138	866	684	4048	3153	0
6th	357	41	0	25	0	1648	0	2106	3795
7th	0	316	0	0	28	72	632	973	0
8th	0	203	111	11	0	38	0	56	262
9th	30	11	223	25	11	33	22	16	315
10th	65	0	57	161	0	15	0	10	0
11th	14	5	0	100	64	12	9	5	0
12th	0	32	0	6	103	115	0	4	0

Appendix 5-B - Slow-Speed Diesel Data

External Forces and Moments in Layout Point L₁

L80MC and L80MCE									
No. of Cyl.	4	5	6	7	8	9	10	11	12
Firing order	1-3-2-4	1-4-3-2-5	1-5-3-4-2-6	1-7-2-5-4-3-6	1-8-2-6-4-5-3-7	1-6-7-3-5-8-2-4-9	1- 9-4-6-3-10-2-7-5- 8	1-9- 6-4-7-3-11	1-12-5-7-3-11-4-9-2-10-6-8
External Forces in kN									
	0	0	0	0	0	0	0	0	0
External Moments in kNm									
Order:									
1st a	1376 b	437	0	260	436	896	874	580	0
2nd	3384 c	4213 c	2931 c	851	0	956	0	560	0
a, b and c: see text									
Guide Force H-moments in kNm									
MC									
Order:									
1 x No. of cyl.	1814	1792	1333	1022	717	422	288	219	153
2 x No. of cyl.	359	144	77						
3 x No. of cyl.	51								
MCE									
Order:									
1 x No. of cyl.	1627	1695	1358	1097	804	550	404	276	190
2 x No. of cyl.	402	202	95						
3 x No. of cyl.	63								
Guide Force X-moments in kNm									
MC									
Order:									
1st	719	228	0	136	228	469	457	303	0
2nd	170	212	147	43	0	48	0	28	0
3rd	136	479	866	948	607	1730	859	132	1225
4th	0	83	717	2038	3312	1032	0	3174	1434
5th	231	0	0	164	1032	816	4824	3757	0
6th	406	46	0	27	0	1829	0	2330	4198
7th	94	332	0	0	30	75	663	1021	0
8th	0	204	142	11	0	38	0	56	283
9th	30	10	192	21	10	29	19	14	272
10th	53	0	45	129	0	12	0	8	0
11th	13	4	0	89	57	10	8	4	0
12th	0	29	0	6	93	105	0	3	0
MCE									
Order:									
1st	607	193	0	115	193	396	386	256	0
2nd	134	167	116	34	0	38	0	22	0
3rd	75	265	478	523	335	955	529	73	676
4th	0	83	643	1827	2970	926	0	2848	1286
5th	219	0	0	158	976	772	4563	3554	0
6th	413	46	0	28	0	1857	0	2374	4277
7th	101	356	0	0	32	81	712	1097	0
8th	0	228	159	12	0	42	0	63	318
9th	39	13	261	28	12	38	25	18	355
10th	74	0	64	182	0	17	0	11	0
11th	16	5	0	113	72	13	10	5	0
12th	0	36	0	7	116	130	0	4	0

SULZER RTA MARINE DIESEL ENGINES

Engine Data

Reference Conditions

ISO-CONDITIONS

Suction air temperature	27 °C
Charge air cooling water inlet temperature	27 °C
Total barometric pressure	1 bar = 750 mm Hg

ENVIRONMENTAL CONDITIONS specified by classification societies

Suction air temperature	45 °C
Charge air cooling water inlet temperature	32 °C (sea water)
Total barometric pressure	1 bar = 750 mm Hg

REMARKS

- Tropical conditions correspond to the limiting values for engine operation without restrictions, such as power reduction etc. The ancillary systems are therefore laid out for tropical conditions.
- Besides the ambient conditions, treatment of fuel oil and condition for cooling and lubricating systems also influence engine performance. The given engine data is therefore only valid if the respective requirements are observed.
- ISO-CONDITIONS According to ISO-International Standard 3046/1.
- ENVIRONMENTAL CONDITIONS Corresponds to the term TROPICAL CONDITIONS mentioned in this booklet.

Appendix 5-B - Slow-Speed Diesel Data

Engine Type	RTA 84 M				RTA 72				RTA 62				RTA 52				
Bore mm	840				720				620				520				
Stroke mm	2900				2500				2150				1800				
Ratings R 1 to R 4 are corner points of the field of admissible engine ratings	Engine Maximum Continuous Rating				Engine Maximum Continuous Rating				Engine Maximum Continuous Rating				Engine Maximum Continuous Rating				
	R 1	R 2	R 3	R 4	R 1	R 2	R 3	R 4	R 1	R 2	R 3	R 4	R 1	R 2	R 3	R 4	
Speed n	78	78	56	56	91	91	66	66	106	106	76	76	126	126	91	91	
Engine Power P																	
	kW/Cyl	3460	1900	2490	1900	2570	1410	1860	1410	1900	1050	1360	1050	1330	740	960	740
	BHP/Cyl	4700	2580	3380	2580	3500	1920	2530	1920	2580	1430	1850	1430	1810	1000	1300	1000
Specific Fuel Consumption *1) without Efficiency-Booster																	
	$\frac{g}{kW h}$	170	159	169	162	171	160	170	163	173	162	171	165	174	163	173	166
100 % P Tol. + 3 %																	
	$\frac{g}{BHP h}$	125	117	124	119	126	118	125	120	127	119	126	121	128	120	127	122
85 % P																	
	$\frac{g}{kW h}$	167	159	166	160	169	160	167	162	170	162	169	163	171	163	170	165
	$\frac{g}{BHP h}$	123	117	122	118	124	118	123	119	125	119	124	120	126	120	125	121
Specific Fuel Consumption with Efficiency-Booster																	
	$\frac{g}{kW h}$	165	156	163	158	166	158	165	159	167	159	166	160	169	160	167	162
100 % P Tol. + 3 %																	
	$\frac{g}{BHP h}$	121	115	120	116	122	116	121	117	123	117	122	118	124	118	123	119
85 % P																	
	$\frac{g}{kW h}$	163	156	162	156	165	158	163	158	166	159	165	158	167	160	166	160
	$\frac{g}{BHP h}$	120	115	119	115	121	116	120	116	122	117	121	117	123	118	122	118
Number of Cylinders *2)	4-10 and 12				4-8				4-8				4-8				

Remarks:

- * 1) - Reference conditions: ISO-Standard
- Fuel oil: LCV = 42707 kJ/kg
- * 2) - Specific Cylinder lube oil consumption

see page A2-1
for other data see page C4--1 to C4-5
see page C3-1

Ship Vibration Design Guide

Free Couples of Mass Forces

Engine Type	Number of Cylinders	R1/R2		R3/R4		R1	R2	R3	R4											
		1st Order		2nd Order						1st Order		2nd Order								
		M _{1x} kNm	M _{1y} kNm	M _{2x} kNm	M _{2y} kNm					M _{1x} kNm	M _{1y} kNm	M _{2x} kNm	M _{2y} kNm							
RTA 84 M	4	1619	1619	0	3238	*4)	3818	1416	56	834	834	0	1669	*4)	1063	730	3008	1626	3176	2424
	5	514	514	0	0	0	4754	1000	56	265	265	0	0	0	2450	979	2537	1580	2541	2013
	6	0	0	0	0	0	3307	4	56	0	0	0	0	0	1795	2	1752	1134	1755	1414
	7	266	345	0	0	0	960	0	56	137	178	130	130	0	0	0	1132	648	1135	872
	8	252	252	0	0	0	1623	0	56	290	290	290	290	0	837	0	936	800	935	960
	9	563	563	0	0	0	1142	0	56	135	135	135	135	0	589	0	479	483	477	542
	10	262	262	0	0	0	0	0	56	0	0	0	0	0	0	0	350	415	349	444
	12	0	0	0	0	0	0	0	56	0	0	0	0	0	0	0	226	312	224	328
RTA 72	4	91	846	848	0	1696	2183	330	56	446	446	0	892	118	1148	174	1903	1023	2005	1518
	5	269	269	0	0	0	2717	524	56	142	142	0	0	0	1429	276	1613	1004	1610	1269
	6	0	0	0	0	0	1890	0	56	0	0	0	0	0	994	0	1114	720	1112	892
	7	160	160	0	0	0	549	0	56	84	84	84	84	0	289	0	721	412	719	549
	8	538	538	0	0	0	0	0	56	283	283	283	283	0	0	0	591	508	592	607
RTA 62	4	106	512	561	40	1112	1385	130	76	263	268	21	572	*3)	712	57	1208	642	1275	967
	5	163	178	0	0	0	1724	240	76	84	92	0	0	0	886	123	1025	634	1024	907
	6	0	0	0	0	0	1199	48	76	0	0	0	0	0	616	24	706	455	707	567
	7	97	106	0	0	0	348	0	76	50	54	54	54	0	179	0	458	259	457	348
	8	324	356	0	0	0	0	0	76	167	183	183	183	0	0	0	378	321	379	387
RTA 52	4	126	313	313	0	625	*3)	805	91	163	163	0	326	*3)	420	16	712	381	752	558
	5	99	99	0	0	0	1003	87	91	52	52	0	0	0	523	45	604	374	633	474
	6	0	0	0	0	0	698	0	91	0	0	0	0	0	364	0	417	269	417	333
	7	59	59	0	0	0	223	0	91	31	31	31	31	0	106	0	270	153	299	205
	8	199	198	0	0	0	0	0	91	103	103	103	103	0	0	0	223	189	223	227

Remarks:

*1) M_{2x} is equal to M_{2y} with 2nd order balancer

*2) Instead of engine driven balancers, installation of electrically driven balancers may be considered. In certain installations only one engine driven balancer may be necessary.

*3) Combined 1st/2nd order balancer is not available.

*4) Not available at the moment.

Remarks:

- All free couples of 1st and 2nd order are totally balanced.
- M_{1x} = External couple 1st order vertical
- M_{1y} = External couple 1st order horizontal
- M_{2x} = External couple 2nd order vertical
- M_{2y} = External couple 2nd order horizontal

Values for other engine ratings than those given in this table can be calculated as follows:

$$M_{2x} = M_{2y} = \left(\frac{n}{n_{ref}} \right)^2$$

n: Engine speed in (rpm)

Free couple:

$$\Delta M_{2x} = \Delta M_{2y} = \Delta M_{2x} (m_{2x}) = 9.127 \cdot \Delta M_{2x}$$

7.42

Inboard:

$$m_{2x} = \frac{P_{2x}}{n_{2x} \cdot P_{2x}}$$

Mean effective pressure:

P: Engine power in (kW)

- RTA 84 M = 16.57 bar
- RTA 72 = 16.57 bar
- RTA 62 = 16.57 bar
- RTA 52 = 16.57 bar

Example:

- 6 RTA 52
- Power = 8750 kW
- Order = 92 RPM = 87.5 RPM
- R_{2x}
- Mean effective pressure:
- m_{2x} = 106.2918 = 16.57 bar
- m_{2y} = 97.5 = 14.00 bar
- Torque variation:
- ΔM_{2x} = 707 = 455 (15.67 - 9.12) + 455 = 877 kNm
- Free couples, as an example, My without 2nd order balancer:
- M_{2y} = 1199 (97.5) = 1014 kNm

MEASUREMENT AND ANALYSIS OF SHIPBOARD VIBRATION

Shipboard hull and main machinery vibration, as discussed in previous chapters, are associated with shaft, engine and propeller frequencies and their harmonics. During the design phase, these frequencies and the effect of these frequencies on the structural and mechanical response of the hull and main machinery are considered and an attempt is made to predict their response for evaluation against the established criteria or specifications. When doing so, an assumed sinusoidal driving function to the mass-elastic system involved produces an assumed sinusoidal response. Unfortunately, the actual response will generally indicate a strong modulation, with its severity significantly increased by adverse sea conditions, depth of water and ship maneuvers. Thus, a real-time record, further complicated by the presence of propeller and machinery harmonics, hull pressure forces and dynamic magnifications in the vicinity of resonances, will produce a complex and variable record. It should be apparent then, that the measurement and analysis of shipboard vibration, associated with its prediction and evaluation, can be quite involved. In this chapter, the problems associated with the subject are discussed in a manner that should provide the user with an understanding of the background and development of the current state-of-the-art of measurement and analysis of shipboard vibration. It will also emphasize the importance of standardizing the procedures for conducting ship trials and vibration measurement and analysis methods.

6.1 Background

Prior to and during World War II, the measurement of shipboard vibration was generally carried out by means of a "Geiger," a mechanical seismic instrument developed to measure torsional vibration and adaptable to measure hull vibration. The movement of the instrument, relative to a seismic mass, or the variation in angular motion, relative to the constant rotational speed of a built-in flywheel, produced a graphic trace on a spring-driven chart strip. The trace obtained was a real-time record. Frequency was determined by correlation with a marker actuated by time interval or an RPM contact. Analysis of the record was performed manually. The instrument was calibrated by the use of a fixed displacement vibration table, or, in the case of the torsional calibration, driven by a fixed displacement torsional calibrator. The instrument could only provide a single record, at one location, for a given run. The vibration recorded represented the displacement amplitude. The quantity measured was the peak value, also referred to as the maximum repetitive amplitude (MRA).

6.1.1 SNAME Vibration Program

Shortly after World War II, a research program sponsored by the Society of Naval Architects and Marine Engineers (SNAME) and the Maritime Administration (MARAD) led to the first "Code for Shipboard Hull Vibration Measurements" in 1964, [6-1], and to the original shipboard vibration instrumentation package developed for MARAD in 1965. The instrumentation package included a series of velocity transducers, signal conditioning power supplies and amplifiers, and a multi-channel oscillograph. The Code designated the locations for the transducers and the trial conditions under which the tests were to be conducted. The velocity signals were usually integrated and up to eighteen channels recorded, side-by-side, on the oscillograph for each run. The displacement amplitudes could be readily compared, for each location, as shown on the strip chart. The analysis was performed manually, as was done on the Geiger. The MRA was readily observed.

The MARAD equipment reduced the testing time and provided more useful information, but was bulky, heavy and contained many vacuum tubes, thus requiring considerable maintenance and frequent calibration. An updated version of this system was later developed with transistorized signal conditioning power supplies and amplifiers, which greatly reduced the size and weight of the system and increased its reliability. Simultaneously, the revised "Code for Shipboard Vibration Measurements," Code C-1 [6-2], was published in 1975. Data was still taken on a multi-channel, direct-recording oscillograph and/or on magnetic tape for later laboratory analysis. In all cases, the reported data represented the MRA, which was considered the appropriate quantity for the evaluation of dynamic stress against fatigue limits, or human tolerance to vibratory motion. Most of the data on which the present criteria has been established was obtained on this type of equipment.

SNAME Code C-4, "Shipboard Local Structures and Machinery Vibration Measurements," [6-3], was published in 1976 and the SNAME "Shipboard Vibration and Noise Guidelines," [6-4], was published in 1980. During this same period, very fast electronic analyzers also became available at a reasonable cost. Known as Fast Fourier Transform (FFT), these analyzers conveniently reduced the manual labor involved in data analysis but did not read the data in the same manner. This frequently led to significant differences in reported data. Resolution of this problem is still under study.

6.1.2 ISO Standards

Because of the importance of developing standardized methods of conducting shipboard vibration studies and the necessity of establishing uniformly acceptable vibration criteria for the design and acceptance of ship and machinery vibration, a working group, "Ship Vibrations," was established in 1970, under Technical Committee 108, "Shock and Vibration" and Subcommittee 2, "Machines, Vehicles and Structures," of the International Standards Organization, (ISO/TC 108/SC 2/WG 2).

To date, three ISO Standards have been published:

ISO 4867, "Code for the Measurement and Reporting of Shipboard Vibration Data," published December 1, 1984, [6-5].

ISO 4868, "Code for the Measurement and Reporting of Local Vibration Data of Ship Structures and Equipment," published November 15, 1984, [6-6].

ISO 6954, "Mechanical Vibration and Shock Guidelines for the Overall Evaluation of Vibration in Merchant Ships," published December 15, 1984, [6-7].

These standards have been based, in part, on the corresponding SNAME documents, [6-2], [6-3], and [6-4]. The most significant modifications relate to the SNAME Code, C-1, [6-2], in which measurement locations on large, direct drive diesels have been added. The vibration criteria of ISO 6954 and SNAME T & R Bulletin 2-25, [6-4], published in January, 1980, are identical. At this time we may also note that these ISO Standards are frequently used for specification and test purposes.

6.1.2.1 The Use of Shipboard Vibration Standards

When considering the measurement and analysis of shipboard vibration, it is particularly important to question the reliability of newly introduced instrumentation in providing satisfactory data that can be effectively used in complying with the ISO Standards. The following, taken from [6-8], is considered useful in understanding when and how the standards are used and the proper usage of alternate instrumentation:

ISO 4867, "Code for the Measurement and Reporting of Shipboard Vibration Data" has been developed to provide the basis for obtaining comparative data on ship vibration under uniform test conditions. As stated, "Such data are necessary to establish uniformly the vibration characteristics of hull and propulsion shaft systems and to provide a basis for design predictions, improvements and comparison against vibration reference levels." Thus, for purposes of reporting test data, specific frequencies and amplitudes related to hull and main machinery response characteristics are identified. This procedure also permits the identification of sources of potential problems, should the need arise during ship trials.

ISO 4868, "Code for the Measurement and Reporting of Local Vibration Data of Ship Structures and Equipment." As stated, "the term 'local vibration,' as used in the shipbuilding industry, applies to the dynamic response of a structural element, an assembly of structural elements, machinery or equipment, which vibrates at an amplitude significantly greater than that of the basic hull girder at the location." Also, as stated, "Such data are necessary to establish uniformly the vibration characteristics present in various compartments on board ship and to provide a basis for design predictions, improvements and comparison against environmental vibration reference levels or criteria relative to reliability (of machines), safety (of structures) and habitability." This International Standard "is concerned with local vibration measured on structural elements, superstructure, decks, bulkheads, masts, machines, foundations, equipment, etc., and only relates to the measurement and reporting of the local vibration of the

Ship Vibration Design Guide

structure or equipment mounted thereon. Concern over local vibration may be caused by:

- a. Stresses due to the vibration, for example, in the structure, in the equipment or attachments;
- b. The necessity of maintaining trouble-free operation of a machine or other equipment that might be jeopardized by the malfunction or degradation of components;
- c. Physical strain on man (habitability and performance);
- d. Effects of the vibration on its environment, such as adjacent instruments, machines, equipment, etc."

ISO 6954, "Guidelines for the Overall Evaluation of Vibration in Merchant Ships," applies to the overall evaluation of the vibration of ship structures. Evaluation of vibration exposure specifically with respect to human safety, performance capability and comfort experienced by crew members should be based on vibration measurements specified in ISO 2631/1, "Guide for the Evaluation of Human Exposure to Whole-body Vibration - Part 1: General requirements."

For convenience, the Annex of ISO 6954 deals with the compatibility with ISO 2631/1 and states:

"Shipboard vibration generally approximates to narrow-band vibration and a crest factor of 2.5 is commonly encountered. In these circumstances, the maximum repetitive vibration is more appropriate than the Root Mean Square (rms) value with regard to evaluation of overall ship vibration. This International Standard evaluates overall shipboard vibration in terms of maximum repetitive values and, for comparison with rms values, the crest factor shall be taken into account.

"In ISO 2631/1, the effect of vibration on human beings is evaluated by reference to curves of rms acceleration, taking the evaluation to apply over a wide range of crest factors.

"If the vibration value is below the guidelines specified in this International Standard, it will also satisfy the guidelines in ISO 2631/1 with respect to crew exposure to whole body vibration."

The above referenced Codes (ISO 4867 & 4868) and Guidelines (ISO 6954) may be used in specifying and/or evaluating shipboard vibration against selected vibration reference levels. These codes and guidelines are applicable to ship hulls, main propulsion machinery systems, local structures, machines and equipment. As noted in the guidelines, "evaluation of vibration exposure, specifically with respect to human safety, performance capability and comfort

Measurement and Analysis of Shipboard Vibration

experienced by crew members should be based on vibration measurements specified in ISO 2631/1." However, it is also noted, that if the vibration level is below the guidelines specified in ISO 6954, it will also satisfy the guidelines in ISO 2631/1.

The guidelines given in ISO 6954 reflect the experience of the international shipbuilding community prior to the establishment of ISO/TC108/SC2/WG2 in 1970 and is based on oscillographic data, represented by the maximum repetitive amplitude (MRA). A typical vibration recording of blade-frequency hull vibration obtained under the specified trial conditions is shown on Figure 6-3. The original more complex recording has been filtered to isolate the blade-frequency response. The envelope shown on the record represents the MRA for that frequency, which should be used for evaluation purposes against the guidelines shown in ISO 6954. Due to the heavy modulation of the signal, the average rms crest factor was determined to be 2.5, ($C_f \sqrt{2}$), for the hull girder vibration and the longitudinal vibration of the bull gear, and agrees with the value given in the note under paragraph 3 of ISO 6954.

Although it is not appropriate to specify any particular instrumentation to be used for test purposes, it is necessary that whatever equipment is used should give the same result. Thus, if a spectral analysis is preferred, the average rms value at any particular run should be multiplied by the 2.5 crest factor for comparison with a typical oscillographic recording and with the guidelines. As an alternative, a second set of guidelines adjusted downward by the same 2.5 crest factor could be used for direct comparison with the average rms spectra. The peak rms spectrum should not be used since it does not represent the MRA and was found to differ significantly on different instruments as frequency and speed varied.

Significant variations in crest factor values can be expected in the presence of harmonics of blade-frequency and in adverse sea conditions. However, minor variations can be expected in crest factor values at some alternate measurement locations and on smaller ships, which would produce greater signal modulation in the same seaway. If the vibration observed is found to be questionable with regard to contractual requirements, filtering and/or direct recording is recommended for a more exact evaluation. To provide the capability to accomplish this after the trials, it is recommended that all test data be recorded on tape.

Finally, it is submitted, that although the criteria provided in the guidelines (ISO 6954) is based on the subjective evaluation of seafaring personnel, it does reflect the state-of-the-art of vibration evaluation of ship hulls and main propulsion machinery systems and would meet the criteria of ISO 2631/1. However, in their usage, as in all similar cases, standards are treated as absolutes, with a "go/no go" philosophy. Thus, if we all used oscillographic data, as was necessarily done in the past, and on which the criteria were established, there would be good agreement on test results, just as we had good agreement in average rms spectra, as noted in Genoa, in 1986 when comparative analyses of a given tape were made by members of the ISO Working Group. Our remaining problem is to keep in mind that which our criteria represent (MRA) and when we employ, or propose to employ, other instrumentation or techniques, that we do so with our eye on the standard as it exists. It can be modified and updated in future issues, but this should not be controlled by the requirement for the use of particular instrumentation without adequate justification.

6.2 Instrumentation

This section will provide the information on mechanical instruments, vibration transducers, signal conditioning and recording equipment that would have to be considered in planning shipboard vibration measurements. It treats the various types of equipment in general terms. When specific equipment is selected, reference will have to be made to the manufacturer's instructions for the actual operation of the equipment.

6.2.1 Mechanical Instruments

There have been many mechanical and optical instruments developed for measuring vibration, most of them before electronic means were highly developed. Two of the most common are still used and are briefly described.

6.2.1.1 Reeds

These instruments consist of metal reeds attached to a case that is held hard against a vibrating object. If the natural frequency of the reed coincides with the frequency of vibration, the reed's amplitude will be magnified to the point where it can be seen. One type of reed instrument (Frahm reeds) has a number of reeds of different lengths (and frequencies) attached to the same case, and the reed with the highest amplitude is closest to the frequency of vibration. Other instruments use a tunable reed where the length can be adjusted. The amplitude of the reed can be calibrated to give the amplitude of vibration (Westinghouse Reed Vibrometer).

6.2.1.2 Askania

This is a hand-held instrument with a probe that is pressed against a vibrating object. The relative displacement between the probe and the casing is mechanically amplified and displayed on a 1-inch wide strip of paper as a time history, from which the amplitudes and frequencies of vibration can be determined. Low frequency signals are often unreliable due to the difficulty in holding the instrument still.

6.2.2 Transducers

Several of the basic types of transducers used for vibration measurements are discussed. The theory of operation is intentionally very brief, but the features that must be considered in their application are covered in more detail. The type of transducers chosen will depend on what type of information is required.

6.2.2.1 Accelerometers

The most common type of accelerometer is the piezoelectric type. This consists of a mass mounted on a crystal, which generates an electrical charge proportional to the acceleration of the mass. It is generally small in size and models can be found that can measure from 1 Hz to 10 kHz. They require a charge amplifier and the cables from the transducers to the amplifiers must be coaxial. If the cables between the transducers and amplifiers are long and/or are subject to vibration, a charge converter should be inserted in the cable a few feet from the transducer. A two-conductor shielded cable can be used between the charge converter and the amplifier.

Measurement and Analysis of Shipboard Vibration

If frequencies down to D.C. must be measured, a strain gage or piezoresistive accelerometer can be used. The strain gage type has the mass mounted to a flexural or other support that bends or deflects when the accelerometer vibrates. Strain gages are used on the support to measure deflections. The piezoresistive types have the mass mounted to piezoresistive elements that act much as strain gages do. These must be used in conjunction with strain gage amplifiers. Four conductor-shielded cables must be used between the gages and the amplifiers.

Another type of accelerometer is the servo accelerometer. This type contains a seismic mass with a coil of wire around it. Motion of the mass with respect to the case due to acceleration is detected and a current imposed on the coil to keep the mass moving with the case. The amount of the current is the signal output. The frequency response of one brand of this type is from D.C. to approximately 500 Hz. It has a built-in amplifier and requires a D.C. power supply.

Acceleration signals are suitable for analyzing many types of machinery problems where high frequencies are of interest, such as bearing wear, because the high frequencies are accentuated. However, if lower frequencies are of interest, such as a once per revolution signal, that signal may be lost in a multitude of high frequency signals due to bearings, flow noise, etc. In the analysis section, some techniques will be discussed to overcome this problem.

6.2.2.2 Velocity Gages

A velocity gage is constructed with a magnetic core mounted on springs, that oscillates within a coil, generating a signal, which is proportional to velocity. It generally has an internal resonant frequency of 5 or 6 Hz, is highly damped to eliminate a high output at the resonance and has a useful frequency range of about 4 to 600 Hz. The lower frequencies require a correction but above approximately 10 Hz, the output is essentially linear. Two conductor shielded cables are sufficient for velocity gages. The velocity signal, and alternatively the displacement signal if it is integrated, is usually the most appropriate quantity to measure for ship vibration problems if high and very low frequencies are not of interest.

6.2.2.3 Displacement Gages

The most common type of gage measuring displacement directly is the non-contact proximity probe. It generally consists of a proximator and a probe. The proximator generates a high frequency signal, which produces a magnetic field around the probe. The closeness of a metal "target" alters the eddy currents, thus modulating the high frequency signal, which is demodulated by the proximator producing a signal that is proportional to the distance between the probe and the target. The frequency response is from D.C. to several kHz depending on the frequency of the carrier. The proximator requires a D.C. power supply. Cable between the proximator and the recorder or signal conditioner can be two conductor shielded.

The proximity probe is used extensively in rotating machinery studies to measure the relative displacement between stationary and rotating parts. If the actual displacement of a rotating body is required, the displacement of the casing, or whatever the probe is mounted to, must be measured by some other means. The most severe limitation of these is that they measure only a range of a few to 50 or 100 mils displacement, unless the probe is quite large.

There are other displacement measuring transducers that have each end mounted to objects to measure the relative distance between them. Two such devices are the Linear Variable Displacement Transducer (LVDT) and the Linear Motion Transducer (LMT).

6.2.2.4 Strain Gages

Strain gages are resistive elements that change their resistance when they are stretched or compressed. They are mounted with an adhesive to the object and in the direction in which strain is to be measured. The change in resistance is small so the measurement is usually made with the gage electrically connected in a Wheatstone bridge. A D.C. power supply of 5 to 10 volts is required. Often this is built into strain gage amplifiers.

If the strain in a shaft is being measured, telemetry equipment or slip rings must be used. The arrangements of the gages for measuring axial, torsional and bending strains in the shaft are all different, and must be precisely positioned. The techniques for installation, calibration and measurement are quite involved and require experienced personnel.

6.2.3 Signal Conditioners

Signal conditioning equipment is used to amplify signals to a level where they can be conveniently recorded or displayed. Depending on the application, they may also include power supplies for the transducers, filters, calibration features, integrators and parts of Wheatstone bridge circuits.

6.2.3.1 Differential Amplifiers

Differential amplifiers in their simplest form use voltage inputs and merely amplify them to a level suitable for recording. The most common additional feature found on these is an internal calibration signal, which is fed into the amplifier. This could be a sinusoidal signal or a D.C. step of known value. This is convenient for calibration of the amplifier and recording equipment, but does not calibrate the sensitivity of the transducer. That would have to be done by other means or provided by the transducer manufacturer.

The output of this or any type of amplifier is usually a voltage that can be used as input to high impedance devices only. This would include tape recorders, many strip chart recorders, spectral analyzers, oscilloscopes, etc. The most common low impedance device used is an oscillograph that uses galvanometers. These are designed such that the display is proportional to the input current rather than voltage. Special "galvo outputs" are required on the amplifiers to drive these devices.

6.2.3.2 Charge Amplifiers

Charge amplifiers are used with piezoelectric accelerometers to convert the charge generated by the accelerometer to a voltage proportional to acceleration. Some of these have a feature that allows the use of remote charge converters, in which case the amplifiers become basically differential amplifiers. In addition, they provide a D.C. power supply superimposed on the signal cables to power the remote charge converters. If remote charge converters are used, it is possible to use a separate power supply and differential amplifiers, provided the charge converters have the appropriate connectors.

Since acceleration signals often have large amplitude high frequency signals, which are not of interest, charge amplifiers often have built-in filters to limit the amplifier output to 50, 100, 500 Hz, etc. If velocity or displacement is desired, some amplifiers can integrate the signal once to get velocity, or twice to get displacement. If this feature is used, the characteristics of the integrators at low frequencies should be checked. Often the transducer can be used at lower frequencies than the integrators.

Charge amplifiers, like differential amplifiers, may have internal calibration signals and/or galvanometer outputs as well as voltage outputs.

6.2.3.3 Strain Gage Amplifiers

A strain gage amplifier is basically a differential amplifier, but usually includes most of the following features. It should have a D.C. power supply rated at up to 10 volts. It usually has a shunt calibration switch that places a calibration resistor across one arm of the bridge. This changes the resistance of that arm to correspond to a known strain.

The strain gage amplifier also has a bridge balance network that adjusts the voltage across adjacent arms to zero the output when the structure being measured is not under load. Again it is recommended that only experienced personnel be used for strain measurements.

6.2.3.4 Filters

The most common type of filter used in ship vibration measurements is a low pass filter, which passes all frequencies below a set frequency and blocks all those above it. As mentioned before, this can be used to eliminate high frequencies such as *from bearings, flow, etc.* The "cut-off" is not sharp, however, and the filter characteristics should be considered when using them. A high pass filter can be used to eliminate unwanted low frequencies, such as ship motion or low frequency hull vibration. Again, the cutoff is not sharp.

Both high pass and low pass filters can be used on the same signals, either as a "band-pass" filter or as a "band-reject" filter. The band-pass filter would be used if there are both low frequency and high frequency signals that are unwanted. Also, it might be used to isolate a certain component, such as blade frequency, in which case a narrow band would be used. More will be said about filters in the analysis section.

6.2.4 Recorders

This section discusses four means of recording or observing vibration data: meters, oscilloscopes, oscillographs and tape recorders. *Often data is fed directly into a frequency analyzer and the peaks recorded by hand or the entire plot put on hard copy.* Although this can be considered a type of recording, frequency analyzers are discussed under Section 6.4, Analysis and Reporting of Data.

6.2.4.1 Meters

In the simplest type of display used for vibration data, the amplitude of the A.C. component of a signal is displayed on a meter. If there are no filters in the signal conditioning system, the meter displays an "over-all" level of vibration and no indication of the frequencies involved.

Ship Vibration Design Guide

This is useful for many machinery monitoring applications where a change in overall vibration level is usually indicative of a problem. Sometimes enough is known about the machine that the frequency can be assumed. More often, some type of frequency detection is used for diagnostic purposes after a problem has been detected.

A filter can be used in conjunction with a meter to obtain the frequencies and amplitudes of many of the components in the signal. Normally, a narrow band filter is used in this manner and is tuned manually. This procedure is severely limited by the gradual cut-off of most analog filters and results in lower level components being masked by the higher level signals if they are close in frequency. "Close in frequency" will be defined differently for different filters, but could be a factor of two or three. Also, two components that are very close are difficult to distinguish. Nevertheless, this procedure is very useful for many applications that have a limited number of frequency components.

A meter, be it with or without a filter, is used mostly with machinery where the amplitudes do not modulate significantly. Most hull, superstructure and main shaft vibration measurements exhibit a modulation such that the maximum amplitudes are two to five times the average. This modulation varies with the quantity being measured, sea state and other factors. At any rate, it is difficult to deal with using a meter because the needle fluctuates too much to get a good reading. Also, the modulating signal is a statistical quantity and a sufficient number of cycles must be observed. This is impossible with a meter. Many packages are available from manufacturers, such as IRD, that include a transducer, tunable filter and calibrated meter.

6.2.4.2 Oscilloscopes

Oscilloscopes can display a time history of the vibration signal on a screen as it occurs. In many scopes a segment of the signal can be "captured" and retained for examination. The amplitude of the signal can be read from the screen if it is not modulating too much. If there is a dominant frequency component, the frequency can be obtained from the screen as well, by observing the period on the x-axis. If there is more than one frequency component, getting frequency information from a scope is difficult.

Oscilloscopes are more useful as monitoring devices to see if a reasonable looking signal is being recorded and to observe the general characteristics of the signals. For multiple channels it should be used with a switchbox so all channels can be checked. Precise measurements of the amplitudes and frequencies should be done by other means. See Section 6.3.

6.2.4.3 Oscillographs

Oscillographs produce a hard copy of the time history of a number of vibration signals simultaneously, allowing these permanent records to be analyzed any time after the data is taken. The procedures for obtaining the amplitudes and frequencies from these records are given in Manley [4-1], and briefly discussed in Section 6.4.1.

Where there are several modulating frequency components in a single signal, it becomes difficult and time consuming to analyze. Oscillographs are often used in preliminary analyses and to get a feel for what is happening during the trial. It can also serve as a backup in case something should happen to a tape recorder used in parallel.

The distinction between "oscillographs" and "strip chart recorders" is somewhat vague. In general, a strip chart recorder has a pen, perhaps thermal or ink and is limited to a frequency response of 100 Hz or less. An oscillograph usually refers to a recorder that uses light beams directed towards a roll of light sensitive paper. Its frequency response could be as high as 5 kHz. The light beams might be controlled by galvanometers, in which case a small mirror reflects a light source in response to the incoming signal. A later innovation uses fiber optics to direct the light.

Galvanometers have low input impedance and are current controlled devices. Signal conditioning equipment used with galvanometers must have an output terminal designed specifically for them. The fiber optic equipment and strip chart recorders normally have differential amplifiers built in with gain controls, so that the same signal can be used for the oscillograph or strip chart recorder as is used for the tape recorder.

6.2.4.4 Tape Recorders

The use of a tape recorder provides a versatility that cannot be obtained by the other methods discussed. It reproduces the electrical signal, which can then be analyzed by any method desired. This flexibility is desirable because the requirements for analysis cannot always be totally predicted before the trial. The procedures involved are fairly simple, but must be rigorously observed.

The level of the input signals must be constantly observed and controlled by the signal conditioning equipment so that the signal is as large as possible to reduce the signal/noise ratio, but not too large for the tape recorder, so the signal is not clipped. The level can often be monitored with a meter built into the tape recorder. An alternative method is to monitor the level on an oscilloscope.

An oscilloscope is desirable anyway to judge whether the signals look reasonable or not. Usually intermittent connections, 60 Hz noise, or other problems can be instantly detected. The scope should be used also to monitor the tape's reproduced signals **AS THEY ARE BEING RECORDED**. This will require extra wiring and switching arrangements, but it is imperative that the trial engineer be able to routinely check if all signals are the same when they are reproduced as they were when recorded.

The tape speed selected will depend on the frequency response of the signals to be recorded and whether the tape recorder uses "wide band" or "standard band." Check the instructions for the recorder to select tape speed.

6.3 Quantities To Be Measured

The first choice to be made regarding the type of data to be recorded is between displacement, velocity and acceleration. In addition, the appropriate frequency range should be known in advance. Although most ship vibration data will be recorded in the form of a time history, sometimes the data will be fed directly to a frequency analyzer or other analysis equipment and a hard copy of the frequency spectra or some other type of plot will be obtained. In some very simple applications, data may be read from the equipment and recorded manually as the trial is conducted. This section discusses the measured quantities in general. Section 6.5 (Transducer Locations) makes specific recommendations for different situations.

6.3.1 Displacement, Velocity, or Acceleration

In most cases ship vibration data will be analyzed in terms of its frequency components, so the characteristics of sinusoidal motion should be considered. The displacement, velocity and acceleration amplitudes of sinusoids differ only by factors of the frequency, with the higher frequencies being accentuated by acceleration and the lower by displacement. Vibration engineers often consider displacement the appropriate quantity to observe for machines that operate below 1000 RPM, velocity for 1000 to 10,000 RPM, and acceleration for those above 10,000 RPM. This is assuming they are interested in things such as unbalance, misalignment, etc. If a high frequency, such as a bearing frequency, is of interest even on a low speed machine, acceleration may be the best quantity to observe.

Another factor to consider in choosing displacement, velocity or acceleration is what is critical in determining damage to the machine or structure. Displacements will normally be proportional to stresses in a structure and can be compared to known clearances, etc. Velocity gives an indication of the energy dissipated through vibration, which is often a good indicator of damage to a machine. Human comfort level is more closely related to velocity than displacement or acceleration. Acceleration is normally proportional to the forces applied to the vibrating object. The final choice is often determined by the characteristics of the transducers available, particularly the frequency range of the transducer. See the section on transducers for details.

6.3.2 Frequency Range

The frequency ranges of transducers, signal conditioners and recording equipment must be chosen to match the frequency components of interest in the data being recorded. Also, frequencies known to be present but not of interest are often excluded. Ship motion (roll, pitch, etc.) usually falls below 1 Hz. Hull girder modes and those of major structures, such as deckhouses, masts, etc. may be from 1 to 10 Hz for the lower modes. Propeller shaft rotation, main engine rotation, gear frequencies and blade rate can all be determined from the machinery characteristics.

Even though unwanted frequencies can be filtered out in the analysis of the data, it may be a good idea not to record them in the first place because the level of the frequency components of interest will be harder to separate from the "noise" later. Also, in the case of frequency analyzers, choosing a broader frequency range than necessary will decrease the resolution and accuracy of the results.

6.3.3 Time History or Frequency Spectra

Often it is tempting to obtain frequency spectra directly rather than go through the step of recording on tape and then later obtaining the spectra. This is appropriate for rotating machinery where the vibration is self-excited. In this case, the amplitudes are usually fairly constant and a large sample is not required. Most vibration data routinely gathered from ships, however, are excited by the sea, propeller or some combination, such as hull girder vibration. For this type of data, the amplitudes are modulated and have a randomness associated with them and require a sample long enough to account for the randomness, which for blade frequencies and its harmonics should be two or three minutes. If multiple channels are being recorded, as is usually the case, this will not permit "on-line" analysis during the trials.

6.4 Analysis and Reporting Of Data

Traditionally, analysis of shipboard vibration records has been performed using the methods described in "Waveform Analysis" by R.G. Manley [4-1]. The various schemes proposed in that work allow one to extract maximum values and frequencies of the components of a complex waveform. If there are several components present, "manual" analysis is time consuming and requires good judgment (i.e., experience). Common practice has been to analyze a record of one to several minutes duration and report the "maximum repetitive" amplitudes of the predominant components. This practice was established because the maximum values are those responsible for discomfort and structural damage.

Recently, very fast digital electronic analyzers have become available at a reasonable cost. These analyzers offer several advantages over manual analysis, primarily speed and repeatability. No judgment is required by the machine. Unfortunately, the machines do not look at data the same way as experienced vibration engineers. Most of these machines perform a discrete Fourier transform on an electrical analog of the vibration waveform. The analysis is accomplished by an efficient algorithm known as a Fast Fourier Transform. The result of this transform is the Root Mean Square (rms) amplitude of each component within the analysis range. For a pure sinusoid, the ratio of the peak amplitude to the rms amplitude is $\sqrt{2}$. In order to obtain the maximum repetitive values, the rms values must be multiplied by "crest factors," which include both the $\sqrt{2}$ factor and an amplitude modulation factor. There are limited data on crest factors at present, but they are known to vary with sea state and location of measurement. Normally, they are in the range of 2 to 4, but in adverse weather, values as high as 6 to 9 have been reported. The International Standards Organization (ISO) recommends that a factor of 2.5 be used unless there is enough data available to establish a more appropriate factor.

Six methods of analysis are discussed below. Not enough research has been done to evaluate these methods in relation to each other, but each has its own advantages and can be used to compare quantities analyzed by similar methods.

6.4.1 Manual Method

The "manual" method of analysis involves measuring frequencies and amplitudes of vibration components on an oscillograph record. The subject is covered in great detail in Manley [6-9], and only a few basics are covered here.

The analysis of waveforms is based on the principle that any periodic record is a superposition of sinusoids having frequencies that are integral multiples of the lowest frequency present. The lowest frequency is determined by the smallest portion of the record that repeats itself, or one cycle. Figure 6-1 shows several waveforms and indicates the extent of one cycle, some of which are not obvious.

The first trace (a), is essentially a sinusoid with a constant amplitude. The double amplitude of vibration is obtained by measuring the double amplitude of the trace as shown and multiplying by the sensitivity of the measuring/recording system, which is found by calibration. The frequency is found by counting the number of cycles in a known time period. The time on oscillographs is indicated by timing lines (a convenient rate for many shipboard applications is 10 lines/sec.) or simply by knowing paper speed. For trace (a), the frequency is 6 Hz. Accuracy is improved if the number of cycles in a longer section of record is used.

Ship Vibration Design Guide

Trace (b) is the superposition of two sinusoids with one cycle of the lowest frequency shown. The components can be separated by drawing sinusoidal "envelopes" (upper and lower limits) through all the peaks and troughs as shown. The amplitude and frequency of the low frequency component is that of the envelope (frequency is about 2.7 Hz). The vertical distance between envelopes indicates the amplitude of the high frequency component and the high frequency (about 8 Hz) can usually be counted. In this example, the frequencies differ by a factor of three.

Often signals look like trace (c), where the envelopes are out of phase, causing "bulges" and "waists." This signal is caused by two components that are close in frequency and is called "beating." The peaks of the two signals alternately add and subtract. Other characteristics of beating are that the lengths of the beats are about the same and the spacing between the peaks at the bulges is different from that at the waists. The amplitudes between the envelopes at the bulges and waists represent the sum and difference respectively of the components. Thus, if the components' amplitudes are x_m for the major and x_n for the minor, measurements show that:

$$x_m + x_n = .7 \text{ in}$$

$$x_m - x_n = .2 \text{ in}$$

Solving simultaneously by adding:

$$2x_m = .9 \text{ in or } x_m = .45 \text{ in and } x_n = .25 \text{ in}$$

These record amplitudes must be multiplied by the system sensitivity to get actual amplitudes. The major frequency can be found by counting the number of peaks as before. In trace (c) it is 3 Hz. This frequency is also some integral multiple of the beat frequency, in this case 6 times. The frequency of the minor component is either one more (7), or one less (5), times the beat frequency. The spacing of peaks at the waist indicates this since it reflects the major component. In trace (c) the spacing is closer so the major component has the higher frequency. If the spacing were farther apart, the major component would have the lower frequency. In this example, the beat frequency is 0.5 Hz, the minor frequency is 5 times that, or 2.5 Hz.

Trace (d) shows a characteristic of most hull and propeller excited vibration on board ships. It looks similar to beating, but is actually only one component whose amplitude is varying (modulating) in response to wave action and flow variations into the propeller. This is distinguishable from beating because the length of the bulges are not likely to be the same and the spacing of the peaks is the same at the bulges and the waists. For such records, the maximum repetitive amplitude is usually desired, which would be obtained from the highest bulges.

Unfortunately, many ship vibration records involve more than two components, will almost certainly involve modulation and may be beating as well. One technique that saves a lot of time is to find sections of the record in which one component is temporarily dominant.

Measurement and Analysis of Shipboard Vibration

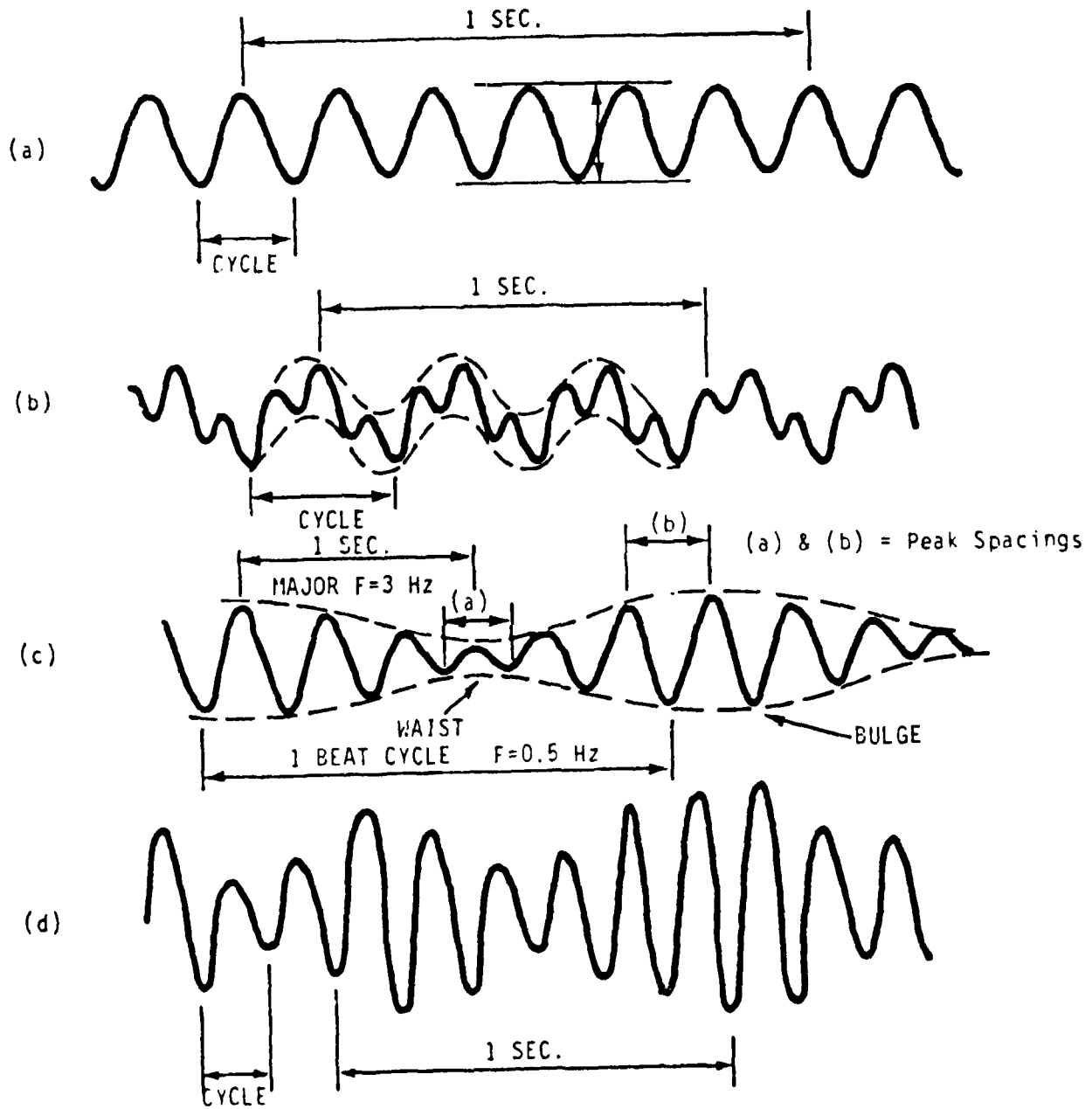

Figure 6-1
Various Types of Waveforms

6.4.2 Envelope Method

This method of analysis involves filtering the signals to get the frequency component of interest and recording the result on a chart recorder at slow speed. This condenses a several minute record into an envelope just several inches long. The maximum repetitive value (MRV) can be immediately obtained visually.

Care must be taken that the filter used does not pass a significant amount of any component other than the component of interest. As an example, using most analog filters to obtain blade frequency (frequency at which propeller blades pass a fixed point) is normally acceptable because the amplitude of the second harmonic is usually much lower than that of blade frequency. However, when analyzing the 2 x blade component, too much of the blade and the 3 x blade component would pass to obtain meaningful results.

To illustrate how these errors can be anticipated, consider a Krohn-Hite Model 3550 Variable Filter. It uses a fourth order Butterworth function. The gain is given by Figure 6-2 and the following:

$$G_L = \frac{1}{\sqrt{1 + S^8}}$$

$$G_H = \frac{S^4}{\sqrt{1 + S^8}}$$

$$S = \frac{f}{f_o}$$

where:

G_L = Gain of low pass filter

G_H = Gain of high pass filter

f = Frequency

f_o = Cut-off frequency setting

The effect that this filter will have on blade frequency and its harmonics can be illustrated by calculating the attenuations for various frequency ratios, S . The results are given in Table 6-1. It was assumed that the high pass and low pass filter settings were at 80 percent and 120 percent of the frequency being passed.

From Table 6-1, it can be seen that using the filter attenuates the wanted signal to 83.3 percent. Any results so obtained should be divided by .833 to get true amplitudes. To see how this step affects all the components, the entire table is divided by .833 to find the "normalized" attenuations.

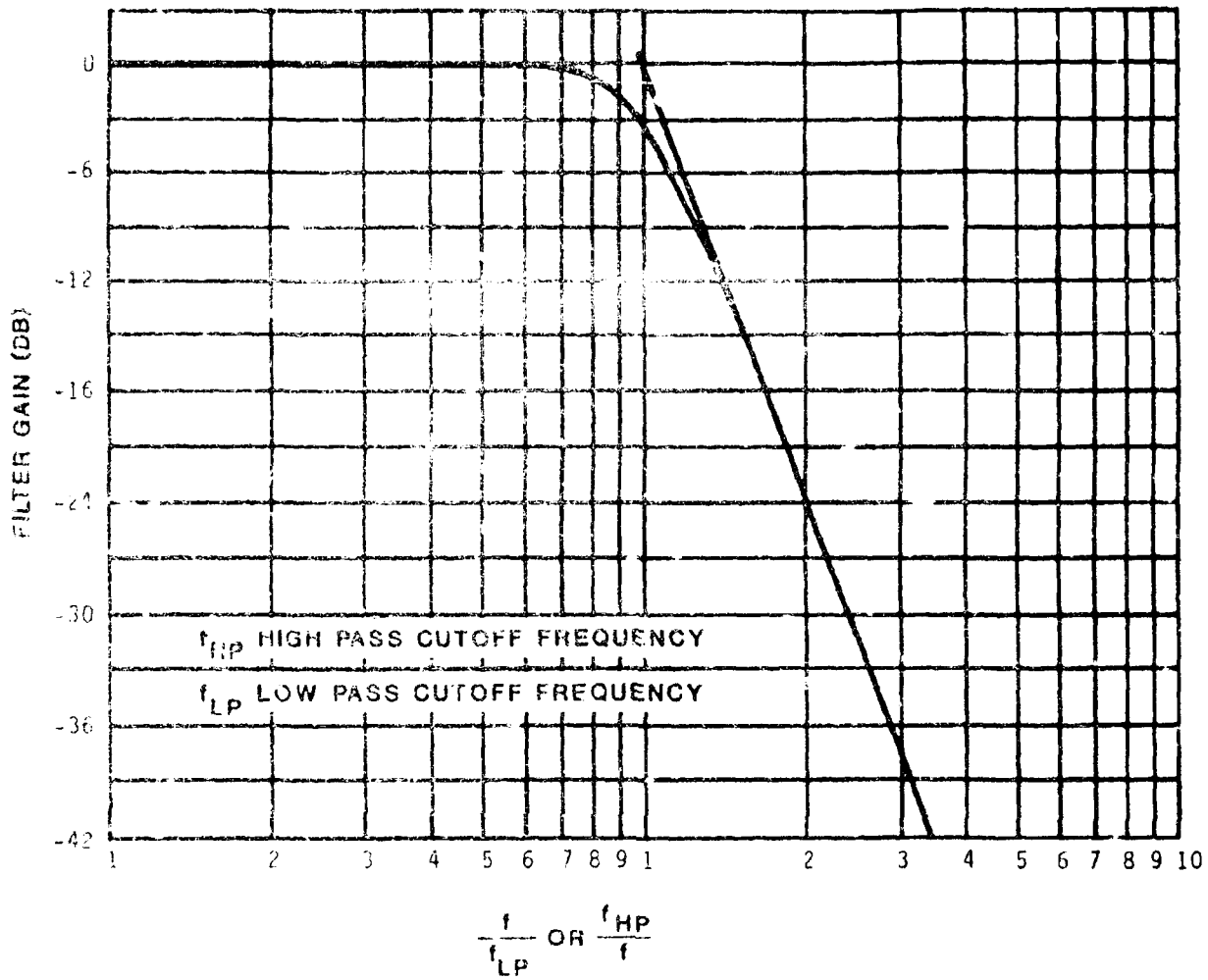

Figure 6-2

Normalized Attenuation Characteristics of Krohn-Hite 3550 Filters

Table 6-1 Calculated Attenuations Due to One Filter

Filter Setting	Actual Attenuations				Normalized Attenuations			
	Blade	2 x Blade	3 x Blade	4 x Blade	Blade	2 x Blade	3 x Blade	4 x Blade
Blade	833	128	.026	.008	1.000	.154	.031	.010
2 x Blade	.151	833	.378	.128	.181	1.000	.454	.154
3 x Blade	.030	.432	833	.544	.036	.519	1.000	.653
4 x Blade	.009	.151	.604	.833	.011	.181	.725	1.000

Ship Vibration Design Guide

The normalized attenuations show that if blade frequency is being filtered, 15.4 percent of the second harmonic also passes, an acceptable error if the second harmonic is significantly less than blade frequency, which is the usual case. When analyzing the 2 x blade component, 18.1 percent of the blade and 45.4 percent of the 3 x blade passes, an unacceptable error.

To reduce this type of error, two filters can be used in series (Table 6-2). When analyzing 2 x blade, two filters result in 69.4 percent of 2 x blade, 2.3 percent of blade and 14.3 percent of 3 x blade being passed. To normalize, divide by .694. The normalized attenuations show 3.3 percent of blade and 20.6 percent of 3 x blade is passed. This technique should be acceptable unless the 3 x blade component is unusually high in magnitude. Even two filters may not have a sharp enough cut-off to isolate the 3 x blade or higher harmonics.

Table 6-2 Calculated Attenuations Due to Two Filters

Filter Setting	Actual Attenuations				Normalized Attenuations			
	Blade	2 x Blade	3 x Blade	4 x Blade	Blade	2 x Blade	3 x Blade	4 x Blade
Blade	.694	.016	.001	.000	1.000	.024	.001	.000
2 x Blade	.023	.694	.143	.016	.033	1.000	.206	.024
3 x Blade	.001	.187	.694	.296	.001	.269	1.000	.426
4 x Blade	.000	.023	.365	.694	.000	.033	.526	1.000

For normal ship vibration signals, the following steps are recommended:

- Analyze blade frequency with one filter and normalize results.
- Analyze 2 x blade frequency with two filters and normalize results.
- Subtract 15.4 percent of the 2 x blade amplitude from the blade frequency amplitude.
- Subtract 3.3 percent of the blade frequency amplitude from the 2 x blade amplitude.

NOTE: The above percentages will vary with different filters.

In order to visualize the relationship between a normal oscillograph record of ship vibration and a condensed envelope, a sample of filtered blade frequency vibration of a ship's stern was recorded at different speeds. Figure 6-3 shows the record at 25 mm/sec. Figure 6-4 shows the same record at successively slower speeds. At 1 mm/sec the maximum repetitive value is conveniently read. It is felt that this is presently the best method to obtain the MRV for blade and 2 x blade frequency from ship vibration records.

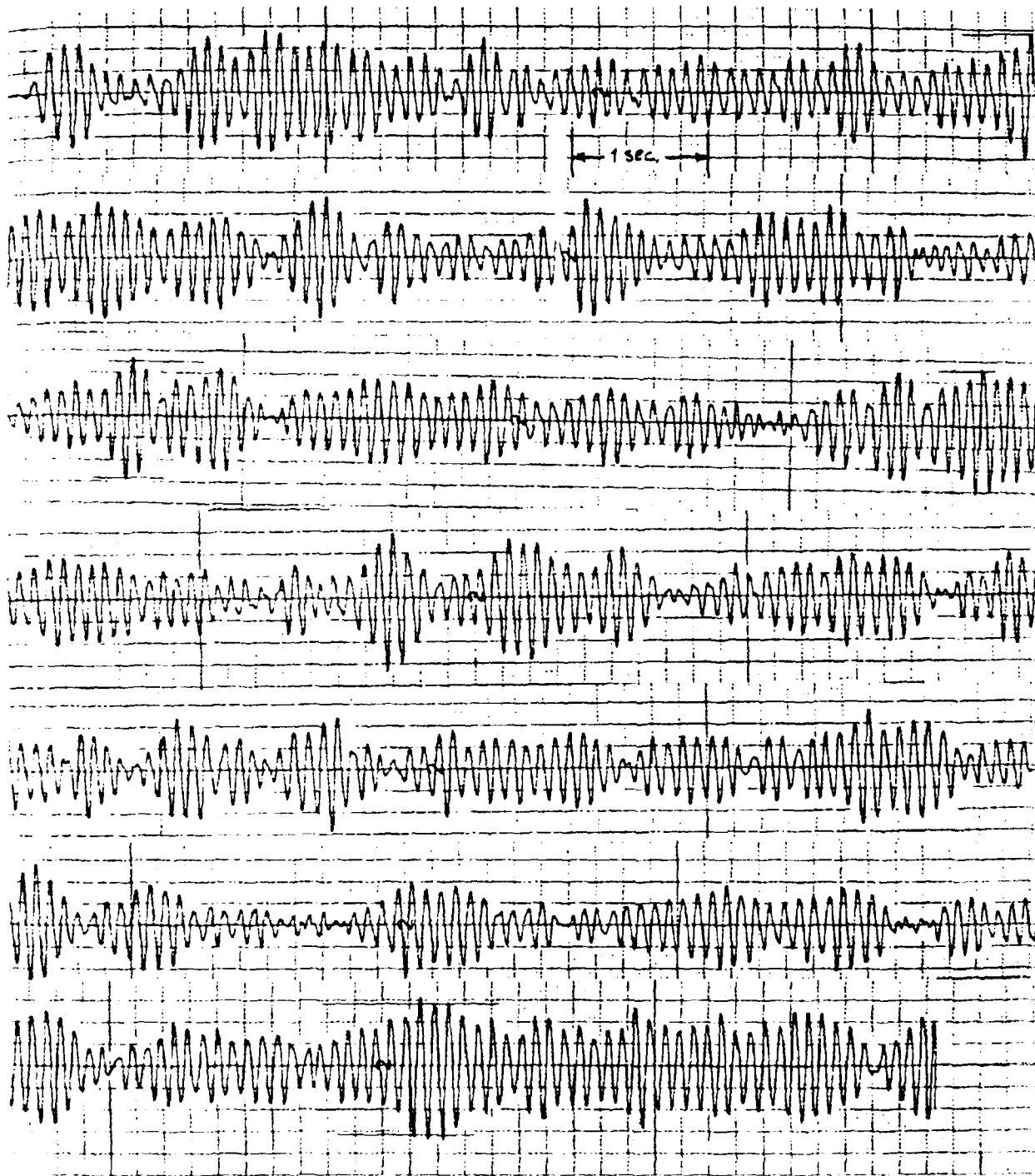
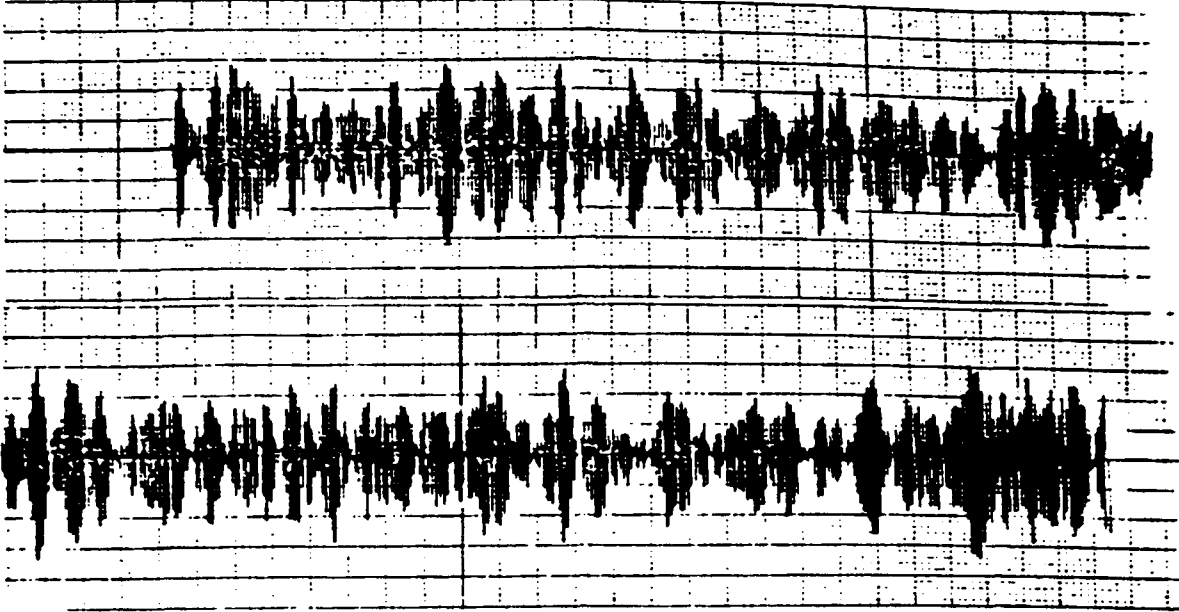
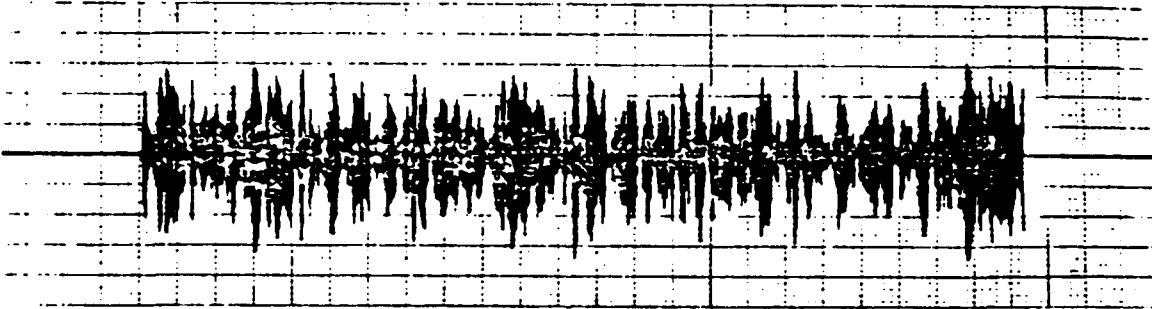

Figure 6-3

Vertical Blade Frequency Displacement of a Ship's Stern



5 mm/sec



2 1/12 mm/sec (125 mm/min.)

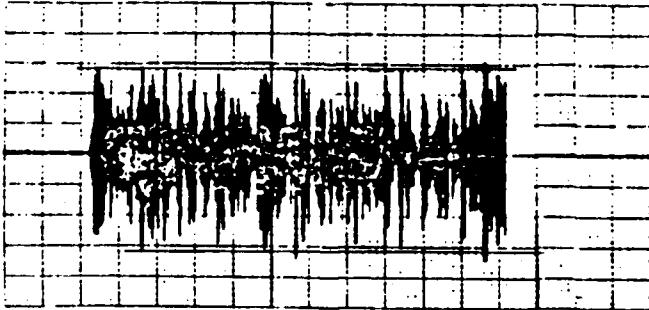

Figure 6-4
Vertical Blade Frequency Displacement of a Ship's Stern
Recorded at Various Slow Speeds

6.4.3 Spectral Method

Two types of spectra can be found with most analyzers: the common "average" and the "peak" amplitude. For both types the record is broken down into segments for frequency analysis. The segments vary in length with the frequency range of the analysis, but for ship vibration studies they would be several seconds long. For each segment, the analyzer finds the rms level of each frequency component (i.e., in each frequency interval, or for each "line"). The number of lines (resolution) varies with the analyzer, but most often falls between 100 and 1000. Ship vibration records will normally be one or several minutes long and will contain many segments. If the "average" spectrum is desired, the analyzer will average all the rms levels found in like frequency intervals. The term "number of averages" is often used referring to the number of segments in each average, although the terminology is sometimes confusing. This report will refer to the values obtained with "average" spectra as "average rms" values.

Before proceeding further, it will be helpful to define three kinds of "peaks" associated with most ship vibration records and clarify the terminology:

- In each cycle, the "peak" value is the difference between the mean and the greatest value in that cycle. In this guide "peak" will be used in this manner.
- A modulating signal "peaks" every few cycles. To avoid confusion, this guide will refer to this type of peak as a "maximum" value.
- The "peak" spectrum, which is really the spectrum of the greatest rms values in each frequency interval found among several segments. Such values will be called "peak rms" values.

If the "average rms" and "peak rms" values are multiplied by $\sqrt{2}$, spectral single amplitudes, which are called the "average spectral" and "peak spectral" values, are obtained. Sample spectra are given for three different measurements on a ship in Figure 6-5.

There will be some variation in results, depending on the frequency range used. A higher frequency range will involve broader frequency intervals and yield higher results. The differences will be most apparent when the speed of the shaft or machine being measured varies slightly. To eliminate the ill effects of speed variations, some analyzers will track a signal and display the spectrum as harmonic components of the tracked signal.

It is obvious that the average spectral value will always be less than the MRV and the peak spectral values will be closer to the MRV. The exact relationship between the latter two will depend on the rate of modulation compared to the length of the segment. If the modulation is very slow, the amplitude will be near its maximum for the entire length of some segments and the two will be close. If the modulation is fast, the peak will be closer to the average amplitude.

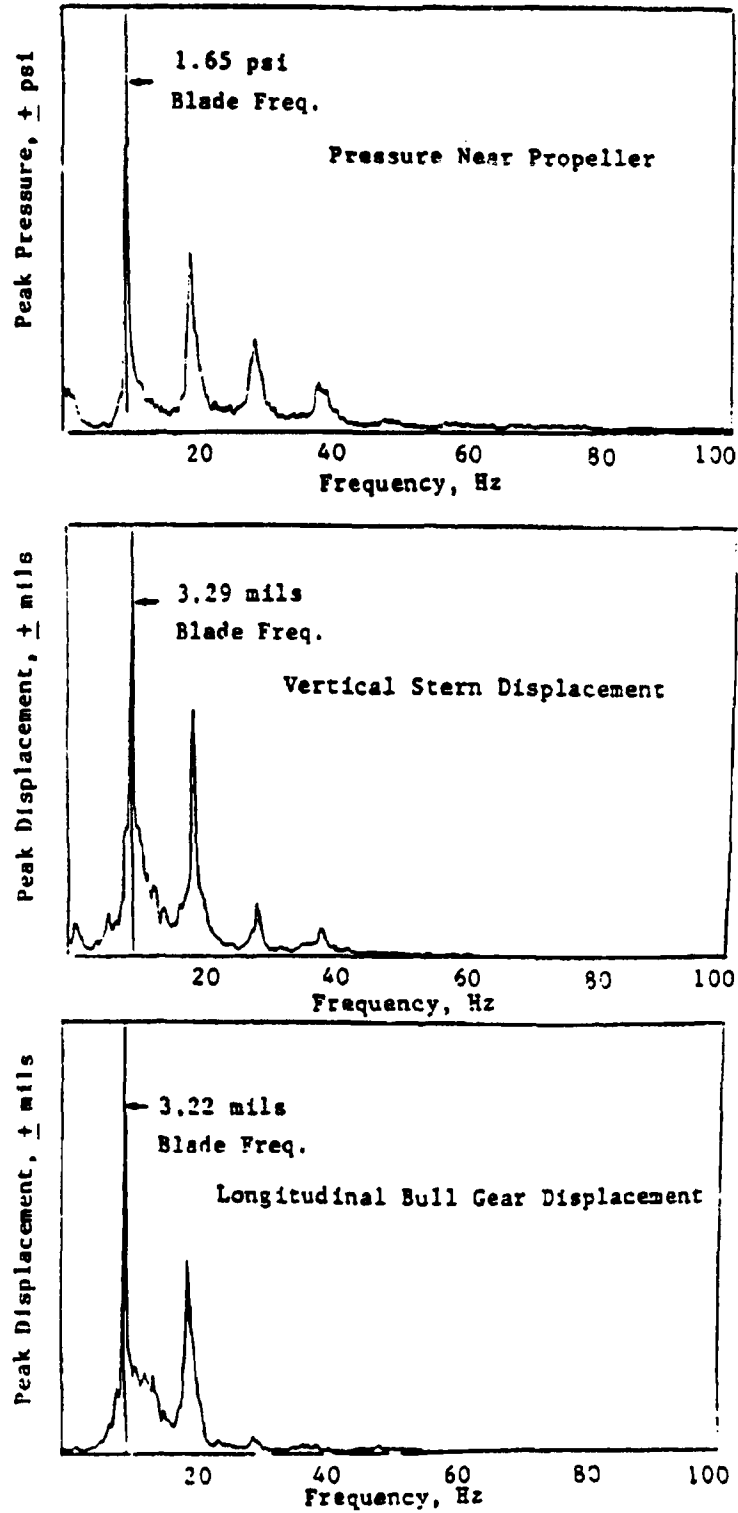

Figure 6-5
Sample Peak Spectra for Various Locations

6.4.4 Histograms of Instantaneous Values

Some analyzers, such as the Nicolet Model 660A Dual Channel Analyzer, sample the signal and obtain histograms of the instantaneous values. This capability might be useful with ship vibration records, but there are several considerations.

First, we are usually concerned with obtaining the amplitudes of the blade or 2 x blade component by itself, so that filtering is necessary as it was for the envelope method. The limitations and corrections discussed in that section apply here also.

Second, we are concerned with the peak amplitudes of the cycles. The histograms are usually obtained by sampling all the points on the record, not just the peaks. The amplitude, which is exceeded by only one or two percent of the samples, would probably involve only the tips of the largest cycles and may be comparable to the MRV. The amplitude, which is exceeded by some percentage of the samples, could be determined from a cumulative probability plot, such as shown in Figure 6-6.

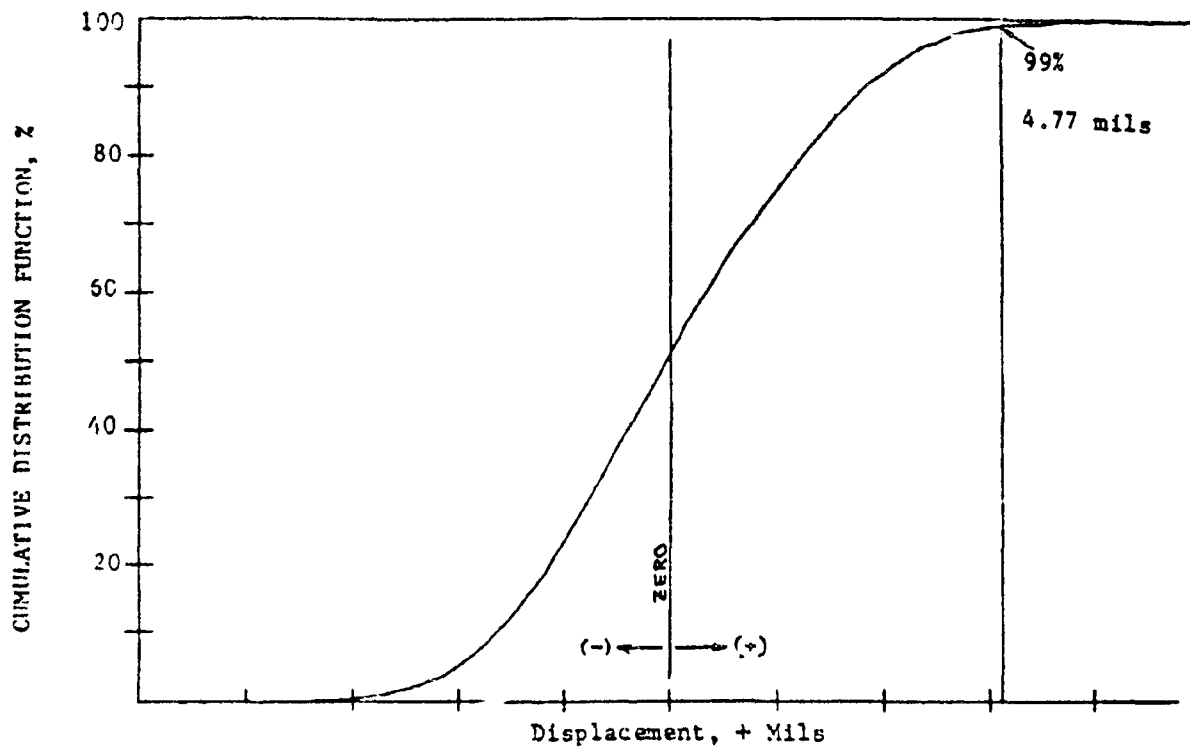

Figure 6-6

Typical Cumulative Distribution Plot with Cursor Set for 99 Percent Probability

6.4.5 Histograms of Peak Values

This procedure would be closer to the envelope method and can be accomplished with an analog to digital (A/D) converter and a microcomputer in conjunction with filters. It entails sampling the filtered signal, as described for histograms of instantaneous values, then finding the peak (and trough) of each cycle. The peak amplitudes are then put into a histogram or cumulative probability plot. The top three, five, or ten percent of the peak amplitudes may be comparable to the MRV. The author is not aware of this procedure being used for routine analysis of ship vibration data, but it would seem to be the most accurate and efficient method of those discussed.

6.4.6 Reporting Formats

The format chosen for reporting data will depend on the purpose of the trials and the type of analysis chosen. For propeller excited vibration the most useful data are usually plots of vibration amplitudes (whether they be maximum repetitive values, average or peak spectral values, or rms amplitudes) versus RPM. This reflects resonances encountered and any ranges of high vibration levels due to things such as cavitation. When frequency spectra are used, there are normally too many to include all of them in a report, but a few well-chosen examples can help in understanding the nature of the data. Data in tabular form is appropriate for the amplitudes measured during maneuvers. Plots of mode shapes, if any were determined, should be included. When the data is to be used for comparison against a given criteria such as ISO 6954, maximum repetitive values are required.

Often measured data is not sufficient to establish accurate mode shapes that may be known from vibration analyses. This is particularly true in the case of machinery torsional mode shapes. Such analyses should be utilized in extrapolating data where possible, with sound judgment exercised regarding the validity of such extrapolations. Data generated in this manner should be annotated to reflect how it was obtained. ISO 4867 [6-5], recommends that reported data include the following:

- The principal ship design characteristics.
- Sketch of inboard profile of hull and superstructure.
- Lines plan of the stern configuration for about one-fifth of the length of the ship.
- Sketch showing locations of hull and machinery transducers. Transducer locations for local vibration measurements should be shown on a separate sketch.
- Trial conditions.
- Curves of maximum repetitive displacement, velocity, or acceleration amplitude versus shaft speed for shaft rotational frequency or blade rate (or machinery excitation frequency) or any harmonic thereof.
- Results of measurements at local areas.
- Results from maneuvers tabulated.
- Results of an anchor drop test including the identified hull natural frequencies and from the decaying vibration traces, the derived damping coefficients. Presentation of oscillograph traces is desirable.

Measurement and Analysis of Shipboard Vibration

- Method of analysis of the results.
- Type of instruments used.
- Hull natural frequencies and modes that have been identified. Also any undesirable or unusual vibration condition encountered.

It is recommended that the ISO Standard 4867 [6-5] be obtained for more complete information on testing requirements.

6.5 Transducer Locations

The locations of transducers chosen will depend on the type of trial being conducted, the type of ship being tested and how thorough a test is desirable. A minimal set of locations for routine sea trials would include:

- Hull Stern
- Thrust Bearing

If there is any suspicion of longitudinal shaft vibration problems, or just to be prudent, the following should be added:

- Main Propulsion System, Longitudinal

When the ship has a large deckhouse aft and when it is located above large holds or machinery spaces with a minimum of transverse or longitudinal bulkheads to support it, the following should be added:

- Deckhouse

If hull girder vibration is a potential problem or if the hull girder excites a local structure the hull modes should be identified:

- Hull Girder

In addition, a problem not associated with the above measurements may have been identified and diagnostic data may be desired. Some comments on the most common problems are included:

- Rotating Machinery
- Resonant Equipment
- Main Propulsion System, Torsional
- Main Propulsion System, Lateral
- Local Structures
- Hull Pressure Forces

Ship Vibration Design Guide

Each of the above is discussed in some detail in this section. Much of the material, particularly for the more routine measurements, is taken from ISO 4867 [6-5]. The standard locations given can often be directly compared to various criteria presented in Chapter Two.

6.5.1 Hull Stern

Vertical, athwartship and longitudinal measurements of the hull girder should be made as close as possible to the centerline and the stern. The steering gear foundation is a recommended location. These measurements should be used for reference purposes. When a torsional response of the hull is to be determined, a pair of deck-edge transducers for vertical vibration should also be employed. It should be ensured that the vibration of the hull girder is measured, excluding local effects.

Normally, velocity gages, integrated to yield displacement, are appropriate for this data. If the lower hull modes are particularly important, accelerometers with low frequency response should be used, perhaps in addition to the velocity gages.

6.5.2 Thrust Bearing

Measurements in three directions (vertical, athwartships and longitudinal) should be made on top of thrust bearing housing. Recording should also be taken on one supplementary point on the thrust block foundation, in the longitudinal direction. Blade and twice blade frequency are of primary concern, making the velocity gage the best transducer for the thrust bearing. Data is usually given in terms of displacement.

6.5.3 Main Propulsion System, Longitudinal

To determine the response of the propulsion shaft system to propeller excitation for steam propulsion plants having a reduction gear system, longitudinal measurements should be made at the following locations as indicated in Figure 6-7:

1. Thrust Bearing Housing. The thrust bearing may be located forward or aft of the reduction gear on the same foundation, or aft on a separate foundation.
2. Thrust Bearing Foundation.
3. Forward End of Bull Gear Shaft. This location can normally be accessed by a probe spring loaded to ride on the shaft center. The transducer is attached to the probe.
4. Gear Case Foundation. On top of the gear case foundation under the shaft centerline.
5. Gear Case Top. Over shaft centerline.
6. High Pressure Turbine. Attached to HP turbine casing at forward or aft end.
7. Low Pressure Turbine. Attached to LP turbine casing at forward or after end.

Measurement and Analysis of Shipboard Vibration

8. Condenser. Mounted as low as practicable and as near the fore and aft centerline as possible.

For diesel propulsion plants, longitudinal measurements should be made as follows:

1. Thrust Bearing Housing. The thrust bearing may be incorporated into the structure of the engine at the aft end or mounted separately.
2. Thrust Bearing Housing Foundation.
3. Main Engine. Top, forward end.
4. Forward End of Engine Crankshaft.

For gas turbines, measurements should be made at the thrust bearing and its foundation, the gear case top and foundation and at the forward end of the bull gear similar to the first five items for steam turbine plants. Again, blade and twice blade frequency are of primary concern and velocity gages, integrated to give displacement, are recommended.

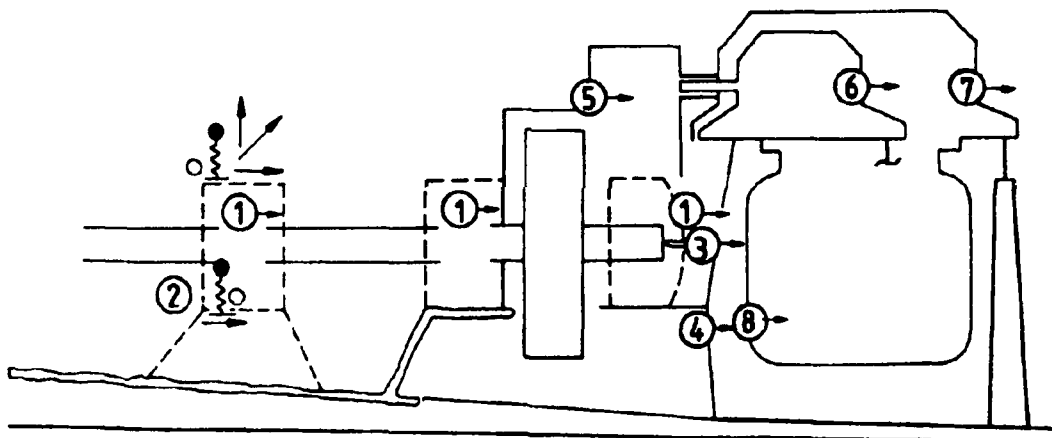

Key

- ① Thrust bearing housing. The sketch shows the three possible positions of the thrust bearing, though the transducer positions are shown for only one.
- ② Thrust block foundation.
- ③ Forward end of bull gear shaft. This position will require a probe and provision for access in the gear case.
- ④ Gear case foundation. On top of the gear case foundation under the shaft centreline.
- ⑤ Gear case top. Over shaft centreline.
- ⑥ High pressure turbine. Attached to h.p. turbine casing at forward or aft end.
- ⑦ Low pressure turbine. Attached to l.p. turbine casing at forward or aft end.
- ⑧ Condenser. Mounted as low as practicable and as near the fore-and-aft centreline as possible.

NOTE - Use propulsion system sketch of ship on which tests were conducted. See figure 2 for symbols.

Figure 6-7

Location of Transducers for Main Engine (Turbine) Vibration [6-5]

6.5.4 Deckhouse

As a minimum, the locations given in ISO 4867 [6-5] should be measured, i.e., vertical, athwartship and longitudinal measurements at the following locations to determine the overall vibration of the superstructure:

1. Wheelhouse, centerline at front of bridge.
2. Main deck, centerline at front of deckhouse.

When torsional vibration is to be determined, include a pair of transducers to measure torsional motions of an aft deckhouse. Normally, deckhouse vibration occurs in the frequency range appropriate for velocity gages.

6.5.5 Hull Girder

Where required to identify lower hull modes, vertical or athwartship amplitudes should be measured on the main deck or strength deck level, as close to the centerline as possible, at a sufficient number of points to permit determining the approximate mode shapes of all measured frequencies. If torsional modes are to be defined, phased deck-edge measurements are required. In all cases, structural "hard spots" should be selected. If instrumentation permits, both a roving pickup and a fixed pickup at the stern should be used to simplify the location of nodes by detecting phase changes and providing relative amplitude data. Even better, if enough transducers are available, all points can be measured simultaneously. Velocity gages can be used except for the lower hull modes, where accelerometers with a low frequency response may be required.

6.5.6 Rotating Machinery

In this section rotating machinery mounted by means of a foundation, which may or may not have resilient mounts and attached to a deck, bulkhead, or the hull itself, will be considered. Excessive vibration may be caused by self-excitation, such as in a rotating machine, or it may be caused by the deck (or whatever the foundation is attached to) vibrating and the machine or equipment being near resonance on that mount.

In order to provide enough information for proper diagnostics, vertical, horizontal (lateral) and longitudinal measurements should be made on the bearing caps of rotating machinery. If the rotor is relatively long, or if the machine consists of two rotors (such as a turbine and a generator) connected by a coupling, measurements should be made at both ends.

Alternatively, if the foundation and casing are known to be very rigid and the motion of the shaft only is of interest, vertical and horizontal (lateral) measurements could be made by proximity probes, if the shaft is accessible and if a suitable mounting can be devised.

For most rotating machinery problems, velocity gages are preferred. Many of the criteria for acceptability are given in terms of velocity levels. For high frequency response, such as in bearing diagnostics, acceleration is better.

6.5.7 Resonant Equipment

If a piece of equipment is resonating on its foundation, it may be oscillating in any or all of the three translation directions and any or all of the three rotational directions. To detect motion in all directions, it is necessary to have six transducers, where pairs, oriented in the same directions, might be used for rotations. To determine all the motions of the deck (or whatever the machine is mounted to) would take another six transducers. Usually, enough is known about the problem, such as the direction of excessive vibration, that some or even most of these can be eliminated. In any case, the resonant condition, whether it be excited by the machine, the equipment itself or by motion of the base, can be easily detected by the relative motion between the equipment and its base.

The frequencies encountered in resonant situations are normally in the range of velocity gages. Often displacement signals are best for these cases.

6.5.8 Torsional Vibration

If torsional measurements are to be made, it should be done with a thorough knowledge of the expected natural frequencies and mode shapes. This is true because of two factors. First, the number of locations to make torsional measurements is usually very limited and the most has to be made of what is available. Second, the mass and stiffness characteristics in the torsional direction are usually amenable to accurate determination, making the prediction of natural frequencies and mode shapes reasonably reliable. Hence, a measured quantity at one location can be extrapolated by means of these predictions to obtain displacements or stresses at other locations. While this procedure can get complicated and normally requires a vibration engineer, *there are several general points that can be provided for guidance.*

The two types of measurements generally available are torsional motion (displacement, velocity or acceleration) and torsional strain. If motion is to be measured by means of a torsion meter it must be mounted on the end of a shaft on its centerline or mounted on an auxiliary shaft driven by a belt off the main shaft. An alternative is to mount an accelerometer or velocity gage to the shaft in a tangential direction. Torsional displacements are preferred to velocities or accelerations because they can more readily be related to stress. Torsional strain can be measured by means of strain gages mounted to the shaft.

Whatever locations are chosen, they should have relatively high amplitudes as indicated by the calculated mode shapes for the modes that fall within the frequency range of interest. This will minimize errors in the extrapolation process.

6.5.9 Main Propulsion System, Lateral

Lateral measurements are determined by the type of problems encountered and the type of equipment involved. It is difficult to generalize as far as transducer locations are concerned. The locations shown in Figure 6-8 are recommended in ISO 4867 [6-5].

For lateral vibration of the shaft, vertical and athwartships vibration measurements should be made on the shaft relative to the stern tube. These may also be taken relative to line shaft bearings. In order to eliminate possible error, shaft run-out should be checked by rotating the

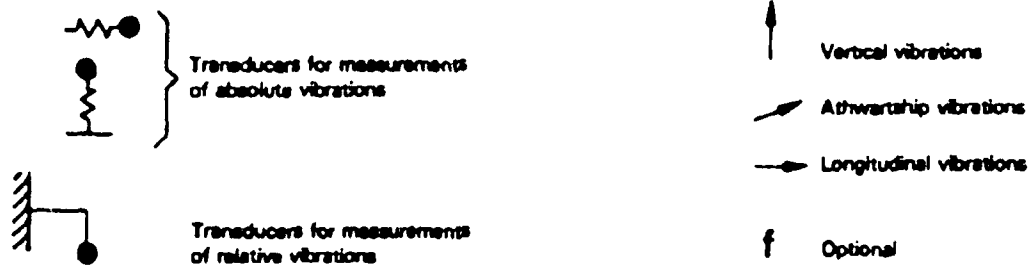
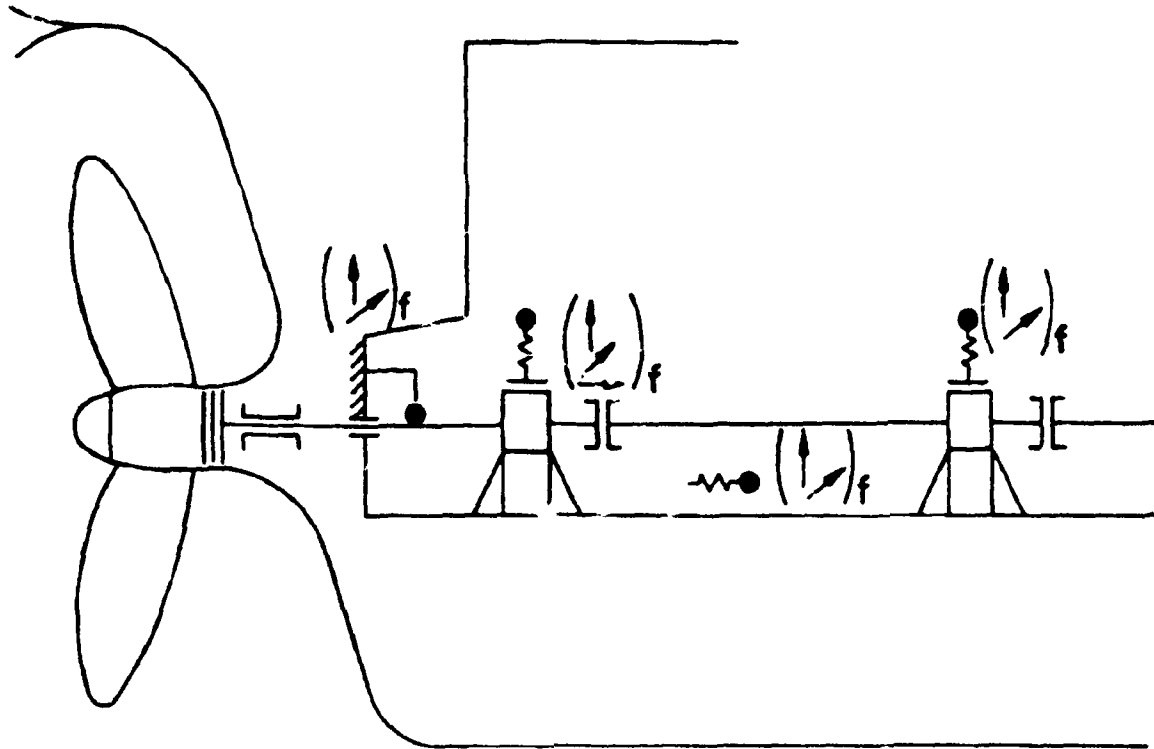

Figure 6-8

Location of Transducers for Vibration of Aft End of Line Shafting

shaft with the turning gear and recording the first-order signal. This signal should be phased and the shaft vibration measurement corrected accordingly. For lateral vibration of turbines and gears, see Section 6.5.6 Rotating Machinery.

For lateral vibration of direct-drive diesel engines, vertical and athwartships measurements on the top, forward and aft ends, of the main engine are required as a minimum. Vertical and athwartships measurements are also recommended on the forward and aft ends of the engine foundations as illustrated in Figure 6-9.

Measurement and Analysis of Shipboard Vibration

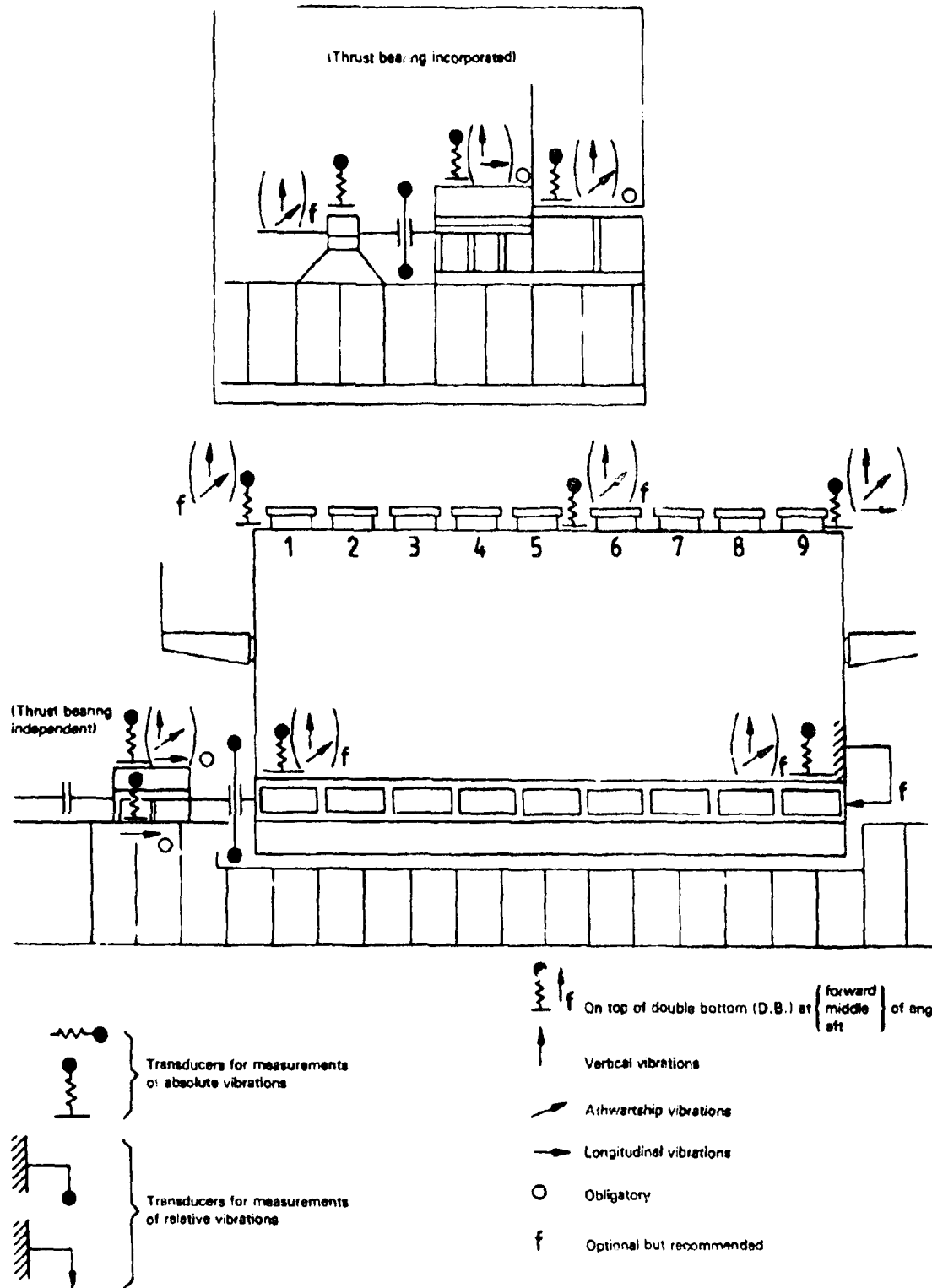

Figure 6-9

Location for Transducers for Main Engine (Direct-Drive Diesel) Vibration [6-5]

6.5.10 Local Structures

The discussion for resonant equipment is applicable to this section as well. The only thing that can be readily added is a reminder that if the local structure that seems to be a problem is not a rigid body supported by a foundation but is instead a flexible member in which a part is vibrating excessively, then the natural frequencies and mode shapes of that structure must be studied with enough transducers to define its mode shapes.

6.5.11 Hull Pressure Forces

If the measurement of hull pressure forces is required to confirm design estimates, to obtain design data or to investigate potential cavitation problems, the pressure transducers should be located as shown in Figure 6-10.

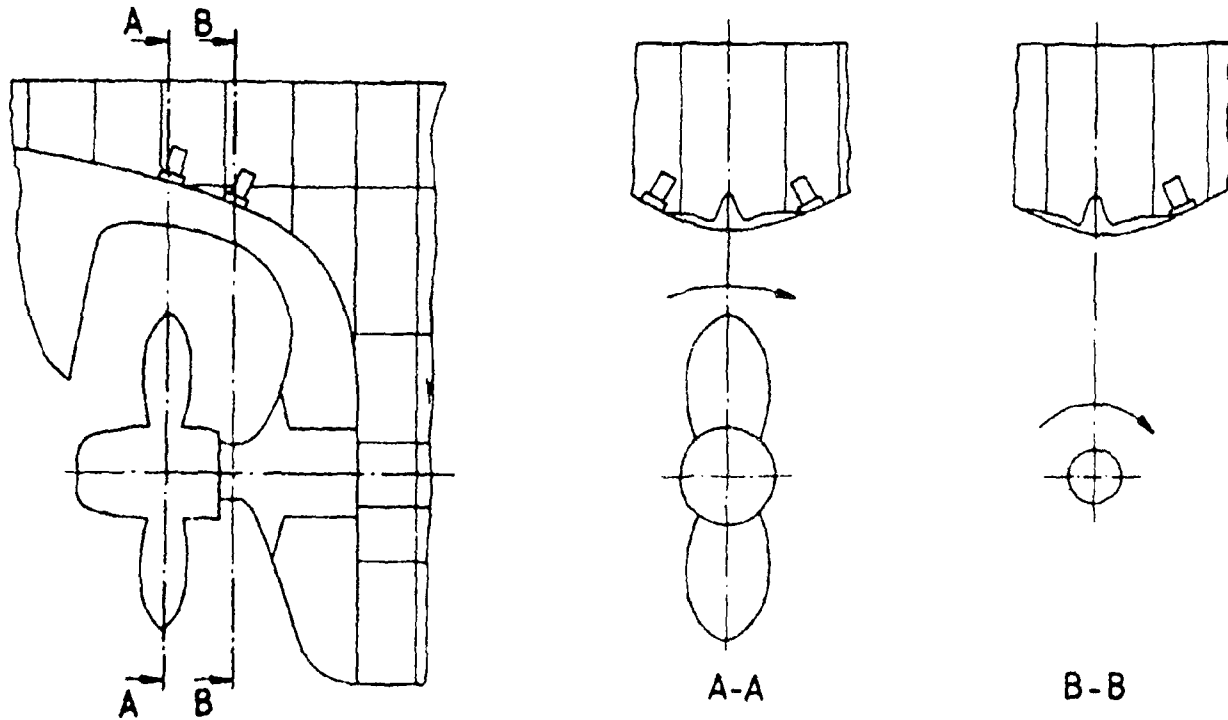

Figure 6-10

Location of Pressure Transducers [6-5]

6.6 Test Conditions

In order to obtain ship vibration data that can be evaluated against existing standards, measurements should be made during uniform test conditions. The discussion of the factors affecting vibration levels and the recommended test conditions are excerpted from ISO 4867 [6-5].

The relatively uniform vibration resulting from propulsion machinery excitation (turbine or diesel drive) can be masked or distorted by transient vibrations due to wave impact or slamming. Changes in wake distribution due to rudder angle and yaw can produce large increases in exciting forces. Operation in shallow water also has a significant effect on hull vibration. Propeller emergence, whether continuous or periodic, causes large increases in exciting forces.

In view of the above, the following test conditions are recommended:

- The test should be conducted in a depth of water not less than five times the draft of the ship.
- The test should be conducted in a quiet sea, generally State 3 or less.
- The ship should be ballasted to a displacement as close as possible to the operating conditions. The draft aft should insure full immersion of the propeller.
- During the free-route portion of the test, the rudder angle should be restricted to about 2 degrees port or starboard (minimum rudder action is desired).

6.7 Test Procedures

For any test, the first step is to calibrate the recording equipment. If ship control is involved, communications must be set up. The procedures for taking data are discussed for tests involving ship control (Hull and Main Propulsion System) and those involving auxiliary machinery. Other tests may require different procedures.

6.7.1 Calibration Procedures

Calibration procedures are categorized as system calibration or electrical calibration. In general, system calibration refers to a procedure that is done before installing instrumentation on board ship, or as the transducers are installed. It should be a complete reckoning of the sensitivity of the transducers, signal conditioning and recording equipment.

Electrical calibration refers to a procedure that can be accomplished usually at the recording center, is considered a "spot check," takes only a few minutes, and can be done periodically during the vibration trials. Calibration procedures are different for different types of gages and are discussed in this section.

6.7.1.1 Accelerometers

All accelerometers can be calibrated over the frequency range of interest by mounting on a shaker table or calibration device that is oscillating at known amplitudes. Normally, this is the type of system calibration that is used. Strain gage and piezoresistive accelerometers can be calibrated for zero, $\pm 1g$ by laying them on their sides, their bases and upside down, respectively. This provides a D.C. calibration only and is useful only if the conditioning and recording equipment operates at a frequency of zero Hz.

Once the transducers are installed, the "electrical calibration" is usually accomplished by an internal (to the amplifier) signal of known value being applied to the conditioning and recording equipment. In the case of strain gage and piezoresistive accelerometers, a shunt resistor can be applied across one arm of the bridge and the value of the resistor can be equated to a certain acceleration. The latter results in a D.C. step being recorded.

6.7.1.2 Velocity Gages

System calibration for velocity gages should be done on a shaker table that oscillates at known amplitudes and frequencies. There are no D.C. types of calibration suitable for these gages. Electrical calibration is done by means of an internal signal of known value being fed into the conditioning and recording equipment. Since the conditioning equipment usually does not operate for D.C. signals, the known signal is normally a sinusoid.

6.7.1.3 Proximity Probes

Proximity probes should not be sensitive to changes in frequency and therefore can be calibrated for D.C. steps only. They should be calibrated at several distances from the target by means of "feeler" gages. Plastic feeler gages are available that do not affect the signal and can be left in place while recording. Preliminary calibration can be done before installing the probes on board ship, but the final calibration should be done with the probes in place because each target has a slightly different effect on the gage. The only practical type of "electrical" calibration would be the substitution of a signal of known value.

6.7.1.4 Strain Gages

The type of calibration used with strain gages will depend on how they are used. Again the signal output should not be sensitive to frequency and D.C. calibrations are adequate. If possible, the strain gaged object should be subjected to known loads and the resulting strains calculated and related to the signal output. If the object has a complex shape or if known loads are difficult to apply, the only choice is to accept the manufacturers listed Gage Factor and use a shunt resistor for calibration.

In most applications on board ship, the signal leads from the strain gages are fairly long. This reduces the sensitivity of the gages, requiring the shunt to be applied at the gage rather than at the amplifier to obtain accurate results.

6.7.2 Communications

The trial director, who should be stationed at the recording center, should have communications by sound powered phones, hand-held VHF radios or other means with the bridge or the engine control center, whoever is controlling the course and speed of the ship. Whoever is on the phones at the controlling station should have access to RPM gages and a rudder indicator and be able to advise the trial director immediately of any changed conditions. Often the trial director will station himself and his equipment in a space where that information is available directly.

6.7.3 Hull and Main Propulsion System Vibration

ISO 4867 [6-5] and SNAME Code C-1 [6-2] give test procedures for gathering data on hull and main propulsion system vibration in commercial ships:

- a. Make a steady deceleration or acceleration run of, preferably, less than 5 RPM per minute to determine location of critical speeds.

NOTE: These runs do give an indication of critical speeds, but if the change in shaft speed, which is hard to control, is uneven when the propeller is loaded it may give a false indication of resonance. Also, the amplitudes cannot be trusted since steady-state conditions have not been established and only a small sample is considered at each speed.

- b. In free route, run from half shaft speed to maximum speed at increments of 3 to 10 RPM. Additional runs at smaller increments are required in the vicinity of critical speeds and near-service speed.
- c. Hard turns to port and starboard at maximum speed (optional).
- d. Crashback from full power ahead to full power astern (optional).
- e. Anchor drop-and-snub (optional).

For steady speed free-route runs, permit ship to steady on speed. Hold at steady speed for a sufficient time to permit recording of maximum and minimum values (about one minute). In multiple shaft ships, all shafts should be run at, or as close as possible to the same speed to determine total vibration amplitudes. In certain instances, it may be preferable to run with a single shaft when determining vibration modes.

NOTE: A one minute record length was recommended with oscillographic analysis in mind. For electronic analysis, which is less time consuming, two to three minutes is recommended.

For maneuvers, start the recorder as the throttle or wheel is moved. Allow to run until maximum vibration has passed. This normally occurs when the ship is dead in the water during a crashback maneuver or when the ship is fully in a turn.

Ship Vibration Design Guide

For the anchor drop-and-snub test, the anchor must fall freely and be snubbed quickly by use of the windlass brake and must not touch bottom. The ship must be dead in the water for this test, with a minimum of rotating equipment in operation. Care must be taken not to exceed the recommendations for free drop as indicated by the manufacturer of the anchor windlass. Data should be taken continuously from the moment the anchor is released until vibration can no longer be detected.

6.7.4 Auxiliary Machinery

ISO 4868 [6-6] and SNAME Code C-4 [6-3] give test procedures for gathering data on local shipboard structures and machinery. When evaluating the vibration of auxiliary machinery, the following guidelines are recommended:

- For constant speed units, measurements should be made at the rated speed.
- For variable speed units, measurements should be made at about five equally spaced points in the operating speed range, including known criticals.
- For multi-speed units, measurements should be made at each operating speed.
- To minimize interference, as much nearby equipment as possible should be shut down.

NOTE: To familiarize personnel with the measurement of shipboard vibration, the simple mechanical instruments referred to in Section 6.2.1 are recommended. As a next step, instrument packages are available, which include a transducer, tunable filter and calibrated meter, as discussed in Section 6.2.4.1. For more complex studies, including ship trials, the instrumentation system described in SNAME Code C-1 is recommended. This version of shipboard vibration instrumentation is maintained by the Maritime Administration and, under special conditions, may be borrowed from MARAD.

6.8 General Comments and Recommendations

In the application of vibration technology, we are necessarily concerned with its measurement and analysis, whether it is related to machines, vehicles or structures. We may be concerned with stresses in machines and structures; with performance requirements for equipment; and with environmental vibration levels related to habitability. To do so effectively in design and/or evaluation, it is of primary importance that we clearly establish standards to be used for measurement and evaluation that are suitable for the many individually established requirements and criteria.

The vibration standards developed for shipboard application by the ISO are probably among the most complex, partially due to the strong signal modulation that exists aboard ship. A second problem area arises in the measurement and analysis technology due to the more recent developments of instrumentation, particularly with the preferred usage of the fast Fourier transform (FFT), which provides a convenient and efficient measurement technique but,

unfortunately, does not accurately generate the required quantification of the vibration signal. A third problem relates to the availability of alternate measurement systems, each of which may produce answers that may not agree with the others. This in turn is complicated by the necessity (for legal reasons) of avoiding the specification of any particular instrument package and the tendency of those making the measurements to adjust to the convenience of the instrumentation, rather than the requirements of the standards.

6.8.1 General Comments on Instrumentation

In this section, general comments on the measurement and analysis procedures discussed in this chapter will be given and recommendations will be presented for current use. At the time the ISO Standards, 4867, 4868 and 6954 [6-5], [6-6] and [6-7] respectively, were developed, the quantity to be measured and evaluated was the maximum repetitive amplitude (MRA) of the particular frequencies involved. The MRA is specified in these standards but little information was included on the measurement and analysis of shipboard vibration, since it is inappropriate to specify the particular instrumentation to be used. It was recognized, however, that many investigators preferred to use the FFT type analyzer, which automatically produced a spectral analysis similar in nature to that required, but unfortunately, did not provide the MRA as called for. To compensate for this deficiency, a note was included in ISO 6954, which states:

NOTE: The measurement procedures defined in ISO 4867 and ISO 4868 form the basis of the curves shown in the figure and it is intended that this International Standard is interpreted accordingly. However, time averaged rms values are often measured instead of maximum repetitive values. In such cases, the bandwidth and time-averaging period should be specified and the rms values converted by using the conversion equation given below, to the equivalent maximum repetitive values for comparison with the figure. The appropriate conversion factor, C_F , should either be determined by measurement or assumed to have the tentative value $C_F = 1.8$.

$$\text{Maximum repetitive value} = (C_F \sqrt{2}) \times \text{rms value}$$

where:

$C_F \sqrt{2}$ is equivalent to the crest factor

($C_F = 1.0$ implies pure stationary sinusoidal vibration)

The Annex to ISO Standard 6954 also states:

Shipboard vibration generally approximates to narrow-band vibration and a crest factor of 2.5 is commonly encountered. In these circumstances, the maximum repetitive vibration is more appropriate than rms value with regard to evaluation of overall ship vibration.

This International Standard evaluates overall shipboard vibration in terms of maximum repetitive values and, for comparison with rms values, the crest factor shall be taken into account.

Ship Vibration Design Guide

Section 6.4 provides more detailed information on six alternate methods of measurement and analysis, which currently could be used. As pointed out in [6-8], whatever equipment is used should produce the same result. However, experience has shown [6-10] that considerable variation in shipboard test results have been encountered due to improper use of the FFT analyzer or omission of the appropriate crest factor.

As an indication of how the envelope, spectral and statistical methods of analysis compare, these three methods were used to analyze the following three measurements, taken from a real-time tape recording obtained on a LNG ship trial with measurements made at four shaft speeds.:

- Pressure on hull near propeller
- Vertical stern displacement
- Longitudinal bull gear displacement

The envelope method was performed with the following equipment:

- Racal Store-4 (4 channel) FM Tape Recorder
- One or two Krohn-Hite Model 3550 Variable Filters
- Gould 220 2-channel Strip Chart Recorder

The spectral analysis was done with the following:

- Racal Store-4 (4 channel) FM Tape Recorder
- Nicolet Model 446A Single Channel Analyzer
- Nicolet Model 136A Digital Plotter

The statistical method was done with the following:

- Racal Store-4 (4 channel) FM Tape Recorder
- One or two Krohn-Hite Model 3550 Variable Filters
- Nicolet Model 660A Dual Channel Analyzer
- Nicolet Model 136A Digital Plotter (if hard copy desired)

The results are shown on Figure 6-11 for easy comparison. The average conversion factor, C_F , is approximately 1.8 for the three locations shown, with that for the Pressure measurement about 1.5 and the Stern Vertical about 2.0. It is obvious, however, that the Peak Spectra, the quantity frequently reported, is substantially lower than the Envelope value, which is considered the "true" value.

Measurement and Analysis of Shipboard Vibration

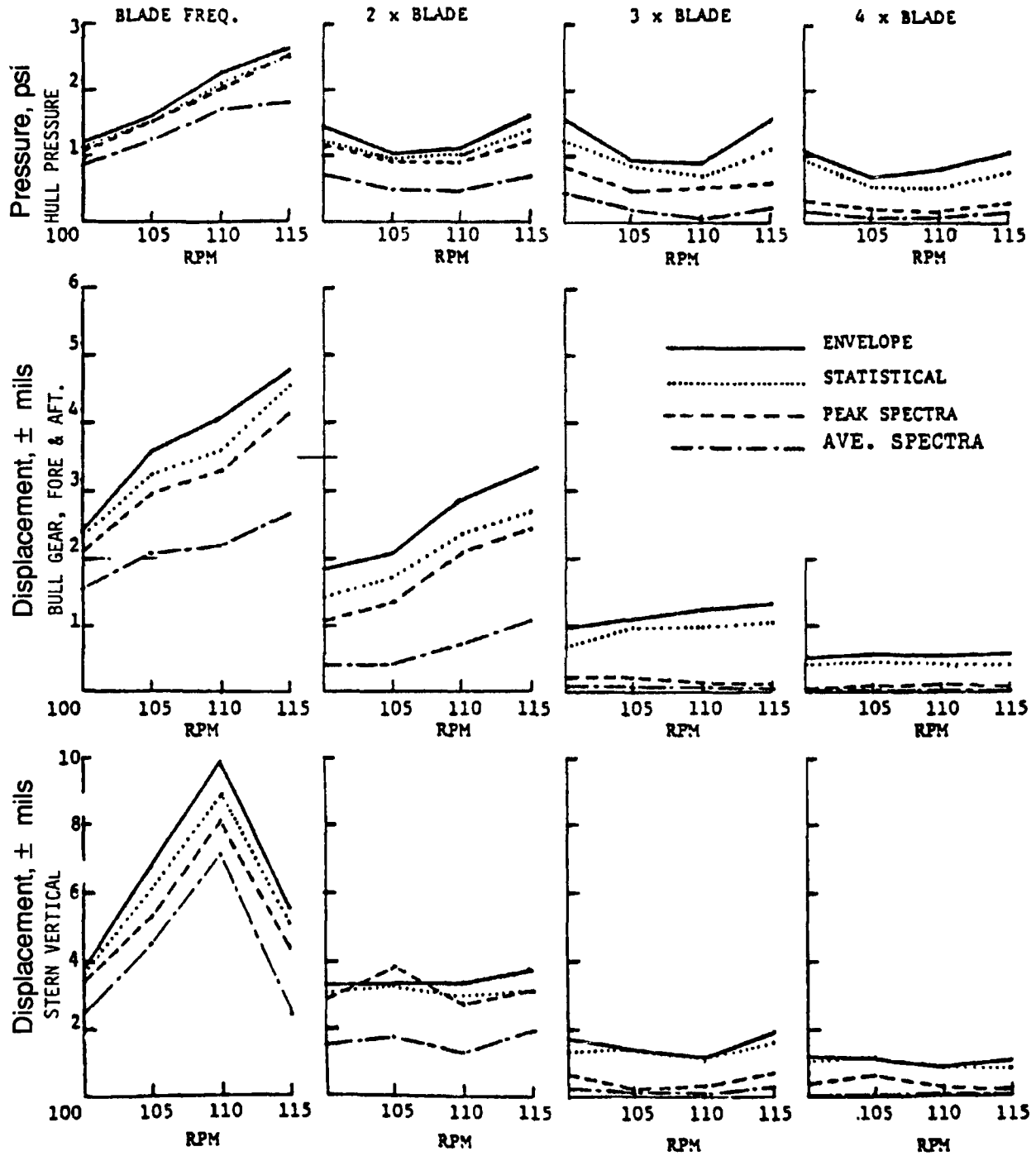

Figure 6-11

Comparison of *El Paso Savannah* Data Analyzed with Different Methods

Ship Vibration Design Guide

Originally, the statistical and envelope analyses produced results that were in error due to filter characteristics. The amount of error varied according to the proportions of 1st, 2nd, 3rd and 4th harmonics. Using the proportions from the peak spectra, the errors were calculated and are given in Table 6-3. The errors associated with blade frequency and 2 filters is small and no correction was made. A 10% correction was made for blade frequency (1 filter) and 2 x blade frequency (2 filters).

Table 6-3 Filter Induced Errors

Component	Number of Filters	Pressure	Stern	Bull Gear	Average
Blade	2	1.2%	1.7%	1.4%	1.4%
Blade	1	10.5%	11.4%	9.1%	10.3%
2 x Blade	2	17.4%	9.1%	7.3%	11.2%

It was expected that the statistical and envelope results would be unacceptable for the 3rd and 4th harmonics, but those quantities were obtained solely for comparison purposes. As expected, they are much higher than the spectral results.

Examination of Figure 6-7 indicates that the ratios between the various methods vary with the location of measurement and the harmonic involved. The development of "crest factors" would have to account for these parameters as well as sea state, which is known to effect the modulation of ship vibration. The levels of the 3rd and 4th harmonic are low enough to ignore, except perhaps for the pressure measurements. Generally speaking, the 3rd, 4th, etc. harmonics can be minimized in the propeller design, thus rendering these harmonics to be of no consequence.

Differences were also noted in the peak spectral values obtained with the Nicolet analyzer and similar quantities reported by others on the same tape. This factor may be related to the ratio between the obtained maximum value and the weighted rms values obtained by the alternate analyzers, which in turn relates to the integration time employed by the respective instruments. Some experts suggest an integration time of one or two seconds, if standardized, would produce a peak value that would approximate the MRA. However, as the frequency increases, the resulting sample would necessarily average a greater number of vibratory cycles and thus increase the difference between the averaged peak value and the MRA.

The ISO Ship Vibration Working Group is continuing to investigate alternate means of minimizing the discrepancy in the use of the spectral analyzer. In this regard, most ISO member countries are continuing their investigations. Unfortunately, however, there is no current support in the USA, or in the U.S. Navy, where such development programs on shipboard vibration have traditionally been carried out.

6.8.2 Recommendations

At this time, specific interim recommendations for the measurement and evaluation of shipboard vibration are included as follows:

1. Oscillographic recording and manual analysis of real-time records, such as obtained by the current MARAD equipment, will produce the required MRA and can be used effectively.
2. As an improvement on the MARAD system to take advantage of the automatic analysis features of the FFT Analyzer, it is recommended that the real-time data be recorded on tape for more detailed analysis to be carried out after the tests, if required. Individual channels of required data can be obtained on an oscillograph to obtain "quick-look" results aboard ship, as necessary, to satisfy specification requirements. The "Envelope" method of analysis of the tape, should be employed to obtain the "true" MRA. The tapes should be retained for further use, either for resolving unanswered questions and/or for the development of a ship vibration data bank.
3. For the direct use of the spectral analyzer for satisfying the requirements of ISO Standards, it is recommended that the average rms values $\times \sqrt{2}$ be recorded and the results multiplied by the conversion factor C_F 1.8, as specified in ISO 6954. In sample studies carried out by the ISO Ship Vibration Working Group members in 1986, very good agreement was obtained on the analysis of a common tape, when the average rms was evaluated. This basis would provide consistency in results, although, to obtain the "true" MRA data, it would also be necessary to use the "Envelope Method" of analysis to obtain the required crest factors.
4. When using test data to confirm design predictions, consideration should be given to the use of the average rms value $\times \sqrt{2}$ for comparison with the sinusoidal input used in design predictions. As was previously suggested in [6-8], this could be readily accomplished by dividing the ISO criteria of 9mm/sec by the average conversion factor, C_F of 1.8, and use the resulting limit of 5 mm/sec for direct comparison with the calculated hull response predictions. It is also recommended that this approach be investigated in more detail before adoption.
5. A research project should be established to develop improvements in the alternate techniques currently available in the measurement and analysis of shipboard vibration.
6. Vibration generators may be effectively used for collecting shipboard vibration data, particularly prior to the trial voyage. Details of the sinusoidal (sweep-sine) and transient tests [6-11] are included as Appendix 6-A.

REFERENCES

- 6-1 "Code for Shipboard Hull Vibration Measurements," SNAME T & R Bulletin Number 2-10, June 1964.
- 6-2 "Code for Shipboard Vibration Measurements," SNAME T & R Code, C-1, January, 1975.
- 6-3 "Shipboard Local Structures and Machinery Vibration Measurements," SNAME T & R Code C-4, 1976.
- 6-4 "Shipboard Vibration and Noise Guidelines," SNAME T & R Bulletin 2-25, January, 1980.
- 6-5 International Standard, ISO 4867, "Code for the Measurement and Reporting of Shipboard Vibration Data," December 1, 1984.
- 6-6 International Standard, ISO 4868, "Code for the Measurement and Reporting of Local Vibration Data of Ship Structures and Equipment," November 15, 1984.
- 6-7 International Standard, ISO 6954, "Mechanical Vibration and Shock-Guidelines for the Overall Evaluation of Vibration in Merchant Ships," December 15, 1984.
- 6-8 Noonan, E. F., "On the Use of Shipboard Vibration Standards," Document ISO/TC 108/SC 2/WG 2 N 59, March 1987.
- 6-9 Manley, R. G., "Waveform Analysis," John Wiley and Sons, Inc. (1946).
- 6-10 NKF Report No. 7702-05-01, "Evaluation of Analysis Methods for Shipboard Vibration Measurements," June 5, 1980.
- 6-11 Ramsey, K.A., "Effective Measurements for Structural Dynamics Testing," Sound and Vibration, April, 1976.

APPENDIX 6-A

Vibration Generator Tests

For gathering data on shipboard vibration, the test procedures of ISO 4867 and SNAME Code C-1 are recommended. In addition to the procedures indicated, two other mechanical excitor-based tests, useful for collecting shipboard vibration data, particularly prior to the trial voyage, are also recommended. These are the transient and sinusoidal (sweep-sine) tests summarized for reference as follows:

I. Sweep-Sine Test

1. Tools and Equipment:

(a) Electro - Mechanical Excitor

- weighs 500-2,000 kg
- welded or bolted to a ship's main structure member near propeller
- produces controllable harmonic oscillating force (e.g. reaching 20 tonnes at 14 Hz at maximum) due to a rotating out-of-balance weight
- force direction can be changed from the vertical to the horizontal direction by switching the position of rotating out-of-balance weight

(b) Transducers - used to pick up vibration response

2. Application:

The excitation induced by the excitor is similar to a hull surface force, which is in the range of 15-50 tonnes at 6-12 Hz for large ships. Thus, the excitor will produce a forced vibration of the whole aftbody and superstructure similar to that induced by the hull surface force.

3. Limitation and disadvantage:

- Utilization for the test frequencies below 4-5 Hz is limited when rotating out-of-balance weights are used.
- Time consuming
- Can cause beat phenomena resonance of the main structure to which the excitor is welded or bolted.

II. Impact Test

1. Tools and Equipment:

- a) Hammer - 35kg in weight used to produce impact forces whose duration and shape are affected by the flexibility of the rubber cushion between the hammer and impacted structure.
- b) Load Cell - used to record the force pulse
- c) Accelerometers - used to record transient vibration response at a number of selected positions.

2. Application:

Producing transient vibration of a superstructure. The heavy hammer typically impact the front wall between some of higher decks (say, navigation and compass decks) and near the side wall of the structure to excite all superstructure vibration modes at the same time. Force and vibration response versus time are recorded for a 15-20 second interval beginning with the hammer hits the structure. The test is also appropriate for examining superstructure damping.

3. Limitation:

The test is generally not feasible for the hull girder.

COMMITTEE ON MARINE STRUCTURES

Commission on Engineering and Technical Systems

National Academy of Sciences - National Research Council

The COMMITTEE ON MARINE STRUCTURES has technical cognizance over the interagency Ship Structure Committee's research program.

Stanley G. Stiansen (Chairman), Riverhead, NY
Mark Y. Berman, Amoco Production Company, Tulsa, OK
Peter A. Gale, Webb Institute of Naval Architecture, Glen Cove, NY
Rolf D. Glasfeld, General Dynamics Corporation, Groton, CT
William H. Hartt, Florida Atlantic University, Boca Raton, FL
Paul H. Wirsching, University of Arizona, Tucson, AZ
Alexander B. Stavovy, National Research Council, Washington, DC
Michael K. Parmelee, Secretary, Ship Structure Committee,
Washington, DC

LOADS WORK GROUP

Paul H. Wirsching (Chairman), University of Arizona, Tucson, AZ
Subrata K. Chakrabarti, Chicago Bridge and Iron Company, Plainfield, IL
Keith D. Hjelmstad, University of Illinois, Urbana, IL
Hsien Yun Jan, Martech Incorporated, Neshanic Station, NJ
Jack Y. K. Lou, Texas A & M University, College Station, TX
Naresh Maniar, M. Rosenblatt & Son, Incorporated, New York, NY
Solomon C. S. Tam, Oregon State University, Corvallis, OR

MATERIALS WORK GROUP

William H. Hartt (Chairman), Florida Atlantic University, Boca Raton, FL
Fereshteh Ebrahimi, University of Florida, Gainesville, FL
Santiago Ibarra, Jr., Amoco Corporation, Naperville, IL
Paul A. Lagace, Massachusetts Institute of Technology, Cambridge, MA
John Landes, University of Tennessee, Knoxville, TN
Jamdouh M. Salama, Conoco Incorporated, Ponca City, OK
James M. Sawhill, Jr., Newport News Shipbuilding, Newport News, VA

SHIP STRUCTURE COMMITTEE PUBLICATIONS

- SSC-333 Advance Methods for Ship Motion and Wave Load Prediction by James C. Oliver, 1989
- SSC-334 Influence of Weld Porosity on the Integrity of Marine Structures by William J. Walsh, Brian N. Leis, and J. Y. Yung, 1989
- SSC-335 Performance of Underwater Weldments by R. J. Dexter, E. B. Norris, W. R. Schick, and P. D. Watson 1986
- SSC-336 Liquid Sloshing in Cargo Tanks by N. A. Hamlin 1986
- SSC-337 Part 1 - Ship Fracture Mechanisms Investigation by Karl A. Stambaugh and William A. Wood 1987
- SSC-337 Part 2 - Ship Fracture Mechanisms - A Non-Expert's Guide for Inspecting and Determining the Causes of Significant Ship Fractures by Karl A. Stambaugh and William A. Wood 1987
- SSC-338 Fatigue Prediction Analysis Validation from SL-7 Hatch Corner Strain Data by Jen-Wen Chiou and Yung-Kuang Chen 1985
- SSC-339 Ice Loads and Ship Response to Ice - A Second Season by C. Daley, J. W. St. John, R. Brown, J. Meyer, and I. Glen 1990
- SSC-340 Ice Forces and Ship Response to Ice - Consolidation Report by C. Daley, J. W. St. John, R. Brown, and I. Glen 1990
- SSC-341 Global Ice Forces and Ship Response to Ice by P. Minnick, J. W. St. John, B. Cowper, and M. Edgecomb 1990
- SSC-342 Global Ice Forces and Ship Response to Ice - Analysis of Ice Ramming Forces by Yung-Kuang Chen, Alfred L. Tunik, and Albert P-Y Chen 1990
- SSC-343 Global Ice Forces and Ship Response to Ice - A Second Season by P. Minnick and J. W. St. John 1990
- SSC-346 Fatigue Characterization of Fabricated Ship Details - Phase 2 by K. K. Park and F. V. Lawrence, Jr. 1988
- SSC-349 Development of a Generalized Onboard Response Monitoring System (Phase I) by F. W. DeBord, Jr. and B. Hennessy 1987
- None Ship Structure Committee Publications - A Special Bibliography 1983