

2

REPORT DOCUMENTATION PAGE

Form Approved  
OMB No. 0704-0188

1. REPORT SECURITY CLASSIFICATION  
Unclassified

2. SECURITY CLASSIFICATION AUTHORITY  
DTIC ELECTED FEB 15 1991  
3. DISTRIBUTION / AVAILABILITY OF REPORT  
Approved for public release; distribution is unlimited.

4. MONITORING ORGANIZATION REPORT NUMBER(S)  
AFOSR-TR-91-0012

5. OFFICE SYMBOL (if applicable)  
6. ADDRESS (City, State, and ZIP Code)  
California Institute of Technology  
Pasadena, CA 91125

7. NAME OF MONITORING ORGANIZATION  
AFOSR/NA  
7b. ADDRESS (City, State, and ZIP Code)  
Building 410, Bolling AFB DC  
20332-6448

8. NAME OF FUNDING / SPONSORING ORGANIZATION  
AFOSR/NA  
8b. OFFICE SYMBOL (if applicable)  
9. PROCUREMENT INSTRUMENT IDENTIFICATION NUMBER  
F49620-86-c-0113

10. SOURCE OF FUNDING NUMBERS  
PROGRAM ELEMENT NO. 61103D  
PROJECT NO. 3484  
TASK NO. A1  
WORK UNIT ACCESSION NO.

11. TITLE (Include Security Classification)  
U) Investigations into Shock-induced Enhancement of Mixing and Combustion in Supersonic Burners

12. PERSONAL AUTHOR(S)  
Frank E. Marble

13. TYPE OF REPORT  
Final Report  
13b. TIME COVERED  
FROM 10/1/86 TO 9/30/90  
14. DATE OF REPORT (Year, Month, Day)  
11/30/90  
15. PAGE COUNT  
21

16. SUPPLEMENTARY NOTATION

17. COSATI CODES  
18. SUBJECT TERMS (Continue on reverse if necessary and identify by block number)  
Supersonic Combustion Scramjet Vortex Shock Baroclinic

19. ABSTRACT (Continue on reverse if necessary and identify by block number)  
Experiments were carried out in the CALCIT 17" shock tube to investigate the effectiveness of shock enhancement on the mixing rate of a cylinder of helium gas into the surrounding air. Laser induced fluorescence was employed to trace the time development of mixing using byacetal dye to mark the helium. The concentration of helium was reduced below 20% of its initial value over 0.6 of the helium volume within less than one ms by a weak (M=1.1) shock. The results corresponded well to results of computational analysis. Details of the combustion within the vortex were investigated in large vortices, created by a pulsing technique in the Unsteady Combustion Facility. The results of this program were sufficiently promising to encourage the design, construction and test of a scramjet injector using the technique.

91 2 12 087

20. DISTRIBUTION / AVAILABILITY OF ABSTRACT  
 UNCLASSIFIED/UNLIMITED  SAME AS RPT  DTIC USERS  
21. ABSTRACT SECURITY CLASSIFICATION  
Unclassified  
22a. NAME OF RESPONSIBLE INDIVIDUAL  
Julian M Tishkoff  
22b. TELEPHONE (Include Area Code)  
(202) 767-0465  
22c. OFFICE SYMBOL  
AFOSR/NA

## FINAL REPORT

### (URI) INVESTIGATIONS INTO THE SHOCK-INDUCED ENHANCEMENT OF MIXING AND COMBUSTION IN SUPERSONIC BURNERS

CONTRACT NO. F49620-86-C-0113 10/1/86 to 9/30/90

#### EXECUTIVE SUMMARY

The Department of Defense, under its University Research Initiative Program, administered by the Air Force Office of Scientific Research, established, in October 1986, a three-year research program at The California Institute of Technology, to address the problems of mixing and combustion in a supersonic air stream related to the technological issues which face the propulsion system for hypersonic and trans-atmospheric aircraft. Our research efforts focused on the very rapid controlled mixing of hydrogen and air that may be induced in a supersonic air stream by the interaction of weak shock waves with the unmixed gases. The aim was to make creative use of available facilities to obtain information which, for lack of conventional facilities, would be unobtainable for some years.

Shock tube experiments have demonstrated that, using shock enhancement techniques, an acceptable degree of mixing can readily be obtained within less than one millisecond after shock impingement, a time we consider acceptable for scramjet burners. The shocks employed are sufficiently weak that negligible losses would be imposed on the scramjet performance. These results have been very satisfactorily compared with detailed computational analyses. Having established that confidence, we are able predict mixing results for different gases and for different strengths of shock employed in the enhancement process. Additional experiments have been carried out on time pulsed vortices of sufficient size to allow examination of the combustion details within the vortices.

Our results have been very encouraging, not only to us but to the NASP engine community which we keep informed of our progress. The promise shown by our experimental and computational results were a major factor in obtaining additional funds from the NASP Technology Maturation Funds, administered through NASA Langley Research Center. Under this grant we have been able to design and fabricate a primitive "practical" hypervelocity injector and mixer, for wind tunnel experiments at Langley. This model has been run in the Langley Mach 6 tunnel during the summer of 1990 and the results have not only confirmed our shock tube experiments but have demonstrated the possibility of practical implementation of the shock enhancement technique. We have benefited greatly from the support and encouragement we have received from industry, NASA and Air Force Laboratories, and other research institutions.

In spite of the success of this program, one must resist the presumption that the mechanism and its technological application are completely understood. Rather we believe that our results should encourage pursuit of significant and unexpected issues that have arisen in our work, and one of them is an issue of practical technology. A scramjet engine must be able to adapt its internal fluid mechanics to a wide range of internal Mach number, air pressure and temperature, and hydrogen velocity ratio. At each of these states, the combustion heat release pattern along the engine must be carefully controlled. It is clear, therefore, that the technological importance of mixing and combustion enhancement by shock interaction is not only to *minimize* the residence time, but to *control* the heat release pattern to near optimum over a wide range of engine operating conditions. This requirement extends the need for understanding the basic shock enhancement mechanism through a search for principles by which data may be "scaled" with respect to the controlling physical parameters.



<b>Accession For</b>	
NTIS GRA&I	<input checked="" type="checkbox"/>
DTIC TAB	<input type="checkbox"/>
Unannounced	<input type="checkbox"/>
Justification _____	
By _____	
Distribution/ _____	
<b>Availability Codes</b>	
Dist	Avail and/or Special
A-1	

## 1. INTRODUCTION

During the past five years of active work on the National Aerospace Plane the key issues for hypersonic flight above a Mach number of six have been quite clearly recognized and delineated, e.g. Nortnam & Anderson (1986) and Van Wie et al (1987). A recent evaluation, Kerrebrock et al (1989), of the problems and current state of technology was completed early in 1988. As a result of the constraints imposed by the entire NASP system, the high speed scramjet propulsion system poses very difficult problems related to the injection and combustion of hydrogen fuel, Anderson et al (1987).

These constraints may be seen qualitatively as follows: Above a Mach number of 8 active cooling, using hydrogen as the coolant, is required over parts of the airframe and over a major portion of the engine. There is good reason to believe that in the higher Mach number range, say above  $M = 14$ , the cooling requirement will produce more hydrogen vapor than required for combustion in the engine. Because this vapor can not be recycled, it must be disposed of in a manner which effectively reduces the fuel specific impulse of the engine and increases the hydrogen required for a given mission.

The effect of this augmented hydrogen requirement is striking. Because liquid hydrogen is a very low density liquid, the volume of the airplane itself is to a considerable extent determined by the fuel volume. As a consequence, the cooling requirement, over and above that necessary for stoichiometric combustion, is possibly the highest leverage factor affecting the size and take-off weight of the airplane for a given payload.

Now because the preponderant fraction of the cooling load occurs within the engine itself, it is extremely important to minimize the length of the engine. Within the engine, length translates into time: time required for injection and mixing and the time required for chemical reaction. For a combustor Mach number of six (which might correspond to a flight Mach number of fifteen) the gas travels between two and three meters in one millisecond. Most of this time, or distance, is taken up by the hydrogen-air mixing process and the reduction of required mixing time directly implies a major reduction in system take-off weight.

Because many of these factors were recognized by some of the Caltech Faculty, we have, with the financial support of the subject contract over the past three and one half years, undertaken a major investigation into the basic mechanisms of enhancing the mixing rate and burning of hydrogen with air. The gasdynamic mechanism and the status of the experimental and computational investigations has been discussed in some detail by Marble(1985), Marble et al (1987), Marble et al (1990). At this point it is sufficient to say that promise of our basic concept has been recognized to the point that, through the NASP project office and NASA Langley Research Center, Technology Maturation Funds were provided for us to design and build a primitive "practical injector," which embodies this concept, for experimental evaluation using the Mach 6 High Reynolds Number tunnel at the Langley Research Center. We are carrying out this program at the present time and it will be discussed later in this report.

The successful results of our experimental and computational program are most gratifying, but one must resist the temptation to conclude that the mechanism and its technological application are understood. Rather we believe, in view of the difficulties of the problem, that our results should be considered sufficiently encouraging to pursue the significant and unexpected issues that have arisen in our work and will be described in this report. As in any basic investigation, we have uncovered more unexplored issues than we have clarified. A few, but certainly not all, of these must necessarily be settled before the claim may be made to understand the later phases of our enhanced mixing process. In addition, because any practical injector must function over a wide range of combustion chamber Mach number, Reynolds number, and hydrogen injection rate, the manner in which the shock enhancement phenomenon scales must be examined in detail.

## 2. REVIEW OF THE RESEARCH PROGRAM AND ITS CURRENT STATUS

Beginning in 1986, with the technical and financial support of the Department of Defense, under Contract F49620-86 C-0113, administered by AFOSR, work began at Caltech to assemble the advanced diagnostic instrumentation and to make extensive modifications to experimental facilities required for a detailed investigation into the use of shock waves to enhance the mixing rate of hydrogen and air. The major part of the work was to be carried out in the GALCIT 17" shock tube and in the Unsteady Combustion Facility of the Jet Propulsion Center.

The concept of this program was to utilize existing facilities in a creative manner to obtain information which otherwise would await the development of new facilities. The concept is illustrated in Fig.1 where we picture a cylindrical stream of hydrogen, flowing parallel with the supersonic air stream, intersected with a relatively weak oblique shock wave.

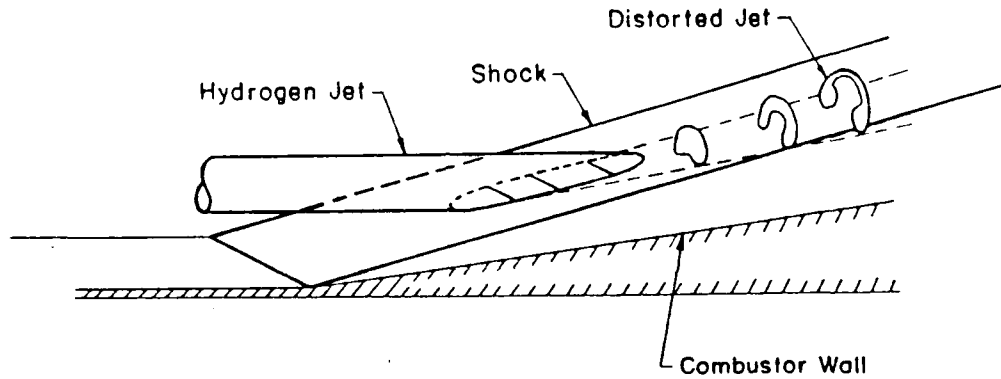

### 1. Distortion of Hydrogen Jet in Hypervelocity Air Stream.

As a result of the differences between the properties of gaseous hydrogen and air, strong streamwise vorticity is generated at the interface between the hydrogen and air. This vorticity rapidly distorts the cylindrical cross section as shown by the sketch and computation in Fig. 2. A shadowgraph of the actual process is shown for comparison. This distortion not only extends

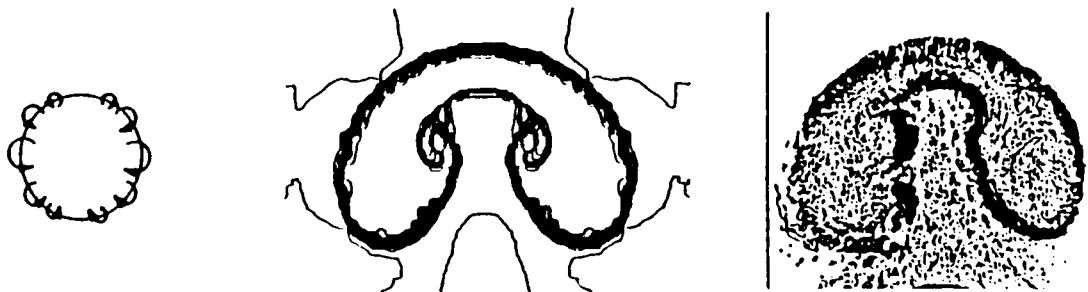

### 2. Vorticity Distribution, Computation and Shadowgraph of Distorted Hydrogen Jet

enormously the interface between hydrogen and air but the shear layer created by the vorticity rapidly leads to instability of the interface. The extension and instability of the interface promotes very rapid mixing to the molecular level which, in turn, allows chemical reaction.

The possibility of examining a streamwise developing process in terms of one that develops in time allows a difficult continuous hypersonic flow experiment to be replaced with a time resolved shock tube experiment having the advantage of superior diagnostic access. The use of the 17" shock tube for this investigation was stimulated by experiments performed by Sturtevant in the early 1980's, described in a recent paper, Haas & Sturtevant (1986), concerning the scattering of shock waves by gas inhomogeneities in the atmosphere.

Our program, undertaken in 1986, focused on the distortion and rapid mixing of the inhomogeneity itself, interpreting time elapsed in the shock tube experiment as the distance downstream of injection, as detailed above. The principle quantitative technique employed has been the laser induced fluorescence of biacetyl. Using this technique, Marble et al (1987), it was possible to record light gas density distributions (implying the degree of mixing between fuel and air) within a one millimeter thick cross section of the cylinder with a time resolution of a few microseconds.

We have carried out a program of shock tube experiments in which a cylindrical jet of helium, convecting vertically in the working section of the shock tube, was used to model the hydrogen cylinder. A shock wave was produced in the tube which propagated in a direction normal to the axis of the cylinder, as shown in Figure 3. During the ensuing interaction process the

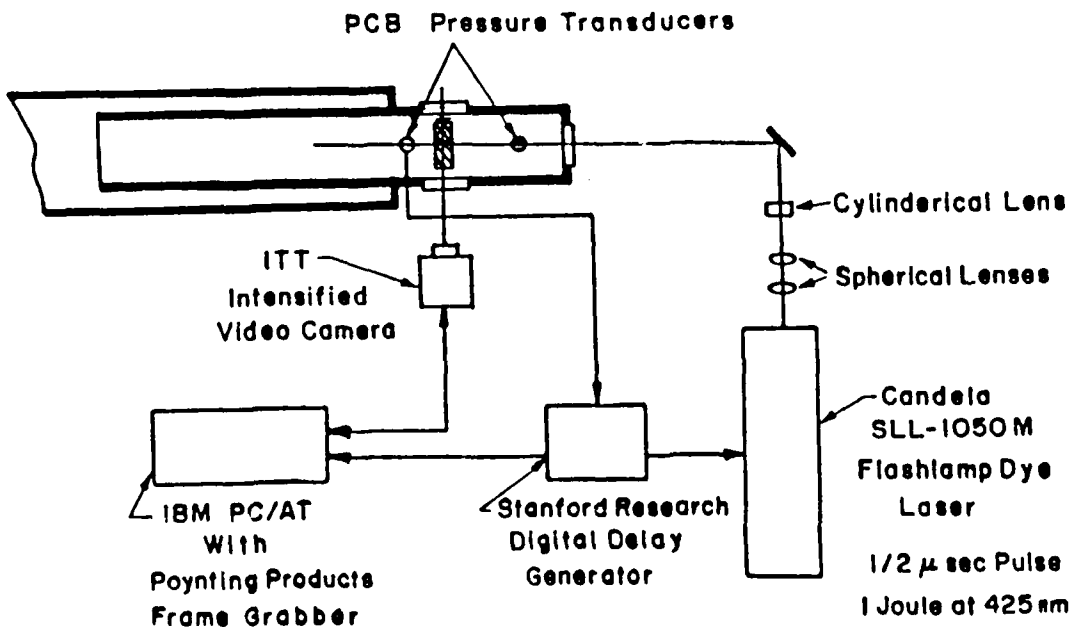

3. Sketch of Shock Tube Experiment.

concentration of helium was determined by measuring the laser induced fluorescence of bvacetal dye which was mixed with the helium. The intensity of the fluorescence was measured with an enhanced video camera and calibration of the camera-shock tube system allows quantitative determination of the local dye concentration. In these experiments, the laser sheet cuts a cross section of about 0.5 mm thickness, normal to the cylinder axis, with a time resolution of about 2 microseconds and the interaction process could be followed for times of up to two milliseconds after shock impingement. Details of the experiment and experimental results, given in Jacobs (1988) and Jacobs (1990), are reviewed here briefly.

A set of photographs illustrating the interaction process for a one millisecond period is shown in Fig.4 where the region within which the concentration of helium is above 20% of the original value is shown in black, for the purposes of this report. Color enhanced treatment of this data, Jacobs (1988), gives a much more detailed picture of the distribution of the dye than can be given here in black and white.

The experiments show that the interaction process initially breaks the cylinder of helium into a vortex pair connected by a thin umbilical cord that soon mixes. As the flow develops, each vortex breaks up into two distinct regions which can be clearly defined in the color photographs and in shadowgraphs of the flow. We have designated one region the front lobe, which develops into what appears to be a strongly stratified vortex pair, and the back lobe which mixes rapidly with the surrounding air and disappears. By the 0.988 ms time frame, about 60% of the initial helium has been mixed with air to form a mixture with less than 10% helium concentration. We shall return to these experimental results later in this report.

An extensive computational program was undertaken as a parallel effort to allow analysis of flow field features, such as the pressure and the vorticity, that were difficult or impossible to measure in the experiment. The "verification" of our code was carried out utilizing the spark shadowgraphs, mentioned earlier, together with the computed gas density distributions. Even superficial comparisons, such as that shown in Fig. 2, show a striking accuracy which is confirmed by detailed comparison. The advantage of this computational capability lies in the resulting ability to perform numerical experiments, allowing a careful choice of the more expensive and time consuming physical experiments. Extensive use will be made of this code in Section 4 of this report in which we examine the outstanding problems that remain in this investigation.



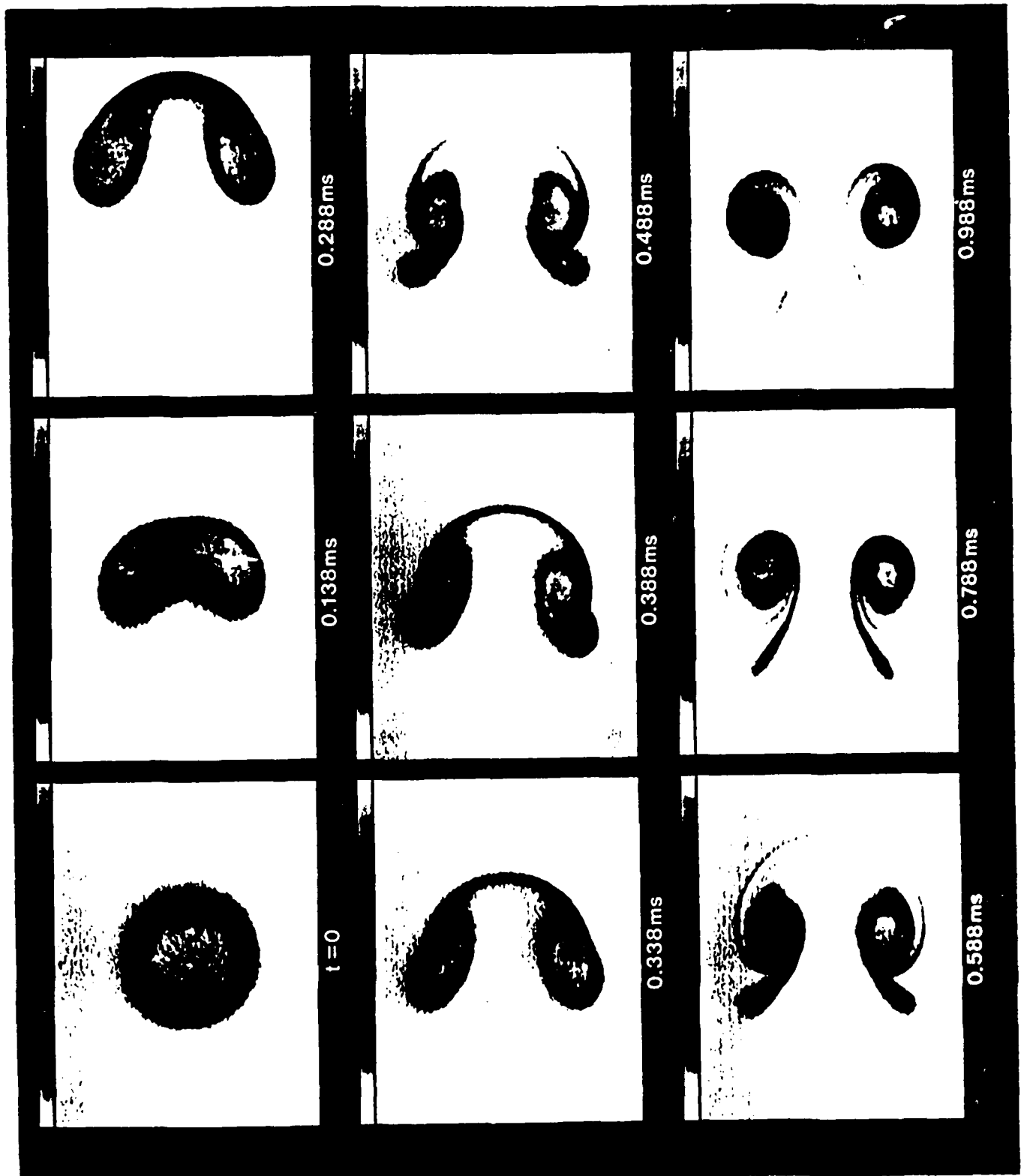

4. Laser Induced Fluorescence Images of Shock Enhanced Mixing.  
Helium in Air

The experimental portion of the program carried out in the Unsteady Combustion Facility aimed to examine a different aspect of the combustion phenomenon. The actual detail of combustion within the vortex structure is not specifically addressed in the shock tube study. The Unsteady Combustion Facility, Smith & Zukoski (1985), Marble et al (1987), shown schematically in Fig. 5, utilizes a pulsed flow over a downstream facing step to generate large vortices in a combustible mixture. The spatial resolution of one millimeter square within a five to seven centimeter diameter vortex allows determination of the distribution of heat release through measurement of chemiluminescence and ion concentration. Figure 6 shows a typical time resolved map of chemiluminescence along with the more familiar spark shadowgraph at a corresponding time of the vortex burning period. We have just reached the point where quantitative evaluation of these data are possible and this activity is continuing.

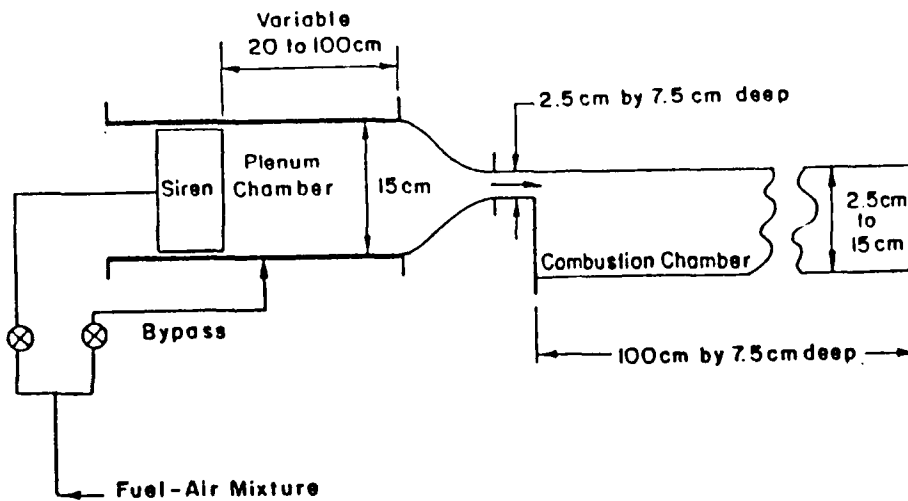

5. Schematic View of Unsteady Combustion Facility

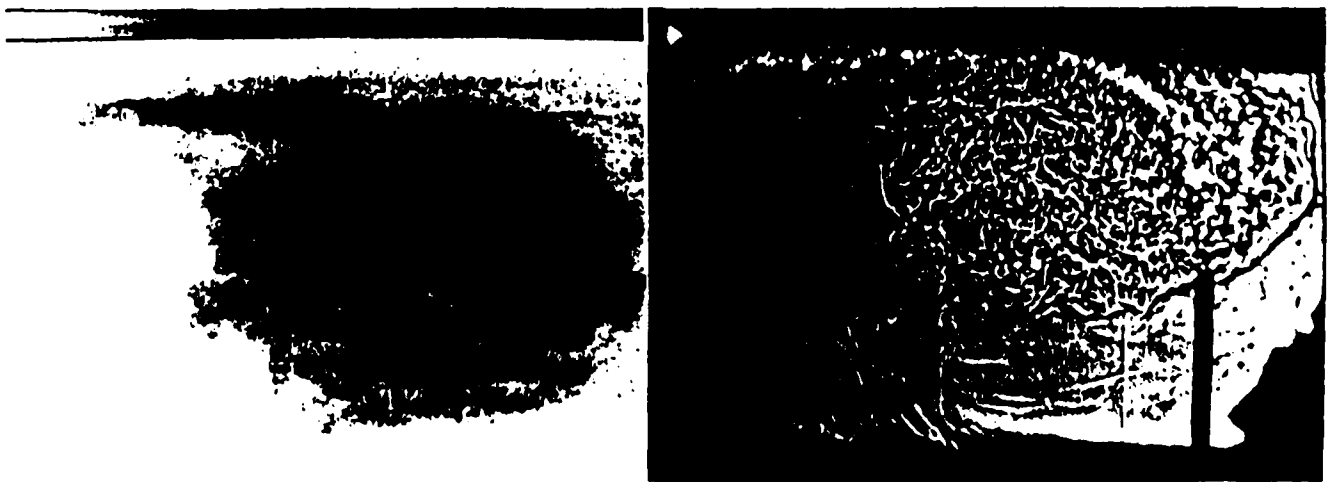

6. Heat Release Map and Corresponding Shadowgraph during Vortex Combustion.

A detailed numerical analysis of the flow in both the Shock Tube and the Unsteady Combustion Facility has been carried out, Hendricks & Marble (1990) using the Flux Corrected Transport method developed by Boris & Book (1976), and a modified form of the computational code developed by Picone & Boris (1988). Because the time scales here are a few milliseconds, viscous effects do not play an important role in the evolution of the flow field and hence the Euler code was considered satisfactory. The results of these computations have been very important in guiding the experimental work and in explaining features of the flow field that could not be measured.

Computations have been carried out for a wide range of initial values for the parameters of the system including: shock Mach number, specific heat ratios, density ratio of light to heavy gas, initial thickness of diffusion layer at the boundary of the light gas cylinder, and the initial geometry of the interface. Only those conclusions drawn from calculations of the basic flow will be discussed here.

As the shock passes the light gas cylinder vorticity is deposited at the interface, increasing from zero at the initial point of contact to a maximum where the shock passes the major diameter, where the pressure and density gradients are perpendicular, then decreasing to zero at the rearmost point. Although some vorticity production does occur after passage of the shock, calculations show that the circulation about the upper (or lower) half of the flow is very nearly constant after the shock has passed.

The subsequent development of the flow distortions is thus almost totally due to the self-induced velocities produced by the vorticity that has been deposited at the circumference of the cylinder. One aspect of this motion is that the distorted structure moves through the ambient gas with a velocity which varies from about 75% of the gas speed behind the shock early in the development to roughly 15% later on. This relative velocity is of little importance for the shock tube experiments but can be significant in fuel injector design.

Results of a single computation for a Mach 1.10 shock strength at three different times are shown in Fig. 7 for a flow similar to that shown in the photographs of Fig. 4. Figures 7a, 7b, 7c show the computed density field and the lines of constant density correspond very nearly to lines of constant composition. Figure 7d gives the pressure contours corresponding to Fig. 7c. The mechanism by which the vorticity is redistributed during the development to the later configuration is of particular interest. The two relevant are the convective transport and the barotropic generation and annihilation. The first is possible because the vorticity is initially deposited in the thin layer where the composition gradient is large. Because this may involve only a small fraction of the helium, the helium carrying the vorticity may migrate toward the front and leave the less vortical portion in the rear part of the structure. The barotropic generation is important because significant pressure gradients remain in the field after passage of the original shock. The relative stability of the stratified vortex which appears in the late stage of development may be inferred from the colinearity of the density and pressure contours in Figures 7c and 7d.

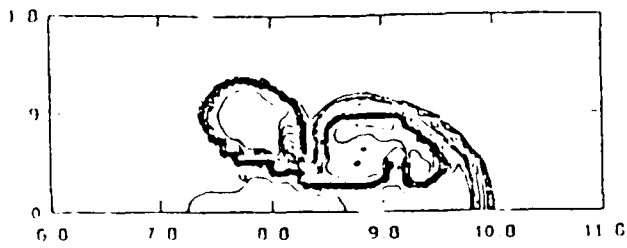

Density, 1.09 ms

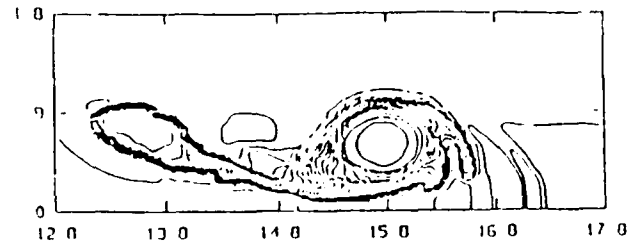

Density, 2.19 ms

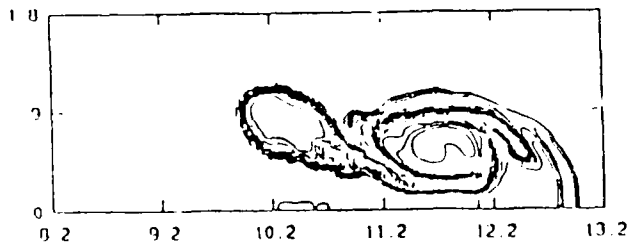

Density, 1.46 ms

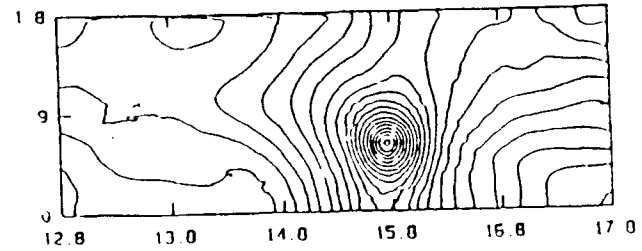

Pressure, 2.19 ms

#### 7. Density and Pressure Fields Computed for Shock Mach Number of 1.10

The computations confirm that the light gas remaining in the front lobes forms a strongly stratified vortex pair which continues to persist in an unmixed condition for times larger than that available in the experimental apparatus. Because these vortices are stratified, they are particularly stable and we expect that continued mixing of this material with air will be slow. Hence, we must rely on mixing due to either the longitudinal shear or another shock interaction to mix this material with the ambient air. The influence of mixing induced by shear and the possibility that a second shock can destabilize the vortex pair are being studied in experimental and computational programs.

### 3. TRANSLATION OF SHOCK ENHANCEMENT CONCEPT TO A HYPERSONIC INJECTOR

During the initial phases of research on the shock enhancement of mixing, the question was frequently posed as to whether such a concept could indeed be accommodated in an engine or whether it was an entity quite apart from engine technology. The opportunity to address this issue was secured through the Technology Maturation Fund of the NASP program. Under a two year NASA grant administered through NASA Langley Research Center, we have the responsibility to design and build a hypersonic injector module, incorporating shock enhancement, and to conduct experiments with it in the Langley Mach 6 one-foot wind tunnel. The model, design of which was completed in early September 1988, is shown schematically in Fig. 8.

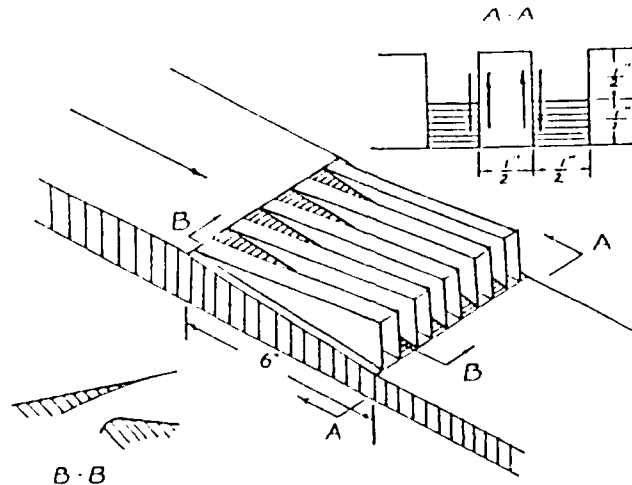

8. Configuration for Hypersonic Hydrogen Injector

The injector consists of alternating compression ramps and expansion troughs located along one wall of the combustor. At the end of each ramp, hydrogen is injected through supersonic nozzles (Fig. 8, Section B-B) parallel with the new level of the combustion chamber. As the air flowing in an expansion trough leaves the end of the ramp, it forms an oblique shock as it is returned to the direction of the combustor wall, of about the same strength as the shock at the leading edge of the ramp.

The adjacent shocks and expansion fans generated at the leading edge of the ramp interact to weaken substantially the leading edge shock and to produce a downward vertical velocity within the trough. Looking upstream into the injector discharge (Fig.8, Section A-A) one sees a vortex sheet generated at the boundary between the hydrogen and air, a feature which is the first step in producing the streamwise vorticity essential to the mixing process.

We arrived at this particular design as the result of a detailed computational study of the flow fields generated by similar geometries and a sample of these results clarifies the mechanism by which shock enhancement is produced. Figure 9 gives the computed density contours within a vertical cross section of the flow at a station one inch upstream of the discharge. The expansion around the upper corners, where the ramp and trough join, is followed by a pair of oblique shocks within the trough which align the flow with the vertical walls of the trough.

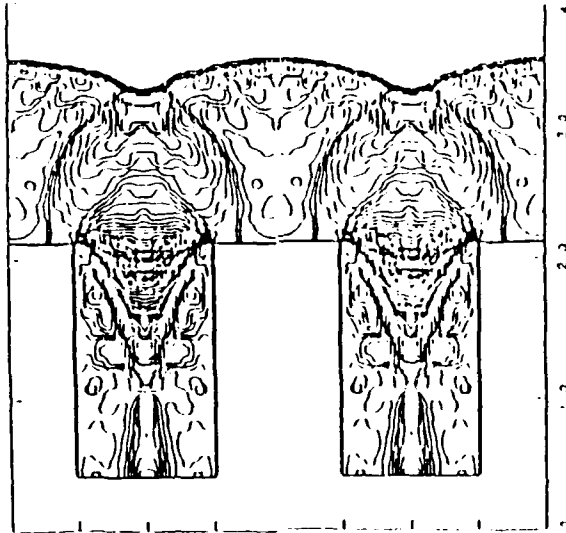

9. Density Contours 1" Ahead of Nozzle Discharge.

The density and vorticity contours for a cross section one inch downstream from the end of the injector are shown in Fig. 10. The density contours of Fig. 10(a) may be compared with the corresponding plot in Fig. 9 one inch upstream of the discharge. Further, because the solid walls of the injector are no longer present, the expansion fans generated by the sharp corners are attenuating rapidly. Strong density gradients now bound the hydrogen stream, half of which appears on each side of the ramp region.

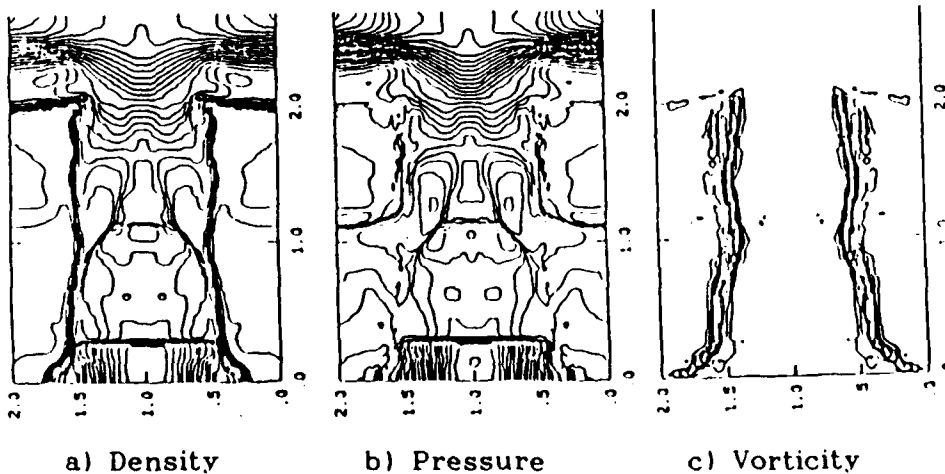

10. Field Contours 1" Downstream from Injector Discharge.

The distinctly new feature which appears here is the shock moving vertically upwards through the air within the trough. This shock is a consequence of turning the trough air back in the streamwise direction by the combustion chamber wall. The essential point is that this shock establishes a high pressure region within the trough air which causes the air to flow in under the hydrogen and to lift the hydrogen jet off the wall, out into the air stream.

The mixing process develops as a result of streamwise vorticity which is

generated partly by the vertical velocity difference between hydrogen and air at the discharge of the injector, but largely by interaction of the shock wave with the density difference between the hydrogen and the air. The pressure field in question here is shown in Fig. 10(b). Figure 10(c) gives the contours of streamwise vorticity which is concentrated along the air-hydrogen interface. The thickness of the vorticity distribution which appears in this figure results from the small-scale inviscid rolling up of this interface.

Figure 11 shows plots similar to those of Fig. 10 but at a distance of 6 inches downstream from the injector discharge. First, referring to Fig. 11(a), note that the hydrogen jets have been indeed lifted off the wall and strongly resemble the vortex pair configuration observed in the shock tube studies, Fig. 4. Second, referring to Fig. 11(c), note the very large extent to which the air-hydrogen interface has been rolled up and transported by the small-scale, inviscid vortical motions.

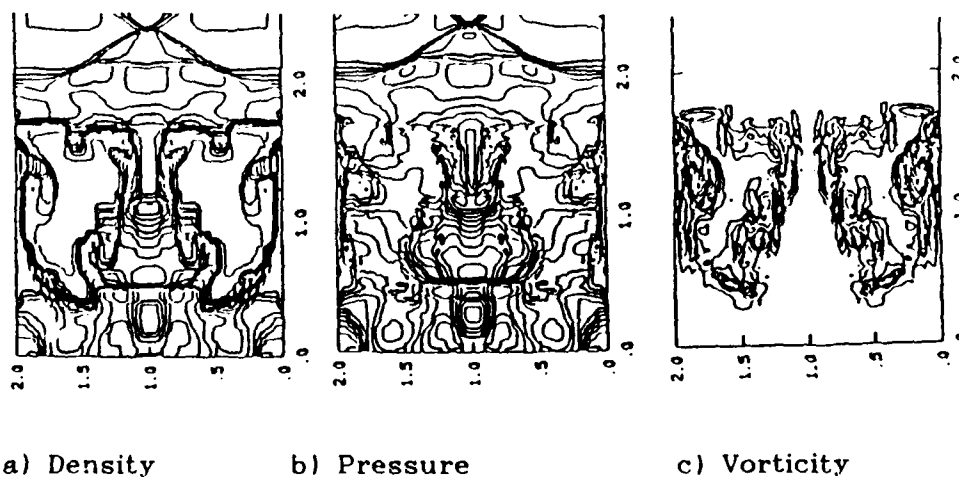

11. Field Contours 6" Downstream from Injector Discharge

On the basis of these studies, a model of the injector was designed for installation in the Mach 6 high Reynolds number tunnel at the NASA-Langley Research Center and fabrication was completed early in February 1989. An extensive series of experiments was carried out by Caltech personnel with the technical support of Langley Research Center during the summer of 1990. Although the results have not yet been analyzed thoroughly, it is clear that the injector performed very much as predicted by the shock tube studies and numerical analysis. More experimental time at Langley has been scheduled and completion is expected by Spring of 1991.

This work constitutes both a "proof of concept" test and a demonstration of design problems not appreciated initially. There are basic issues involved in this configuration in addition to those treated in the shock tube study among which are the shear due to the difference between airstream and hydrogen injection velocities and the effects of boundary layer structure at the discharge nozzle. Some of these issues are described in the following section.

#### 4. THE BASIC SCIENTIFIC AND TECHNOLOGICAL ISSUES

The extensive research program we have pursued over the past three years has confirmed the potentiality of shock enhancement as a means of controlling and accelerating the rate of mixing between gases of very different molecular weights. Equally important, it has clarified and focused our perception of the basic issues, both scientific and technological, that control and limit the mixing process, determine its scaling laws; issues that must be faced in the process of transferring the concept to a practical hypersonic combustor.

One of the most challenging of these is what we may refer to as stabilized stratification. This situation is familiar from a variety of natural convection situations in which a gravitationally stable stratification (one in which the density decreases as the altitude increases) is sufficiently strong to inhibit instability of interfaces normal to the gradient field. In our situation, the vorticity at the interface between hydrogen and air creates an unstable shear layer which will, under usual circumstances, develop into a strong mixing layer. On the other hand, the configuration of the vortex with the lower molecular weight gas near the center tends to be stabilized against shear instability by a strong centripetal acceleration associated with the circulation of the vortex.

The laser induced fluorescence photographs shown in Fig. 4 provide vital information in this regard. Initially the cylindrical cross section develops strong mixing at the interface. As the motion develops, a change takes place that can be most easily understood by examining the computations. Figure 12 shows density and vorticity contours at a time corresponding to approximately .29 ms in Fig. 4. At about .79 ms the same physical quantities, Fig. 13, show that the vorticity has, to a remarkable extent, migrated to the right-hand portion of the structure, leaving the left-hand portion free from vorticity. For later times, these two regions behave in completely

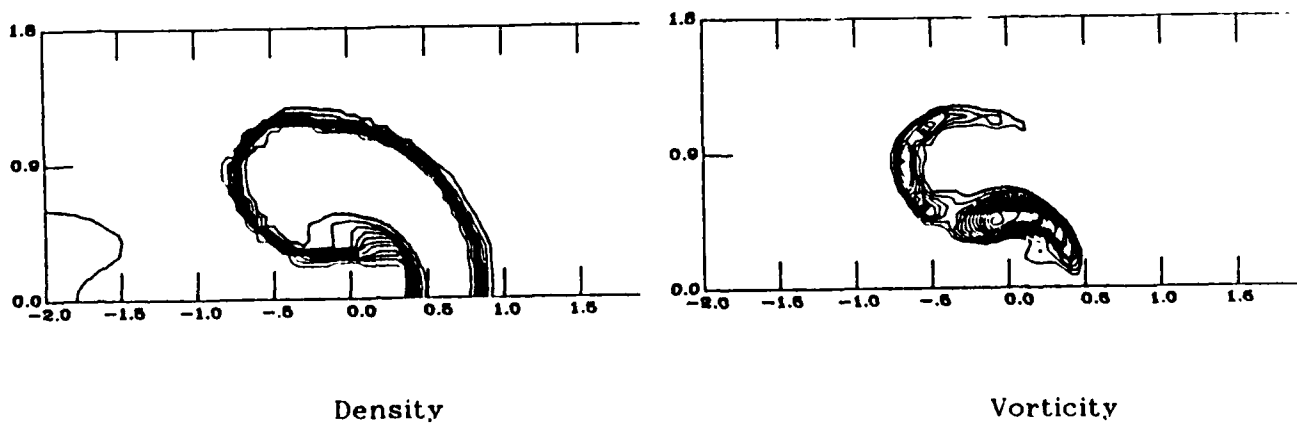

12. Density and Vorticity Contours .29 ms after Shock Impingement  
different manners; the vorticity-free region mixes rapidly whereas the material



containing the vorticity forms a symmetric vortex. The consequence is most clearly exhibited by the rates with which the helium mixes in each of these regions. Figure 14 shows that the region containing the vorticity mixes the more slowly of the two, giving weight to the contention that mixing of the region on the right is being retarded by the mechanism of stable stratification. The computations from a later stage of the process, Fig. 13, confirm the symmetric vortex-like configuration of the right hand portion of the structure.

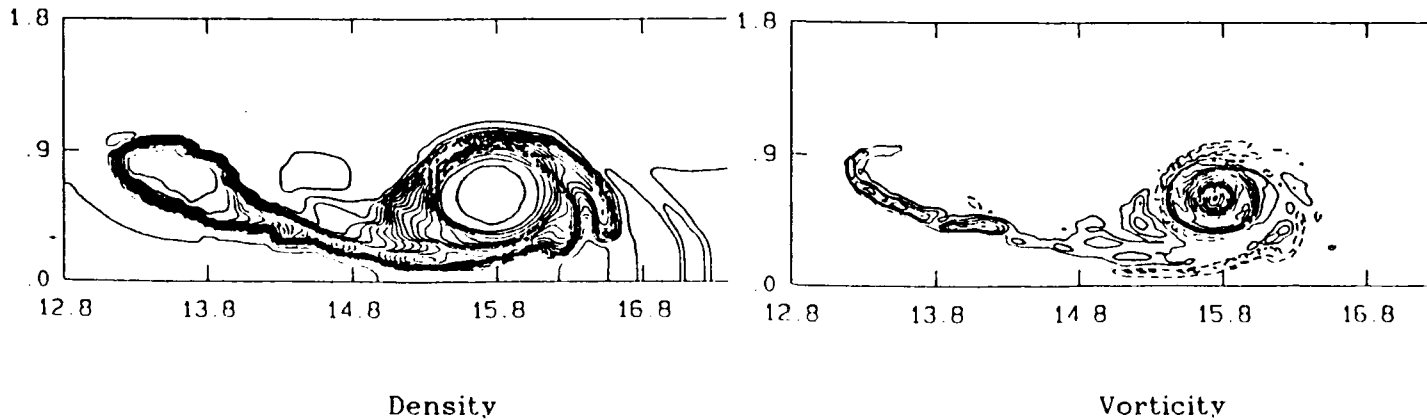

13. Density and Vorticity Contours .79 ms after Shock Impingement

One of the major thrusts of further research in the area of shock enhanced mixing must, therefore, be an investigation into the utilization of shock interaction to destabilize this structure through redistribution of the vorticity. It is essential to examine the strength of shock required and the stage of development most suitable for this interaction.

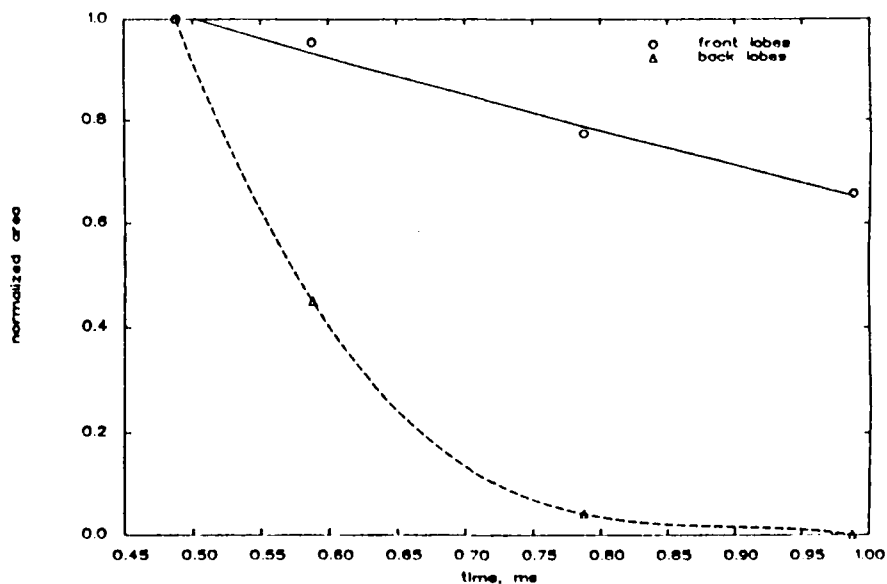

14. Mixing Histories for Non-Vortical and Vortical Regions  
The experience gained in this program, in the conception, design and

computational study of the hypersonic injector utilizing shock enhancement, has provided the relevant framework within which to study basic issues of the problem that are not evident in the shock tube study. The first and most obvious of these, which was justifiably suppressed when the mechanism was being confirmed in the shock tube study, was the shear layer that develops when the hydrogen jet moves at a different velocity than the air. In an engine, the difference between the hydrogen injection velocity and the air velocity in the combustor will vary over the range of free stream Mach numbers between 6 and 18 and, at times, the air velocity may exceed that of the hydrogen jet. The interaction of the shear vorticity component, normal to the direction of flow, with streamwise vorticity, which we have generated by the shock interaction, is a fundamental issue that requires investigation.

The boundary layer, that develops along the inlet ramp and surface of the combustor in which the injector is installed, likewise introduces a vorticity component normal to the flow direction, similar to that associated with the shear created by the jet. The presence of the solid surface, however, alters the situation considerably. One factor, of course, is the possible attenuation to our mixing enhancement presented by the wall. Another is the possibility that the degree and scale of the boundary layer turbulence, which may have developed over a considerable distance ahead of the injector, itself may play a major role in the mixing and combustion processes.

A final point that has been mentioned earlier in this report is that a scramjet engine, because of the immense difficulty of incorporating a variable geometry structure to withstand its very hostile atmosphere, must be able to adapt its internal flow mechanics to a considerable variety of internal Mach numbers, air pressure and temperature and hydrogen mixture ratio. In particular, a fixed internal configuration has poor tolerance for uncertainties in the heat release pattern along the flow path. There is, for minimizing pressure losses and heat transfer rate, an optimum heat release pattern which is different for different operating points and may be achieved only by carefully controlled distributed injectors. It appears that shock enhancement, and some variability of the injection nozzles, can provide a powerful means of controlling the heat release pattern with moving parts residing out of the high temperature regions of the combustor.

From this viewpoint it is clear that the technological aim of mixing and combustion enhancement by shock interaction is not to only *minimize* the required residence time, but to *control* the heat release pattern to near optimum over a rather wide range of engine operating variables. The consequence of this requirement extends the need for understanding the basic shock enhancement mechanism through a search for principles by which data may be "scaled" with respect to the controlling physical parameters.

## 5. REFERENCES

- Anderson, G.Y., Bencze, D.P., Sanders, B.W.(1987), "Ground Tests Confirm the Promise of Hypersonic Propulsion." Aerospace America V. 25 pp. 38-42.
- Boris, J.P. and Book, D.L.(1976) "Flux-Corrected Transport III: Minimal Error FCT Algorithms." Journal of Computational Physics, 20, No. 9, p 1448.
- Haas, J-F., Sturtevant, B.(1988), "Interaction of Shock Waves With Cylindrical and Spherical Gas Inhomogeneities." Jour. Fluid Mech., V. 181, p 41.
- Hendricks, G.J. and Marble, F.E. (1990) "Shock Enhancement of Supersonic Combustion Processes." Jet Propulsion Center Report, Caltech, April 1990.
- Jacobs, J.W. (1988), "PLIF Flow Visualization of a Shock Accelerated Transverse Helium Jet." Physics of Fluids in publication.
- Jacobs, J.W. (1990) "Shock Accelerated Cylindrical Gas Inhomogeneities Part 1. Shock Induced Mixing of a Light Gas Cylinder." Submitted to Jour. Fluid Mech.
- Kerrebrock, J.L.(1988), "Hypersonic Technology for Military Applications." National Research Council, National Academy Press Air Force Studies Board, Committee on Engineering and Technical Systems.
- Kumar, A., Bushnell, D.M., Hussaini, M.Y. (1987), "A Mixing Augmentation Technique for Hypervelocity Scramjets." AIAA Paper No. 87-1882 23rd AIAA Joint Propulsion Conference, San Diego.
- Marble, F.E. (1985), "Growth of a Diffusion Flame in the Field of a Vortex" Recent Advances in Aerospace Sciences Ed. C. Casci, pp 395-413.
- Marble, F.E., Hendricks, G.J., Zukoski, E.E. (1987), "Progress Toward Shock Enhancement of Supersonic Combustion Processes." AIAA Paper No. AIAA-87-1880 23rd AIAA Joint Propulsion Conference, San Diego.
- Marble, F.E., Zukoski, E.E., Jacobs, J.W., Hendricks, G.J., and Waitz, I.A. (1990) "Shock Enhancement and Control of Hypersonic Mixing and Combustion." AIAA Paper No. AIAA 90-1981 26th AIAA Joint Propulsion Conference, Orlando, Florida.
- Northam, G. B. and Anderson, G. Y. (1986), "Review of NASA/Langley Basic Research on Supersonic Combustion." AIAA Preprint 86-0159.
- Picone, J. M., and Boris, J. P. (1988), "Vorticity Generation by Shock Propagation Through Bubbles in a Gas." Journal of Fluid Mechanics, 189, pp 23-51.
- Smith, D.A. and Zukoski, E.E.(1985), "Combustion Instability Sustained by Vortex Combustion." 21st AIAA Joint Propulsion Conference.

Van Wie, D.M., White, M.E., Waltrup, P.J.(1987), "Application of Computational Design Techniques to the Development of Scramjet Engines." AIAA Paper No. 87-1420 19th AIAA Fluid Dynamics, Plasma Dynamics, and Lasers Conference, Honolulu.



## Lectures, Seminars, Meetings

The group associated with this contract has participated in numerous discussions, meetings and presentations during the four years since the work was initiated. The timely nature of the work has also resulted in a great deal more industrial interest and discussion than we have experienced with previous grants. The following lists the more formal of these interactions.

### 1. Formal Presentations

- a) AIAA Joint Propulsion Conferences, 1987, 1990
- b) American Physical Society, 1988, 1990

### 2. Formal Lectures

- a) University of Rouen, 1987
- b) Moscow Aviation Institute, 1989
- c) W. R. Sears Distinguished Lecture, April, 1990
- d) Parker Hannifin Distinguished Lecture,  
Ohio Aerospace Institute, October, 1990

### 3. Seminars

- a) California Institute of Technology
- b) University of California, Irvine
- c) NASA Langley Research Center
- d) Massachusetts Institute of Technology