

AD-A231 649

7-1-13-13

THIS COPY

12

R D & E CENTER

Technical Report

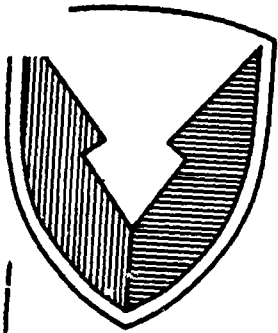

No. 13507

HIGH-MOBILITY MULTIPURPOSE WHEELED
VEHICLE/HIGH-MOBILITY TRAILER
(HMMWV/HMT)

BRAKE ANALYSIS

OCTOBER 1990

DTIC
ELECTE
FEB 15 1991
S B D

By Marc Alexander
U.S. Army Tank-Automotive Command
ATTN: AMSTA-ZDS
Warren, MI 48397-5000

APPROVED FOR PUBLIC RELEASE:
DISTRIBUTION IS UNLIMITED

91 1 9 002

U.S. ARMY TANK-AUTOMOTIVE COMMAND
RESEARCH, DEVELOPMENT & ENGINEERING CENTER
Warren, Michigan 48397-5000

91 1 9 002

NOTICES

This report is not to be construed as an official Department of the Army position.

Mention of any trade names or manufacturers in this report shall not be construed as an official endorsement or approval of such products or companies by the U.S. Government.

Destroy this report when it is no longer needed. Do not return it to the originator.

REPORT DOCUMENTATION PAGE	1. REPORT NO.	2.	3. Recipient's Accession No.
4. Title and Subtitle High-Mobility Multipurpose Wheeled Vehicle/High-Mobility Trailer (HMMWV/HMT) Brake Analysis		5. Report Date October 1990	
7. Author(s) Marc Alexander		8. Performing Organization Rept. No.	
9. Performing Organization Name and Address U.S. Army Tank-Automotive Command Research, Development & Engineering Center Warren, MI 48397-5000		10. Project/Task/Work Unit No.	
		11. Contract(C) or Grant(G) No. (C) (G)	
12. Sponsoring Organization Name and Address U.S. Army Tank-Automotive Command Program Manager Light Tactical Vehicles Warren, MI 48397-5000		13. Type of Report & Period Covered Final	
		14.	
15. Supplementary Notes			
16. Abstract (Limit: 200 words) <p>The Army has a need for a companion High-Mobility Trailer (HMT) for its fleet of High-Mobility Multipurpose Wheeled Vehicles (HMMWVs). The HMT is required to have a Gross Vehicle Weight (GVW) of 3400 pounds and be equipped with either surge or service brakes. Federal Motor Carrier Safety Regulations (FMCSR) 393.42 and 393.48 require that all trailers with a GVW of 3000 pounds and over be equipped with continuously operable brakes. A surge brake is not operable when the prime mover travels in reverse and is usually disconnected when traveling cross-country. Service brakes have the undesirable requirement of modifying the HMMWV. This raises the question: "Are the HMMWV's brakes adequate to safely brake the system in all of its operational scenarios?" If the brakes are found to be adequate, justification of a waiver on the requirement for continuously operable brakes, allowing for the use of a surge brake, is applicable. In order to approach this problem without the necessary costly and time-consuming testing, a brake simulation model of the system was created. The model was validated with a short and inexpensive operational test, which determined a mean percent difference, between test and model predicted braking distances, of 9%. This report contains a copy of the model which requires the use of Lotus 1-2-3, version 2.</p> <p>Using the model, the braking capability of the HMMWV coupled to the HMT was determined. By comparing this capability to its requirement, it was determined that the HMMWV's brakes are adequate and justify a waiver of the FMCSR.</p>			
17. Document Analysis a. Descriptors Braking Safety Study Brake Simulation Model			
b. Identifiers/Open-Ended Terms High-Mobility Multipurpose Wheeled Vehicle High-Mobility Trailer			
c. COSATI Field/Group Engineering			
18. Availability Statement UNLIMITED		19. Security Class (This Report) UNCLASSIFIED	21. No. of Pages 100
		20. Security Class (This Page) UNCLASSIFIED	22. Price

TABLE OF CONTENTS

Section	Page
1.0 INTRODUCTION	8
2.0 OBJECTIVE	8
3.0 CONCLUSION	8
4.0 RECOMMENDATIONS	11
5.0 DISCUSSION	11
5.1 <u>Background</u>	12
5.2 <u>Analysis</u>	13
5.2.1 Force Analysis	13
5.2.2 Predicting Lock-up	15
5.2.2.1 HMMWV Brake System Information	15
5.2.2.2 Technical Manual Drawings	15
5.2.2.3 Predicting Brake Lock up	15
5.2.3 Braking with Lock up, Surge Brake Inactive	20
5.2.4 Energy Analysis	22
5.2.5 Braking Without Lock-up	23
5.2.6 Braking With an Effective Surge Brake	25
5.2.7 Coefficient of Tire/Surface Friction	27
5.2.7.1 Kinetic Friction	27
5.3 <u>Model</u>	27
5.3.1 User Dependent Variables	27
5.3.2 Results	29
5.3.3 Independent Variables	29
5.3.4 Weight Dependent Variables	30
5.3.5 Weight and Grade Dependent Variables	30
5.3.6 Braking Variables	30
5.3.7 Coefficient of Tire/Surface Adhesion Dependent Variables	31
5.3.8 Macros	32
LIST OF REFERENCES	34
DISTRIBUTION	DIST-1
APPENDIX A. HIGH MOBILITY TRAILER OPERATIONAL & ORGANIZATIONAL PLAN ..	A-1
APPENDIX B. BRAKING MODEL	B-1
APPENDIX C. OPERATIONAL MODEL VALIDATION TEST AT GENERAL MOTOR'S PROVING GROUNDS, MILFORD, MICHIGAN	C-1
APPENDIX D. MODEL VALIDATION BASED ON TEST DATA FROM PROTOTYPE QUALIFICATION TEST AT YUMA PROVING GROUNDS	D-1
APPENDIX E. MODEL VALIDATION BASED ON TEST DATA FROM PROTOTYPE QUALIFICATION TEST AT ABERDEEN PROVING GROUNDS	E-1
APPENDIX F. HIGH MOBILITY TRAILER REQUIRED OPERATIONAL CAPABILITY	F-1

	<input checked="" type="checkbox"/> <input type="checkbox"/> <input type="checkbox"/>
Supply Codes and/or Special	
A-1	

TABLE OF CONTENTS
(Continued)

Section	Page
APPENDIX G. NOMENCLATURE	G-1
APPENDIX H. HMMV BRAKE BIAS TEST DATA	H-1
APPENDIX I. FEDERAL MOTOR CARRIER SAFETY REGULATIONS 393.42 - 393.52 ..	I-1

LIST OF ILLUSTRATIONS

Figure	Title	Page
5-1	Free Body Diagram - HMMWV and HMT	14
5-2	Axle Rotor Relation	16
5-3	Axle Gear and Wheel Gear Box	16
5-4	Internal Mechanics of Wheel Gear Box.....	17
5-5	Brake Assembly	18
5-6	Free Body Diagram - HMMWV Tire/Caliper.....	19
5-7	Kinematic Diagram - HMMWV and HMT	21
5-8	XM1071 Trailer Used for the Model Validation Test	26

LIST OF TABLES

Table	Title	Page
3-1	Model Predicted Braking Distances	9
5-1	Values of Static Tire/Surface Coefficients of Friction...28	

1.0. INTRODUCTION

This report describes a technical analysis of the braking ability for the High-Mobility Multipurpose Wheeled Vehicle (HMMWV)/High-Mobility Trailer (HMT) System. The HMT Operational and Organizational (O&O) Plan states that the trailer must be equipped with a service or surge brake (See Appendix A, para 4g). Federal Motor Carrier Safety Regulations (FMCSR) 393.42 and 393.48 (See Appendix I) require that all trailers above a Gross Vehicle Weight (GVW) of 3000 lbs be equipped with continuously operable brakes. If the trailer is equipped with a surge brake, the regulation is violated. First, because the brake is inoperable in reverse and second, it is ordinarily disconnected during cross-country operation so as not to degrade the mobility of the system. Equipping the trailer with a service brake would require modification to the HMMWV, an undesirable requisite. This dilemma raises the question:

If equipped with a surge brake and it has been disconnected, would the HMMWV's brakes be adequate to safely brake the system in all required operational scenarios, and would this safety margin be sufficient to secure a waiver on the requirement for continuously operable brakes?

In order to thoroughly study this complex problem without the necessary costly and time-consuming testing, a mathematical model was created using a Lotus 1-2-3 spreadsheet (See Appendix B). The model, with minor modifications, could be used for a braking study of any wheeled vehicle or wheeled vehicle/trailer combination. Validation of the model was achieved with a short and inexpensive instrumented operational test of the system, a HMMWV and trailer, (See Appendix C) and with comparison to previous brake tests (See Appendix D & E).

2.0. OBJECTIVE

The objective of this analysis has two parts: First, to create a tool for determining the braking ability of the HMMWV/HMT system. Second, with this tool, determine whether the need for continuously operable brakes is valid to maintain a safe braking performance.

3.0. CONCLUSION

The model was validated with an operational test performed at General Motors Proving Grounds, Milford, Michigan, on June 6, 1990 (See Appendix C). The mean percent difference between model predicted braking distances and the test results was found to be 9 percent. Using the model, Table 3-1 was generated. The table shows braking distances, with and without a surge brake, with respect to the coefficient of tire/surface friction (μ). These distances were generated with the HMMWV and trailer loaded to their GVWs, an initial velocity of 30 MPH, on a flat surface, and a brake peddle force of 349 pounds-force. The brake peddle force of 349 pounds is an average of the brake peddle forces that occurred in the validation test. This force is considered an emergency or panic value.

Table 3-1
 Model Predicted Braking Distances

<u>Coefficient Tire/Surface Friction μ</u>	<u>Braking Distance Surge Inactive</u>	<u>Braking Distance Surge Active</u>	<u>Surge Percent Effectiveness</u>
0.02 (ice)	2208	2188	1
0.12 (snow)	368	348	6
0.40 (hard pack)	110	93	15
0.56 (wet soil)	79	62	22
0.62 (gravel)	71	55	23
0.73 (dry soil)	62	40	35
0.78 (asphalt)	62	40	35
0.87 (concrete)	62	40	35

As seen, the surge brake contributes significantly to the braking ability of the system. At coefficients of 0.73, 0.78, and 0.87 the braking distance is constant. This is because the brakes unlocked at 0.67. Therefore, instead of the braking distance being dependent on the coefficient, it is dependent on the brake peddle force which is constant. It was interesting to note that the surge brake is more efficient when the HMMWV brakes are not locked up. This was proved by increasing the brake peddle force to 400 lbs, at which point the HMMWV brakes are locked at a coefficient of 0.73. The braking distances at this point were 45 and 60 feet, with and without a surge brake respectively. These values imply an efficiency of 25%, which is considerably less than the 35% attained when the HMMWV brakes were not locked up.

The following is taken from the performance specification for the HMMWV, page J-383, paragraph 3.7.15.

Braking:

"Under all conditions of loading, the service brake shall stop the vehicle from a speed of 20 MPH in 20 feet, or less, from the point at which movement of the brake peddle begins in accordance with MIL-STD-1180, requirement 105. Deceleration and stopping distance shall be demonstrated on dry, hard approximately level road surface that is free from loose material. The brake peddle force to achieve the above performance shall not exceed that which can be applied by a 5th percentile female driver."

This Performance standard does not consider a trailer. Federal Motor Carrier Safety Regulation 393.52 Braking Performance, section d, states that; "Property carrying vehicles, with a trailer over 3000 pounds, have a braking distance of 40 feet, from an initial velocity of 20 MPH.

Borrowing from the HMMWV Performance Specification, requiring a 5th percentile female driver, an applicable brake peddle force was needed. The operational test had a mean brake peddle force, applied by the driver, an average built male, of 349 pounds-force. The 5th percentile female driver can achieve 64.2%^{1*} of a males strength or 224 pounds-force. According to the model, using 224 pounds-force and dry concrete ($\mu=0.77-0.85$), the braking distance with an active surge brake is 27 feet. Without a surge brake the braking distance is 43 feet. Forty three feet exceeds the allowable braking distance by 7.5%. Note that 7.5% is within the models margin of error, 9%. The system, when traveling on a paved road while deployed in the field, would more than likely have an operating surge brake. Soldiers tend to disconnect the surge brake when traveling cross-country. Also, the operational test was performed with the trailer loaded to a GVW of 3465 pounds, 65 pounds over its requirement.

The following was taken directly from the HMT draft Required Operational Capability (ROC), dated 25 January, 1990 (See Appendix F):

* Numbers refer to the references found in the List of References

"At Gross Combined Weight (GCW), (HMT) be capable of negotiating a 40 percent side slope and ascending/descending 40 percent longitudinal grades without slipping or overturning. The parking brake should hold the HMT at GVW on a 30 percent longitudinal grade." (See draft ROC, Appendix F, page F-9, para 1.b.13).

According to the model, a brake peddle force of 285 pounds-force is required to hold the system, loaded to the GVW, on a 40% grade. Note, when the system is held on a grade (static) the surge brake is inactive. This force exceeds the calculated capability of a 5th percentile female. The ROC specification does not require the system to hold on a 40% grade but just be capable of ascending/descending. The model predicts that a peddle force of 145 pounds-force is required to hold the system on a 30% grade, well within the range of the 5th percentile female capability. Furthermore, it was determined that a 5th percentile female can hold the system on a grade of up to 33%.

It should also be taken in to consideration that a surge brake will never lock up the wheels of the trailer except, when on a high negative slope. When the trailer is pressed against the HMMWV, as it slows, the surge brake's piston is pushed into the brake cylinder activating the drum brakes. This causes the trailer to slow pulling the trailer back, away from the HMMWV and releasing its brakes. Therefore the trailer brakes cannot lock up. When the brakes on a trailer lock up there is a high risk of "jack knifing" due to loss of lateral stability.

4.0 RECOMMENDATIONS

Based on the results outlined in the conclusion, the HMMWV/HMT system meets within reason, or exceeds its braking requirements, even without the use of a surge brake. Therefore, it is recommended that a continuously operable brake for the trailer, required according to Federal Motor Carrier Safety Regulations 393.42 and 393.48, is not necessary. Hence, according to this analysis, a waiver on this regulation is justified.

5.0 DISCUSSION

The primary goal of the analysis was to create a mathematical model which describes the braking ability of the HMMWV/HMT System in various operational configurations. This model would then be used to determine whether the HMMWV brakes alone are adequate to safely brake the system and therefore justify a waiver on the requirement for continuously operable trailer brakes. The model was made using a Lotus 123 spreadsheet (See section 5.3. and Appendix B) containing equations describing the braking effect of the HMMWV/HMT system. The model predicts the braking effect of the system while allowing variation of the following parameters:

- 1) Initial Velocity
- 2) Brake Peddle Force

- 3) Weight: Trailer
HMMWV
- 4) Grade
- 5) Surge Brake Active or Inactive
- 6) Traveling Up or Down Hill
- 7) Traveling in Forward or Reverse

The model simultaneously calculates the braking distances for an incremental range of tire/surface friction coefficients (between 0 - 1.0). The model also predicts whether or not the wheels lock up. An operational test of the system, with all variables precisely defined, including the coefficient of friction, was used to validate the model (See Appendix C). The operational test determined a mean percent difference between model predicted and experimental distances of 9%. The model could be configured to predict the braking performance of any wheeled vehicle, if the necessary information were provided.

5.1. Background

The following is directly from the HMT O&O Plan: "A need exists for a companion trailer for the High-Mobility Multipurpose Wheeled Vehicle (HMMWV), which provides improved off-road mobility and increased payload over the present M101 series 3/4 ton trailer. The M101 series trailer lacks stability because its wheels do not have the same track width as the HMMWV, and its suspension does not provide adequate wheel travel or ride dynamics. Thus, in soft and rough terrain, the trailer has the propensity to overturn, even at low speeds. The current M101 series trailers do not provide enough payload or curb capacity to prevent it or its prime mover from being overloaded. The introduction of the HMT may reduce the number of vehicles and trailers needed to perform unit missions."

The following required characteristics for the HMT apply directly to the braking analysis:

- 1) Be capable of being towed by the HMMWV IAW the operational mode summary/mission profile (OMS/MP) (See Appendix A, O&O, page A-3, para 4.a).
- 2) Have a payload of 1,500-2,500 pounds and not exceed the towed load allowance (3,400 lbs) for the Group I/II (M998/M1037) variants. A desired characteristic is that the trailer will meet the towed load allowance (4,200 lbs) of the Group III (Heavy HMMWV) variant (See Appendix A, O&O, page A-3, para 4.b).
- 3) Have parts, fittings, and tools compatible with the Group I/II variants (See Appendix A, O&O, page A-4, para 4.i).
- 4) Be equipped with service or surge brakes and an independent, manually operated parking brake (See Appendix A, O&O, page A-4, para 4.j)."
- 5) At Gross Combined Weight (GCW), be capable of negotiating a 40

percent side slope and ascending/descending 40 percent longitudinal grades without slipping or overturning. The parking brake should hold the HMT at GVW on a 30 percent longitudinal grade. (See Appendix F, Draft ROC, Appendix 1, page F-9, para 1.b.13).

5.2. Analysis

5.2.1. Force Analysis. A free body diagram (Figure 5-1) was used to analyze the forces which exist on the HMMWV and HMT as they descend a slope. Considering the HMMWV alone, the sum of the forces in the y direction

$$[\text{SUM}]F_y = 0$$

$$[\text{SUM}]F_y = N_v - W_v \cos(\beta) = 0$$

$$N_v = W_v \cos(\beta) \quad (\text{eq 1})$$

where

N_v = HMMWV normal force

W_v = HMMWV weight

β = slope angle

The weight on the front and rear wheels of the HMMWV is not usually the same. This is not a factor if the brakes lockup the wheels (no rotation), but is if they are not locked up. The normal forces on the front and rear wheels of the HMMWV are given by

$$N_{vf} = W_{vf} \cos(\beta) \quad (\text{eq 2})$$

$$N_{vr} = W_{vr} \cos(\beta) \quad (\text{eq 3})$$

where

N_{vf} = HMMWV normal force on front wheels

N_{vr} = HMMWV normal force on rear wheels

W_{vf} = HMMWV weight on front wheels

W_{vr} = HMMWV weight on rear wheels

These equations (eq 2&3) are used later in this analysis when braking without lockup is considered.

The sum of the forces in the y-direction for the trailer yields

$$[\text{SUM}] F_y = 0$$

$$[\text{SUM}]F_y = N_t - W_t \cos(\beta) = 0$$

$$N_t = W_t \cos(\beta)$$

where

N_t = trailer normal force

W_t = trailer weight

The sum of the forces acting in the x direction for the whole system, referred to as the pulling force, is

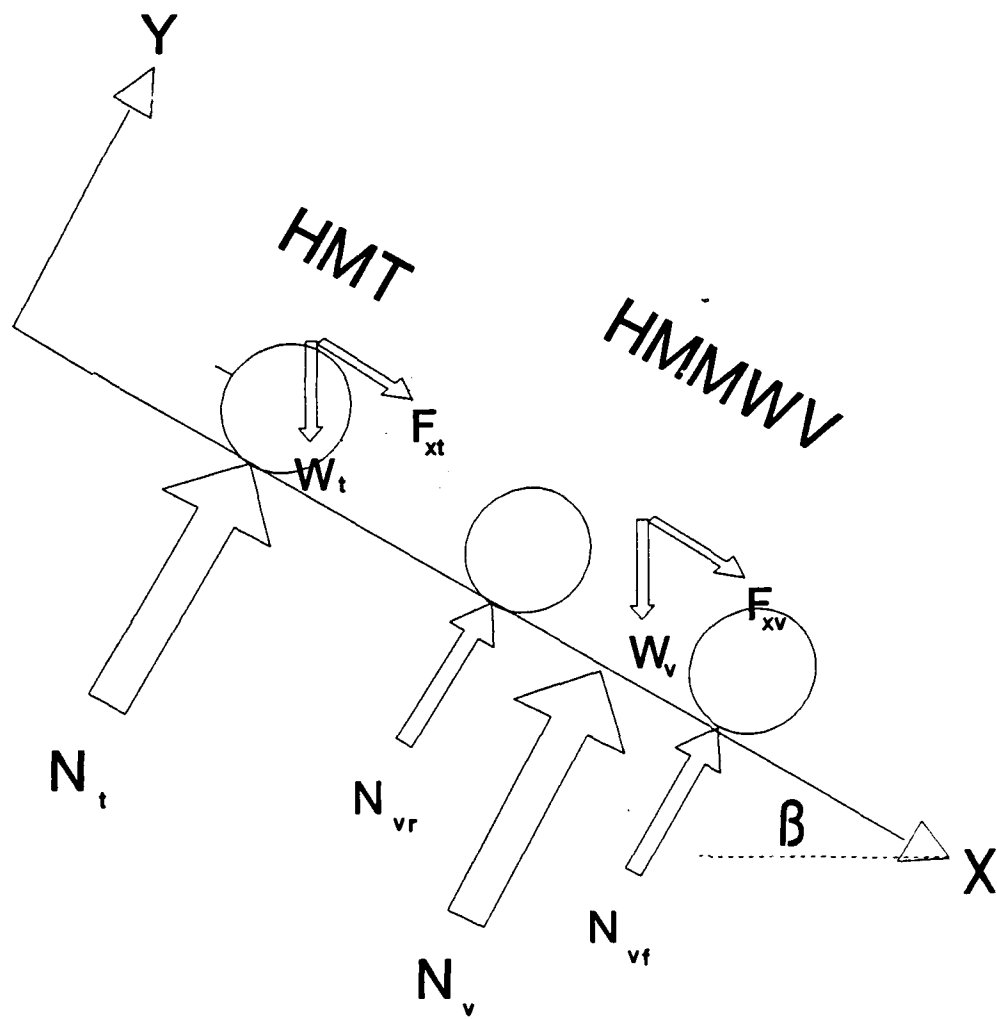

Figure 5-1
 Free Body Diagram - HMMWV and HMT

Note: Force vectors shown are not to scale

$$F_x = F_{xt} + F_{xv}$$

$$F_x = W_t \sin(\beta) + W_v \sin(\beta) = (W_t + W_v) \sin(\beta) \quad (\text{eq 4})$$

It is very important to note that the F_x shown in Figure 5-1, is for a system that is traveling down hill. F_x would be negative for a system traveling up hill and zero on a flat surface.

5.2.2. Predicting Lockup.

5.2.2.1. HMMWV Brake System Information⁴. The following data was provided by Kelsey-Hayes, manufacturer of the HMMWV brakes.

Area of Brake Pad Lining= 56.13 cm²
 Axle to Wheel Gear Ratio= 1.92:1
 Effective Radius of Rotor= 103.9 mm
 Caliper Piston Head Diameter= 66 mm
 Pressure on front and rear brakes are the same up to 400 psi, after which the ratio of front to back is= 1:0.27
 Pad to Rotor Coefficient (μ_p) of Friction= 0.46 (this is an average value)

5.2.2.2. Technical Manual Drawings. Figures 5-2 through 5-5 are drawings taken from the Technical Manual⁵ for the HMMWV and are provided to clearly show the relationship of the brake to the wheel. Figure 5-2 shows the rotor (item 10) and axle. Figure 5-3 shows the axle gear (item 20) as it relates to the wheel gear box (item 3). Figure 5-4 shows the internal mechanics of the wheel gear box. The axle gear pointed out in Figure 5-3 (item 9 in Figure 5-4) meshes with the wheel box gear (item 28) creating the gear ratio of 1.92:1, provided by Kelsey-Hayes. Figure 5-5 shows the brake assembly.

5.2.2.3. Predicting Brake Lockup. The braking effect is created by the application of a force on the brake peddle which generates a pressure on the caliper piston. This pressure forces the brake pad against the rotating rotor. The pad/rotor contact creates a brake torque. This torque is dependent on the radial arm of the pad/rotor contact, the caliper pressure, and the coefficient of pad/rotor friction (See Figure 5-6).

If we consider the front axle of the HMMWV, the braking torque generated, T_b , is given by the equation

$$T_b = 2 (1.92 \mu_p F_p r_r)$$

where

F_p - force on pads created by caliper piston
 r_r - effective radius of the rotor
 μ_p - coefficient of friction between pad and rotor

There is a factor of 2 is because there are 2 brake assemblies on the axle. The factor 1.92 is the gear ratio discussed in sections 5.2.2.1. and 5.2.2.2. The tractive torque, T_t , of the wheel is given by the equation

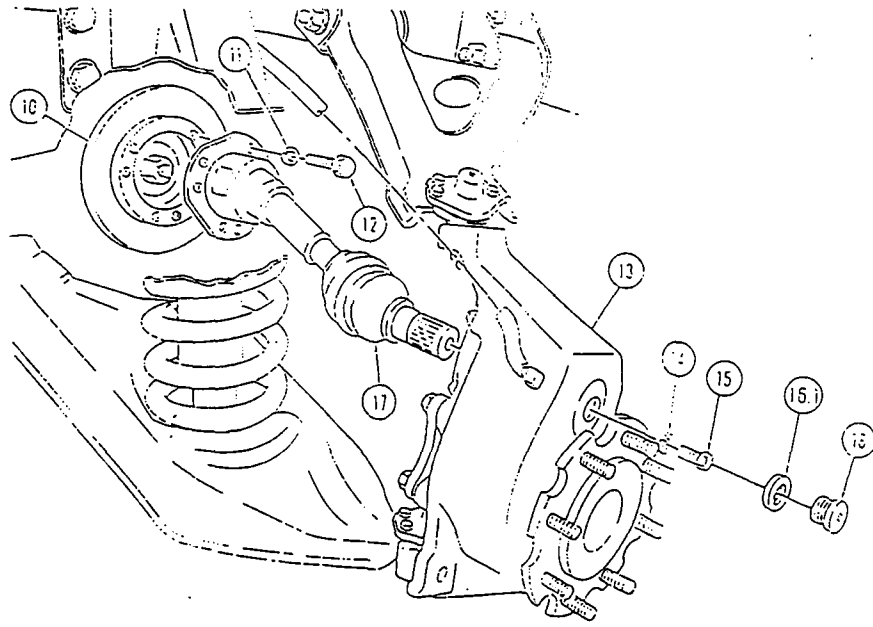

Figure 5-2
Axle Rotor Relation

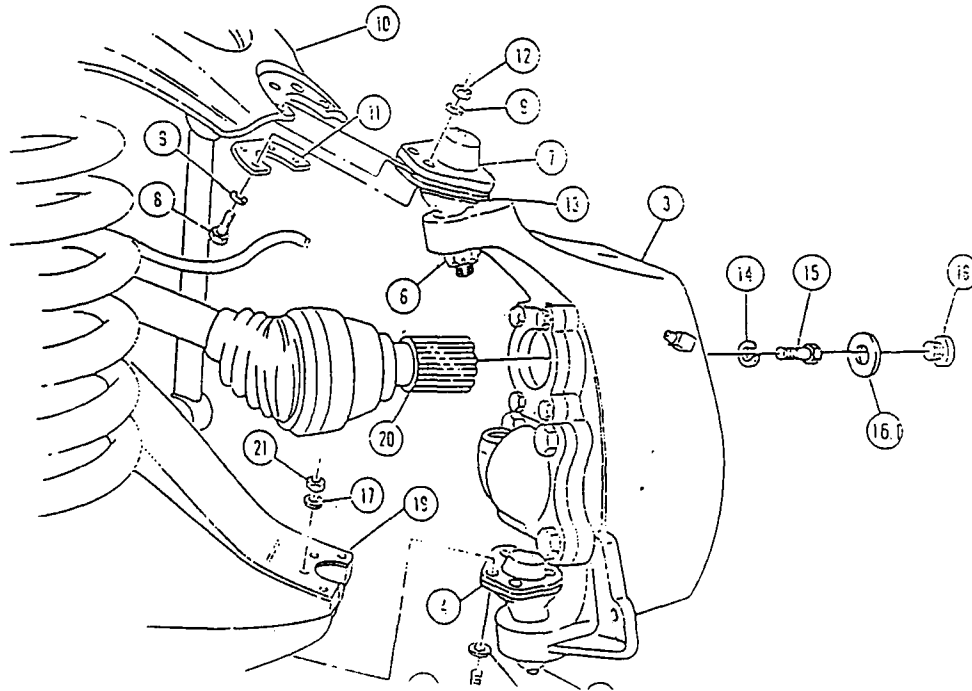

Figure 5-3
Axle Gear and Wheel Gear Box

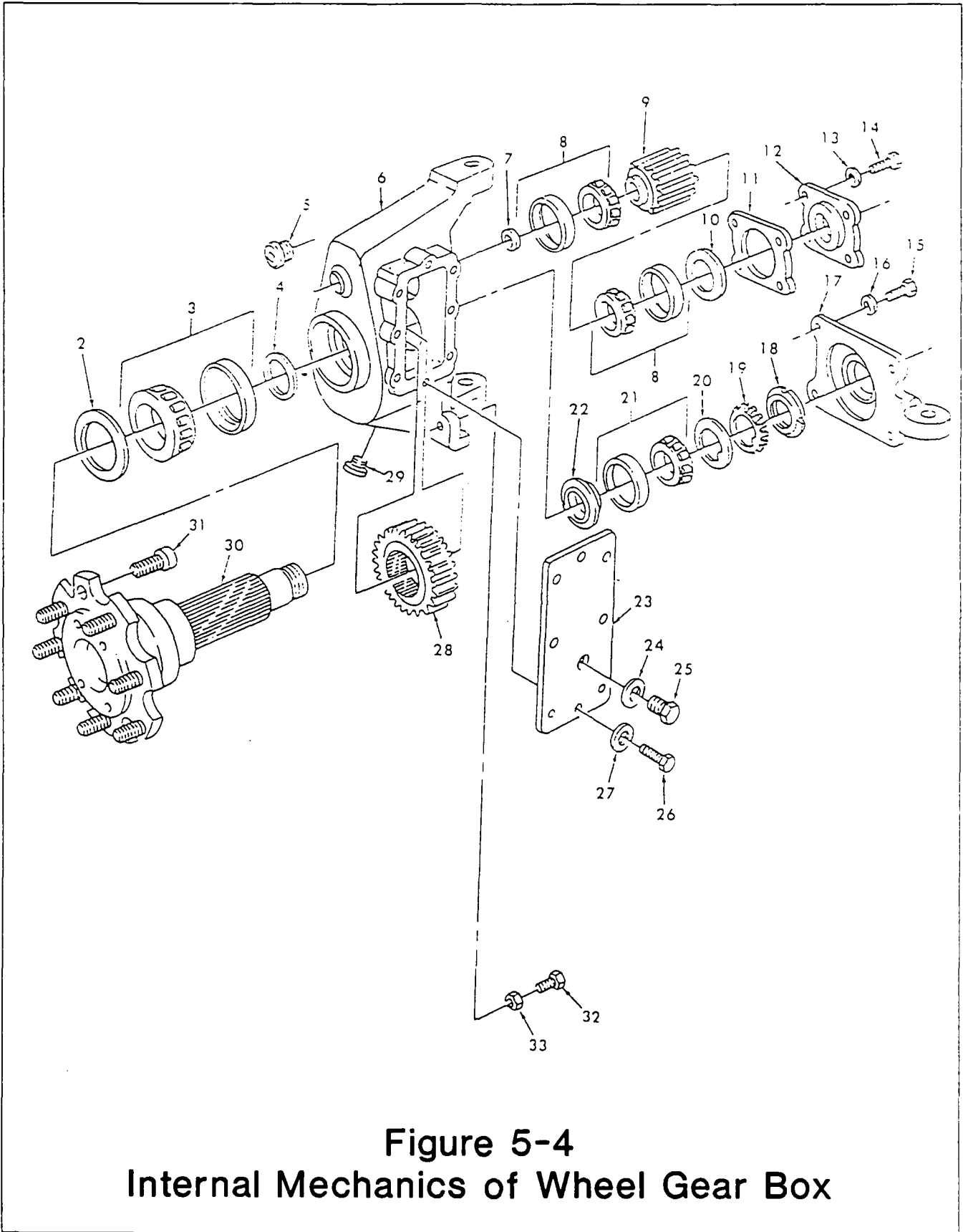

Figure 5-4
Internal Mechanics of Wheel Gear Box

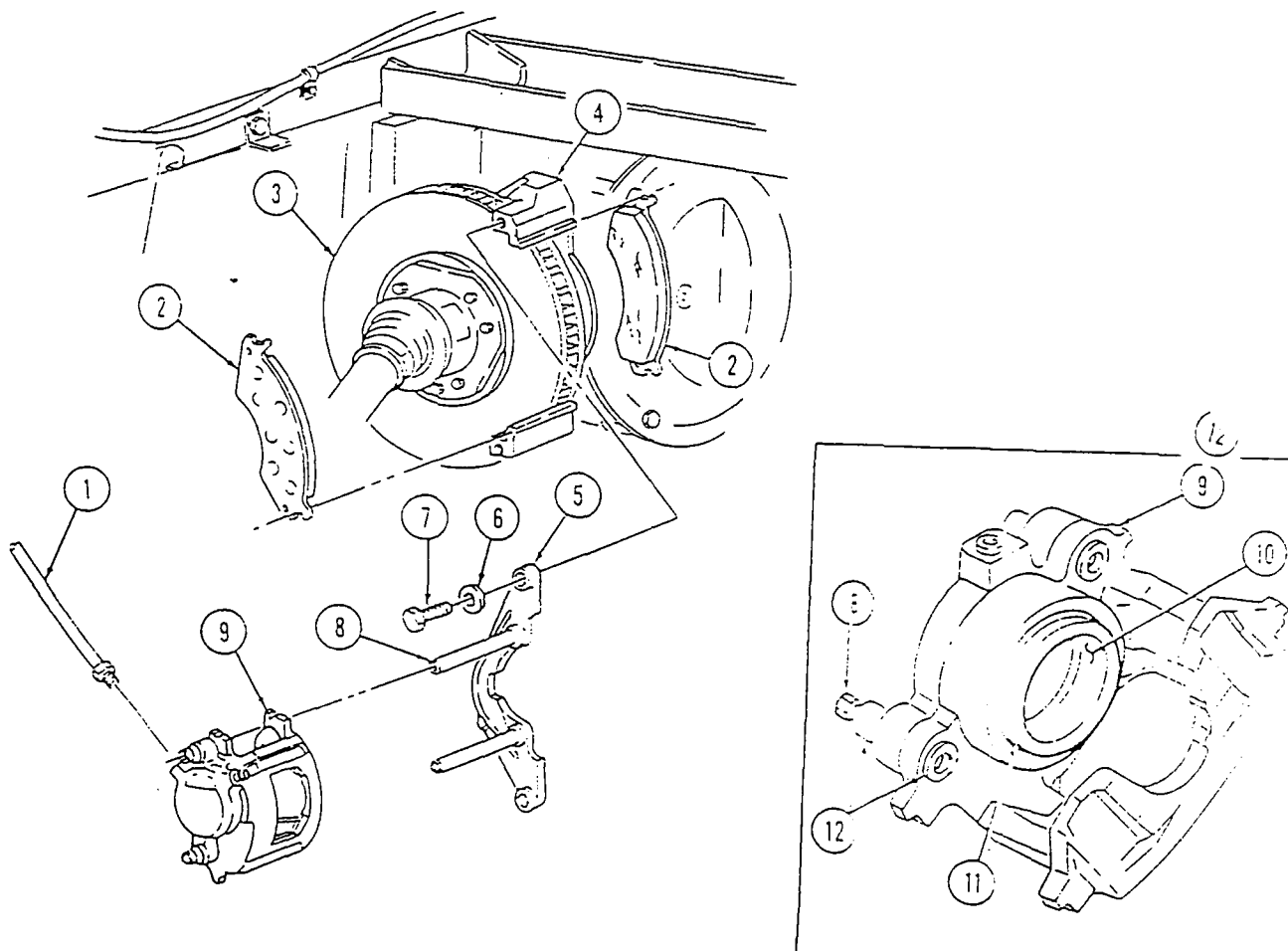

Figure 5-5
Brake Assembly

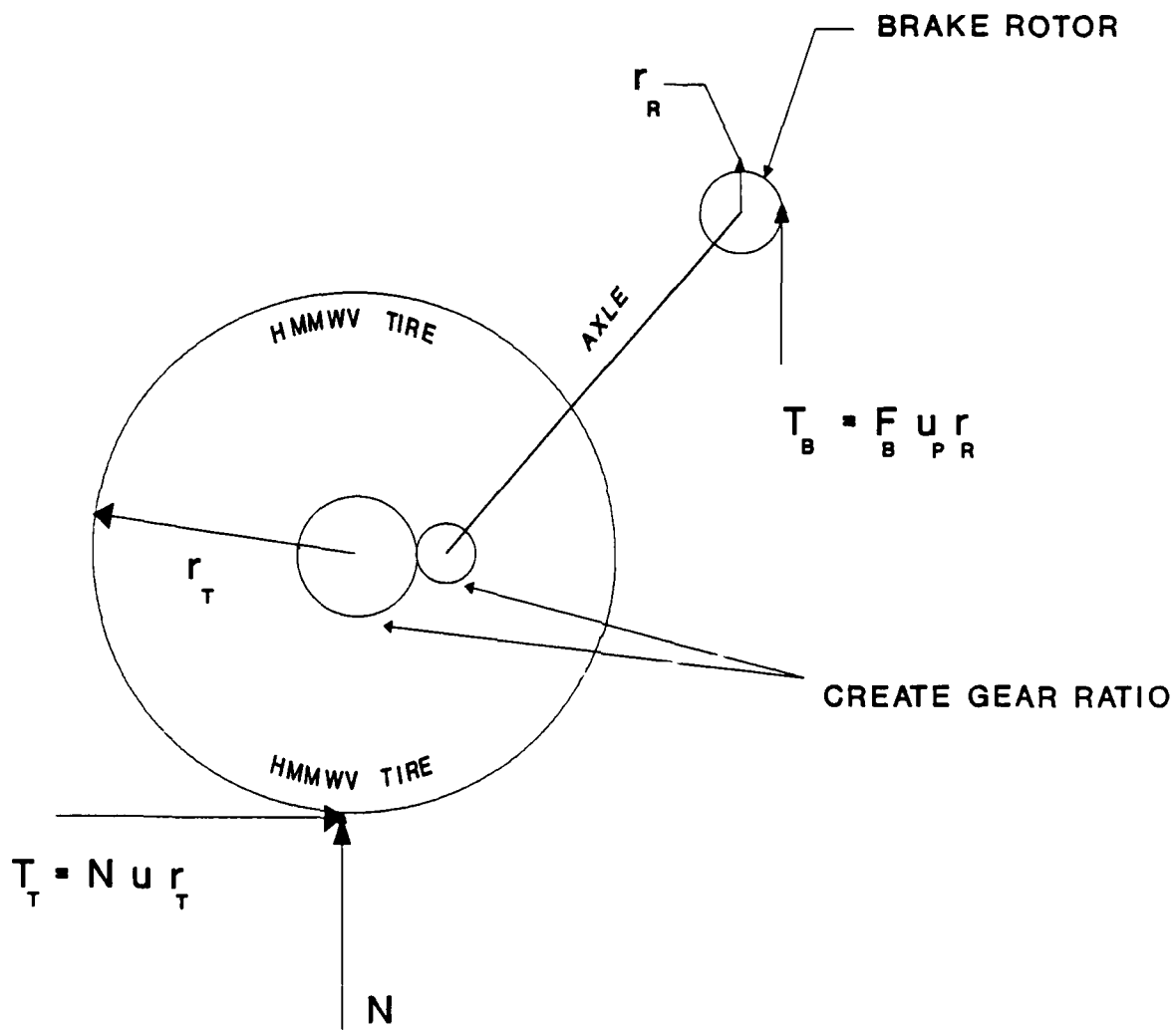

Figure 5-6
Free Body Diagram - HMMWV Tire/Caliper

$$T_t = 2(\mu N_v r_t)$$

Substituting equation 1 for N_v , the equation becomes

$$T_t = \mu r_t W_v \cos(\beta)$$

r_t = tire radius

Lockup occurs when the braking torque is greater than the tractive torque.

$$T_b \geq T_t \quad \text{Lockup}$$

therefore when

$$T_b < T_t \quad \text{No Lockup}$$

5.2.3. Braking With Lock-up, Surge Brake Inactive. There are four forces at work on the vehicle as it brakes; friction, gravity, rolling resistance, and air resistance. Due to its minimal effect, air resistance was neglected. The rolling resistance is not a factor when the wheels of the HMMWV are locked-up. The force due to gravity is a function of the slope and is the sum of the forces in the x direction (ref eq 4). Referring to the kinetic diagram, Figure 5-7, the force due to friction, F_f , when the wheels are lockedup, is given by the equation

$$F_f = \mu N_{vr} + \mu N_{vf}$$

$$F_f = \mu N_v$$

Balancing the forces of the kinetic diagram yields

$$F_{\text{resultant}} = F_f - F_x = ma$$

In order to account for the inertial force of the rotating parts in the system. It was found that a factor of 1.04 should be used², therefore incorporating this and the equations for the frictional and gravitational forces, $F_{\text{resultant}}$ becomes:

$$1.04 ma = \mu N_v - [W_t \sin(\beta) + W_v \sin(\beta)] \quad (\text{eq 6})$$

Substituting equation 1 for N_v , and the equation for mass:

$$m = (W_v + W_t) / g$$

where g is the gravitational constant, equation 6 becomes

$$1.04 \frac{W_v + W_t}{g} a = \mu W_v \cos(\beta) - (W_t + W_v) \sin(\beta)$$

dividing both sides by $(W_v + W_t) / g$ and solving for "a" yields

$$a = 1/1.04 \left[\frac{W_v}{W_v + W_t} g \mu \cos(\beta) - g \sin(\beta) \right]$$

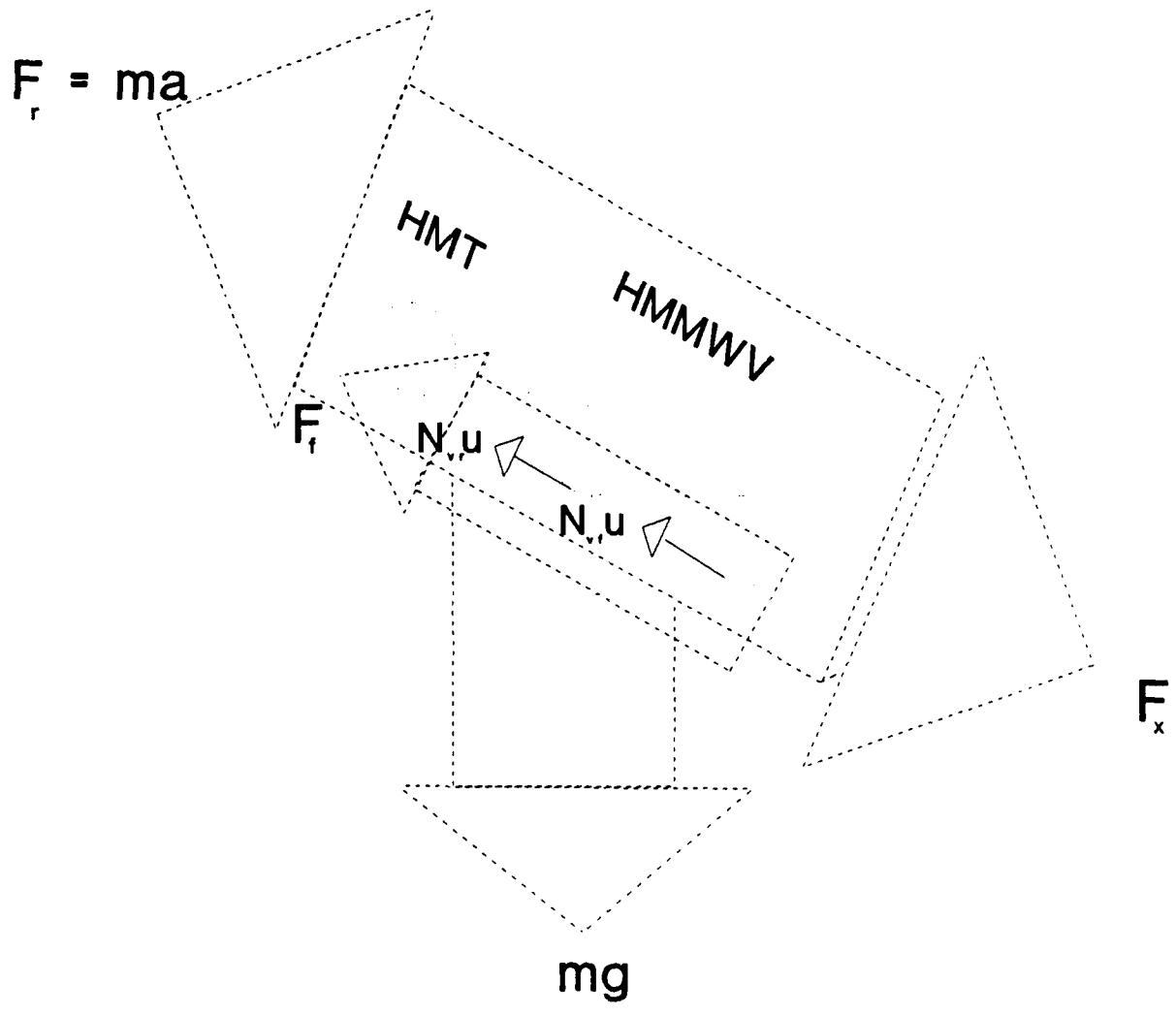

Figure 5-7
 Kinematic Diagram - HMMWV and HMT
 Note: Force vectors are not to scale.

If we let

$$k = W_V / (W_V + W_T) \quad (\text{eq 7})$$

the equations simplifies to

$$a = (g/1.04) [k\mu \cos(\beta) - \sin(\beta)] \quad (\text{eq 8})$$

If the system were traveling up hill, gravity works with the braking effect, and $\sin(\beta)$ would be positive. Remember this is the total deceleration if the tires are "locked up" (not rotating) and the trailer's surge brake is inoperable.

5.2.4. Energy Analysis. A Conservation of Energy Method³ was used to verify equation 8.

$$\text{Energy}_{\text{in}} = \text{Energy}_{\text{out}}$$

$$\text{Kinetic Energy} + \text{Potential Energy} = \text{Frictional Energy}$$

$$\frac{1}{2}mv^2 - mgh = \mu N_V d$$

v = initial velocity

g = gravitational constant

h = change in height

d = distance over which frictional force is applied

μ = coefficient of tire/road adhesion

The height h is related to the distance s by

$$h = d \sin(\beta)$$

Potential Energy is positive when the system is traveling down hill and negative when traveling up hill. Incorporating weight and the slope angle the equation becomes

$$\frac{(W_V + W_T)}{2g} v^2 - (W_V + W_T) d \sin(\beta) = \mu W_V \cos(\beta) d$$

dividing by $W_V + W_T$ and using k (reference equation 7) the equation becomes

$$v^2 / (2g) + d \sin(\beta) = k \mu d \cos(\beta)$$

solving for the distance d

$$d = \frac{v^2}{2g [k \mu \cos(\beta) - \sin(\beta)]} \quad (\text{eq 9})$$

Recognizing that the denominator of equation 9 is "2a" less the factor 1.04, defined in equation 8, therefore the equation for braking distance d becomes

$$d = \frac{v^2}{2(1.04)a} \quad (\text{eq 10})$$

This is the distance it takes for the system to come to a stop. Because d cannot be negative or more specifically the denominator of equation 10;

$$\mu \geq \frac{\sin(\beta)}{k \cos(\beta)} \geq (1/k) \tan \beta$$

This is to say that given a slope angle and weight configuration, there exists a minimum coefficient of tire/surface friction that must be present to achieve a braking effect. Otherwise the system would continue to slide until the slope or the coefficient of friction changed. The energy method reinforces the mechanical solution by deriving the same rate of deceleration (denominator of eq 10).

5.2.5. Braking Without Lockup. When the tires are not locked up, the energy of the vehicle is absorbed by the brakes through friction. A ratio of 5.9 between brake peddle force, applied by the vehicle operator, and caliper pressure was determined experimentally from a test performed during the Validation Brake Test at General Motors Proving Grounds. The test utilizes a Roll Transducer Pad (RTP) which measures the brake bias of a braking vehicle with respect to each tire and the brake peddle force (See Appendix C).

As the HMMWV/HMT System travels, it creates kinetic energy, and if on a slope, potential energy. When the brakes are applied, the kinetic and potential energies are converted (absorbed) by pad/rotor frictional energy. A small amount of energy is also absorbed by the roll resistance of the tires. An energy balance yields:

$$\frac{1}{2}mv^2 \pm mgh = F_b \mu_p d_r + d_r \mu_r mg \quad (\text{eq 11})$$

where,

$\frac{1}{2}mv^2$ = kinetic energy
 m = mass of the system
 v = velocity of the system

mgh = potential energy
 m = mass of the system
 g = gravitational constant
 h = vertical distance

$F_b \mu_p d_r$ = frictional energy
 F_b = force between pad and rotor
 μ_p = coefficient of pad/rotor friction
 d_r = radial distance over which the frictional force acts

$$d_r \mu_r mg = \text{roll resistance energy}$$

μ_r = coefficient of roll resistance
 = 0.02
 mg = total weight of the HMMWV/HMT system
 d_r = radial distance

The potential energy is positive on the left side of the equation when the system is traveling downhill and negative when uphill. Also, when the surge brake is inactive the mass, m , is the mass of the HMMWV and trailer. But, when the trailer's surge brake is active, the mass is that of the HMMWV alone. This is because, when the trailer's brake is inactive, the HMMWV's brakes must absorb the energy of the trailer. But, when the trailer's brake is active, the braking effect of the HMMWV and trailer must be considered separately. Braking with an active surge brake is considered in a later section. The radial distance d_r is related to the radius of the rotor and the angle ϕ (phi) the rotor turns through by

$$d_r = \phi r_r \quad (\text{eq 12})$$

The radial distance the HMMWV tire travels is related to the angle ϕ the rotor turns by a factor of 1/1.92 due to the gear ratio, therefore the linear distance, d , the HMMWV/HMT system travels

$$d = (1/1.92) \phi r_t \quad (\text{eq 13})$$

$$r_t = \text{tire radius}$$

The vertical distance h is directly proportional to the linear distance d by

$$\begin{aligned}
 h &= d \sin(\beta) \\
 h &= (\phi r_t) \sin(\beta)
 \end{aligned} \quad (\text{eq 14})$$

$$\beta = \text{slope angle}$$

Incorporating equations 12, 13 and 14 into equation 11 yields

$$\frac{1}{2}mv^2 \pm mg(1/1.92)r_t\phi \sin(\beta) = F_b \mu_p \phi r_p + \phi \mu_r mg r_r$$

solving for ϕ

$$\phi = \frac{\frac{1}{2}mv^2}{\mu_p F_b r_r \pm mg (1/1.92) r_t \sin(\beta) + \mu_r mg r_r}$$

This is the radial angle the rotor must turn to absorb the energy of the HMMWV/HMT system. Once ϕ is known, the linear braking distance, in feet, is calculated using equation 13

$$d_e = (1/1.92) r_t \phi$$

For clarity, d_e is called the energy braking distance.

5.2.6. Braking with an Effective Surge Brake. The model has the capability to predict the braking distance of the system with a functional surge brake. A surge brake consists of a brake cylinder mounted to the tongue of the trailer, and a drum brake at either wheel (See Figure 5-8). The brake cylinder contains a piston whose connecting rod forms the lunette of the trailer, which hooks into the HMMWV pintle hitch. As the HMMWV decelerates, due to braking, the forward momentum of the trailer pushes the lunette against the pintle hitch. This action forces the piston in the trailer's brake cylinder to push brake fluid into the drum cylinders applying the shoes to the drum, creating a braking effect. The force with which the HMT's brake cylinder is compressed, F_S , is given by

$$F_S = m_t a$$

where

$$\begin{aligned} m_t &= \text{mass of the trailer} \\ a &= \text{deceleration of the HMMWV} \end{aligned}$$

The following was used to determine the effect of the surge brake:

$$\begin{aligned} \text{Surge brake pad coefficient } \mu_{sp} &= 0.3^6 \\ \text{Effective pad radius } r_s &= 6 \text{ [in]} \end{aligned}$$

The surge brake produces a brake torque, T_S where

$$T_S = 4 F_S \mu_{sp} r_s$$

A factor of 4 accounts for two drum brakes on the trailer's axle with 2 brake shoes. Dividing the trailer brake torque by the tire radius, which is the same as the HMMWV, gives the force with which the trailer is pulling on the HMMWV.

$$F_t = T_S / r_t \quad (\text{eq 15})$$

Once the force with which the trailer is pulling on the HMMWV is known, it must now be related to the HMMWV's braking effect. This is accomplished by calculating the HMMWV's and trailer's decelerations. When the HMMWV's brakes are locked up, its rate of deceleration is given by equation 8:

$$a = (g/1.04) [k\mu \cos(\beta) \pm \sin(\beta)]$$

If the HMMWV's brakes are not locked, its deceleration must be calculated using the relationship of

$$a = v^2 / 2d_e$$

where v is the initial velocity and d_e the energy braking distance calculated from ϕ . The trailer's deceleration depends on whether the HMMWV's brakes are locked or not. If locked, the deceleration is

$$a_t = F_t / m_t$$

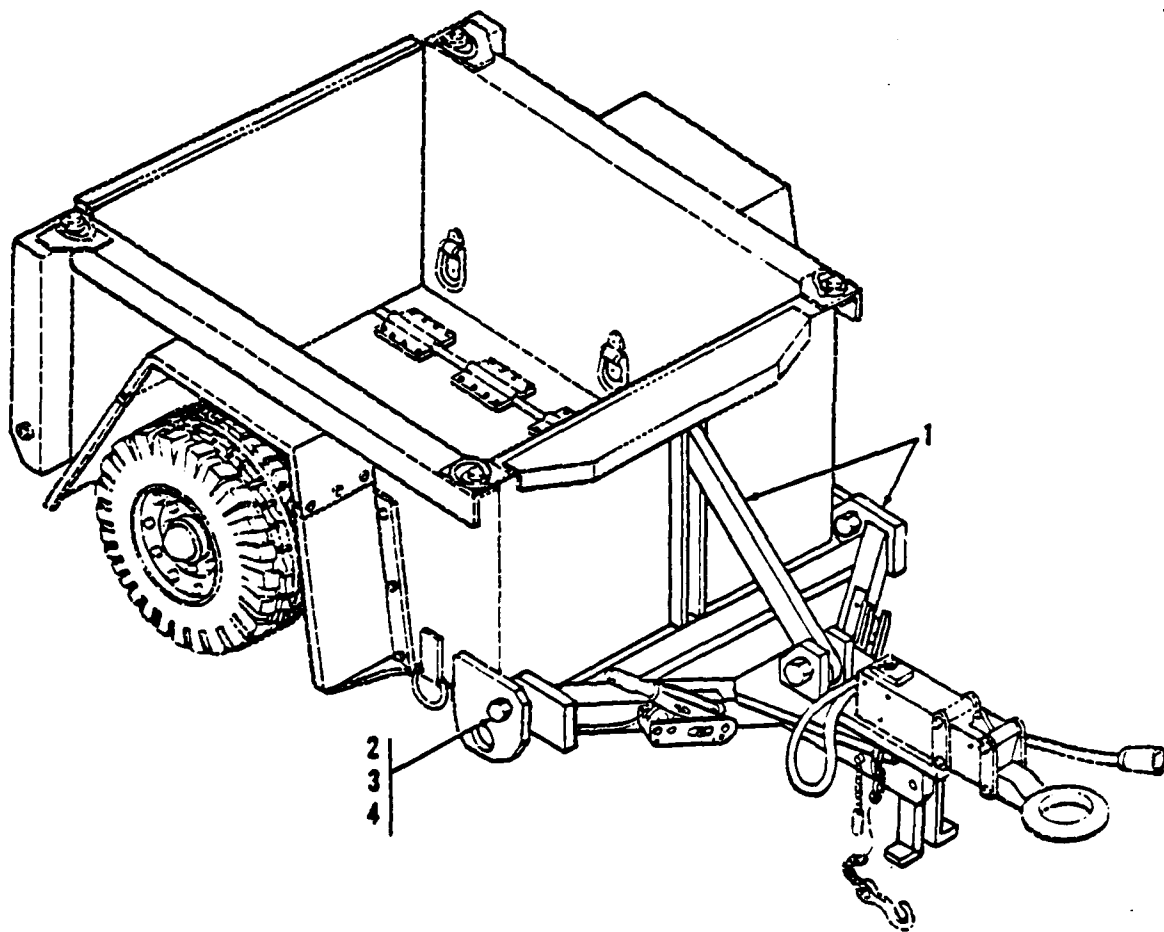

Figure 5-8
XM1071 Trailer used for the Model Validation Test

where m_t = mass of the trailer
But, if the HMMWV is not locked up, the trailers deceleration is

where $a_t = F_t/m$
 m = mass of the trailer and HMMWV

The change in mass is necessary because of the approach used in the energy analysis where the mass of the trailer is not included if the surge brake is active. The total deceleration of the HMMWV/HMT system is

$$a_{total} = a + a_t$$

With the total deceleration known, the braking distance can be calculated from the following relationship

$$d = v^2/2a_{total}$$

5.2.7. Coefficient of Tire/Road Adhesion. Values of static tire/road adhesion were determined through research (ref Table 5-1)⁷

5.2.7.1. Kinetic Friction. The coefficient of kinetic friction is typically 25% smaller than the static coefficient of friction.⁸ Once a body is sliding, very often a smaller force is required to keep it moving at a constant velocity than is required to start it moving in the first place. This force, divided by the load, is called the kinetic coefficient of friction. This is not quite true for rubber, which is an exceptional material in that its dynamic coefficient of friction increases with increased speed for low speeds⁹. This must be considered when selecting a tire/surface coefficient of friction.

5.3. Model

The model was made using a Lotus 1-2-3 spreadsheet found in Appendix A. The spreadsheet is designed to be user friendly, meaning it can be used by an individual with a minimal knowledge of Lotus 1-2-3. The spreadsheet is divided into seven sections;

- 1) User Dependent Variables
- 2) Results
- 3) Non-Dependent Variables
- 4) Weight Dependent Variables
- 5) Weight and Grade Dependent Variables
- 6) Braking Variables
- 7) Coefficient of Road/Surface Friction Dependent Variables

The spreadsheet is arranged in order of increasing dependence in that, the farther down in the spreadsheet a variable appears, the more dependent it is on the variables above it.

5.3.1. User Dependent Variables

Coefficient of Tire/Surface Friction

Table 5-1
 Values of Static Tire/Surface Coefficients of Friction

<u>SURFACE</u>	<u>CONDITION</u>	<u>μ</u>
ASPHALT OR CONCRETE	DRY	0.8-0.9
CONCRETE	WET	0.8
ASPHALT	WET	0.5-0.7
GRAVEL		0.6
EARTHEN ROAD	DRY	0.68
EARTHEN ROAD	WET	0.55
SNOW	HARD PACKED	0.2
ICE		0.1

Constant Initial Velocity [MPH]
Slope [deg]
Brake Peddle Force [lbs]
Is the Surge Brake Active? [yes, no]
Traveling Up or Down Hill? [up, down]
Traveling in Reverse [yes, no]

These variables are input by the user. The user can pick a coefficient of tire/surface friction between 0-1.0 in increments of 0.01. This specified coefficient tells the computer that the user wants the corresponding braking distance. Initial velocity and slope are self explanatory. The brake peddle force is the force with which the driver pushes on the peddle with his/her foot. A driver braking in a panic stop can generate as high as 450 pounds force, according to the validation test. The last three variables are questions and require the input of a number signifying an answer to the question; i.e., is the surge brake active [yes-1, no-0]? By entering a 0 signifies that the trailer surge brake is inactive. If the vehicle is traveling in reverse, the trailer surge brake is ineffective. If the user inputs that the system is in reverse, the model automatically assumes the surge is inactive; the user does not have to input that the surge is inactive also. Whether or not the vehicle is traveling up or down hill is critical in determining the rate of deceleration. When traveling up a hill, gravity assists braking. The opposite is true when traveling down hill. Also, whether or not the system is traveling up or down a hill is critical to the amount of force that is applied to the surge brake cylinder.

5.3.2. Results

Wheel lockup occurred [1=yes, 0=no]
Braking distance [ft]

Once the user has filled in the user dependent variables, a macro can be invoked. A macro is a miniprogram placed inside the spreadsheet. Its purpose is to simplify a complicated set of steps. When the user has adjusted the user dependent variables and would like to see the corresponding braking distance, he need only push simultaneously the alternate and letter A key. This will invoke the macro, which tells the computer to scan the coefficient of friction column until it finds the value the user had specified. It then reads whether the trailer's wheels are locked up and the corresponding braking distance. It finishes by copying this data into the results section of the spreadsheet. This can be repeated whenever the user desires, from anywhere in the spreadsheet, allowing him easy multiple iteration.

5.3.3. Independent Variables.

Trailer Weight
Total HMMWV Weight (M998)
Front Axle [lbs]
Rear Axle [lbs]
Effective Area of Brake Pad [in²]

Gear Ratio
Effective (Eff.) radius HMMW Rotor [in]
Effective (Eff.) Radius Trailer Rotor [in]
Caliper Piston Diameter [in]
HMMW Brake Pad Coefficient
Trailer Brake Pad Coefficient
Tire Dia. [in]
Gravitational Constant [ft/s²]

A nondependent variable means that the value is constant and not dependent on any other value in the spreadsheet. Most of these values are self-explanatory and were defined by Kelsey-Hayes (sec 5.2.2.1.). The HMMW weight, front and rear axles, can be adjusted at the users discretion.

5.3.4. Weight Dependent Variables.

Multiplying Factor
Total Mass [slugs]
HMMW Mass [slugs]
Trailer Mass [slugs]
Total Weight [lbs]
K

The multiplying factor is dependent on whether the system is traveling up or down hill and is used to simplify later equations. The other variables in this section are directly dependent on the trailer and HMMW weights and will be automatically adjusted when the weights are changed. The value k is a ratio defined in section 5.2.2.

5.3.5. Weight and Grade Dependent Variables.

Trailer Normal Force [lbs]
Trailer Pull Force [lbs]
HMMW Normal Force
 Front Axle [lbs]
 Rear Axle [lbs]
HMMW Pull Force
Total Pull Force [lbs]
HMMW Traction Torque Constant [lb in]

All of the normal and pull forces (See section 5.2.1.) are dependent upon the grade (slope angle) and weights. Whenever either of these two values are changed the normal and pull forces are automatically adjusted. The HMMW traction torque constant (See section 5.2.2.3.) must be multiplied by the existing coefficient of tire/surface friction to be the actual traction torque.

5.3.6. Braking Variables.

Brake Pressure [psi]

Brake Force:
 Front Wheels [lbs]
 Rear Wheels [lbs]
 HMMWV Braking Torque [lb in]
 Phi Negative Potential [rad]
 Phi Positive Potential [rad]
 Applicable Phi [rad]
 Energy Distance [ft]

The variables in this section are primarily dependent on the brake peddle force being applied by the vehicle operator and non-dependent variables. The brake pressure is directly proportional to the brake peddle force. The braking force is the force at the pad/rotor interface, on the front and rear axles, created by the brake force. The braking torque is the total output torque of all four wheels of the HMMWV at the tire/surface interface. Phi is the number of radians of rotation the rotor will turn, with the brake pad contact, to absorb the energy of the HMMWV/HMT system (See section 5.2.5). Phi negative potential is the number of radians required if the slope that the system is on is negative (traveling down hill). Phi positive potential is the number of radians required if the system were on a positive slope (traveling up hill). Applicable phi is the phi used for the present conditions. Separation of these equations was necessary because of their size and number of IF statements. The energy distance is the linear braking distance calculated using applicable phi.

5.3.7. Coefficient of Tire/Surface Friction Dependent Variables.

Coefficient of Tire/Surface Friction
 Lockup Prediction- 1=yes, & 0=no
 HMMWV Deceleration [ft/s²]
 Possible Trailer Brake Force [lbs]
 Trailer Braking Force [lbs]
 Trailer Deceleration [ft/s²]
 Braking Distance [ft]
 Coefficient of Tire/Surface Friction [Repeated for Convenience]

All of these variables are dependent on the coefficient of tire/surface friction which is varied on the spreadsheet from 0 to 1.0, in increments of 0.01. The coefficient is varied down the spreadsheet as the other variables to the right are calculated. This allows the user to visually observe braking characteristic changes as the coefficient is varied. Visual observation was critical to fault diagnosis when creating the model, because as the coefficient is increased, certain characteristics are expected to change. For example, the HMMWV brakes are locked up to a specific coefficient. With the visual presentation, the user can determine this value. Also the coefficient of friction is rarely constant; therefore, with a display of all possible coefficients, the user can read the braking distance for a specified range of coefficients. The lockup prediction is a yes/no calculation; a "1" represents lock up and a "0" no lock up. The HMMWV deceleration is dependent on whether the brakes are or are not locked up (See sections 5.2.2. & 5.2.5.). The possible and applicable trailer braking forces are the same if the surge brake is

active. When the surge is inactive, the applicable force is zero. It is repeated because it requires a double "if" statement (See section 5.2.6). The trailer deceleration is calculated from the trailers braking force, in order to relate it to the HMMWV's deceleration. The braking distance is the overall braking distance of the system.

5.3.6. Macro. The spreadsheet contains a macro. A macro is a program inside the spreadsheet which when activated executes a set of key strokes. After the user configures the user dependent variables, a macro, activated by pressing the alternate and "A" key simultaneously, tells Lotus 123 to scan the coefficient of friction column until it finds a match, to the coefficient of friction, specified by the user. After finding the match it reads the value in the lockup prediction and braking distance column, copying the values to the results section at the top of the spreadsheet.

LIST OF REFERENCES

- 1 MIL-HANDBOOK 759-A, Human Factors Engineering Design for Army Materiel, Para 2.4.3.1, 31 Dec, 1985.
- 2 Taborek T.J., "Mechanics of Vehicles- Dynamics of Braking," Machine Design, Penton Publication, Cleveland, 1957
- 3 Tipler P.A., "Physics," Second Edition, Worth Publishers, Inc., 444 Park Ave. South, New York, NY 10016, 1982.
- 4 Mr. Paul Smith, Project Engineer, Kelsey-Hayes, Romulus, Michigan, (313) 941-2000, December 1, 1989.
- 5 Technical Manual TM9-2320-280-20.
- 6 Bosch, "Automotive Handbook," Second Edition, Robert Bosch GmbH, Postfach 50, D-7000, Stuttgart 1, 1986.
- 7 Transportation Analysis Group, "Material on Steering of Tracked Vehicles," Davidson Laboratory, April 1977
- 8 Hibbeler R.C., "Engineering Mechanics- Static and Dynamics," Fourth Edition, Macmillian Publishing Co., 866 Third Ave, New York, NY 10022, 1986.
- 9 Newcomb T.B., "Automotive Brakes and Braking Systems," Motor Manuals, Volume 8, Robert Bentley Inc., 872 Massachusetts Ave., Cambridge, MA 02139, 1969.
- 10 Weldon H., Test Director, "Final Letter Report Prototype Qualification Test-Government XML071, Desert Mobility Vehicle System (DMVS) Trailer, Volume 1 of 2," U.S. Army Yuma Proving Ground, Yuma, Arizona, April 1986.
- 11 Doan Hien, "Final Report Prototype Qualification Test of XML071, Desert Mobility Vehicle System (DMVS) Trailer," U.S. Army Combat Systems Test Activity, Aberdeen Proving Grounds, MD, July 1988.

DISTRIBUTION LIST

	Copies
Commander Defense Technical Information Center Building 5, Cameron Station ATTN: DDAC Alexandria, VA 22304-9990	12
Manager Defense Logistics Studies Information Exchange ATTN: AMXMC-D Fort Lee, VA 23801-6044	2
Commander U.S. Army Tank-Automotive Command ATTN: ASQNC-TAC-DIT (Technical Library) Warren, MI 48397-5000	10
Commander U.S. Army Tank-Automotive Command ATTN: AMSTA-CF (Dr. Oscar) Warren, MI 48397-5000	1
Director U.S. Army Material System Analysis Activity ATTN: AMXSY-MP (Mr. Cohen) Aberdeen Proving Ground, MD 21005-5071	1
Commander U.S. Army Tank-Automotive Command ATTN: AMCPM-IVL (Mr. Dziewit) Warren, MI 48397-5000	1
Commander U.S. Army Tank-Automotive Command ATTN: AMSTA-CZ (Mr. Jarvis) Warren, MI 48397-5000	1
Commander U.S. Army Tank-Automotive Command ATTN: AMSTA-ZDS (Mr. Sloss) Warren, MI 48397-5000	1

APPENDIX A

HIGH MOBILITY TRAILER OPERATIONAL & ORGANIZATIONAL PLAN 27 November, 1990

OPERATIONAL AND ORGANIZATIONAL PLAN

1. TITLE.

- a. High Mobility Trailer (HMT).
- b. CARDS Reference Number:

2. NEED.

a. A need exists for a companion trailer for the High Mobility Multipurpose Wheeled Vehicle (HMMWV), which provides improved off-road mobility and increased payload over the present M101 series 3/4 ton trailer. The Commander of the 9th Infantry Division documented this need in an Operational Needs Statement dated 28 Oct 87.

b. The M101 series trailer lacks stability during cross country movement because its wheels do not track behind those of the HMMWV and its suspension does not provide adequate wheel travel. Thus, in soft soils and rough terrain, the trailer has the propensity to overturn even at low speeds.

c. The current M101 series trailer in combination with the HMMWV does not provide enough payload and cube capacity. A trailer with greater payload capacity will result in fewer instances of overloading of the prime mover and its associated trailer.

3. THREAT.

a. Threat to be countered. This system will not counter any threat.

b. This system and associated personnel are vulnerable to the spectrum of threat destructive capabilities at all levels of conflict from low through high intensity. Man-made and natural obstacles will impede trailer movement. Destructive capability such as direct and indirect fires, missile effects, antipersonnel and antitank mines, and sabotage explosives can damage the system and harm operators. Nuclear/biological/chemical (NBC) warfare operations can render the system temporarily unusable.

4. OPERATIONAL CHARACTERISTICS. The HMT must:

a. Be capable of being towed by the HMMWV IAW the operational mode summary/mission profile (OMS/MP).

b. Have a payload of 1,500-2,500 pounds and not exceed the towed load allowance (3,400-lbs) for the Group I/II (M998/M1037) variants. A desired characteristic is that the trailer will meet the towed load allowance (4,200-lbs) of the Group III (Heavy HMMWV) variant.

c. The mobility characteristics of the HMMWV must not be degraded by more than $\leq 10-20\%$ when coupled to the HMT at GVW.

d. Operate worldwide in hot, basic, and cold climatic conditions as outlined in AR 70-38 and conditions of rain, fog, haze, snow, and dust.

e. Have a suspension system that provides ride dynamics comparable to the HMMWV.

f. Be capable of fording operations equal to that of the prime mover and be equipped with a drainage plug if needed.

g. Be equipped with service or surge brakes and an independent, manually operated parking brake.

h. Have a pedestal/retractable leg in the tongue so that the trailer, at GVW, can be stowed on the level.

i. Have recessed, internal cargo tiedowns.

j. Be equipped with kit to protect the cargo.

k. Be equipped with a removable tail gate.

l. Be equipped with stabilizer legs, emplaced by the vehicle operator, for stowing on uneven ground.

5. OPERATIONAL PLAN.

a. The HMT will operate throughout the battlefield to include rear, main battle, and covering force areas. The trailer will deploy under any scenario for which the HMMWV deploys. The HMT will primarily interface with all Group I/II/III variant HMMWVs that require the use of a trailer as part of the system in order to accomplish the mission. This includes the carrying of power generation equipment to run communications systems such as Mobile Subscriber Equipment and the pump and hose assemblies for the M17 Lightweight Decontamination System and XM56 Dual Purpose Smoke/Decontamination System.

6. ORGANIZATION PLAN. The HMT will replace, on a one-for-one basis, the M101 series trailer in units currently authorized a 3/4 ton trailer for use with the HMMWV. Organizational level maintenance will be provided by the unit maintenance personnel now supporting the HMMWV/M101 system. The HMT will be found in the following organizations: Field Artillery units (SRC 06 series) for firing batteries, fire direction centers, and AN/TPQ-36 and AN/TPQ-37 radar sections. Quartermaster units (SRC 10447L0) for airdrop equipment. Medical units (SRC 08 series) for treatment squad supplies and Chemically/Biologically

Protected Shelter supplies. Chemical units (SRC 03 series) for pumps and hoses for the M17 Lightweight Decontamination System and XM56 Dual Purpose Smoke/Decontamination System. Signal units for generators and antenna and mast assemblages. Armor (SRC 17 series), Aviation (SRC 01 series), Air Defense (SRC 44 series), and Infantry (SRC 07 series) units for general cargo.

7. SYSTEM CONSTRAINTS.

a. Transportability. The HMT, at GVW, must be internally air transportable with prime mover by C-130 and larger aircraft. The HMT, at GVW, must be transportable without restriction by highway, rail, and marine modes. The trailer must have military standard lifting and tiedown provisions. The HMT, at GVW, must be externally air transportable by UH-60A,L,M models as a single load and CH-47D and CH-53 with the prime mover. The HMT must be capable of low altitude parachute extraction (LAPE) and low velocity airdrop (LVAD) both as a single load and with the prime mover.

b. NBC Survivability. The HMT must be NBC contamination/decontamination survivable.

c. Logistics. The HMT will be supported by the standard Army logistics system. No special tools or test equipment will be required and parts and fittings must be compatible with Group I/II HMMWVs. The HMT electrical system must be compatible with the HMMWV and have Army secure lighting. Routine maintenance procedures will be accomplished at organizational level. Maximum allowable time for individual component replacement at organizational level will not exceed 1 hour.

d. Mobility. The HMT must have the same tracking width as the HMMWV.

e. MANPRINT.

(1) Manpower and Personnel. No additional MOS or manpower requirements are authorized with HMT fielding. Organizational level maintenance will be accomplished by system operators (CMFs 11, 13, 16, 19, 54, 63, 76, 91, 93, and 95). Maintenance at DS/GS level will be accomplished by soldiers in CMF 63. No additional skills or knowledge will be required to operate or support the HMT in the field.

(2) Human Factors Engineering. The HMT will meet applicable industry and government HFE requirements. The soldier machine interface for the system shall facilitate safe and effective operation and maintenance for the representative Army soldier in CMFs 11, 13, 16, 19, 54, 63, 76, 91, 93, and 95 while wearing the full range of Army protective garments (including arctic and MOPP IV). The HMMWV operator must be able to see the trailer in the sideview mirrors.

(3)

(3) System Safety/Health Hazard Assessment. The HMT will overcome the safety concern of overloading the HMMWV and the narrow tracking that causes oscillation and turnover of the M101 series trailers behind the HMMWV. The HMT will not pose a safety or health hazard to operating personnel.

(4) Training Assessment.

(a) Training Concept. The introduction of the HMT into the Army may require changes to the instructional presentation for New Equipment, Non-Resident, Unit, and Institutional Training. The concept of this training will be based upon providing operator, maintainer, and support personnel skills necessary for effective employment of the HMT on the battlefield. The HMT will not require embedded training or training devices.

(b) New Equipment Training (NET). The HMT will require no NET. The transfer of existing skills and knowledge will support operational and maintenance tasks.

(c) Institutional Training. The introduction of the HMT will have minimal impact on institutional training. Training on the HMT will be integrated into existing courses.

(d) Unit Training. The Army envisions only minimal impact on unit training. The transfer of skills and knowledge will support operational and maintenance tasks.

(e) Reserve Component (RC) Training. The training for the RCs is the same as for the Active Component. Training for the RCs will be structured to accommodate the present training system.

(f) Nonresident Training. The Army envisions only minimal impact on nonresident training. If required, a full range of Army Correspondence Course Program and Training Extension Course publications will be prepared to support unit individual and collective training.

(g) The training developed for the HMT will be based on performance requirements obtained through analysis of data generated by logistics support analysis. Training products will be designed according to a Systems Approach to Training (TRADOC Reg 350-7).

8. STANDARDIZATION AND INTEROPERABILITY. The HMT takes advantage of parts commonality with the current HMMWV fleet fielded with Army and Air Force units. The U.S. Air Force recently procured a high mobility trailer for use in their explosive ordnance disposal units. The U.S. Marine Corps is interested in the heavy variant HMMWV and see the HMT adding to that system capability. Coordination and cooperation will be maintained to share information and technical data.

9. FUNDING IMPLICATIONS. (Constant FY89 dollars)

a. Total Research, Development, Test, and Evaluation Cost	#	500K - 3M
b. Total Procurement Cost	#	200M - 300M
c. Unit Cost	#	5K - 10K
d. Total Life Cycle Cost	#	350M - 500M

Based on 30,000 units.

ANNEX A

OPERATIONAL MODE SUMMARY/MISSION PROFILE

1. Operational Mode Summary.

TABLE 1-1 ENVIRONMENTAL CONDITIONS (PEACETIME AND WARTIME)

<u>Climatic Design Types</u>		<u>% Fleet</u>
	Hot	15
	Basic	80
	Cold	5
Europe 5 Scenario		
<u>Movement Terrain</u>	<u>% of Time</u>	<u>Avg MPH</u>
Primary Road	30.0	50
Secondary	30.0	25
Cross-country	40.0	15

2. Mission Profile.

TABLE 1-2 24-HOUR MISSION PROFILE

<u>Mission Functions</u>	<u>Attack (Dynamic)</u>	<u>Defense (Static)</u>	<u>Delay</u>	<u>*Annual Usage</u>	<u>Weighted Average</u>
Number Missions	2	.75	.5	205	1.025
Mobility	70 Mi	30 Mi	60 Mi	8900 Mi	44.5 Mi
Expected %	25%	60%	15%	100%	

TABLE 1-3 24-HOUR MISSION PROFILE, PEACETIME CONDITIONS

<u>Mission Functions</u>	<u>Wargames (Dynamic)</u>	<u>Garrison (Static)</u>	<u>Delay</u>	<u>*Annual Usage</u>	<u>Weighted Average</u>
Number Missions	.75	.25	.25	33.75	.38
Mobility	20 Mi	10 Mi	5 Mi	1080 Mi	12 Mi
Expected %	25%	65%	10%	100%	

*Estimated Annual Usage: 200 days per year wartime operation, and 90 days per year peacetime operation.

(A-1)

ANNEX B

RATIONALE

The following rationale statements correspond to subparagraphs of paragraph 4, Operational Characteristics, and paragraph 7, System Constraints.

The HMT must:

4a. Be capable of being towed by the HMMWV IAW the operational mode summary/mission profile (OMS/MP).

Rationale. The HMT will increase the mobility of HMMWV equipped units that are currently using the M101 series trailer in this role. The lack of mobility of the M101 series trailer poses a rollover hazard when pulled behind a HMMWV. The HMT will solve this safety deficiency. In addition, the HMT may have an increased payload over the current 3/4 ton trailer. The increased payload could result in a reduction of support vehicles currently used to carry mission essential equipment such as generators.

4b. Have a payload of 1,500-2,500 pounds and not exceed the towed load allowance (3,400-lbs) for the Group I/II (M998/M1037) variants. A desired characteristic is that the trailer will meet the towed load allowance (4,200-lbs) of the Group III (Heavy HMMWV) variant.

Rationale. The preponderance of truck/trailer systems will use the Group I/II vehicles as the prime mover. Not exceeding the towed load allowance of these vehicles will preclude vehicular overloads that degrade mobility and cause safety hazards. A fewer number of users need the added towing capacity of the Heavy Variant HMMWV. The 4,200-lb towing capacity of the Group III variants will be useful in towing power generation equipment.

4c. The mobility characteristics of the HMMWV must not be degraded by more than $\leq 10-20\%$ when coupled to the HMT at GVW.

Rationale. Mobility degradation of not more than $\leq 10-20\%$ will retain the cross country mobility of the HMMWV.

4d. Operate worldwide in hot, basic, and cold climatic conditions as outlined in AR 70-38 and conditions of rain, fog, haze, snow, and dust.

Rationale. The HMT and HMMWV are a system and must travel over the same conditions and operate in the same weather.

4e. Have a suspension system that provides ride dynamics comparable to the HMMWV.

(B-1)

Rationale. Comparable ride dynamics between the truck and the trailer will enhance mobility over the current 3/4 ton trailer which tends to oscillate behind the HMMWV. The oscillation and bouncing of the trailer causes severe damage to power generation equipment mounted in the trailer.

4f. Be capable of fording operations equal to that of the prime mover and be equipped with a drainage plug if needed.

Rationale. The truck and trailer travel as a system. The fording capability of the HMMWV without fording kit is 30 inches and 60 inches with the kit. The trailer is expected to follow the HMMWV within this profile. A drainage plug will allow for quick drainage of water due to trailer immersion.

4g. Be equipped with service or surge brakes and an independent, manually operated parking brake.

Rationale. The service or surge brake system will allow for safe stopping of the trailer under all road conditions and loading combinations IAW the OMS/MP. Additionally, a manually operated parking brake is needed to hold the trailer on level ground when not coupled to the HMMWV.

4h. Have a pedestal/retractable leg in the tongue so that the trailer, at GVW, can be stowed on the level.

Rationale. The pedestal/retractable leg is required to allow safe and level storage of trailer while uncoupled from the HMMWV.

4i. Have recessed, internal cargo tiedowns.

Rationale. Recessed tiedowns allow for the full use of the cargo compartment. Cross-country operations require cargo restraint.

4j. Be equipped with kit to protect the cargo.

Rationale. Cargo protection will prevent cargo from being damaged by the elements and provide security.

4k. Be equipped with a removable tail gate.

Rationale. A removable tailgate will facilitate cargo loading and unloading. In addition, during travel over rough terrain, the tailgate will act as an additional cargo restraint if the tiedowns brake.

4l. Be equipped with stabilizer legs, emplaced by the vehicle operator, for stowing on uneven ground.

(B-2)

Rationale. Stabilizer legs allow the vehicle operator to stow and stabilize the trailer on uneven ground when it is not coupled to the HMMWV. Systems such as communications shelters and generators require level stowage for operations on uneven ground.

7a. Transportability. The HMT, at GVW, must be internally air transportable with prime mover by C-130 and larger aircraft. The HMT, at GVW, must be transportable without restriction by highway, rail, and marine modes. The trailer must have military standard lifting and tiedown provisions. The HMT, at GVW, must be externally air transportable by UH-60A,L,M models as a single load and CH-47D and CH-53 with the prime mover. The HMT must be capable of low altitude parachute extraction (LAPE) and low velocity airdrop (LVAD) both as a single load and with the prime mover.

Rationale. All vehicles must adhere to NATO Standard Agreements regarding highway legal load limits. These load limits are also enforced in the Continental U.S. Military standard lifting and tiedown provisions are essential to allow shipment of the HMT by rail, sea, and air. Rail transport reduces wear and tear on tactical vehicles, minimizes en route support, and reduces maintenance requirements. Transport by marine mode is required for logistics over the shore operations. The HMT with the HMMWV must be capable of intra/intertheater transport by aircraft for rapid deployment. External helicopter transport provides operational flexibility when it is not feasible to transport by tactical aircraft. Simultaneous external transport of the truck and trailer as a system by the CH-47D and CH-53 provide rapid employment of the system and more efficient use of transport assets. Joint operations may require lift of the HMT by the CH-53. LAPE and LVAD capability provide alternate insertion methods and is consistent with the like capability of the HMMWV. LAPE and LVAD of the HMMWV and HMT as a system reduces insertion time and more efficiently uses transport assets.

7b. NBC Survivability. The HMT must be NBC contamination/decontamination survivable.

Rationale. In order to reduce degradation of the HMMWV/HMT system due to NBC contamination, the HMT must be survivable in this environment.

7c. Logistics. The HMT will be supported by the standard Army logistics system. No special tools or test equipment will be required and parts and fittings must be compatible with Group I/II HMMWVs. The HMT electrical system must be compatible with the HMMWV and have Army secure lighting. Routine maintenance procedures will be accomplished at organizational level. Maximum allowable time for individual component replacement at organizational level will not exceed 1 hour.

(B-3)

Rationale. In order to reduce the burden on the logistics system, commonality of tools and parts with the HMMWV is essential. Reduction in tools and parts reduces the weight carried in the vehicle. Army secure lighting ensures safe operation of the trailer during convoy operations under blackout conditions. Accomplishing routine maintenance tasks at organizational level in less than 1 hour increases operational readiness.

7d. Mobility. The HMT must have the same tracking width as the HMMWV.

Rationale. The same track will reduce tipping and the rough ride from trailer oscillation between the tracks of a HMMWV of a different width. Track width becomes important during movement through snow, mud, and soft sand. If the trailer does not track with the prime mover, snowplowing occurs and decreases the mobility of the system.

7e(1). Manpower and Personnel. No additional MOS or manpower requirements are authorized with HMT fielding. Organizational level maintenance will be accomplished by system operators (CMFs 11, 13, 16, 19, 54, 63, 76, 91, 93, and 95). Maintenance at DS/GS level will be accomplished by soldiers in CMF 63. No additional skills or knowledge will be required to operate or support the HMT in the field.

Rationale. The trailer will replace the M101 series trailers in HMMWV equipped units that are currently authorized them. Due to this, the fielding of the HMT will not require additional manpower. Organizational maintenance is currently being performed by soldiers in the MOSs that now use the HMMWV/M101 system. No additional skills or knowledge will be required due to the simplicity of the trailer.

7e(2). Human Factors Engineering. The HMT will meet applicable industry and government HFE requirements. The soldier machine interface for the system shall facilitate safe and effective operation and maintenance for the representative Army soldier in CMFs 11, 13, 16, 19, 54, 63, 76, 91, 93, and 95 while wearing the full range of Army protective garments (including arctic and MOPP IV). The HMMWV operator must be able to see the trailer in the sideview mirrors

Rationale. Safe and effective operation enhances operational readiness of both the system and the soldier. The HMMWV and HMT system is subject to use in a wide variety of weather and tactical conditions. Operation and maintenance while wearing the full range of Army protective garments is essential. Visibility of the trailer in the sideview mirrors enhances the drivers ability to back the trailer and reduces the chance of vehicle damage.

7e(3). System Safety/Health Hazard Assessment. The HMT will overcome the safety concern of overloading the HMMWV and the narrow tracking that causes oscillation and turnover of the M101 series trailers behind the HMMWV. The HMT will not pose a safety or health hazard to operating personnel.

Rationale. Eliminating the instability of the current trailer behind the HMMWV is essential both from a safety and operational standpoint. Additional safety problems must not be introduced by the fielding of the HMT.

7e(4)(a). Training Concept. The introduction of the HMT into the Army may require changes to the instructional presentation for New Equipment, Non-Resident, Unit, and Institutional Training. The concept of this training will be based upon providing operator, maintainer, and support personnel skills necessary for effective employment of the HMT on the battlefield. The HMT will not require embedded training or training devices.

Rationale. The training concept will focus on the employment of the HMMWV and trailer as a system. No embedded training or training devices are needed due to the simplicity of the HMT.

7e(4)(b). New Equipment Training (NET). The HMT will require no NET. The transfer of existing skills and knowledge will support operational and maintenance tasks.

Rationale. NET teams will not be needed as the training for the current 3/4 ton trailer is adequate to prepare operators for the use of the system.

7e(4)(c). Institutional Training. The introduction of the HMT will have minimal impact on institutional training. Training on the HMT will be integrated into existing courses.

Rationale. Existing courses teach the use of the 3/4 ton trailer. The existing training will change very little in order to incorporate the HMT into the instruction.

7e(4)(d). Unit Training. The Army envisions only minimal impact on unit training. The transfer of skills and knowledge will support operational and maintenance tasks.

Rationale. Operators currently using the 3/4 ton trailer will transfer their existing skills and knowledge to use with the HMT.

(B-5)

7e(4)(e). Reserve Component (RC) Training. The training for the RC is the same as for the Active Component. Training for the RC will be structured to accommodate the present training system.

Rationale. The RC must train as their active duty counterparts. The training can be incorporated into the existing training program.

7e(4)(f). Nonresident Training. The Army envisions only minimal impact on nonresident training. If required, a full range of Army Correspondence Course Program (ACCP) and Training Extension Course (TEC) publications will be prepared to support unit individual and collective training.

Rationale. It is not anticipated that nonresident training will be affected to a large degree. ACCP and TEC publications will enhance operator training.

7e(4)(g). The training developed for the HMT will be based on performance requirements obtained through analysis of data generated by logistics support analysis. Training products will be designed according to a Systems Approach to Training (TRADOC Reg 350-7).

Rationale. The analysis of performance requirements data will enhance operator training at all levels of instruction.

ANNEX C

COORDINATION

1. The First Draft O&O Plan for the High Mobility Trailer (HMT) was distributed for worldwide staffing on 27 Jan 89. Agencies requested to comment and comments received are listed below:

<u>AGENCY</u>	<u>COMMENTS RECEIVED</u>	<u>COMMENTS ACCEPTED</u>
HQDA		
DAMO-FDL	NO COMMENT	
DALO-SMT	.	
SARD-ZCS	.	
HQ TRADOC	25	25
HQ AMC	6	6
USALOGC	CONCUR	
FORSCOM	NO COMMENT	
WESTCOM	2	2
4TH U.S. ARMY	NO COMMENT	
USAREUR & 7TH ARMY	.	
CHIEF OF NAVAL OPNS	.	
COMDT MARINE CORPS	.	
HQ U.S. AIR FORCE	.	
MTMC-TEA	2	2
SSC	NO COMMENT	
USACAC	9	9
USALEA	5	4
OTEA	4	4
LABCOM	NO COMMENT	
TACOM	14	14
AMSAA	12	12
TECOM	NO COMMENT	
AHS	CONCUR	
AIR DEF SCH	NO COMMENT	
ARMOR SCH	1	1
AV CNTR	5	5
AV LOG SCH	7	7
CHAPLAIN SCH	NO COMMENT	
CHEMICAL SCH	1	1
ENGR SCH	NO COMMENT	
FIELD ARTY SCH	13	13
INFANTRY SCH	1	1
INTEL SCH	NO COMMENT	
JFK SW CNTR & SCH	.	
MIL POLICE SCH	4	4
OMMCS	7	7
QUARTERMASTER SCH	NO COMMENT	
SIGNAL SCH	.	
TRANS SCH	6	6

(C-1)

2. Rationale for comments not accepted:

USALEA:

Comment. Determine maintenance manpower requirements. 11,000 slots were deleted from TOEs when the HMMWV replaced the 1/4 ton with trailer.

Rationale. A perusal of TOEs showed that at most 2000 maintenance slots were deleted from the force structure when the HMMWV was fielded. Of the original HMMWV BOIPs, 5 remain which authorize the M101 as an ASIOE. However, there has been no increase in authorized maintenance manpower associated with these ASIOEs. Therefore, the replacement of the M101 on a one-for-one basis will not require any additional manpower.

(C-2)

APPENDIX B

BRAKING MODEL

Appendix B
BRAKING MODEL

This appendix contains a 4 page long print out of the model, a Lotus 123 spreadsheet. The following user dependent variables were used to generate the data in the shown spreadsheet:

Desired Coefficient of Tire/Surface Friction = 0.78
Initial Velocity = 20 MPH
Slope angle = 13 deg (23%)
Brake Peddle Force = 350 Lbs
Surge Brake is Active
Vehicle is Traveling Down Hill
Vehicle is Traveling Forward

Weight configuration used:

Trailer GW = 3465 Lbs
HMMWV GW = 8408 Lbs

These parameters are identical to test 5 of the Operational Model Validation Test found in Appendix B. The results section shows that the HMMWV's wheels were not locked up and the braking distance is 27.95 feet. This, incidently is 1.7% off from the tested value.

This report includes a 5.25" floppy disk, found on the rear cover, that contains a copy of the braking model. If this copy has been removed or damaged one may be obtained by sending a self addressed, postage paid envelope (large enough to fit a 5.25" floppy disk) requesting the High Mobility Multipurpose Wheeled Vehicle/High Mobility Trailer Brake Model to:

U.S. Army Tank-Automotive Command
ATTN: Technical Library
Warren, MI 48397-5000

The disk contains a copy of the model labeled Brake.wk1. The user must have a copy of Lotus 123 version 2 on his/her computer to use the model. It is recommended that the user copy Brake.wk1 into the Lotus 123 directory of the user's hard drive. The disk can than be kept as a backup in case the model is accidently altered.

After copying the file Brake.wk1 into your hard drives Lotus 123 directory, run Lotus 123. Once the empty Lotus spreadsheet appears on the screen press the "/" key. This brings up the lotus command menu. Move the highlighter over to the File option, with the arrow keys, and press [RETURN]. Move to the Retrieve option and press [RETURN]. Lotus will than show all of the ".wk1" files that are on your c: drive. Place the highlighter on Brake and press [RETURN] to select. If it tries to list the files on the a: drive, and the drive is empty, it will sound an error. The easiest way to get around this is to place a

Appendix B
(continued)

formatted disk in drive a: press [ESCAPE] and repeat the file retrieve steps. It will now try to find a file on drive a:, whether it does or not is incidental, just press the [ESCAPE] and type c:, press [RETURN]. It should look at the c: drive. You can now select the Brake.wk1 file. Once the model appears it is ready to be used.

Use the arrows keys to move around the spreadsheet. Move to the User Dependent Variables section near the top. Vary the variables and press the Alternate and "A" key simultaneously to invoke the macro. The computer will scan the Coefficient of Friction column until it finds your specified value. It will then read the corresponding values for lockup and braking distance. The computer copies these values to the Results section at the top and positions the highlighter for the user to view this section.

NOTE: Because the variables of the spreadsheet must be allowed to vary, the individual cells are not protected. This means that the user can very easily alter a cell, perhaps changing a very complicated formula. For example, you have placed the highlighter on a formula containing cell. Now you want to move, so you reach for the arrow keys but inadvertently press the "\" key and then the arrow key. Looking back the cell you just left will now contain a "\". The solution is just to retrieve the file Brake.wk1 again without saving.

HIGH MOBILITY MULTI-PURPOSE WHEELED VEHICLE AND HIGH MOBILITY TRAILER BRAKING MODEL

*****ANALYSIS WITH INCREASING COEFFICIENT OF TIRE/ROAD ADHESION*****

*****USER DEPENDENT VARIABLES*****

 DESIRED COEFF. TIRE/SURFACE FRICTION= 0.78
 CONSTANT INTL. VELOCITY= 20.00 [MPH]
 SLOPE = 13.00 [DEG] 0.2269 [RAD] 23.09 [%]
 BRAKE PEDDLE FORCE= 350.00 [LBS]
 IS THE SURGE BRAKE ACTIVE ? 1.00 YES-1,NO-0
 TRAVELING UP OR DOWN HILL ? 0.00 UP-1,DWN-0
 TRAVELING IN REVERSE ? 0.00 YES-1,NO-0

*****RESULTS*****

WHEEL LOCKUP OCCURED 0.00 YES-1,NO-0
 BRAKING DISTANCE= 27.95 [FT]

NON-DEPENDENT VARIABLES

TRAILER WEIGHT= 3465.00 [LBS]
 HMMWV (M998) WEIGHT= 8408.00 [LBS]
 FRT AXLE= 3521.00 [LBS]
 RR AXLE= 4887.00 [LBS]
 EFFECTIVE AREA/BRAKE PAD= 8.70 [IN^2]
 GEAR RATIO= 1.92
 EFF. RADIUS HMMWV ROTOR= 4.10 [IN]
 EFF. RADIUS TRAILER ROTOR= 6.00 [IN]
 CALIPER PISTON DIAMETER= 2.60 [IN]
 HMMWV PAD COEFFICIENT= 0.46
 TRAILER PAD COEFFICIENT= 0.30
 TIRE DIAMETER= 36.00 [IN]
 GRAVITATIONAL CONSTANT= 32.20 [FT/S^2]

WEIGHT DEPENDENT VARIABLES

MULTIPLICATION FACTOR= -1.00
 TOTAL MASS= 368.73 [SLUGS]
 HMMWV MASS= 261.12 [SLUGS]
 TRAILER MASS= 107.61 [SLUGS]
 TOTAL WEIGHT= 11873.00 [LBS]
 K= 0.71

WEIGHT AND GRADE DEPENDENT VARIABLES

TRAILER NORMAL FORCE= 3376.19 [LBS]
 TRAILER PULL FORCE= 779.46 [LBS]
 HMMWV NORMAL FORCE:
 FRT AXLE= 3430.76 [LBS]

RR AXLE= 4761.75 [LBS]
HMMWV PULL FORCE= 1891.39 [LBS]
TOTAL PULLING FORCE RQD= 2670.84 [LBS]
HMMWV TRACTION CONSTANT= 147465.06 [LBS*IN] 12288.76 [FT*LBS]

BRAKING VARIABLES

BRAKE PRESSURE= 2058.82 [PSI]
BRAKING FORCE:
FRT WHEELS= 10056.42 [LBS]
RR WHEELS= 2715.23 [LBS]
HMMWV BRAKING TORQUE= 100538.48 [IN*LBS] 8378.21 [FT*LBS]
PHI, NEGATIVE POTENTIAL= 37.40 [RAD]
PHI POSITIVE POTENTIAL= 18.86 [RAD]
APPLICABLE PHI= 37.40 [RAD]
ENERGY DISTANCE= 29.22 [FT]

COEFFICIENT OF ROAD/SURFACE FRICTION DEPENDENT VARIABLES

	COEFFICIENT TIRE/SURFACE FRICTION	LOCKUP PREDICTION 0-NO,1-YES	HMMWV DECELERATION [FT/S^2]	POSSIBLE TRAILER BRAKING FORCE [LBS]	APPLICABLE TRAILER BRAKING FORCE [LBS]	TRAILER DECELERATION [FT/S^2]	BRAKING DISTANCE [FT]	COEFFICIENT TIRE/SURFACE FRICTION
ICE	0.00	1.00	-6.96	0.00	0.00	0.00	-61.80	0.00
	0.01	1.00	-6.75	-1.45	-1.45	-0.01	-63.63	0.01
	0.02	1.00	-6.54	-2.81	-2.31	-0.03	-65.58	0.02
SNOW	0.03	1.00	-6.32	-4.08	-1.08	-0.04	-67.66	0.03
	0.04	1.00	-6.11	-5.26	-5.26	-0.05	-69.88	0.04
	0.05	1.00	-5.90	-6.35	-6.35	-0.06	-72.27	0.05
	0.06	1.00	-5.68	-7.34	-7.34	-0.07	-74.84	0.06
	0.07	1.00	-5.47	-8.24	-8.24	-0.08	-77.61	0.07
	0.08	1.00	-5.26	-9.05	-9.05	-0.08	-80.61	0.08
	0.09	1.00	-5.04	-9.77	-9.77	-0.09	-83.86	0.09
	0.10	1.00	-4.83	-10.39	-10.39	-0.10	-87.39	0.10
	0.11	1.00	-4.61	-10.93	-10.93	-0.10	-91.26	0.11
	0.12	1.00	-4.40	-11.37	-11.37	-0.11	-95.50	0.12
	0.13	1.00	-4.19	-11.72	-11.72	-0.11	-100.18	0.13
	0.14	1.00	-3.97	-11.97	-11.97	-0.11	-105.36	0.14
	0.15	1.00	-3.76	-12.14	-12.14	-0.11	-111.13	0.15
	0.16	1.00	-3.55	-12.21	-12.21	-0.11	-117.60	0.16
	0.17	1.00	-3.33	-12.19	-12.19	-0.11	-124.89	0.17
	0.18	1.00	-3.12	-12.08	-12.08	-0.11	-133.19	0.18
	0.19	1.00	-2.91	-11.88	-11.88	-0.11	-142.71	0.19
HARD PACKED	0.20	1.00	-2.69	-11.59	-11.59	-0.11	-153.73	0.20
	0.21	1.00	-2.48	-11.20	-11.20	-0.10	-166.67	0.21
	0.22	1.00	-2.26	-10.72	-10.72	-0.10	-182.04	0.22
	0.23	1.00	-2.05	-10.15	-10.15	-0.09	-200.61	0.23
	0.24	1.00	-1.84	-9.49	-9.49	-0.09	-223.51	0.24

	0.25	1.00	-1.62	-8.74	-8.74	-0.08	-252.43	0.25
	0.26	1.00	-1.41	-7.89	-7.89	-0.07	-290.12	0.26
	0.27	1.00	-1.20	-6.95	-6.95	-0.06	-341.27	0.27
	0.28	1.00	-0.98	-5.92	-5.92	-0.06	-414.66	0.28
	0.29	1.00	-0.77	-4.80	-4.80	-0.04	-528.80	0.29
	0.30	1.00	-0.56	-3.59	-3.59	-0.03	-730.72	0.30
	0.31	1.00	-0.34	-2.28	-2.28	-0.02	-1184.89	0.31
	0.32	1.00	-0.13	-0.88	-0.88	-0.01	-3150.24	0.32
	0.33	1.00	0.09	0.61	0.61	0.01	4737.60	0.33
	0.34	1.00	0.30	2.19	2.19	0.02	1348.48	0.34
	0.35	1.00	0.51	3.86	3.86	0.04	784.89	0.35
	0.36	1.00	0.73	5.63	5.63	0.05	552.94	0.36
	0.37	1.00	0.94	7.48	7.48	0.07	426.44	0.37
	0.38	1.00	1.15	9.43	9.43	0.09	346.81	0.38
	0.39	1.00	1.37	11.47	11.47	0.11	292.07	0.39
	0.40	1.00	1.58	13.61	13.61	0.13	252.13	0.40
	0.41	1.00	1.79	15.83	15.83	0.15	221.70	0.41
	0.42	1.00	2.01	18.15	18.15	0.17	197.74	0.42
	0.43	1.00	2.22	20.56	20.56	0.19	178.40	0.43
	0.44	1.00	2.44	23.06	23.06	0.21	162.45	0.44
	0.45	1.00	2.65	25.65	25.65	0.24	149.07	0.45
	0.46	1.00	2.86	28.34	28.34	0.26	137.70	0.46
	0.47	1.00	3.08	31.12	31.12	0.29	127.90	0.47
	0.48	1.00	3.29	33.99	33.99	0.32	119.37	0.48
	0.49	1.00	3.50	36.95	36.95	0.34	111.89	0.49
	0.50	1.00	3.72	40.00	40.00	0.37	105.27	0.50
	0.51	1.00	3.93	43.14	43.14	0.40	99.37	0.51
	0.52	1.00	4.14	46.38	46.38	0.43	94.07	0.52
	0.53	1.00	4.36	49.71	49.71	0.46	89.30	0.53
	0.54	1.00	4.57	53.13	53.13	0.49	84.97	0.54
EARTHEN ROAD	0.55	1.00	4.79	56.64	56.64	0.53	81.03	0.55
WET	0.56	1.00	5.00	60.25	60.25	0.56	77.43	0.56
	0.57	1.00	5.21	63.94	63.94	0.59	74.12	0.57
	0.58	1.00	5.43	67.73	67.73	0.63	71.08	0.58
	0.59	1.00	5.64	71.61	71.61	0.67	68.26	0.59
GRAVEL	0.60	1.00	5.85	75.59	75.59	0.70	65.65	0.60
	0.61	1.00	6.07	79.65	79.65	0.74	63.23	0.61
	0.62	1.00	6.28	83.81	83.81	0.78	60.97	0.62
	0.63	1.00	6.49	88.06	88.06	0.82	58.86	0.63
	0.64	1.00	6.71	92.40	92.40	0.86	56.88	0.64
	0.65	1.00	6.92	96.83	96.83	0.90	55.03	0.65
	0.66	1.00	7.14	101.35	101.35	0.94	53.29	0.66
	0.67	1.00	7.35	105.97	105.97	0.98	51.65	0.67
EARTHEN ROAD	0.68	1.00	7.56	110.68	110.68	1.03	50.10	0.68
DRY	0.69	0.00	14.73	218.73	218.73	0.59	28.09	0.69
	0.70	0.00	14.73	221.90	221.90	0.60	28.08	0.70
	0.71	0.00	14.73	225.07	225.07	0.61	28.06	0.71
	0.72	0.00	14.73	228.24	228.24	0.62	28.04	0.72
	0.73	0.00	14.73	231.41	231.41	0.63	28.03	0.73
	0.74	0.00	14.73	234.58	234.58	0.64	28.01	0.74

ASPHALT	0.75	0.00	14.73	237.75	237.75	0.64	28.00	0.75
	0.76	0.00	14.73	240.92	240.92	0.65	27.98	0.76
	0.77	0.00	14.73	244.09	244.09	0.66	27.97	0.77
	0.78	0.00	14.73	247.26	247.26	0.67	27.95	0.78
	0.79	0.00	14.73	250.43	250.43	0.68	27.93	0.79
CONCRETE WET	0.80	0.00	14.73	253.60	253.60	0.69	27.92	0.80
CONCRETE DRY	0.81	0.00	14.73	256.77	256.77	0.70	27.90	0.81
	0.82	0.00	14.73	259.94	259.94	0.70	27.89	0.82
	0.83	0.00	14.73	263.11	263.11	0.71	27.87	0.83
	0.84	0.00	14.73	266.28	266.28	0.72	27.86	0.84
	0.85	0.00	14.73	269.45	269.45	0.73	27.84	0.85
	0.86	0.00	14.73	272.62	272.62	0.74	27.83	0.86
	0.87	0.00	14.73	275.79	275.79	0.75	27.81	0.87
	0.88	0.00	14.73	278.96	278.96	0.76	27.79	0.88
	0.89	0.00	14.73	282.13	282.13	0.77	27.78	0.89
	0.90	0.00	14.73	285.30	285.30	0.77	27.76	0.90
	0.91	0.00	14.73	288.47	288.47	0.78	27.75	0.91
	0.92	0.00	14.73	291.64	291.64	0.79	27.73	0.92
	0.93	0.00	14.73	294.81	294.81	0.80	27.72	0.93
	0.94	0.00	14.73	297.98	297.98	0.81	27.70	0.94
	0.95	0.00	14.73	301.15	301.15	0.82	27.69	0.95
	0.96	0.00	14.73	304.32	304.32	0.83	27.67	0.96
	0.97	0.00	14.73	307.49	307.49	0.83	27.66	0.97
	0.98	0.00	14.73	310.66	310.66	0.84	27.64	0.98
	0.99	0.00	14.73	313.83	313.83	0.85	27.63	0.99
	1.00	0.00	14.73	317.00	317.00	0.86	27.61	1.00
	NA	0.00	NA	ERR	ERR	ERR	NA	NA

APPENDIX C

OPERATIONAL MODEL VALIDATION TEST
GENERAL MOTORS PROVING GROUNDS
MILFORD, MICHIGAN

Appendix C
OPERATIONAL MODEL VALIDATION TEST

INTRODUCTION

The Emerging Systems Division (AMSTA-ZD) supported by the Testing Support Division (AMSTA-TB) at TACOM performed a braking test using a M1036 High Mobility Multipurpose Wheeled Vehicle (HMMWV) and the XM1071 Desert Mobility Vehicle System Test Bed Trailer. The XM1071 trailer was designed and built in house at the U.S. Army Tank-Automotive Command (TACOM) to be a test demonstration vehicle for the DMVS. The trailer was designed to specifications very similar to those required for the HMT. Its track width and wheel assembly is identical to that of the HMMWV. The trailer is equipped with a surge brake and has a curb weight of 1286 pounds. The test was conducted, under contract DAAE07-90-P-R008 with General Motors. The test was performed on 6 June 1990 at General Motor's Proving Grounds (GMPG) Milford, Michigan. The test was designed to validate the model and consisted of two parts a flat and 23% grade brake test. A brake bias test was also performed on the HMMWV. This test is performed using a Roll Transducer Pad (RPT). The RPT test measures the braking contribution of each tire on a braking vehicle.

TEST INSTRUMENTATION

Data was collected utilizing the following instrumentation:

1. Fifth Wheel (ref. Figure C-1) - Provides the velocity of the vehicle. Mounted to the driver side passenger door. [± 0.5 MPH]
2. Brake Peddle Load Transducer - Mounted to the brake peddle, provides the force applied by the vehicle's operator to the brake peddle. [± 5 Lbs]
3. Load Cell - Mounted between the trailer and the HMMWV, measures the tensile force generated during the coefficient of tire/surface friction test. It also provided tensile/compression forces incurred during the brake test. [± 20 Lbs]
4. Strip Chart - Records output, with time, from the instruments. Placed inside the HMMWV.

The HMMWV and trailer were loaded to their gross vehicle weights 8048 and 3465 pounds, respectively.

TEST PROCEDURE

Nine brake tests were performed, four on the flat grade and five on the 23% grade. Prior to the brake tests a test for the coefficient of tire/surface friction was performed.

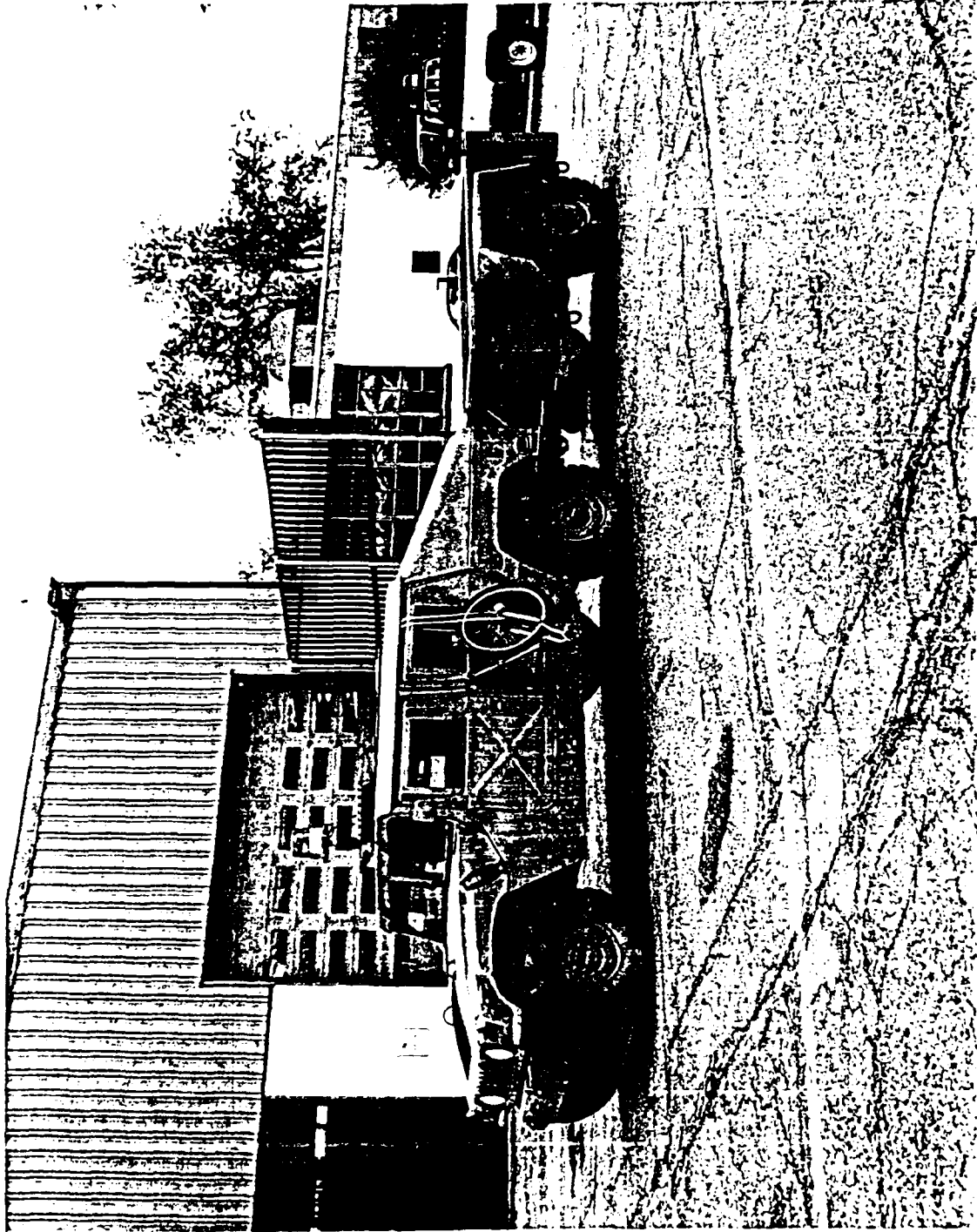

Figure C-1
M1036 HMMWV / XM1071 Trailer

Coefficient of Friction Test

Prior to running the brake test on the flat and 23% grade surfaces a test for the coefficient of friction between the tires and the road was performed. This was accomplished using the trailer. The procedure consisted simply of locking the trailer's brakes than pulling the trailer with the HMMWV, scaping the tires along the surface while measuring the induced force with the load cell. Knowing the trailers weight (W_t) and the force required to pull it (F), the coefficient of tire/surface friction (μ) is derived with the following relation:

$$\mu = \frac{F}{W_t}$$

The flat grade surface was asphalt. Two trials determined a mean friction coefficient of 0.74. The 23% grade surface was concrete and from two trials the coefficient of friction was found to be 0.78.

Flat Grade Braking Test

The flat grade was a 1.5 mile streight asphalt road. The HMMWV with the HMT in tow was positioned at one end of the road. With the trailer's surge brake activated the operator traveling down the road brought the vehicle to approximately 20 MPH. At a designated position on the road the operator applied the brakes as hard as he could. The vehicle grinded to a halt but, interestingly the wheels did not lock up as anticipated. The test was than repeated with the operator achieving a speed of 40 MPH. The surge brake on the trailer was than disconnected and the 20 and 40 MPH brake tests were performed.

23% Grade Brake Test

The 23% grade was approximately a 500 ft. long concrete road. With the surge brake operating the HMMWV/XM1071 was positioned near the top of the slope. Releasing the brake the operator allowed the vehicle to coast to a designated position where he applied the brake as hard as he could. Two trials were run with the surge brake operating and two with the surge brake inoperable.

Brake Bias Test

The Roll Transducer Pad (RTP) at GMPG is located in its own building in the middle of GM's test tracks. The RTP building is a garage like structure with a road running straight through it. A control room is positioned on the side of the road, housing the computers which dicipher and compile data received from the RTP. The Roll Transducer Pads are located in the road in the building. The pads measure the shearing force felt at each tire of a braking vehicle as it travels across the surface of the pads. Prior to running the test, the vehicle is placed on the pads to measure the weight on each of the

vehicles tires. After the weight and length of the vehicle are entered, the computer calculates the center of gravity of the vehicle. The RTP test procedure is as follows; the vehicle, positioned down the road, travels towards the building. Just before entering the building the operator applies the brakes. As the vehicle crosses over the pads the computer in the control room documents the shearing force (fore/aft force) created by the brakes at each tire. Also, measured is the deceleration rate of the vehicle, the vertical and lateral force at each tire. Four iterations of this test were performed achieving deceleration rates of 0.24, 0.28, 0.4, and 0.49 g's. While running each test the brake peddle load transducer was functioning, recording the force applied to the brake peddle by the operator. Data printed by the RTP computer is found in Appendix I.

The model requires a caliper pressure to be entered. Because an instrument capable of reading the caliper pressure was not available for this test. The data from the RTP test was utilized to determine a relation between the brake peddle force and the caliper pressure. The RTP test provides the fore/aft force felt at each tire. The model predicts the fore/aft force generated by the brakes on the front and rear tires. Therefore by inputing pressures into the model iteritively until the force at the tires in the model matches the force read by the RTP, this pressure is than noted. This process was repeated for each of the four RPT tests. Knowing the brake peddle force for each of the RPT tests and now the caliper pressures as predicted by the model a average ratio between brake peddle force and caliper pressure was calculated to be 5.9.

RESULTS

Data collected from the flat and 23% grade brake tests along with the model's calculated braking distance is compiled in Table C-1. As shown the overall mean percent difference between the experimental and model predicted braking distances is 10% excluding the highest and lowest percent differences (57% and 0%). A percent difference of 10% is considered by modeling experts to be good.

The model is very accurate when predicting distances where the tires are locked up, as shown by test 4 which had tire lockup and a percent difference of 1.5%. On the other hand it appears the model has difficulty predicting distances when the brake peddle force is low, as demonstrated by test 8 with a brake peddle force of 290 pounds and a percent difference of 57.

Probable Sources of Error

- Coefficients of friction are difficult to predict. When measuring a surface the coefficient found in one area might not be the same as that of another area. The coefficients determined for asphalt and concrete during the operational test 0.74 and 0.78, respectively are according to research quite low. Asphalt and concrete normally range between 0.8-0.9. This however has a minimal effect on braking distances where the brakes are not locked up. The coefficient of friction is further complicated when

TABLE C-1
VALIDATION BRAKE TEST AND MODEL DATA COMPARISON

TEST	INITIAL VELOCITY MPH	BRAKE TIME sec	CALCULATED DECELERATION ft/s ²	PEDDLE PRESSURE PSI	MAXIMUM LOAD LBS	THEORETICAL BRAKING DISTANCE ft	EXPERIMENTAL BRAKING DISTANCE ft	PERCENT DIFFERENCE
FLAT GRADE $\mu = 0.74$								
1 (SURGE)	20	1.4	22.3	320	6000	20.5	21.8	6.0
2 (SURGE)	40	2.8	21.0	362	4750	72.7	82.2	12.0
3	20	1.7	17.8	350	6375	27.6	24.2	14.0
4	42	3.7	16.8	430	6750	117.0 (LOCKED UP)	115.3	1.5
23% GRADE $\mu = 0.78$								
5 (SURGE)	20	1.9	15.1	350	5500	28.0	28.5	1.7
6 (SURGE)	20	2.1	13.8	325	6000	31.2	31.2	0.0*
7	18	2.7	10.3	320	3625	49.7	37.6	33.0
8	19	2.8	10.3	290	4375	66.0	43.0	57.0*
9	21	3	10.4	394	4000	46.4	46.9	1.0
MEAN			15.3	349				10%

* HIGHEST AND LOWEST PERCENT DIFFERENCES WERE EXCLUDED FROM THE CALCULATION OF THE MEAN PERCENT DIFFERENCE.

considering heat. This is very evident with brake pads whose coefficient can vary over a range of 0.35-0.55, according to Kelsey Hayse. Note that an average value of 0.46 is used in the model. This is most likely a major source of error.

- Data collected during the validation test was done so with a strip chart (ref. Figure B-2). The strip chart records output from the test instruments on photo sensitive paper. The lines on the paper are somewhat distorted making measurement difficult.
- The brake peddle forces of the validation test were not constant, but were considered so by taking a rough average.
- As can be seen in Figure C-2, the force felt by the load cell is in the form of a sine wave with a decreasing amplitude. This force due to complicity of derivation was conservatively averaged.

The formentioned are thought to be the primary sources of error and not the only existing error in the model and test. The model is an inexpensive tool for determining the braking distance of a wheeled vehicle and trailer combination. It provides its user an instantaneous way of determining the systems braking limitations in a multitude of situations.

Figure C-2
Sample Data Strip

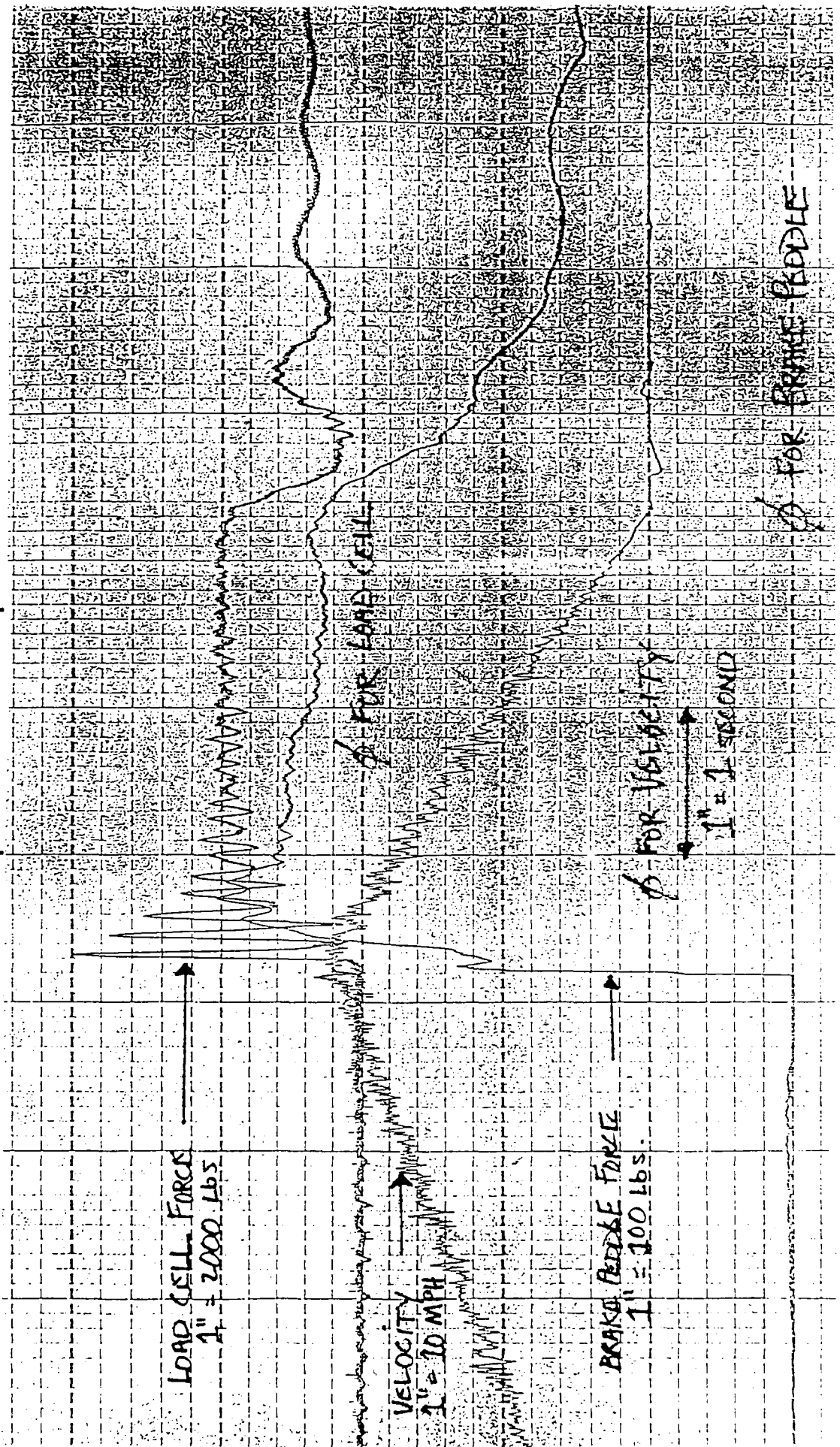

APPENDIX D

MODEL VALIDATION BASED ON TEST DATA
FROM PROTOTYPE QUALIFICATION TEST
YUMA PROVING GROUNDS

Appendix D
MODEL VALIDATION BASED ON TEST DATA FROM PROTOTYPE
QUALIFICATION TEST AT YUMA PROOVING GROUNDS

A brake test was performed at the U.S. Army Yuma Prooving Grounds. The brake test was part of a Prototype Qualification Test on the XM1071 Desert Mobility Vehicle System (DMVS) Trailer¹⁰. For the test the trailer was loaded with a payload of 2000 Lbs, making its GWV 3286 Lbs. A M1038 High Mobility Multipurpose Wheeled Vehicle (HMMWV) was used for this test. The HMMWV was loaded to its GWV of 7700 Lbs.

The service brake test was performed on a dry asphalt surface and in accordance with MIL-T-10579G, paragraph 4.6.2.3 (TOP 2-2-608). The system attained a forward speed of 20 mph, the operator then applied the brake in a panic stop (as hard as he could). The HMMWV's tires were observed to lock-up but the trailer's did not. The system came to a complete stop at 21.91 feet.

This test data was then input into the model in order to test the validity of the model. The following parameters were used:

Initial velocity = 20 mph
Slope angle = 0 deg
Trailer Weight = 3286 Lbs
HMMWV weight = 7700 Lbs (Split evenly on front and rear wheels)
Brake Peddle Force = 430 Lbs

A Brake peddle force of 430 pounds-force is the highest pressure observed during the validation test in Appendix B. This force assures the brakes lock up the tires. Dry asphalt, according to research, has a coefficient of from 0.81-0.85. The following values of braking distances were generated by the model at the indicated coefficients:

<u>Coefficient</u>	<u>Braking Distance</u>
0.81	21.07
0.85	19.94

The percent difference between the test data and model data ranges from 3.8% to 9.0%.

APPENDIX E

MODEL VALIDATION BASED ON TEST DATA
FROM PROTOTYPE QUALIFICATION TEST
ABERDEEN PROVING GROUNDS

Appendix E
 MODEL VALIDATION BASED ON TEST DATA FROM PROTOTYPE
 QUALIFICATION TEST AT ABERDEEN PROOVING GROUNDS

As directed by TACOM the U.S. Army Combat System Test Activity (USACSTA), Aberdeen Prooving Ground (APG), MD, prepared a test plan summary and conducted the Prototype Qualification Test (PQT)¹¹ of the XM1071, Desert Mobility Vehicle System (DMVS) Trailer. Included in this test was a service brake test. The service brake test was performed on a concrete surface with the trailer loaded to a GVW of 3100 pounds and a M988 HMMWV loaded to a GVW of 5559 pounds. The test procedure consisted of the HMMWV/XM1071 attaining a measured speed and than the driver would apply the brakes as hard as he could. The service brake test did not include determination of the coefficient of tire/surface friction therefore, an average value for concrete of .85 was used. The following table sumarizes the test results along with the model predicted distances:

<u>MPH</u>	<u>Distance (Test)</u>	<u>Distance (Model)</u>	<u>% Difference</u>
6.5	4.3	2.30	46.50
12.6	8.5	8.60	1.18
20.0	20.0	21.77	8.85
25.0	33.5	34.00	1.50
30.8	47.9	49.00	2.30
37.2	66.9	75.33	12.60
43.0	92.5	100.65	8.81
49.6	114.5	130.70	14.15
54.0	147.0	158.70	7.96
		Mean	11.5%

APPENDIX F

HIGH MOBILITY TRAILER
DRAFT REQUIRED OPERATIONAL CAPABILITY (ROC)
25 January, 1990

DRAFT
REQUIRED OPERATIONAL CAPABILITY (ROC)

1. TITLE

- a. Descriptive Title: High Mobility Trailer (HMT)
- b. Category: In Process Review (IPR)
- c. CARDS Reference Number:

2. NEED/THREAT.

a. Need. There is a need for a companion trailer for the High Mobility Multipurpose Wheeled Vehicle (HMMWV), which provides improved off-road mobility and increased payload over the present M101 series 3/4 ton trailer. The Commander, 9th Infantry Division documented this need in an Operational Needs Statement (ONS) dated 28 Oct 87. The M101 series trailer lacks stability because its wheels do not have the same tire tread width (i.e., track) as the HMMWV and its suspension does not provide adequate wheel travel or ride dynamics. Thus, in soft soils and rough terrain, the trailer has the propensity to overturn, even at low speeds. The current M101 series trailers do not provide enough payload or cube capacity. A trailer with greater payload capacity will result in fewer instances of overloading the prime mover and its associated trailer. The introduction of the HMT may reduce the number of vehicles and trailers needed to perform unit missions.

b. Threat. The system will not counter any threat. This system and associated personnel are vulnerable to the spectrum of threat destructive capabilities at all levels of conflict from low through high intensity. Man-made and natural obstacles will impede trailer movement. Destructive capability such as direct and indirect fires, missile effects, antipersonnel and antitank mines, and sabotage explosives can damage the system and harm operators. Nuclear/biological/chemical (NBC) warfare operations can render the system temporarily unusable.

3. INITIAL OPERATIONAL CAPABILITY (IOC): 2QFY94.

4. OPERATIONAL AND ORGANIZATIONAL PLAN.

a. The HMT will operate throughout the battlefield to include rear, main battle, and covering force areas. The HMT will deploy under any scenario for which any variant of the HMMWV deploys.

b. The HMT will replace on a one-for-one basis, the M101 series trailer in units currently authorized a 3/4 ton trailer for use with the HMMWV. The HMT will be found in the following organizations: Field Artillery units (SRC 06 series) for firing batteries, fire direction centers, and AN/TPQ-36 and AN/TPQ-37 radar sections; Quartermaster units (SRC 10447LO) for airdrop equipment support units; Medical units (SRC 08 series) for treatment squad supplies and Chemical/Biological Protective Shelters (CBPS) supplies; Chemical units (SRC 03 series) for pumps and hoses for the M17 Lightweight Decontamination System and XM56 Dual Purpose Smoke/Decontamination System; Signal units for generators, antennas, and mast assemblages; Armor (SRC 17 series), Aviation (SRC 01 series), Air Defense (SRC 44 series), and Infantry (SRC 07 series) units for general cargo. Organizational level maintenance will be provided by the unit maintenance personnel now supporting the HMMWV/M101 system.

5. OPERATIONAL CHARACTERISTICS. See Appendix 1.

6. TECHNICAL ASSESSMENT. The operational characteristics in Appendix 1 of this document were used to conduct a technical assessment and a risk analysis. The concept for the HMT was determined to be high risk technically in the areas of dimensions, air transportability, lightweight run flat/no flat tires and mobility. All other characteristics were considered technically feasible.

7. SYSTEM SUPPORT ASSESSMENT. The TACOM acquisition and fielding of the HMT will be supported by the Army Logistics System. The support concept will make maximum use of existing TO&E tools, test, measurement, and diagnostic equipment (TMDE), support equipment and current MOS qualified personnel. Information concerning logistical requirements will be jointly determined and documented by the materiel and combat developers. An Integrated Logistics Support (ILS) Plan will be developed by the ILS management team and updated throughout the acquisition process. The Logistics Support Analysis/Logistics Support Analysis Record (LSA/LSAR) process will determine and define logistics support, personnel tasks and skills required for the operation, maintenance, and support of the system. A System Support Package will be validated prior to IOC. The system will be fielded using the materiel fielding total package/unit materiel fielding concept.

(2)

8. MANPRINT ASSESSMENT.

a. Manpower/Force Structure Assessment. Introduction of the HMT will not create any new or peculiar MOS, nor will it require an increase in operator personnel for the RA, USAR, or ARNG component. It may produce an additional skill identifier (ASI) for operators/maintainers. Current MOS capabilities are adequate and operators will be assigned on an additional duty basis. The final revision of user requirements is in the BOIP/QQPRI. It is envisioned that no additional support personnel are required.

b. Personnel Assessment. The HMT will be operated and maintained during missions (field environment) by soldiers in almost all MOSSs. It will be maintained and repaired in garrison by MOS 63B. The soldier operating and maintaining the HMT will have an aptitude of 90 in Mechanical Maintenance (MM) and the support personnel will range from the 5th to the 95th percentile of soldiers in the US Army. An increase in soldier work load is not expected due to the addition of this new equipment.

c. Training Assessment. The materiel developer and the TRADOC proponent will develop a complete training subsystem specifically designed to support all phases of training (from initial entry through sustainment to new equipment) for user testing and initial fielding.

(1) As a result of the market survey and upon completion of the LSA generated IAW DARCOM Pam 750-16 for system operations and maintenance, the materiel developer and the TRADOC proponent school will jointly evaluate the need for standard technical documentation, training devices, extension training materials and the requirements for NET.

(2) System technical manuals and materials will be IAW AR 310-3. Commercially available technical manuals and materials will be evaluated for adequacy by the TRADOC school IAW Chapter 8, AR 310-3.

(3) The materiel developer will provide any training devices identified as required by subparagraph a above under the authority of this document.

(3)

(4) The TRADOC proponent will develop or ensure development of any training products, or changes to existing ones, required for the HMT. The training products developed as part of the training subsystem will be designed according to the Systems Approach to Training (TRADOC Reg 350-7) using the data generated IAW DARCOM Pam 750-16.

(5) The Training Test Support Package will be evaluated during operational testing.

d. Human Factors Engineering. The soldier/machine interface for this system will facilitate safe and effective operation and maintenance for the full range of Army protective garments used in basic, hot, and cold environments in accordance with military standards.

e. System Safety. The HMT will comply with all applicable Federal Motor Vehicle Safety Standards and Federal Motor Carrier Safety Regulations as specified in appropriate military standards.

f. Health Hazard Assessment. The HMT shall comply with applicable military standards for health requirements to ensure that health hazards are controlled throughout the life cycle of the system.

9. STANDARDIZATION AND INTEROPERABILITY.

a. Currently the Air Force has requested to be kept informed of the progress of the HMT.

b. Currently there are no standardization, interoperability, or commonality constraints that significantly effect or apply to the HMT due to joint service missions, tasks, relationships, or systems other than those considered in the operational characteristics (dimensions, weight, etc.).

10. LIFE CYCLE COST ASSESSMENT. The following costs are based on an NDI-B approach and are in FY90 Constant \$ (Thousands).

a. Development	2,399
b. Production	275,013
c. Military construction	0
d. Fielding	11,149
e. Sustainment	38,599
f. Design to Cost Goal	

11. MILESTONE SCHEDULE.

- | | | |
|----|-----------------|--------|
| a. | ROC approval | 2QFY91 |
| b. | MDR I/III (IPR) | 3QFY91 |
| c. | TT/IOTE | 2QFY93 |
| d. | IOC | 2QFY94 |

(5)

APPENDIX 1
(OPERATIONAL CHARACTERISTICS)
FOR THE
HIGH MOBILITY TRAILER

1. The HMT must provide the following features and characteristics.

a. Compatibility with existing systems.

(1) Be capable of being towed by the HMMWV IAW the Operational Mode Summary/Mission Profile (OMS/MP) (See Appendix 5) and within the Gp I/II HMMWV's allowable vertical tongue weight (200 pounds). It is desired that the HMT be capable of meeting the 4200 pound towed load allowance of the Gp III HMMWV variant and be capable of being towed by all 5 ton and smaller tactical wheeled vehicles in the Army inventory.

(2) Be capable of operating with run-flat tires. The Air Force desires that the trailer be capable of operating 3 hours at 30 mph on run-flat tires.

(3) Be capable of operating an electrical system which is compatible to the HMMWV's, operates throughout all trailer operating conditions, and which includes Army Secure Lighting.

(4) Must possess a cargo bed with internal dimensions of 7' X 4' and be capable of mounting special purpose beds to the trailer chassis (for example: power generation units) or to a flat bed in place of a standard HMT cargo bed.

b. Transportability and mobility:

(1) Meet all parameters of the Operational Mode Summary/Mission Profile (OMS/MP) and under conditions of rain, fog, haze, snow and dust. It is desirable that the HMT possess a low center of gravity.

(2) At Gross Vehicle Weight (GVW), be capable of meeting or only marginally degrading (less than or equal to 10 per cent) the mobility characteristics of the HMMWV.

(3) Be capable of having the same tire width/track as the HMMWV.

(4) Be capable of providing a suspension system that provides ride dynamics comparable to the HMMWV.

(1-1)

- (5) Possess a departure angle of at least 45 degrees.
- (6) Must be capable of following the HMMWV, when coupled, in its minimum turning circle without cramping, damaging the trailer or prime mover, and without causing interference between the trailer and HMMWV.
- (7) The trailer lunette must be long enough to preclude the cargo cover bow kit from striking the cargo cover kit or shelter on the HMMWV when being towed up or down a 60 degree slope.
- (8) Be capable of fording 30 inches or a depth equal to that of the prime mover, of salt or fresh water, without a kit and be equipped with a method of draining residues from the trailer bed.
- (9) Must possess ground clearance of at least 16 inches and be capable of being towed over an 18 inch vertical step by the HMMWV.
- (10) Must be internally air transportable with prime mover by C-130 and larger aircraft. The HMT, at GVW, must be transportable without restriction by marine, rail and US and NATO highway modes. The trailer must have military standard lifting and tiedown provisions. The HMT, at GVW, must be externally transportable by UH-60A, L, M models as a single load and CH-47D, CH-53 with its prime mover. It is desired that the HMT be internally transportable on a CH-47D aircraft (maximum trailer width of less than 75 inches).
- (11) The overall trailer length cannot exceed 132 inches.
- (12) The trailer must not oscillate from side to side while being towed at highway speeds.
- (13) At Gross Combined Weight (GCW), be capable of negotiating a 40 per cent side slope and ascending/descending 40 per cent longitudinal grades without slipping or overturning. The parking brake should hold the HMT at GVW on a 30 per cent longitudinal grade.

(1-2)

(14) It is desired that the HMT be capable of towing another HMT under emergency conditions (i.e.. a towing pintle on the rear).

c. Reliability, availability, and maintainability (RAM).

(1) Maintenance Ratio (MR) and Mean Miles Between Operational Mission Failure (MMPOMF) will be provided in the RAM Rationale Report prior to ROC approval. (See Appendix 4.)

(2) Be capable of limiting operator level PMCS checks to before, during, after and weekly checks. Before operation and after operation checks will take no longer than 5 minutes. Scheduled services and lubrications will be accomplished on a semiannual basis and must be completed within 8 man-hours. Trailer design will enable organizational maintenance crews to replace component assemblies/subassemblies within 2 man-hours.

(3) Be capable of allowing the operator to detect 95% of equipment faults and organizational maintenance personnel to repair 90% of these faults.

d. Standardization:

(1) Be capable of interchanging parts such as tools, seals, fittings, tires, and wheels which are common with its prime mover.

(2) Be capable of accepting existing special mission/environmental kits (arctic kits, cargo cover and bow kits (with 6 foot height clearance and that are NBC contamination/decontamination survivable), camouflage covers, and weapons rack kits (M16)). It is desirable that future kits also be accepted (i.e..auxillary power kits (APU) and brake).

(3) Possess certified, recessed internal cargo tiedowns.

(4) Must possess safety chains which meet all Federal Motor Vehicle Safety Standards, and which will prevent trailer separation from the HMMWV during failure of the towing pintle.

(5) Must possess identification plates and markings that conform to all applicable military standards.

(6) Be capable of stopping the trailer at GVW with a service or surge brake and possess an independent, manually operated parking brake which meets Department of Transportation (DOT) standards.

(7) Must possess a pedestal/retractable mount/leg in the tongue so that the trailer, at GVW, can be stored level. It is desired that the pedestal leg possess a wheel.

(8) Must have sidewalls and endwalls that are capable of supporting the entire weight of a full capacity payload.

(9) Must meet ammunition transport certification.

e. Nuclear and NBC contamination survivability: The trailer and kits must be capable of surviving NBC contamination and decontamination procedures and agents and be Chemical Agent Resistant Coating (CARC) painted in three color camouflage patterns.

f. Adverse weather: Be capable of operating worldwide in hot, basic, and cold climatic conditions as outlined in AR 70-38 and under conditions of rain, fog, haze, snow, and dust.

g. Airdrop, airlift certification, and jumpack:

(1) The HMT must meet External Air Transport (EAT) certification as a single point load, dual point load, and a tandem load with its prime mover.

(2) Must be capable at maximum GVW of low altitude parachute extraction system (LAPES) and low velocity air drop (LVAD) both as a single load and with its prime mover.

(3) Lifting provisions must meet dimensional (3.0 to 3.2 inch inside diameter) and strength (3.2 times the working load) requirements.

h. Lighten the force:

(1) Be capable of carrying a payload of 1500-2500 pounds without exceeding the towed load allowance for the Gp I/II HMMWV variants (3400 pounds). Payload includes special mission kits, crew, crew gear, mission equipment, Basic Issue Items (BII), and pintle weight.

(2) Be capable of being rapidly coupled and uncoupled by two soldiers, one of whom is a 5th percentile female.

i. Preplanned Product Improvements. Must accommodate modifications of the axles, lunettes, cargo bed, chassis, and functional kits that shall make it compatible with other Army prime movers.

j. Must be equipped with a fold down, removable tailgate.

k. Must be capable of being viewed by the operator in the prime mover's rear view mirror when towed, whether empty or loaded.

l. It is desired that the HMT possess stabilizer legs which will enable the trailer to remain stable at GVW during static operations on uneven ground when standing by itself.

m. It is desired that the HMT possess a nonskid, anti-spark cargo bed surface.

(1-5)

APPENDIX 2
(RATIONALE)
FOR THE
HIGH MOBILITY TRAILER

The following rationale statements correspond to the subparagraphs of Appendix 1, Operational Characteristics.

1. The HMT must:

a. Compatibility with existing systems.

(1) Be capable of being towed by the HMMWV IAW the Operational Mode Summary/Mission Profile (OMS/MP) (See Appendix 5) and within the Gp I/II HMMWV's allowable vertical tongue weight (200 pounds). It is desired that the HMT be capable of meeting the 4200 pound towed load allowance of the Gp III HMMWV variant and be capable of being towed by all 5 ton and smaller tactical wheeled vehicles in the Army inventory.

RATIONALE: The HMT will increase the mobility of the HMMWV equipped units that are currently using the M101 series trailer in this role. The lack of mobility of the M101 series trailer poses a roll over hazard when pulled behind a HMMWV. The HMT will solve this safety deficiency. The HMMWV's allowable tongue weight is 200 pounds. Remaining within this limitation will ensure the trailer can be towed by the HMMWV. Meeting the 4200 pound towed load allowance of the Gp III HMMWV will preclude vehicular overloads that degrade mobility and cause safety hazards.

(2) Be capable of operating with run-flat tires. The Air Force desires that the trailer be capable of operating 3 hours at 30 mph on run-flat tires.

RATIONALE: The HMT will increase the mobility and number of parts in common with the HMMWV, thereby reducing the logistics support currently required with the M101 series trailer. Not requiring a spare tire will also increase the available payload over the current 3/4 ton trailer.

(3) Be capable of operating an electrical system which is compatible to the HMMWV's, operates throughout all trailer operating conditions, and which includes Army Secure Lighting.

(2-1)

RATIONALE: This feature ensures the safe operation of the trailer during convoy operations under blackout conditions.

(4) Must possess a cargo bed with internal dimensions of 7' X 4' and be capable of mounting special purpose beds to the trailer chassis (for example: power generation units) or to a flat bed in place of a standard HMT cargo bed.

RATIONALE: A cargo bed with dimensions of 7' X 4' will allow Chemical users to carry the XM56 Dual Purpose Smoke Generator/Decontamination System on a single trailer thereby reducing the number of assets required to accomplish a single mission without having to wait for future technology to develop, overload current assets, or depend on obsolete or shortage equipment. The ability to mount special purpose beds to the cargo bed or a trailer chassis will improve the flexibility and availability of the HMT.

b. Transportability and mobility:

(1) Meet all parameters of the Operational Mode Summary/Mission Profile (OMS/MP) and under conditions of rain, fog, haze, snow and dust. It is desirable that the HMT possess a low center of gravity.

RATIONALE: Rapid movement of the HMMWV with HMT on the battlefield dictates that it can negotiate the OMS/MP that reflects the variety of mission profiles and climatic conditions that may be presented. Speeds shown are those that the mission requires without overstressing the vehicles, on-board components, or towed loads. A low center of gravity is needed to allow the safe operation of antennas, masts and other top heavy equipment/cargo while preventing the overturning or tipping of the trailer during cross country operations.

(2) At Gross Vehicle Weight (GVW), be capable of meeting or only marginally degrading (less than or equal to 10 per cent) the mobility characteristics of the HMMWV.

RATIONALE: Mobility degradation of not more than 10-20% will retain the cross country mobility of the HMMWV. The base case for mobility measurements is the M998 coupled with the current 3/4 ton trailer. Mobility of the system greater than the base case will enhance mission effectiveness.

(2-2)

(3) Be capable of having the same tire width/track as the HMMWV

RATIONALE: The same track will prevent tipping and reduce the rough ride from trailer oscillation between the tracks of a HMMWV of a different width. Track width becomes important during movement through snow, mud, and soft sand. If the trailer does not track with the prime mover, snowplowing occurs and decreases the mobility of the system.

(4) Be capable of providing a suspension system that provides ride dynamics comparable to the HMMWV.

RATIONALE: Comparable ride dynamics between the truck and the trailer will enhance mobility over the current 3/4 ton trailer which tends to oscillate behind the HMMWV. The oscillation and bouncing of the trailer cause severe damage to power generation equipment mounted in the trailer.

(5) Possess a departure angle of at least 45 degrees.

RATIONALE: This feature will prevent the trailer from impeding the mobility of the HMMWV when traversing slopes and humps during cross country movement.

(6) Must be capable of following the HMMWV, when coupled, in its minimum turning circle without cramping, damaging the trailer or prime mover, and without causing interference between the trailer and HMMWV.

RATIONALE: The HMT will improve the mobility of the HMMWV/HMT system while reducing unscheduled maintenance manpower to repair dents in the HMMWV and HMT.

(7) The trailer lunette must be long enough to preclude the cargo cover bow kit from striking the cargo cover kit or shelter on the HMMWV when being towed up or down a 60 degree slope.

RATIONALE: The length of the lunette, when coupled with its prime mover, will help reduce damage to both cargo and system vehicles incurred by high silhouetted cargo on the prime mover striking high silhouetted cargo on the trailer, thereby improving mobility over the current 3/4 ton series trailers.

(2-3)

(8) Be capable of fording 30 inches or a depth equal to that of the prime mover, of salt or fresh water without a kit and be equipped with a method of draining residues from the trailer bed.

RATIONALE: The truck and trailer travel as a system. The fording capability of the HMMWV without fording kit is 30 inches and varies with the prime mover. The trailer is expected to follow the HMMWV within this profile. A method of draining residues from the trailer bed is needed to reduce corrosion and rust formation and failure, and subsequent maintenance requirements, thereby improving the availability and maintainability of the HMT over the current M101 series trailer.

(9) Must possess a ground clearance of at least 16 inches and be capable of being towed over an 18 inch vertical step by the HMMWV.

RATIONALE: A 16 inch ground clearance will improve the mobility over the M101 series trailer while being compatible with that of the HMMWV.

(10) Must be internally air transportable with prime mover by C-130 and larger aircraft. The HMT, at GVW, must be transportable without restriction by marine, rail and US and NATO highway modes. The trailer must have military standard lifting and tiedown provisions. The HMT, at GVW, must be externally transportable by UH-60A, L, M models as a single load and CH-47D, CH-53 with its prime mover. It is desired that the HMT be internally transportable on a CH-47D aircraft (maximum trailer width of less than 75 inches).

RATIONALE: All vehicles must adhere to NATO Standard Agreements regarding highway legal load limits. These load limits are also enforced in the Continental U.S. Military standard lifting and tiedown provisions are essential to allow shipment of the HMT by rail, sea, and air. Rail transport reduces wear and tear on tactical vehicles, minimizes en route support, and reduces maintenance requirements. Transport by marine mode is required for logistics over the shore (LOTS) operations. The HMT with the HMMWV must be capable of intra/intertheater transport by aircraft for rapid deployment. External helicopter transport provides operational flexibility when it is not feasible to transport by tactical aircraft.

(2-4)

Simultaneous external transport of the truck and trailer as a system by the CH-47D and CH-53 provide rapid employment of the system and more efficient use of transport assets. Joint operations may require lift of the HMT by the CH-53.

(11) The overall trailer length cannot exceed 132 inches.

RATIONALE: An overall length of ≤ 132 inches will allow the HMT to be coupled with the HMMWV on board Air Force C-130 aircraft, the smallest, most restrictive Air Force aircraft, during tactical airlifts as well as LAPES and LVAD operations.

(12) The trailer must not oscillate from side to side while being towed at highway speeds.

RATIONALE: Elimination of side to side oscillation will enhance the safe operation of the vehicle-trailer system.

(13) At Gross Combined Weight (GCW), be capable of negotiating a 40 per cent side slope and ascending/descending longitudinal grades of 40 per cent without slipping or overturning. The parking brake should hold the HMT at GVW on a 30 per cent longitudinal grade.

RATIONALE: The HMT will improve mobility over the M101 series trailers while being compatible with that of the HMMWV.

(14) It is desired that the HMT be capable of towing another HMT under emergency conditions (i.e. a towing pintle on the rear).

RATIONALE: This capability will allow the HMT to be towed short distances by another system under emergency conditions where one prime mover has been disabled and there is no other available or no time available to wait for another to arrive.

c. Reliability, availability, and maintainability (RAM).

(1) Maintenance Ratio (MR) and Mean Miles Between Operational Mission Failure (MMBOMF) will be provided in the RAM Rationale Report prior to ROC approval. (See Appendix 4.)

(2-5)

RATIONALE: This data is still pending. It will be provided with the RAM Rationale Report (Appendix 4) prior to Required Operational Capability (ROC) approval.

(2) Be capable of limiting operator level PMCS checks to before, during, after and weekly checks. Before and after operation checks will take no longer than 5 minutes. Scheduled services and lubrications will be accomplished on a semiannual basis. Trailer design will enable organizational maintenance crews to replace component assemblies/subassemblies within 2 man-hours.

RATIONALE: The HMT, as an augmentation vehicle, must not add significantly to the manpower or skills already required to operate or maintain the prime mover.

(3) Be capable of allowing the operator to detect 95% of equipment faults and organizational maintenance personnel to repair 90% of these faults.

RATIONALE: By limiting the maintenance time required to repair the HMT or replace component/subassembly parts, it will become an improvement over the current trailer. These parameters will insure that the trailer has a simple design that can be easily fixed/repared, thereby keeping maintenance manpower at the current levels.

d. Standardization:

(1) Be capable of interchanging parts such as tools, seals, fittings, tires, and wheels which are common with its prime mover.

RATIONALE: Commonality between the truck and the trailer eases the burden on the logistics system. This also results in fewer tools required at all levels of maintenance which in turn reduces the weight carried by crews on the truck.

(2) Be capable of accepting existing special mission/environmental kits. For example: arctic kits, cargo cover and bow kits (with 6 foot height clearance and that are NBC contamination/decontamination survivable), camouflage covers, and weapons rack kits (M16). It is desirable that future kits also be accepted (i.e.. auxillary power kits (APU) and brake).

(2-6)

RATIONALE: The HMT will improve the standardization and availability of use with known payloads, both current and future.

(3) Possess certified, recessed internal cargo tiedowns.

RATIONALE: Recessed tiedowns allow for the full use of the cargo compartment. Cross-country operations require cargo restraint. Certification will standardize tiedown materials, insure they are acceptable for air transport, and improve the safety and security of the cargo while being transported.

(4) Must possess safety chains which meet all Federal Motor Vehicle Safety Standards, and which will prevent trailer separation from the HMMWV during failure of the towing pintle.

RATIONALE: The HMT will reduce system safety hazards by possessing chains which will prevent the trailer from separating from the HMMWV should the towing pintle fail.

(5) Must have identification plates and markings that conform to all applicable military standards.

RATIONALE: The HMT will standardize system identification with these plates and improve personnel identification of the trailer without increasing health hazards to users.

(6) Be capable of stopping the trailer at GVW with a service or surge brake and possessing an independent manually operated parking brake which meet Department of Transportation (DOT) standards.

RATIONALE: The service or surge brake system will allow for safe stopping of the trailer under all road conditions and loading combinations IAW the CMS/MP. A minimum of 30 feet on dry pavement from 20 mph is the least acceptable. Improvements on this criteria will enhance safe operations of the vehicle-trailer combination. Additionally, a manually operated parking brake is needed to hold the trailer on level ground when not coupled to the HMMWV.

(7) Must possess a pedestal/retractable mount/leg in the tongue so that the trailer, at GVW, can be stored level. It is desired that the pedestal leg possess a wheel.

(2-7)

RATIONALE: The pedestal/retractable leg in the tongue will allow the trailer, at GVW, to be stowed on the level. A wheel in the pedestal mount will reduce the health hazards associated with soldiers pulling the trailer short distances.

(8) Must have sidewalls and endwalls that are capable of supporting the entire weight of a full capacity payload.

RATIONALE: This designed-in strength will reduce injuries and accidents caused by endwalls or sidewalls failing under sudden deceleration or other movements.

(9) Must meet ammunition transport certification.

RATIONALE: One of the HMT's primary missions will be to carry basic loads for Special Forces and Military Police who are on long range patrol. Ammunition certification is required to ensure the safety of the cargo as well as the system operators.

e. Nuclear and NBC contamination survivability: The trailer and kits must be capable of surviving NBC contamination and decontamination procedures and agents and be Chemical Agent Resistant Coating (CARC) painted in camouflage patterns.

RATIONALE: In order to reduce degradation of the HMMWV/HMT system due to NBC contamination, the HMT must be survivable in this environment. CARC will ease the decontamination procedures for the trailer. Camouflage patterns are an operations security measure aimed at lowering vehicle detection from the air.

f. Adverse weather: Be capable of operating worldwide in hot, basic, and cold climatic conditions as outlined in AR 70-38 and under conditions of rain, fog, haze, snow, and dust.

RATIONALE: The HMT and HMMWV are a system and must travel over the same conditions and operate in the same weather. Units moving to field locations use convoy procedures that require following a lead vehicle. Therefore, the trailer must be equipped to operate during conditions of reduced visibility.

(2-8)

g. Airdrop, airlift certification, and jumppack:

(1) The HMT must meet External Air Transport (EAT) certification as a single point load, dual point load, and a tandem load with its prime mover.

RATIONALE: The HMT will increase standardization and improve transportability over the current M101 series trailer and be certified as an external load for rotary aircraft which can deliver it as a tactical load under adverse conditions (i.e.. a hot landing zone).

(2) Must be capable at maximum GVW of low altitude parachute extraction system (LAPES) and low velocity air drop (LVAD) both as a single load and with its prime mover.

RATIONALE: LAPES and LVAD capability provide alternate insertion methods and are consistent with the like capability of the HMMWV. LAPES and LVAD of the HMMWV and HMT as a system reduces insertion time and more efficiently uses transport assets.

(3) Lifting provisions must meet dimensional (3.0 to 3.2 inch inside diameter) and strength (3.2 times the working load) requirements.

RATIONALE: This feature will insure a margin of safety when lifting the HMT.

h. Lighten the force:

(1) Be capable of carrying a payload of 1500-2500 pounds without exceeding the towed load allowance for the Group I/II HMMWV variants (3400 pounds). Payload includes special mission kits, crew, crew gear, mission equipment, Basic Issue Items (BII), and pintle weight.

RATIONALE: The preponderance of truck/trailer systems will use the Group I/II vehicles as the prime mover. Not exceeding the towed load allowance of these vehicles will preclude vehicular overloads that degrade mobility and cause safety hazards.

(2) Be capable of being rapidly coupled and uncoupled by two soldiers, one of which is a 5th percentile female.

(2-9)

RATIONALE: The HMT will improve system availability over the M101 series trailer by insuring any assigned female can, with the aide of another person, rapidly couple/uncouple the HMT from its prime mover.

i. Preplanned Product Improvements. Must accommodate modifications of the axles, lunettes, cargo bed, chassis, and functional kits that shall make it compatible with other Army prime movers.

RATIONALE: The HMT will improve mobility, maintainability, survivability, and availability through future technological advances and designs. These will continue to make the HMT a viable trailer.

j. Must be equipped with a fold down, removable tailgate.

RATIONALE: A fold down, removable tailgate will facilitate cargo loading and unloading. In addition, during travel over rough terrain, the tailgate will act as an additional cargo restraint if the tiedowns break. A removable tailgate will facilitate the mounting of shelters and loading/unloading bulky or heavy cargo items.

k. Must be capable of being viewed by the operator in the prime mover's rear view mirror when towed, whether empty or loaded.

RATIONALE: This feature ensures the safe operation of both the trailer and the prime mover during operations which include tight turns, backing, rough terrain, and hours of darkness.

l. It is desired that the HMT possess stabilizer legs which will enable the trailer to remain stable at GVW during static operations on uneven ground when standing by itself and on those occasions when 2-4 people operate from within a shelter.

RATIONALE: Stabilizer legs allow for level stowing of the trailer on uneven ground or while performing static missions when it is not coupled to the HMMWV, especially at GVW.

m. It is desired that the HMT possess a nonskid, anti-spark cargo bed surface.

(2-10)

RATIONALE: The HMT, when used to transport Class III and V supplies, must meet safety requirements for carrying hazardous cargo.

(2-11)

APPENDIX G

NOMENCLATURE

Appendix G
NOMENCLATURE

N_v	Normal force on prime mover (HMMWV) [Lbs]
N_{vr}	Normal force on rear tires of prime mover [Lbs]
N_{vf}	Normal force on front tires of prime mover [Lbs]
W_v	Weight of prime mover (HMMWV) [Lbs]
W_{vr}	weight on rear tires [Lbs]
W_{vf}	weight on front tires [Lbs]
β	slope angle [degrees]
W_t	Weight of trailer [Lbs]
a	Deceleration of system [ft/s ²]
m	Mass of system [slugs]
F_f	Frictional force [Lbs]
μ	Coefficient of tire/road adhesion
g	Gravitational constant [ft/s ²]
k	Weight ratio
v	Initial velocity [ft/s]
h	Altitude change [ft]
d	Braking distance [ft]
T_b	HMMWV Braking torque [in Lbs]
F_{ob}	HMMWV Brake pad force [Lbs]
r_r	Effective radius of HMMWV rotor [in]
u	HMMWV Coefficient of pad/rotor friction
T_t	HMMWV Traction torque [in Lbs]
r_t	Tire radius [in]
T_s	Trailer braking torque [in Lbs]
F_s	Force applied to surge brake cylinder [Lbs]
F_t	Force trailer applies to the HMMWV [Lbs]
N_t	Trailer normal force [Lbs]
a_t	Trailer deceleration [rad/s ²]
m_t	Trailer mass [slugs]
r_s	Effective radius of the trailer's rotor [ft]
d_e	Energy distance of the HMMWV [ft]
μ_{sp}	Coefficient of friction of the trailer's brake pads
d_r	Radial distance the HMMWV rotor turns with pad applied [ft]
ϕ	Angle the HMMWV rotor turns with pad applied [radians]

APPENDIX H

HMMWV BRAKE BIAS TEST DATA

TEST NUMBER: MPG02160

6 Mar 1990

14:26:08

VEHICLE NUMBER: NG291J MILEAGE: 50000
 YEAR: 1990 MAKE: MILITARY MODEL: HMMWV BODY CODE: MILITARY#
 WHEELBASE: 120.0 in. STATIC C. G. HEIGHT: 70.0 in.
 FRONT TRACK: 0.0 in. REAR TRACK: 0.0 in. PRODUCTION: UNKNOWN
 REQUESTER: ALEXANDER SPONSOR: BBSC DRIVER: GOSBETH
 TEMPERATURE: +72 F REL. HUMIDITY: 65.1 %
 *** COMMENTS ***

*** KEYWORDS ***

	LF (lbs)	RF (lbs)	LR (lbs)	RR (lbs)	FRONT (lbs)	REAR (lbs)	TOTAL (lbs)	% REAR
STATIC WEIGHT	+1741	+1780	+2401	+2485	+3521	+4887	+8408	58.1
1 FORE/AFT	+982	+1066	+705	+617	+2048	+1322	+3370	39.2
VERTICAL	+2134	+2190	+1871	+2026	+4324	+3897	+8222	47.4
LATERAL	-416	+377	+253	-203	-39	+50	110	
MPH=33.3	L=+.40	WIND= 7 FROM	88	STATUS=OK				
LINE PRESSURE	0	0	0	0				
TEMPERATURE	0	0	0	0				
PEDAL FORCE	0							
2 FORE/AFT	+561	+641	+607	+564	+1202	+1171	+2373	49.4
VERTICAL	+2002	+2193	+2014	+2098	+4194	+4112	+8307	49.5
LATERAL	-348	+337	+188	-184	-11	+4	-7	
MPH=34.1	DECEL=+.28	WIND= 6 FROM	95	STATUS=OK				
LINE PRESSURE	0	0	0	0				
TEMPERATURE	0	0	0	0				
PEDAL FORCE	0							
3 FORE/AFT	+435	+518	+567	470	+954	+1037	+1990	52.1
VERTICAL	+1915	+1964	+1990	1176	+3879	+4167	+8046	51.8
LATERAL	-352	+294	+221	-209	-59	+12	-47	
MPH=39.1	DECEL=+.24	WIND= 5 FROM	35	STATUS=OK				
LINE PRESSURE	0	0	0	0				
TEMPERATURE	0	0	0	0				
PEDAL FORCE	0							
4 FORE/AFT	+1326	+1430	+794	+573	+2756	+1367	+4123	39.2
VERTICAL	+2189	+2551	+1538	+1532	+4741	+3070	+7810	39.3
LATERAL	-407	+579	+292	-6	+172	+286	+458	
MPH=40.0	DECEL=+.49	WIND= 5 FROM	205	STATUS=MISSED PAD				
LINE PRESSURE	0	0	0	0				
TEMPERATURE	0	0	0	0				
PEDAL FORCE	0							

BRAKE DISTRIBUTION vs DECELERATION
 FOR VARIOUS ROAD COEFFICIENTS OF FRICTION
 CAR# NG291J WHEELBASE=120 in. CG HT=78 in. 6 Mar 1990
 HMMWV FRT WT/TOTAL=3521/8408(LBS) =41.9%
 NPG02160

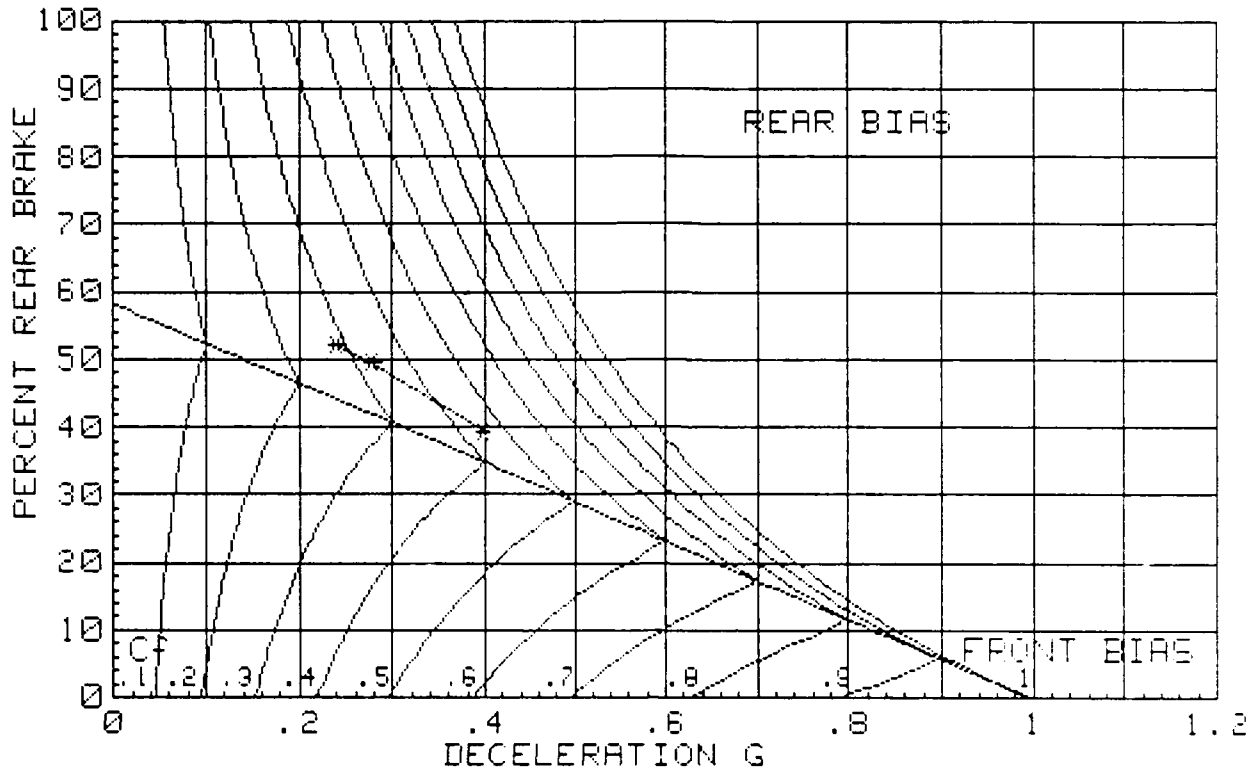

CAR# NG291J WHEELBASE=120 in. CG HT=78 in. 6 Mar 1990
 HMMWV FRT WT/TOTAL=3521/8408(LBS) =41.9%

NPG02160

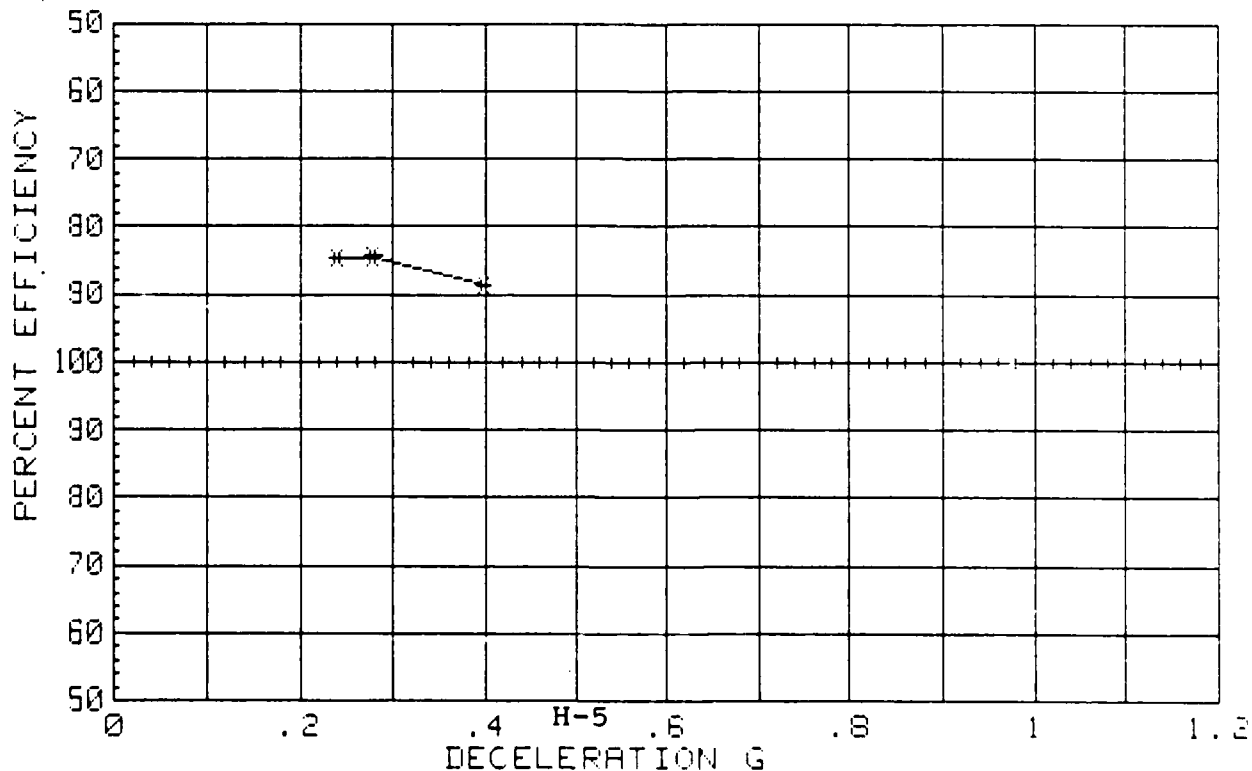

APPENDIX I

FEDERAL MOTOR CARRIER SAFETY REGULATIONS 393.42 - 393.52



US Department
of Transportation
**Federal Highway
Administration**
Bureau of
Motor Carrier Safety

Federal Motor Carrier Safety Regulations & Noise Emission Requirements

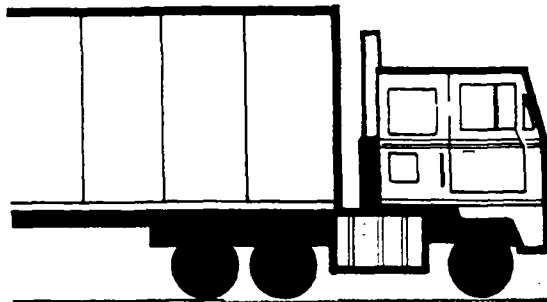

October 31, 1983

Title 49 — Transportation

CHAPTER III — FEDERAL HIGHWAY ADMINISTRATION

DEPARTMENT OF TRANSPORTATION

Subchapter B — Federal Motor Carrier Safety Regulations

and

Interstate Motor Carrier Noise Emission Compliance Regulations

For sale by the Superintendent of Documents, U.S. Government Printing Office
Washington, D.C. 20402

§ 393.33

Title 49—Transportation

are prohibited. Precaution shall be taken to provide sufficient slack in the connecting wire or cable to accommodate without damage all normal motions of the parts to which they are attached.

§ 393.33 Wiring, installation.

Electrical wiring shall be systematically arranged and installed in a workmanlike manner. All detachable wiring, except temporary wiring connections for driveaway-towaway operations, shall be attached to posts or terminals by means of suitable cable terminals which conform to the SAE Standard¹ for "Cable Terminals" or by cable terminals which are mechanically and electrically at least equal to such terminals. The number of wires attached to any post shall be limited to the number which such post was designed to accommodate. The presence of bare, loose, dangling, chafing, or poorly connected wires is prohibited.

Subpart C—Brakes

§ 393.40 Required brake systems.

(a) *General.* A bus, truck, truck tractor, or a combination of motor vehicles must have brakes adequate to control the movement of, and to stop and hold, the vehicle or combination of vehicles.

(b) *Specific systems required.* (1) A bus, truck, truck tractor, or combination of motor vehicles must have—

(i) A service brake system that conforms to the requirements of § 393.52; and

(ii) A parking brake system that conforms to the requirements of § 393.41.

(2) A bus, truck, truck tractor, or a combination of motor vehicles manufactured on or after July 1, 1973, must have an emergency brake system that conforms to the requirements of § 393.52(b) and consists of either—

(i) Emergency features of the service brake system; or

(ii) A system separate from the service brake system.

A control by which the driver applies the emergency brake system must be located so that the driver can readily

¹See footnote 1 to § 393.24(c).

operate it when he is properly restrained by any seat belt assembly provided for his use. The control for applying the emergency brake system may be combined with either the control for applying the service brake system or the control for applying the parking brake system. However, all three controls may not be combined.

(c) *Interconnected systems.* (1) If the brake systems specified in paragraph (b) of this section are interconnected in any way, they must be designed, constructed, and maintained so that, upon the failure of any part of the operating mechanism of one or more of the systems (except the service brake actuation pedal or valve)—

(i) The vehicle will have operative brakes; and

(ii) In the case of a vehicle manufactured on or after July 1, 1973, the vehicle will have operative brakes capable of performing as specified in § 393.52(b).

(2) A motor vehicle to which the emergency brake system requirements of Federal Motor Vehicle Safety Standard No. 105 (§ 571.105 of this title) applied at the time of its manufacture conforms to the requirements of paragraph (c)(1) of this section if—

(i) It is maintained in conformity with the emergency brake requirements of Standard No. 105 in effect on the date of its manufacture; and

(ii) It is capable of performing as specified in § 393.52(b), except upon structural failure of its brake master cylinder body or effectiveness indicator body.

(3) A bus conforms to the requirements of paragraph (c)(1) of this section if it meets the requirements of § 393.44 and is capable of performing as specified in § 393.52(b).

[36 FR 20297, Oct. 20, 1971, as amended at 37 FR 5251, Mar. 11, 1972]

§ 393.41 Parking brake system.

(a) Every singly driven motor vehicle and every combination of motor vehicles shall at all times be equipped with a parking brake system adequate to hold the vehicle or combination on any grade on which it is operated under any condition of loading on a surface free from ice or snow.

(b) The parking brake system shall at all times be capable of being applied in conformance with the requirements of paragraph (a) of the section by either the driver's muscular effort, or by spring action, or by other energy, provided, that if such other energy is depended on for application of the parking brake, then an accumulation of such energy shall be isolated from any common source and used exclusively for the operation of the parking brake.

(c) The parking brake system shall be held in the applied position by energy other than fluid pressure, air pressure, or electric energy. The parking brake system shall be such that it cannot be released unless adequate energy is available upon release of the parking brake to make immediate further application with the required effectiveness.

[34 FR 15418, Oct. 3, 1969]

§ 393.42 Brakes required on all wheels.

Every motor vehicle shall be equipped with brakes acting on all wheels, except:

(a) Any full trailer, semitrailer, or pole trailer of a gross weight not exceeding 3,000 pounds: *Provided*, That the gross weight of any such full trail-

er or pole trailer, no part of the load of which rests upon the towing vehicle, shall not exceed 40 percent of the gross weight of the towing vehicle and that the gross weight of any such semitrailer or pole trailer part of the load of which rests upon the towing vehicle, shall not exceed 40 percent of the gross weight of the towing vehicle when connected to such semitrailer or pole trailer;

(b) Any vehicle being towed in a driveaway-towaway operation, provided the combination of vehicles is capable of complying with the performance requirements of § 393.52; only such brakes on the vehicle or vehicles being towed in driveaway-towaway operations need be operative as may be necessary to insure compliance with the performance requirements of § 393.52. This paragraph is not applicable to any motor vehicle towed by means of a tow-bar when any vehicle is full-mounted on such motor vehicle or any combination of motor vehicles utilizing three saddle-mounts.

(c) Trucks and truck tractors having three or more axles need not have brakes on the front wheels, except when such vehicles are equipped with at least two steerable axles the wheels of one such axle need not be equipped with brakes.

(Diagrams to illustrate § 393.42 for brake requirements for light trailers.)

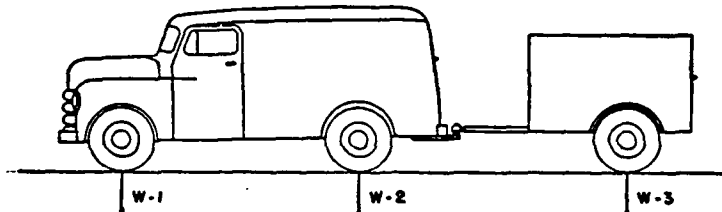

(Semitrailer or 2-wheel pole trailer of 3,000 pounds gross weight or less must be equipped with brakes if W-3 is greater than 40 percent of the sum of W-1 and W-2.)

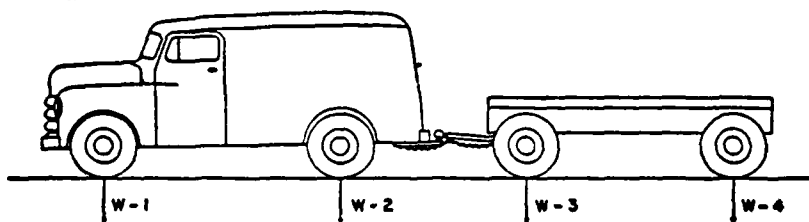

(Full trailer or 4-wheel pole trailer of 3,000 pounds gross weight or less must be equipped with brakes if the sum of W-3 and W-4 is greater than 40 percent of the sum of W-1 and W-2.)

(Sec. 12, 80 Stat. 931; 49 U.S.C. 1651 note)

§ 393.43 Breakaway and emergency braking.

(a) Every motor vehicle, if used to tow a trailer equipped with brakes, shall be equipped with means for providing that in case of breakaway of such trailer the service brakes on the towing vehicle will be sufficiently operative to stop the towing vehicle.

(b) Every truck or truck tractor equipped with air brakes, when used for towing other vehicles equipped with air brakes, shall be equipped with two means of activating the emergency features of the trailer brakes. One of these means shall operate automatically in the event of reduction of the towing vehicle air supply to a fixed pressure which shall not be lower than 20 pounds per square inch nor higher than 45 pounds per square inch. The other means shall be a manually controlled device readily operable by a person seated in the driving seat. Its emergency position or method of oper-

ation shall be clearly indicated. In no instance may the manual means be so arranged as to permit its use to prevent operation of the automatic means. The automatic and manual means required by this section may be, but are not required to be, separate.

(c) Every truck tractor and truck when used for towing other vehicles equipped with vacuum brakes, shall have, in addition to the single control required by § 393.49 to operate all brakes of the combination, a second manual control device which can be used to operate the brakes on the towed vehicles in emergencies. Such second control shall be independent of brake air, hydraulic, and other pressure, and independent of other controls, unless the braking system be so arranged that failure of the pressure on which the second control depends will cause the towed vehicle brakes to be applied automatically. The second control is not required by this rule to

provide modulated or graduated braking.

(d) Every trailer required to be equipped with brakes shall be equipped with brakes of such character as to be applied automatically and promptly upon breakaway from the towing vehicle, and means shall be provided to maintain application of the brakes on the trailer in such case for at least 15 minutes.

(e) Air brake systems installed on towed vehicles shall be so designed, by the use of "no-bleed-back" relay emergency valves or equivalent devices, that the supply reservoir used to provide air for brakes shall be safeguarded against backflow of air to the towing vehicle upon reduction of the towing vehicle air pressure.

(f) The requirements of paragraphs (b), (c), and (d) of this section shall not be applicable to motor vehicles in driveaway-towaway operations.

§ 393.44 Front brake lines, protection.

On every bus, made after June 30, 1954, if equipped with air brakes, except buses being transported in driveaway-towaway operations, the braking system shall be so constructed that in the event any connection to the brake system forward of the driver's seat or any brake line to any of the front wheels is broken, the driver can apply the brakes on the rear wheels despite such breakage. The means used to apply the brakes on the rear wheels shall be adjacent to but neither forward nor to the left of the driver's seat.

§ 393.45 Brake tubing and hose, adequacy.

(a) *General requirements.* Brake tubing and brake hose must—

(1) Be designed and constructed in a manner that insures proper, adequate, and continued functioning of the tubing or hose;

(2) Be installed in a manner that insures proper continued functioning of the tubing or hose;

(3) Be long and flexible enough to accommodate without damage all normal motions of the parts to which it is attached;

(4) Be suitably secured against chafing, kinking, or other mechanical damage;

(5) Be installed in a manner that prevents it from contacting the vehicle's exhaust system or any other source of high temperatures; and

(6) Conform to the applicable requirements of paragraph (b) or (c) of this section. In addition, all hose installed on and after January 1, 1981, must conform to those applicable subsections of FMVSS 106 (49 CFR 571.106).

(b) *Special requirements for brake hose other than nonmetallic tubing.*

(1) Except as provided in paragraph (c) of this section, brake hose installed on a motor vehicle on or after October 1, 1973, must conform to one of the following specifications:

(i) Hydraulic brake hose: Society of Automotive Engineers (SAE) 1401a, January 1978.

(ii) Automotive Air Brake Hose and Hose Assemblies: SAE Recommended Practice J1402c, July 1976.

(iii) Vacuum Brake Hose: SAE Standard J1403a, March 1973.

(2) Except as provided in paragraph (c) of this section, brake hose installed on a motor vehicle before October 1, 1973, must conform to either—

(i) The applicable specification set forth in paragraph (b)(1) (i), (ii), or (iii) of this section; or

(ii) The applicable specification in the SAE Standard for Automotive Brake Hoses published in the 1952 edition of the SAE Handbook.

(c) *Nonmetallic brake tubing.* Coiled nonmetallic brake tubing may be used for connections between towed and towing vehicles or between the frame of a towed vehicle and the unsprung subframe of an adjustable axle of that vehicle if—

(1) The tubing conforms to the requirements for Type B nonmetallic tubing set forth in SAE Standard J844d, "Nonmetallic Air Brake System Tubing," July 1976;

(2) The coiled tubing has a straight segment (pigtail) at each end that is at least 2 inches in length and is encased in a spring guard or similar device which prevents the tubing from kinking at the fitting at which it is attached to the vehicle; and

(3) The spring guard or similar device has at least 2 inches of closed coils or similar surface at its interface

§ 393.46

with the fitting and extends at least 1¼ inches into the coiled segment of the tubing from its straight segment.

(d) *Brake tubing and brake hose—definition.* As used in this section, "brake tubing" and "brake hose" are conduits or lines used in a brake system to transmit or contain the medium (fluid, air, or vacuum) used to apply force to a motor vehicle's brakes. Brake hose is flexible compared to brake tubing except for coiled nonmetallic brake tubing set forth in paragraph (c) of this section. Brake hose is intended for use in the brake system when movement in the line is anticipated. Brake tubing is intended for use in the brake system when movement in the line is not anticipated.

(49 U.S.C. 304, 1655; 49 CFR 1.48(b) and 301.60)

[38 FR 4333, Feb. 13, 1973, as amended at 44 FR 25457, May 1, 1979; 45 FR 46424, July 10, 1980; 47 FR 47837, Oct. 28, 1982]

§ 393.46 Brake tubing and hose connections.

All connections for air, vacuum, or hydraulic braking systems shall:

(a) Be adequate in material and construction to insure proper continued functioning;

(b) Be designed, constructed, and installed so as to insure, when properly connected, an attachment free of leaks, constrictions, or other defects;

(c) Have suitable provision in every detachable connection to afford reasonable assurance against accidental disconnection;

(d) Have the vacuum brake engine manifold connection at least three-eighths inch in diameter.

(e) If installed on a vehicle on or after January 1, 1981, meet requirements under applicable subsections of FMVSS 106 (49 CFR 571.106).

[33 FR 19735, Dec. 28, 1968, as amended at 44 FR 25457, May 1, 1979]

§ 393.47 Brake lining.

The brake lining on every motor vehicle shall be so constructed and installed as not to be subject to excessive fading and grabbing and shall be adequate in thickness, means of attachment, and physical characteristics to

Title 49—Transportation

provide for safe and reliable stopping of the motor vehicle.

§ 393.48 Brakes to be operative.

(a) *General rule.* Except as provided in paragraphs (b) and (c) of this section, all brakes with which a motor vehicle is equipped must at all times be capable of operating.

(b) *Devices to reduce or remove front-wheel braking effort.* A motor vehicle may be equipped with a device to reduce the braking effort upon its front wheels or, in the case of a three-axle truck or truck tractor manufactured before March 1, 1975, to remove the braking effort upon its front wheels, if that device conforms to, and is used in compliance with, the rules in paragraph (b) (1) or (2) of this section.

(1) *Manually operated devices.* A manually operated device to reduce or remove the front-wheel braking effort must not be—

(i) Installed in a motor vehicle other than a bus, truck, or truck tractor; or

(ii) Installed in a bus, truck, or truck tractor manufactured after February 28, 1975; or

(iii) Used in the reduced mode except when the vehicle is operating under adverse conditions such as wet, snowy, or icy roads.

(2) *Automatic devices.* An automatic device to reduce the front-wheel braking effort by up to 50 percent of the normal braking force, regardless of whether or not antilock system failure has occurred on any axle, must not—

(i) Be operable by the driver except upon application of the control that activates the braking system; and

(ii) Be operable when the pressure that transmits brake control application force exceeds—

(A) 85 psig on air-mechanical braking systems; or

(B) 85 percent of the maximum system pressure in the case of vehicles utilizing other than compressed air.

(c) *Towed vehicle.* Paragraph (a) of this section does not apply to—

(1) A disabled vehicle being towed; or

(2) A vehicle being towed in a driveaway-towaway operation which is exempt from the general rule of

§ 393.42 under paragraph (b) of that section.

(Sec. 204 of the Interstate Commerce Act, as amended (49 U.S.C. 304); sec. 6 of the Department of Transportation Act (49 U.S.C. 1655), and the delegations of authority by the Secretary of Transportation and the Federal Highway Administrator at 49 CFR 1.48 and 301.60, respectively)

[39 FR 26907, July 24, 1974, as amended at 41 FR 29130, July 15, 1976; 41 FR 53031, Dec. 3, 1976]

§ 393.49 Single valve to operate all brakes.

Every motor vehicle, the date of manufacture of which is subsequent to June 30, 1953, which is equipped with power brakes, shall have the braking system so arranged that one application valve shall when applied operate all the service brakes on the motor vehicle or combination of motor vehicles. This requirement shall not be construed to prohibit motor vehicles from being equipped with an additional valve to be used to operate the brakes on a trailer or trailers or as provided in § 393.44. This section shall not be applicable to driveaway-towaway operations unless the brakes on such operations are designed to be operated by a single valve.

§ 393.50 Reservoirs required.

(a) *General.* As provided in paragraph (c) of this section, every bus, truck, and truck tractor made after June 30, 1953, and using air or vacuum for braking, shall be equipped with reserve capacity or a reservoir sufficient to insure a full service brake application with the engine stopped without depleting the air pressure or vacuum below 70 percent of that pressure or degree of vacuum indicated by the gauge immediately before the brake application is made. For purposes of this section, a full service brake application is considered to be made when the service brake pedal is pushed to the limit of its travel.

(b) *Safeguarding of air and vacuum.*
(1) Every bus, truck, and truck tractor, when equipped with air or vacuum reservoirs and regardless of date of manufacture, shall have such reservoirs so safeguarded by a check valve or equivalent device that in the event of failure or leakage in its connection to the

source of compressed air or vacuum the air or vacuum supply in the reservoir shall not be depleted by the leak or failure.

(2) Means shall be provided to establish the check valve to be in working order. On and after May 1, 1966, means other than loosening or disconnection of any connection between the source of compressed air or vacuum and the check valve, and necessary tools for operation of such means, shall be provided to prove that the check valve is in working order. The means shall be readily accessible either from the front, side, or rear of the vehicle, or from the driver's compartment.

(i) In air brake systems with one reservoir, the means shall be a cock, valve, plug, or equivalent device arranged to vent a cavity having free communication with the connection between the check valve and the source of compressed air or vacuum.

(ii) Where air is delivered by a compressor into one tank or compartment (wet tank), and air for braking is taken directly from another tank or compartment (dry tank) only, with the required check valve between the tanks or compartments, a manually operated drain cock on the first (wet) tank or compartment will serve as a means herein required if it conforms to the requirements herein.

(iii) In vacuum systems stopping the engine will serve as the required means, the system remaining evacuated as indicated by the vacuum gauge.

(c) *Application.* This section applies to passenger-carrying vehicles each having a seating capacity of nine or more persons, driver included, and to all property-carrying vehicles and combinations of property-carrying vehicles having three or more axles.

§ 393.51 Warning devices and gauges.

(a) *General.* In the manner and to the extent specified in paragraphs (b), (c), (d), and (e) of this section, a bus, truck, or truck tractor must be equipped with a signal that provides a warning to the driver when a failure occurs in the vehicle's service brake system.

(b) *Hydraulic brakes.* A vehicle manufactured on or after July 1, 1973, and having service brakes activated by hydraulic fluid must be equipped with a warning signal that performs as follows:

(1) If Federal Motor Vehicle Safety Standard No. 105 (§ 571.105 of this title) was applicable to the vehicle at the time it was manufactured, the warning signal must conform to the requirements of that standard.

(2) If Federal Motor Vehicle Safety Standard No. 105 (§ 571.105) was not applicable to the vehicle at the time it was manufactured, the warning signal must become operative, before or upon application of the brakes in the event of a hydraulic-type complete failure of a partial system. The signal must be readily audible or visible to the driver.

(c) *Air brakes.* Except as provided in paragraph (g) of this section, a vehicle (regardless of the date it was manufactured) having service brakes activated by compressed air (air-mechanical brakes) or a vehicle towing a vehicle having service brakes activated by compressed air (air-mechanical brakes) must be equipped, and perform, as follows:

(1) The vehicle must have a low air pressure warning device that conforms to the requirements of either paragraph (c)(1) (i) or (ii) of this section.

(i) If Federal Motor Vehicle Safety Standard No. 121 (§ 571.121 of this title) was applicable to the vehicle at the time it was manufactured, the warning device must conform to the requirements of that standard.

(ii) If Federal Motor Vehicle Safety Standard No. 121 (§ 571.121) was not applicable to the vehicle at the time it was manufactured, the vehicle must have a device that provides a readily audible or visible continuous warning to the driver whenever the pressure of the compressed air in the braking system is below a specified pressure, which must be at least one-half of the compressor governor cutout pressure.

(2) The vehicle must have a pressure gauge which indicates to the driver the pressure in pounds per square inch available for braking.

(d) *Vacuum brakes.* Except as provided in paragraph (g) of this section, a vehicle (regardless of the date it was

manufactured) having service brakes activated by vacuum or a vehicle towing a vehicle having service brakes activated by vacuum must be equipped with—

(1) A device that provides a readily audible or visible continuous warning to the driver whenever the vacuum in the vehicle's supply reservoir is less than 8 inches of mercury; and

(2) A vacuum gauge which indicates to the driver the vacuum in inches of mercury available for braking.

(e) *Hydraulic brakes applied or assisted by air or vacuum.* Except as provided in paragraph (g) of this section, a vehicle having a braking system in which hydraulically activated service brakes are applied or assisted by compressed air or vacuum must be equipped with both a warning signal that conforms to the requirements of paragraph (b) of this section and a warning device that conforms to the requirements of either paragraph (c) or paragraph (d) of this section.

(f) *Maintenance.* The warning signals, devices, and gauges required by this section must be maintained in operative condition.

(g) *Exceptions.* The rules in paragraphs (c), (d), and (e) of this section do not apply to the following vehicles:

(1) Buses having a seating capacity of 10 persons (including the driver) or less; and

(2) Property-carrying vehicles and combinations of property-carrying vehicles which have less than three axles and either—

(i) Were manufactured before July 1, 1973; or

(ii) Have a manufacturer's gross vehicle weight rating of 10,000 pounds or less.

[37 FR 5251, Mar 11, 1972]

§ 393.52 Brake performance.

(a) Upon application of its service brakes, a motor vehicle or combination of motor vehicles must under any condition of loading in which it is found on a public highway, be capable of—

(1) Developing a braking force at least equal to the percentage of its gross weight specified in the table in paragraph (d) of this section;

(2) Decelerating to a stop from 20 miles per hour at not less than the rate specified in the table in paragraph (d) of this section; and

(3) Stopping from 20 miles per hour in a distance, measured from the point at which movement of the service brake pedal or control begins, that is not greater than the distance specified in the table in paragraph (d) of this section.

(b) Upon application of its emergency brake system and with no other brake system applied, a motor vehicle or combination of motor vehicles must, under any condition of loading in which it is found on a public highway, be capable of stopping from 20

miles per hour in a distance, measured from the point at which movement of the emergency brake control begins, that is not greater than the distance specified in the table in paragraph (d) of this section.

(c) Conformity to the stopping-distance requirements of paragraphs (a) and (b) of this section shall be determined under the following conditions:

(1) Any test must be made with the vehicle on a hard surface that is substantially level, dry, smooth, and free of loose material.

(2) The vehicle must be in the center of a 12-foot-wide lane when the test begins and must not deviate from that lane during the test.

(d) Vehicle brake performance table:

Type of motor vehicle	Service brake systems			Emergency brake systems
	Braking force as a percentage of gross vehicle or combination weight	Deceleration in feet per second per second	Application and braking distance in feet from initial speed of 20 m.p.h.	Application and braking distance in feet from initial speed of 20 m.p.h.
A. Passenger-carrying vehicles.				
(1) Vehicles with a seating capacity of 10 persons or less, including driver, and built on a passenger car chassis	65.2	21	20	54
(2) Vehicles with a seating capacity of more than 10 persons, including driver, and built on a passenger car chassis; vehicles built on a truck or bus chassis and having a manufacturer's GVWR of 10,000 pounds or less	52.8	17	25	66
(3) All other passenger-carrying vehicles	43.5	14	35	85
B. Property-carrying vehicles.				
(1) Single unit vehicles having a manufacturer's GVWR of 10,000 pounds or less	52.8	17	25	66
(2) Single unit vehicles having a manufacturer's GVWR of more than 10,000 pounds, except truck tractors. Combinations of a 2-axle towing vehicle and trailer having a GVWR of 3,000 pounds or less. All combinations of 2 or less vehicles in driveway or towaway operation	43.4	14	35	85
(3) All other property-carrying vehicles and combinations of property-carrying vehicles	43.5	14	40	90

NOTE: (a) There is a definite mathematical relationship between the figures in columns 2 and 3. If the decelerations set forth in column 3 are divided by 32.2 feet per second per second, the figures in column 2 will be obtained. (For example, 21 divided by 32.2 equals 65.2 percent.) Column 2 is included in the tabulation because certain brake-testing devices are not available for (b) The decelerations specified in column 3 are an indication of the effectiveness of the basic brakes, and as measured in practical brake testing are the maximum decelerations attained at some time during the stop.

These decelerations as measured in brake tests cannot be used to compute the values in column 4 because the deceleration is not sustained at the same rate over the entire period of the stop. The deceleration increases from zero to a maximum during a period of brake-system application and brake-force buildup. Also, other factors may cause the deceleration to decrease after reaching a maximum. The added distance which results because maximum deceleration is not sustained is included in the figures in column 4 but is not indicated by the usual brake-testing devices for checking deceleration.

(c) The distances in column 4 and the decelerations in column 3 are not directly related. "Brake-system application and braking distance in feet" (column 4) is a definite measure of the overall effectiveness of the braking system, being the distance traveled between the point at which the driver starts to move the braking controls and the point at which the vehicle comes to rest. It includes distance traveled while the brakes are being applied and distance traveled while the brakes are retarding the vehicle.

(d) The distance traveled during the period of brake-system application and brake-force buildup varies with vehicle type, being negligible for many passenger cars and greatest for combinations of commercial vehicles. This fact accounts for the variation from 20 to 40 feet in the values in column 4 for the various classes of vehicles.

(e) The terms "GVWR" and "GVW" refer to the manufacturer's gross vehicle rating and the actual gross vehicle weight, respectively.