

# A Proposed Methodology for the Control of a Semi-Robotic Convoy

by

A. Tommy Economy III

Thesis submitted to the Faculty of the  
Virginia Polytechnic Institute and State University  
in partial fulfillment of the requirements for the degree of

**Master of Science**

in

**Mechanical Engineering**

APPROVED:

*H. H. Robertshaw*

H. H. Robertshaw, Chairman

*C. F. Reinholtz*

C. F. Reinholtz

*R. G. Leonard*

R. G. Leonard

DTIC  
SELECTE  
FEB 19 1991  
S D D

AD-A231 622

DISTRIBUTION STATEMENT A  
Approved for public release;  
Distribution Unlimited

January, 1991  
Blacksburg, Virginia

REPORT DOCUMENTATION PAGE

Form Approved  
GSA No. 0704-0188

Public reporting burden for this collection of information is estimated to average 1 hour per response, including the time for reviewing the data provided, gathering the data, reviewing the collection of information, conducting the review, and summarizing the results. Send comments regarding this burden estimate or any aspect of this collection of information, including suggestions for reducing the burden, to Washington Headquarters Service, Directorate for Information Operations and Reports, 1215 Jefferson Davis Highway, Suite 1204, Arlington, VA 22202-4302, and to the Office of Management and Budget, Paperwork Project, (0704-0188), Washington, DC 20503.

1. AGENCY USE ONLY (Leave blank)	2. REPORT DATE Jan '91	3. REPORT TYPE AND DATES COVERED Master's Thesis Aug '89 - Jan '91
----------------------------------	---------------------------	---

4. TITLE AND SUBTITLE A Proposed Methodology for the Control of a Semi-Robotic Convoy	5. FUNDING NUMBERS
--	--------------------

6. AUTHOR(S) CPT A. Tommy Egojorny III	
---	--

7. PERFORMING ORGANIZATION NAME(S) AND ADDRESS(ES) U.S. Army Student Detachment Ft. Ben Harrison, IN	8. PERFORMING ORGANIZATION REPORT NUMBER
--	--

9. SPONSORING/MONITORING AGENCY NAME(S) AND ADDRESS(ES)	10. SPONSORING/MONITORING AGENCY REPORT NUMBER
---	--

11. SUPPLEMENTARY NOTES
-------------------------

12a. DISTRIBUTION/AVAILABILITY STATEMENT <b>DISTRIBUTION STATEMENT A</b> Approved for public release; Distribution Unlimited	12b. DISTRIBUTION CODE
---	------------------------

13. ABSTRACT (Maximum 200 words) The purpose of this thesis is to develop a generic control law for unmanned-trail vehicles as they follow a lead vehicle. The development of this semi-robotic convoy control law begins with a model of a single vehicle. Two methods are the explored of coupling these into a column. A relationship between the two is derived and the model expanded to "n" vehicles. Utilizing a digital simulation, a three-vehicle convoy is controlled in 1 DOF using state-feedback control theory. The analysis shows this to be an unacceptable method of control due to the steady-state error. Series compensation control is then used to eliminate the error. The system is then expanded into 2 DOF. Using the same series compensator, a 2 DOF simulation is developed. It is shown that the only additional requirement is the trail vehicles must determine their orientation. This is <del>develop</del> accomplish by using a search routine to find the correct position for the lead vehicle's position profile. The simulation verifies the convoy is controlled within the specifications of the system.
--

14. SUBJECT TERMS	15. NUMBER OF PAGES
	16. PRICE CODE

17. SECURITY CLASSIFICATION OF REPORT UNCLASSIFIED	18. SECURITY CLASSIFICATION OF THIS PAGE UNCLASSIFIED	19. SECURITY CLASSIFICATION OF ABSTRACT UNCLASSIFIED	20. LIMITATION OF ABSTRACT
---	--	---	----------------------------

# **A Proposed Methodology for the Control of a Semi-Robotic Convoy**

by

A. Tommy Economy III

Committee Chairman: Harry H. Robertshaw

Mechanical Engineering

## **Abstract**

The purpose of this thesis is to develop a generic control law for unmanned-trail vehicles as they follow a manned lead vehicle. The development of this semi-robotic convoy control law begins with a model of an individual vehicle. Two methods are then explored of coupling these into a model of the column. A relationship between these two methods is derived. The model is then expanded to  $n$  vehicles. Utilizing a digital simulation, a three-vehicle convoy is controlled in one degree-of-freedom (DOF) using pole-placement, state-feedback control theory. The analysis shows this to be an unacceptable method of control due to the steady-state error. The 1 DOF model is then controlled with series compensation. Simulations verify that the steady-state error is eliminated. The system is then expanded into a 2 DOF system. Using the same series compensator, a 2 DOF simulation is developed. It is shown that the only additional requirement of the 2 DOF system is that the trail vehicles need to determine their orientation. This is accomplished by first saving the position and velocity profile of the lead vehicle and then developing a search algorithm to find the appropriate information. The simulation verifies that the convoy is controlled within the specifications of the system.

# Acknowledgements

There are numerous people to whom I owe a great deal of thanks for their assistance. Each one played a vital part in the success of this thesis.

I would like to begin by thanking MAJ Ricky Lynch, U.S. Cavalry, for cultivating my interest in the Army's Robotics Program. Without his encouragement, I'd probably never would have attended Graduate School.

The Army's selection of Virginia Polytechnic Institute and State University provided me with the privilege of meeting and working with Dr. Harry H. Robertshaw, my faculty advisor. His insights and perspectives were extremely helpful as I made the transition from Army officer to graduate student. This thesis could not have been completed without his care and technical guidance.

There were numerous graduate students who spent a great deal of time and provided a great deal of insight. Specifically, Ken Ellis, Buddy Clark, Will Saunders, and Robert Wynn. These guys made seemingly insurmountable problems almost trivial. Thanks.

It would not be complete without thanking the people who kept the world in per-

spective. Steve Shooter, Jim and John Putz, and Mike Beery. Even though none of these guys knows how to play golf, I still never won.

Finally, I must thank my wife and children. I am blessed with a wonderfully understanding wife, Teresa, and two splendid children, JB and Carson. They provide the fulfillment and make everything in my life worthwhile.



APPROVED BY	
DATE	
BY	
DATE	
BY	
DATE	
AI	

Statement "A" per telecon Maj. Jill Whisker. Total Army Personnel Command/TAPC-OPB-D. 200 Stovall. Alexandria, VA 22332-0411  
VHG

2/11/91

# Contents

<b>1</b>	<b>Introduction</b>	<b>1</b>
1.1	Introduction . . . . .	1
1.1.1	The Basic Convoy Concept . . . . .	2
1.1.2	The Semi-Robotic Convoy . . . . .	4
1.1.3	Objectives of This Thesis . . . . .	7
1.2	Outline of Thesis Work . . . . .	7
1.3	Literature Review . . . . .	10
1.3.1	Lateral and Longitudinal Vehicle Controllers . . . . .	10
1.3.2	Vehicle-Tracking Control Systems . . . . .	12
1.3.3	Position/Navigation Systems . . . . .	15
1.3.4	Summary . . . . .	17
<b>2</b>	<b>Development of One Degree-of-Freedom Model</b>	<b>18</b>
2.1	Introduction . . . . .	18
2.2	Equation of Motion for a Single Vehicle . . . . .	19
2.3	Two Approaches to Model the Column . . . . .	23
2.3.1	Leader-Follower (L-F) Approach . . . . .	23
2.3.2	Follower-Follower (F-F) Approach . . . . .	24
2.3.3	Comparison of the Two Approaches . . . . .	25

2.3.4	Model of an n-Vehicle Column . . . . .	28
2.4	Example . . . . .	28
2.4.1	Developing the Model Parameters . . . . .	29
2.4.2	Model of the Column . . . . .	30
2.5	Summary . . . . .	30
<b>3</b>	<b>Developing a Difference Equation for the Convoy</b>	<b>31</b>
3.1	Introduction . . . . .	31
3.2	Digital Systems . . . . .	31
3.2.1	Discussion of Sampled-Data Systems . . . . .	32
3.2.2	The Relationship Between Differential and Difference Equations	34
3.3	Selection of the Sampling Period . . . . .	35
3.3.1	Ackermann's Rule of Thumb . . . . .	36
3.3.2	Another Approach for Selecting the Sampling Interval . . . . .	36
3.4	Digitizing the Model of the Column . . . . .	37
3.4.1	Digitizing the n-Vehicle Column . . . . .	37
3.4.2	Digitizing the Three-Vehicle Column Example . . . . .	38
3.5	Discussion of the Digital Simulation . . . . .	40
3.6	Summary . . . . .	41
<b>4</b>	<b>Developing and Simulating a State Feedback Control Law</b>	<b>42</b>
4.1	Introduction . . . . .	42
4.2	Controllability . . . . .	42
4.3	State Feedback Control Theory . . . . .	44
4.3.1	Application of the State Feedback Control . . . . .	45
4.3.2	Impact of State Feedback on System Performance . . . . .	46

4.4	Selecting State Feedback Gain Sets . . . . .	51
4.4.1	Pole-Placement . . . . .	51
4.4.2	Conclusions . . . . .	57
4.5	Summary . . . . .	60
<b>5</b>	<b>Eliminating Error With a Series Compensator</b>	<b>61</b>
5.1	Introduction . . . . .	61
5.2	Analysis of the Steady-State Error . . . . .	61
5.3	Series Compensation Theory . . . . .	63
5.4	Applying a Series Compensator to the Semi-Robotic Convoy . . . . .	65
5.5	Series Compensation of the Column . . . . .	67
5.5.1	The Three-Vehicle Column . . . . .	67
5.5.2	Simulations of the Three-Vehicle Column . . . . .	68
5.5.3	The n-Vehicle Column . . . . .	70
5.6	Summary . . . . .	74
<b>6</b>	<b>Solving the Two Degree-of-Freedom Problem</b>	<b>76</b>
6.1	Introduction . . . . .	76
6.2	Problem Definition . . . . .	77
6.2.1	Defining the Two Degrees-of-Freedom . . . . .	77
6.2.2	Comparison of the 1 and 2 DOF Problems . . . . .	78
6.2.3	Additional Requirements of the 2 DOF System . . . . .	79
6.3	Solving the 2 DOF Problem . . . . .	80
6.3.1	Developing a Search Algorithm for the Trail Vehicle . . . . .	81
6.4	Simulation of the 2 DOF System . . . . .	84
6.5	2 DOF Solution for n-Vehicles . . . . .	88



6.6 Summary . . . . .	90
<b>7 Conclusions and Recommendations</b>	<b>91</b>
7.1 Conclusions . . . . .	91
7.2 Recommendations . . . . .	93
<b>List Of References</b>	<b>94</b>

# List of Figures

2.1	Free Body Diagram . . . . .	20
3.1	Sampled Data System . . . . .	33
4.1	Block Diagram of State Feedback Control for One Vehicle . . . . .	47
4.2	Derivation of the Closed-Loop Error Transfer Function . . . . .	48
4.3	Simulation of Ramp Input for Position with $\zeta=.45$ . . . . .	55
4.4	Simulation of Ramp Input for Position with $\zeta=1.3$ . . . . .	58
4.5	Simulation of Ramp Input for Position with $\zeta=1.0$ . . . . .	59
5.1	Simple Control Loop with a Series Compensator . . . . .	64
5.2	State Space Depiction of the Plant with Compensator . . . . .	69
5.3	Series Compensation with $\zeta = 1.0$ . . . . .	71
5.4	Series Compensation with $\zeta = 1.3$ . . . . .	72
5.5	Series Compensation with $\zeta = 1.5$ . . . . .	73
5.6	Series Compensation of n-Vehicles . . . . .	75
6.1	Flow Chart of Search Routine . . . . .	83
6.2	2 DOF Simulation with Variable Angle and Constant Velocity . . . . .	85
6.3	2 DOF Simulation with both Variable Angles and Velocities . . . . .	86

6.4	2 DOF Simulation with Variable Velocities and Dramatic Variations of Angles . . . . .	87
6.5	2 DOF Simulation with Variable Velocities and Dramatic Variations of Angles . . . . .	89

# List of Tables

2.1	Simulated Coefficients of Modeled Vehicles . . . . .	30
4.1	Comparison of Desired Characteristic Equations . . . . .	56

# Chapter 1

## Introduction

### 1.1 Introduction

The decreasing defense budget has forced the military to examine ways to maintain the present level of preparedness with fewer soldiers and fewer dollars. Consequently, the military has increased its research efforts in the area of robotics. Robotics offers the ability to reduce the number of personnel required to accomplish a specific task. If the task to be accomplished is in an area exposed to hostile fire, robotics offers the additional benefit of reducing the number of potential casualties.

Robotics is normally associated with a mechanical manipulator. While this is the emphasis in industrial applications, military applications, however, have a much larger scope. Robotics in the military encompasses the automation of any aspect of human performance as a robotic technology. This automation technology is being examined in the areas of tele-operated vehicles, remotely piloted drones, and autonomous vehicles. One particular application that has a near-term application is that of a semi-autonomous column of vehicles, or a semi-robotic convoy.

A semi-robotic convoy has two aspects which are attractive for military application.

The first is that the lead vehicle of the column is operated by a human operator. The tasks of planning the route, controlling the speed, and avoiding obstacles can be handled by the operator. This considerably reduces the expense because the automation of path planning and obstacle avoidance is computationally intensive and requires very accurate maps and expensive sensors. The second attractive aspect is the trail vehicles are unmanned. This reduces the number of personnel required. One or two operators can move a column of vehicles where before it would require at least one driver per vehicle.

### **1.1.1 The Basic Convoy Concept**

Throughout history, armies have utilized convoys of different types to move from one location to another. Military convoys are used to move units to and from the battlefield as well as moving to different locations on the battlefield. They are utilized whenever the requirement for speed of movement outweighs the requirement for security. The advantage of a convoy is that it allows a commander to quickly move forces while still maintaining the necessary command and control of his forces. In today's heavy forces, like the US Army's Armor and Mechanized Infantry units, convoys are a vital part of the three basic missions: Move, Attack, and Defend.

Military convoys operate accordance with the Army's tactical doctrine which is outlined in (FM 7-7J, 1986). This doctrine is summarized below. The route of movement is specified, in addition to control measures, to assist in the control of the convoy. These control measures include a starting point (SP) at the beginning of the route, check points (CP) at identifiable points along the route, and a release

point (RP) at the end of the route. The vehicles travel single file at a specified speed and interval. Two speeds are given. The first speed is the speed the convoy will be travelling. The second speed is called the catch-up speed. This is the maximum speed a vehicle can travel when trying to close a gap in the column (this precludes the accordion effect of vehicles getting spread out and then bunched up). Based on the number of vehicles in the convoy, the speed of the convoy, and the interval between vehicles, the convoy planner determines the amount of time it will take the convoy to pass any given point, called Pass Time. The convoy planner specifies the time that both the lead vehicle and the trail vehicle should pass each control measure. With this information, the convoy planner can coordinate the movement of numerous convoys over the same route avoiding any interference of one convoy on another convoy.

From this description of convoys, I derived four criteria which are necessary for any successful convoy. They are listed below in what I believe is their correct order of priority.

1. Each of the trailing vehicles should follow the same path as the lead vehicle. If the lead vehicle avoids an obstacle, then the trailing vehicles should avoid the obstacle in the same manner. Ideally, the center line of the trailing vehicle will follow the same centerline as the lead vehicle.
2. There are two different metrics which need to be maintained. The first is the distance between adjacent vehicles (interval) and the second is the distance between the first and last vehicle (convoy length).

3. The convoy must be at the proper speed, interval, and convoy length when the lead vehicle reaches the SP. Both the interval and the convoy length need to be maintained throughout the movement.
  
4. The speed the column will travel and the interval between vehicles needs to be selected very carefully. The decision on the speed should factor in how fast the slowest vehicle can safely travel the route. The decision on the interval distance is based both on the speed of the column and on the visibility at the time of the movement, since the driver needs to be able to see the vehicle in front.

### **1.1.2 The Semi-Robotic Convoy**

Conceptually, the semi-robotic convoy operates in the same manner as the basic convoy outlined above. There are, however, some differences which need to be addressed. In the semi-robotic convoy, the operator of the lead vehicle essentially becomes the convoy planner. He determines the appropriate interval between the vehicles and which vehicle goes where in the column. As in the manned convoy, the operator must then drive the prescribed route in a manner which facilitates other vehicles following at a constant distance. Rapid accelerations and decelerations make maintaining a constant interval extremely difficult. Based on the movement of the lead vehicle, each trailing vehicle calculates the necessary force on either the brake or accelerator pedal and the desired angle of the steering wheel. The trailing vehicles then move so they follow the path of the lead vehicle while maintaining the interval between the adjacent vehicles.



The end result of the two columns is the same; an orderly march at a specified speed, interval, and column length. To be feasible, the semi-robotic convoy must perform as well as its manned counterpart. Therefore, it must meet the same criteria of success. Unfortunately, the previously described criteria were written to describe success in general. They are not detailed enough for use for the specifications for a semi-robotic system. Based on my eight years of experience with military convoys, I translated these criteria into system specifications for a semi-robotic convoy.

1. The latitudinal accuracy requirement for the convoy is based on the centerline of the vehicles. The centerline of the trail vehicle should never move more than six inches on either side of the centerline of the lead vehicle when the lead vehicle was at that particular point. If the lead and trail vehicles are of the same type, the wheels or tracks of the trail vehicle should be within twelve inches of the wheels or tracks of the lead vehicle. This is a stringent requirement, but absolutely necessary. If the lead vehicle follows a breached path through a minefield, the trail vehicles must follow that same path. Anything else is unacceptable.
  
2. The longitudinal accuracy requirements has two different specifications.
  - (a) The steady-state interval, or distance between adjacent vehicles, must be within 5% of the specified interval.
  
  - (b) The column length, or distance between the first and last vehicle, must

remain within 10% of the column length specified. This distance can be calculated by multiplying the interval times one less than the number of vehicles.

$$\text{Column Length} = \text{Interval} \times (\text{Number of Vehicles} - 1)$$

3. The system must not use excessive control to control the convoy. The military is very conscientious of fuel efficiency, and as such it is not acceptable to have frequent or dramatic accelerations or decelerations.
4. The system must respond fast enough so that steady-state is achieved as quickly as possible. A settling time of 5 seconds is sufficient to meet this requirement.
5. With such a small settling time and such large vehicle masses, the dynamic response of the system is not a critical concern. What is a critical concern is that collisions are to be avoided at all times. Therefore, the only dynamic specification is that the interval between vehicles cannot vary more than 20% of the specified interval during the transient response of the system.
6. The column must be capable of accommodating different intervals between vehicles based on the determination of the operator of the lead vehicle.

### 1.1.3 Objectives of This Thesis

The major objective of this thesis is to develop a methodology by which this semi-robotic convoy concept is applicable to a host of different vehicles. This objective can be broken down into three different goals. First, we want to have thorough understanding of the vehicle model. Since these vehicles are the building blocks of the column, it is necessary to completely understand their operation. Second, we need to understand what is necessary to ensure that the individual vehicles maintain their proper place in the column while keeping the correct interval with respect to the other vehicles. Finally, we want to understand how these relative positions in the column can be maintained as the vehicles travel an arbitrary path. In obtaining these three goals, the major objective of the thesis is also achieved.

## 1.2 Outline of Thesis Work

This thesis is organized to systematically analyze each of the the goals described above. As each goal is achieved, a simulation is developed to verify the findings. The end result is a methodology for the control of a semi-robotic convoy which can be applied to n-vehicles. A detailed description of this systematic analysis is outlined below.

This thesis begins with a thorough examination of the single vehicle. Utilizing some simplifying assumptions, a generic model is developed using Newton's Second Law. This generic vehicle model is then specifically applied to two different vehicles: the Army's M1 Abrams Main Battle Tank (M1) and the High-Mobility Multi-Purpose Wheeled Vehicle (HMMWV). The masses of these vehicles are known. The other

coefficients of the model are selected so that the acceleration profile and maximum velocity of the model in simulation matched the acceleration profile and maximum velocity of the real vehicle. The result is a second-order model that has the same performance characteristics as the actual vehicle.

Next, we examine how these vehicle models can be tied together into a one degree-of-freedom (1 DOF) column. Two approaches are analyzed. The first is called the Leader-Follower (L-F) approach. This approach measures the states, position and velocity, of the trail vehicles in the column in absolute terms (x,y position). The second approach is called Follower-Follower (F-F). Here the position and velocity of the trail vehicles are measured with respect to the vehicle immediately in front of it in the column. The purpose of the two approaches is to incorporate the different types of information supplied by various types of sensors. A relationship is then developed between the two approaches which ensures that any further work is applicable to any system utilizing a wide variety of sensors. With this relationship, the model is expanded to incorporate n-vehicles.

This 1 DOF model is then applied to an actual convoy. This n-vehicle model is then modified to a three-vehicle column for the purpose of analysis. We selected a three-vehicle column because it is the smallest model which allows analysis of dynamics between adjacent trailing vehicles. After a brief discussion of sampled data systems, a digital simulation of the convoy is developed. This simulation is the basis for all future analysis.

The analysis of the control law to control the column comes next. We examine

the controllability of the system. After determining that both the continuous and sampled-data systems can be controlled, state-feedback control theory is explained and then applied to the system. After conducting several simulations, an assesment is made of the feasibility of using this type of control on generic semi-robotic convoys.

The desire to alleviate the steady-state error leads to the examination of control using a series compensation. The theory of series compensation is first explained and then applied to the model. The simulation verifies that this compensation eliminates the steady-state error while providing adequate control of the 1 DOF system.

The final task is to expand the initial 1 DOF system to a more realistic 2 DOF system. The 2 DOF system is thoroughly analyzed and it is determined that the only additional requirement of the 2 DOF system is that the trail vehicle needs to be able to determine a location on the path travelled by the lead vehicle which is the appropriate interval length behind the lead vehicles current location. This is completed in three steps. First, the position and velocity profile of the lead vehicle is saved in memory and made available to the trail vehicle. Second a search algorithm allows each trail vehicle to determine the correct data from the lead vehicle's position and velocity profile. Third, the correct angle of the trail vehicle is calculated from the available data. The simulations of the system verify that this method of control meets all the specifications outlined for the performance of the semi-robotic convoy. This thesis concludes with conclusions and recommendations.

## **1.3 Literature Review**

This review of current literature will be separated into three different sections. The first section will examine published material in the area of either lateral and longitudinal control of vehicles. The second section will examine the efforts which combine both longitudinal and lateral control into a vehicle-tracking control system. The final section will examine the accuracy of three different position/navigation systems.

The work in this thesis deals extensively with basic concepts in control theory. This review will not examine the texts which include these concepts. These works will be cited in the body of the thesis when the specific ideas are discussed.

### **1.3.1 Lateral and Longitudinal Vehicle Controllers**

During the late 60's and early 70's, there was a great interest in developing an automated highway system. The goal was to use computer control to obtain optimal vehicle flow along a particular roadway. (Pletta, 1987). The related lateral and longitudinal controllers, discussed below, were all developed with this system in mind.

#### **Lateral Control of Vehicles**

There are two basic technologies for the control of lateral errors which have been examined. Both of these technologies use vehicle mounted sensors in conjunction with a pre-prepared path. The first technology is the inductively coupled guide wire. This technology operates on the concept that the conductor wire, excited by a current, will emit a magnetic field. The strength of the magnetic field is proportional

to the distance from the sensor to the wire. This field then induces a voltage in the pickup coil located on the vehicle. This induced voltage is then used as an error signal. Both one- and two-wire systems have been explored. The single wire system (Cromier, 1980) resulted in tracking errors of less than 10 cm while tracking a 100 m radius curve at 40 mph. While tracking a straight line, the error was less than 4 cm. While tracking a straight line, the two wire system (Olson, 1969) resulted in a lateral error of just over 1 cm for speeds up to 70 mph. While tracking a 76 m radius curve at 70 mph, the system produced errors of up to 6 cm. It should be noted that both these tests were conducted on unreinforced roads. During early testing, the steel mesh of the reinforced road distorted the error signal, which severely degraded the performance of the system.

The second technology for lateral control is the two-frequency radar (Mayhan, 1982). This technology uses a two-frequency radar to sense the distance to a foil-covered wall along the road. The phase difference between the transmitted and received signals is converted to a distance measurement. The errors produced for this system were of the same magnitude of the single conducting wire.

### **Longitudinal Control of Vehicles**

There has been numerous efforts in the area of longitudinal control of vehicles. Pappard and Gourishankar (1972) developed an optimal controller for a variety of cost functions. Using a simplified second-order model of two identical vehicles, they developed a closed-loop state feedback model. The feedback gains were determined based on weighting factors of position, velocity, and the magnitude of the input. By

varying the weighting factors, they calculated the appropriate input for the vehicle. The simulation of a six-vehicle system on an analog computer verified that an optimal solution could indeed be derived producing acceptable results.

Proportional control was used by R.J. Caudill, P. Di Matteo, and S.P. Thomas (1982). In this effort, a comprehensive model of the vehicle was developed, including a model of the engine, torque converter, and automatic transmission. The proportional controller was only applied to the feedback of velocity. The appropriate gain was determined from a computer simulation of the system. The simulations of this controller included both a string of five identical vehicles and a string of five different vehicles. The results of the simulation indicated that it was feasible to operate both strings in an efficient and safe manner.

### **1.3.2 Vehicle-Tracking Control Systems**

A logical progression from lateral and longitudinal control of vehicles is the development of a system to control both aspects of vehicle movement. The initial thrust of this research was to develop completely autonomous vehicles. While there is still a great deal of interest in this technology, it is extremely complex and only has long-term applications. A subset of this effort, with near term applications, is the vehicle-tracking capability. There have been several efforts with this goal as the objective.

The Ground Surveillance Robot (GSR) was designed as a completely autonomous vehicle (Harmon, 1987). One of the first tasks incorporated into the system was



the ability to follow a target vehicle. The system used an array of seven Polaroid ranging sensors to track the target vehicle. The sensors had a maximum range of 10 m and a resolution of .17 m. The array consisted of three fixed and four steerable sensors. In 1985, the GSR successfully tracked the target vehicle at a distance of 12 feet and at a speed of 10 mph (Pletta, 1987). No further information on the accuracy of the performance was available, nor was any other information available about the current status of the program.

In 1981, IBM tested a Drone Formation Control System on a column of 11 M47 Patton Main Battle Tanks. The system was originally designed to control formations of aircraft drones, but in 1980 the Army requested the capability be applied to a column of tanks for use as target vehicles. The system is based on position and velocity information obtained from small, unmanned Interrogator Subsystems located on the boundaries of the area of operation. Although capable of being controlled by a remote operator, the system normally operates on a pre-planned path consisting of a series of curved and straight line segments. It is controlled by a central IBM mainframe computer. The tests of the system resulted in interval errors of  $\pm 30$  feet and lateral errors of  $\pm 15$  feet (Gray, 1983).

The Sandia National Laboratories funded a feasibility study for an Attachable Robotic Convoy (ARCC) System (Pletta, 1987). The ARCC would have a driver in the lead vehicle and no more than two people to operate five vehicles. The mechanism for determining the path was stressed as the key to the system. This study examined two methods of path determination for the trail vehicles. In the first method, each of the following vehicles measures the relative distance and angle to

the preceding vehicle. In the second method, the followers sense the path independently of the other vehicles but still must sense the distance to the preceding vehicle control of the interval. A detailed review of available sensors was also presented. The conclusion was that the current sensors were not sufficient to allow operation on public roadways, but they were sufficient for limited military applications.

Kaman Sciences Corporation developed a vehicle control system for remote control target vehicles that can easily be adapted to a semi-robotic convoy (Stokes,1989). The "learn by doing" concept is based on a Radio Frequency Navigational Grid which provides an accurate position for each vehicle. By measuring and recording time intervals between successive position samples of the lead vehicle, the velocity information is obtained. With this information, the trailing vehicles can repeat the learned path precisely. The semi-robotic convoy application is simply a time compression problem. As the lead vehicle travels the desired path, the position and velocity information is relayed to the trailing vehicles. The trailing vehicles then follow this learned path. The current system allows vehicle operation at speeds in excess of 30 mph (48 kph) over paths up to 15 km long and produces a lateral error of less than 1 meter.

In 1989, the US Army funded a requirement for a semi-robotic convoy. The program, called Training Wheels, called for the single vehicle path retrace concept that will allow a company-size column, 10-15 vehicles, to be operated and controlled by two personnel. The column would be utilized as a training device, simulating a column of threat vehicles at the National Training Center at Fort Irwin, California. This would allow expansion of the existing Opposing Force to a Division sized element

without a significant manpower increase. (Draft - Robotics Master Plan, 1989).

### 1.3.3 Position/Navigation Systems

A fundamental aspect of the semi-robotic convoy system proposed in this thesis is the ability for a vehicle to determine its position. There are numerous systems and technologies available to determine absolute position for all types of vehicles. The purpose of this section is show the accuracy available with current systems and to determine if it is feasible to assume that each vehicle of a semi-robotic convoy accurately knows its own position.

The oldest, and most widely used is the LORAN system. LORAN, which stands for long range navigation, was first used during World War II. LORAN-C, the current version of the system, is a hyperbolic radio navigation system which provides accurate long range navigation. The system is designed so the receiving vehicle measures the difference of arrival times of radio signals from two synchronized transmitters. This provides an accurate distance difference between the paths of the radio waves. The locus of points with this constant distance between the two transmitters is a hyperbola. This same process is repeated with a different pair of transmitters. The intersection of the two hyperbolas determines the vehicle location (O'Halloran, 1980). The system is capable of producing accurate positions on the order of 10 to 15 yards (Fuentes,1986).

One of the newest technologies is the Navstar Global Positioning System (GPS). This is a satellite-based radio navigation system which will provide accurate po-

sition and timing information anywhere on or near earth. The initial system will consist of 21 satellites. The satellites will transmit a synchronized signal. The GPS receiver receives this signal from four different satellites. The receiver then solves four equations and four unknowns. Three of the unknowns are for position and the fourth unknown is time, to synchronize the receiver's clock with that of the transmitters (Parkinson, 1983). The system can produce accurate positions within 6 m (Ananda, 1990).

The final positioning system to be discussed is the Radio Frequency Navigational Grid (RFNG) developed by Kaman Sciences Corporation. Unlike the previous two systems, this will provide accurate positions only over a relatively small area, approximately 15 square kilometers. This system, like LORAN-C, uses a synchronized radio transmission to determine the positions. Instead of measuring the time difference between the two radio signals, RFNG measures the phase difference between the signal from three portable transmitters: a common station and two other transmitters. This produces precise two-dimensional, hyperbolic position with a resolution of approximately 1.5 inches (Stokes, 1989).

These three systems are only a sampling of the technologies available for position determination. LORAN-C and GPS were both designed for the purpose of long range position determination. The accuracy of these two systems do not lend themselves to the application with a semi-robotic convoy. The Radio Frequency Navigational Grid provides excellent position determination over a much smaller area. The accuracy of this system suggests that it is indeed feasible to assume that each vehicle of the semi-robotic convoy accurately knows its own position.

#### 1.3.4 Summary

A review of the available literature showed the earlier efforts of lateral and longitudinal control provided a great deal of information available about both the model of the individual vehicle and the type of control law utilized. The later efforts, which combined these two aspects of control, provided very little information about either the model or the type of control. With the knowledge that accurate position information is available, this thesis attempts to fill this void by developing both a model for the convoy and a two dimensional control law for the control of a semi-robotic convoy.

## Chapter 2

# Development of One Degree-of-Freedom Model

### 2.1 Introduction

The development of a model is one of the most important aspects of any engineering effort. The model provides a basis for all calculations and hence the derived conclusions are tied to the model and its limitations. The challenge is to develop a model which is simple enough to be analyzed but is still adequate to represent the performance of the system. For the initial model, we chose a one degree-of-freedom (1 DOF) system. This model is simple enough to be easily analyzed while still representing all the dynamics involved with the interval maintenance within the column.

This chapter begins with a derivation of the vehicle model. We then discuss the two possible approaches to modeling a convoy. The mathematical model is derived for each method. The two approaches are then compared and a relationship between the two is developed. The chapter concludes by developing a model of a real convoy consisting of three US Army vehicles.

## 2.2 Equation of Motion for a Single Vehicle

A semi-robotic convoy is simply a column of single vehicles. To derive a mathematical model of the convoy, we first modeled the individual vehicle using Newton's Second Law,  $\sum F=ma$ . Figure 2.1 shows that there are two opposing forces being applied to each vehicle. The first is the force that propels the vehicle,  $F_i$ , which is the force applied from the tires to the road surface, and the second force is a drag force,  $c_i\dot{x}_i$ , which resists the motion of the vehicle. There are numerous other forces in the actual vehicle. To make this 1 DOF model realistic, each of these other forces needs to be included into one of the three coefficients in the linear Newtonian model: the mass, the damping coefficient, or the force.

There are eight generic forces present in any vehicle (United States Military Academy, 1977). These forces can be broken down into forces in the engine and forces on the vehicle. The forces will be addressed and categorized as to whether it promotes or resists the movement of the vehicle.

1. The forces in the engine are gas pressure forces, inertia forces of rotating masses, inertia forces of reciprocating masses, and centrifugal forces of rotating masses. The gas pressure forces and the centrifugal forces are the only ones which contribute purely to the propulsion of the vehicle. These are the forces which drive the piston and keep the engine turning when no other force is applied. The inertia forces are retarding forces in terms of resisting accelerations, but they are contributing forces in terms of maintaining a constant velocity.

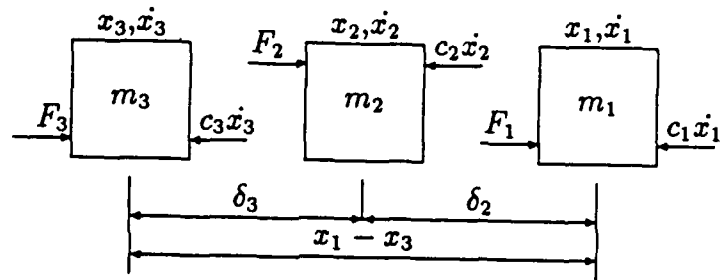

Figure 2.1: Free Body Diagram



2. The forces which act on the vehicles are all forces which normally resist the movement of the vehicle. The air resistance force of the wind on the body of the vehicle, the rolling resistance force of the tires on the road surface, and the force due to gravity all resist the movement of the vehicle. The force of gravity can work to propel the vehicle if the vehicle is headed downhill. If not, this force either is negligible or works to retard the movement of the vehicle.

It is necessary to note, there are significant non-linearities in these forces. For example, the gas pressure forces in the engine produce a non-linear force at the tires. The force at the tires is a function of both the gas pressure force and the gear ratio of the transmission. A certain level of gas pressure in first gear results in a higher force at the tires than the same pressure in second gear. Therefore, these non-linearities need to be addressed.

By making the following assumptions, each of the eight forces described above can be included in either the propulsion force,  $F_i$ , or the drag coefficient,  $c_d$ .

1. The forces on the vehicle only deal with motion in one direction, the direction of travel. There are no forces considered which impact on the second dimension of the model, which is perpendicular to the direction of travel.
2. All forces have been assumed to be linear.
3. The damping forces in the engine and vehicle expressed above have been included into one coefficient and that coefficient is assumed to be constant.

The resulting equation for a single vehicle is:

$$\ddot{x}_i = \frac{F_i}{m_i} - \frac{c_i}{m_i} \dot{x}_i \quad (2.1)$$

where:

- $c_i$  - is the damping coefficient of the  $i$ th vehicle
- $F_i$  - is the input or propulsion force of the vehicle
- $m_i$  - is the mass of the vehicle

Equation 2.1 can also be expressed as a series of two linear differential equations.

Since this notation will be used throughout this thesis, it is included below:

$$\begin{bmatrix} \dot{x} \\ \ddot{x} \end{bmatrix} = \begin{bmatrix} 0 & 1 \\ 0 & \frac{-c}{m} \end{bmatrix} \begin{bmatrix} x \\ \dot{x} \end{bmatrix} + \begin{bmatrix} 0 \\ \frac{1}{m} \end{bmatrix} u \quad (2.2)$$

or

$$\dot{\mathbf{x}} = \mathbf{F} \mathbf{x} + \mathbf{g} u \quad (2.3)$$

where:

- $\mathbf{F}$  - is a  $2 \times 2$  matrix
- $\mathbf{x}$  - is a state vector of position and velocity
- $\mathbf{g}$  - is a  $2 \times 1$  vector
- $u$  - is a scalar input,  $F$ , to the system

With the model of a single vehicle in hand, it is now necessary to discuss how these single-vehicle models can be tied together. Two approaches are discussed in the next section.

## 2.3 Two Approaches to the Model of the Column

The objective of this section is to develop a model for a semi-robotic convoy. To accomplish this, we will first derive a model for a three-vehicle column. The size of this model will facilitate the discussion with a model of manageable size. The section will conclude as we generalize this model into an n-vehicle column.

Equation 2.2 shows there are two states required to describe a single vehicle: position and velocity. It follows that a model of a three-vehicle column will have six states: the position and velocity of each vehicle. The states of the trailing vehicles are dependent on the frame of reference selected to describe the position of the trailing vehicles. This frame of reference is a function of the type of sensor used and the information it provides. There are two different frames of reference which can be utilized to define these states. The first, which we call the Leader-Follower (L-F), models the column using the distance between the lead vehicle and the trailing vehicles as a reference. The second approach, called Follower-Follower (F-F), models the column using the distance between successive vehicles as a reference. The basic difference between these two is that in the L-F approach, the states of the trail vehicles are the absolute positions and velocities of the vehicle, and in the F-F approach, the states of the trail vehicles are relative to the preceding vehicle. These two different approaches are discussed below.

### 2.3.1 Leader-Follower (L-F) Approach

The L-F approach to modeling uses the absolute x,y position of each vehicle as a frame of reference. Take for example the three-vehicle column shown in Figure 2.1.

The position of the second vehicle is  $x_2$ , the velocity of the vehicle is  $\dot{x}_2$ , and the position and velocity of the third vehicle are  $x_3$  and  $\dot{x}_3$ . These states are independent of any other vehicle in the column. The resulting model of the column is:

$$\begin{bmatrix} \dot{x}_1 \\ \ddot{x}_1 \\ \dot{x}_2 \\ \ddot{x}_2 \\ \dot{x}_3 \\ \ddot{x}_3 \end{bmatrix} = \begin{bmatrix} 0 & 1 & 0 & 0 & 0 & 0 \\ 0 & \frac{-c_1}{m_1} & 0 & 0 & 0 & 0 \\ 0 & 0 & 0 & 1 & 0 & 0 \\ 0 & 0 & 0 & \frac{-c_2}{m_2} & 0 & 0 \\ 0 & 0 & 0 & 0 & 0 & 1 \\ 0 & 0 & 0 & 0 & 0 & \frac{-c_3}{m_3} \end{bmatrix} \begin{bmatrix} x_1 \\ \dot{x}_1 \\ x_2 \\ \dot{x}_2 \\ x_3 \\ \dot{x}_3 \end{bmatrix} + \begin{bmatrix} 0 & 0 & 0 \\ \frac{1}{m_1} & 0 & 0 \\ 0 & 0 & 0 \\ 0 & \frac{1}{m_2} & 0 \\ 0 & 0 & 0 \\ 0 & 0 & \frac{1}{m_3} \end{bmatrix} \begin{bmatrix} u_1 \\ u_2 \\ u_3 \end{bmatrix} \quad (2.4)$$

where:

- $x_1$  &  $\dot{x}_1$  are the states of the lead vehicle
- $x_2$  &  $\dot{x}_2$  are the states of the second vehicle
- $x_3$  &  $\dot{x}_3$  are the states of the third vehicle
- $u_i$  is the input to the  $i$ th vehicle

### 2.3.2 Follower-Follower (F-F) Approach

The F-F approach differs from the L-F approach in that it defines the states of the trailing vehicles in terms of the difference between its position and the position of the vehicle immediately in front of it. Using Figure 2.1, the position of the second vehicle,  $\delta_2$ , is  $x_1 - x_2$  and the position for the third vehicle,  $\delta_3$ , is  $x_2 - x_3$ . The states of the trailing vehicles are strictly a function of the trailing vehicles relative position to the vehicle in front of it. The resulting model is:

$$\begin{bmatrix} \dot{x}_1 \\ \ddot{x}_1 \\ \dot{\delta}_1 \\ \ddot{\delta}_1 \\ \dot{\delta}_2 \\ \ddot{\delta}_2 \end{bmatrix} = \begin{bmatrix} 0 & 1 & 0 & 0 & 0 & 0 \\ 0 & \frac{-c_1}{m_1} & 0 & 0 & 0 & 0 \\ 0 & 1 & 0 & -1 & 0 & 0 \\ 0 & \frac{-c_1}{m_1} & 0 & \frac{c_2}{m_2} & 0 & 0 \\ 0 & 0 & 0 & 1 & 0 & -1 \\ 0 & 0 & 0 & \frac{-c_2}{m_2} & 0 & \frac{c_3}{m_3} \end{bmatrix} \begin{bmatrix} x_1 \\ \dot{x}_1 \\ \delta_1 \\ \dot{\delta}_1 \\ \delta_2 \\ \dot{\delta}_2 \end{bmatrix} + \begin{bmatrix} 0 & 0 & 0 \\ \frac{1}{m_1} & 0 & 0 \\ 0 & 0 & 0 \\ 0 & \frac{1}{m_2} & 0 \\ 0 & 0 & 0 \\ 0 & 0 & \frac{1}{m_3} \end{bmatrix} \begin{bmatrix} u_1 \\ u_2 \\ u_3 \end{bmatrix} \quad (2.5)$$

where:

$x_1$  &  $\dot{x}_1$  are the states of the lead vehicle  
 $\delta_1$  &  $\dot{\delta}_1$  are the states of the second vehicle  
 $\delta_2$  &  $\dot{\delta}_2$  are the states of the third vehicle  
 $u_i$  is the input to the  $i$ th vehicle

### 2.3.3 Comparison of the Two Approaches

These two approaches were outlined because each is an acceptable way of describing the states of the convoy. We now want to look at these two approaches in terms of equipment and sensors required. It is important to understand the impact of these sensors, because these sensors provide the necessary navigational information that is available. Since, the purpose of this study is to develop a descriptive model for all semi-robotic convoys, a relationship will be developed between these two approaches. With this relationship, the approaches become interchangeable. This will allow us to select one approach to use in future analysis without a loss of generality.

#### Equipment and Sensors Required

To implement the L-F approach, there are two requirements for equipment. First, the absolute position and velocity for each vehicle must be determined. This requires an on-board navigation device to sense the absolute position of each vehicle. The velocity of each vehicle can be found by two possible methods. It can either be calculated from the change in position over a given time or it can be determined by a sensor located on the vehicle. The second requirement for equipment is that this position and velocity information needs to be communicated with other vehicles in the column. Since, it would not be acceptable to have a hard-wire link between the vehicles, this information must be transmitted between vehicles. This requires a transmitter and receiver. These devices must have sufficient bandwidth to carry

the necessary information.

There are three pieces of information which must be sensed to implement a F-F model. The first two pieces of information needed are the interval between each vehicle and the preceding vehicle and how fast that interval is changing. The third piece of required information is that each vehicle must sense the orientation of the preceding vehicle. Since the semi-robotic convoy will need to operate in all types of environments, care must be made in the selection of these sensors. Take for example a column operating in a desert environment with a substantial amount of dust. The sensors must be able to determine the required information through a very thick obscurant. Additionally, if the sensor is an active sensor which emits a signal, the signal needs to be such that detection by enemy is unlikely.

### **Relationship Between Approaches**

In an examination between the two approaches, it is important to note that the difference between the two is really a function of the type of sensors employed to determine the states of the vehicles. If a sensor determines the absolute position of the vehicle, the L-F approach is used. If the sensors finds the relative position to the vehicle ahead, the F-F approach is appropriate.

Both the L-F and the F-F approach use the absolute position to determine the states of the lead vehicle. The F-F description of the states of the trail vehicles,  $\delta$ , is also a function of the absolute position of the trail vehicles. For example,  $\delta_2 = x_1 - x_2$ . Is there a transformation matrix which will change the states from one description to another?

The following matrix will shift the states from the L-F description of the convoy to the F-F description.

$$\begin{bmatrix} x_1 \\ \dot{x}_1 \\ x_1 - x_2 \\ \dot{x}_1 - \dot{x}_2 \\ x_2 - x_3 \\ \dot{x}_2 - \dot{x}_3 \end{bmatrix} = \begin{bmatrix} 1 & 0 & 0 & 0 & 0 & 0 \\ 0 & 1 & 0 & 0 & 0 & 0 \\ 1 & 0 & -1 & 0 & 0 & 0 \\ 0 & 1 & 0 & -1 & 0 & 0 \\ 0 & 0 & 1 & 0 & -1 & 0 \\ 0 & 0 & 0 & 1 & 0 & -1 \end{bmatrix} \begin{bmatrix} x_1 \\ \dot{x}_1 \\ x_2 \\ \dot{x}_2 \\ x_3 \\ \dot{x}_3 \end{bmatrix} \quad (2.6)$$

or

$$\mathbf{x}_{FF} = \mathbf{T}_{LF}^{FF} \mathbf{x}_{LF} \quad (2.7)$$

where:

$\mathbf{x}_{FF}$  is the states of the Follower-Follower approach

$\mathbf{T}_{LF}^{FF}$  is the 6x6 Transformation Matrix

$\mathbf{x}_{LF}$  is the states of the Leader-Follower approach

This transformation matrix means that there is a direct relationship between the two descriptions. Since this matrix is of full rank, therefore the inverse exists, we can readily shift from one description to another by simply multiplying through by the transformation matrix or its inverse, depending on how we wish to describe the system.

Since the two approaches are basically equivalent for a 1 DOF model, it is appropriate to select one to be used in the rest of the 1 DOF analysis. The L-F approach is selected based on the fact the symbology of the states is simpler. Equation 2.4, is the model that will be used for the rest of the analysis.

### 2.3.4 Model of an n-Vehicle Column

With the relationship between the two methods of modelling the column, we now want to expand the model to incorporate n vehicles. As shown in Equation 2.4 the model of the column is a  $2n \times 2n$  matrix. There are two states for each vehicle. The resulting equation for the n-vehicle column is:

$$\begin{bmatrix} \dot{x}_1 \\ \dot{x}_1 \\ \dot{x}_2 \\ \dot{x}_2 \\ \vdots \\ \vdots \\ \dot{x}_n \\ \dot{x}_n \end{bmatrix} = \begin{bmatrix} 0 & 1 & 0 & 0 & \dots & 0 & 0 \\ 0 & \frac{-c_1}{m_1} & 0 & 0 & \dots & 0 & 0 \\ 0 & 0 & 0 & 1 & \dots & 0 & 0 \\ 0 & 0 & 0 & \frac{-c_2}{m_2} & \dots & 0 & 0 \\ \vdots & \vdots & \vdots & \vdots & \ddots & \vdots & \vdots \\ \vdots & \vdots & \vdots & \vdots & \vdots & \ddots & \vdots \\ 0 & 0 & 0 & 0 & \dots & 0 & 1 \\ 0 & 0 & 0 & 0 & \dots & 0 & \frac{-c_n}{m_n} \end{bmatrix} \begin{bmatrix} x_1 \\ x_1 \\ x_2 \\ x_2 \\ \vdots \\ \vdots \\ x_n \\ x_n \end{bmatrix} + \begin{bmatrix} 0 & 0 & \dots & 0 \\ \frac{1}{m_1} & 0 & \dots & 0 \\ 0 & 0 & \dots & 0 \\ 0 & \frac{1}{m_2} & \dots & 0 \\ 0 & 0 & \dots & 0 \\ \vdots & \vdots & \ddots & \vdots \\ 0 & 0 & \dots & 0 \\ 0 & 0 & \dots & \frac{1}{m_n} \end{bmatrix} \begin{bmatrix} u_1 \\ u_2 \\ \vdots \\ u_n \end{bmatrix} \quad (2.8)$$

## 2.4 Example

Examples of theoretical discussions serve two purposes. The first is that it demonstrates the applicability of the theory. Second, it can be used to verify any findings or conclusions derived during a theoretical discussion. We used the example below to demonstrate how the L-F approach to modeling could be used to model an actual three-vehicle column.

For the example, we again selected a three-vehicle column consisting of two different types of vehicles. This size column is the smallest size which enables us to study both the interval between the lead vehicle and each adjacent vehicle and the interval between each trailing vehicle. For the first vehicle in the column, we selected the Army's new replacement for the Jeep, the High Mobility Multi-Purpose Wheeled Vehicle (HMMWV). The second vehicle in the column was chosen to be the Army's Main Battle Tank, the M1 Abrams. We chose another HMMWV as the third vehicle



in the column. This setup has two advantages. First, it demonstrates this approach is applicable to a variety of vehicle types. Second, by placing the tank as the middle vehicle we will be able to study how vehicles with different characteristics perform in the column. This second advantage will be discussed in greater detail in the next chapter.

### 2.4.1 Developing the Model Parameters

To apply Equation 2.4 to the column described above, the coefficients of  $m_i$ ,  $c_i$ , and  $F_i$  need to be determined for each vehicle. The masses were obtained from the operators manual for each vehicle. The basic weight of the HMMWV is 3402 kg (4000 lb) and the weight of the M1 is 54,431 kg (120,000 lb).

The drag coefficients were more difficult to obtain. The operator's manual specifies an acceleration specification profile and a top speed for each vehicle. The M1 accelerates from 0-20 mph in 7 seconds and has a top speed of 45 mph. The HMMWV accelerates from 0-30 mph in 7 seconds and has a top speed of 70 mph. Using the assumption that all forces are linear, we developed a MATLAB simulation for a generic vehicle and included the mass of the vehicle and selected a value for both the input, the damping coefficient, and zero's for the two initial conditions. The simulation plotted the vehicle's velocity for 40 seconds. We varied the two parameters of input force and drag coefficient until the simulated vehicle's acceleration profile and maximum velocity matched that of the real vehicle. The input force which was used to simulate this performance was then assumed to be the maximum force the vehicle is capable of generating. The results are shown in Table 2.1.

Table 2.1: Simulated Coefficients of Modeled Vehicles

Vehicle	Mass (kg)	Input Force (N)	Damping Coefficient (kg/sec)
M1 Abrams	54,431	100,000	5,000
HMMWV	3402	9000	280

## 2.4.2 Model of the Column

The model of this example is derived by combining Equation 2.4 and the entries from Table 2.1. The resulting mathematical model is:

$$\dot{\mathbf{x}} = \begin{bmatrix} 0 & 1 & 0 & 0 & 0 & 0 \\ 0 & -.0823 & 0 & 0 & 0 & 0 \\ 0 & 0 & 0 & 1 & 0 & 0 \\ 0 & 0 & 0 & -.0919 & 0 & 0 \\ 0 & 0 & 0 & 0 & 0 & 1 \\ 0 & 0 & 0 & 0 & 0 & -.0823 \end{bmatrix} \mathbf{x} + \begin{bmatrix} 0 & 0 & 0 \\ 2.9 \times 10^{-4} & 0 & 0 \\ 0 & 0 & 0 \\ 0 & 1.8 \times 10^{-5} & 0 \\ 0 & 0 & 0 \\ 0 & 0 & 2.9 \times 10^{-4} \end{bmatrix} \mathbf{u} \quad (2.9)$$

## 2.5 Summary

In this chapter, we first developed the equations of motion for a single vehicle using Newton's Second Law. Two methods were examined that could be used to tie together three separate vehicle models into one model of a convoy. A relationship was then developed between the two methods so that only one could be discussed without loss of generality. The model of the column was then generalized to incorporate  $n$  vehicles. Equation 2.4 describes model of a 1 DOF, three-vehicle column. The chapter concludes when this model is applied to an to an actual three-vehicle example.

## Chapter 3

# Developing a Difference Equation for the Convoy

### 3.1 Introduction

In the previous chapter, we developed a mathematical model of a semi-robotic convoy. In this chapter we expand this model to a discrete difference equation of the same column. The chapter begins with a discussion of sample-data systems. We then discuss two methods for selecting the appropriate sampling interval for the system. The digital description of the three-vehicle column is then developed and the chapter concludes with a discussion of the simulation of the system.

### 3.2 Digital Systems

Before discretizing the system, it is important to understand why we would want a digital system. The first reason is that a digital system can be quickly and cheaply simulated with software on a personal computer. The simulation of a continuous system requires an analog controller which must be wired to represent the system. The digital system is extremely flexible in that the software is easily modified. The continuous, or analog, system may require rewiring if significant modifications are

made to the model. Finally, the digital system is expressed in terms of an exact difference equation within the limits of certain assumptions which will be detailed in the next section. The differential equation of the continuous system requires integration.

As shown in Equation 2.4, the convoy is a continuous system. The introduction of a digital computer in the loop makes it a sampled-data system. The discussion of a digitized column begins with an examination of sampled-data system theory. This theory is then applied to Equation 2.4 resulting in a digital description of the three-vehicle column.

### **3.2.1 Discussion of Sampled-Data Systems**

Sampled-data systems are simply continuous systems with a digital computer in the system. The digital computer samples the continuous system using an Analog-to-Digital converter at a frequency characterized by the sampling period,  $T$ . The computer then calculates the control input,  $u(kT)$ , and implements it with a Digital-to-Analog Converter. This is shown graphically in Figure 3.1. If the input were only applied at the sampling instances, the control would be a series of impulses. Ideally, we would like to have a continuous input as it would require a smaller magnitude of control because it is applied over a longer time. Consequently, sampled-data systems utilize a device known as a hold element. This hold element holds the input over the sampling period. The result is a series of step inputs,  $u(T)$ , held over the sampling period instead of a series of impulses.

There are numerous types of hold elements, but the most common is a zero-order

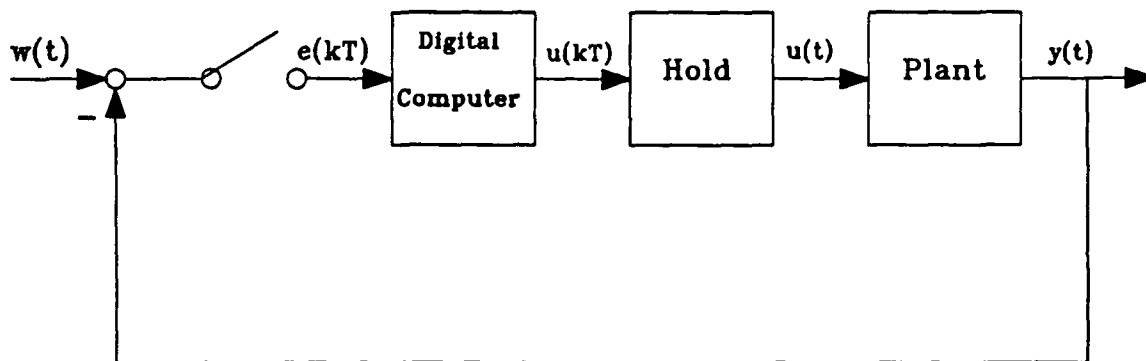

Figure 3.1: Sampled Data System

hold. This type of hold element holds the input constant over the sampling period resulting in a series of step inputs. We will utilize this zero-order hold to digitize the system.

### 3.2.2 The Relationship Between Differential and Difference Equations

Since a difference equation represents the same system as a continuous differential equation, a relationship obviously exists. Therefore, the differential equation which describes the system, Equation 2.3, is the logical starting point (Ackermann.1985). The general solution to this differential equation is:

$$\mathbf{x}(t) = e^{\mathbf{F}(t-t_0)}\mathbf{x}(t_0) + \int_{t_0}^t e^{\mathbf{F}(t-\tau)}\mathbf{g}u(\tau)d\tau \quad (3.1)$$

We want to solve this equation for one sampling period. We assume a zero-order hold so the input remains constant over the sampling interval. The period runs from time  $KT$  to time  $KT+T$ . Substituting these values for  $t_0$  and  $t$  respectively and setting  $v=KT+T-\tau$  results in the following equation:

$$\mathbf{x}(KT + T) = e^{\mathbf{F}T}\mathbf{x}(KT) + \int e^{\mathbf{F}v}dvgu(KT) \quad (3.2)$$

This equation is a vector difference equation and can be written as

$$\mathbf{x}(k + 1) = \mathbf{A}\mathbf{x}[k] + \mathbf{b}u[k] \quad (3.3)$$

where:

$$\mathbf{A} = e^{\mathbf{F}T} = \sum_{i=0}^{n-1} c_i(T)\mathbf{F}^i$$

$$\mathbf{b} = \int_0^T e^{\mathbf{F}v}\mathbf{g}dv$$

With the assumption the sampling period,  $T$ , is known, the coefficients  $A$  and  $b$  can be solved knowing that any exponential can be written as an infinite series and knowing the Cayley-Hamilton Theory which states that every square matrix satisfies its own characteristic equation. The  $A$  matrix is solved first. This solution calculates the values of  $c_i$ . These values can be substituted into  $b$  and directly integrated. This conversion process converting,  $(F,g)$  of the continuous system to  $(A,b)$  of the discrete system, has been programmed in MATLAB software as the function C2D, and will be used throughout this thesis.

### 3.3 Selection of the Sampling Period

As can be seen from Equation 3.3, the selection of the sampling interval has a great impact on the digital system so it is important to carefully choose this value. The initial tendency is to select  $T$  as small as possible to simulate as closely as possible the continuous system. There are two problems with this. First, the smaller the sampling interval the more expensive the hardware becomes. Second, for a given set of eigenvalues, a smaller  $T$  reduces the amount of time the control can be applied which increases the magnitude of the control input. The actuators which implement the control have saturation limits which cannot be exceeded. The smaller  $T$  becomes, the more significant the actuator constraints become. On the other hand, the selection of  $T$  cannot be too large. A minimum bandwidth is required for adequate system response (Ackermann, 1985). Additionally, the control must be applied at a frequency which keeps the system from becoming unstable. For example, it would not be acceptable to sample a column of vehicles traveling at 60 mph once every hour. The choice of the sampling interval is, therefore, a compromise between these concerns. Below, we examine two methods of selecting,  $T$ , the

sampling interval.

### 3.3.1 Ackermann's Rule of Thumb

There is a Rule of Thumb which provides a good initial guess at the value of  $T$  (Ackermann, 1985). This Rule is based on the area of the Controllability Region. The Controllability Region is the area bounded by the initial conditions from which the output can be moved to zero in  $N$  steps. Plotting the area of the Controllability Region,  $F_n$ , versus the corresponding number of steps,  $N=1,2,3,\dots$ , the area exponentially rises to a value that corresponds approximately to the area where  $N=4$ .  $F_n$  is a function of  $\sin(\omega T)$  and  $F_n$  goes to zero when  $\omega = \pi$ . Since there is no great increase in the controllability region for  $N>4$ , it follows that  $T \leq \frac{\pi}{4}\omega$ . The Controllability Region can also be written as a function of the absolute value of the desired closed-loop eigenvalue,  $|s_i|$ , Rule of Thumb can be restated as follows:

$$T \leq \frac{\pi}{4|s_i|} \quad (3.4)$$

It should be noted here that this is only a Rule of Thumb. Sometimes this will not produce an acceptable sampling interval. If this is the case, another method of selecting the sampling interval needs to be explored.

### 3.3.2 Another Approach for Selecting the Sampling Interval

This second approach is a technique which is specific for semi-robotic convoys. This sampling interval is derived based on the vehicle's performance in the column so that collisions are avoided. It begins with the assumption that each vehicle that each



vehicle can stop in approximately the same distance. We also know that the interval between adjacent vehicles must be maintained to  $\pm 5\%$  of the specified distance. This is simply the steady-state error,  $e_{ss}$ . The absolute worst case for maintaining the interval is when the lead vehicle stops immediately after the system is sampled. The lead vehicle is stopping during the sampling period while the trailing vehicles are maintaining the previous velocity. For the trail vehicle to stop within the error specification, the trail vehicle needs to sense the stopping of the lead vehicle while the trail vehicle is still within the error specification. The time it takes for the trail vehicle to travel the distance of the error specification, therefore becomes the recommended sampling interval. The equation is shown below.

$$T = \frac{e_{ss}}{v_{max}} \quad (3.5)$$

where:

$e_{ss}$  is the steady-state error specification

$v_{max}$  is the maximum speed the convoy can travel

## 3.4 Digitizing the Model of the Column

In this section, we apply the sampled-data theory to both the n-vehicle column and the three-vehicle column example. We first derive a digital model of the n-vehicle column. This results in a general description of the semi-robotic convoy. We then apply this general description to the three-vehicle column example.

### 3.4.1 Digitizing the n-Vehicle Column

As previously stated, one of the objectives of this thesis is to derive a generic description of the semi-robotic convoy. Therefore, it is important that each step of

the analysis be applicable to the n-vehicle model derived in the previous chapter. For this reason, we want to show the discrete model of the n-vehicle column. The digital description of an n-vehicle column combines Equation 2.8 with the derivation outlined in Section 3.2.2. The resulting digital description of the convoy is shown below:

$$\mathbf{x}(k+1) = \mathbf{A}\mathbf{x}[k] + \mathbf{b}u[k] \quad (3.6)$$

where:

$\mathbf{A}$  is a  $2n \times 2n$  matrix

$\mathbf{x}[k]$  is the  $2n \times 1$  state vector

$u[k]$  is the  $n \times 1$  input vector

### 3.4.2 Digitizing the Three-Vehicle Column Example

Equation 2.9 represents the continuous system  $(\mathbf{F}, \mathbf{g})$ , for a three vehicle, 1 DOF semi-robotic convoy. To digitize this system, we must first determine what the sampling interval should be. Using Ackermann's Rule, we must first determine the open-loop eigenvalues of the system. Since there are six states, there will be six corresponding eigenvalues. These eigenvalues of this system are easily calculated using either  $\det(\lambda I - F) = 0$  or the MATLAB function 'eig(F)'. In symbolic terms, these eigenvalues, or open loop poles, are located at  $s = 0$  &  $\frac{-c_i}{m_i}$ . In terms of the example, Equation 2.9, the following eigenvalues are calculated.

$$s_i = \begin{bmatrix} 0 \\ -.0823 \\ 0 \\ -.0919 \\ 0 \\ -.0823 \end{bmatrix} \quad (3.7)$$

In order to select the proper value of  $s_i$ , we select the maximum value of the absolute values of the eigenvalues. In this case, we select  $|s_4| = .0919$ . Substituting this value into Equation 3.4, yields the recommended time step of  $T = 8.5$  seconds. Sampling every 8.5 seconds does not seem to be an acceptable interval. At 20.11 meters/second (45 mph), the maximum speed of the slowest vehicle, each vehicle moves over 170 meters during this time. If the lead vehicle stopped immediately after the sample was taken, the trail vehicle would travel 170 meters before another sample was taken and a collision could likely occur. Obviously, the sampling interval needs to be faster, but why didn't the Rule of Thumb work for this system?

The sampling interval recommended by Ackermann is based on the eigenvalues of the open-loop system. These values are a function of the ratio of the damping coefficient to the mass of the vehicle. Since the masses of these military vehicles are so large, the eigenvalues will always be small. Equation 3.4 results in large sampling intervals for small eigenvalues which is unacceptable for this application.

Since the Rule of Thumb did not provide an acceptable sampling interval, we will now try the one recommended for the semi-robotic convoy. In the case of our three vehicle column of the two HMMWV's and the M1, the M1 has the slowest overall speed of 20.11 meters/sec (45 mph). This is  $v_{max}$ . The normal interval between

vehicles in a military convoy is 100 meters. From the specifications,  $e_{ss}$  is 5 meters. Substituting these values into Equation 3.5 yields an sampling interval of  $T=.25$  seconds. Intuitively, this appears to be an acceptable sampling interval. Simulations of the system will verify if it is fast enough to adequately control the vehicle.

We can now apply the results of Equation 2.9 with Equation 3.3 and the sampling interval calculated above. The resulting digital description of the column is

$$\mathbf{x}_{k+1} = \begin{bmatrix} 1 & .2474 & 0 & 0 & 0 & 0 \\ 0 & .9796 & 0 & 0 & 0 & 0 \\ 0 & 0 & 1 & .2472 & 0 & 0 \\ 0 & 0 & 0 & .9773 & 0 & 0 \\ 0 & 0 & 0 & 0 & 1 & .2474 \\ 0 & 0 & 0 & 0 & 0 & .9796 \end{bmatrix} \mathbf{x}_k + \begin{bmatrix} .0912 & 0 & 0 \\ .7274 & 0 & 0 \\ 0 & .0057 & 0 \\ 0 & .0454 & 0 \\ 0 & 0 & .0912 \\ 0 & 0 & .7274 \end{bmatrix} 10^{-4} \mathbf{u}_k \quad (3.8)$$

### 3.5 Discussion of the Digital Simulation

With the difference equation of Equation 3.8, the system can easily simulated using a digital computer and MATLAB software. Since this model is a difference equation, the simulation simply steps through iterations of the equation. The states of the equation, position and velocity of each vehicle, are calculated for each sampling instance in the form of  $\mathbf{x}_{k+1}$ .

There are two aspects of the simulation which should be explained.

1. To ensure that the simulation represents the actual vehicles as accurately possible, the simulation incorporates the data in Table 2.1. The entry which has the most significant impact on the simulation is the maximum input force. The inputs which are calculated in the simulation are checked against this

maximum value. If the calculated value exceeds the maximum value, the actual input to the vehicle is clipped to equal the maximum allowable input.

2. Fuel efficiency is as big of a concern to the military as it is to everyone. Therefore, the simulation does not allow for a negative force. The natural damping of the vehicle is allowed to slow down the vehicle. Brakes for the vehicles are not included in the simulation.

### **3.6 Summary**

In this chapter, we examined digital theory and two methods of selecting the sampling interval for a semi-robotic convoy. The interval was then selected using a method specifically designed for these convoys. The n-vehicle column was expressed as a difference equation and then the three-vehicle example column was converted. The last section of the chapter gives a description of the simulation and some of the particular aspects which are necessary to ensure the simulation matches the performance of the actual column of vehicles.

## Chapter 4

# Developing and Simulating a State Feedback Control Law

### 4.1 Introduction

In the previous three chapters, the necessary descriptions of the column have been developed. This was done so that a control law could be developed and evaluated for the system. In this chapter, we first determine if the system can indeed be controlled. Once we are satisfied that our goal is achievable, we derive a control system for the 1 DOF convoy using state feedback control theory. This theory is then examined in terms of system performance. Using the pole-placement technique of selecting feedback gains, we simulate the system to determine the adequacy of the state feedback control of the semi-robotic convoy.

### 4.2 Controllability

Before analyzing any type of control, it is necessary to determine whether or not the system is capable of being controlled. If it cannot be controlled then there is no need to continue. How can we tell? A controllability criteria has been developed and is outlined below (Ogata, 1990).

A system is said to be controllable at time  $t_0$  if it is possible by means of an unconstrained control vector to transfer the system from any initial state  $\mathbf{x}_{t_0}$  to any other state in a finite interval of time (Ogata, 1990). The derivation of the controllability criteria begins with Equation 3.1, which is the general solution to the differential equation shown in Equation 2.1. If we assume that the final state is  $\mathbf{x}(t_1)=0$ , the equation can be simplified.

$$\mathbf{x}(0) = - \int_0^{t_1} e^{\mathbf{F}\tau} \mathbf{g}u(\tau) d\tau \quad (4.1)$$

Again, we know that any exponential can be written as an infinite series and we recall Cayley-Hamilton. Since  $\mathbf{F}$  is a square matrix, the infinite series  $e^{-\mathbf{F}\tau}$  can be expressed in as a finite series,  $\sum_{i=0}^{n-1} \alpha_i(\tau)\mathbf{F}^i$ . This finite series is then substituted into the above equation.

$$\mathbf{x}(0) = - \sum_{i=0}^{n-1} \mathbf{F}^i \mathbf{g} \int_0^{t_1} \alpha_i(\tau)u(\tau) d\tau \quad (4.2)$$

Letting the integral portion of the equation equal  $\beta_i$ , the final form is

$$\mathbf{x}(0) = -[\mathbf{G} \ \mathbf{F}\mathbf{g} \ \dots \ \mathbf{F}^{n-1}\mathbf{g}] \begin{bmatrix} \beta_1 \\ \beta_2 \\ \vdots \\ \beta_{n-1} \end{bmatrix} \quad (4.3)$$

For a system to be completely controllable, for any given initial conditions, the matrix  $[\mathbf{G} \ \mathbf{F}\mathbf{g} \ \dots \ \mathbf{F}^{n-1}\mathbf{g}]$ , known as the Controllability Matrix, must be of full rank. If the matrix is of full rank, then all the column vectors are linearly independent and

span the solution space. Therefore, according to the definition, all values of  $x_{t_0}$  can be moved to any other point with an unconstrained input. If the matrix is not of full rank, then there are sets of initial conditions which cannot be moved to  $x(t_s)=0$ . The system is therefore uncontrollable.

In the example of the three vehicle column, the values from Equation 2.9 are used to calculate the controllability matrix. Since the  $g$  matrix has three columns for the three inputs, the controllability matrix is a  $6 \times 18$  matrix. The matrix has a rank of six. The matrix is therefore full rank and the system is completely controllable. Since the  $(A,b)$  description of the system is a function of  $T$ , it is also necessary to check the controllability of the specific sampled-data system. As in the continuous system, the controllability matrix is a  $6 \times 18$  matrix and it is full rank. With the knowledge that both the continuous system and the sampled-data system for  $T=.25$ seconds are controllable, we can therefore begin our analysis of a state feedback control system.

### 4.3 State Feedback Control Theory

The object of any control system is to drive the actual output of a system to that output desired by the controls engineer. With state-feedback control, this is accomplished by multiplying the output by a feedback gain and then adding this quantity to the reference input. The result is a control input which drives the actual output towards the desired output. This method works because the feedback gains in effect change the characteristic equation and thus the system response is modified. State-Feedback control utilizes the states of the system for feedback rather than the output. In some systems, like the one we are dealing with, the states are measured. State-feedback control requires that the states either be estimated or measured. If



these states are available and the system is controllable, then state feedback control can be used to control the system.

### 4.3.1 Application of the State Feedback Control

In the case of the semi-robotic convoy, the states of the system are the position and velocity of each vehicle. With the model described in the previous chapter, the states of each vehicle are measurable. The control input can then be calculated using the following equation:

$$u_i = K_1(x_1 - x_i) + K_2(\dot{x}_1 - \dot{x}_i) \quad (4.4)$$

where:

- $u_i$  is the input to the  $i$ th vehicle in the column
- $x_1$  and  $\dot{x}_1$  are the states of the lead vehicle
- $x_i$  and  $\dot{x}_i$  are the states for the  $i$ th vehicle in the column
- $K_1$  is the feedback gain for the difference in position
- $K_2$  is the feedback gain for the difference in velocities

In its present form, Equation 4.4 will drive the output of the trailing vehicle to the same output as the lead vehicle. The output of the lead vehicle is position. If the trail vehicle output is the same as the lead vehicle, the two vehicles would collide. What we really want is for the trail vehicle to follow the lead vehicle at a given interval. To implement this, another term needs to be included in the control input. This term,  $C_i$ , is the interval behind the lead vehicle the trail vehicle is supposed to follow.  $C_i$  is subtracted from the difference of the positions of the two vehicles. This term essentially turns off the position portion of the control when the proper interval is achieved. This new control law, also applicable to the  $n$ -vehicle column, is shown

in Equation 4.5 and is displayed graphically for one trail vehicle in Figure 4.1.

$$u_i = K_1(x_1 - x_i - C_i) + K_2(\dot{x}_1 - \dot{x}_i) \quad (4.5)$$

where:

$C_i$  is the interval behind the lead vehicle

### 4.3.2 Impact of State Feedback on System Performance

Now that we have both a model of the system and a model of the control law, we want to look at how the system is going to perform. The most important specifications are the maintenance of both the interval between vehicles and the column length. This means that we are more concerned with the steady-state response of the system than we are with the dynamic response. Since both of these responses are functions of the feedback gains selected in Equation 4.5, each of these responses are addressed below.

#### Steady-State Response

The steady-state of a system is the response to an input after all the dynamics have died out. Any system can have steady-state error in response to certain types of inputs. This is based on the model of the system, either the transfer function of the system or the state description. Figure 4.2 shows the relationship of the error transfer function from the closed-loop state space description.

From this error transfer function, we can calculate the steady-state error for a given input. The input to our model of the semi-robotic convoy is the force applied at the tires. This represents a ramp input for position and a step input for velocity. In the

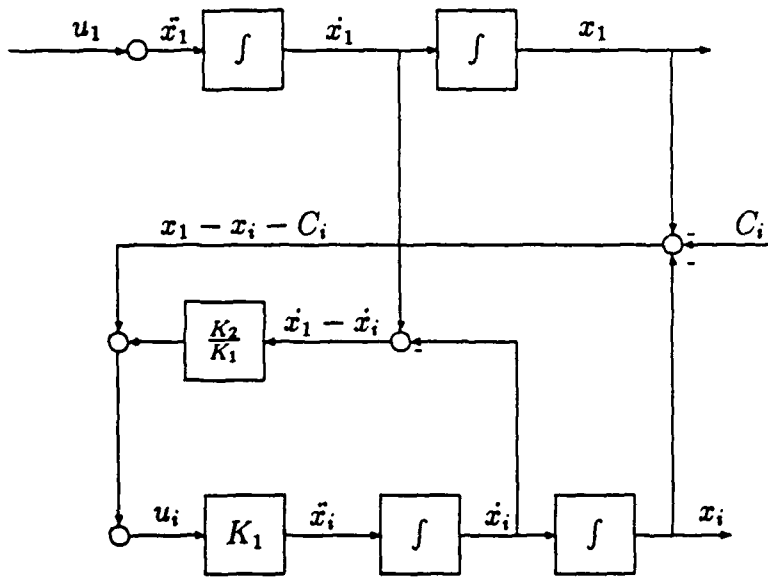
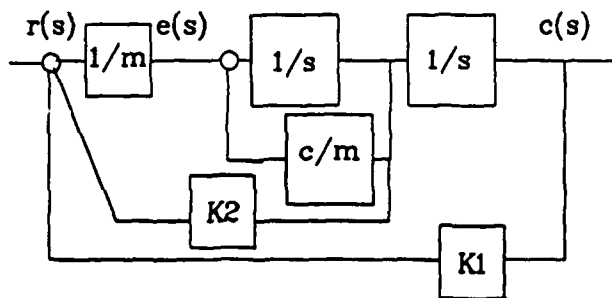
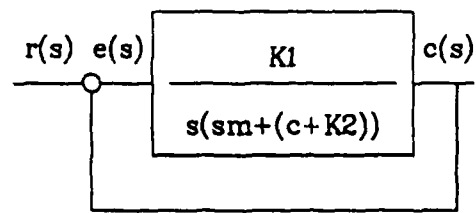

Figure 4.1: Block Diagram of State Feedback Control for One Vehicle



a) Diagram of Closed Loop System



b) Diagram w/ unity feedback

$$\frac{e(s)}{r(s)} = \frac{s(sm+(c+k2))}{s(sm+(c+K2))+K1}$$

c) Error Transfer Function

Figure 4.2: Derivation of the Closed-Loop Error Transfer Function

terms of the transfer function, a ramp input,  $r(s) = \frac{r_0}{s^2}$ . We can find the steady-state error to this input by multiplying the transfer function by this input and using the Final Value Theorem.

$$e_{ss} = \lim_{s \rightarrow 0} s \frac{s(s + \frac{c_i}{m_i} K_2)}{s(s + \frac{c_i}{m_i} K_2) + K_1} \frac{1}{s^2} \quad (4.6)$$

Taking the limit of this equation yields the steady-state error of the system in response to a ramp input.

$$e_{ss} = \frac{(c_i + K_2)r_0}{K_1} \quad (4.7)$$

We see that the semi-robotic convoy has steady-state error for a constant velocity, which is a ramp input for position. The magnitude of this error is proportional to the magnitudes of the drag coefficients, the velocity feedback gain and the ramp input. The error is inversely proportional to the magnitude of the position feedback gain. The initial inclination is this is not acceptable because we really don't want steady-state error. Before this decision can be made, we need to examine the system because it is possible that we could find a set of feedback gains which produce an acceptable steady-state error. This, obviously, will be a key consideration as to whether or not state feedback is an acceptable method of control for the 1 DOF semi-robotic convoy problem. This will be discussed in detail later in this chapter.

### Transient Response

The transient response of a system describes how the system responds to an input prior to settling down to the steady-state values. Since we are dealing with a second-

order model, the dynamics are controlled by the following equation.

$$s^2 + 2\zeta\omega_n s + \omega_n^2 = 0 \quad (4.8)$$

where:

$\zeta$  is the damping ratio  
 $\omega_n$  is the natural frequency

The value of  $\zeta$  determines how much transient oscillation will occur and how much overshoot we have prior to steady-state.

In our initial model of a single vehicle, the characteristic equation was

$$s(s + \frac{c_i}{m_i}) = 0 \quad (4.9)$$

This means we have eigenvalues, or roots to the characteristic equation, at  $s=0$  and  $s=-\frac{c_i}{m_i}$ . When we apply the state feedback to the system, the characteristic equation becomes

$$s^2 + \frac{K_2 + c_i}{m_i} s + \frac{K_1}{m_i} = 0 \quad (4.10)$$

From Equation 4.10, it is obvious that the values of  $K_1$  and  $K_2$  determine the corresponding values of  $\omega_n$  and  $\zeta$ . The next section deals with this in detail but for now it is sufficient to know that we can achieve a desired transient response with the selection of the appropriate feedback gains. The question is whether or not we can optimize both the steady-state error and the transient response for an overall acceptable system response.

## 4.4 Selecting State Feedback Gain Sets

The purpose of a state feedback control law is to use the states of the system in conjunction with the feedback gains to make the system behave in a specific manner. There are several ways that these feedback gains can be determined. For this 1 DOF problem we will use the pole-placement technique. Although other methods (such as Linear Quadratic Regulator) are available, the purpose of this section is to examine the feasibility of state-feedback control. The pole-placement technique is sufficient to tell us whether or not an acceptable steady-state error can be achieved using state feedback. With these gain sets, the system will be simulated and the results discussed.

### 4.4.1 Pole-Placement

The technique of pole-placement is a method for determining state feedback gains based on the selected dynamics of the closed-loop system. Equation 4.10 shows how the characteristic equation is affected by the feedback gains. If we equate this equation with a system with a known response, Equation 4.8, the feedback gains can be calculated such that the eigenvalues of the two equations will be equivalent. The benefit of this technique is it can provide the controls engineer with a great deal of insight to how the closed-loop system will perform before the control it is actually applied to the system. The technique for finding these appropriate gain sets is described below.

## Discussion of Pole-Placement Technique

Before applying state-feedback gains to a closed-loop system, we need to decide how we want the system to perform. Equation 4.8 shows a generic second-order equation. The values selected for  $\zeta$  and  $\omega_n$ , determine the both the coefficients of the equation and the location of the eigenvalues. We can relate these coefficients to actual system performance. Therefore, we can specify how we want the system to perform which in turns specifies the desired characteristic equation.

For a second-order system, there are numerous system performance characteristics which can be specified. We have two values ( $\zeta$  and  $\omega_n$ ) that can be varied to change the eigenvalues and thus modify the system's performance. Two of the most common specifications are the Percent Maximum Overshoot (PO) and Settling Time ( $T_s$ ). PO is the percentage of the maximum peak value above the steady-state value and  $T_s$  is the time required for the system to reach and stay within 5% of the steady-state value. Both of these characteristics are determined in response to a step input to the system.  $\zeta$  and  $\omega_n$  can be determined from the following equations (Hale, 1988).

$$PO = e^{-(\zeta/\sqrt{1-\zeta^2})\pi} \quad (4.11)$$

and

$$T_s = \frac{3}{\zeta\omega_n} \quad (4.12)$$

The desired characteristic equation, a polynomial, is calculated by substituting  $\zeta$  and  $\omega_n$  into Equation 4.8.



This desired equation is then equated with the characteristic equation of the closed-loop system. The closed-loop gain sets could then be solved by equating coefficients of the two equations. The result is a closed-loop system with the same characteristic equation as the desired system. We have essentially placed the poles of the closed-loop system at the same location as the poles of the desired characteristic equation.

### **Pole-Placement for the Three Vehicle Column**

Since the model of the three-vehicle column is a sixth-order equation, the initial guess is that there would be six poles to place. This is not the case. The column is comprised of three independent second-order systems. The first system is the lead vehicle. It operates open-loop and the pole locations therefore cannot be altered. The two trailing vehicles, however, operate closed-loop. The characteristic equation which describes each of the trail vehicles is a second-order equation. Since we want each trail vehicle to follow the lead vehicle in the same manner, it is obvious that both vehicles should have the same characteristic equation and thus the same dynamic response. The two trailing vehicles are of different types and will therefore require different feedback gains to achieve the same closed-loop dynamics. The pole-placement problem is therefore simplified from placing six poles to placing the two poles of the second vehicle and then repeating the process to place the poles of the other trail vehicle.

We know from the specifications that  $T_r$  is 5 seconds, the normal interval between vehicles is 100 meters and the interval during the transient response cannot vary more than 20%. From Equations 4.11 and 4.12, these specifications correspond to

values of  $\zeta=.45$  and  $\omega_n=1.33$  rad/sec. The feedback gains were calculated (for the tank  $K_1 = 8.38 \times 10^4$  and  $K_2 = 6.25 \times 10^4$  and for the HMMWV  $K_1 = 5.23 \times 10^3$  and  $K_2 = 3.90 \times 10^3$ ). The closed-loop system was simulated with the initial conditions of all three vehicles at a steady-state velocity 8.96 meters/sec (20 mph). We subjected the system to a step increase in velocity of +6.7 m/sec (15 mph). This large velocity step was selected to better show the dynamics of the system. The results of the simulation is shown in Figure 4.3.

In comparing these results with the system specifications, the only real deficiency is the extreme oscillation of the control force. Obviously, this set of feedback gains is unacceptable because of oscillation. What is interesting is that even with these oscillations, the interval between vehicles remained virtually constant. There was no overshoot, which would have temporarily changed the interval between vehicles. The reason the oscillations had little impact on the interval and there was essentially no overshoot can be attributed to the masses of the vehicles. These masses,  $m_i$ , are extremely large in comparison with the force. These large masses make the vehicle very slow to respond to any input. This verifies our initial speculation that the dynamics of the system output are not a major concern.

The steady-state error for position in this simulation is well within the error specification for the convoy. The error of the first interval is .5343 meters and the second interval error is .4780 meters. If it were not for the excessive oscillations of the control, this would be an acceptable gain set for the implementation of the semi-robotic convoy. Unfortunately, we are forced to continue our search for an acceptable set of feedback gains.

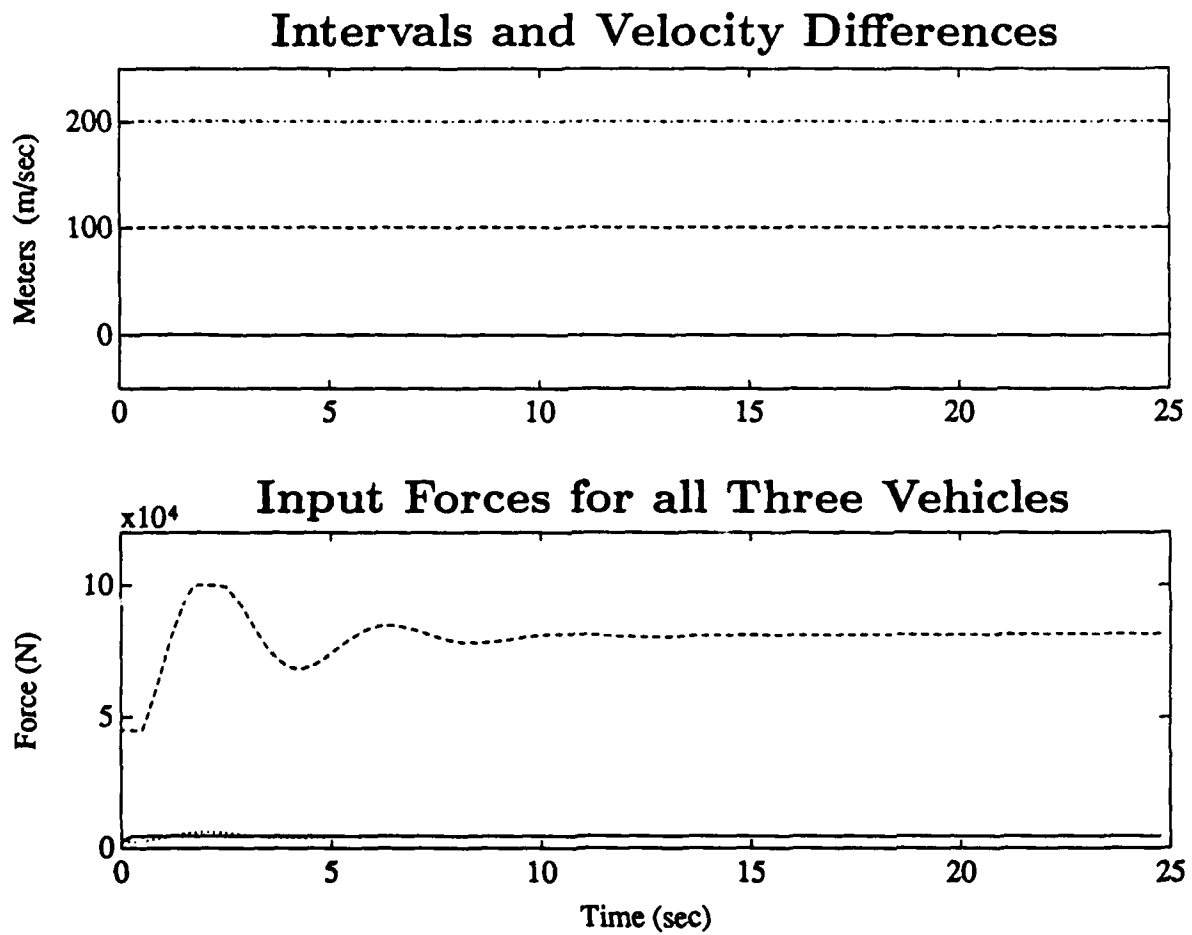

Figure 4.3: Simulation of Ramp Input for Position with  $\zeta=.45$

So how do we find a set of feedback gains which make the system perform in the desired manner? We know  $T_s$  is 5 seconds. The only remaining requirement to fully define the desired characteristic equation is to select a value for  $\zeta$ . Our first try of  $\zeta=.45$  showed us there was virtually no overshoot in an underdamped system. With this knowledge, an iterative technique seems to be an appropriate method for finding the gain sets. We select a variety of  $\zeta$ 's, calculate the feedback gains, and simulate the system with each set of gains. We began with a value of  $\zeta$  of .7 and then incremented it to 1.3 in .1 increments. For each of these seven values, the following information was calculated: eigenvalues of the desired characteristic equation (E-values), the feedback gains for the M1 Tank ( $k_{1T}$  and  $k_{2T}$ ), and the feedback gains for the HMMWV ( $k_{1H}$  and  $k_{2H}$ ), the 1st interval steady-state error (1st  $e_{ss}$ ) in meters, and the 2nd interval steady-state error (2nd  $e_{ss}$ ) in meters. The results of this are shown in Table 4.1.

Table 4.1: Comparison of Desired Characteristic Equations

$\zeta$	E-values	$k_{1T} \times 10^4$	$k_{2T} \times 10^4$	$k_{1H} \times 10^3$	$k_{2H} \times 10^3$	1st $e_{ss}$	2nd $e_{ss}$
.7	$-.6 \pm .6121i$	3.48	5.64	2.17	3.55	2.34	2.12
.8	$-.6 \pm .4500i$	2.66	5.54	1.66	3.49	3.05	2.76
.9	$-.6 \pm .2906i$	2.10	5.47	1.32	3.44	3.86	3.49
1	$-.6 \pm .0000i$	1.71	5.42	1.07	3.42	4.77	4.31
1.1	$-.8500$ $-.3500$	1.41	5.38	.882	3.39	5.21	5.21
1.2	$-.9317$ $.2683$	1.19	5.36	.741	3.38	6.84	6.19
1.3	$-.9834$ $-.2166$	1.01	5.33	.631	3.36	7.99	7.24

The only information which is not available from this table is how the control force is applied. Figure 4.4 show the response of the system when the damping ratio is relatively high, 1.3. As expected, there is very little excess control applied to the system. Equation 4.7 shows that as the ratio of  $\frac{k_2}{k_1}$  increases, so does the steady-state error. For this particular ramp input all  $\zeta$ 's  $> 1$  produce unacceptable steady-state error. Figure 4.5 depicts the system with a damping ratio of 1. Here, we have a critically damped system. In this particular simulation, it results in acceptable performance. There is very little unnecessary control applied and the steady-state error is in the acceptable range. Since all specifications are met, it is obvious that, at least in this situation, it is possible to find a set of feedback gains which produces acceptable steady-state error with excessive control force oscillation. But have we accomplished anything in terms of designing a generic control system for a semi-robotic convoy?

#### 4.4.2 Conclusions

We don't believe the application of state feedback is an acceptable solution to the 1 DOF semi-robotic convoy problem. We are trying to design a system which can be applied to a wide variety of vehicles. If we were to accept this performance, which due to the steady-state error is marginal at best, the semi-robotic convoy system may not be compatible with all systems. Some applications may have tighter error specifications which may or may not be able to be met. Since the steady state error is a function of the magnitude of the input and the size of the feedback gains, it is impossible to design a generic system for all applications. The ideal solution would be to find a way to eliminate the steady-state error so the only real concern would

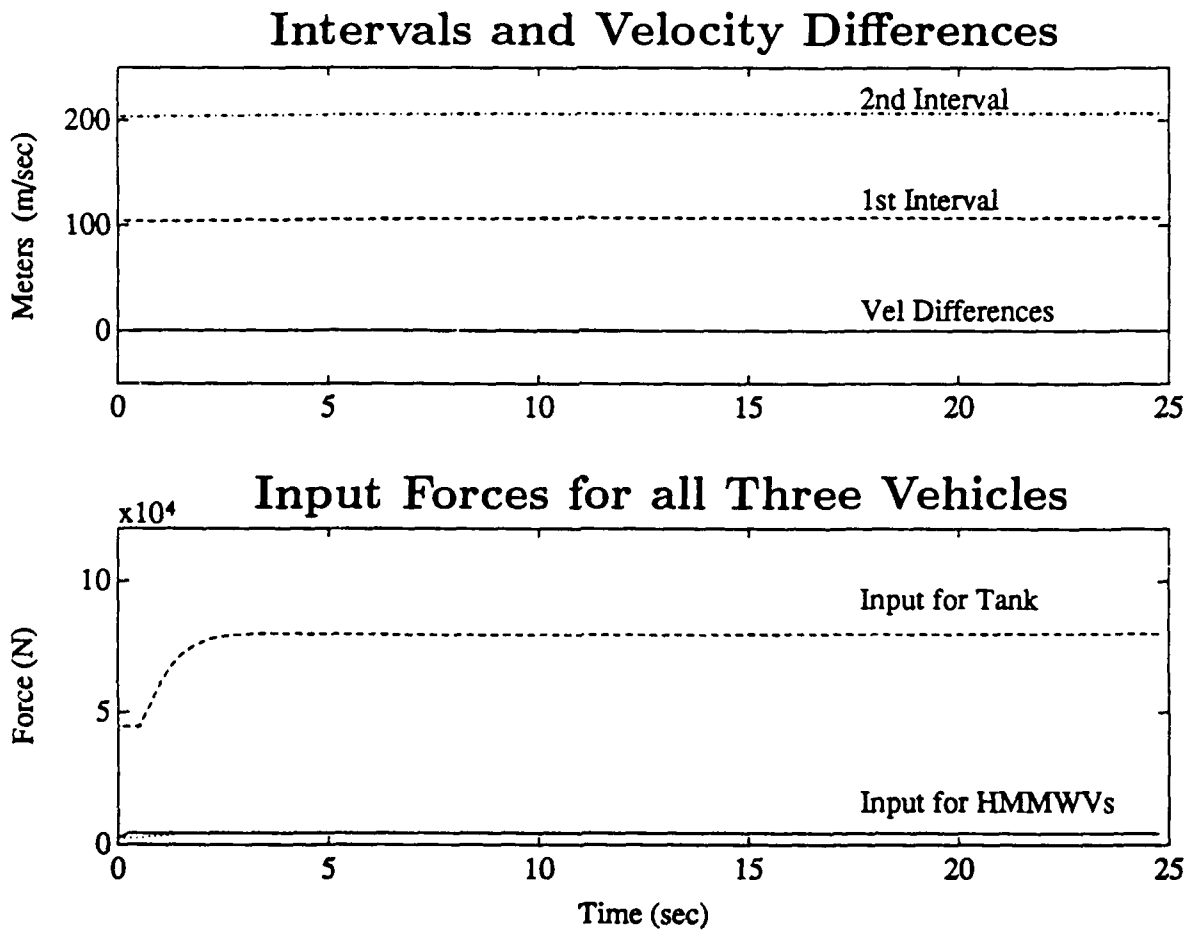

Figure 4.4: Simulation of Ramp Input for Position with  $\zeta=1.3$

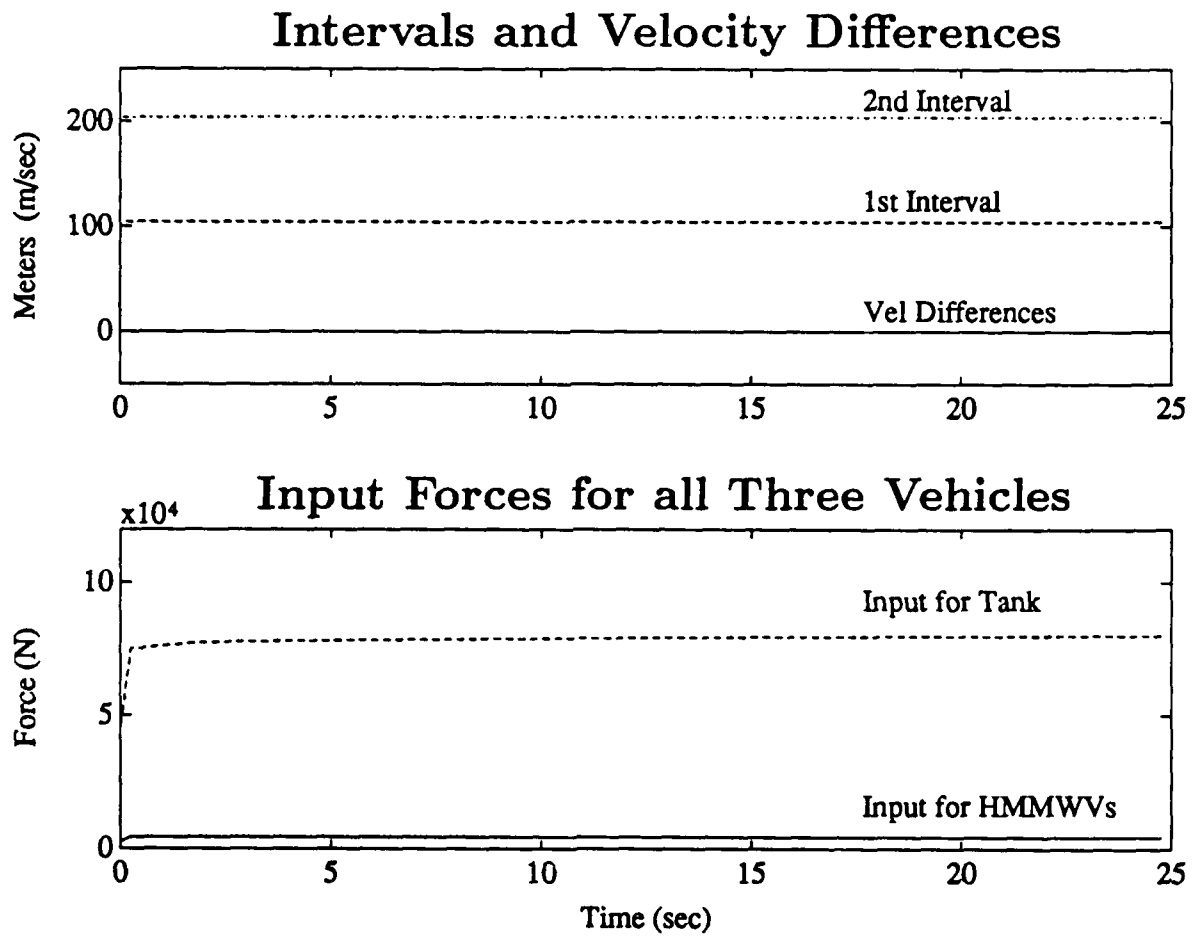

Figure 4.5: Simulation of Ramp Input for Position with  $\zeta=1.0$

be to minimize the oscillations of the control force. This is what we do in the next chapter.

## 4.5 Summary

In this chapter, we analyzed the state-feedback control theory for the three-vehicle column. We first determined that the three-vehicle column was indeed controllable and then developed a state-feedback control law that would allow each of the trailing vehicles to follow the lead vehicle at the specified distance. We then selected the feedback gains using the pole-placement technique. The system was simulated and we found out that there is a distinct trade off between control force oscillation and steady-state error, both of which are important to any military convoy. After looking at a variety of different sets of feedback gains, we concluded that even though a particular set of gains produced the desired performance in this particular application, the technique was not acceptable for implementation as a generic system.



## Chapter 5

# Eliminating Error With a Series Compensator

### 5.1 Introduction

In the previous chapter, we learned the seriousness of steady-state error in the application of the control of a semi-robotic convoy. In this chapter we will develop a technique to eliminate this error from the 1 DOF problem. We begin with an analysis of why the error exists and how can we get rid of it. Next we use general discussion on how series compensators actually work and why they can be used to solve our problem. We will then apply this to a generic convoy to see how it modifies the system. The final step in the chapter is to apply this compensator to our three-vehicle system and verify that it works as well as we think it should.

### 5.2 Analysis of the Steady-State Error

Equation 4.7 shows the steady-state error equation for the closed-loop semi-robotic convoy using state feedback responding to a ramp input. Using this equation and the derivation leading up to it, we would like to determine why there is steady-state

error and what can be done, if anything, to eliminate it.

The derivation of the steady-state error came about through the use of the Final Value Theorem applied to the LaPlace transfer function of the system. As “ $s$ ” approached zero, the steady-state error term was the residual. It was the only value left that was not a function of “ $s$ ”. If we could somehow make this term a function of “ $s$ ”, the steady-state error would be zero. Figure 4.2b shows the closed-loop transfer function with unity feedback. If this transfer function had an  $s^2$  term in the denominator, the Figure 4.2c would have an  $s^2$  term in both the denominator and the numerator. If this were the case, as the limit was taken as “ $s$ ” approached zero of the transfer function multiplied by a unit ramp input, each term in the numerator would be multiplied by an “ $s$ ” and the steady-state error would therefore be zero, which is what we want. We must therefore add an additional integrator,  $\frac{1}{s}$ , to the system.

To summarize, we need to have a plant with an  $s^2$  term, or two integrators, in the denominator of the transfer function when a ramp input is applied if we want zero steady-state error. This is known as a type 2 system because of the order of the “ $s$ ” in the denominator. We therefore must change the order of the plant to achieve our goal. But is it really possible to change an open-loop description of a plant? We know we can't change the open-loop plant, but we can change the closed-loop system so we can get the characteristics of the desired open-loop plant. This is accomplished using a series compensation which is described below.

### 5.3 Series Compensation Theory

Using a series compensator to control a system is an entirely different technique than state feedback. With state feedback, we fed back information in the form of states, multiplied that information by a set of feedback gains, and then added it to the reference input. With a series compensator, we work with the transfer function of the system rather than the state space description. The compensator is added to the plant and the output, or position, is fed back to close the loop. This process is shown graphically in Figure 5.1.

The concept of series compensation is that by changing the system by adding an additional device, the overall behavior of the system can be modified to acceptable performance (Ogata, 1990). Since the previous analysis was accomplished in the z-plane, the rest of this discussion of series compensation will also be discussed in the z-plane. The device, or series compensator, is assumed to have equal order in both the numerator and denominator. It has the form

$$d_z = \frac{u_z}{e_z} = \frac{d_m z^m + d_{m-1} z^{m-1} + \dots + d_0}{z^m + c_{m-1} z^{m-1} + \dots + c_0} \quad (5.1)$$

The plant has the transfer function

$$h_z = \frac{B(z)}{A(z)} = \frac{b_{n-1} z^{n-1} + b_{n-2} z^{n-2} + \dots + b_0}{z^n + a_{n-1} z^{n-1} + \dots + a_0} \quad (5.2)$$

where:

$B(z)$  and  $A(z)$  are coprime, or none of their respective roots are equal

With this information, the transfer function of the modified system can be found by

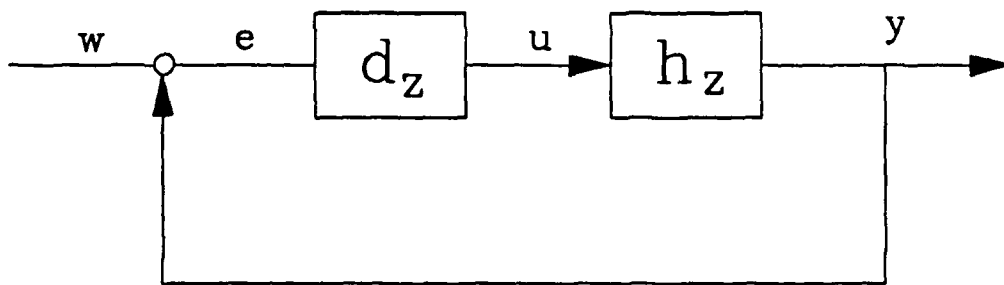

Figure 5.1: Simple Control Loop with a Series Compensator

using block diagram algebra (Hale, 1988).  $h_z$  and  $d_z$  are simply multiplied together. The closed-loop transfer function, with unity feedback, is derived from  $TF = \frac{G}{1+GH}$ . With  $G=h_z d_z$  and  $H=1$ , the transfer function of this simple control loop is shown below.

$$f_z = \frac{h_z d_z}{1 + h_z d_z} \quad (5.3)$$

Since we now know the form of the series compensator, we now need to determine it's order. We know that the plant has order  $n$ . From Equation 5.1 we see that if the compensator is of order  $m$ , then there are  $2m+1$  coefficients available which can be modified. We know that for the overall system to have the desired performance, we need to place the eigenvalues of both the plant and the compensator. Since the plant has  $n$  poles to place and the compensator has  $m$  poles to place, there are a total of  $m+n$  poles which need to be placed. If  $m=n-1$ , then there are enough coefficients in the compensator to place the poles of both the plant and the compensator at the desired locations. Therefore, the compensator needs to be of the order of  $n-1$  (Ackermann,1985).

## 5.4 Applying a Series Compensator to the Semi-Robotic Convoy

In the case of a semi-robotic convoy, each vehicle has a second-order plant with a single integrator in the denominator. We need to add an additional integrator, which will make the plant a type 2 and eliminate the steady state error. To accomplish this, we will first assume that we have added the new integrator. We can do this because the two transfer functions are in series, which means their respective

numerator and denominators are multiplied. The additional integrator is actually in the compensator. but it is more convenient to think of the plant with the new integrator. If we assume the new integrator is part of the plant, then we can design a series compensator to place the poles of this new third-order plant. To place the poles of this new system, we need a second-order compensator. The transfer function of the plant is

$$h_z = \frac{b_2 z^2 + b_1 z + b_0}{z^3 + a_2 z^2 + a_1 z + a_0} \quad (5.4)$$

The transfer function of the compensator is

$$d_z = \frac{d_2 z^2 + d_1 z + d_0}{z^2 + c_1 z + c_0} \quad (5.5)$$

The resulting transfer function of the compensated system is fifth-order. We now want to determine the coefficients  $d_2$ ,  $d_1$ ,  $d_0$ ,  $c_1$ , and  $c_0$ . This is accomplished in much the same fashion as the feedback gains were determined in the previous chapter. We derive a fifth-order desired characteristic equation for the system and equate the coefficients of the two polynomials. We end up with five equations and five unknowns. The unknowns can then be determined. The final step is to substitute the answers back into the characteristic equation for the system and verify that the eigenvalues are in fact where we wanted them.

## 5.5 Series Compensation of the Column

### 5.5.1 The Three-Vehicle Column

We now want to apply this technique of series compensation on our example of the two HMMWV's and the M1 tank. To simplify this process, we will only derive the compensator for the tank in the text of this thesis. Both compensators were designed and included in the simulation, which is described later in this section. The first step is to derive the transfer function of the tank. This was accomplished using the MATLAB SS2TF function which calculates the transfer function from the state description with the following equation.

$$H(z) = c(zI - A)^{-1}b \quad (5.6)$$

The tank transfer function is shown below:

$$h_z = \frac{(.5698z + .5654) \times 10^{-6}}{z^2 - 1.9773z + .9773} \quad (5.7)$$

The next step is to add the integrator to the transfer function of the tank, which results in the following transfer function.

$$h_z = \frac{(.5698z + .5654) \times 10^{-6}}{z^3 - .9773z^2 + .9773z + .9773} \quad (5.8)$$

We then construct the compensator which has the same form as Equation 5.5. These two transfer functions are then multiplied together. The block diagram of the system shown in Figure 5.1 is then reduced to include the unity feedback using Equation 5.3. This fifth-order polynomial is then equated with the desired polynomial and the coefficients of the compensator can then be solved as a set of linear equations.

The key to this technique, as it was in the pole-placement problem, is how do we decide on a desired equation. We used basically the same technique we did before, except now we have five poles to specify. We begin by assuming the dynamics of the new system can be described by a dominant second-order equation. With this assumption, we can use the same second-order desired equations as before. Only this time, we place two poles at each of the specified locations. We select an arbitrary stable pole, which is substantially faster, for the fifth pole. The resulting equations, although fifth-order, will behave as a second-order system. We checked  $\zeta$ 's from .7 to 1.3 in .1 increments. The results of these simulations are discussed below.

### 5.5.2 Simulations of the Three-Vehicle Column

Using the method outlined above, we simulated the system for each of the desired equations. Once the coefficients of the compensator were calculated, the integrator, which had initially been assumed to be in the plant, was moved back to the transfer function of the compensator. The simulation of the system was accomplished using the state space description of both the compensator and the plant. The simulation followed the schematic shown in Figure 5.2. The initial conditions were the same as the previous simulation as was the +6 m/s ramp input.

In all the cases with  $\zeta < 1.0$ , the vehicles were so underdamped that the input was substantially clipped and the system performed very poorly. In some cases, steady-state was not achieved during the 30 second simulation. But even in these poorly performing systems, it was evident that we had eliminated the steady-state error from the problem. Now we simply need to find a system with performance that



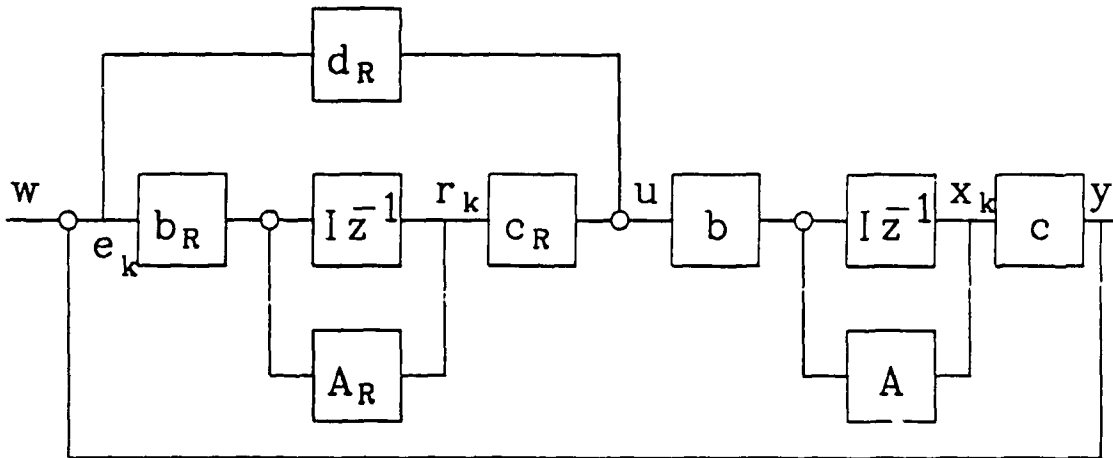

$$r[k+1] = A_R r[k] + b_R e[k]$$

$$x[k+1] = Ax[k] + bu[k]$$

$$u[k] = c_R r[k] + d_R e[k]$$

$$y[k] = cx[k]$$

Figure 5.2: State Space Depiction of the Plant with Compensator

meets all the specifications.

The first moderately acceptable equation occurred with a value of  $\zeta=1.0$ . The eigenvalues for this system were 4 poles at  $z=.8607$  and one pole at  $z=.01$  and the result is shown in Figure 5.3. The interval maintenance for this simulation is extremely good. The down side is that it takes substantial input to achieve this. A maximum input for 5 seconds is not desired from a fuel consumption standpoint. We therefore selected another, larger damping ratio for the desired equation. This equation had  $\zeta=1.3$  and two eigenvalues of  $z=.7820$ , two at  $.9473$ , and one at  $.01$ . These results are shown in Figure 5.4. This looks like an acceptable result. The interval is extremely well maintained and there is no clipping of the input. There is, however, a very quick jump in the input from the initial value to the approximate final value. This type of increase is difficult to implement in a physical system. Although this looks good, we wondered if we could do better, and in fact we did. We selected a desired equation with  $\zeta=1.5$  and two eigenvalues at  $z=.7697$ , two at  $.9625$ , and one at  $.01$ . This result is shown in Figure 5.5. This simulation has all the aspects we want in a 1 DOF semi-robotic convoy. The interval is very well maintained, the input is not clipped nor excessively applied, and there is no steady-state error.

### **5.5.3 The n-Vehicle Column**

Since series compensation appears to be an acceptable method of controlling a 1 DOF convoy, we must ensure that this method is capable of being applied to the n-vehicle model. The process we follow to derive the n-vehicle model is the same process we used for the three-vehicle column.

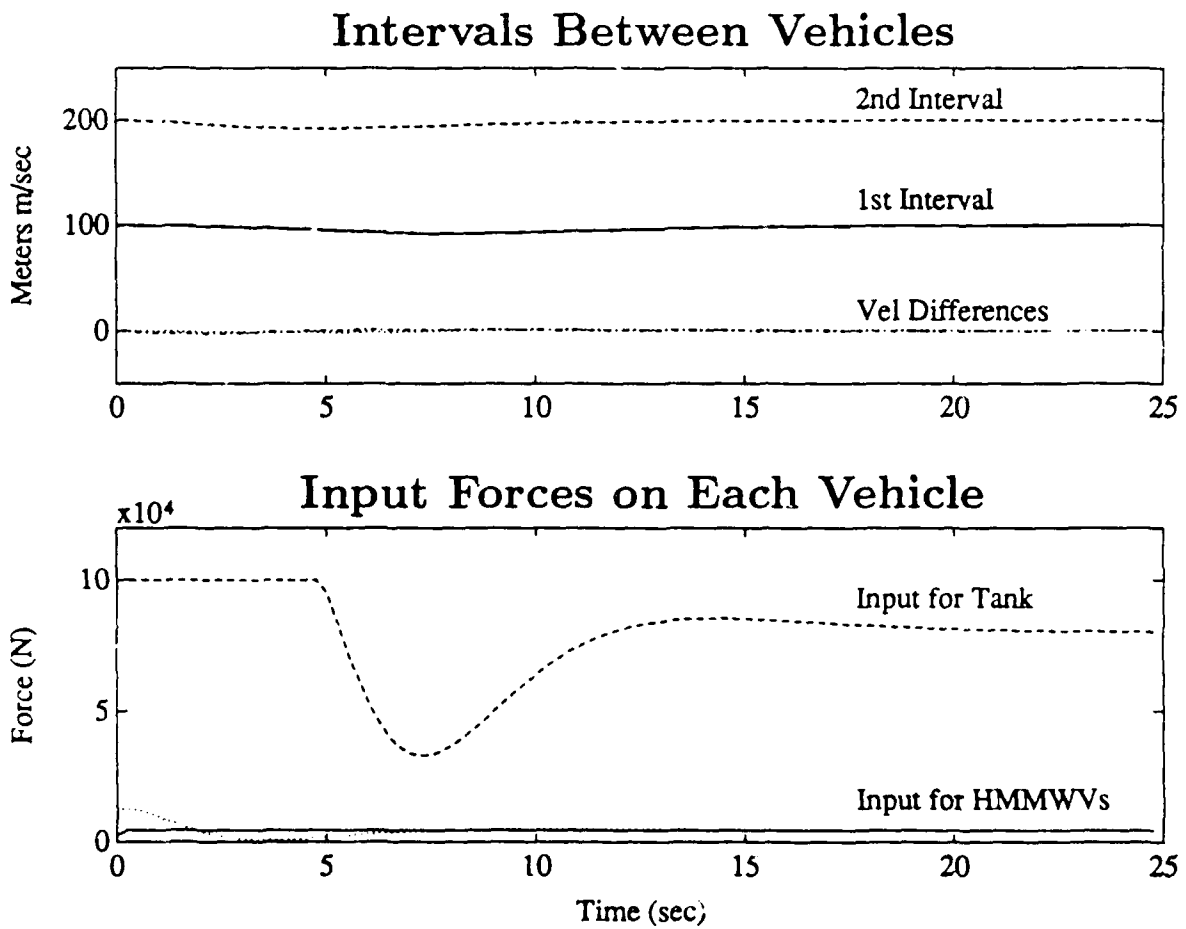

Figure 5.3: Series Compensation with  $\zeta = 1.0$

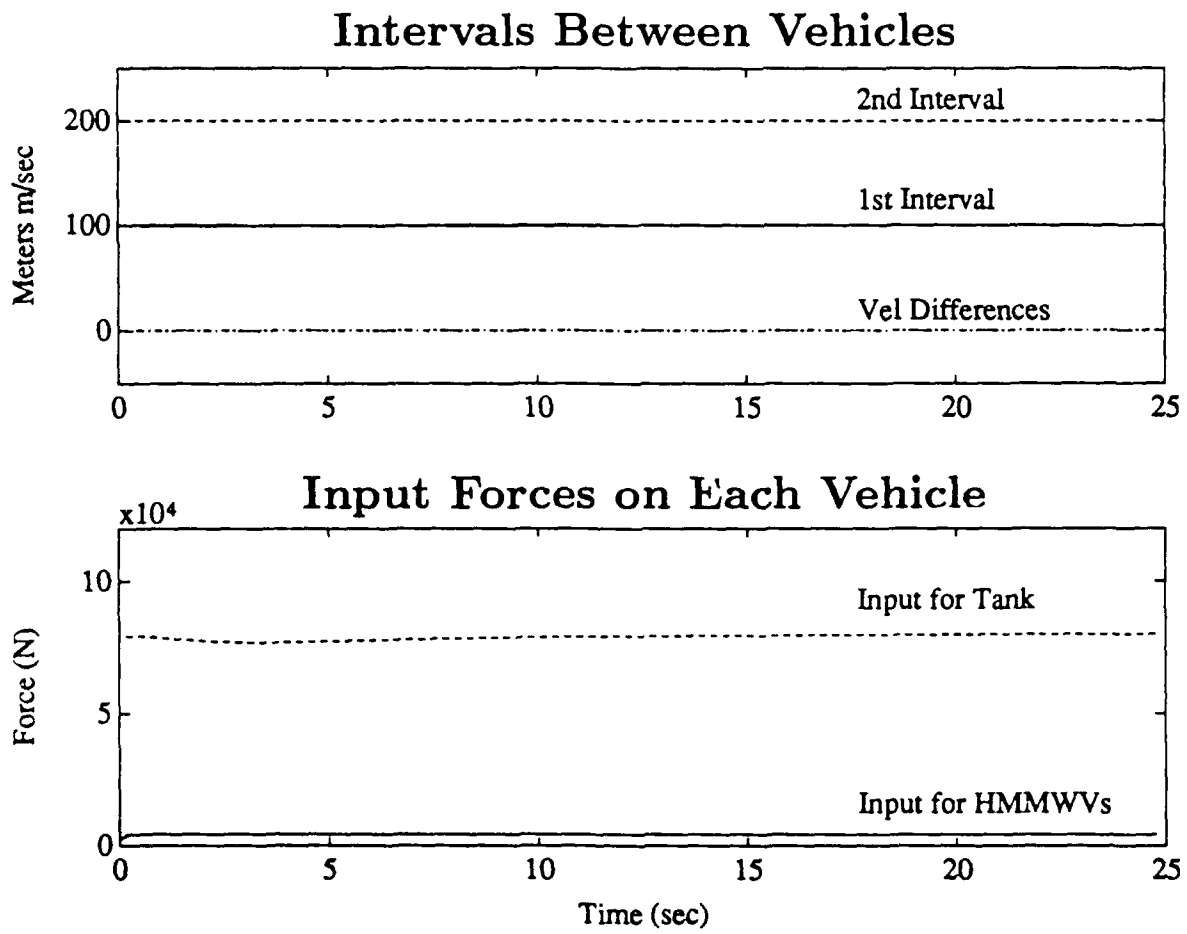

Figure 5.4: Series Compensation with  $\zeta = 1.3$

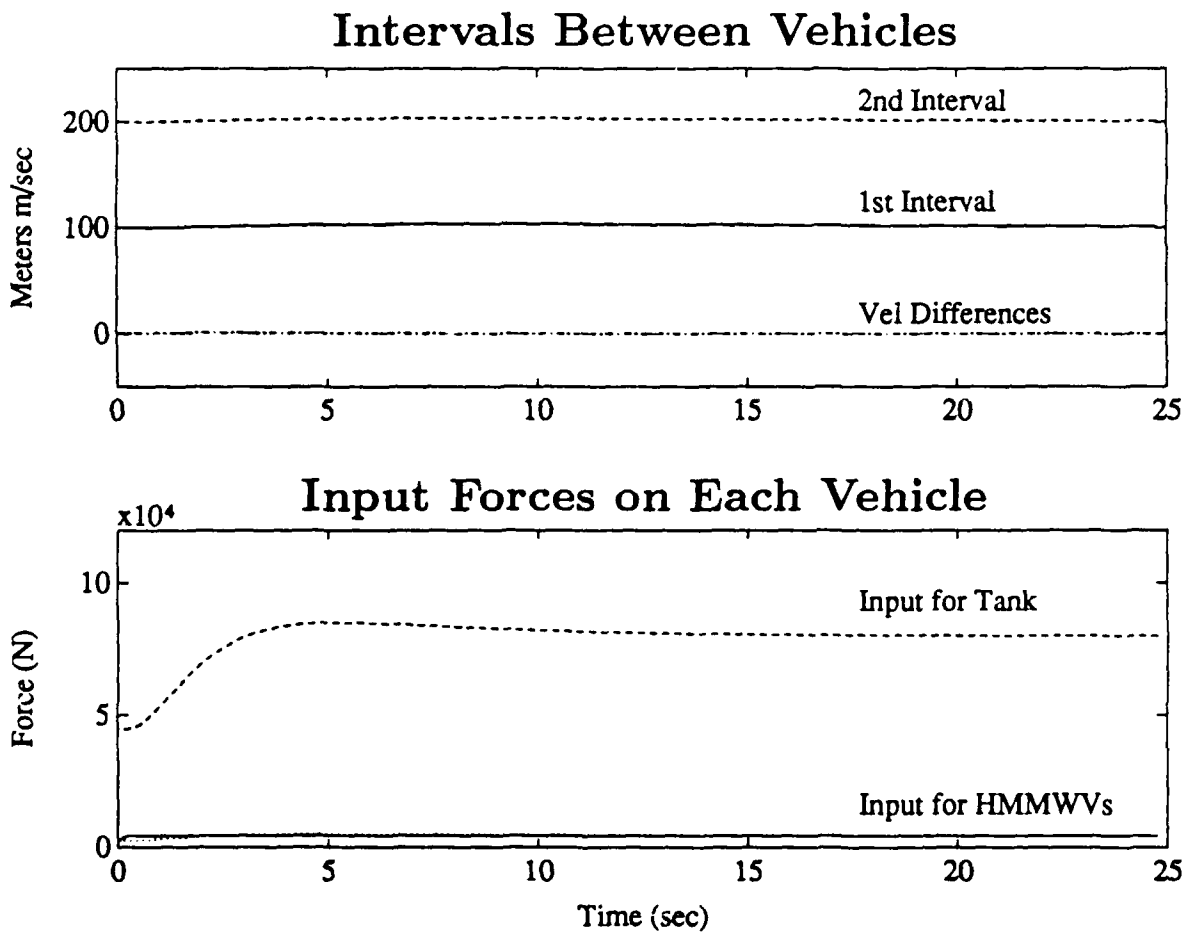

Figure 5.5: Series Compensation with  $\zeta = 1.5$

We begin by finding the the transfer function of each of the  $n$  vehicles. This can be accomplished using Equation 5.6. The next step is to build a compensator which can be added to the transfer function of each vehicle. Since we want each vehicle to have the same dynamics, each compensator will be designed so that when multiplied by the transfer function of the vehicle, each of the  $n$  vehicles will have the same characteristic equation. The  $n$ -vehicle solution with the series compensator is displayed graphically in Figure 5.6. This is very similar to Figure 5.2.  $H_1$  is the transfer function of the lead vehicle.  $d_i$  is the series compensator for the  $i$ th vehicle and  $x_i$  is the output, or position, of the  $i$ th vehicle.

## 5.6 Summary

In this chapter we explained series compensation and applied it to both a three-vehicle column and an  $n$ -vehicle column. The purpose of adding a series compensator to the semi-robotic convoy was to eliminate the steady-state error. As expected, the system worked very well and the error was removed. Additionally, after several iterations, we were able to find values for the compensators coefficients which produced excellent system performance. There were no indications that this technique could not be successfully applied to any vehicle in any application of the semi-robotic convoy. With this in hand, we feel confident that we can solve any 1 DOF semi-robotic convoy problem. We can now turn our attention to solving the two degree-of-freedom problem.

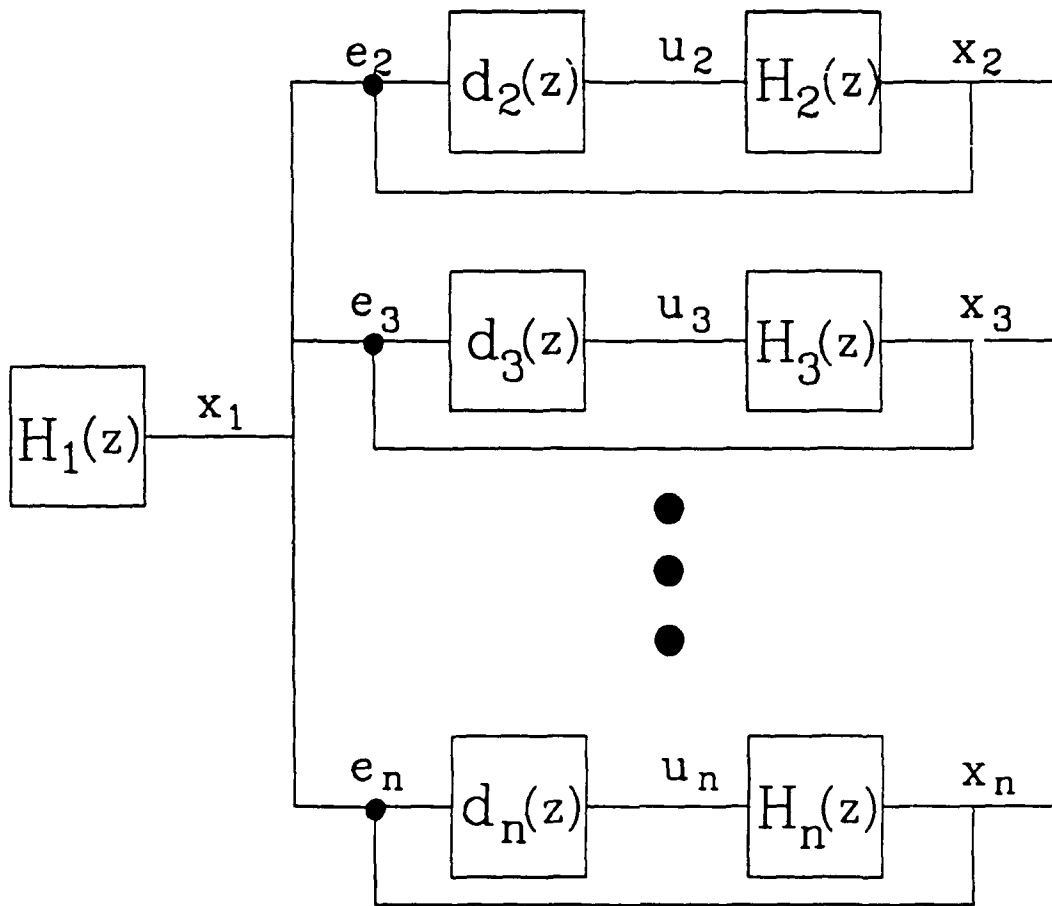

Figure 5.6: Series Compensation of  $n$ -Vehicles

# Chapter 6

## Solving the Two Degree-of-Freedom Problem

### 6.1 Introduction

We are now confident that we are capable of controlling a 1 DOF convoy while meeting all specifications, including the desired steady-state error. Unfortunately, real convoys travel in two dimensions. Even though the vehicles can move up and down hills in three dimensional space, the movement is confined to the surface of the ground. Since each point on the ground can be described by a two-dimensional set of coordinates, this is really a two-dimensional problem. Therefore, the new problem is to use what we have already learned to help derive a strategy to control these unmanned trail vehicles as they travel in an arbitrary two-dimensional path. This control must be accomplished while still meeting the performance specifications for steady-state error in both interval maintenance and lateral error maintenance.

This chapter attempts to develop that control strategy. We begin by defining this 2 DOF problem. Specifically, how is it different than the 1 DOF problem? We also examine some subtleties of the problem which must be addressed before a solution



can be derived. With the problem well defined, we then move to design a control strategy which will control the 2 DOF convoy within the specifications. The chapter concludes with the simulations from our three-vehicle example which should confirm our previous findings.

## **6.2 Problem Definition**

Before attempting to design a control strategy for the 2 DOF convoy, it is first necessary to completely understand the problem. We begin with a short description of the 2 degrees of freedom necessary to describe the system. We then compare this system to the 1 DOF system. We conclude this section with an examination of some specific requirements which could impact on the performance of the convoy. The end result will be a thorough understanding of the 2 DOF problem.

### **6.2.1 Defining the Two Degrees-of-Freedom**

What is meant by saying a system has two degrees-of-freedom? This terminology is used to describe motion which occurs in two directions. If we think of the ground over which the convoy will travel as an  $x,y$  grid, the movements of any vehicle has two components. It moves some distance in the  $x$  direction and some distance in the  $y$  direction. To accurately define the position of the vehicle, we need to know about both components. This information can take one of two forms. The  $x,y$  description tells the  $x$  and  $y$  component of the state directly. The polar description of the state uses a vector description, which requires the  $x$  and  $y$  components to be calculated. The magnitude of this vector is the distance travelled by the vehicle. Both of these descriptions will be used to help solve the 2 DOF problem.

### 6.2.2 Comparison of the 1 and 2 DOF Problems

If we use a polar description of the 2 DOF system, there is virtually no difference between the 1 and 2 DOF convoys. The similarity lies in the fact that each shares a similar degree of freedom, the total distance travelled. In the 1 DOF system, this was simply referred to as position. The problem was defined such that the vehicles began at a position of zero, and then travelled to some position, which was the total distance travelled. The 2 DOF problem is set up basically in the same manner. The difference is that the distance travelled by the 2 DOF system is a vector with both an x-component and a y-component. If we deal with the angle of the vector separately, the two problems are identical. The magnitude of the 2 DOF vector is the same as the distance travelled by the 1 DOF system. An example will help explain this concept.

Assume a vehicle in a 1 DOF system starts at zero and travels 1 meter during a time step. The distance travelled by that vehicle is simply 1 and the position is therefore 1. If the same vehicle travels 1 meter in a 2 DOF system, the distance travelled is still 1, however the position of the vehicle has both an x and y component. The difference between the two systems is that to calculate the position of the 2 DOF system, we must know the angle of the vector. We can then calculate the x and y position of the vehicle. This example shows that we can treat the 2 DOF system exactly like a 1 DOF system, until we want to determine the x,y position of the vehicle. Then we must include the second dimension, the angle of the vehicle.

### 6.2.3 Additional Requirements of the 2 DOF System

From the above discussion, we understand the relationship between the 1 and 2 DOF systems. The 2 DOF system has the added requirement of knowing the angle of the vehicle. How can this be determined? Section 2.3.3 describes the sensors used in the semi-robotic convoy. The sensors for the Leader-Follower approach provide an x,y position of the vehicle. If we know the x,y position of a vehicle at one time and then again at another time, the angle between the two points is simply the arc tangent of the difference of the y's divided by differences of the x's.

The 2 DOF has another, more subtle, requirement. The ideal solution of the 2 DOF problem would have the trail vehicle navigating to the exact same points that the lead vehicle did. This, however, must be accomplished while the trail vehicle maintains the proper interval behind the lead vehicle. This interval is measured along the path travelled by the lead vehicle. The control law derived for the 1 DOF system, Equation 4.5, is still applicable for the 2 DOF system. In other words, the control law ensures when the lead vehicle has travelled a given distance, the trail vehicle will have travelled that same distance minus the specified interval. Unfortunately, the distance travelled by the trail vehicle may or may not be on the same path as the lead vehicle. To ensure the trail vehicle follows the same path as the lead vehicle, we must add some additional control to the system. This control must ensure that the trail vehicle has the same angle the lead vehicle had when the lead vehicle was at that point.

This additional control can be accomplished by maintaining a table, in memory, of the x,y position and velocity profiles of the lead vehicle. This table will include the

distance travelled, the corresponding angle and each x and y component at each sampling instance. The trail vehicle then uses this information as a look-up table. The trail vehicle knows its current location and how far behind the lead vehicle it should be located, it then locates the appropriate data from the table and then calculates its new angle to navigate to that point. If the data points are sufficiently close together, the result is a smooth replication of the lead vehicles path by the trail vehicle.

### 6.3 Solving the 2 DOF Problem

Now that we fully understand the 2 DOF system, we can begin to develop a control law for the column. We showed in the previous section, that we can still utilize the same control law we used to solve the 1 DOF problem. To solve the two degree-of-freedom we need to develop a technique for the trail vehicle to find the appropriate data from the lead vehicle so that the correct angle can be calculated. At first glance, this seems to be a trivial problem. Knowing the historical profile of the lead vehicle, the trail vehicle simply subtracts the required interval and then picks off the appropriate information. In practice, this problem is somewhat more difficult.

As the lead vehicle traverses a path, the data of distance travelled, angle, and x and y components are recorded at each sampling instance. The trail vehicle needs to find the appropriate information from this table. If the lead vehicle were travelling at a constant velocity, the task would be very simple. At constant velocity, there would be a fixed number of time steps between the position of the lead and the position of the trail vehicle. The trail vehicle would only need look that many time

steps back of the lead vehicle's profile and pick off the corresponding angle. If the lead vehicle is not travelling at a constant velocity, which is normally the case, the problem becomes somewhat more complex. I will use an example to explain.

Assume the lead vehicle is travelling at 20 meters/second, the second vehicle is following at 100 meters, and we are sampling every .25 seconds. It would take the lead vehicle 5 seconds to travel the 100m, which corresponds to 20 sampling instances. For the trail vehicle to find the angle of the lead vehicle at the trail vehicle's current location, it would simply count back 20 sets of data and take that corresponding information. If, however, the lead vehicle were travelling at only 10 meters/second, it would take 10 seconds to cover the same ground. This time the trail vehicle would have to look back 40 sets of data to determine the correct information. Obviously, a search algorithm needs to be developed so the trail vehicle can accurately locate the proper information.

### **6.3.1 Developing a Search Algorithm for the Trail Vehicle**

There are numerous possible search algorithms which could be developed to solve this problem. The routine described here was used because of its ease of application to the existing simulation used for the 1 DOF system. We first simulate the lead vehicle. This simulation produces the historical profile of the lead vehicle in the form of a matrix which will be utilized by the trail vehicle to determine its correct angle. This matrix has columns containing the x-position, the y-position, distance travelled during that time step, the cumulative distance travelled, and the angle of the vehicle. The rows of the matrix represent this information for each time step.

The search routine is simply a loop containing two "if" statements. The loop is used to search through the entire matrix of information. The two "if" statements are used to bracket the appropriate information. The first "if" checks to see if k'th entry of the total distance travelled is less current distance travelled by the trail vehicle. The second "if" checks to see if the k-2 entry of the total distance travelled is greater than the current distance travelled by the trail vehicle. If both these statements are true, then the k-1 entry is selected as the appropriate data. The x and y positions are then used to calculate the angle necessary for the trail vehicle to navigate to that point on the lead vehicle's path. This routine is shown in flow chart form in Figure 6.1.

This search routine makes use of two assumptions, in addition to those assumptions outlined in Section 2.2.

1. The dynamics involved in the vehicle's steering system are negligible and do not impact on the vehicle's performance.
2. The vehicle can instantaneously orient in the proper orientation.

These assumptions are not extremely realistic. But they allow us to analyze this semi-robotic convoy concept with a workable model to see if the implementation is possible in ideal conditions.

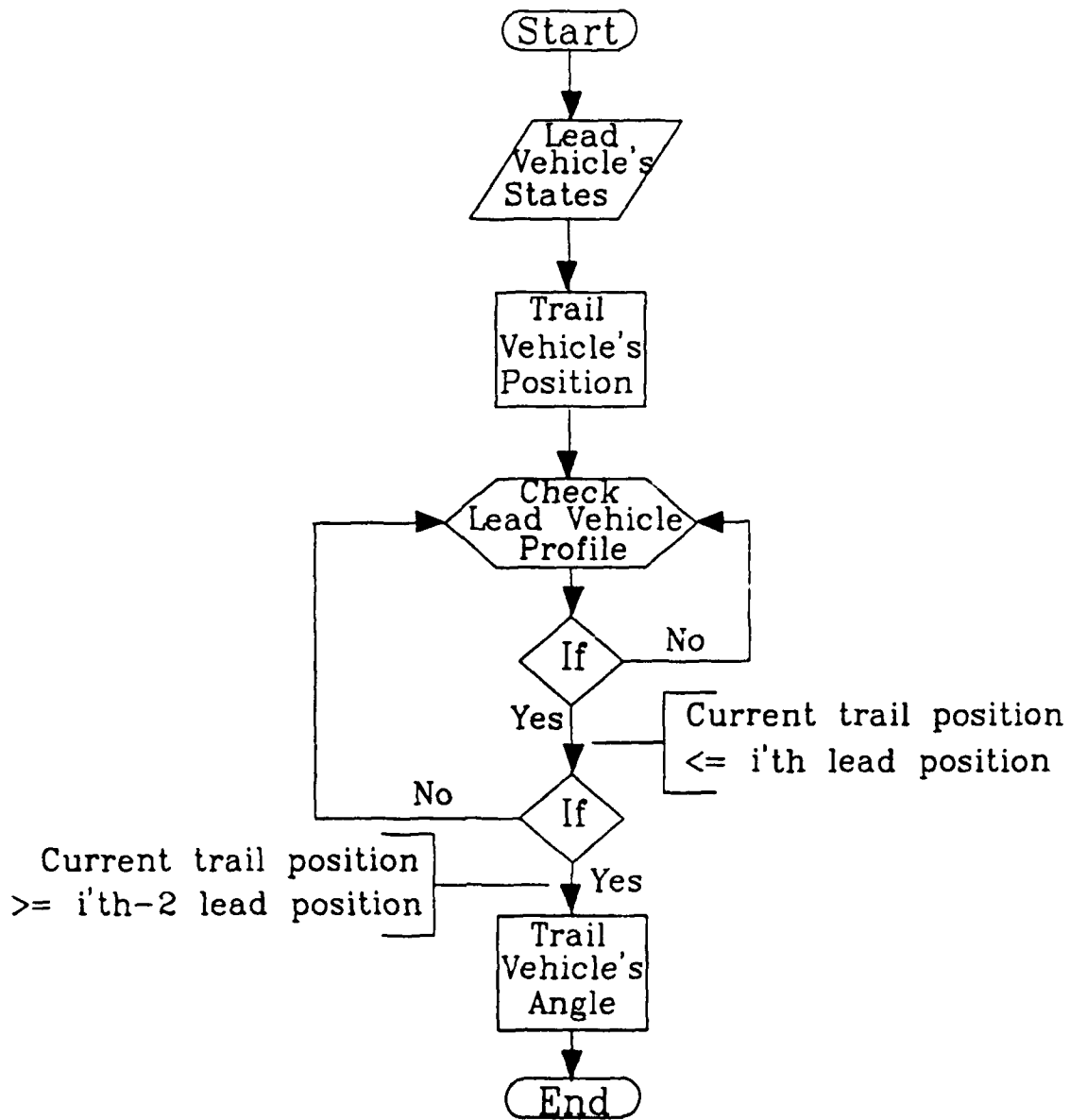

Figure 6.1: Flow Chart of Search Routine

## 6.4 Simulation of the 2 DOF System

We now want to verify that the control law proposed in the previous section is valid. Again, we will use the simulation of the three vehicle column. The simulation for the 2 DOF system utilizes the same MATLAB simulation used for the 1 DOF system. To this simulation, we added the search algorithm derived in the previous section. Additionally, we modified the simulation of the lead vehicle to produce the 2 DOF movements. In each simulation, the angle, like the input, of the lead vehicle is arbitrarily determined. We want to see how well the trail vehicles follow the lead vehicle. All simulations begin with the column at the proper interval and a steady-state a velocity of 9.16 meters/sec (20 mph). The first simulation uses a continuously changing angle of the lead vehicle and a constant velocity. The lead vehicle begins at 45 degrees, the angle is incremented by one degree during each of the 300 time steps. The top graph of Figure 6.2 shows the plot of each vehicle in the x,y plane. The bottom graph shows the interval between first and second and first and third vehicles. It is obvious from this that the system performed exactly as anticipated.

Figure 6.3 and Figure 6.4 show the result of the second simulation. This simulation uses the same information as the first, except here, the angle to the lead vehicle is changed at three different times. This simulation also varies the input which causes changes in the vehicle velocities. Figure 6.3 shows the x,y position of the vehicles and the intervals of the system. Figure 6.4 shows the input of the vehicles versus time and the velocities of the vehicles versus time. Here again, the system performs as expected. The only deviations are with the interval. The changes of the inter-



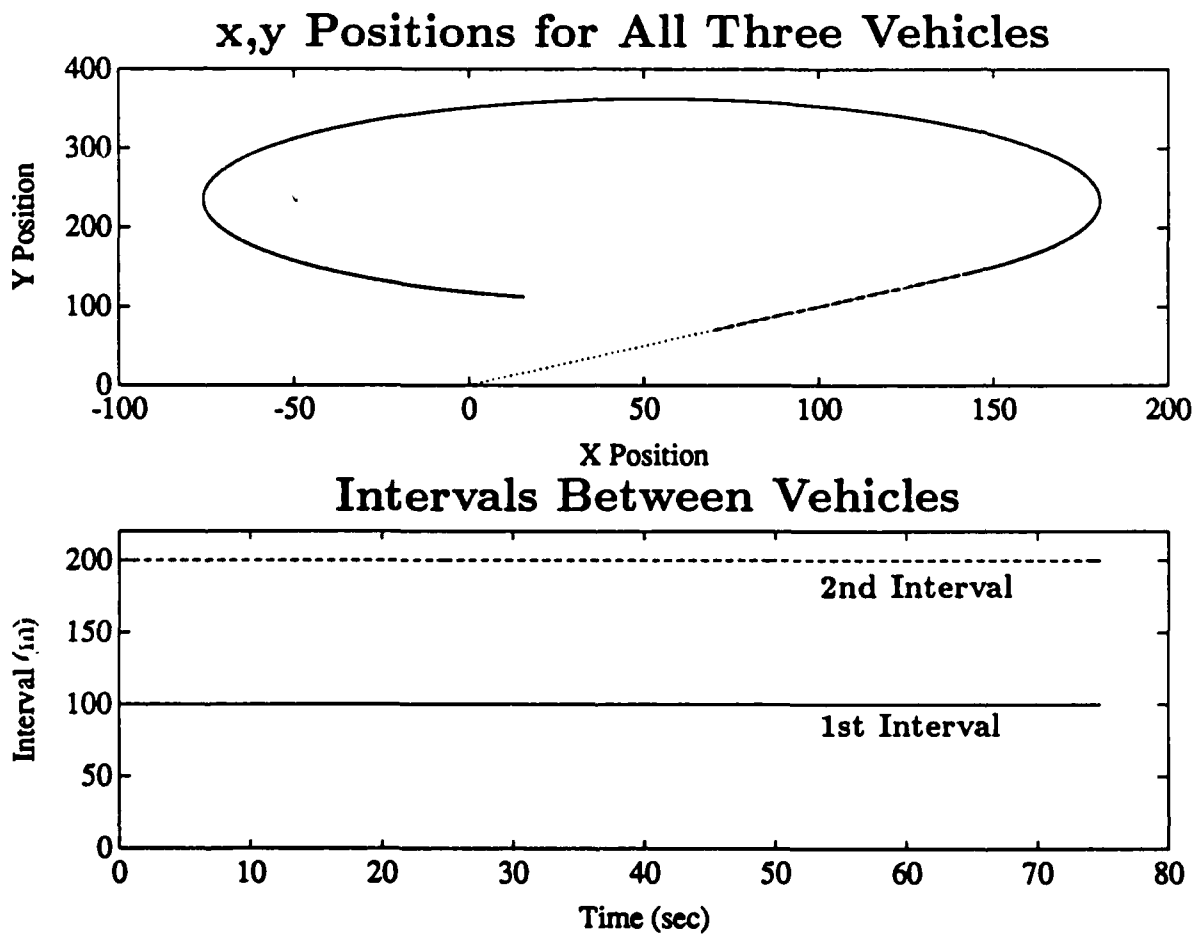

Figure 6.2: 2 DOF Simulation with Variable Angle and Constant Velocity

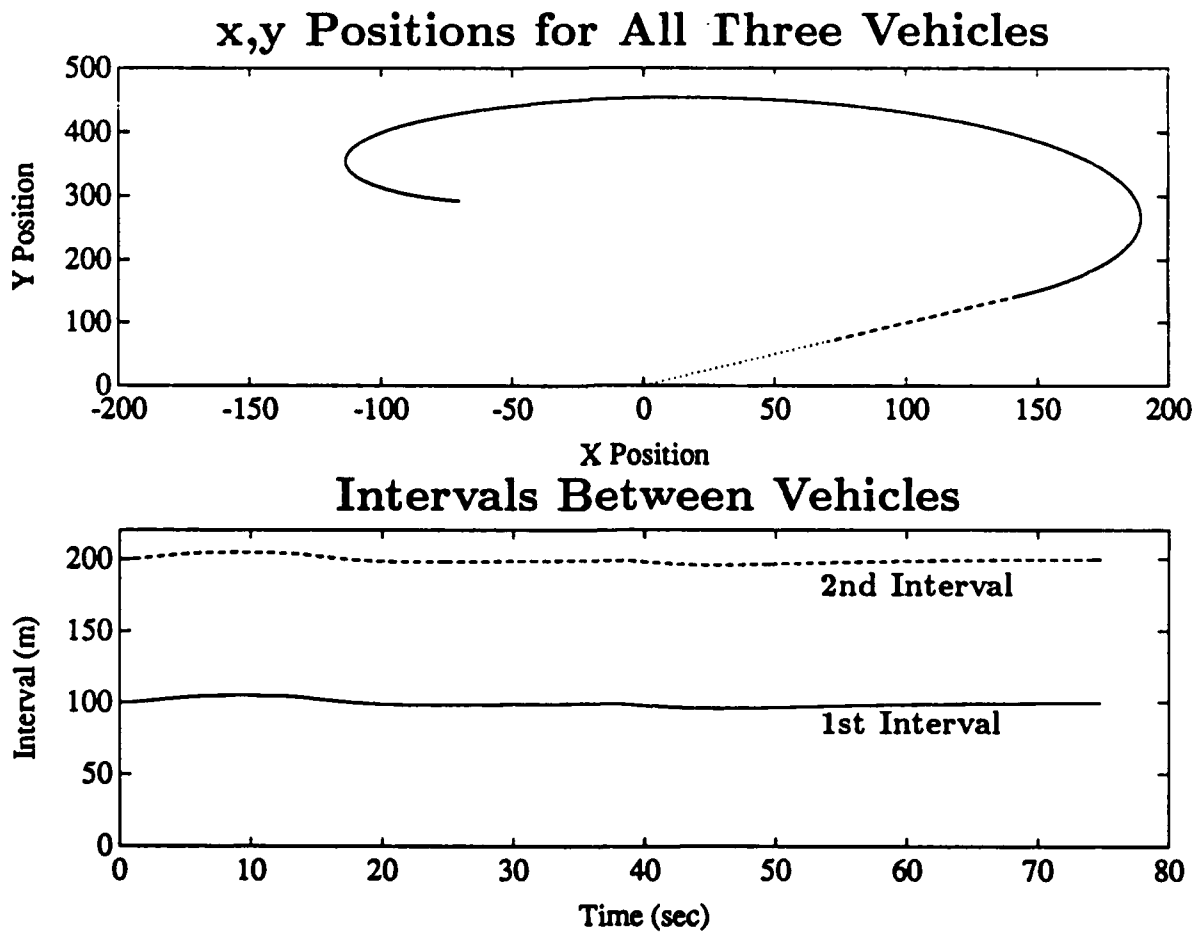

Figure 6.3: 2 DOF Simulation with both Variable Angles and Velocities

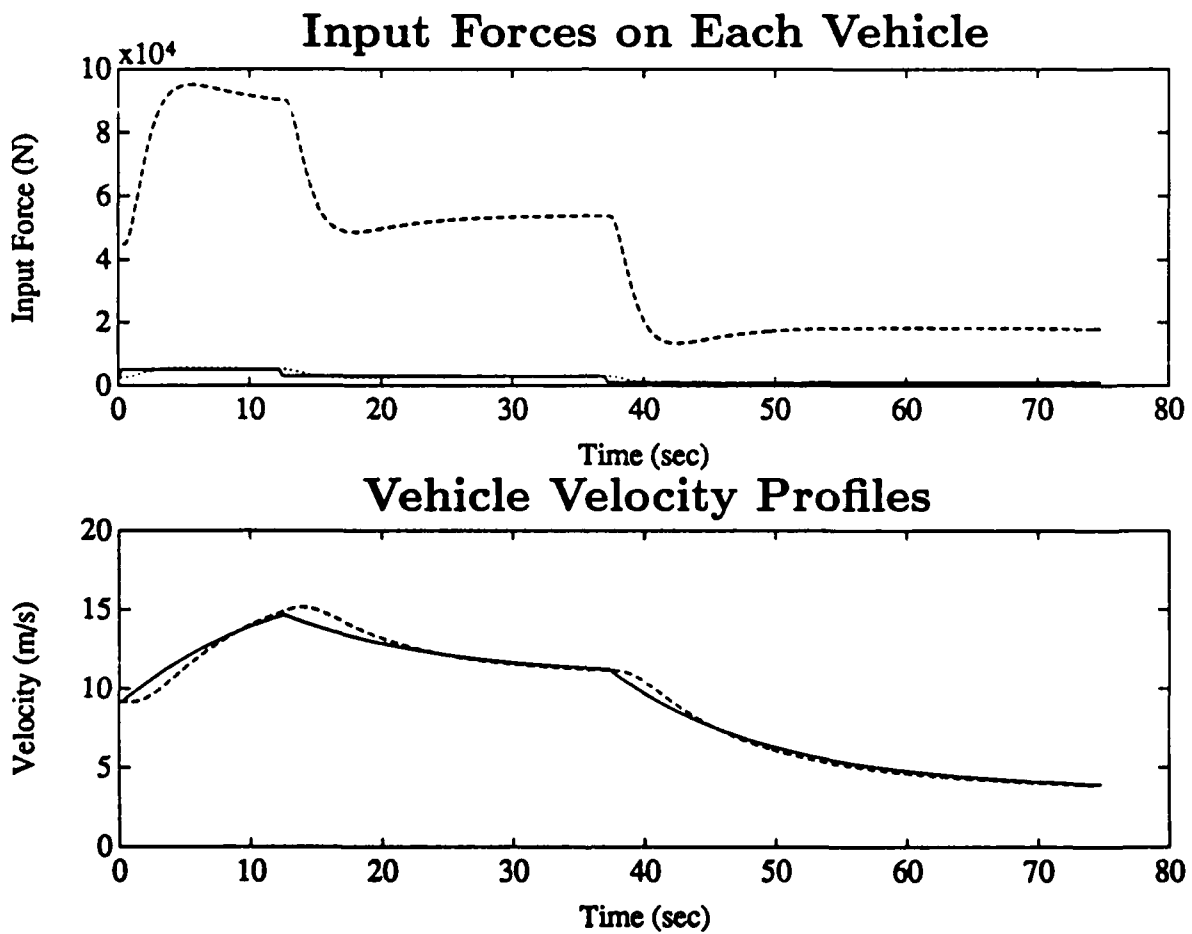

Figure 6.4: 2 DOF Simulation with Variable Velocities and Dramatic Variations of Angles

val are due to instantaneous change in input for the lead vehicle where as the trail vehicles input is gradually changed. These interval deviations fall within the 20% specification so there is no danger of collisions during the transient response of the system. Therefore, the system performs in an acceptable manner.

Figure 6.5 shows the result of the third, and final, simulation. Since we use the same changes in the lead vehicle's input as we did in the second simulation, the input forces and velocity profiles are the same as they were in Figure 6.4. In this simulation, however, the angle of the lead vehicle is dramatically changed at three different times. Again, with the exception of the fluctuations in the intervals the system performs remarkably well.

These three simulations verify our initial findings about the 2 DOF system. The control law derived for the 1 DOF system is also applicable to the 2 DOF system. This controls the interval of the trail vehicles along the path of the lead vehicle. The orientation of the trail vehicles was determined in two steps. First, a search algorithm finds the x,y coordinates of the path at the appropriate interval behind the lead vehicle. Second, the trail vehicle calculates its correct angle to navigate to that x,y location. This new control law meets the specifications of the system.

## **6.5 2 DOF Solution for n-Vehicles**

In the previous discussions of the n-vehicle problem, the solution was found by simply expanding the three-vehicle model to n vehicles. This same methodology applies to the 2 DOF system. As with the three-vehicle column, each of the n

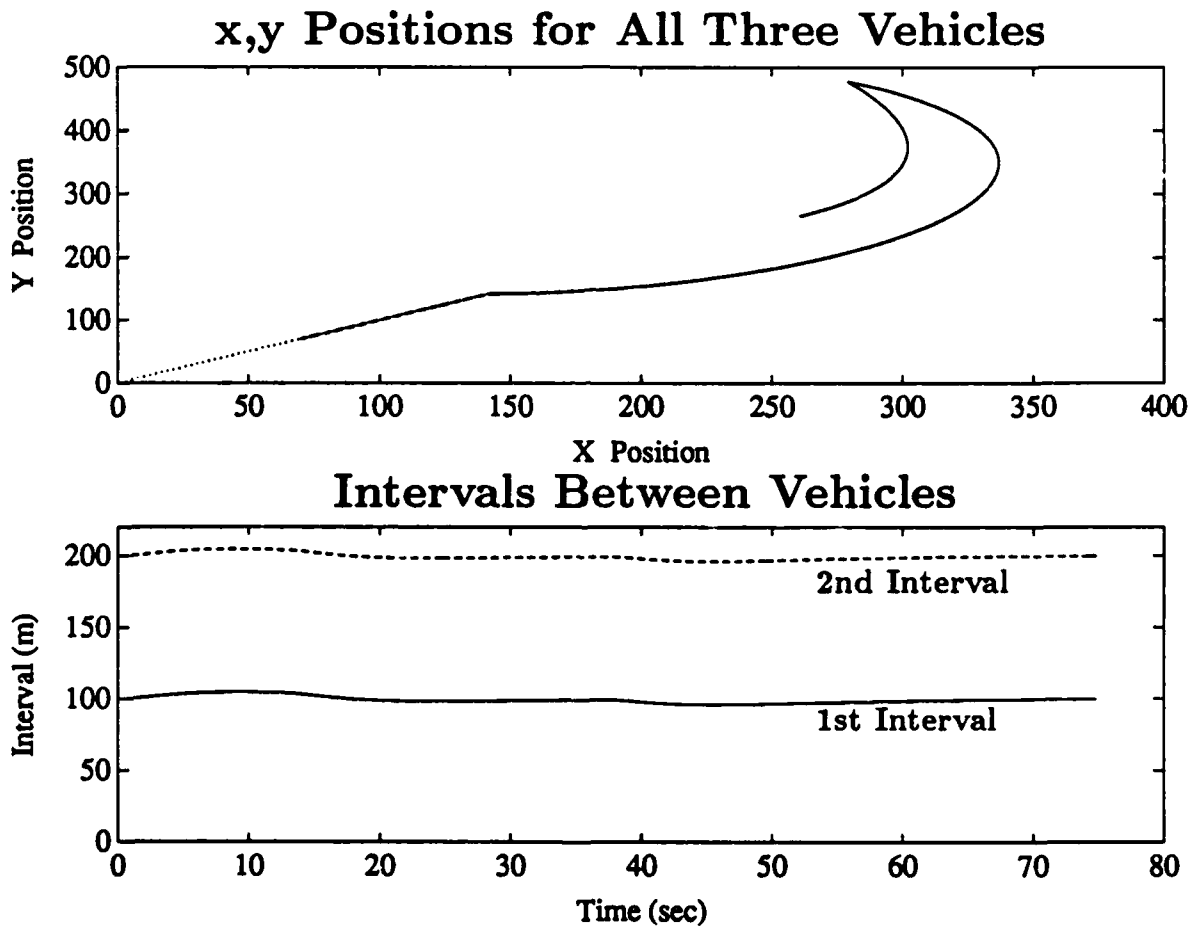

Figure 6.5: 2 DOF Simulation with Variable Velocities and Dramatic Variations of Angles

vehicles in the column is equipped with the search algorithm. When the convoy commander specifies each vehicle's position in the column, the required interval behind the lead vehicle is also provided. Each vehicle then conducts its own search routine through the position profile of the lead vehicle and independently determines its correct orientation.

## **6.6 Summary**

In this chapter, we completely defined the 2 DOF problem. From this definition, we derived a control law so the trail vehicle would follow the path of the lead vehicle while still maintaining the correct interval between vehicles. This control law was a combination of the one used in the 1 DOF system and a routine to determine the appropriate angle. The chapter concludes with a simulation of a three-vehicle column with the new control law applied. The result was a column that followed the lead vehicle well within the system specifications. We concluded that this control law meets the major objective of this thesis. The chapter concludes with a description of the 2 DOF solution for an n-vehicle column.

# Chapter 7

## Conclusions and Recommendations

### 7.1 Conclusions

The purpose of this thesis was to determine if a generic control law could be derived which would allow the implementation of a semi-robotic convoy. We began by first developing the equations of motion for a single vehicle using Newton's Second Law. Two methods were discussed to tie together the vehicle models into a convoy model. We then derived a relationship to ensure that both methods were valid. This one degree-of-freedom convoy model was then applied to actual military vehicles. We constructed a three-vehicle convoy simulation consisting of two High Mobility Multi-Purpose Wheeled Vehicles and one M1 Abrams Main Battle Tank.

To facilitate in the analysis, we examined how to model the convoy as a sampled-data system. We developed a method for selecting a time sampling interval tailored to the needs of this semi-robotic convoy. Using MATLAB, a digital simulation was developed for the column.

Next, we determined that our objective was possible because the convoy was indeed capable of being controlled. With this knowledge, we studied state-feedback control. A 1 DOF state-feedback control law was developed which ensured that each trail vehicle followed the lead vehicle at a specified interval. This control law was then applied to the sampled-data system. The simulation showed that there was a trade-off between reducing the steady-state error and reducing the oscillations in the control force. Even though we were able to obtain a set of feedback gains which produced acceptable performance, we determined that this method of control was unacceptable because of the steady-state error.

We then studied a different technique of 1 DOF control, series compensation. The implementation of a series compensator allowed us to eliminate the steady-state error from the system while still producing acceptable system performance. A simulation of the three-vehicle column verified these conclusions.

With a solution in hand for the 1 DOF system, we then turned our attention to solving the 2 DOF problem. We began this task by completely defining the 2 DOF system. We found that the results from the 1 DOF problem could also be applied here. Additionally, if we stored the position profile of the lead vehicle, the trail vehicle could determine its proper orientation by utilizing a search routine and a simple calculation. We combined the 1 DOF solution with the search routine and calculation to produce a 2 DOF control law for the semi-robotic convoy. Simulations of this system again verified our conclusions; the two trail vehicles followed the lead vehicles path (x,y position profile) well within the system specifications.



Overall, series compensation allows the intervals within the column to be controlled with no steady-state error. The x,y position of the vehicles can be controlled by storing the position profile of the lead vehicle and utilizing a search routine so the trail vehicle is capable of determining its proper orientation. This 2 DOF control law results in performance which meets all system specifications. Additionally, by first deriving the control law theory, then verifying it with a simulation, and then deriving a solution for the n-vehicle column, we ensured this system was applicable to a wide variety of any number of vehicles.

## 7.2 Recommendations

There are numerous areas for future research. Developing a more realistic vehicle model is the most obvious need. The model should be expanded to incorporate the internal dynamics of the vehicle as well as realistic modeling of all the friction forces.

Research into various types of sensors is another area of concern. The accuracy and precision of the sensors will obviously have a significant impact on the performance of any fielded system.

Finally, regardless of the sensors selected, a method needs to be developed which handles collision avoidance. The column must be capable of handling unforeseen occurrences. Examples of these occurrences include vehicle breakdowns within the column and animals or individuals walking between trailing vehicles during operation.

# List Of References

1. Ackermann, J., Sampled-Data Control Systems, Springer-Verlag, Berlin, Heidelberg, 1985.
2. Ananda, M.P., H. Bernstein, K.E. Cunningham, W.A. Feess, and E.G. Stroud, "Global Positioning System (GPS) Autonomous Navigation," IEEE Position Location and Navigation Symposium, 1990, pp. 497-508.
3. Cahlon, B., "Safe Solution of a Car-Following Problem," Journal of Mathematical Analysis and Applications, 81 134-155, 1981.
4. Caudill, R.J. and W.L. Garrard, "Vehicle Follower Longitudinal Control for Automated Transit Vehicles," Journal of Dynamic Systems, Measurement, and Control, 241-248, 1977.
5. Caudill, R.J. and S.L. Blasnik, "Model Reference Longitudinal Control for Automated Vehicle Systems," Journal of Dynamic Systems, Measurement, and Control, 102, 77-84, 1980.
6. Caudill, R.J., P. Di Matteo, and S.P. Thomas, "Longitudinal Control for Automated Highway Vehicles," Journal of Dynamic Systems, Measurement, and Control, 104 180-187, 1982.
7. Cormier, W.H. and R.E. Fenton, "On the Steering of Automated Vehicles - A Velocity-Adaptive Controller," IEEE Transactions on Vehicular Technology, VT-31(1) pp. 32-39, 1982.
8. Fenton, R.E., "A Headway Safety Policy for Automated Highway Operations," IEEE Transactions on Vehicular Technology, VT-28(1) 22-28, 1979.
9. Fenton, R.E. "Automatic Vehicle Guidance and Control - A State of the Art Survey," IEEE Transactions on Vehicular Technology, VT-19(1) pp. 153-161, 1970.

10. Fuentes, A. F. LT, "Loran-C in the 21st Century," IEEE Position Location and Navigation Symposium, 1986, pp. 277-279.
11. Gray, C.M., K.D. Rehm, and D.R. Woods, "The Drone Formation Control System," IBM Technical Directions, Federal Systems Division, Vol. 9, No. 1, 1983.
12. Hale, F.J., Introduction to Control System Analysis and Design, 2nd Ed., Prentice Hall Inc., New Jersey, 1988.
13. Harmon, S.Y., "The Ground Surveillance Robot (GSR): An Autonomous Vehicle Designed to Transit Unknown Terrain," IEEE Journal of Robotics and Automation, RA-3(3) PP. 266-279, 1987.
14. Kaufman, A., "Continuous Simulation of a Car-Following Equation," Mathematics and Computers in Simulation XXIV, North Holland Publishing Co., 88-94, 1982.
15. Mayhan, R.J. and R.E. Fenton, "A Two-Frequency Radar for Vehicle Automatic Lateral Control," IEEE Transactions on Vehicular Technology, VT-31(1), pp. 32-39, 1982.
16. Mayhan, R.J., "Improving the Performance of a Two-Frequency Radar for Vehicle Automatic Lateral Control," IEEE Transactions on Vehicular Technology Conference, pp. 474-479, May 1982.
17. Ogata, K., Modern Control Engineering, 2nd Ed., Prentice Hall Inc., New Jersey, 1990.
18. O'Halloran, W.F. and B.J. Uttam, "Applications of LORAN-C to Land Navigation," IEEE Position Location and Navigation, pp. 345-349, 1980.
19. Olson, K.W., E.R. Sapp, and T.L. Flaig, "A System for Automatic Vehicle Lateral Guidance," Highway Research Record 275, pp. 1-11, 1969).
20. Parkinson, B.W., "Navstar Global Positioning System (GPS)," Proceedings of the National Telecommunications Conference, (III) pp. 41.1-1 through 41.1-5.
21. Peppard, L.E. and V. Gourishanker, "An Optimal Automatic Car-Following System," IEEE Transactions on Vehicular Technology, VT-21(2) 67-73, 1972.

22. Pletta, J.B., "Feasibility Study for an Attachable Robotic Convoy Capability (ARCC) System," Sandia Report SAND87-2595, Sandia National Laboratories, Albuquerque, New Mexico, December 1987.
23. Stokes, K.W., "Remote Control Target Vehicles for Operational Testing," Kaman Sciences Corporation, Colorado Springs, Colorado, 1989.
24. Stokes, K.W. and J.M. Rapkoch II, "Near Term Applications of the Radio Frequency Navigational Grid Vehicle Control System," Kaman Sciences Corporation, Colorado Springs, Colorado, 1988.
25. United States Army, "Draft - Robotics Master Plan," Headquarters, Department of the Army, Washington, D.C., 1989.
26. United States Army, FM 7-7J The Mechanized Infantry Platoon and Squad (Bradley), Headquarters, Department of the Army, February 1986.
27. United States Army, TM 9-2320-280-10 w/ Changes 1&2, Operator's Manual for Truck, Utility: Cargo/Troop Carrier, 1 1/4 Ton, 4X4, M998, April 1985.
28. United States Army, TM 9-2350-255-10, Operator's Manual for Tank, Combat, Full-Track, M1 General Abrams, December 1990.
29. United States Military Academy, "OE 481- Automotive Engineering, AY 80-81," Department of Engineering, West Point, New York, 1980.

# VITA

The author received his Bachelors of Science with an Area of Concentration in Mechanical Engineering from the United States Military Academy at West Point in May 1981. Commissioned in the United States Army as an Armor Officer, he has served in a variety of positions including Platoon Leader, Executive Officer, and Cavalry Troop Commander. [REDACTED]

[REDACTED] The writing of this thesis concludes a Master of Science in Mechanical Engineering (Robotics) program started in August of 1990. After attending the Material Acquisition Manager's Course in March, 1991 he will be assigned as a Mission Control Specialist on the Kwajalein Atoll in the Marshall islands.

*A.T. Economy III*

A.T. Economy III