

DIGITAL COPY

1

AD-A231 443 SSC-337
(PART 2)

SHIP FRACTURE MECHANISMS

**A NON-EXPERT'S GUIDE FOR
INSPECTING AND DETERMINING THE CAUSES OF
SIGNIFICANT SHIP FRACTURES**

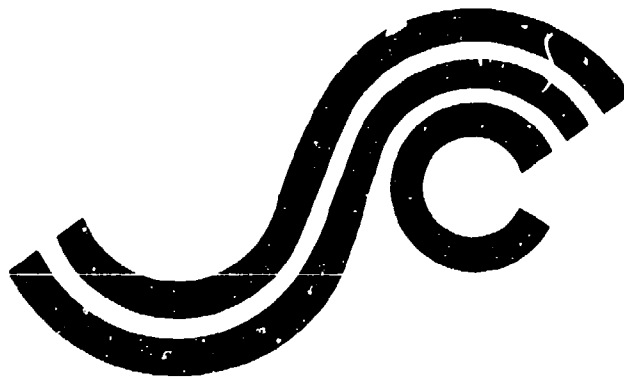

S DTIC
ELECTE
FEB 04 1991
E D

This document has been approved
for public release and sale, its
distribution is unlimited

SHIP STRUCTURE COMMITTEE
1990

91 2 01 049

SHIP STRUCTURE COMMITTEE

The SHIP STRUCTURE COMMITTEE is constituted to prosecute a research program to improve the hull structures of ships and other marine structures by an extension of knowledge pertaining to design, materials, and methods of construction.

RADM J. D. Sipes, USCG, (Chairman)
Chief, Office of Marine Safety, Security
and Environmental Protection
U. S. Coast Guard

Mr. Alexander Malakhoff
Director, Structural Integrity
Subgroup (SEA 55Y)
Naval Sea Systems Command

Dr. Donald Liu
Senior Vice President
American Bureau of Shipping

Mr. H. T. Haller
Associate Administrator for Ship-
building and Ship Operations
Maritime Administration

Mr. Thomas W. Allen
Engineering Officer (N7)
Military Sealift Command

CDR Michael K. Parrillee, USCG,
Secretary, Ship Structure Committee
U. S. Coast Guard

CONTRACTING OFFICER TECHNICAL REPRESENTATIVES

Mr. William J. Siekierka
SEA 55Y3
Naval Sea Systems Command

Mr. Greg D. Woods
SEA 55Y3
Naval Sea Systems Command

SHIP STRUCTURE SUBCOMMITTEE

The SHIP STRUCTURE SUBCOMMITTEE acts for the Ship Structure Committee on technical matters by providing technical coordination for determining the goals and objectives of the program and by evaluating and interpreting the results in terms of structural design, construction, and operation.

AMERICAN BUREAU OF SHIPPING

Mr. Stephen G. Aintson (Chairman)
Mr. John F. Conlon
Mr. William Hanzalek
Mr. Philip G. Rynn

MILITARY SEALIFT COMMAND

Mr. Albert J. Attermeyer
Mr. Michael W. Touma
Mr. Jeffery E. Beach

MARITIME ADMINISTRATION

Mr. Frederick Seibold
Mr. Norman O. Hammer
Mr. Chao H. Lin
Dr. Walter M. Maclean

NAVAL SEA SYSTEMS COMMAND

Mr. Robert A. Sielski
Mr. Charles L. Null
Mr. W. Thomas Packard
Mr. Allen H. Engle

U. S. COAST GUARD

CAPT T. E. Thompson
CAPT Donald S. Jensen
CDR Mark E. Noll

SHIP STRUCTURE SUBCOMMITTEE LIAISON MEMBERS

U. S. COAST GUARD ACADEMY

LT Bruce Mustain

U. S. MERCHANT MARINE ACADEMY

Dr. C. B. Kim

U. S. NAVAL ACADEMY

Dr. Ramswar Bhattacharyya

STATE UNIVERSITY OF NEW YORK MARITIME COLLEGE

Dr. W. R. Porter

WELDING RESEARCH COUNCIL

Dr. Martin Prager

NATIONAL ACADEMY OF SCIENCES - MARINE BOARD

Mr. Alexander B. Stavovy

NATIONAL ACADEMY OF SCIENCES - COMMITTEE ON MARINE STRUCTURES

Mr. Stanley G. Stiansen

SOCIETY OF NAVAL ARCHITECTS AND MARINE ENGINEERS - HYDRODYNAMICS COMMITTEE

Dr. William Sandberg

AMERICAN IRON AND STEEL INSTITUTE

Mr. Alexander D. Wilson

Member Agencies:

United States Coast Guard
Naval Sea Systems Command
Maritime Administration
American Bureau of Shipping
Military Sealift Command



Ship Structure Committee

An Interagency Advisory Committee
Dedicated to the Improvement of Marine Structures

Address Correspondence to:

Secretary, Ship Structure Committee
U.S. Coast Guard (G-MTH)
2100 Second Street S.W.
Washington, D.C. 20593-0001
PH: (202) 267-0003
FAX: (202) 267-0025

November 8, 1990

SSC-337
SR-1290

SHIP FRACTURE MECHANISMS INVESTIGATION

Fracture mechanics and methods to control cracking in ship structures have been areas of fundamental research by the Ship Structure Committee since its inception in 1946. As this work continues, new technologies and theories concerning crack initiation and growth are evolving. It is only through continued research and careful observation of structural failures that we can gain further insight into controlling fractures in ship structures.

This report is divided into two volumes. Part 1 contains the details and conclusions of the investigation into ship fracture mechanisms. The investigation was based on existing research and case studies and on inspections of more recent hull girder fractures. Part 2 is a guide for investigators who are unfamiliar with fracture mechanics. It should prove to be a useful tool for evaluating and documenting ship fractures and in determining the cause of these failures.

J. A. SIPES
Rear Admiral, U.S. Coast Guard
Chairman, Ship Structure Committee



Accession For	
NTIS GRA&I	<input checked="" type="checkbox"/>
DTIC TAB	<input type="checkbox"/>
Unannounced	<input type="checkbox"/>
Justification	
By _____	
Distribution/	
Availability Codes	
Dist	Avail and/or Special
A-1	

1. Report No. SSC-337 (Part 2)		2. Government Accession No.		3. Recipient's Catalog No.	
4. Title and Subtitle Ship Fracture Mechanism - A Non-Expert's Guide for Inspecting and Determining the Causes of Significant Ship Fractures				5. Report Date 1987	
				4. Performing Organization Code SHIP STRUCTURES COMMITTEE	
7. Author(s) Karl A. Stambaugh, William A. Wood				8. Performing Organization Report No. SR-1290	
9. Performing Organization Name and Address Giannotti & Associates, Inc. 703 Giddings Avenue, Suite U-3 Annapolis, Maryland 21401				10. Work Unit No. (TRAIS)	
				11. Contract or Grant No. DTCG-83-C-20040	
12. Sponsoring Agency Name and Address U.S. Coast Guard Office of Merchant Marine Safety Washington, D.C. 20593				13. Type of Report and Period Covered Technical Report 5-15-83 - 9-15-86	
				14. Sponsoring Agency Code G-M	
15. Supplementary Notes The USCG acts as the contracting office for the ship structure committee.					
16. Abstract This document is the second part of a report on ship fracture mechanisms. It is a guide for inspectors and surveyors who are not experts in metallurgy or fracture mechanics and is intended to assist them in investigating and determining the causes of ship fractures. This report includes methods for carrying out an examination of fractures and guidance in documenting these failures. The full investigation of fracture mechanisms are found in Part 1 of this report.					
17. Key Words Fracture Fatigue Ship Structure			18. Distribution Statement This document is available for the U.S. public through the National Technical Information Service, Springfield, VA. 22161		
19. Security Classif. (of this report) Unclassified		20. Security Classif. (of this page) Unclassified		21. No. of Pages 54	22. Price

METRIC CONVERSION FACTORS

Approximate Conversions to Metric Measures		Approximate Conversions from Metric Measures						
Symbol	When You Know	Multiply by	To Find	Symbol	When You Know	Multiply by	To Find	Symbol
LENGTH								
in	inches	2.5	centimeters	cm	centimeters	0.04	inches	in
ft	feet	30	centimeters	cm	inches	0.4	inches	in
yd	yards	0.9	meters	m	feet	3.3	feet	ft
mi	miles	1.6	kilometers	km	meters	1.1	meters	m
					kilometers	0.6	miles	mi
AREA								
m ²	square meters	0.5	square centimeters	cm ²	square centimeters	0.16	square inches	in ²
ft ²	square feet	0.09	square meters	m ²	square meters	1.2	square yards	yd ²
yd ²	square yards	0.8	square meters	m ²	square kilometers	0.4	square miles	mi ²
ac	acres	2.5	hectares	ha	hectares (10,000 m ²)	2.5	acres	ac
MASS (weight)								
oz	ounces	28	grams	g	grams	0.035	ounces	oz
lb	pounds	0.45	kilograms	kg	kilograms	2.2	pounds	lb
	(1600 lb)	0.9	tonnes	t	tonnes (1000 kg)	1.1	short tons	sh
VOLUME								
l	liters	1	liters	l	milliliters	0.03	fluid ounces	fl oz
qt	quarts	0.95	liters	l	liters	1.06	pints	pt
gal	gallons	3.8	liters	l	liters	1.06	quarts	qt
cu ft	cubic feet	0.03	cubic meters	m ³	liters	0.26	gallons	gal
cu yd	cubic yards	0.76	cubic meters	m ³	cubic meters	36	cubic feet	ft ³
					cubic meters	1.3	cubic yards	yd ³
TEMPERATURE (exact)								
°F	Fahrenheit temperature	$\frac{5}{9}(\text{Fahr} - 32)$	Celsius temperature	°C	Celsius temperature	$\frac{9}{5}(\text{Cels} + 32)$	Fahrenheit temperature	°F

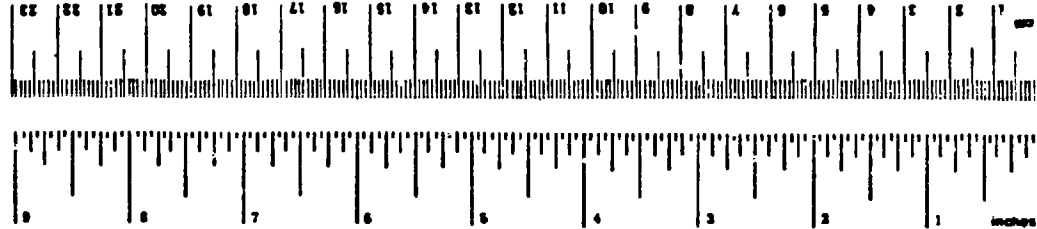

U.S. Metric Conversion Tables, NIST Special Publication 447-1, 1975. For other exact conversions and more detailed tables, see NIST Spec. Publ. 447-1, U.S. Metric Conversion Tables, NIST Special Publication 447-1, 1975. U.S. Metric Conversion Tables, NIST Special Publication 447-1, 1975.

TABLE OF CONTENTS

<u>Section</u>	<u>Title</u>	<u>Page</u>
1.0	INTRODUCTION.....	1-1
1.1	Purpose of this Guide.....	1-1
1.2	Significant Fractures - What They Are and Why They Are Serious.....	1-1
1.3	Value of Fracture Investigation.....	1-2
1.4	The Causes of Significant Fractures.....	1-2
2.0	EXAMINATION OF A SIGNIFICANT FRACTURE ON SITE.....	2-1
2.1	Preparations for the Inspection.....	2-1
2.2	Inspection and Documentation of the Fracture Path.....	2-1
2.3	Location of the Fracture Origin.....	2-3
2.4	Characterization of the Ship Structure.....	2-8
2.5	Determination of the Circumstances at the Time The Fracture Occurred.....	2-12
3.0	CAUSES OF SIGNIFICANT FRACTURES.....	3-1
3.1	Abnormal Forces.....	3-1
3.2	Presence of Flaws and Notches.....	3-1
3.3	Inadequate Physical Properties at Service Temperature.....	3-3
3.4	Combination of Causes.....	3-3
4.0	ILLUSTRATIVE EXAMPLE.....	4-1
4.1	Ship Characteristics.....	4-1
4.2	Circumstances at the Time of Fracture.....	4-1
4.3	Fracture Description From the On-Site Inspection.....	4-6
4.4	Location of the Fracture Origin.....	4-6
4.5	Cause of the Significant Fractures.....	4-11
5.0	GLOSSARY.....	5-1

LIST OF FIGURES

<u>Figure</u>	<u>Title</u>	<u>Page</u>
Figure 2-1	Illustration of Fracture Edges.....	2-2
Figure 2-2	Chevron Pattern of Significant Fractures.....	2-4
Figure 2-3	Dull, Gray Surface of a Ductile Fracture.....	2-5
Figure 2-4	Flat Surface on the Edge of a Fatigue Crack.....	2-6
Figure 2-5	Striations Caused by Fatigue Cracking.....	2-7
Figure 2-6	Example of Improper Butt Weld Showing Root Bead Under- cutting, Slag Inclusion, Lack of Fusion and Porosity.....	2-9
Figure 2-7	Arc Strike, Showing the Cracking Patterns That Can Result.....	2-10

TABLE OF CONTENTS, (continued)

LIST OF FIGURES

<u>Figure</u>	<u>Title</u>	<u>Page</u>
Figure 2-8	Illustration of the Notch Effect Caused by Fillet Weld.....	2-11
Figure 2-9	Illustration of the Notch Effect Produced by an Internal Corner.....	2-12
Figure 2-10	Locating the Origin of a Fracture by Chevron Points.....	2-13
Figure 2-11	Fracture Surface at the Origin of a Significant Fracture at a Weld Crack.....	2-14
Figure 3-1	Illustration of Bending Forces that Cause Significant Fractures.....	3-2
Figure 3-2	Fracture Energy vs. Temperature for Typical Shipbuilding Steels.....	3-4
Figure 4-1	Midship Section Indicating the Area of Fracture on the Great Lakes Bulk Carrier.....	4-2
Figure 4-2	Section of the Upper Wing Tank of the Great Lakes Bulk Carrier.....	4-3
Figure 4-3	Fracture Path on the Spar Deck of the Great Lakes Bulk Carrier.....	4-4
Figure 4-4	Fracture Path in the Longitudinal Bulkhead of the Great Lakes Bulk Carrier.....	4-5
Figure 4-5	Construction Details Associated with the Initiation of the Fracture on the Great Lakes Bulk Carrier.....	4-7
Figure 4-6	Location of Plating Samples from the Great Lakes Bulk Carrier.....	4-8
Figure 4-7	Location of the Fracture Origin in Sample No. 1.....	4-9
Figure 4-8	Location of the Fracture Origin in Sample No. 6.....	4-10
Figure 4-9	Fracture Propagation and Initiation Between Samples No. 6 and No. 7.....	4-12
Figure 4-10	Piece No. 3 (Top of Longitudinal Bulkhead) Initiation Site Showing Crack Entering Piece No. 3 through Weld of Angle to Piece No. 3. Crack Goes to Rivet Hole on Right and Down the Bulkhead.....	4-13

TABLE OF CONTENTS, (continued)

LIST OF FIGURES

<u>Figure</u>	<u>Title</u>	<u>Page</u>
Figure 4-11	Plan of Spar Deck. Fracture Initiation and Arrest Points.....	4-14

LIST OF TABLES

<u>Table</u>	<u>Title</u>	<u>Page</u>
Table 3-1	Impact Test, Charpy V-Notch, Temperatures for ABS Grade Hull Structural Steels.....	3-5

1.0 INTRODUCTION

1.1 PURPOSE OF THIS GUIDE

Have you ever been asked to examine a fracture in a ship's structure? Did you have any idea what you were looking for or what information you were going to give the person who asked you to look at the fracture? This Guide will help you if you are ever in this position again. Accordingly, this guide is written in non-technical terms without presupposing the examiner has an engineering degree. In particular, it will help you step through an "on-site" fracture examination and help you identify the facts needed to determine the cause of the fracture.

Once a fracture has occurred, you must determine and correct its cause to assure that the fracture will not recur. That is, in fact, why you examine the fracture, why you should take fractures seriously, and why we have written this Guide.

1.2 SIGNIFICANT FRACTURES - WHAT THEY ARE AND WHY THEY ARE SERIOUS

There are numerous types of ship fractures; however, they fall into two categories: nuisance cracks and significant fractures.

Nuisance cracks often occur in the ship structure. They propagate slowly and do not affect the overall strength of the ship. They are detected before they propagate into adjacent structural members and are usually repaired by welding.

Significant fractures are a more serious threat to a ship's structural integrity. Although significant fractures in ship structure have not received much publicity in recent years, they do occur.¹ Such fractures present problems to owners and operators of ships. For example, ships with significant fractures must be repaired, resulting in time out of service and higher overall operating costs. Also, their potential to cause catastrophic failure cannot be understated because significant fractures usually propagate in a direction perpendicular to the longitudinal, continuous structure of the ship and extend through plates, stiffeners and other important structural members. The fracture can actually degrade the strength and integrity of ship structure to such an extent that the ship is unseaworthy. This type of fracture can cause a loss of watertight integrity or complete failure of the ship structure.

¹The parent project for this guide presents a description of several recent significant fractures that have occurred in ship structures. The reference is: "Ship Fracture Mechanisms Investigations" by Giannotti & Associates for the Ship Structures Committee, 1986. See Part 1 of this report.

1.3 VALUE OF FRACTURE INVESTIGATION

A fracture investigation enables you to learn the facts that characterize the fracture and study them to determine the cause of the fracture. A fracture analyst is required to deduce the conditions and circumstances under which the fracture occurred from information available on site, where the fracture is visible for inspection and pertinent circumstances are known. By using the steps and examples presented in this Guide, it should be possible in many cases for a non-expert to assume the role of fracture analyst and to successfully determine the cause of the fracture.

1.4 THE CAUSES OF SIGNIFICANT FRACTURES

Three factors, acting separately or together, are responsible for the formation of significant ship fractures:

1. Abnormal forces in or on the ship structure;
2. Presence of flaws or notches in the structure where fractures originate;
3. Inadequate physical properties of the structural steel at service temperatures.

Remember these three factors during the examination and you will be able to key in on the important information. Additional explanation of these factors is presented later in the Guide. An illustrative example and glossary are also presented as information that will help you determine the cause of a fracture.

2.0 EXAMINATION OF A SIGNIFICANT FRACTURE ON SITE

The characteristics of the fracture, ship structure and circumstances at the time of fracture are obtained onboard the ship where the significant fracture occurred. Any subsequent analysis either qualitative or quantitative will be based on this information, so it is imperative that the information is the most accurate available. A note of caution: avoid forming a pre-conceived opinion early in the investigation. Only after you have gathered and examined all the facts and data from the on-site examination should you offer your opinion on the cause.

2.1 PREPARATIONS FOR THE INSPECTION

Ships are normally repaired quickly and then returned to service. Therefore, you must make appropriate arrangements to examine the fracture promptly, before it is repaired. Ship operators are sensitive to publicity about fractures in their ships and you should be aware of this when you make the arrangements to inspect the fracture.

The equipment needed to conduct the on-site examination, in an expedient manner, includes:

1. Flashlight - to inspect the inside of the ship where there is usually little light available for visual inspection;
2. Camera - to photograph the fracture surface and surrounding structure;
3. Note and sketch pad - to note relevant facts and structural details along the path of the fracture;
4. Tape measure - to measure dimensions of structure;
5. Magnifying glass - for close inspection of fracture surface characteristics.

When you conduct the investigation, be prepared to document the facts through photographs, sketches and written notes. This data and information will be used when the on-site examination is complete and the facts are evaluated.

2.2 INSPECTION AND DOCUMENTATION OF THE FRACTURE PATH

All fracture examinations start by inspecting the fracture and its path. Inspect the fracture visually, determine the mode of fracture and document the fracture's length and location.

A visual inspection of the fracture edge will allow you to verify that a significant fracture has occurred. Also, the fracture edge or face will have information on it that will indicate the mode of failure (see Figure 2-1 for example).

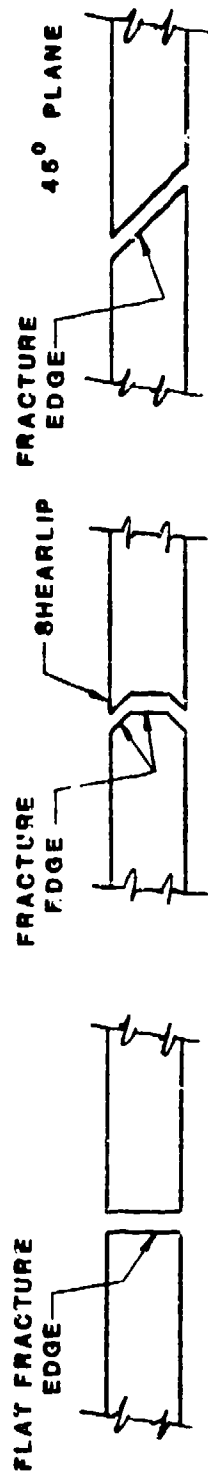
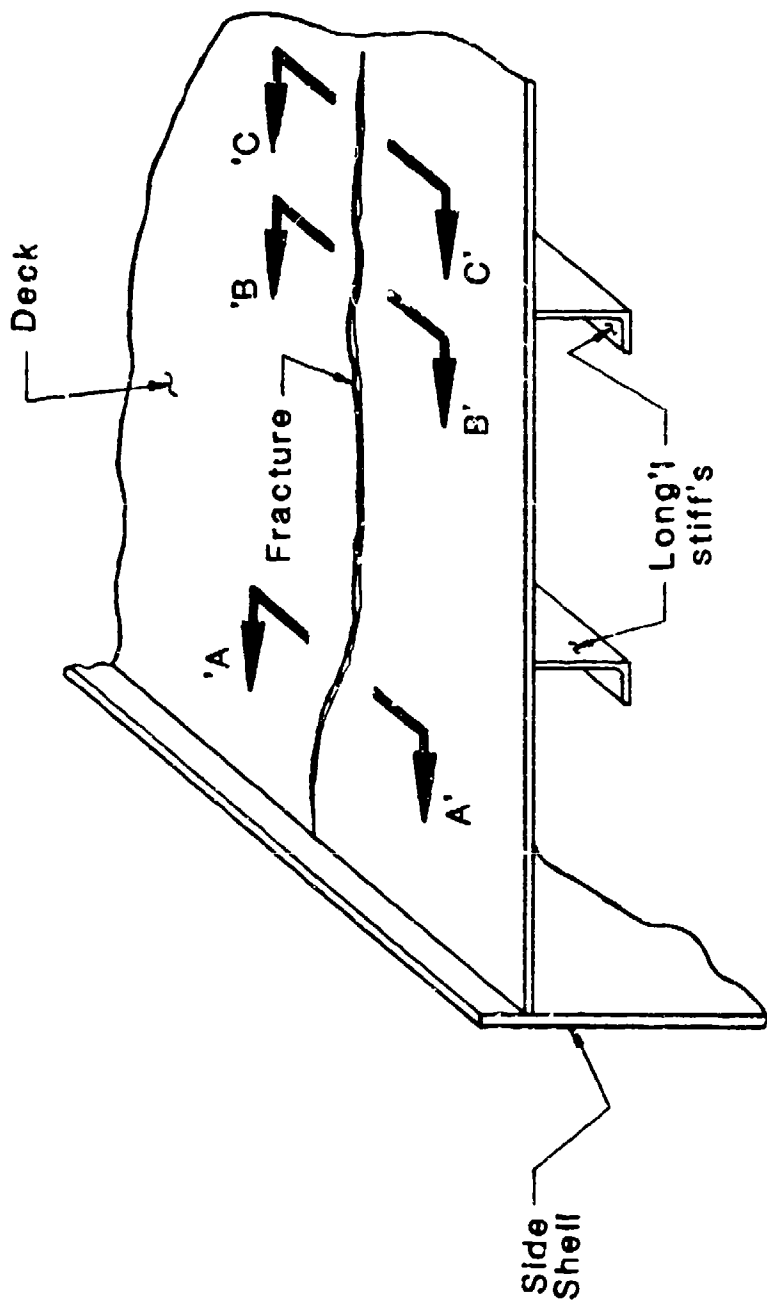

Section 'A-A'

Section 'B-B'

Section 'C-C'

Figure 2-1. Illustration of Fracture Edges

Significant fractures will have a relatively flat edge with characteristic chevron or herringbone pattern on the face of the fracture as shown in Figure 2-2. The typical significant fracture will appear bright and granular. Significant fractures occur very rapidly and in a brittle manner. They are often called brittle fractures. This type of fracture is the most serious because it propagates through the structure almost instantaneously. Welded ship structures are not forgiving of significant fractures because they provide a continuous path for the unstable, rapid propagation of the fracture.

There are other modes of fracture that contrast the features seen in a significant fracture. The other modes of fracture may be seen in conjunction with significant fractures. One other type of fracture mode is known as a ductile fracture and propagates at a much slower rate than a brittle fracture. The distinguishing feature on the edge of the ductile fracture is due to tearing where the steel is stretched slightly, and broken on 45° planes as shown in Section B'B' and C'-C' of Figure 2-1. The 45° surface planes often form a sharp edge and are called shear lips as shown in Section B'-B' of Figure 2-1. The face of the ductile fracture will appear dull gray and non-granular as shown in Figure 2-3. This less common mode of fracture is generally found at the ends of a brittle fracture. Fatigue cracking is another type of fracture mode and is usually found at the origin of significant fractures. You can identify a fatigue crack by looking at the fracture surface which is characteristically flat and smooth in appearance as shown in Figure 2-4. Small lines on the face of the fatigue crack can be more pronounced, as shown in Figure 2-5. The lines, if visible, are parallel, occur in groups in a direction perpendicular to the direction of crack propagation, and are usually bowed out in the direction of local propagation.

If the fracture is closed and the edge surface is not visible, fracture samples, which include the fracture edge, should be cut from the structure to permit examination of the fracture edge. The samples may be cut with a hole saw or flame cut depending on the availability of equipment and personnel. If samples are cut with a hole saw they should not be smaller than 2" in diameter to obtain the patterns on the face of the fracture. If samples are flame cut they should be wider than eight times the thickness of the plate so the material properties on the fracture face are not changed. Samples should be cut from each end of the fracture, at structural details between the ends of the crack and at the midpoint in the fracture path. Carefully number and locate the fracture samples on sketches or in photographs. Preserve the fracture surface by coating it with a very thin clear laquer to inhibit formation of rust that could obscure distinguishing features on the fracture edge.

The fracture path should be located and documented in sketches or photographs for future reference. The location of the fracture should be referenced to adjacent structure (longitudinal bulkheads, transverse bulkheads, web frames, stiffeners) and the centerline, baseline, midship or perpendiculars.

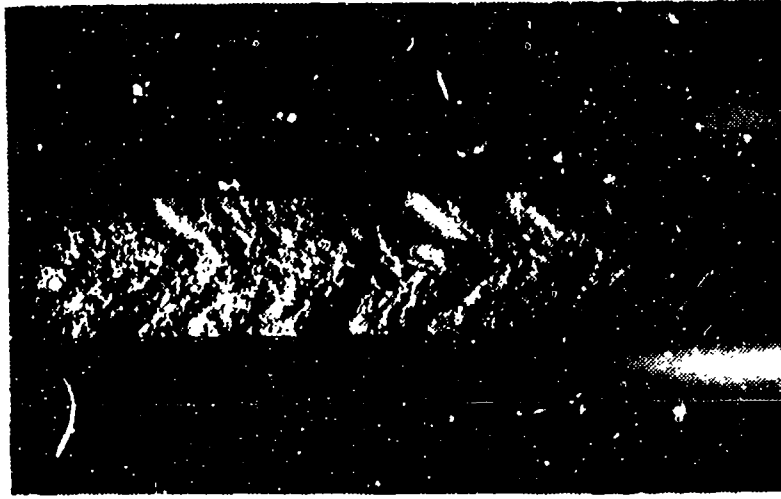

Figure 2-2. Chevron Pattern of Significant Fractures



Figure 2-3. Dull, Gray Surface of a Ductile Fracture



Figure 2-4. Flat Surface on the Edge of a Fatigue Crack

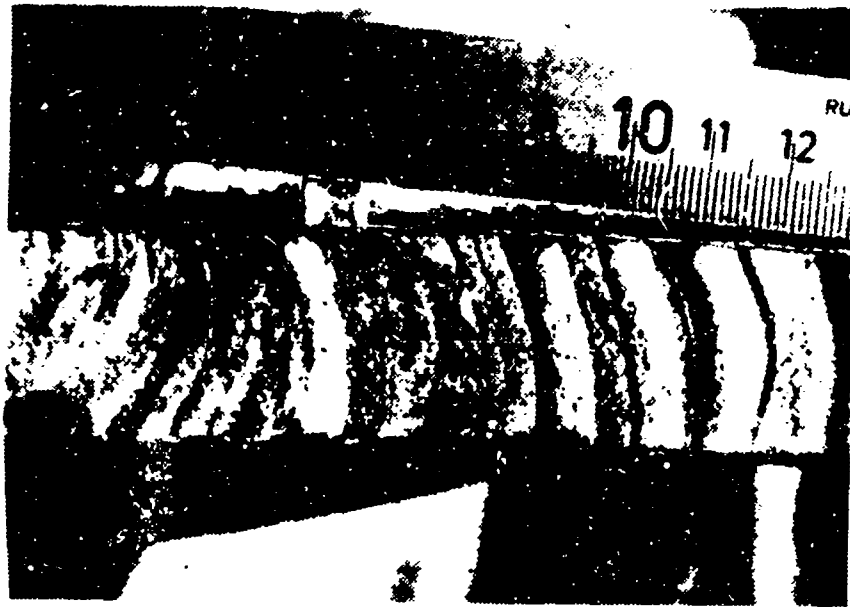

Figure 2-5. Striations Caused by Fatigue Cracking

2.3 LOCATION OF THE FRACTURE ORIGIN

The fracture origin is the location where the fracture started--its source. Locating the fracture origin is the most important part of the fracture investigation.

Before describing the procedure used to locate a fracture origin, several points concerning the origins themselves will be discussed. Fracture origins fall into two basic categories, namely flaws and notches, and both are associated with structural details or fabrication details.

A flaw is a small defect or imperfection in the material. Flaws can be located in the base metal, the weld or the heat-affected zone. Flaws range in size from microscopic to those visible to the unaided eye. There are many types of flaws; however, most are associated with the welds or heat affected zone. Examples of flaws in welds include lack of fusion, porosity, slag inclusions, and stray arc strikes. These flaws are depicted in Figures 2-6 and 2-7.

A notch is a structural discontinuity that creates locally high internal forces in the structure. Notches are usually associated with structural details or fabrication details. A structural detail is the geometry associated with structure intersections and fabrication details associated with weld geometry. A notch is produced by undercutting at a weld edge as shown in Figure 2-6, by placement of two welds too close together as shown in Figure 2-8, or by sharp internal corners as shown in Figure 2-9.

You will be able to locate the origin of a fracture by following the points of the distinctive chevron marks to the origin. The apex of the chevron marks points to the location where the fracture originated. Figure 2-10 illustrates this important feature of significant fractures. Note that the fracture origin is not necessarily at the ends of a fracture, but may be in the center of the fracture. In this case the fracture propagates in two directions, away from the origin. Often the chevron marks will appear near the origin and in other instances they will be less distinguishable at the origin; however, lines will radiate from the fracture origin as shown in Figure 2-11.

Significant fractures can and do originate at fatigue cracks; however, the fatigue cracks usually originate at flaws and notches as described above. Fatigue cracks then become large flaws.

After you locate and identify the origin, photograph it and sketch or photograph the structural and fabrication details in the immediate vicinity.

2.4 CHARACTERIZATION OF THE SHIP STRUCTURE

To characterize the ship and its structure you must document the particulars of the ship, the ship's structural configuration, and the structural details adjacent to the fracture.

The pertinent ship particulars include the ship type, basic dimensions (e.g., length, beam, depth, drafts), service speed, dead weight and operating routes. This information is useful for general documentation purposes and may be of interest if any of the characteristics are abnormal (e.g., a high ship speed can indicate higher than average forces on the structure).

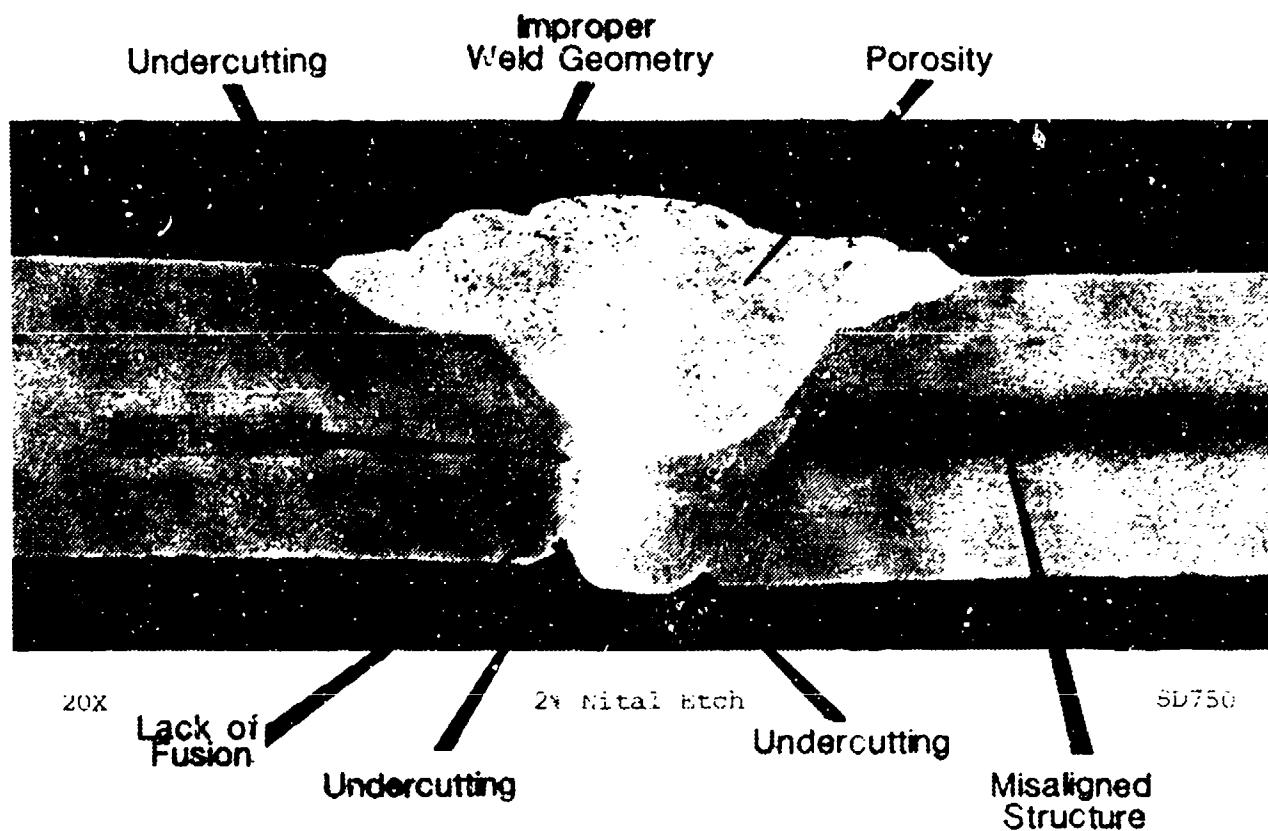

Figure 2-6. Example of Improper Butt Weld Showing Root Bead Undercutting, Slag Inclusions, Lack of Fusion and Porosity

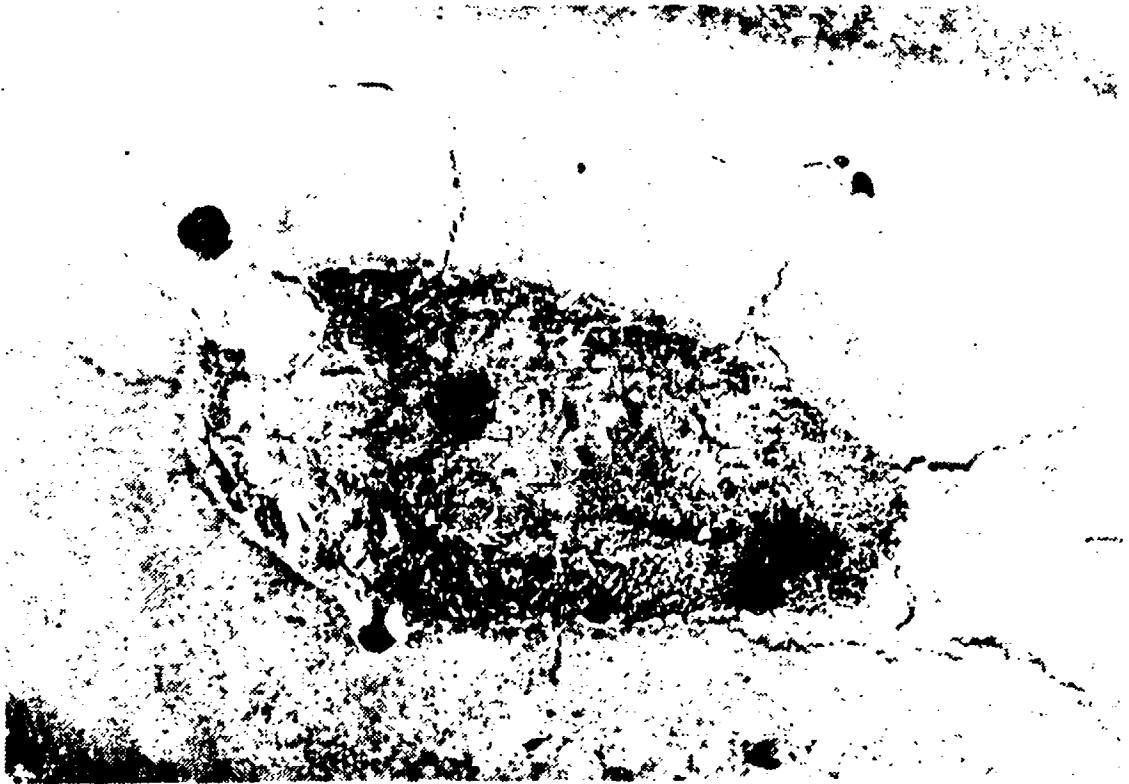

Figure 2-7. Arc Strike, Showing the Cracking Patterns that can Result

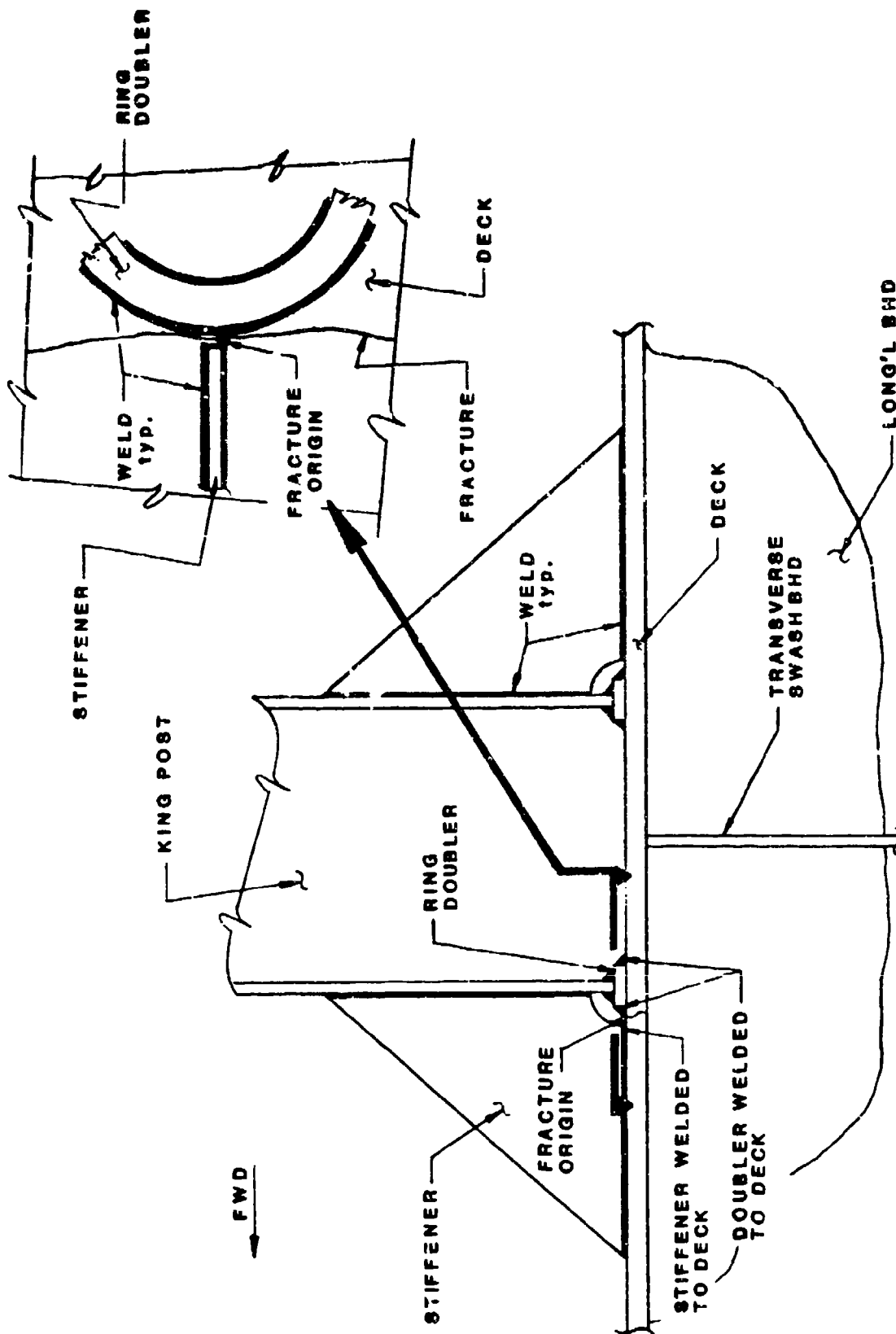
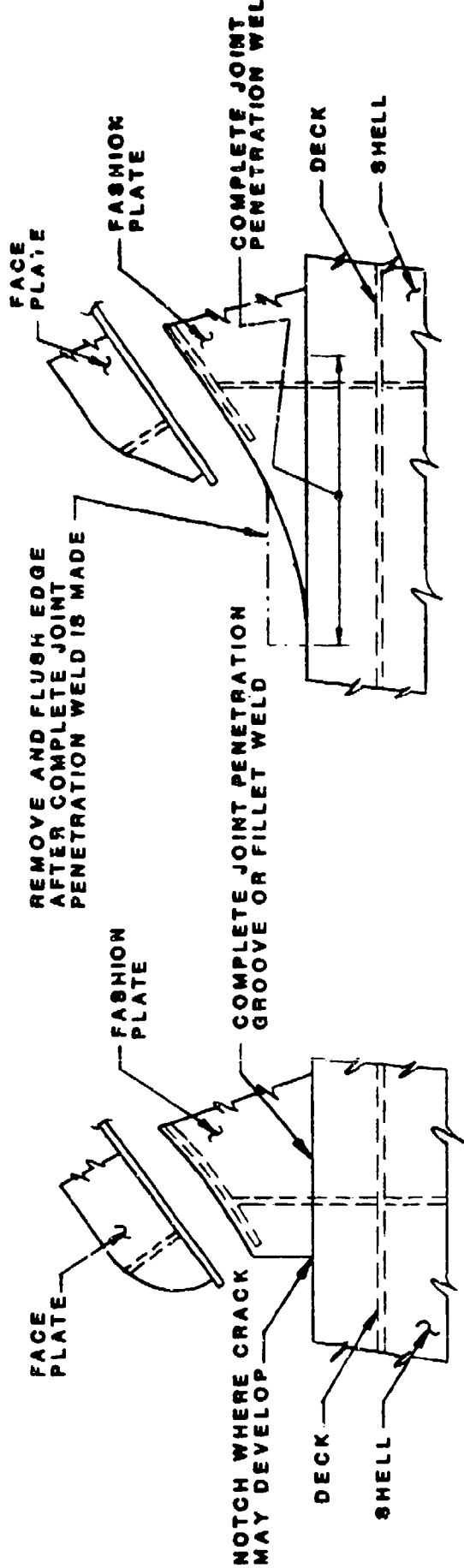

Figure 2-8. Illustration of the Notch Effect Caused by Fillet Weld



Poor Design

Improved Design

ENDING OF BULWARK FASHION PLATE WELDED TO TOP OF SHEERSTRAKE

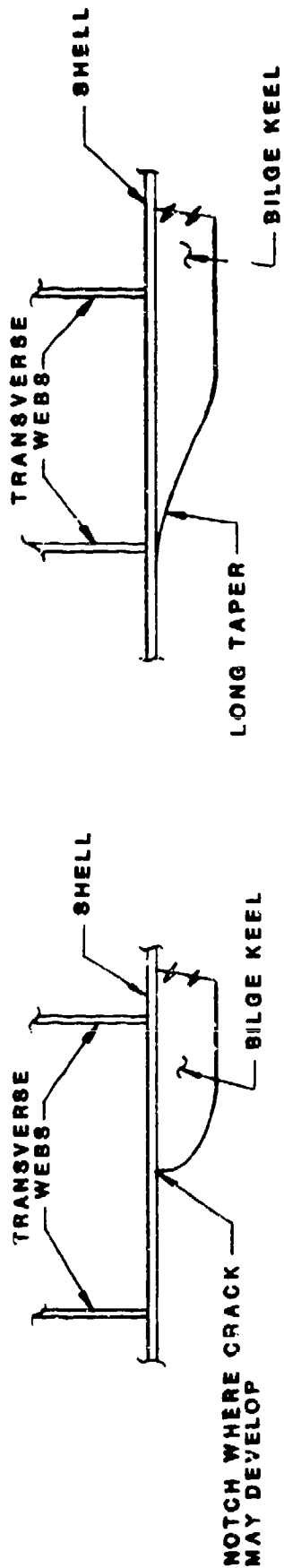

Poor Design

Good Design

BILGE KEEL ENDINGS

Figure 2-9. Illustration of the Notch Effect Produced by an Internal Corner

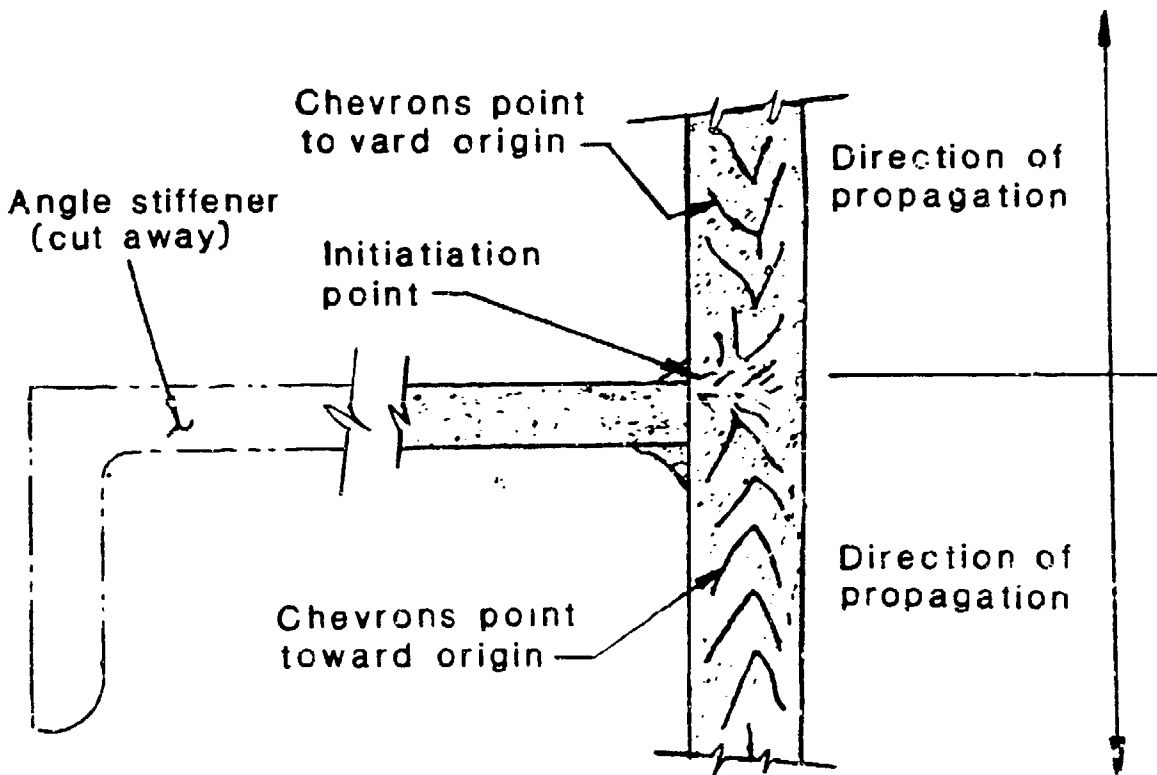
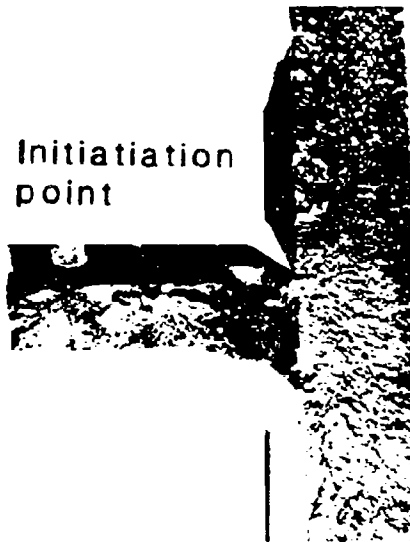

Figure 2-10. Locating the Origin of a Fracture by Chevron Points.

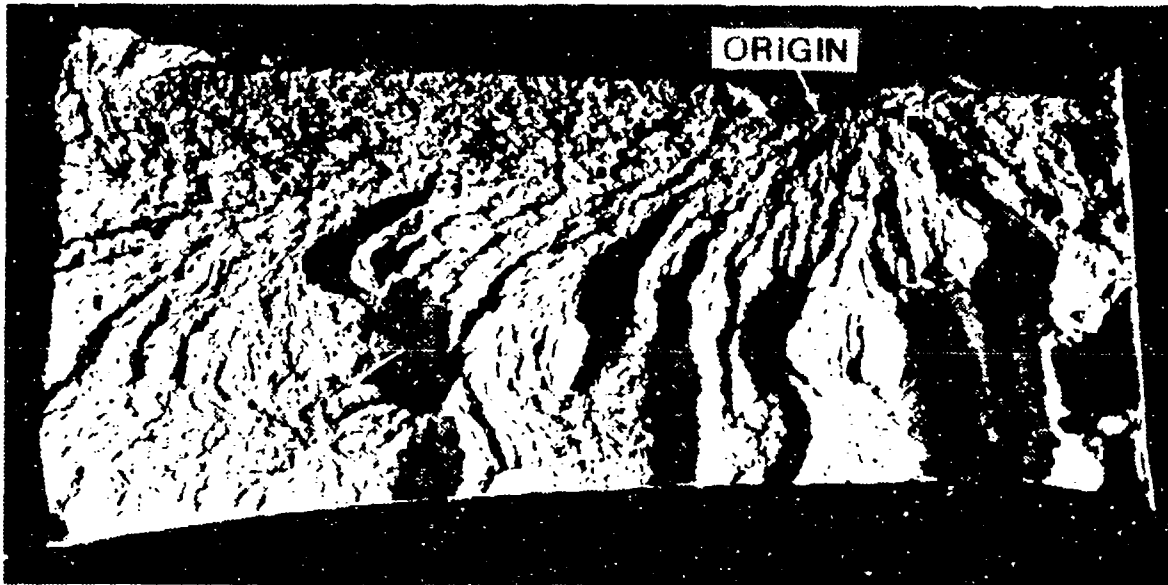

Figure 2-11. Fracture Surface at the Origin of a Significant Fracture at a Weld Crack

The ship's structural configuration should be documented by obtaining structural drawings of the ship if possible. A midship section will be of value because it shows the structure that is longitudinally continuous and the structural steel grades (e.g., ABS-A, B, D, AH, DH, EH, CS) throughout the path of the fracture. Note the actual as-built thicknesses for future reference; they may be different than the dimensions shown in the ship's drawings. Every structural intersection, cut-out and weld in the path of the fracture should be carefully examined and documented for future reference.

2.5 DETERMINATION OF THE CIRCUMSTANCES AT THE TIME THE FRACTURE OCCURRED

To complete the last step of the investigation you must identify and document the external factors that caused or contributed to the fracture initiation. The ship owner's representative or a member of the crew should have knowledge of the ship's operation at the time of fracture. All operating information should be obtained during the inspection. When you analyze the fracture you will find these factors are important:

1. Ship speed and heading;
2. Ship heading relative to prevailing sea conditions;
3. Wind speed and direction;
4. Beaufort number or wave height and length;
5. Sea and air temperatures;
6. Distribution and weight of cargo, ballast and other variable loads;
7. Displacement and drafts forward and aft;
8. Unusual circumstances (e.g., freak waves, bottom slamming, green water on deck).

The ship owner's representative or a crew member may know of any past history that may be of interest (e.g., past repairs and grounding). The ship's log book will have valuable information about ship operation, environmental conditions, and circumstances at the time of fracture.

3.0 CAUSES OF SIGNIFICANT FRACTURES

During the fracture examination you document important details about the fracture and the ship. Some of these details will be used for general informational purposes alone, while others, which are related to the causes of the fracture, will be reviewed in detail.

Remember, there are three factors that cause significant fractures. They are:

1. Abnormal forces in or on the ship's structure;
2. Flaws or notches in the structure where fractures originate;
3. Inadequate physical properties of the structural steel at service temperatures.

Each of these factors will be discussed in detail in the following sections.

3.1 ABNORMAL FORCES

A ship's structure encounters numerous forces during its lifetime. These forces result from operation in an adverse environment and the distribution of cargo, ballast and other loads within the ship. When these forces are abnormally high they can lead to significant fractures by increasing stress at flaws and notches to a point where the steel is unable to resist fracture propagation.

Severe storms cause unusually high forces on the ship's hull. Storm forces include wave impacts, bottom slamming, and green water on deck. These forces tend to bend and twist the ship's hull as shown in simplified form in Figure 3-1. As the ship drives through heavy seas, it pitches and rolls and its hull girder experiences terrific forces and moments from the waves. At the same time local forces are produced by the hull girder forces. When the weight is not distributed uniformly it causes excessive forces on the ship's hull that tend to bend the ship. This bending action produces forces in the ship's structure.

Improper distribution of weights has been responsible for significant fractures in the past even in calm water.

Improper structural design can cause or contribute to the presence of abnormal forces in structural members. Adequate strength, structural continuity and alignment are essential to minimize the local effects of abnormal forces encountered during the ship's life.

3.2 PRESENCE OF FLAWS AND NOTCHES

Flaws and notches are always present to some degree in ship structures. Examples are given in Section 2.4. Flaws are created during the manufacturing or fabrication procedure. Notches are created during the design and fabrication. If a flaw or notch is located at the origin of a fracture and no abnormal forces were encountered, then it can be considered that the flaw or notch



Vessel supported on a wave whose crests are at bow and stern. The vessel is supported at the ends and is said to be in the "sagging condition".



Vessel supported on a wave whose crest is midships. The vessel now is primarily supported amidships and is said to be in the "hogging condition".

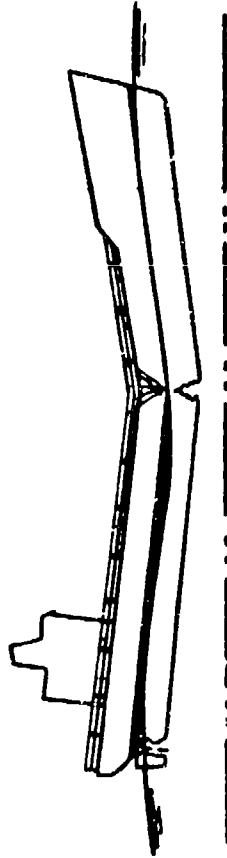

Type of hull girder failure that results from excessive stresses in the sagging condition.

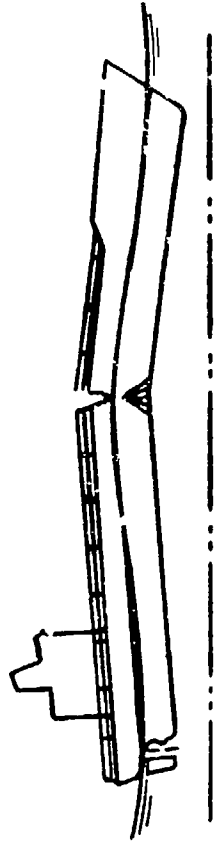

Type of hull girder failure that results from excessive stresses in the hogging condition.

Figure 3-1. Illustration of Bending Forces that Cause Significant Fractures

was the primary cause of the fracture. If, however, abnormal forces were encountered by the ship at the time of fracture then the flaws and notches merely formed a weak link and should be considered a contributing factor.

Fatigue cracking is caused by repeated or alternating forces acting on a structural flaw or notch. The fatigue cracks then become very large flaws which in turn become large enough to cause significant fractures. Fatigue cracks can range in size from microscopic to several inches in length before they eventually lead to a significant fracture. Corrosion usually contributes to fatigue cracking by local reduction in material thickness and acceleration of crack growth.

3.3 INADEQUATE PHYSICAL PROPERTIES AT SERVICE TEMPERATURE

The materials used in modern ship structures can withstand "normal" external forces at normal temperatures. However, at abnormally low temperatures, a material's properties change and this change can be the cause of a significant fracture. Table 3-1 gives lowest normal temperatures for various ABS steel grades. Use of the steels below their normal temperatures will result in reduced fracture resistance in the presence of a flaw or notch.

The reason temperature plays such an important role in the fracture behavior of ship's structure is that low temperatures tend to reduce the ability of the steel to resist crack growth. This relationship is shown graphically in Figure 3-2 for typical shipbuilding steels. At low temperatures it takes very little energy to cause a small crack to grow and once it begins to grow, it will propagate very rapidly. This type of fracture is known as brittle fracture. At elevated temperatures relatively high energy is required to cause a small crack to grow and become a significant fracture. At normal temperatures cracks grow in a stable manner before they reach a critical size and propagate as a brittle fracture.

3.4 COMBINATION OF CAUSES

If no cause can be singled out as the cause of the significant fracture then you must conclude that the fracture was the result of a combination of factors or that further engineering analysis is necessary to distinguish between contributing factors. If you have followed each step described above you will be able to provide the fracture experts with the information they need to conduct a thorough engineering analysis.

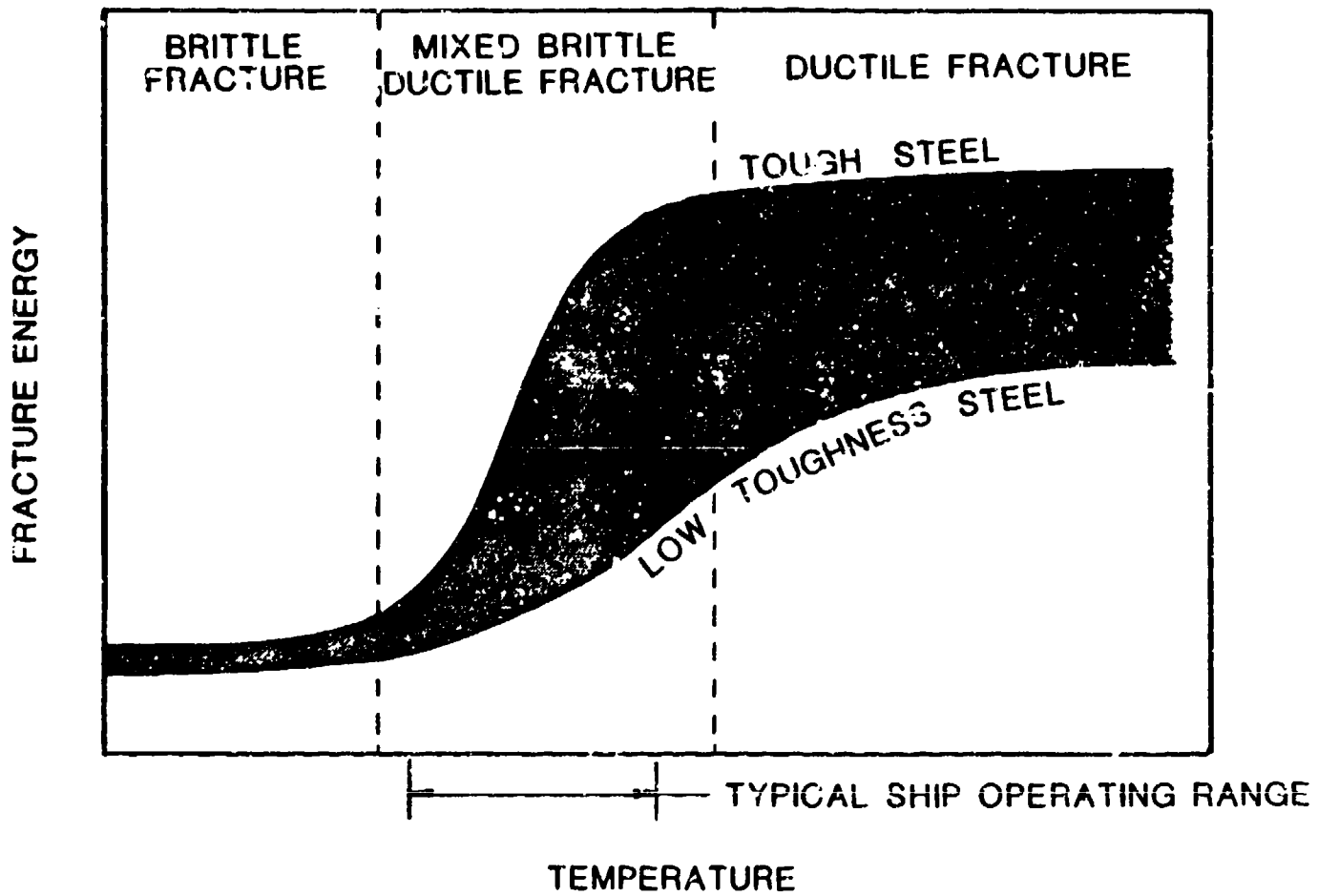

Figure 3-2. Fracture Energy vs. Temperature for Typical Shipbuilding Steels

TABLE 3-1
IMPACT TEST, CHARPY V-NOTCH,
TEMPERATURES FOR
ABS GRADE HULL STRUCTURAL STEELS*

<u>Grades</u>	<u>Test Temperature</u>
A	**
B	32°F (0°C)
D	14°F (-10°C)
E	-40°F (-40°C)
DS	**
CS	**
AH32	32°F (0°C)
DH32	-4°F (-20°C)
EH32	-40°F (-40°C)
AH36	32°F (0°C)
DH36	-4°F (-20°C)
EH36	-40°F (-40°C)

*For complete requirements, consult ABS Rule for Building and Classing Steel Vessels.

**No test temperature requirements for these steel grades. The mill requirements for DS and CS grade produce steels that are tougher than the E and EH steels.

4.0 ILLUSTRATIVE EXAMPLE

A fracture that occurred in a Great Lakes bulk carrier will serve as an example¹ to illustrate the steps of the fracture investigation.

4.1 SHIP CHARACTERISTICS

The ship was a Great Lakes bulk carrier that was built in 1952 and lengthened 70 feet in 1957. In 1959 a sheer strap was added and the ship was converted to a self-unloader in 1980. The particulars of the ship at the time of fracture were:

Length overall:	698 ft
Length between perpendiculars:	683 ft
Breadth (molded):	70 ft
Depth:	37 ft
Displacement:	30054 L.T.
Year built (lengthened):	1952 (1957).

Figures 4-1 through 4-4 show the structural configuration of the ship while configured as a bulk carrier. The ship is transversely framed on the bottom and up the sides to the lower boundary of the upper wing tank. Above this elevation the ship is longitudinally framed. The calculated section moduli for the ship, in its various configurations, are as follows:

Ship status	Minimum Section Modulus in ² -ft
Original	34,800
Lengthened	34,800
Sheer strap addition	35,853
Self unloader	35,962.

The sheer straps were added in 1959 because the ship was thought to be too flexible because it exhibited large hull girder deflections during loading. After adding the sheer straps, an additional 6" of load line draft was permitted by the classification society because of the increased section modulus.

4.2 CIRCUMSTANCES AT THE TIME OF FRACTURE:

The fracture occurred on the bulk carrier on its last voyage prior to layup for the 1984 winter season. The ship was sailing Lake Huron when the crew heard a loud noise. An inspection by the crew revealed a fracture in the main deck on the starboard side near amidships.

The available information pertaining to the ship and fracture incident includes:

¹Several other examples are presented in the parent project referenced at the beginning of the Guide.

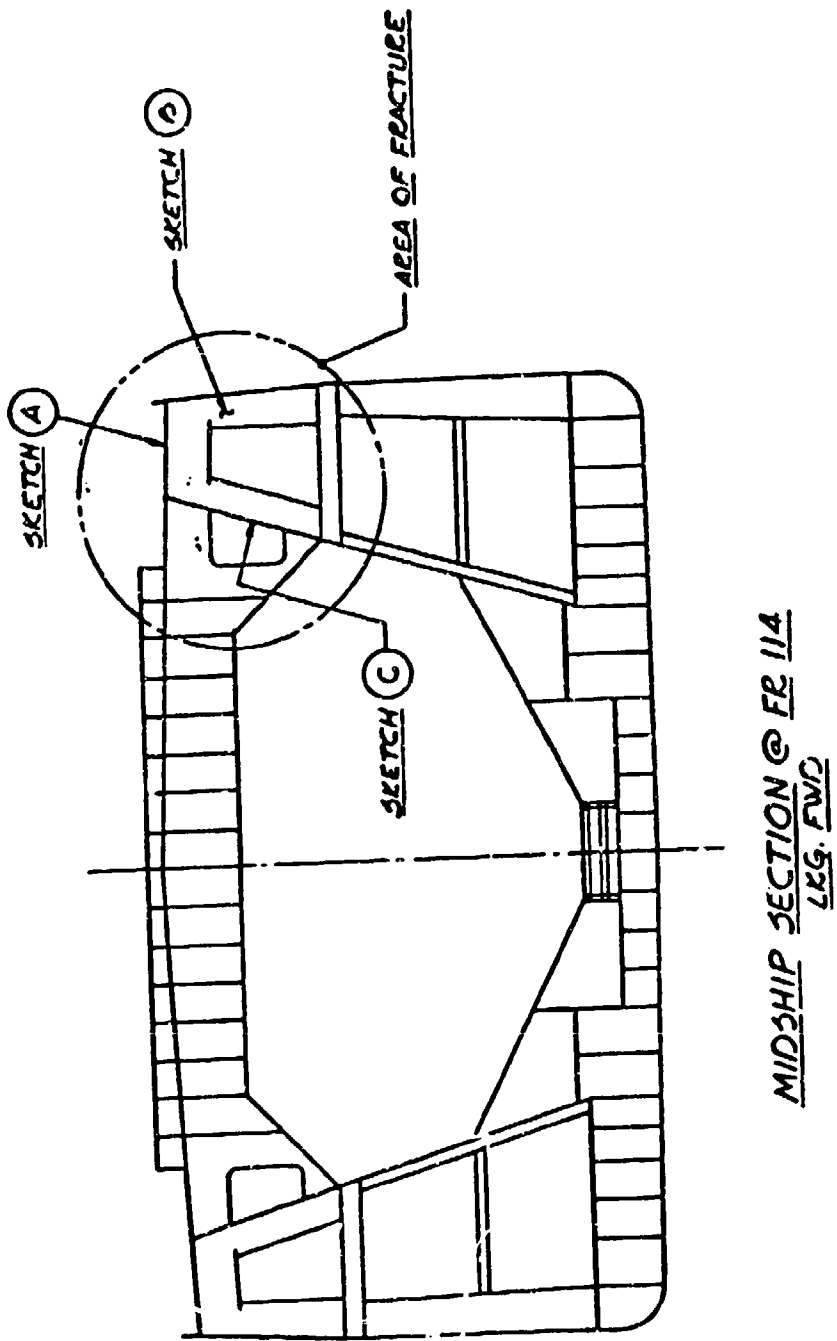
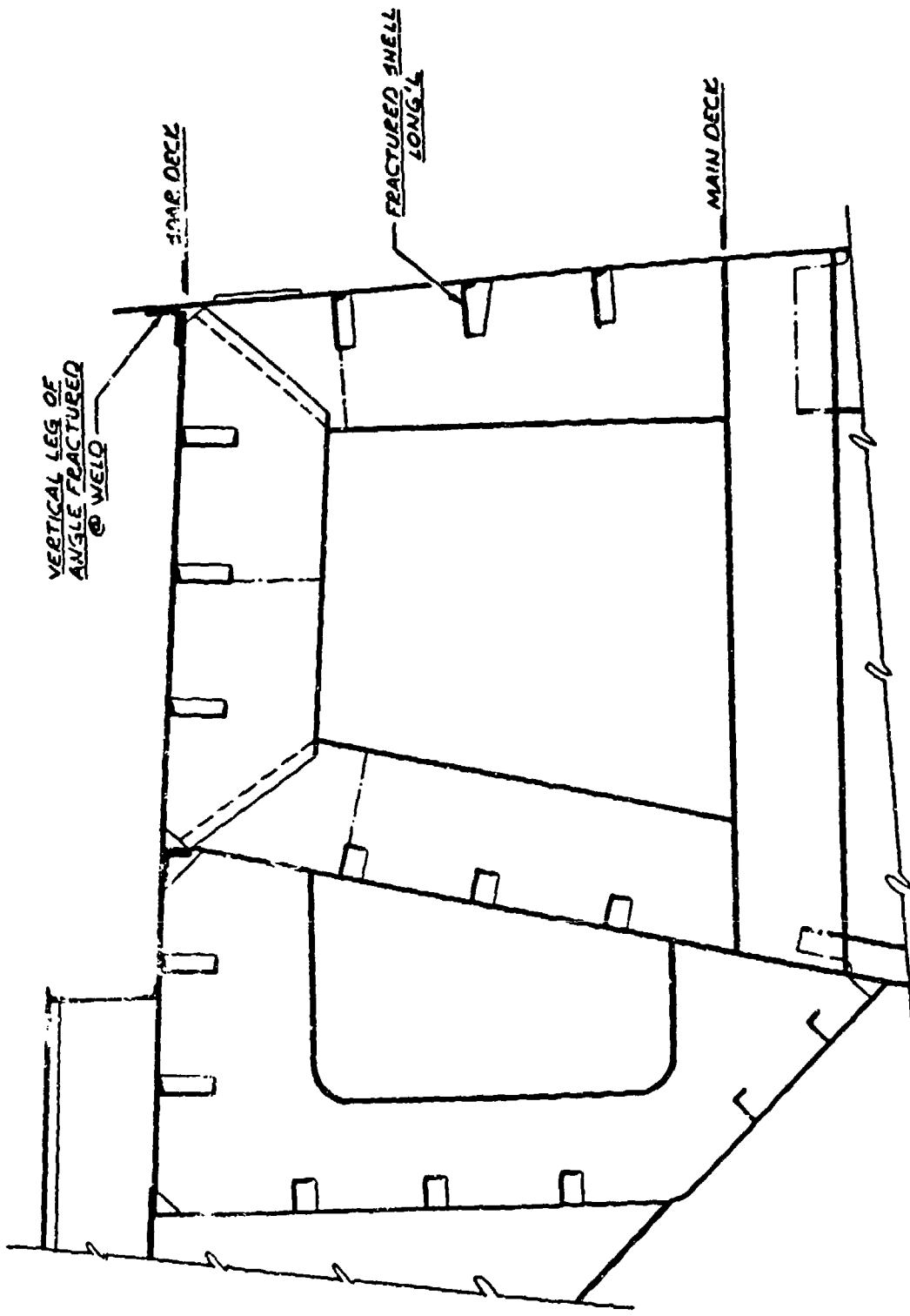
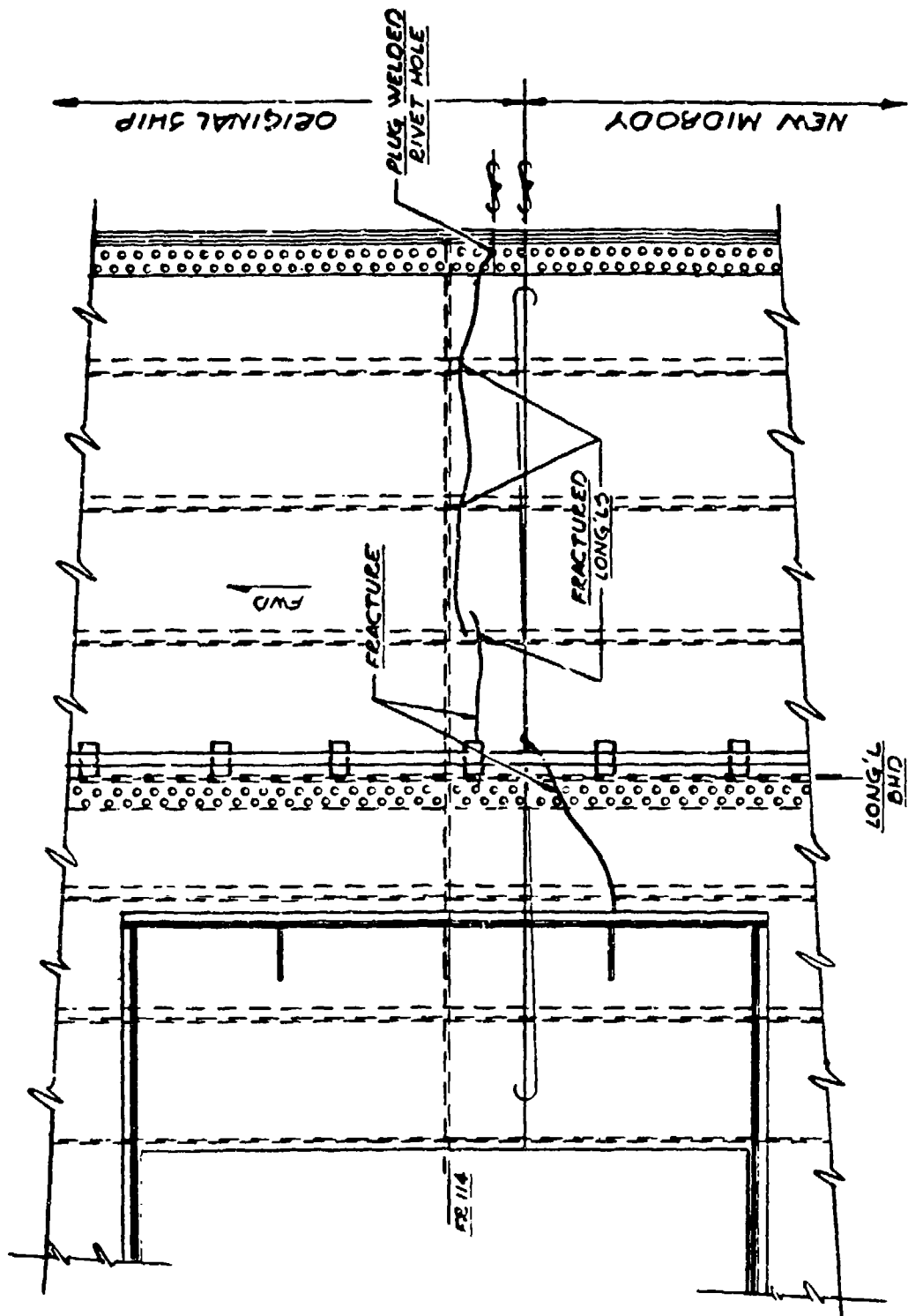

Figure 4-1. Midship Section Indicating the Area of Fracture on the Great Lakes Bulk Carrier



SKETCH BY
WEB FEB 1964

Figure 4-2. Section of the Upper Wing Tank of the Great Lakes Bulk Carrier



SKETCH A
PLAN OF SPAR DECK @ FR 114

Figure 4-3. Fracture Path on the Spar Deck of the Great Lakes Bulk Carrier

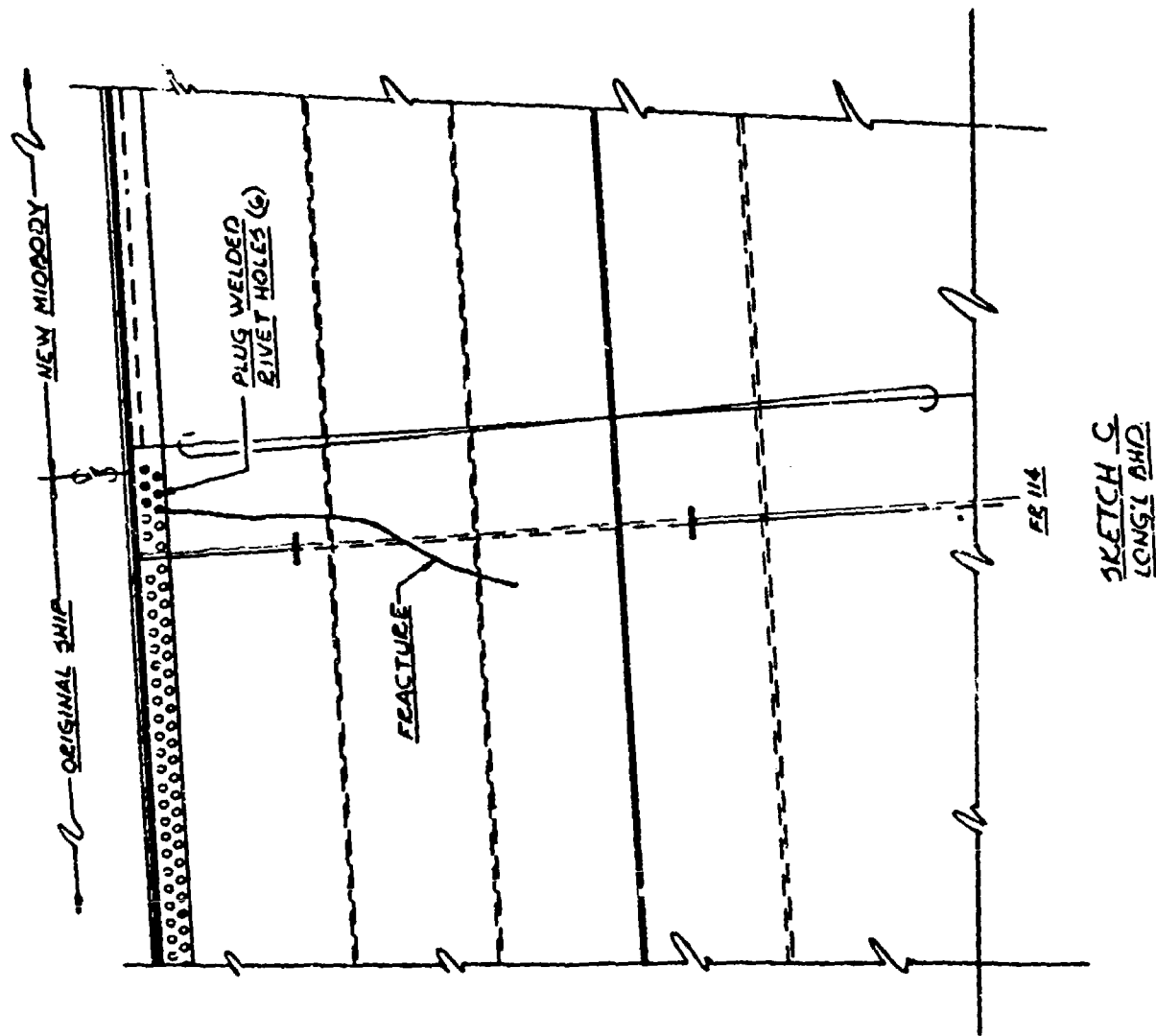

Figure 4-4. Fracture Path in the Longitudinal Bulkhead of the Great Lakes Bulk Carrier

- Date of fracture: 21 Dec. 1983
- Location of ship during fracture incident: Lake Huron
- Voyage number: 56
- Observed wave height: 12'-15'
- Wind speed and direction: 45 knots, 125° true
- Ship heading: 157° true
- Air temperature: 20°F.

The ship was reportedly in a normal ballast condition at the time of fracture.

4.3 FRACTURE DESCRIPTION FROM THE ON-SITE INSPECTION

The fracture was examined on site. There were three separate fractures crossing the starboard side of the spar deck where the ship had been joined during the lengthening process. Two of the fractures occurred in the original ship and one in the new midbody section (Figure 4-3). Upon examination below the spar (main) deck the reason for the separate fractures became apparent. A number of poor fabrication details were used in lengthening the vessel. These included plug welded rivet holes, mismatched structural members, weld used as filler for mismatched areas and notched longitudinals. The longitudinals under the spar deck consisted of channels with the flange welded to the underside of the deck at the toe and heel. The flange was welded to the underside of the deck and was cut out in way of butt welds on the longitudinals as shown in Figure 4-5. The three outboard longitudinals all fractured at this location. The fracture path in the spar deck plate ran through the notches created at the longitudinal butt welds and ran into the longitudinal bulkhead (Figure 4-4). The fracture surface visible in the longitudinal bulkhead during the on-site examination exhibited the classic chevron markings indicative of a brittle fracture. However, the exact location of the fracture origin could not be determined on site because the edge of the entire fracture could not be inspected visually. Samples were cut out of the fractured plating for further examination of the fracture path. The locations of these samples in the spar deck and longitudinal bulkhead are shown in Figure 4-6.

4.4 LOCATION OF THE FRACTURE ORIGIN

The origins of the various fractures were located by inspecting the edge of the fracture samples and establishing the orientation of chevron patterns. All the samples taken had clearly developed chevron marks. Examples of these markings on the surface of piece No. 1, which were typical, are seen in Figure 4-7. Sample No. 1 was cut from the spar deck plating located at the edge of the hatch coaming and extending outboard along part of the fracture surface as shown in Figure 4-6. Clear chevron markers point to the initiation site located in the transverse weld joining the coped out longitudinal flanges to the deck plate as shown in Figure 4-5. The fracture ran in two directions: under the hatch coaming and outboard across the deck through sample No. 9 and on into sample No. 2 where it terminated. As far as sample No. 9 is concerned, the fracture simply extended through this plate and did not directly result in propagation of fractures into the longitudinal bulkhead.

Sample No. 6 contains two separate fractures. Cutting the sample to reveal the fracture surfaces showed that the aft-most fracture extended inboard and outboard. From Figure 4-8 it can be seen that the chevrons point toward the

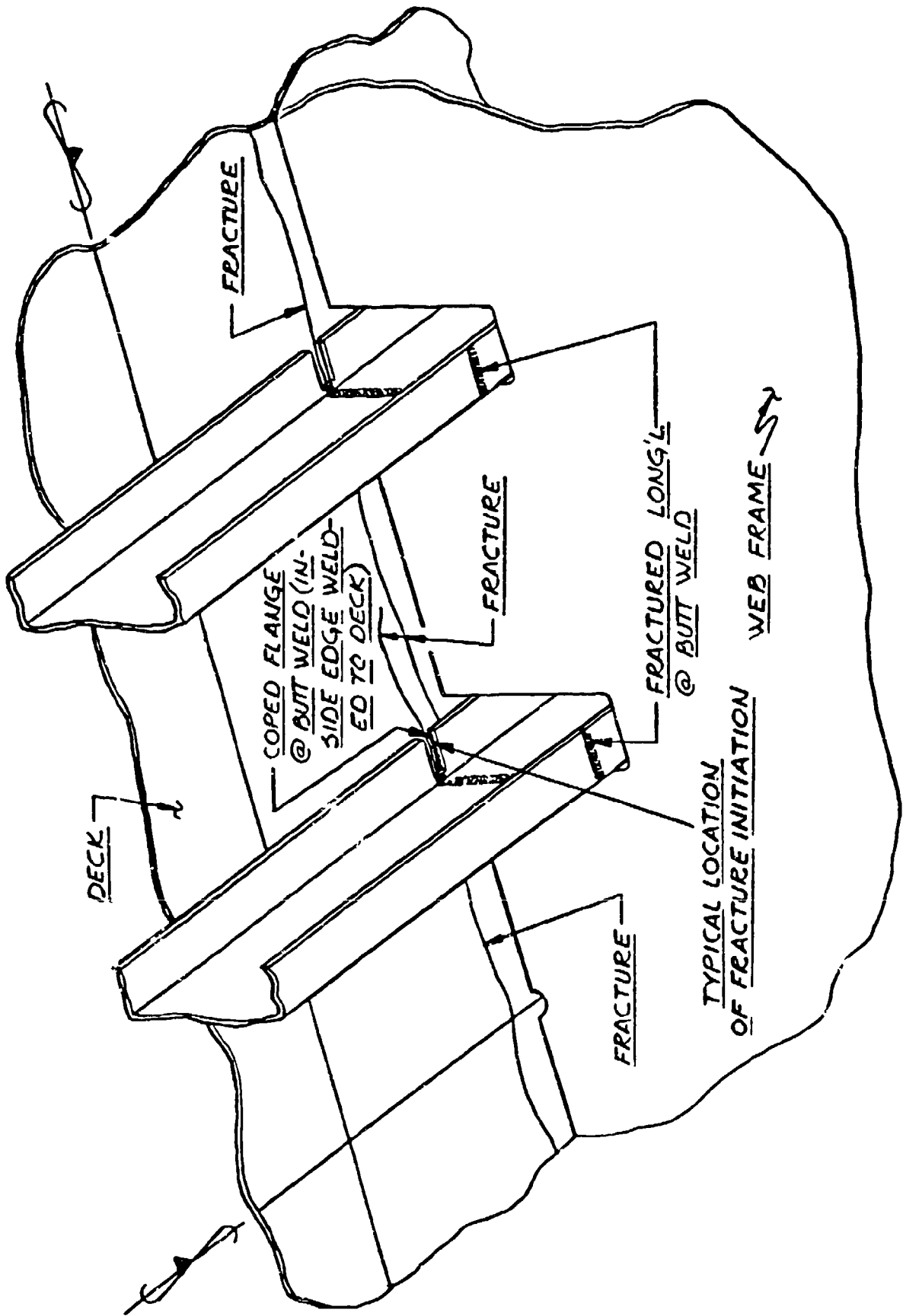
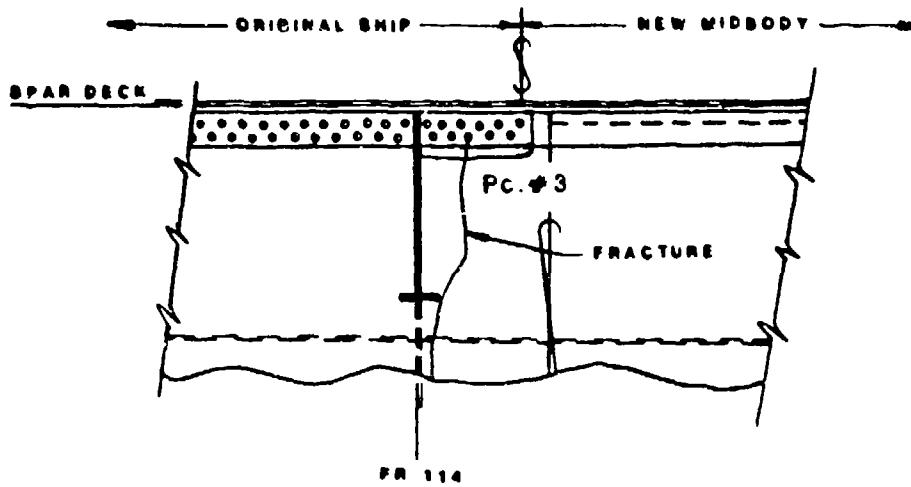
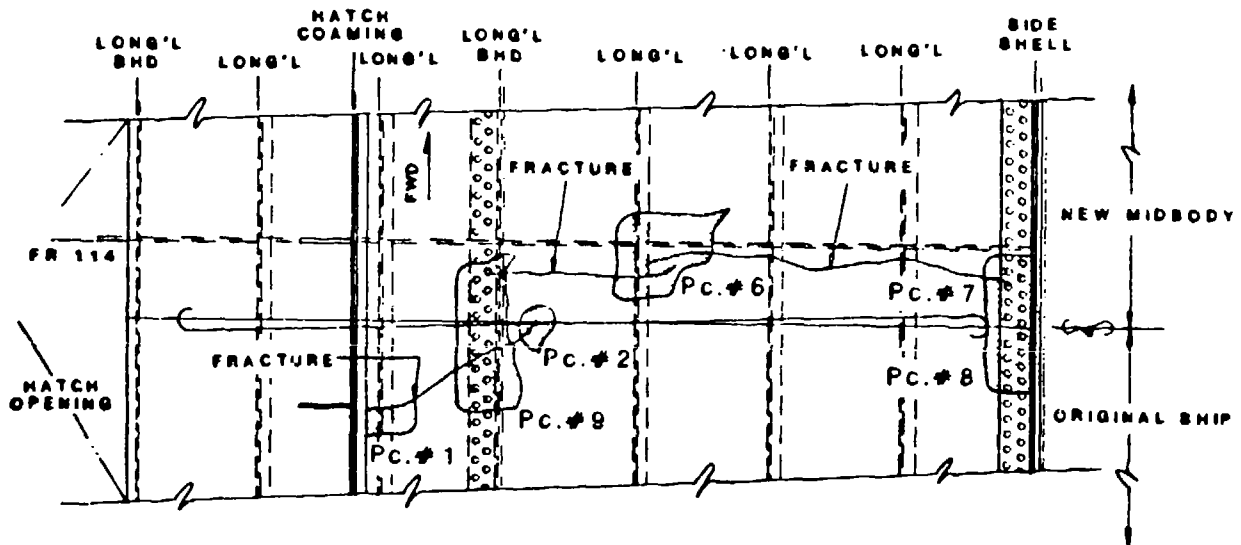

Figure 4-5. Construction Details Associated with the Initiation of the Fracture on the Great Lakes Bulk Carrier



ELEVATION OF LONG'L BHD



PLAN OF SPAR DECK

Figure 4-6. Location of Plating Samples from the Great Lakes Bulk Carrier.

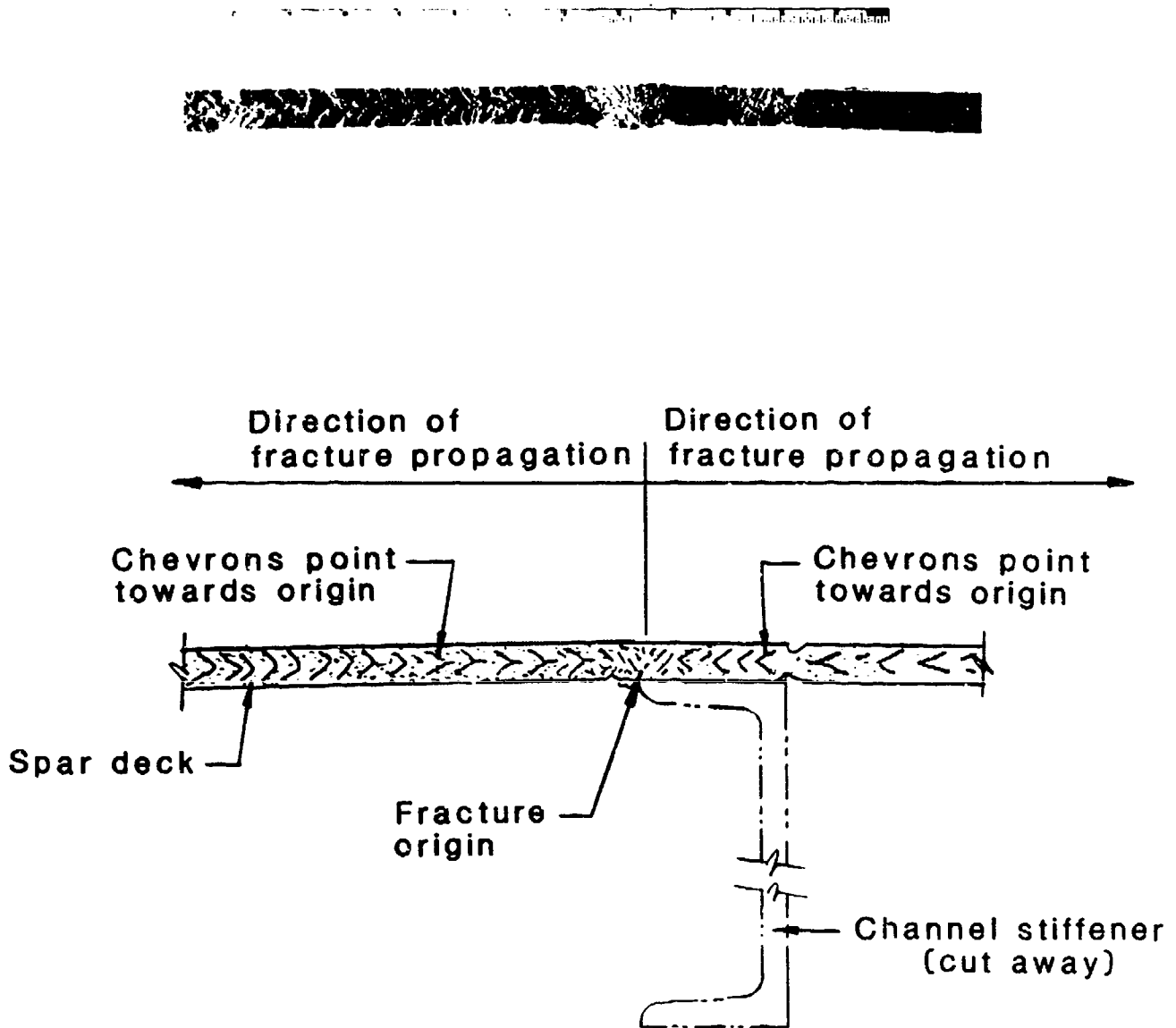

Figure 4-7. Location of the Fracture Origin in Sample Number 1.

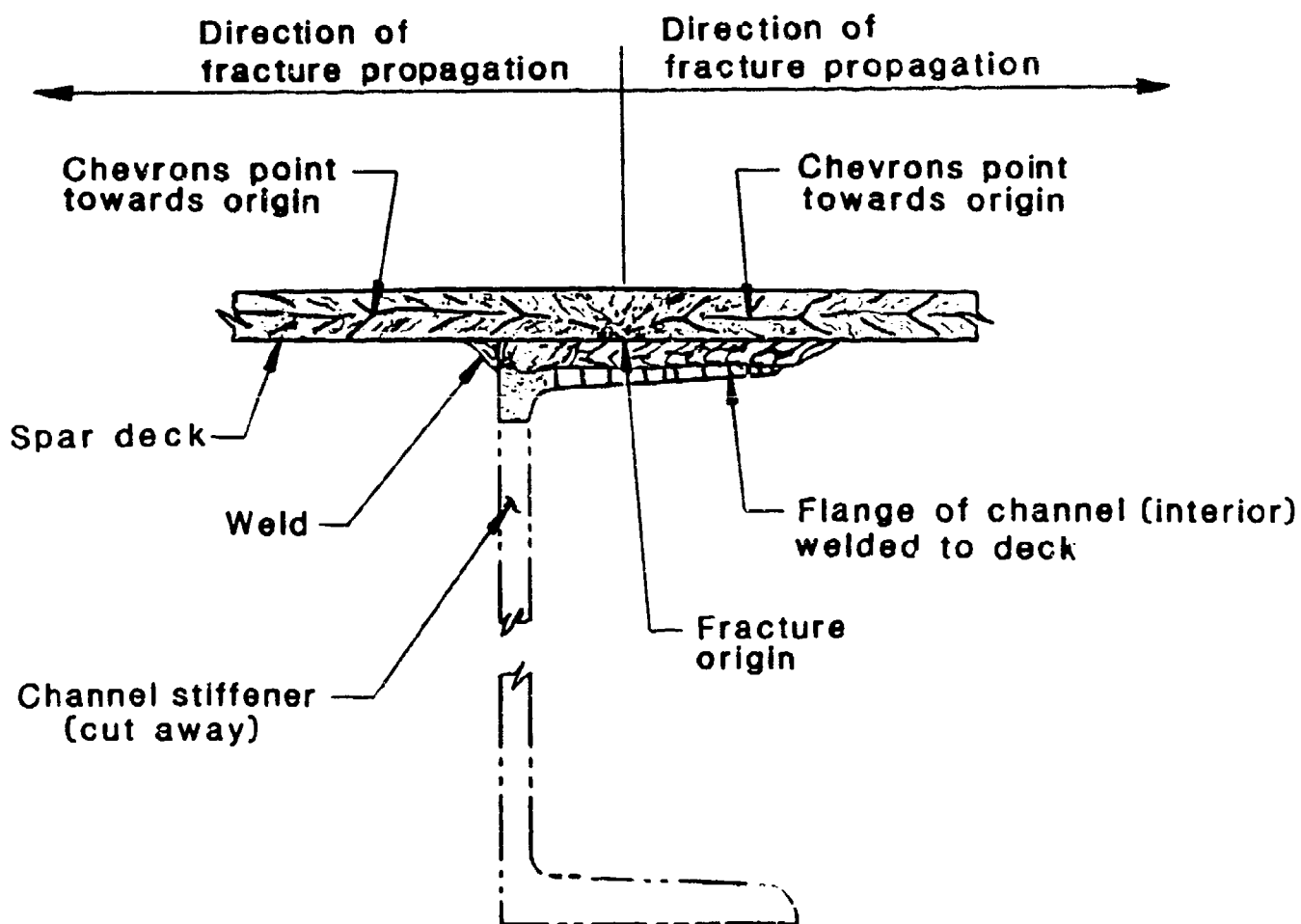
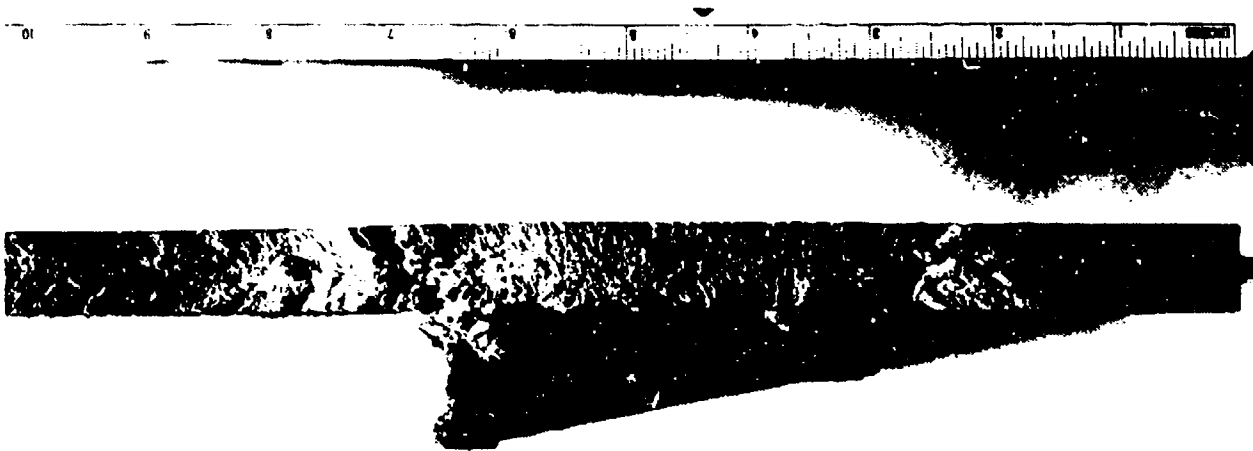

Figure 4-8. Location of the Fracture Origin in Sample No. 6.

weld of the flange cutout. The chevrons in the forward-most fracture in Sample 6 point outboard indicating that the fracture propagated inboard. The chevrons in the corresponding fracture in sample No. 7 point outboard indicating this fracture propagated inboard. Therefore, this fracture had to initiate somewhere between Samples Numbers 6 and 7, and shown in Figure 4-9 and probably at one of the two longitudinal flange cutouts.

Thus, the fractures in the spar deck originated at similar details: the flange cutout shown in Figure 4-5. This fabrication detail produced a severe transverse notch and stress concentration at each longitudinal.

The fracture in the longitudinal bulkhead originated in the butt weld of the angle riveted to the deck and longitudinal bulkhead. The two pieces of angle were poorly aligned, the weld was made from one side only and lacked depth of penetration. The toe of the angle was welded to the longitudinal bulkhead to fill a gap. Apparently this fracture initiated after the spar deck fractures and as the load path shifted to the longitudinal bulkhead. The angle butt weld cracked at a toe fillet weld which allowed the fracture to enter the longitudinal bulkhead. Figure 4-10 shows the fracture surface at the top of the longitudinal bulkhead, sample piece No. 3. The top middle of the photograph shows what remains of an angle toe fillet weld where the fracture entered the longitudinal bulkhead. From the fillet weld the fracture propagated up to the rivet hole and down the bulkhead.

Based on the direction of chevron markers on the fracture surfaces it can be concluded that the first fracture to form was that between samples No. 6 and 7. The crack between samples No. 6 and No. 9 formed next and then the one between samples No. 1 and 2. The bulkhead crack formed last. The path of fracture across the spar deck is as shown in Figure 4-11.

4.5 CAUSE OF THE SIGNIFICANT FRACTURES

The significant fractures all originated at longitudinals where the flange was cut for butt welding. The initiating defects at the origin were small. However, the ship operated for over 30 years with those poor fabrication details, suggesting relatively high forces in the ship structure from adverse weather at the time of fracture. This is also suggested by the multiple origin points. Because the fracture originated at poor fabrication details (notches), it is surprising that the ship survived in service for many years without fracturing.

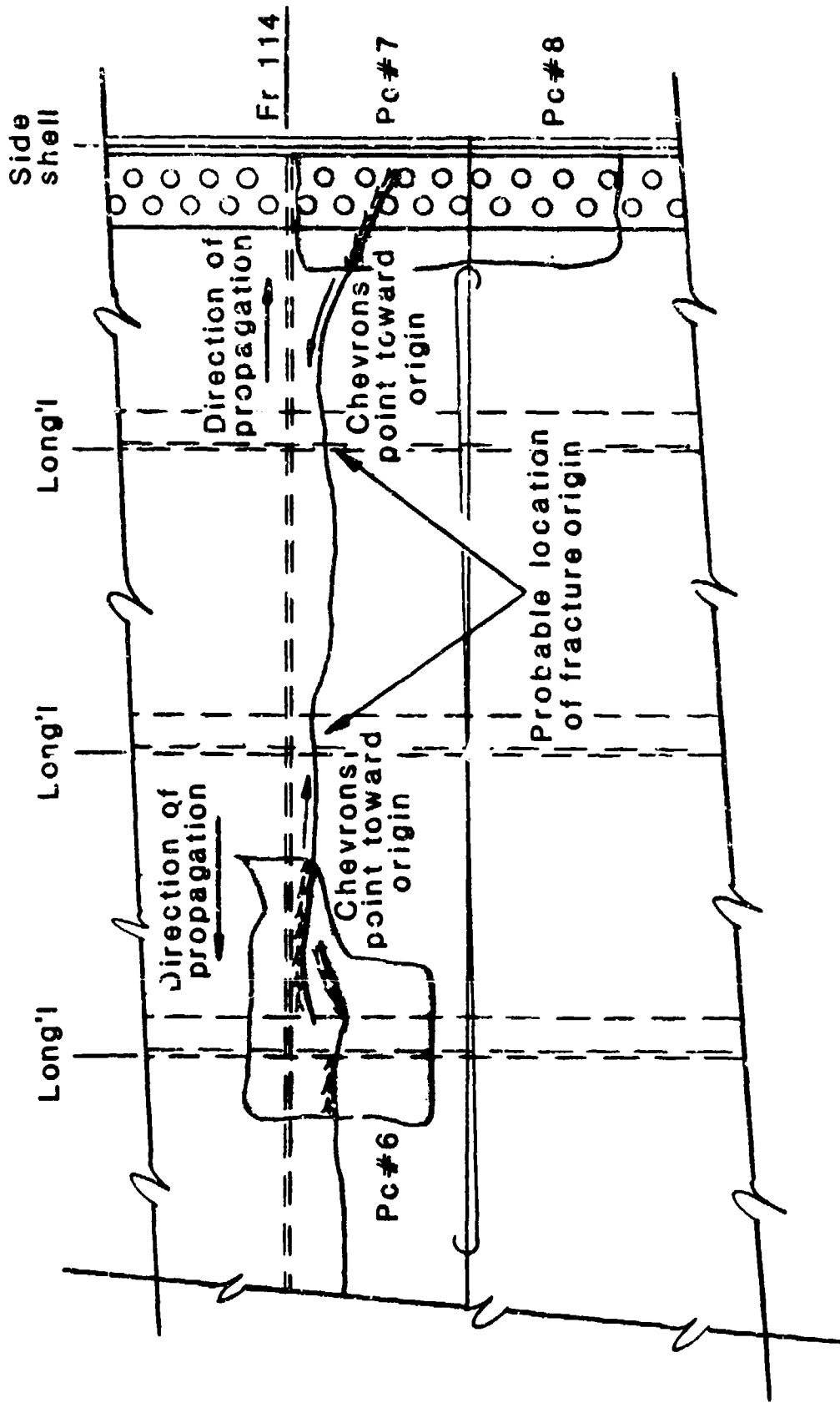

Figure 4-9. Fracture Propagation and Initiation between Sample No. 6 and No. 7.

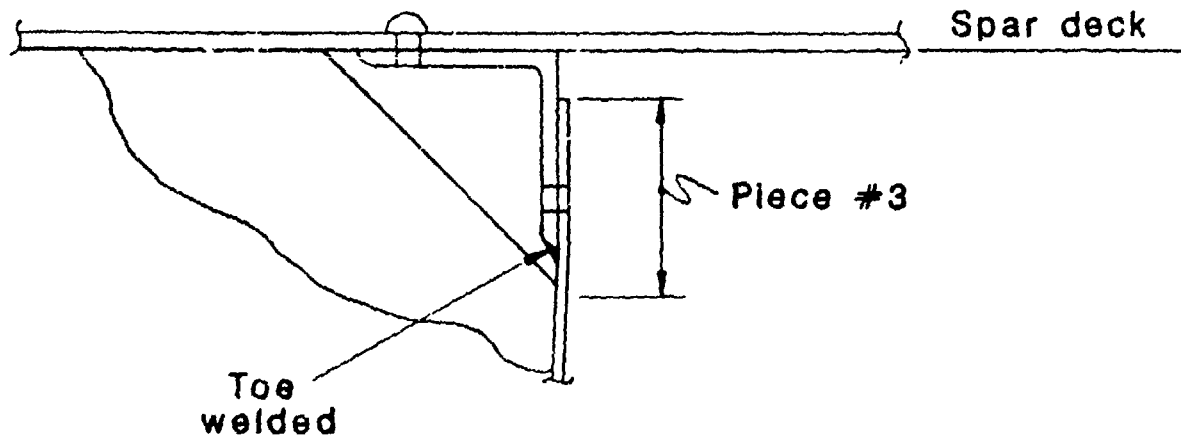
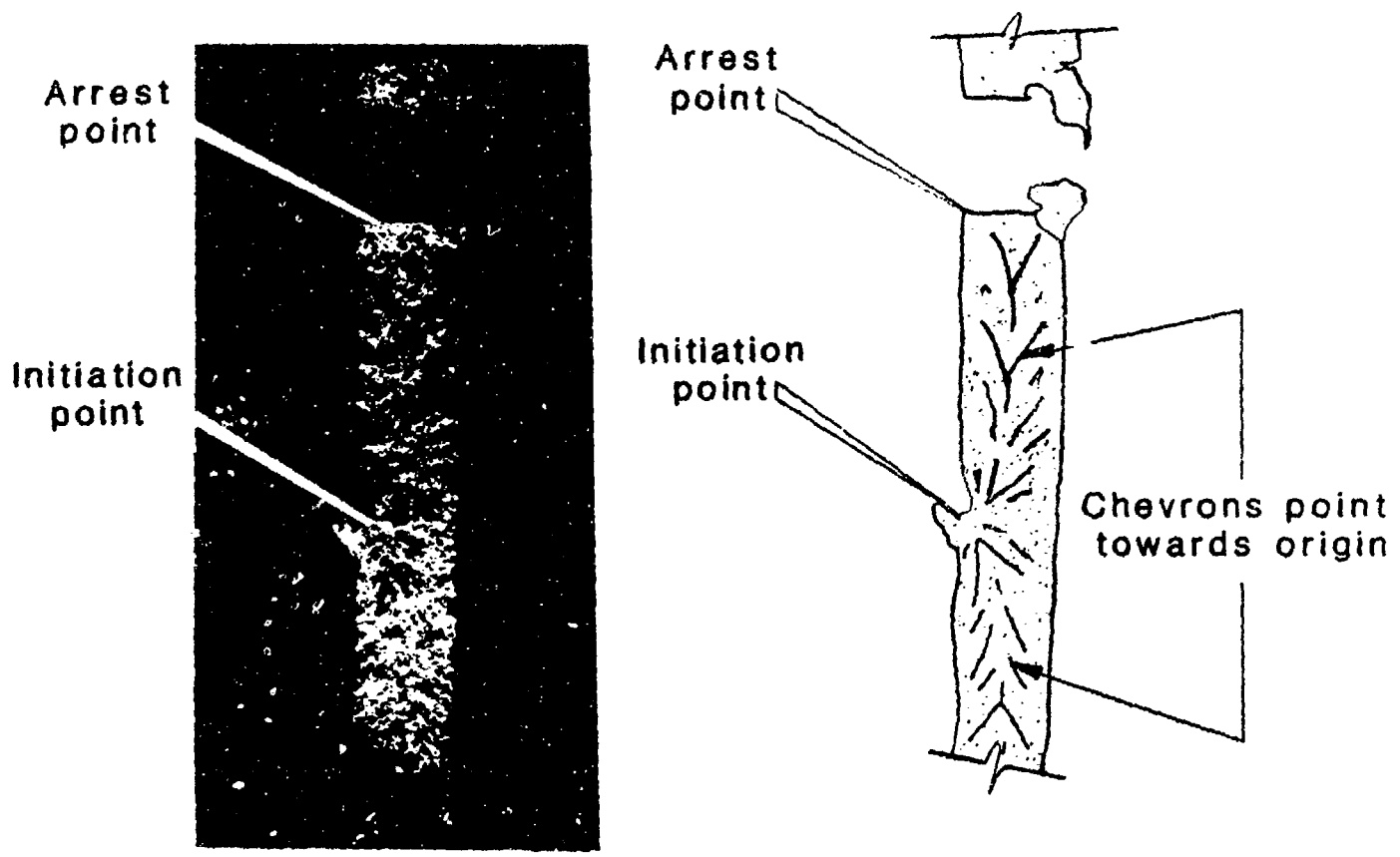

Figure 4-10. Piece No. 3 (Top of Longitudinal Bulkhead) Initiation Site Showing Crack Entering Piece No. 3 through Weld of Angle to Piece No. 3. Crack Goes to Rivet Hole on Right and Down the Bulkhead

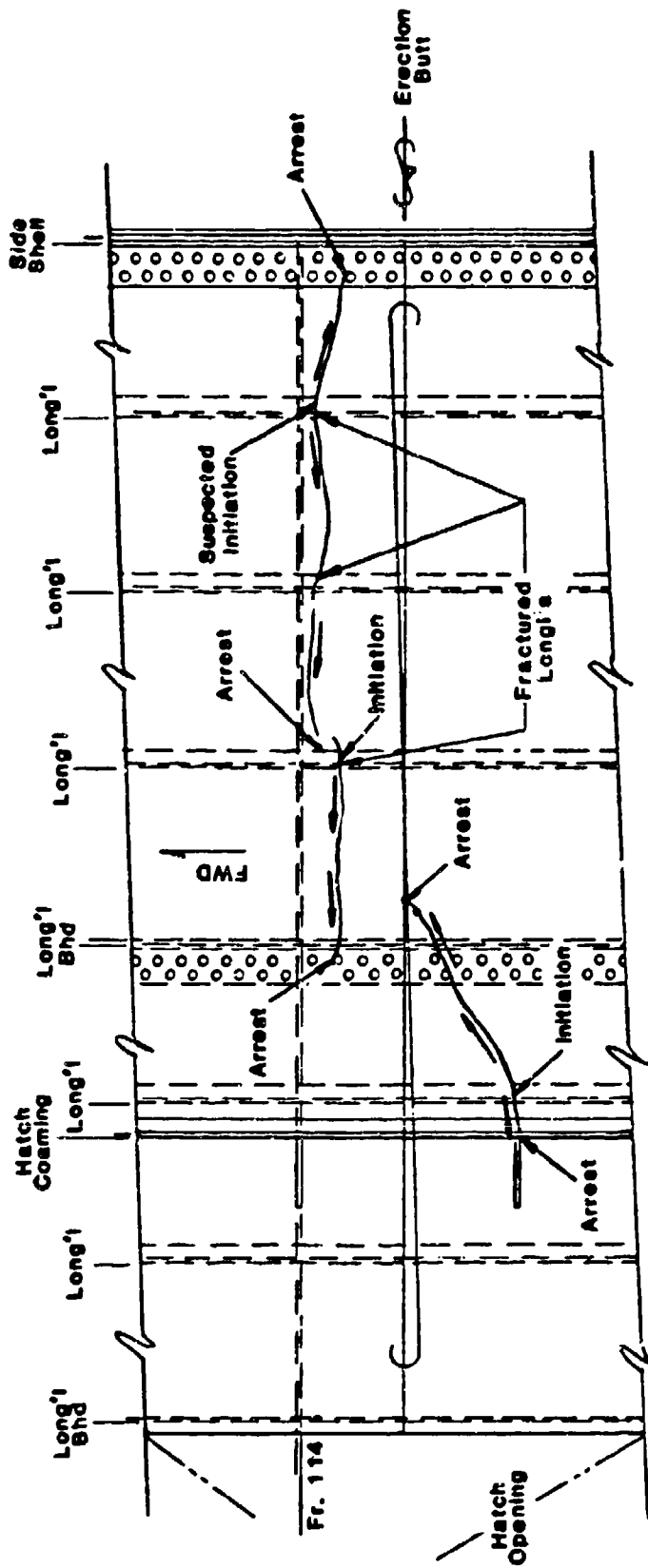

Figure 4-11. Plan of Spar Deck. Fracture Initiation and Arrest Points

5.0 GLOSSARY

This section contains definitions of the terminology commonly employed when studying ship fractures.

Alternate Loading: The change in the direction or magnitude of forces in the structure.

Arc Strike: A melting, solidification and rapid cooling that creates a severe flaw in the material. This occurs when a welder accidentally or intentionally strikes his energized welding rod to the steel in a location other than at the weld joint.

Arrest: The process of stopping a running crack or fracture.

Beach Marks: Marks on a fracture surface that resemble the marks left on a beach by waves. Beach marks are associated with fatigue fracture due to alternating forces.

Brittle: Describes the way some materials fail without first experiencing any appreciable deformation.

Brittle Fracture: An unstable fracture that propagates through steel structures almost instantaneously.

Charpy V-Notch Test: A destructive material test which measures the energy required to break a material specimen with a precut notch.

Chevron: A herringbone or "V"-shaped pattern that forms on a fracture surface during a brittle fracture. The points of the chevrons face back toward the origin of the fracture (see Figure 2-10).

Crack: A partial fracture of a material not resulting in a complete separation of the parts.

Delayed Cracks in Welds: Cracks which occur after uneven cooling or rapid cooling of weld metal during the welding process.

Ductile: Describes the way some materials deform before or during the fracture process.

Ductile Fracture: A stable fracture that propagates through steel structures gradually and is characterized by significant deformation of the metal crystals before fracture.

Dynamic Tear (DT) Test: A destructive material test which characterizes the crack tolerance of metals. The test specimen is notched and then pulled apart dynamically and starts a crack originating at the notch.

Elastic: Property of a material to deform under load and return to its original shape after the load is removed.

Failure Plane: The plane or surface created when a material cracks or fractures, similar to fracture surface.

Fatigue: The process causing material strength to deteriorate by subjecting it to many repeated alternate loadings.

Fatigue Cracking: The process of cracking which occurs after the material strength has been sufficiently deteriorated by alternating forces.

Flaw: A small defect that occurs in base material or welds. Flaws range in size from microscopic up to the full dimension of the structural member. Flaws may be created during material manufacture or fabrication.

Fracture: A break, split, or tear in a material which results in a complete separation of the material.

Fracture Mechanics: A field of engineering which deals with the fracture of materials in terms of structural parameters which can be directly measured or quantified.

Fracture Surface: The edge of a crack or fracture where the material has separated (similar to failure plane).

Initiation: Process of starting a crack or fracture in a material. The point where a crack or fracture initiates is called the origin.

Heat Affected Zone: The area of metal adjacent to a weld that has changed physical properties from the heat of the welding process.

Hydrogen Embrittlement: Embrittlement of a material caused by fast diffusion of hydrogen into the microstructure of metal adjacent to a weld. Hydrogen embrittlement can cause the initiation of a fracture because it makes the metal brittle.

Lack of Fusion: Inadequate bonding of weld metal to the base metal caused by low heat input during the welding process.

Lack of Weld Penetration: Incomplete penetration of weld filler metal in a welded joint.

Non-Destructive Testing (NDT): A test process that does not degrade the strength of the material being tested. NDT is used for the detection of flaws or cracks that are not visible to the unaided eye. Methods utilized include dye penetrants, magnetic particle, ultra-sonic or X-ray techniques.

Nil Ductility Temperature (NDT): The temperature at which a material experiences a transition from brittle behavior to ductile behavior.

Notch: A discontinuity in a material or structure which produces an area of stress concentration. Notches may be created during structural design or fabrication.

Nuisance Cracking: Small cracks that require frequent repair but do not constitute an immediate danger to the structure.

Origin: Location where a crack or fracture started. This location is not necessarily at the crack ends but may be in the center of a fracture. In these cases the fracture propagates in two directions from the origin. A flaw or notch of some type is usually found at a crack origin.

Plastic Deformation: Permanent deformation of a material or structure after it has been loaded beyond its elastic limit.

Porosity: A condition of gas entrapment during welding generally due to the presence of moisture on the surfaces to be welded.

Propagation: The growth of a crack or fracture.

Residual Stress: Stresses locked into a material or structure during manufacture, fabrication or welding. Large residual stresses can be caused by excessive heat input during welding, improper welding sequence and fitting procedures.

Shear: The force tending to make two connected parts or two adjacent crystalline structures slide in opposite directions in their plane of contact.

Shear Lip: The sharp edge of a fracture surface formed by shear slippage.

Slag Inclusion: Dirt, welding flux or other foreign material contaminating a weld.

Significant Fracture: A significant fracture propagates in an unstable (brittle) manner and extends through several structural members (e.g., plate and stiffeners).

Strain: A measure of the deformation of a material in terms of deflection per unit length.

Stress: Force per unit area of the cross-section of a structural member.

Stress Concentration: A local elevation in the magnitude of stress at a notch or flaw in the material or structure.

Striations: Lines that form on the face of a fatigue crack and are caused by alternating load (similar to beach marks).

Surface Contraction: A reduction in thickness of structure under tension prior to failure.

Tearing: The fracture of a material caused by pulling forces.

Termination: The location where a crack stops.

Toughness: The ability to deform or stretch without fracturing in the presence of a flaw or notch.

Triaxial Stress: A three-dimensional stress pattern at the tip of a flaw, notch or crack.

COMMITTEE ON MARINE STRUCTURES

Commission on Engineering and Technical Systems

National Academy of Sciences - National Research Council

The COMMITTEE ON MARINE STRUCTURES has technical cognizance over the interagency Ship Structure Committee's research program.

Stanley G. Stiansen (Chairman), Riverhead, NY
Mark Y. Berman, Amoco Production Company, Tulsa, OK
Peter A. Gale, Webb Institute of Naval Architecture, Glen Cove, NY
Rolf D. Glasfeld, General Dynamics Corporation, Groton, CT
William H. Hartt, Florida Atlantic University, Boca Raton, FL
Paul H. Wirsching, University of Arizona, Tucson, AZ
Alexander B. Stavovy, National Research Council, Washington, DC
Michael K. Parmelee, Secretary, Ship Structure Committee,
Washington, DC

LOADS WORK GROUP

Paul H. Wirsching (Chairman), University of Arizona, Tucson, AZ
Subrata K. Chakrabarti, Chicago Bridge and Iron Company, Plainfield, IL
Keith D. Hjelmstad, University of Illinois, Urbana, IL
Hsien Yun Jan, Martech Incorporated, Neshanic Station, NJ
Jack Y. K. Lou, Texas A & M University, College Station, TX
Naresh Maniar, M. Rosenthal & Son, Incorporated, New York, NY
Solomon C. S. Yim, Oregon State University, Corvallis, OR

MATERIALS WORK GROUP

William H. Hartt (Chairman), Florida Atlantic University, Boca Raton, FL
Fereshteh Ebrahimi, University of Florida, Gainesville, FL
Santiago Ibarra, Jr., Amoco Corporation, Naperville, IL
Paul A. Lagace, Massachusetts Institute of Technology, Cambridge, MA
John Landes, University of Tennessee, Knoxville, TN
Mamdouh M. Salama, Conoco Incorporated, Ponca City, OK
James M. Sawhill, Jr., Newport News Shipbuilding, Newport News, VA

SHIP STRUCTURE COMMITTEE PUBLICATIONS

- SSC-324 Analytical Techniques for Predicting Grounded Ship Response by J. D. Porricelli and J. H. Boyd, 1984
- SSC-325 Correlation of Theoretical and Measured Hydrodynamic Pressures for the SL-7 Containership and the Great Lakes Bulk Carrier S. J. Cort by H. H. Chen, Y. S. Shin & I. S. Aulakh, 1984
- SSC-326 Long-Term Corrosion Fatigue of Welded Marine Steels by O. H. Burnside, S. J. Hudak, E. Oelkers, K. B. Chan, and R. J. Dexter, 1984
- SSC-327 Investigation of Steels for Improved Weldability in Ship Construction by L. J. Cuddy, J. S. Lally and L. F. Porter 1985
- SSC-328 Fracture Control for Fixed Offshore Structures by P. M. Besuner, K. Ortiz, J. M. Thomas and S. D. Adams 1985
- SSC-329 Ice Loads and Ship Response to Ice by J. W. St. John, C. Daley, and H. Blount, 1985
- SSC-330 Practical Guide for Shipboard Vibration Control by E. F. Noonan, G. P. Antonides and W. A. Woods, 1985
- SSC-331 Design Guide for Ship Structural Details by C. R. Jordan and R. P. Krumpen, Jr., 1985
- SSC-332 Guide for Ship Structural Inspections by Nedret S. Basar & Victor W. Jovino, 1985
- SSC-333 Advance Methods for Ship Motion and Wave Load Prediction by William J. Walsh, Brian N. Leis, and J. Y. Yung, 1989
- SSC-334 Influence of Weld Porosity on the Integrity of Marine Structures by William J. Walsh, Brian N. Leis, and J. Y. Yung, 1989
- SSC-335 Performance of Underwater Weldments by R. J. Dexter, E. B. Norris, W. R. Schick, P. D. Watson, 1986
- SSC-336 Liquid Slosh Loading in Slack Ship Tanks; Forces on Internal Structures & Pressures by N. A. Hamlin, 1986
- SSC-337 Ship Fracture Mechanisms Investigation (Parts 1 and 2) by Karl A. Stambaugh and William A. Wood, 1987
- None Ship Structure Committee Publications - A Special Bibliography, 1983