

2

AFOEHL REPORT 90-204EI00461LVA



AD-A231 331

Ventilation for Composites Repair Facility
McClellan AFB CA

JOHN F. SEIBERT, Maj, USAF, BSC

DTIC FILE COPY

DTIC
ELECTE
JAN 30 1991
S D D

November 1990

Final Report

Distribution is unlimited; approved for public release

AF Occupational and Environmental Health Laboratory (AFSC)
Human Systems Division
Brooks Air Force Base, Texas 78235-5501

91 1 29

104

NOTICES

When Government drawings, specifications, or other data are used for any purpose other than a definitely related Government procurement operation, the Government incurs no responsibility or any obligation whatsoever. The fact that the Government may have formulated, or in any way supplied the drawing, specifications, or other data, is not to be regarded by implication, or otherwise, as in any manner licensing the holder or any other person or corporation; or conveying any rights or permission to manufacture, use, or sell any patented invention that may in any way be related thereto.

The mention of trade names or commercial products in this publication is for illustration purposes and does not constitute endorsement or recommendation for use by the United States Air Force.

The Public Affairs Office has reviewed this report, and it is releasable to the National Technical Information Service, where it will be available to the general public, including foreign nations.

This report has been reviewed and is approved for publication.

Air Force installations may direct requests for copies of this report to: Air Force Occupational and Environmental Health Laboratory (AFOEHL) Library, Brooks AFB TX 78235-5501.

Other Government agencies and their contractors registered with the DTIC should direct requests for copies of this report to: Defense Technical Information Center (DTIC), Cameron Station, Alexandria VA 22304-6145.

Non-Government agencies may purchase copies of this report from: National Technical Information Service (NTIS), 5285 Port Royal Road, Springfield VA 22161

JOHN F. SEIBERT, Maj, USAF, BSC
Chief, Industrial Hygiene Branch

EDWIN C. BANNER III, Col, USAF, BSC
Chief, Environmental Quality Division

REPORT DOCUMENTATION PAGE

Form Approved
OMB No. 0704-0188

Public reporting burden for this collection of information is estimated to average 1 hour per response, including the time for reviewing instructions, searching existing data sources, gathering and maintaining the data needed, and completing and reviewing the collection of information. Send comments regarding this burden estimate or any other aspect of this collection of information, including suggestions for reducing this burden, to Washington Headquarters Services, Directorate for Information Operations and Reports, 1215 Jefferson Davis Highway, Suite 1204, Arlington, VA 22202-4302, and to the Office of Management and Budget, Paperwork Reduction Project (0704-0188), Washington, DC 20503

1. AGENCY USE ONLY (Leave blank)		2. REPORT DATE November 1990	3. REPORT TYPE AND DATES COVERED Final	
4. TITLE AND SUBTITLE Ventilation for Composites Repair Facility, McClellan AFB CA			5. FUNDING NUMBERS	
6. AUTHOR(S) John F. Seibert, Maj, USAF, BSC				
7. PERFORMING ORGANIZATION NAME(S) AND ADDRESS(ES) AF Occupational and Environmental Health Laboratory Brooks AFB TX 78235-5501			8. PERFORMING ORGANIZATION REPORT NUMBER AFOEHL Report 90-204EI00461LVA	
9. SPONSORING/MONITORING AGENCY NAME(S) AND ADDRESS(ES) Same as Blk 7			10. SPONSORING/MONITORING AGENCY REPORT NUMBER	
11. SUPPLEMENTARY NOTES				
12a. DISTRIBUTION/AVAILABILITY STATEMENT Statement A. Unlimited, approved for public release			12b. DISTRIBUTION CODE	
13. ABSTRACT (Maximum 200 words) Repairing damaged fiberglass, carbon and Kevlar composites generate dust and debris during sanding and grinding. While potentially only a skin and eye irritation hazard, control of the dust leads to more satisfied workers and a better product. Dust can be controlled through a set of ventilation exhaust systems to include: high velocity low volume exhaust on the sanding tool, a downdraft sanding table, and a flex-hose dust exhaust system for large parts. This report describes those systems and other accessories useful in composite repairs.				
14. SUBJECT TERMS Carbon Composites, Advanced Composites Fiberglass Ventilation, Local Exhaust Dust, McClellan AFB CA Seibert			15. NUMBER OF PAGES 44	
			16. PRICE CODE	
17. SECURITY CLASSIFICATION OF REPORT Unclassified	18. SECURITY CLASSIFICATION OF THIS PAGE Unclassified	19. SECURITY CLASSIFICATION OF ABSTRACT Unclassified	20. LIMITATION OF ABSTRACT none	

(This page left blank)

ACKNOWLEDGEMENT

We appreciate the time and efforts of 2Lt Timothy Devine, USAF Clinic McClellan/SGPB, for arranging the tour of the McClellan AFB composites facilities and photographic support. We also appreciate the generosity of Mr Daryl Moore and Mr Nick Wienholz, SM-ALC/TIMCH-2, in showing us composite repair techniques and equipment, and in offering their assistance to all Air Force composite repair facilities.

Accession For	
NTIS CRA&I	<input checked="" type="checkbox"/>
DIC TAB	<input type="checkbox"/>
Unannounced	<input type="checkbox"/>
Justification	
By	
Distribution	
Availability Codes	
Dist	Avail and/or Special
A-1	



CONTENTS

	Page
Standard Form 298 Acknowledgement	i iii
I. INTRODUCTION	1
II. DISCUSSION	1
III. RECOMMENDATIONS	3
REFERENCES	4
Appendix	
A SM-ALC Fiberglass Protection Plan	5
B SM-ALC Ventilation Systems	17
C Composite Repair Equipment List	23
D Exhaust Ventilation System Design	27
Distribution List	39

I. INTRODUCTION:

A. Purpose: This technical report recommends ventilation and other specialized tools for a composites repair facility for the 129 Consolidated Aircraft Maintenance Squadron (CAMS) in the repair of glass, Kevlar^R, and carbon composites. Information included was extracted from the experiences of composites repair facilities at SM-ALC, McClellan AFB, and applied to the operational needs of the 129 CAMS.

B. Problem: The existing 129 CAMS fiberglass repair room is used for sanding, grinding and layup of fiberglass parts on the H-3 helicopter. Ventilation for this room has been determined to be inadequate by the 129 TAC Clinic/SGPB, with an assigned Risk Assessment Code (RAC) 3. The 129th Air Rescue Squadron (ARS) is converting from H-3 to MH-60 Pave Hawk helicopters. The H-60 has components containing fiberglass, Kevlar and carbon composites, which must be repaired by the 129 CAMS. SM-ALC/MAN, McClellan AFB, has extensive experience with composite repair, and can be used as an example of how to set up and operate a composites repair facility.

C. Scope: This report was written for the 129 CAMS, but can be used by as a guide for ventilation for any composite repair facility to minimize exposures to dust and vapors from composite repair operations.

II. DISCUSSION

A. Potential options for repairing H-60 composites are: 129 CAMS personnel repair composites at 129 CAMS facilities with a fiberglass room; SM-ALC/MAN personnel repair composites at McClellan AFB facilities with funding from 129 CAMS; and 129 CAMS personnel repair composites at McClellan AFB facilities. While these options were discussed during the visit, this survey report only addresses the technical requirements for 129 CAMS personnel performing composite work at 129 CAMS facilities.

B. Current composite repair operations include sanding, grinding and wet lay-up operations on fiberglass parts on a workbench in a room approximately 10 ft x 10 ft x 8 ft. The only source of ventilation is a flex hose connected to a 12" x 3" unflanged hood providing 1060 cubic feet per minute (cfm) of exhaust air flow. Make-up air is returned passively through the room door. With the exhaust hood resting on the bench top, a theoretical capture velocity of 100 feet per minute (fpm) is achieved at 1.4 ft from the face of the hood. This is the effective capture zone for vapors and stationary dust particles. Dust ejected during sanding or grinding will require higher air capture velocities proportional to tool surface speed.

C. H-60 composite parts contain predominantly Kevlar and fiberglass composites, with minor quantities of carbon composites. Review of available literature indicates Kevlar repair procedures are similar to procedures already in use for fiberglass repair. Repair operations include: sanding/grinding out the damaged area of the part, mixing the epoxy resin with hardener, wet layup of the resin system with Kevlar or fiberglass, allowing to cure at room temperature or under heat lamps/blankets, and sanding/drilling of the finished part. By contrast, carbon composites use a premixed "prepreg" patch or tape of mixed and partially reacted resin system imbedded with carbon fibers. Curing carbon composites requires heat and

pressure. Facility requirements remain essentially unchanged from current operations:

1. Refrigerated storage of resin systems or "prepreg" patches/tapes to maximize shelf life.
2. Local exhaust ventilation to capture and remove dust from sanding/grinding of damaged area and for final finishing of completed part.
3. Local exhaust ventilation to capture and remove solvent vapors from parts cleaning.
4. General dilution ventilation to remove irritating odors during epoxy system curing.
5. Vacuum exhaust system for clean up of dust not captured by exhaust ventilation during sanding/grinding.

D. Maj Seibert, Capt Pinkerton, SMSgt Badertcher and TSgt Stephens traveled to McClellan AFB to tour composite repair facilities, to establish a working relationship between 129 CAMS and SM-ALC/MAN personnel, and get ideas for ventilation, personnel protective equipment, composite repair techniques and composite repair equipment and supply needs. 2Lt Devine, USAF Clinic McClellan/SGB, guided us through the composites facilities, giving details of problems encountered and solutions found when setting up facilities for composites repairs. He also had product information on portable exhaust ventilation systems which could be used to exhaust and collect dust during composite sanding. Mr Daryl Moore and Mr Nick Wienholz, SM-ALC/TIMCH-2, DSN 633-5515, were extremely helpful in explaining types and methods of composite repair, engineering controls, personal protective equipment, and equipment and supplies ordering information (see list, Appendix C). Mr Wienholz stated he considers his shop an Air Force resource in assisting composites repair facilities with questions on techniques and equipment that work, and equipment and supplies ordering information. Workplace controls being used successfully at McClellan include:

1. Tools: The "Dotco" orbital sanders in use at McClellan have high velocity low volume exhaust ventilation built into the face of the sanding disk for removing dust at the work surface (Appendix B, Figure B-2). Exhaust air is provided by Nilfisk type GS82-56105 industrial vacuum cleaners with High Efficiency Particulate Absolute (HEPA) filters to remove the smallest dust particles (Figure B-3). Smaller sanders do not have exhaust ventilation installed.

2. Exhaust Ventilation Systems: Sanding is performed on downdraft grinding tables, which provide approximately 150 fpm of downward air flow to pull dust away from the part being sanded and the worker (Figure B-1). Exhaust air is provided by 10" ducts leading to an exterior exhaust fan with dust extraction system.

3. Personal Protective Equipment (PPE): During composite sanding, personnel wear safety glasses, nuisance dust respirators, Tyvek disposable coveralls, and leather gloves to prevent eye, skin and lung irritation caused

by the composite dust. Health effects more severe than normally expected from inhalation of nuisance dusts have not been found to date.

E. A review of existing 129 CAMS facilities and previous contractor ventilation proposals indicated a wide range of possibilities for types and location of ventilation systems to remove airborne dust and vapors. Exhaust ventilation should be sized to the size and location of parts to be repaired. Parts which could require repair include: removable composite parts covering a benchtop work area less than 3 ft x 3 ft; 4 ft x 8 ft cargo bay floor panels, and helicopter rotor blades exceeding 20 ft in length. Based on the variety of parts sizes, either a single highly flexible ventilation system, or several specialized ventilation systems are needed.

F. Ventilation:

1. Resin mixing and wet lay-up operations generate vapors, but no dust, and are best performed in a relatively dust free area away from sanding operations. The existing spray paint booth next to the proposed composites repair room could be used for this operation.

2. Sanding on parts less than 3 ft by 3 ft within the shop are best performed on a downdraft sanding/grinding table which removes dust from the part and the worker. Using a sander with built in vacuum exhaust enhances dust removal.

3. Sanding on larger parts in the shop, outdoors or installed on the helicopter could be performed with a portable exhaust ventilation system with flexible hose. While not as effective at capturing and removing dust as a grinding table, it is the best compromise available for large parts.

III. RECOMMENDATIONS:

A. Perform resin mixing and wet lay-up operations in the existing Corrosion Control spray paint booth. Sand small parts on a downdraft grinding table (Appendix D). Sand larger parts while using a portable flex-hose exhaust system (Appendix D).

B. Purchase sanders with built-in exhaust ventilation capability, a Nilfisk vacuum cleaner with HEPA filter and a portable flex-hose exhaust ventilation system with dust removal and HEPA filter.

C. Purchase personal protective equipment to prevent skin and eye irritation from dust exposure, and specialized composite repair gloves to prevent skin exposure to uncured resins.

D. Purchase and install a sanding table in the proposed "fiberglass room".

E. Use SM-ALC/TIMCH-2 as a resource for training and for ordering supplies and materials.

REFERENCES

1. Industrial Ventilation, A Manual of Recommended Practice, American Conference of Governmental Industrial Hygienists (ACGIH), 20th edition (1988).
2. SM-ALC/MAN Fiberglass Personnel Protection Plan, McClellan AFB (Appendix A).

APPENDIX A

SM-ALC Fiberglass Protection Plan

(This page left blank)

MAN FIBERGLASS PROTECTION PLAN

In order to provide a safe working environment in MAN shops working with fiberglass, this mandatory Fiberglass Protection Plan will be implemented and will supersede any plans previously approved. The plan provides for Personal Protective Equipment (PPE) and special equipment to reduce or eliminate employees exposure to fiberglass particles. The areas covered by this plan are designated in Bldgs. 243B, 243C, 243E, 440 and 475F. Personal Protective Equipment (PPE) requirements may be changed in the future by SGB based on the results of periodic surveys and/or operational changes. Any changes that require negotiation will be sent to AFGE prior to implementation.

	<u>Section</u>
Division Policy on Fiberglass Protection	1
Personal Protective Equipment (PPE) Requirements	2
Ordering, Issue, Storage and Disposal of PPE	3
Visitor Control	4
Designated Fiberglass Work Areas	5
Approved List and Use of PPE	6

1 Atch
MAN Fiberglass Protection
Plan Briefing

1. DIVISION POLICY ON FIBERGLASS PROTECTION

a. The protection and safety of employees in the work area is of prime importance to MAN management. This plan was developed to further reduce or eliminate the possible exposure of employees to fiberglass particles. The plan provides for centralizing fiberglass operations (reducing the number of people potentially exposed), improving environmental controls in fiberglass work areas (limiting the possibility of fiberglass dust migration and improving worker comfort), and removing personal protective equipment requirements when no longer required. This plan implements guidance provided by SGB.

b. Each supervisor and employee is responsible for implementation and enforcement of this plan. To ensure employees are briefed on what is expected of them, the attached briefing sheet (ATCH 1) will be used by the supervisor for the PPE orientation briefing. After the briefing, each employee will sign the briefing sheet and it will be filed in his/her 971.

c. The use of protective equipment is mandatory where required. If an employee fails to use or abuses the protective equipment, appropriate corrective action may be taken.

d. Personal protective equipment requirements for areas other than those specifically referenced in this fiberglass protection plan will revert to those required for that industrial area or task.

2. PERSONAL PROTECTIVE EQUIPMENT (PPE) REQUIREMENTS

In order to reduce potential fiberglass exposure to employees and visitors, the following restrictions and personal protective equipment (PPE) requirements will apply in Bldgs. 243B, 243C, 243D, 440 and 475F (Fiberglass Work Areas Only). MANP is responsible for the enforcement of this fiberglass protection plan.

a. Operations that produce airborne fiberglass particles will be performed only in the designated fiberglass work areas.

b. Access will be limited to employees and visitors required by their duties to enter these areas.

c. Posted warnings:

(1) Signs will be posted on the perimeter of the PPE area stating the following: "THIS AREA IS A CONTROLLED AREA. SEE FOREMAN FOR APPROPRIATE PROTECTIVE CLOTHING." These areas will be posted when fiberglass operations are being conducted. When operations cease, the areas will be cleaned and signs removed or covered (i.e., no fiberglass operation, no PPE).

(2) Around the two permanent fiberglass sanding rooms, 243E, a permanent sign will be painted on all doors and labeled "CONTROLLED AREA - PROTECTIVE CLOTHING REQUIRED."

d. The following housekeeping procedures will be used:

- (1) Employees will clean their area at least twice daily.
- (2) Employees will clean after each job, as needed, and before lunch and break periods, if possible. For jobs lasting several hours, workers will clean as often as necessary to prevent excess accumulation of dust.
- (3) Tables and other elevated surfaces will be cleaned of dust either by vacuuming or by use of a damp cloth.
- (4) Floors will be cleaned on a regular basis or sooner if required by either wet mopping, vacuuming, or by use of dry-sweeping compounds and push brooms. Floor scrubbers will be used to clean the general shop area where access permits.

e. The following personal protective equipment (PPE) procedures apply:

- (1) Disposable coveralls will be worn by all employees and visitors prior to entering these areas. Visitors include anyone entering those designated fiberglass PPE areas.
 - (a) Coveralls will be worn with zipper completely closed, and sleeve and legs fully extended.
 - (b) Small tears and holes will be mended with tape. The coverall may be tucked and taped to take-up loose material in the midsection.
 - (c) Elastic bands on the cuffs will not be cut or altered.
 - (d) The coverall will not be cut or altered to create pockets, provide access to pockets underneath, or modify and/or remove the collar or zipper.
 - (e) The coverall will not be washed, soaked, dyed or worn inside out.
 - (f) Coveralls may be worn to other areas except when specifically prohibited.
 - (g) Only a security badge will be worn on the coverall itself.
 - (h) A shop apron may be worn to protect coveralls from abrasion, solvents, or to provide pockets.
 - (i) Coveralls will not be taken home and will be removed and properly stored or discarded at the end of the work period. Discarded coveralls will not be reused for any other purpose.
 - (j) Disposable coveralls will be stored in lockers provided near the shop area.

(k) Supervisory personnel, planners, and engineers who come into the PPE area on a periodic basis may store coveralls in their work area.

(l) Visitor PPE will be issued and stored by the shop supervisor (work leader in Bldg. 440 and 475F). Visitors should return PPE to the shop supervisor upon leaving the area. Foremen will ensure that visitor PPE is returned and properly stored or disposed of when appropriate.

(m) Employee coveralls will be issued from specified storage areas near the shop area. Supervisors are responsible for monitoring frequency of use of PPE, and taking corrective action to prevent abuse.

(n) Disposable coveralls will be discarded in barrels lined with plastic bags located in the shop area. The plastic bags will be sealed and disposed of daily in the Dempsey Dumpster. Supervisors are responsible for ensuring that PPE is disposed of properly.

(2) Gloves, dust mask to prevent facial irritation and goggles will also be worn in addition to coveralls when performing sanding, cutting, grinding or any other operation that produces airborne fiberglass particles.

(3) Safety glasses are not required for use under the goggles, but must be worn in the area when not wearing goggles.

(4) The use of barrier cream is optional.

(5) Any alterations to the PPE currently prescribed will be made only on approval of SGB, SEO and Section Chief.

(6) Any changes to the Personal Protective Equipment requirements currently prescribed will be made only on approval of SGB, SEO and Section Chief and will be negotiated with the Union.

(7) Supervisors are responsible for implementing and enforcing the use of PPE.

f. Eating, drinking and smoking are not permitted in the fiberglass work areas.

g. Food, beverages, eating or drinking utensils, tobacco products or personal clothing will not be stored in the fiberglass work areas.

h. All personnel working in Fiberglass work areas other than Bldg. 243E where air showers are located will vacuum their coveralls before going on break, washroom or at the end of the shift. Personnel in Bldg. 243E will use the air shower.

i. Any grinding or sanding of fiberglass or adhesives that contain fiberglass will utilize vacuum hoods, local exhaust (HVLV or vacuum producer) or portable high vacuum systems.

j. To reduce the fiberglass dust level in Bldg. 440 to a tolerable level on the 396 Radome Repair Project, the panels will be coated with resin prior to any sanding operation.

3. ORDERING, ISSUE, STORAGE AND DISPOSAL OF PPE

a. Bioenvironmental Engineering (SGB) recommends the following protective equipment be used in fiberglass work situations: disposable coveralls (or equivalent), goggles, dust mask to prevent facial irritation and leather and/or rubber gloves. Except for the disposable coveralls, all items are authorized by Table of Allowance 016. MANSM is responsible for ensuring a 90 day stock level is maintained on all equipment. MANP will provide MANSM with usage rates and size requirements for ordering the PPE. MANSM is responsible for ordering PPE, establishing Table of Allowance Authorization, and provide a requirements contract for disposable coveralls.

b. Disposable coveralls, goggles, dust mask to prevent facial irritation, leather and/or rubber gloves and optional shop aprons will be issued by the shop supervisor or the alternate. Supervisors are responsible for monitoring PPE usage and taking corrective action to prevent abuse.

c. Disposable coveralls will be stored in designated lockers. Supervisors will ensure that coveralls are not stored in tool cabinets or taken home. All visitor(s) coveralls will be issued and stored by the shop supervisor.

d. Disposable coveralls will be discarded in barrels lined with plastic bags. The plastic bags will be sealed and disposed of daily in the Dempsey Dumpster outside Bldg. 243. Supervisors are responsible for ensuring that PPE is disposed of properly. Discarded coveralls will not be reused for any purpose or taken home by employees.

4. VISITOR CONTROL

a. Visitors include anyone entering the designated areas when fiberglass operations are in progress. Visitors must contact shop supervisors to obtain PPE and will put it on before entering the work area.

b. Each supervisor is responsible for obtaining coveralls to issue to visitors. It is the supervisor's responsibility to collect coveralls from visitors and either store them or discard if in poor condition. Routine visitors (i.e., planners, engineers, schedulers, etc.) may store their PPE in their work area. Visitors will vacuum coveralls prior to leaving the area (either using a vacuum cleaner or a walk through personnel cleaner if available). All personnel assigned to the fiberglass work area share in the responsibility to monitor the protection of visitors.

5. DESIGNATED FIBERGLASS WORK AREAS

a. Bldg. 243B. When a fiberglass machining project is occasionally undertaken by the Manufacturing Section (MANPBE and/or MANPBJ) in Bldg. 243B, a ten (10) foot radius will be roped off around the designated equipment along with the appropriate signs denoting the roped off area as a fiberglass work area. All fiberglass PPE requirements and restrictions will be enforced until this fiberglass work area is cleaned up and is no longer designated a fiberglass work area.

b. Bldg. 243C. When fiberglass project is undertaken by the Foundry Unit in Bldg. 243C, a five to ten ft. radius will be roped off around the foundry bandsaws and the entry way to the Pattern Shop will also be roped off. These roped off areas will have appropriate signs denoting the roped off areas as fiberglass work areas. All fiberglass PPE requirements and restrictions will be enforced until this fiberglass work area is cleaned up and is no longer designated fiberglass work area.

c. Bldg. 243E. The two permanent sanding rooms in Bldg. 243E are designated as permanent fiberglass work areas. All fiberglass PPE requirements and restrictions will be enforced at all time.

d. Bldfg. 440. When the 396 Radome Project is worked in the NW part of Bldg. 440 involving the sanding of fiberglass by the MAN Plastic Manufacturing Unit (MANPFE), the entrances will be roped off and appropriate signs denoting this area as a fiberglass work area. All fiberglass PPE requirements and restrictions will be enforced until this fiberglass work area is cleaned up and is no longer designated a fiberglass work area. An additional restriction to reduce the fiberglass dust level, in Bldg. 440 to a tolerable level, in Bldg. 440 to a tolerable level is to have the panels coated with resin prior to any sanding operations.

e. Bldg. 475F. When a fiberglass project is undertaken by the MAN Routed Repair Unit (MANPAN) in Bldg. 475F, a designated fiberglass work area will be roped off with appropriate signs denoting this area as a fiberglass work area. At least ten (10) feet will be required between the actual sanding and/or work and the boundary rope. All fiberglass PPE requirements and restrictions will be enforced until this fiberglass work area is cleaned up and is not longer designated a fiberglass work area.

6. APPROVED LIST AND USE OF PPE

a. General: The following guidelines describe the basic requirements for use of fiberglass PPE:

(1) Disposable coveralls will be worn in the designated fiberglass work area.

(2) Gloves, dust mask and goggles will be worn when performing sanding, cutting or grinding operations on fiberglass.

(3) A shop apron may be worn to protect coveralls from abrasion, solvents, or to provide pockets.

b. Coveralls

(1) Small	8415L0007692047 *
(2) Medium	8415L0007702047 *
(3) Large	8415L0007712047 *
(4) X-Large	8415L0015382047 *
(5) XX-Large	8415L0007732047 *

c. Dust Mask 4240 00 629 8199 *

d. Goggles	4240 P 460 236 *
e. Leather Gloves	
(1) Size 3	8415 00 268 7869 *
(2) Size 2	8415 00 268 7872 *
f. Rubber Gloves	
(1) Size 11	8415 00 641 4601 *
(2) Size 10	8415 00 641 4600 *
g. Apron, welder	8415 00 250 2531 *

* Stock Numbers are subject to routine data system changes with no physical change in the item.

MAN FIBERGLASS PROTECTION PLAN BRIEFING

1. POLICY. The use of PPE is mandatory in the designated PPE work areas. You and your supervisor share the responsibility for implementing the MAN Fiberglass Protection Plan. Any abuse or failure to use PPE will result in corrective action.

2. PERSONAL PROTECTIVE EQUIPMENT (PPE):

- a. Disposable Coveralls - wear in all designated fiberglass work areas.
- b. Dust Mask, Goggles and Gloves - wear when grinding, drilling or sanding fiberglass in designated work areas.
- c. Shop Apron - may be worn to protect coveralls from abrasion, solvents or to provide pockets.
- d. Eating, drinking, and/or smoking in designated fiberglass work areas are not permitted.
- e. Repair small holes and tears in coveralls with tape.
- f. Alteration of coveralls prohibited unless otherwise directed.

3. HOUSEKEEPING AND DUST SUPPRESSION:

- a. Clean work area at least twice daily. This will be accomplished by wet mopping, vacuuming or by using dry-sweeping compound and push brooms.
- b. Clean after each job
- c. Clean before break, lunch and end of shift

4. ISSUE, STORAGE AND DISPOSAL OF PPE:

- a. Issued by Foreman
- b. Store in lockers only
- c. Discard in designated barrels - do not take home.

5. VISITOR CONTROL:

- a. All visitors will wear PPE in designated areas.
- b. Supervisor issues visitor PPE
- c. Signs posted designating PPE areas

6. DESIGNATED WORK AREAS:

- a. Bldg. 243B - Manufacturing Section
- b. Bldg. 243C - Foundry bandsaws and Pattern Shop
- c. Bldg. 243ED - Fiberglass sanding rooms
- d. Bldg. 440 - Fiberglass area
- e. Bldg 475F - Fiberglass area

I certify that I have been briefed on the MAN Fiberglass Protection Plan and understand my responsibilities.

(Employee's Signature)

Date _____

(Supervisor's Signature)

Date _____

(This page left blank)

APPENDIX B
SM-ALC Ventilation Systems

(This page left blank)

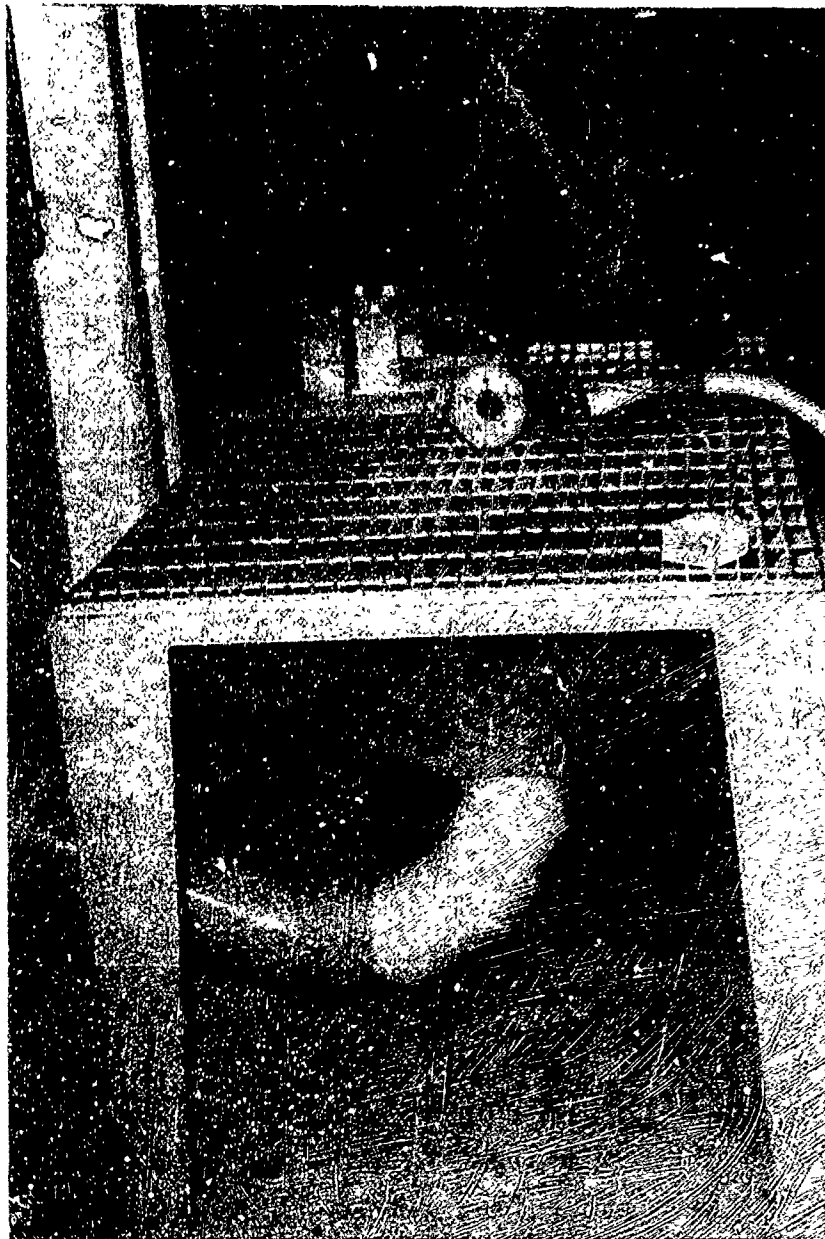

Figure B-1. Downdraft Exhaust Sanding Table with Five Inch Sander with Vacuum Attachment



Figure B-2. Five Inch Sander with Vacuum Attachment. Exhaust Ventilation Holes Built into Sander Face and Sandpaper

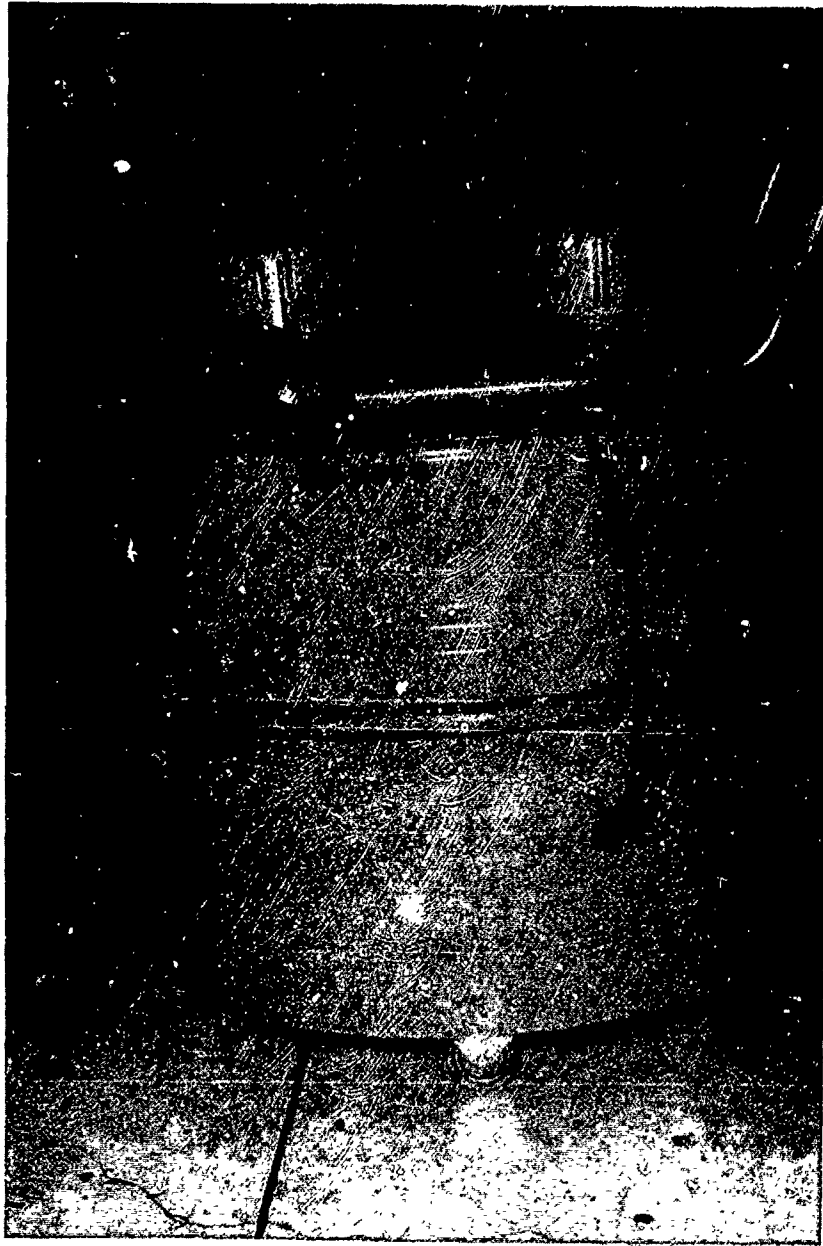

Figure B-3. Portable Vacuum Cleaner with HEPA Final Filter for Use with Sanders

(This page left blank)

APPENDIX C

Composites Repair Equipment List

(This page left blank)

Composites Repair Equipment
Used by SM-ALC/TIMCH-2

Portable vacuum with optional HEPA filter, Nilfisk model GS 82, Nilfisk of America, Inc., 300 Technology Dr., Malvern, PA 19355, (215)647-6420

Five inch orbital sander with built-in vacuum exhaust connections
Dynorbital model 50621, Dynabrade Inc., 72-T E. Niagara St., Tonawanda NY
(716) 694-4600

Ultrasonic knife (for cutting uncured laminated parts): NSN 3449-01-221-3776

Self-healing urethane table top, "Durocast" or "Rightcast" (avoids damaging parts and table top, "Shore A of 85")
Airtech, Carson CA . (213) 603-9683
Technology Marketing Inc. (801) 265-0111

Gloves, natural rubber coated, low-silicon, low dust, cotton gloves.
(Protects hands during wet lay-up without depositing silicon or dust on composite, which can delaminate parts.)
P.N. SF-1285, 144 pair. Available in small, medium, large and extra-large. Western Safety Equipment Co., P.O. box 277, St. Charles MO 63302. (314) 946-6121

Vacuum Transducer Assembly Kit (venturi device to generate 29 inches mercury vacuum by using compressed air)

Manufacturer: Air Vac Engineering, Milford CT. (203) 874-2541

Distributors: Willard Engineering, Hawthorne CA. (213) 679-2500

ATTN: Wayne Cousins

Kit P.N. VTAK-001A includes: vacuum guage,
P-18 muffler, AVR0934 transducer, brass fittings.
\$30.63

James Wilby Co, San Rafael CA. (415) 457-6880

ATTN: Bob Wilby

Kit P.N. AVR-093H-M-VG includes: vacuum guage,
muffler, transducer, brass fittings. \$39.75

(This page left blank)

APPENDIX D
Exhaust Ventilation System Design

(This page left blank)

Proposed Fiberglass Sanding Table Ventilation System
129 CAMS Structural Repair
Hangar 3, Room 120
Moffett Field NAS, CA

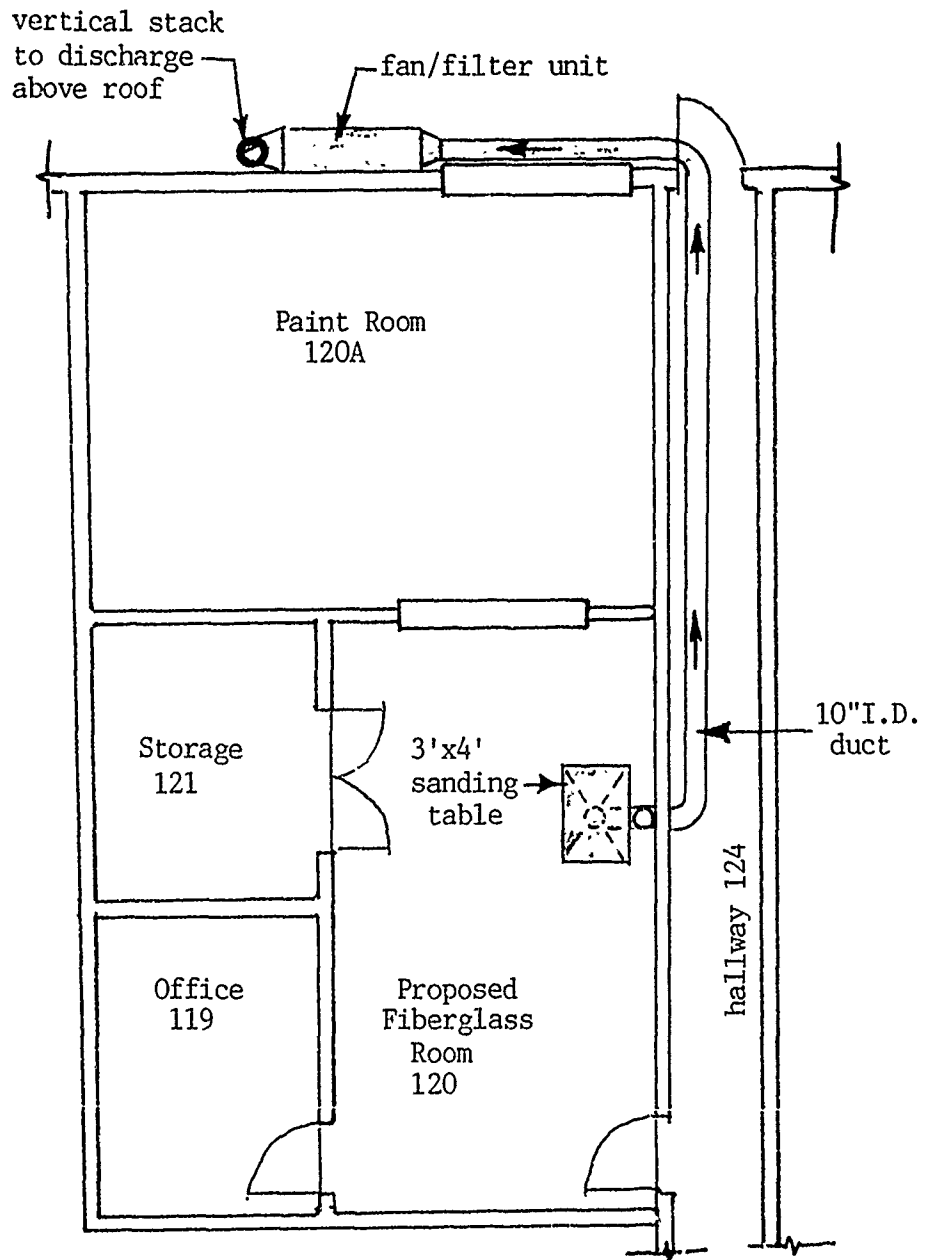

Proposed Fiberglass Sanding Table Design

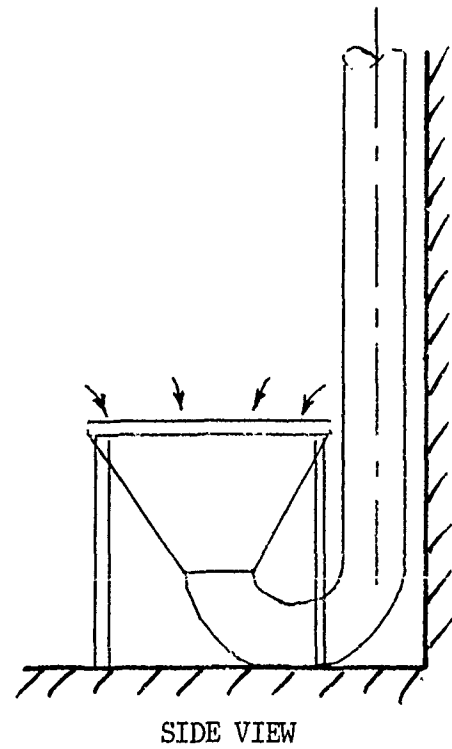
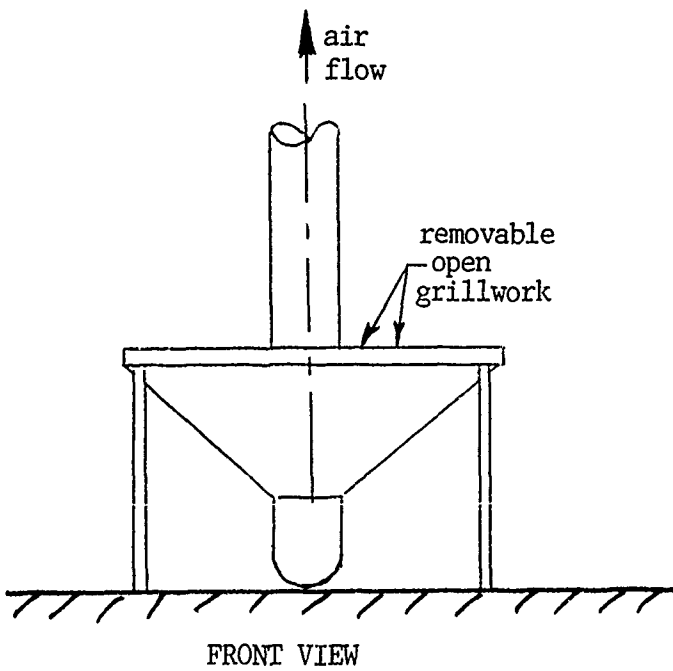
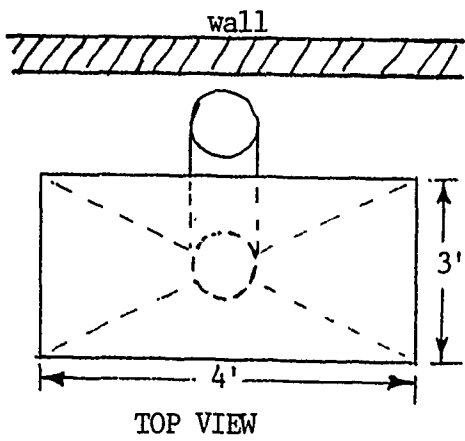

NOT TO SCALE

Ventilation Specifications
Fiberglass Sanding Table, Ductwork and Fan Unit

- Fan Unit
 - 2000 cubic feet per minute (cfm) exhaust flow from sanding table connection
 - less than 70 dBA sound level at exterior and interior building positions 5' above floor level
 - HEPA filtration (capture \geq 99.97% of dioctyl phthalate aerosols with 0.3 μ m median diameter)

- Ductwork
 - Maintain 3500 feet per minute (fpm) velocity in ductwork to minimize dust collection
 - Dust cleanouts in straight ductwork for every 12 feet of horizontal ductwork
 - Tapers to larger or smaller openings less than or equal to 45°
 - Elbow with turning radius greater than or equal to 1.5 times duct diameter

- Acceptance Testing (written copy of measurements must be provided)
 - Air flow rate measured by 10 point traverse with pitot tube at two access holes 90° apart and \geq 7 duct diameters along straight pipe downstream from sanding table (see attached diagram for locations). Average velocity \geq 500 fpm. Total flow \geq 2000 cfm.
 - Static pressure measured at one of the two pitot traverse holes, and reported in inches water guage ("wg)
 - Noise levels 5' above the floor in fiberglass room, hallway to fiberglass room, and exterior to Hangar 3 measured with a sound level meter meeting ANSI Standard S1.4 for Type I or Type II sound level meters. Sound level \leq 70 dBA.

ACGIH Velocity Pressure Method Calculation Sheet
Fiberglass Sanding Table

129 CAMS Structural Repair
Hangar 3, Room 120
Moffett Field NAS, CA

	A-B	C-D
1 Duct Segment Identification		
2 Volumetric Flowrate (cfm)	2000.000	2000.000
3 Minimum Transport Velocity (fpm)	3500.000	3500.000
4 Duct Diameter (inches)	10.000	10.000
5 Duct Area (sq.ft.)	0.545	0.545
6 Actual Duct Velocity (fpm)	3666.930	3666.930
7 Duct Velocity Pressure ("wg)	0.838	0.838
8 H Slot Area (sq.ft)	NA	NA
9 O S Slot Velocity (fpm)	NA	NA
10 O L Slot Velocity Pressure ("wg)	NA	NA
11 D O Slot Loss Factor (fig.5-15, chap.10)		
12 T Acceleration Factor (0 or 1)		
13 S S Plenum loss per VP	0.000	0.000
14 U Plenum SP ("wg)	0.000	0.000
15 C Duct Entry Loss Factor (fig.5-15, chap.10)	0.250	0.000
16 T Acceleration Factor (0 or 1)	1.000	0.000
17 I Duct Entry Loss per VP	1.250	0.000
18 O Duct Entry Loss	1.048	0.000
19 N Other Loss ("wg)	0.000	0.000
20 Hood Static Pressure ("wg)	1.048	0.000
21 Straight Duct Length (feet)	46.000	32.000
22 Friction Factor (fig.5-18 or equation below)	0.023	0.023
23 Friction Loss per VP	1.058	0.736
24 No. of 90 degree elbows	5.000	1.000
24a Elbow friction factor (see below)	0.390	0.390
25 Elbow Loss per VP	1.950	0.390
26 No. Entries	0.000	0.000
26a Branch Entry loss factor (see below)	0.000	0.000
27 Entry Loss per VP	0.000	0.000
28 Special Fittings Loss Factors	0.000	0.000
29 Duct Loss per VP	3.008	1.126
30 Duct Loss ("wg)	2.522	0.944
31 Duct SP Loss ("wg)	3.569	0.944
32 Cumulative Static Pressure ("wg)	-3.600	0.940

Fan Static Pressure = $0.94 + 3.60 - 0.84 = 3.7$ "wg

Calculated Straight Duct Friction Factor	Q (cfm)	Diam. (")
0.023	2000.000	10.000

90 Degree Elbow Friction Factors

<u>R/D</u>	<u>Loss Factor</u>
Mitered	1.25
1.5	0.39
2.0	0.27
2.5	0.22

Branch Entry Loss

<u>Angle</u>	<u>Factor</u>
15 deg.	0.090
30 deg.	0.180
45 deg.	0.280
60 deg.	0.440

MODEL F120 SPECIFICATIONS AND TECHNICAL DATA

SPECIFICATIONS

- DIMENSIONS:** 26"H x 25"W x 68"L
- CONSTRUCTION:** 16 ga. welded steel cabinet with side doors, finished with chemical and oil resistant paint.
- WEIGHT:** 260 lbs.
- FILTER ACCESS:** Hinged side access door. Filters hard mounted. No by-pass like track mounted filters.
- AIR FLOW:** 3800 CFM (2000 W/HEPA or V-Bank)
- ELECTRICAL:** 2 HP TEFC ball bearing motor, 1725 RPM, 208/230/460/3/60 Std. 3 HP optional. 115/230/1/60 optional.
- MOTOR CURRENT, TYP.** 460/3 3.1 amps, 2 HP
230/3 6.3 amps, 2 HP
208/3 6.6 amps, 2 HP
- BLOWER:** 12 x 12 forward curved, belt drive with 1" shaft, sealed ball bearings, and adjustable speed pulley. 4-way adjustable grille, Std. Class II optional (For high static).
- NOISE LEVEL:** 80 dBA @ 5 ft. 69 dBA @ 5 ft. with silencer.
- THROW OF AIR:** 65-110 ft.
- PREFILTERS:** 4" pleated Std. 2" aluminum mesh optional. Oil mist baffle optional. 10 ft² polyester RMP optional.
- MAIN FILTERS:** 120 ft² bag, 65% Std.
120 ft² bag, 90/95% optional.
HEPA filter + bag filter optional.
Gas adsorber + bag filter optional.
Easy Clean filter optional.
- OTHER OPTIONS:** Source capture plenum for ducting inlet collars per customer specification.
Pressure gauge indicates filter changes.
Silencer.

PERFORMANCE

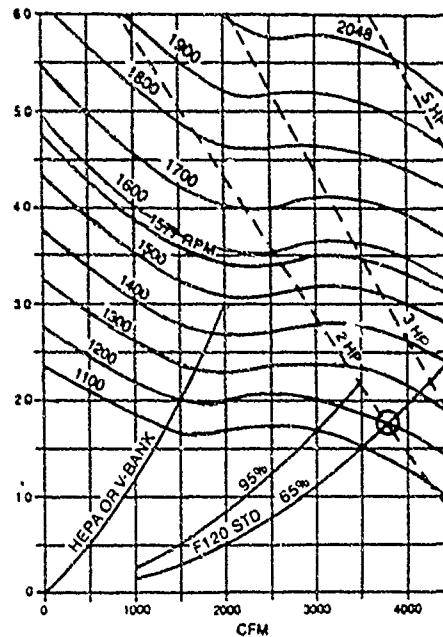

NOTE. CLASS I UP TO 1577 RPM
CLASS II UP TO 2048 RPM

DIMENSIONS

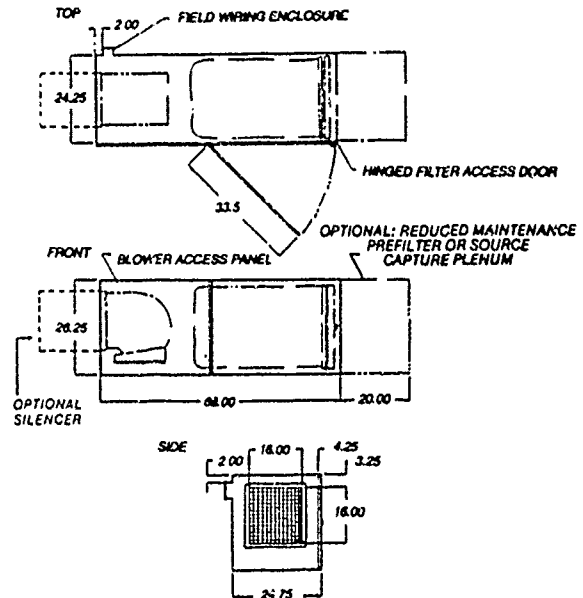

AFS has a policy of continuous research and improvement, and reserves the right to change design and specifications without notice



Airflow Systems, Inc.

P.O. Box 743366, Dallas, TX 75374 (214) 272-3003 FAX (214) 272-7540

AIR EXCHANGE, INC.
1185 San Mateo Ave.
San Bruno, CA 94066
(415) 871-2945

120589

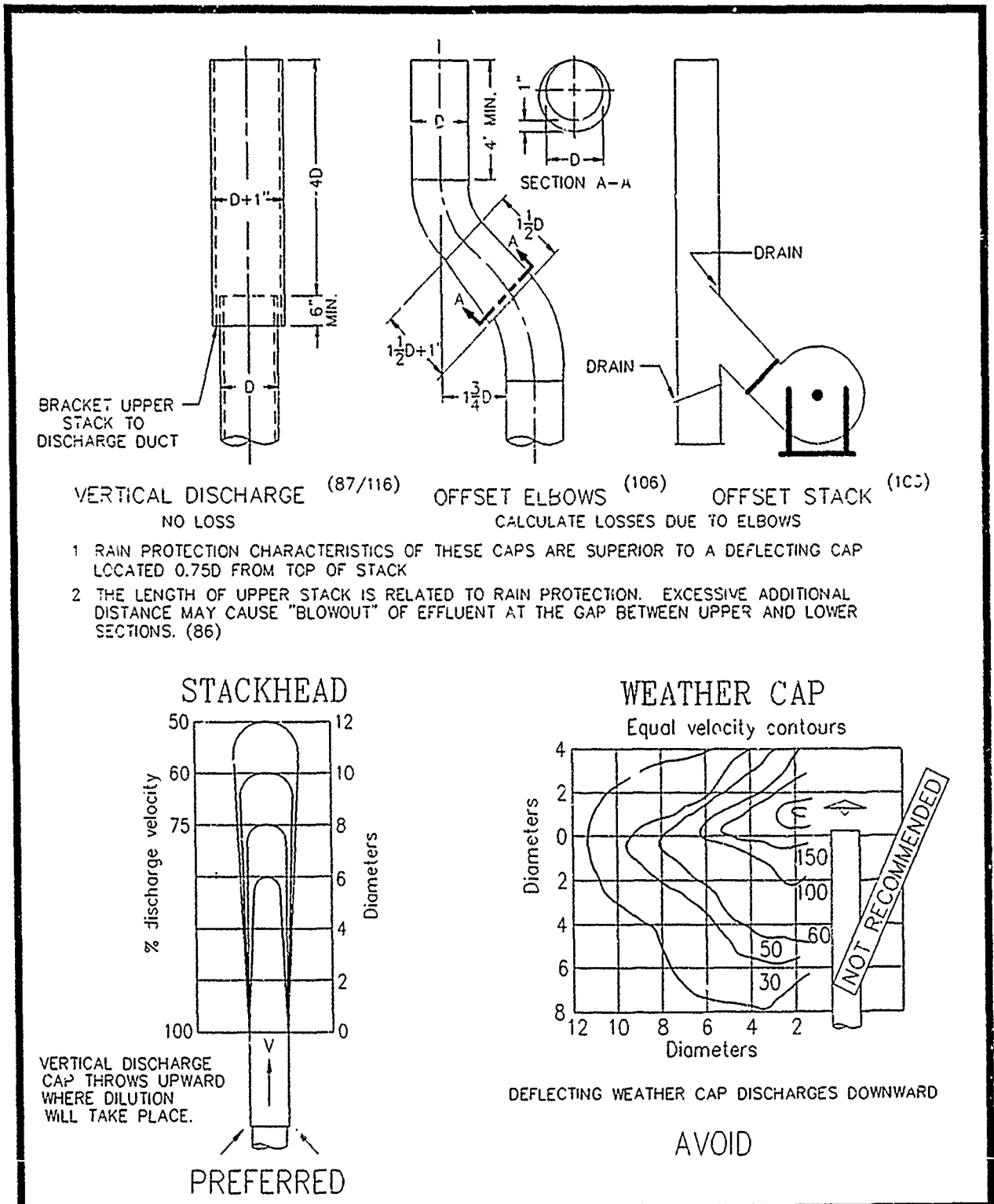

AMERICAN CONFERENCE
OF GOVERNMENTAL
INDUSTRIAL HYGIENISTS

STACKHEAD CONSTRUCTION

DATE 1-88

FIGURE 8-6

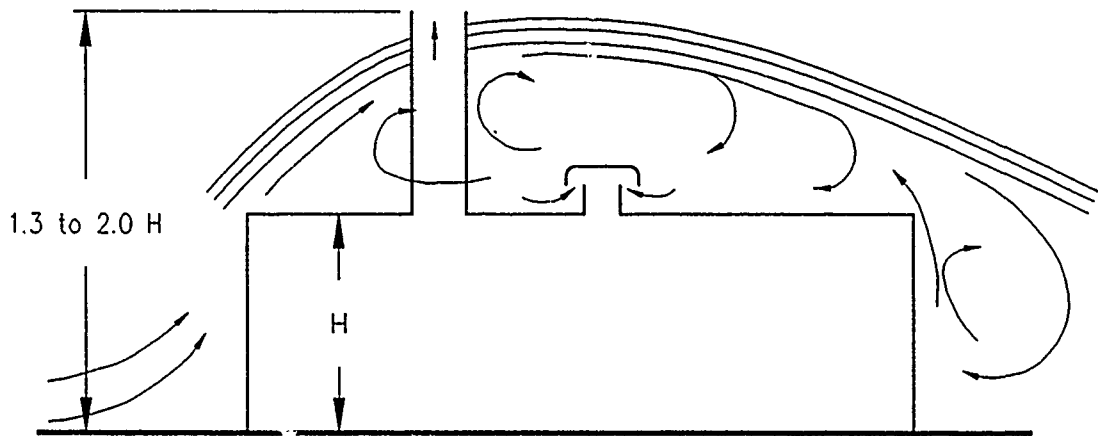

PREFERRED

High discharge stack relative to building height, air inlet on roof.

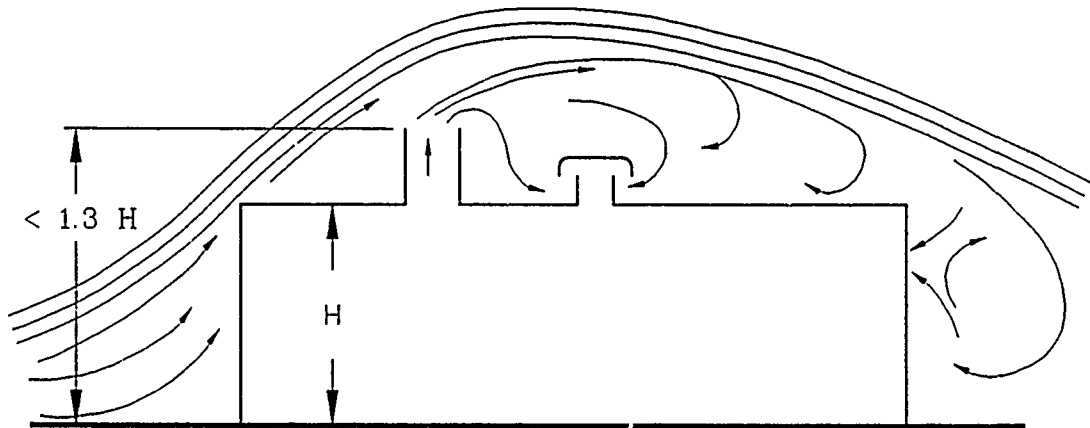

AVOID

Low discharge stack relative to building height and air inlets.

This applies only to the simple case of a low building without surrounding obstructions on reasonably level terrain.

Note: Low pressure on the lee of a building may cause return of contaminants into the building through openings.

(Ref. 5.7)

AMERICAN CONFERENCE OF GOVERNMENTAL INDUSTRIAL HYGIENISTS	<i>STACK HEIGHT</i>	
	DATE 1-88	FIGURE 5-32

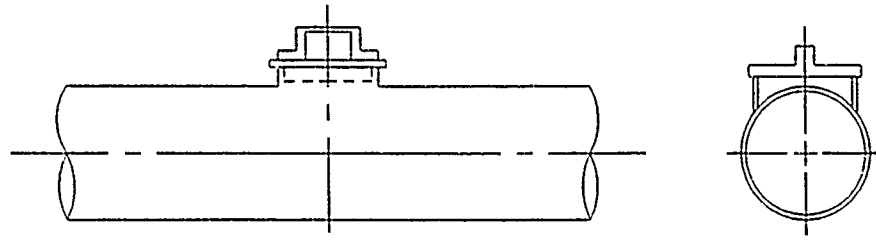

PULLOUT CAP

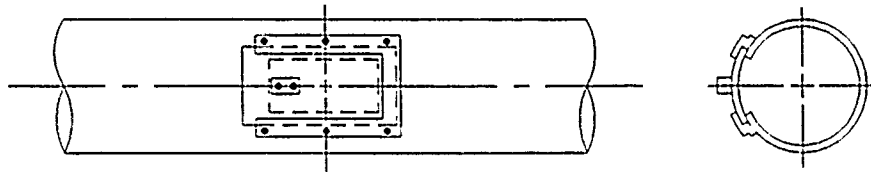

SLIDE

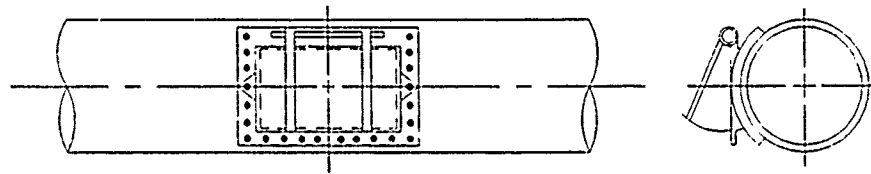

C.I. HINGED DOOR

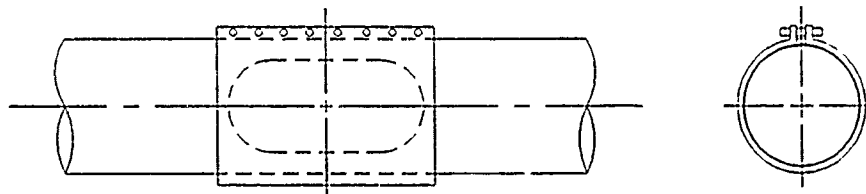

SPLIT SLEEVE
(ALSO FAN CONNECTION)

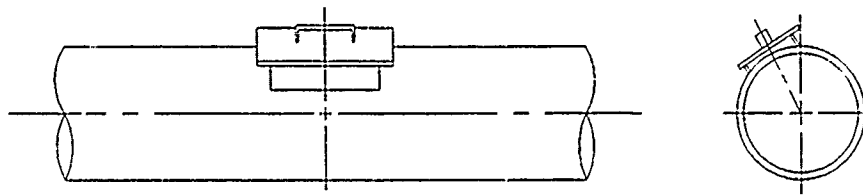

PULLOUT CAP

AMERICAN CONFERENCE
OF GOVERNMENTAL
INDUSTRIAL HYGIENISTS

CLEANOUT OPENINGS

DATE 1-88

FIGURE 8-4

TORIT PORTA-TRUNK™ (PT-1000)

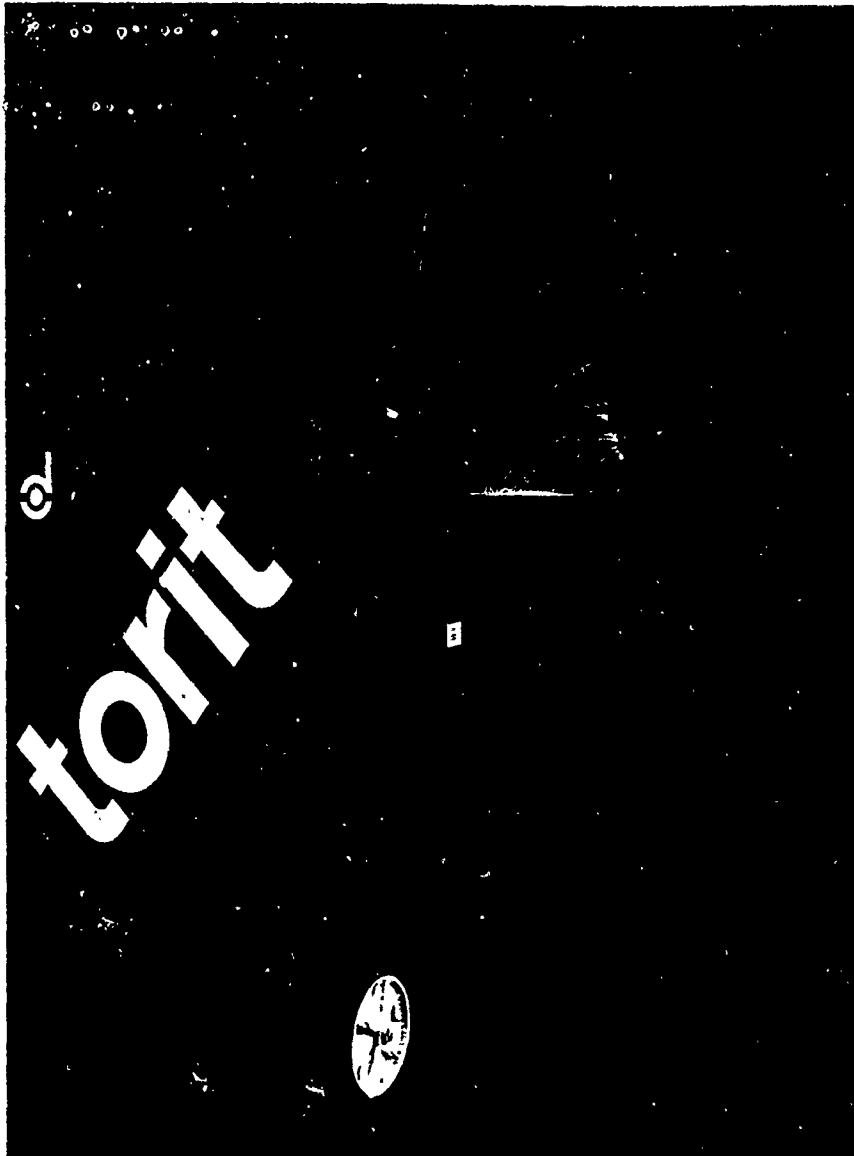

TORIT PORTA-TRUNK (PT-1000). This compact portable collector rolls into action wherever it's needed; just plug it in and it's ready to go. The Porta-Trunk's small footprint makes economical use of your floorspace, yet a powerful 1½ hp motor pulls a hefty 780 cfm through its filter—very quietly. The PT-1000's Flex-Trunk collector arm extends up to seven feet from the unit for precise positioning and the operating control is on the hood within immediate reach

Model	Dimensions	Weight	Power	Compressed Air	Air Volume	Filter Elements
PT1000	35¾"x27½"x40¼" (L x W x H)	340 lbs.	1½ HP (115/60/1)	NONE	ONE FLEX TRUNK:— 780 CFM	1

TORIT FLEX-TRUNK (FT-500).

Torit Flex-Trunk source collection arms facilitate quick collection of fine particles and fumes at the source—before they reach the worker's breathing zone. They're available with or without exhaust fans and can be mounted on the ceiling or walls. They're also used as attachments to the Trunk 2000 and the Porta-Trunk. Flex-Trunks are available with either a 7-ft. or 14-ft. reach. The flexible design of the Flex-Trunk allows for precise positioning to the spot where it will be most effective.



Accessories:

FUME EXHAUST FAN: Provides 970 CFM exhaust flow through 7 ft. and 14 ft. FLEX-TRUNK. Power: 2HP (110/220/60/1); or (208/230/460/575/60/3); or (380/50/3). Available with steel or aluminum fan wheel.

HALOGEN WORK LIGHT: Hood Mount 75W, 12V halogen mini-lamp. Minimizes obstruction of air flow.

MOUNTING BRACKETS: Several mounting bracket configurations are available for FLEX-TRUNK installation to wall, ceiling or bench.

This page left blank

Distribution List

	Copies
129 TAC Hospital/SGPB NAS Moffett Field CA 94035-5006	5
HQ ANGSC/SGB Mail Stop 18 Andrews AFB DC 20331-6008	1
USAF Clinic McClellan/SGB McClellan AFB CA 95652-5300	1
SM-ALC/TIMCH-2 McClellan AFB CA 95652-5000	1
HQ AFLC/SGBE Wright-Patterson AFB OH 45433-5001	1
HQ AFSC/SGPA Andrews AFB DC 20334-5000	1
HQ ATC/SGPB Randolph AFB TX 78150-5001	1
HQ MAC/SGPB Scott AFB IL 62225-5001	1
HQ TAC/SGPB Langley AFB VA 23665-5578	1
HQ SAC/SGPB Offutt AFB NE 68113-5001	1
HQ AFSPACECOM/SGB Peterson AFB CO 80914-5001	1
HQ PACAF/SGPB Hickam AFB HI 96853-5001	1
HQ USAFE/SGPA APO New York 09094-5001	1
HQ AFRES/SGB Robins AFB GA 31098-6001	1
HQ USAF/SGPA Bolling AFB DC 20332-6188	1
7100 CSW Medical Center/SGB APO New York 09220-5300	1

Det 1, AFOEHL APO San Francisco 96274-5000	1
USAFSAM/TSK/ED/EDH/EDZ Brooks AFB TX 78235-5301	1 ea
Defense Technical Information Center (DTIC) Cameron Station Alexandria VA 22304-6145	2
HQ HSD/XA Brooks AFB tx 78235-5000	1