

1a REPORT SECURITY CLASSIFICATION Unclassified		11	
2a SECURITY CLASSIFICATION AUTHORITY		3	
2b DECLASSIFICATION/DOWNGRADING SCHEDULE DTIC SELECTE JAN 30 1991 D		AD-A231 329	
4 PERFORMING ORGANIZATION REPORT NUMBER(S) C-6734-006		5 MONITORING ORGANIZATION REPORT NUMBER(S) USAFSAM-JA-90-68	
6a NAME OF PERFORMING ORGANIZATION QuesTech, Inc.		7a NAME OF MONITORING ORGANIZATION USAF School of Aerospace Medicine (RZP)	
6b ADDRESS (City, State, and ZIP Code) 7600-A Leesburg Pike Falls Church, VA 22043		7b ADDRESS (City, State, and ZIP Code) Human Systems Division (AFSC) Brooks AFB, TX 78235-5301	
8a NAME OF FUNDING/SPONSORING ORGANIZATION		9 PROCUREMENT INSTRUMENT IDENTIFICATION NUMBER F33615-87-D-0650 #006	
8b OFFICE SYMBOL (if applicable)		10 SOURCE OF FUNDING NUMBERS	
8c ADDRESS (City, State, and ZIP Code)		PROGRAM ELEMENT NO 61102F	PROJECT NO 2312
		TASK NO W1	WORK UNIT ACCESSION NO 22
11 TITLE (Include Security Classification) Thermal Control System for the Investigation of Specific Absorption Rates for Specimens Exposed to Electromagnetic Radiation			
12 PERSONAL AUTHOR(S) Smolenski, D M			
13a TYPE OF REPORT Final	13b TIME COVERED FROM 89/9/1 TO 90/8/31	14 DATE OF REPORT (Year, Month, Day)	15 PAGE COUNT
16 SUPPLEMENTARY NOTATION:			
17 COSATI CODES		18 SUBJECT TERMS (Continue on reverse if necessary and identify by block number)	
FIELD 06	GROUP 07	Radiofrequency Radiation Dosimetry,	
20	14	Thermal Control,	
		Specific Absorption Rate	
19 ABSTRACT (Continue on reverse if necessary and identify by block number) A thermal control system was developed to automatically maintain biological and chemical specimens at a controlled thermal profile during exposure to electromagnetic radiation to aid in the investigation of specific absorption rates. Hot and cold air supplies are mixed using mass flow control valves to generate an air source of controlled temperature at a constant mass flow rate. This air source is used to cool or heat the specimen which is within a low thermal-mass holder. By maintaining a constant mass flow rate for the air, the temperature difference between the input and exhaust air will directly indicate the heat energy removed/added to the specimen. A non-radiofrequency field perturbing temperature probe is inserted into the specimen to provide the temperature information to the controller. Using a standard specimen size of 1 ml, the control system has maintained the specimen temperature to within ±0.05°C maximum temperature deviation during electromagnetic radiation exposure.			
20 DISTRIBUTION/AVAILABILITY OF ABSTRACT <input checked="" type="checkbox"/> UNCLASSIFIED/UNLIMITED <input type="checkbox"/> SAME AS RPT <input type="checkbox"/> DTIC USERS		21 ABSTRACT SECURITY CLASSIFICATION Unclassified	
22a NAME OF RESPONSIBLE INDIVIDUAL Johnathan L. Kiel		22b TELEPHONE (Include Area Code) 512/536-3583	22c OFFICE SYMBOL USAFSAM/RZP

**THERMAL CONTROL SYSTEM FOR THE INVESTIGATION OF  
SPECIFIC ABSORPTION RATES FOR SPECIMENS  
EXPOSED TO ELECTROMAGNETIC RADIATION**

D. M. Smolenski

QuesTech, Inc. 7600-A Leesburg Pike, Falls Church, VA 22043

**ABSTRACT**

A thermal control system was developed to automatically maintain biological and chemical specimens at a controlled thermal profile during exposure to electromagnetic radiation to aid in the investigation of specific absorption rates. Hot and cold air supplies are mixed using mass flow control valves to generate an air source of controlled temperature at a constant mass flow rate. This air source is used to cool or heat the specimen which is within a low thermal-mass holder. By maintaining a constant mass flow rate for the air, the temperature difference between the input and exhaust air will directly indicate the heat energy removed/added to the specimen. A non-radiofrequency field perturbing temperature probe is inserted into the specimen to provide the temperature information to the controller. Using a standard specimen size of 1 ml, the control system has maintained the specimen temperature to within  $\pm 0.05$  °C maximum temperature deviation during electromagnetic radiation exposure.

1



Accession For	
NTIS	CRAM
DTIC	TAG
U.S. Dept. of	
Justice	
By	
David [unclear]	
Approved	
Dist	AVAILABILITY STATEMENT
A-1	Specimen

## INTRODUCTION

Throughout the world, the increased use of radiofrequency (RF) devices has caused concern about the exposure guidelines and safety standards. An essential element of the research in biological effects of radiofrequency radiation is dosimetry -- the determination of energy absorbed by an object exposed to the electromagnetic fields.<sup>1</sup> The energy absorbed by an object is directly related to the electromagnetic fields inside the object, not incident upon the object. Since the internal electromagnetic fields will be affected by several factors which are object dependent; i.e., electrical properties, size, shape, and orientation; the determination of the internal electromagnetic fields by measurement of the external incident fields is not possible. Instead, dosimetry is used to relate both the internal fields and the effects caused when they interact directly with the biological and chemical specimens to the incident fields.

The Radiation Physics Branch of the Radiation Sciences Division at the United States Air Force School of Aerospace Medicine (USAFSAM) is involved in the investigation of specific absorption rates (SARs) for biological and chemical specimens exposed to electromagnetic radiation (EMR). The term "SAR" is a dosimetric unit which indicates the amount of energy absorbed per unit time for a given volume or mass of specimen, e.g., watts per kilogram. Average whole-body SARs obtained using techniques such as Twin-well and Dewar flask calorimetry are invaluable when quantifying power absorption characteristics. Many experiments, however, require localized SAR information on the specimen (e.g., research on partial-body resonances require information from numerous point SARs throughout the entire specimen), while maintaining thermal equilibrium. Other experiments

are concerned with controlling the rate of temperature increase of a specimen exposed to EMR, and/or mimicking the temperature profile of an EMR heated specimen with a control specimen not exposed to EMR.

Temperature regulated water baths have historically been used to maintain a specimen at thermal equilibrium. However, the water used to maintain the specimen temperature is also absorbing the EMR at a rate dependent on its own characteristics (i.e., temperature and number of impurities). The large specific heat of water also causes significant lag-times in the responsiveness of the system to temperature changes. For this reason, air is used to maintain thermal equilibrium of the specimen.<sup>2</sup> The thermal control system was developed since there was no device commercially available to perform the precision temperature control required on a specimen in an electromagnetic field. This article describes the thermal control system that was developed under contract to the Air Force. Comparison of the results between the automated system and the predecessor manual system will be discussed.

## **I. SYSTEM DESCRIPTION AND SIMULATION**

A block diagram of the thermal control system is shown in Figure 1. A laboratory compressed air supply is split into two paths. One air path is heated and the other air path is cooled by passing the air tubes through water baths. The rate of air flow in each path is controlled by in-line control valves. The two air flows are mixed to obtain a single air flow which is directed over the sample holder to regulate the temperature of the specimen. A non-RF field perturbing temperature probe is connected to the controller to monitor the specimen. As the specimen

temperature changes in response to the forced air convection and RF induced heating, the controller adjusts the air flow mixture to compensate.

#### A. Theoretical basis

In developing the specimen thermal control system, we found it useful to understand the heat transfer system and its basis in thermodynamics and heat transfer.<sup>3</sup> The field of thermodynamics deals with systems in equilibrium; where equilibrium is defined as the condition when the energy added is equal to the energy stored plus the energy removed. The principles of thermodynamics can be used to predict the amount of energy required to change a system from one equilibrium state to another. They may not be used to predict how fast a change will take place, since the system is not in equilibrium during those changes. The applied science of heat transfer supplements the first and second principles of thermodynamics by providing additional experimental rules which may be used to establish energy transfer rates.

Since the objective of the thermal control system is to maintain a specimen in thermal equilibrium, it must be able to offset any externally applied energy (EMR, ultrasonic, infrared, etc.) by changing the rate at which energy is removed from the specimen. During an experiment, four energy transfer mechanisms affect the specimen temperature: absorption of RF energy, radiation, conduction, and convection. The design of the equipment ensures that the energy transfer due to radiation and conduction is small compared to absorption and convection. For this reason, radiation and conduction were assumed negligible in the development of the heat transfer equation. The change in temperature of the specimen

during a time interval,  $\Delta t$ , can be predicted using Equation 1.

$$T_s(t+\Delta t) - T_s(t) = \frac{Q_{abs}\Delta t}{m_s c_p} - \frac{hA\Delta t}{m_s c_p} [T_s(t) - T_a(t)] \quad (1)$$

where:  $T_s(t+\Delta t)$  is the sample temperature at time  $(t+\Delta t)$ .

$T_s(t)$  is the current sample temperature.

$Q_{abs}$  is the rate of heat energy transfer due to absorption of RF energy.

$m_s$  is the mass of the specimen.

$c_p$  is the specific heat of the specimen.

$h$  is the average convective heat transfer coefficient.

$A$  is the surface area of the specimen.

$T_a(t)$  is the current free stream temperature of the air.

The first term relates the rate of RF energy absorbed by the specimen,  $Q_{abs}$ , to the change in specimen temperature. The second term which, is Newton's Law of Cooling, accounts for the change in the specimen temperature due to forced convection.

In the control system,  $T_s$  must be maintained at some reference temperature,  $T_{ref}$ , regardless of external factors. The form of the controlling equation is driven by the following considerations. First, the equation must provide zero corrections if the specimen temperature is equal to the reference temperature, a positive correction when the specimen temperature is less than the reference, and a negative correction when the specimen temperature is greater than the reference. Second, to provide a faster system response and eliminate excessive overshoot and undershoot the

equation must contain a predictive correction factor which is based on the rate of change of the specimen temperature. Furthermore, this correction factor should have an inverse effect on the control equation which is proportional to the slope of the specimen temperature curve. In other words, a large  $T_s$  slope should reduce the  $\Delta T_a$  corrections more than a small slope, and a slope of 0 requires no correction effect on  $\Delta T_a$ . To simplify the control equation we required a constant air mass flow rate over the specimen. The use of a constant air mass flow was done to maintain a constant  $h$  as seen in Equation 1. If both the mass flow rate and temperature of the air across the specimen varies, a nonlinear variation in the heat transfer coefficient occurs, which results in poor temperature prediction. In addition, the use of a constant mass flow rate air supply of variable temperature allows the researcher to easily verify calculated average SAR values by multiplying the input and outlet air temperature difference by the mass flow rate and the specific heat of air to determine the energy absorbed by the specimen. The final form of the control equation is shown in Equation 2:

$$\Delta T_a = C_1 \times (T_{ref} - T_s(t + \Delta t)) - C_2 \times \frac{(T_{ref} - T_s(t + \Delta t)) - (T_{ref} - T_s(t))}{\Delta t} \quad (2)$$

where:  $\Delta T_a$  is the change in air temperature over  $\Delta t$ .

$C_1$  &  $C_2$  are positive constant multipliers.

$T_{ref}$  is the desired reference temperature.

Equation 2 satisfies the boundary conditions and includes one slight modification to provide a more robust controlling equation of a general form. In the second term, incorporating the change in specimen

temperature with respect to a reference temperature, rather than 0, allows the thermal control system to track and follow a nonconstant  $T_{ref}$ . This is the case if a specific specimen heating rate is desired, or if a previously recorded temperature profile must be followed by the specimen.

## B. Computer simulation

Before the hardware and control software were designed, a computer simulation of the specimen temperature control problem was developed to obtain a better understanding of the process and control algorithm. One important point learned from the simulation was that oversampling the specimen temperature results in performance as poor as undersampling. Oversampling causes multiple air temperature corrections to be made before the effects of the first correction have been detected by the temperature probe causing violent swings in the control air temperature. The specimen temperature continuously oscillates about the desired temperature as the control system overcompensates for the temperature difference.

## II. HARDWARE DESCRIPTION

The system controller provides the data storage, graphical display, and computational abilities for the thermal control system. The controller is an 80286 based, MSDOS system with hard disk storage, math coprocessor, VGA display, and a data acquisition board. The minimum operating requirements were determined from the specifications for the thermal control system and the interface requirements for the Vitek, Model 101, Electrothermia Monitors used to interface the nonperturbing



temperature probes. The analog output signal from the Vitek Electrothermia Monitors is 10 mV per degree Celsius. The thermal control system is required to control the temperature to 0.1 °C or better. To allow adequate resolution, the thermal control system must detect changes approximately ten times the required control resolution, or 0.01 °C. This detection resolution translates into a minimum detectable voltage change of 0.0001 volts, or a minimum resolution of 0.1 mV/LSB (least significant bit). In addition, the analog-to-digital (A/D) converter must input a signal of 0.5 volts while maintaining the 0.1 mV/LSB resolution. To provide the control signal to the flow control valves, 2 digital-to-analog (D/A) converter channels were required to supply the 0-5 VDC signal. Differential inputs to the A/D converters were desirable to reduce common-mode noise which may be induced on the input lines due to the proximity of the RF power sources and high resistance input.

The Equipment Module is connected to the controller/data acquisition board through the 50-conductor ribbon cable. The Equipment Module contains the power supply, thermistor interface, and flow control valves. The controller provides a voltage output based on the sample temperature deviation from the reference temperature and the rate of change of the temperature deviation. Several different types of air control valves are available on the market, i.e., motor operated, thermal expansion, piezo-electric, and electromagnetic. These valves were investigated to determine the optimum control valve. The flow control valves selected for this project are actually mass flow controllers. The mass flow controllers contain an integrated mass flow meter and closed loop control circuitry to maintain a given mass flow rate independent of supply

line pressure fluctuations. Use of an integrated mass flow controller eases the computational requirements of the system controller, and eliminates the requirement for separate mass flow meters to monitor and maintain the mass flow rate at a constant value.

Two air flow temperature sensors are incorporated in the thermal control system. The air flow temperature sensors are placed in the hot and cold air lines immediately before the two air sources are mixed. The controller uses the hot and cold source air temperature information to determine the proportions of hot and cold air to mix for a desired mixed air temperature to blow across the specimen. The air flow temperature sensors contain a glass-bead thermistor to sense the air temperature. A standard bridge circuit with operational amplifiers is used to linearize the temperature response from the thermistors and interface the thermistors with the data acquisition board in the controller.

### III. SOFTWARE DESCRIPTION

The operating software is menu driven to provide ease of use and minimize the time required to learn to operate the system. ASYST software was chosen as the development environment for the thermal control system. The primary reasons for this selection were the programmability of the language and the large number of pre-written routines which were used to perform many of the required functions (i.e., writing to a file, graphing to the display, and performing mathematical manipulations). The ASYST software also interfaces to several data acquisition devices which allows a large field of devices on which to base the data acquisition selection.

The basic software structure is shown in Figure 2. The three

primary operating modes for the controller are: Automatic, Manual, and Capture. Other functions, Plot & View, Print, and File, are provided to assist the user with data analysis and file maintenance after data files have been collected.

#### IV. DISCUSSION

The unit is currently being used to investigate the nonthermal effects of biological specimens due to EMR. Since the thermal control system has the ability to maintain a specimen at a given temperature with very close tolerances, the thermal effects due to EMR exposure have been eliminated. In addition, the ability of the system to provide a constant rate of heating for a specimen, whether exposed to EMR or not, is providing the researchers with information which was not previously measurable concerning the sensitivity of specimens to various heating rates. The system allows the researchers to study the differences between specimens exposed to EMR and those heated using only air. The system also provides the researcher the ability to duplicate a previously recorded specimen temperature profile.

The previous manual technique required an operator to adjust the mixture of the hot and cold air supplies to maintain the specimen temperature. This technique was extremely labor intensive and had several limitations. Perhaps the most severe limitation was the length of time a test could be run. The human operators could concentrate on the task of controlling the sample temperature for test durations of up to 30 minutes. Longer test periods were not possible without undue strain on the operator. The human operators were accurate to within  $\pm 0.2$  °C and were unable to

eliminate the temperature overshoot which was caused by turning on the RF power after the specimen temperature was stabilized. The automated thermal control system can operate for hours unattended while maintaining a temperature variation no greater than  $\pm 0.05$  °C.

#### **ACKNOWLEDGEMENT**

I wish to express my thanks to D. N. Erwin and J. L. Kiel for initiating and supporting this design effort. The work outlined in this article was performed under contract F33615-87-D-0650, D.O. 006, Brooks AFB, Texas.

FIGURE 1 BLOCK DIAGRAM OF AUTOMATED THERMAL CONTROL SYSTEM

FIGURE 2 SOFTWARE STRUCTURE DIAGRAM

1. C. H. Durney, H. Massoudi, M. F. Iskander, Radiofrequency Radiation Dosimetry Handbook (Fourth Edition), (U.S. Air Force School of Aerospace Medicine Technical Report No. 85-73, Brooks AFB, Texas, 1986).
2. J. L. Kiel, D. N. Erwin, D. M. Simmons, Air Force Invention 17,396, Flow Through Cell Cultivation System, Patent Pending.
3. J. P. Holman, Heat Transfer (McGraw-Hill, New York, 1963).

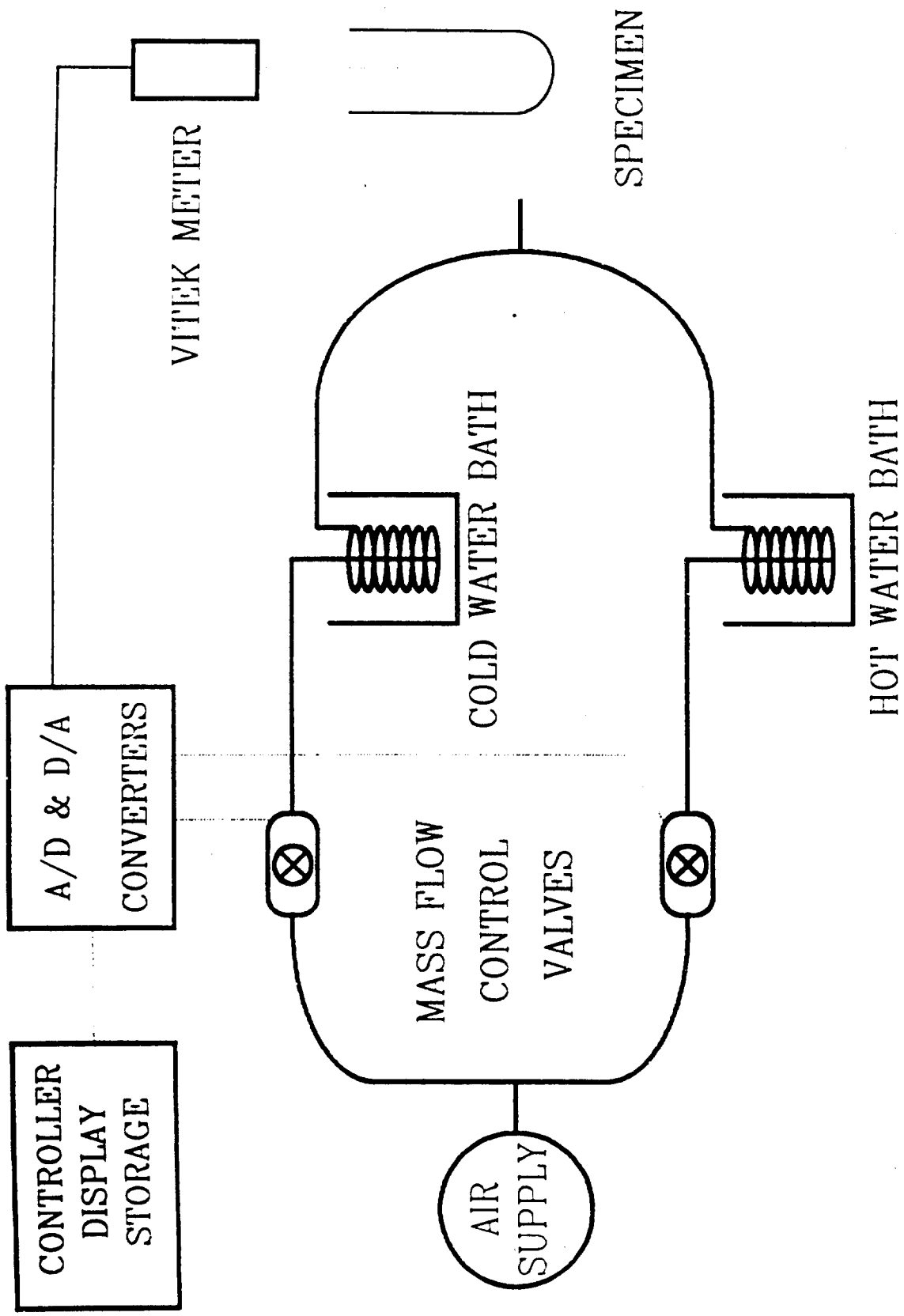

MAIN MENU

AUTO

DATA ACQUISITION / PROBE SET-UP  
AUTOMATIC SAMPLE TEMPERATURE CONTROL  
INPUT FILENAME  
INPUT COMMENTS  
DATA PLOT QUERY  
GRAPHICS DISPLAY

MANUAL

DATA ACQUISITION / PROBE SET-UP  
MANUAL SAMPLE TEMPERATURE CONTROL  
INPUT FILENAME  
INPUT COMMENTS  
DATA PLOT QUERY  
GRAPHICS DISPLAY

CAPTURE

DATA ACQUISITION / PROBE SET-UP  
DATA ACQUISITION PERIOD  
INPUT FILENAME  
INPUT COMMENTS  
DATA PLOT QUERY  
GRAPHICS DISPLAY

VIEW & PLOT

INPUT FILENAME  
VIEW QUERY MENU  
VIEW GRAPHICS DISPLAY

PRINT

INPUT FILENAME

FILE

CHANGE DIRECTORY  
CREATE & CHANGE DIR  
LIST FILES  
COPY FILE  
RENAME FILE  
DELETE FILE

QUIT

EXIT TO DOS