

AD-A230 891

DOCUMENTATION PAGE

Form Approved
OMB No. 0704-0188Public
copy
this

It is estimated to average 1 hour per response, including the time for reviewing instructions, searching existing data sources, gathering and reviewing the collection of information. Send comments regarding this burden estimate or any other aspect of reducing this burden, to Washington Headquarters Services, Directorate for Information Operations and Reports, 1215 Jefferson Davis Highway, Suite 1204, Arlington, VA 22202-4302, and to the Office of Management and Budget, Paperwork Reduction Project (0704-0188), Washington, DC 20503.

1. Agency Use Only (Leave blank).		2. Report Date. Jul 25-27, 1989		3. Report Type and Dates Covered.	
4. Title and Subtitle. Ocean Feature Recognition Using Genetic Algorithms with Fuzzy Fitness Functions (GA/F3)				5. Funding Numbers. Program Element No. 62435N Project No. Task No. 3587 Accession No. DN256010	
6. Author(s). Akenbrandt, C.A.*, B.P. Buckley*, F.E. Petry*, and M. Lybanon				8. Performing Organization Report Number. PR 90:047:321	
7. Performing Organization Name(s) and Address(es). Naval Ocean Research and Development Activity Stennis Space Center, MS 39529-5004				9. Sponsoring/Monitoring Agency Name(s) and Address(es). Naval Ocean Research and Development Activity Stennis Space Center, MS 39529-5004	
11. Supplementary Notes. *Department of Computer Science, Center for Intelligent and Knowledge-based Systems 301 Stanley Thomas Hall, Tulane University, New Orleans, LA 70118 (504)365-5840					
12a. Distribution/Availability Statement. Approved for public release; distribution is unlimited.				12b. Distribution Code.	
13. Abstract (Maximum 200 words). A model for genetic algorithms with semantic nets is derived for which the relationships between concepts is depicted as a semantic net. An organism represents the manner in which objects in a scene are attached to concepts in the net. Predicates between object pairs are continuous valued truth functions in the form of an inverse exponential function ($e^{-\beta/x}$). 1:n relationships are combined via the fuzzy OR (Max [...]). Finally, predicates between pairs of concepts are resolved by taking the average of the combined predicate values of the objects attached to the concept at the tail of the arc representing the predicate in the semantic net. The method is illustrated by applying it to the identification of oceanic features in the North Atlantic.					
14. Subject Terms. (U) genetic algorithms, (U) feature labeling; (U) semantic nets; (U) fitness functions				15. Number of Pages. 7	
				16. Price Code.	
17. Security Classification of Report. U		18. Security Classification of This Page. U		19. Security Classification of Abstract. U	
				20. Limitation of Abstract. SAR	

SECRET
DTIC ELECTE
JAN 31 1991

OCEAN FEATURE RECOGNITION USING GENETIC ALGORITHMS WITH FUZZY FITNESS FUNCTIONS (GA/F³)*

by
C.A. Ankenbrandt¹, B.P. Buckles¹, F.E. Petry¹, & M. Lybanon²

¹Department of Computer Science
Center for Intelligent and Knowledge-based Systems
301 Stanley Thomas Hall, Tulane University
New Orleans, LA 70118, (504) 865-5840

²Remote Sensing Branch
Naval Ocean Research and Development Activity
NSTL Station, MS 39529

Accession For	
NTIS GRA&I	<input checked="" type="checkbox"/>
DTIC TAB	<input type="checkbox"/>
Unannounced	<input type="checkbox"/>
Justification	
By _____	
Distribution/	
Availability Codes	
Dist	Avail and/or Special
A-1	

ABSTRACT

A model for genetic algorithms with semantic nets is derived for which the relationships between concepts is depicted as a semantic net. An organism represents the manner in which objects in a scene are attached to concepts in the net. Predicates between object pairs are continuous valued truth functions in the form of an inverse exponential function ($e^{-\beta|x|}$). In relationships are combined via the fuzzy OR (Max [...]). Finally, predicates between pairs of concepts are resolved by taking the average of the combined predicate values of the objects attached to the concept at the tail of the arc representing the predicate in the semantic net. The method is illustrated by applying it to the identification of oceanic features in the North Atlantic.

keywords: genetic algorithms, feature labelling, semantic nets, fitness functions

* This work was supported in part by a grant from Naval Ocean Research and Development Activity, Grant #N00014-89-J-6003

BACKGROUND

Genetic algorithms are a problem solving method requiring domain-specific knowledge that is often heuristic. Candidate solutions are represented as organisms. Organisms are grouped into populations known as generations and are combined in pairs to produce subsequent generations. An individual organism's potential as a solution is determined by a fitness function.

Fitness functions map organisms into real numbers and are used to determine which organisms will be used (and how frequently) to produce offspring for the succeeding generation. Fitness functions often require heuristic information because a precise measure of the suitability of a given organism (i.e., solution) is not always attainable. An example is the recognition (i.e., labeling) of segments in a scene. General characteristics of objects in the scene such as curvature, size, length, and relationship to each other may be known only within broad tolerance levels. That is, there is great variability in the relationships among objects in different scenes.

Semantic nets (SNs) are effective representations of binary relationships between concepts (e.g., objects in a scene). SNs denote concepts via nodes in a directed graph. The arcs are labelled

by predicates. We introduce here a representation of an organism whose fitness function evaluation is dependent upon an SN context.

Because relationships (i.e., predicates) relating concepts are not precise, their evaluation is in the form of a truth functional with range [0,1] rather than the traditional (0,1). That is, we use fuzzy logic [YA75, ZARA, ZH85] to combine heuristically the information concerning a particular organism. Thus, we derive genetic algorithms with fuzzy fitness functions (GA/F³).

GENETIC ALGORITHMS

Genetic algorithms (GAs) are search procedures modelled after the mechanics of natural selection. They differ from traditional search techniques in several ways. First, GAs have the property of implicit parallelism, where the algorithm is equivalent to a search of the hyperplanes of the search space, without directly testing hyperplane values [H075, G088]. Nearly optimal results have been found by examining as few as one point for every 2^{35} points in the search space [G086]. Second, GAs are randomized algorithms, using operations with nondeterministic results. The results for an operation depend on the value of a random number. Third, GAs operate on many solutions simultaneously, gathering information from all current points to direct the search. This factor mitigates the problems of local maxima and noise.

From a mechanistic view, genetic algorithms are a variation of the generate and test method. In pure generate and test, solutions are generated and sent to an evaluator. The evaluator reports whether the solution posed is optimal. In genetic algorithms, this generate and test process is repeated iteratively over a set of solutions. The evaluator returns information to guide the selection of new solutions for following iterations.

GA terminology is taken from genetics. Each candidate solution examined is termed an organism, traditionally represented as a list. The set of organisms maintained is termed a population, and the population at a given time is termed a generation. Each iteration involves three steps.

First, each organism in the current generation is evaluated, producing a numerical fitness function result. The criteria for evaluation is domain specific information about the relative merit of that particular organism. Better organisms are assigned higher fitness function values. Second, some organisms are selected to form one or more organisms for the next generation. Specifically, the number of copies of each organism selected is directly proportional to its fitness function. Third, some of those organisms selected are modified via genetic operators. Each genetic operator takes the chosen organism(s), and produces a new organism(s). The most common genetic operators include crossover and mutation. This iterative procedure terminates when the population converges to a solution.

The crossover operator takes two organisms selected and combines partial solutions of each. When organisms are represented with lists, single point crossover can be viewed as combining the left hand side of one organism chosen with the right hand side of the other, and conversely. This creates two offspring. The crossover point, that point where the crossover takes place, is randomly determined.

The mutation operator uses a minimal change strategy. It takes a selected organism, and changes the value at one randomly determined position. This corresponds to a tight local search. The offspring produced is identical to the parent except at the mutation point.

GENETIC ALGORITHM PROBLEM MODEL FOR OCEANIC FEATURE LABELING

Scene recognition is an application for which the GA model we propose is suited. For example, Fig. 1(a) is a segmented image of the North Atlantic for which Fig. 1(b) is the original image. The lines (referred to here as segments, s_1, s_2, \dots) represent boundaries between warm and cold regions of sea water. The problem is to classify the segments as Gulf Stream North Wall (NW), Gulf Stream South Wall (SW), cold eddies (CE), warm eddies (WE), continental shelf (CS), and "other" (O).

Relationships which can be expressed as fuzzy truth functions are known to exist within or between classifications. Principal among these are (1) the average width of the Gulf Stream is 50 kilometers, (2) the average diameter of an eddy is 100 kilometers, (3) cold eddies are usually south of the Gulf Stream, and (4) warm eddies are usually north of the Gulf Stream. To these one must add the trivial (yet necessary) relationships such as the south wall is at a lower latitude than the north wall and the known geophysical coordinates of continental shelves.

A scene consisting of classification categories ($cat_1, cat_2, \dots, cat_n$) and relationships expressed as truth functions ($P_{ij}^{(1)}, P_{ij}^{(2)}, \dots$) between categories can be modelled as a semantic net (or, more precisely, an association list). A generic one is shown in Fig. 2. Segments are

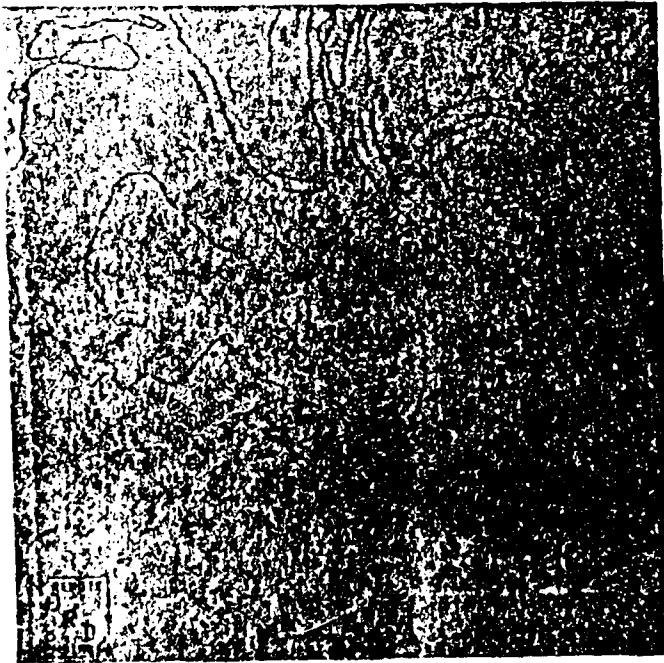

a. Segmented Image



b. Original Infrared Image

Figure 1. Oceanic Features (North Atlantic)

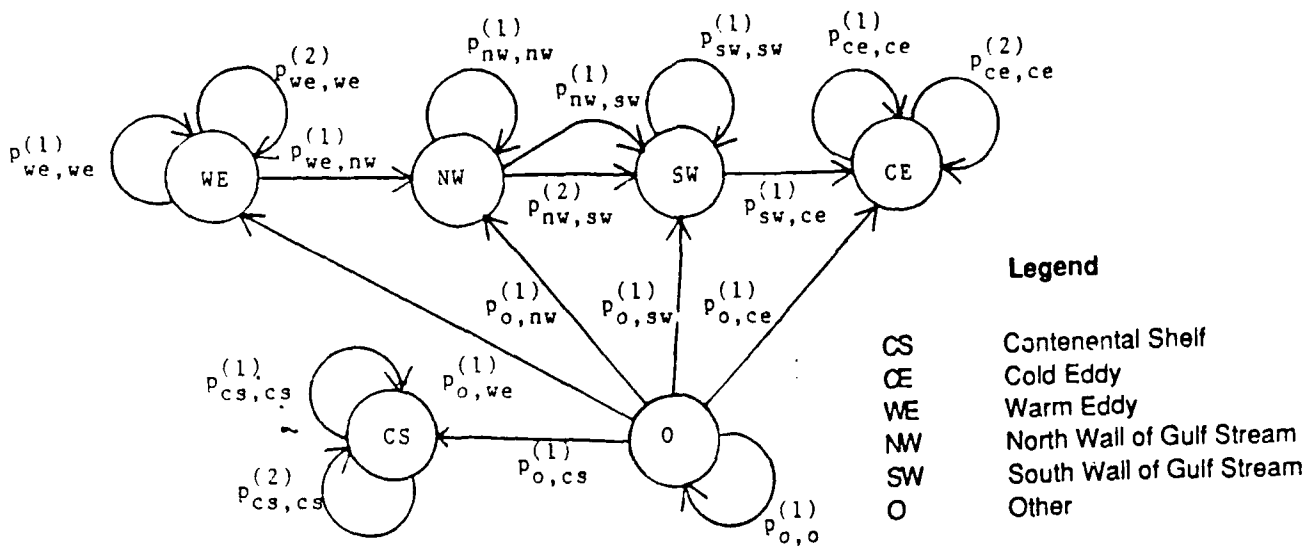

Figure 2. Generic Semantic Net for Oceanic Features

attached to the categories via the INST (instance) relation. An allele (or gene) is a category name. An organism is a list of categories, one allele for each segment. For example, given six segments then (NW, NW, SW, CS, CE, O) and (CE, SW, CE, O, O, CS) are representative organisms. Formally, let an association list be defined as $A = \langle V, P \rangle$ where $V = \{cat_1, cat_2, \dots, cat_m\}$ is a set of categories, and $P = \{P_{ij}^{(g)} \mid i, j \leq m, g = 1, 2, \dots, r_{ij}\}$ is a set of binary predicates. These predicates describe the relationships between categories and the ideal relationship between segments assigned to these categories. Let an organism for spatial labeling be defined as $Q = \langle S, INST \rangle$, where $S = \{s_1, s_2, \dots, s_n\}$ is a set of segments, and $INST: S \rightarrow V$ is a function.

Crossover Operators

There are three applicable crossover operators. These include single point crossover, two point crossover, and varying multiple point crossover [BO87]. Crossover operators require the imposition of a total order on the segments in S. Let $s_i < s_j$ if $i < j$; $s_i = s_j$ if $i = j$; $s_i > s_j$ if $i > j$. Denote by $INST_{O_1}$ the instance mapping for organism O_1 . Single Point Crossover. Given $\langle s_1, s_2, \dots, s_n \rangle$, choose a random integer $k, 1 \leq k < n$. For parent organisms O_1 and O_2 create an offspring, O' , such that

$$INST_{O'}(s_i) = \begin{cases} INST_{O_1}(s_i) & \text{if } i \leq k \\ INST_{O_2}(s_i) & \text{if } i > k \end{cases}$$

Two Point Crossover. Let $\langle s_1, s_2, \dots, s_n \rangle$ be a circular list. Formally, $succ(s_i) = s_{i+1}$ ($pred(s_{i+1}) = s_i$) if $i < n$ and $succ(s_n) = s_1$ ($pred(s_1) = s_n$). Choose two random integers, k_1 and k_2 . For parent organisms O_1 and O_2 create an offspring, O' such that

$$INST_{O'}(s_i) = \begin{cases} INST_{O_1}(s_i) & \text{if } s_i \in \{s_{k_1}, succ(s_{k_1}), \\ \dots, pred(s_{k_2})\} \\ INST_{O_2}(s_i) & \text{otherwise} \end{cases}$$

Varying Multiple Point Crossover. For parent organisms O_1 and O_2 , create an offspring O' such that

$$INST_{O'}(s_i) = \begin{cases} INST_{O_1}(s_i) & \text{with probability 0.5} \\ INST_{O_2}(s_i) & \text{with probability 0.5} \end{cases}$$

Mutation Operator

Our mutation operator selects one segment randomly and assigns it to a randomly determined category. Choose two random integers $k_1, 1 \leq k_1 \leq n$, and $k_2, 1 \leq k_2 \leq m$. Remove s_{k_1} from its current category in organism O and attach it to cat_{k_2} (i.e., set $INST_O(s_{k_1}) = cat_{k_2}$).

Fitness Function

For the model, the fitness function is the sum of all satisfied predicates in the semantic net. Let F denote the function. Let $P_{ij}^{(g)}$ be defined as above, with m possible categories. Then

$$F = \sum_{j=1}^m \sum_{i=1}^m \sum_{g=1}^{r_{ij}} P_{ij}^{(g)} \quad (1)$$

$P_{ij}^{(g)}$ is a predicate for a relationship between categories, i and j . Each predicate $P_{ij}^{(g)}$ has a corresponding derived predicate, $pred_{ij}^{(g)}(k, l)$, for an analogous relationship between segments s_k and s_l , where s_k is in category i and s_l is in category j . $P_{ij}^{(g)}$ is interpreted based on the

normalized truth value of the derived predicate. Specifically,

$$P_{ij}^{(g)} = \begin{cases} \frac{\sum_{s_1} \sum_{s_k} \text{Pred}_{ij}^{(g)}(k, l)}{|\text{cat}_i| \times |\text{cat}_j|} & (2) \\ 0 & \text{otherwise} \end{cases}$$

where $|\text{cat}_i|$ and $|\text{cat}_j|$ are the number of segments classified as category i and category j , respectively. Because all such predicates are not defined between all possible pairs of segments, the normalizing factor (the denominator) is subject to redefinition on a case by case basis. Alternatives to (2) are described following the description of derived predicates below.

An example of a fuzzy predicate $P_{ij}^{(g)}$ from our domain is the relationship "is near", where category i "is near" category j . The corresponding derived predicate $\text{pred}_{ij}^{(g)}(k, l)$ describes the relationship between two segments, s_k in category i and s_l in category j . The sum of $\text{pred}_{ij}^{(g)}(k, l)$ for all possible pairs of segments s_k and s_l is normalized by the maximum possible.

Definitions of $\text{pred}_{ij}^{(g)}(k, l)$ are dependent on the underlying semantics of the problem domain. One approach is to define them propositionally as $\{0, 1\}$ if a measurable relationship between s_k and s_l is within or beyond some threshold. A second approach preferred here is to define them as fuzzy truth functions on the interval $[0, 1]$. Inverse exponential truth functions are commonly used in fuzzy set theory to measure the "nearness" of two concepts. An alternative nearness measures are in [ZI95]. For example, if the description of $P_{ij}^{(g)}$ contains a nominal value (e.g., the SW is approximately 50 kilometers from the NW) then let X_0 represent the nominal value and

$$\text{pred}_{ij}^{(g)}(k, l) = e^{-\beta |X_0 - X|} \quad (3)$$

where

X is the observed value corresponding to the same measure (distance, curvative, angle of declination) between s_k and s_l

β is a constant contrast factor in $[0, 1]$ which emphasizes the magnitude of the difference between the observed and nominal value when increased

There are many situations for which the nearness measure is not bounded by an ideal but the closer to s_k the better. In such cases, X_0 can be replaced by zero in formula (3).

"Not near" or "as distant as possible" may be measured by the fuzzy complement of (3).

$$\text{pred}_{ij}^{(g)}(k, l) = 1 - f() \quad (4)$$

where $f()$ is the right side of formula (3).

Some relationships such as "above" or "smaller" are not easily modelled as nearness measures.

Such relationships can be considered as ordinary propositional truth values.

$$\text{pred}_{ij}^{(g)}(k, l) = \begin{cases} 1 & \text{if } s_k \text{ and } s_l \text{ are so related} \\ 0 & \text{otherwise} \end{cases} \quad (5)$$

If there is a measure X associated with the relationship and $X_k > X_l$ when the condition is met, the derived predicate of formula (5) can be represented by the ceiling function

$$\text{pred}_{ij}^{(g)} = \lceil (X_k - X_l) / ((X_k - X_l) + 1) \rceil \quad (6)$$

For $P_{ij}^{(g)}$, each object attached to cat_i requires $|\text{cat}_j|$ evaluations of $\text{pred}_{ij}^{(g)}$. The multiple evaluations are combined to a single value using fuzzy OR

$$\max_{s_1} [\text{pred}_{ij}^{(g)}(k, l)]; \text{ for each } s_k \text{ in } \text{cat}_i \quad (7)$$

This corresponds to finding the best segment, s_1 , that matches the relationship for a given segment s_k . By contract, the combination rule

$$\min_{s_1} [\text{pred}_{ij}^{(g)}(k, l)]; \text{ for each } s_k \text{ in } \text{cat}_i \quad (8)$$

corresponds to fuzzy AND. The heuristic implied by the formula (2) is

$$\sum_{s_1} \text{pred}_{ij}^{(g)}(k, l) / |\text{cat}_j|; \text{ for each } s_k \text{ in } \text{cat}_i \quad (9)$$

which corresponds to the average truth functional value of s_k with all s_1 segments in cat_j .

Let $f_{ij}^{(g)}(k)$ stand for the segment level combination rule, (7), (8), or (9). Possible aggregation rules to compute $P_{ij}^{(g)}$ are

$$\sum_{s_k} f_{ij}^{(g)}(k) / |\text{cat}_i| \quad (10)$$

$$\max_k [f_{ij}^{(g)}(k)] \quad (11)$$

$$\min_k [f_{ij}^{(g)}(k)] \quad (12)$$

which correspond to average, best, and worst match, respectively. The aggregation rule of formula (10) is the one implied by formula (2).

EXAMPLE

Fig. 3 is a reproduction of Fig. 1(a) with most segments labelled (correctly). Eight segments are labelled as s_1, s_2, \dots, s_8 and are used below in an example. Table 1 lists and defines all predicates and derived predicates required for the semantic net of Fig. 2. The notation $|\text{cat}_h|$

Table 1. Predicate Descriptions

Predicate	Functional [Pred(k,l)]/normalizer	Description
$p_{cs,cs}^{(1)}$	$\max_x \{ \exp(-0.5 x) \} / coord $	near known CS coordinates (distance = x)
$p_{cs,cs}^{(2)}$	$\max_x \{ \exp(-0.5 x) \} / (cat_{cs} - 1)$ x where $k \neq l$	near other CS segment (distance = x)
$p_{we,we}^{(1)}$	$(1/ cat_{we}) \sum_x \{ \exp(-0.5 100-x) \} / cat_{we} $	WE diameter near 100 km (distance = x)
$p_{we,we}^{(2)}$	$\max_x \{ \exp(-0.5 x) \} / (cat_{we} - 1)$ x where $k \neq l$	near other WE segment (distance = x)
$p_{we,nw}^{(1)}$	$(1/ cat_{nw}) \sum_x \left[\frac{(X_k - X_l)}{(X_k - X_l + 1)} \right] / cat_{we} $	WE north of NW (X_k and X_l are latitudes)
$p_{nw,nw}^{(1)}$	$\max_x \{ \exp(-0.5 x) \} / (cat_{nw} - 1)$ x where $k \neq l$	near other NW segment (distance = x)
$p_{nw,sw}^{(1)}$	$(1/ cat_{sw}) \sum_x \{ \exp(-0.5 50-x) \} / cat_{nw} $	NW 50km from SW (distance = x)
$p_{nw,sw}^{(2)}$	$(1/ cat_{sw}) \sum_x \left[\frac{(X_k - X_l)}{(X_k - X_l + 1)} \right] / cat_{nw} $	NW north of SW (X_k and X_l are latitudes)
$p_{sw,sw}^{(1)}$	$\max_x \{ \exp(-0.5 x) \} / (cat_{sw} - 1)$ x where $k \neq l$	near other SW segment (distance = x)
$p_{sw,ce}^{(1)}$	$(1/ cat_{ce}) \sum_x \left[\frac{(X_k - X_l)}{(X_k - X_l + 1)} \right] / cat_{sw} $	SW north of CE (X_k and X_l are latitudes)
$p_{ce,ce}^{(1)}$	$(1/ cat_{ce}) \sum_x \{ \exp(-0.5 100-x) \} / cat_{ce} $	CE diameter near 100 km (distance = x)
$p_{ce,ce}^{(2)}$	$\max_x \{ \exp(-0.5 x) \} / (cat_{ce} - 1)$ x where $k \neq l$	near other CE segment (distance = x)
$p_{o,o}^{(1)}$	$\max_x \{ \exp(-0.5 x) \} / (cat_o - 1)$ x where $k \neq l$	near other O segment (distance = x)
$p_{o,o}^{(*)}$	$(1/ cat_o) \sum_x \{ 1 - \exp(-0.5 x) \} / cat_o $	not near CS, WE, CE, NW, or SW

refers to the number of segments that are an instance of category h. The value 0.5 is chosen arbitrarily for β in all derived predicates. The exponential form of derived predicates is used for all relationships except "north of" where formula (6) is substituted. The default value for any predicate or derived predicate is zero should a denominator evaluate to zero.

The eight segments distinguished in Fig. 3 are characterized in Table 2. For this example, we need only the geophysical coordinates, the distances between segment centroids, and the distances between the closest points of segments. A larger, more complete description might also contain the length and degree of curvature of each segment.

Table 3 lists six organisms together with their fitness function values which are computed using the predicates in Table 1. The fitness function is given by formula (2). The combination and aggregation rules are formulas (7) and (12), respectively. Derived predicates are variations

of formulas (3) and (4) except "north of", which is represented by formula (6) with the requisite measure being latitude. Organism O_1 has no segments labelled incorrectly. O_2 has two segments labelled incorrectly. O_3 through O_6 have 3, 3, 5, and 8 incorrectly labelled segments, respectively. The fitness function values correspond roughly to the correctness of the labelling. Additional predicates (i.e., a more complex semantic net) would improve upon the ordering and separation in most cases.

CONCLUSION

A model for labelling complex scenes via genetic algorithms with fuzzy fitness functions evaluated over semantic nets and GAs is possible. Truth functionals indicating the degree to which specific interfeature relationships are fulfilled are combined at the segment level then aggregated at the category level using fuzzy set operators.

We are currently investigating such issues as the effect of many predicates clustered on one or two



Figure 3. Segmented Image With Correct Labels

Table 2. Segment Descriptors

a. Centroid Position in Fractions of Latitude and Longitude

Segment	Latitude	Longitude
S ₁	39.48	70.04
S ₂	38.82	68.69
S ₃	39.52	66.84
S ₄	38.37	66.67
S ₅	37.33	66.72
S ₆	37.32	66.06
S ₇	38.07	65.81
S ₈	39.54	64.86

b. Distances Between Centroids (kilometers)

	S ₁	S ₂	S ₃	S ₄	S ₅	S ₆	S ₇	S ₈
S ₁	0.00	127.50	257.55	293.03	342.93	375.45	368.68	416.76
S ₂	127.50	0.00	164.60	168.39	217.12	247.96	243.55	316.35
S ₃	257.55	164.60	0.00	115.81	219.21	209.60	167.14	159.20
S ₄	293.03	168.39	115.81	0.00	104.08	98.13	75.67	186.73
S ₅	342.93	217.12	219.21	104.08	0.00	56.36	104.29	266.84
S ₆	375.45	247.96	209.60	98.13	56.36	0.00	58.67	223.86
S ₇	368.68	243.55	167.14	75.67	104.29	58.67	0.00	165.51
S ₈	416.76	316.35	159.20	186.73	266.84	223.86	165.51	0.00

c. Closest Proximities (kilometers)

	S ₁	S ₂	S ₃	S ₄	S ₅	S ₆	S ₇	S ₈
S ₁	0.00	127.13	-	-	-	-	-	-
S ₂	127.13	0.00	-	80.42	-	-	-	-
S ₃	-	-	0.00	31.26	-	-	42.80	-
S ₄	-	80.42	31.26	0.00	12.72	15.39	16.93	35.00
S ₅	-	-	-	12.72	0.00	0.00	-	-
S ₆	-	-	-	15.39	0.00	0.00	-	-
S ₇	-	-	42.80	16.93	-	-	0.00	20.92
S ₈	-	-	-	35.00	-	-	20.92	0.00

Table 3. Fitness Function Values for Selected Organisms

O_1	=	<NW SW NW SW CE CE CE CE>	:	$F(O_1)$	=	2.2098
O_2	=	<SW SW NW NW CE CA CE CE>	:	$F(O_2)$	=	2.2311
O_3	=	<NW SW NW NW CE CE NW SW>	:	$F(O_3)$	=	2.1251
O_4	=	<SW SW NW CE NW CE CE CE>	:	$F(O_4)$	=	1.4731
O_5	=	<NW NW CE CE SW NW SW CE>	:	$F(O_5)$	=	1.6757
O_6	=	<SW CE SW CE SW NW SW NW>	:	$F(O_6)$	=	0.9235

categories, alternate forms for the truth functionals themselves, and the crossover rules. Our image set consists of six segmented infrared photographs of the North Atlantic, each photograph having a different degree of observation. Our testbed will consist of a GA algorithm capable of manipulating the alleles' correspondence to the semantic net.

REFERENCES

- [B087] Booker, Lashon, "Improving Search in Genetic Algorithms", Genetic Algorithms and Simulated Annealing, Lawrence Davis, Ed., Morgan Kaufmann, Los Altos, CA, 1987, pp. 61-73.
- [G086] Goldberg, David E., "A Tale of Two Problems: Broad and Efficient Optimization Using Genetic Algorithms," Proc. of the Summer Computer Simulation Conference, July 28-30, 1986, Reno, Nevada.
- [G088] Goldberg, David E., Genetic Algorithms in Search, Optimization, and Machine Learning, Addison-Wesley, Reading, MA, 1988.
- [H075] Holland, John H., Adaption in Natural and Artificial Systems, University of Michigan Press, Ann Arbor, Michigan, 1975.
- [LC87] Lybanon, M. and R.L. Crout, "The NORDA GEOSAT Ocean Applications Program", John Hopkins APL Technical Digest, Vol 8, No. 2, April/June 1987, pp. 212-218.
- [RI83] Richardson, P.L., "Gulf Stream Rings", Eddies and Marine Science, A.R. Robinson (ed.), Springer Verlag, New York, 1983, pp. 19-45.
- [TB86] Thomason, Michael G. and Richard E. Blake, "Development of An Expert System for Interpretation of Oceanographic Images", NORDA Report 148, June 1986.
- [YA75] Yager, Ronald R. "Decision Making with Fuzzy Sets", Decision Sciences, Vol 6, 3, July 1975, pp. 590-600.
- [ZA88] Zadeh, Lotfi A., "Fuzzy Logic" Computer, Vol 21, 4, April 1988, pp. 83-93.
- [ZI85] Zimmermann, Hans -J., Fuzzy Set Theory and Its Applications, Kluwer Nijhoff Publishing, Dordrecht, The Netherlands, 1985.