

DTIC FILE COPY



Research Product 90-32

AD-A229 870

Implementation Guide for Assessing Intelligence Production Effectiveness

DTIC
ELECTE
DEC 10 1990
S E D

September 1990

Fort Huachuca Field Unit
Systems Research Laboratory

U.S. Army Research Institute for the Behavioral and Social Sciences

Approved for public release; distribution is unlimited.

90 12 7 042

U.S. ARMY RESEARCH INSTITUTE FOR THE BEHAVIORAL AND SOCIAL SCIENCES

A Field Operating Agency Under the Jurisdiction
of the Deputy Chief of Staff for Personnel

EDGAR M. JOHNSON
Technical Director

JON W. BLADES
COL, IN
Commanding

Research accomplished under contract for
the Department of the Army

Science Applications International Corporation

Technical review by

Joe Blair, III
Peter V. Huisking
Alexander M. Okimoto



Accession For	
NTIS GRA&I	<input checked="" type="checkbox"/>
DTIC TAB	<input type="checkbox"/>
Unannounced	<input type="checkbox"/>
Justification	
By _____	
Distribution/	
Availability Codes	
Dist	Avail and/or Special
A-1	

NOTICES

DISTRIBUTION: Primary distribution of this report has been made by ARI. Please address correspondence concerning distribution of reports to: U.S. Army Research Institute for the Behavioral and Social Sciences, ATTN: PERI-POX, 5001 Eisenhower Ave, Alexandria, Virginia 22353-5600.

FINAL DISPOSITION: This report may be destroyed when it is no longer needed. Please do not return it to the U.S. Army Research Institute for the Behavioral and Social Sciences.

NOTE: The findings in this report are not to be construed as an official Department of the Army position, unless so designated by other authorized documents.

REPORT DOCUMENTATION PAGE

Form Approved
 OMB No. 0704-0188

REPORT SECURITY CLASSIFICATION Classified		1b. RESTRICTIVE MARKINGS --	
SECURITY CLASSIFICATION AUTHORITY		3. DISTRIBUTION/AVAILABILITY OF REPORT Approved for public release; distribution is unlimited.	
DECLASSIFICATION/DOWNGRADING SCHEDULE			
PERFORMING ORGANIZATION REPORT NUMBER(S) C Report No. 89/1597		5. MONITORING ORGANIZATION REPORT NUMBER(S) ARI Research Product 90-32	
NAME OF PERFORMING ORGANIZATION ence Applications ernational Corporation (SAIC)	6b. OFFICE SYMBOL (if applicable)	7a. NAME OF MONITORING ORGANIZATION U.S. Army Research Institute Field Unit at Fort Huachuca	
ADDRESS (City, State, and ZIP Code) 09 Air Park Road SE buquerque, NM 87106		7b. ADDRESS (City, State, and ZIP Code) ATTN: PERI-SA Fort Huachuca, AZ 85613-7000	
NAME OF FUNDING/SPONSORING ORGANIZATION U.S. Army Research stitute for the Behavioral Social Sciences	8b. OFFICE SYMBOL (if applicable) PERI-S	9. PROCUREMENT INSTRUMENT IDENTIFICATION NUMBER MDA903-86-C-0435	
ADDRESS (City, State, and ZIP Code) 01 Eisenhower Avenue exandria, VA 22333-5600		10. SOURCE OF FUNDING NUMBERS	
		PROGRAM ELEMENT NO. 62785A	PROJECT NO. 790
		TASK NO. 1306	WORK UNIT ACCESSION NO. C01

TITLE (Include Security Classification)
 plementation Guide for Assessing Intelligence Production Effectiveness

PERSONAL AUTHOR(S) Burnstein, David (ARI); Fichtl, Theodore; Landee-Thompson, Betty;
 ompson, John (SAIC)

TYPE OF REPORT nal	13b. TIME COVERED FROM 86/09 TO 89/09	14. DATE OF REPORT (Year, Month, Day) 1990, September	15. PAGE COUNT
-----------------------	--	--	----------------

SUPPLEMENTARY NOTATION
 is project was technically monitored by Jo Hall and David Burnstein.

COSATI CODES			18. SUBJECT TERMS (Continue on reverse if necessary and identify by block number) Military intelligence Performance diagnostics Performance evaluation Field exercise evaluation Performance measurement
FIELD	GROUP	SUB-GROUP	

ABSTRACT (Continue on reverse if necessary and identify by block number)
 The methodology presented in the Implementation Guide for Assessing Intelligence
 oduction Effectiveness is driven by the users of intelligence. The Guide contains
 ocedures and forms that enable users of intelligence to identify and prioritize their
 telligence requirements, set standards for those requirements, and judge how well the
 quirements were met. The Guide also contains suggestions and forms for analyzing the
 er ratings, developing a diagnostic plan to determine the causes for deficiencies,
 nducting an inquiry, and providing feedback to the commander and G2.

DISTRIBUTION/AVAILABILITY OF ABSTRACT <input checked="" type="checkbox"/> UNCLASSIFIED/UNLIMITED <input type="checkbox"/> SAME AS RPT. <input type="checkbox"/> DTIC USERS		21. ABSTRACT SECURITY CLASSIFICATION Unclassified	
NAME OF RESPONSIBLE INDIVIDUAL David D. Burnstein		22b. TELEPHONE (Include Area Code) (602) 538-4704	22c. OFFICE SYMBOL PERI-SA

Research Product 90-32

Implementation Guide for Assessing Intelligence Production Effectiveness

David Burnstein

U.S. Army Research Institute

**Theodore Fichtl, Betty Landee-Thompson,
and John Thompson**

Science Applications International Corporation

Field Unit at Fort Huachuca, Arizona

Julie A. Hopson, Chief

Systems Research Laboratory

Robin L. Keesee, Director

U.S. Army Research Institute for the Behavioral and Social Sciences

5001 Eisenhower Avenue, Alexandria, Virginia 22333-5600

Office, Deputy Chief of Staff for Personnel

Department of the Army

September 1990

**Army Project Number
2Q162785A790**

**Human Performance Effectiveness
and Simulation**

Approved for public release; distribution is unlimited.

FOREWORD

A concern of the U.S. Army Intelligence Center and School is the development of methods for assessing military intelligence. The Implementation Guide for Assessing Military Intelligence provides the division commander and G2 a low cost method of determining how well intelligence is meeting the needs of the command. While the guide is primarily directed at assessment within an operational environment, it also has implications for instruction within the U.S. Army Intelligence Center and School.

The Implementation Guide is a result of research conducted within the Fort Huachuca Field Unit of the U.S. Army Research Institute for the Behavioral and Social Sciences under a contract to Science Applications International Corporation. The project was sponsored by the Directorate of Training and Doctrine, U.S. Army Intelligence Center and School, in a Letter of Agreement dated 14 March 1986. The Implementation Guide was provided to the Commander, U.S. Army Intelligence Center and School.



EDGAR M. JOHNSON
Technical Director

ACKNOWLEDGMENT

The authors are grateful to the 4th Infantry Division, Fort Carson, Colorado for permitting us to use its time and personnel to evaluate this methodology during a command post exercise. The lessons learned from implementing the methodology in the 4th Infantry Division exercise have been incorporated throughout this guide.

XX
FIELD TRAINING EXERCISE

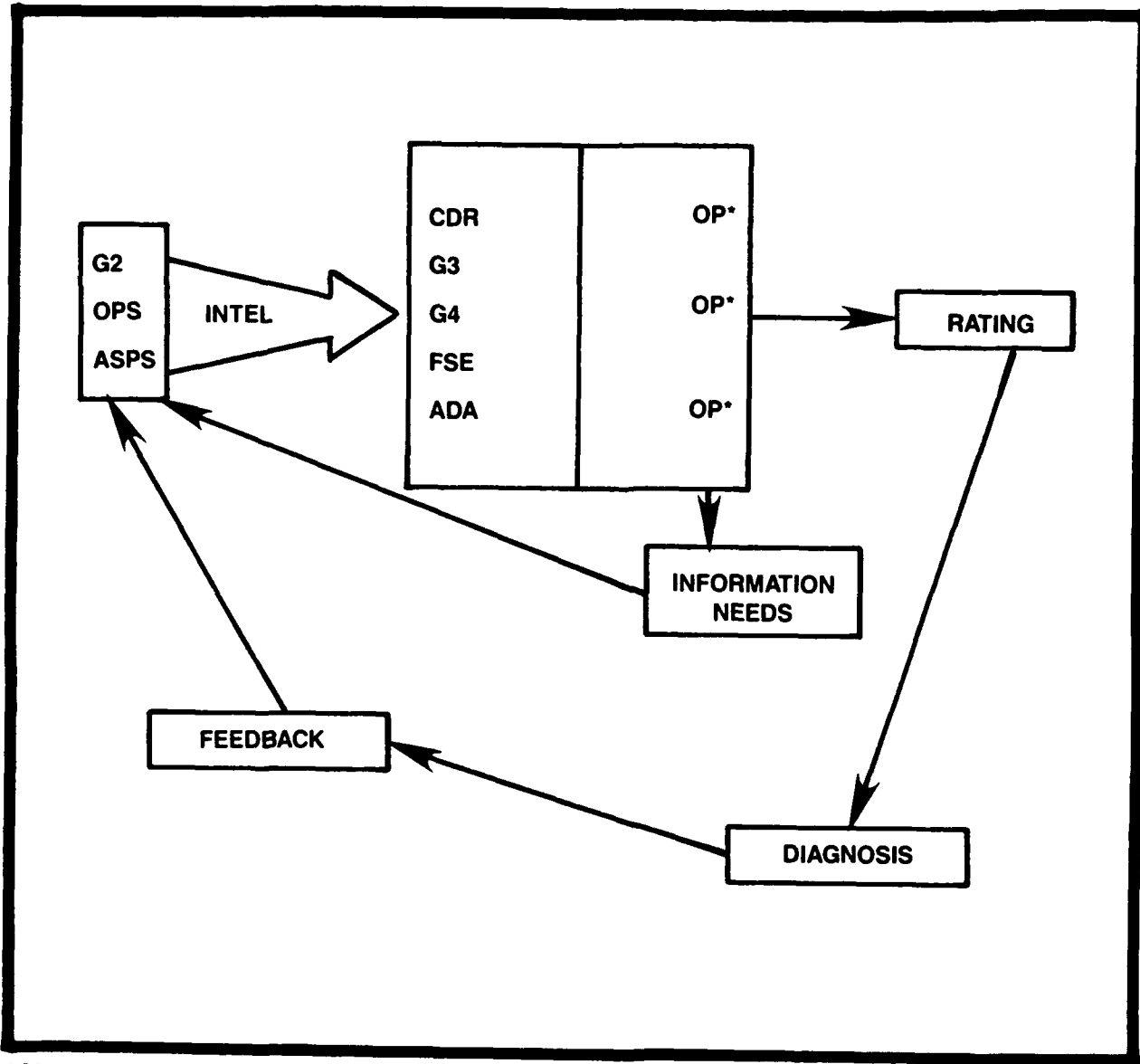

*Observer-Participant (See Section 2, Personnel)

The Assessment Methodology Includes Exchanges of
Information Needs, Rating, Diagnosis, and Feedback

IMPLEMENTATION GUIDE FOR ASSESSING INTELLIGENCE PRODUCTION EFFECTIVENESS

PROLOGUE

The schematic on the preceding page is a summary of the Military Intelligence Unit Effectiveness Assessment Methodology. It involves the exchange of information needs, the rating of intelligence output, the diagnosis of intelligence production deficiencies, and feedback to the commander and G2.

TO THE COMMANDER

As the commander, you have many tools to use to assess effectiveness within your command. The Skill Qualification Tests, the Army Training and Evaluation Programs, and your own internal assessment programs provide information you need to determine your command's capabilities to carry out its mission.

The method for assessing intelligence production effectiveness described in this guide is a tool designed for you to use in an operational setting to determine how well intelligence is meeting the needs of your command. The method can be used in command post or field training exercises where intelligence must serve many organizational elements or where intelligence production is limited.

This methodology has low overhead. It doesn't take a dedicated division team or outside team of evaluators to implement. It will provide you a pragmatic view of how the intelligence staff is supporting the divisional command and control. It also provides a way for the divisional personnel to improve their ability to communicate their intelligence information needs and the standards used to judge the intelligence. Finally, it provides a feeder mechanism for intelligence training that will enhance division command and control performance.

TO THE G2

This Implementation Guide for Assessing Intelligence Production provides you a tool for measuring and assessing how well your section meets the intelligence needs of the command. It permits you to look at performance inside the intelligence production system-based intelligence requirements, standards, and assessments from the division user. It provides you a method for isolating production areas that need improving from those that don't and can give you insight into how to improve the usefulness of intelligence for the user. In addition, the method will identify functional problems outside the intelligence infrastructure that may have been incorrectly attributed to Military Intelligence.

**IMPLEMENTATION GUIDE FOR ASSESSING INTELLIGENCE PRODUCTION
EFFECTIVENESS**

CONTENTS

	Page
INTRODUCTION	1
PERSONNEL.	3
Commander and G2.	3
Assessment Team Chief	3
Intelligence Users.	4
Diagnosticians.	4
ADMINISTRATIVE PROCEDURES.	5
Selecting the Team Members.	5
Briefing the Key Staff.	6
Training the Team	6
Conducting a Pre-exercise Conference.	8
Preparing Assessment Materials.	8
Rating MI Performance	8
Data Collection	9
Quality Control of the Data	9
INFORMATION REQUIREMENTS	11
Information Requirements Profile.	11
Description of the Profile.	11
Step 1, Procedures for Identifying and Prioritizing Information Requirements.	15
Importance of the Weighing.	19
Step 2, Determining the Standards for the Information.	19
Description of the Dimensions and Scales.	19
Determining the Benchmarks.	23
Administrative Considerations	24
RATING MILITARY INTELLIGENCE PERFORMANCE	27
Performance Rating Form	27
Description of the Rating Form.	27
Step 3, Rating Military Intelligence Performance.	27
Administrative Considerations	41
Summary	47
Importance of the Rating.	48

CONTENTS (Continued)

	Page
DIAGNOSING MILITARY INTELLIGENCE PERFORMANCE:	
ANALYZING THE RATINGS.	49
Deficiency Consolidation Worksheet.	49
Description of the Deficiency Consolidation Worksheet.	49
Step 4, Analyzing the Ratings: Consolidating the Performance Rating Form Data	49
Suggested Procedure for Completing the Worksheet.	53
Step 4, Analyzing the Ratings: Analyzing the Deficiency Consolidation Worksheet	59
Step 5, Determining Where Deficiencies Occur: Interpreting the Worksheet	63
DIAGNOSING MILITARY INTELLIGENCE PERFORMANCE:	
THE INQUIRY STRATEGY	69
The Planned Inquiry Guide	69
Description of the Planned Inquiry Guide.	69
Step 6, Develop a Diagnostic Plan: Using the Inquiry Guide.	69
Diagnostic Question Inventory	73
Step 7, Diagnosing the Intelligence Information Production System.	77
Recording the Results	77
Administrative Considerations	83
Summary	83
PROVIDING FEEDBACK	85
Periodic Feedback During the Exercise	85
Post-Exercise Feedback.	86
Analyzing the Deficiency Consolidation Worksheet.	86
APPENDIX A. SUPPLEMENTAL MATERIALS FOR IDENTIFYING AND PRIORITIZING INFORMATION REQUIREMENTS.	A-1
B. SUPPLEMENTAL MATERIALS FOR RATING MILITARY INTELLIGENCE PERFORMANCE	B-1
C. SUPPLEMENTAL MATERIALS FOR DIAGNOSING MILITARY INTELLIGENCE PERFORMANCE	C-1
D. COMPUTING SCORES FROM THE DEFICIENCY CONSOLIDATION WORKSHEET	D-1

CONTENTS (Continued)

Page

LIST OF FIGURES

Figure	1. Overview of the steps in the intelligence assessment methodology	2
	2. An example schedule for observer-participant training	7
	3. An information requirements profile form	13
	4. The information requirements profile completed for the most important items and the items not needed	17
	5. The weighed and reviewed information requirements profile	21
	6. The timeliness dimension and scale	23
	7. Time schedule for assessing MI effectiveness.	25
	8. Part 1 of the performance rating form.	29
	9. The performance rating form completed for timeliness	33
	10. Performance rating form with the frequency dimension completed.	37
	11. Performance rating form with operational perspective completed.	39
	12. Performance rating form with clarity dimension rated.	43
	13. A completed performance rating form.	45
	14. A deficiency consolidation worksheet	51
	15. A completed rating form for one observer, the G3 plans officer	55
	16. Data from figure 15 recorded on the deficiency consolidation worksheet.	57

CONTENTS (Continued)

	Page
Figure 17. A deficiency consolidation worksheet for five observer-participants	61
18. Deficiency consolidation worksheet	65
19. The planned inquiry guide form	71
20. The information item deficiency to source matrix form	74
21. Example questions from the diagnostic question inventory on timeliness	75
22. A completed planned inquiry guide.	79
23. A completed diagnostic record.	81

IMPLEMENTATION GUIDE FOR ASSESSING INTELLIGENCE PRODUCTION EFFECTIVENESS

SECTION 1

INTRODUCTION

The methodology presented in the Implementation Guide is driven by the users of intelligence. It depends on users identifying their intelligence requirements and judging how well the requirements have been met. Figure 1 shows the steps required in the assessment. Using the tools provided, the user of intelligence first identifies and prioritizes his information requirements. Then, using a simple procedure, he determines the standards he uses to judge the information he receives. Finally, he rates the information he received. The analysis of the ratings results in a pattern of intelligence production performance that is used to determine where deficiencies might be occurring within the intelligence production process. The ratings are also used to develop a diagnostic plan to determine the causes for the deficiencies. Then the intelligence production system is diagnosed. The result of the diagnosis, along with the patterns of performance and the ratings, form the basis of the feedback to the commander and G2.

Organization of the Implementation Guide

Section 2 covers who is involved in the assessment. It describes the qualifications the participants should have and the roles they play in the assessment. Section 3 discusses the administrative procedures necessary to plan and implement the assessment. The next four sections, identified in Figure 1, cover the steps necessary to carry out the assessment, diagnosis, and feedback. Each step includes the procedures and forms necessary to carry out the step and administrative concerns relevant to the completion of the step. Section 4 covers the procedures necessary to identify and prioritize the information requirements and identify standards used to assess intelligence. Section 5 discusses the steps the user must take to rate the information received from intelligence. Section 6 provides suggestions for analyzing the user ratings. Section 7 provides guidelines for planning and diagnosing intelligence production deficiencies. Section 8 offers suggestions for providing feedback.

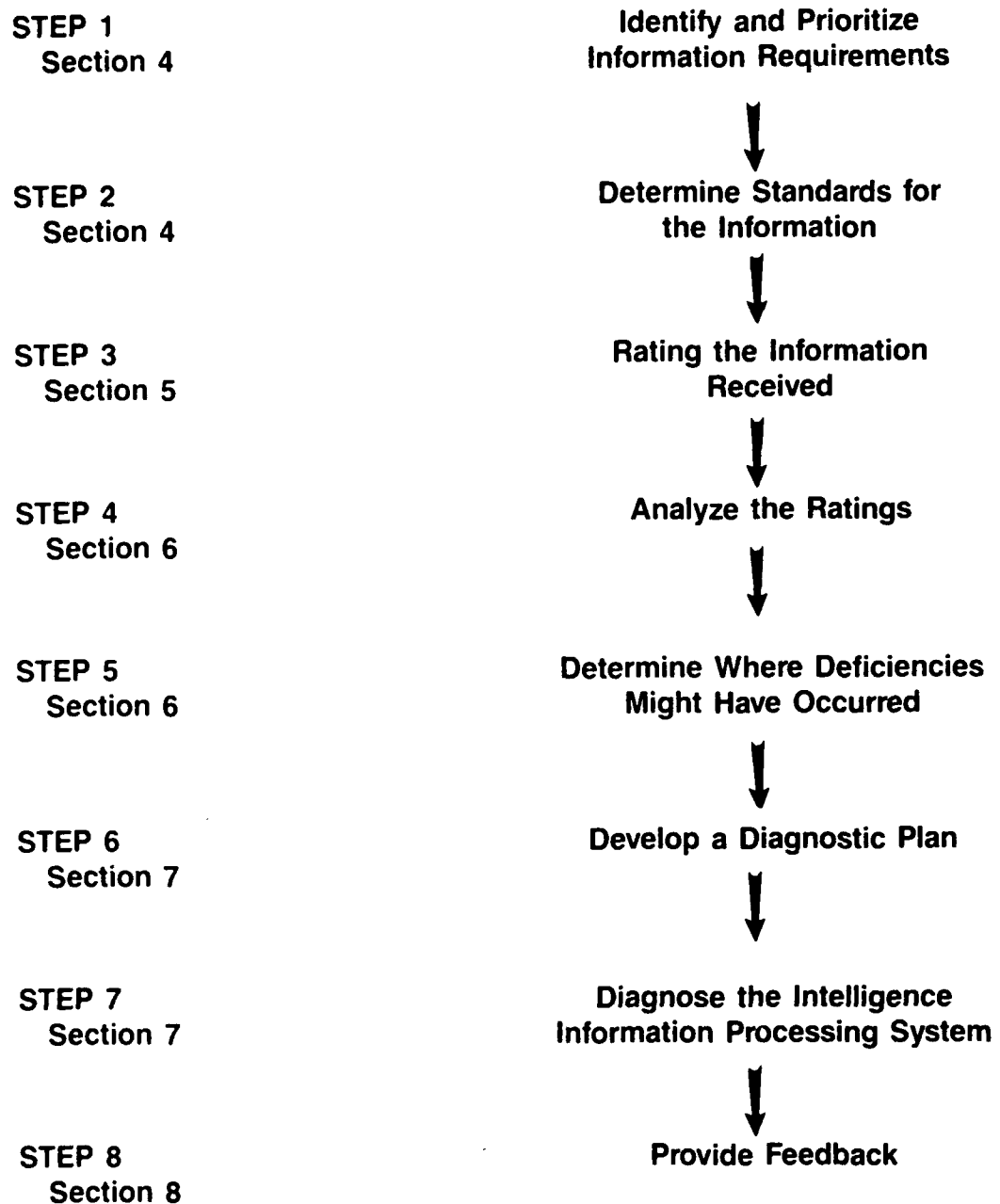

Figure 1. Overview of the steps in the intelligence assessment methodology.

SECTION 2

PERSONNEL

The assessment methodology is implemented by a team of soldiers each having specific responsibilities, some which are done individually and others done as part of the team effort. This section identifies the team members, their roles, and general qualifications. The team has three roles: the administration of the assessment, the assessment of Military Intelligence performance, and the diagnosis of deficiencies in the production of intelligence. The size of the team is as large or as small as is warranted by the exercise and assessment objectives.

A. COMMANDER AND G2.

Although the commander and the G2 may not be involved in the actual assessment, they are critical to the assessment. They have made the decision to do the assessment and it is carried out under their authority. The results of the assessment are provided to the G2 and the commander through the G2. Therefore, each has a vested interest to ensure the assessment is conducted as completely, effectively, and efficiently as possible.

B. ASSESSMENT TEAM CHIEF.

Role: The assessment team chief manages the assessment. He is the administrative component of the assessment team. He is responsible for assembling and training the other team members. With assistance of the other team members, he determines how the assessment methodology can best be implemented, ensures the other teams members have the time and resources to carry out their functions, and serves as the liaison for the team.

Qualifications: The assessment team chief should be knowledgeable of the division intelligence operations and personnel. He should be able to easily communicate with personnel at all levels of the division command and within its operations.

Suggested Candidate: Deputy G2 or Military Intelligence Battalion Executive Officer

C. INTELLIGENCE USERS.

Role: The users of intelligence are the soldiers who will assess how well the intelligence information production system is working. They are active participants in the exercise and at the same time assess how well the information received met their intelligence needs. Because they are active participants, they will be referred to as **OBSERVER-PARTICIPANTS** in the rest of this guide.

Qualifications: Since the observer-participants are active participants in the exercise, it is required they have some knowledge and experience in the mission related role they will be playing.

Suggested Candidate: Officers from G3 Operations and Plans, the Fire Support Element, Targeting, the Division Airspace Management Element (DAME), etc. Representatives of subordinate command echelons may be included.

D. DIAGNOSTICIANS.

Role: The diagnostician will try to determine the reasons for the deficiencies identified by the observer-participants.

Qualifications: The diagnostician must have experience in Military Intelligence and know intelligence doctrine. He must know or learn the Standard Operating Procedures for the division G2 section being assessed.

Suggested Candidate: Any senior 350B Military Intelligence Warrant Officer.

SECTION 3

ADMINISTRATIVE PROCEDURES

While the administrative burden for the assessment falls on the assessment team chief, all members of the team should be aware of the overall requirements of the methodology. This will help each person better understand the various roles and how everyone contributes to the assessment.

The administrative procedures concern those involved in planning and organizing the assessment and those that must be carried out during the exercise.

A. SELECTING THE TEAM MEMBERS.

Assessment Team Chief: The commander or his designate must make this selection.

Observer-Participants: The assessment team chief should prepare a list of recommended observer-participants representative of key division staff agencies and functions. Approval of the list should be made by the commander or his designee. How many and who should be on the list depends on the purpose and desired scope of the assessment.

EXAMPLE

If the assessment is to be conducted in a short duration--2 5 days--division headquarters and staff command post exercise intended to shake out staff planning procedures, the observer-participants may be limited to one from G3 Plans and one from G3 OPS.

If the assessment is to be conducted during a Divisional Field Training Exercise with a control cell and all organization elements, maneuver and staff, participating or conducting operations, then numerous observer-participants are needed to ensure assessment of the

broadest aspects of intelligence production and support. All staff agencies, selected special staff, and alternate command posts should be considered.

Diagnostician:

The team chief should submit a name for approval to the commander or his designee based on the qualifications mentioned previously. One diagnostician is enough unless the exercise environment is so extensive that it might require full shift coverage for diagnosis.

Upon approval, team members should be made available for the assessment training at least two weeks before the start of the exercise. Two weeks is a rule of thumb, but team members must be trained and exercise administrative details worked out before the assessment can be implemented.

In addition, the assessment team chief must perform the following administrative duties:

B. BRIEFING THE KEY STAFF.

While the commander may have informed his staff an assessment will be done, it is a good idea to provide key staff members more detail. Since headquarters or unit soldiers are being used as observer-participants, it is only right that the key staff members know who from their staff are participating, what is going to be done, and how much time it is going to take. In fact, the key staff should be consulted for recommendations for the observer-participants roles.

If a group briefing can not be done, each key staff member must be told what the assessment entails. This may be done if and when the key staff is consulted to provide names for the assessment team.

C. TRAINING THE TEAM.

It is the responsibility of the team chief to train the rest of the team. If this is the first time he has administered an assessment, his knowledge will be as limited as the other team members. The training should be considered a team effort, with team members helping each other. An example training-time plan is shown in Figure 2. The events can occur within the windows indicated by the triangles, but no later. To facilitate such a situation, all team members need to receive copies of the

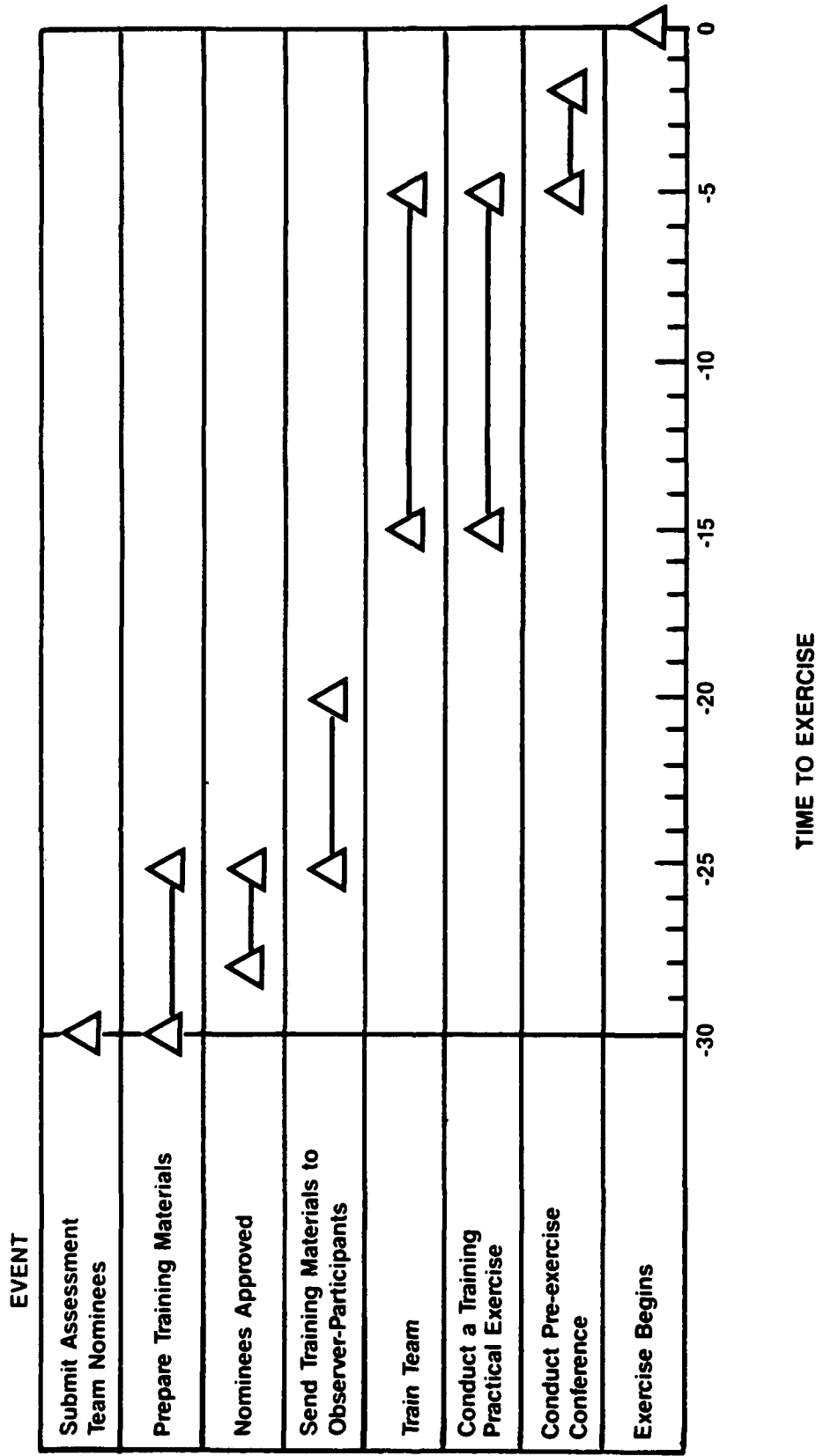

Figure 2. An example schedule for observer-participant training.

implementation guide well before the scheduled training period. By training time, everyone should be prepared to discuss the assessment procedures.

NO LESS THAN 8 HOURS SHOULD BE ALLOTTED FOR ASSESSMENT TEAM TRAINING TIME. THE SUCCESS OF THE ASSESSMENT IS BUILT UPON THE ACCOMPLISHMENT OF THE PREASSESSMENT TRAINING.

The goal of the training is to ensure that everyone--team chief, observer-participants, and diagnostician--knows what forms to use and when and how to use them. If possible, a practical exercise should be part of the training to give the observer-participants experience filling in the forms. Also, the observer-participants need to know how the data they produce will be analyzed so that it can be used by the diagnostician. Finally, everyone needs to know the administrative procedures that will be followed during the exercise. These procedures need to be established during the team training meeting.

D. CONDUCTING A PRE-EXERCISE CONFERENCE.

The entire team must meet before the exercise begins. The purposes of this meeting are to review the assessment administrative procedures that will be in effect, hand out and ensure everyone has enough forms, and obtain the initial information requirements profile and benchmarks from the observer-participants.

E. PREPARING ASSESSMENT MATERIALS.

All team members must have a copy of the Implementation Guide for their training. All the forms, in the appropriate quantities, needed by the observer-participants and diagnostician should be provided at the preconference exercise. Blank forms are in the appendices and can be reproduced in whatever quantity is necessary.

There are administrative assessment procedures for which the team chief should get input from the observer-participants. The details of these procedures need to be determined during the training session.

F. RATING MI PERFORMANCE.

The team should decide the best time in each exercise day to rate MI performance. The best time may depend on the nature and length of the exercise, as well as the objectives for the assessment. Whatever the time frame for rating, all observer-participants must rate MI performance within the same time window.

In determining when to rate, the team should consider:

The amount of intelligence each observer-participant will be getting within the selected time interval. The interval should not be so long that it would be difficult to remember the intelligence that had been used, nor so short that there is little to assess.

The natural breaks which provide good assessment points. For example, at the end of shift or before the beginning of the next shift may be good times to take the time necessary to do the rating. Also, natural phases of the exercise are meaningful points to assess. For example, rating after the planning phase, after an attack, etc., assess how well intelligence was provided for that phase.

The observer-participants duties and responsibilities during the exercise. It takes time to rate. Even though the observer-participant is committed to assessing, he is still an active player and the assessment can not interfere with the exercise.

If it becomes necessary to change the rating period, the assessment team chief must inform all members of the team so they can rate within the new time window.

G. DATA COLLECTION.

Ratings must be analyzed by the team chief and diagnostician in order for the diagnostician to carry out his function. The team should determine the time window to complete the rating and the best means to get the ratings to the team chief. Most likely, how the ratings are delivered will depend on the physical layout of the exercise and the distribution of observer-participants within it.

H. QUALITY CONTROL OF THE DATA.

The success of the assessment depends on the quality of the data that is collected. Each individual on the team knows what is required of him and how to accomplish his responsibilities. Each is responsible for the quality control of their own data. If the diagnostician or the observer-participants run into any problems in data collection that they cannot resolve, they need to take the problem to the team chief immediately.

Additional administrative concerns are addressed later in each section.

SECTION 4

INFORMATION REQUIREMENTS

The assessment of MI information production effectiveness is based on how well MI has satisfied the information requirements of the observer-participant. The first step in the assessment is to determine the information requirements of the various observer-participants. This is done by the observer-participants assigning weights to the information items in a list of information requirements. The weights produce an information requirements profile. Once weighed, the observer-participant determines the standards he will use to judge the information he receives (Step 2).

A. INFORMATION REQUIREMENTS PROFILE.

A copy of a blank Information Requirements Profile is shown in Figure 3. A copy of the profile, the definitions of the terms in the profile, and a complete set of directions for weighing the items are in Appendix A.

B. DESCRIPTION OF THE PROFILE.

In the box at the top left corner of the Information Requirements Profile are abbreviated instructions on how to complete the profile. The first time the form is completed, the full set of directions (Appendix A-2) need to be used. After that, the abbreviated set can be used.

Below the instructions in the left hand vertical column is the list of information requirements. The column is divided into four major sections:

BATTLEFIELD AREA
ENEMY SITUATION
ENEMY COURSES OF ACTION
OPERATIONS SECURITY

These headings characterize the kind of information item found in the section. They also provide the most general level of definition.

Each of the major sections are broken down into sub-sections. For example, BATTLEFIELD AREA has three kinds of information items, weather, terrain, and battlefield area conditions. The subsections also have general definitions.

Each subsection contains the information items. Each item has a more specific definition than the major sections or subsections. The individual information items will be weighed.

INFORMATION REQUIREMENTS PROFILE

- INSTRUCTIONS:**
1. Assign zero to any information items you do not want.
 2. Assign 100 to your most important information items.
 3. Assign a number between 0 and 100 to remaining items to reflect the relative importance of the item.
 4. List specific data items you want emphasized under special notes

NAME _____

POSITION _____

DATE _____

		IMPORTANCE WEIGHT (0 - 100)	SPECIAL NOTES
BATTLEFIELD AREA	Weather		
	Weather situation		
	Weather effects on EN		
	Weather effects on FR		
	Terrain		
	Terrain situation		
	Terrain effects on EN		
	Terrain effects on FR		
	Battlefield area conditions		
	Existing battlefield conditions		
Effects on EN operations			
Effects on FR operations			
ENEMY SITUATION	EN Disposition and composition		
	Forward trace		
	Unit locations		
	Main efforts		
	Combat support		
	Echelonment		
	Reserves		
	Staging areas		
	Combat service support		
	Air Forces		
	C2		
	Strength of EN forces by echelon		
	Readiness by echelon		
	Supply status/rates by echelon		
	Enemy critical nodes/HPTs		
	Level of EN morale		
	Strength of Air Forces		
	NBC		
	Recent/present significant activities		
	Combat action		
Maneuver/movement			
C2 activity			
Sustainment			
Intelligence activities			
ENEMY COURSES OF ACTION	Enumerate Possible ECOAs		
	Mission		
	Objectives		
	Forces		
	Terrain considerations		
	Echelonment		
	Main/supporting efforts		
	Fires (including air support)		
	Time/Distance factors		
	Threat advance		
	Probability		
	Analysis of Probable ECOAs		
	Enemy strengths		
	EN Vulnerabilities		
	Friendly high value targets		
Enemy intentions			
OPERATIONS SECURITY	EN RECCE/Intelligence		
	EN RECCE/Intelligence capabilities		
	Recent RECCE/Intelligence activities/Indicators		
	Effects of EN Intelligence on FR operations		
	EN Radio Electronic Combat		
	REC capabilities		
	Recent & significant REC activities		
	Effects of REC on FR operations		
	EN Special Operations		
	EN special operations capabilities		
	Recent/significant EN special operations		
	Effects of EN special operations on FR operations		
	Friendly Vulnerabilities		
	Friendly high value targets		
	Effects of vulnerabilities on FR operations		
Deception			
Deception capabilities			
Recent/significant deception activities			
Effects of deception on FR operations			

Figure 3. An Information Requirements Profile Form

In the center column, the observer-participant places the weights he assigns the information item.

The "special notes column" is not part of the weighing procedure. The observer-participant can identify specific requirements concerning that item.

EXAMPLE An observer-participant may not only be interested in the weather situation in general, but may also be interested if there will be 30 mph winds between 0400 and 0600. He would make that note in the special notes column.

C. STEP 1, PROCEDURES FOR IDENTIFYING AND PRIORITIZING INFORMATION REQUIREMENTS.

1. Reviewing the Information Items.

The observer-participant reviews each item and its definition (Appendix A-3) to ensure he knows their meaning. The definitions should be referred to during weighing when the observer-participant has any doubt about the meaning of an item. The review is an important step because it helps establish consistent meanings for an observer-participant and between different observer-participants.

2. Initial Weighing.

All items are reviewed as to their importance within the specific rating period. For example, if the rating period is the planning phase, the importance of the items would be relative to the planning phase.

The items that are most important are given 100 points. If there are any items the observer-participant does not want during that period, they are given a 0. There is no limit to the number of items that can be given 100 or 0.

EXAMPLE As seen in Figure 4, the most important items and the items not needed have been identified. Seven items were identified as being most important, i.e., given 100 points. Two items were not needed, i.e., given 0 points. The items without assigned weights are needed, but are less important than those having the 100. Every remaining item in the requirements list must have a weight from 0 to 100.

INFORMATION REQUIREMENTS PROFILE

INSTRUCTIONS:

1. Assign zero to any information items you do not want.
2. Assign 100 to your most important information items.
3. Assign a number between 0 and 100 to remaining items to reflect the relative importance of the item.
4. List specific data items you want emphasized under special notes

NAME _____
 POSITION _____
 DATE _____

		IMPORTANCE WEIGHT (0 - 100)	SPECIAL NOTES
BATTLEFIELD AREA	Weather		
	Weather situation		
	Weather effects on EN		
	Weather effects on FR		
	Terrain		
	Terrain situation		
	Terrain effects on EN		
	Terrain effects on FR		
	Battlefield area conditions		
	Existing battlefield conditions		
Effects on EN operations			
Effects on FR operations			
ENEMY SITUATION	EN Disposition and composition		
	Forward trace	100	
	Unit locations	100	
	Main efforts	100	
	Combat support		
	Echelonment		
	Reserves		
	Staging areas		
	Combat service support		
	Air Forces		
	C2		
	Strength of EN forces by echelon		
	Readiness by echelon		
	Supply status/rates by echelon		
	Enemy critical nodes/HPTs	100	
	Level of EN morale	0	
	Strength of Air Forces		
	NBC		
	Recent/present significant activities		
	Combat action	100	
Maneuver/movement			
C2 activity			
Sustainment			
Intelligence activities			
ENEMY COURSES OF ACTION	Enumerate Possible ECOAs		
	Mission		
	Objectives		
	Forces		
	Terrain considerations		
	Echelonment		
	Main/supporting efforts		
	Fires (including air support)		
	Time/Distance factors	100	
	Threat advance		
	Probability	100	
	Analysis of Probable ECOAs		
	Enemy strengths		
	EN Vulnerabilities		
	Friendly high value targets		
Enemy intentions			
OPERATIONS SECURITY	EN RECCE/Intelligence		
	EN RECCE/Intelligence capabilities		
	Recent RECCE/Intelligence activities/Indicators		
	Effects of EN intelligence on FR operations		
	EN Radio Electronic Combat		
	REC capabilities		
	Recent & significant REC activities		
	Effects of REC on FR operations		
	EN Special Operations		
	EN special operations capabilities	0	
	Recent/significant EN special operations		
	Effects of EN special operations on FR operations		
	Friendly Vulnerabilities		
	Friendly high value targets		
	Effects of vulnerabilities on FR operations		
Deception			
Deception capabilities			
Recent/significant deception activities			
Effects of deception on FR operations			

Figure 4. The Information Requirements Profile completed for the most important items and the items not needed.

3. Determining Relative Weights.

The remaining items, one at a time are compared to the items given the weight of 100. The question which needs to be answered is, how important is that item, compared to the most important items. The item is given points accordingly. For example, if the item was half as important it would be given 50; if the item was almost as important, but not quite, it might be given a 90; if the item was needed but not very important in relation to the most important items, it might be given a 10 or 15; and if the item is as important as the other 100s, it is given 100.

4. Review of Weights.

The weights need to be reviewed to ensure that all items have been weighed and the reviewer has a chance to look at all the weighings as a group. Any changes to the weights can be made at this time, as illustrated in Figure 5.

D. IMPORTANCE OF THE WEIGHING.

The weights are used in the assessment procedure to determine how well MI has met the observer-participant's needs. The weights may also be used to determine priorities for diagnosing the information production function.

E. STEP 2, DETERMINING THE STANDARDS FOR THE INFORMATION.

It is necessary for the observer-participant to determine the standards he will use to assess the information he receives from intelligence. This is done by identifying, on a series of scales, the point where acceptable information becomes unacceptable. This point is the benchmark for later determining MI effectiveness. There are five dimensions which can be used to assess information: timeliness, frequency, operational perspective, clarity, and completeness.

F. DESCRIPTION OF THE DIMENSIONS AND SCALES.

The five dimensions with their scale and the directions for setting benchmarks are found in Appendix A. The timeliness dimension and scale is shown in Figure 6. Since each of the scales for the five dimensions are in the same format, only one is described. At the top of the page is the name of the dimension, Timeliness, in this case. Next is the definition and explanation

INFORMATION REQUIREMENTS PROFILE

- INSTRUCTIONS:**
1. Assign zero to any information items you do not want.
 2. Assign 100 to your most important information items.
 3. Assign a number between 0 and 100 to remaining items to reflect the relative importance of the item.
 4. List specific data items you want emphasized under special notes

NAME _____
 POSITION _____
 DATE _____

	IMPORTANCE WEIGHT (0 - 100)	SPECIAL NOTES
BATTLEFIELD AREA	<i>Weather</i>	
	Weather situation	70
	Weather effects on EN	60
	Weather effects on FR	50
	<i>Terrain</i>	
	Terrain situation	80
	Terrain effects on EN	70
	Terrain effects on FR	60
	<i>Battlefield area conditions</i>	
	Existing battlefield conditions	90
Effects on EN operations	80	
Effects on FR operations	70	
ENEMY SITUATION	<i>EN Disposition and composition</i>	
	Forward trace	100 90
	Unit locations	100 80
	Main efforts	100 70
	Combat support	60
	Echelonment	50
	Reserves	70
	Staging areas	60
	Combat service support	60
	Air Forces	30
	C2	80
	<i>Strength of EN forces by echelon</i>	
	Readiness by echelon	80
	Supply status/rates by echelon	60
	Enemy critical nodes/HPTs	100
	Level of EN morale	20 0
	Strength of Air Forces	40
	NBC	60
	<i>Recent/present significant activities</i>	
	Combat action	100
Maneuver/movement	80	
C2 activity	70	
Sustainment	60	
Intelligence activities	60	
ENEMY COURSES OF ACTION	<i>Enumerate Possible ECOAs</i>	
	Mission	70
	Objectives	80
	Forces	80
	Terrain considerations	60
	Echelonment	60 40
	Main/supporting efforts	70
	Fires (including air support)	80
	Time/Distance factors	100
	Threat advance	70
	Probability	100
	<i>Analysis of Probable ECOAs</i>	
	Enemy strengths	80
	EN Vulnerabilities	70
	Friendly high value targets	40
Enemy intentions	90	
OPERATIONS SECURITY	<i>EN RECCE/Intelligence</i>	
	EN RECCE/Intelligence capabilities	30
	Recent RECCE/Intelligence activities/indicators	20
	Effects of EN Intelligence on FR operations	20
	<i>EN Radio Electronic Combat</i>	
	REC capabilities	30
	Recent & significant REC activities	20
	Effects of REC on FR operations	20
	<i>EN Special Operations</i>	
	EN special operations capabilities	0
	Recent/significant EN special operations	30
	Effects of EN special operations on FR operations	20
	<i>Friendly Vulnerabilities</i>	
	Friendly high value targets	20
	Effects of vulnerabilities on FR operations	30
<i>Deception</i>		
Deception capabilities	10 0	
Recent/significant deception activities	20	
Effects of deception on FR operations	20	

Figure 5. The weighed and reviewed information Requirements Profile.

TIMELINESS

TIMELINESS - is a measure of whether the information item was received in time for the user to take action on it. Timeliness applies to situations where there is no stated operational deadline for the information, but a window exists during which the user must take action based on that specific information.

Timeliness Scale:

1. Item received and user had ample time to take operational action within the time window.
2. Item received in time to take action, but user had to rush.
3. Item received in time to take action, but user had to rush and use additional resources.

4. Item received too late for user to take action.
5. Item not received.

FIGURE 6. The timeliness dimension and scale.

of the dimension. Following the definition is the scale. It has five levels numbered 1 through 5. One (1) on the scale is meant to represent the best possible case, the 5 is meant to represent the worst case. The items in between represent different degrees of performance between the best and worst cases.

G. DETERMINING THE BENCHMARKS.

1. For any dimension review the five levels of performance indicated by the scales.
2. Select the point on the scale that best describes the minimum level of performance which would be acceptable to you.
3. Draw a line under that scale number.
4. Review the items under that line to ensure they describe performance unacceptable to you. If not, redetermine the benchmark.

EXAMPLE

As seen in Figure 6, a line has been drawn between Items 3 and 4. Therefore, any item rated 4 or 5 by the observer-participant indicates unacceptable performance on timeliness.

H. ADMINISTRATIVE CONSIDERATIONS.

Initial weighing and setting benchmarks are done during the preexercise conference and subsequently during the exercise within the time windows determined by the assessment team. The new weights and benchmarks completed during the exercise should be turned over to the team chief with the rating form. During the exercise, weighing and setting benchmarks will always take place after the rating and will be done in relation to the next rating period.

EXAMPLE

The time schedule shown in Figure 7 indicates that the first weighing is done in the preexercise conference, which is held within two days of the exercise start. The rating period for the exercise is 12 hours. Within the window the assessment of MI performance for the preceding 12 hours occurs. When that is completed, the second weighing is done for the next 12 hour period. The cycle continues for the 48 hour exercise shown. The arrows pointing to left indicate the assessment is for previous 12 hours. In contrast, arrows to the right indicate that weighing is to be done in terms of the next 12 hours.

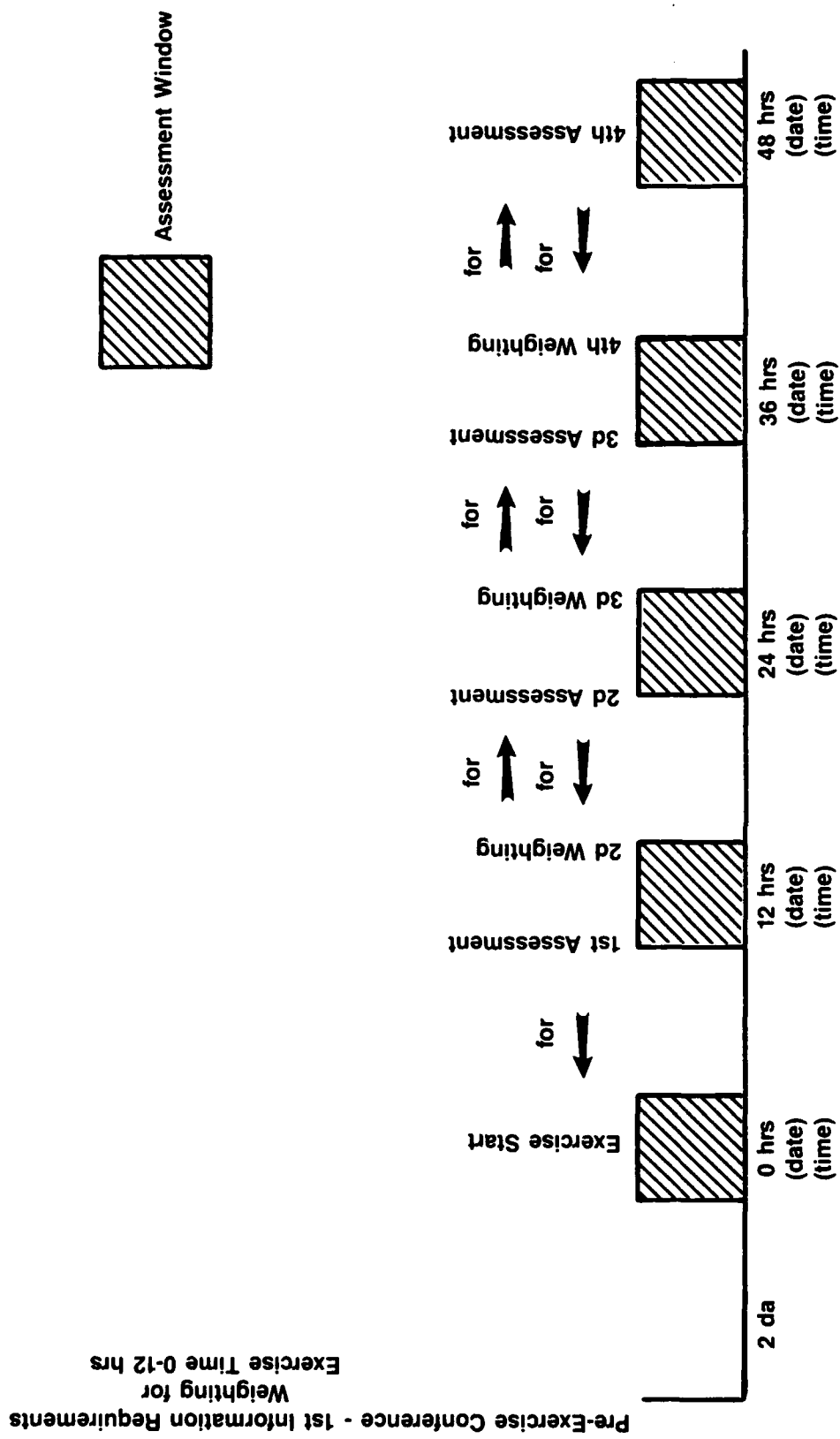

Figure 7. Time schedule for assessing MI effectiveness.

SECTION 5

RATING MILITARY INTELLIGENCE PERFORMANCE

Sometime after the observer-participants begin to receive and use intelligence, they will rate how well the information met their requirements. Each item will be assessed and rated on the five dimensions for the rating period previously determined. The ratings will be analyzed by the team chief and diagnostician. The analysis will form the basis for the diagnosis of the intelligence production system and performance feedback to the commander and G2.

A. PERFORMANCE RATING FORM.

A blank copy of Part 1 of the Performance Rating Form is shown in Figure 8. Part 2 follows the same format. A copy of the rating form and instructions on how to do the rating are in Appendix B.

B. DESCRIPTION OF THE RATING FORM.

At the left of the rating form is the column containing the five dimensions used to rate the information items. Each dimension, timeliness, frequency, operational perspective, clarity, and completeness are described by five point scales. The description for each level of the scale is abbreviated. The complete scales are located in Appendix A. There is also a box to check in order to identify the benchmark.

The next column gives examples of the kinds of deficiencies that could occur for the dimension on the left. The lists are not inclusive.

The third column contains the information item. These are the same items, in the same format, that are in the Information Requirements Profile. To the right of the information items are the columns to be filled in when rating intelligence performance. Each column is headed by the dimension on which the information item will be rated.

C. STEP 3, RATING MILITARY INTELLIGENCE PERFORMANCE.

1. Review the Five Scales.

When the time window opens for the first rating of the information items, the observer-participant should review the definitions and scales for the five dimensions (Appendix A). On later ratings, the review needs to be done only as necessary since abbreviated scales are on the rating forms.

Performance Rating Form

(part 1 of 2)

NAME _____
 POSITION _____
 DATE _____

TIMELINESS RATING (1-5)	FREQUENCY RATING (1-5)	OPERATIONAL PERSPECTIVE DEFICIENCIES	CLARITY DEFICIENCIES	COMPLETENESS RATING (1-5)
		WEATHER Weather situation Weather effects on EN Weather effects on FR		
		TERRAIN Terrain situation Terrain effects on EN Terrain effects on FR		
		BATTLEFIELD AREA CONDITIONS Existing battlefield conditions Effects on EN operations Effects on FR operations		
		EN DISPOSITION AND COMPOSITION Forward traces Unit locations Main efforts Combat support Echelonnement Reserves Staging areas Combat service support		
		AIR FORCES C2 Strength of EN Forces by Echelon Readiness by echelon Supply status/rates by echelon Enemy critical nodes/HPTs Level of EN morale Strength of Air Forces NBC		
		RECENT/PRESENT SIGNIFICANT ACTIVITIES Combat action Maneuver/movement C2 activity Sustainment Intelligence activities		

TIMELINESS RATINGS
 Benchmark Rating
 Check one: 1 Received in ample time
 2 Received, had to rush
 3 Received, required extra resources
 4 Received too late
 5 Did not receive

FREQUENCY RATINGS
 Benchmark Rating
 Check one: 1 Often enough
 2 Too often but manageable
 3 Too often and disruptive
 4 Not often enough
 5 Did not receive

OPERATIONAL PERSPECTIVE RATINGS
 Benchmark Rating
 Check one: 1 None, different perspective
 2 Relates to key aspects of current/future ops
 3 Relates to some aspects of current/future ops
 4 Does not relate to current/future ops
 5 No perspective provided

CLARITY RATINGS
 Benchmark Rating
 Check one: 1 Easy to understand
 2 Easy to understand with comparison
 3 Understandable with identification
 4 Required extensive identification to understand
 5 Not understandable

COMPLETENESS RATINGS
 Benchmark Rating
 Check one: 1 No gaps
 2 Some gaps though explained
 3 Some gaps with no explanations
 4 Many gaps with no explanations
 5 Too many gaps to see

SAMPLE OPERATIONAL PERSPECTIVE DEFICIENCIES
 OPERATIONAL PERSPECTIVE NOT RELATED TO:
 A Area of Operations
 B Area of Interest
 C The distribution of operations
 D Missions of higher, lower, or adjacent units
 E Unit contingency plans in place or in development
 F FR capabilities related to current or future ops
 G EN capabilities related to current or future ops

SAMPLE CLARITY DEFICIENCIES
 A Poorly organized
 B Too much jargon
 C Too detailed
 D Too general
 E Too long
 F Too many acronyms
 G Too technical
 H Too abbreviated
 I Emphasis in wrong area
 J Critical level inappropriate for recipient
 K Inappropriate presentation mode

SAMPLE COMPLETENESS DEFICIENCIES
 METE: SALUTE: S.W.U.H.
 A Mission G Site M Who
 B Enemy H Ability N What
 C Terrain I Location O Where
 D Weather J Unit P When
 E Troops K Time Q Why
 F Time available L Equipment R How

Figure 6. Part 1 of the Performance Rating Form

2. Rate Timeliness.

Each information item is rated on timeliness by determining which scale value, 1 through 5, represents how well that information item was provided. Starting with the first item on the Performance Rating Form, weather situation, the scale value selected is placed in the column "timeliness rating". Each item on the list is rated for timeliness until all the items have been rated. If any of the items were not received, give a scale value of 5 and draw a line across the page in the row for those items. If not received, an item cannot be rated on the other dimensions.

NOTE: An information item may have been received more than once during the rating period. The procedure requires a rating for the information item in general. Thus, it is left up to the observer-participant to determine a final judgment for a composite of items.

EXAMPLE Figure 9 is an example of the second page of the Performance Rating Form completed for the timeliness rating. Note there were four items not received. They were given ratings of 5 and cannot be assessed on the other dimensions. In addition, three items were rated as having been received too late for any action to be taken, e.g. given ratings of 4. Two items were given 3 ratings because they were received in time to take action, but the observer-participant had to rush and use extra resources to accomplish the desired follow-up action. All the other items were received in time to take the appropriate action.

3. Rate Frequency.

After all the items have been rated for timeliness, they are rated for frequency. The rating is done in the same manner. Each information item is rated on frequency by determining the scale value, 1 through 5, which represents how well the item was provided. Starting with the first item on the Performance Rating Form, the scale value selected is placed in the column "frequency rating." The same procedure is carried out for all the remaining items, except those that were rated 5 for timeliness.

Performance Rating Form

(part 2 of 2)

NAME	Frequency Rating (1-5)	Operational Perspective Rating (1-5)	Clarity Rating (1-5)	Completeness Rating (1-5)
POSITION				
DATE				
Enumerate Possible ECOAGs				
Mission	1			
Objectives	1			
Forces	3			
Terrain considerations	3			
Echelonment	5			
Main/supporting efforts	1			
Fires (including air support)	1			
Time/distance factors	5			
Threat advance	1			
Probability	1			
Analysis of Probable ECOAGs				
Enemy strengths	4			
EN Vulnerabilities	4			
Friendly high value targets	5			
Enemy intentions	4			
EN RECCE/Intelligence				
EN RECCE/Intelligence capabilities				
Recent Intel activities/indicators				
Effects of EN Intel on FR operations				
EN Radio Electronic Combat				
REC capabilities				
Recent & significant REC activities				
Effects of REC on FR operations				
EN Special Operations				
EN special ops capabilities				
Recent/significant special ops activities				
Effects of EN special ops on FR ops				
Friendly Vulnerabilities				
Friendly high value targets				
Effects of vulnerabilities on FR operations				
Decoction				
Decoction capabilities				
Recent & significant decoction activities				
Effects of decoction on FR operations				

OPERATIONS SECURITY

ENEMY COURSES OF ACTION

OPERATIONAL PERSPECTIVE DEFICIENCIES

NOT RELATED TO:

A Area of Operations
 B Area of Interest
 C Through/around/beyond of operation
 D Missions of higher, lower, or adjacent units
 E Unit contingency plans in place or in development
 F FR capabilities related to current or future ops
 G EN capabilities related to current or future ops

OPERATIONAL PERSPECTIVE RATINGS

Check one

1 Not applicable provided

2 Easy to understand with comparison

3 Understandable with identification

4 Required extensive identification in order to understand

5 Not understandable

CLARITY RATINGS

Check one

1 No gaps

2 Some gaps though explained

3 Some gaps with no explanation

4 Many gaps with no explanation

5 Too many gaps to see

COMPLETENESS RATINGS

Check one

1 No gaps

2 Some gaps though explained

3 Some gaps with no explanation

4 Many gaps with no explanation

5 Too many gaps to see

TIMELESSNESS RATINGS

Check one

1 Finished in single step

2 Finished, but to reach

3 Finished, required extra resources

4 Finished too late

5 Did not finish

FREQUENCY RATINGS

Check one

1 Other enough

2 Too often but manageable

3 Too often and disruptive

4 Not often enough

5 Did not occur

OPERATIONAL PERSPECTIVE DEFICIENCIES

NOT RELATED TO:

A Area of Operations
 B Area of Interest
 C Through/around/beyond of operation
 D Missions of higher, lower, or adjacent units
 E Unit contingency plans in place or in development
 F FR capabilities related to current or future ops
 G EN capabilities related to current or future ops

OPERATIONAL PERSPECTIVE RATINGS

Check one

1 Not applicable provided

2 Easy to understand with comparison

3 Understandable with identification

4 Required extensive identification in order to understand

5 Not understandable

CLARITY RATINGS

Check one

1 No gaps

2 Some gaps though explained

3 Some gaps with no explanation

4 Many gaps with no explanation

5 Too many gaps to see

COMPLETENESS RATINGS

Check one

1 No gaps

2 Some gaps though explained

3 Some gaps with no explanation

4 Many gaps with no explanation

5 Too many gaps to see

Figure 8. The Performance Rating Form completed for timeliness

EXAMPLE Frequency ratings have been added to the previous example (Figure 10). The ratings indicate that four items, rated 4, were not received often enough, and one item, rated 2, came too often, but was not disruptive. The rest were received often enough.

4. Rate Operational Perspective.

The procedure for rating operational perspective is done in the same manner as the timeliness and frequency ratings. However, in addition to the scale value being placed in the column "operational perspective--rating," the observer-participant needs to describe the deficiency. Sample deficiencies are listed on the Performance Rating Form. The deficiencies A through G, are examples of aspects of the information which would result in an observer participant being unsure as to why the information was received. For example, if the information did not relate to either the area of operations or the area of interest, it would lack operational perspective.

If one of the sample deficiencies describes the deficiency in the item, the letter from the sample list is put in the column "operational perspective--deficiencies." If the deficiency in the item is not in the sample list, an abbreviated description of the deficiency should be written in the column.

EXAMPLE The previous example is further expanded to include operational perspective (Figure 11). One item is a 4 in that it didn't relate to current or future operations. The remaining items were rated either 2 or 3. Two of the items were deficient in "area of interest." (Item B from the sample Operational Perspective Deficiencies List). Although not shown in this example, an item may have more than one deficiency, thus more than one letter per item can be put in the deficiency column.

5. Rate Clarity.

The procedure for rating clarity is the same as that used to rate operational perspective. Scale ratings are selected and placed in the appropriate column for each item. Deficiencies are identified by either a letter from the sample deficiency list or writing in the deficiency. An item may have more than one clarity deficiency.

Performance Rating Form

(part 2 of 2)

NAME	POSITION	DATE	Enumerate Possible ECOAs	Timeliness Rating (1-5)	Frequency Rating (1-5)	Operational Perspective Rating (1-5)	Clarity Rating (1-5)	Completeness Rating (1-5)
			Mission	1	1			
			Obstacles	1	1			
			Forces	3	1			
			Terrain considerations	3	1			
			Echolocation	5	1			
			Main/supporting efforts	1	4			
			Fires (including air support)	1	4			
			Time/distance factors	5	1			
			Threat advance	5	1			
			Probability	1	1			
			Analysis of Probable ECOAs					
			Enemy strengths	4	1			
			EN Vulnerabilities	4	4			
			Friendly high value targets	5	1			
			Enemy Intentions	4	4			
			EN RECCE/Intelligence	4	4			
			EN RECCE/Intelligence capabilities	1	1			
			Recent Intel activities/indicators	1	1			
			Effects of EN Intel on FR operations	1	2			
			EN Radio Electronic Combat					
			REC capabilities	1	1			
			Recent & significant REC activities	1	1			
			Effects of REC on FR operations	1	1			
			EN Special Operations	1	1			
			EN special ops capabilities	1	1			
			Recent/significant special ops activities	1	1			
			Effects of EN special ops on FR ops	1	1			
			Friendly Vulnerabilities	1	1			
			Friendly high value targets	1	1			
			Effects of vulnerabilities on FR operations	1	1			
			Decapitation	1	1			
			Decapitation capabilities	1	1			
			Recent & significant decapitation activities	1	1			
			Effects of decapitation on FR operations	1	1			

OPERATIONS SECURITY

OPERATIONAL PERSPECTIVE DEFICIENCIES

NOT RELATED TO:

A Area of Operations
 B Area of Interest
 C Threatening/defense of operation
 D Missions of higher, lower, or adjacent units
 E Unit configuration plans in place at development
 F FR capabilities related to current or future ops
 G EN capabilities related to current or future ops

OPERATIONAL PERSPECTIVE DEFICIENCIES

NOT RELATED TO:

A Area of Operations
 B Area of Interest
 C Threatening/defense of operation
 D Missions of higher, lower, or adjacent units
 E Unit configuration plans in place at development
 F FR capabilities related to current or future ops
 G EN capabilities related to current or future ops

CLARITY RATINGS

Benchmark Rating

Check one

1 Very different perspective
 2 Relates to key aspects of commander's ops
 3 Speaks to some aspects of commander's ops
 4 Does not relate to commander's ops
 5 No perspective provided

CLARITY RATINGS

Benchmark Rating

Check one

1 Easy to understand
 2 Easy to understand with comparison
 3 Understandable with brief identification
 4 Required extensive identification to understand
 5 Not understandable

COMPLETENESS RATINGS

Benchmark Rating

Check one

1 No gaps
 2 Some gaps through explanation
 3 Some gaps with no explanation
 4 Many gaps with no explanation
 5 Too many gaps to use

CLARITY RATINGS

Benchmark Rating

Check one

1 No gaps
 2 Some gaps through explanation
 3 Some gaps with no explanation
 4 Many gaps with no explanation
 5 Too many gaps to use

COMPLETENESS DEFICIENCIES

WELL

SALUTE

W Who
 S Site
 A Activity
 M Method
 T Terrain
 L Location
 U Unit
 T Troops
 T Time available
 L Equipment
 R How

Figure 10. Performance Rating Form with the Frequency Dimension completed.

Performance Rating Form

(part 2 of 2)

NAME	POSITION	DATE	Enumerate Possible ECOAs	Timeliness Rating (1-5)	Frequency Rating (1-5)	Operational Perspective Rating (1-5)	Clarity Deficiencies Rating (1-5)	Completeness Rating Deficiencies (1-5)
			Mission	1	1	2		
			Objectives	1	1	2		
			Forces	3	1	2		
			Terrain considerations	3	1	2		
			Echelonment	5				
			Main/supporting efforts	1	4	3	B	
			Fires (including air support)	1	4	2		
			Time/distance factors	5				
			Threat advance	1	1	2		
			Probability	1				
			Analysis of Probable ECOAs	4	1	2		
			Enemy strengths	4	4	2		
			EN Vulnerabilities	5				
			Friendly high value targets	4	4	4	B	
			Enemy intentions	4	4	4		
			EN RECCE/Intelligence	1	1	3		
			EN RECCE/Intelligence capabilities	1	1	3		
			Recent Intel activities/indicators	1	2	3		
			Effects of EN Intel on FR operations	1				
			EN Radio Electronic Combat	1				
			REC capabilities	1	1	3		
			Recent & significant REC activities	1	1	3		
			Effects of REC on FR operations	1	1	3		
			EN Special Ops capabilities	1	1	3		
			EN special ops capabilities	1	1	3		
			Recent/significant special ops activities	1	1	3		
			Effects of EN special ops on FR ops	1	1	3		
			Friendly Vulnerabilities	1	1	3		
			Friendly high value targets	1	1	3		
			Effects of vulnerabilities on FR operations	1	1	3		
			Deception	1	1	3		
			Deception capabilities	1	1	3		
			Recent & significant deception activities	1	1	3		
			Effects of deception on FR operations	1	1	3		

OPERATIONS SECURITY

ENEMY COURSES OF ACTION

OPERATIONAL PERSPECTIVE DEFICIENCIES

NOT RELATED TO:

A Area of Operations
 B Area of Interest
 C Time/synchronization of operation
 D Location of higher, lower, or adjacent units
 E Unit contingency plans in place or in development
 F FR capabilities related to current or future ops
 G EN capabilities related to current or future ops

OPERATIONAL PERSPECTIVE DEFICIENCIES

NOT RELATED TO:

A Area of Operations
 B Area of Interest
 C Time/synchronization of operation
 D Location of higher, lower, or adjacent units
 E Unit contingency plans in place or in development
 F FR capabilities related to current or future ops
 G EN capabilities related to current or future ops

OPERATIONAL PERSPECTIVE RATINGS

Check one: 1 No perspective provided
 2 Perspective provided

CLARITY RATINGS

Check one: 1 Easy to understand
 2 Easy to understand with completion
 3 Understandable with immediate clarification
 4 Required extensive immediate clarification to understand
 5 Not understandable

COMPLETENESS RATINGS

Check one: 1 No gaps
 2 Some gaps though explained
 3 Some gaps with no explanation
 4 Many gaps with no explanations
 5 Too many gaps to see

OPERATIONAL PERSPECTIVE RATINGS

Check one: 1 Did not receive
 2 Too often not recognizable
 3 Too often and disruptive
 4 Not often enough
 5 Did not receive

OPERATIONAL PERSPECTIVE DEFICIENCIES

NOT RELATED TO:

A Area of Operations
 B Area of Interest
 C Time/synchronization of operation
 D Location of higher, lower, or adjacent units
 E Unit contingency plans in place or in development
 F FR capabilities related to current or future ops
 G EN capabilities related to current or future ops

OPERATIONAL PERSPECTIVE RATINGS

Check one: 1 Did not receive
 2 Too often not recognizable
 3 Too often and disruptive
 4 Not often enough
 5 Did not receive

CLARITY RATINGS

Check one: 1 Easy to understand
 2 Easy to understand with completion
 3 Understandable with immediate clarification
 4 Required extensive immediate clarification to understand
 5 Not understandable

COMPLETENESS RATINGS

Check one: 1 No gaps
 2 Some gaps though explained
 3 Some gaps with no explanation
 4 Many gaps with no explanations
 5 Too many gaps to see

OPERATIONAL PERSPECTIVE DEFICIENCIES

NOT RELATED TO:

A Area of Operations
 B Area of Interest
 C Time/synchronization of operation
 D Location of higher, lower, or adjacent units
 E Unit contingency plans in place or in development
 F FR capabilities related to current or future ops
 G EN capabilities related to current or future ops

OPERATIONAL PERSPECTIVE RATINGS

Check one: 1 Did not receive
 2 Too often not recognizable
 3 Too often and disruptive
 4 Not often enough
 5 Did not receive

CLARITY RATINGS

Check one: 1 Easy to understand
 2 Easy to understand with completion
 3 Understandable with immediate clarification
 4 Required extensive immediate clarification to understand
 5 Not understandable

COMPLETENESS RATINGS

Check one: 1 No gaps
 2 Some gaps though explained
 3 Some gaps with no explanation
 4 Many gaps with no explanations
 5 Too many gaps to see

OPERATIONAL PERSPECTIVE DEFICIENCIES

NOT RELATED TO:

A Area of Operations
 B Area of Interest
 C Time/synchronization of operation
 D Location of higher, lower, or adjacent units
 E Unit contingency plans in place or in development
 F FR capabilities related to current or future ops
 G EN capabilities related to current or future ops

OPERATIONAL PERSPECTIVE RATINGS

Check one: 1 Did not receive
 2 Too often not recognizable
 3 Too often and disruptive
 4 Not often enough
 5 Did not receive

CLARITY RATINGS

Check one: 1 Easy to understand
 2 Easy to understand with completion
 3 Understandable with immediate clarification
 4 Required extensive immediate clarification to understand
 5 Not understandable

COMPLETENESS RATINGS

Check one: 1 No gaps
 2 Some gaps though explained
 3 Some gaps with no explanation
 4 Many gaps with no explanations
 5 Too many gaps to see

OPERATIONAL PERSPECTIVE DEFICIENCIES

NOT RELATED TO:

A Area of Operations
 B Area of Interest
 C Time/synchronization of operation
 D Location of higher, lower, or adjacent units
 E Unit contingency plans in place or in development
 F FR capabilities related to current or future ops
 G EN capabilities related to current or future ops

OPERATIONAL PERSPECTIVE RATINGS

Check one: 1 Did not receive
 2 Too often not recognizable
 3 Too often and disruptive
 4 Not often enough
 5 Did not receive

CLARITY RATINGS

Check one: 1 Easy to understand
 2 Easy to understand with completion
 3 Understandable with immediate clarification
 4 Required extensive immediate clarification to understand
 5 Not understandable

COMPLETENESS RATINGS

Check one: 1 No gaps
 2 Some gaps though explained
 3 Some gaps with no explanation
 4 Many gaps with no explanations
 5 Too many gaps to see

Figure 11 Performance Rating Form with Operational Perspective rated.

EXAMPLE

The previous example is expanded to include clarity (Figure 12). Eight of the items had deficiencies. Three had only 1, three had 2 and the rest had 3 deficiencies. Deficiency A "poorly organized" was the most frequent deficiency.

6. Rate Completeness and Reestablish Benchmarks.

Completeness is rated in the manner as clarity. Both scale values and the letter representing the deficiency are placed in the appropriate column for each item. As before, an item may have more than one deficiency. When you have completed the rating, be sure the benchmarks for each dimension have been identified.

EXAMPLE

The example is now complete (Figure 13). All of the items have been rated for each of the five dimensions and the deficiencies, where appropriate, have been identified.

NOTE THAT THE BENCHMARKS FOR EACH DIMENSION ARE IDENTIFIED.

7. Quality Control.

After the Performance Rating Form has been completed, it should be reviewed to make sure all the items have been rated and the deficiencies identified. The form should be turned in to the team chief according to the procedure determined in the training meeting. Although the observer-participants have previously established their benchmarks, they should reestablish them for each of the dimensions for each rating period, by marking the appropriate boxes in the left column.

D. ADMINISTRATIVE CONSIDERATIONS.

The ratings take time, but because of their importance to the assessment, they must be accomplished. The ratings must also be passed to the team chief and diagnostician so that timely diagnostics and feedback can be given. It is the responsibility of the observer-participant to do what is necessary to accomplish the ratings. One hour should be enough to complete the ratings, although the time it takes will vary depending on the amount of information received, the number of deficiencies, and the experience of the observer-participant in doing the ratings.

The procedure outlined above represents one found to be fast and effective. If the observer-participant develops a different procedure which is comfortable to him, that is acceptable. The primary requirements are accurate and complete ratings.

Performance Rating Form

(part 2 of 2)

NAME	Position	DATE	Enumerate Possible ECOAs	Timeliness Rating (1-5)	Frequency Rating (1-5)	Operational Perspective Rating (1-5)	Clarity Rating (1-5)	Completeness Rating (1-5)
			Mission	1	1	2	3	
			Objectives	1	1	2	2	
			Forces	3	1	2	3	
			Terrain considerations	3	1	2	1	
			Echelonment	5				
			Main/supporting efforts	1	4	3	4	A B E
			Fires (including air support)	1	4	2	4	A E I
			Time/distance factors	5				
			Threat advance	5				
			Probability	1	1	2	5	J
			Analysis of Probable ECOAs					
			Enemy strengths	4	1	2	3	A D
			EN Vulnerabilities	4	4	2	3	A D
			Friendly high value targets	5				
			Enemy intentions	4	4	4	3	A D
			EN RECCE/Intelligence					
			EN RECCE/Intelligence capabilities	1	1	3	1	
			Recent Intel activities/indicators	1	1	2	1	
			Effects of EN intel on FR operations	1	2	3	1	
			EN Radio Electronic Combat					
			REC capabilities	1	1	3	1	
			Recent & significant REC activities	1	1	3	1	
			Effects of REC on FR operations	1	1	3	1	
			EN Special Operations					
			EN special ops capabilities	1	1	3	1	
			Recent/significant special ops activities	1	1	3	1	
			Effects of EN special ops on FR ops	1	1	3	1	
			Friendly Vulnerabilities					
			Friendly high value targets	1	1	3	1	
			Effects of vulnerabilities on FR operations	1	1	3	1	
			Deception					
			Deception capabilities	1	1	3	1	
			Recent & significant deception activities	1	1	3	1	
			Effects of deception on FR operations	1	1	3	1	

TIMELINESS RATINGS
 Check one
 1 Received in ample time
 2 Received, but to such
 3 Received, required some rework
 4 Received too late
 5 Did not receive

FREQUENCY RATINGS
 Check one
 1 Often enough
 2 Too often but manageable
 3 Too often and disruptive
 4 Not often enough
 5 Did not receive

OPERATIONAL PERSPECTIVE RATINGS
 Check one
 1 None, different perspective
 2 Relates to key aspects of current/future ops
 3 Emphasizes to some aspects of current/future ops
 4 Does not relate to current/future ops
 5 No perspective provided

CLARITY RATINGS
 Check one
 1 Easy to understand
 2 Easy to understand with comparison
 3 Understandable with simplification
 4 Required extensive simplification to understand
 5 Not understandable

COMPLETENESS RATINGS
 Check one
 1 No gaps
 2 Some gaps though explained
 3 Some gaps with no explanation
 4 Many gaps with no explanation
 5 Too many gaps to use

SAMPLE OPERATIONAL PERSPECTIVE DEFICIENCIES
 NOT RELATED TO:
 A Area of Operations
 B Area of Interest
 C Time/sequencing of operations
 D Missions of higher, lower, or adjacent units
 E Unit contingency plans in place or in development
 F FR capabilities related to current or future ops
 G EN capabilities related to current or future ops

SAMPLE CLARITY DEFICIENCIES
 A Poorly organized G Too technical
 B Too much jargon H Too abbreviated
 C Too detailed I Emphasis in wrong areas
 D Too general J Content level inappropriate for recipient
 E Too long
 F Too many acronyms K Inappropriate presentation media

SAMPLE COMPLETENESS DEFICIENCIES
 M Lacking
 N Missing
 O Who
 P What
 Q Where
 R When
 S Why
 T How

Figure 12. Performance Rating Form with Clarity Dimension rated.

Performance Rating Form

(part 2 of 2)

TIMELINESS RATINGS

- Check one
- 1 Received in ample time
 - 2 Received, had to rush
 - 3 Received, required extra resources
 - 4 Received too late
 - 5 Did not receive

FREQUENCY RATINGS

- Check one
- 1 Often enough
 - 2 Too often but manageable
 - 3 Too often and disruptive
 - 4 Not often enough
 - 5 Did not receive

OPERATIONAL PERSPECTIVE RATINGS

- Check one
- 1 None, different perspective
 - 2 Focuses on key aspects of contributor's ops
 - 3 Emphasizes same aspects of contributor's ops
 - 4 Does not relate to contributor's ops
 - 5 No perspective provided

CLARITY RATINGS

- Check one
- 1 Easy to understand
 - 2 Easy to understand with comparison
 - 3 Understandable with identification
 - 4 Required extensive identification to understand
 - 5 Not understandable

COMPLETENESS RATINGS

- Check one
- 1 No gaps
 - 2 Some gaps though explained
 - 3 Some gaps with no explanations
 - 4 Many gaps with no explanations
 - 5 Too many gaps to use

SAMPLE OPERATIONAL PERSPECTIVE DEFICIENCIES

- OPERATIONAL PERSPECTIVE NOT RELATED TO:
- A Area of Operations
 - B Area of Interest
 - C Time/Phase/Duration of operation
 - D Mission of higher, lower, or adjacent units
 - E Unit contingency plans in place or in development
 - F FR capabilities related to current or future ops
 - G EN capabilities related to current or future ops

SAMPLE CLARITY DEFICIENCIES

- A Poorly organized
- B Too much jargon
- C Too detailed
- D Too general
- E Too long
- F Too many acronyms
- G Too technical
- H Too abbreviated
- I Emphasis in wrong areas
- J Content level inappropriate for recipient
- K Inappropriate presentation media

SAMPLE COMPLETENESS DEFICIENCIES

- MED-J SALUTE S.W.H.
- A Mission
 - B Enemy
 - C Terrain
 - D Weather
 - E Troops
 - F Time available
 - G Size
 - H Activity
 - I Location
 - J Unit
 - K Time
 - L Equipment
 - M Who
 - N What
 - O Where
 - P When
 - Q Why
 - R How

NAME	POSITION	DATE	Timeliness Rating (1-5)	Frequency Rating (1-5)	Operational Perspective Rating (1-5)	Clarify Rating (1-5)	Completeness Rating (1-5)
ENEMY COURSES OF ACTION							
Enumerate Possible ECOAs							
Mission			1	1		3	2
Objectives			1	1		2	2
Focuses			3	1		3	2
Terrain considerations			3	1		1	2
Echelonment			5				
Main/supporting efforts			1	4	B	4	2
Fires (including air support)			1	4		4	2
Time/distance factors			5				
Threat advance			5				
Probability			1	1		1	2
Analysis of Probable ECOAs							
Enemy strengths			4	1		3	2
EN Vulnerabilities			4	4		3	2
Friendly high value targets			5				
Enemy Intentions			4	4	B	3	2
EN RECCE/Intelligence							
EN RECCE/Intelligence capabilities			1	1		1	3
Recent Intel activities/indicators			1	1		1	3
Effects of EN Intel on FR operations			1	2		1	3
EN Radio Electronic Combat							
REC capabilities			1	1		1	3
Recent & significant REC activities			1	1		1	3
Effects of REC on FR operations			1	1		1	3
EN Special Operations							
EN special ops capabilities			1	1		1	3
Recent/significant special ops activities			1	1		1	3
Effects of EN special ops on FR ops			1	1		1	3
Friendly Vulnerabilities							
Friendly high value targets			1	1		1	3
Effects of vulnerabilities on FR operations			1	1		1	3
Deception							
Deception capabilities			1	1		1	3
Recent & significant deception activities			1	1		1	3
Effects of deception on FR operations			1	1		1	3
OPERATIONS SECURITY							

Figure 13. A completed Performance Rating Form

Depending on the objectives and the extent of the exercise, it may not be necessary for the observer-participants to rate all the items. There are other options.

Rating only deficient items. This is the fastest and easiest option. The observer-participant rates only those items that were deficient. The rating can occur when the deficiency is noted, or within the agreed upon time window. While an acceptable method for assessment purposes, it does not provide data on what is being done well.

Rating only the most important information items. When this is done the weights for the most important items must be recorded on the rating form. Again, ratings can be done as deficiencies occur or during the time window. While this method is also satisfactory, it reduces the amount of data for feedback to the G2 and commander.

Rating both important information items and deficient items. This is a combination of the above. Once again, this method offers less feedback data than the suggested method.

The seriousness of the consequences of not rating all the information items must be considered. While the options permit diagnosis, they severely limit the feedback that can be given the commander and G2. In the case of rating deficient items only, the feedback can only be negative since there will be no data on the non-rated items. In the other cases, it will be difficult to track improvement in performance except for a limited number of items. As a result, the entire picture may not be presented. Potential problems may be overlooked and preventive action not taken. It is strongly recommended that the complete assessment method be implemented.

Rating all the items, while time consuming, gives a full picture for both diagnosis and feedback.

E. SUMMARY.

The steps necessary to rate the effectiveness of Military Intelligence information production are as follows:

1. Review scales and definitions for the scales.
2. Rate all information items using the timeliness scale.
3. Rate all information items using the frequency scale.

4. Rate all information items using the operational perspective scale and the sample operational perspective deficiencies.
5. Rate all information items using the clarity scale and the sample clarity deficiencies.
6. Rate all information items using the completeness scale and the sample completeness deficiencies.
7. Reestablish the benchmarks.
8. Review the ratings for completeness and turn in to the team chief.

F. IMPORTANCE OF THE RATING.

The ratings from the observer-participants are the basis of the diagnostic plan which is used to determine the cause of the deficiencies in the intelligence. The ratings also provide the basis for the feedback to the commander and G2. Thus, they are the backbone of the assessment procedure. Because of their importance, the ratings must be as accurate and as comprehensive as possible.

SECTION 6

DIAGNOSING MILITARY INTELLIGENCE PERFORMANCE ANALYZING THE RATINGS

While the ratings provided by observer-participants form the basis for conducting an assessment, common sense and an understanding of what the unit is trying to achieve are the critical elements of a successful diagnosis. There are two phases of the diagnosis. The first phase, the analysis, includes combining the rating from data provided by the different observer-participants and analyzing the combined deficiency data. The second phase, the inquiry, involves developing an inquiry strategy for conducting the diagnosis, the actual gathering of data, data analysis, and recording of the findings.

A. DEFICIENCY CONSOLIDATION WORKSHEET.

The analysis of the observer-participant ratings must be done rapidly so that diagnosis can be carried out during the exercise. The Deficiency Consolidation Worksheet provides a means to rapidly record data from the various rating forms to produce a visual display of how the deficiencies cluster.

B. DESCRIPTION OF THE DEFICIENCY CONSOLIDATION WORKSHEET.

A copy of the worksheet is in Figure 14. Copies are also in Appendix C-1, along with instructions on its use (C-2). There are four different worksheets, one for each of the four major information categories. The worksheets are in the same format. In the left column are the information items for the information category identified at the top of the column. Across the top of the matrix and identifying the remaining columns are the five dimensions the items were rated on. A cell is described in terms of both the vertical and horizontal dimensions. For example, the cell with the A in it will contain data about the "terrain effect on the EN operation" which was deficient on operational perspective.

C. STEP 4, ANALYZING THE RATINGS: CONSOLIDATING THE PERFORMANCE RATING FORM DATA.

A deficient item is one that falls below the observer-participant's benchmark. For example, if the benchmark for operational perspective is 3, any item rated 4 or 5 on operational perspective is deficient according to that observer-participant. Therefore, in order to fill in the worksheet, the benchmark for each dimension for each observer-participant must be known. The benchmarks are in the left column of the Performance Rating Form.

DEFICIENCY CONSOLIDATION WORKSHEET

BATTLEFIELD AREA	Timeliness	Frequency	Oper Perspective	Clarity	Completeness
Weather situation					
Weather effects on EN					
Weather effects on FR					
Terrain situation					
Terrain effects on EN			A		
Terrain effects on FR					
Existing battlefield conditions					
Effects on EN operations					
Effects on FR operations					

Figure 14. A Deficiency Consolidation Worksheet

There are many procedures for filling in the worksheet. The procedure used will depend upon how many observer-participants are involved in the assessment. If there are many, say more than 10, a mechanical data consolidation is necessary. If there are fewer, the diagnostician might be able to consolidate just by looking over the Performance Rating Forms.

The method suggested and illustrated is when there are many observer-participants. However, the diagnostician should use whatever procedure he is most comfortable with for the amount of data that must be consolidated.

D. SUGGESTED PROCEDURE FOR COMPLETING THE WORKSHEET.

1. On each Performance Rating Form, circle the deficient ratings. For example, if the benchmark for timeliness is 3, circle all the 4s and 5s in the timeliness column. If the benchmark for frequency is 2, circle all the 3s, 4s, and 5s in the frequency column. Do the same for the other dimensions.
2. When all the rating forms have been completed, place the deficient items in the appropriate cell of the consolidation worksheet. Place a line across the circled number on the rating form as the data is recorded. This should prevent recording the same data more than once.
3. Record in the appropriate cell of the consolidation worksheet the position that did the rating, for example G2 OPS. For the timeliness dimension, also indicate if the item was not received. When the deficient items from an observer-participant have been recorded, a check should be placed at the top of the rating form to indicate the data has been recorded.
4. Record the deficiencies for all the rating forms.

EXAMPLE

The example uses a rating form for one observer-participant (Figure 15) and shows one of the four completed worksheets for that observer-participant (Figure 16). The example illustrates how the data from the rating form fell into the different cells of the consolidation worksheet. It shows that there are 15 deficiencies. Note that there are information items on the Performance Rating Form which have letters in the deficiency column, but don't have circled ratings. While that item may

Performance Rating Form

(part 2 of 2)

NAME	POSITION	DATE	Timeliness Rating (1-5)	Frequency Rating (1-5)	Operational Perspective Rating (1-5)	Clarity Rating (1-5)	Completeness Rating (1-5)
ENEMY COURSES OF ACTION							
Enumerate Possible ECOAs							
Mission			1	1		3	2
Objectives			1	1		2	2
Forces			3	1		3	2
Terrain considerations			3	1		1	2
Echelonment			5	1			
Main/supporting efforts			1	4	B	A B E	2
Fires (including air support)			1	4		A	2
Time/distance factors			4	1			
Threat advance			4	1		J	2
Probability			1	1			
Analysis of Probable ECOAs							
Enemy strengths			4	1		2	3
EN Vulnerabilities			4	1		3	3
Friendly high value targets			4	1			
Enemy intentions			4	1	B	3	3
EN RECOE/Intelligence							
EN RECOE/Intelligence capabilities			1	1		1	1
Recent Intel activities/Indicators			1	1		1	3
Effects of EN Intel on FR operations			1	2		1	3
EN Radio Electronic Combat							
REC capabilities			1	1		1	1
Recent & significant REC activities			1	1		1	3
Effects of REC on FR operations			1	1		1	3
EN Special Operations							
EN special ops capabilities			1	1		1	3
Recent/significant special ops activities			1	1		1	3
Effects of EN special ops on FR ops			1	1		1	3
Friendly Vulnerabilities							
Friendly high value targets			1	1		1	3
Effects of vulnerabilities on FR operations			1	1		1	3
Deception							
Deception capabilities			1	1		1	3
Recent & significant deception activities			1	1		1	3
Effects of deception on FR operations			1	1		1	3
OPERATIONS SECURITY							

TIMELINESS RATINGS
 Benchmark Rating
 Check one: 1 Reached in ample time
 2 Reached, but to risk
 3 Reached, required extra resources
 4 Reached too late
 5 Did not receive

FREQUENCY RATINGS
 Benchmark Rating
 Check one: 1 Often enough
 2 Too often but manageable
 3 Too often and disruptive
 4 Not often enough
 5 Did not receive

OPERATIONAL PERSPECTIVE RATINGS
 Benchmark Rating
 Check one: 1 None, different perspective
 2 Focuses to key aspects of commander's eye
 3 Focuses to some aspects of commander's eye
 4 Does not relate to commander's eye
 5 No perspective provided

CLARITY RATINGS
 Benchmark Rating
 Check one: 1 Easy to understand
 2 Easy to understand with comparison
 3 Understandable with familiarization
 4 Required extensive familiarization to understand
 5 Not understandable

COMPLETENESS RATINGS
 Benchmark Rating
 Check one: 1 No gaps
 2 Some gaps through explained
 3 Some gaps with no explanations
 4 Many gaps with no explanations
 5 Too many gaps to use

SAMPLE OPERATIONAL PERSPECTIVE DEFICIENCIES
 NOT RELATED TO:
 A Area of Operations
 B Area of Interest
 C Time/Space/Duration of operation
 D Manner of higher, lower, or adjacent units
 E Unit contingency plans in place of its development
 F FR capabilities related to current or future ops
 G EN capabilities related to current or future ops

SAMPLE CLARITY DEFICIENCIES
 A Poorly organized G Too technical
 B Too much jargon H Too abbreviated
 C Too detailed I Emphasis in wrong areas
 D Too general J Content level inappropriate for recipient
 E Too long
 F Too many acronyms K Inappropriate presentation mode

SAMPLE COMPLETENESS DEFICIENCIES
 MET: J SALUTE S.W.H.
 A Mission G Size M Who
 B Enemy H Activity N What
 C Terrain I Location O Where
 D Weather J Unit P When
 E Troops K Time Q Why
 F Time available L Equipment R How

Figure 15. A completed Rating Form for one observer, the G3 Plans Officer

DEFICIENCY CONSOLIDATION WORKSHEET

ENEMY COURSES OF ACTION	Timeliness	Frequency	Oper Perspective	Clarity	Completeness
Mission					
Objectives					
Forces					
Terrain considerations					
Echelonment	G3P-NR				
Main/supporting efforts		G3P		G3P-ABE	
Fires (including air support)		G3P		G3P-AEI	
Time/distance factors	G3P-NR				
Threat advance	G3P-NR				
Probability				G3P-J	
Enemy strengths	G3P				
EN Vulnerabilities	G3P	G3P			
Friendly high value targets	G3P-NR				
Enemy intentions	G3P	G3P	G3P		

Figure 16. Data from Figure 15 recorded on the Deficiency Consolidation Worksheet.

have had a deficiency, the observer-participant still rated it as acceptable.

AN ITEM TO BE DEFICIENT MUST BE RATED BELOW THE BENCHMARK.

The worksheet (Figure 16) shows that the G3 plans identified seven timeliness, four frequency, one operational perspective, and three clarity deficiencies. Note also the short hand for the position, G3P. The short hand is whatever the person filling in the form wants it to be, but anyone who has to use the worksheet later needs to know how to interpret the short hand.

EXAMPLE

Figure 17 shows a Deficiency Consolidation Worksheet completed for five different observer-participants from: FSE, G3 OPS, G3 plans, ADA, and G2 OPS. For example, it shows 13 timeliness deficiencies, 10 because the item was not received (circled and labeled A).

The example represents the consolidation of one rating session having observer-participants for five positions. If there was more than one person rating from the same position, each identifying the same deficiency, then each deficiency must be recorded.

If it is necessary to consolidate the deficiencies over several rating periods, a combined consolidation worksheet can be made. It is done by recording the number of times the item was rated deficient for each position. Thus, an entry, G30-nr(6) in the objectives-timeliness cell would mean that over the course of the exercise that item was rated as not received by the G3 operations on six ratings.

E. STEP 4, ANALYZING THE RATINGS: ANALYZING OF THE DEFICIENCY CONSOLIDATION WORKSHEET.

The worksheet presents a clustering of the deficiencies. From the clustering, the diagnostician can determine deficiencies and their priorities for diagnosing. However, the most important criteria for determining the diagnostic priorities is the objective of the exercise.

DEFICIENCY CONSOLIDATION WORKSHEET

ENEMY COURSES OF ACTION	Timeliness	Frequency	Oper Perspective	Clarity	Completeness
Mission					
Objectives					
Forces					
Terrain considerations					
Echelonment	<u>G3P-NR</u> <u>G30-NR</u> A	G3P		G3P-ABE G30-A	ADA-B
Main/supporting efforts		G3P		G3P-ACE G30-A	
Fires (including air support)				FSE-A	FSE-KI
Timedistance factors	<u>G3P-NR</u> <u>G30-NR</u> A				
Threat advance	<u>G3P-NR</u> <u>G30-NR</u> <u>FSE-NR</u> A			G3P-J G30-A	
Probability				G20-A	
Enemy strengths	G3P				
EN Vulnerabilities	G3P	G3P		G20-A	
Friendly high value targets	<u>G3P-NR</u> <u>G30-NR</u> <u>G30-NR</u> A				
Enemy intentions	<u>G3P</u>	G3P	G3P		

Figure 17. A Deficiency Consolidation Worksheet for 5 observers participants.

EXAMPLES

If the exercise has a limited training objective, such as to train intelligence to rapidly analyze and produce targeting data, the diagnostician may want to focus on deficient items related to enemy unit locations and critical nodes/high payoff targets.

If the training objective is the rapid handling of all intelligence information, the diagnostician may want to concentrate on timeliness deficiencies.

If the assessment environment is a full division exercise where a full range of MI functions are exercised, the diagnostician may prioritize deficiencies based on their potential effect on the outcome of the exercise.

If in doubt, the diagnostician may prioritize based on the assigned weights of the deficient items. A general rule is that it is more important to diagnose items that observer-participants place a high weight on than an item that was assigned a low weight.

F. STEP 5, DETERMINING WHERE DEFICIENCIES OCCUR: INTERPRETING THE WORKSHEET.

Each cell represents a cluster of deficiencies. Reading down the deficiency column indicates how often the specific deficiency occurred. Reading across item row indicates how often that specific item was deficient. Looking within the cells indicates who (the position) was having the problems.

EXAMPLE

An example analyses of the information on the Deficiency Consolidation Worksheet is in Figure 18. There were five observer-participants, one each from: G3 plans, G3 operations, FSE, G2 operations, and ADA. What stands out are the four items, labeled A, that neither the G3 OPS or G3 plans received. Also, timeliness errors predominate (there are 13 deficiencies listed in the timeliness column as opposed to nine in the clarity column). The G3 plans is identifying the most deficiencies (the circled data in the cells), and clarity deficiencies seem to stem from poor organization (note the A by all but one of the deficiencies in the clarity column. The A from the sample deficiency list for clarity was poor organization).

DEFICIENCY CONSOLIDATION WORKSHEET

ENEMY COURSES OF ACTION	Timeliness	Frequency	Oper Perspective	Clarity	Completeness
Mission					
Objectives					
Forces					
Terrain considerations					
Echelonment A	(G3P) NR G30-NR				
Main/supporting efforts		(G3P)		(G3P) - ABE G30 - A	ADA - B
Fires (including air support)		(G3P)		(G3P) - AEI G30 - A	
Time/distance factors A	(G3P) NR G30 - NR			F3E - A	F3E - KI
Threat advance A	(G3P) NR G30 - NR F3E - NR				
Probability				(G3P) J G30 - A	
Enemy strengths	(G3P)			G20 - A	
EN Vulnerabilities	(G3P)	(G3P)		G20 - A	
Friendly high value targets A	(G3P) NR G30 - NR G20 - NR				
Enemy intentions	(G3P)	(G3P)	(G3P)		

Figure 18. Deficiency Consolidation Worksheet

This example is for one of the consolidation worksheets. The worksheets for the other information items would be included in an actual interpretation.

In this example, item weights are not considered. If they were to be considered, a different format for consolidation would have to be used or it would be necessary to concentrate on a particular observer-participant. In the latter case, the information requirements profile would be used along with the Performance Rating Form and worksheet.

SECTION 7

DIAGNOSING MILITARY INTELLIGENCE PERFORMANCE: THE INQUIRY STRATEGY

During this step, the plan for collecting the data necessary to determine the reasons for the deficiencies is laid out. It includes determining where to go to collect the data, determining the questions the diagnostician needs to answer, determining the best way to get the answers, and recording the data after the inquiry.

A. THE PLANNED INQUIRY GUIDE.

The Planned Inquiry Guide is shown in Figure 19. There is another copy in Appendix C-3, along with instructions on its use. The inquiry guide helps to organize the inquiry strategy.

B. DESCRIPTION OF THE PLANNED INQUIRY GUIDE.

The inquiry guide has four vertical columns, "deficiency or areas to diagnose," "potential causes," "where to start," and "questions to be answered." The columns of the guide have been left open to indicate that it may take more than one page to plan the inquiry. How many it takes, or how many deficiencies go on a page depends entirely on the diagnostician, how big he writes, how many deficiencies there are, and how he wants to organize the inquiry.

C. STEP 6, DEVELOP A DIAGNOSTIC PLAN: USING THE INQUIRY GUIDE.

1. Deficiency or Areas to Diagnose.

In the first column, the diagnostician should put the deficiency areas that he wants to diagnose. These were determined from prioritization of information from the Deficiency Consolidation Worksheet.

2. Potential Causes.

Filling in this column is at the discretion of the diagnostician. Because of the experience of the diagnostician, he may have some ideas on why the deficiencies occurred. He may want to note in this column some things to check out.

3. Where to Start.

The inquiry must begin somewhere. The types of deficiencies and the experience of the diagnostician are

PLANNED INQUIRY GUIDE

Deficiency or Areas to Diagnose	Potential Causes	Where to Start	Question Which Must Be Answered

Figure 19. The Planned Inquiry Guide Form

the major factors in defining a place to start seeking answers. The Information Item Deficiency to Source Matrix in Figure 20 and in Appendix C-5, is an aid to determining where to go to begin the inquiry.

Information Item Deficiency to Source Matrix:

In the left column are the major categories of information items. Across the top are the types of deficiencies. Within the cell is the recommended place to begin the inquiry.

EXAMPLE If possible courses of enemy action had not been received, the place to begin inquiry is the all source production section.

If weather information was deficient because of lack of completeness, the place to begin inquiry is G2 operations.

4. Questions Which Must be Answered.

In order to determine why the deficiencies occurred, the diagnostician must find the answers to questions based on the observed information deficiencies. The Diagnostic Question Inventory and its flow charts are aids to help determine the most appropriate questions to ask. The aids, with a complete set of directions on how to use them, are in Appendix C-6, C-7 and C-8. Using the diagnostic question inventory, the diagnostician determines the questions he wants answered. They are recorded in the "questions which must be answered" column of the inquiry guide.

D. DIAGNOSTIC QUESTION INVENTORY.

The question inventory contains sequenced questions, organized by type of deficiency. An example from the inventory is shown in Figure 21. The question inventory should be reviewed to ensure that all the questions, relevant to the particular deficiency being diagnosed, are considered. The question inventory is not comprehensive and only serves as a guide. It may be supplemented by questions or areas of inquiry that experience indicates are important and related to the deficiency.

INFORMATION ITEM DEFICIENCY TO SOURCE MATRIX

Information Item Category	Items Omitted	Poor Quality Items	
	Timeliness/ Frequency	Operational Perspective	Clarity Completeness
BATTELFIELD AREA	G2 Ops	G2	ASPS G2 Ops
Weather	USAF WO	G2	G2 Ops G2 Ops
Terrain	ENG TM	G2	ASPS
Area conditions	ASPS	G2	ASPS
ENSIT	G2 Ops	G2	G2 Ops
Disposition & Comp.	G2 Ops/CM&D	G2	G2 Ops
Strength	G2 Ops/CM&D	G2	G2 Ops
Activities	G2 Ops/CM&D	G2	G2 Ops
ENCOAS	ASPS	G2	ASPS
Possible COAs	ASPS	G2	ASPS
Other Info on Prob. COAs	ASPS/CM&D	G2	ASPS
OPSEC	G2/CI TEAM	G2	G2 Ops
EN Recce/Intel	ASPS/CM&D	G2	ASPS/G2 Ops
EN REC	ASPS/CM&D	G2	ASPS/G2 Ops
EN Special Ops	ASPS/CM&D	G2	ASPS/G2 Ops
FR Vulnerabilities	G2/ASPS	G2	ASPS/G2 Ops
Deception	G2/ASPS	G2	ASPS/G2 Ops

UNIT SPECIFIC COMMENTS:

Figure 20. The Information Item Deficiency to Source Matrix Form.

DEFICIENCY Dimension 1: TIMELINESS

Timeliness is unusual in that if you find a possible cause for a deficiency, correcting it might not provide enough additional time to have prevented the deficiency. You may be dealing with multiple causes, which together contributed to the deficiency. As a result, you will not always stop asking questions when you have discovered a cause. Follow questioning in sequence unless you are to go to a different question.

The first set of questions is to determine whether something went wrong with dissemination. In other words, something got fouled up getting the information out to the observer-participant. Stop asking questions about an information item when you have fully identified what went wrong. Go through each information item on your data sheet. It may become apparent that the same problem is responsible for a deficiency in many items. Use common sense on when to stop asking questions. Item 1a below is a good example, if there are no procedures for prioritizing information, that may affect all deficient items, but that doesn't mean questions 1d and 1e should not be asked since they have nothing to do with prioritization.

Questions 1 and 2 are concerned with the dissemination of information from the MI producer to the user without respect to form; it makes no difference if dissemination is a formal briefing, phone call, or radio transmission.

1. Was information item sent to the user? If no, go to Question 2. If yes, then:
 - a. Was a priority placed on getting the information sent? If no, check to see if there were adequate procedures for prioritizing communications. If there weren't, maybe there should be. If there were, why weren't they followed?
 - b. Did the priority cause other information to be sent first, thus delaying dissemination? If yes, was information prioritized correctly, were procedures followed, or was everything done correctly, but more important information needed to be sent out first?
 - c. Did the person responsible for dissemination respond to the priority? If no, why not? If yes, the problem may be identified by questions 1d or 1e.

Figure 21. Example questions from the diagnostic question inventory on timeliness.

Figure 21. (Cont)

- d. Did the person responsible for dissemination select the best means/alternate means to send the information? If no, look again at procedures to determine if they exist, cover the situation, and were followed.
 - e. Was it confirmed that the user received the information? If no, did procedures exist, did they cover the situation, and were they followed? Could confirmation be carried out?
2. If you identified a possible cause for timeliness deficiency, would correcting it have resulted in enough time being saved to have prevented the deficiency? If yes, have you identified the entire cause?

In addition to the question, the diagnostician should consider how he wants to find the answer. There is considerable flexibility in obtaining answers to the questions. The diagnostician may conduct interviews with individuals in the MI production system, observe procedures and production flow, review documents, or any combination of these. The questions are those the diagnostician must answer. The diagnostician continues answering questions until he determines what could have caused the deficiency.

EXAMPLE A completed Planned Inquiry Guide is shown in Figure 22. Three different deficiencies are addressed. Note that included in the right column is where to go based on the answer to the question. The questions in this column are derived from the Diagnostic Question Inventory in Appendix C. Note also that column 2 reflects the unique unit and situational knowledge of the diagnostician.

E. STEP 7, DIAGNOSING THE INTELLIGENCE INFORMATION PRODUCTION SYSTEM.

Using the Planned Inquiry Guide, the diagnostician moves through the intelligence production system, acquiring data through observation, interviews with intelligence producers, and reviews of documents. The inquiry should result in a series of chained events triggered by responses to the questions started from the Planned Inquiry Guide.

EXAMPLE If the diagnostician is working to determine the cause of an omission deficiency reported by a G3 observer-participant, the inquiry may have begun with a review of the PIR/IR listing in the CM&D. Upon determining through observation that G3 information items were included in the collection plan, the diagnostician must move to other segments of the production system to determine if the information was received, processed, and dispatched to the G3.

While appearing straight forward, the inquiry process is detailed and complex. The diagnostician must be as rigorous as possible given the available time he has to conduct the inquiry.

F. RECORDING THE RESULTS.

Diagnostic Record: Figure 23 is a completed Diagnostic Record. A blank copy is provided in Appendix C-9, along with directions for its use (Appendix C-9). The format parallels the Planned Inquiry Guide. Although the example is for three

PLANNED INQUIRY GUIDE

Deficiency or Areas to Diagnose	Potential Causes	Where to Start	Question Which Must Be Answered
<p>1. Timely submission of HPT info items (FSE).</p> <p>2. Incomplete info item, friendly vulnerability to all users.</p> <p>3. Weather effects info items as sent to ADA deficient in Freq, Ops Per, Clarity, and Comp.</p>	<p>Do we know what FSE wants and in what time?</p> <p>New analyst assigned to OPSEC.</p> <p>Check SOP on ADA reporting Cycle</p>	<p>G2 OPS</p> <p>ASPS</p> <p>SWO</p>	<p>DOI - Timeliness. Was info sent? If yes, stay in G2 Ops and run timeliness section of DOI. If no, go to CM&D and start checking at Question 3.</p> <p>DOI - Completeness. Were missing facts available? If yes, stay in ASPS. If no, go to CM&D and start checking using Question 1, Deficiency Area 5, Completeness.</p> <p>DOI - Frequency. How frequently does user need it? OPS Per la, does Intel have guide to ADA context? Others were facts available.</p>
<p>Additional comments:</p> <p>1. G2OPS really busy past 24 hrs. could be isolated instance of overload. See if Ops asked for help.</p> <p>2. Is new analyst being supervised?</p> <p>3. Big breakdown with ADA. Could use planning session. Determine who knows ADA best.</p>			

Figure 22. A completed Planned Inquiry Guide

DIAGNOSTIC RECORD

Inquiry Data (include location)	Problem(s) Identified	Information Deficiencies	Causes	Recommended Solutions
G2 OPS had no idea of FSE priorities. Info was available.	All Tgt info goes out Ops immediate. Large comm backlog.	FSE High payoff Tgt info in support of attack.	Poor ops relationship with FSE. No updating of priorities. G2 OPS not aware it can get help from ASPS.	Get G2 involved. The whole priorities process needs emphasis.
ASPS/CI Team coordination of OPSEC EEI not being done. Desired info available or can be developed from on hand data.	OPSEC EEI not used in output development.	OPSEC Friendly vulnerabilities.	Failure to develop output which incorporates user needs.	Tighten ASPS/CI team and CMMD dialogue.
SWO/G2 Ops - SWO needs training on Divisions use and need for weather with special attn to ADA.	Standard Wx report form doesn't meet ADA needs. During attack phase frequency of reports inrad.	Wx effect (ADA needs rapid refresh).	SOP is inadequate to meet ADA needs, for sure during offensive ops.	Revise SOP ASAP.
<p>Additional Comments: High Value payoff information is available in great volume. Managing it may require dedicated soldier. New analyst is well supervised and doing a good job. On the ADA matter, in addition to SOP, there is a real need to cross train some intel and ADA people to appreciate each others capabilities.</p>				

Figure 23. A completed Diagnostic Record

deficiencies, how many pages or how many deficiencies should go on a page depends on the amount of information and how the diagnostician organizes it. The form has been left open to provide more space for recording data and making notes when preparing feedback. The purpose of the Diagnostic Record is to help organize the findings. It is a tool to help prepare for giving feedback, not a document that is handed out as part of the feedback.

Inquiry Data: In this column is recorded all the data gathered to support the identification of the cause(s) of the deficiency.

Problems Identified: This column has a description of the problem(s) discovered.

Related Information Deficiency: This column is a restatement of the deficiencies that resulted from the problem.

Causes of Deficiencies: The conclusions drawn from the data in the first column are recorded here. This column indicates why the deficiency occurred.

Recommended Solutions: This column does not have to be filled out. It can be if the diagnostician believes that he may have an acceptable solution. However, it is not the purpose of the diagnosis within this assessment procedure to advise on remedy.

G. ADMINISTRATIVE CONSIDERATIONS.

The planning and conducting of the inquiry into causes of information deficiencies takes time and is done while the exercise is in progress. It must be done with tact and without disruption to the exercise. Because the diagnostics is so time constrained, only the most critical deficiencies should be diagnosed during the exercise.

NOTE: A diagnosis could be done after the exercise, but it would have to be modified some. Procedures couldn't be observed, some of the staff might be difficult to get to to interview, etc.

It cannot be stressed enough that a successful diagnosis is based on the common sense and understanding of the unit of the experienced person conducting the diagnosis.

H. SUMMARY.

The steps in diagnosing Military Intelligence performance are as follows:

1. Consolidate the performance rating data using the Deficiency Consolidation Worksheet.
2. Analyze the consolidation worksheets by identifying clusters of performance deficiencies or deficiencies of high weighted information items.
3. Plan the inquiry strategy using the Planned Inquiry Guide.
4. Gather data to determine the causes for the deficiencies.
5. Record the data and the conclusion based on that data on the Diagnostic Record.

SECTION 8

PROVIDING FEEDBACK

The purpose for conducting the assessment is to provide feedback to the commander and the G2 on how well Military Intelligence met the needs of the command during the designated exercise. While the commander and the G2 should determine how frequently they want to receive feedback, the team chief and diagnostician need to work together to prepare and provide the feedback.

Unless directed by the commander or G2 to only provide specific feedback, the content of the feedback should be determined by when the presentation of the feedback is scheduled. Feedback can be given periodically during the exercise and at the end of the exercise.

FEEDBACK SHOULD ALWAYS BE TO THE G2 AND TO THE COMMANDER FROM THE G2.

A. PERIODIC FEEDBACK DURING THE EXERCISE.

The periodic feedback should not be a presentation of a statistical analysis of the Performance Rating Forms.

Just as the diagnosis was based on common sense and an understanding of the unit, providing feedback during the exercise requires the same traits. Since time is limited for preparing as well as presenting, the feedback should be limited to major findings.

The best source of data for preparing feedback is the Deficiency Consolidation Worksheets which provide clustered information. The most important periodic feedback should concern the deficiencies that the diagnostician selected for inquiry and the findings from the inquiry.

The weights of the information items which were deficient might also be of value in the periodic feedback. This information can be obtained from the observer-participants' Information Requirements Profile (items weighted 100).

Finally, if there has been more than one rating period, or more than one feedback session, changes in performance, either positive or negative will be good feedback. This kind of trend information can be obtained by comparing changes showing up in the consolidation worksheets.

B. POST-EXERCISE FEEDBACK.

The post-exercise feedback must include the information listed above for the periodic feedback. That information is essential. If time is limited, it is the highest priority feedback. The commander and the G2 must at least know what went wrong where and why, so they can implement training or operational fixes. Time permitting, however, the Performance Rating Forms, used in conjunction with the Information Requirements Profile, can provide a wealth of quantitative data. Because there is potentially so much information, it may be necessary to combine it in order to present a structured picture of the assessment results. There are many ways the data can be analyzed, therefore, only a few are presented. The following are some useful techniques for consolidating the data:

Consolidating across deficiency dimensions: Never combine the data for deficiency dimensions: timeliness, frequency, operational perspective, clarity, and completeness should never be combined. Such a consolidation would not be meaningful since important information would be hidden.

Consolidating deficiencies by observer-participants: Very important feedback can be provide by consolidation of data within an observer-participant group. For example, if there are several representatives from the G3 section it is all right to combine their data. It is not acceptable to combine data from the G3 with the FSE. When combining the deficiency data, all that is needed is a total count for certain types of deficiencies. For example, the G3 section for Enemy Courses of Action rated the information item "objective" deficient on 6 occasions during the exercise.

Feedback should be provided in terms of each observer-participant group.

Consolidating across rating periods: This could be done for each observer-participant for any deficiency dimension if it is desired to present a total "score" or a big picture of what happened during the exercise. However, it is best not to present the total "score" alone. It should be presented along with the data for the rating periods, so that the audience has the opportunity to see what makes up the total score and what trends are revealed.

C. ANALYZING THE DEFICIENCY CONSOLIDATION WORKSHEET.

The feedback from the analysis should not be "one measure," but rather a pattern of "measures." There are four measures we propose (details for computing them are in Appendix D):

Comprehensiveness indicates the number of information items which were acceptable. For example, if one item out of the 58 was rated deficient, then 57 would be acceptable. The comprehensiveness score is 98% (57/58 x 100). The higher the percent, the better the performance.

Criticality indicates the importance of the information items which were missed. It is based on the weight given the items by the observer-participant. The higher the number, the worse the performance. For example, if only one item was missed, but it was a 100 weighted item, a critical item was not acceptable.

Effectiveness represents the overall usefulness of the information to the observer-participant. It is based on the number of information items which were not deficient and the weights of the items. It is expressed as a percent. The higher the percent, the better the performance.

Distribution of performance ratings represent how the observer-participant rated each dimension (timeliness, frequency, etc.) on the scale. If a benchmark had been between 3 and 4, for example and the rating showed all 1s, then performance in that dimension would have been as good as it could get.

The four measures can be presented in many different ways. The first three could be shown for the deficiency dimensions combined, or for each deficiency dimension. They could be shown for the exercise, or broken out by rating periods to show trends. The distribution of ratings can be shown for the exercise or broken out by rating periods to show trends.

Trends in Performance as Feedback: Providing the commander and G2 feedback on the trends in MI performance is next in importance to the what, where, why of the deficiencies. The trends place performance in the time perspective of the exercise events. With the trend data, the commander is better able to judge, for example, the impact on intelligence performance of a jump or communications breakdown.

Positive and Negative Feedback: The purpose of having the five point rating scales is to have a means of getting positive information as well as negative. It is critical that positive as well as negative feedback be provided. Often the reasons for doing something well can provide solutions for improving inadequate performance.

Conflicting Data: It would not be unusual to discover that the observer-participant rated information deficient and the diagnostician couldn't find any deficiency in MI information production performance. While it may be difficult to explain the conflicting data, it should at least be brought up for consideration. (If it is important to resolve the conflict, so that direction can be given).

Comparing Performance Across MI Units: The methodology presented for assessing MI information processing effectiveness has one purpose, to assist MI in improving their performance. It is not a grade, nor should it be used as such. Exercises operate with different objectives and under different situational constraints. This requires the assessment results to be interrupted within the constraints of the specific exercise.

APPENDIX A

SUPPLEMENTAL MATERIALS FOR IDENTIFYING AND PRIORITIZING INFORMATION REQUIREMENTS

- A-1 Blank Copy of the Information Requirements Profile
- A-2 Instructions for Weighing the Information Hierarchy
- A-3 Definitions of the Information Items in the Information Hierarchy
- A-4 Timeliness Dimension Scale
- A-5 Frequency Dimension Scale
- A-6 Operational Perspective Dimension Scale
- A-7 Clarity Dimension Scale
- A-8 Completeness Dimension Scale
- A-9 Instructions for Setting Benchmarks

APPENDIX A-1

BLANK COPY OF THE INFORMATION REQUIREMENTS PROFILE

INFORMATION REQUIREMENTS PROFILE

INSTRUCTIONS:

1. Assign zero to any information items you do not want.
2. Assign 100 to your most important information items.
3. Assign a number between 0 and 100 to remaining items to reflect the relative importance of the item.
4. List specific data items you want emphasized under special notes

NAME _____

POSITION _____

DATE _____

	IMPORTANCE WEIGHT (0 - 100)	SPECIAL NOTES
BATTLEFIELD AREA	Weather	
	Weather situation	
	Weather effects on EN	
	Weather effects on FR	
	Terrain	
	Terrain situation	
	Terrain effects on EN	
	Terrain effects on FR	
	Battlefield area conditions	
	Existing battlefield conditions	
Effects on EN operations		
Effects on FR operations		
ENEMY SITUATION	EN Disposition and composition	
	Forward trace	
	Unit locations	
	Main efforts	
	Combat support	
	Echelonment	
	Reserves	
	Staging areas	
	Combat service support	
	Air Forces	
	C2	
	Strength of EN forces by echelon	
	Readiness by echelon	
	Supply status/rates by echelon	
	Enemy critical nodes/HPTs	
	Level of EN morale	
	Strength of Air Forces	
	NBC	
	Recent/present significant activities	
	Combat action	
Maneuver/movement		
C2 activity		
Sustainment		
Intelligence activities		
ENEMY COURSES OF ACTION	Enumerate Possible ECOAs	
	Mission	
	Objectives	
	Forces	
	Terrain considerations	
	Echelonment	
	Main/supporting efforts	
	Fires (including air support)	
	Time/Distance factors	
	Threat advance	
	Probability	
	Analysis of Probable ECOAs	
	Enemy strengths	
	EN Vulnerabilities	
	Friendly high value targets	
Enemy intentions		
OPERATIONS SECURITY	EN RECCE/Intelligence	
	EN RECCE/Intelligence capabilities	
	Recent RECCE/Intelligence activities/indicators	
	Effects of EN intelligence on FR operations	
	EN Radio Electronic Combat	
	REC capabilities	
	Recent & significant REC activities	
	Effects of REC on FR operations	
	EN Special Operations	
	EN special operations capabilities	
	Recent/significant EN special operations	
	Effects of EN special operations on FR operations	
	Friendly Vulnerabilities	
	Friendly high value targets	
	Effects of vulnerabilities on FR operations	
Deception		
Deception capabilities		
Recent/significant deception activities		
Effects of deception on FR operations		

APPENDIX A-2

INSTRUCTIONS FOR WEIGHING THE INFORMATION HIERARCHY

The weighing of the items in the information hierarchy results in the prioritization of your information requirements. A copy of the Information Requirements Profile form and the definitions of elements in the information hierarchy are necessary in order to complete the weighing.

Step 1. Review the information items in the left column and their definitions.

Step 2. Based on the scoring period previously defined, identify the information items that are most important for you to have. Give those items 100 points by placing 100 in the importance weight column in space by that item.

Step 3. If there are any information items you do not need, give them a score of 0 and record in the appropriate space.

NOTE: There is no limit on the number of information items that are most important or are not needed. You may consult the definitions as often as necessary during the weighing.

Step 4. Compare the remaining information items with the ones you have given 100 points. Give each item points based on how important you think it is relative to the 100 point item(s). For example, if "main efforts" was given 100 points and you think "threat advance" is only half as important, give it 50 points. You can give an item anywhere from 0 to 100 points. Record the weights you give for each item in the appropriate space.

Step 5. Make sure that there is a weight for each item.

Step 6. Review the weights and change any weights that you think may not be appropriate. Make sure your name, position, and the date are on the information requirements profile form.

APPENDIX A-3

INFORMATION REQUIREMENTS HIERARCHY DEFINITIONS OF ELEMENTS

Definitions for information items contained in the information requirements hierarchy are presented under their area and group headings. The term information is used instead of intelligence to ensure that all possible output forms are included. While information such as unit locations may be in another broader information area, the hierarchy treats each as a discrete output of intelligence production. Therefore, information items at all levels are mutually exclusive or independent of each other, i.e., do not assume that because "description of enemy courses of action might include "unit locations" is redundant. Remember, all information items are independent.

Level 1: BATTLEFIELD AREA

Specific aspects of the battlefield which includes the unit's area of operation and area of interest, are delineated into three topical groups: weather, terrain, and other battlefield area conditions.

Level 2: WEATHER

Weather in the battlefield is divided into three output subsets of information:

Level 3:

WEATHER SITUATION. Current and projected weather types, including, but not limited to what weather will occur, when, and where.

WEATHER EFFECTS ON EN. How, when, and where current and projected weather types will affect current and projected enemy operations or courses of action.

WEATHER EFFECTS ON FR. How, when, and where current and projected weather types will affect current and projected friendly operations or courses of action.

Level 2: TERRAIN

Battlefield terrain is divided into three output subsets of information:

Level 3:

TERRAIN SITUATION, i.e., elevation, vegetation, mobility, and soil conditions.

TERRAIN EFFECTS ON EN, i.e., degree of slope, vegetation, and soil conditions in the battlefield that will shape enemy operations.

TERRAIN EFFECTS ON FR, i.e., degree of slope, vegetation, and soil conditions in the battlefield that will shape friendly operations.

Level 2: BATTLEFIELD AREA CONDITIONS

Information, other than weather or terrain, pertaining to physical aspects of the battlefield.

Level 3:

EXISTING BATTLEFIELD CONDITIONS. Other physical aspects of the battlefield, excluding weather or terrain as described above, such as avenues of approach, status of lines of communication, or obstacles within the area of operations.

EFFECTS ON EN OPERATIONS. How, when, and where other battlefield conditions will shape the enemy operations.

EFFECTS ON FR OPERATIONS. How, when, and where other battlefield conditions will shape the friendly operations.

Level 1: ENEMY SITUATION

Current, dynamic, and changing enemy situations within the units area of operation and area of interest are delineated into three topical groups: enemy disposition and composition, strength of enemy forces by echelon, and recent and present significant activities.

Level 2: EN DISPOSITION AND COMPOSITION

Organization for combat and current deployment pattern of enemy elements is further subdivided into ten information items:

Level 3:

FORWARD TRACE. Portrayal of actual linear deployment of the most forward enemy forces in contact within the area of operations.

UNIT LOCATIONS. Identifies location using point, center of mass, or area for all enemy units in the area of interest.

MAIN EFFORTS. Enemy tactical efforts in the area of operations in which he has committed significant portions of available combat power, including location, disposition, and composition.

COMBAT SUPPORT. Disposition, composition, and location of enemy combat support elements in the area of interest.

ECHELONMENT. Disposition, composition, subordination, and location of related enemy echelons, i.e., divisions, fronts and armies, in the area of interest.

RESERVES. Disposition, composition, and location of uncommitted enemy combat units in the area of interest.

STAGING AREAS. Information on location of enemy assembly/staging areas, either in use or available, in the area of interest.

COMBAT SERVICE SUPPORT. Disposition, composition, and location of enemy combat service support elements in the area of interest.

AIR FORCES. Disposition, composition, and location of enemy air forces in the area of interest.

C2. Disposition, composition, and location of enemy command and control elements in the area of interest.

Level 2: STRENGTH OF EN FORCES BY ECHELON

Numerical status or combat readiness of enemy units based on attrition in the area of interest, by specific echelons is divided into five information items:

Level 3:

READINESS BY ECHELON. Available combat potential of enemy units in the area of interest.

SUPPLY STATUS/RATES BY ECHELON. Enemy resupply status/rates for items such as fuel or ammunition in the area of interest.

ENEMY CRITICAL NODES/HPT (HIGH PAYOFF TARGETS). Formations, locations, or facilities whose capability, strength, or presence is pivotal to continuation of enemy operations within the area of interest and whose destruction or disruption provides advantage to friendly forces.

LEVEL OF EN MORALE. Morale, well-being, and willingness to fight of enemy units which effects their capability in the area of interest.

STRENGTH OF AIR FORCES. Strength/capability of enemy air forces in the area of interest.

NBC. Strength/capabilities of enemy nuclear, biological, and chemical elements in the area of interest.

Level 2: RECENT/PRESENT SIGNIFICANT ACTIVITIES

Recent (up to 36 hours old) and present significant activities are divided into six information items:

Level 3:

COMBAT ACTION. Enemy combat activities, including but not limited to unusual aspects such as actions involving nuclear, biological, or chemical combat in the area of interest.

C2 ACTIVITY. Enemy command and control activities, i.e., communication activity or command post relocations, in the area of interest.

SUSTAINMENT. Enemy sustainment activities, i.e., resupplying or repairing, in the area of interest.

INTELLIGENCE ACTIVITIES. Enemy intelligence activities, i.e., reconnaissance patrolling, radio intercept, or other covert or overt activities, in the area of interest.

Level 1: ENEMY COURSES OF ACTION

Enemy courses of action (intentions) that are likely or possible are delineated into two topical groups: enumerate possible enemy courses of action and other information for probable enemy courses of action.

Level 2: ENUMERATE POSSIBLE ECOAs

Possible enemy courses of action are divided into the following information items:

Level 3:

MISSION. Probable or known specific tasks/missions of related enemy elements in the area of interest.

OBJECTIVES. Assigned objectives of enemy units, whether force or terrain oriented, in the area of interest.

FORCES. Specific enemy forces related to specific courses of action, including, but not limited to their composition, locations, strength, and disposition.

TERRAIN CONSIDERATIONS. Influence of terrain related to specific enemy courses of action, i.e., routes of advance or crossing sites.

ECHELONMENT. Echelonment or subordination of enemy elements such as battalions, regiment, divisions, or corps to specific courses of action.

MAIN/SUPPORTING EFFORTS. Where, when, and in what strength main and supporting efforts will occur related to specific enemy courses of action.

FIRES (including air support). Where, when, and in what strength fires and types of fires will occur related to specific enemy courses of action.

TIME/DISTANCE FACTORS. Movement in terms of times and distances, i.e., how long it will take for a unit to get from point A to B, related to specific enemy courses of action.

THREAT ADVANCE. How rapidly forces can or will move related to specific enemy courses of action, and influenced by doctrine or terrain.

PROBABILITY. Probability of occurrence for enemy courses of action, i.e., most and least likely COA with rationale, in the area of interest.

Level 2: ANALYSIS OF PROBABLE ECOAs

Probable enemy courses of action are divided into information items:

Level 3:

ENEMY STRENGTHS. Specific aspects of each enemy COA, i.e., force ratios or terrain which are to their advantage.

ENEMY VULNERABILITIES. Specific aspects of each enemy COA, i.e., force ratios or terrain which can make them vulnerable.

FRIENDLY HIGH VALUE TARGETS. Potential friendly high value targets, i.e., friendly units or key terrain held by friendly units that may influence specific enemy courses of action.

ENEMY INTENTIONS. Independent of the assessed probability, information on which courses of action the enemy intends to execute.

Level 1: ENEMY ACTIVITIES AFFECTING OPERATIONS SECURITY

Specialized enemy activities that may influence command operations security posture in both forward and rear battlefield areas are delineated into five topical groups: reconnaissance (RECCE)/intelligence, radio electronic combat (REC), special operations, friendly vulnerabilities, and deception.

Level 2: EN RECCE/INTELLIGENCE

Enemy reconnaissance and intelligence activities that may influence command operations security posture are divided into three information items:

Level 3:

EN RECCE/INTELLIGENCE CAPABILITIES, i.e., imagery or human intelligence that may influence how the friendly command conducts operations.

RECENT RECCE/INTELLIGENCE ACTIVITIES/INDICATORS. Most current and significant enemy intelligence activities and indicators that may influence command operations security posture.

EFFECTS OF EN INTELLIGENCE ON FR OPERATIONS. Effects, as determined either by friendly analysis or enemy information, of enemy RECCE and intelligence activities on our operations.

Level 2: ENEMY RADIO ELECTRONIC COMBAT

Enemy jamming and signals collection activities that may influence the command operations security posture is divided into three information items:

Level 3:

REC CAPABILITIES. Enemy radio and electronic warfare capabilities that may influence how the command conducts operations.

RECENT AND SIGNIFICANT REC ACTIVITIES. Most current and significant enemy radio and electronic warfare activities that may influence how the command conducts operations.

EFFECTS OF REC ON FR OPERATIONS. Effects, determined by either friendly analysis or enemy information, of enemy Radio Electronic Combat activities on friendly operations.

Level 2: EN SPECIAL OPERATIONS

Enemy special operations activities, i.e., special operating forces and espionage/sabotage operations, that may influence command operations security posture is divided into three information items:

Level 3:

ENEMY SPECIAL OPERATIONS CAPABILITIES. Enemy's special operations capabilities, i.e., special operating forces and espionage/sabotage resources, that may influence the command operations security posture.

RECENT/SIGNIFICANT EN SPECIAL OPERATIONS. Enemy's recent special operations, i.e., special operating forces, espionage, or sabotage.

EFFECTS OF EN SPECIAL OPERATIONS ON FR OPERATIONS. Effects, determined either by friendly analysis or enemy information, of enemy special operations on friendly operations.

Level 2: FRIENDLY VULNERABILITIES

Friendly vulnerabilities determined either by the enemy or friendly analysis, that may influence command operations security posture, is divided into two information items:

Level 3:

FRIENDLY HIGH VALUE TARGETS. Friendly vulnerability information, derived from either friendly analysis or enemy information, that concerns our own potentially high value targets.

EFFECTS OF FRIENDLY VULNERABILITIES ON FRIENDLY OPERATIONS. Vulnerability information, derived from friendly analysis or enemy information, that concerns the effects of our vulnerabilities on current or projected operations.

Level 2: DECEPTION

Enemy deception or spoofing activities, that may influence command operations security posture, are divided into three information items:

Level 3:

DECEPTION CAPABILITIES. Present enemy deception capabilities that may influence command operations security posture. These may contain numerous specific data possibilities that need not be further specified.

RECENT/SIGNIFICANT DECEPTION ACTIVITIES. Current and significant enemy deception or spoofing activities that may influence command operations security posture or friendly combat operations.

EFFECTS OF DECEPTION ON FRIENDLY OPERATIONS. Effects, determined by friendly analysis or enemy information, of enemy deception or spoofing activities on our operations.

APPENDIX A-4

TIMELINESS DIMENSION SCALE

TIMELINESS - is a measure of whether the information item was received in time for the user to take action on it. Timeliness applies to situations where there is no stated operational deadline for the information, but a window exists during which the user must take action based on that specific information.

Timeliness Scale:

1. Item received and user had ample time to take operational action within the time window.
2. Item received in time to take action, but user had to rush.
3. Item received in time to take action, but user had to rush and use additional resources.
4. Item received too late for user to take action.
5. Item not received.

APPENDIX A-5

FREQUENCY DIMENSION SCALE

FREQUENCY - is a measure of how often the information item needs to be provided to a user in order for the user to carry out designated routine functions. FREQUENCY involves routine information delivered according to an SOP, by a specified time or in a specified cycle.

Frequency Scale:

1. Item received often enough.
2. Item received more than necessary, but did not disrupt SOP functions.
3. Item received more than necessary and disrupted SOP functions.
4. Item not received often enough.
5. Item not received.

APPENDIX A-6

OPERATIONAL PERSPECTIVE DIMENSION SCALE

OPERATIONAL PERSPECTIVE - is the measure of how well the information item is put in the context of current or future friendly force operations. To contribute to OPERATIONAL PERSPECTIVE, the following context characterizations apply:

- Area of operations
- Area of interest
- Time/Phasing/Duration of the operation
- Missions of higher, lower or adjacent units
- Unit contingency plans in place or in development
- Friendly capabilities related to current or future ops
- Enemy capabilities related to current or future ops

Operational Perspective Scale:

1. Operational perspective identified a new or different perspective on current or future operations.
2. Operational perspective related to key aspects of current or future operations.
3. Operational perspective related to less significant aspects of current or future operations or were limited in scope.
4. Operational perspective did not relate to current or future operations.
5. Item not placed in any operational context.

APPENDIX A-7

CLARITY DIMENSION SCALE

CLARITY - is a measure of how easily the content of the information could be grasped, understood, comprehended or followed by the user, without regard to the presentation format. The following factors detract from the CLARITY of information items:

Poorly organized	Too technical
Too much jargon	Content level inappropriate for recipient
Too detailed	Inappropriate presentation media
Too general	Too abbreviated
Emphasis in wrong areas	Poor use of graphics
Too long	
Too many acronyms	

Clarity Scale:

1. Item easily understood without effort or clarification.
2. Item easily understood with comparison to other information readily available to user.
3. Item understandable with time, effort, and/or clarification.
4. Item took extensive time, effort, and/or clarification to understand.
5. Item not understandable.

APPENDIX A-8

COMPLETENESS DIMENSION SCALE

COMPLETENESS - is a measure of the factual content of the information item as represented by the 5 W's, SALUTE and/or METT-T. The absence of facts does not distract from completeness if the gaps are identified. The following relate to the COMPLETENESS of information:

<u>METT-T</u>	<u>SALUTE</u>	<u>5 W's & H</u>
Mission	Size	Who
Enemy	Activity	What
Terrain (Weather)	Location	Where
Troops	Unit	When
Time Available	Time	Why
	Equipment	How

Completeness Scale:

1. No factual omissions/gaps.
2. Fully-identified and explained factual omissions/gaps.
3. Partially-identified and explained factual omissions/gaps.
4. Unexplained factual omissions/gaps.
5. Information unusable because there were too many unexplained omissions/gaps.

APPENDIX A-9

INSTRUCTIONS FOR SETTING BENCHMARKS

Determining the Benchmarks:

1. For any dimension, review the five levels of performance indicated by the scales.
2. Select the point on the scale that best describes the minimum level of performance which would be acceptable to you.
3. Draw a line under that scale number.
4. Review the items under that line to ensure they describe performance unacceptable to you. If not, redetermine the benchmark.

APPENDIX B

**SUPPLEMENTAL MATERIALS FOR RATING
MILITARY INTELLIGENCE PERFORMANCE**

B-1 Performance Rating Form, Part 1 and 2

B-2 Instructions for Rating Military Intelligence Performance

APPENDIX B-1

PERFORMANCE RATING FORM, PART 1 AND 2

Performance Rating Form

(part 1 of 2)

NAME _____
 POSITION _____
 DATE _____

BATTLEFIELD AREA	Timeliness	Frequency	Operational Perspective	Clarity	Completeness
	Rating (1-5)	Rating (1-5)	Deficiencies	Deficiencies	Rating (1-5) Deficiencies
Weather					
Weather situation					
Weather effects on EN					
Weather effects on FR					
Terrain					
Terrain situation					
Terrain effects on EN					
Terrain effects on FR					
Battlefield Area Conditions					
Existing battlefield conditions					
Effects on EN operations					
Effects on FR operations					
EN Disposition and Composition					
Forward trace					
Unit locations					
Main efforts					
Combat support					
Echelonnement					
Reserves					
Staging areas					
Combat service support					
Air Forces					
G2					
Strength of EN Forces by Echelon					
Readiness by echelon					
Supply status/rates by echelon					
Enemy critical nodes/HPTs					
Level of EN morale					
Strength of Air Forces					
NBC					
Recent/Present Significant Activities					
Combat action					
Maneuver/movement					
C2 activity					
Sustainment					
Intelligence activities					

TIMELINESS RATINGS
 Benchmark Rating
 Check one: 1 Received in ample time
 2 Received, had to rush
 3 Received, required extra resources
 4 Received too late
 5 Did not receive

FREQUENCY RATINGS
 Benchmark Rating
 Check one: 1 Often enough
 2 Too often but manageable
 3 Too often and disruptive
 4 Not often enough
 5 Did not receive

OPERATIONAL PERSPECTIVE RATINGS
 Benchmark Rating
 Check one: 1 None, different perspective
 2 Relates to key aspects of current/ future ops
 3 Relates to some aspects of current/ future ops
 4 Does not relate to current/ future ops
 5 No perspective provided

CLARITY RATINGS
 Benchmark Rating
 Check one: 1 Easy to understand
 2 Easy to understand with comparison
 3 Understandable with identification
 4 Required extensive identification to understand
 5 Not understandable

COMPLETENESS RATINGS
 Benchmark Rating
 Check one: 1 No gaps
 2 Some gaps though explained
 3 Some gaps with no explanation
 4 Many gaps with no explanation
 5 Too many gaps to use

SAMPLE OPERATIONAL PERSPECTIVE DEFICIENCIES
 OPERATIONAL PERSPECTIVE NOT RELATED TO:
 A Area of Operations
 B Area of Interest
 C Time/sequencing of operation
 D Mission of higher, lower, or adjacent units
 E Unit contingency plans in place or in development
 F FR capabilities related to current or future ops
 G EN capabilities related to current or future ops

SAMPLE CLARITY DEFICIENCIES
 A Poorly organized
 B Too much jargon
 C Too detailed
 D Too general
 E Too long
 F Too many acronyms
 G Too technical
 H Too abbreviated
 I Excessive in many areas
 J Constant level inappropriate for recipient
 K Too many acronyms
 L Too poor presentation / media

SAMPLE COMPLETENESS DEFICIENCIES
 MZZLT S/W/H
 A Mission
 B Enemy
 C Terrain
 D Weather
 E Troops
 F Time available
 G Size
 H Ability
 I Location
 J Unit
 K Time
 L Equipment
 M Who
 N What
 O Where
 P When
 Q Why
 R How

Performance Rating Form

(part 2 of 2)

NAME POSITION DATE	Frequency Rating (1-5)	Operational Perspectives Deficiencies Rating (1-5)	Clarity Deficiencies Rating (1-5)	Completeness Rating (1-5)	Compliments Rating (1-5)
ENEMY COURSES OF ACTION					
Enumerate Possible ECOAs					
Mission					
Objectives					
Forces					
Terrain considerations					
Echelonment					
Mean/supporting efforts					
Fires (including air support)					
Time/distance factors					
Threat advance					
Probability					
Analysis of Probable ECOAs					
Enemy strengths					
EN Vulnerabilities					
Friendly high value targets					
Enemy intentions					
EN RECC/Intelligence					
EN RECC/Intelligence capabilities					
Recent Intel activities/indicators					
Effects of EN Intel on FR operations					
EN Radio/Electronic Combat					
REC capabilities					
Recent & significant REC activities					
Effects of REC on FR operations					
EW Special Operations					
EN special ops capabilities					
Recent/significant special ops activities					
Effects of EN special ops on FR ops					
Friendly Vulnerabilities					
Friendly high value targets					
Effects of vulnerabilities on FR operations					
Deception					
Deception capabilities					
Recent & significant deception activities					
Effects of deception on FR operations					
OPERATIONS SECURITY					

TIMELINESS RATINGS

- Check one
- 1 Required to complete time
 - 2 Required, but to rush
 - 3 Required, required extra resources
 - 4 Required for file
 - 5 Not required

FREQUENCY RATINGS

- Check one
- 1 Often enough
 - 2 Too often but acceptable
 - 3 Too often and disruptive
 - 4 Not often enough
 - 5 Not often enough

OPERATIONAL PERSPECTIVE RATINGS

- Check one
- 1 Very different perspective
 - 2 Slightly to key aspects of conventional ops
 - 3 Slightly to some aspects of conventional ops
 - 4 Does not relate to conventional ops
 - 5 No perspective provided

CLARITY RATINGS

- Check one
- 1 Easy to understand
 - 2 Easy to understand with comparison
 - 3 Understandable with further identification
 - 4 Required extensive further identification to understand
 - 5 Not understandable

COMPLETENESS RATINGS

- Check one
- 1 No gaps
 - 2 Some gaps though explainable
 - 3 Some gaps with no explanation
 - 4 Many gaps with no explanation
 - 5 Too many gaps to use

SAMPLE OPERATIONAL PERSPECTIVE DEFICIENCIES

- OPERATIONAL PERSPECTIVE NOT RELATED TO:
- A Area of Operations
 - B Area of Interest
 - C Time/sequencing of operation
 - D Mission of higher, lower, or adjacent units
 - E Unit contingency plans in place or in development
 - F FR capabilities related to current or future ops
 - G EN capabilities related to current or future ops

SAMPLE CLARITY DEFICIENCIES

- A Poorly organized
- B Too much jargon
- C Too detailed
- D Too general
- E Too long
- F Too many acronyms
- G Too technical
- H Too abbreviated
- I Emphasis in wrong areas
- J Content level inappropriate for recipient
- K Inappropriate presentation media

SAMPLE COMPLETENESS DEFICIENCIES

- Check one
- A Mission
 - B Enemy
 - C Terrain
 - D Weather
 - E Troop
 - F Time available
 - G Salute
 - H Who
 - I Ability
 - J Location
 - K Time
 - L Equipment
 - M Who
 - N What
 - O Where
 - P When
 - Q Why
 - R How

APPENDIX B-2

INSTRUCTIONS FOR RATING MILITARY INTELLIGENCE PERFORMANCE

A copy of the Performance Rating Form, part 1 and part 2, and scales and definitions for the five dimensions: timeliness, frequency, operational perspective, clarity, and completeness are required for rating.

- Step 1. Review the scales and the definitions of the scales (Appendix A-4 thru A-8). The definitions should be consulted during the rating, as necessary.
- Step 2. Rate all the information items for timeliness. For each item, place the number of the scale level selected in the "timeliness rating" column in the space next to the information item. For all information items rated 5, not received, draw a line through rest of the spaces in the row, for those items. Those information items cannot be rated on the other dimensions.
- Step 3. Rate all information items for frequency. Place the number of the scale level selected in the "frequency rating" column in the row for the information item.
- Step 4. Rate all information items for operational perspective. Use the same procedures as previously, placing the rating in the appropriate row and column. Where there was a deficiency refer to the sample deficiencies. If the deficiency is described, place the letter for that deficiency in the "operational perspective--deficiencies" column in the row for the deficient item. An item may have more than one deficiency. If the deficiency is not in the sample list, write in the deficiency you observed.
- Step 5. Rate all the information items for clarity using the same procedures as for the other dimensions. Place your rating in the appropriate row and column and identify the deficiencies where necessary.
- Step 6. Rate all the information items for completeness using the same procedures as for the other dimensions. Place your rating in the appropriate row and column and identify the deficiencies where necessary.
- Step 7. Review the rating form to ensure that all items have been rated for each dimension.
- Step 8. Reestablish the benchmark for each dimension.

Step 9. Turn in the ratings according to the previously determined procedure.

APPENDIX C

SUPPLEMENTAL MATERIALS FOR DIAGNOSING MILITARY INTELLIGENCE PERFORMANCE

- C-1 Deficiency Consolidation Worksheets
- C-2 Instructions for the Use of the Deficiency Consolidation Worksheets
- C-3 Planned Inquiry Guide Form
- C-4 Instructions for the Use of the Planned Inquiry Guide
- C-5 Item Deficiency to Source Matrix
- C-6 Instructions for the Use of the Diagnostic Question Inventory and Flow Charts
- C-7 Diagnostic Question Inventory and Flow Chart: Timeliness
- C-8 Diagnostic Question Inventory and Flow Chart: Frequency
- C-9 Diagnostic Question Inventory and Flow Chart: Operational Perspective
- C-10 Diagnostic Question Inventory and Flow Chart: Clarity
- C-11 Diagnostic Question Inventory and Flow Chart: Completeness
- C-12 Diagnostic Record
- C-13 Instructions for the Use of the Diagnostic Record Form

APPENDIX C-1

DEFICIENCY CONSOLIDATION WORKSHEETS

DEFICIENCY CONSOLIDATION WORKSHEET

BATTLEFIELD AREA	Timeliness	Frequency	Oper Perspective	Clarity	Completeness
Weather situation					
Weather effects on EN					
Weather effects on FR					
Terrain situation					
Terrain effects on EN					
Terrain effects on FR					
Existing battlefield conditions					
Effects on EN operations					
Effects on FR operations					

DEFICIENCY CONSOLIDATION WORKSHEET

ENEMY SITUATION	Timeliness	Frequency	Oper Perspective	Clarity	Completeness
Forward trace					
Unit Locations					
Main efforts					
Combat support					
Echelonment					
Reserves					
Staging areas					
Combat service support					
Air Forces					
C2					
Readiness by echelon					
Supply status/rates by echelon					
Enemy critical nodes/HQs					
Level of EN morale					
Strength of Air Forces					
NBC					
Combat Action					
Maneuver/movement					
C2 activity					
Sustainment					
Intelligence activities					

DEFICIENCY CONSOLIDATION WORKSHEET

OPERATIONS SECURITY	Timeliness	Frequency	Oper Perspective	Clarity	Completeness
EN REECE/intelligence capabilities					
Recent intel activities/indicators					
Effects of EN intel on FR operations					
REC capabilities					
Recent & significant REC activities					
Effects of REC on FR operations					
EN special ops capabilities					
Recent/Significant special ops activities					
Effects of EN special ops on FR ops					
Friendly high value targets					
Effects of vulnerabilities on FR operations					
Deception capabilities					
Recent & significant deception activities					
Effects of deception on FR operations					

DEFICIENCY CONSOLIDATION WORKSHEET

ENEMY COURSES OF ACTION	Timeliness	Frequency	Oper Perspective	Clarity	Completeness
Mission					
Objectives					
Forces					
Terrain considerations					
Echelonment					
Main/supporting efforts					
Fires (including air support)					
Time/distance factors					
Threat advance					
Probability					
Enemy strengths					
EN Vulnerabilities					
Friendly high value targets					
Enemy intentions					

APPENDIX C-2

INSTRUCTIONS FOR THE USE OF THE DEFICIENCY CONSOLIDATION WORKSHEET

There are four different worksheets, one for each of the four major information categories, that must be used. This worksheet helps to consolidate data from the observer-participant Performance Ratings Forms. A deficient item is one that falls below the user's benchmark. The following steps are suggested when there are so many Performance Rating Forms to be consolidated that a mechanical procedure is required.

- Step 1. On each Performance Rating Form, circle the deficient ratings for each of the rated dimensions. Complete this step before consolidating the data.
- Step 2. Record in the appropriate cell of the worksheet the user who rated the item deficient. Do this for each of the dimensions. For the timeliness dimension deficiencies, identify when the information item was not received.
- Step 3. Complete step 2 for all observer-participant worksheets. Make some kind of mark on the worksheet as you finish recording the data to ensure the same information is not recorded more than once.

APPENDIX C-3

PLANNED INQUIRY GUIDE FORM

PLANNED INQUIRY GUIDE

Deficiency or Areas to Diagnose	Potential Causes	Where to Start	Question Which Must Be Answered

APPENDIX C-4

INSTRUCTIONS FOR THE USE OF THE PLANNED INQUIRY GUIDE

The Planned Inquiry Guide is used in conjunction with the Deficiency Consolidation Worksheet, the Information Item to Source Matrix, and the Diagnostic Question Inventory and Flow Charts. Its purpose is to systematize and document the diagnostic strategy.

- Step 1. Determine which deficiencies will be diagnosed using the Deficiency Consolidation Worksheet. Record the first deficiency on the worksheet in the "deficiencies or areas to diagnose" column.
- Step 2. If, based on experience, you have any ideas on what the possible cause of the deficiency may be, record them. If not, leave the "potential cause" column blank.
- Step 3. Use the Information Item Deficiency to Source Matrix to determine the best place to begin gathering data. Record the location in the "where to start" column.
- Step 4. Review the Diagnostic Question Inventory and flow charts to select what kind of questions needed to be answered to identify the cause of the deficiency. Record those questions and any others you may want answered in the "questions to answer" column.
- Step 5. Repeat the above steps for each deficiency you intend to diagnose.
- Step 6. When you have finished the planned inquiry, begin collection data.

APPENDIX C-5

ITEM DEFICIENCY TO SOURCE MATRIX

INFORMATION ITEM DEFICIENCY TO SOURCE MATRIX

Information Item Category	Items Omitted	Poor Quality Items	
	Timeliness/ Frequency	Operational Perspective	Clarity Completeness
BATTELFIELD AREA	G2 Ops	G2	ASPS G2 Ops
Weather	USAF WO	G2	G2 Ops G2 Ops
Terrain	ENG TM	G2	ASPS
Area conditions	ASPS	G2	ASPS
ENSIT	G2 Ops	G2	G2 Ops
Disposition & Comp.	G2 Ops/CM&D	G2	G2 Ops
Strength	G2 Ops/CM&D	G2	G2 Ops
Activities	G2 Ops/CM&D	G2	G2 Ops
ENCOAS	ASPS	G2	ASPS
Possible COAs	ASPS	G2	ASPS
Other Info on Prob. COAs	ASPS/CM&D	G2	ASPS
OPSEC	G2/CI TEAM	G2	G2 Ops
EN Recce/Intel	ASPS/CM&D	G2	ASPS/G2 Ops
EN REC	ASPS/CM&D	G2	ASPS/G2 Ops
EN Special Ops	ASPS/CM&D	G2	ASPS/G2 Ops
FR Vulnerabilities	G2/ASPS	G2	ASPS/G2 Ops
Deception	G2/ASPS	G2	ASPS/G2 Ops

UNIT SPECIFIC COMMENTS:

APPENDIX C-6

INSTRUCTIONS FOR THE USE OF THE DIAGNOSTIC QUESTION INVENTORY AND FLOW CHARTS

Both the diagnostic question inventory and the flow charts present a logical way to identify the questions needed to determine the cause(s) of deficiencies in the intelligence information production system. The flow charts provide a rapid view of possible general questions that might be used, and the relationships to other questions which may have to be answered to obtain a complete diagnosis. The Diagnostic Question Inventory presents a more detailed breakdown of the general questions. The general questions, along with their breakdown and the specific information item, can provide some very focused questions for diagnostics.

Diagnostic Question Inventory

The person doing the diagnosis of military intelligence information production must be experienced MI. That background, the diagnostic procedures, and the questions in this inventory will help determine why observer-participants rated some of the information they received as unacceptable.

To determine the cause(s) of the deficiencies, the diagnostician must determine the answers to a series of questions. The inventory provides the diagnostician an aid or guide in determining what questions, in what sequence, he must answer in conducting his inquiry. The inventory is used to assist the diagnostician in filling out column four "questions which must be answered" of the Planned Inquiry Guide.

Organization of the Diagnostic Question Inventory

The inventory is in five sections, each corresponding to one of the dimensions for which an information item could be deficient: timeliness, frequency, operational perspective, clarity, and completeness. There are a set of primary questions with directions on where to find the next set of questions. The directions are based on the answer to the primary question.

There are sets of secondary questions which should be answered in order to identify the cause of the deficiency.

Since the two deficiency areas, frequency and completeness have questions in common, the questions are not repeated for each deficiency area. For example, a primary question for diagnosing completeness may direct you to go to question 3 of

the frequency deficiency diagnosis. That is because, with proper modification, the same questions are relevant to deficiencies in both areas.

Flow Charts for the Diagnostic Question Inventory

For each deficiency area there is a flow chart of the questions in the inventory. The flow charts provide a view of the entire diagnostic questioning for each deficiency dimension. The numbers on the flow charts refer to the questions in the inventory. For example, the number 5b in the timeliness deficiency flow chart refers to the b secondary questions in primary question 5 for the timeliness deficiency dimension. In the case of completeness which has overlapping questions with timeliness, a number with two letters following is direction to go to a different flow chart. For example, 2af in the completeness flow chart means to go to the secondary questions a for question 2 on the frequency flow chart.

On the flow charts for operational perspective, clarity, and completeness are the specific deficiencies which may have occurred. They are listed only as reminders.

The flow charts can be used to gain a fast overview of the questions for a deficiency dimension and skip directly into the middle of the inventory instead of reading through each set of questions.

FINAL NOTE: THE DIAGNOSTIC QUESTION INVENTORY AND FLOW CHARTS ARE GUIDES. THEY ARE NOT INTENDED TO BE A COMPREHENSIVE LIST OF ALL THE QUESTIONS WHICH COULD POSSIBLY BE ASKED DURING THE DIAGNOSTIC PROCESS.

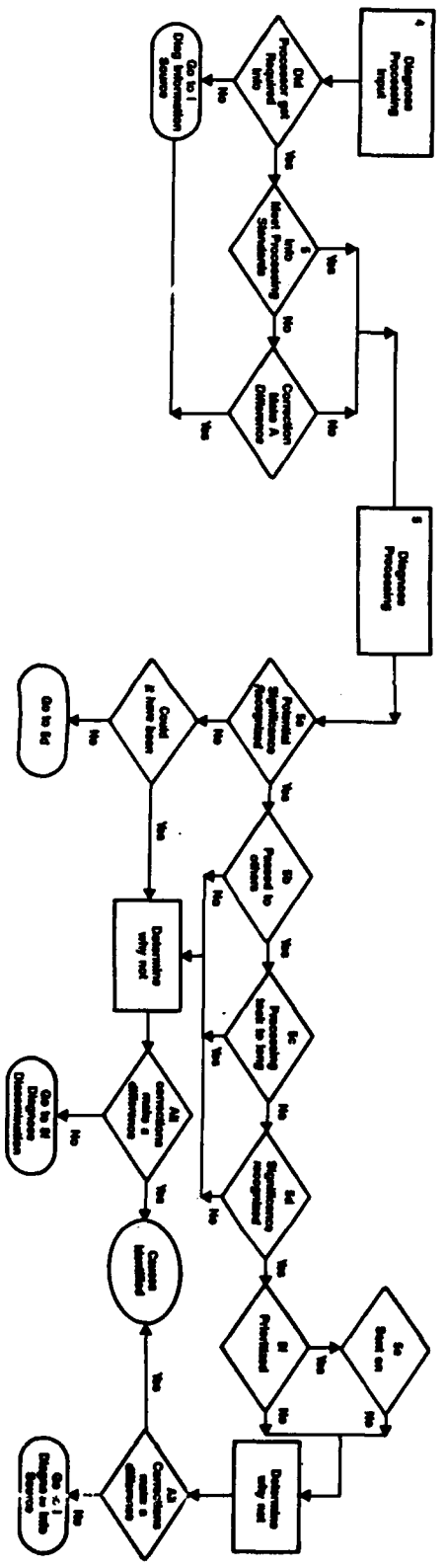
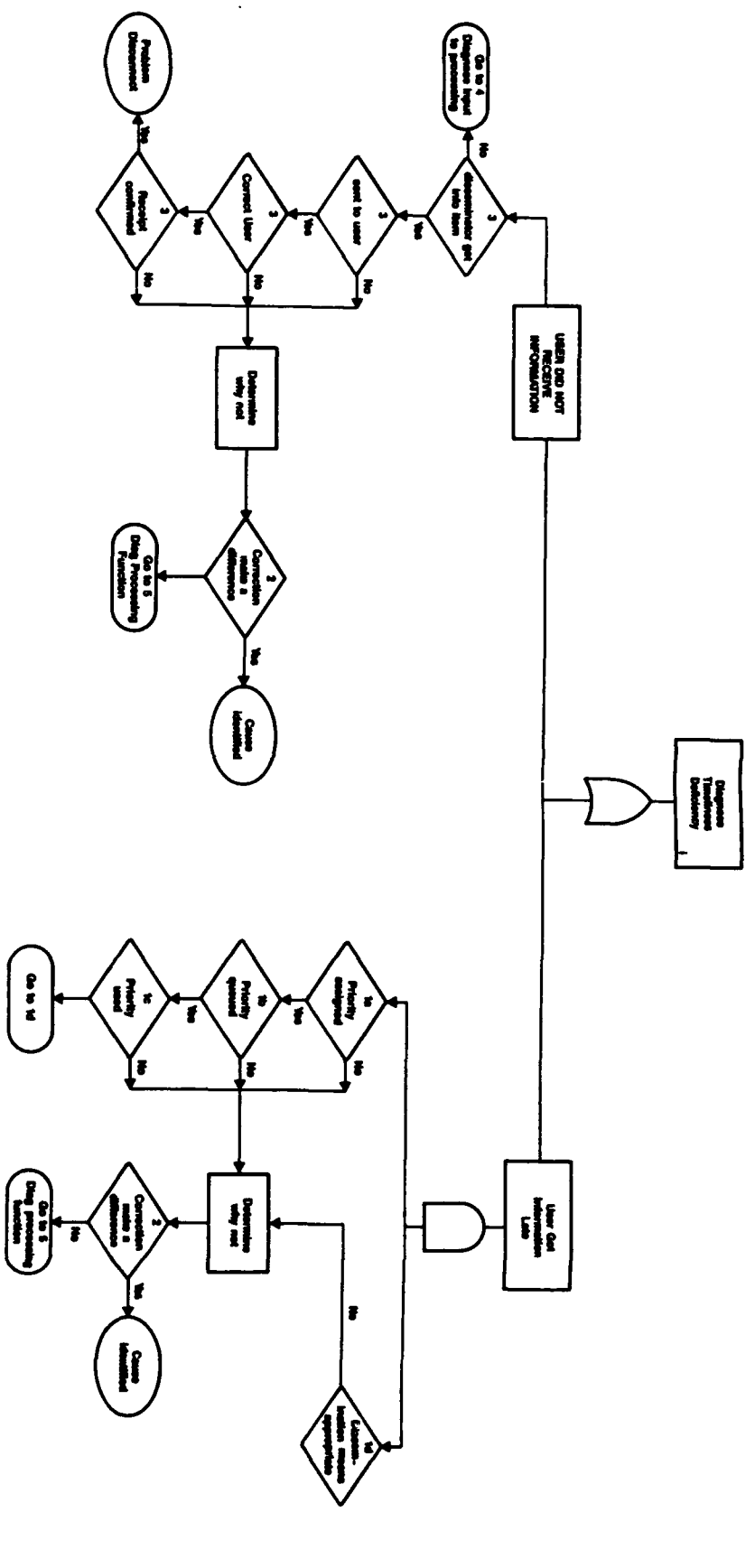

APPENDIX C-7

DIAGNOSTIC QUESTION INVENTORY AND FLOW CHART:

TIMELINESS

Timeliness is unusual in that if you find a possible cause for deficiency, correcting it might not provide enough additional time to have prevented the deficiency. You may be dealing with multiple causes, which together contributed to the deficiency. As a result, you will not always stop asking questions when you have discovered a cause. Follow questioning in sequence unless you are to go to a different question.

The first set of questions is to determine whether something went wrong with dissemination. In other words, something got fouled up getting the information out to the user. Stop asking questions about an information item when you have fully identified what went wrong. Go through each information item on your data sheet. It may become apparent that the same problem is responsible for a deficiency in many items. Use common sense on when to stop asking questions. Item 1a below is a good example. If there are no procedures for prioritizing information, that may affect all deficient items, that doesn't mean questions 1d and 1e should not be asked since they have nothing to do with prioritization.

Questions 1 and 2 are concerned with the dissemination of information from the MI producer to the user without respect to form; it makes no difference if dissemination is a formal briefing, phone call, or radio transmission.

1. Was information item sent to the user? If no, go to Question 3. If yes, then:
 - a. Was a priority placed on getting the information sent? If no, check to see if there were adequate procedures for prioritizing communications. If there weren't, maybe there should be. If there were, why weren't they followed?
 - b. Did the priority cause other information to be sent first, thus delaying dissemination? If yes, was information prioritized correctly, were procedures followed, or was everything done correctly, but more important information needed to be sent out first?
 - c. Did the person responsible for dissemination respond to the priority? If no, why not? If yes, the problem may be identified by Questions 1d or 1e.

- d. Did the person responsible for dissemination select the best means/alternate means to send the information? If no, look again at procedures to determine if they exist, cover the situation, and were followed.
 - e. Was it confirmed that the user received the information? If no, did procedures exist, did they cover the situation, and were they followed? Could confirmation be carried out?
2. If you identified a possible cause for timeliness deficiency, would correcting it have resulted in enough time being saved to have prevented the deficiency? If yes, have you identified the entire cause? If you didn't identify a cause, or if correcting the cause you identified wouldn't have saved enough time, you will have to begin asking about information processing. Go to Question 5.
 3. The information item was not sent to the user. Did the item get sent to the person responsible for disseminating it? If yes, why didn't it get sent? If no, the cause of the deficiency is almost certainly not in the dissemination process.
 4. Did the organization get the information required to produce the information item? If no, determine the organization that should have sent the information. You must go to that organization and ask questions on timeliness.
 5. Did data received meet organization standards necessary to effectively process it? No matter what the answer, proceed with questioning. However, if no, identify and examine the organization(s) from which the data came.
 - a. Was the potential significance of the data or information recognized? If no, it may be that the importance of the data could be recognized only after it had been processed or placed in context with other information. If that is the case, go to Question 5d. If the potential significance could have been recognized, then why wasn't it? Were procedures established to screen incoming data for significance? Did the person have the experience necessary to do the screening? Did he have the training? Were job aids available to assist in the screening? Were aids possible? If available, were they used?
 - b. Was the significance passed on to the people required to process the information? If no, why not?

- c. How long did it take to process the information? The organization may have done everything possible, yet still was unable to get information out in time to be of use. If answers to the next four questions are negative, identify the organization that sent the information to determine if the problem can be solved there. These questions can be asked in any order, but all need to be considered.
- (1) Would additional resources speed information processing? What resources? More people? How many? More equipment? What kind? Automated? Manual? Job aids? What kind? Would additional resources make a difference?
 - (2) Would more effective resources speed information processing? Do all personnel have necessary training and experience? Is correct equipment available and working? Would more effective resources make a difference?
 - (3) Would more effective use of resources speed information processing? Are proper procedures followed? Could procedures be improved? What procedures? Is unnecessary work done? Are all personnel used properly? Equipment? Would more effective use of resources make a difference?
 - (4) Would changes in any combination of the three above make a difference? If changes would have entirely prevented the timeliness deficiency, has the complete cause been identified?
- d. Was the significance of the processed information recognized? If no, were procedures established to identify significant information? Were they followed? Were there job aids to assist? Were they used? Were personnel properly trained? Did they have adequate experience?
- e. Was the information item prioritized for dissemination? Were prioritization procedures established and used?
- f. Was the information sent to the dissemination point? If not, why?

Even when cause(s) are identified, correction must make a difference. Would the time saved, including time saved by correcting dissemination deficiencies, have eliminated the timeliness deficiency? If not, continue questioning the

organization which sent the information. If all questions are answered "yes," the problem is not getting information to the organization fast enough. Do a timeliness diagnosis on the organization from which the information is coming.

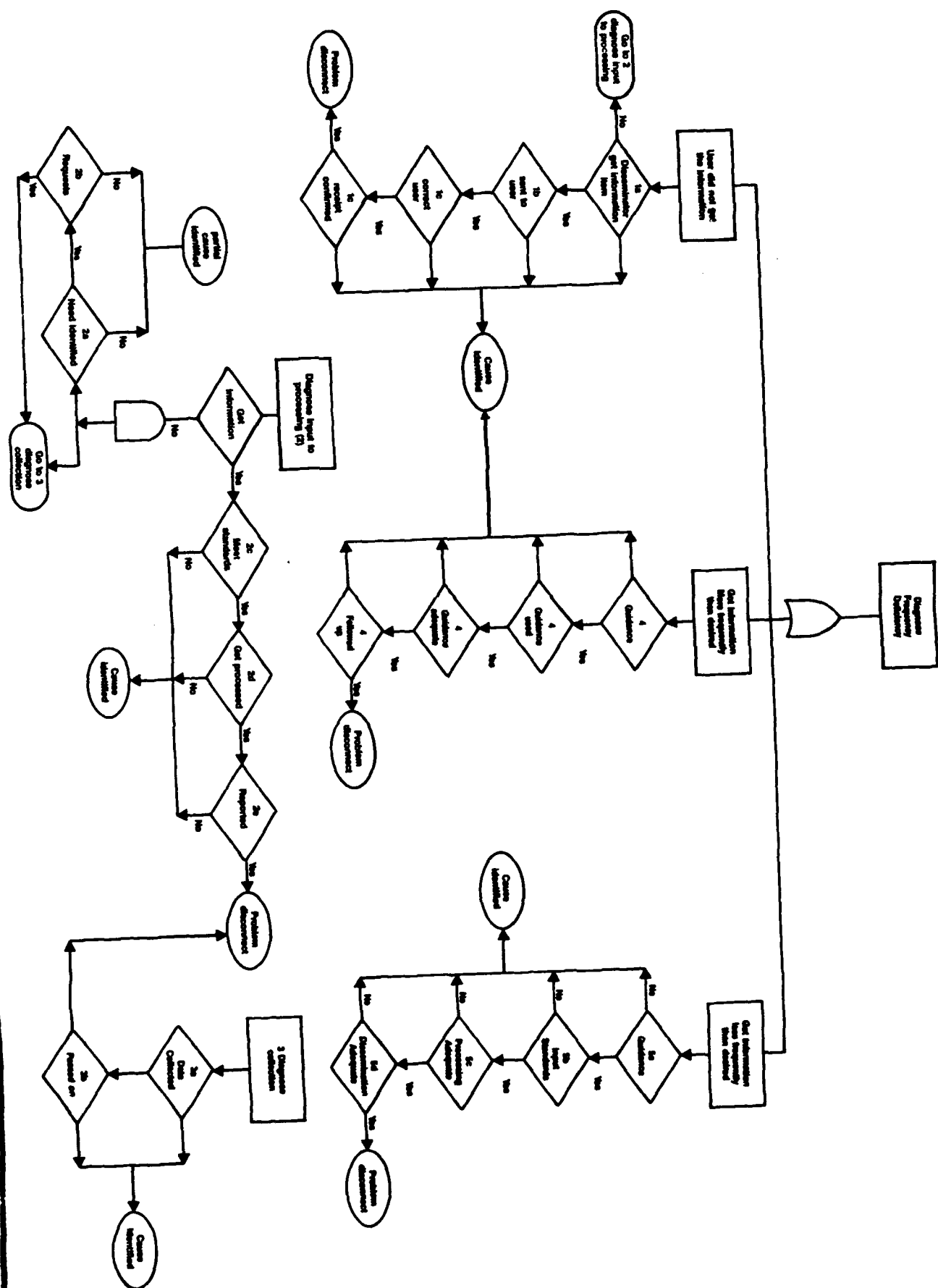

APPENDIX C-8

DIAGNOSTIC QUESTION INVENTORY AND FLOW CHART:

FREQUENCY

There are three ways an information item can be rated unacceptable, based on a frequency deficiency. First, information was not received. Second, it was received, but the user did not get it as frequently as needed; implicit in this deficiency is that information may be late. Finally, information could come in more frequently than required, disrupting operations.

The first set of questions is to determine whether something went wrong with the dissemination, without respect to form; it doesn't matter if dissemination is a formal brief, phone call, or radio transmission.

1. Did the user receive the information? If yes, go to Questions 4 and 5.
 - a. If no, was item sent to the person responsible for disseminating it? If not, diagnose the organization that should have sent it.
 - b. If the item was received, why wasn't it forwarded to the user? Did anyone know the information was there to be sent on? Was a conscious decision made not to send it on? If so, why?
 - c. If it was forwarded, did it go to the correct user? Was it confirmed that the user had received the information? Were there procedures on confirmation? Were they used? Was confirmation possible?
2. Did the organization responsible for producing the information item have information required for processing into the item? If yes, go to 2c.
 - a. If not, did anyone realize they didn't have the information? Were any quality control procedures in effect to identify when or what information might be missing? Were quality control procedures used? Why didn't they work? Did anyone know the information was needed to meet a suspense?
 - b. Were requests made for the information? If not, why? If requests were made, were they made according to procedure? Were requests followed-up? Confirmed? Was

the suspense passed on? If information was requested and not received, diagnose the organization responsible for collecting the information. Go to Question 3.

- c. If they had the information, did it meet standards required to adequately process? If no, did it have any effect on not meeting the suspense? If yes, what was the impact? (This question is to help determine where in the organization you might want to go, or what other questions you may be able to eliminate to identify the cause of the deficiency).
 - d. If the information did not get processed, was the crew aware of the suspense? Was there time enough to produce the information item? Were there higher priority items to be taken care of? Were there enough resources? Human? Material? Were there too many resources? Were there procedures in place to ensure work got done and the suspense met? Did the procedures work?
 - e. If the information was processed, were results reported? If not, why? If so, were they removed from the dissemination? Why?
3. We know from item 2b that requests for the information were made; was the data collected? If not, why? If so, why wasn't it passed on?
- a. Were data requirements passed on to staff responsible for collecting? Were the requirements correctly translated into collection requirements? Were there higher collection priorities which precluded the collection of the data? Were assets available for collecting the data? Were all possible assets considered? Were they assigned? Was an attempt made to collect the data?
 - b. If collected, was collection acknowledged? Were there procedures for passing on the data? Were they followed?
4. Was the item received too frequently, disrupting the operations?
- a. Is there guidance concerning the frequency at which information is to be provided? Guidance can be in the form of SOP, supervisory input, or user feedback. Was guidance used?
 - b. Were user's frequency requirements known? Was action taken to meet them? Were alternative actions possible?
5. Was the information item received less frequently than the user required? Implicit in this situation is that

information could have been consistently provided late; specific instances would be evaluated as a timeliness deficiency.

- a. Was there guidance concerning the frequency the information was provided the user? This guidance could be in the form of SOP, supervisory input, or feedback from the user. Was the guidance used?
- b. Did the data to be processed into the information item meet the standards required for processing? If not, would it have contributed to the information being provided less frequently than required? If so, how?
- c. Were there higher priority information requirements that needed to be processed? Were alternative resources available to produce the information? Were they considered? Did the processing procedure contribute to delay in processing?
- d. Was the deficiency in meeting the frequency standards as a result of the dissemination procedure? Questions 1a through 1e from the timeliness diagnosis can be used for this diagnosis.
- e. Were the user's frequency requirements known? Was action taken to meet them? Were alternative actions possible?

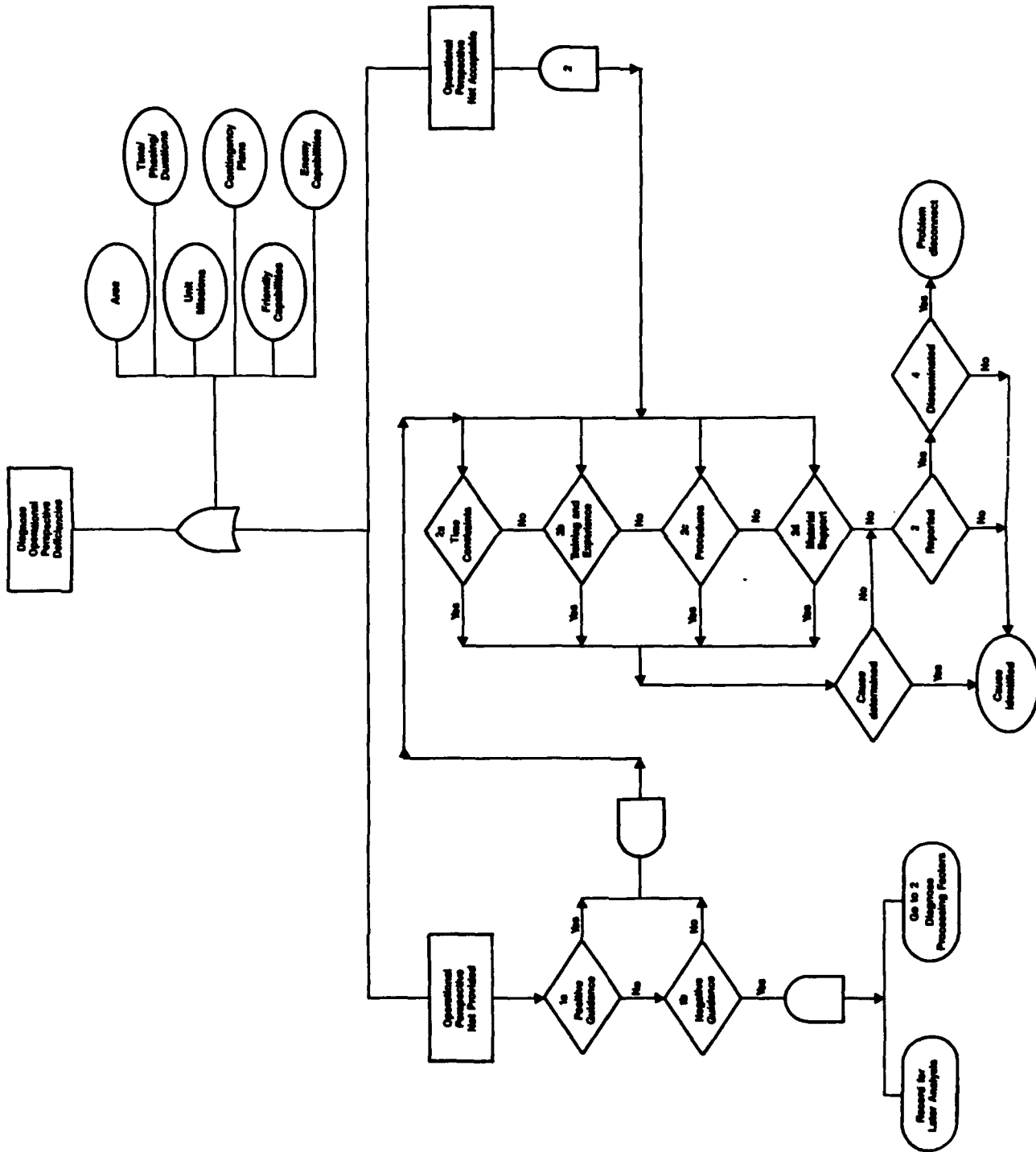

APPENDIX C-9

DIAGNOSTIC QUESTION INVENTORY AND FLOW CHART:

OPERATIONAL PERSPECTIVE

An item can be deficient because operational perspective was not provided or was provided ineffectively. Aspect(s) or operational perspectives not provided or provided poorly should be identified, i.e.:

Area of operations

Time/phasing/duration of the operation

Missions of higher, lower, or adjacent units

Unit contingency plans, in place or in development

Friendly capabilities related to current or future operations

Enemy capabilities related to current or future operations

1. Was the information item placed in operational perspective?
If no, then:
 - a. Was there any guidance to indicate the information should have been put into the specific operational context?
Guidance could include SOP, doctrine, suggestions from supervisors or cohorts, or feedback from the user.
Training and experience in providing operational context should be considered. Guidance can be implicit or explicit. If no, why? Go to Question 2 to determine if having guidance would have made a difference, and to Questions 3 and 4 to determine if there was a reporting or dissemination problem.
 - b. Was there either explicit or implicit guidance that information should NOT be put in operational perspective?
The purpose of this question is to determine if there is a disconnect between what should be done and what is done. If the answer is yes, note the problem and proceed to Question 2. The problem of the disconnect will be addressed outside the diagnostics.
2. Were the necessary factors in place so the information could adequately be put in operational perspective?
 - a. Is there time to place the information in operational perspective? Is the workload such that adding this attribute is traded-off in order to accomplish other requirements?
 - b. Does the staff have the training or experience necessary to put information into operational perspective?
Consider formal military training, on-the-job training,

and experience based on previous jobs, in relation to operational perspective in general and the deficient aspect of operational perspective in specific.

- c. Is the staff knowledgeable of procedures that facilitate placing information in operational perspective? Do they use them? Procedures might include wargaming, consulting with staff external to the group, internal discussion, and brainstorming.
 - d. Does the staff have the job aids, data bases, references, etc., which would help them place information in operational perspective?
3. If information was in operational perspective which wasn't forwarded to the user, was it removed from the report (without regard to how it was presented)? If yes, why?
 4. If operational perspective was in the report, why was it removed from the dissemination?

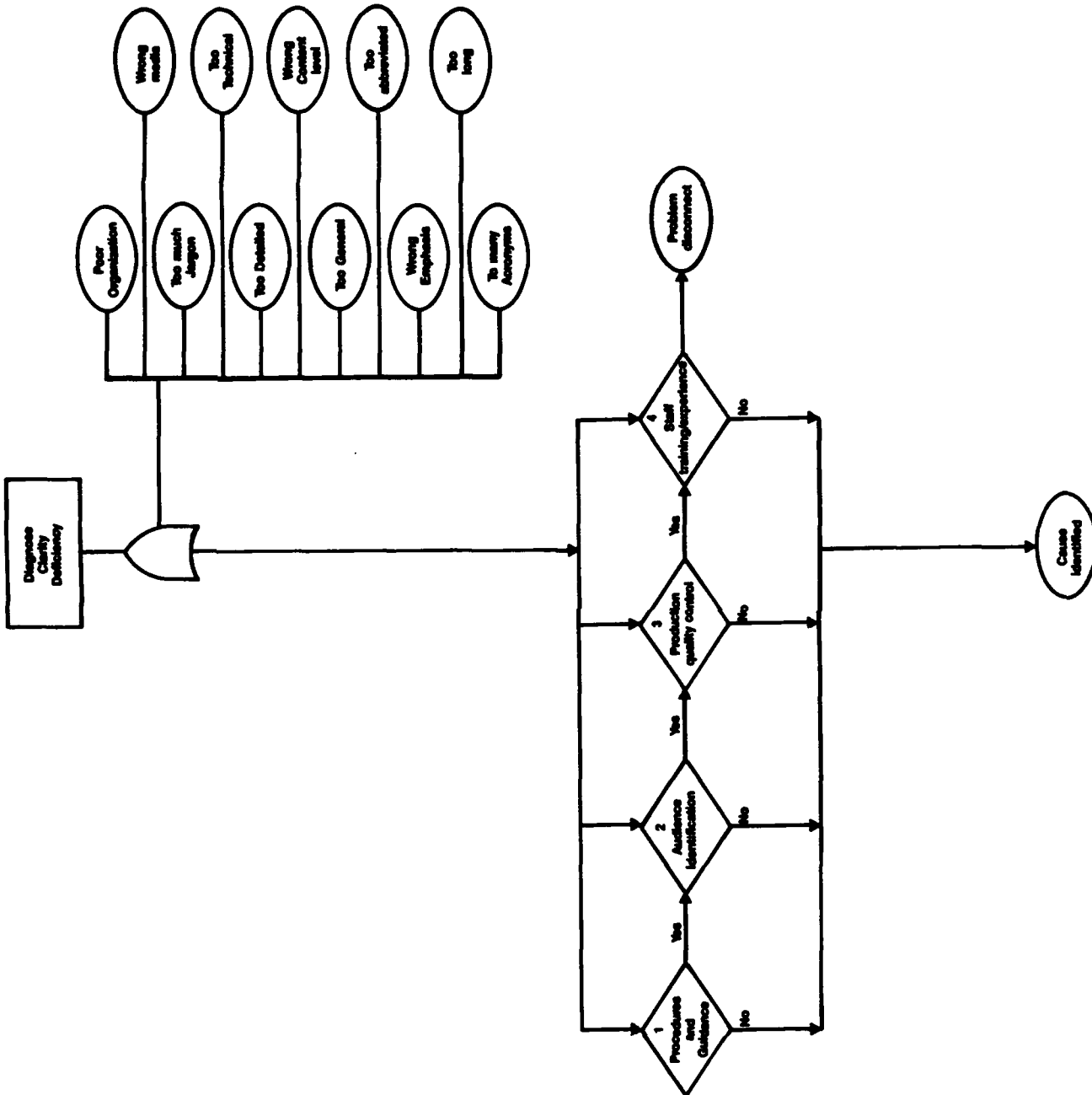

APPENDIX C-10

DIAGNOSTIC QUESTION INVENTORY AND FLOW CHART:

CLARITY

A clarity deficiency concerns information which is difficult to understand or comprehend by the user, regardless of how information is presented. Reason(s) for a clarity deficiency may include any combination of:

- Poor organization
- Too technical or detailed
- Too long or redundant
- Too general or abbreviated
- Too much jargon, too many acronyms
- Wrong areas emphasized
- Content level inappropriate for the user
- Wrong means of presentation

Four major sets of questions should be addressed:

1. Were procedures/guidance available on how to prepare and present information? This could include message formats, briefing guides, Army writing style manuals, field manuals, and internal SOPs within the unit and the command. Were they used? Did they contribute to the problem? Why weren't they used?
2. Was the audience for the information identified? Was it considered when producing or presenting the information? If a multiple audience, were key players identified? Was production or presentation adjusted for each? If one key player, was he identified? Were his unique requirements identified and considered?
3. Was there quality control of the production? Was someone responsible for checking the clarity of the information? Was it done? Was there enough time for quality control? If it was done, were corrective actions initiated? Followed up?
4. Was the staff adequately trained to produce or present the information? Did they understand what was being produced/presented? Was it SOP to use jargon, acronyms, or technical language? Was it SOP to be brief or detailed in carrying out their responsibilities? Was lack of organization a common characterization or a unique event?

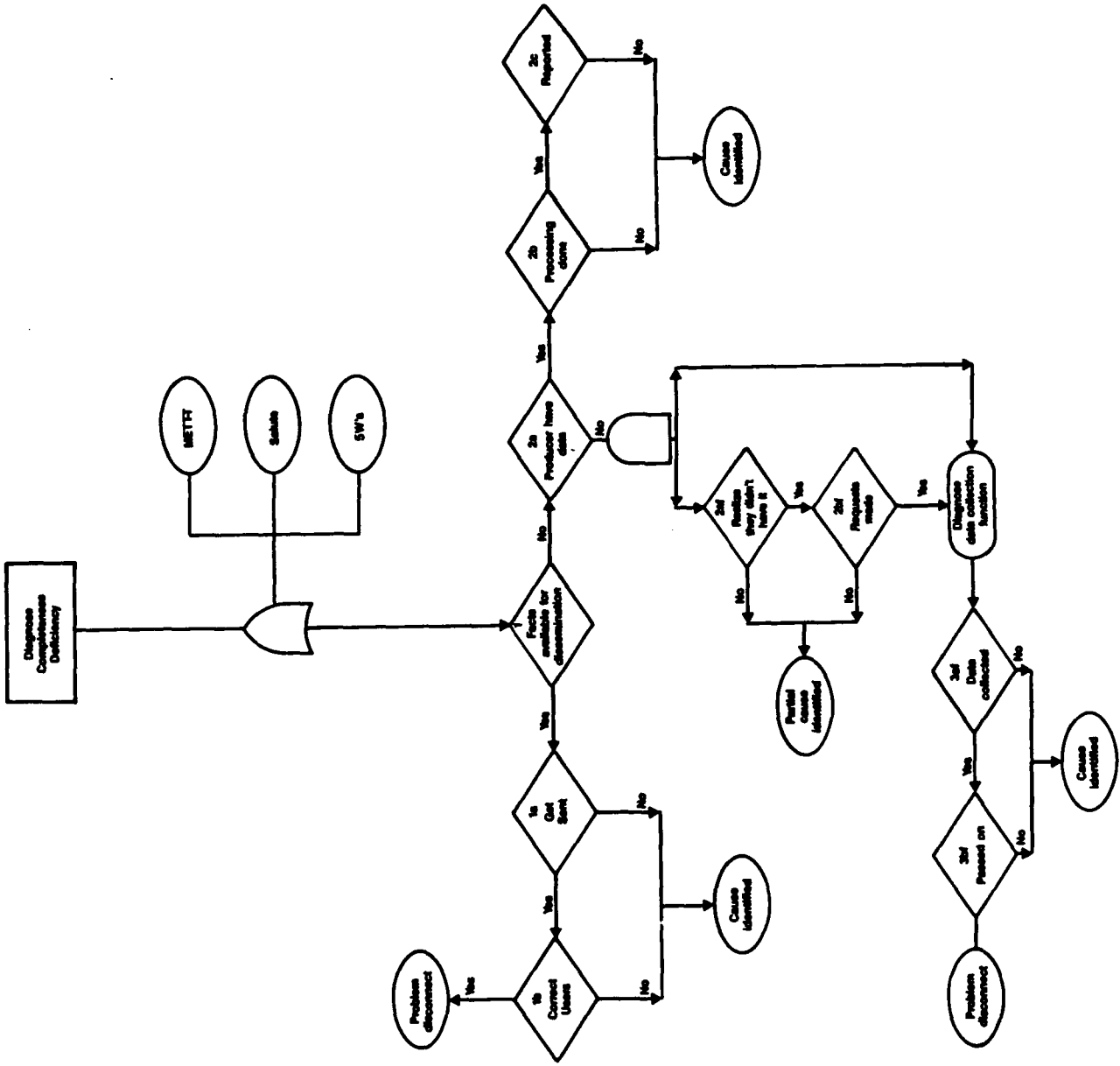

APPENDIX C-11

DIAGNOSTIC QUESTION INVENTORY AND FLOW CHART:

COMPLETENESS

An item is deficient if missing factual content (5W/H, SALUTE, METT-T). An absence of facts, however, does not distract if the absence is identified and explained. Diagnosis must be guided by specific mission fact(s).

1. Were the missing facts available for dissemination? If no, go to Question 2.
 - a. Why didn't they get sent to the user? Did anyone know they were there to be sent on? Was a conscious decision made not to send it on?
 - b. If they were forwarded, did they go to the correct user? Was it confirmed that the user received them? Were there procedures for confirmation? Were they used? Was confirmation possible?
2. If data had to be processed in some way to develop the factual content of the information item, did the staff doing the processing have the necessary data? If no, diagnose data collector as well as data processor.
 - a. If the processor didn't have the data, then Questions 2a and 2b in the frequency analysis are appropriate.
 - b. If the processor had the data, why wasn't it processed? Was it lost in the normal course of events? Did the staff know the data was supposed to be processed for the item? Were guidelines or references available to help the staff? Did they have necessary training or experience to carry out the processing? Was someone responsible for quality controlling the outputs? Did it get done? Were corrections for deficiencies noted during quality control directed? Was the direction followed up?
 - c. If the data was processed, was it included in the reporting? If not, why not? If it got reported, did it get lost in the dissemination?
3. Was the data collected? With minor modifications, Question 3 of the frequency diagnosis is appropriate.

APPENDIX C-12

DIAGNOSTIC RECORD

DIAGNOSTIC RECORD

Inquiry Data (include location)	Problem(s) Identified	Information Deficiencies	Causes	Recommended Solutions

APPENDIX C-13

INSTRUCTIONS FOR THE USE OF THE
DIAGNOSTIC RECORD FORM

The purpose of this form is to help you document your analysis so that you can systematically present and support the conclusions from your diagnosis. The form should be filled out one deficiency at a time.

- Step 1. Record in the "inquiry data" column the important data that you gathered when asking questions about the deficiency.
- Step 2. Record in the "problem(s) identified" column your conclusion as to what the problem(s) was based on the data from the first column.
- Step 3. Record what the deficiency resulted. This is a restatement of the original deficiency you diagnosed.
- Step 4. In the cause of the deficiency column, record your conclusions based on the data from the first column, as to what caused the problem identified in the second column.
- Step 5. Filling in recommendations to solve the problem is optional. If by experience or comfort you think you have a good solution to the problem, record it. However, the purpose of the diagnostics is to identify problems and the causes, not offer remedy.

APPENDIX D

COMPUTING SCORES FROM THE DEFICIENCY CONSOLIDATION WORKSHEET

Computing the four scores, comprehensiveness, criticality, effectiveness, and distribution of ratings is described below. The scores are computed from the example consolidation worksheet and Performance Rating Form). The example is only for one section of the worksheet, enemy courses of action, and one rating period. Also, the observer participant's weights have been recorded on the worksheet (identified by the A) from the Information Requirements Profile. ITEMS ON THE WORKSHEET AND FORM ARE IDENTIFIED FOR PROVIDING THE EXAMPLES. IT IS NOT PART OF THE COMPUTATION. The scores based on all the worksheets for each rating period are computed in the same manner described.

WHEN COMPUTING A TOTAL SCORE AN INFORMATION ITEM IS ONLY COUNTED AS BEING DEFICIENT ONCE, EVEN IF IT WAS DEFICIENT IN MORE THAN ONE DIMENSION.

Comprehensiveness--total score

There are a total of 14 items which were rated. Four (identified by the C) show no deficiencies in any of the five areas. The comprehensiveness score is the number of non-deficient items divided by the number of items rated. The result is multiplied by 100 to get a percent.

$$\begin{aligned}\text{Comprehensiveness} &= (4/14) \times 100 \\ &= .29 \times 100 \\ &= 29\% \quad (\text{this is probably not a good score})\end{aligned}$$

Criticality--total score

There are 10 items that were rated deficient. They had weights of 40, 70, 80, 100, 70, 100, 80, 70, 40, and 90. The weights came out of the column identified with the A for items identified by the D. The sum of the weights of the deficient items is 740.

The criticality score is the sum of the weights of the deficient items divided by the number of deficient items.

$$\begin{aligned}\text{Criticality} &= 740/10 \\ &= 74 \quad (\text{Moderately critical items were deficient})\end{aligned}$$

Effectiveness--total score

There are 4 items not deficient (identified by the C). They have weights of 70, 80, 80, and 60. The sum of these weights is 290. The effectiveness score is the sum of the weights of the non-deficient items divided by the sum of the weights of all items. The result is multiplied by 100 to get a percent.

$$\begin{aligned}\text{Effectiveness} &= (290/1030) \times 100 \\ &= .28 \times 100 \\ &= 28\% \text{ (not a good score)}\end{aligned}$$

The three scores illustrated can also be computed for each dimension. Computation of the clarity scores is described. Scores for the other deficiency dimensions are computed the same way.

Comprehensiveness--clarity

There were only 10 items that were rated for clarity. Since four information items were not received by the G3 plans, they could not be rated on any area except timeliness. There were seven items not deficient on clarity.

$$\begin{aligned}\text{Comprehensiveness for clarity} &= \\ &(7/10) \times 100 = 70\%\end{aligned}$$

Criticality--clarity

The three deficient items for clarity had weights of 70, 80, and 100.

$$\begin{aligned}\text{Criticality-clarity} &= \\ &250/3 = 83\end{aligned}$$

Effectiveness--clarity

The seven non-deficient items for clarity had scores of 70, 80, 80, 60, 80, 70, and 90.

$$\begin{aligned}\text{Effectiveness-clarity} &= \\ &(530/780) \times 100 = 68\%\end{aligned}$$

Distribution of performance ratings

The distribution of performance ratings, while not a score, represent the percent of time a specific performance scale value was selected for any of the dimensions. It is determined by counting how many times the item was given a performance scale value, divided by the number of times the item was rated.

From the example Performance Rating Form, enemy courses of action, there were 14 timeliness ratings. To compute the percent for any performance scale value, divide the number of times the specific value occurred by the number of items rated. Multiply that result by 100 to get the percent.

Timeliness Performance

Scale Value	Frequency	Percent
1	5	36
2	0	0
3	2	14
<hr/>		
4	3	21
5	4	29

The line between performance scale value 3 and 4 represents the benchmark identified by the observer-participant.

The other areas are done the same way, except they only have 10 ratings. Four items were not received and could only be rated for timeliness.

The scores can be presented in graphs or tables as shown on the following pages.

Performance Rating Form

(part 2 of 2)

TIMELINESS RATINGS

- Check one: 1 Reached in target time
 2 Reached, had to wait
 3 Reached, required extra resources
 4 Reached too late
 5 Did not receive

FREQUENCY RATINGS

- Check one: 1 Often enough
 2 Too often but acceptable
 3 Too often and disruptive
 4 Not often enough
 5 Did not receive

OPERATIONAL PERSPECTIVE RATINGS

- Check one: 1 Very, efficient perspective
 2 Reason to buy aspects of communication ops
 3 Reason to assess aspects of communication ops
 4 Does not relate to communication ops
 5 No perspective provided

CLARITY RATINGS

- Check one: 1 Easy to understand
 2 Easy to understand with comparison
 3 Understandable with familiarization
 4 Required extensive familiarization to understand
 5 Not understandable

COMPLETENESS RATINGS

- Check one: 1 No gaps
 2 Some gaps though explained
 3 Some gaps with no explanation
 4 Many gaps with no explanation
 5 Too many gaps to use

SAMPLE OPERATIONAL PERSPECTIVE DEFICIENCIES

OPERATIONAL PERSPECTIVE NOT RELATED TO:

- A Area of Operations
- B Area of Interest
- C Transmittability of operations
- D Medium of higher, lower, or adjacent units
- E Unit connectivity plans in place or in development
- F FR capabilities related to current or future ops
- G EN capabilities related to current or future ops

SAMPLE CLARITY DEFICIENCIES

- A Plainly organized
- B Too much jargon
- C Too detailed
- D Too long
- E Too many acronyms
- F Inappropriate presentation media
- G Too technical
- H Too abbreviated
- I Emphasis in wrong areas
- J Content level inappropriate for recipient
- K Inappropriate presentation media

SAMPLE COMPLETENESS DEFICIENCIES

- A Mission
- B Size
- C Enemy
- D Terrain
- E Weather
- F Troops
- G SALUTE
- H Who
- I Activity
- J Location
- K What
- L When
- M Why
- N How

NAME _____
 POSITION _____
 DATE _____

NAME	POSITION	DATE	Timeliness Rating (1-5)	Frequency Rating (1-5)	Operational Perspective Rating (1-5)	Clarity Rating (1-5)	Completeness Rating (1-5)
ENEMY COURSES OF ACTION							
Enumerate Possible ECOAs							
Mission			1	1	2	3	2
Objectives			3	1	2	3	2
Forces			3	1	2	3	2
Terrain considerations			5	1	2	1	2
Echelonment			1	4	3	4	2
Main supporting efforts			1	4	2	4	2
Fires (including air support)			3	1	2	3	2
Time/distance factors			3	1	2	3	2
Threat advance			1	1	2	3	2
Probability			4	1	2	3	2
Analysis of Probable ECOAs			4	1	2	3	2
Enemy strengths			4	1	2	3	2
EN Vulnerabilities			4	1	2	3	2
Friendly high value targets			4	1	2	3	2
Enemy intentions			4	1	2	3	2
EN RECCE/Intelligence			1	1	2	3	2
EN RECCE/Intelligence capabilities			1	1	2	3	2
Recent Intel activities/indicators			1	1	2	3	2
Effects of EN Intel on FR operations			1	1	2	3	2
EN Radio Electronic Combat			1	1	2	3	2
REC capabilities			1	1	2	3	2
Recent & significant REC activities			1	1	2	3	2
Effects of REC on FR operations			1	1	2	3	2
EN Special Operations			1	1	2	3	2
EN special ops capabilities			1	1	2	3	2
Recent/significant special ops activities			1	1	2	3	2
Effects of EN special ops on FR ops			1	1	2	3	2
Friendly Vulnerabilities			1	1	2	3	2
Friendly high value targets			1	1	2	3	2
Effects of vulnerabilities on FR operations			1	1	2	3	2
Deception			1	1	2	3	2
Deception capabilities			1	1	2	3	2
Recent & significant deception activities			1	1	2	3	2
Effects of deception on FR operations			1	1	2	3	2
OPERATIONS SECURITY							

DEFICIENCY CONSOLIDATION WORKSHEET

(A)

ENEMY COURSES OF ACTION		Timeliness	Frequency	Oper Perspective	Clarity	Completeness
C	Mission 70					
C	Objectives 80					
C	Forces 80					
C	Terrain considerations 60					
D	Echelonment 40	G3P-NR				
D	Main/supporting efforts 70		G3P		G3P-ABE	
D	Fire (including air support) 80		G3P		G3P-AEI	
D	Time/distance factors 100	G3P-NR				
D	Threat advance 70	G3P-NR				
D	Probability 100				G3P-J	
D	Enemy strengths 80	G3P				
D	EN Vulnerabilities 70	G3P	G3P			
D	Friendly high value targets 40	G3P-NR				
D	Enemy intentions 90	G3P	G3P	G3P		

14 ITEMS
sum of weights = 1030

EXAMPLE OF DATA PRESENTATIONS:

If you wanted to show MI performance on a rated dimension for the different rating periods:

TIMELINESS

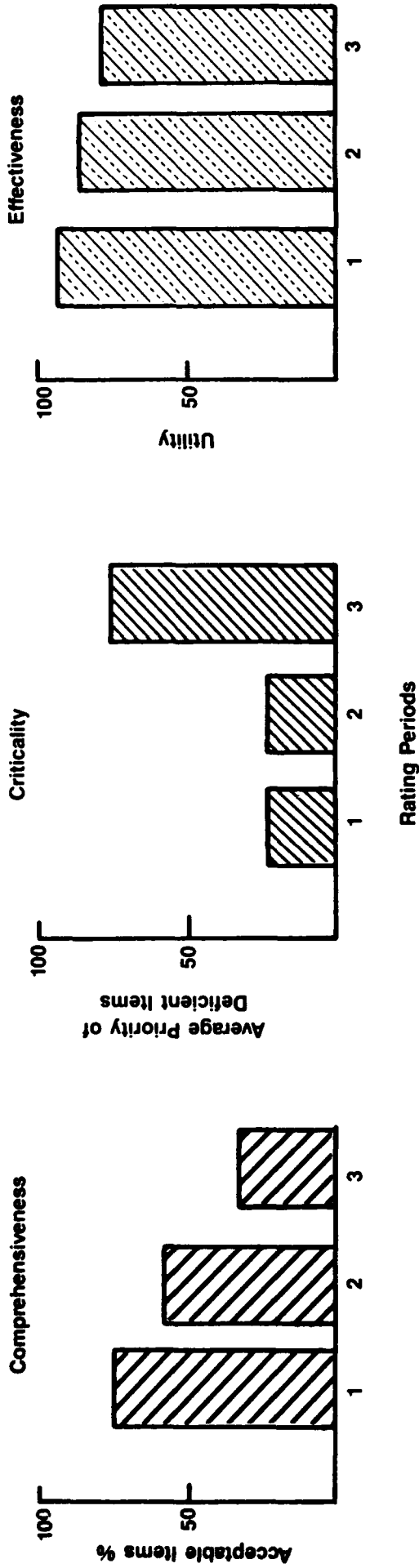

This figure shows that on the dimension of timeliness performance got worse on all measures.

If you wanted to show MI performance on a measure for a rating period for all dimensions:

Criticality - Rating Period 2

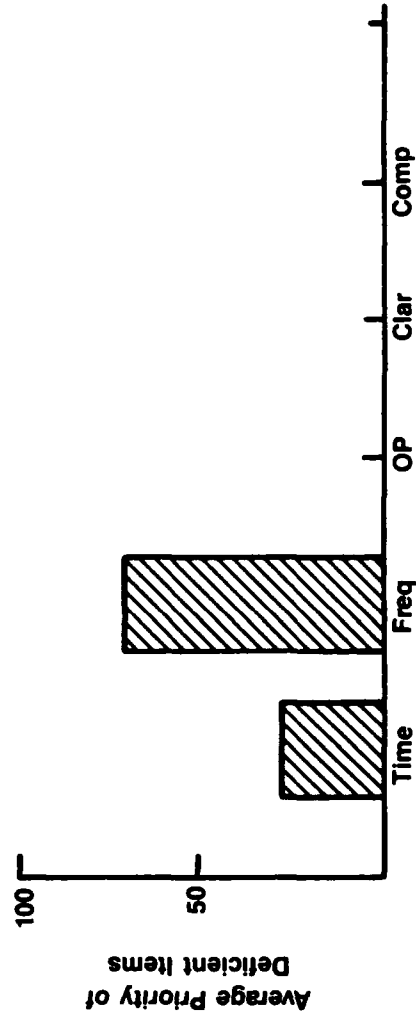

This shows that items with frequency deficiencies were of moderately high priority.

If you are interested in rating distributions, the presentation should be by individual dimension. How well did MI perform on timeliness during the first rating period?

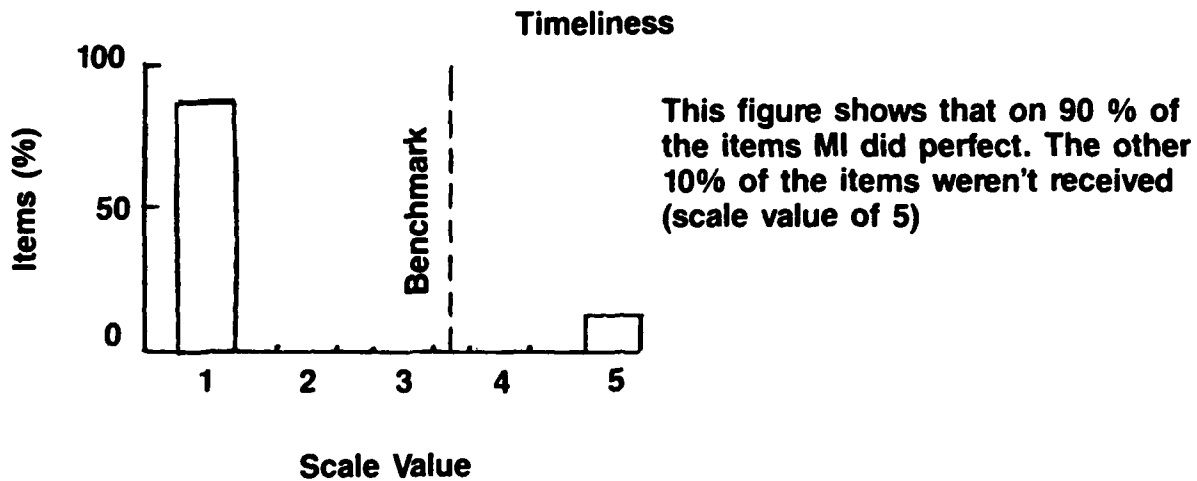

If you were interested in the rating trend for a dimension then:

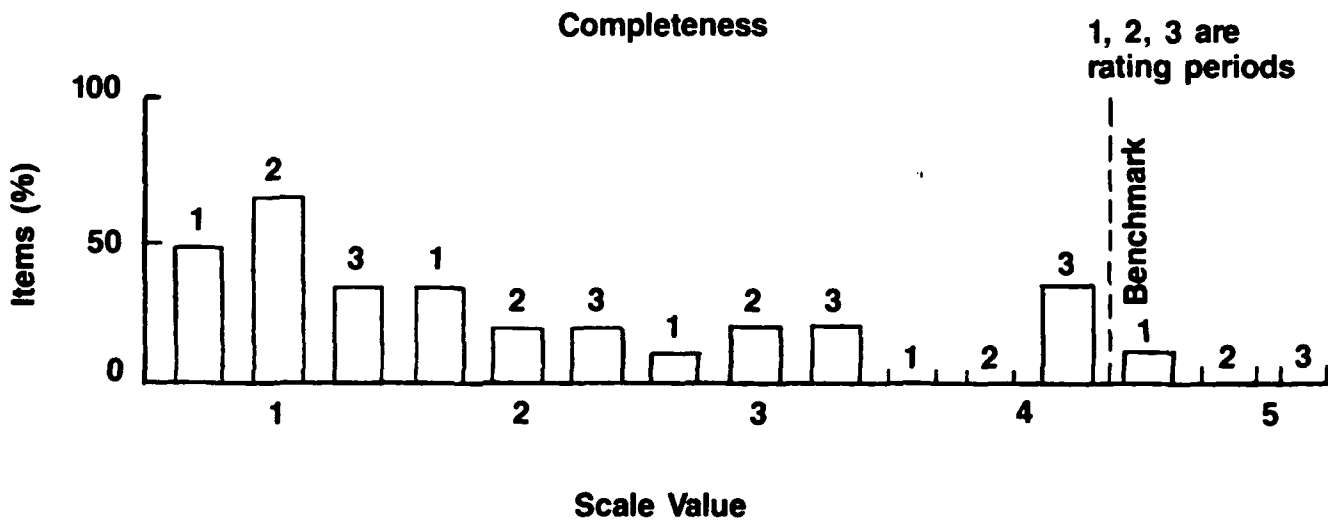

This figure shows relative flat performance, i.e., nothing bad, but not perfect either. The trend shows rating period 3 to have the most variable performance, even though no item was below the benchmark for completeness.

What can be shown on a graph can be shown in tabular form also.

DIMENSION	MEASURE	RATING PERIOD		
		1	2	3
Timeliness	Comprehensiveness	80%	85%	90%
	Criticality	20%	20%	75%
	Effectiveness	95%	95%	95%
Frequency	Comprehensiveness	90%	100%	100%
	Criticality	40%	0	0
	Effectiveness	95%	100%	100%

**RATING PERIOD 1
MEASURES**

DIMENSION	COMPREHENSIVENESS	CRITICALITY	EFFECTIVENESS
Timeliness	60%	50%	75%
Frequency	80%	30%	70%
Operational Perspective	95%	90%	95%
Clarity	95%	30%	95%
Completeness	95%	40%	95%