

4

AD-A228 389

R D & E

C E N T E R

Technical Report

No. 13492

**FINITE ELEMENT STRESS ANALYSIS FOR
COMPONENT ADVANCED TECHNOLOGY TEST BED (CATTB)**

MAY 1990

**DTIC
ELECTE
OCT 24 1990
S B D**

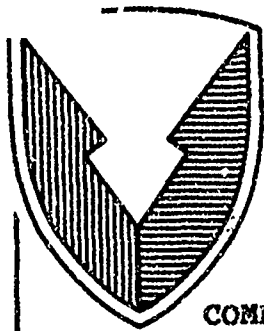

... contains color
... All DTIC reproductions
... be in black and
...

**By Samir Khourdaji
U.S. Army Tank-Automotive Command
ATTN: AMSTA-TDS
Warren, MI 48397-5000**

**APPROVED FOR PUBLIC RELEASE
DISTRIBUTION IS UNLIMITED**

90 10 23 185

**U.S. ARMY TANK-AUTOMOTIVE COMMAND
RESEARCH, DEVELOPMENT & ENGINEERING CENTER
Warren, Michigan 48397-5000**

Unclassified

SECURITY CLASSIFICATION OF THIS PAGE

REPORT DOCUMENTATION PAGE

Form Approved
OMB No. 0704-0188
Exp Date: Jun 30, 1986

1a. REPORT SECURITY CLASSIFICATION Unclassified		1b. RESTRICTIVE MARKINGS	
2a. SECURITY CLASSIFICATION AUTHORITY		3. DISTRIBUTION / AVAILABILITY OF REPORT Approved for Public Release Distribution is Unlimited	
2b. DECLASSIFICATION / DOWNGRADING SCHEDULE		4. PERFORMING ORGANIZATION REPORT NUMBER(S)	
4. PERFORMING ORGANIZATION REPORT NUMBER(S)		5. MONITORING ORGANIZATION REPORT NUMBER(S)	
6a. NAME OF PERFORMING ORGANIZATION U.S. Army Tank-Automotive Command	6b. OFFICE SYMBOL (if applicable) AMSTA-TDS	7a. NAME OF MONITORING ORGANIZATION	
6c. ADDRESS (City, State, and ZIP Code) Warren, MI 48397-5000		7b. ADDRESS (City, State, and ZIP Code)	
8a. NAME OF FUNDING / SPONSORING ORGANIZATION	8b. OFFICE SYMBOL (if applicable)	9. PROCUREMENT INSTRUMENT IDENTIFICATION NUMBER	
8c. ADDRESS (City, State, and ZIP Code)		10. SOURCE OF FUNDING NUMBERS	
		PROGRAM ELEMENT NO.	PROJECT NO.
		TASK NO.	WORK UNIT ACCESSION NO.
11. TITLE (Include Security Classification) Finite Element Stress Analysis for Component Advanced Technology Test Bed Tracked Vehicle (CATTB) (UNCLASSIFIED)			
12. PERSONAL AUTHOR(S) Khourdaji, Samir			
13a. TYPE OF REPORT Final	13b. TIME COVERED FROM 88 Dec TO 89 Dec	14. DATE OF REPORT (Year, Month, Day) May 1990	15. PAGE COUNT
16. SUPPLEMENTARY NOTATION			
17. COSATI CODES		18. SUBJECT TERMS (Continue on reverse if necessary and identify by block number)	
FIELD	GROUP	SUB-GROUP	
		Stress Analysis, Mass Properties, Dynamic Analysis Turret, Hull, Bulkhead, Road Load, Firing Load.	
19. ABSTRACT (Continue on reverse if necessary and identify by block number) This program was initiated to study the effect of the new lightweight gun configuration on the turret and hull; to determine the physical and ride properties of CATTB; and to ensure that the stresses in various CATTB components under gun firing and terrain loads are within safe limits. Road testing will be conducted after the prototype is built to verify analysis results.			
<i>Original contains color plates: All DTIC reproductions will be in black and white</i>			
20. DISTRIBUTION / AVAILABILITY OF ABSTRACT <input checked="" type="checkbox"/> UNCLASSIFIED/UNLIMITED <input type="checkbox"/> SAME AS RPT. <input type="checkbox"/> DTIC USERS		21. ABSTRACT SECURITY CLASSIFICATION Unclassified	
22a. NAME OF RESPONSIBLE INDIVIDUAL Samir Khourdaji		22b. TELEPHONE (Include Area Code) (313) 574-5875	22c. OFFICE SYMBOL AMSTA-TDS

NOTICES

This report is not to be construed as an official Department of the Army position.

Mention of any trade names or manufacturers in this report shall not be construed as an official endorsement or approval of such products or companies by the U.S. Government.

Destroy this report when it is no longer needed. Do not return it to the originator.

TABLE OF CONTENTS

SECTION	PAGE
1 Summary	1
2 Introduction	2
3 Discussion	3
4 Results	4
4.1 Solid Modeling	4
4.1.1 Turret Solid Model	4
4.1.2 Turret Mass Properties	4
4.1.3 Hull Solid Model	5
4.1.4 Hull Mass Properties	5
4.2 Static Finite Element Analysis	23
4.2.1 Turret Finite Element Model	23
4.2.2 Turret Applied Load	23
4.2.3 Turret Analysis (Turret Independent)	24
4.2.3.1 IRM Analysis Results	
4.2.3.2 NISA Analysis Results	
4.3.4 Turret Analysis (Turret as part of Chassis)	24
4.2.4.1 IRM Results	
4.2.4.2. NISA Results	
4.2.5 Trunnion Model	40
4.2.6 Trunnion Applied Load	40
4.2.7 Trunnion Analysis Results	40

40 For	
40 &I	<input checked="" type="checkbox"/>
40 ed	<input type="checkbox"/>
40 ion	<input type="checkbox"/>

By _____	
Distribution/	
Availability Codes	
Dist	Avail and/or Special
A-1	



4.2.8	Turret and Hull Casting	47
4.2.9	Casting Analysis Results	47
4.2.9.1	Gun Firing at 0 degrees Horizontal	47
4.2.9.2.	Gun Firing at 90 degrees Horizontal	47
4.2.10	Hull Model	58
4.2.11	Hull Applied Load	58
4.2.12	Hull Analysis Results	58
4.2.12.1	Gun Firing at 0 degrees Horizontal	
4.2.12.2	Gun Firing at 90 degrees Horizontal	
4.2.13	Hull Modification (reduction of opening in middle bulkhead)	59
4.2.14	Hull Analysis Results	
4.2.15	Hull Modification (add top plate to casting)	59
4.2.16	Hull Analysis Results	
4.2.17	Hull Modification (reduction of rear bulkhead height)	59
4.2.18	Hull Analysis Results	59
4.2.19	Sponsons, Skirts and Outriggers	86
4.3	Dynamic Analysis	105
4.3.1	DADS Model	105
4.3.2	DADS Results	106
4.3.2.1	Terrain Effects	106
4.3.2.2	Firing Load Effects	107
4.4	Dynamic Finite Element Analysis	153
4.4.1	Dynamic Effects of Terrain Forces	153
4.4.2	Dynamic Effects of Firing Forces	154
5.	Conclusions	167
6.	Recommendations	168
Appendix	A Turret Mass Properties	
	B Hull Mass Properties	
	C Turret Support Reactions	
	D DADS Model File	
Distribution List		

LIST OF ILLUSTRATIONS

Figure	Title	Page
1	Turret Geometry	11
2	Turret Geometry	12
3	Turret Geometry	13
4	Turret Solid Model	14
5	Turret Solid Model	15
6	Turret Solid Model	16
7	Turret Solid Model	17
8	Turret Solid Model	18
9	Hull Solid Model	19
10	Hull Solid Model	20
11	Hull Solid Model	21
12	Suspension Solid Model	22
13	CATTB Turret with Conventional Trunnion	25
14	Stresses in CATTB Turret (Conventional Trunnion)	26
15	Deflections in CATTB (Conventional Trunnion)	27
16	CATTB Turret (New Trunnion)	28
17	CATTB Turret FEM Model	29
18	CATTB Turret (Casting)	30
19	IRM Stress Results (Turret Independant)	31
20	IRM Stress Results (Turret Independant)	32
21	IRM Stress Results (Turret Independant)	33
22	IRM Deflection Results (Turret Independant)	34

Figure	Title	Page
23	NISA Stress Results (Turret Independant)	35
24	NISA Deflection Results (Turret Independant)	36
25	NISA Stress Results (Turret as part of Chassis)	37
26	NISA Deflection Results (Turret as part of Chassis)	38
27		39
28		40
29	Trunnion FEM Model	42
30	Trunnion Stress Results (Firing Load)	43
31	Trunnion Stress Results (Firing Load)	44
32	Trunnion Stress Results (Pretension Load)	45
33	Trunnion Deflection Results (Firing Load)	46
34	Stresses in Turret and Hull casting (Top View) gun firing at 0°	48
35	Stresses in Turret and Hull casting (Bottom View) gun firing at 0°	49
36	Stresses in Turret and Hull casting (Front View) gun firing at 0°	50
37	Stresses in Turret and Hull casting (Trunnion Area) gun firing at 0°	51
38	Stresses in Turret and Hull casting (Trunnion Area) gun firing at 0°	52
39	Vertical Deformations in Turret and Hull casting gun firing at 0°	53
40	Stresses in Turret and Hull casting gun firing at 90°	54
41	Stresses in Turret and Hull casting gun firing at 90°	55
42	Lateral Deflection in Turret and Hull casting gun firing at 90°	56

Figure	Title	Page
43	Stresses in Turret and Hull casting (Trunnion Area) gun firing at 90°	57
44	CATTB Hull FEM Model	60
45	CATTB Hull Geometry Model	61
46	CATTB Chassis FEM Model (Turret in normal position)	62
47	CATTB Chassis FEM Model (Turret in normal position)	63
48	Stress in CATTB Chassis (gun firing in normal position)	64
49	CATTB Chassis FEM Model (Turret rotated 90°)	65
50	Stresses in CATTB Chassis (gun firing at 90° - 2 RW are fixed)	66
51	Stresses in CATTB Chassis (gun firing at 90° - 7 RW are fixed)	67
52	Deflections in CATTB Chassis (gun firing at 90° - 7 RW are fixed)	68
53	Deformed shape of CATTB Chassis (gun firing at 90° - 7 RW are fixed)	69
54	CATTB Hull FEM Model (Modification 1)	70
55	Stresses in Modified (1) CATTB Hull (gun firing at 90° - 2 RW are fixed)	71
56	Stresses in Modified (1) CATTB Hull (gun firing at 90° - 7 RW are fixed)	72
57	Deflection in Modified (1) CATTB Hull (gun firing at 90° - 2 RW are fixed)	73
58	Deflection in Modified (1) CATTB Hull (gun firing at 90° - 7 RW are fixed)	74
59	Stresses in Modified (2) CATTB Hull (gun firing at 90° - 7 RW are fixed)	75
60	Deflections in Modified (2) CATTB Hull (gun firing at 90° - 7 RW are fixed)	76

Figure	Title	Page
61	Stresses in Modified (3)CATTB Hull (gun firing at 90° - 7 RW are fixed)	77
62	Stresses in Modified (3)CATTB Hull (gun firing at 90° - 7 RW are fixed)	78
63	Stresses in Modified (3)CATTB Hull (gun firing at 90° - 7 RW are fixed)	79
65	Deflections in Modified (3)CATTB Hull (gun firing at 90° - 7 RW are fixed)	81
66	Deflection in Modified (3)CATTB Hull (gun firing at 90° - 7 RW are fixed)	82
67	Shear Stress in Modified (3) CATTB Hull (gun firing at 90° - 7 RW are fixed)	83
68	Deformed shape for CATTB Chassis (gun firing at 90° - 7 RW are fixed)	84
69	Deformed shape for CATTB Chassis (gun firing at normal position)	85
70	Left Sponson and Skirt FEM Model	89
71	Stress in Sponson and Skirt (1 G Lateral)	90
72	Deflection in Sponson and Skirt (1 G Lateral)	91
73	Stress in Sponson and Skirt (Combined Acceleration)	92
74	Lateral Deflection in Sponson and Skirt (Combined Acceleration)	93
75	Vertical Deflection in Sponson and Skirt (Combined Acceleration)	94
76	Deformed shape for Sponson and Skirt (Combined Acceleration)	95
77	Left Sponson and Skirt FEM Model (Reinforcing Strut added at first outrigger)	96

Figure	Title	Page
78	Left Sponson and Skirt FEM Model (Reinforcing Strut added at first outrigger)	97
79	Stresses in Reinforced Sponson and Skirt (1 G Lateral)	98
80	Lateral Deflection in Reinforced Sponson and Skirt (1 G Lateral)	99
81	Stress in Reinforced Sponson and Skirt (Combined Acceleration)	100
82	Vertical Deflection in Reinforced Sponson and Skirt (Combined Acceleration)	101
83	Lateral Deflection in Reinforced Sponson and Skirt (Combined Acceleration)	102
84	Deformed shape for Reinforced Sponson and Skirt (Combined Acceleration)	103
85	Forces in outriggers and strut	104
86	CATTB Geometry - Roadwheels positions relative to spocket	108
87	CATTB Geometry - Roadwheels positions relative to C.G	109
88	CATTB Geometry - Roadwheels positions relative to C.G	110
89	CATTB Geometry - Suspension	112
90	CATTB Geometry - Track and Suspension	113
91	CATTB Geometry - Suspension Stiffness Curve	114
92	CATTB Geometry - Suspension Damping Curve	115
93	CATTB Geometry - DADS Suspension Curve	116
94	CATTB Geometry - DADS Damping Curve	117
95	CATTB Geometry - DADS Impulse Curve	118
96	CATTB Geometry - DADS ABG4 Terrain Curve	119
97	CATTB Geometry - DADS Custom Terrain Curve	120

98	CATTB Roll and Pitch Angle	121
99	Vertical Acceleration at Chassis C.G and first roadwheel	122
100	Vertical Forces in roadwheels 1, 4, and 7	124
101	Vertical Forces in roadwheels 2, 3, 5, and 6	128
104	Maximum Forces in roadwheels L1, 4, and 7 (case 1)	134
105	Maximum Forces in roadwheels L2, 3, 5, and 6 (case 1)	135
106	Maximum Forces in roadwheels R1, 4, and 7 (case 1)	136
107	Maximum Forces in roadwheels R2, 3, 5, and 6 (case 1)	137
108	Maximum Forces in roadwheels L1, 4, and 7 (case 2)	138
109	Maximum Forces in roadwheels L2, 3, 5, 6 (case 2)	139
110	Maximum Forces in roadwheels R1, 4, and 7 (case 2)	140
111	Maximum Forces in roadwheels R2, 3, 5, and 6 (case 2)	141
112	Fore - Aft gun displacement during firing	142
113	Pitch displacement during firing	143
114	Fore - Aft gun velocity during firing	144
115	Fore - Aft gun acceleration during firing	145
116	Chassis Acceleration during firing	146

117	Roadwheels reactions due to firing force	147
118	Firing force roadwheels reactions (1,4, and 7)	148
119	Firing force roadwheels reactions (2,3,5, and 6)	149
120	Fore - Aft displacement for LW gun and 120 mm gun	150
121	Pitch displacement for LW gun and 120 mm gun	151
122	Fore - Aft Acceleration for LW gun and 120 mm gun	152
123	CATTB Stress Analysis for static firing load in first roadwheel	155
124	CATTB roadwheels reactions under static firing load	156
125	CATTB Stresses due to 0.16 in vertical movement	157
126	CATTB Stresses for dynamic firing load	158
127	CATTB Stresses for dynamic firing load	159
128	CATTB Stresses for firing load and terrain load (case 1)	160
129	CATTB Stresses for firing load and terrain load (case 1)	161
130	CATTB Stresses for firing load and terrain load (case 2)	162
131	CATTB Stresses for firing load and terrain load (case 2)	163

LIST OF TABLES

1	Weight and C.G location for CATTB turret components	6
2	Mass properties for CATTB turret components about axis passing through their C.G's	7
3	Mass properties of CATTB components about axis passing through turret center of rotation	8
4	Mass properties for CATTB hull	10
5	CATTB Geometry - Mass properties	111
6	CATTB EIGEN value analysis results - frequency	164
7	CATTB EIGEN value analysis results - reaction forces	165
8	CATTB EIGEN value analysis results - nodal stresses	166

PREFACE

This report illustrates the process necessary to make structural analysis and design of tracked vehicles a systematic procedure in which state-of-the art structural analysis, design and simulation are fully utilized. It is a modest step towards understanding the behavior of tracked vehicles under various loading conditions. It will be a good starting point in any subsequent research in this area. For this reason, the various results and the approach utilized were presented chronologically to keep the reader continuously in touch with the changes in analysis approach, which was necessary for achieving the final results.

The rapid development in computer hardware and software technology make undertaking such a task possible, something not even thought of a few years ago. Undoubtedly, this development will allow TACOM Personnel to tap into new area of research, which will allow them to revolutionize their design and analysis process.

I would like to take this opportunity to express my appreciation for the confidence and support that Mr. Art Adlam and John Korpi have shown which allow me to dedicate myself to this investigative study. Also I would like to thank Dr. Ron Beck and Mr. Zoltan Janosi for allowing me to get hands-on training on DADS program. Also I would like to thank Mr. Ken Cerelli and Bob Garcia for their cooperation in utilizing the Finite Element Code (IRM) and Patran Software. Also I would like to thank Mr. John Weller for his support in utilizing DADS program in the Dynamic Analysis area and providing access to mathematical program (MATLAB) which was utilized in performing the necessary mathematical calculation with high accuracy and great speed.

1. Summary - In this study, the dynamic effects of terrain load, in term of stresses in Components Advanced Technology Test Bed (CATTB) Chassis, was investigated. The stresses in the chassis due to terrain load is in the range of 3,000 PSI, at which the Chassis experience a vertical acceleration of 2 at its CG. To anticipate the maximum terrain effects, either a more drastic custom-made terrain can be used (Fig. 97) instead of ABG4 (utilized in Fig 96), or the traveling speed of the CATTB could be increased from the 30 mph. For simplicity, the maximum terrain effects can be assumed to be a factor of those experienced by the chassis based on previous road tests. In any event, a follow-up stress analysis is required.

Stresses due to firing load (375,000 lb) is maximum in the turret top plate (70,000 PSI). In the trunnion, it is in the range of 40,000 PSI. Stresses in the hull is maximum when the gun is firing at 90 degrees, and it is in the range of 80,000 PSI. To maximize these stresses, only two road wheels were assumed to provide resistance against lateral movement. In real situations, all road wheels resist lateral movement in a complex interaction between the track and terrain. To understand this behavior, a separate 3D DADS analysis is required. The transient dynamic effect of gun firing force could not be performed due to software difficulties. However, the model and input file are saved for further studies in this area.

2. INTRODUCTION

The continuous advancement in technology, the introduction of the solid modelers, and the supercomputer lead to the evolution of the design process at TACOM. The old design method "shave it till it breaks" simply will not work due to the complexity of automotive structure and the forces affecting it, and because of the enormous amount of time required by such an approach. In the new evolved design, all parameters and their effects can be quantified, and better results can be achieved in a much shorter period of time. This can be accomplished by building a computer model which will serve as an inexpensive and expendable prototype. The mass properties (weight, moments of inertia and C.G location) for this prototype can be calculated easily by using the solid modeler capabilities. The forces acting on this prototype can be evaluated by performing a dynamic analysis utilizing the Dynamic Analysis and Design Software (DADS) available on the supercomputer. The strength of each component will be assured by conducting a Comprehensive Finite Element Analysis for this prototype under various loading conditions, such as firing load terrain forces, vibration, airdrop or blast, and other destructive testing. The new design will produce the best and most efficient product within the shortest span of time. In addition, it will provide understanding of the interaction of the various design parameters, which will help make any subsequent design modifications to be done with speed and confidence. The purpose of this study is to apply this systematic design approach to the design of the Components Advanced Technology Test Bed (CATTB).

3.0 Discussion - The material presented in this report represents design stages for the Component Advanced Technology Test Bed (CATTB). It is categorically divided into four stages as follows:

Solid Modeling:

In this stage, CATTB geometry for turret and hull is established, and their physical properties are evaluated.

Static Finite Element Analysis:

The configuration of the CATTB chassis was established to accommodate the new light weight gun. For this, a complete static finite element analysis was performed to assure the adequacy of the CATTB Chassis strength under various loading conditions.

Dynamic Analysis:

In this stage, a CATTB dynamic model was built and analyzed using DADS software. The forces and acceleration acting on the various components were established.

Dynamic Finite Element Stress Analysis:

A detailed finite element analysis was performed to study the dynamic nature of terrain and firing forces and the effects of vibration on CATTB structure.

The assumptions made and the results obtained for these four stages as presented in detail on the following pages.

4, Results:

The results of the four design stages are presented as follows:

4.1 CATTB Solid Model

4.1.1 Turret Solid Model:

The objective of creating a solid model for the CATTB turret is to study the effects of the new turret feature (trunnion, new gun mount and side-plate locations) on the characteristic behavior of the CATTB turret. Also, it was necessary to determine the new turret mass properties for establishing the requirement for the hydraulic system necessary to power the turret. A solid model was created on the Intergraph CAD system utilizing EMS software. This model was created from a series of primitive solids (cubes Tetrahedron.....) because changing dimensions length, height, and width can be achieved quite easily by lifting the faces or edges of these primitive solids. turret geometry is shown in Fig (1 - 3), turret solid model is shown in Fig (4 - 8).

4.1.2 Evaluation of CATTB Turret Mass Properties:

The powerful capabilities of the CAD system were utilized to evaluate CATTB mass properties. These properties, which include weight, CG locations, and moments of inertias for the CATTB turret's various components, are shown in Appendix A. Total CATTB turret weight and the location of its C.G were determined mathematically as, shown in Table 1. CATTB mass properties at about any point can be determined by transforming mass properties of the various components from their own CG to that given point as shown in Table 2 & 3.

Plate thickness for CATTB turret structure is shown in Fig (1) side-armor thickness is 40 inches in the front area and projected through proper angles to both sides. The density of side armor used is 0.095 lb/in^3 and is based on 550 lb/ft^2 . For 50" armor, the density is 0.104 lb/in^3 and is based on 750 lb/ft^2 .

Top-armor thickness used is 4 inches, except over the L.W. 120mm gun front area, where it is 2 inches. At the rear gun area, no top armor is used. The density of the top armor is 0.1215 lb/in^3 and is based on 70 lbs. per square ft. for 4 inches thick.

Spall liner is used on the inside of the CATTB Turret crew area. At thickness of one inch, the density of the spall liner used is 0.04 lb/in^3 and is based on weight of 5.7 lb. per square ft.

To convert mass properties from lbs. - in² to slug - ft² (lbs. - ft - sec²), the following multiplication factor was used:

$$\frac{1}{32.2} \times \frac{1}{12} \times \frac{1}{12}$$

= 0.0002157 or 2.157 x 10⁻⁴

4.1.3 HULL Solid Model:

CATTB solid model for the hull and suspension are shown in Fig (9 - 11). The basic hull structure, skirts, spansons, grills and suspension (idler, roadarms, roadwheels and final drive) were created as solids. Whereas, the power pack, fuel tank, autoloader, and various electrical control boxes were not modeled as a solid, but primitive solids were used to represent their Geometry.

4.1.4 HULL Mass Properties:

The mass properties of the various hull components about their own CG was calculated using EMS software and are shown in detail in Appendix B. The hull CG was found and hull mass properties about the axis, passing through its CG was obtained by transforming mass properties of the various hull components to the hull CG location, as shown in Table 4.

Table 1 Weight and C.G Location for CATTE Turret Components

COMPONENT	WEIGHT M (lbs)	C.G LOCATION			(IN) Z	FIRST MOMENTS (lbs - in)		
		X	Y			MX	MY	MZ
(2):	10,000	-90.4	0	17.0	-913,040	0	171,700	
GUN (1)	6,810	-67.8	0	17.0	-461,718	0	115,770	
SIDE ARMOR(40")	15,770	-26.7	+ 0.6	18.0	-421,060	- 9,460	283,860	
(50")	24,150	-29.5	- 0.5	18.4	-712,430	-12,080	444,360	
TOP ARMOR	2,900	14.0	0.3	42.0	40,600	870.0	121,800	
SPALL LINER	1,250	18.0	0.3	26.0	22,500	375.0	32,500	
BASKET	830	- 2.6	0.7	-32.5	- 2,158	581.0	-26,975	
COM'DR CHAIR	160	18.4	-25.0	- 9.5	2,944	- 4,000	- 1,520	
GUN CHAIR	180	12.0	25.8	-16.5	2,160	4,644	- 2,970	
GUN HATCH	120	12.0	14.3	38.3	1,440	1,716	4,596	
WEAPON ST	860	20.6	-23.6	40.3	17,716	-20,296	34,658	
GEAR BOX	570	-23.4	27.3	4.4	-13,338	15,561	2,508	
AUTO LOADER	3,650	90.6	- 0.8	24.50	330,690	- 2,920	89,425	
BASIC STRUCTURE	13,560	54.7	- 0.7	21.0	741,730	- 9,490	284,700	
TOP PLATE	3,650	47.1	0.4	37.4				
BOTTOM PLATE	4,340	56.4	- 0.1	5.9				
VERTICAL PLATE (Crew Area)	2,885	18.7	- 3.4	19.4				
VERTICAL PLATE (Bustle Area)	2,685	101.0	- 0.4	24.7				
BEARING	265	0	0	- 1.50	0	0	- 398	
GUN SHIELD	210	-48.5	0.2	16.70	- 10,185	- 42	351	
ELECTRICAL BOXES	900	- 2.5	0.4	16.70	- 2,250	360	-15,030	
GPS & MTAS	630	17.70	29.5	39.00	11,150	18,585	24,570	
SIGNATURE SUPP SKIN	750	-25.0	0	18.50	- 18,750	0	13,875	
TOTAL(40" Armor)	49,415	4.80	- 0.07	19.50	241,471	- 3,516	961,720	
(1) (50" Armor)	57,795	- 0.86	- 0.11	19.40	- 49,900	- 6,136	1,122,220	
(2) 40" (Armor)	52,700	-4.0	-0.05	19.3	-209,850	-3,516	1,017,650	
50" (Armor)	61,000	-8.2	-0.10	20.3	-501,220	-6,136	1,234,080	
(1) Provided by Gun Manufacturer								
(2) Calculated Using EMS								

Table 2: Mass Properties of CATB Turret
 Components About Axis Passing Through Their C.G's

<u>COMPONENTS</u>	<u>I x (lb - in²)</u>	<u>I y (lb - in²)</u>	<u>I z (lb - in²)</u>
GUN (1)	172,116	30,965,700	30,965,300
(2)	490,880	59,680,700	59,680,700
SIDE ARMOR(40")	31,060,200	17,704,900	46,325,900
(50")	53,873,400	30,777,100	80,912,900
TOP ARMOR	1,731,330	1,611,100	3,914,860
SPALL LINER	1,333,180	1,180,060	2,188,140
BASKET	456,150	404,680	771,670
COM'D CHAIR	38,790	40,260	6,860
GUN'R CHAIR	9,770	11,750	7,460
GUN'R HATCH	7,370	4,440	11,590
WEAPON STATION	90,740	85,660	172,140
GEAR BOX	33,820	26,980	25,080
AUTOMATIC LOADER	2,124,560	1,202,440	3,032,340
BASIC STRUCTURE	13,976,550	20,823,640	33,667,790
TOP PLATE	2,206,820	7,791,350	9,987,530
BOTTOM PLATE	3,542,470	8,690,130	11,997,000
VERTICAL PLATE (Crew Area)	4,174,550	3,013,540	6,607,190
VERTICAL PLATE (Bustle Area)	4,052,710	1,328,620	5,076,070
BEARING	158,365	158,365	316,330
GUN SHIELD	16,930	10,880	12,575
ELECTICAL BOXES	360,405	373,095	661,745
GPS & MTS	41,820	287,635	276,595
SIGNATURE SUPP SKIN	238,875	47,670	286,540

Table 3 Mass Properties of CAITB Components About Axis Passing Through Its Center of Rotation

COMPONENT	I_x (lb - in ²)	I_y (lb - in ²)	I_z (lb - in ²)
GUN (1)	2,133,500	64,252,400	62,290,000
(2)	3,409,780	145,138,420	142,219,520
SIDE ARMOR (40")	36,220,700	34,089,700	57,560,700
(50")	62,060,700	59,950,100	101,912,000
TOP ARMOR	6,854,600	7,315,600	4,496,440
SPALL LINER	2,187,400	2,438,800	2,592,830
BASKET	1,340,000	1,293,900	777,900
COM'DR CHAIR	152,300	103,960	165,890
GUN CHAIR	183,930	89,486	157,880
GUN HATCH	245,560	191,030	96,780
WEAPON STATION	1,978,800	1,856,800	1,025,180
GEAR BOX	66,780	57,815	44,240
AUTOMATIC LOADER	4,320,000	33,417,000	33,056,000
BASIC STRUCTURE	21,989,340	79,068,730	83,967,880
TOP PLATE	7,314,150	20,999,400	18,089,100
BOTTOM PLATE	3,692,880	22,633,300	25,789,800
VERTICAL PLATES (Crew Area)	5,297,430	5,116,830	7,653,480
VERTICAL PLATE (Bustle Area)	5,684,880	30,319,200	32,435,500
BEARING	158,365	158,365	316,330
GUN SHIELD	74,510	553,560	497,690
ELECTRICAL BOXES	611,180	629,115	667,250
GPS & MTAS	1,541,730	1,436,130	1,021,740
SIGNATURE SUPP SKIN	2,189,625	516,425	2,706,050
TOTAL (40" Armor) (lb - in ²) (50" Armor)	82,248,320 108,088,320	227,468,816 253,329,216	251,440,780 295,792,080
TOTAL (40" Armor) (1) (Slug - ft ²) (50" Armor)	17,741 23,315	49,065 54,643	54,236 63,802
TOTAL (40" Armor) (2) SLUG-FT ² (50" Armor)	18,013 23,586	66,526 72,103	71,465 81,030

Moment of Inertia of CATTB Turret About Axis
Passing Through its C.G

$$I x_o = I x - (\bar{y}^2 + \bar{z}^2) M$$

$$I y_o = I y - (\bar{x}^2 + \bar{z}^2) M$$

$$I z_o = I z - (\bar{x}^2 + \bar{y}^2) M$$

Where $I x$, $I y$, and $I z$ are moment of inertia about turret rotational center (table 4). x , y , z and M are given in table 2.

Using the above equations

$$\begin{aligned} I x_o &= 82,248,320 - (19.50^2 + 0.07^2) \times 49,415 \\ &= 82,248,320 - 18,790,300 \\ &= 63,458,020 \text{ lb} - \text{in}^2 \\ &= 13,688 \text{ slug} - \text{ft}^2 \text{ (x } 0.2157 \times 10^3 \text{)} \end{aligned}$$

$$\begin{aligned} I y_o &= 227,468,820 - (4.8^2 + 19.50^2) \times 49,415 \\ &= 227,468,820 - 19,928,580 \\ &= 207,540,240 \text{ lbs} - \text{in}^2 \\ &= 44,766 \text{ slug} - \text{ft}^2 \end{aligned}$$

$$\begin{aligned} I z_o &= 251,440,780 - (4.8^2 + 0.07^2) \times 49,415 \\ &= 251,440,780 - 1,138,760 \\ &= 250,302,020 \text{ lbs} - \text{in}^2 \\ &= 53,990 \text{ slug} - \text{ft}^2 \end{aligned}$$

TABLE 4

MASS PROPERTIES FOR CATTB HULL

COMPONENT	WEIGHT (LBS)	C.G. LOCATION (IN)			MOMENT OF INERTIA ABOUT COMPONENT C.G.X10 ⁶			MASS PROPERTIES ABOUT HULL C.G.X10 ⁶		
		X	Y	Z	Ix	Iy	Iz	Ix	Iy	Iz
BASIC STRUCTURE	23815	-3.10	0.86	-24.3	28.83	172.28	191.9	29.0	201.6	221.4
SKIRT	1320	22.6	0.12	-23.0	5.8	8.8	14.5	5.82	8.96	14.61
SPANSON	4900	56.0	0	-6.3	14.3	25.6	39.8	15.96	30.10	42.61
GILLS	3920	123.30	0	0.21	2.3	5.0	7.0	4.66	40.00	39.6
FRONT ARMOR	4050	-116.9	0.53	-24.7	2.43	0.41	2.53	2.44	90.46	92.60
POWER PACK	10523	124.6	0	-24.9	6.88	4.10	8.58	6.9	94.3	98.8
MAGAZINE	3600	69.3	0	-26.3	2.32	1.28	2.83	2.34	6.3	7.84
FUEL TANK	1500	-80.9	30.4	-24.6	0.17	0.35	0.28	1.66	19.4	20.8
ELEC CONTROL EQUIPT	390	-80.8	30	-25.2	0.05	0.09	0.07	0.37	5.10	5.40
DRIVER	315	-80.8	0.4	-24.6	0.04	0.07	0.06	0.04	4.1	4.10
IDLER	335 X 2	-111.0	0	-25.7	0.03	0.03	0.024	0.68	13.70	14.32
FINAL DR	1780 X 2	143.7	0	-29.1	0.03	0.15	0.30	4.96	44.86	49.52
ROAD ARMS	3870 X 2	9.6	0	-39.2	0.38	32.00	32.00	10.26	37.38	43.86
ROAD WHEELS	1390 X 2	19.6	0	-45.2	0.16	11.20	11.20	13.84	28.84	36.92
TRACK	8900	14.6	0	-29.0	-	-	-	32.25	68.47	93.27
TOTAL	77,990	31.66	-1.2	-24.61	LB - IN ²	× (10 ⁶)		131.18	693.57	787.57
					SLUG - IN ²			339,490	1,794,950	2,033,05

TITLE: RACE RING SUPPORT AND BASE PLATES LAYOUT
DRAWN BY: D. LACAP
DATE: 15 NOV 88
SCALE: 1/16

NOTES:

- ① 1.00 THICK.
- ② 1.50 THICK.
- ③ .25 THICK.
- ④ .375 THICK.

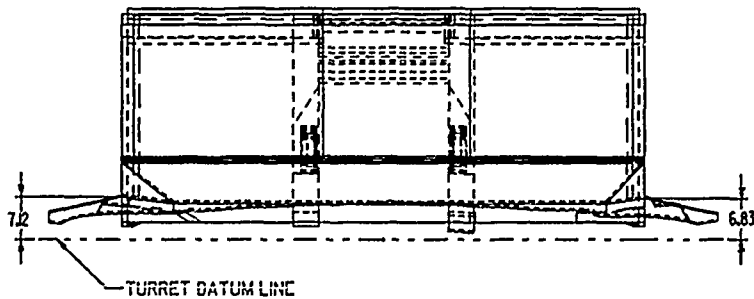
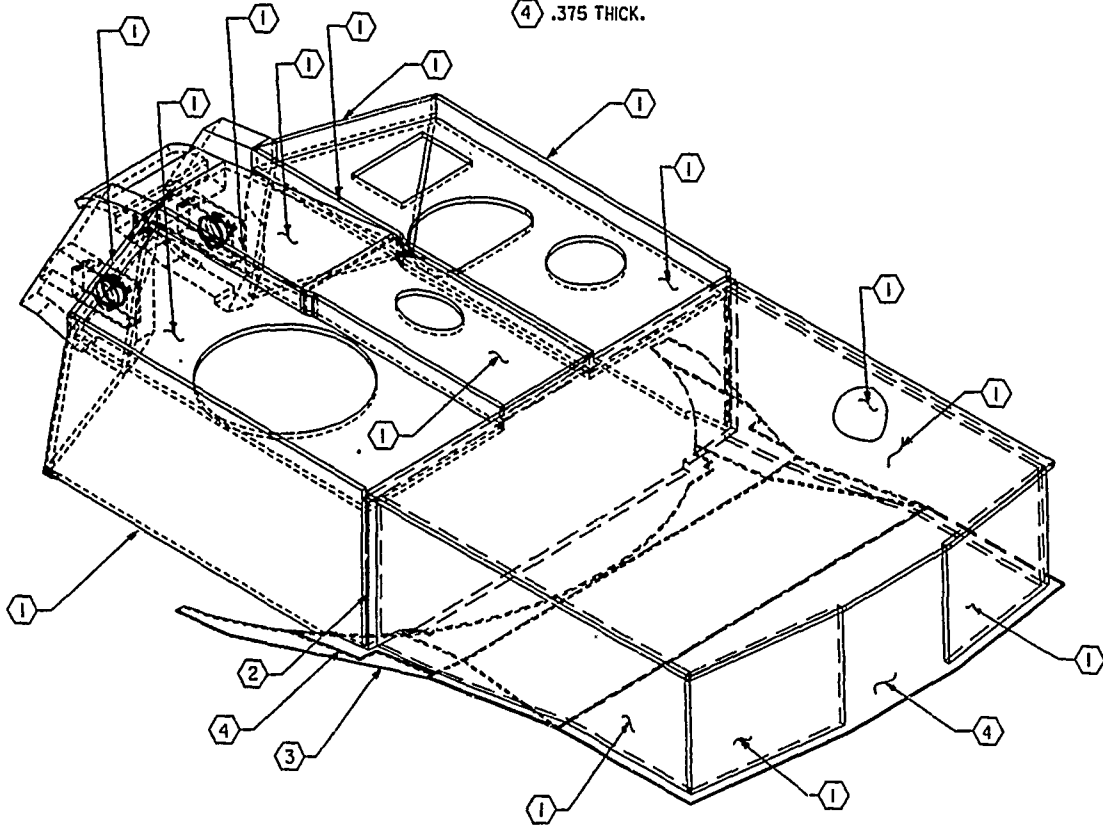

FIG 1
TURRET GEOMETRY
11

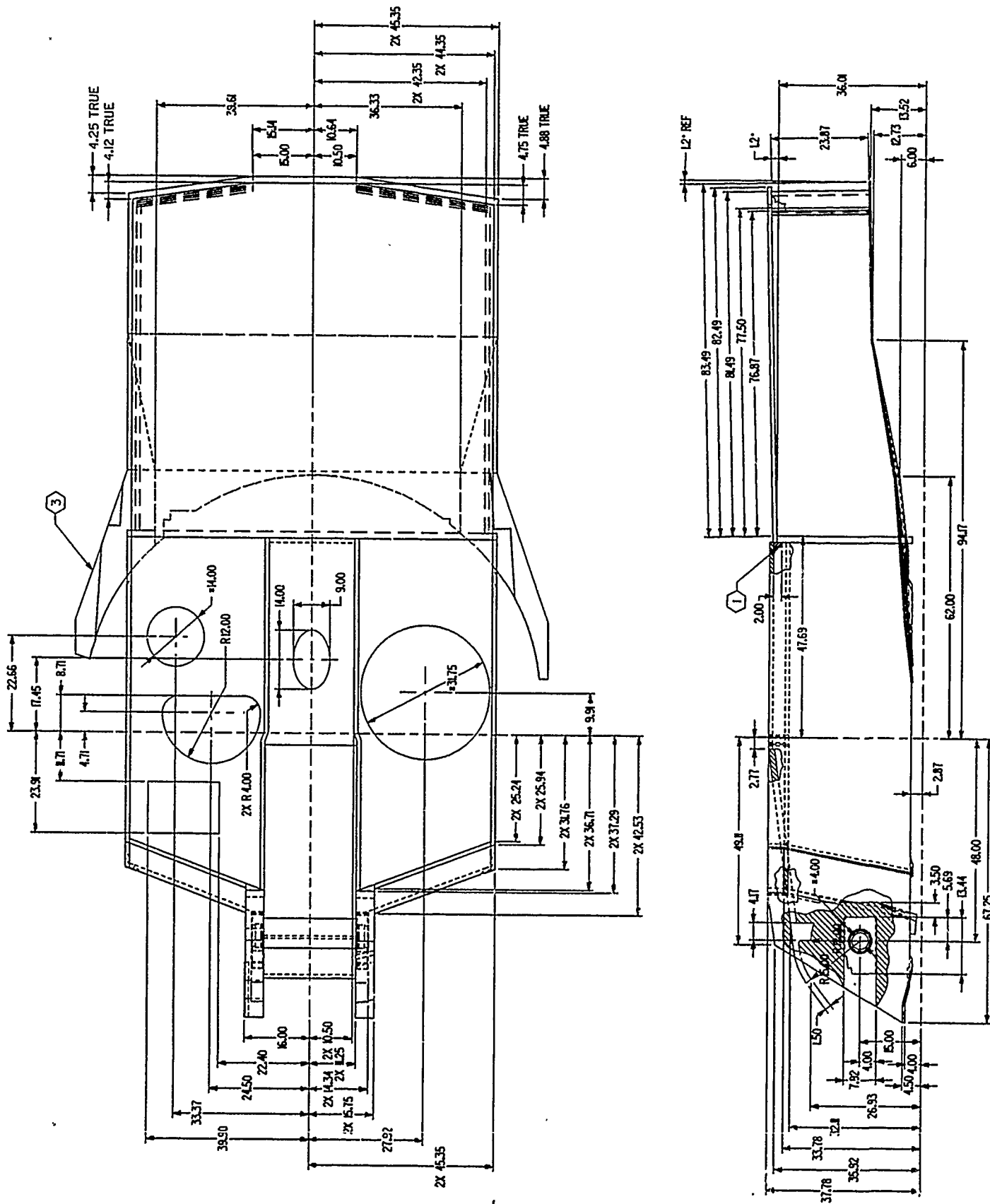

FIG 2
 TURRET GEOMETRY
 12

ADVANCED TECHNOLOGY TRANSITION DEMONSTRATOR (TURRET)

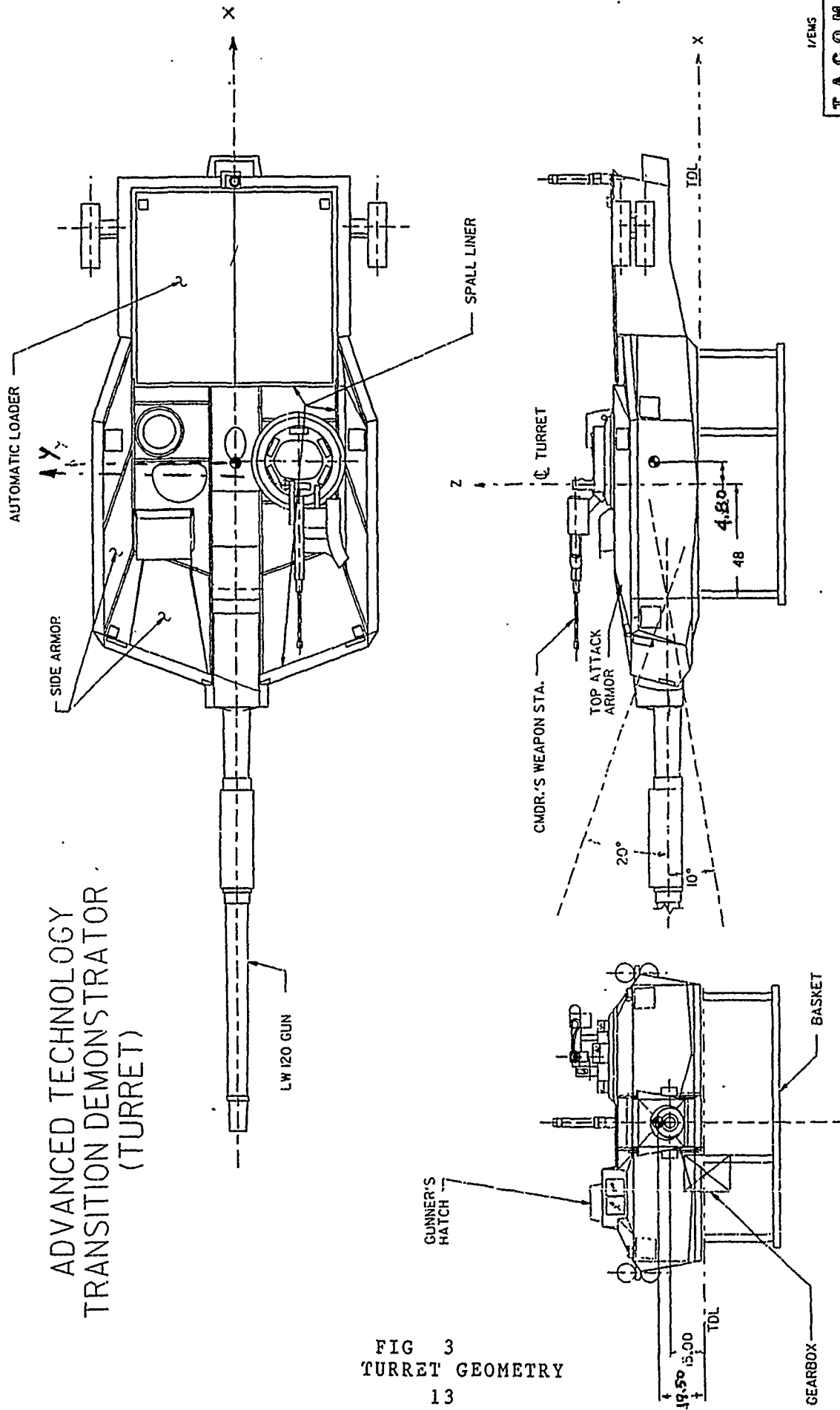

FIG 3
TURRET GEOMETRY
13

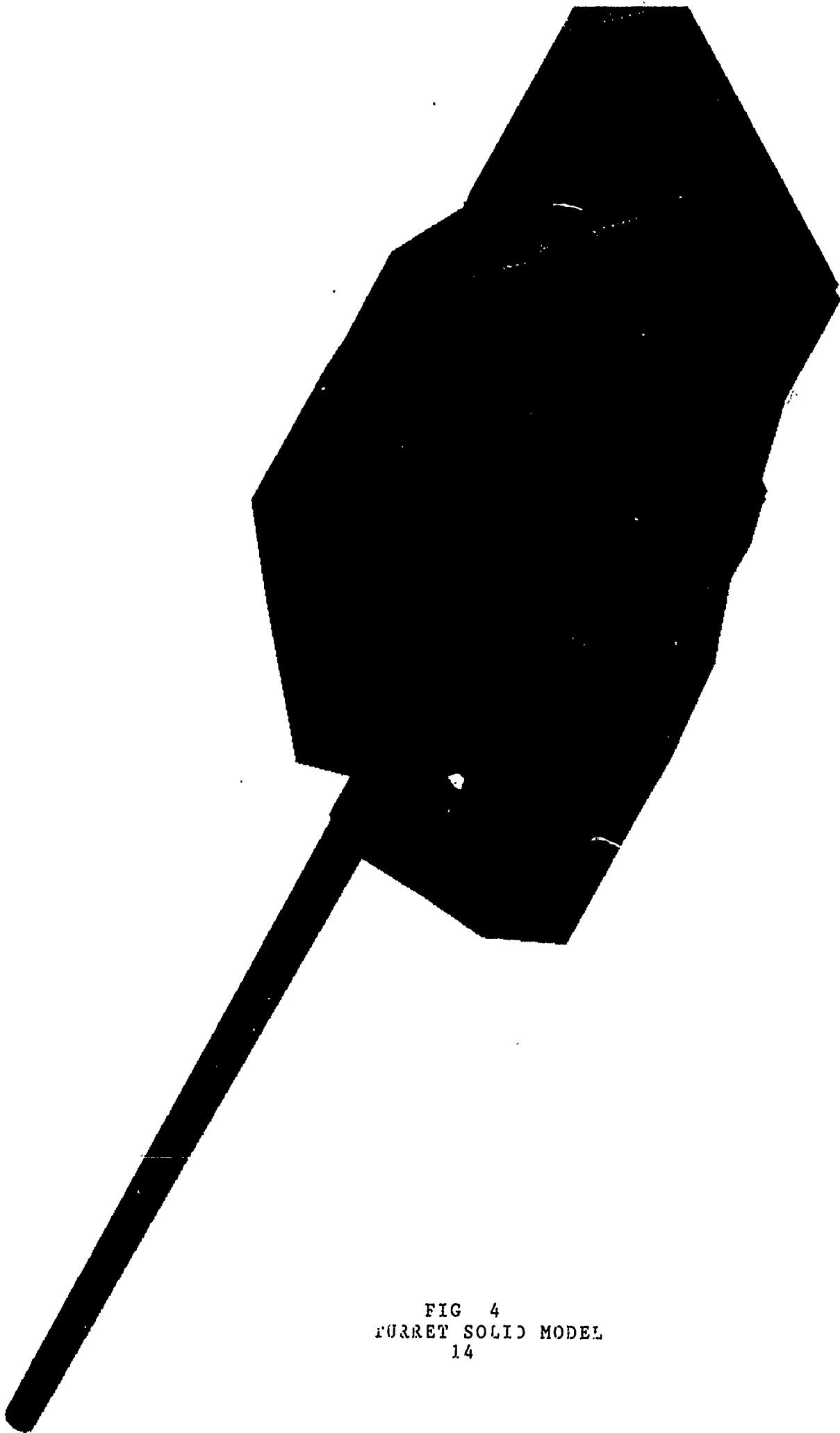

FIG 4
FURRET SOLID MODEL
14

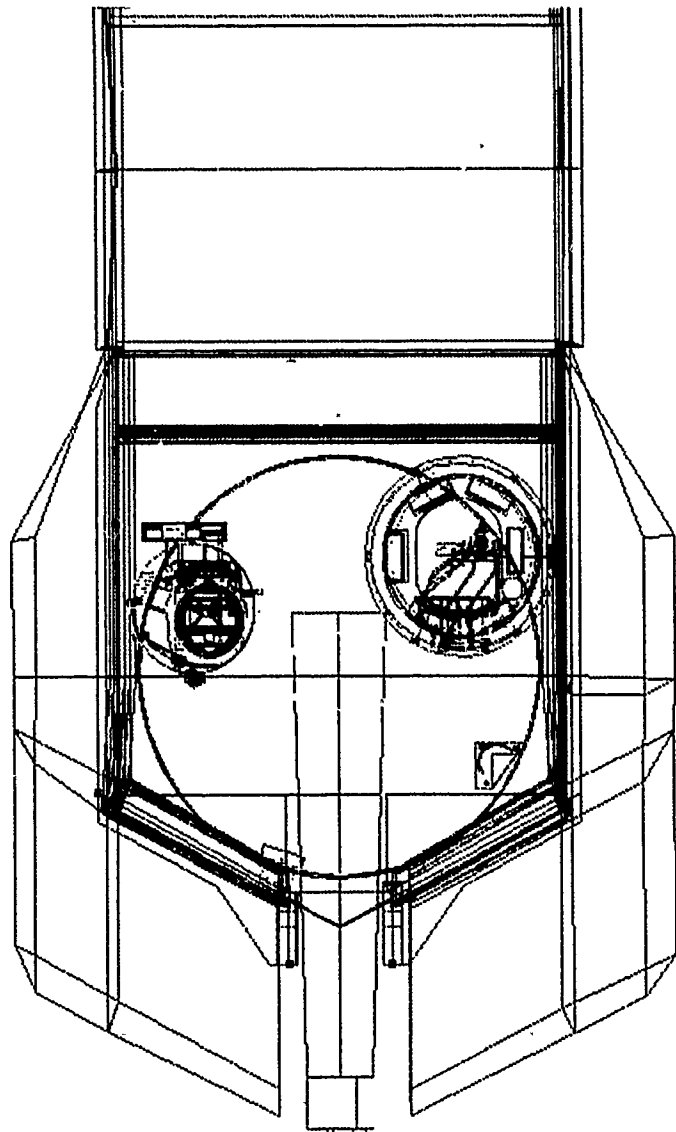

FIG 5
TURRET SOLID MODEL
15

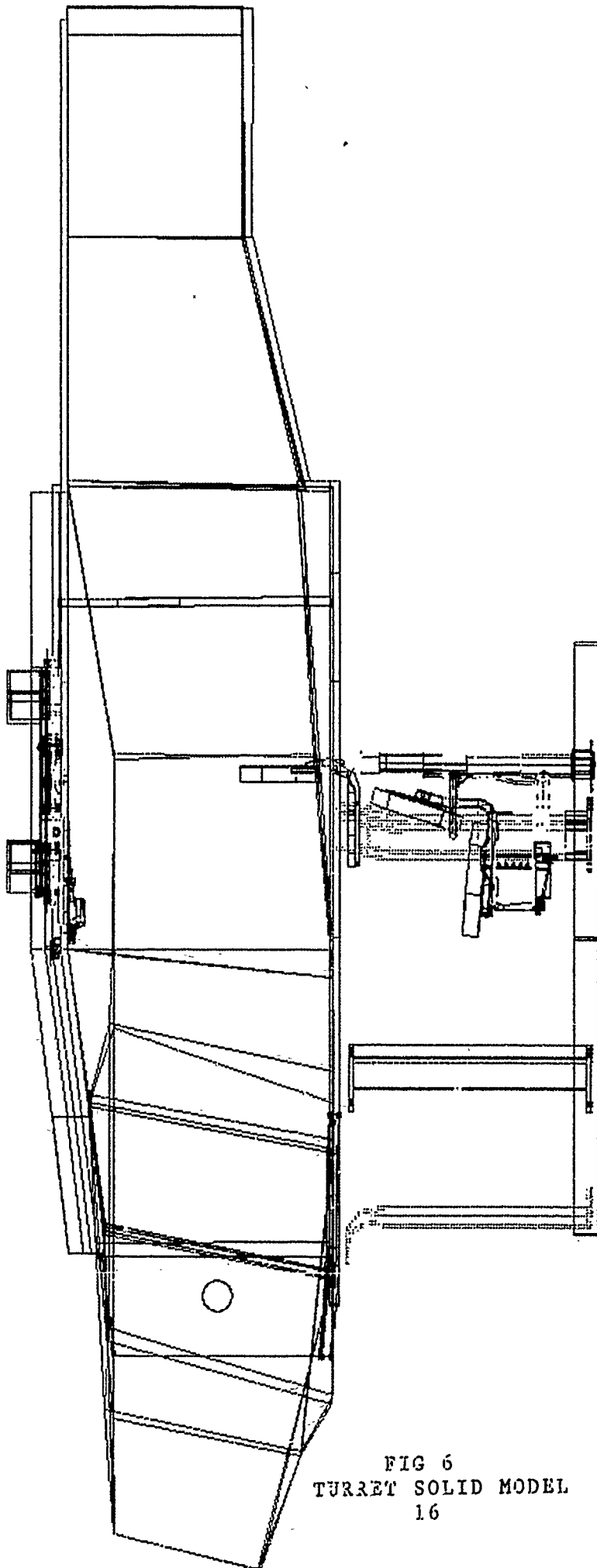

FIG 6
TURRET SOLID MODEL
16

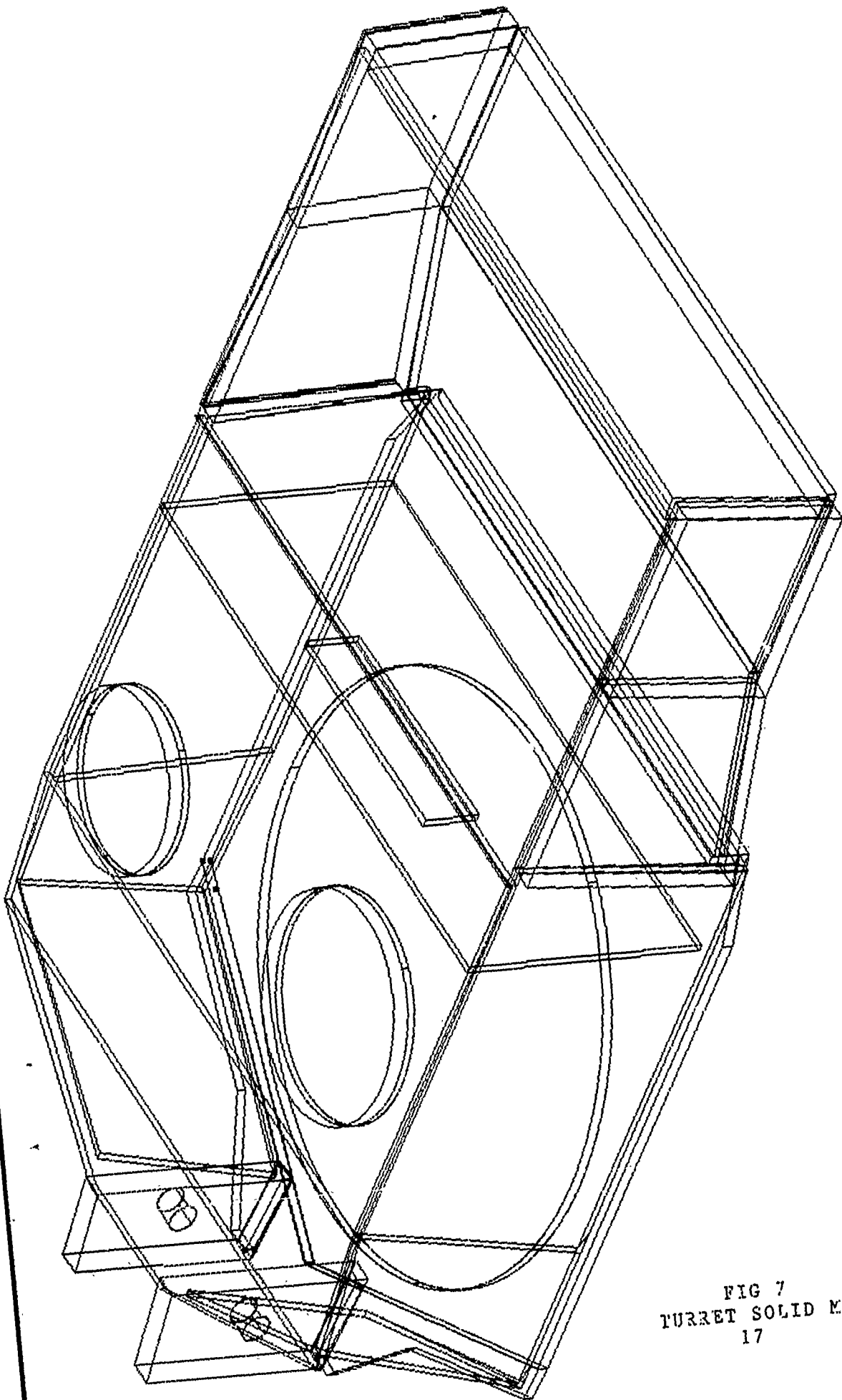

FIG 7
TURRET SOLID MODEL
17

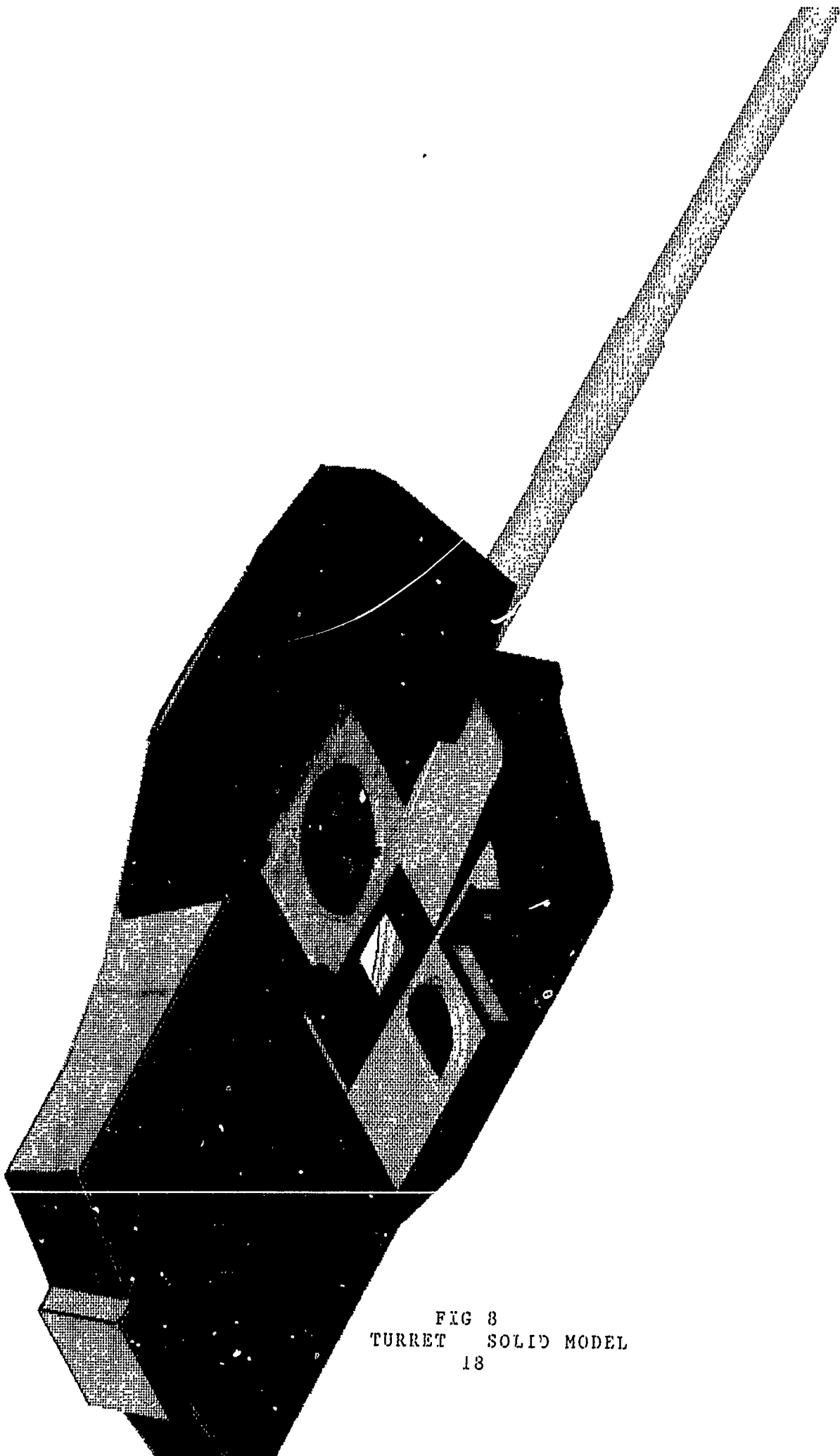

FIG 8
TURRET SOLID MODEL
18

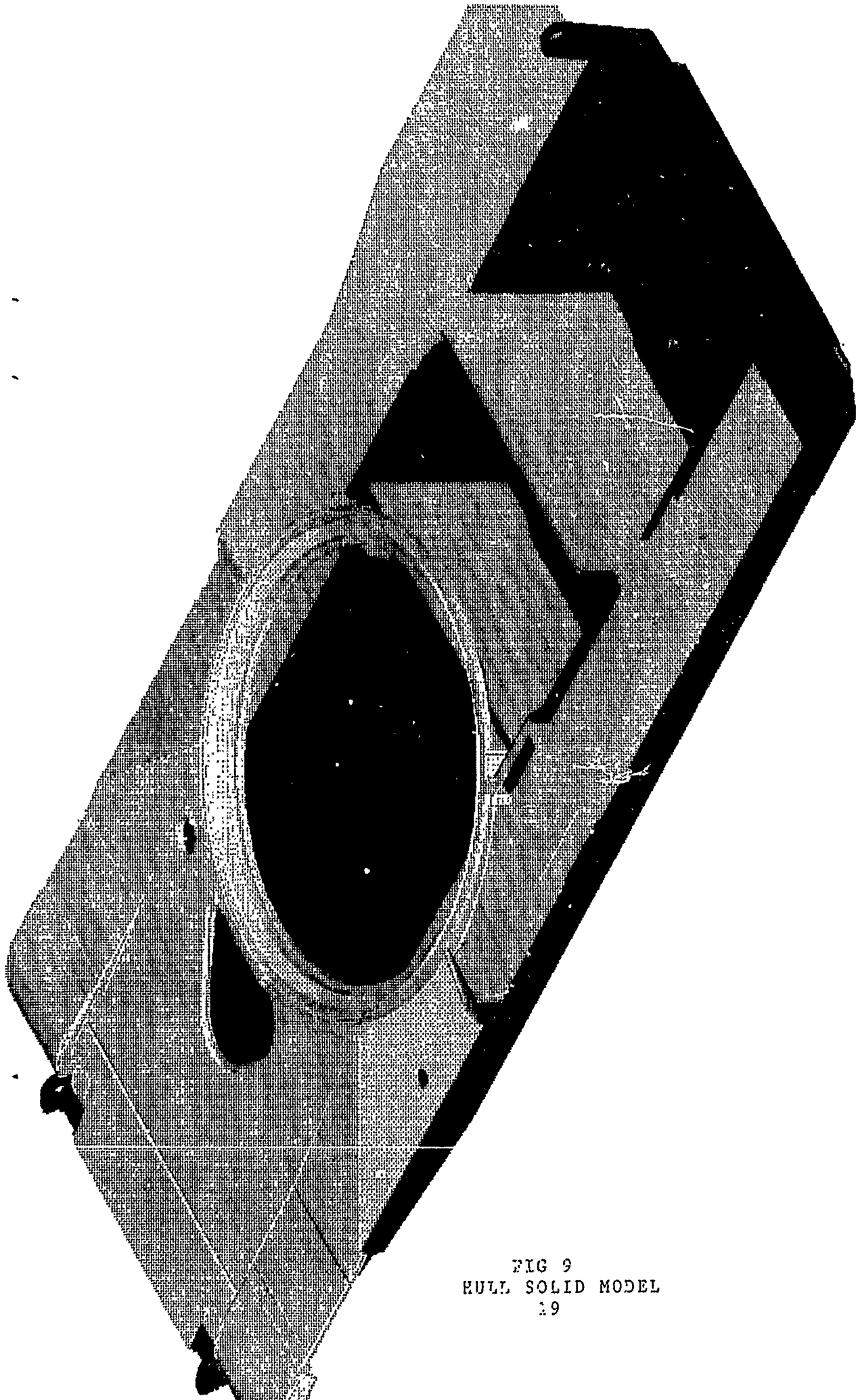

FIG 9
HULL SOLID MODEL
19

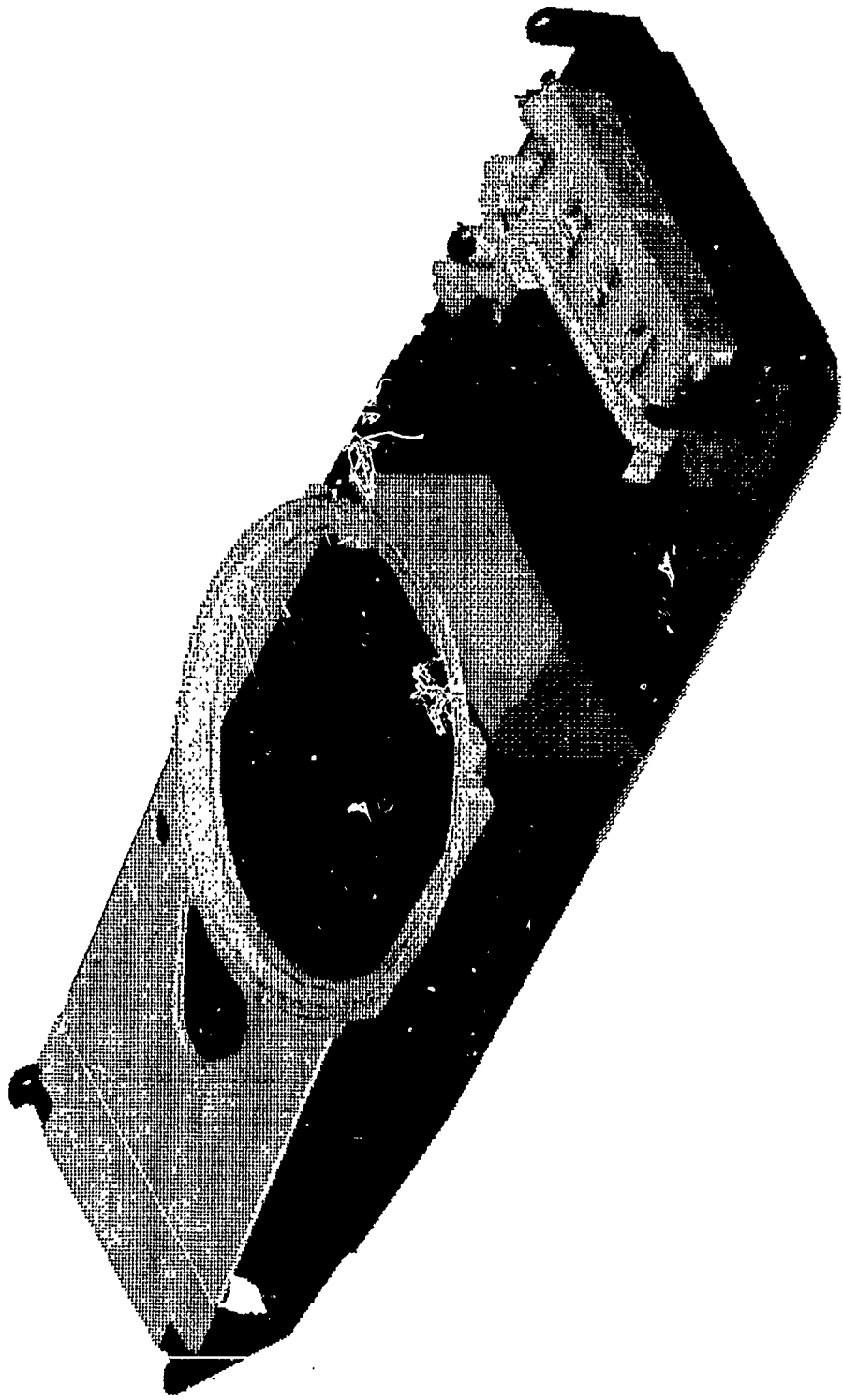
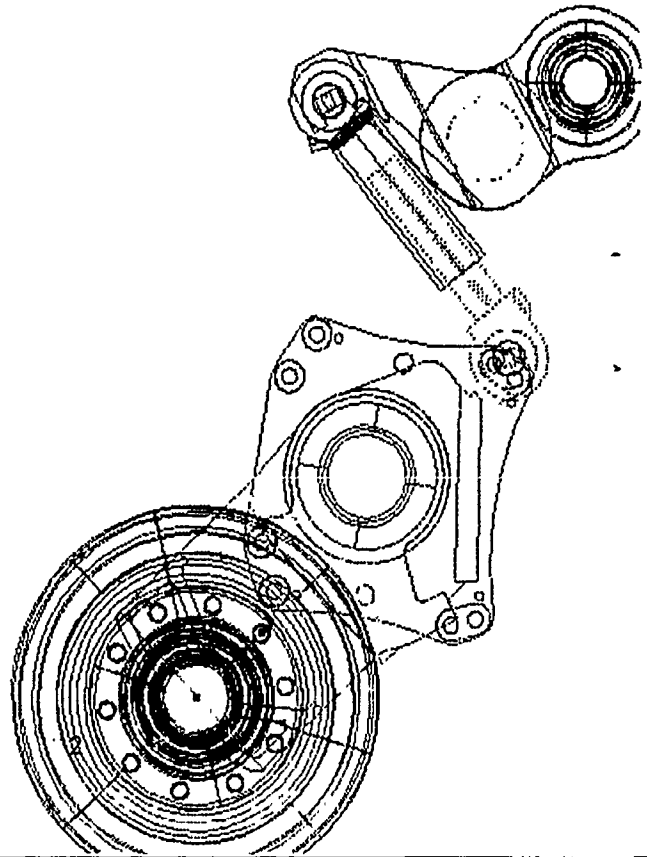
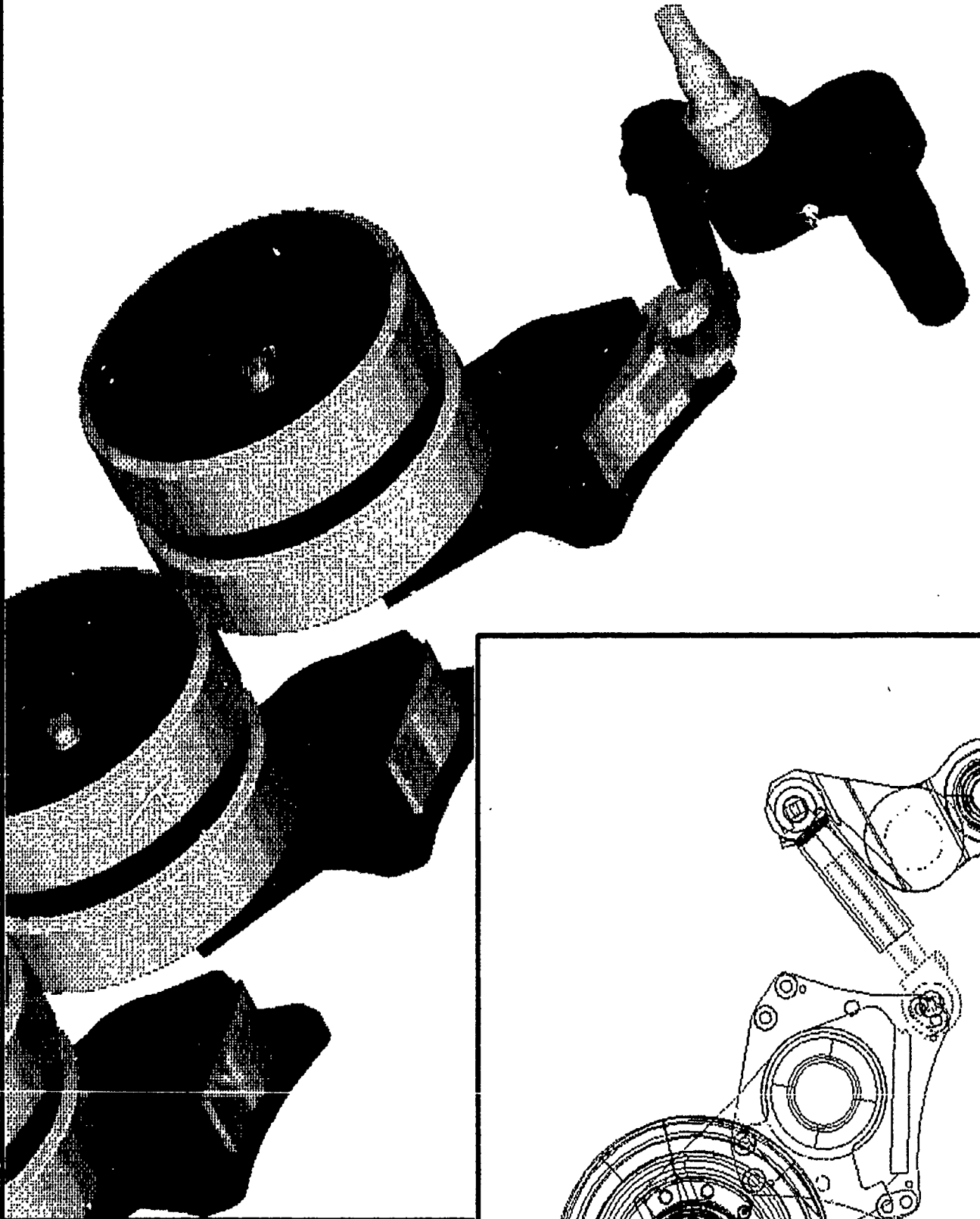

FIG 10
HULL SOLID MODEL
20



FIG 11
HIII.I. SOL.I.D MODIFI.

FIG 12
SUSPENSION SOLID MODEL



4.2 Static Finite Element Analysis

A Finite Element Model for the CATTB chassis was created utilizing Intergraph Randmicas Finite Element software (IRM). The FEM Turret Model was built first. Afterwards, the hull was modeled, and the two models were merged together to form the CATTB chassis model.

4.2.1 Turret Model:

The CATTB turret is unique in its geometry, specifically in the location of the side plates and the manner in which the gun mount interfaces with the Trunnion. To study the impact of this new geometry on turret behavior, it was necessary to build a Finite Element Model for the turret and analyze it under various loading conditions. Since a 3D solid model was available on the Intergraph CAD System, a wire frame was constructed from this 3D model and transferred to the VAX Computer, after it has been translated to IGDS, which is the graphic base for IRM. This wire frame will serve as a skeleton on which the Finite Element Model will be built.

The Turret FEM model consists of 132 four-noded shell elements. Each node has six degrees of freedom, three translations and three rotations about the global axis x, y, and z. The thickness of the various plates forming the FEM model are shown in Fig (1). The turret is fastened to the hull by a ring which has 48 mounting bolts. To reflect this geometry in the FEM model, the turret is assumed to be supported at 48 nodes, as shown in Fig (18). The turret FEM model will be used as a prototype to study the effect of the new trunnion design in comparison with the conventional one Fig (13), As a result of this study, the trunnion will be reshaped Fig (16 and 17).

4.2.2 Turret Loads

The following design loads are applied on the FEM Model:

2G (turret's own weight)
3000 lb (weight of the AutoLoader)
375,000 lb (Gun Firing wad at -10 degree or +15 degree)

To study the compounding effect of this load, two load combinations were considered:

2G (Down) + AutoLoader + Firing at -10 degree case(5)
2G (Down) + AutoLoader + Firing at 15 degree case(6)

4.2.3 Turret Analysis Results - (turret is independent)

4.2.3.1 IRM Results

VON mise stresses (which reflect bending and shear effects about the three major axis) are in the 70,000 PSI range, as shown in Fig (14). The vertical deformations are shown in Fig (15). Reshaping the trunnion area resulted in a more refined model. For the turret, as shown in Fig (16 & 17), VON mise stresses in this refined model is 44,000 PSI and occurs around the slot provided for the gun mounting block, as shown in Fig (19 & 20), this area is shown in detail in Fig (21). Maximum vertical deflection is 0.07 inch, as shown in Fig (22). The forces in the 48 mounting bolts are tabulated in Appendix C.

4.2.3.2 NISA Results

Since the CATTB Chassis FEM Model had to be made available on the Cray Supercomputer (to conduct Dynamic stress analysis, as will be shown in section 4.4), a stress analysis for the turret was conducted using NISA software. The results are shown in Fig (23 & 24). Comparing NISA results, with IRM results which is shown in Fig (19 & 20), indicates that NISA yields higher stresses in the top plate around hatch openings (76,000 PSI vs 45,000 PSI). This is primarily due to the inherent difference of stress and strain formulas in each code. NISA results are more accurate, since stress in the top plate are expected to increase due to the reduction of the resisting area.

4.2.4 Turret Analysis Results (Turret as part of Chassis):

It was found necessary when analyzing the hull to merge the turret and hull models and study their interaction effects (section 4.2.11). This provides the following actual stresses in the turret.

4.2.4.1 IRM Results

VON mise stresses are in the range of 36,000 PSI, as shown in Fig (25 & 26)

4.2.4.2 NISA Results

VON mises stresses are in the 67,000 PSI range, as shown in Fig (27). Comparison of the results (4.2.3.1) and (4.2.3.2) indicate that analyzing the turret independently from the hull yield higher stresses, because support points are considered as rigid. In contrast, when this support is considered flexible (has relative movement), it yields lower stresses. The latter are the actual results which reflect turret-hull interaction.

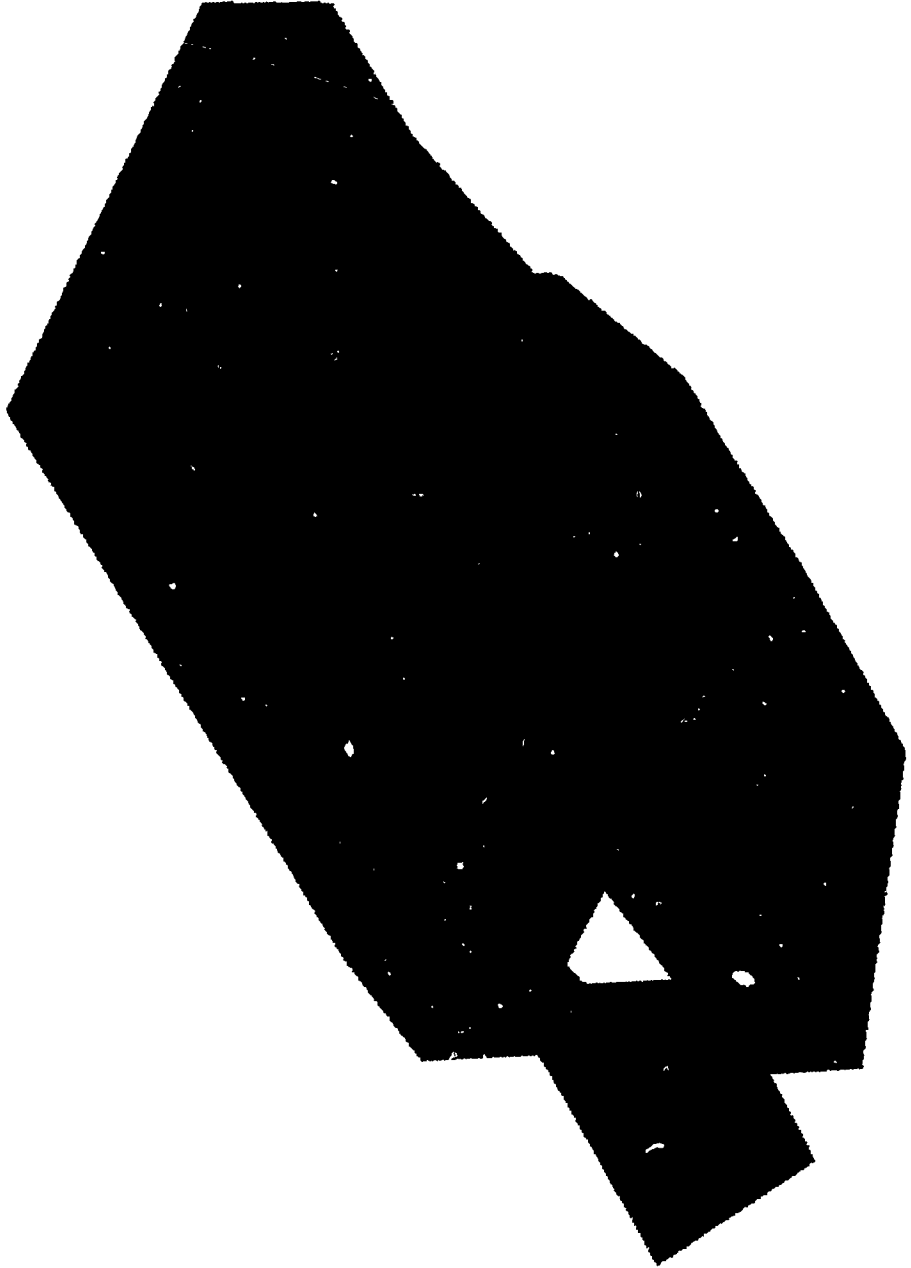
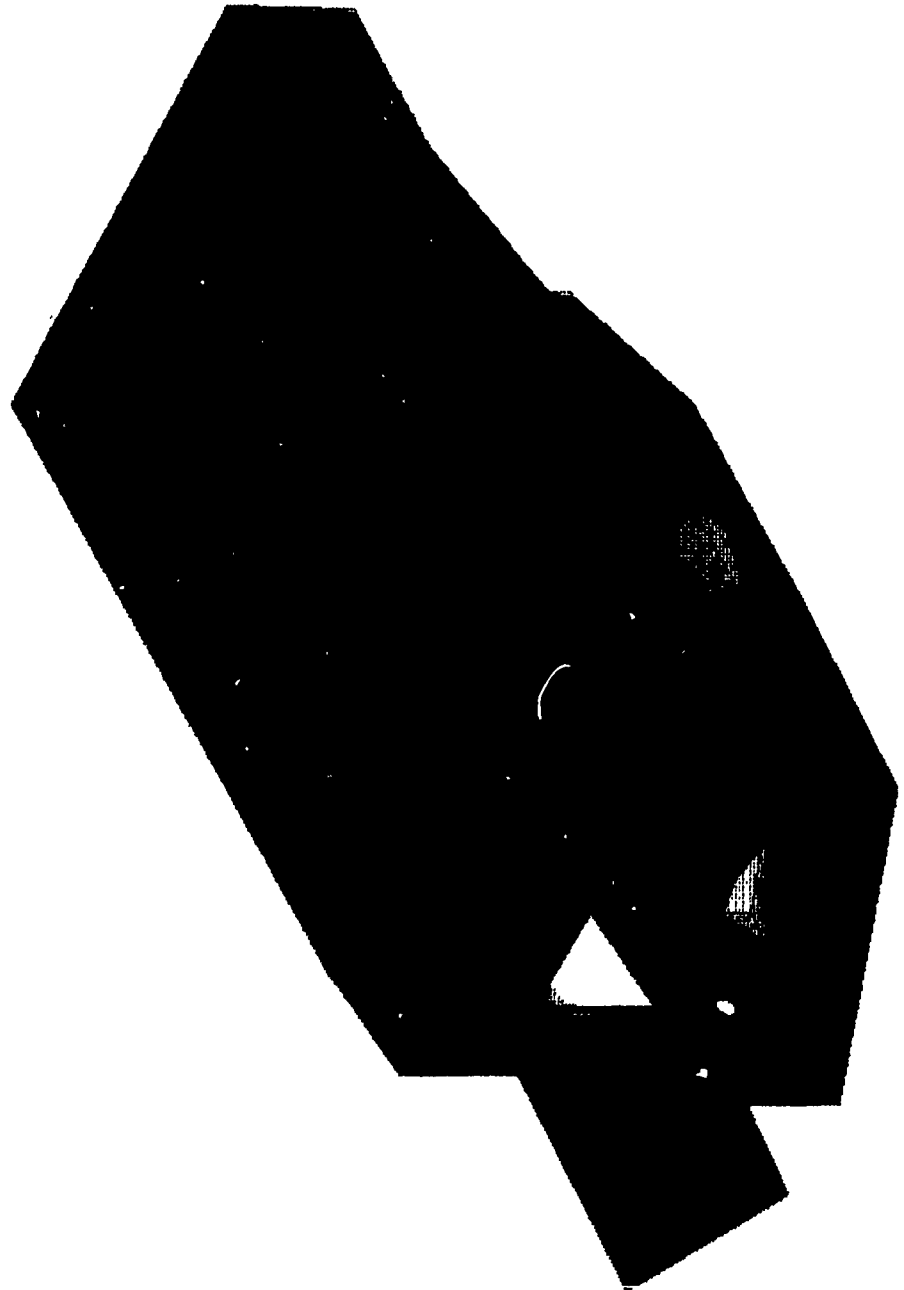

FIG 13
CATTB TURRET (CONVENTIONAL TRUNNION)

■	7.24E-04
■	7.22E-04
■	6.86E-04
■	6.50E-04
■	6.14E-04
■	5.78E-04
■	5.42E-04
■	5.06E-04
■	4.70E-04
■	4.34E-04
■	3.98E-04

■	2.52E-04
■	2.16E-04
■	1.80E-04
■	1.44E-04
■	1.08E-04
■	7.2E-05
■	3.6E-05



COMB5=INTOP

FIG 14
STRESS IN CATTB (CONVENTIONAL TRUNNION)

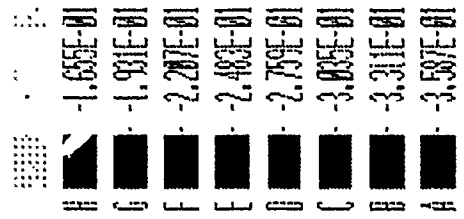
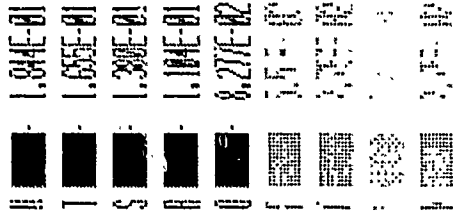

COMPS 02
 2-01SP - COMPS

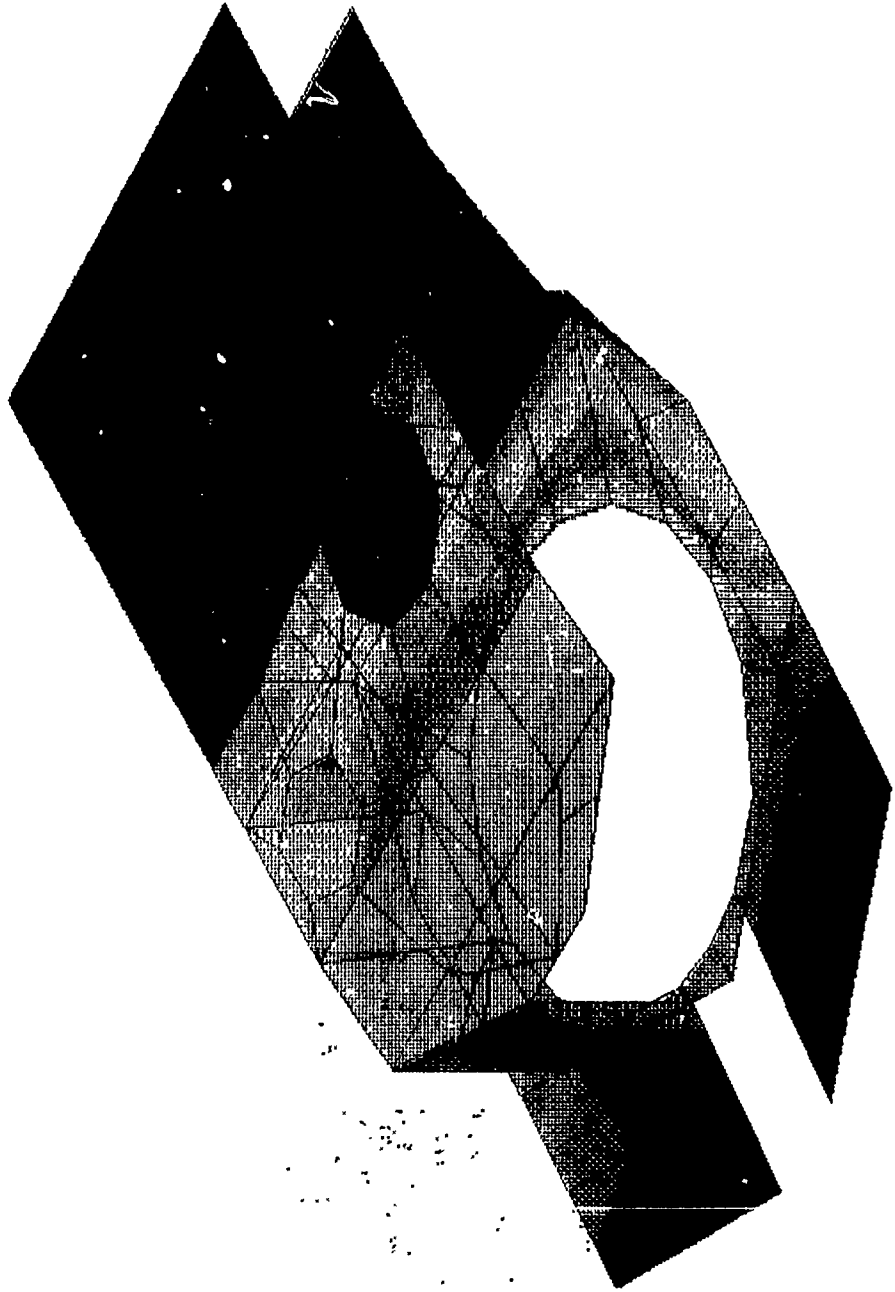

FIG 15
 DEFLECTION IN CATTB (CONVENTIONAL TRUNNION)



FIG 16 - CATTB TURRET (NEW TRUNNION)

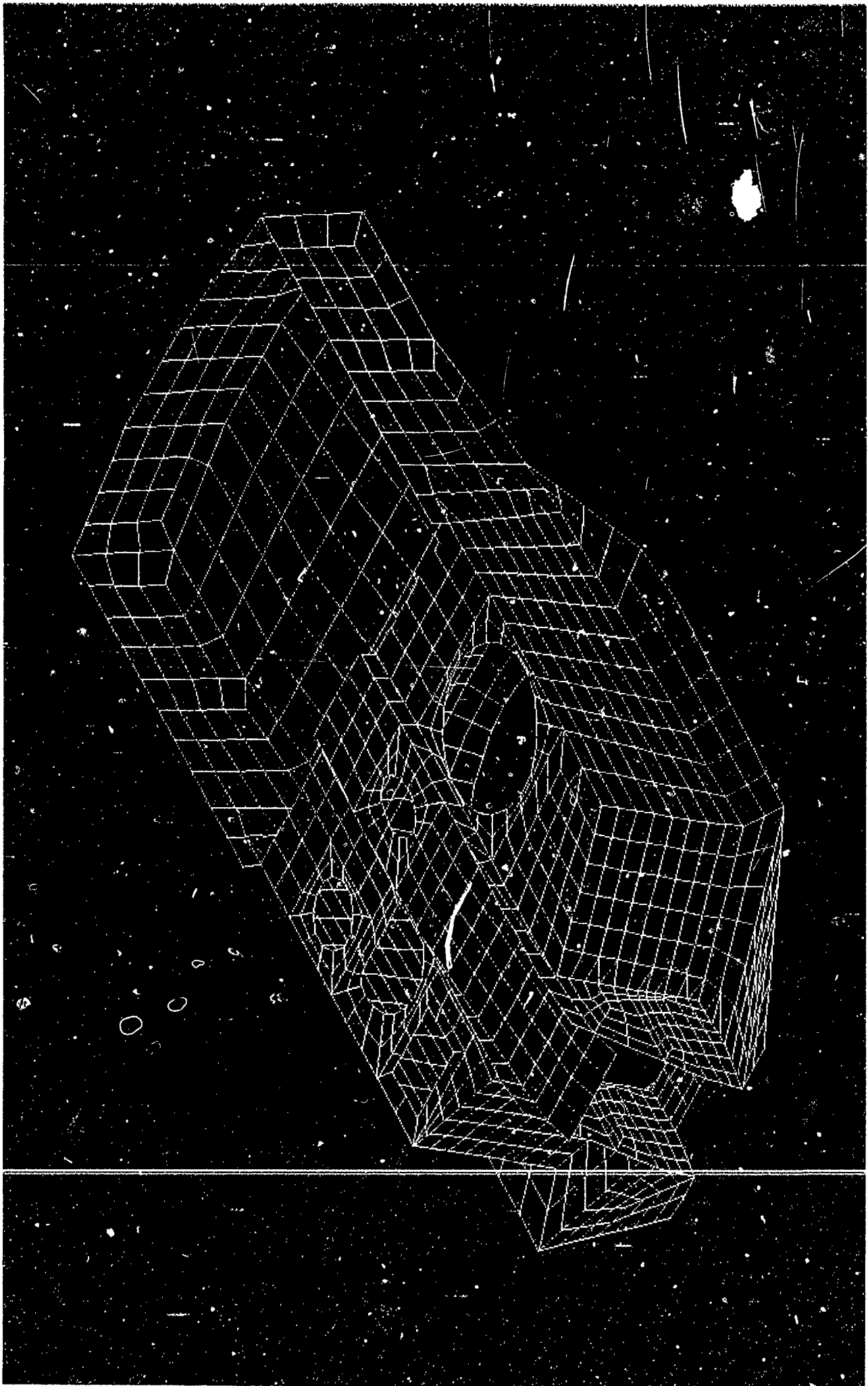
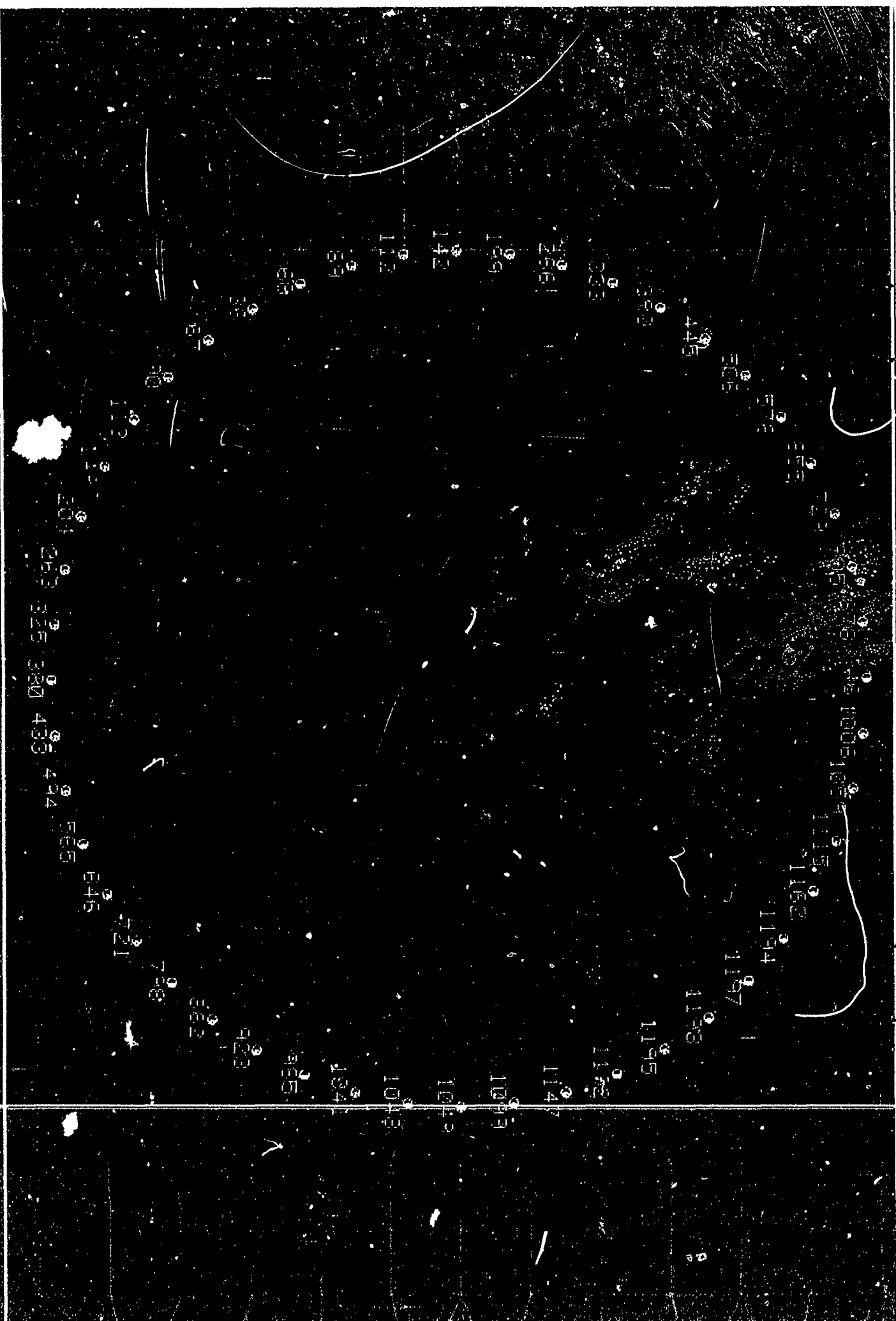

FIG 17 - CATTB TURRET FEM MODEL



J - 4.405E+04
 I - 3.965E+04
 H - 3.524E+04
 G - 3.084E+04

C - 1.322E+04
 B - 8.811E+03
 A - 4.405E+03

LC5: VMBOT

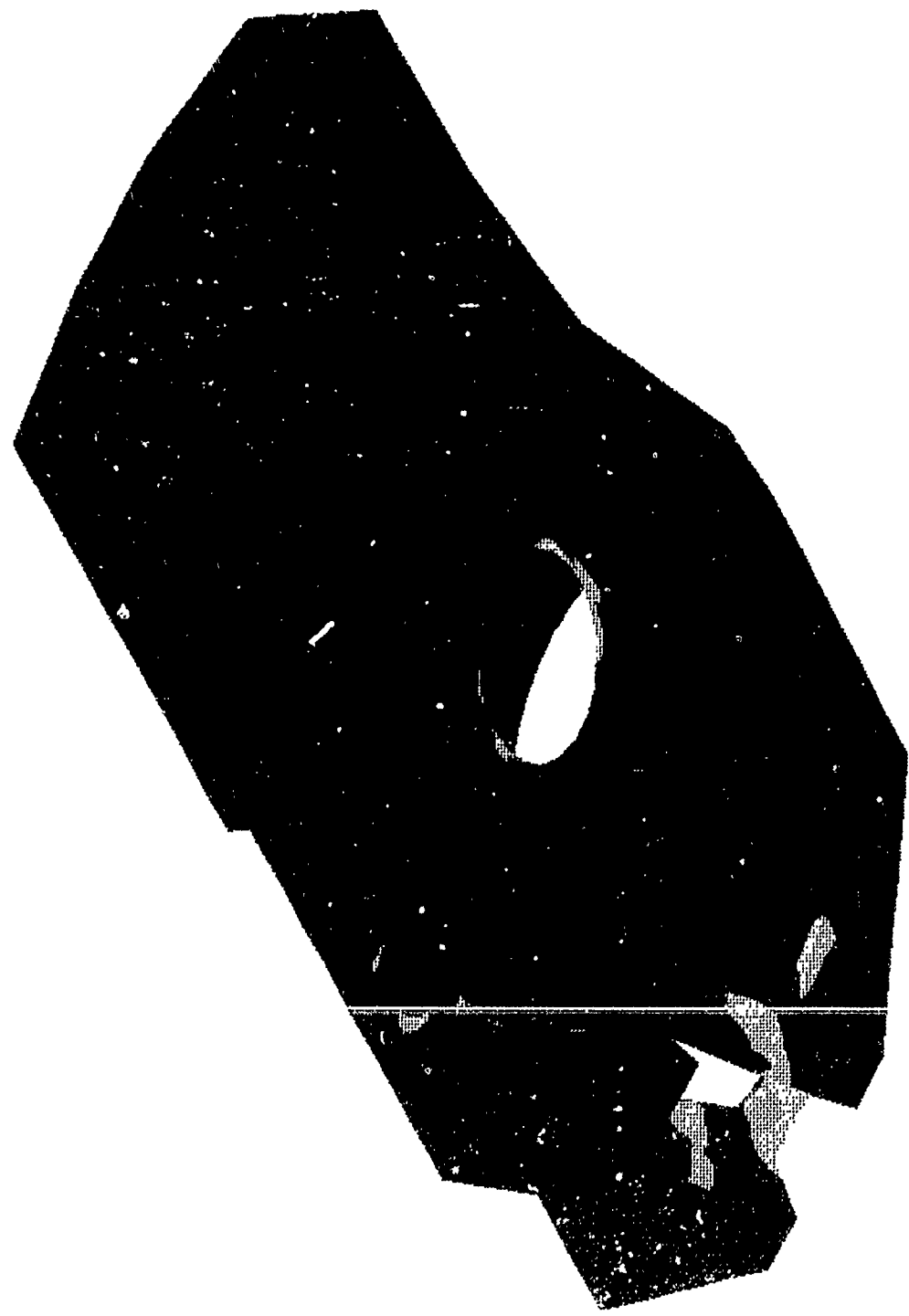

FIG 19 - IRM STRESS RESULTS (TURRET INDEPENDANT)

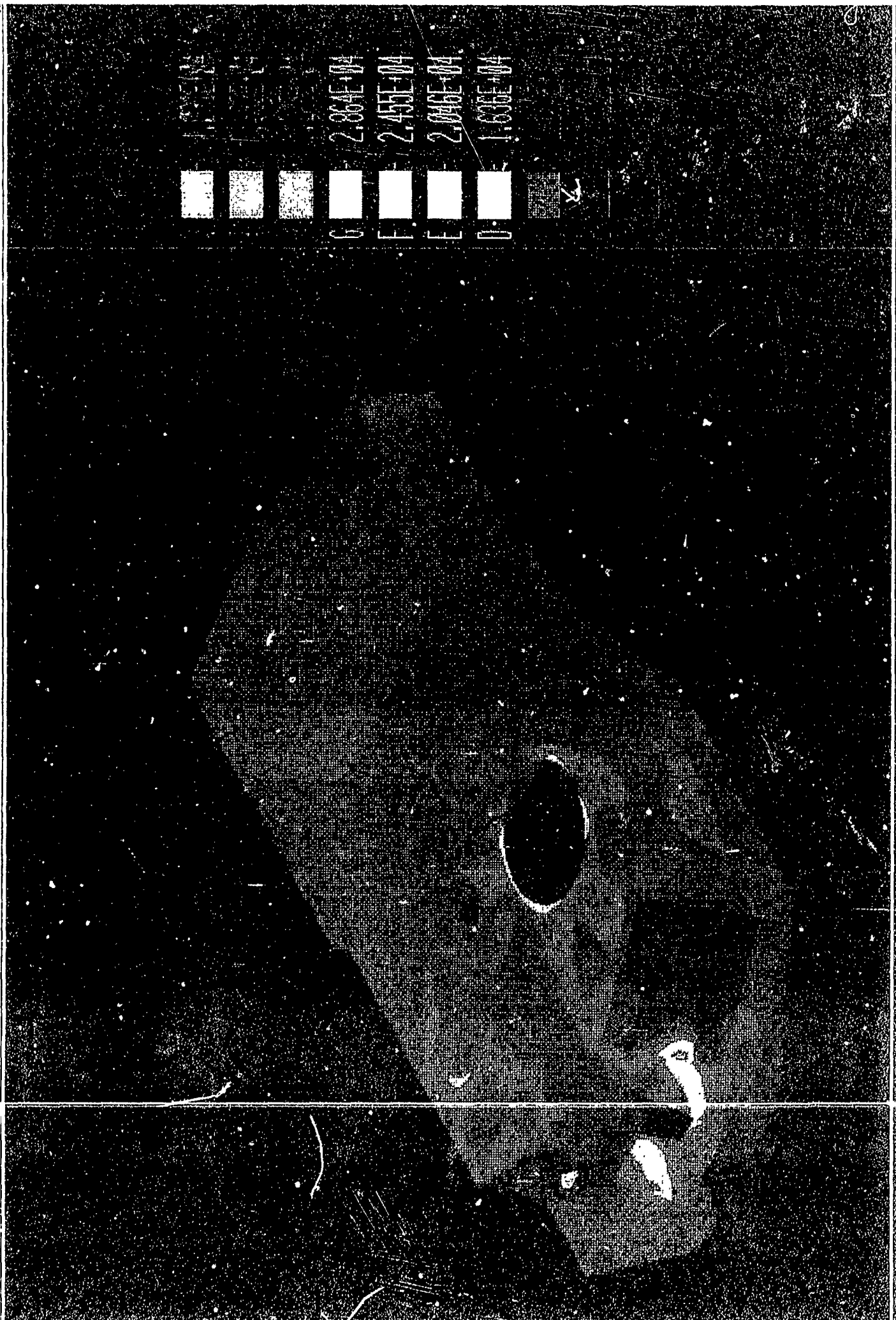
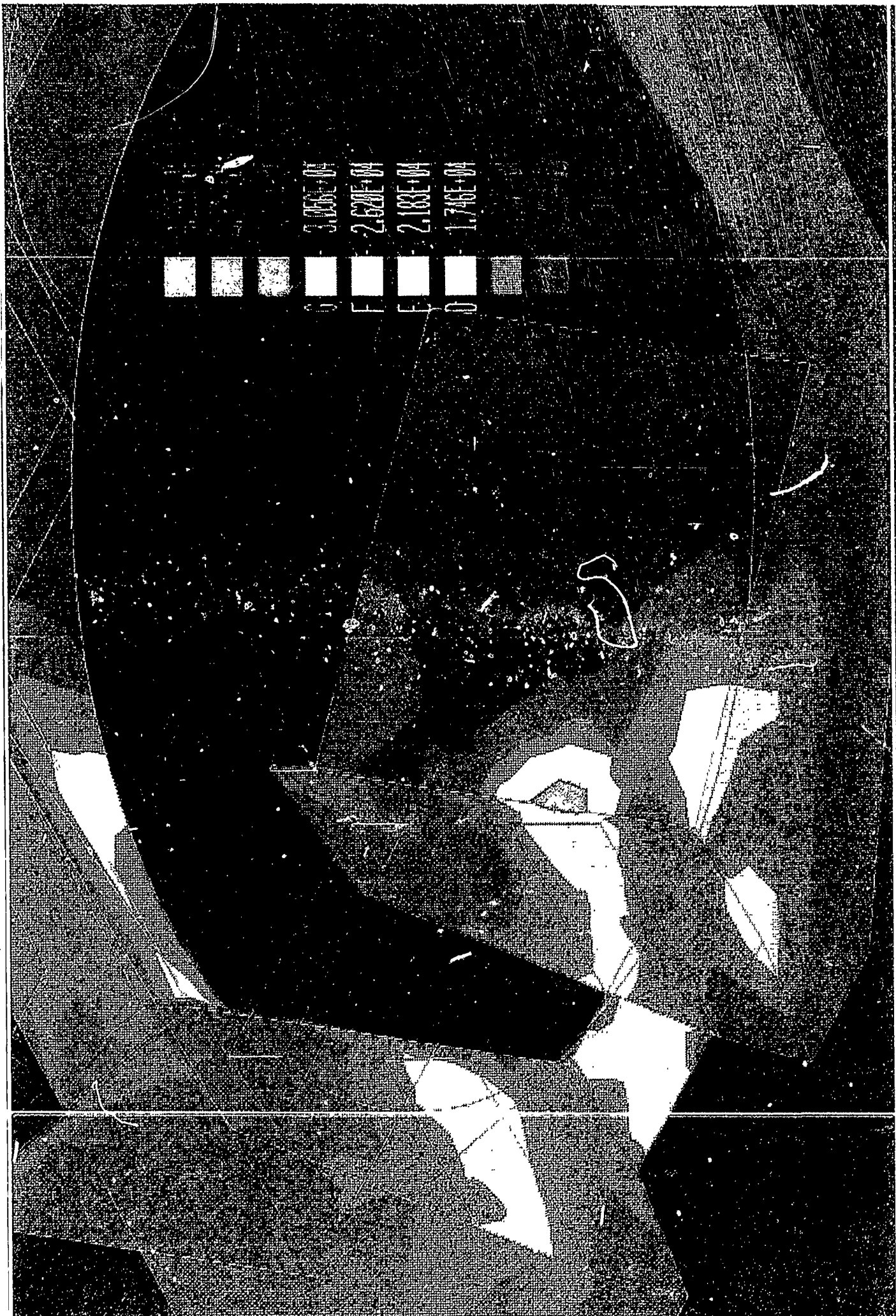
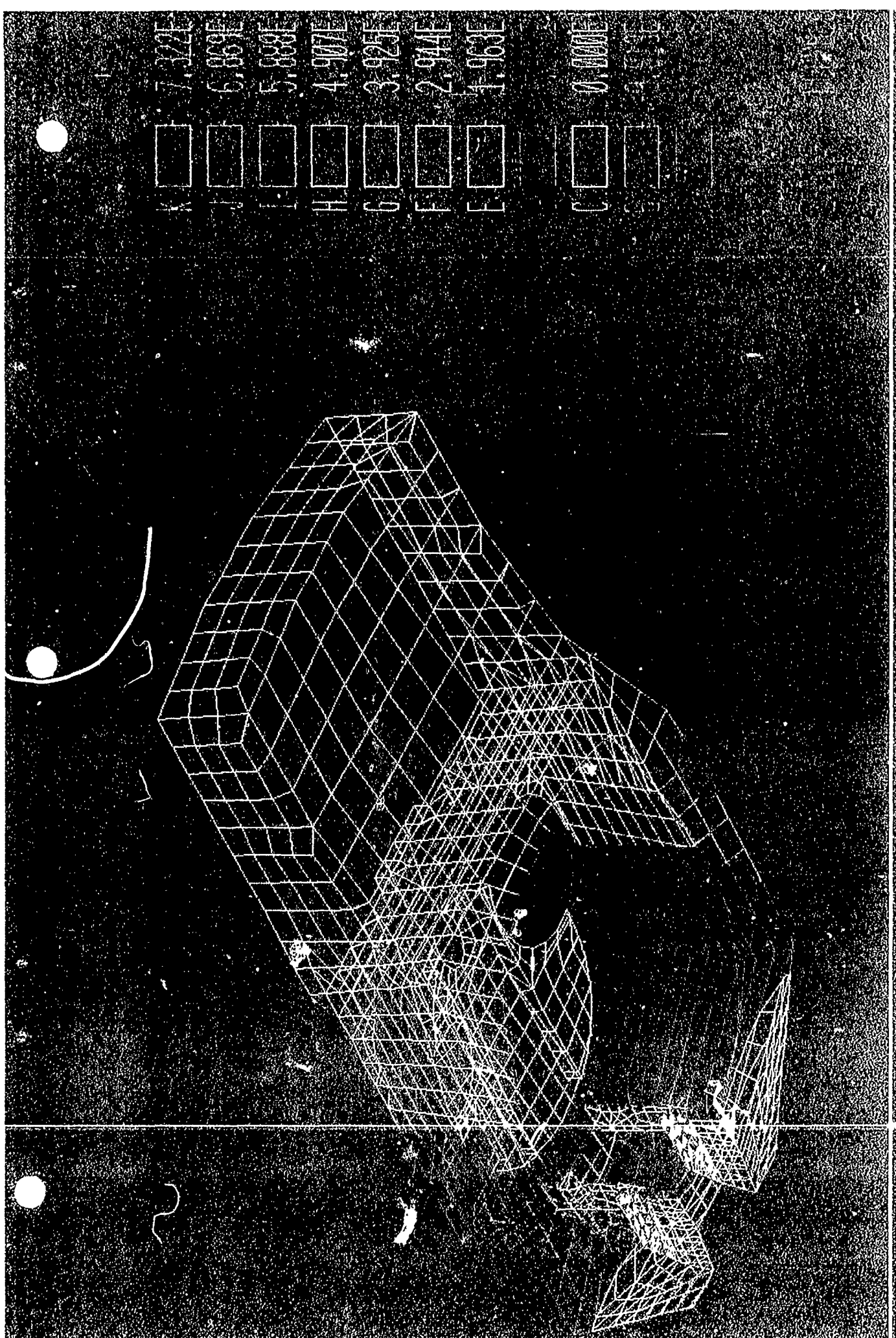

FIG 20 - IRM STRESS RESULTS (TURRET INDEPENDANT)



3.156E+04
2.620E+04
2.183E+04
1.746E+04

FIG 21 - IRM STRESS RESULTS (TURRET INDEPENDANT)



K	7.32E
J	6.869E
I	5.888E
H	4.907E
G	3.925E
F	2.944E
E	1.963E
C	0.000E
B	0.000E
A	0.000E

FIG 22 - IRM DEFLECTION RESULTS (TURRET INDEPENDANT)

E.M.R.C.- DISPLAY II POST-PROCESSOR VERSION 88.0 Apr/10/89

STRESS CONTOURS
VON-MISES STRESS
VIEW : 2.31E+01
RANGE : 7.61E+04
(Band # 1.0E2)

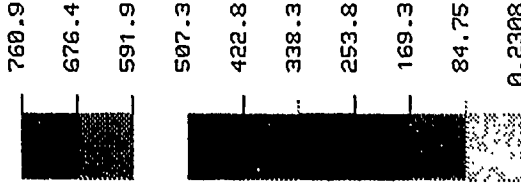
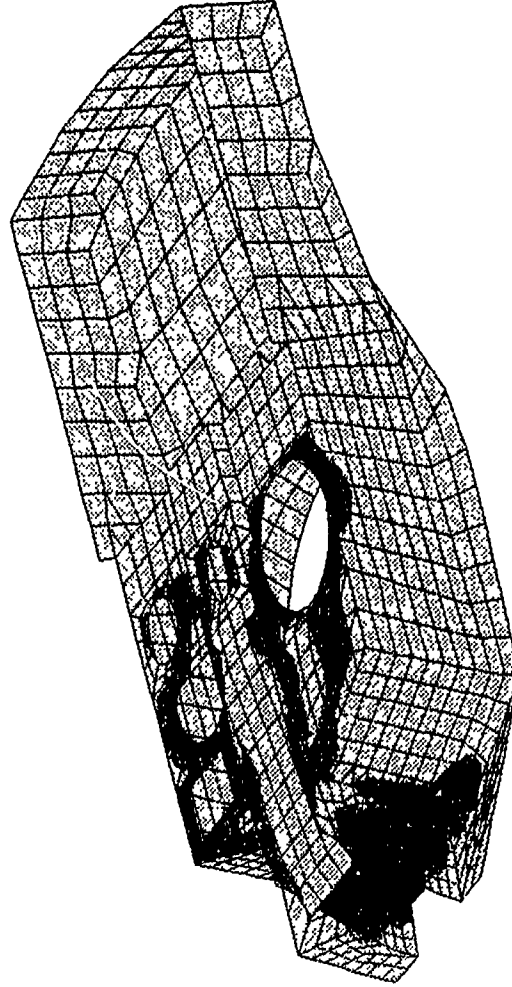

ATTN NISA MODEL
FIRING LOAD

RX= -60
RY= 0
RZ= 30

A small 3D coordinate system diagram with three axes labeled X, Y, and Z. The X-axis points to the right, the Y-axis points upwards, and the Z-axis points out of the page.

FIG 23
NISA STRESS RESULTS (TURRET INDEPENDANT)

E.M.R.C. - DISPLAY II POST-PROCESSOR VERSION 88.0 Apr/10/89

DISPL. CONTOURS
Z - DISPLACEMENTS
VIEW : -6.62E-02
RANGE : 1.63E-01

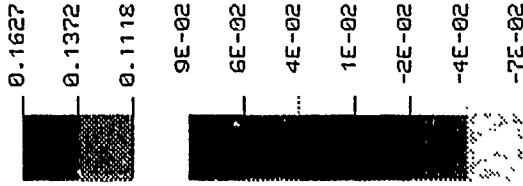
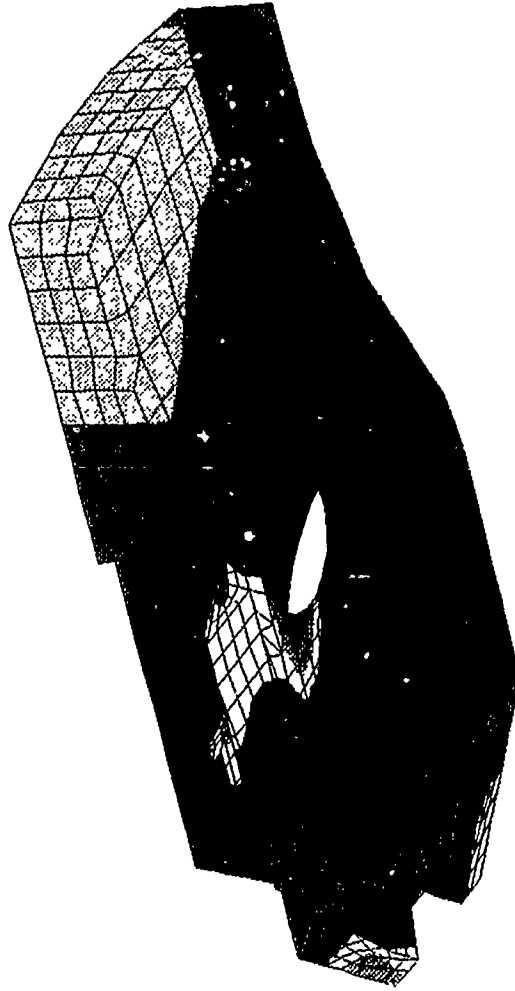

RX= -50
RY= 0
RZ= 30

A small diagram of a 3D coordinate system. The X-axis is horizontal, the Y-axis is vertical, and the Z-axis is diagonal. The axes are labeled with 'X', 'Y', and 'Z' respectively.

ATTD NISA MODEL
FIRING LOAD

SIGN DIVISION
STRUCTURES BRANCH
TTTB CASE 26-FIRING AT Ø H-10 V

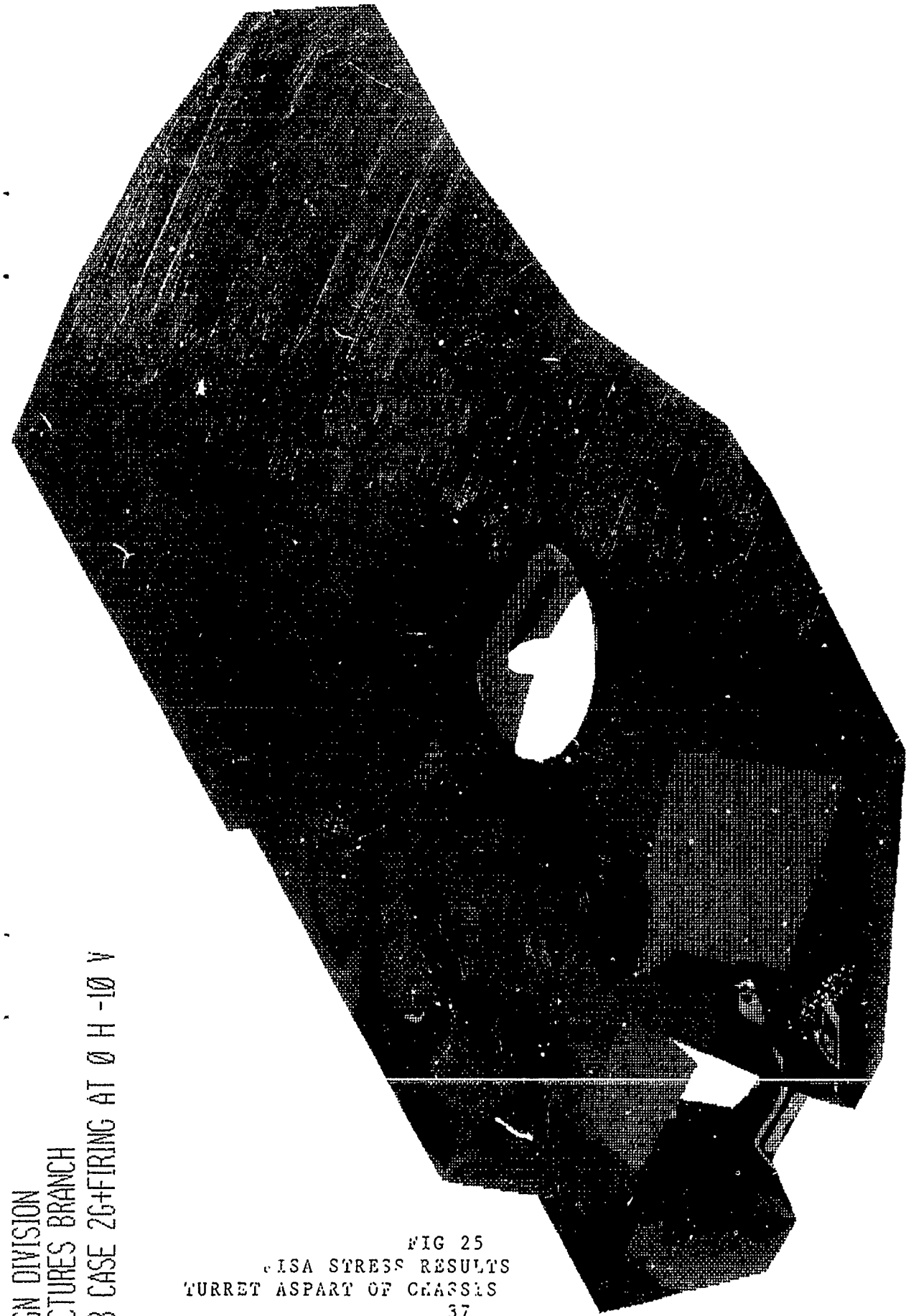
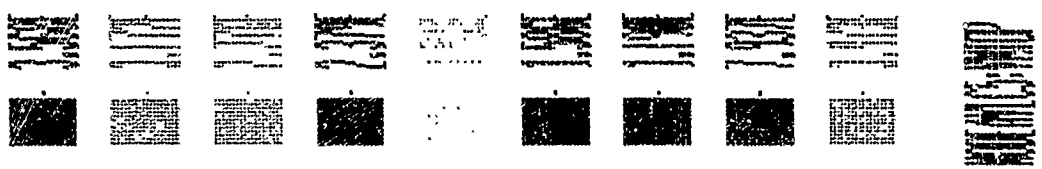
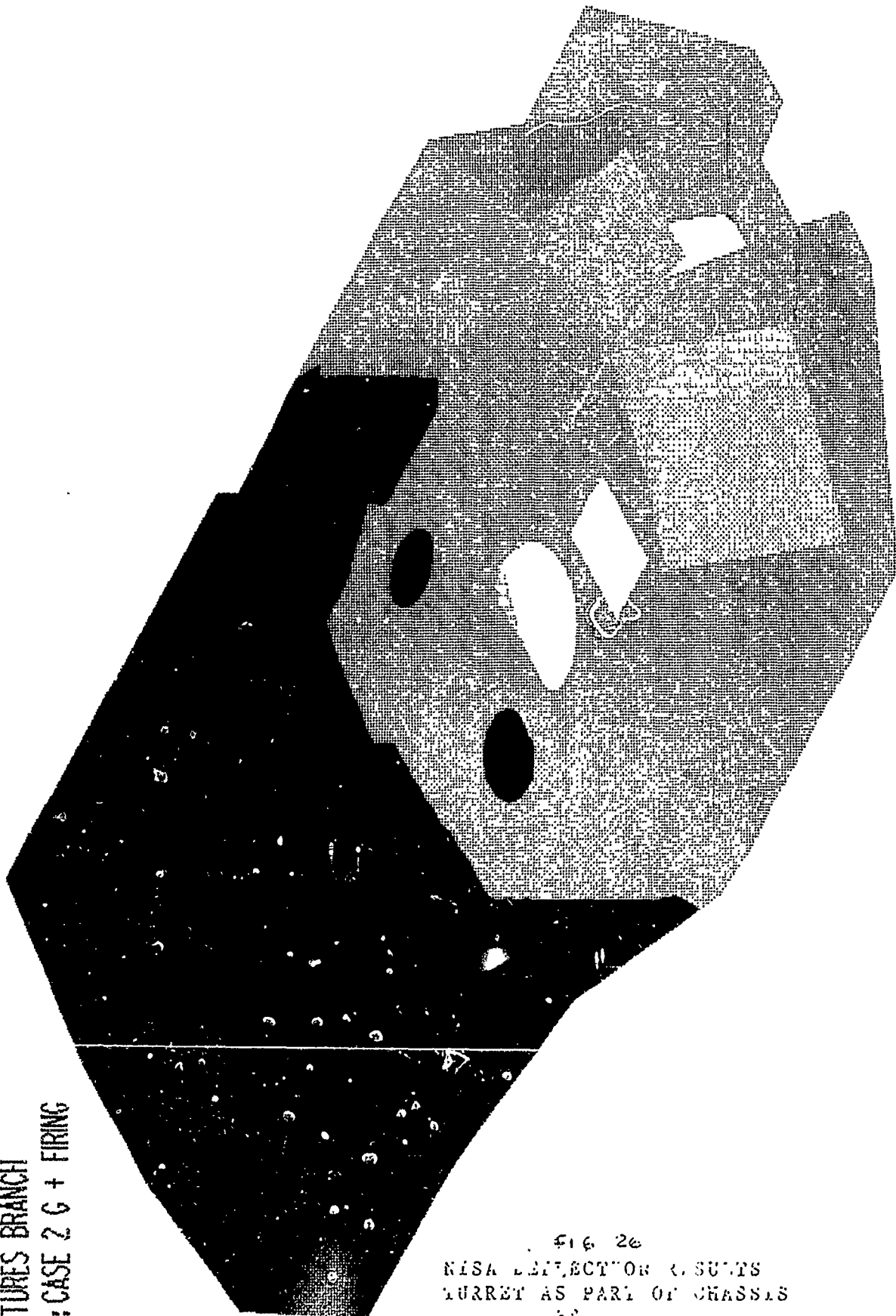
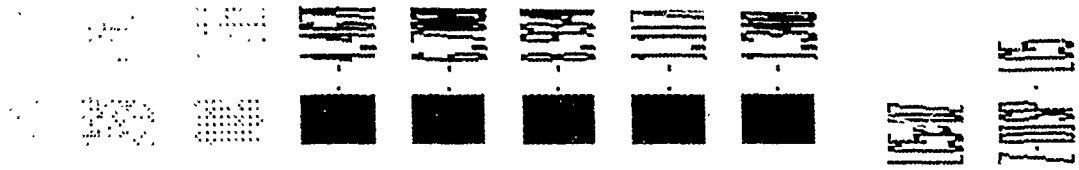

FIG 25
MISES STRESS RESULTS
TURRET ASPART OF CHASSIS

VON MISES
STRESS



VERT DEFORMATION
(IN)



ENGINEERING DESIGN DIVISION
FRACTURES BRANCH
TB; CASE 2 G + FIRING

FIG 26
NISA DEFLECTION RESULTS
TURRET AS PART OF CHASSIS
30

E.M.R.C.- DISPLAY II POST-PROCESSOR VERSION 89.0 Jan/ 4/90

STRESS CONTOURS
 VON-MISES STRESS
 VIEW : 3.56E+02
 RANGE : 6.69E+04

(Scale * 1.0E2)

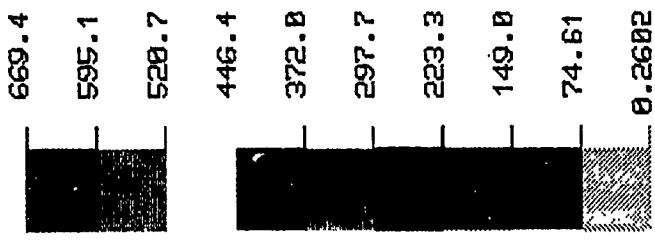
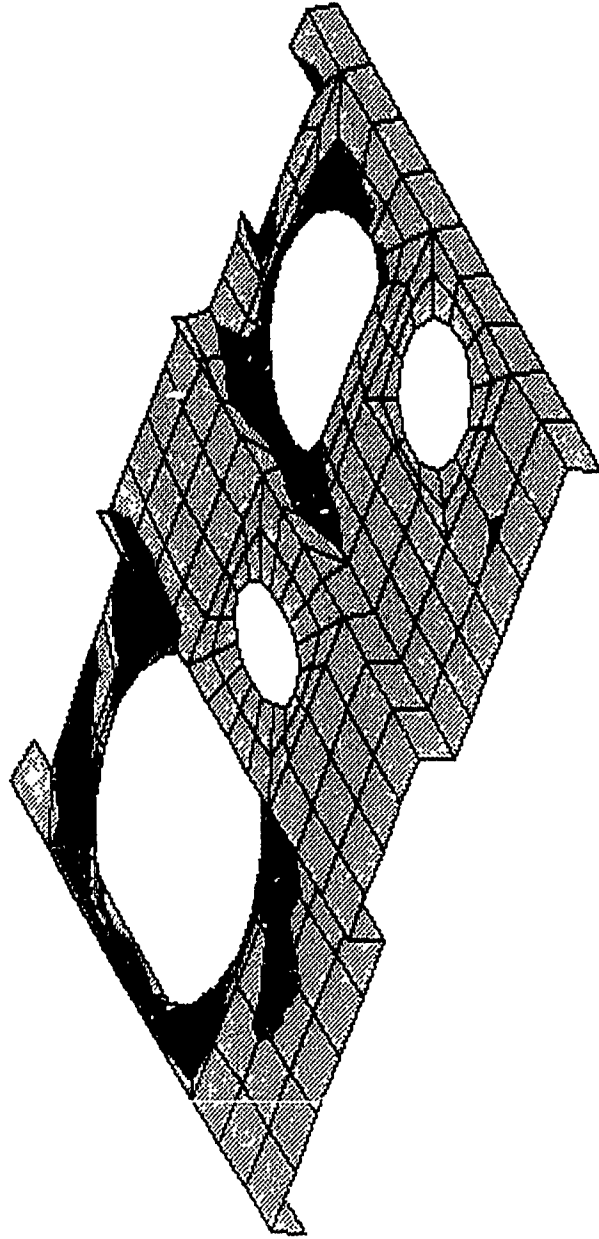

EMRC-NISA-DISPLAY



RX=-60
 RY= 0
 RZ=-130

CATTB NUETRAL FILE FROM PATRAN 7 NOV 89

FIG 27
 NISA STRESS RESULTS-TOP PLATE
 39

4.2.5 Trunnion Model

Preliminary turret stress analysis indicates high stress in the trunnion area (44,000 PSI). Since the trunnion strength will be reduced by the 8 holes (necessary to accommodate the mounting bolts), a detailed stress analysis for the trunnion is needed. For this, a solid finite element model for the trunnion was built (Fig. 28 & 29). This model consists of 1860 eight-noded solid brick elements and each node has three degrees of freedom (translation in x, y and z directions). The trunnion was constrained at the location of the turret casting and top plate.

4.2.6 Trunnion Load

The gun firing force is (375,000 lb). If this force increased by dynamic load factor of 2 (To account for the transient nature of load application), then each trunnion must transmit 375,000 lbs to the turret casting and top plate. This force is applied at the depth of the slot provided for mounting the gun block. The gun mounting block had to be secured by 8 mounting bolts to the trunnion to prevent any movement due to rebound effects. To accomplish this, it is necessary to torque the load mounting bolt so that the total pretension in them can resist the rebound recoil force. This pretension force is a compressive force applied at the perimeter of each mounting-bolt hole. A pretension load of 3200 lbs per bolt was used. This will give a 50,000-lb resistance or about 14% of the recoil force.

4.2.7 Trunnion Analysis Results

The maximum VON mises stress is 57,000 PSI, and it occurs just below the surface of the inner face of the trunnion at the edge of the slot for mounting the gun block (Fig 30). A detailed stress plot for this area is shown in (Fig 31). The maximum stress due to pretension load of 3200 lb/bolt is in the range of 4000-5000 PSI, as shown in (Fig 32). Maximum horizontal deformation is 0.022 inches, as shown in (Fig 33). To keep stresses and deformations at their current level. The distance between slot and trunnion edges had to be increased from 3.0 to 3.75 inches, and trunnion thickness was increased from 4.5 to 5.5 inches as a result of this analysis.

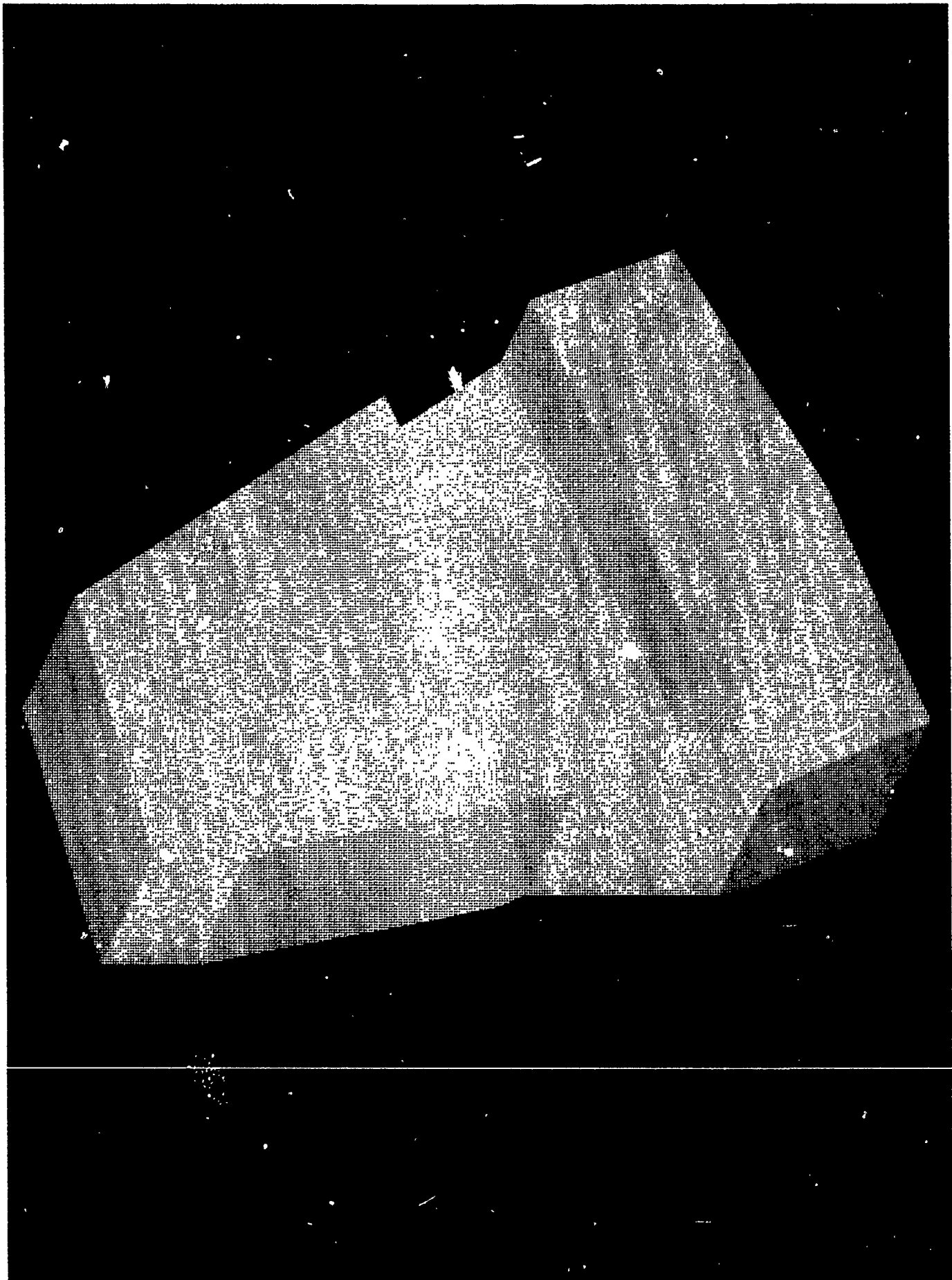

FIG 28
TRUNNION SOLID MODEL.
41

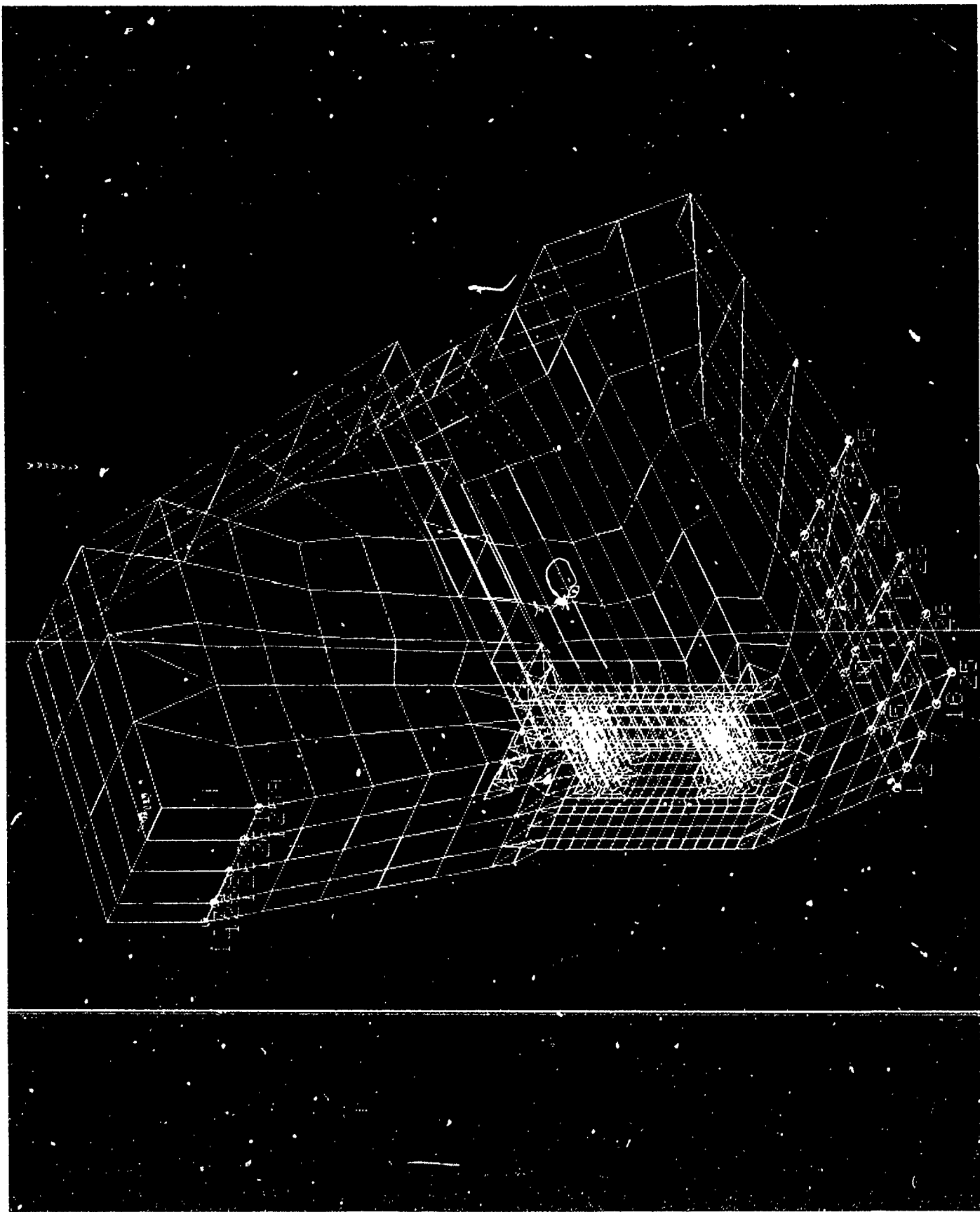

FIG 29
TRUNNION FEM MODEL
42

DESIGN DIVISION
STRUCTURES BRANCH
-ATTD - TURNION

VON MISES STR
(P.S.I.)

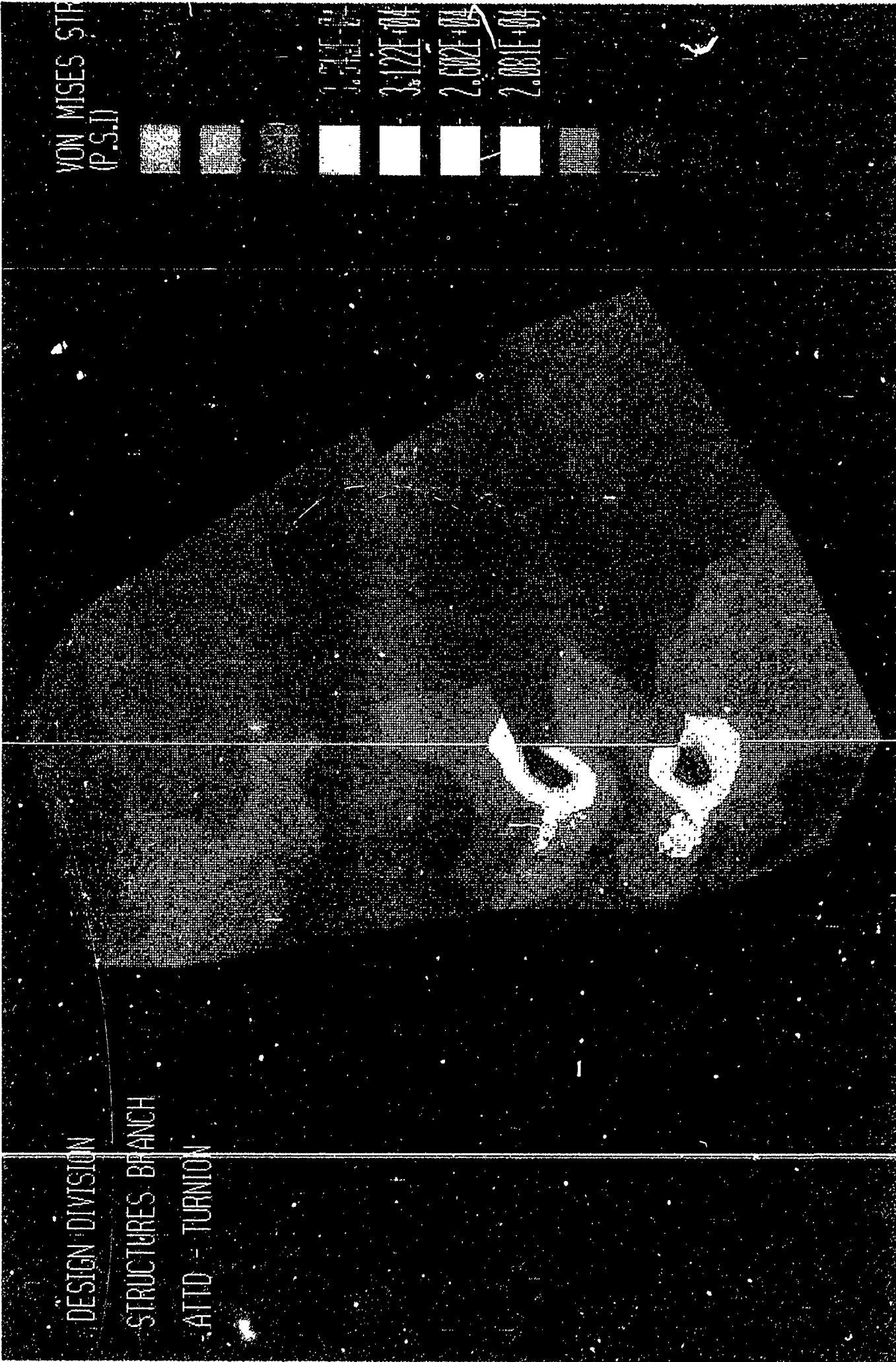
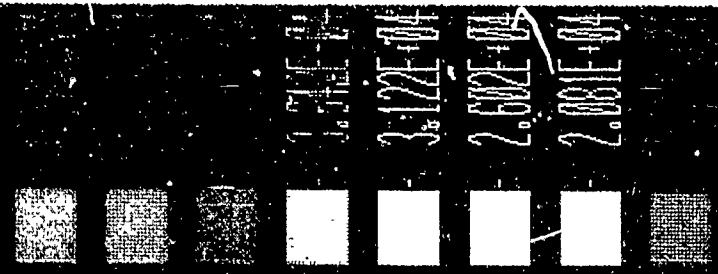

FIG 30 - TRUNNION STRESS RESULTS (FIRING LOAD)

FIG 31 - TRUNNION STRESS RESULTS (LOAD)

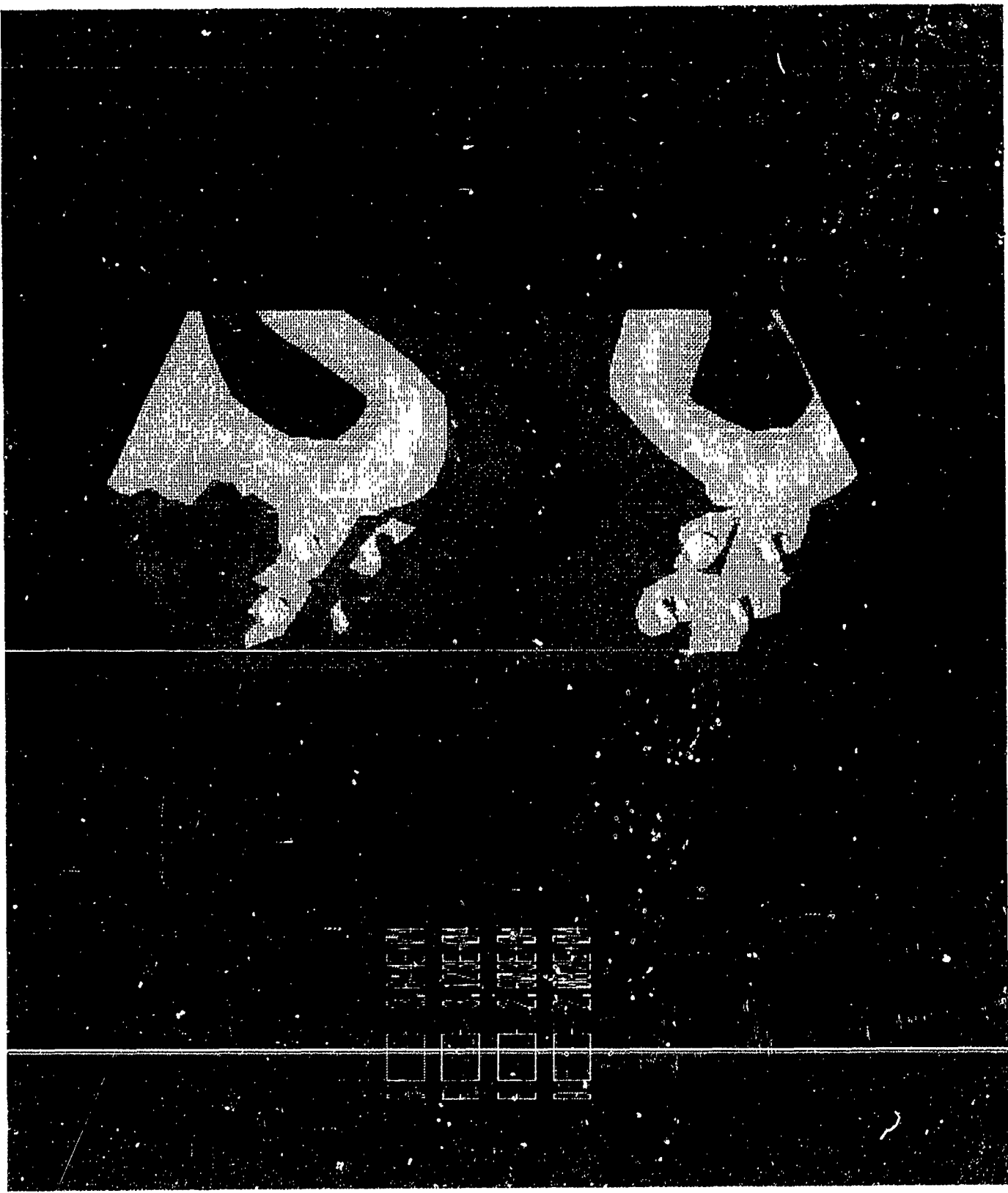
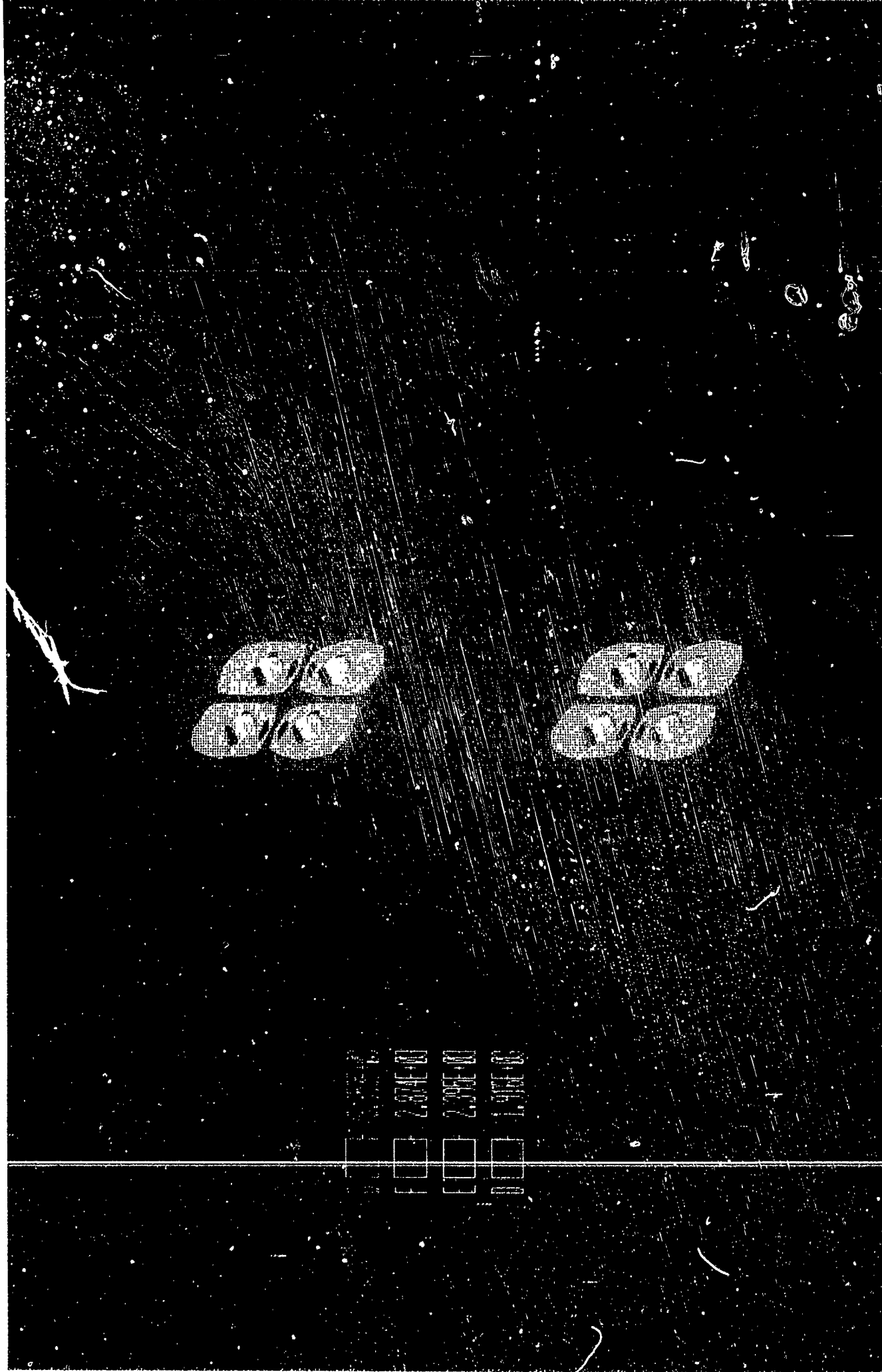

FIG 32 - TRUNNION STRESS RESULTS (PRETENSION LOAD)



2.84E-01
2.84E-01
2.84E-01
2.84E-01

FIG 33 - TRUNNION DEFLECTION RESULTS (FIRING LOAD)



4.2.8 Turret and Hull Castings

The turret and hull casting, are complicated parts and their interaction through the race ring deserves a separate study by itself. To represent turret and hull casting in this study in the best possible way some simplifications were necessary. The turret race ring was replaced in the FEM Model with a stiff truncated cone (2.5 inches thick). This allowed the forces to be transferred from the turret to the hull with minimum deformations. The hull casting configurations in the finite element model were obtained in such a way that the hull casting FEM model has the same mass properties obtained for the 3D solid model available on the Intergraph CAD System and obtained utilizing EMS.

4.2.9 Casting Analysis Results

Stresses and deformation for the turret and hull castings were extracted from the total chassis results for the following two cases:

4.2.9.1 Gun Firing At 0 degrees Horizontal

Maximum VON mises stress in the turret and hull casting is in the range of 30,000 PSI as shown in Fig (34 - 36). Stresses in these casting around the trunnion area are shown in Fig (37 & 38). Vertical deformation plots are shown in Fig (39).

4.2.9.2 Gun Firing at 90 degrees Horizontal

Max VON mises stress is 36,000 PSI as shown in Fig (40 & 41). Lateral displacement are shown in Fig (42). Stresses in trunnion and hull casting and around road where no 3 are shown in Fig (43).

E.M.R.C.- DISPLAY II POST-PROCESSOR VERSION 89.0 Jan/11/90

STRESS CONTOURS
VON-MISES STRESS
VIEW : 4.88E+02
RANGE : 3.34E+04
(Band * 1.0E2)

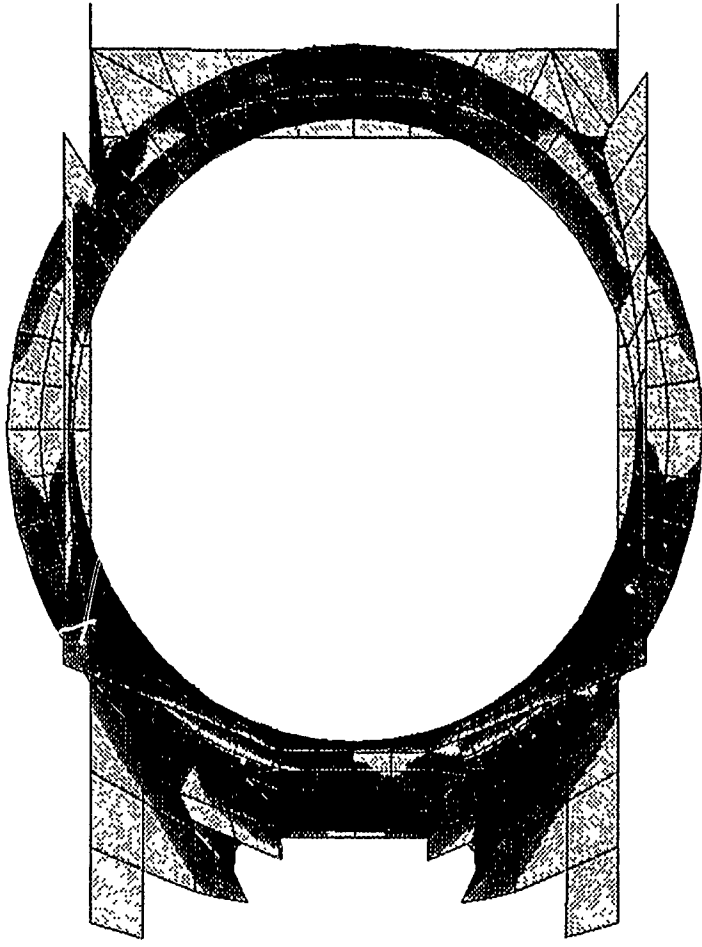

662.3
588.8
515.2
441.6
368.1
294.5
220.9
147.3
73.77
0.2005

EMRC-NISA/DISPLAY

Y
X
RX= 0
RY= 0
RZ= 0

CATTB NUETRAL FILE FROM PATRAN 7 NOV 89

FIG 34
STRESS IN TYRRET AND HULL CASTINGS-GUN FIRING AT 0

E.M.R.C.- DISPLAY II POST-PROCESSOR VERSION 89.0 Jan/11/90

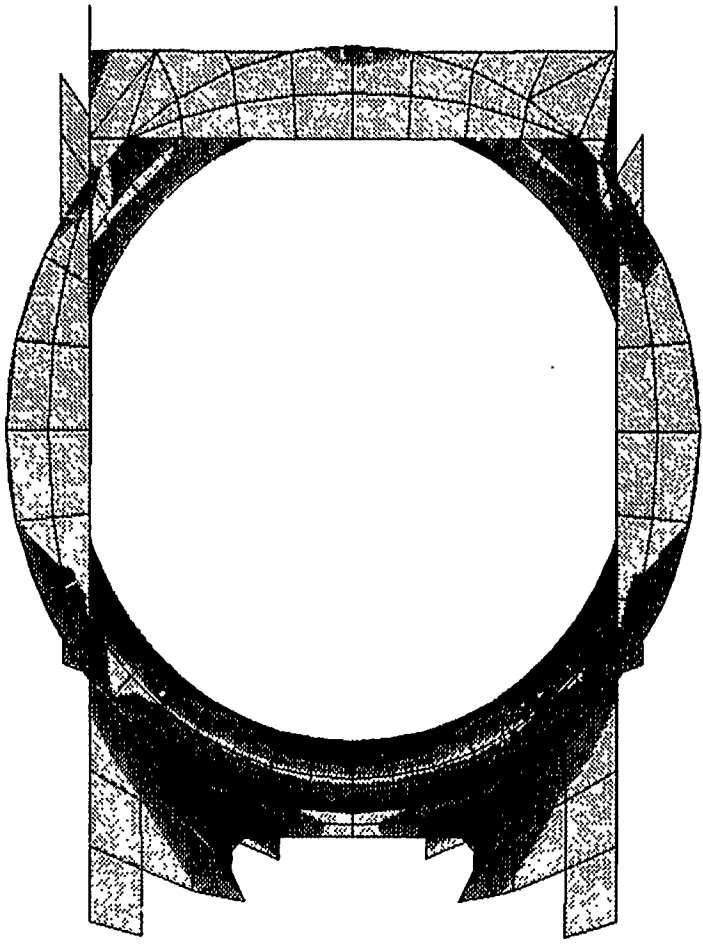

STRESS CONTOURS
 VON-MISES STRESS
 VIEW : 4.88E+02
 RANGE : 3.34E+04
 (Band * 1.0E2)

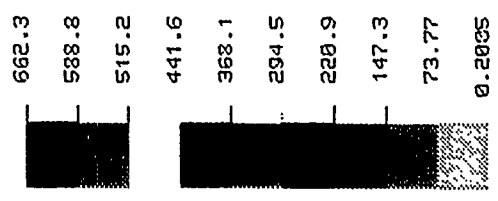

EMRC-NISA/DISPLAY

X RX=-130
 Y RY= 0
 Z RZ= 0

CATTB NUETRAL FILE FROM PATRAN 7 NOV 89

FIG. 35
 STRESS IN TURRET AND HULL CASTINGS-GUN FIRING AT 0°
 49

E.M.R.C. - DISPLAY II POST-PROCESSOR VERSION 89.0 Jan/11/90

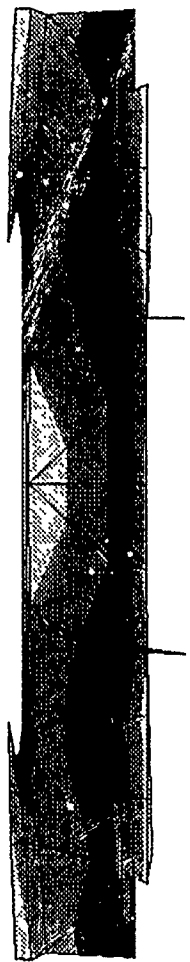

STRESS CONTOURS
 VON-MISES STRESS
 VIEW : 9.46E+02
 RANGE : 3.34E+04
 (Band * 1.0E2)

662.3
588.8
515.2
441.6
368.1
294.5
220.9
147.3
73.77
0.2005

EMRC-NISA/DISPLAY

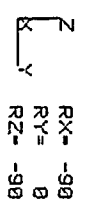

RX= -90
 RY= 0
 RZ= -90

CATT8 NUTRAL FILE FROM PATRAN 7 NOV 89

E.M.R.C. - DISPLAY II POST-PROCESSOR VERSION 89.0 Jan-11/90

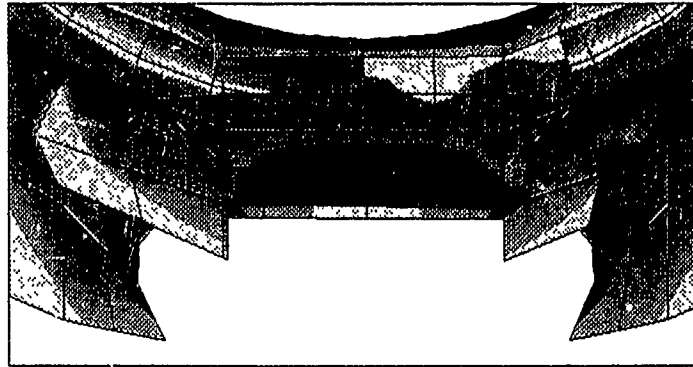

STRESS CONTOURS
VON-MISES STRESS
VIEW : 9.46E+02
RANGE : 3.34E+04
(Band x 1.0E2)

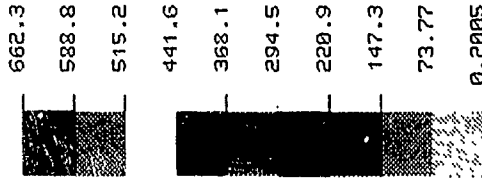

EMRC-NISA-DISPLAY

Y
Z
X
RX= 0
RY= 0
RZ= 0

CATT8 NUTRAL FILE FROM PATRAN 7 NOV 89

FIG 37
STRESS IN TURRET AND HULL CASTINGS-GUN FIRING AT 0°

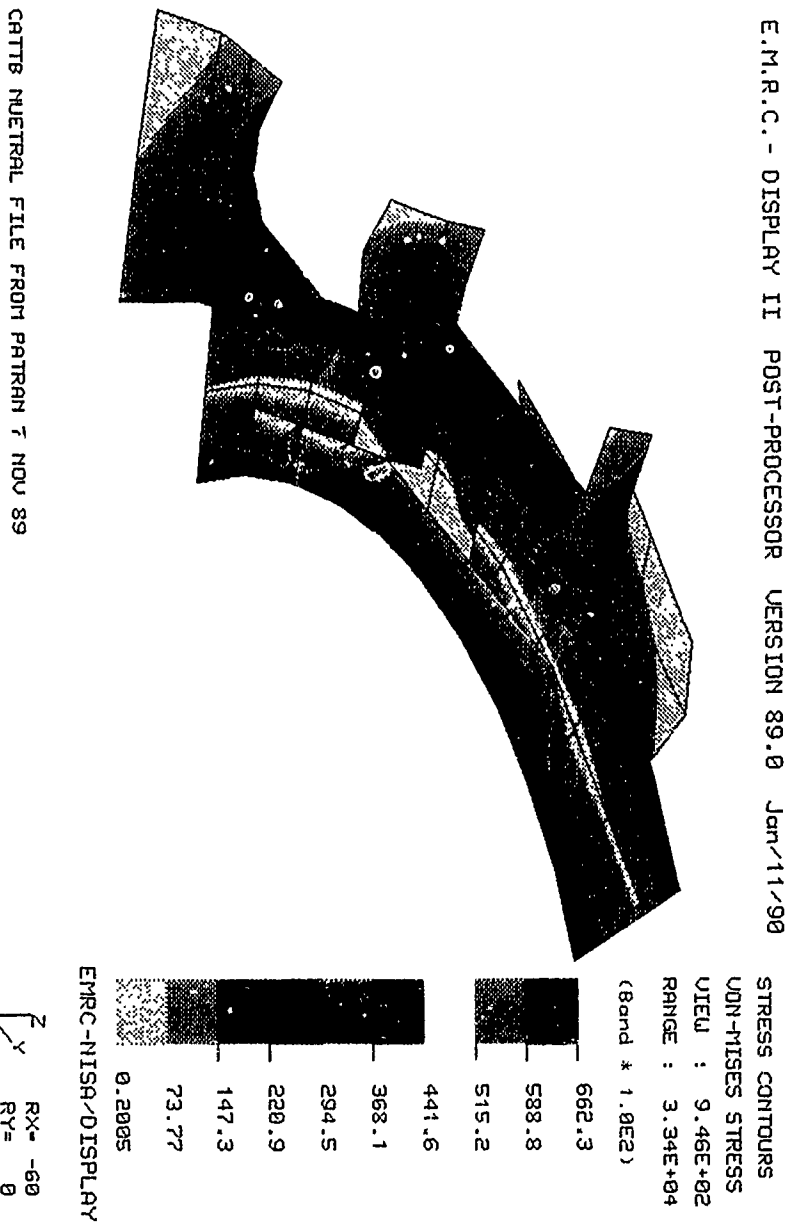

E.M.R.C. - DISPLAY II POST-PROCESSOR VERSION 89.0 Jan/11/90

DISPL. CONTOURS
Z - DISPLACEMENTS
VIEW : -1.09E-01
RANGE : 1.43E-01

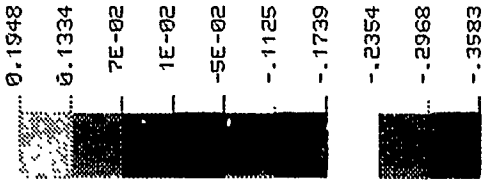
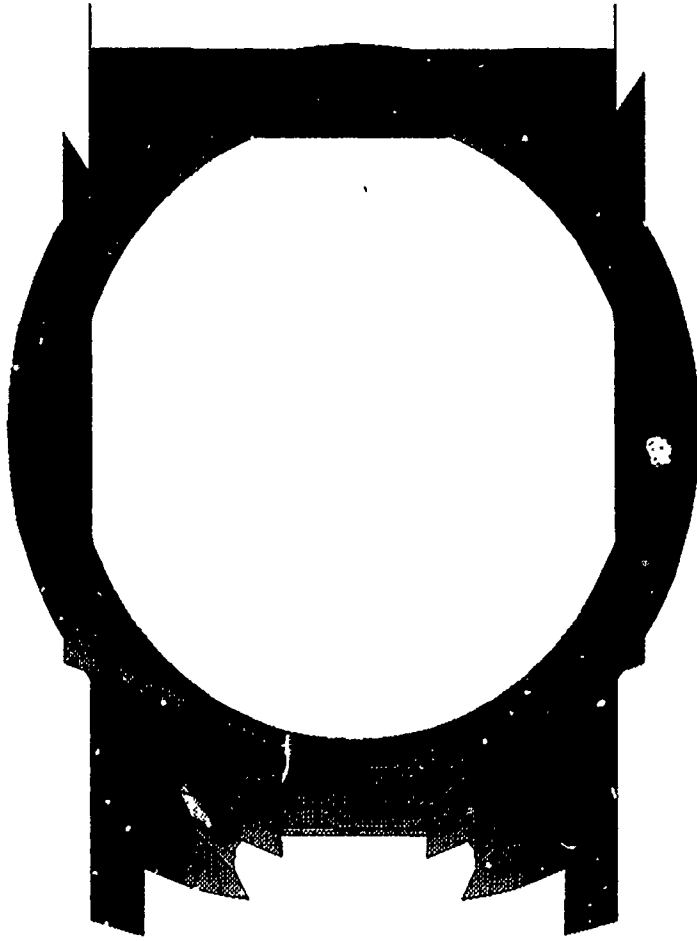

EMRC-NISA/DISPLAY

$\begin{matrix} Y \\ | \\ \hline X \end{matrix}$
 RX= 0
 RY= 0
 RZ= 0

CATTS NUETRAL FILE FROM PATRAN 7 NOV 89

FIG 39

53

CRITICAL DEFORMATIONS IN TURRET AND HULL CASTINGS-GUN FIRING AT 0

E.M.P.C. - DISPLAY II POST-PROCESSOR VERSION 89.0 Jan/11/90

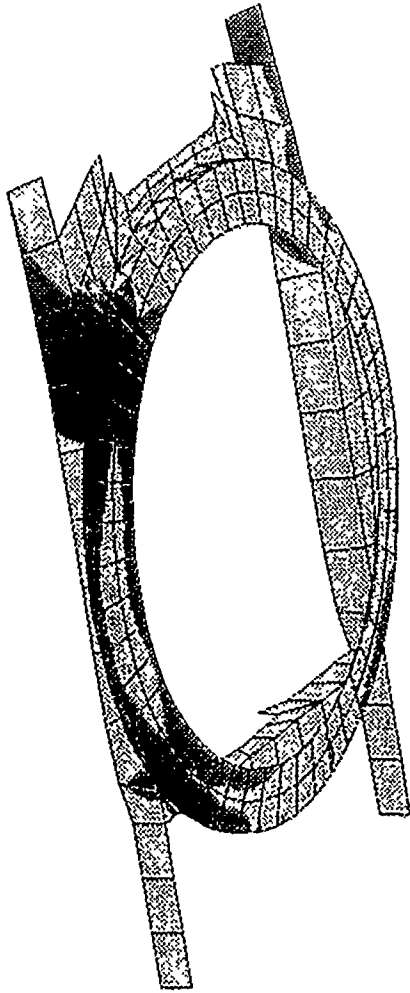

CATTB NEUTRAL FILE FROM PATRAM
 BOTTOM LAYER

STRESS CONTOURS
 VON-MISES STRESS
 VIEW : 2,17E+0E
 RANGE : 3,16E+04
 (Band A 1.0E2)

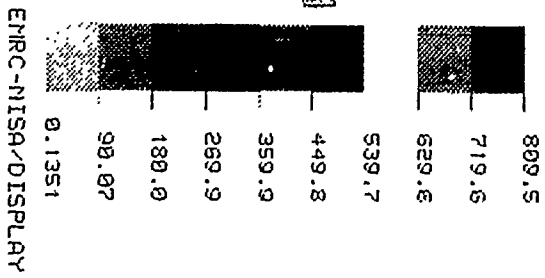

RX = -60
 RY = 0
 RZ = 20

E.M.R.C. - DISPLAY II POST-PROCESSOR VERSION 89.0 Jan/11/90

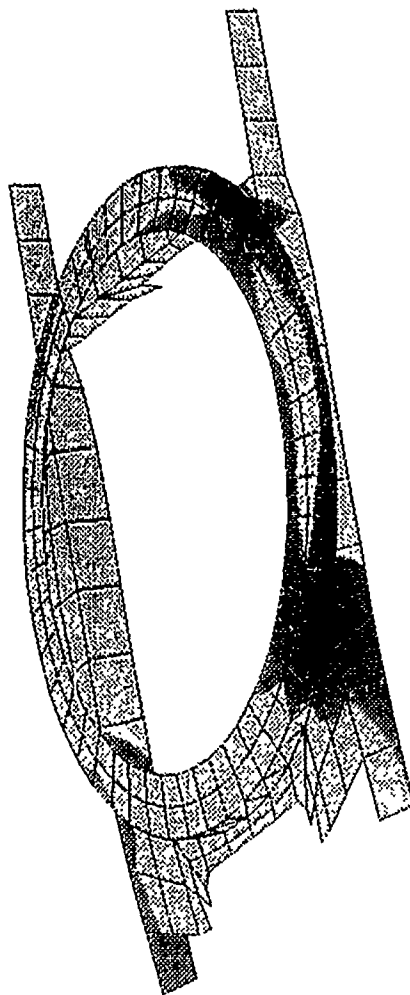

STRESS CONTOURS
OCTAHEDRAL STRESS
VIEW : 1.0E2+02
RANGE : 1.49E+04
(Band A 1.0E2)

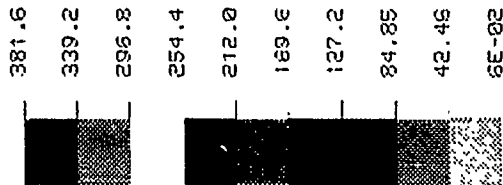

EMRC-NISA/DISPLAY

RX= -60
RY= 0
RZ= 20

CATTS NEUTRAL FILE FROM PATRAN
BOTTOM LAYER

DISPL. CONTOURS
 Y - DISPLACEMENTS
 VIEW : 1.40E-01
 RANGE : 2.47E-01

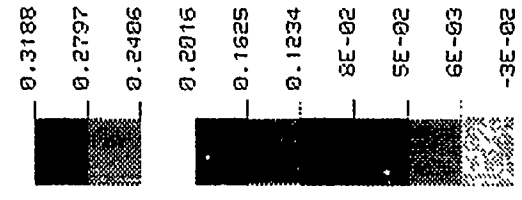

EMRC-NISA/DISPLAY

RX= -60
 RY= 0
 RZ= 20

E.M.R.C. - DISPLAY II POST-PROCESSOR VERSION 89.0 Jan/11/90

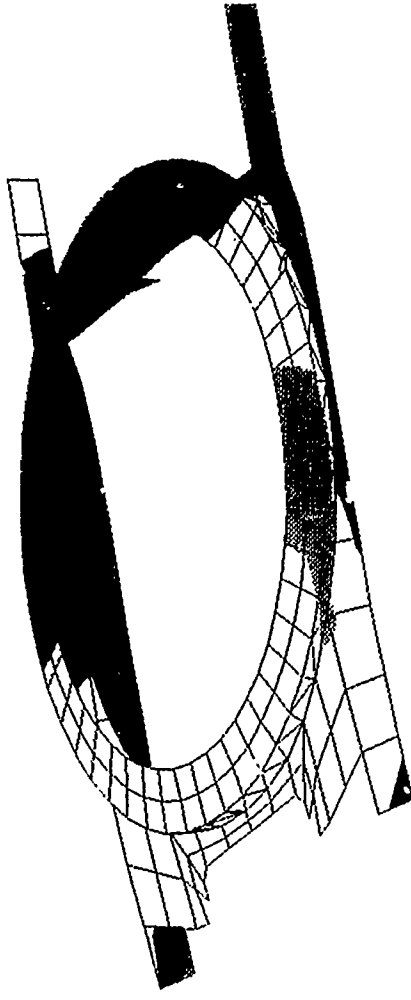

CATTS NEUTRAL FILE FROM PATRAN
 BOTTOM LAYER

E.M.R.C. - DISPLAY II POST-PROCESSOR VERSION 89.0 Jan/ 4/90

STRESS CONTOURS
 VON-MISES STRESS
 VIEW : 4.97E+02
 RANGE : 3.62E+04

(Band * 1.0E2)

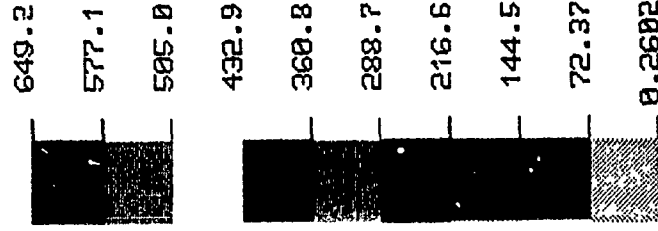
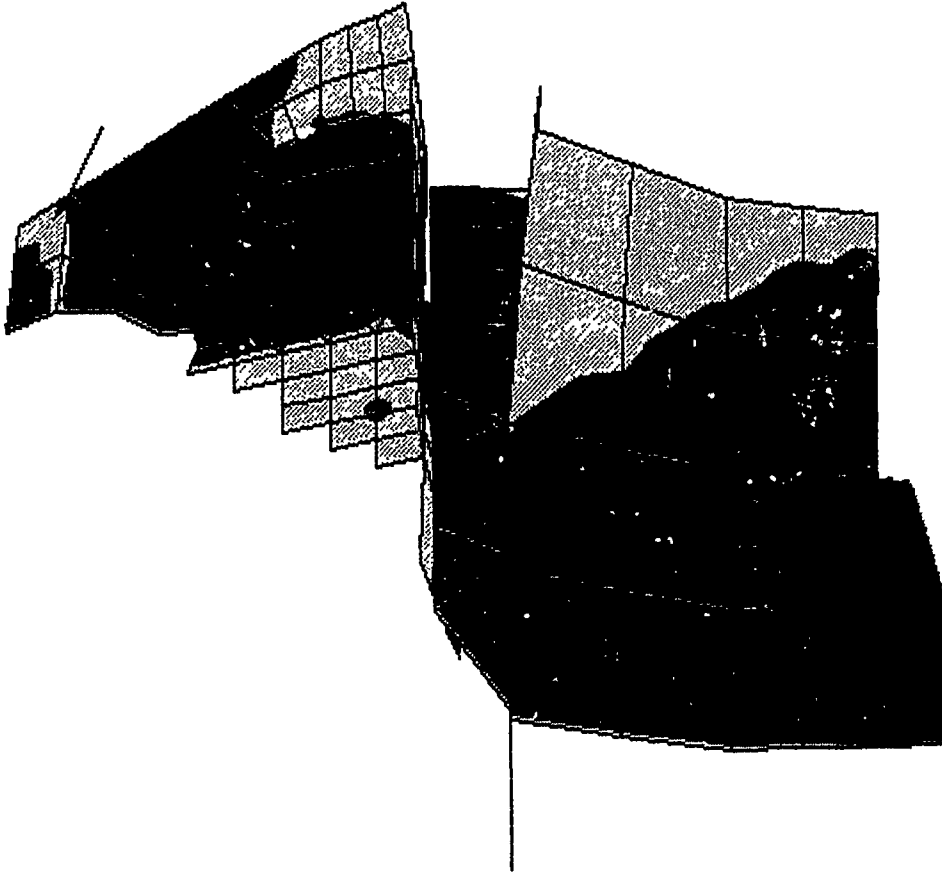

EMRC-NISA-DISPLAY

Z
 Y
 X
 RX= -90
 RY= 0
 RZ= 180

CATTB NUTRAL FILE FROM PATRAN 7 NOV 89

FIG 43
 STRESS IN TURRET AND HULL CASTINGS-
 57

GUN FIRING AT 90°

4.2.10 Hull Model

The M1A1 hull will be used and modified where necessary to assure strength and space utilization. The hull finite element model was created using IRM software in similar fashion to turret FEM model. A wire frame was created from a 3D solid model available on the Intergraph CAD System. Then this wire frame was translated to IGDS and transferred to the VAX computer to serve as a skeleton for the finite element model Fig (44). Thickness of the various plates are shown in Fig (45). The hull was constrained in the vertical direction at all roadwheel attachment points. In the horizontal direction, the hull was constrained at the attachment points of the roadwheels 1 and 7, to maximize the bending effects in the chassis due to lateral loads.

4.2.11 Hull Loads

The reaction forces in the 48 mounting bolts found in the FEM turret analysis (Appendix C) was applied on the hull model and analyzed. The results indicated high stress (130,000 PSI) in the hull top plate around the trunnion area. In this preliminary analysis, the interaction between the turret and hull was not considered, resulting in high stress. To represent the real situation, this interaction must be considered. For this, it was necessary to merge turret FEM model with hull FEM model resulting, in chassis FEM model Fig (46 & 47). This model will be analyzed as one entity.

4.2.12 Hull Analysis Results

Gun-firing load was applied to the chassis FEM model, and the results are as follow:

4.2.13.1 Gun Firing at 0 degrees Horizontal

Stresses in the hull are in the range of 60,000 PSI, as shown in Fig (48).

4.2.12.2 Gun Firing at 90 degrees Horizontal

To investigate this case, another CATTB FEM model had to be created by rotating the turret 90 degrees as shown in Fig (49). This model was analyzed, and the hull stresses are in the range of (95,000 - 130,000) PSI Fig (50 & 51). Depending on the number of roadwheel attachment points constrained in the lateral direction (7 and 2 respectively), the hull lateral deformation for these two ranges from 0.16 - 0.25 inches, as shown in Fig (52). The hull's deformed shape are shown is Fig (53).

It is worthwhile to note that shear stress in the hull (36,000 PSI) is closer to its yield limit (50,000 PSI) than bending stress (65,000 PSI) to its yield limit (100,000 PSI). This is due to the dominant shear behavior in the trunnion, turret, and hull casting near the trunnion area. Chassis deformed shapes are shown in Fig (68 & 69).

4.2.13 Hull Modification (1)

Hull stresses and deformations were excessive, and the hull had to be strengthened. This was accomplished by eliminating the blow-off panel in floor plate and by reducing the size of the opening in the middle bulkhead as shown in Fig (54).

4.2.14 Hull Analysis Results

After these modifications, the chassis was analyzed again. The stresses were reduced to (70,000 - 90,000) PSI Fig (55 & 56), and the lateral deflection were reduced to 0.15 - 0.2 inches Fig (57 & 58) for the two cases of roadwheel attachment points constraints mentioned previously.

4.2.15 Hull Modification (2)

Stresses and deformations are still reasonably high. The hull had to be strengthened in the lateral direction. This was accomplished by extending the hull casting plate between the two side-plates as shown in Fig (54).

4.2.16 Hull Analysis Results

Stresses were reduced to the 45,000 PSI range and deformation to 0.10 inches Fig (59 & 60). These values are over-estimated due to the simplicity of constraints assumption. In reality, all seven roadwheels resisted lateral displacement to a varied degree. To understand this behavior, a dynamic analysis is required when the turret is rotated 90 degrees.

4.2.17 Hull Modifications (3)

It was found necessary to reduce the height of the rear bulkhead, in order to be able to install the Auto Loader. The rear bulkhead contribute to hull's lateral strength. To study the effects of the bulkhead height on the chassis strength and stiffness, the bulkhead height was varied (from 33 to 20 & 13 inches).

4.2.18 Hull Analysis Results

Stresses in the hull were observed and are shown in Fig (61 - 63, & 67). Deformations are shown in Fig (64 - 67). The results indicated that the rear bulkhead height could be reduced to half of its original height before any significant reduction in hull strength and stiffness could be observed.

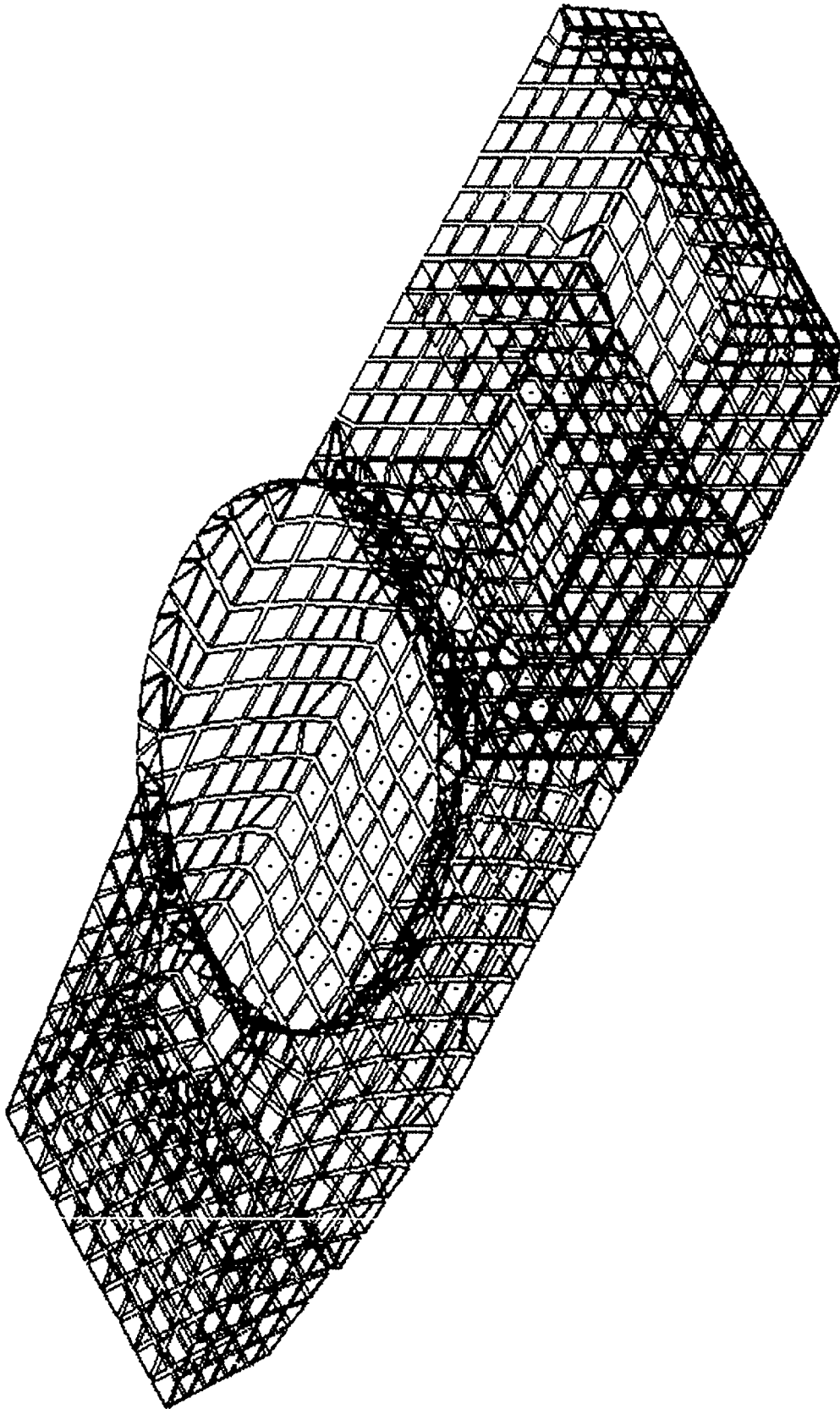

FIG 46
NULL FEM MODE
60

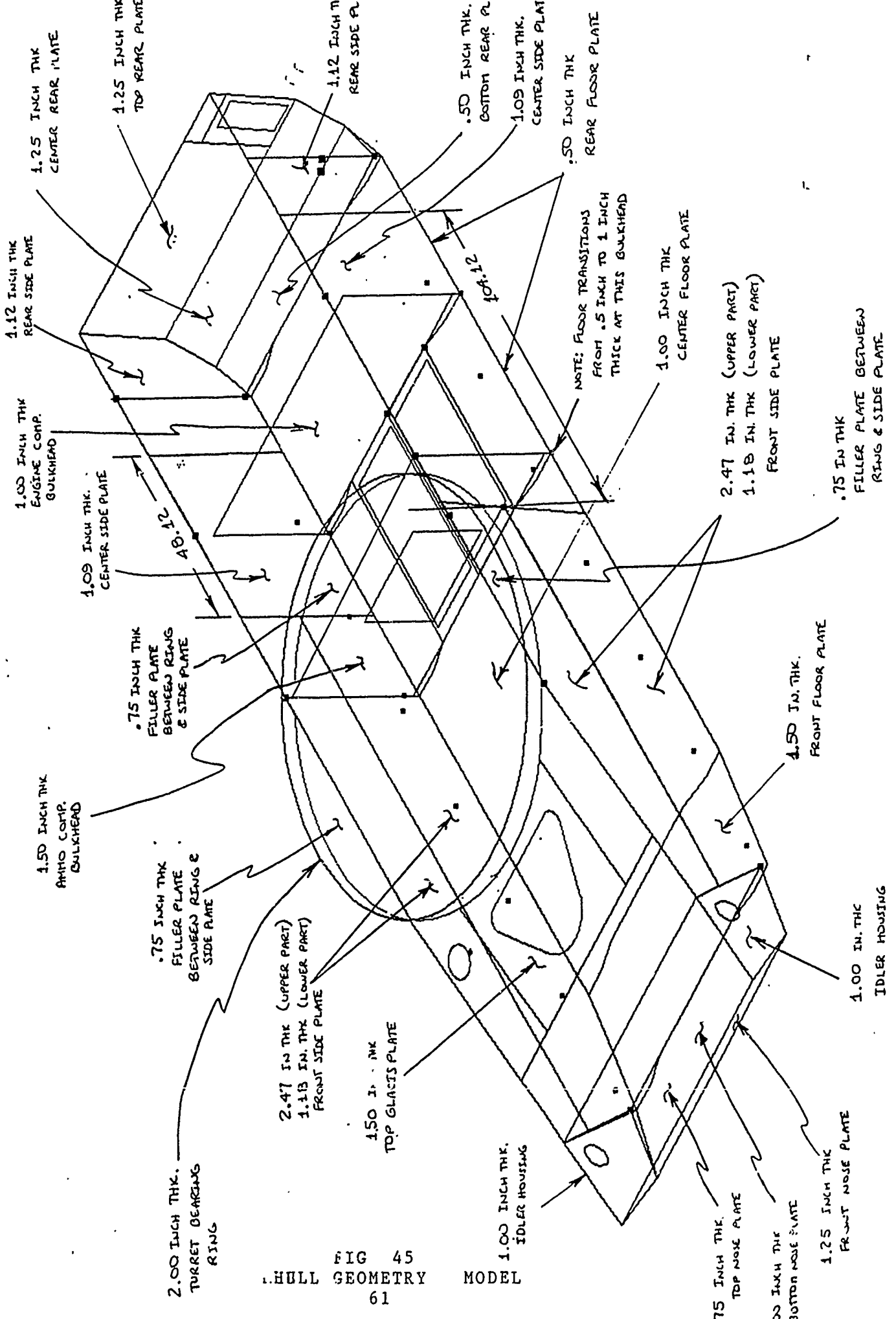

FIG 45
 HULL GEOMETRY MODEL
 61

1.25 INCH THK
 CENTER REAR PLATE

1.25 INCH THK
 TOP REAR PLATE

1.12 INCH THK
 REAR SIDE PL

.50 INCH THK.
 BOTTOM REAR PL

1.09 INCH THK.
 CENTER SIDE PLAT

.50 INCH THK
 REAR FLOOR PLATE

1.12 INCH THK
 REAR SIDE PLATE

NOTE: FLOOR TRANSITIONS
 FROM .5 INCH TO 1 INCH
 THICK AT THIS BULKHEAD

1.00 INCH THK
 CENTER FLOOR PLATE

2.47 IN. THK (UPPER PART)
 1.18 IN. THK (LOWER PART)
 FRONT SIDE PLATE

.75 IN THK
 FILLER PLATE BETWEEN
 RING & SIDE PLATE

1.00 INCH THK
 ENGINE COMP.
 BULKHEAD

1.09 INCH THK.
 CENTER SIDE PLATE

.75 INCH THK
 FILLER PLATE
 BETWEEN RING
 & SIDE PLATE

1.50 IN. THK.
 FRONT FLOOR PLATE

1.50 INCH THK
 AMMO COMP.
 BULKHEAD

.75 INCH THK
 FILLER PLATE
 BETWEEN RING &
 SIDE PLATE

2.47 IN THK (UPPER PART)
 1.18 IN. THK (LOWER PART)
 FRONT SIDE PLATE

1.50 IN. THK
 TOP GLACIS PLATE

1.00 INCH THK.
 IDLER HOUSING

1.00 IN. THK
 IDLER HOUSING

2.00 INCH THK.
 TURRET BEARING
 RING

.75 INCH THK.
 TOP NOSE PLATE

1.00 INCH THK
 BOTTOM NOSE PLATE

1.25 INCH THK
 FRONT NOSE PLATE

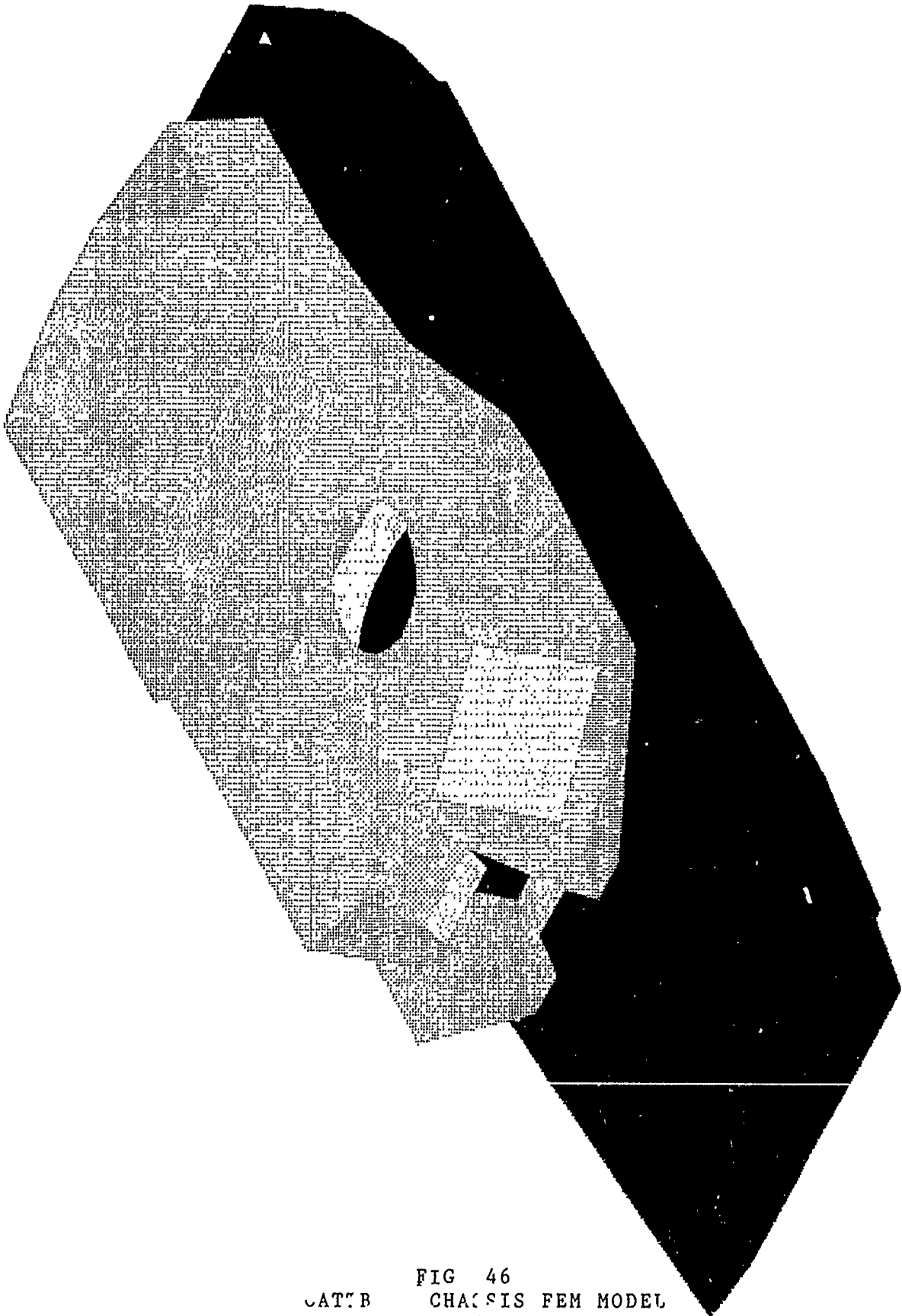

CAT7B FIG 46
 CHASSIS FEM MODEL
 62

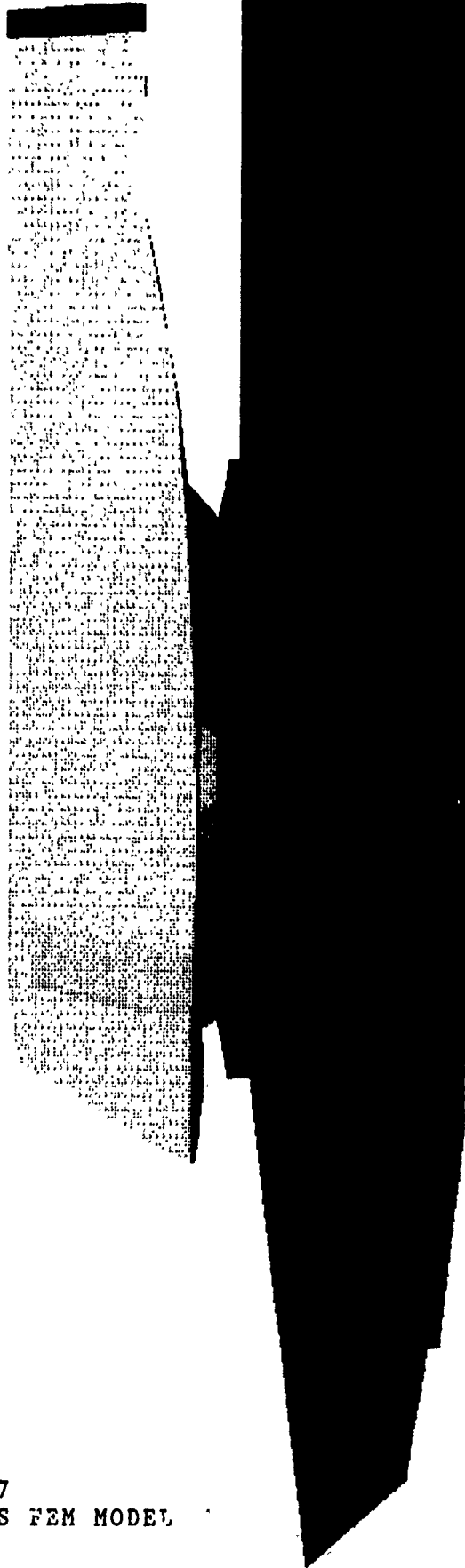

FIG 47
CATTB CHASSIS FEM MODEL
63

ENGINEERING DESIGN DIVISION
CATTB STRESS ANALYSIS
G + FIRING AT θ H -101

VM STRESS
(P.S.I.)



FIG 48
STRESS IN CATTB CHASSIS (GUN FIRING IN NORMAL POSITION)

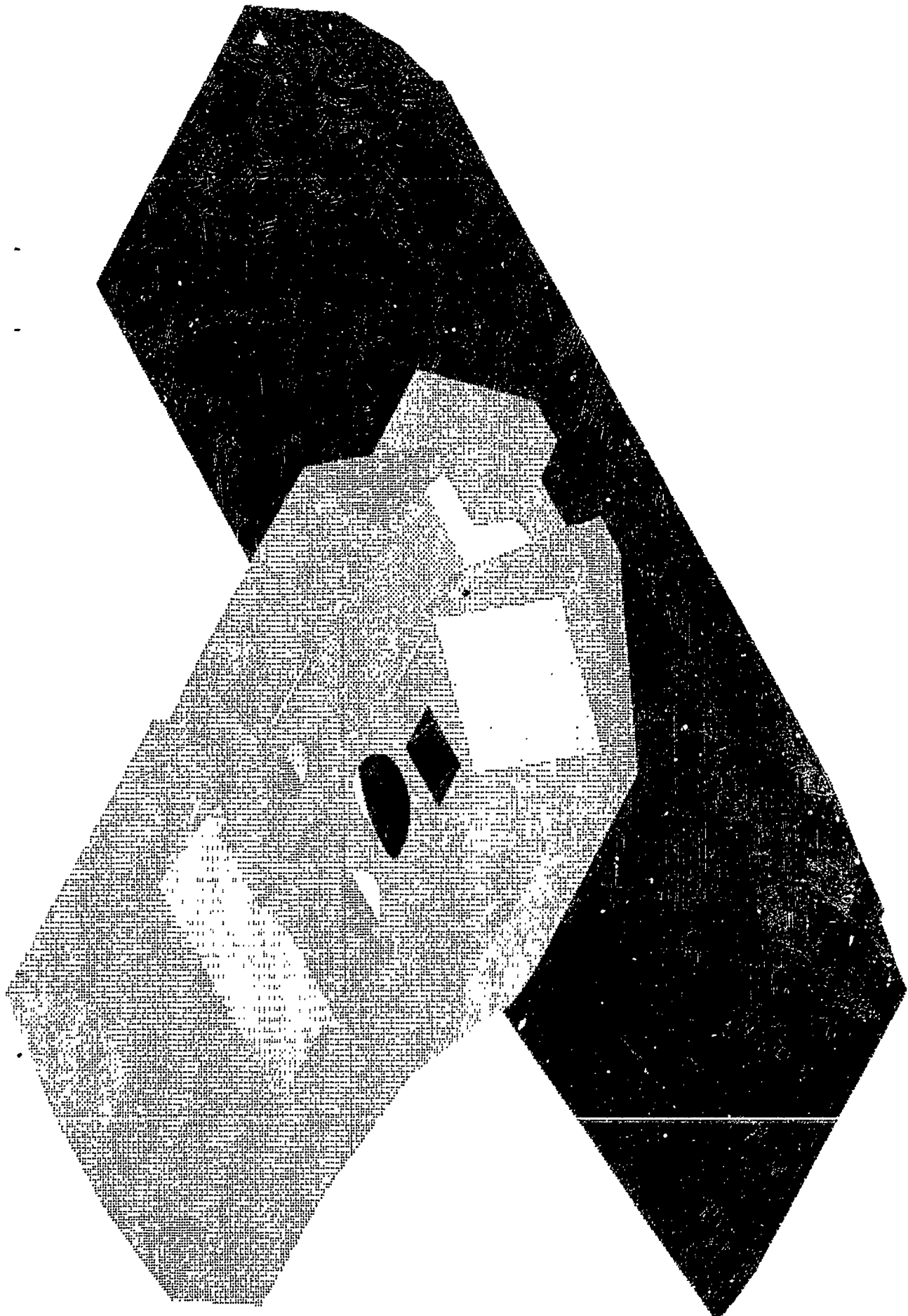
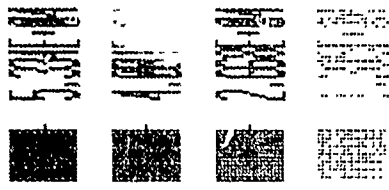
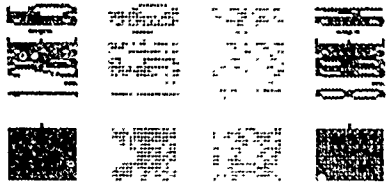
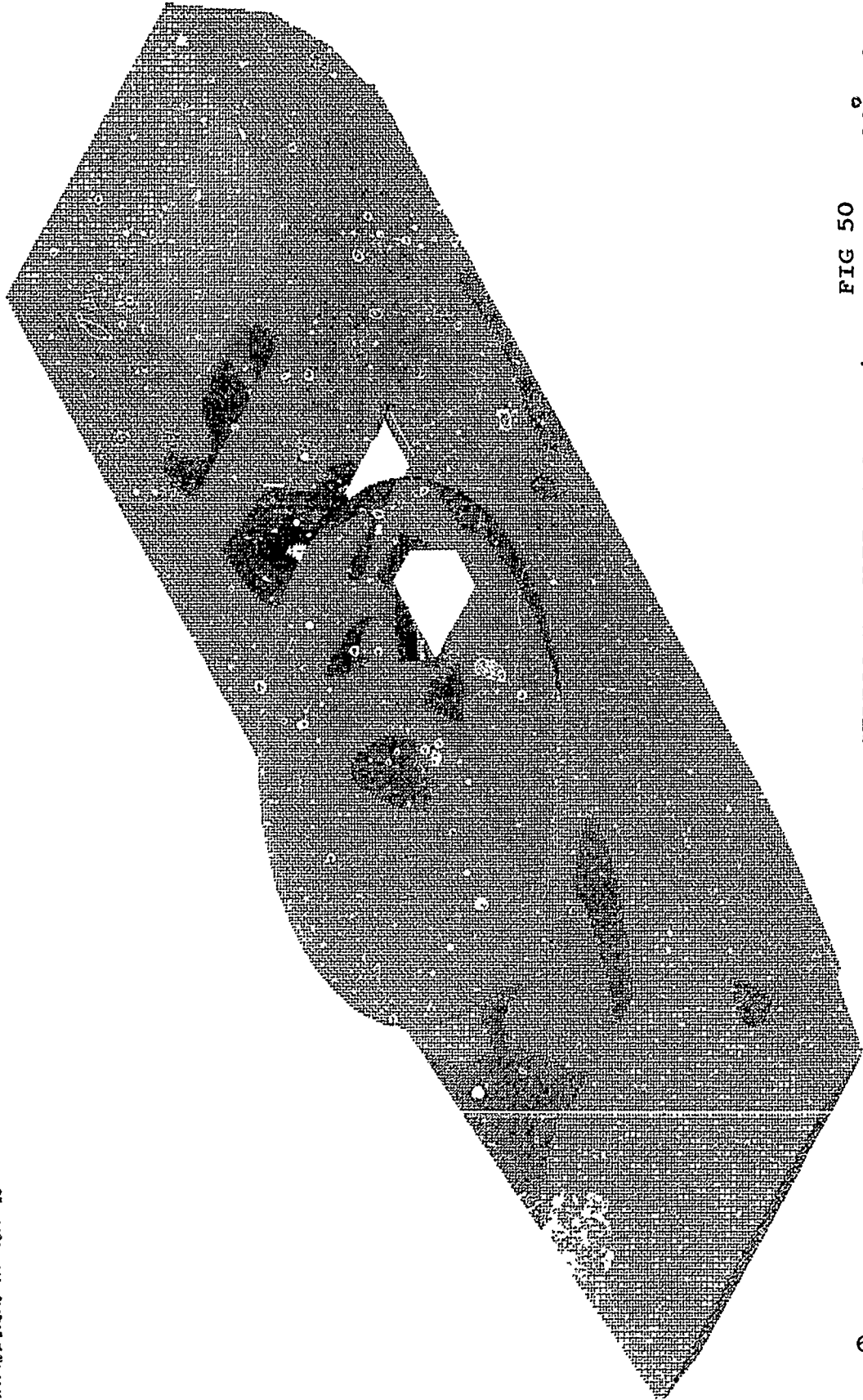

FIG 49
CATIB CHASSIS FEM MODEL (TURRET ROTATED 90°)

DESIGN DIVISION
STRUCTURES BRANCH
ATTENDING AT 984-107

VN STRESS
P.S.I.



WELDED JOINT

FIG 50
STRESS IN CATPB CHASSIS (GUN FIRING AT 90° - 2 RW ARE FIXED)

DESIGN DIVISION
STRUCTURES BRANCH
CATTS#IRING AT 984-104

VM STRESS
(P.50)

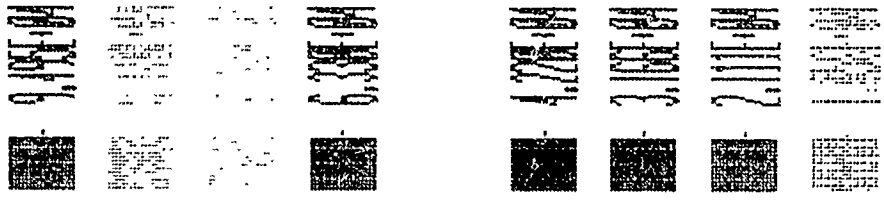

100000
100000
100000
100000
100000
100000
100000

FIG 51
STRESS IN CATTB CHASSIS
(GUN FIRING AT 90° - 7 RW ARE FIXED)

DESIGN DIVISION
STRUCTURES BRANCH
ATTB:FIRING AT 90H - 10V

LATERAL DEF
(IN)

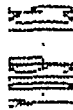
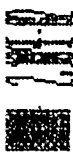
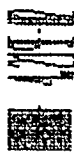
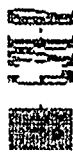
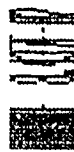
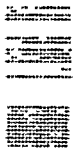

FIG 52
DEFLECTIONS IN CATB CHASSIS
(GUN FIRING AT 90° - 7 RW ARE FIXED)

DESIGN DIVISION
STRUCTURES BRANCH

CATTB: FIRING AT 90H - 10V

DEFORMED SHAPE

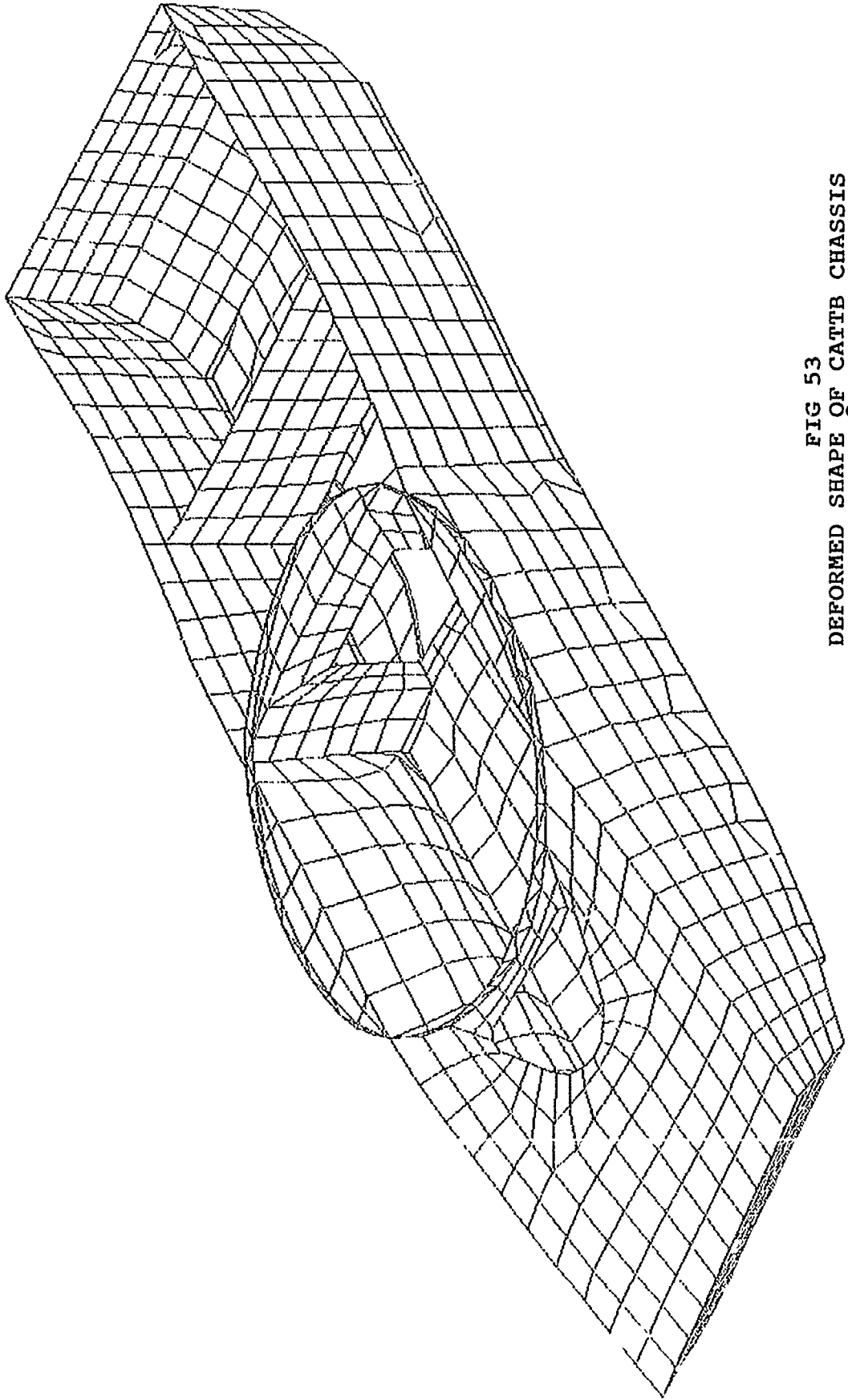

FIG 53
DEFORMED SHAPE OF CATTB CHASSIS
(GUN FIRING AT 90° - 7 RW ARE FIXED)

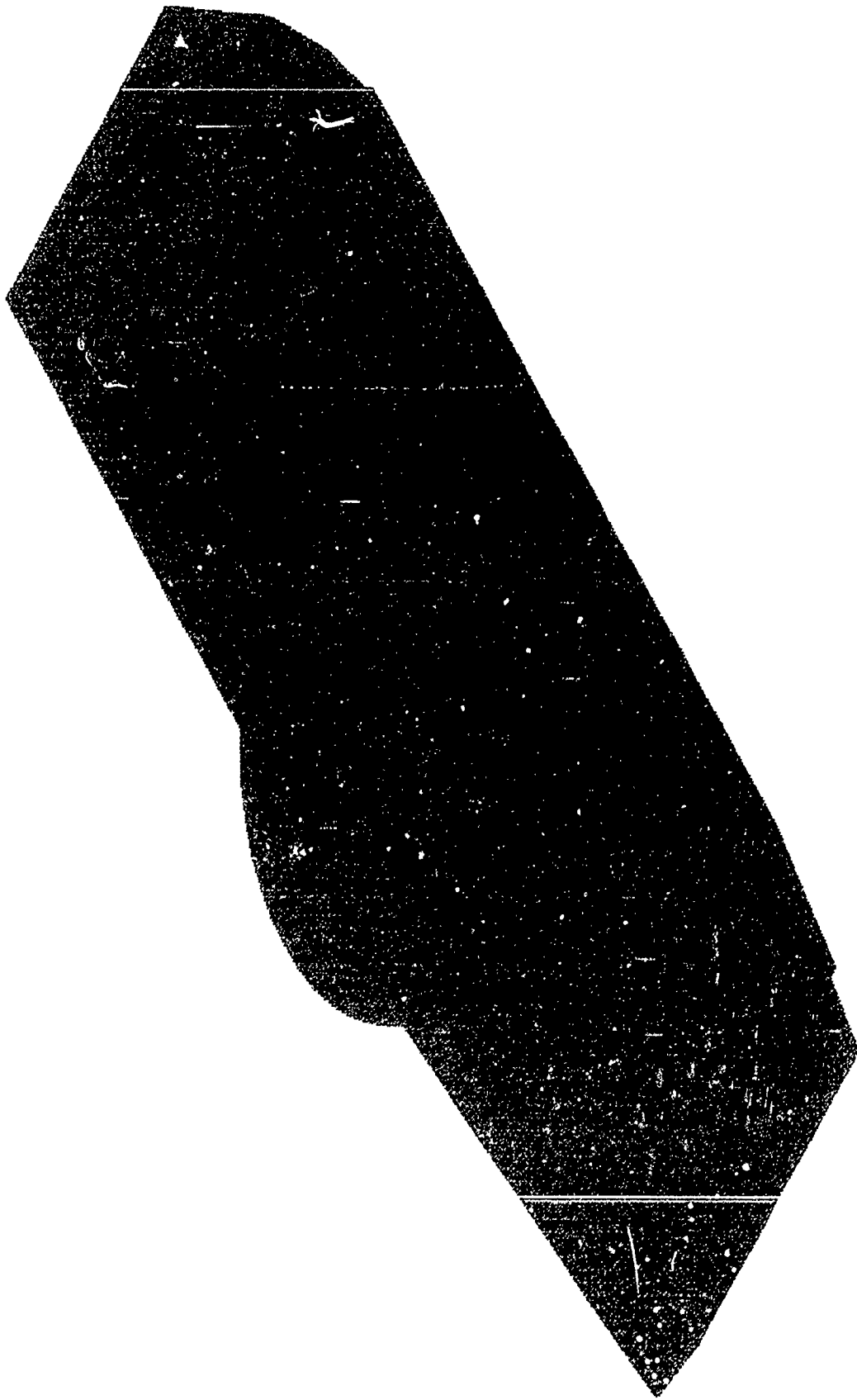

FIG 54
CATTB HULL FEM MODEL (MODIFICATION 1)

ENGINEERING DESIGN DIVISION
STRUCTURES BRANCH

CATTB: 2G + FIRING AT 90H -10V

VM STRESS
(P.S.I.)

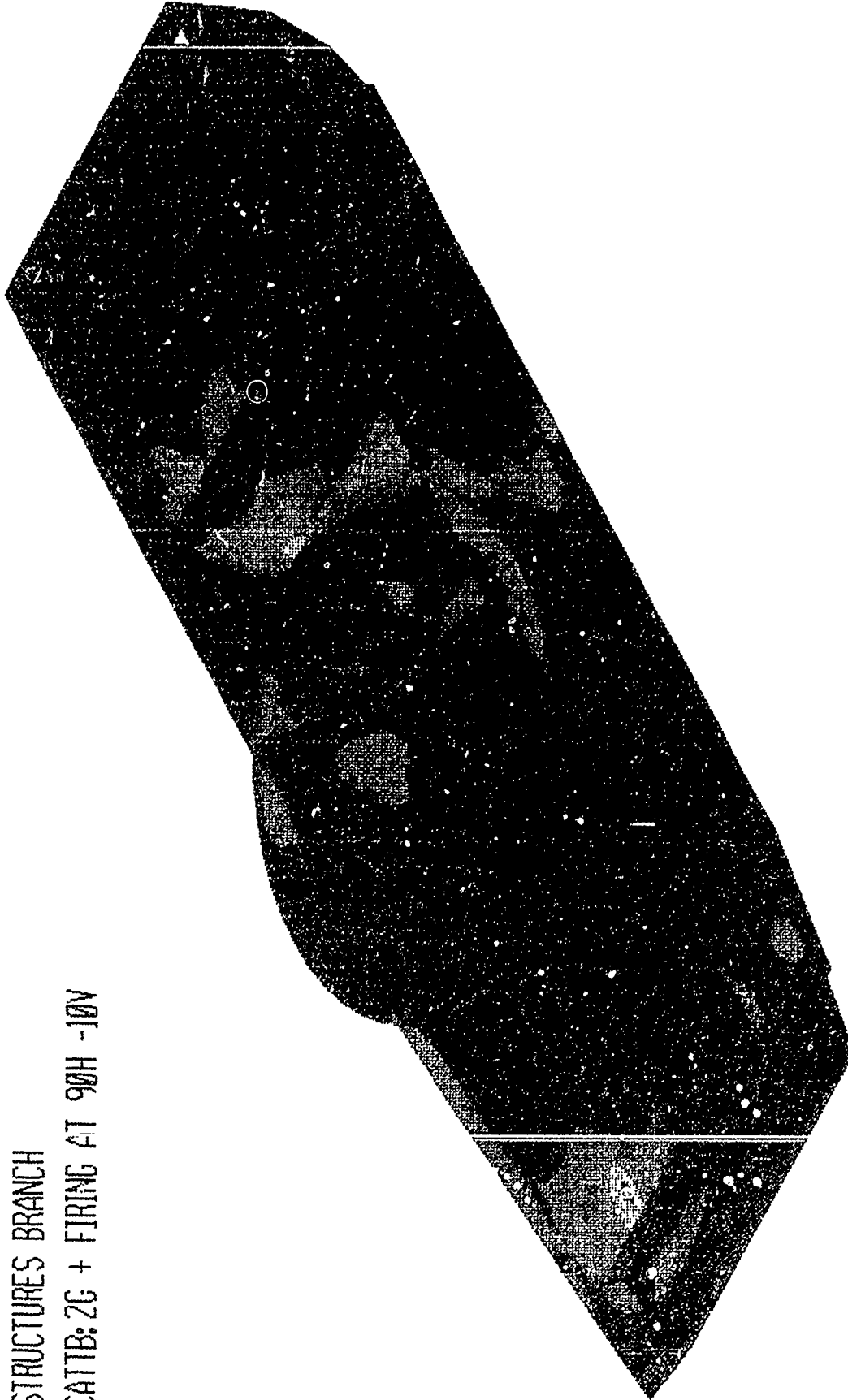
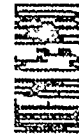
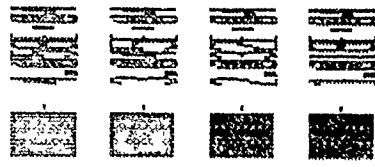
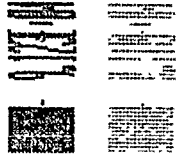
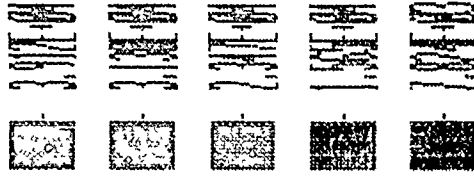

FIG 55
STRESSES IN MODIFIED (1)CATTB HULL
(GUN FIRING AT 90° -- 2 RW ARE FIXED)

ENGINEERING DESIGN DIVISION
STRUCTURES BRANCH
CATTB: 2G + FIRING AT 90H - 10V
(SEVEN ROAD WHEEL FIXED)

VM STRESS
(P.S.I.)

10000
5000
0
-5000
-10000



10000
5000
0
-5000
-10000

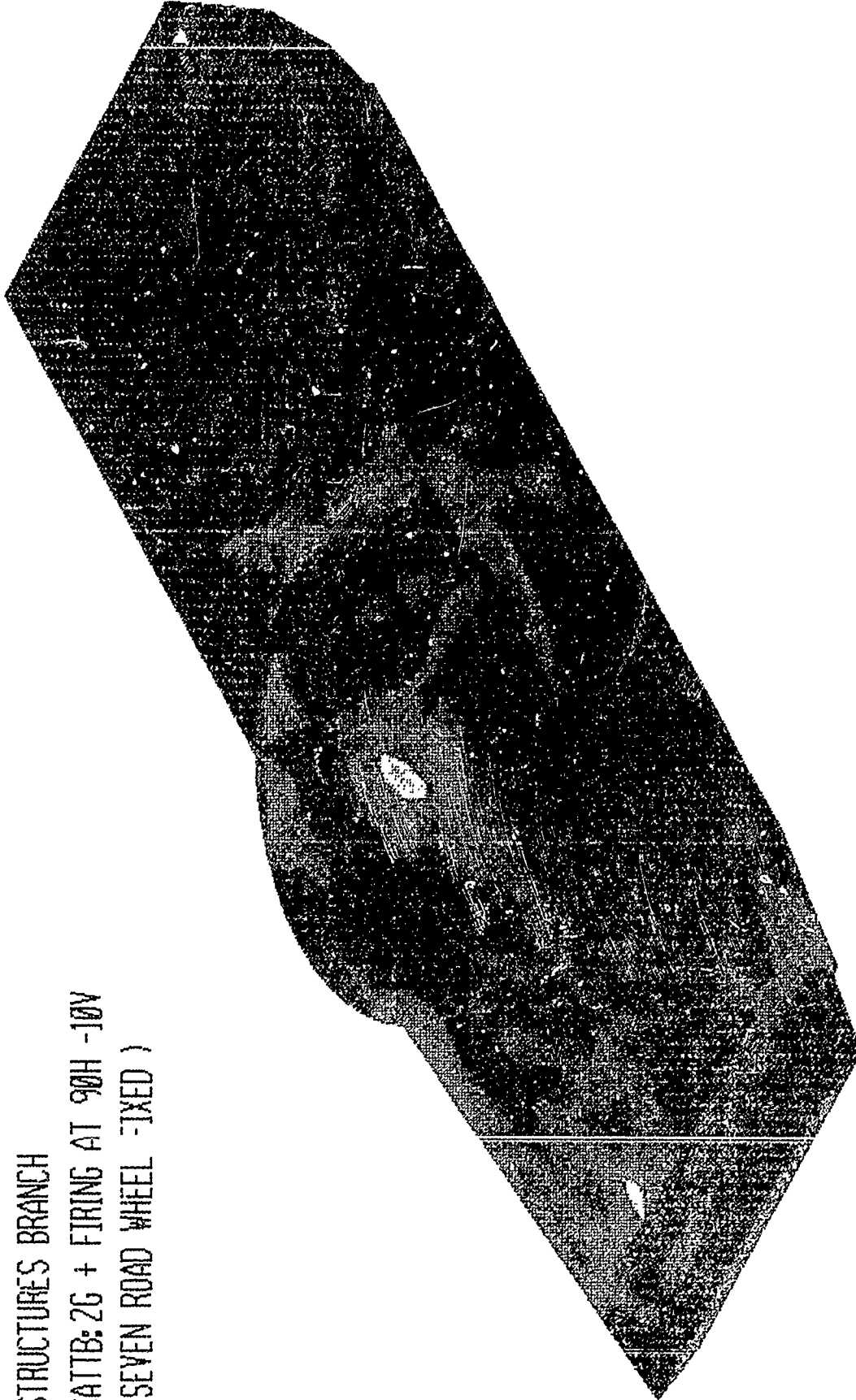

FIG 56
STRESSES IN MODIFIED (1) CATTB HULL
(GUN FIRING AT 90° - 7 RW ARE FIXED)

ENGINEERING DESIGN DIVISION
STRUCTURES BRANCH

CATTB: 2G + FIRING AT 90H - 1/2'

HORIZ DEF
(IN)

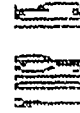
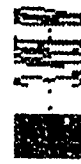
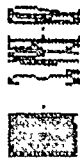
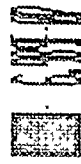
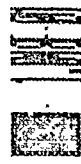
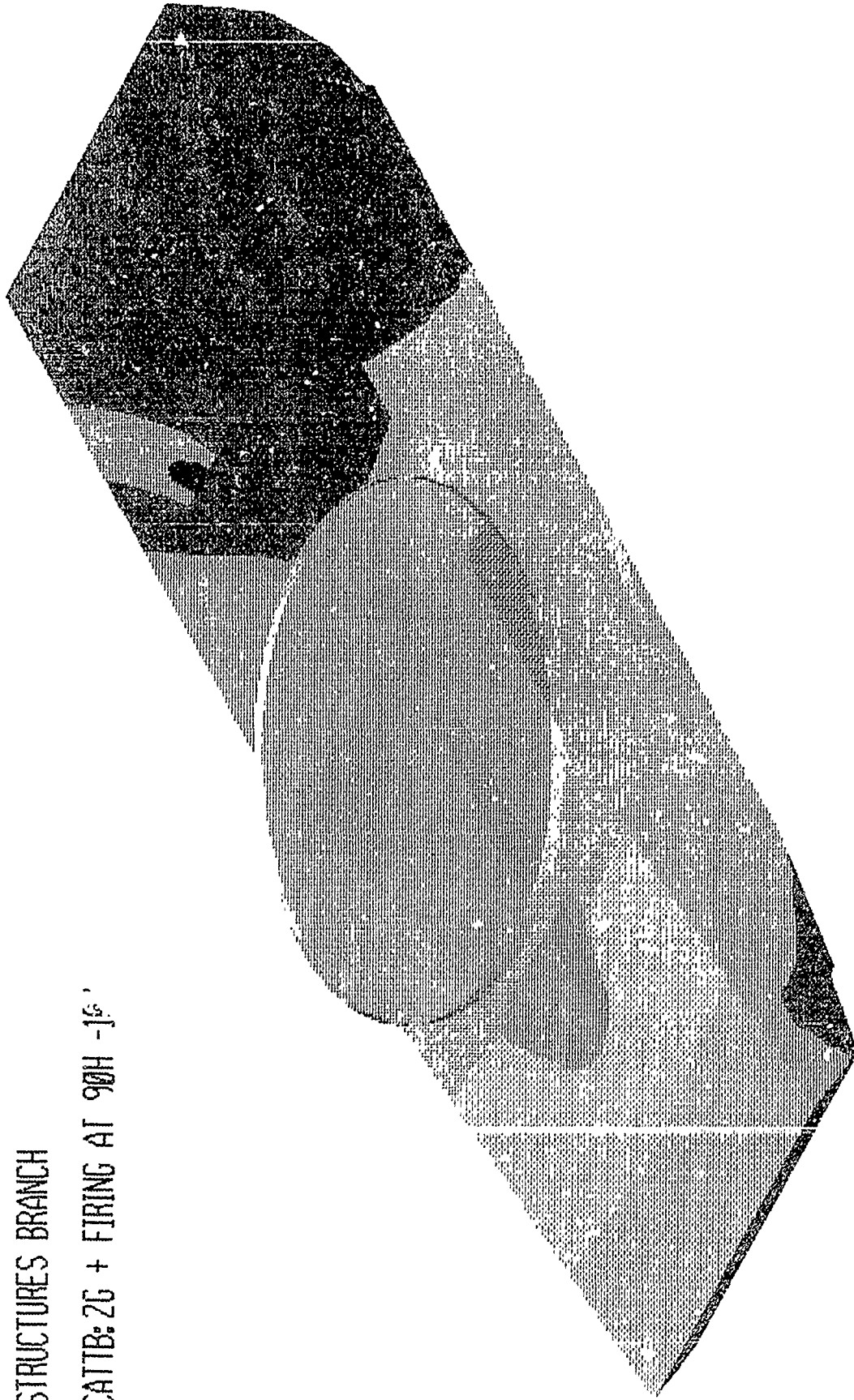

FIG 57
DEFLECTION IN MODIFIED (1) CATTB HULL
(GUN FIRING AT 90° - 2 RW ARE FIXED)

ENGINEERING DESIGN DIVISION
 STRUCTURES BRANCH
 CATTB: 2G-FIRING AT 90H -10Y
 (SEVEN ROAD WHEELS ARE FIXED)

HORZ DEF (IN)

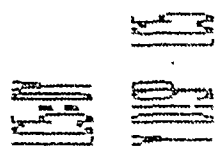
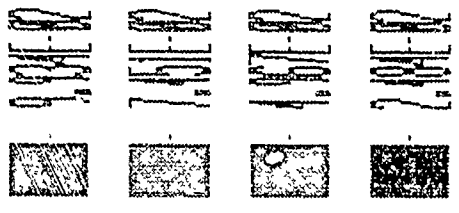
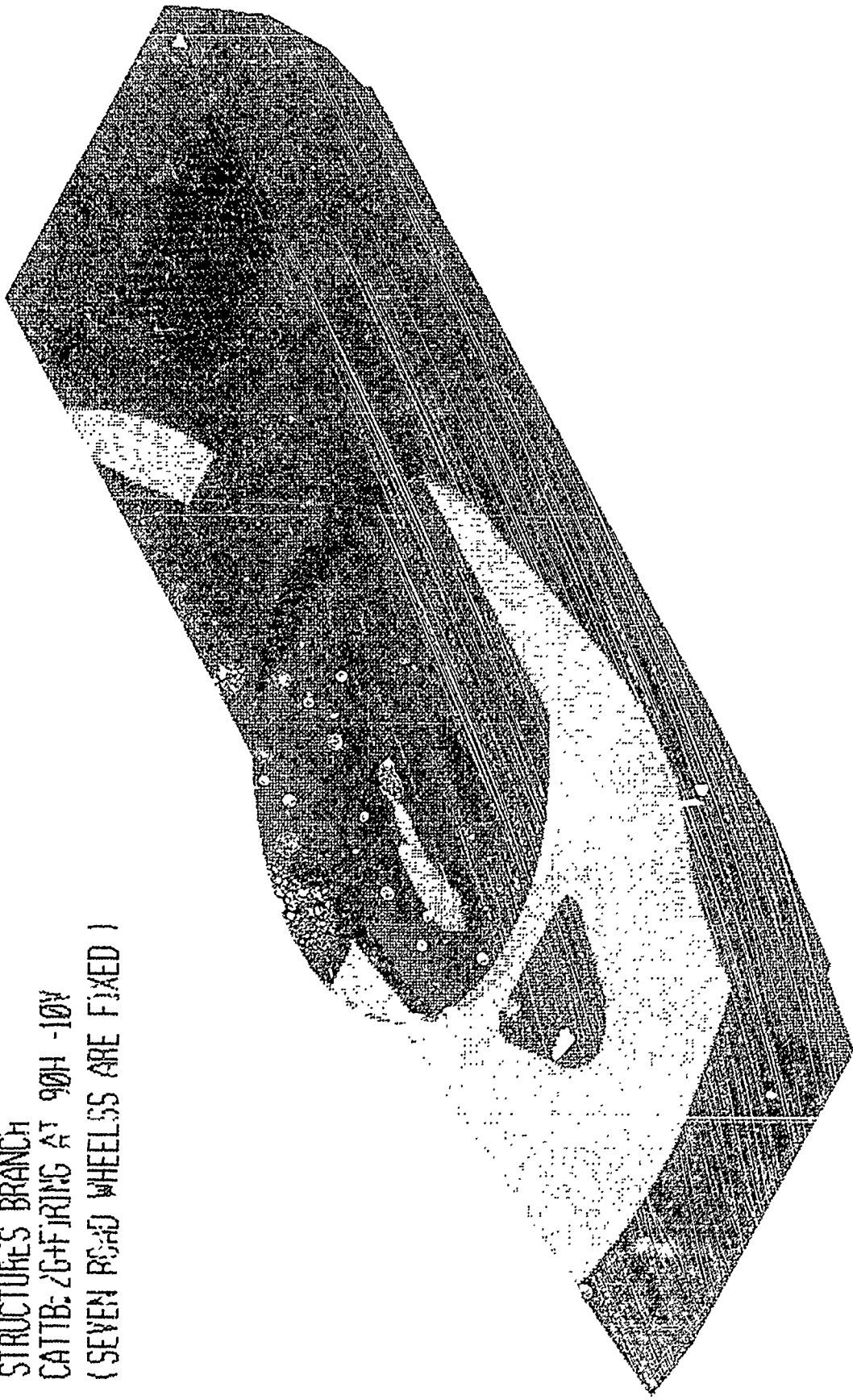

FIG 58
 DEFLECTION IN MODIFIED (1)CATTB HULL
 (GUN FIRING AT 90° - 7 RW ARE FIXED)

ENGINEERING DESIGN DIVISION
 STRUCTURES BRANCH
 CATTB: 2G + FIRING AT 90H - 10V
 (TOP PLATE AT REAR CASTING ADDED)

VM STRESS (PSI)

25000
 20000
 15000
 10000
 5000
 0

25000
 20000
 15000
 10000
 5000
 0

25000
 20000
 15000
 10000
 5000
 0



FIG 59
 STRESSES IN MODIFIED (2)CATTB HULL
 (GUN FIRING AT 90° - 7 RW ARE FIXED)

ENGINEERING DESIGN DIVISION
STRUCTURES BRANCH
CATTB: 2G + FIRING AT 90H - 10V

LATREAL DEF (IN)

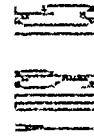
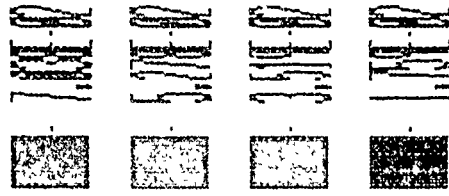
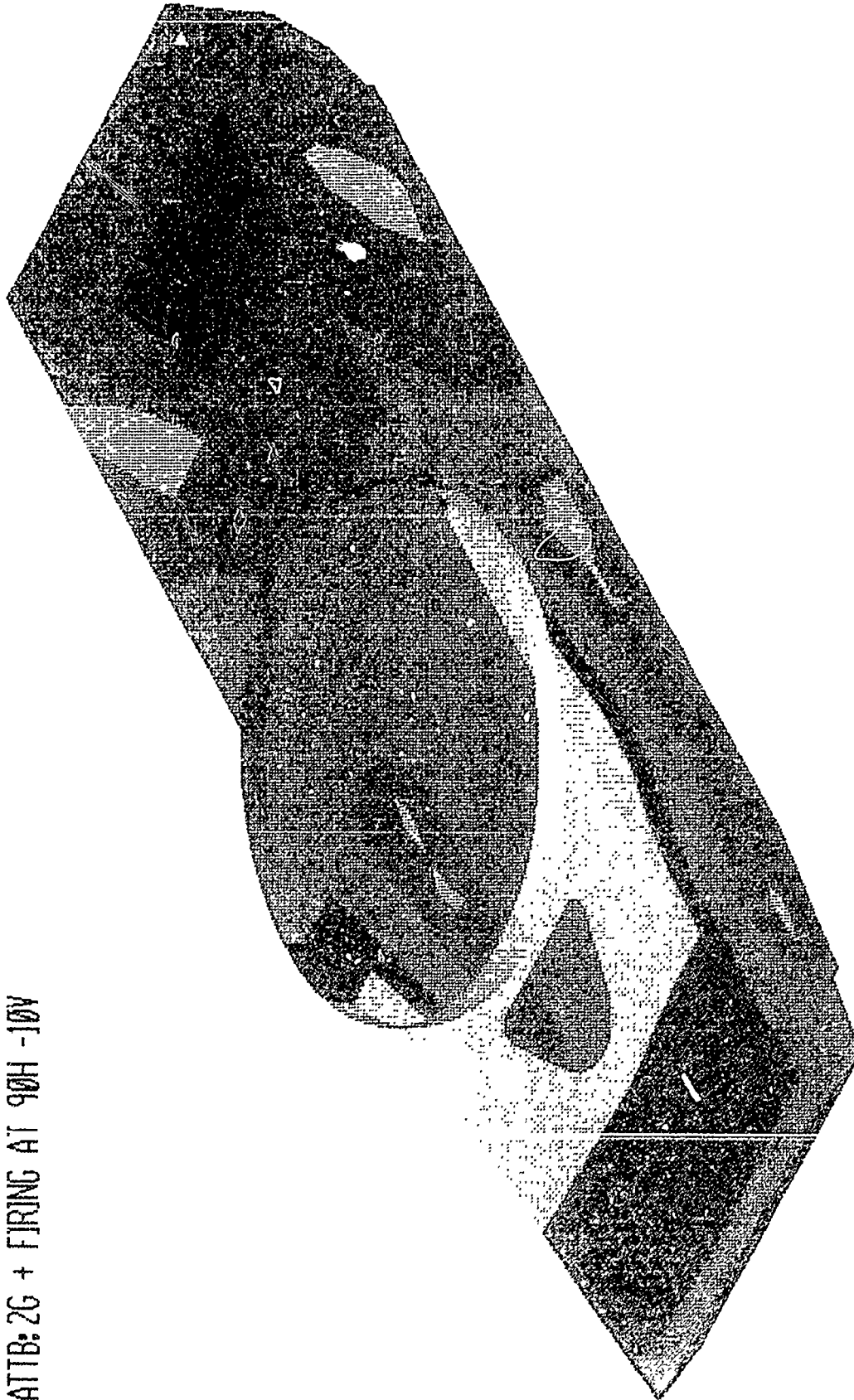
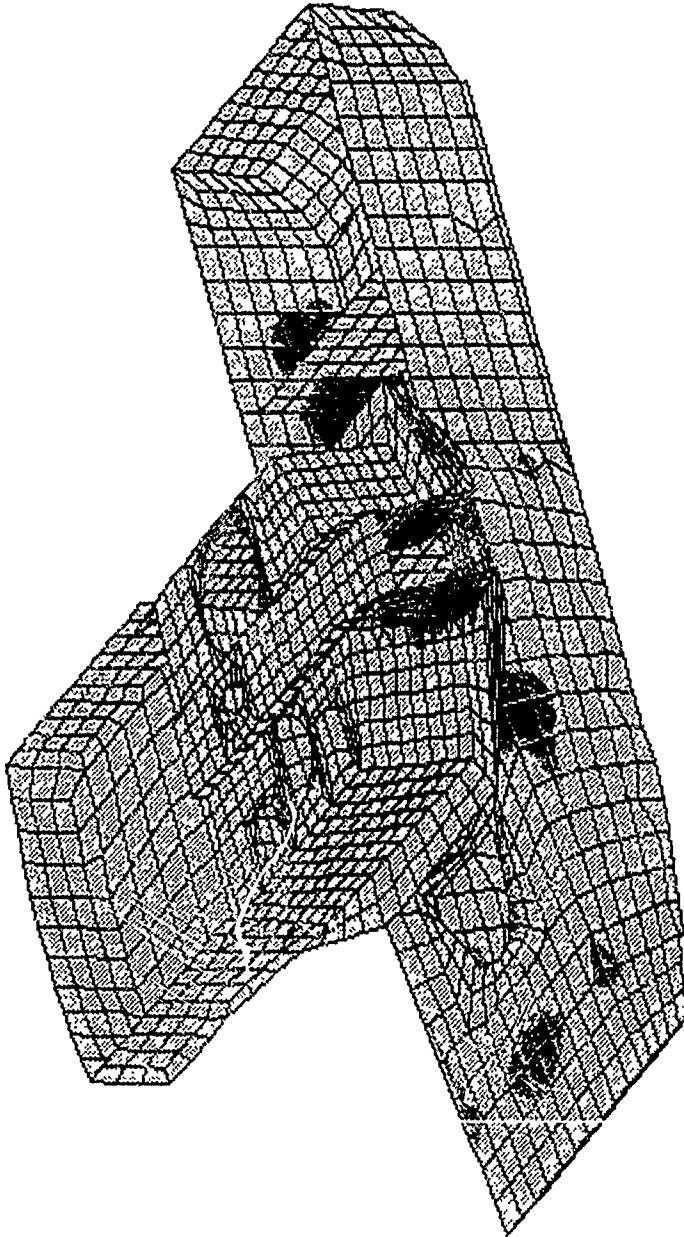

FIG 60
DEFLECTIONS IN MODIFIED (2)CATTB HULL
(GUN FIRING AT 90° - 7 RW ARE FIXED)

STRESS CONTOURS
VDN-MISES STRESS
VIEW : 1.91E+01
RANGE : 8.00E+04
(Band * 1.0E2)



EMRC-NISA-DISPLAY

RX= -60
RY= 0
RZ= 30

CATTB NEUTRAL FILE FROM PATRAN

TOP LAYER

FIG 61
STRESSES IN MODIFIED (3)CATTB HULL
(GUN FIRING AT 90° - 7 RW ARE FIXED)

E.M.R.C.- DISPLAY II POST-PROCESSOR: VERSION 89.0 Dec/20/89

STRESS CONTOURS
VDN-MISES STRESS
VIEW : 1.91E+01
RANGE : 3.06E+04
(Band * 1.0E2)

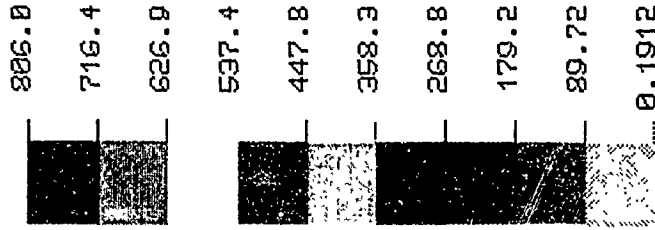
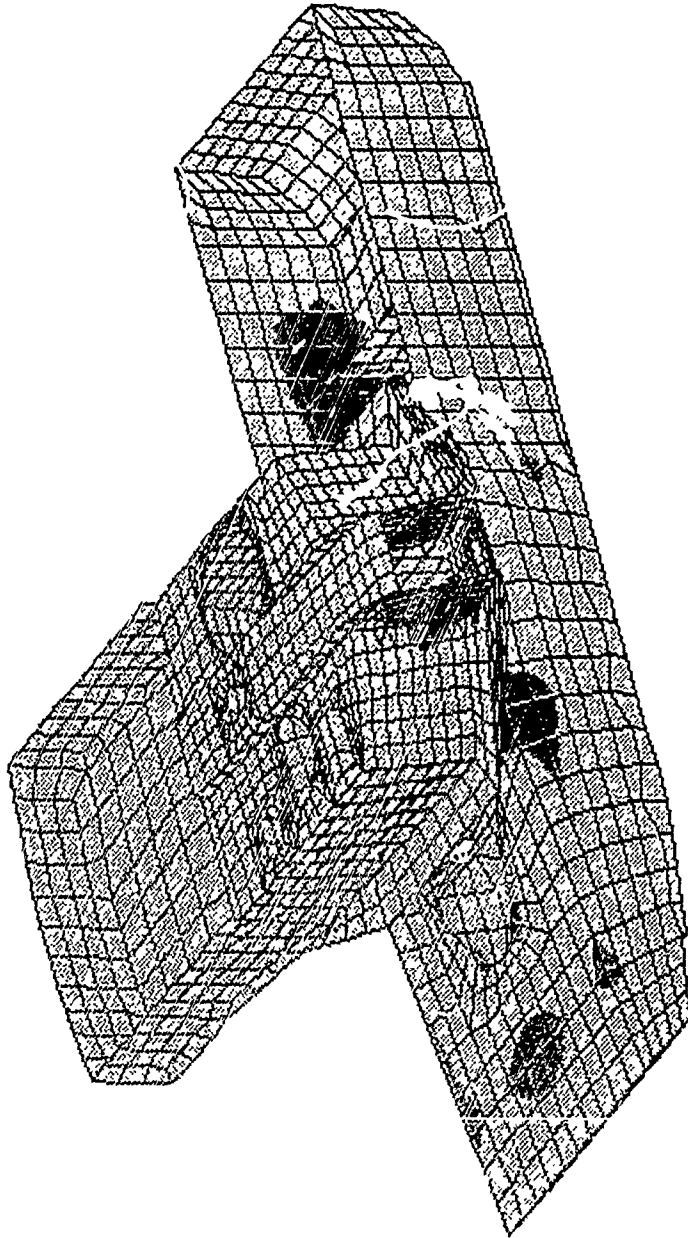

EMRC-NISA/DISPLAY

RX= -60
RY= 0
RZ= 30



CATTB NEUTRAL FILE FROM PATRAN
TOP LAYER

FIG 62
STRESSES IN MODIFIED (3)CATTB HULL
(GUN FIRING AT 90° - 7 RW ARE FIXED)

E.M.R.C.- DISPLAY II POST-PROCESSOR VERSION 89.0 Jan/ 5/90

STRESS CONTOURS
 VON-MISES STRESS
 VIEW : 2.17E+01
 RANGE : 8.10E+04
 (Band * 1.0E2)

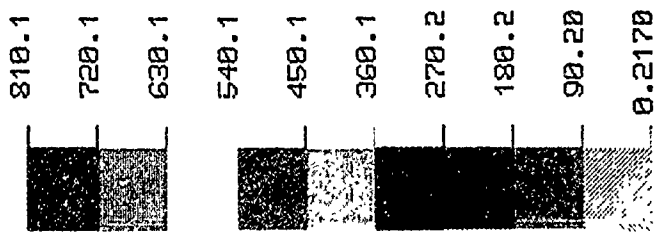
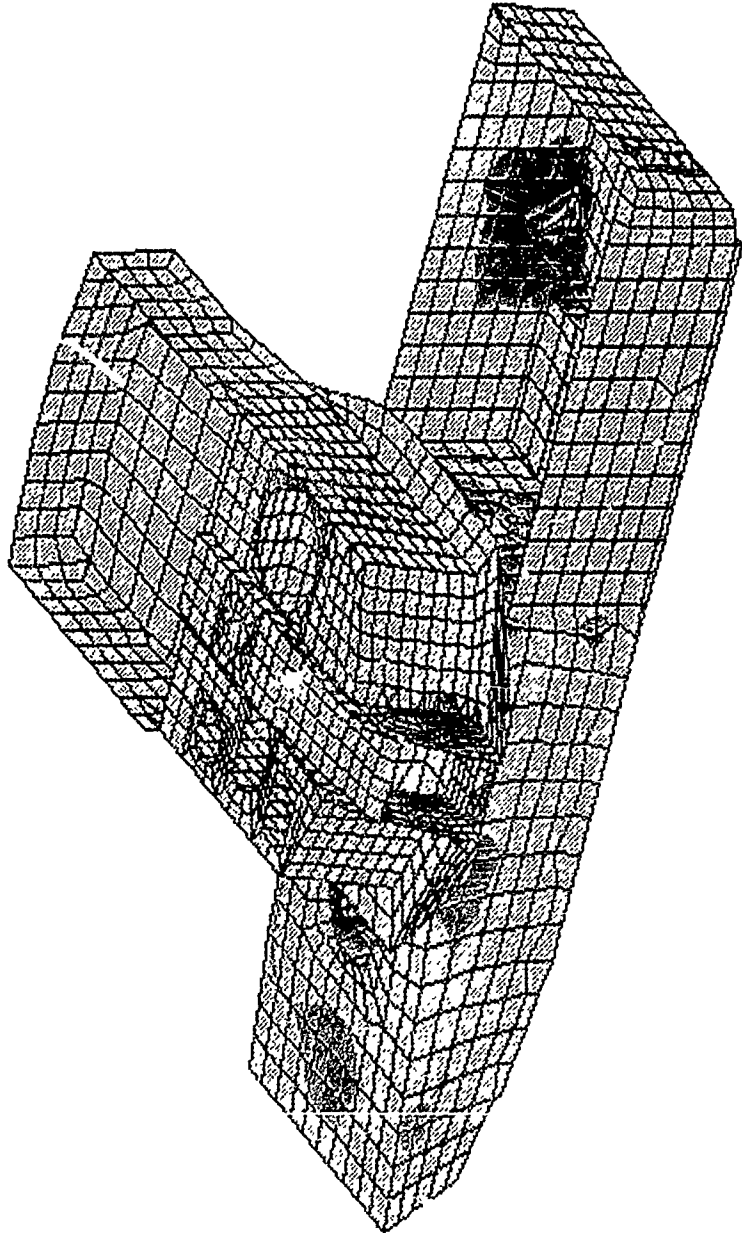

EMRC-NISA/DISPLAY

RX= -60
 RY= 0
 RZ= -30

CATB NEUTRAL FILE FROM PATRAN
 BOTTOM LAYER

FIG 63
 STRESSES IN MODIFIED (3)CATB HULL
 (GUN FIRING AT 90 - 7 RW ARE FIXED)

E.M.R.C.- DISPLAY II POST-PROCESSOR VERSION 89.0 Dec/18/89

DISPL. CONTOURS
Y - DISPLACEMENTS
VIEW : -3.28E-02
RANGE : 3.19E-01

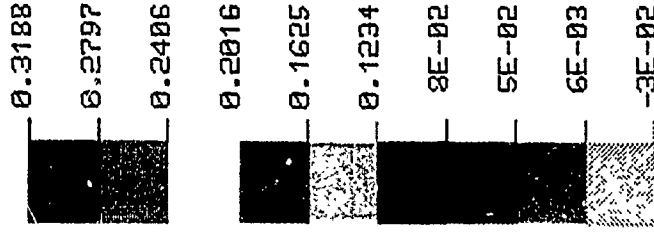
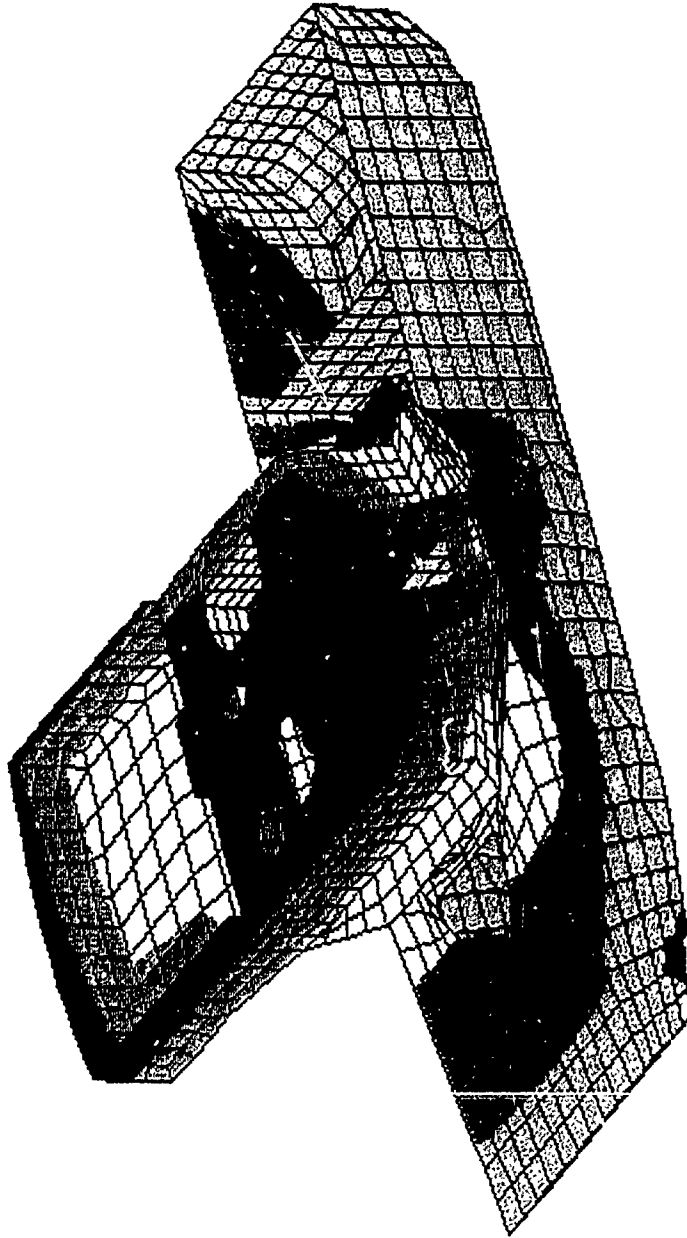

EMRC-NISA/DISPLAY

RX= -60
RY= 0
RZ= 30

A small diagram showing a 3D coordinate system with X, Y, and Z axes. The X-axis is horizontal, the Y-axis is vertical, and the Z-axis is diagonal.

CATTB NEUTRAL FILE FROM PATRAN

MIDDLE LAYER

FIG 64
DEFLECTIONS IN MODIFIED (3)CATTB HULL
(GUN FIRING AT 90° - 7 RW ARE FIXED)

E.M.R.C.- DISPLAY II POST-PROCESSOR VERSION 89.0 Dec/20/89

DISPL. CONTOURS
 Y - DISPLACEMENTS
 VIEW : -3.30E-02
 RANGE : 3.20E-01

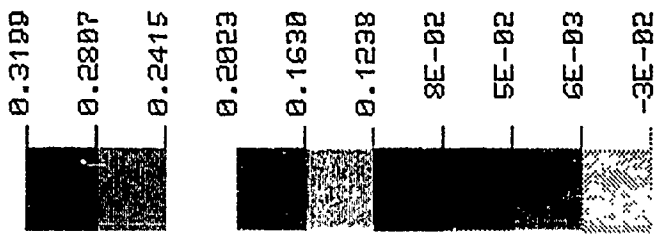
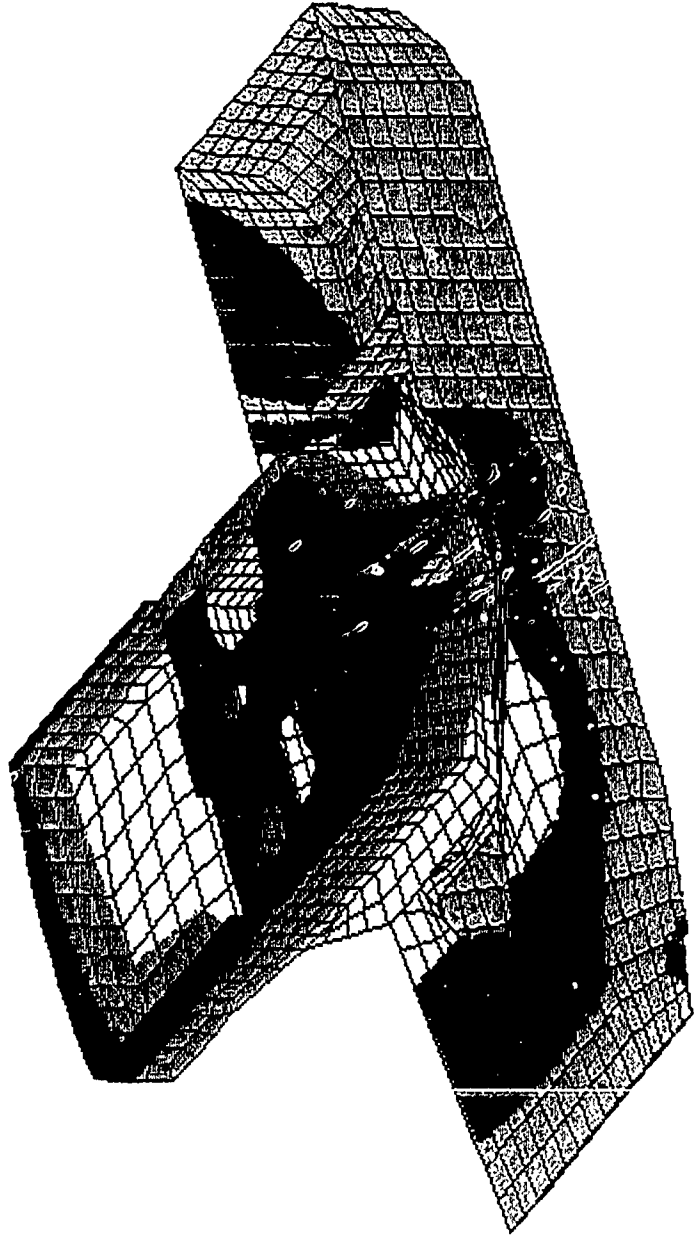

EMRC-NISA/DISPLAY

RX= -60
 RY= 0
 RZ= 30



CATB NEUTRAL FILE FROM PATRAN

FIG 65
 DEFLECTIONS IN MODIFIED (3)CATB HULL
 (GUN FIRING AT 90° - 7 RW ARE FIXED)

E.M.R.C.- DISPLAY II POST-PROCESSOR VERSION 89.0 Jan/ 3/90

DISPL. CONTOURS
 Y - DISPLACEMENTS
 VIEW : -3.38E-02
 RANGE : 3.25E-01

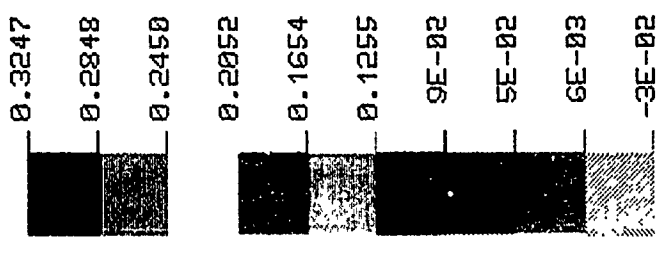
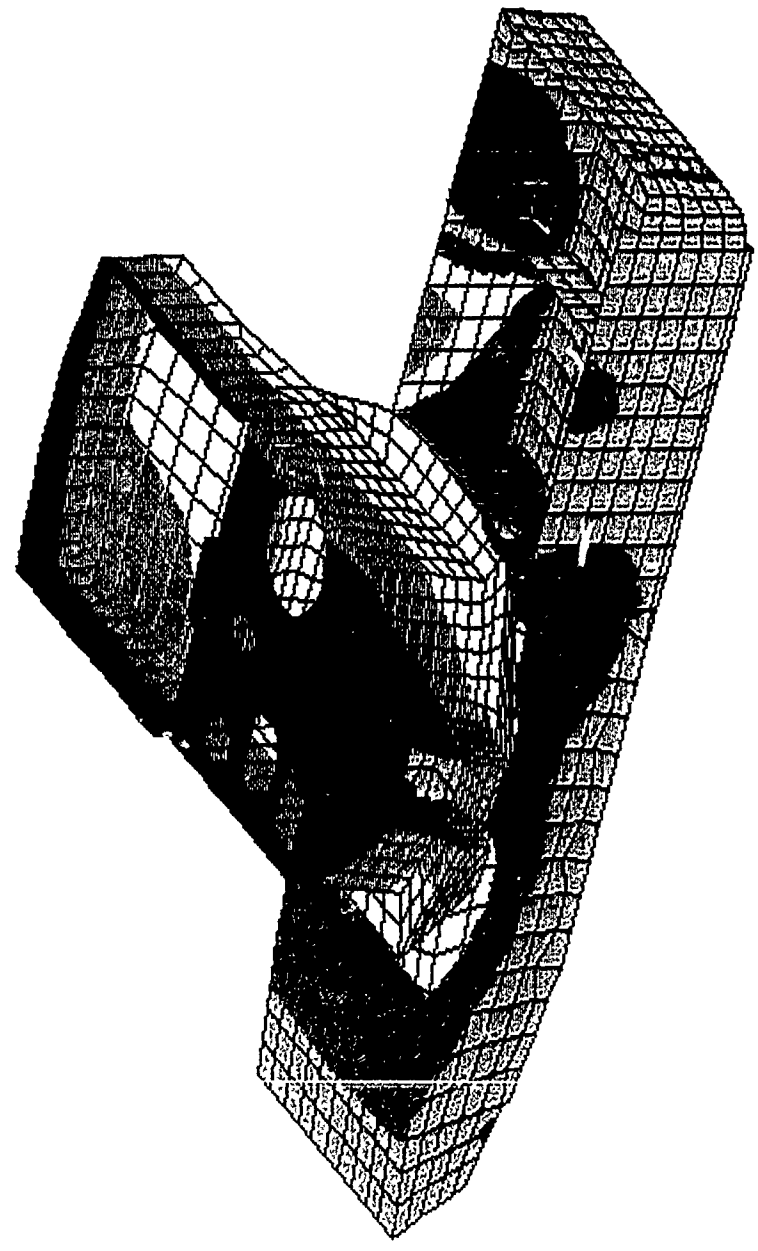

EMRC-NISA-DISPLAY

RX= -60
 RY= 0
 RZ= -30

CATTB NEUTRAL FILE FROM PATRAN
 BOTTOM LAYER

FIG 66
 DEFLECTION IN MODIFIED (3)CATTB HULL
 (GUN FIRING AT 90° - 7 RW ARE FIXED)

STRESS CONTOURS
OCTAHEDRAL STRESS
VIEW : 1.05E+01
RANGE : 3.82E+04

(Band * 1.0E2)

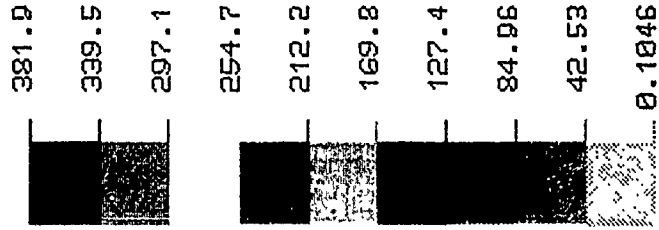
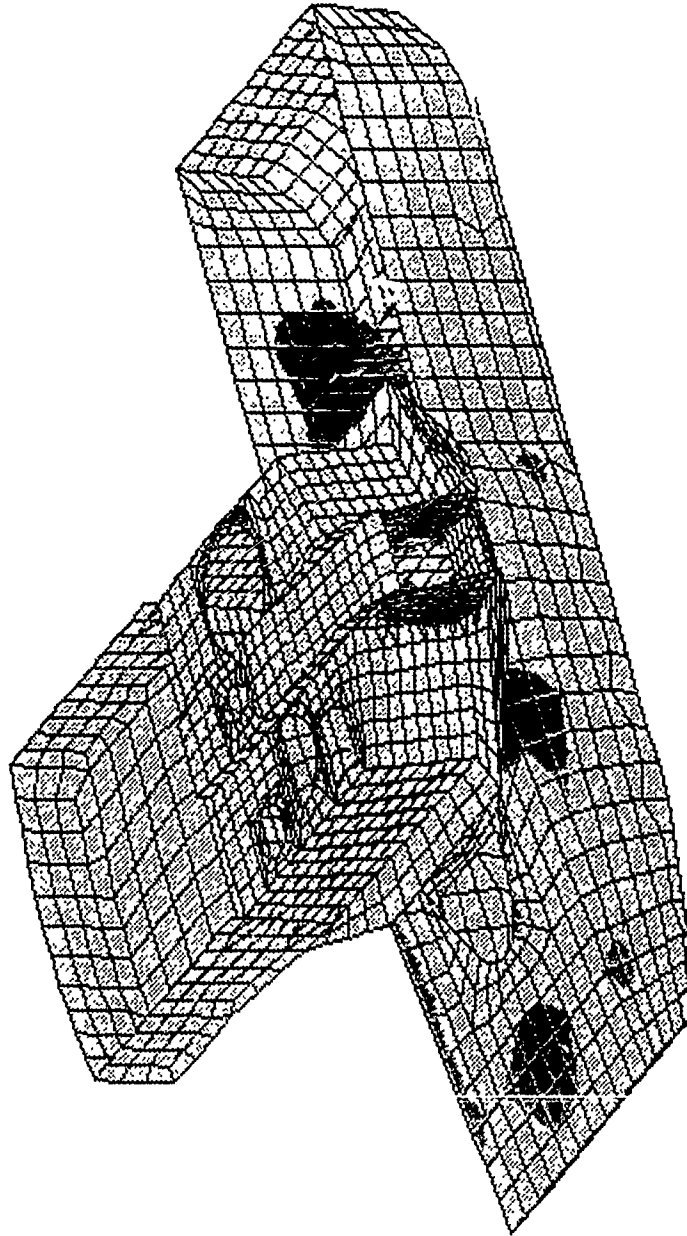

EMRC-NISA-DISPLAY

RX= -60
RY= 0
RZ= 30

A small diagram showing a 3D coordinate system with X, Y, and Z axes. The X-axis is horizontal, the Y-axis is vertical, and the Z-axis is diagonal.

FIG 67
SHEAR STRESS IN MODIFIED (3)CATTB HULL
(GUN FIRING AT 90° - 7 RW ARE FIXED)

E.M.R.C.- DISPLAY II POST-PROCESSOR VERSION 89.0 Dec/18/89

DISPLACED - SHAPE
MX. DEF- 4.29E-01
NODE NUMBER= 1737
SCALE = 2.0
(MAPPED SCALING)

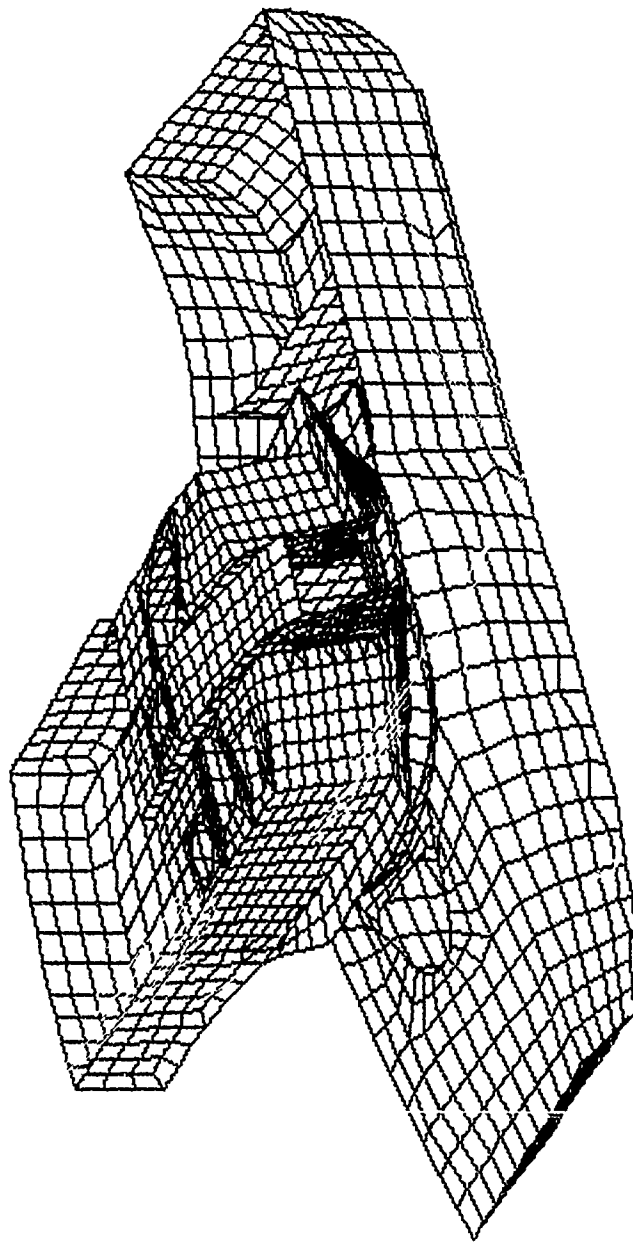

CATTB NEUTRAL FILE FROM PATRAN
MIDDLE LAYER



RX= -60
RY= 0
RZ= 30

FIG 68
DEFORMED SHAPE FOR CATTB CHASSIS
(GUN FIRING AT 90° - 7 RW ARE FIXED)

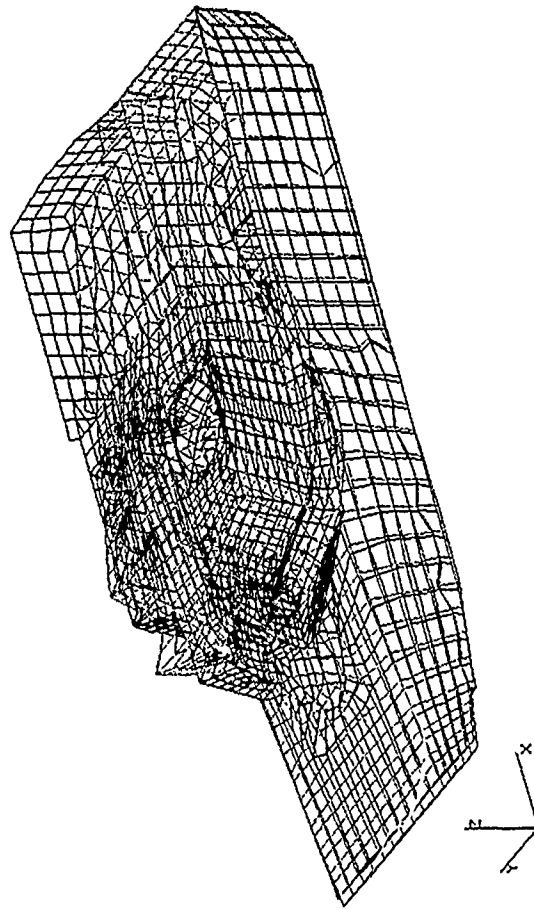

FIG 69
DEFORMED SHAPE FOR CATTB CHASSIS
(GUN FIRING AT NORMAL POSITION)

A separate finite element model was built exclusively to study the stress behaviour of the sponsons and skirts and to study the interaction between them and the outriggers. Sponson and skirt model consist of 720 plate elements (eight noded quad and 6 noded triangle), were used to model the outriggers, and 142 beam elements were used. Total number of the FEM active nodes for the whole model is 1136. Each node has six Degrees of freedom-three rotations and three translations. Thickness of the sponson plates are 0.50 in., whereas the skirts and the various bulkhead are 0.31 in. thick. The various outriggers consist of 1.5 in. Dia tube. The sponsons are constrained at the nodes coinciding with the location of the main side plates.

The load on the sponsons bottom plate consist of the weight of six batteries and the weight of the NBC unit and the various control boxes. This load is 800 lbs. and distributed over an area of 25 x 60 sq in. which represent a uniform pressure of 0.2 lb/in. To study the effect of acceleration effects, a mass density of 0.000732 slug/in. was used.

The finite element model was analyzed using IFEM available at the intergraph work station, because IRM is no longer available on the vax computer. To account for the various forces acting on the sponsons and skirts, a combined case of acceleration load of 12 G, 6 G, and 3 G in the longitudinal, vertical and lateral direction respectively was used.

Fig. (70) shows the finite element model including sponsons covers. The stress for the 1 G lateral case is 13,500 PSI, as shown in Fig. (71). The lateral displacement is 0.3 in., as shown in Fig. (72). The stress due to the compound acceleration is 122,500 PSI Fig. (73). Lateral and vertical deformations are in the range 3 to 4 in. as shown in Fig. (74 and 75). The deformed shape is shown in Fig. (76). It is obvious that stresses and deformations are excessive and the skirts had to be reinforced, this was accomplished by adding a 1.5 in. tube (3/16 in. thick) at the location of the first outrigger. Fig. (77 and 78) show the FEM model without the sponson cover plates. This model was analyzed under the same loading conditions; stresses and deformations were reduced substantially. For the 1 G lateral the stress is reduced to 13,400 PSI and the deflection to 0.4 in. as shown in Fig. (79 and 80). In the case of the combined acceleration, the stress is reduced to 41,000 PSI Fig. (81), and the deformations to 0.5 - 1.2 in. as shown in Fig. (82 and 83); the deformed shape is shown in Fig. (84). By comparison, adding the strut, the stresses and deformations were reduced by more than 70%.

Forces in the outriggers are maximum in the attachment bolt at rear skirt element no. 13 in Fig. (85) from which maximum stresses can be easily obtained as follows:

$$f = \frac{F_x}{A} + \frac{M_z}{S_z} + \frac{M_y}{S_y}$$

Where

f	Maximum Stress (PSI)
F _x	Axial Force (lbs)
A	Cross Section Area
S _y , S _z	Section Modulus About y and z axis
I _y , I _z	Moment of Inertia About y and z axis
M _y , M _z	Bending Moments About y and z axis

Applying above equation yields

$$\begin{aligned}
 f &= \frac{72}{0.78} + \frac{5770}{\frac{.05}{0.5}} + \frac{3485}{\frac{.05}{0.5}} \\
 &= 90 + 57,690 + 34,850 \\
 &= 92,630 < F_y = 100,000 \text{ PSI}
 \end{aligned}$$

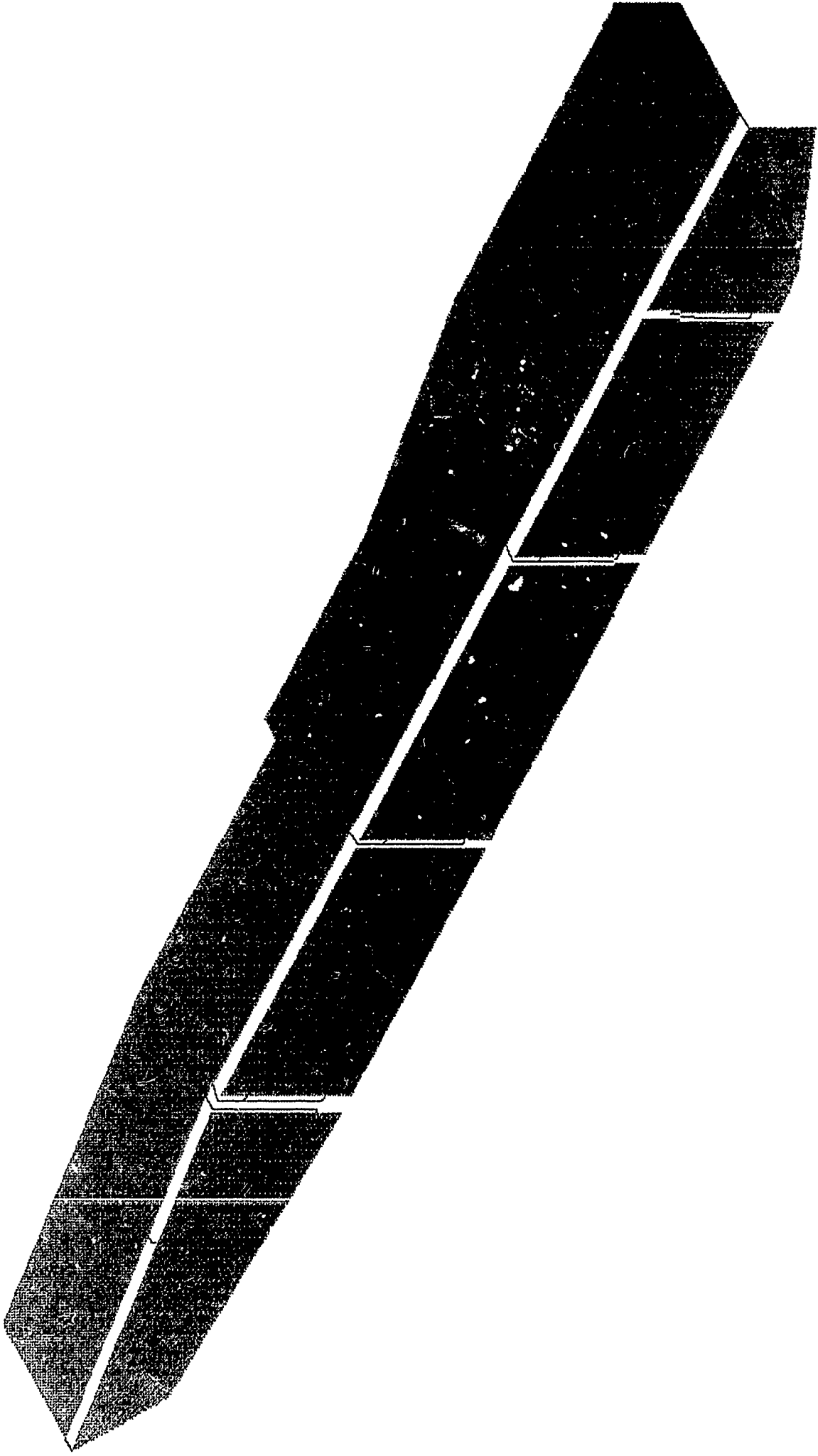
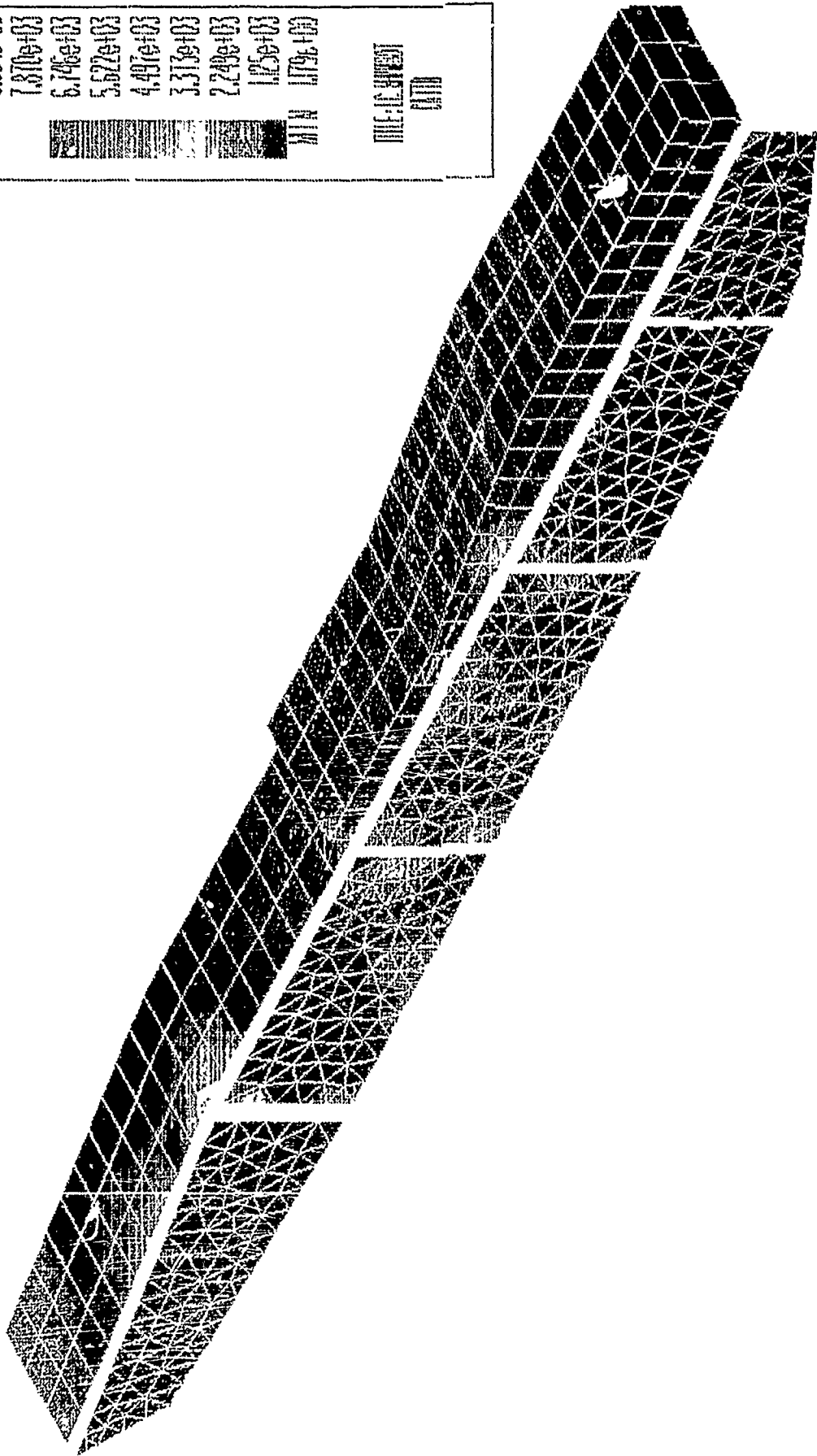

FIG 70 - LEFT SPONSON AND SKIRT FEM MODEL

CATTB STRESS ANALYSIS 1 G LATERAL
 VM STRESS (P.S.I.)



1.399e+04	6.096e+04
1.231e+04	5.245e+04
1.274e+04	4.394e+04
1.012e+04	3.543e+04
8.994e+03	2.692e+04
7.870e+03	1.841e+04
6.746e+03	9.90e+03
5.622e+03	1.04e+03
4.497e+03	1.09e+03
3.373e+03	1.14e+03
2.249e+03	1.19e+03
1.125e+03	1.24e+03
0.001e+03	1.29e+03

FIG 71
 STRESS IN SPONSON AND SKIRT (1 G LATERAL)

CATIB STRESS ANALYSIS : G LATERAL
 LATERAL DISP. (IN)

MAX	3.031e-01
	2.772e-01
	2.623e-01
	2.474e-01
	2.325e-01
	2.176e-01
	2.027e-01
	1.878e-01
	1.729e-01
	1.580e-01
	1.431e-01
	1.282e-01
	1.133e-01
	9.84e-02
	8.35e-02
	6.86e-02
	5.37e-02
	3.88e-02
	2.39e-02
	9.0e-03
MIN	-2.016e-02

FILE:12.HDY
 CATIB

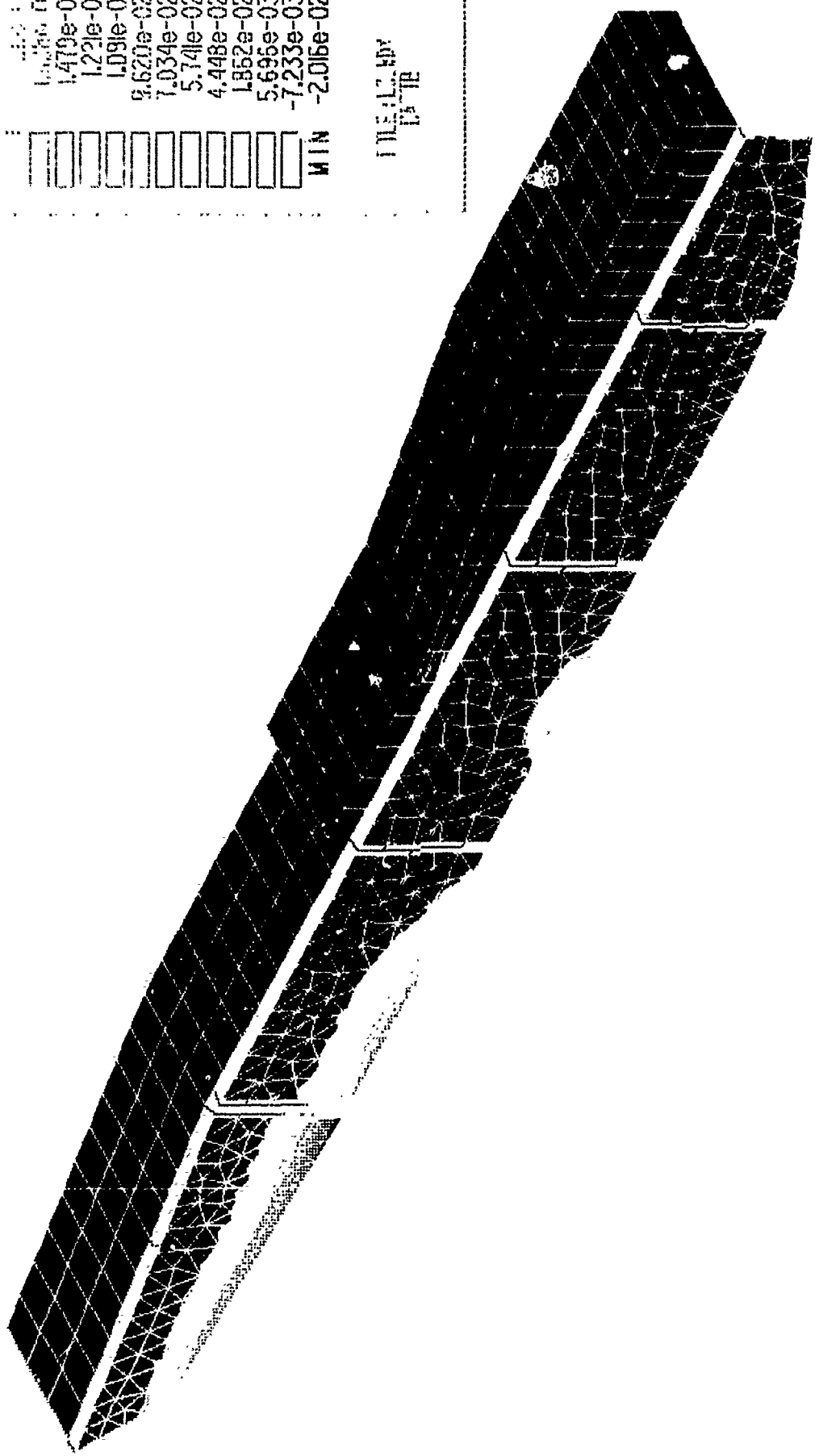
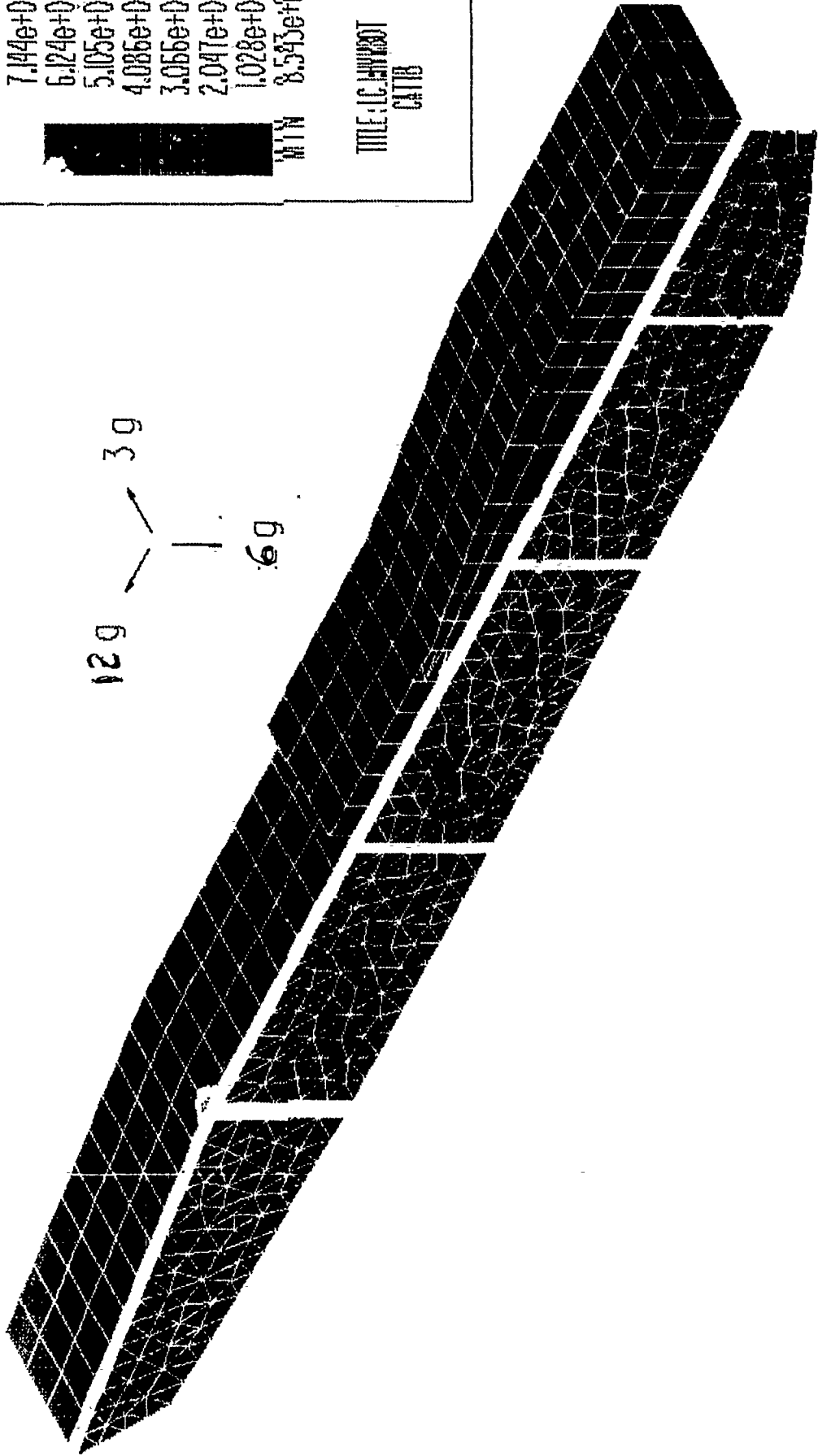

FIG 72
 DEFLECTION IN SPONSON AND SKIRT (1 G LATERAL)

CATTB STRESS ANALYSIS
 VM stress (p.s.i.)



- 1.224e+05
- 1.172e+05
- 1.020e+05
- 9.182e+04
- 8.163e+04
- 7.144e+04
- 6.124e+04
- 5.105e+04
- 4.086e+04
- 3.066e+04
- 2.047e+04
- 1.028e+04
- 8.535e+01

TITLE: IC.HYH2007
 CATTB

12g
 3g
 .6g

FIG 73
 STRESS IN SPONSON AND SKIRT (COMBINED ACCELERATION)

CATTB STRESS ANALYSIS
LATERAL DEF. (IN)

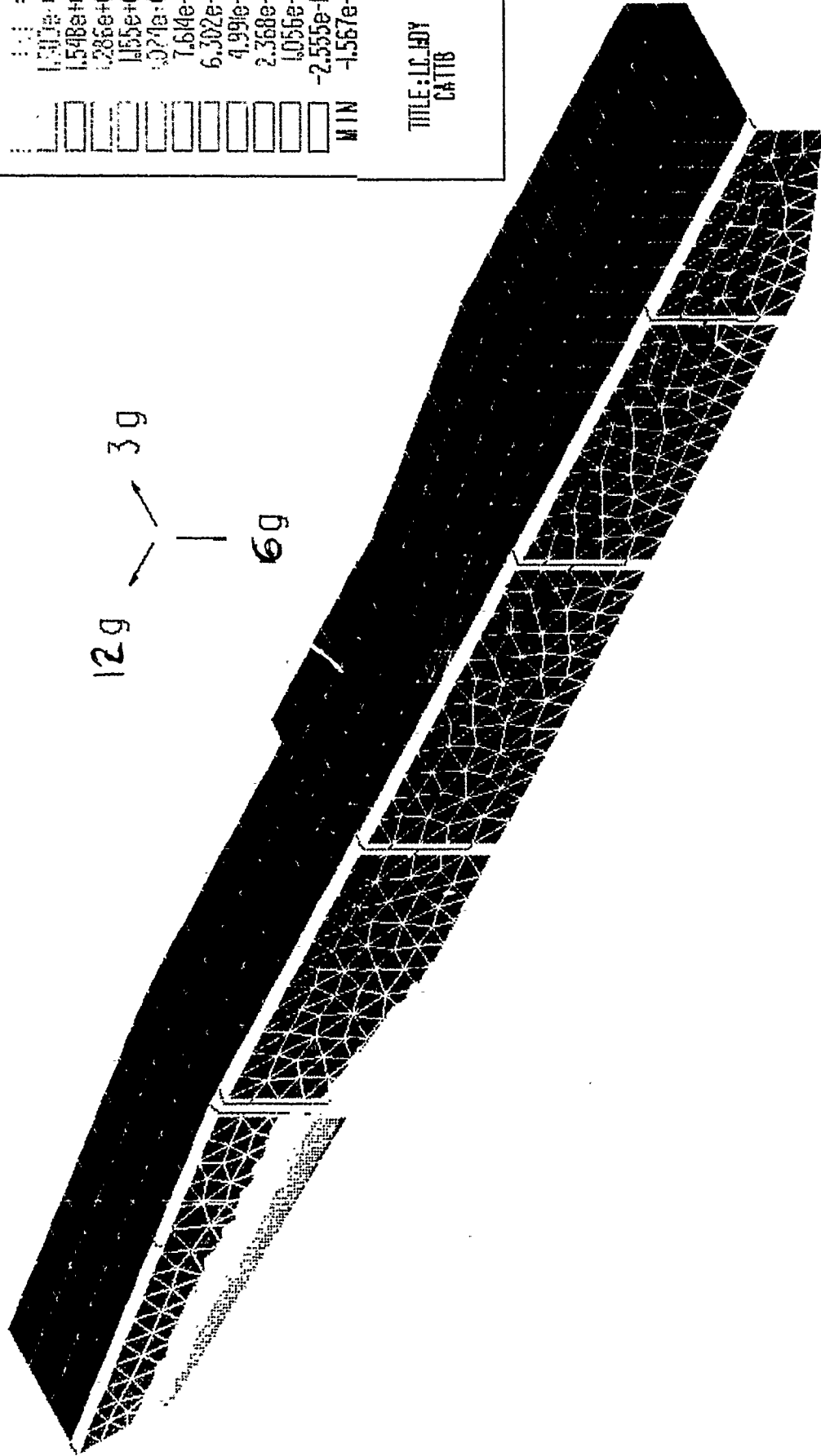
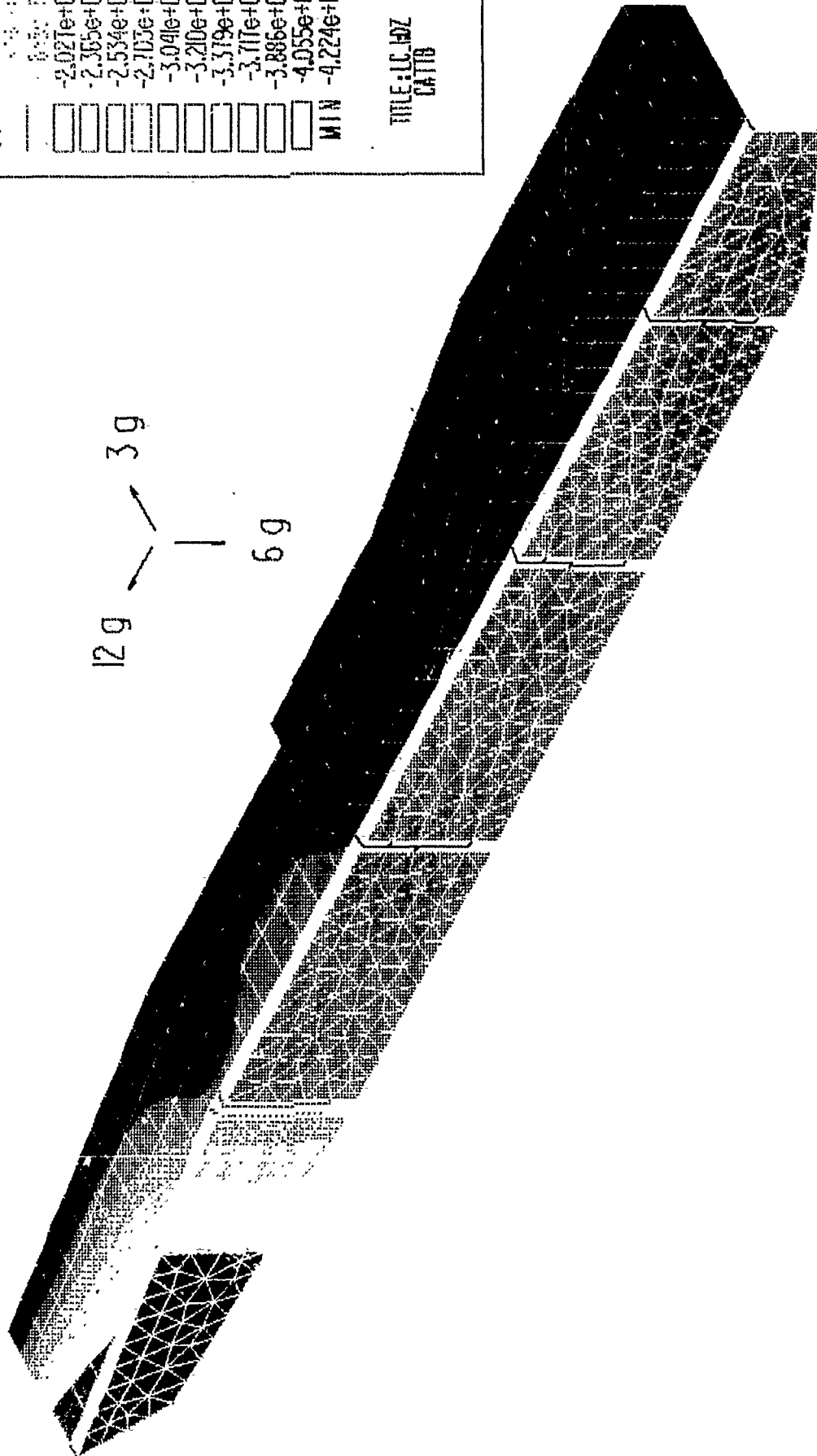

FIG 74
LATERAL DEFLECTION IN SPONSON AND SKIRT (COMBINED ACCELERATION)

CATTB STRESS ANALYSIS
vertical def. (in)



MAX	8.569e-04
	-3.371e-01
	-5.192e-01
	-1.182e+00
	-2.027e+00
	-2.365e+00
	-2.534e+00
	-2.703e+00
	-3.041e+00
	-3.20e+00
	-3.319e+00
	-3.717e+00
	-3.886e+00
	-4.055e+00
MIN	-4.224e+00

TITLE: LC_H0Z
CATTB

FIG 75
VERTICAL DEFLECTION IN SPONSON AND SKIRT (COMBINED ACCELERATION)

CATTB STRESS ANALYSIS
deformed shape

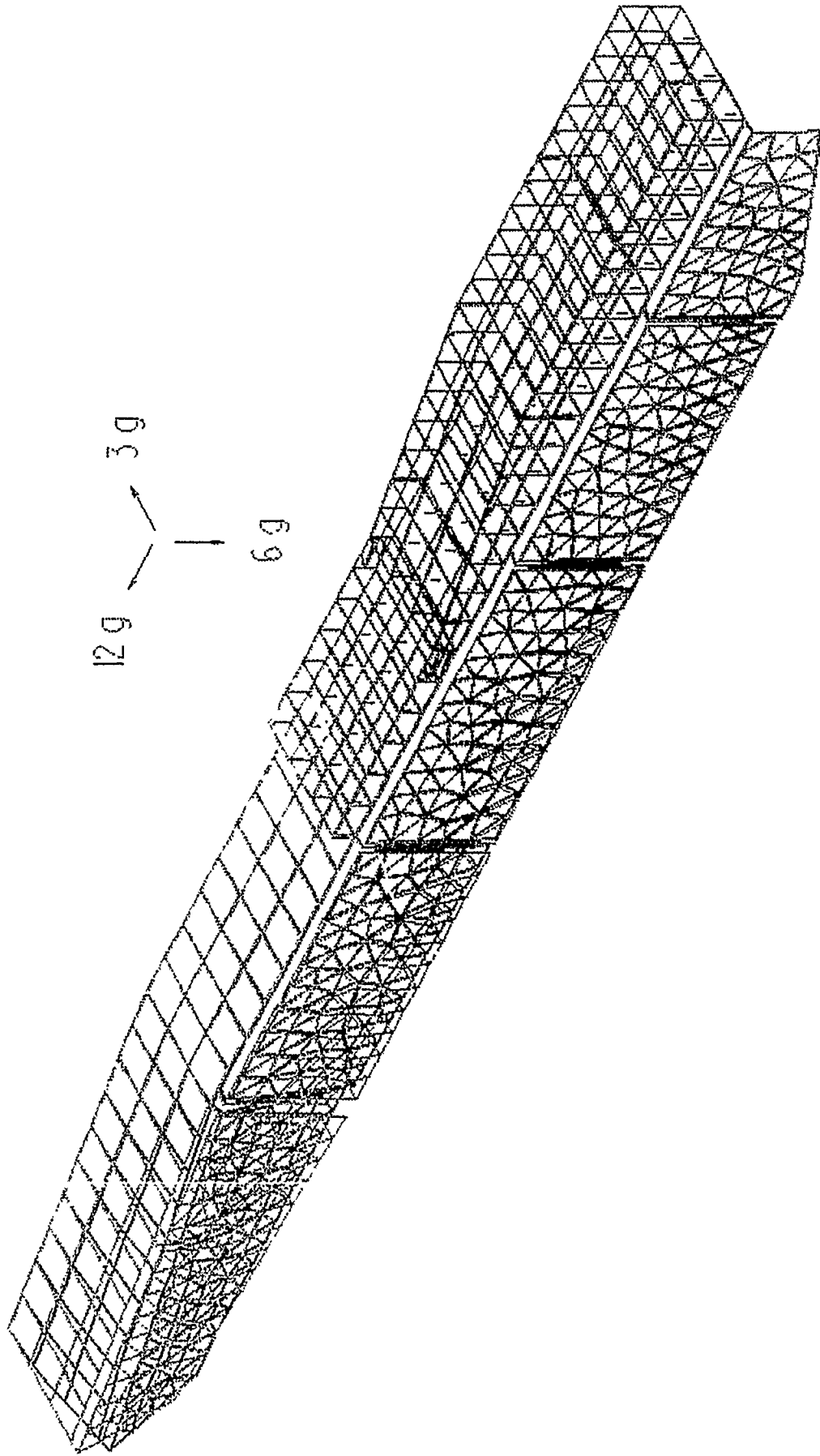

FIG 76
DEFORMED SHAPE FOR SPONSON AND SKIRT (COMBINED ACCELERATION)

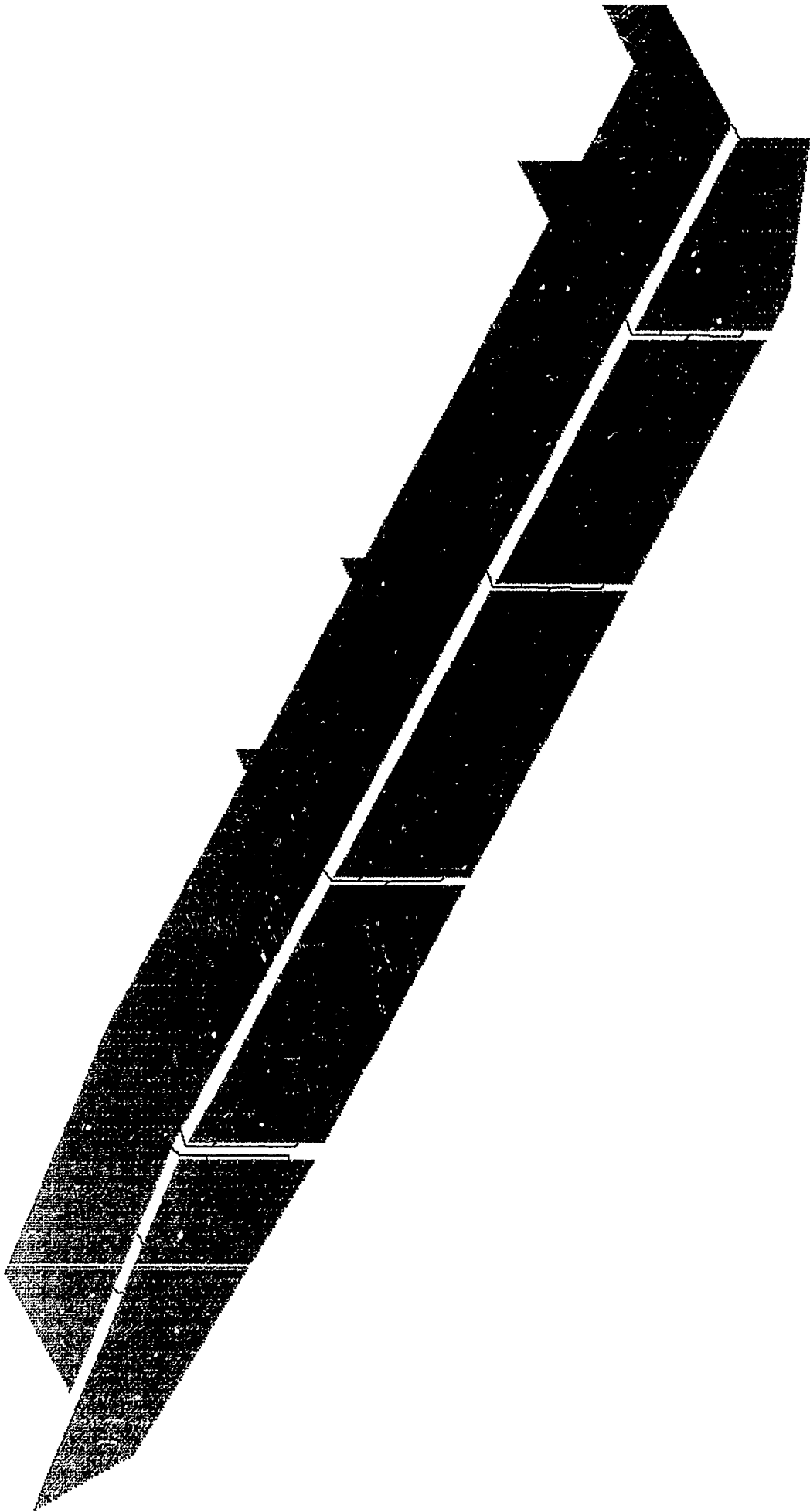

FIG 77
LEFT SPONSON AND SKIRT FEM MODEL
(REINFORCING STRIP ADDED AT PTDCM CENTERLINE)

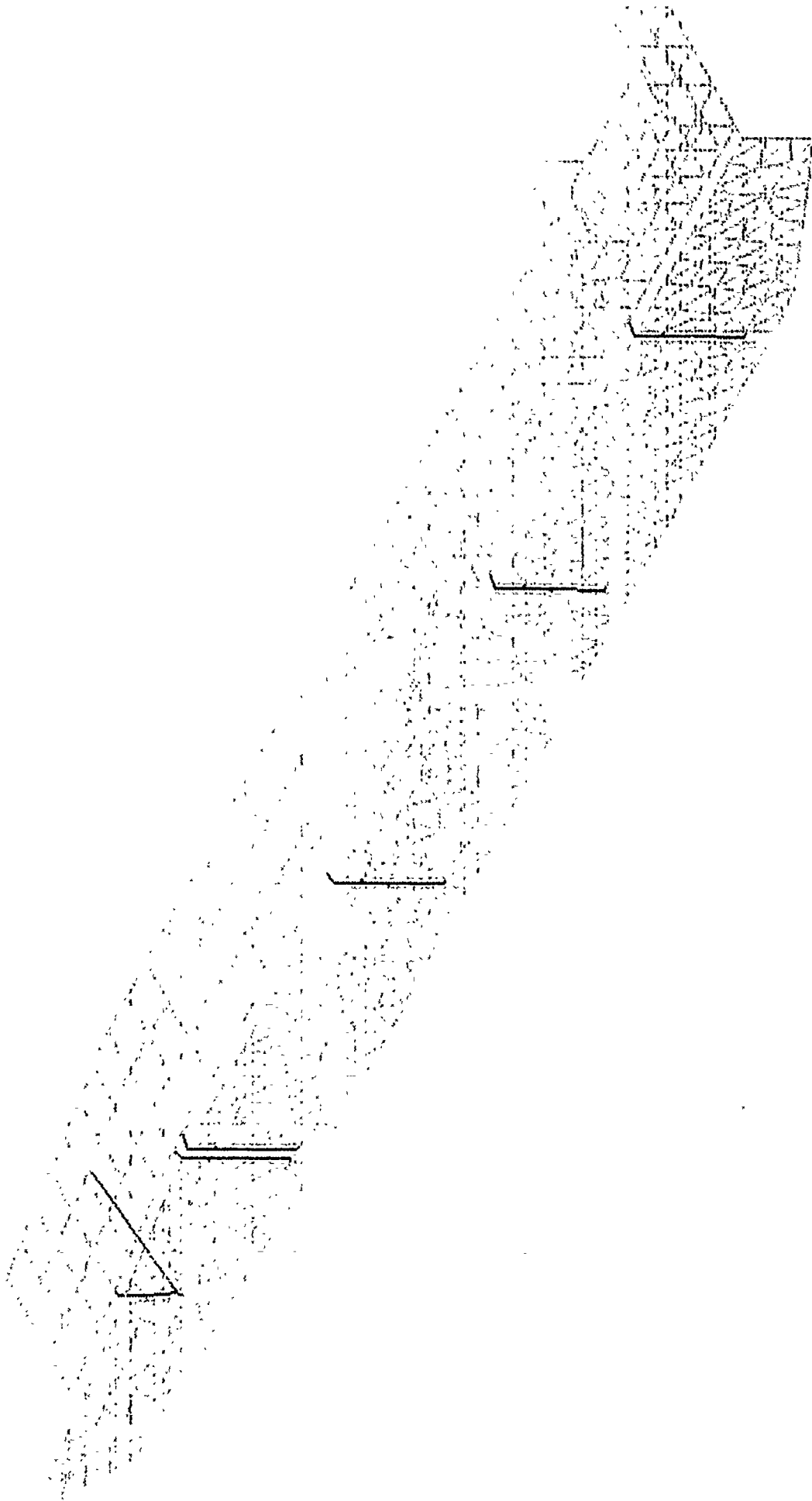

FIG 78
LEFT SPONSON AND SKIRT FEM MODEL
(REINFORCING STRUT ADDED AT FIRST OUTRIGGER)

CATTB STRESS ANALYSIS 1 G LATERAL
 VM STRESS (P.S.I.)

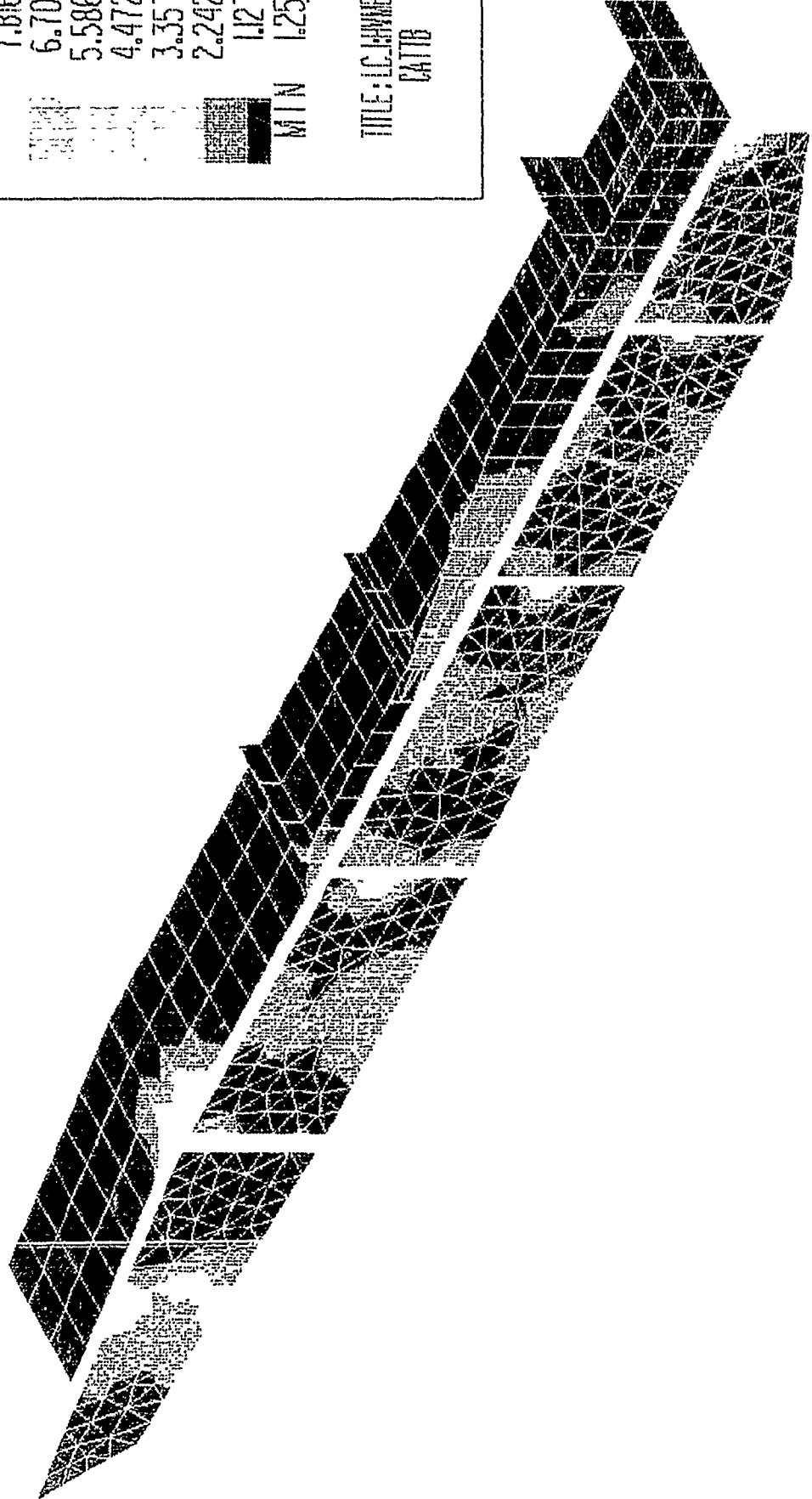
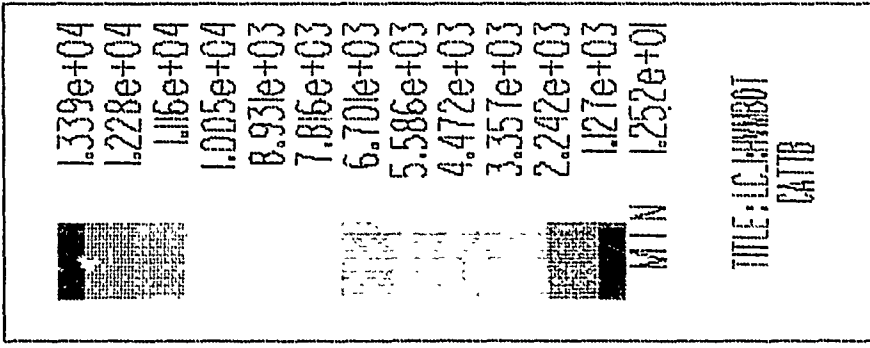

FIG 79
 STRESSES IN REINFORCED SPONSON AND SKIRT (1 G LATERAL)

CATTB STRESS ANALYSIS I G LATERAL
LATERAL DISP. (IN)

MAX	4.892e-01
	4.725e-01
	4.455e-01
	4.185e-01
	3.915e-01
	3.645e-01
	3.375e-01
	3.105e-01
	2.835e-01
	2.565e-01
	2.295e-01
	2.025e-01
	1.755e-01
	1.485e-01
	1.215e-01
	9.45e-02
	6.75e-02
	4.05e-02
	1.35e-02
MIN	-3.775e-02

TITLE: ILLDY
CATTB

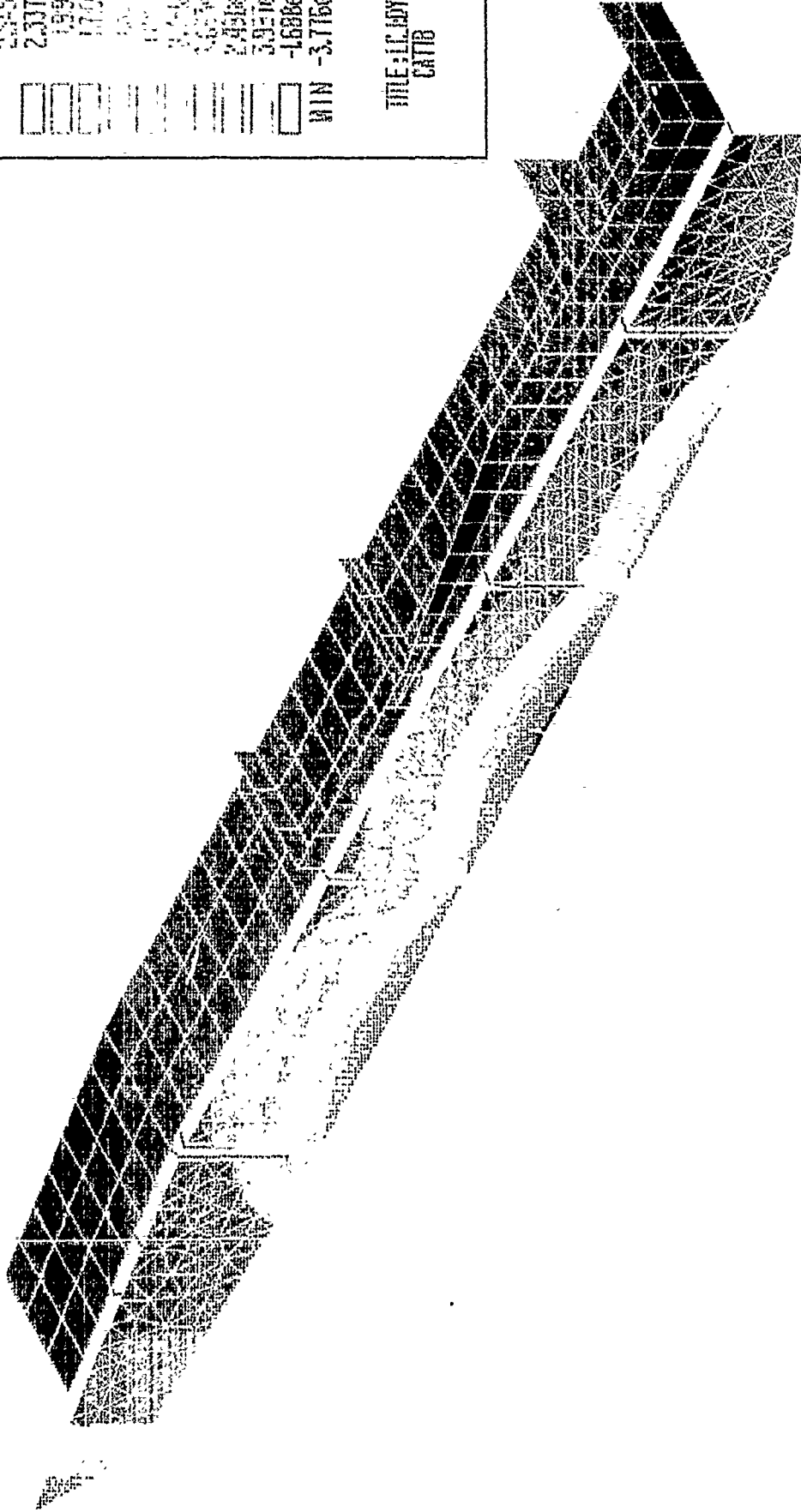
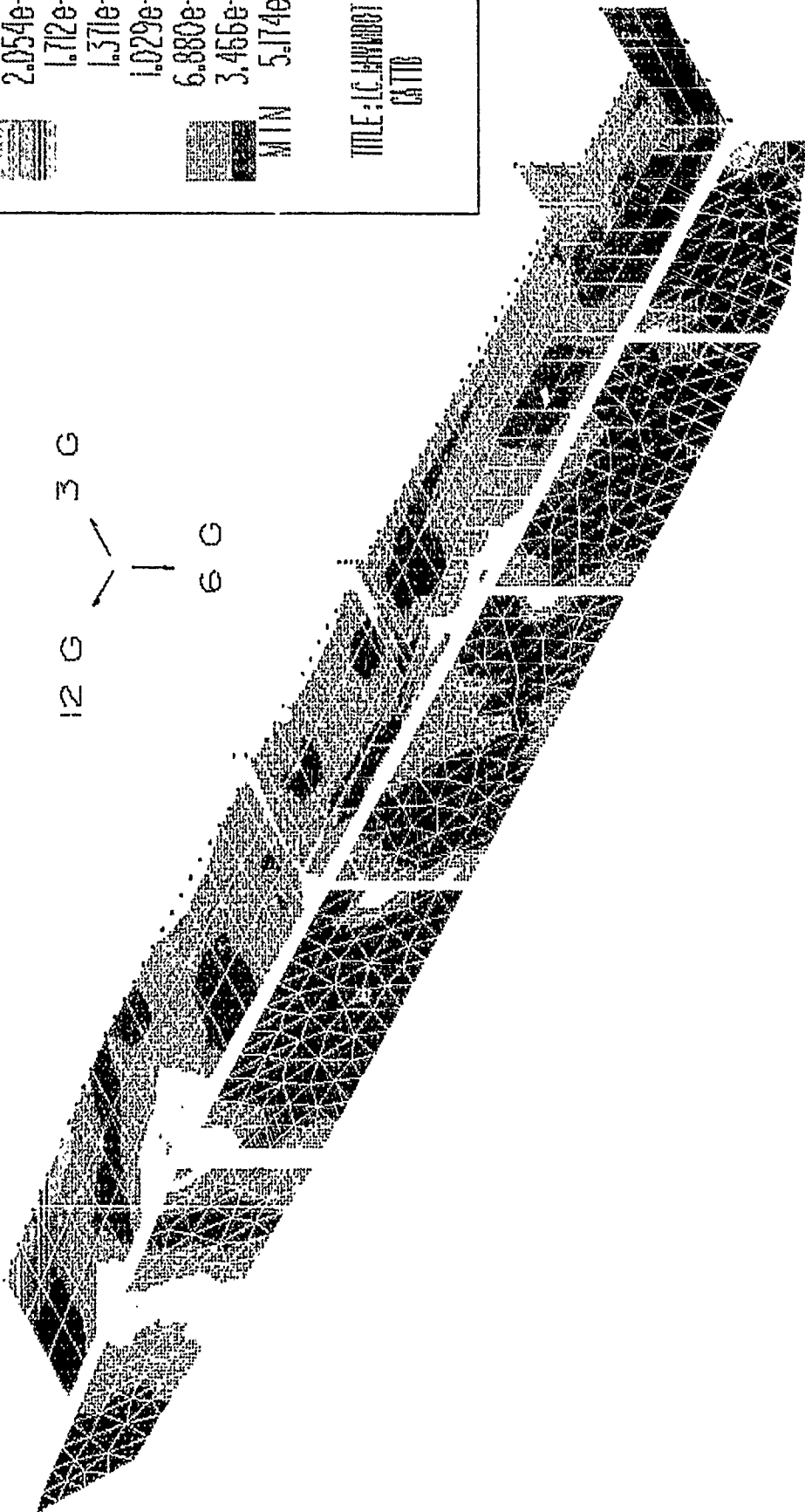

FIG 80
LATERAL DEFLECTION IN REINFORCED SPONSON AND SKIRT (1 G LATERAL)

CATTB STRESS ANALYSIS
 V M STRESS (P-S-I)



12 G 3 G
 6 G

- 4.102e+04
- 3.761e+04
- 3.419e+04
- 3.078e+04
- 2.736e+04
- 2.395e+04
- 2.054e+04
- 1.712e+04
- 1.371e+04
- 1.029e+04
- 6.880e+03
- 3.466e+03
- MIN 5.174e+01

TITLE: LC 8411007
 CATTB

FIG 81
 STRESS IN REINFORCED SPONSON AND SKIRT
 (COMBINED ACCELERATION)

CATTB STRESS ANALYSIS
 VERTICAL DISP. (IN)

MAX	1.103e-03
	-2.970e-02
	-4.511e-02
	-6.051e-02
	-9.152e-02
	-1.067e-01
	-1.221e-01
	-1.529e-01
	-1.683e-01
	-1.837e-01
	-2.145e-01
	-2.299e-01
	-2.453e-01
	-2.762e-01
	-2.916e-01
	-3.070e-01
	-3.378e-01
	-3.532e-01
	-3.686e-01
MIN	-3.840e-01

TITLE: LC:1:0Z
 CATTB

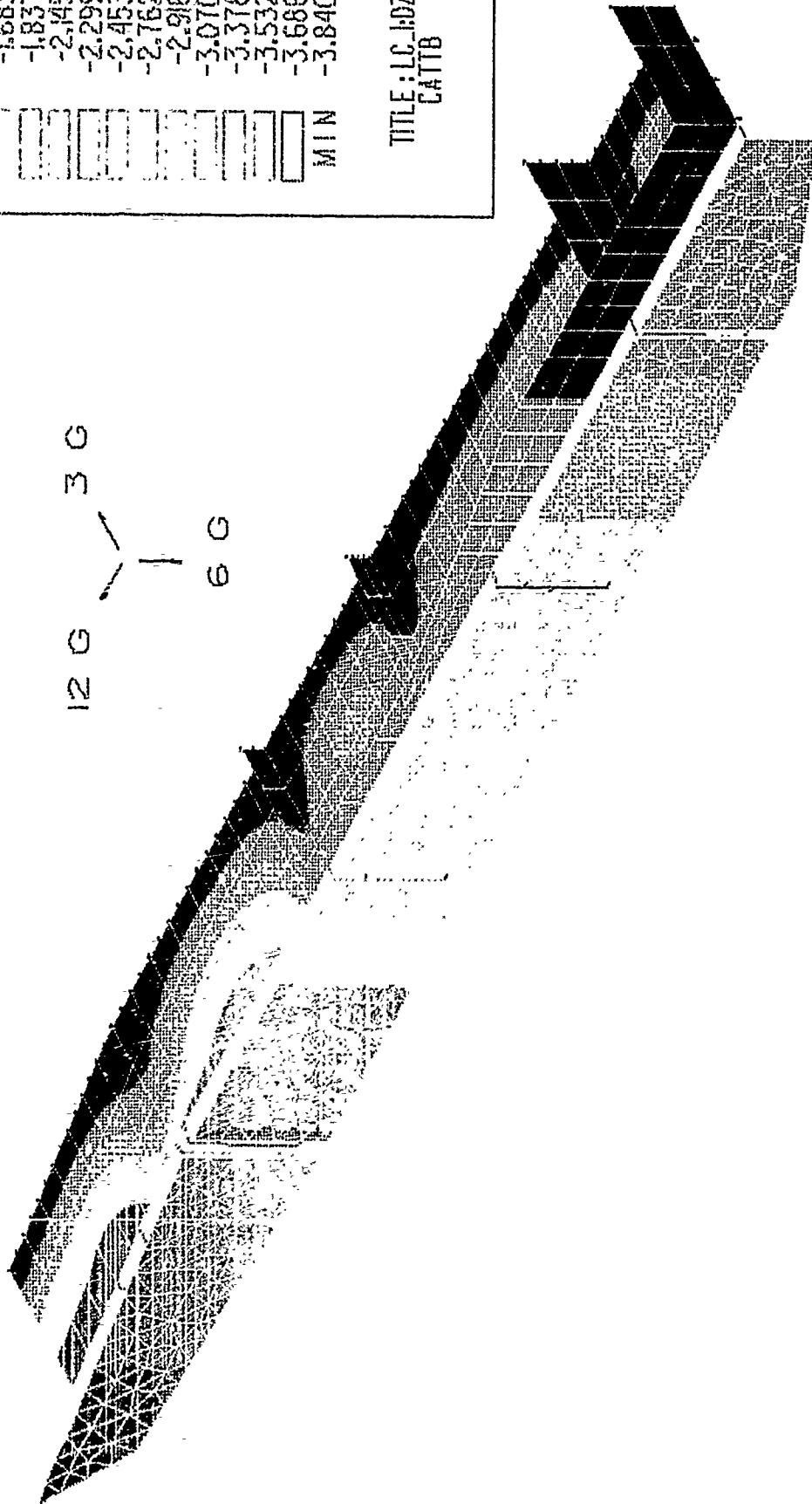
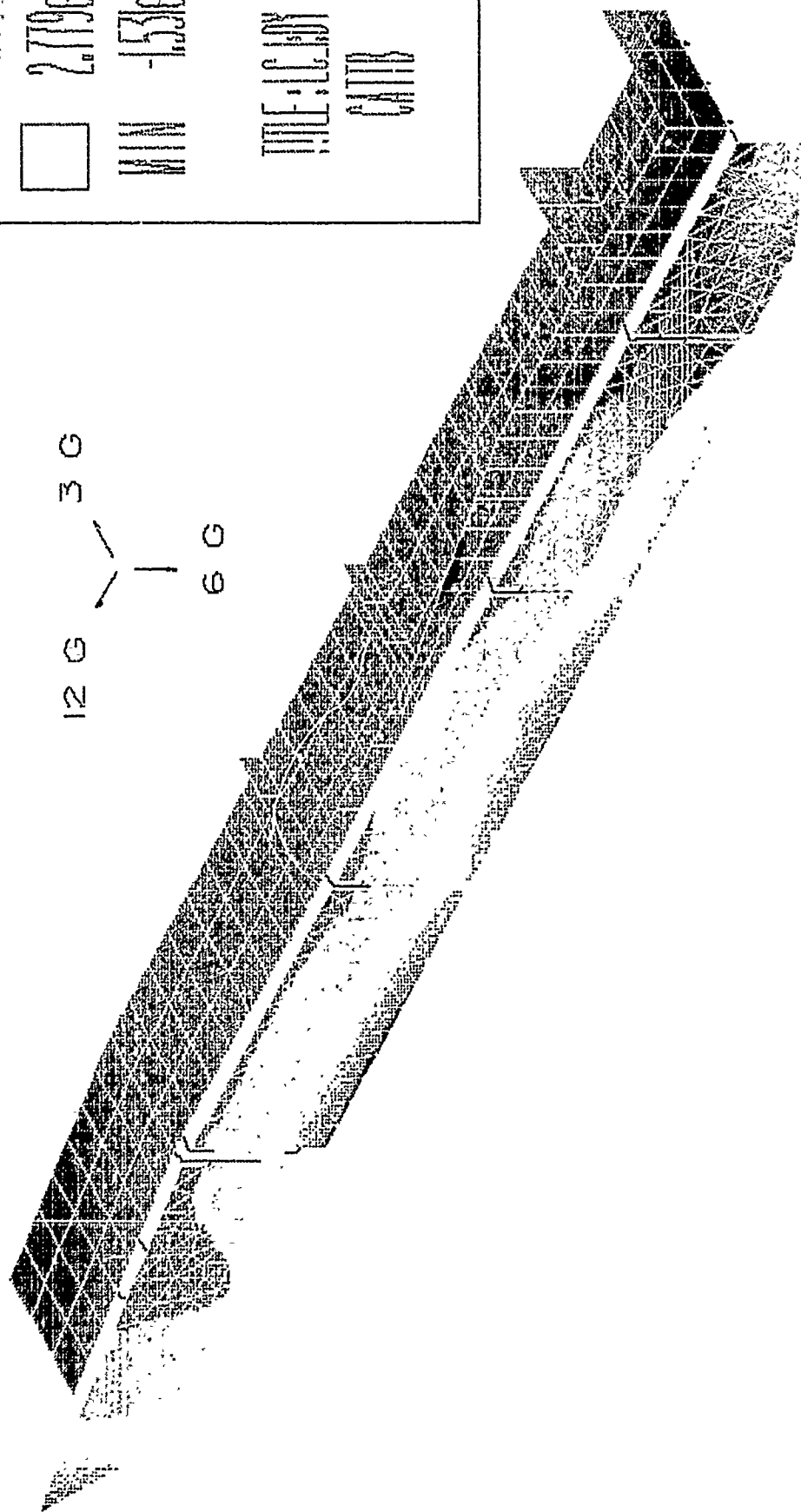

FIG 82
 VERTICAL DEFLECTION IN REINFORCED SPONSON AND SKIRT
 (COMBINED ACCELERATION)

CATTB STRESS ANALYSIS
LATERAL DISP. (IN)



MAX	1.643E+00
	1.140E+00
	7.099E-01
	2.779E-01
MIN	-1.539E-01
TITLE: LC 104	
CATTB	

FIG 83
LATERAL DEFLECTION IN REINFORCED SPONSON AND SKIRT
(COMBINED ACCELERATION)

CATTB STRESS ANALYSIS
DEFORMED SHAPE

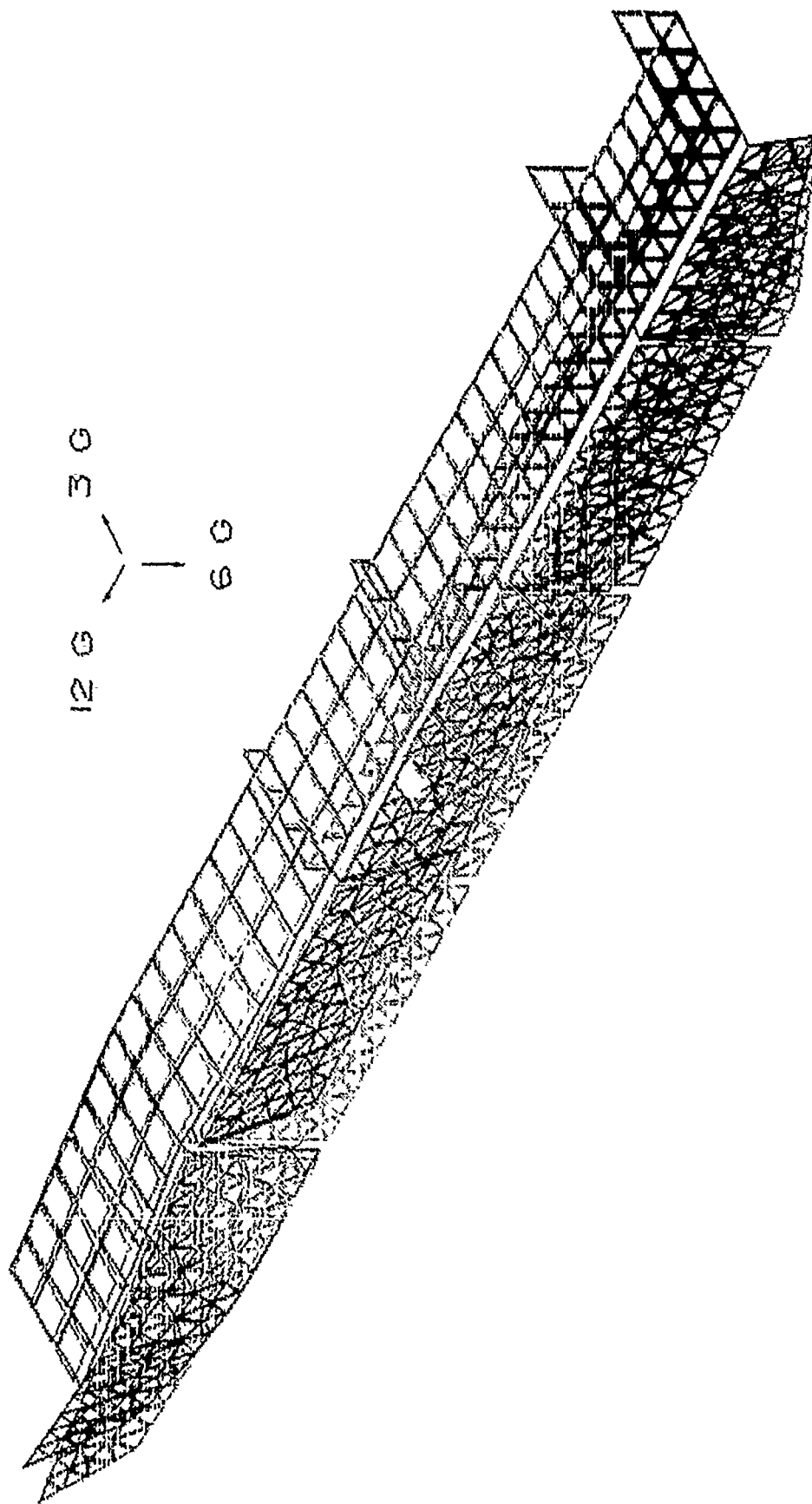

FIG 84
DEFORMED SHAPE FOR REINFORCED SPONSON AND SKIRT
(COMBINED ACCELERATION)

Element Post Data

Results set : RS1

Elem No.	LC_1:VY1	LC_1:VZ1	LC_1:TX1	LC_1:MY1	LC_1:MZ1	LC_1:AX1
1	6.6144e+02	-8.8331e+02	-1.9690e+02	-3.3157e+01	-4.5050e+02	1.3766e+02
2	6.6040e+02	-8.0150e+02	-1.9690e+02	-6.6823e+02	-9.7341e+02	1.3651e+02
3	6.5936e+02	-7.9969e+02	-1.9690e+02	-1.3019e+03	-1.4955e+03	1.3536e+02
4	6.5832e+02	-7.9788e+02	-1.9690e+02	-1.9341e+03	-2.0168e+03	1.3421e+02
5	4.2169e+02	1.5073e+03	1.2572e+03	-4.5852e+03	-3.9413e+03	-8.3283e+02
6	4.2254e+02	1.5107e+03	1.2572e+03	-2.6349e+03	-4.4869e+03	-8.3453e+02
7	4.2339e+02	1.5141e+03	1.2572e+03	-6.8017e+02	-5.0337e+03	-8.3623e+02
8	4.2424e+02	1.5175e+03	1.2572e+03	1.2789e+03	-5.5815e+03	-8.3794e+02
13	7.9565e+02	-2.0048e+03	-8.1143e-05	5.7694e+03	3.4849e+03	7.2408e+01
14	7.9466e+02	-2.0028e+03	-8.1143e-05	4.2658e+03	2.8881e+03	7.1915e+01
15	7.9367e+02	-2.0009e+03	-8.1143e-05	2.7637e+03	2.2921e+03	7.1421e+01
16	7.9269e+02	-1.9989e+03	-8.1143e-05	1.2631e+03	1.6969e+03	7.0928e+01
17	2.0939e+03	5.3952e+01	3.3024e+01	8.4023e+02	1.3244e-03	7.4929e+02
18	2.0936e+03	5.3642e+01	3.3024e+01	8.6564e+02	-9.8614e+02	7.4795e+02
19	2.5327e+03	8.6017e+01	-3.7097e+02	-1.8071e+03	2.5955e+03	-1.6423e+03
20	2.5324e+03	8.6354e+01	-3.7100e+02	-1.7630e+03	1.2977e+03	-1.6408e+03
21	-2.1812e+03	5.2593e+01	8.6024e+01	6.8114e+02	3.4876e-04	-7.3569e+02
22	-2.1821e+03	5.2953e+01	8.6024e+01	7.0993e+02	1.1937e+03	-7.3440e+02
23	1.8285e+03	1.7262e+02	-1.5491e+02	1.9842e+03	-7.2672e-04	1.5920e+03
24	1.8275e+03	1.7296e+02	-1.5488e+02	2.0727e+03	-9.3695e+02	1.5932e+03
25	3.4409e+03	6.4950e+01	-2.4129e+01	-8.7344e+02	3.4405e+03	-5.5525e+02
26	3.4402e+03	6.4621e+01	-2.4129e+01	-8.4096e+02	1.7201e+03	-5.5656e+02

FIG 85 FORCES IN OUTRIGGERS AND STRUT

4.3 Dynamic Analysis

The desire to determine the CATTB geometric and operating characteristics, such as gun, breach displacement, velocity and acceleration, chassis roll and pitch angle and suspension effects on the CATTB chassis due to terrain and firing loads, all necessitate conducting a dynamic analysis for the CATTB. This was accomplished by building a dynamic model and analyzing it, using the DADS program on the Cray supercomputer. This study supplements a concurrent simulation, study prepared by another TACOM directorate, since it mainly deals with the effect of the various dynamic forces on the CATTB Chassis.

4.3.1 DADS Model

To create a DADS model, the geometry of the CATTB chassis had to be established. Road arms, idler and sprocket positions must be established with regard to Chassis CG. This is shown in Figures (86 - 88). The mass properties are established from CATTB solid models (section 3.2) and summarized in Table 5. The DADS model consists of 17 rigid bodies, guns, turret, hull and 14 road wheels. These bodies are connected by 16 joints, trunnion, ring, and 14 roadwheel attachment points, as shown in Fig (89). The track and suspension and terrain characteristics are imposed on this model, as shown in Fig (90). Suspension stiffness and damping curves utilized where those of Teledyne 3870 ESS Series as shown in Fig (91 & 92).

These two curves are transformed into torque versus angular displacement and torque versus angular velocity by using the following formulas:

$$T = FR \cos \theta$$
$$A = R \sin \theta$$

WHERE:

T : Torque (lb - in)
R : Road Arm Length (17 inches)
F : Force (lbs)
A : Wheel Travel (inches)
θ : Road Arm Angle From horizontal position.

The resulting curves are shown in Fig (93 & 94). The impulse curve for the lightweight gun used is shown in Fig (95). The terrain used was APG 4 whose profile is shown in Fig (96). A more drastic custom-made profile with a series of bumps and holes (spaced to maximize terrain effects on the Chassis), can be used in Fig (97). The CATTB DADS model was driven at a constant speed (30 mph), and the acceleration and forces at various location were calculated. It is worthwhile to mention that the hydroneumatic suspension model runs on DADS were not successful. In lieu of waiting for the DADS code to be fixed, an M1 suspension was used on the CATTB DADS model. In the future, when the DADS code is fixed, a follow-up study can be performed with minimum efforts. A detailed input file for the DADS model is attached in Appendix D.

4.3.2. DADS Results

A DADS model was analyzed under two separate load cases so that they could be combined at any time step and with any proportion desired. The first load case is ABG4 terrain effects on the CATTB. This can be presented in the form of time-dependent curves for the following parameters:

4.3.3 Terrain Effects

Pitch and Roll Angles	Fig 98
Vertical Acceleration of Chassis at C.G	Fig 99
Vertical Acceleration of First Road	Fig 99
Vertical Forces in Road Wheels 1,4 and 7	Fig 100
Vertical Forces in Road Wheels 2,3,5 and 6	Fig 101
Maximum Vertical Chassis Acceleration	Fig 102
Maximum Chassis Angular Acceleration	Fig 103

Maximum Vertical Forces in roadwheels (Case 1):

L1, L4 and L7	Fig 104
L2, L3, L5 and L6	Fig 105
R1, R7 and R7	Fig 106
R2, R3, R5 and R6	Fig 107

Maximum Vertical Forces in roadwheels (Case 2):

L1, L4 and L7	Fig 108
L2, L3, L5 and L6	Fig 109
R1, R4 and R7	Fig 110
R2, R3, R5 and R6	Fig 111

Case (1) assumed maximum bending to occur under first roadwheel and it occurred at 23.8 seconds. Case (2) assumed maximum bending to be under the forth roadwheel and it occurred at 30.5 seconds. In reality, there are many cases for the bending of the chassis which falls between these two load cases, and their effects must be considered. However, the complexity of the process leads to this simplification. This will be discussed later when addressing the bending stresses in the dynamic finite element analysis.

4.3.4 Firing Load Effects

Fore AFT Gun Breach Displacement	Fig 112
Fore AFT Gun Pitch Angle Displacement	Fig 113
Fore AFT Gun Velocity	Fig 114
Fore AFT Gun Acceleration	Fig 115
Chassis Longitudinal Acceleration	Fig 116
Chassis Vertical Acceleration	Fig 116
Maximum Vertical Forces in Road Wheels:	
L1 to L7	Fig 117
L1, L4 and L7	Fig 118
L2, L3, L5 and L6	Fig 119

Results of the previous DAD analyses are attached for comparison Fig (120 - 122).

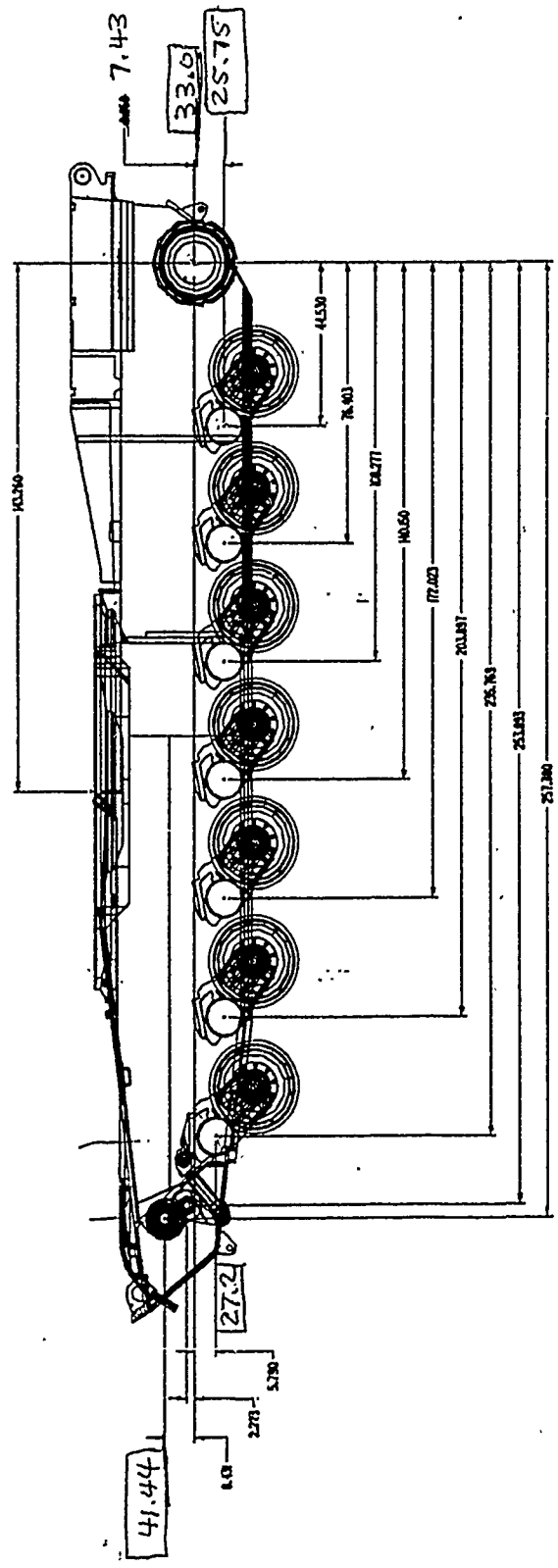
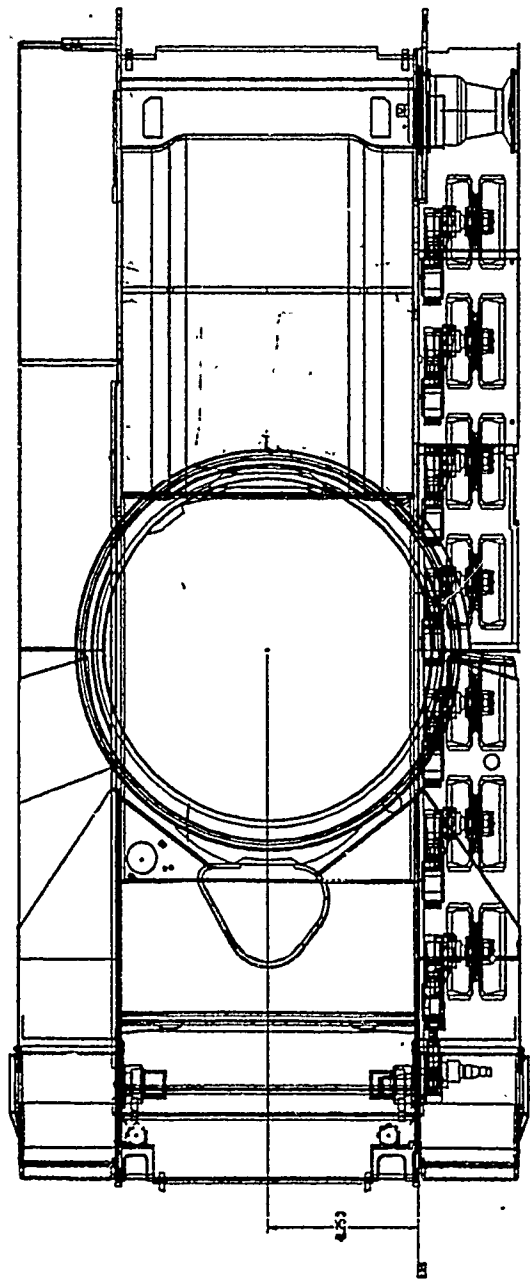

PART NO. DTAT74518.TMP	
U.S. ARMY TANK CENTER, TAMPA, FLORIDA 33610-5000	
DATE	1975
BY	EEES
CHKD	
APPROVED	
PRELIMINARY SUSPENSION	
K 19207 DTAT74518.TMP	
REV. 1	
REV. 2	
REV. 3	
REV. 4	
REV. 5	
REV. 6	
REV. 7	
REV. 8	
REV. 9	
REV. 10	
REV. 11	
REV. 12	
REV. 13	
REV. 14	
REV. 15	
REV. 16	
REV. 17	
REV. 18	
REV. 19	
REV. 20	
REV. 21	
REV. 22	
REV. 23	
REV. 24	
REV. 25	
REV. 26	
REV. 27	
REV. 28	
REV. 29	
REV. 30	
REV. 31	
REV. 32	
REV. 33	
REV. 34	
REV. 35	
REV. 36	
REV. 37	
REV. 38	
REV. 39	
REV. 40	
REV. 41	
REV. 42	
REV. 43	
REV. 44	
REV. 45	
REV. 46	
REV. 47	
REV. 48	
REV. 49	
REV. 50	
REV. 51	
REV. 52	
REV. 53	
REV. 54	
REV. 55	
REV. 56	
REV. 57	
REV. 58	
REV. 59	
REV. 60	
REV. 61	
REV. 62	
REV. 63	
REV. 64	
REV. 65	
REV. 66	
REV. 67	
REV. 68	
REV. 69	
REV. 70	
REV. 71	
REV. 72	
REV. 73	
REV. 74	
REV. 75	
REV. 76	
REV. 77	
REV. 78	
REV. 79	
REV. 80	
REV. 81	
REV. 82	
REV. 83	
REV. 84	
REV. 85	
REV. 86	
REV. 87	
REV. 88	
REV. 89	
REV. 90	
REV. 91	
REV. 92	
REV. 93	
REV. 94	
REV. 95	
REV. 96	
REV. 97	
REV. 98	
REV. 99	
REV. 100	

FIG. 86
 CATTB GEOMETRY
 ROADWHEELS POSITIONS RELATIVE TO SPOCKET

RDE CENT R - TACOM



CATTB ROAD ARM LENGTH = 17 INCHES
 MIAI ROAD ARM LENGTH = 20 INCHES

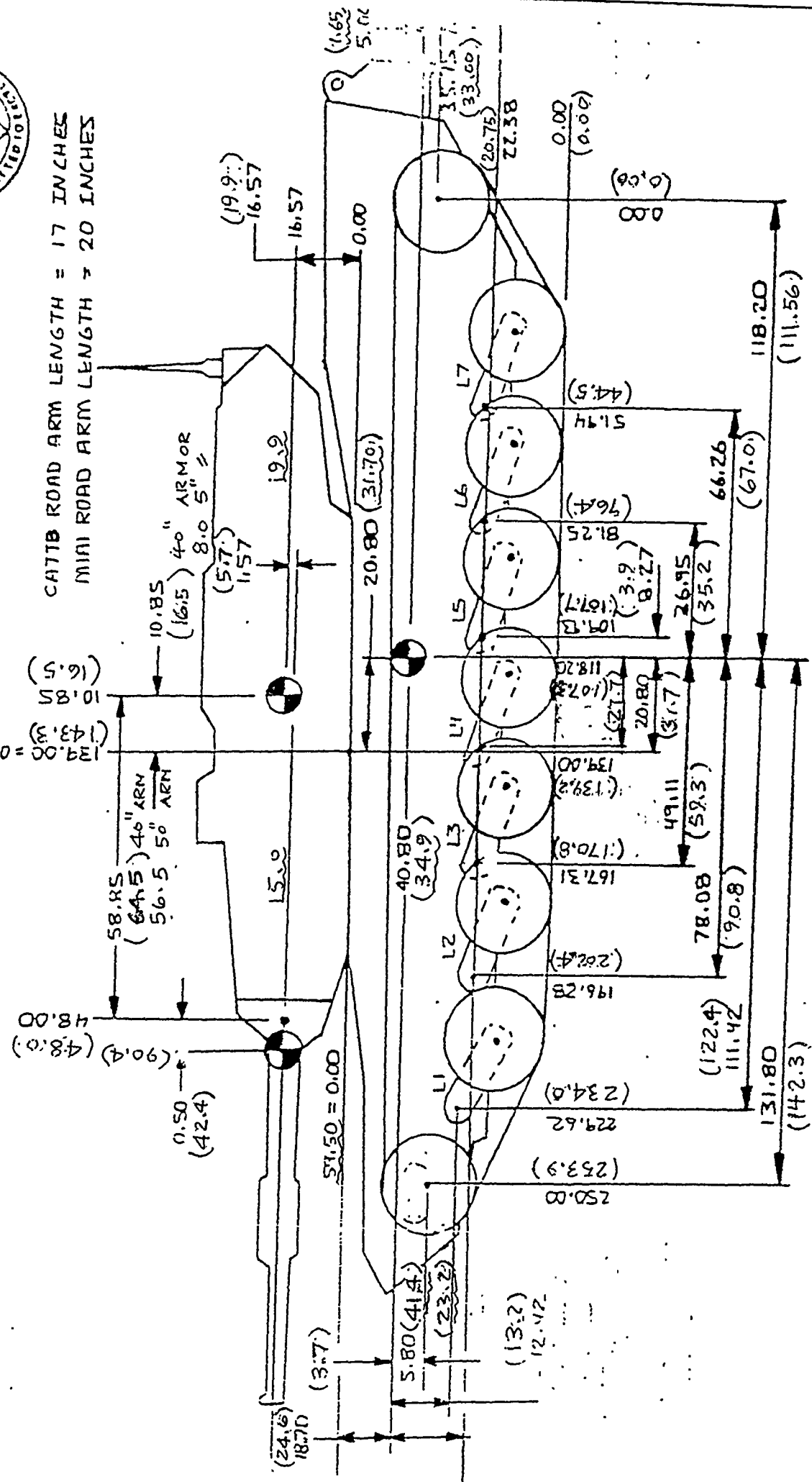

(CATTB DIMENSIONS IN PARENTHESSES)
 MIAI DIMENSIONS AS SHOWN
 FIG 87

CATTB GEOMETRY - ROADWHEELS POSITIONS RELATIVE TO C.G.



RDE CENT & TACOM

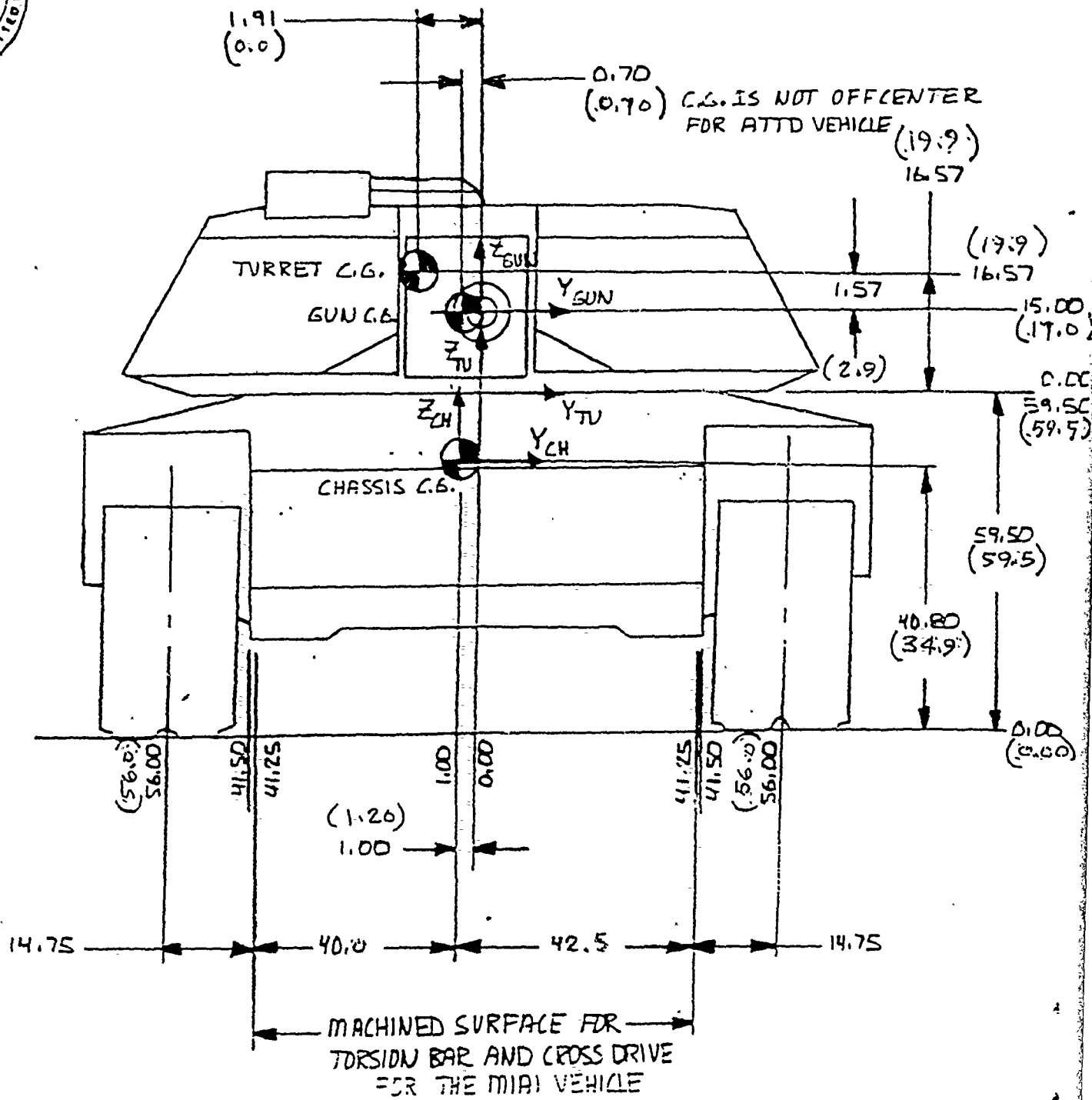

(SOME DIMENSIONS IN PARENTHESES)
MIAI DIMENSIONS AS SHOWN

FIG 88
CATTB GEOMETRY
ROADWHEELS POSITIONS RELATIVE TO C.G



U.S. ARMY
TANK
AUTOMOTIVE COMMAND

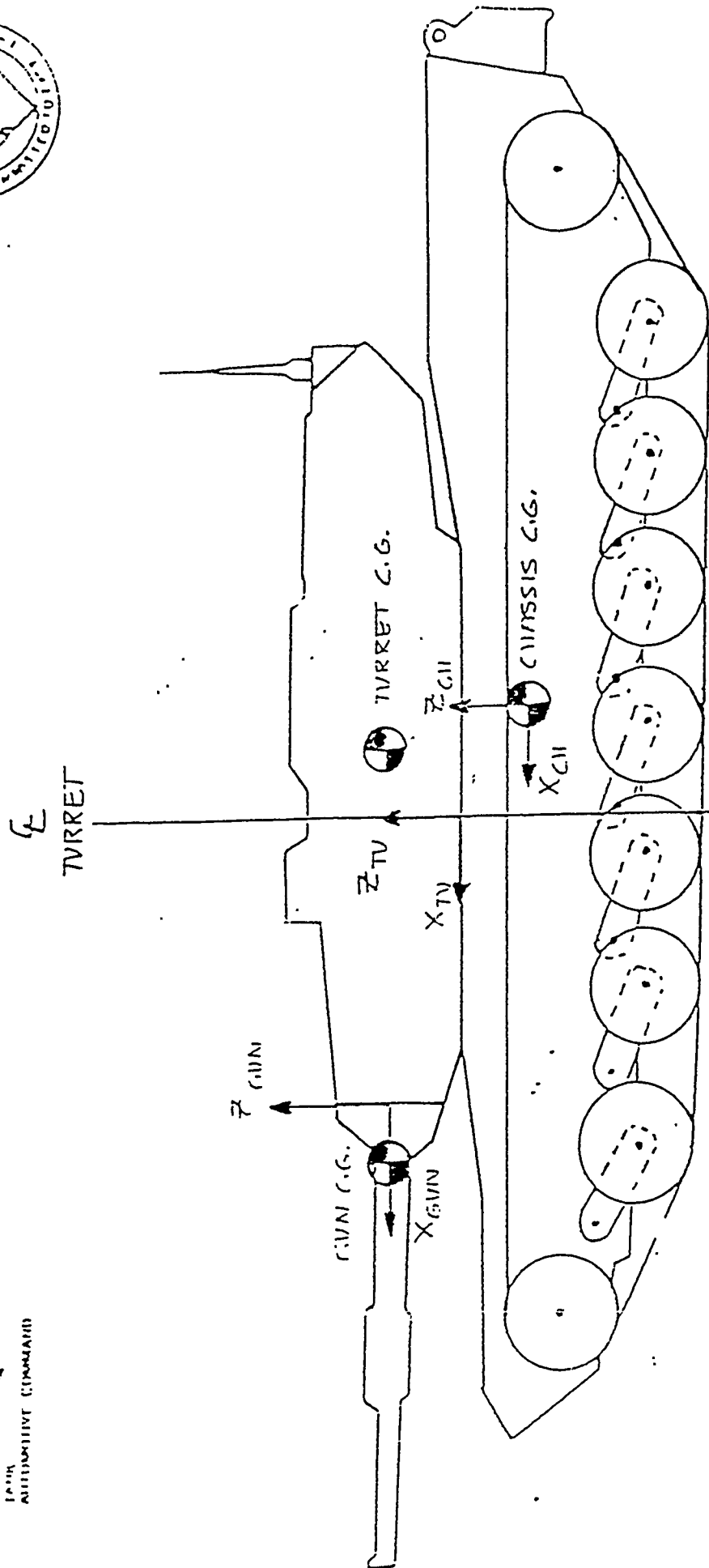

CATTB VEHICLE			MIII VEHICLE		
WEIGHT	INERTIA ABOUT C.G.		WEIGHT	INERTIA ABOUT C.G.	
	I _{xx}	I _{yy}		I _{xx}	I _{yy}
69,100	256,030	1,617,750	71,174	162,1344	1853,160
42,600	163,676	348,728	37,535	231,528	314,666
103,100	1,270	154,450	4252	2,340	39048
121,800			118,181		

CHASSIS, TURRET MASS CENTER LOCATED
TURRET AND MAIN X COG X COG (IN INCH)
MAIN GUN WITH COG
TURRET TURRET MASS WEIGHT

TABLE 5 - CATTB GEOMETRY MASS PROPERTIES

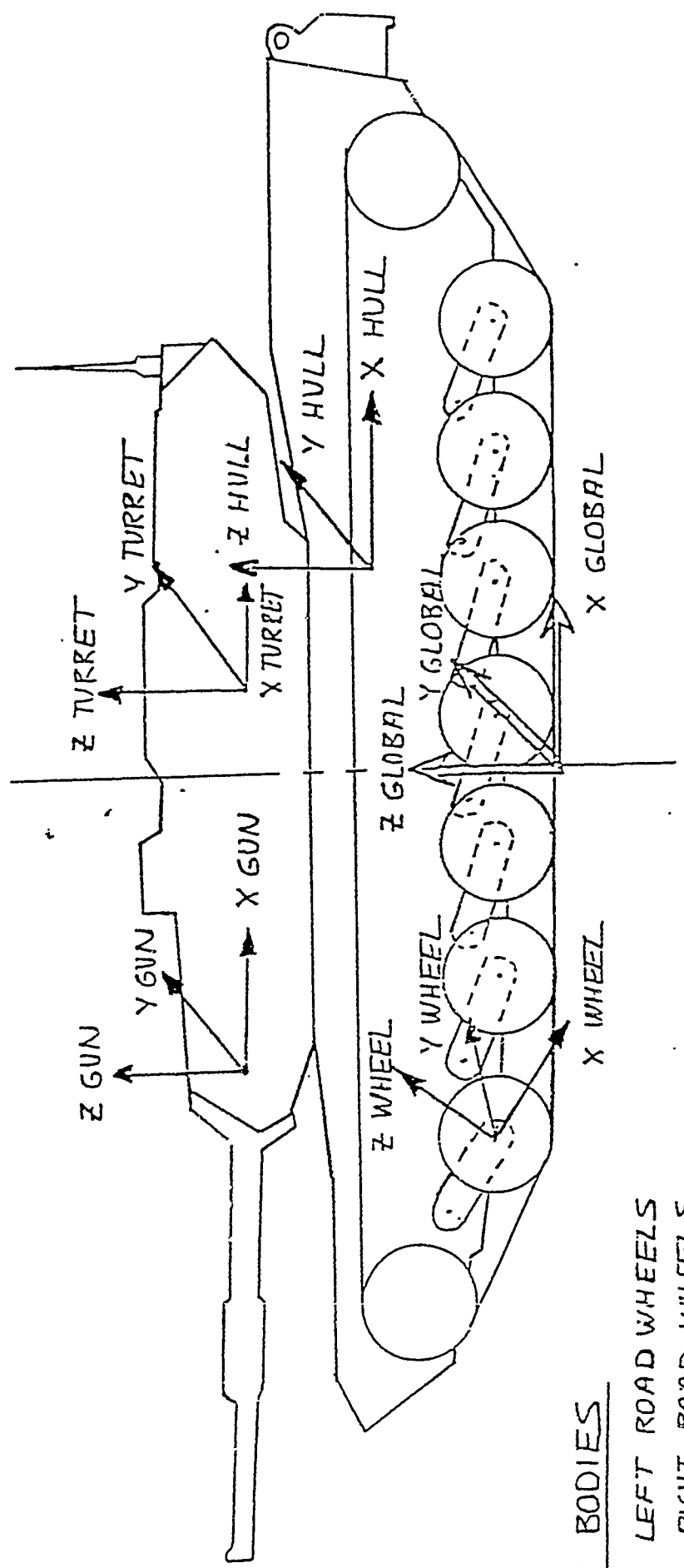

17 BODIES

7 LEFT ROAD WHEELS

14 RIGHT ROAD WHEELS

5 HVLL.

6 TURRET

7 GUN

FIG 89
CATFB GEOMETRY - SUSPENSION



RDE CENTER - TACOM

U.S. ARMY
TAMC -
AUTOMOTIVE COMMAND

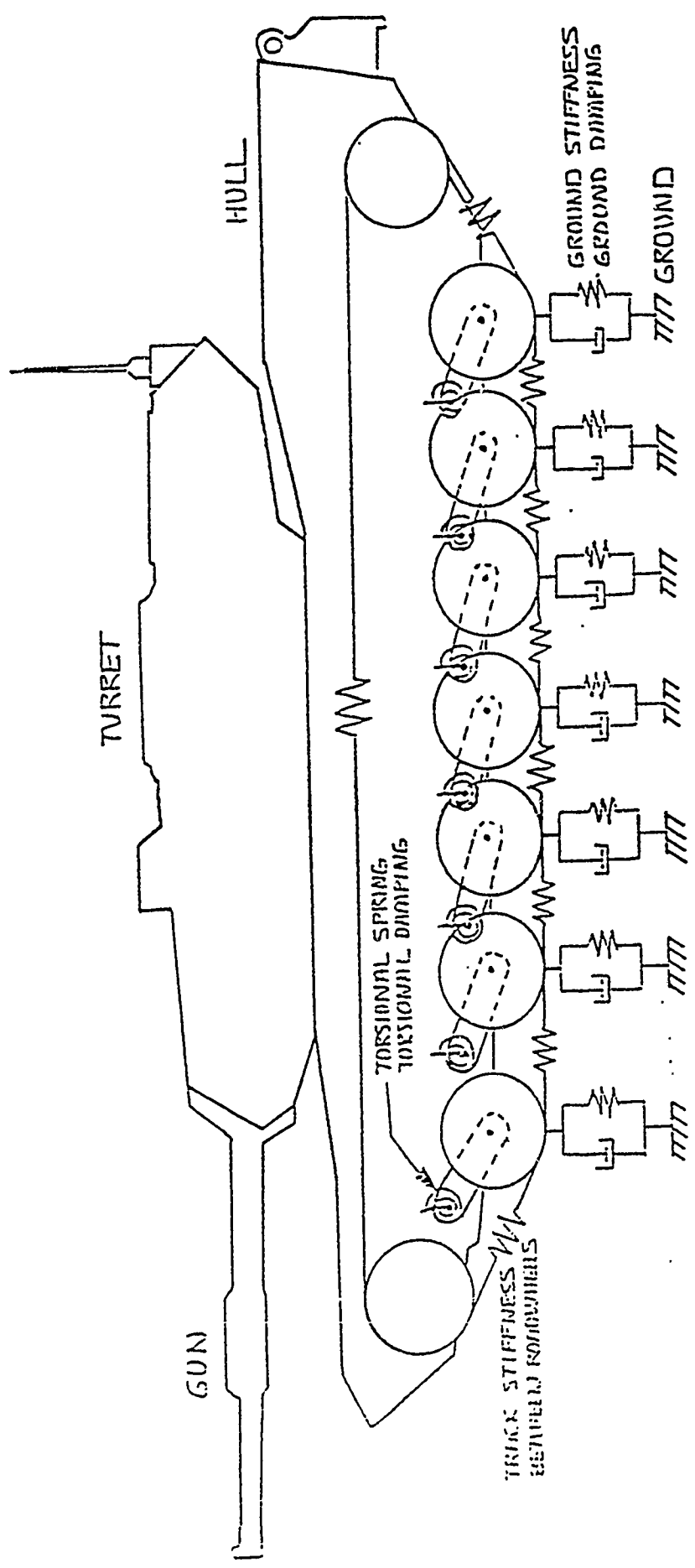
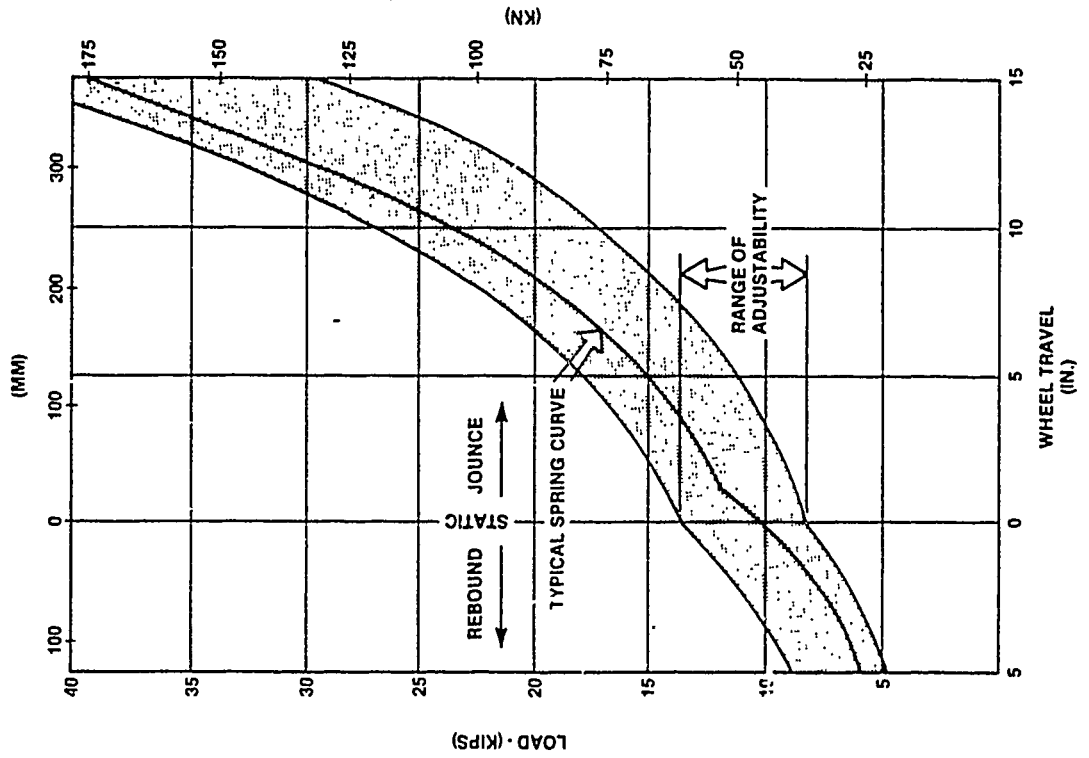

FIG 90
CATB GEOMETRY - TRACK AND SUSPENSION

CATTB/3870 ESS Spring Response

6316



(FIG. 91) CATTB GEOMETRY - SUSPENSION STIFFNESS CURVE

CATTB/3870 ESS Damping Response

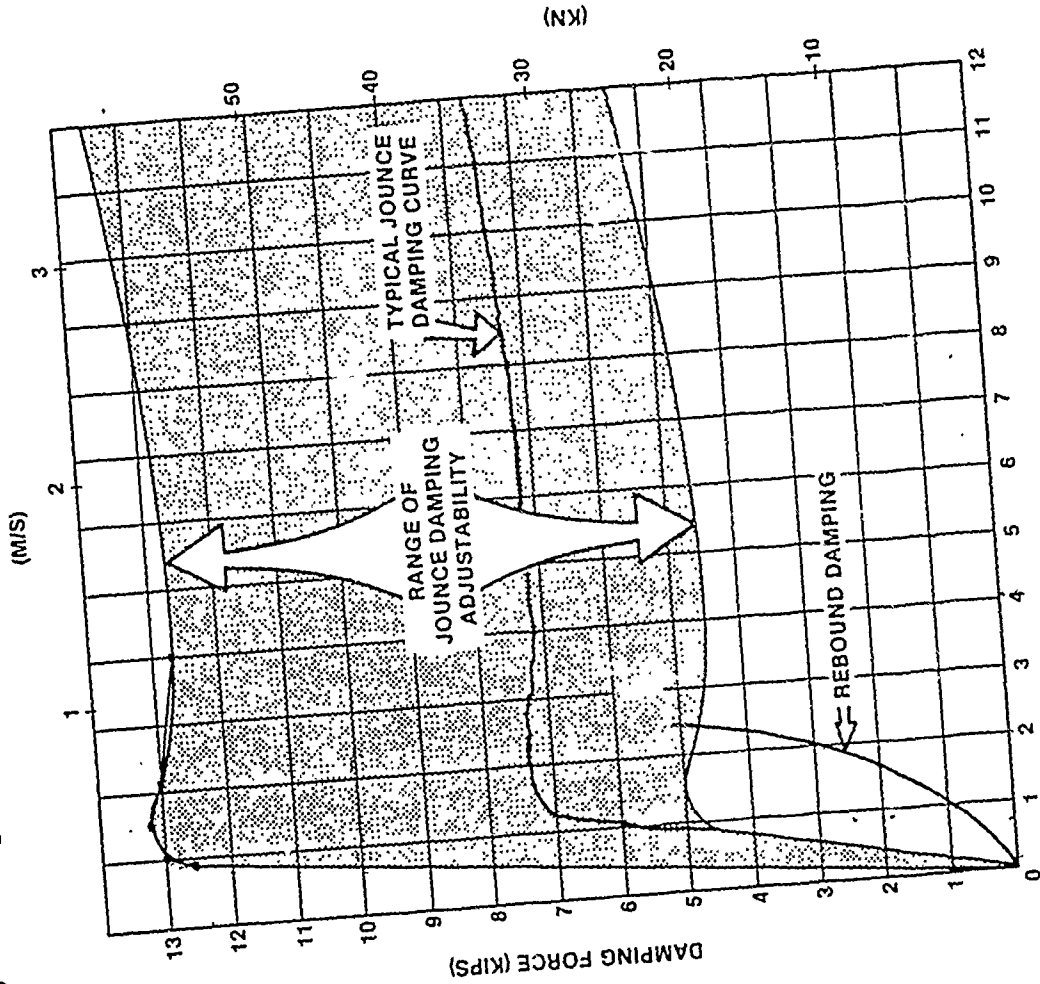

VERTICAL ROADWHEEL VELOCITY (FT/SEC)
VERTICAL ROADWHEEL VELOCITY - SUSPENSION DAMPING CURVE

(FIG 92) CATTB GEOMETRY - SUSPENSION DAMPING CURVE

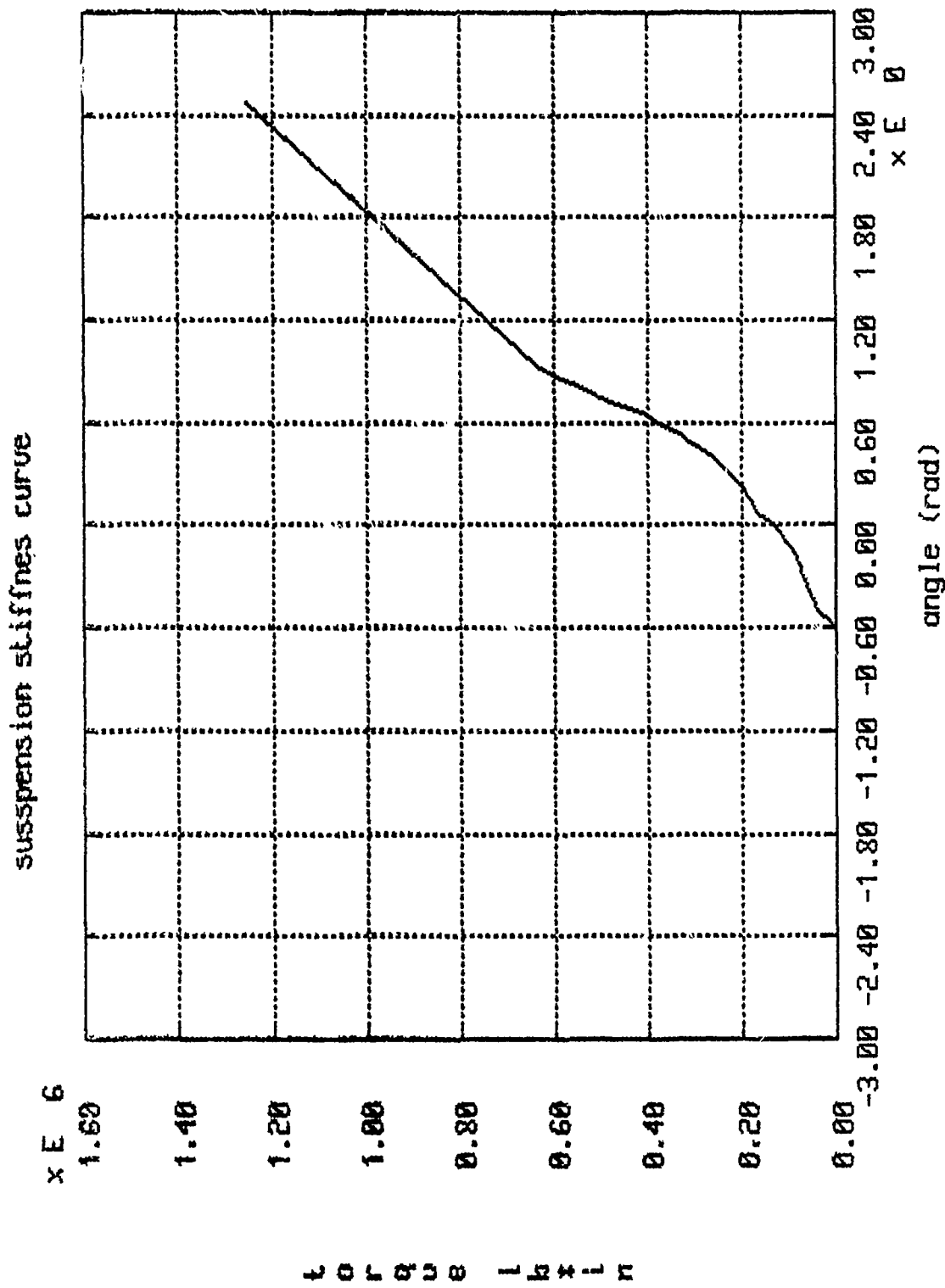

(FIG 93) CATTB GEOMETRY - DADS SUSPENSION CURVE

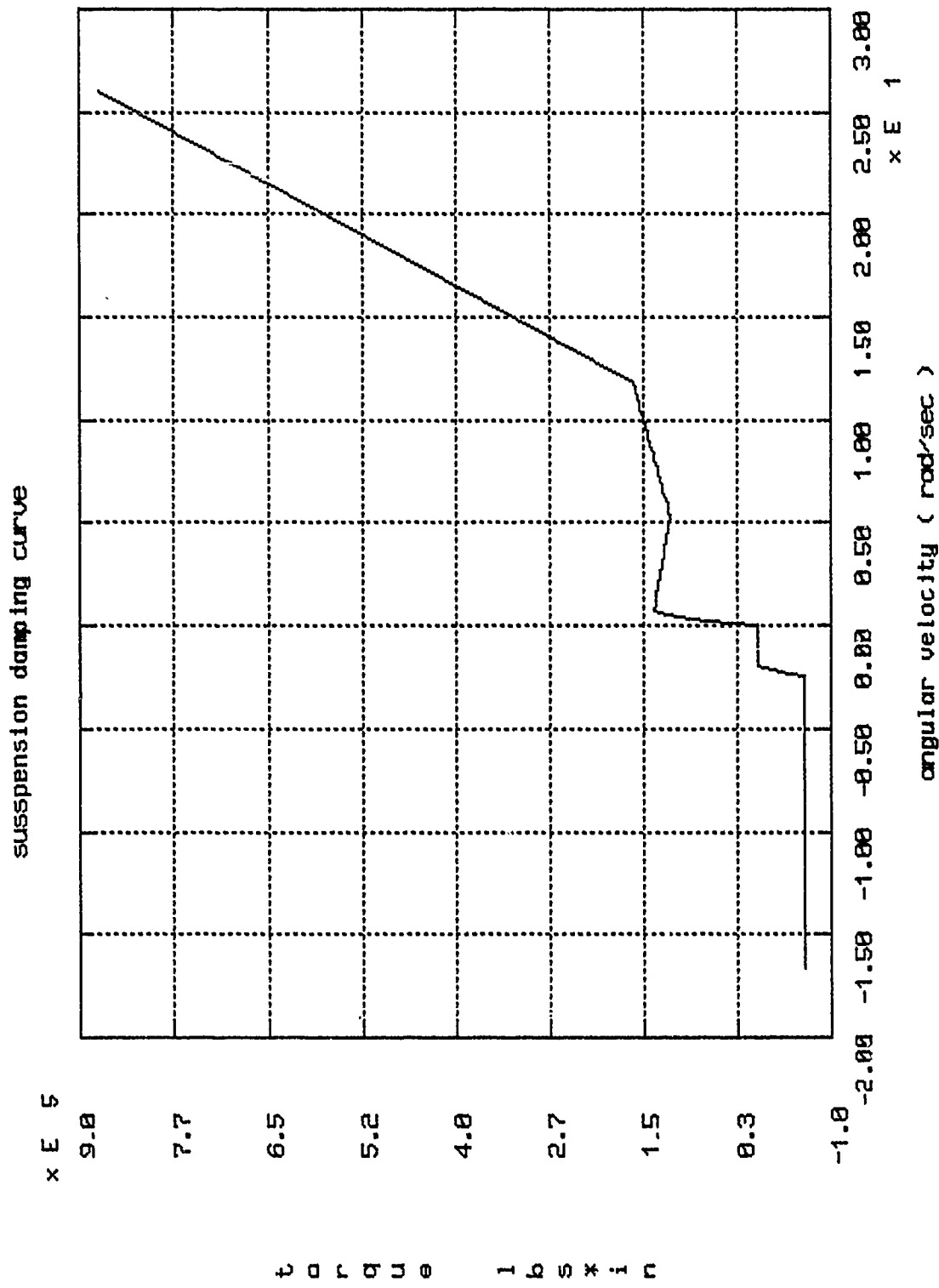

(FIG 94) CATTB GEOMETRY - DADS DAMPING CURVE

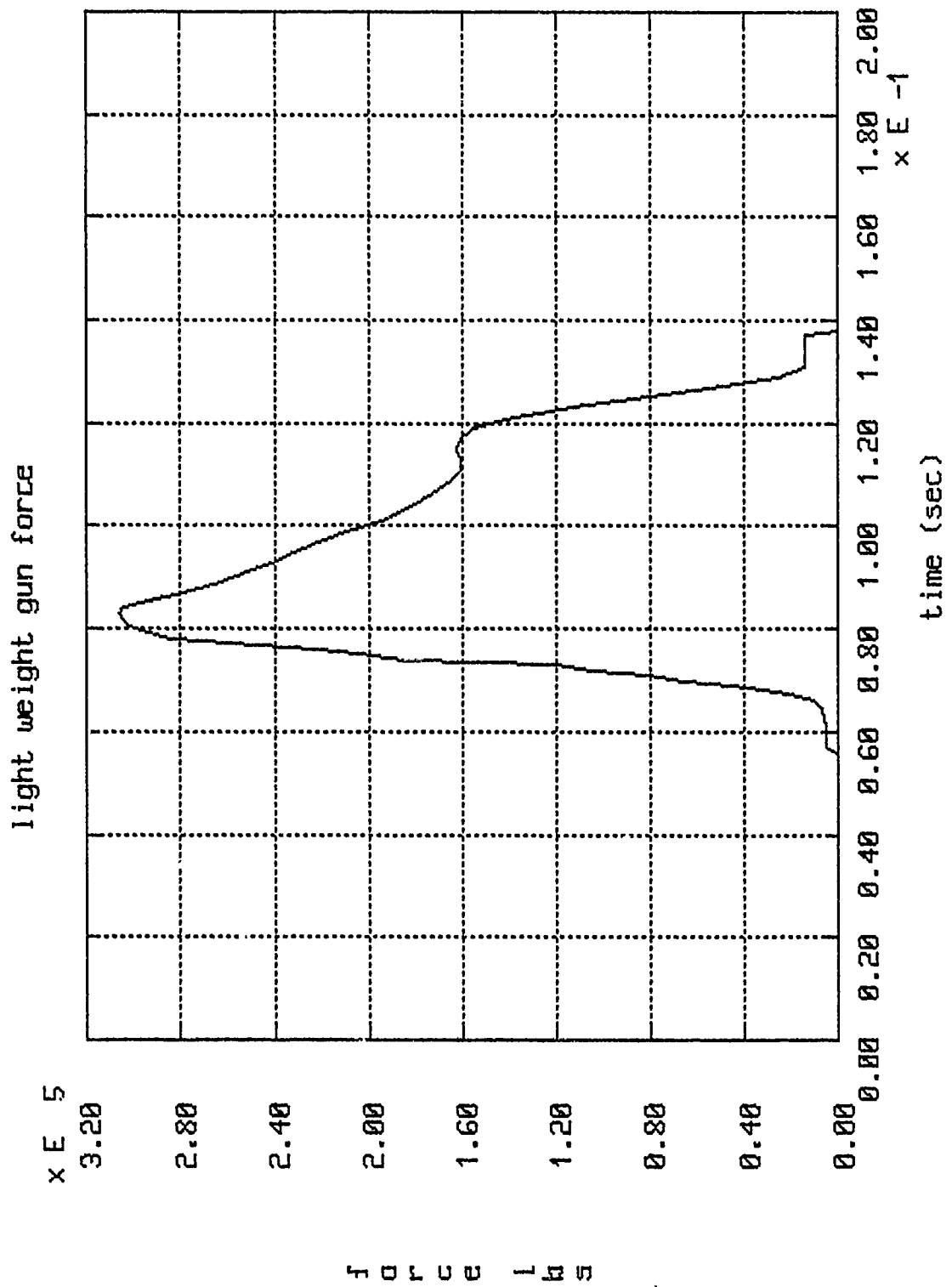

(FIG 95) CATTB GEOMETRY - DADS IMPULSE CURVE

ABG4 TERRAIN PROFILE

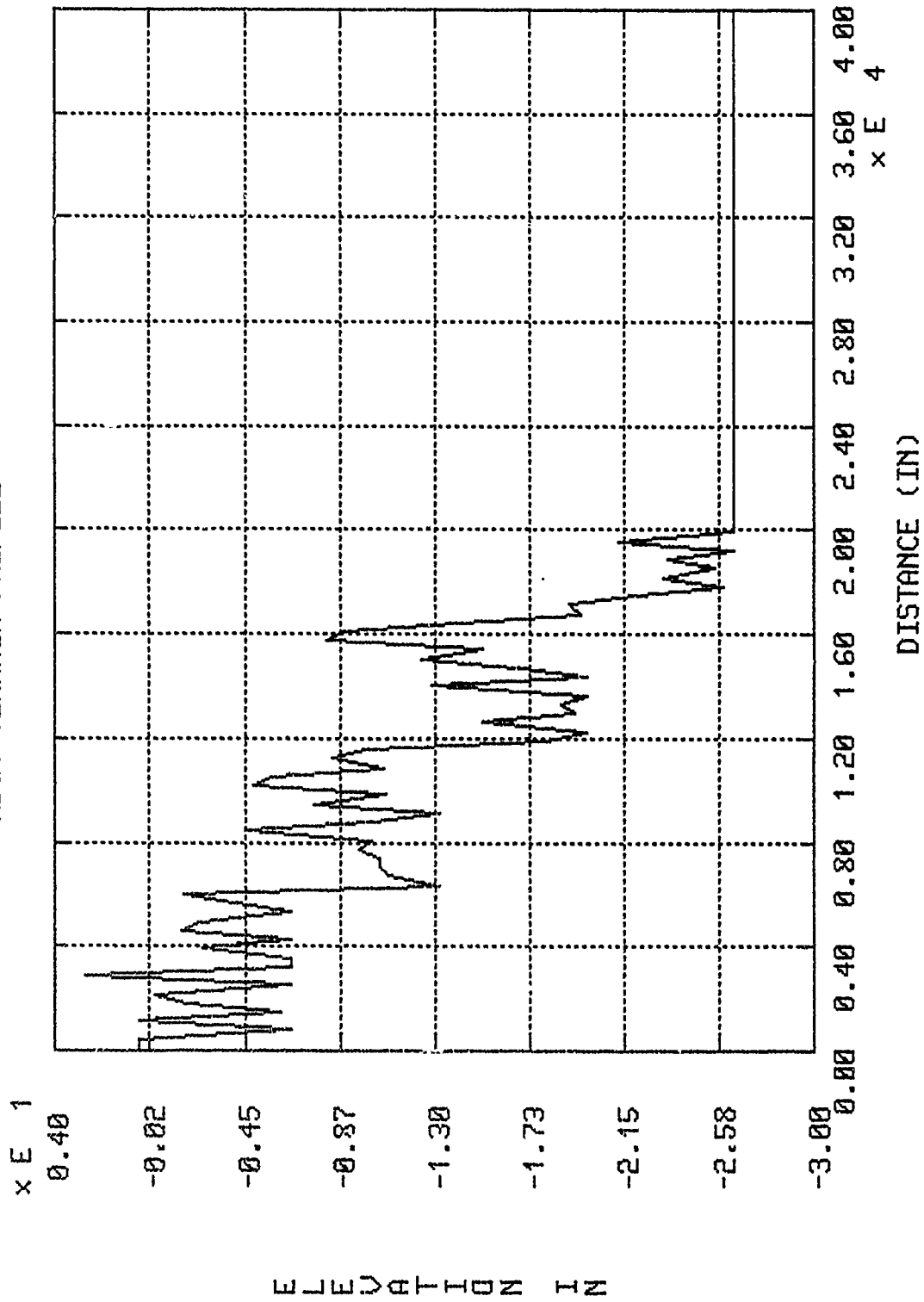

(FIG 96) CATTB GEOMETRY - DADS ABG4 TERRAIN CURVE

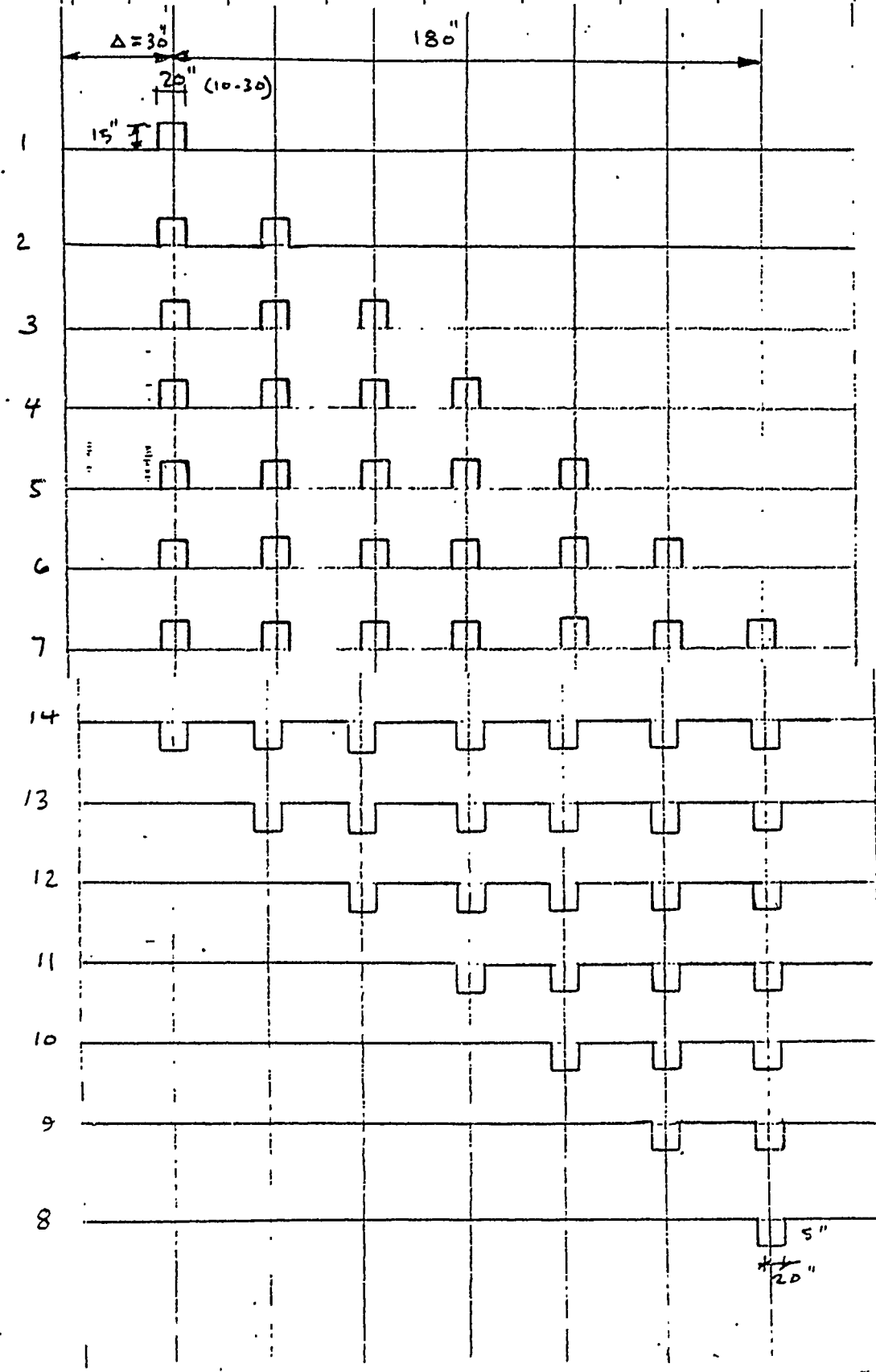
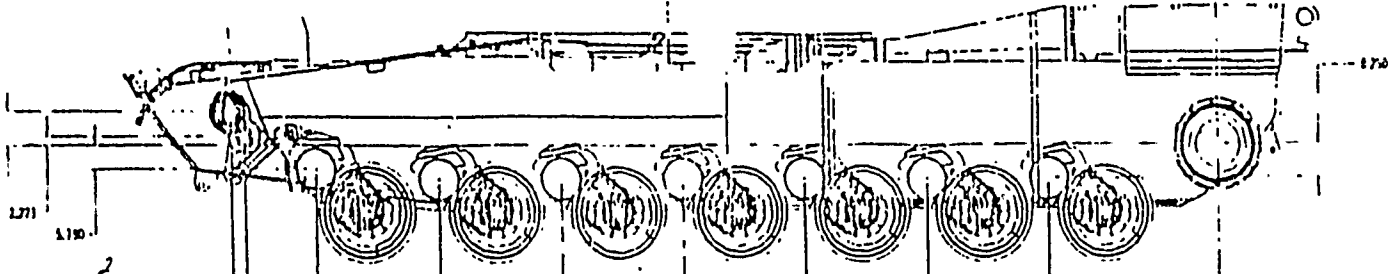

(FIG 97) CATB GEOMETRY - DADS CUSTOM TERRAIN CURVE

cattb roll and pitch angle at 30 M.P.H on APG4

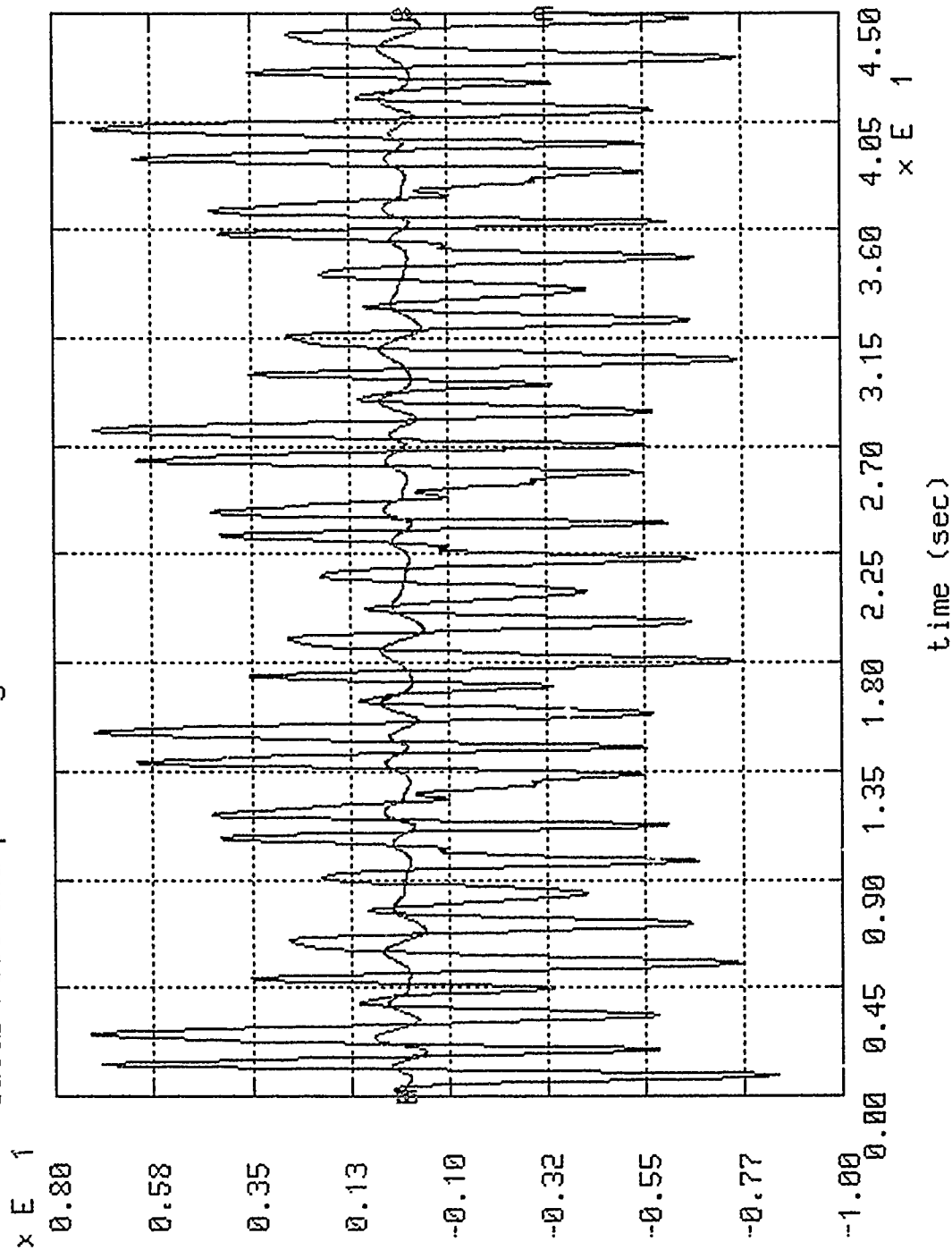

(FIG 98) CATTB ROLL AND PITCH ANGLE

VERTICAL ACCELERATION AT CHASSIS C.G AND FIRST ROAD WHEEL (G)

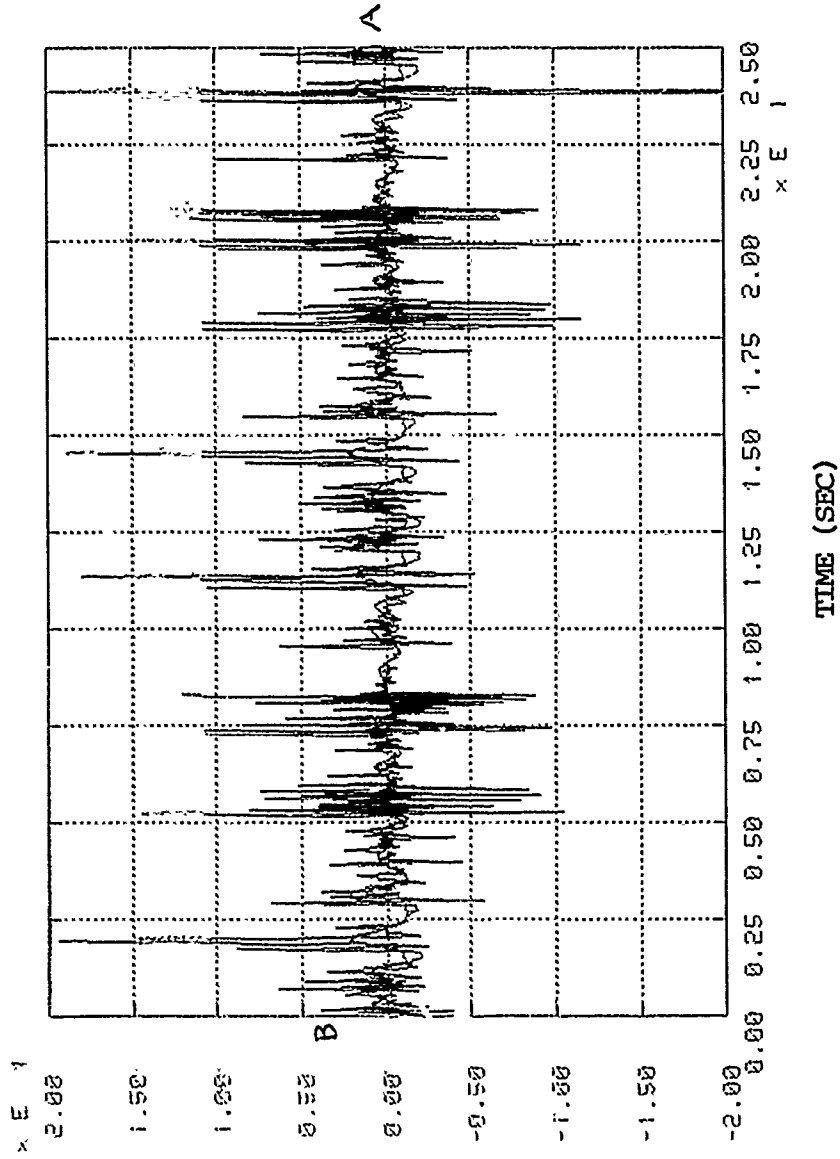

FIG 99
VERTICAL ACCELERATION AT CHASSIS C.G AND FIRST ROADWHEEL

VERTICAL FORCES IN ROAD WHEELS 1, 4 AND 7 (LBS)

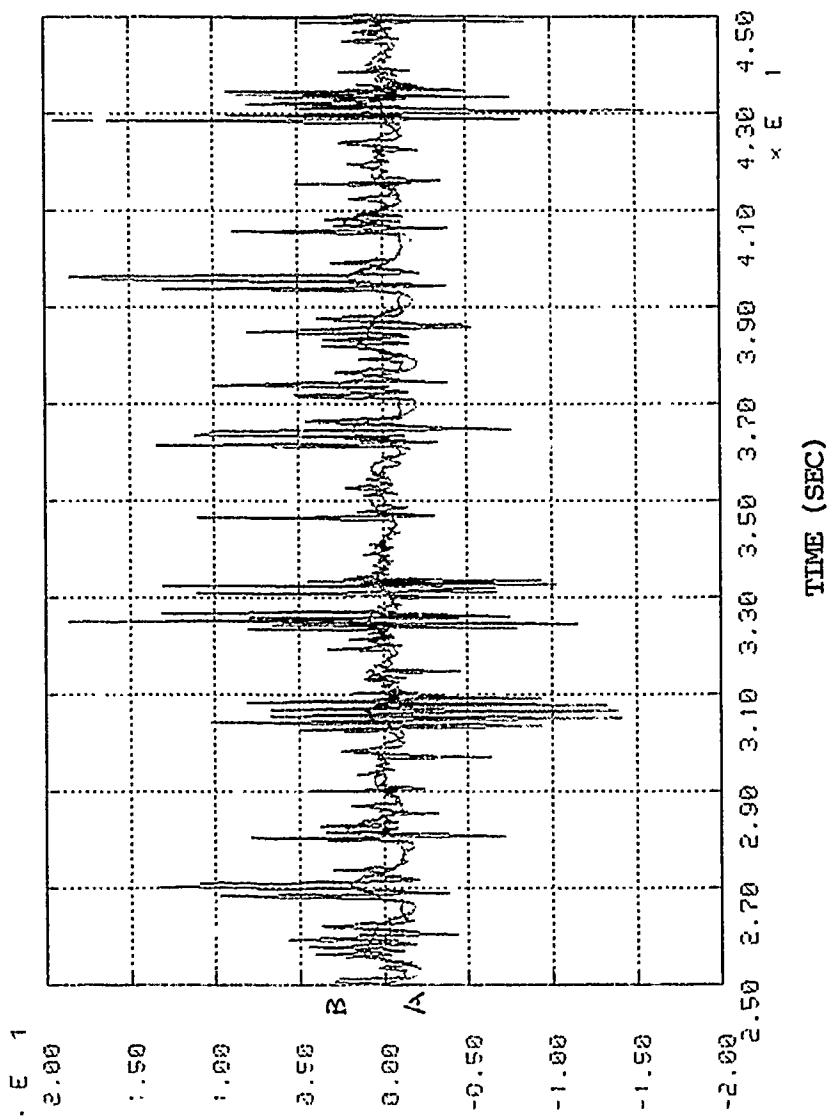

FIG 99

VERTICAL FORCES IN ROAD WHEELS 1, 4 and 7 (lbs)

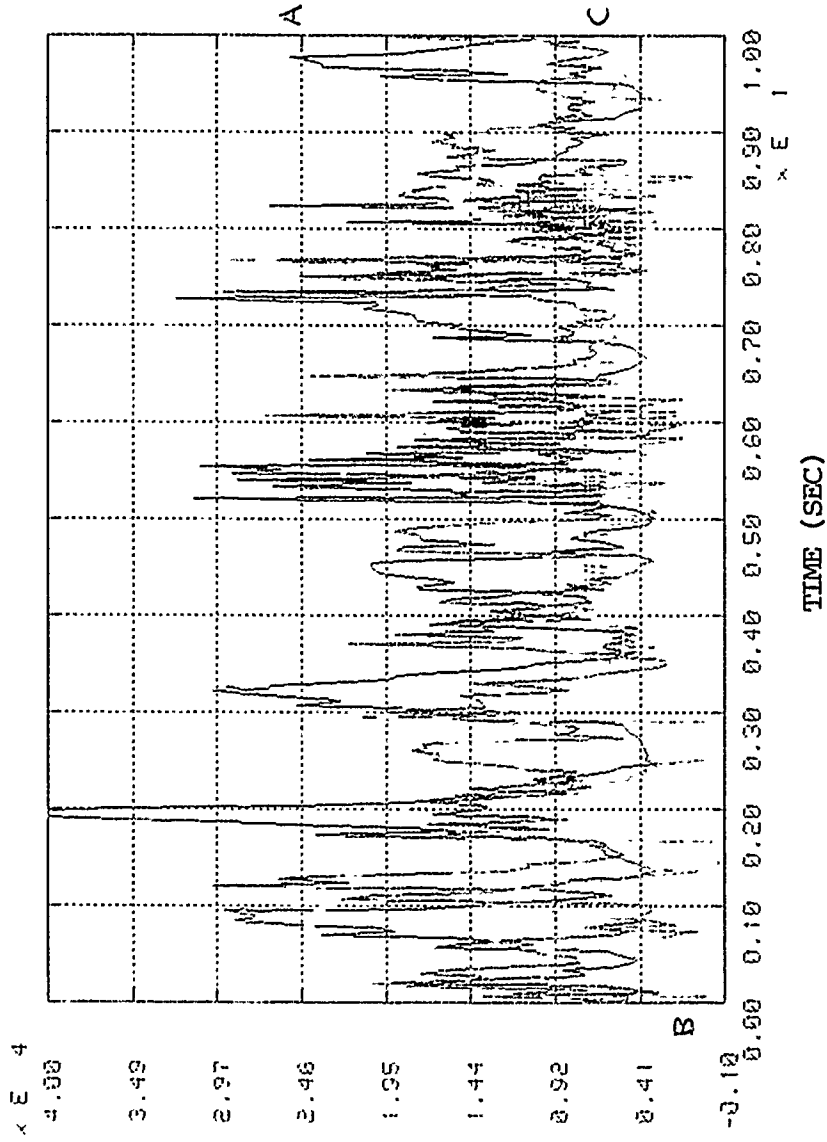

FIG 100
VERTICAL FORCES IN ROADWHEELS 1, 4, and 7

VERTICAL FORCES IN ROAD WHEELS 1, 4 and 7 (lbs)

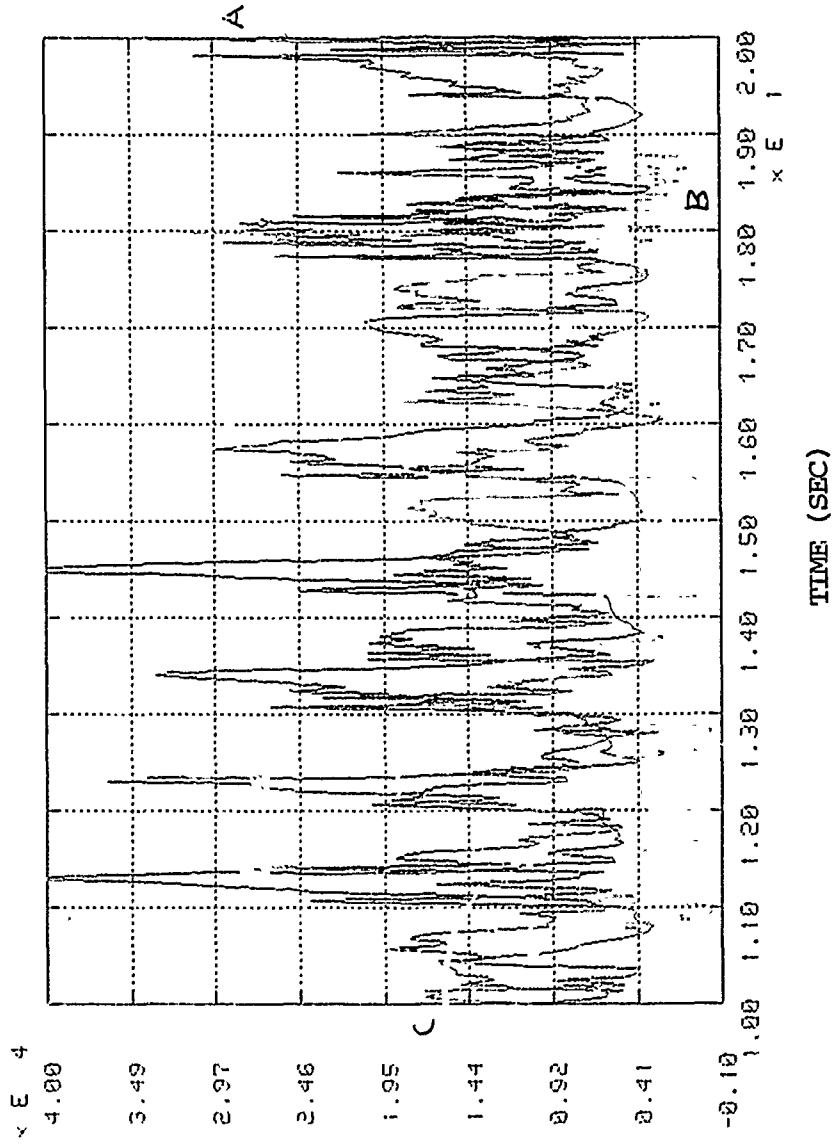

FIG 100

VERTICAL FORCES IN ROAD WHEELS 1, 4 and 7 (lbs)

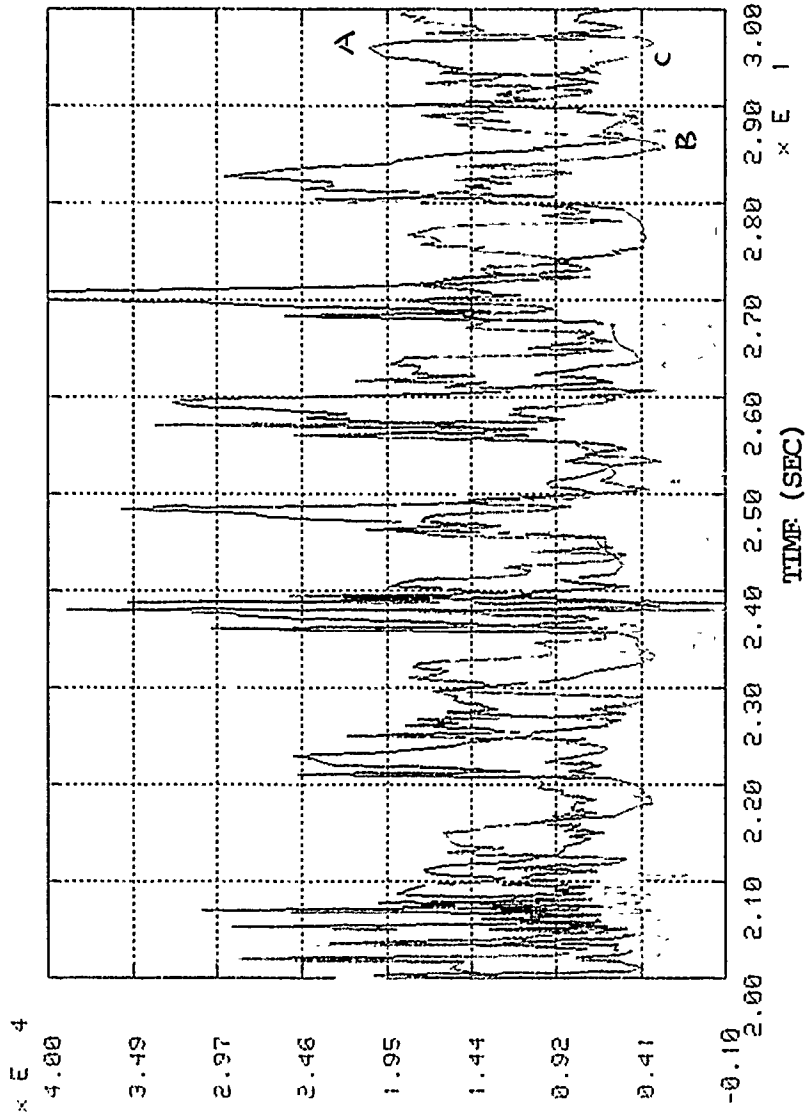

FIG 100

VERTICAL FORCES IN ROAD WHEELS 1, 4 and 7 (lbs)

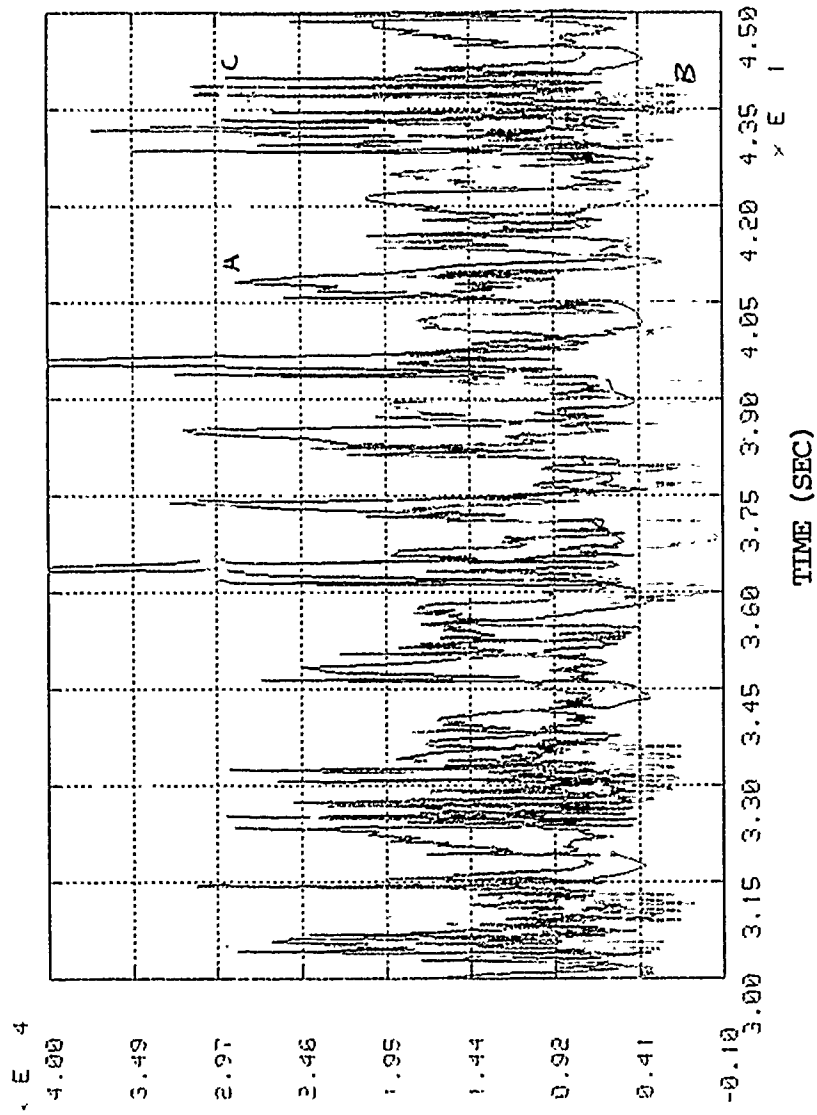

FIG 100

VERTICAL FORCES IN ROAD WHEELS 2, 3, 5 AND 6 (LBS)

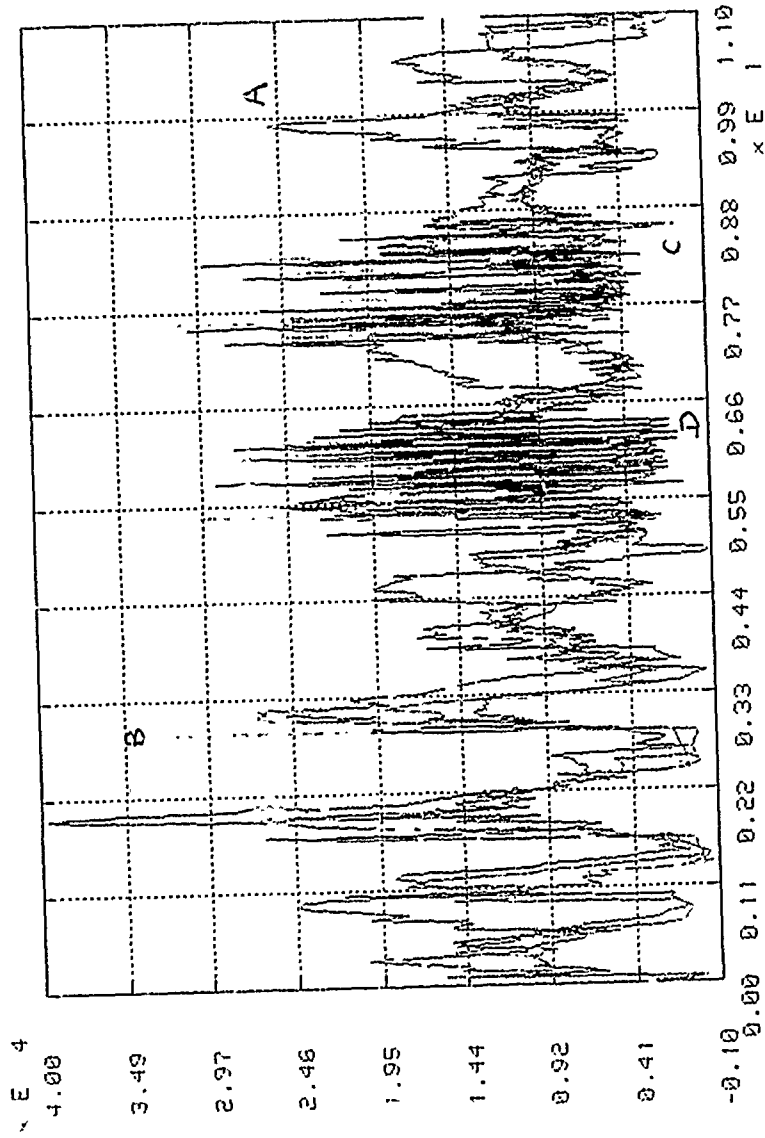

FIG 101
VERTICAL FORCES IN ROADWHEELS 2, 3, 5, and 6

VERTICAL FORCES IN ROAD WHEELS 2, 3, 5 and 6 (lbs)

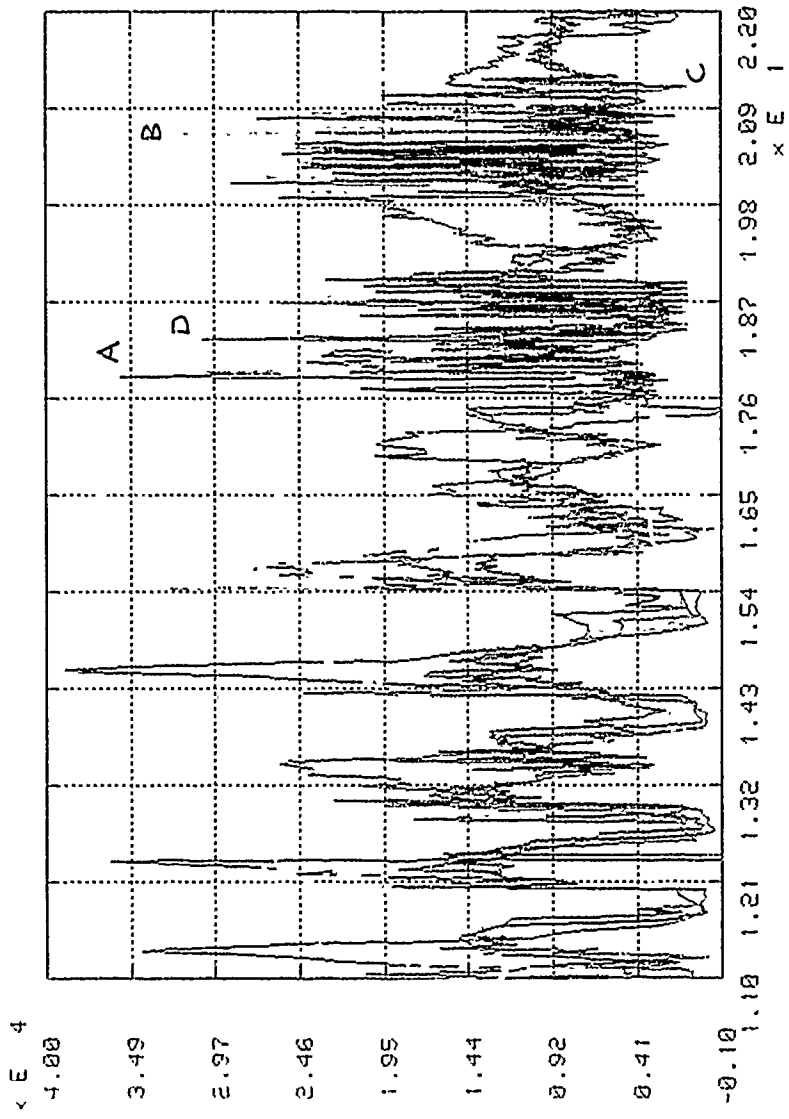

FIG 101

VERTICAL FORCES IN ROAD WHEELS 2, 3, 5 and 6 (lbs)

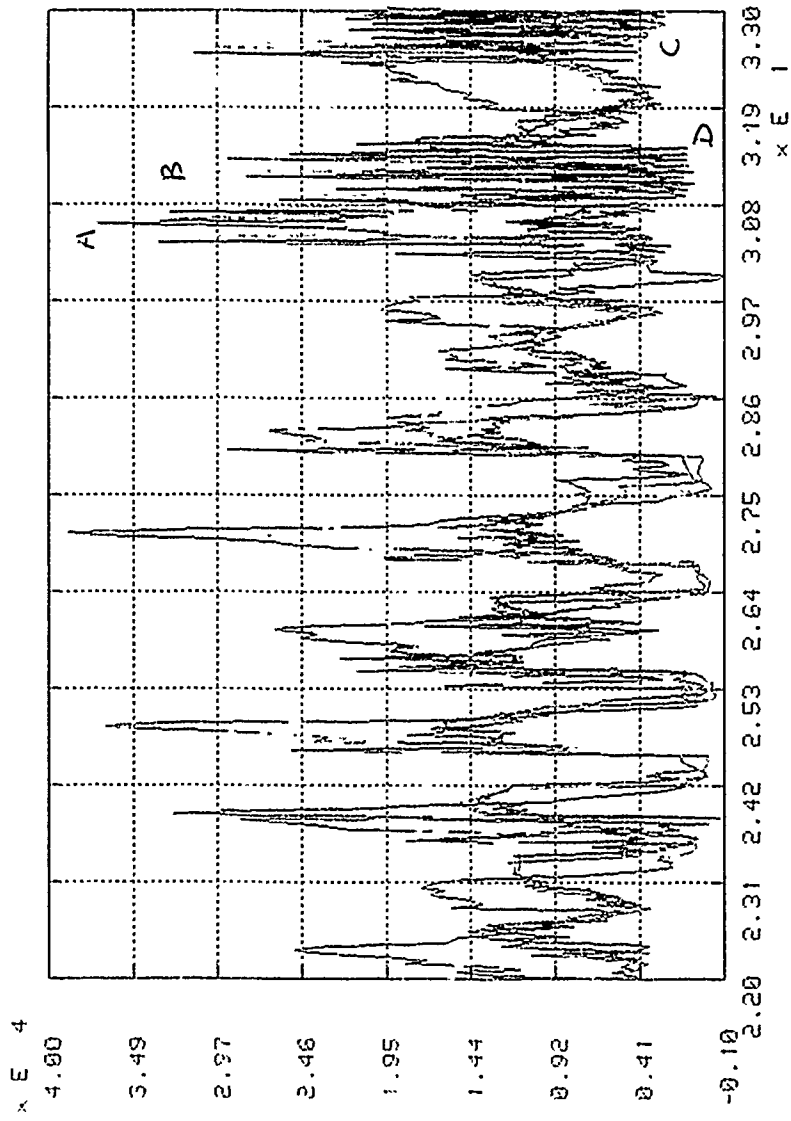

FIG 101

VERTICAL FORCES IN ROAD WHEELS 2, 3, 5 and 6 (lbs)

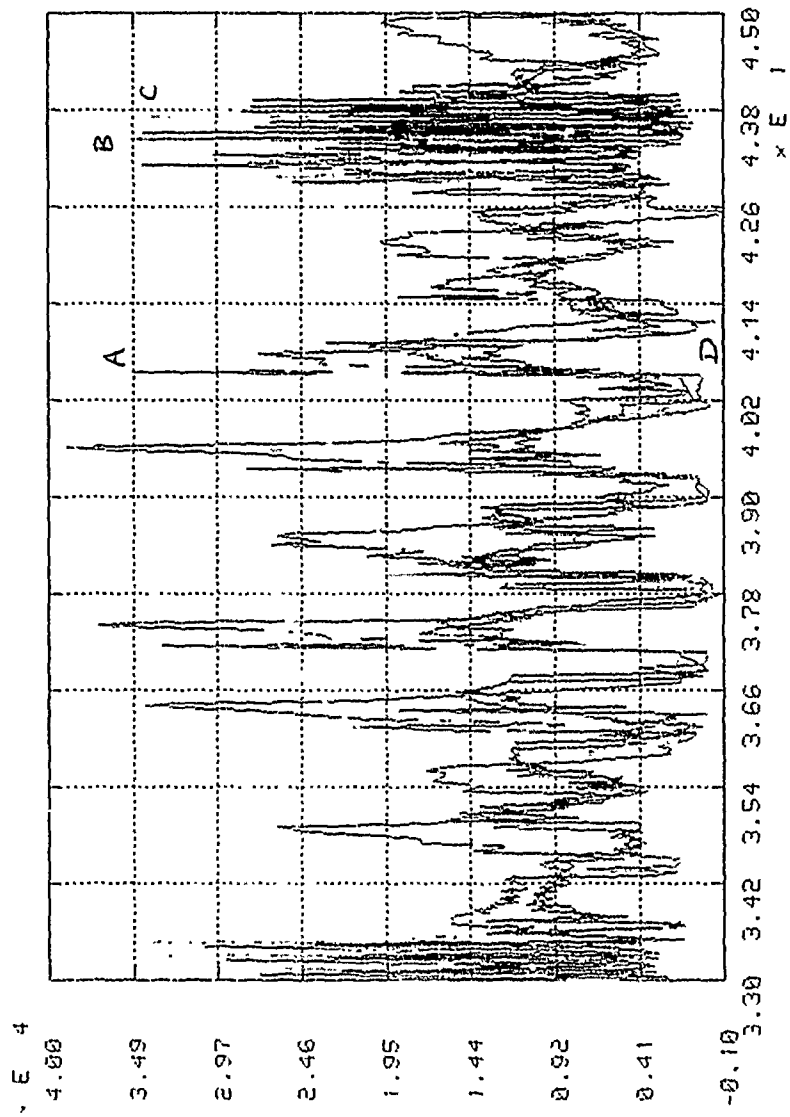

FIG 101

chassis acceleration due to terrain a long. b vertical

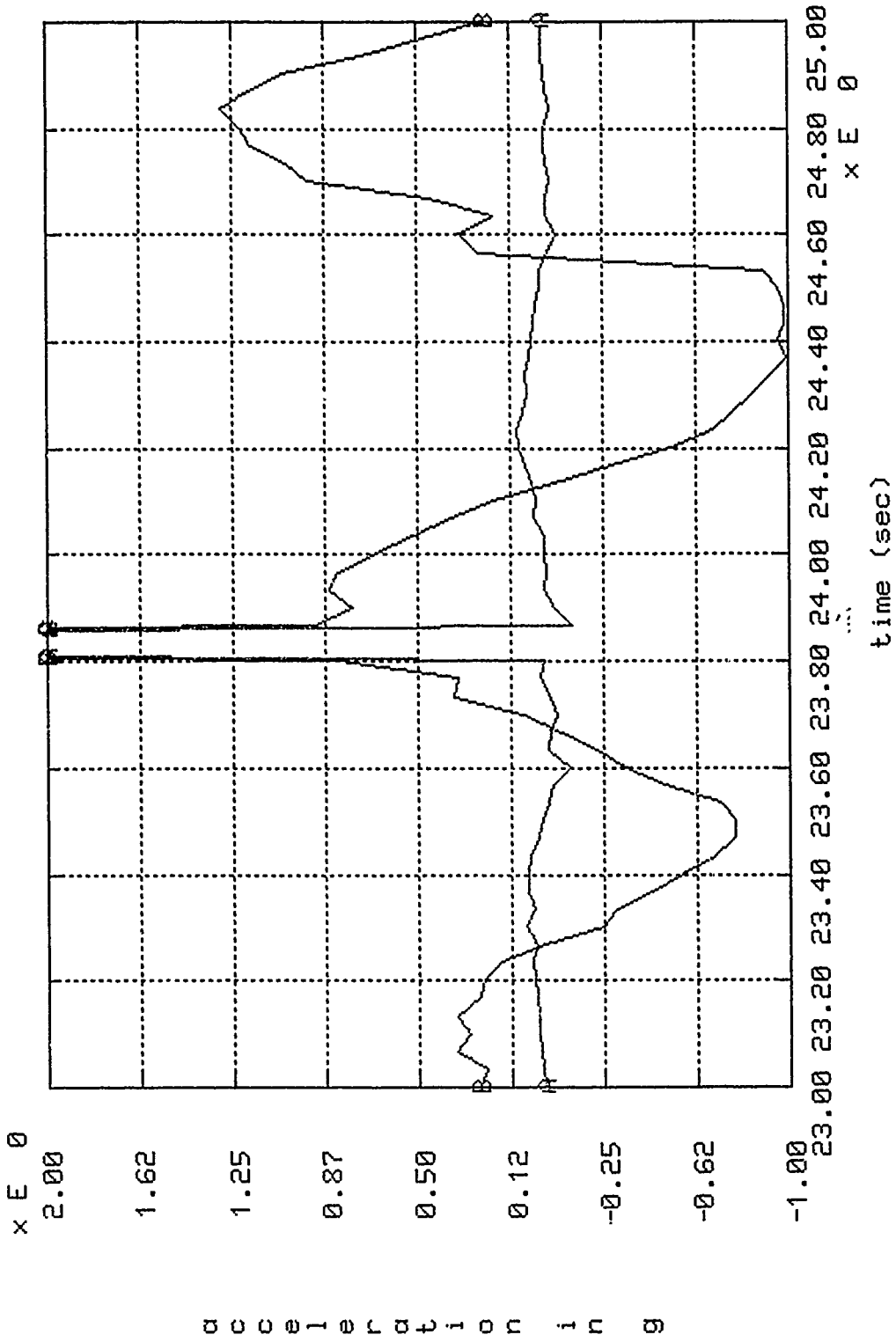

FIG 102
MAXIMUM CHASSIS ACCELERATION

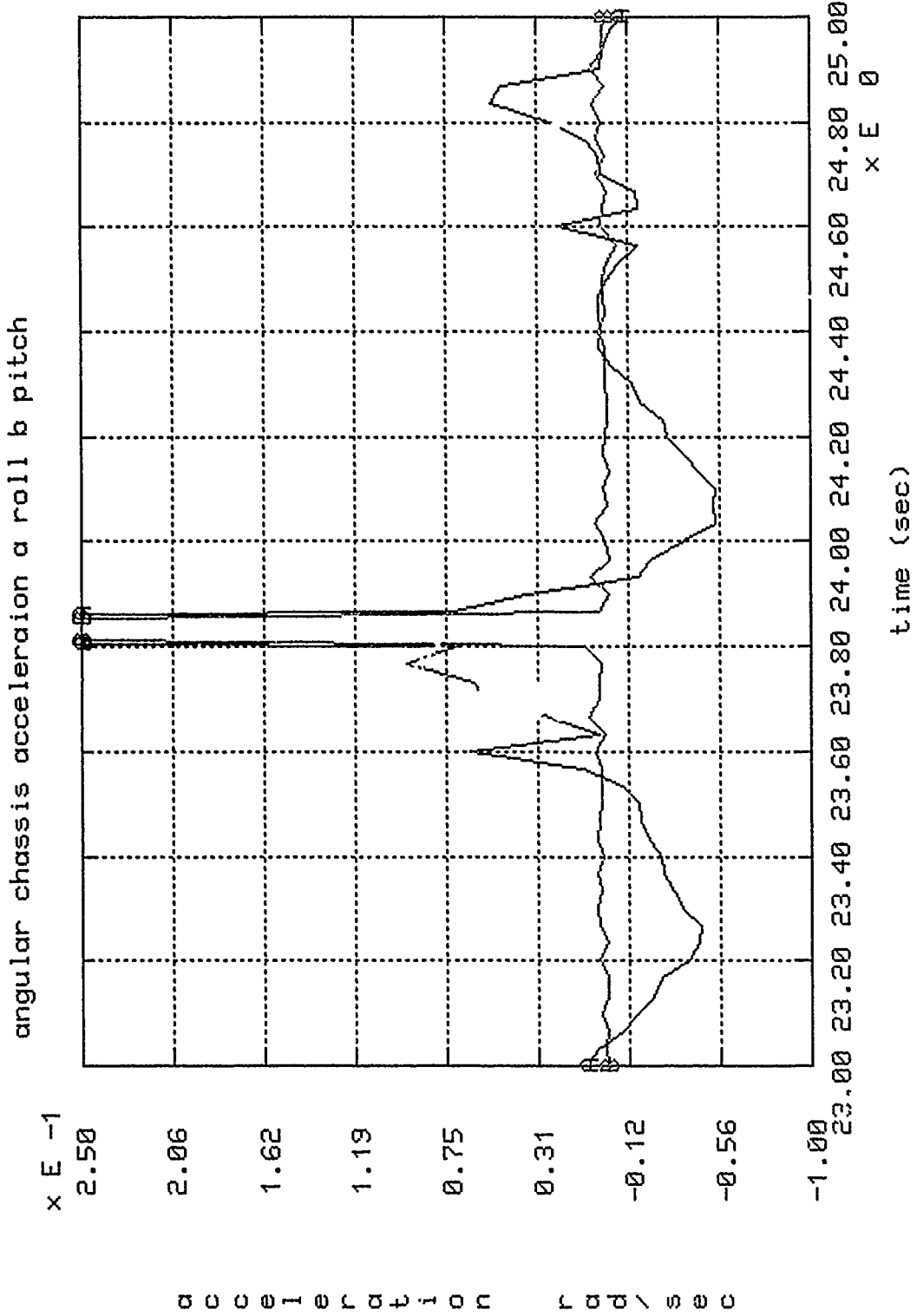

FIG 103
 MAXIMUM CHASSIS ANGULAR ACCELERATION

terrain forces on road wheels 1, 4, 7

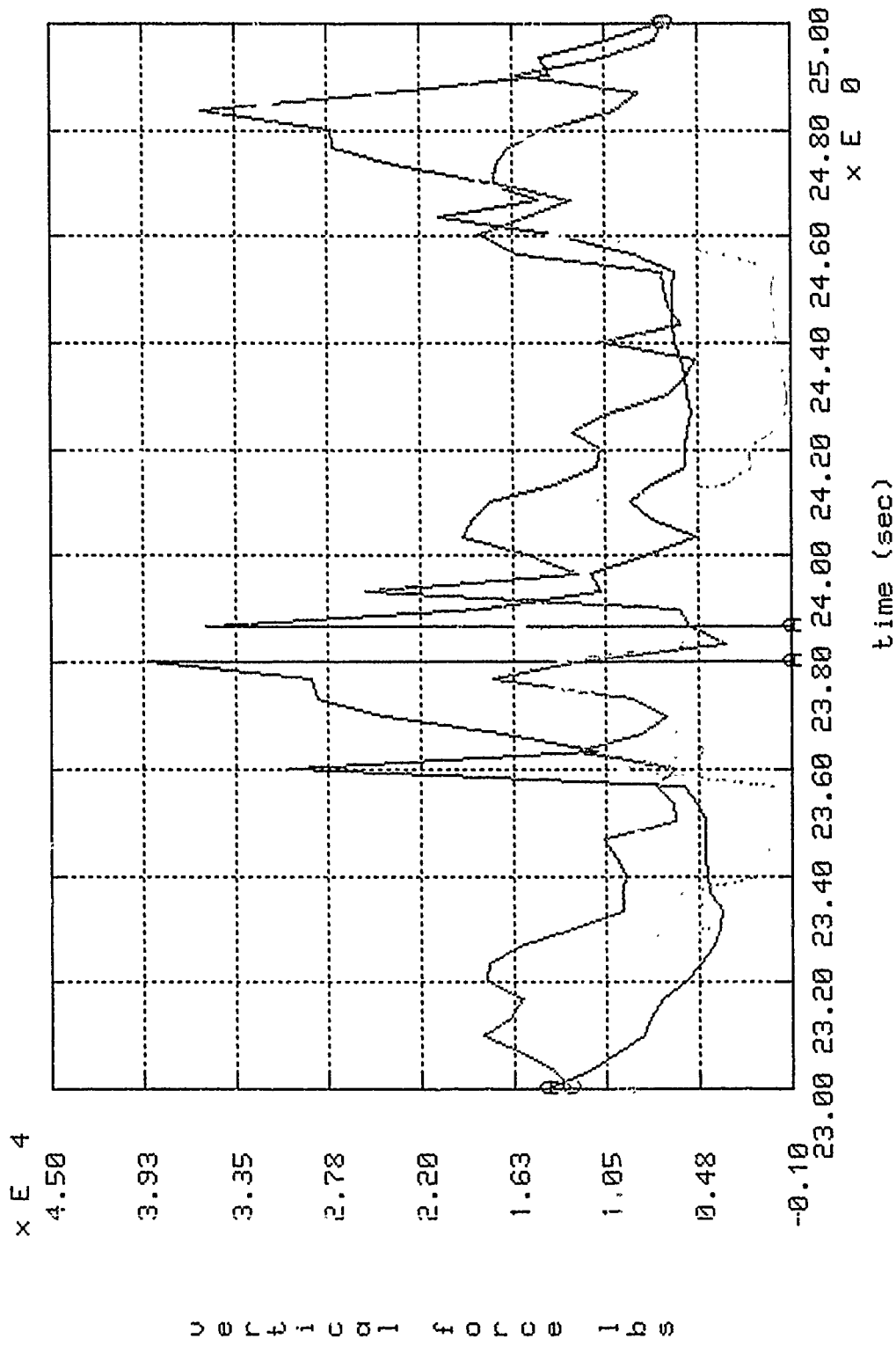

FIG 104
MAXIMUM FORCES IN ROADWHEELS 1, 4, and 7 (CASE 1)

terrain forces on road wheels 2,3,4,5

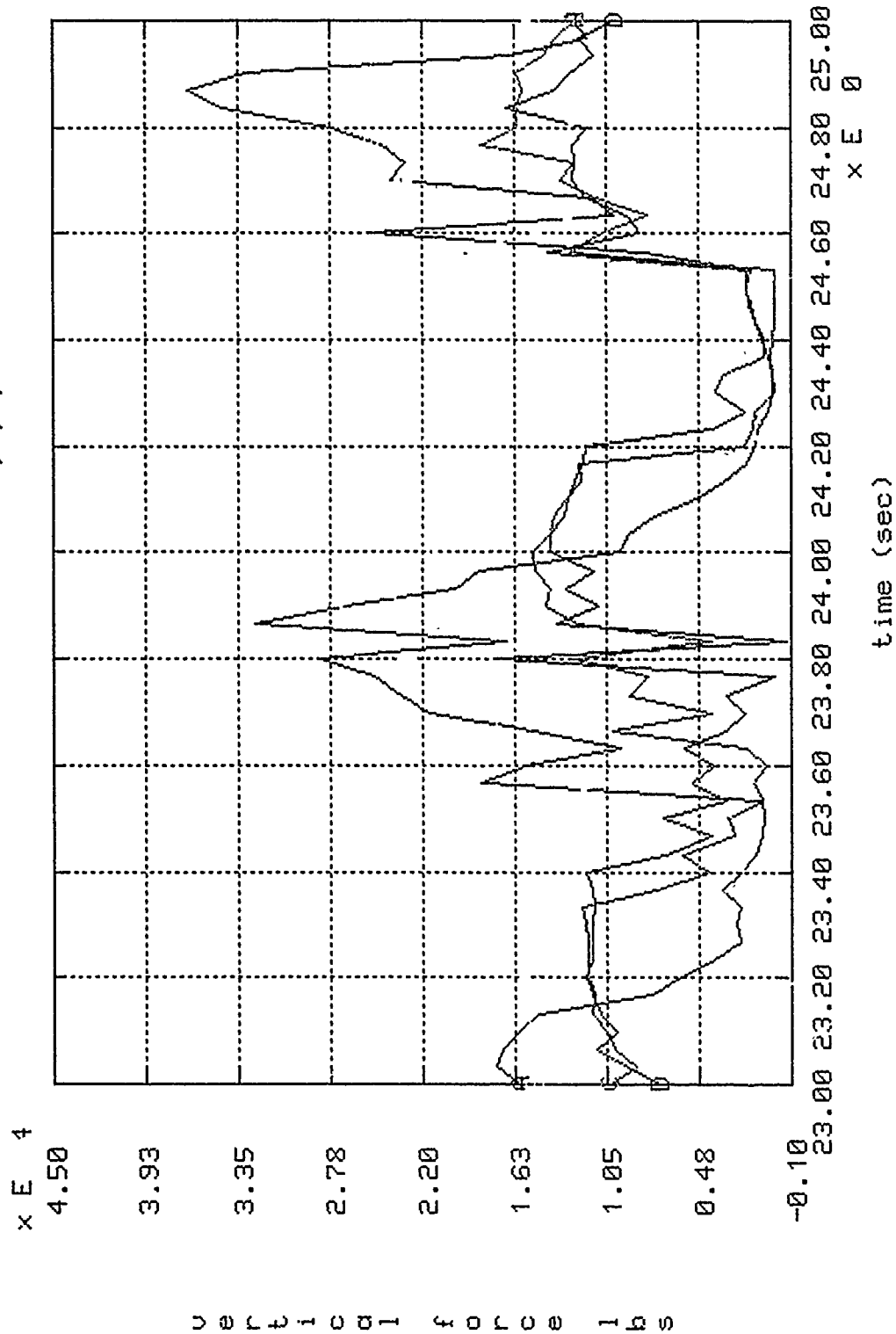

FIG 105
MAXIMUM FORCES IN ROADWHEELS L2: 3, 5, and 6 (CASE 1)

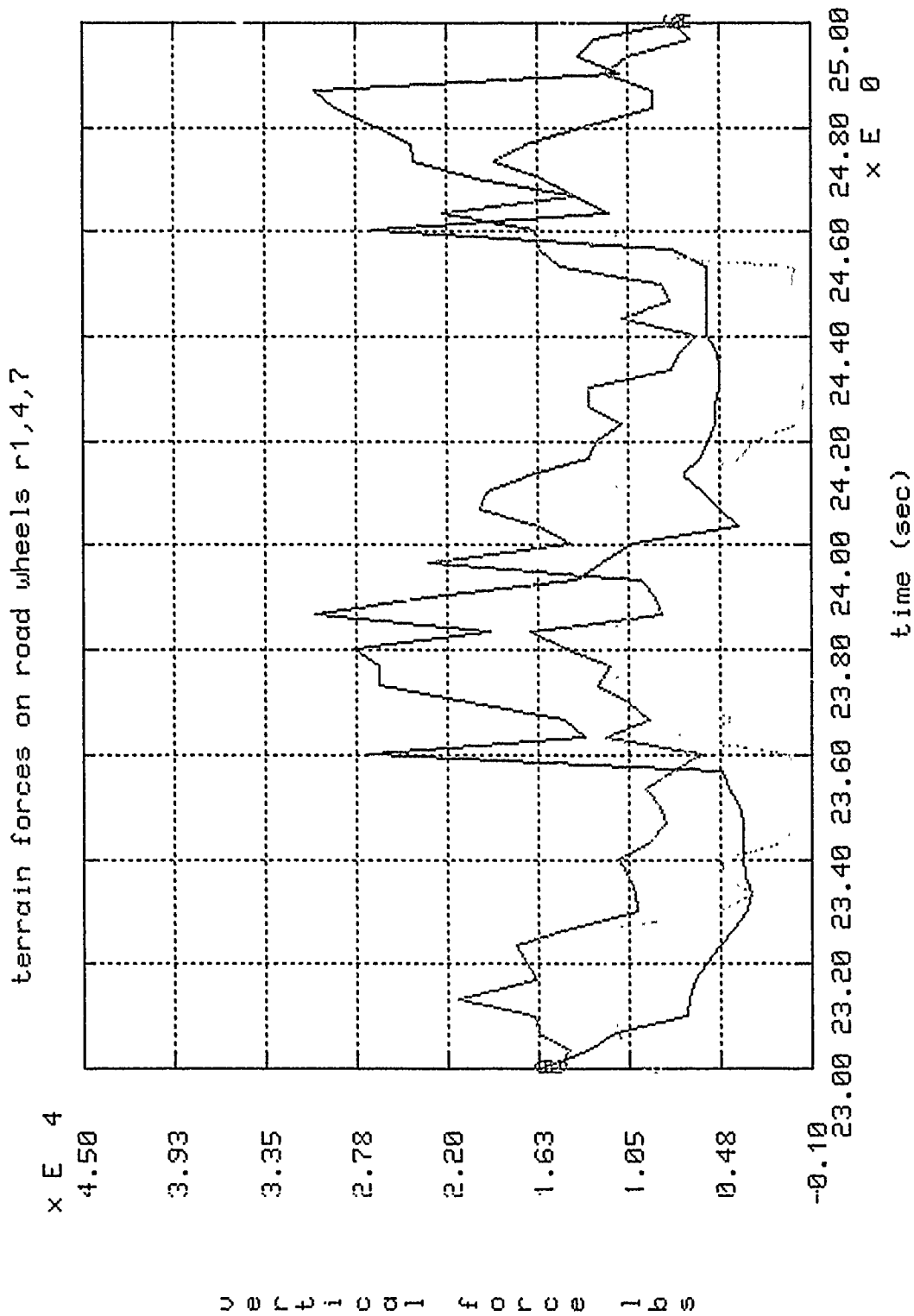

FIG 106
MAXIMUM FORCES IN ROADWHEELS R1, 4, and 7 (CASE 1)

terrain forces on road wheels r2,3,5,6

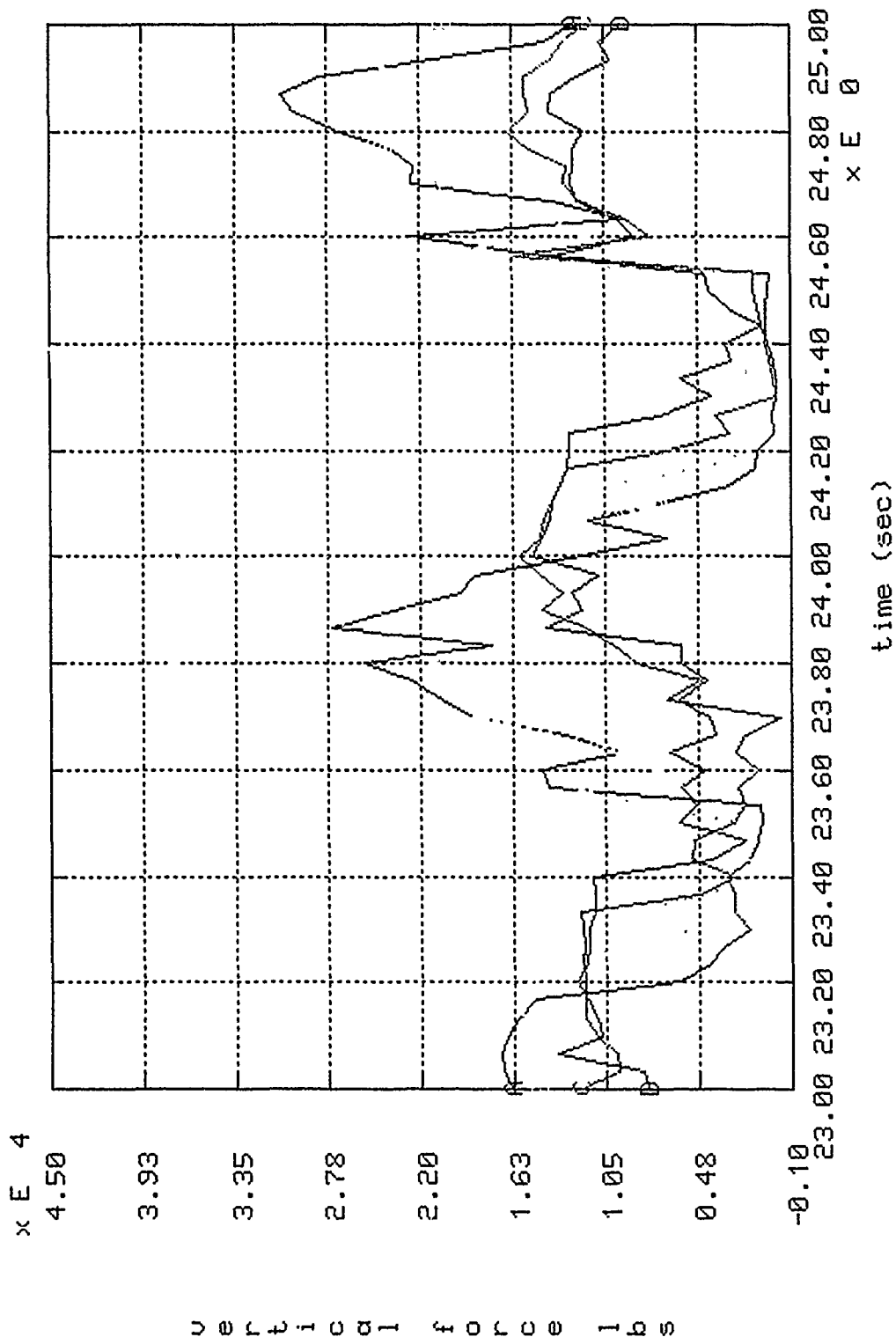

FIG 107
MAXIMUM FORCES IN ROADWHEELS R2, 3, 5, and 6 (CASE 1)

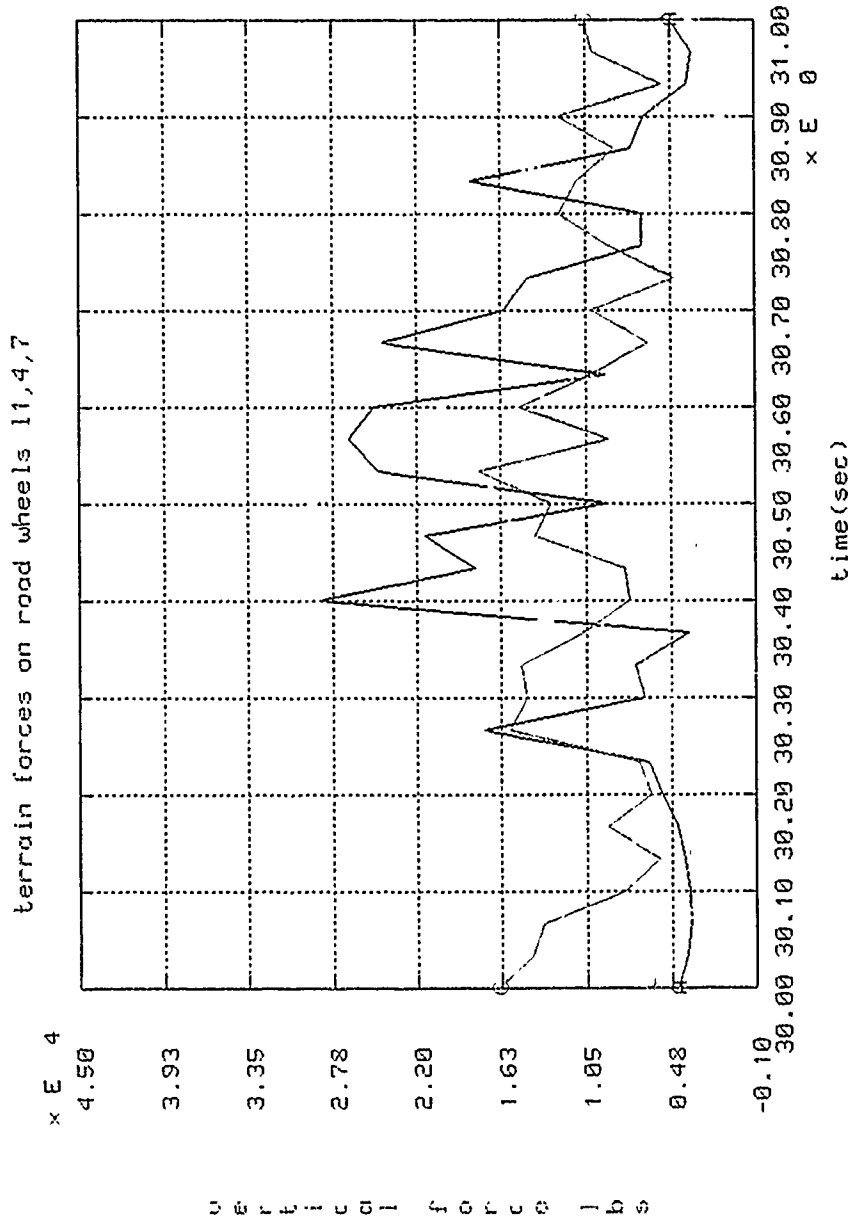

FIG 108
MAXIMUM FORCES IN ROADWHEELS L1, 4, 7 (CASE 2)

terrain forces on road wheels 12,3,5,6

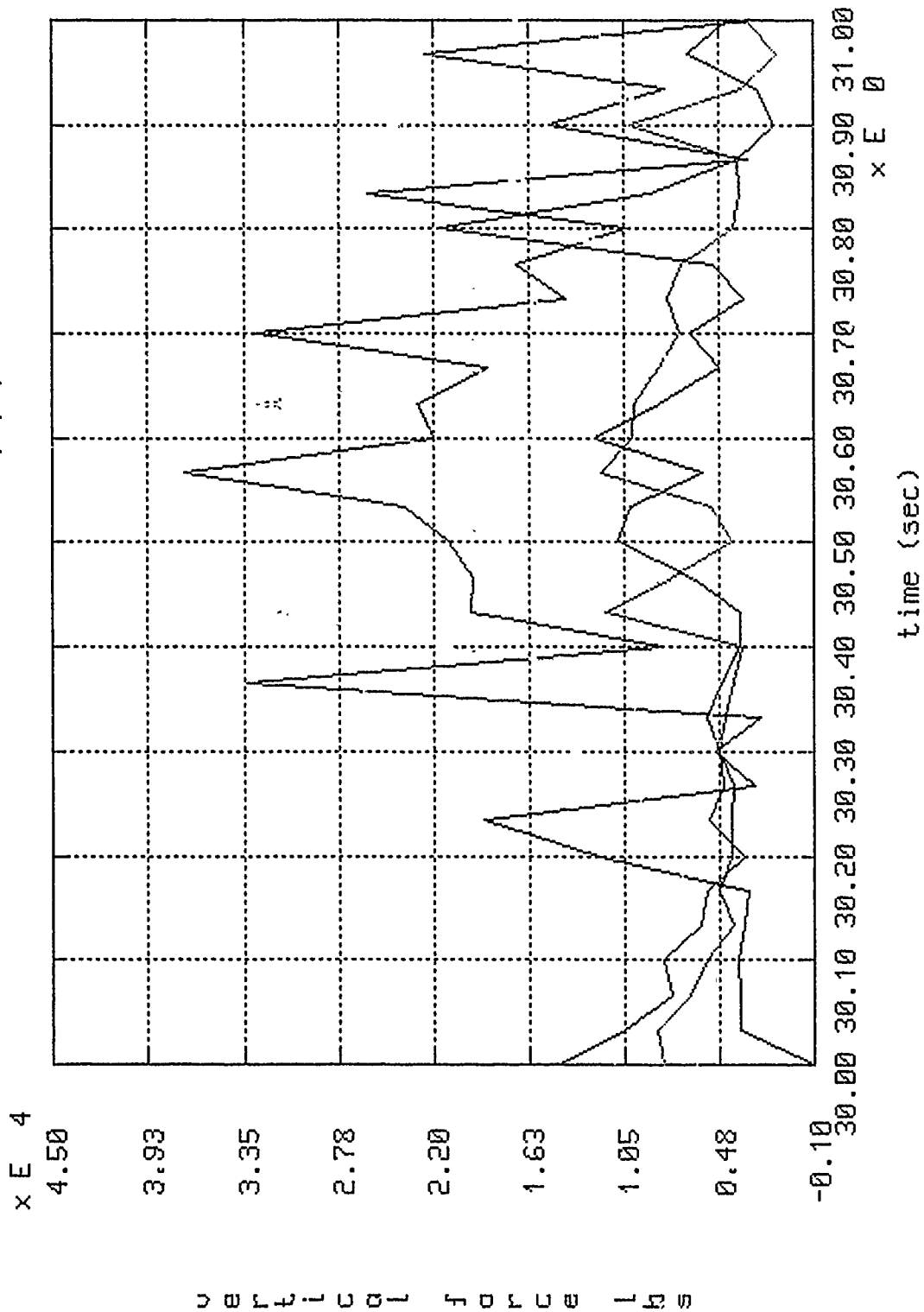

FIG 109
MAXIMUM FORCES IN ROADWHEELS L2, 3, 5, 6 (CASE 2)

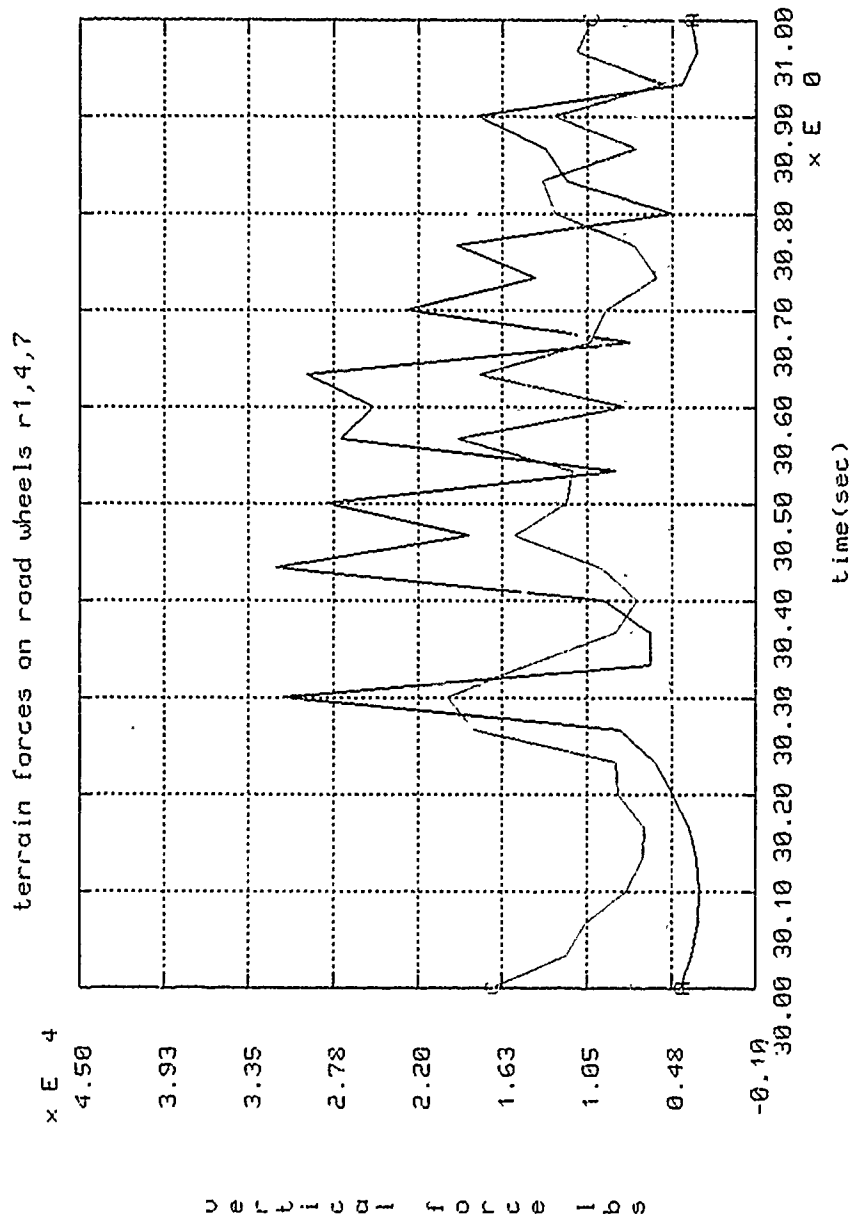

FIG 110
MAXIMUM FORCES IN ROADWHEELS R1, 4, and 7 (CASE 2)

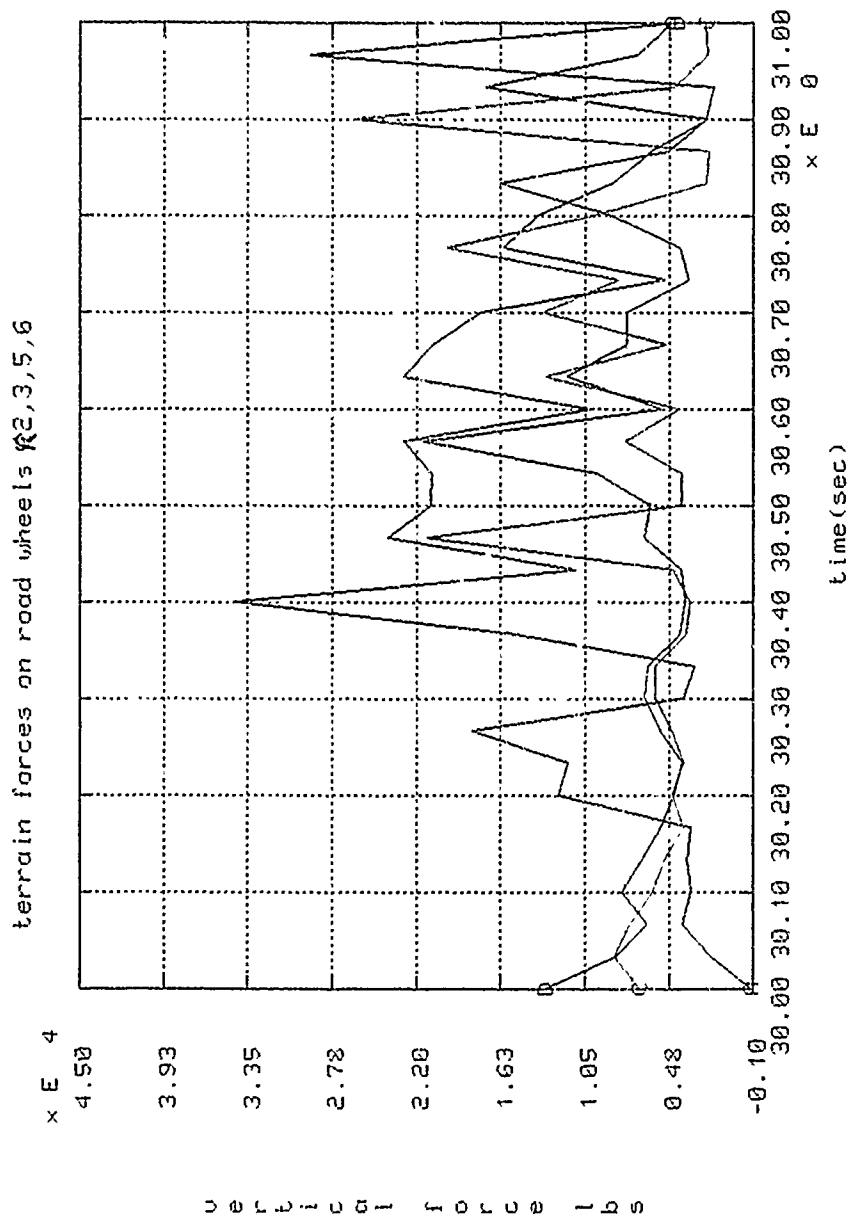

FIG 111
MAXIMUM FORCES IN ROADWHEELS R2, 3, 5, and 6 (CASE 2)

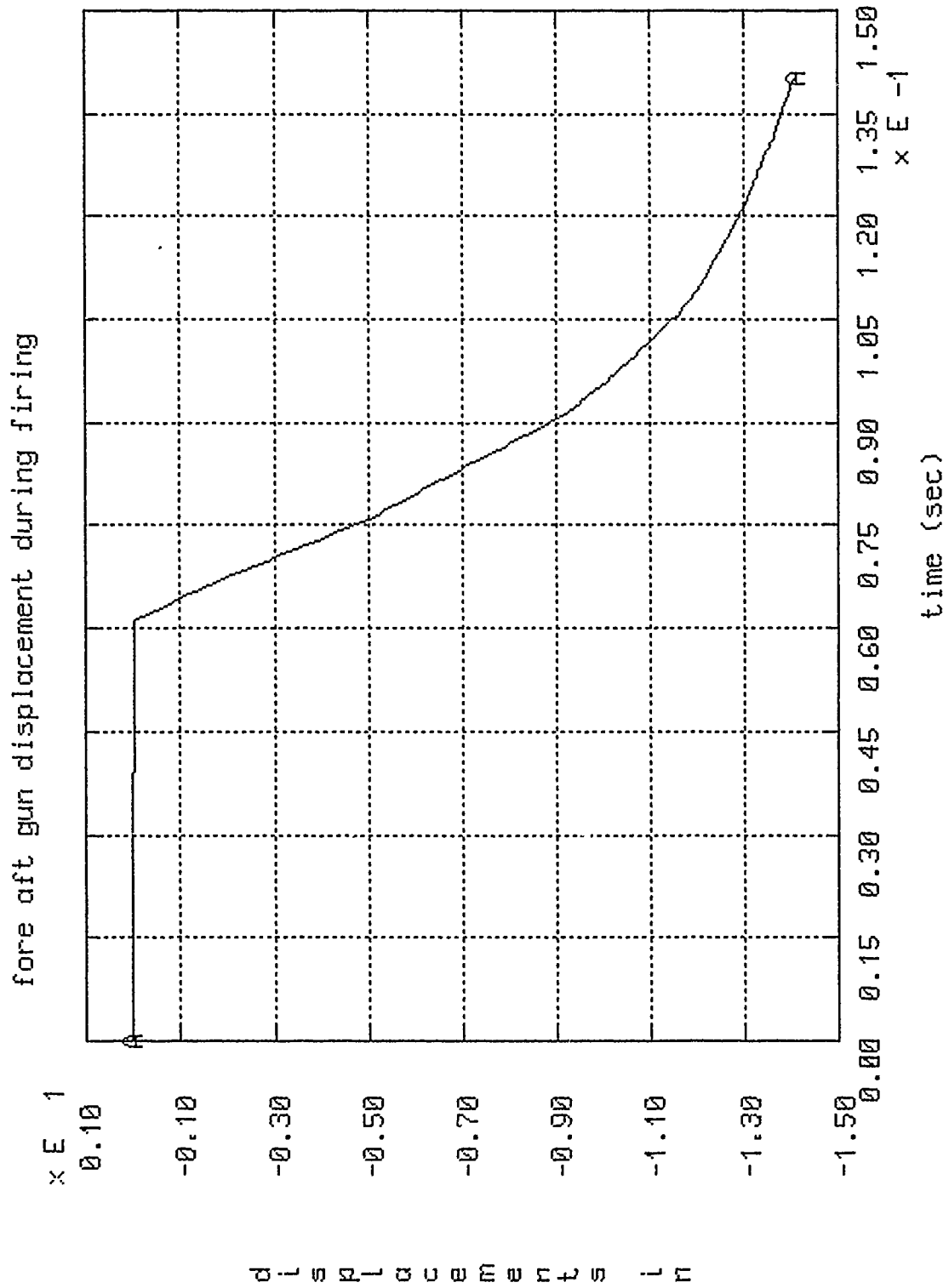

FIG 112
FORE -- AFT GUN DISPLACEMENT DURING FIRING

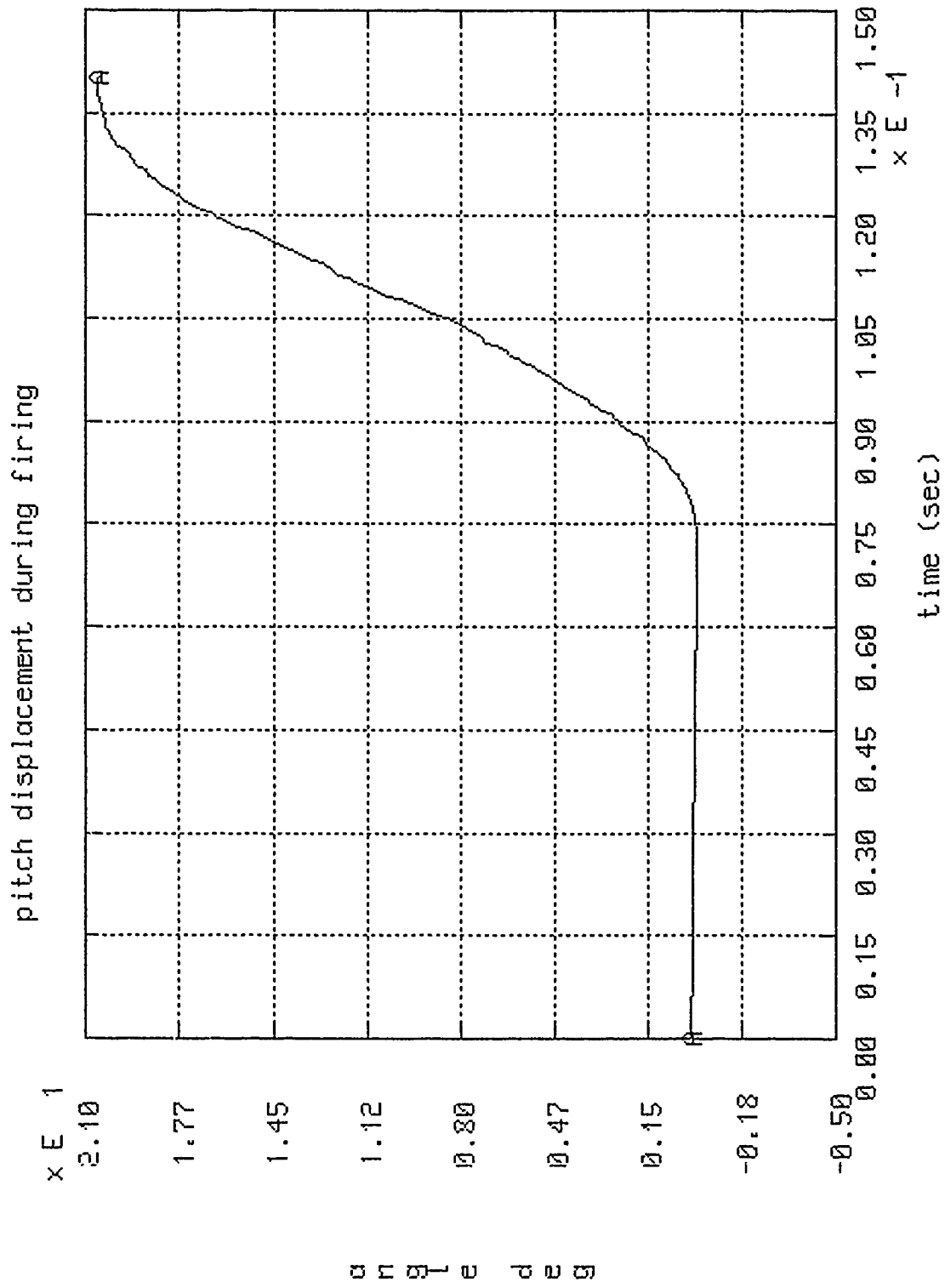

FIG 113
PITCH DISPLACEMENT DURING FIRING

fore aft gun velocity during firing

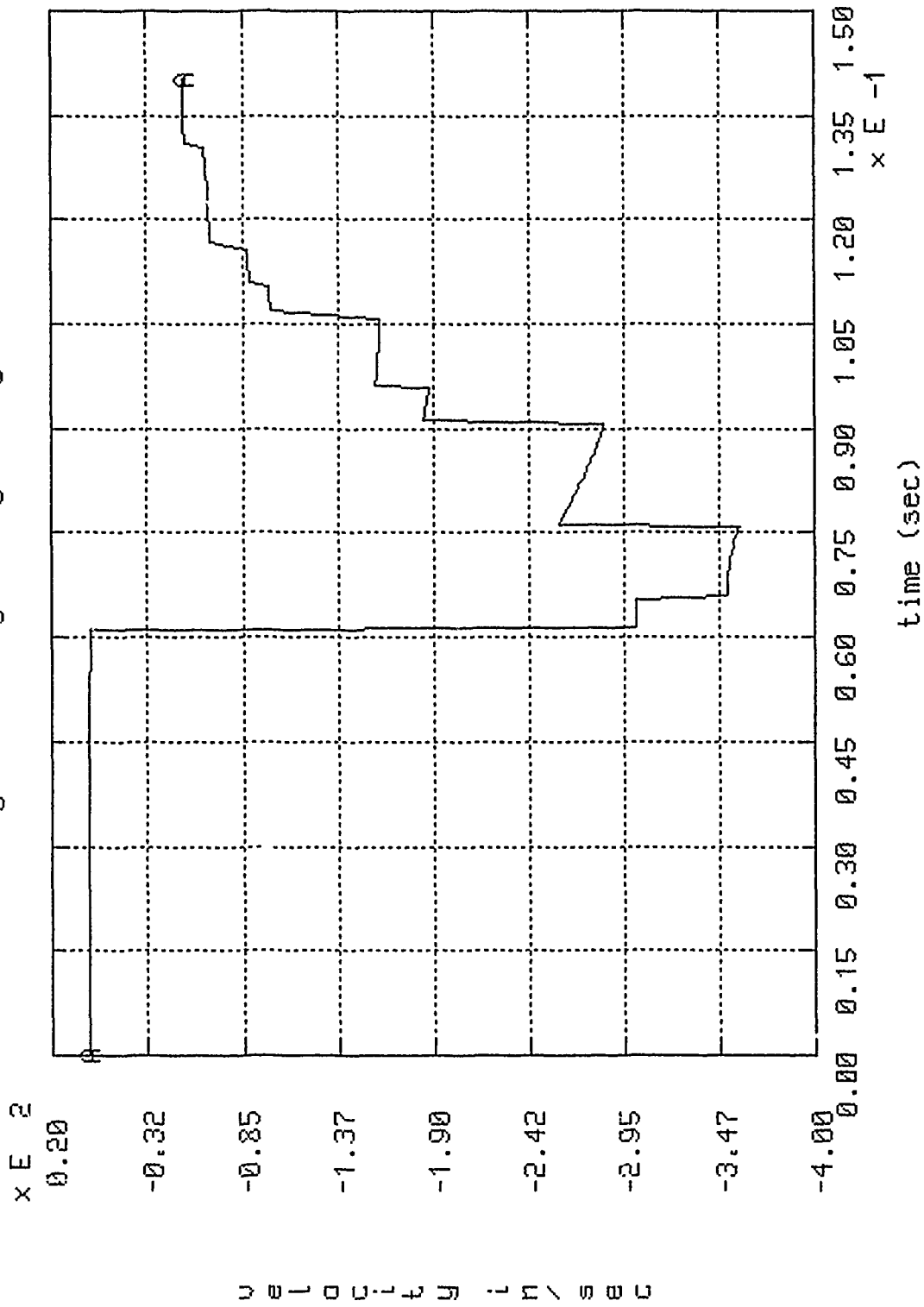
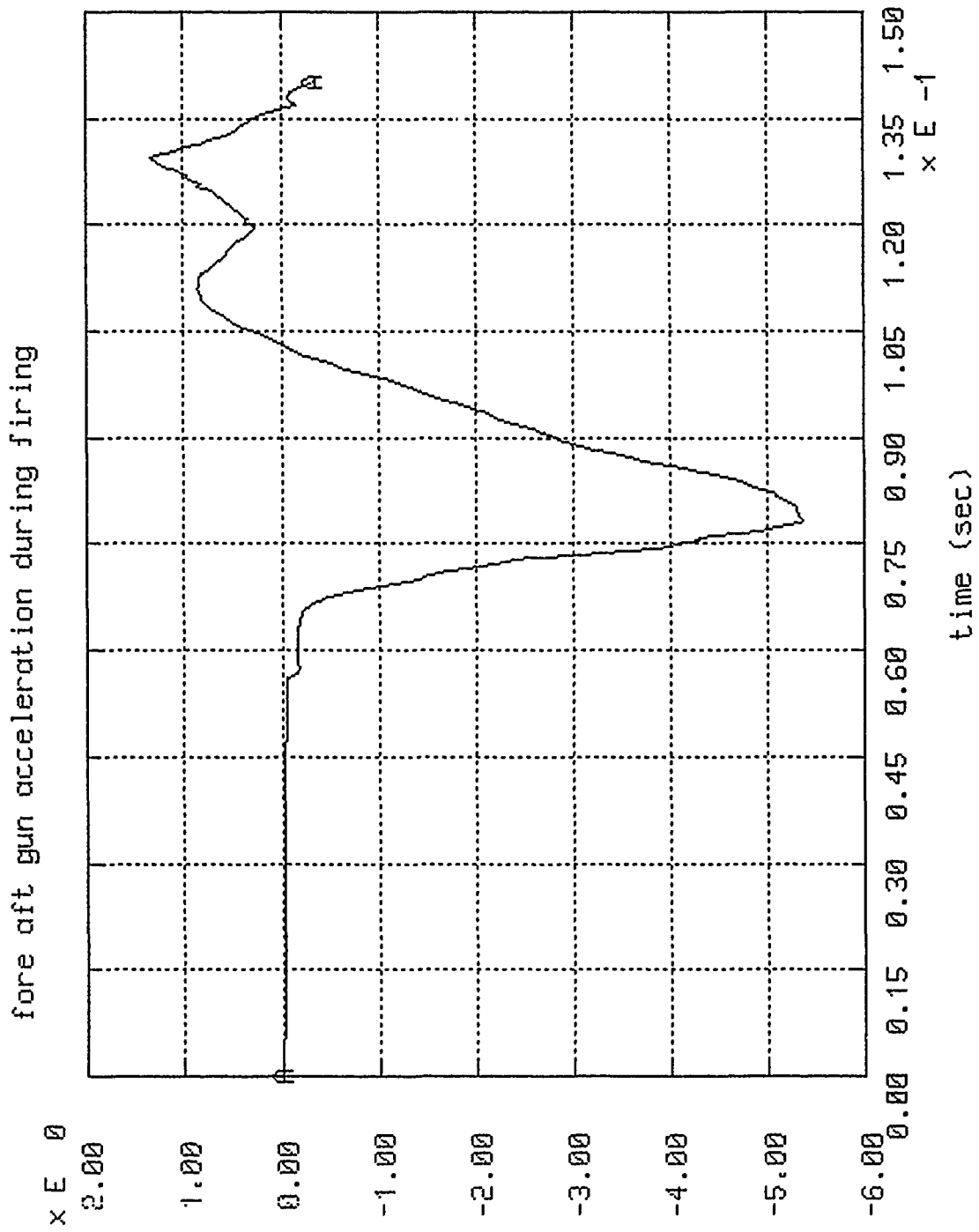

FIG 114
FORE - AFT GUN VELOCITY DURING FIRING



a c c e l e r a t i o n

FIG 115
FORE - AFT GUN ACCELERATION DURING FIRING

0 0 0 0 1 0 0 0 0

chassis acceleration during firing c long. b vertical

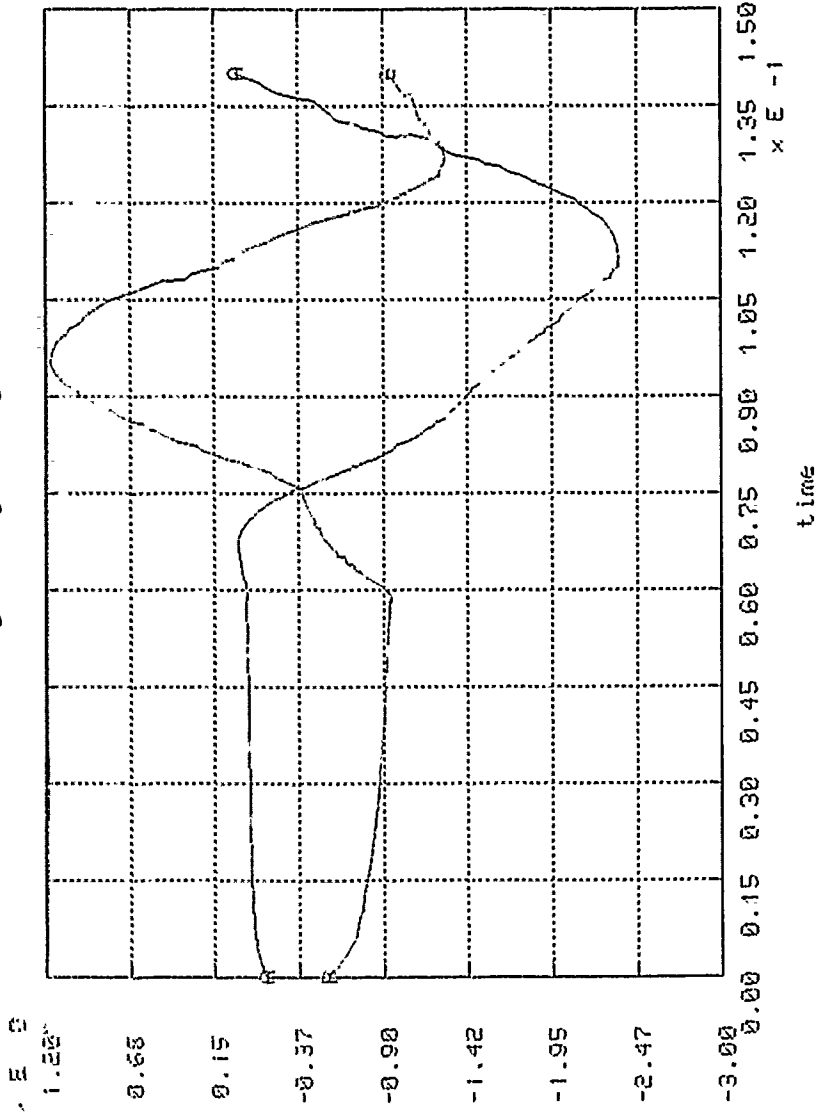

FIG 116
CHASSIS ACCELERATION DURING FIRING

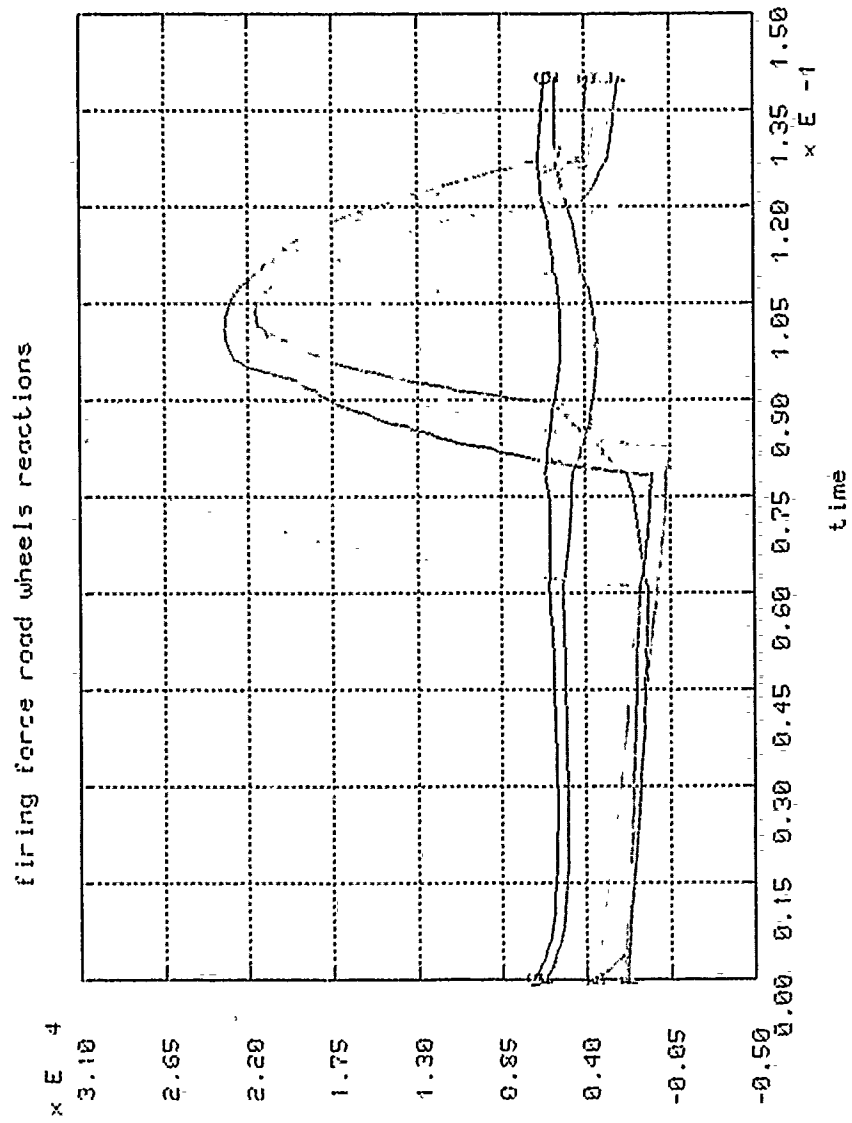

FIG 117
ROADWHEELS REACTIONS DUE TO FIRING FORCE

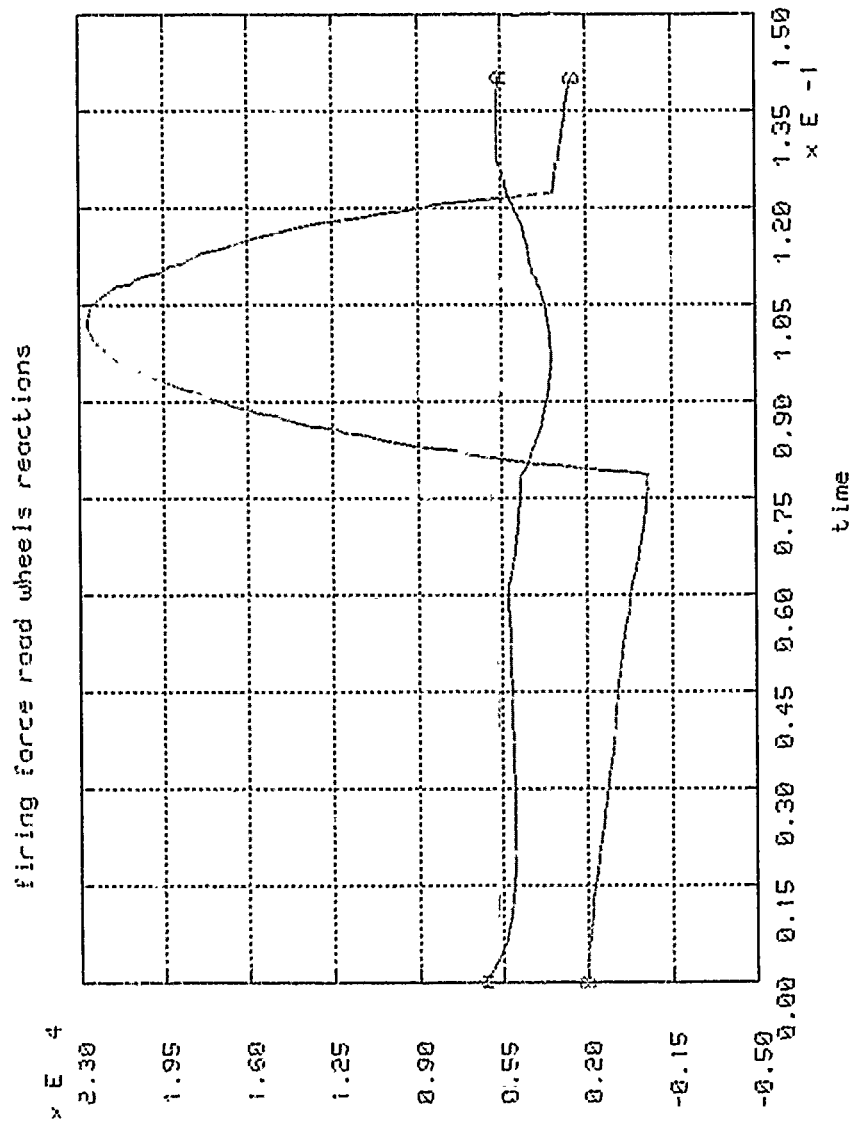

FIG 118
FIRING FORCE ROADWHEELS REACTIONS (1,4, and 7)

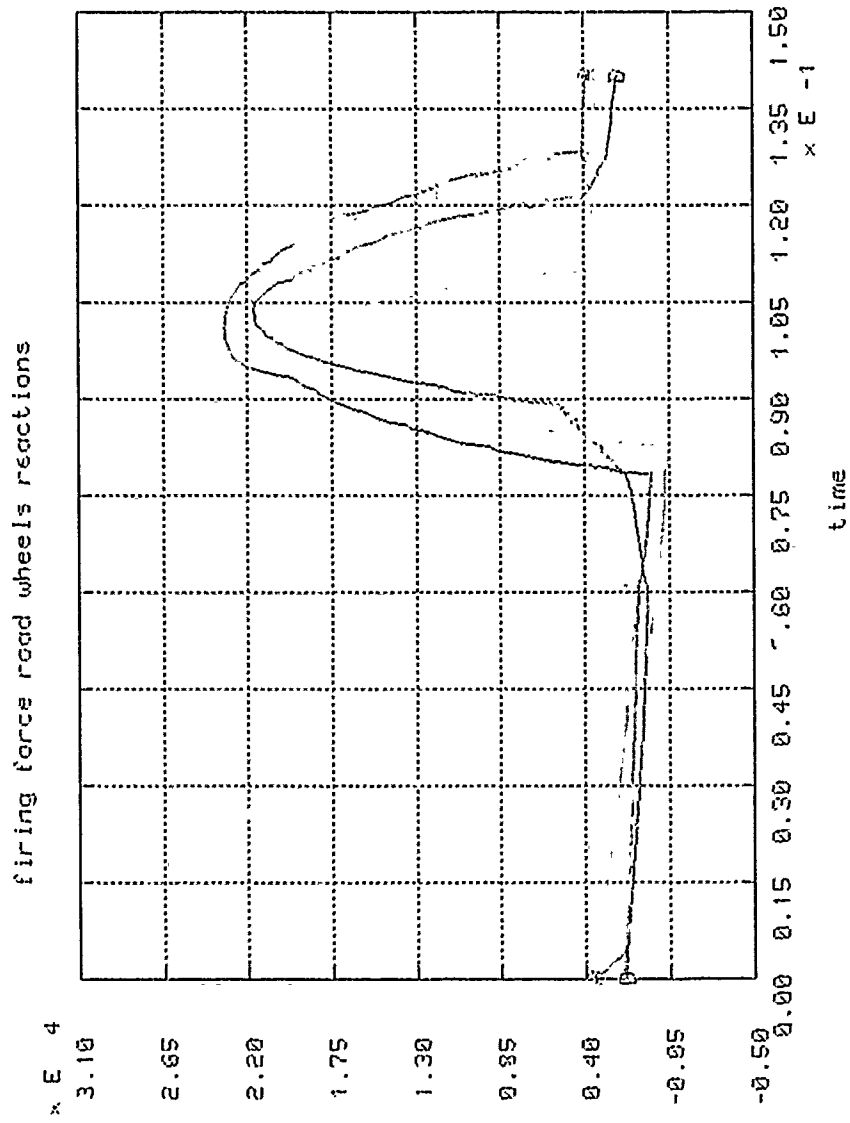

FIG 119
 FIRING FORCE ROADWHEELS REACTIONS (2,3,5, and 6)



RDE CENTER - TACOM



CATTB FORE-AFT DISPLACEMENT - L.W. GUN & 120MM GUN FIRE
x E 0

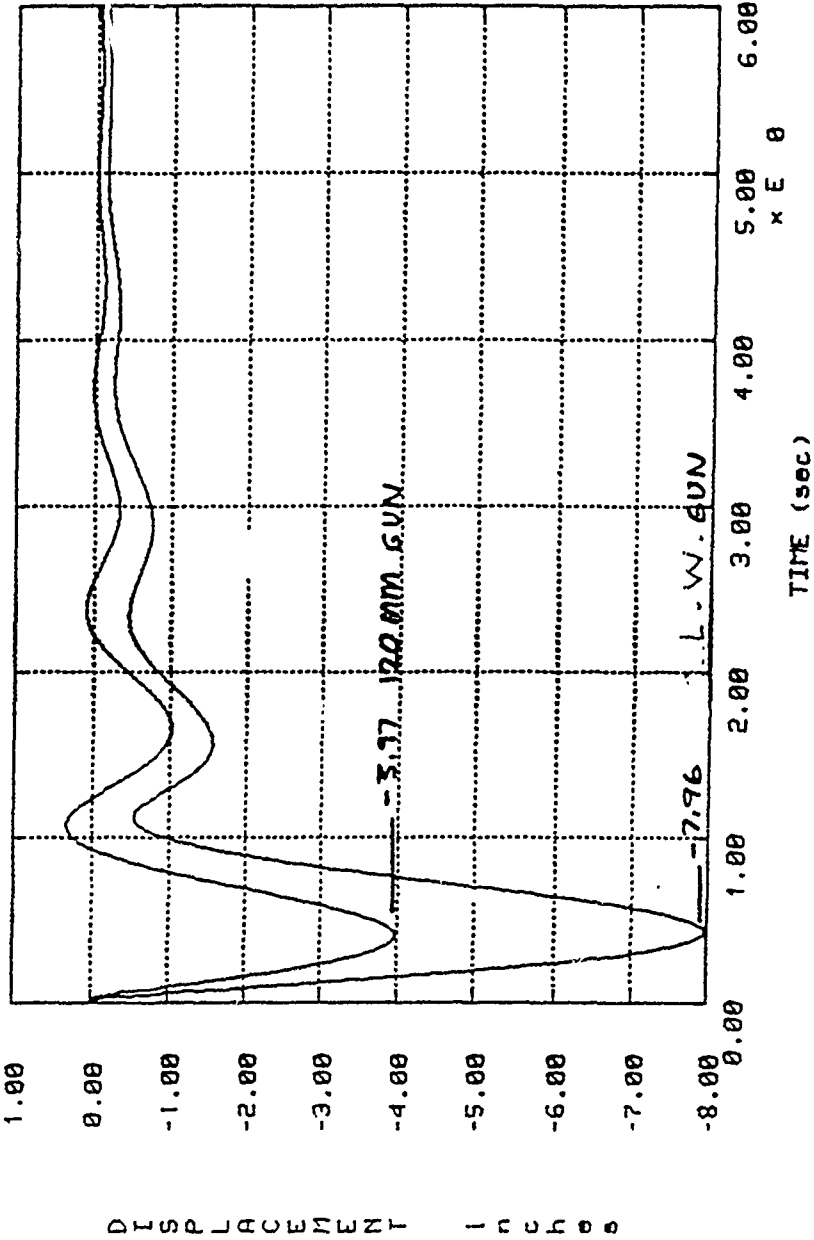

FIG 120
FORE - AFT DISPLACEMENT FOR LW GUN AND 120 MM GUN

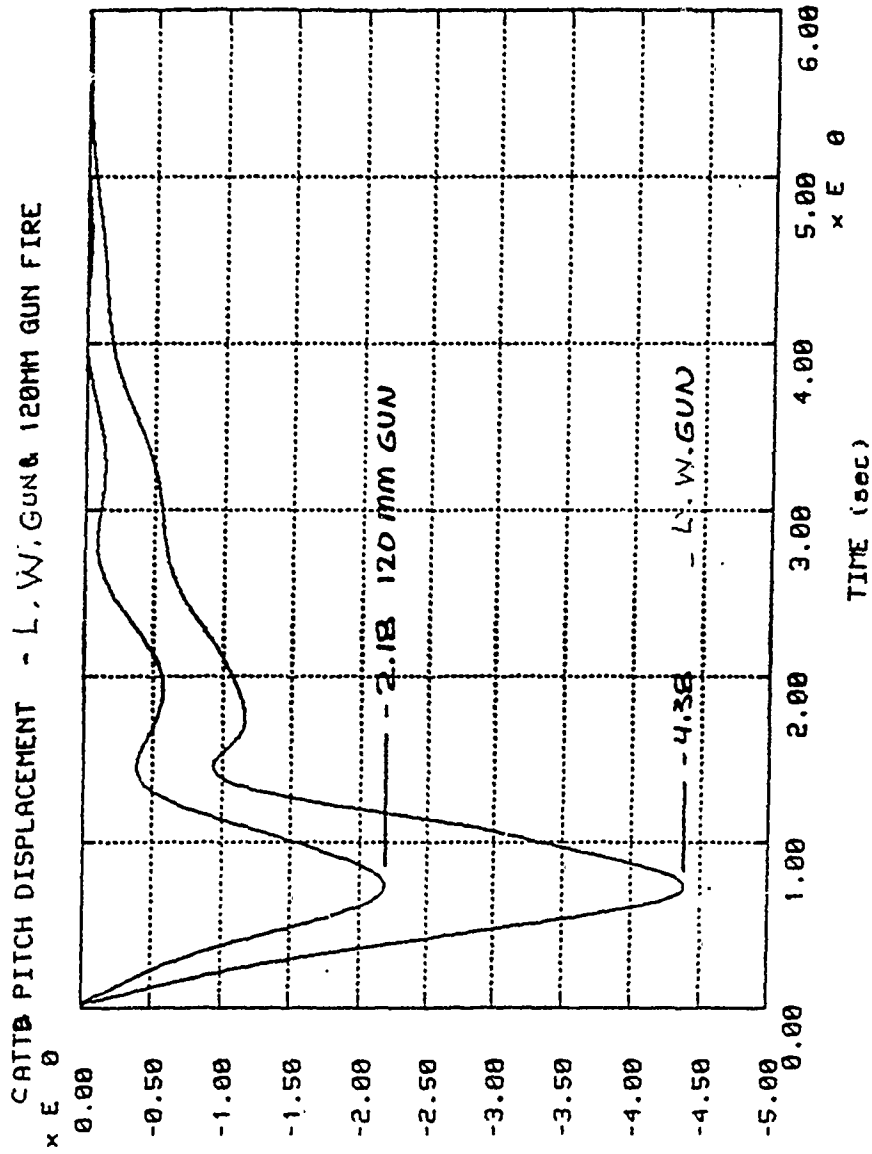
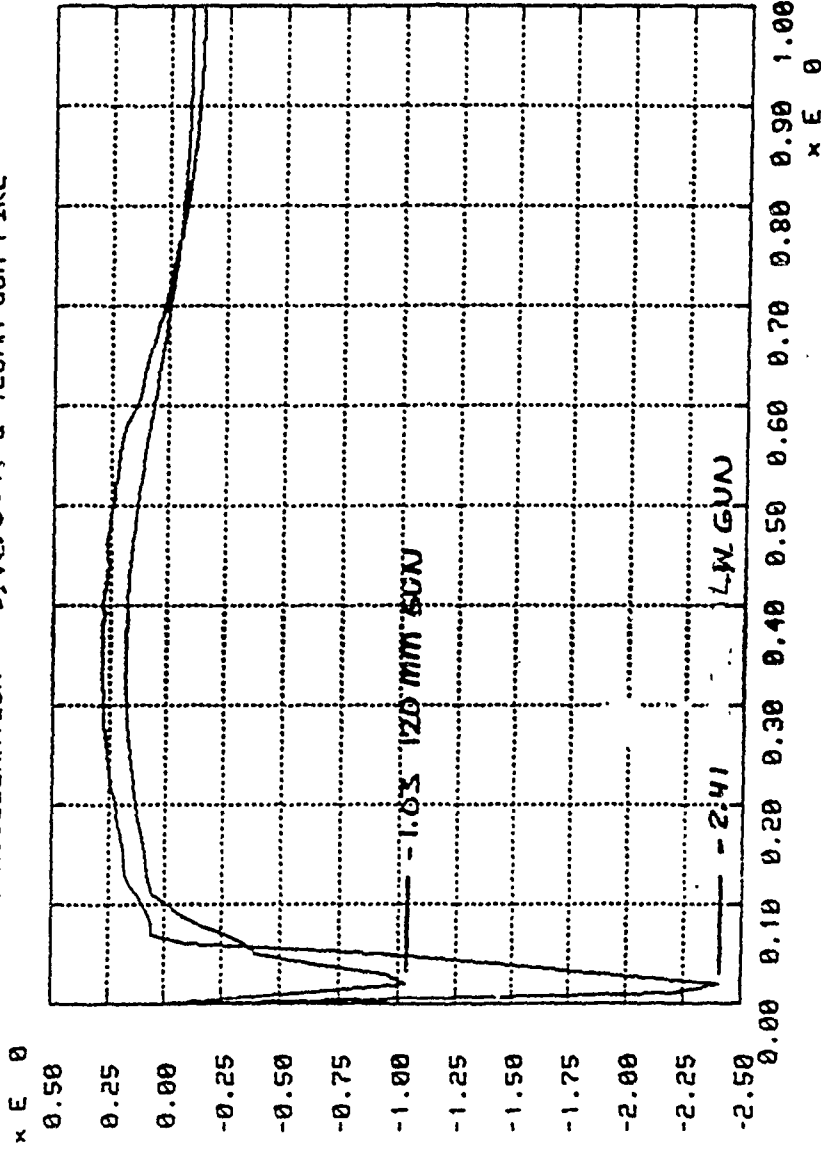

FIG 121
PITCH DISPLACEMENT FOR LW GUN AND 120 MM GUN



CATTB FORE-AFT ACCELERATION - L.W. GUN & 120MM GUN FIRE



TIME (SEC)

REPORT INTERVAL = 0.01 SECONDS

FIG 122
FORE - AFT ACCELERATION FOR LW GUN AND 120 MM GUN

4.4 Dynamic Finite Element Stress Analysis:

In the previous finite element analysis section (4.2), the dynamic nature of the load (terrain and gun firing) was not investigated. To complete this study, the dynamic effects of this load on the CATTB Chassis must be evaluated. Dynamic analysis software NISA (Numerically Integrated System Analysis) was utilized. To have access to this software, it was necessary to transfer the CATTB FEM model to the Cray Supercomputer. To accomplish this, the CATTB FEM model, which was built using IRM Software on the Intergraph CAD System, had to be transferred to the prime computer and had to be translated into PATRAN and then into NISA. Then it had to be brought back to the Cray for analysis. This tedious procedure proved to be useful, due to the amazing speed at which the analysis could be performed on the Cray supercomputer.

4.4.1 Dynamic Effects of Terrain Forces

In the dynamic analysis of CATTB (section 4.3), the forces in the roadwheel attachment points were found to be time dependent and were maximum at roadwheels 3 and 4, as shown in Fig (117). In the static FEM analysis (section 4.2), these forces were calculated as support reactions and were maximum at roadwheels 1 and 7 (Fig. 124). To reconcile between the two results, the roadwheel attachment points had to be allowed to have relative movement to each other so that the corrected support reactions in the Static FEM analysis would equal those found in the dynamic analysis.

The relative movement for all roadwheels attachment points created additional stress in the chassis which had to be added to static FEM analysis stresses (Fig 125 shows the chassis stresses due to vertical movement of 0.10 inches at first left roadwheel). To maximize the effects of Terrain Dynamic Forces, the forces in the roadarms attachment points obtained from DADS analysis were chosen in such a way that they caused maximum bending in the chassis. Two cases for these terrain forces were considered; the first case yielded maximum bending at first roadwheel, whereas the second assumed maximum bending at the fourth roadwheel. The dynamic effects of the terrain forces could easily be visualized by comparing the results of the static FEM analysis (Fig 123) and the results of Dynamic FEM analysis (Fig 126 & 127)

Total VON Mises stresses for the two terrain cases are shown in Fig (128 & 129) and Fig (130 & 131) respectively.

4.4.2 Dynamic Effects of Firing Load:

In the previous FEM analysis (section 3.2) the firing load was considered static. To account for its dynamic nature, a dynamic load factor of 2 was used as a multiplier. To study the dynamic nature of the gun firing load, a transient dynamic analysis was required. The first step in this type of analysis was the modal analysis or EIGEN VALUE and EIGEN VECTOR analysis (natural frequency and vibrated shape).

This was accomplished, and the results were satisfactory (Table 6 - 8). However, the binary files, which will be used in the transient dynamic analysis, could not be properly translated from analysis results. Further studies in this area can be resumed when future software revision enables correct translation of the binary files.

CATTB STRESS ANALYSIS FOR STATIC FIRING LOAD

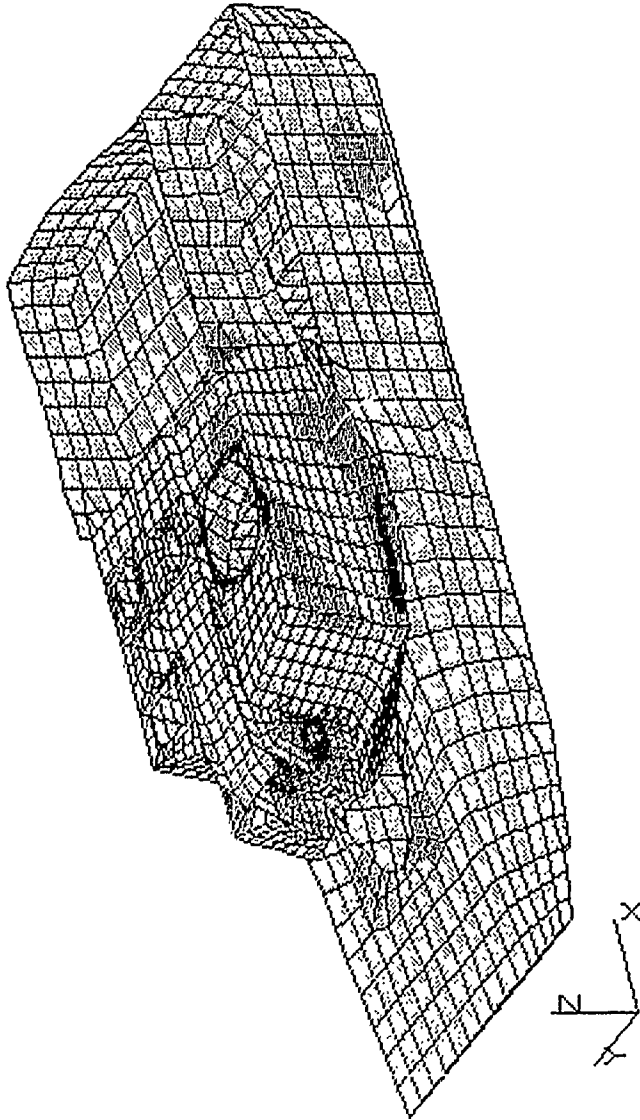

4.10+04	
3.43+04	P
2.76+04	C
2.10+04	D
1.43+04	
7.62+03	
9.53+02	F
-5.72+03	G
-1.24+04	H
-1.91+04	I
-2.57+04	J
-3.24+04	
-3.91+04	L
-4.57+04	M
-5.24+04	N
-5.91+04	O

STRESS (PSI)

FIG 123
CATTB STRESS ANALYSIS FOR STATIC FIRING LOAD

CATTB ROAD WHEELS REACTIONS UNDER STATIC FIRING LOAD

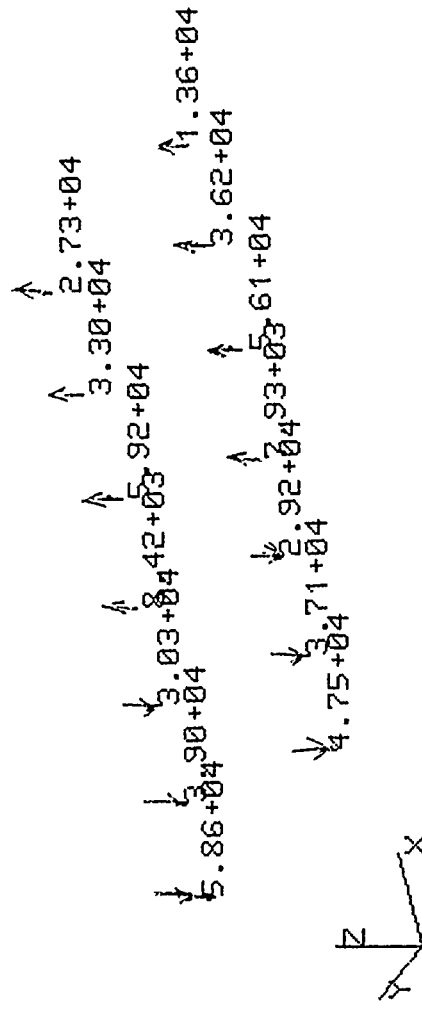
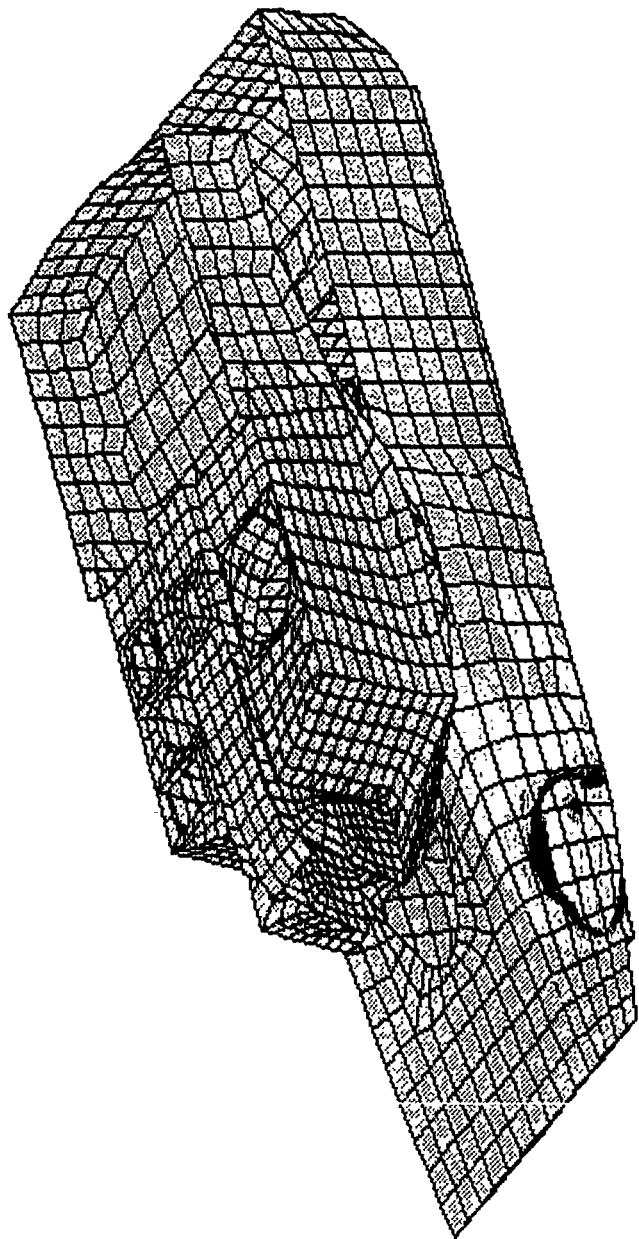
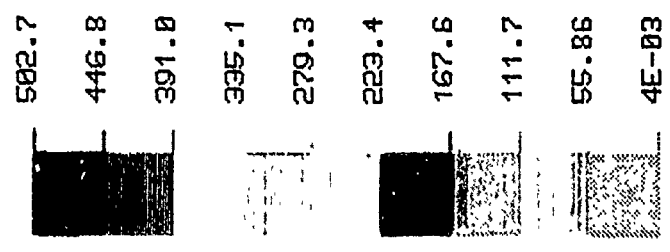

FIG 124
CATTB ROADWHEELS REACTIONS UNDER STATIC FIRING LOAD

E.M.R.C.- DISPLAY II POST-PROCESSOR VERSION 89.0 Dec/14/89

STRESS CONTOURS
VDN-MISES STRESS
VIEW : 4.47E-01
RANGE : 5.83E+04

Legend :



EMRC-NISA-DISPLAY

RX= -60
RY= 0
RZ= 30

CATTB NUIETRAL FILE FROM PATRAN 7 NOV 89
LOAD CASE NUMBER 1, BOTTOM LAYER



FIG 125
CATTB STRESSES DUE TO 0.16 IN VERTICAL MOVEMENT AT FIRST ROADWHEEL

CATTB STRESS ANALYSIS FOR DYNAMIC FIRING LOAD

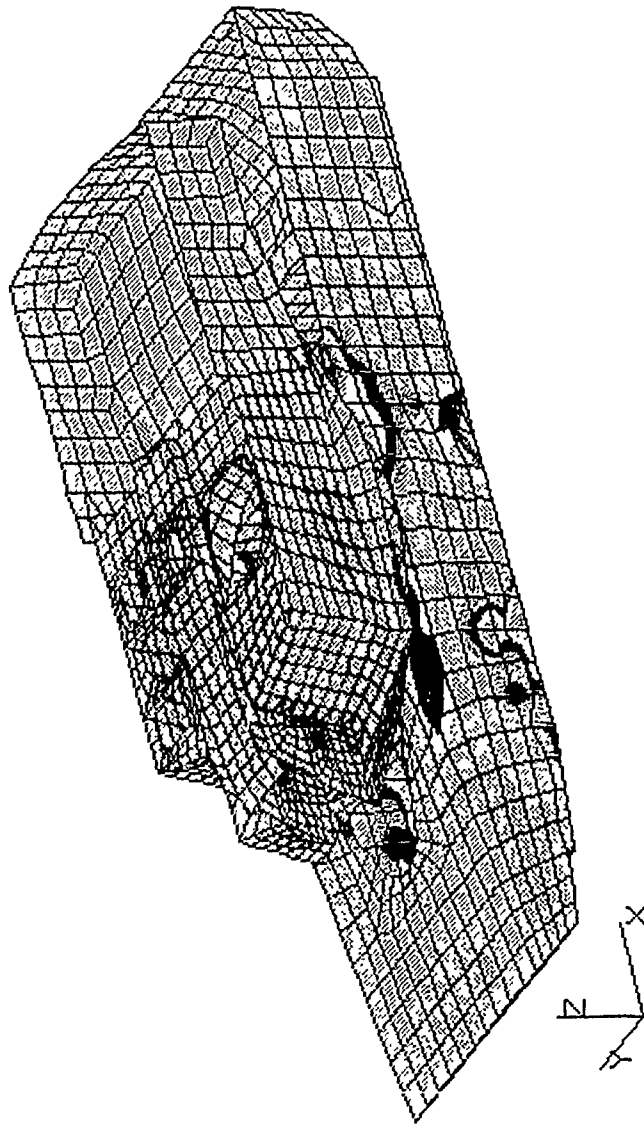

5.01+04	4.29+04	3.57+04	2.84+04	2.12+04	1.40+04	6.80+03	-4.13+02	-7.63+03	-1.48+04	-2.21+04	-2.93+04	-3.65+04	-4.37+04	-5.09+04	-5.81+04
	B	C	D			F	G	H	I	J			M	N	O

BEND STR(PST)

FIG 126
CATTB STRESSES FOR DYNAMIC FIRING LOAD

E.M.R.C.- DISPLAY II POST-PROCESSOR VERSION 89.0 Dec/14/89

STRESS CONTOURS
VON-MISES STRESS
VIEW : 1.70E+01
RANGE : 6.43E+04

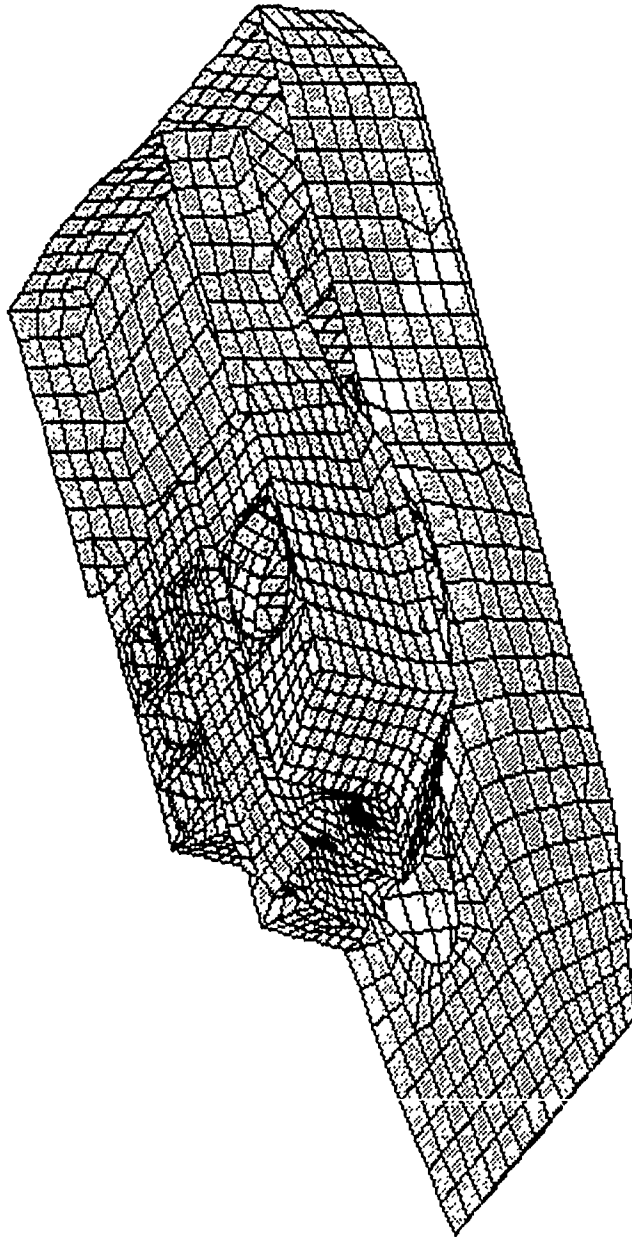

643.4

571.9

500.4

429.0

357.5

286.0

214.6

143.1

71.64

0.1697

EMRC-NISA/DISPLAY

RX= -60
RY= 0
RZ= 30

A small diagram showing a 3D coordinate system with three axes: X, Y, and Z. The X-axis is horizontal, the Y-axis is vertical, and the Z-axis is diagonal. The origin is at the center of the axes.

CATTB NUETRAL FILE FROM PATRAN 7 NOV 89

LOAD CASE NUMBER 16, BOTTOM LAYER

FIG 127
CATTB STRESSES FOR DYNAMIC FIRING LOAD

E.M.R.C.- DISPLAY II POST-PROCESSOR VERSION 89.0 Dec/20/89

STRESS CONTOURS
MAX. SHEAR STRESS
VIEW : 2.70E+00
RANGE : 3.65E+04

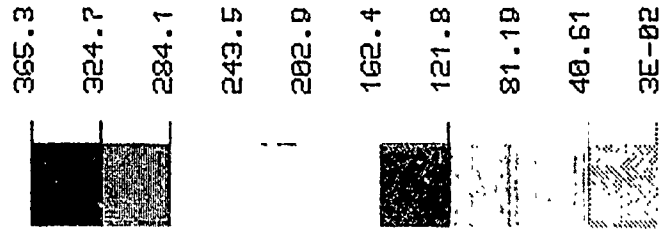
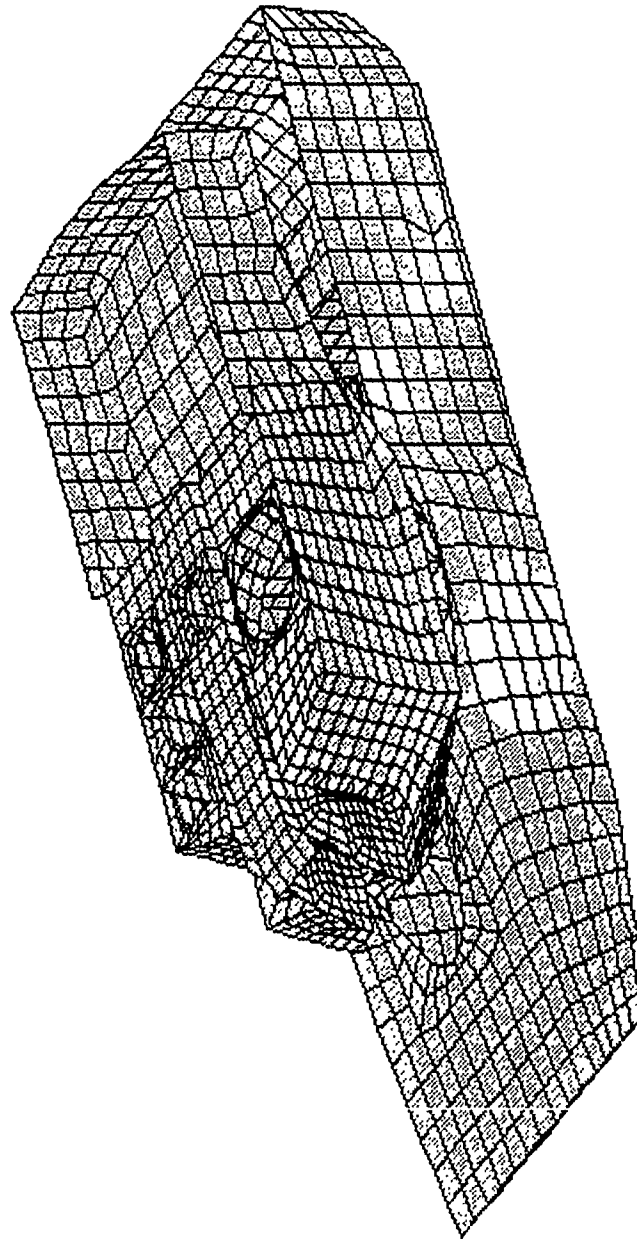

EMRC-NISA-DISPLAY

RX= -60
RY= 0
RZ= 30



8 NUETRAL FILE FROM PATRAN 7 NOV 89

TERRAIN EFFECET CASE 1 + FIRING

FIG 128
CATTB STRESSES FOR FIRING LOAD AND TERRAIN LOAD
(CASE 1)

E.M.R.C.- DISPLAY II POST-PROCESSOR VERSION 89.0 Jan/ 4/90

STRESS CONTOURS
 VON-MISES STRESS
 VIEW : 5.06E+01
 RANGE : 1.89E+04

0.0000 1.89E+04

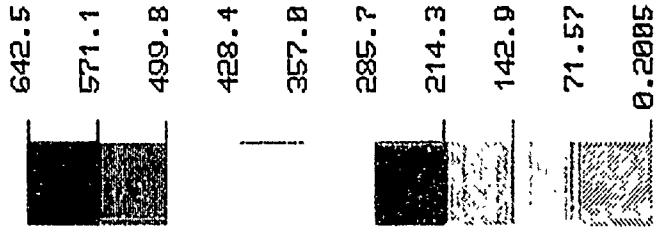
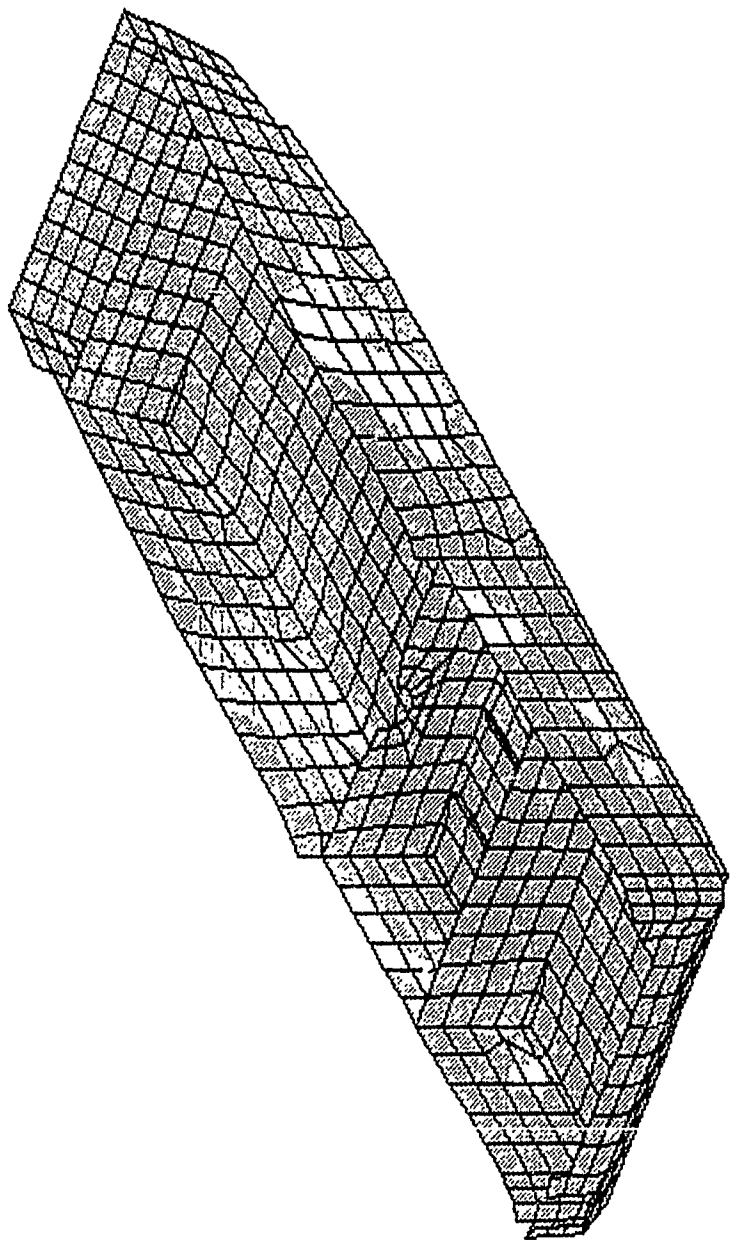

EMRC-NISA-DISPLAY

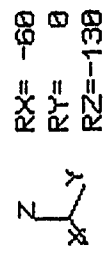

CATTB NEUTRAL FILE FROM PATRAN 7 NOV 89
 TERRAIN EFFECT CASE 1 + FIRING

FIG 129
 CATTB STRESSES FOR FIRING LOAD AND TERRAIN LOAD
 (CASE 1)

E.M.R.C.- DISPLAY II POST-PROCESSOR VERSION 89.8 Dec/14/89

STRESS CONTOURS
VON-MISES STRESS
VIEW : 2.68E+01
RANGE : 6.49E+04

Legend (1.0E2)

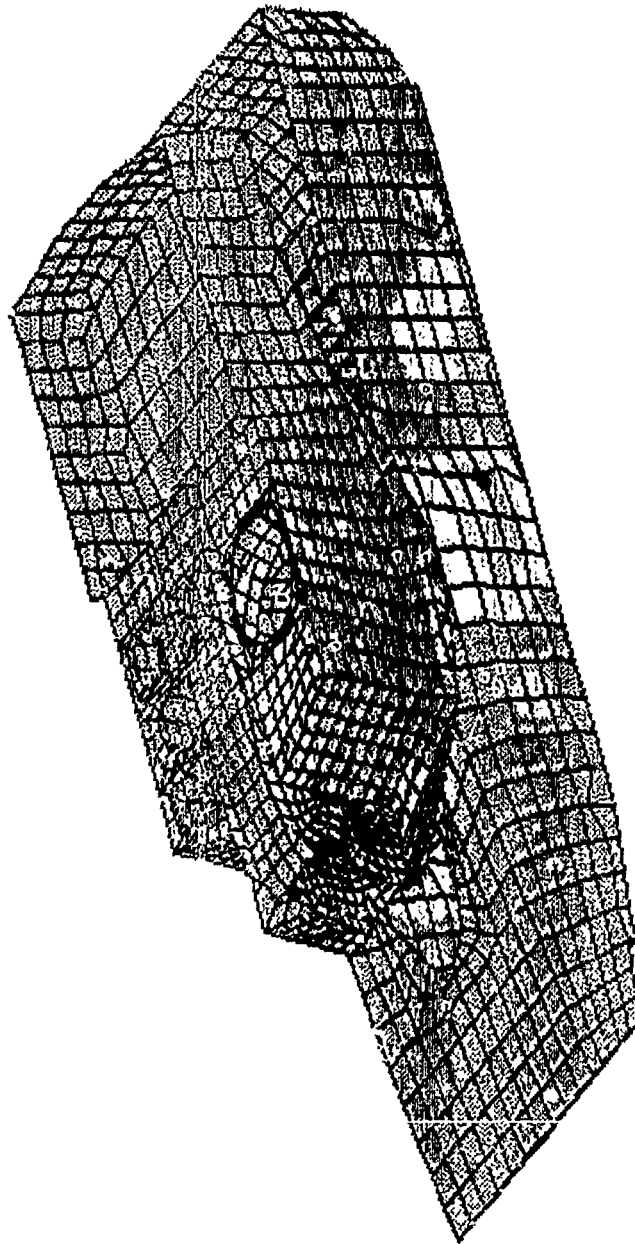
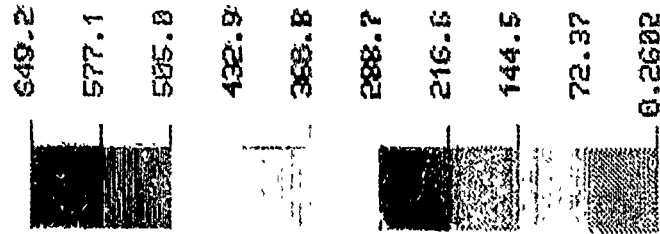

EMRC-NISA-DISPLA

RX= -68
RY= 0
RZ= 30

CATTB NUETRAL FILE FROM PATRAN 7 NOV 89
TERRAIN EFFECTS CASE 2 + FIRING

FIG 130
CATTB STRESSES FOR FIRING LOAD AND TERRAIN LOAD
(CASE 2)

E.M.R.C.- DISPLAY II POST-PROCESSOR VERSION 89.0 Jan/ 4/90

STRESS CONTOURS
VDN-MISES STRESS
VIEW : 4.30E+01
RANGE : 3.62E+04

0.0000 1.0000

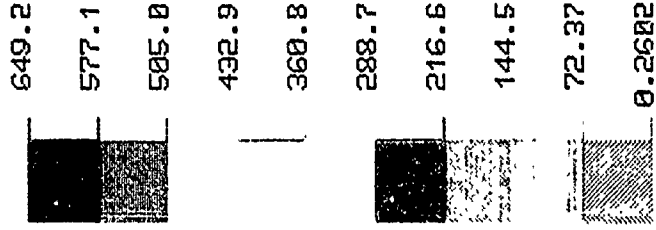
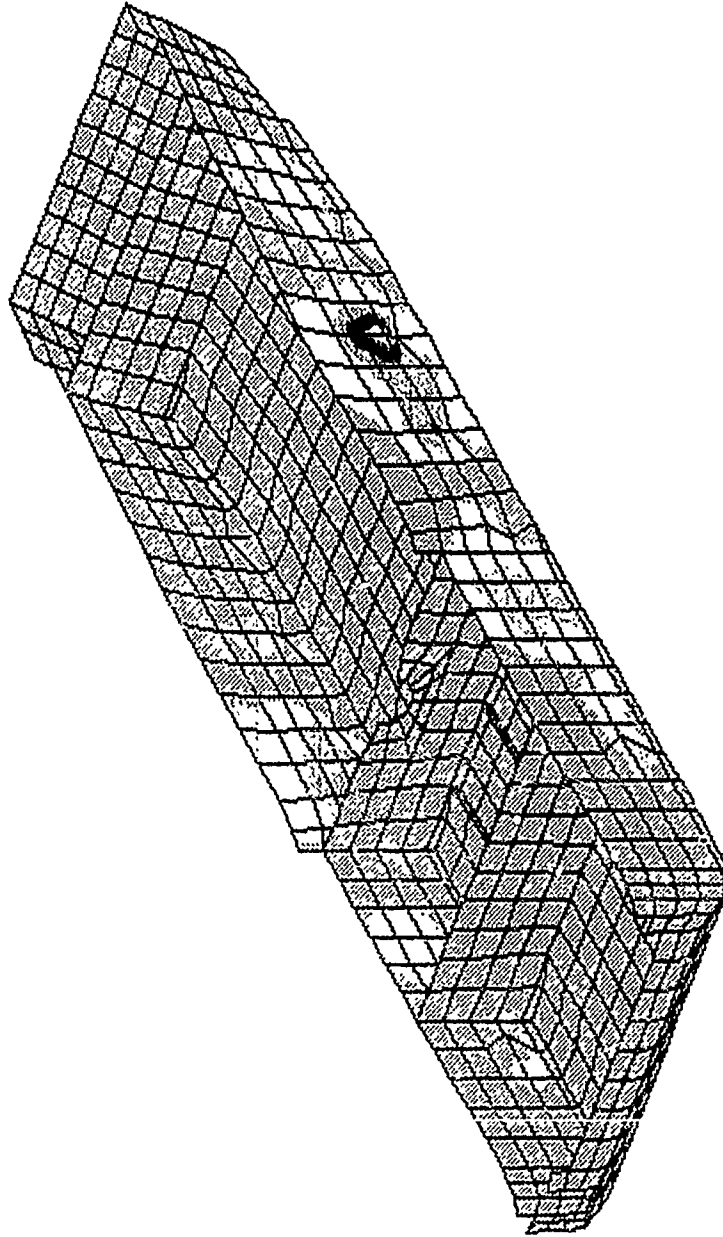

EMRC-NISA-DISPLAY

RX=-60
RY= 0
RZ=-130

CATTB NUIETRAL FILE FROM PATRAN 7 NOV 89
TERRAIN EFFECTS CASE 2 + FIRING

FIG 131
CATTB STRESSES FOR FIRING LOAD AND TERRAIN LOAD
(CASE 2)

***** EIGENVALUE ANALYSIS *****

MODE NUMBER	FREQUENCY (RAD/SEC)	FREQUENCY (CYCLES/SEC)	PERIOD (SEC)	TOLERANCE
1	1.345904E+02	2.142072E+01	4.668377E-02	3.521785E-12
2	1.422180E+02	2.263470E+01	4.417995E-02	6.056184E-11
3	1.695692E+02	2.698777E+01	3.705382E-02	2.586711E-09
4	2.069485E+02	3.293687E+01	3.036111E-02	1.109454E-06
5	2.260021E+02	3.611259E+01	2.769117E-02	8.254605E-06

TABLE 6
CATTB EIGEN VALUE ANALYSIS RESULTS - FREQUENCY

**** REACTION FORCES AND MOMENTS AT NODES **

MODE NO. 1

NODE	FX	FY	FZ	MX
1732	0.00000E+00	0.00000E+00	-4.18480E+03	0.00000E+00
1733	0.00000E+00	0.00000E+00	5.00486E+03	0.00000E+00
1738	0.00000E+00	0.00000E+00	5.58802E+01	0.00000E+00
1739	0.00000E+00	0.00000E+00	-2.10084E+03	0.00000E+00
1744	0.00000E+00	0.00000E+00	-2.81085E+03	0.00000E+00
1745	0.00000E+00	0.00000E+00	2.59796E+03	0.00000E+00
1750	0.00000E+00	0.00000E+00	-2.40608E+04	0.00000E+00
1780	0.00000E+00	0.00000E+00	-8.88090E+03	0.00000E+00
1837	0.00000E+00	0.00000E+00	2.73841E+04	0.00000E+00

TABLE 7
CATTB EIGEN VALUE ANALYSIS RESULTS - REACTION FORCES



*** E M R C N I S A *** MODE NO. 5
 DEC/29/1989 9:23:35 --- VERSION 88.7 (08/11/88)

EIGENVALUES OF CATTB MODEL

*** AVERAGE NODAL STRESSES ***

NODE SYZ	SX SZX	SY	SZ	SXY
1 1.22055E+02	9.20810E+02 -2.50339E+01	0.00000E+00	3.07728E+01	3.05507E+0
2 -4.07447E+01	-7.32581E+01 6.51869E+02	6.38854E+00	-3.58670E+02	4.53680E+0
3 1.93401E+02	4.95336E+02 3.80859E+02	7.50168E+01	-1.07588E+02	-3.86280E-0

TABLE 8
CATTB EIGEN VALUE ANALYSIS RESULTS -- NODAL STRESSES

5. Conclusions:

5.1 Turret Design - The new locations of the turret side-plates significantly increased turret strength and kept stress at its current level. Whereas locating these side-plates in similar fashion to the M1 Turret could have resulted in higher stresses and deformations, due to the reduced turret strength.

5.2 Trunnion Design - It is recommended that the size of the bolts in the gun-mounting block not exceed 3/8" to minimize the loss of the resisting area, and the pretension load in these bolts should not exceed 6000 - 8000 lb/bolts, because it will create additional stress in the trunnion in the range of (9,000 - 12,000) PSI.

5.3 Casting - Hull casting reinforcement is needed. It can be achieved by extending the casting plate to the chassis side-plates and should not be compromised.

5.4 Power Pack Mounting - From stress analysis results, it is clear that the power pack will not cause excessive stress in the hull floor plate. But the current analysis did not consider the rigidity of the power-pack, which is more than enough to transfer its weight to hull side-plates. In this case, the floor mounting will not only be ineffective but it might be a nuisance, since the floor plates are not stiff, and it might transmit unnecessary vibration to the power-pack components. For this reason, it is better to utilize side-plate mounting for all major CATTB components, such as the auto-loader and the power-pack. This will allow effective optimization for floor plates.

5.5 Design Optimization - It is recommended to optimize the design (when optimization software becomes available) to reduce the percentage of CATTB basic structure weight (currently it is about 30%).

6.2 Recommendations:

This study was conducted under extraordinarily difficult circumstances due to the relatively recent software utilized (EMS, IGDS, IRM, IFEM, PATRAN, NISA), which is under continuous revision, not to mention the operating difficulties encountered on the VAX computer. All this combined complicated and hindered the interface between various design stages, and it did not allow this study to be concluded to the extent intended. Therefore, the following recommendations are directed toward improving the operating system.

6.1 It is beneficial to obtain a translator from intergraph FEM software (IFEM) to analysis software ABAQUS. This translator must provide complete translation for FEM Model (Load, Material and Element Properties etc.) and it must be available in the Cray supercomputer.

6.2 It will be beneficial to obtain a translator from future analysis software ABAQUS to DADS software. This will make building a DADS model for dynamic analysis much easier, and it will allow an iteration process between Dynamic Analysis and Finite Element Analysis, which is essential for design optimization.

6.3 It will be beneficial to obtain optimization software to work closely with analysis software ABAQUS.

6.4 The implementation of the various software and hardware revisions should be made coincidentally and not more than once a year to allow smoother transition between design stages of long project.

6.5 DADS program (Tracked Super Element) should be enhanced so that it can handle hydroneumatic suspensions and DADS software must be debugged thoroughly.

TURRET MASS PROPERTIES BASIC STRUCTURE

\$

SUMMARY OF MASS PROPERTIES

Object number: 0
 Object description: Manipulations
 Mass units - MU; Length units - inch
 Density 0.283001
 Axes orientation General
 Reference point [0, 0, 0]
 Axes Orientation wrt global co-ordinate system:
 1, 0, 0
 0, 1, 0
 0, 0, 1

Centroid [56.4641, -0.18296, 21.2038]
 Volume 60315 inch**3
 Mass 17069.2 MU
 Moment about X axis 2.80978e+07 MU inch**2
 Moment about Y axis 1.10486e+08 MU inch**2
 Moment about Z axis 1.17457e+08 MU inch**2
 Product moment XY -168532 MU inch**2
 Product moment YZ -36974.9 MU inch**2
 Product moment ZX 2.25278e+07 MU inch**2
 Surface area 86514.3 inch**2

Radii of gyration:
 X axis 40.5723 inch
 Y axis 80.454 inch
 Z axis 82.953 inch

TURRET MASS PROPERTIES SIDE ARMOR

\$

SUMMARY OF MASS PROPERTIES

Object number: 0
 Object description: Manipulations
 Mass units - MU; Length units - inch
 Density 0.0949999
 Axes orientation General
 Reference point [0, 0, 0]
 Axes Orientation wrt global co-ordinate system:
 1, 0, 0
 0, 1, 0
 0, 0, 1

Centroid [-24.9139, -0.657351, 18.5299]
 Volume 183035 inch**3
 Mass 17388.3 MU
 Moment about X axis 4.28329e+07 MU inch**2
 Moment about Y axis 3.65686e+07 MU inch**2
 Moment about Z axis 6.47632e+07 MU inch**2
 Product moment XY 66268.3 MU inch**2
 Product moment YZ -292055 MU inch**2
 Product moment ZX -7.48568e+06 MU inch**2
 Surface area 37490.6 inch**2

Radii of gyration:
 X axis 49.6318 inch
 Y axis 45.8591 inch
 Z axis 61.0289 inch

\$

TURRET MASS PROPERTIES TOP ARMOR

\$

SUMMARY OF MASS PROPERTIES

Object number: 0
 Object description: Manipulations
 Mass units - MU; Length units - inch
 Density 0.1215
 Axes orientation General
 Reference point [0, 0, 0]
 Axes Orientation wrt global co-ordinate system:
 1, 0, 0
 0, 1, 0
 0, 0, 1

Centroid [14.1535, 0.253762, 42.0144]
 Volume 23887.1 inch**3
 Mass 2902.29 MU
 Moment about X axis 6.85467e+06 MU inch**2
 Moment about Y axis 7.31564e+06 MU inch**2
 Moment about Z axis 4.49644e+06 MU inch**2
 Product moment XY 54887.8 MU inch**2
 Product moment YZ 26948.9 MU inch**2
 Product moment ZX 1.70518e+06 MU inch**2
 Surface area 19227.1 inch**2

Radii of gyration:
 X axis 48.5985 inch
 Y axis 50.206 inch
 Z axis 39.3608 inch

TURRET MASS PROPERTIES SPALL LINER

\$.

SUMMARY OF MASS PROPERTIES

Object number: 0
 Object description: Manipulations
 Mass units - MU; Length units - inch
 Density 0.04
 Axes orientation General
 Reference point [0, 0, 0]
 Axes Orientation wrt global co-ordinate system:
 1, 0, 0
 0, 1, 0
 0, 0, 1

Centroid [18, 0.276264, 26.154]
 Volume 31218.5 inch**3
 Mass 1248.74 MU
 Moment about X axis 2.18745e+06 MU inch**2
 Moment about Y axis 2.43883e+06 MU inch**2
 Moment about Z axis 2.59283e+06 MU inch**2
 Product moment XY 15404.8 MU inch**2
 Product moment YZ 12226.1 MU inch**2
 Product moment ZX 553304 MU inch**2
 Surface area 75126.3 inch**2

Radii of gyration:
 X axis 41.8537 inch
 Y axis 44.1931 inch
 Z axis 45.567 inch

TURRET MASS PROPERTIES BASKET

SUMMARY OF MASS PROPERTIES

Object number: 0
 Object description: Manipulations
 Mass units - MU; Length units - inch
 Density 0.283
 Axes orientation General
 Reference point [0, 0, 35.5]
 Axes Orientation wrt global co-ordinate system:

1, 0, 0
 0, 1, 0
 0, 0, 1

Centroid [-2.64185, 0.716254, 2.90991]
 Volume 2939.33 inch**3
 Mass 831.83 MU
 Moment about X axis 1.34007e+06 MU inch**2
 Moment about Y axis 1.29398e+06 MU inch**2
 Moment about Z axis 777900 MU inch**2
 Product moment XY 31721.2 MU inch**2
 Product moment YZ -14713.8 MU inch**2
 Product moment ZX 52043.6 MU inch**2
 Surface area 13584.6 inch**2

Radii of gyration:
 X axis 40.1372 inch
 Y axis 39.4409 inch
 Z axis 30.5805 inch

\$

TURRET MASS PROPERTIES GEAR BOX

\$ cat mogearbox

SUMMARY OF MASS PROPERTIES

Object number: 0
 Object description: Manipulations
 Mass units - MU: Length units - inch
 Density 0.283
 Axes orientation General
 Reference point [0, 0, 0]
 Axes Orientation wrt global co-ordinate system:

X: 0, 0
 Y: 1, 0
 Z: 0, 1

Centroid [0.88646, 4.32289, -6.25875]

Volume 2013.16 inch**3

Mass 569.725 MU

Moment about X axis 687.9 MU inch**2

Moment about Y axis 57815.9 MU inch**2

Moment about Z axis 42241.6 MU inch**2

Product moment XY 14388.3 MU inch**2

Product moment YZ -21268.6 MU inch**2

Product moment ZX -19248.7 MU inch**2

Surface area 1971.77 inch**2

Radii of gyration:
 X axis 18.8266 inch
 Y axis 18.8737 inch
 Z axis 8.81219 inch

TURRET MASS PROPERTIES AUTOMATIC LOADER

\$ cat mol loader

SUMMARY OF MASS PROPERTIES

Object number: 0
 Object description: Manipulations
 Mass units: MU, Length units: inch
 Density: 0.035
 Axes orientation: General
 Reference point: [0, 0, 0]
 Axes Orientation wrt global co-ordinate system:

1, 0, 0
 0, 1, 0
 0, 0, 1

Centroid: 190.6531, -0.794272, 24.5841
 Volume: 104375.4 inch**3
 Mass: 3653.13 MU
 Moment about X axis: 4.32037e+06 MU inch**2
 Moment about Y axis: 3.34173e+07 MU inch**2
 Moment about Z axis: 3.30556e+07 MU inch**2
 Product moment XY: -263037 MU inch**2
 Product moment YZ: -70895.9 MU inch**2
 Product moment ZX: 8.11493e+06 MU inch**2
 Surface area: 15625.2 inch**2

Radius of gyration:
 X axis: 34.3897 inch
 Y axis: 95.643 inch
 Z axis: 95.1248 inch

\$

TURRET MASS PROPERTIES
 COMMANDER CHAIR

\$

SUMMARY OF MASS PROPERTIES

Object number: 8
 Object description: Manipulations
 Mass units - MU; Length units - inch
 Density 8.2
 Axes orientation General
 Reference point L-24.1529, 35.2052, 27.29051
 Axes Orientation wrt global co-ordinate system:
 1, 0, 0
 0, 1, 0
 0, 0, 1

Centroid [-5.8807, 9.94803, 19.82311]
 Volume 818.215 inch**3
 Mass 163.643 MU
 Moment about X axis 152308 MU inch**2
 Moment about Y axis 103966 MU inch**2
 Moment about Z axis 165887 MU inch**2
 Product moment XY -76971.9 MU inch**2
 Product moment YZ 31730.4 MU inch**2
 Product moment ZX -17665.8 MU inch**2
 Surface area 2923.51 inch**2

Radii of gyration:
 X axis 30.5079 inch
 Y axis 25.2055 inch
 Z axis 31.8388 inch

\$

TURRET MASS PROPERTIES
GUNNER CHAIR

SUMMARY OF MASS PROPERTIES

Object number: 0
 Object description: Manipulations
 Mass units - MU; Length units - inch
 Density 0.2
 Axes orientation General
 Reference point [-4.47892, -20.5191, 16.3322]
 Axes Orientation wrt global co-ordinate system:
 1, 0, 0
 0, 1, 0
 0, 0, 1

Centroid [7.59024, 5.28523, -0.212544]
 Volume 926.818 inch**3
 Mass 185.364 MU
 Moment about X axis 183932 MU inch**2
 Moment about Y axis 89485.3 MU inch**2
 Moment about Z axis 157883 MU inch**2
 Product moment XY 58069.7 MU inch**2
 Product moment YZ -79003.9 MU inch**2
 Product moment ZX -33816.2 MU inch**2
 Surface area 2795.72 inch**2

Radii of gyration:
 X axis 31.5004 inch
 Y axis 21.9717 inch
 Z axis 29.1847 inch

\$

TURRET MASS PROPERTIES - GUN (CONCEPT DESIGN)

\$

SUMMARY OF MASS PROPERTIES

Object number: 0
 Object description: Manipulations
 Mass units - MU; Length units - inch
 Density 0.283
 Axes orientation General
 Reference point [0, 0, 0]
 Axes Orientation wrt global co-ordinate system:
 1, 0, 0
 0, 1, 0
 0, 0, 1

Centroid [-67.8411, 0.0559724, 16.97591]
 Volume 24050.4 inch**3
 Mass 6806.27 MU
 Moment about X axis 2.13358e+06 MU inch**2
 Moment about Y axis 6.42524e+07 MU inch**2
 Moment about Z axis 6.22906e+07 MU inch**2
 Product moment XY -60802.8 MU inch**2
 Product moment YZ 6612.63 MU inch**2
 Product moment ZX -7.93157e+06 MU inch**2
 Surface area 12502.6 inch**2

Radii of gyration:
 X axis 17.7051 inch
 Y axis 97.1606 inch
 Z axis 95.6658 inch

\$

TURRET MASS PROPERTIES
 GUN (ENGLISH UNITS)

SUMMARY OF MASS PROPERTIES

Object number: 17
 Object description: Accumulated properties
 Mass units - MU; Length units - inch
 Density 0.283
 Axes orientation Global
 Axes Orientation wrt global co-ordinate system:
 1, 0, 0
 0, 1, 0
 0, 0, 1

Centroid [-90.4116, 0.224029, 46.7896]
 Volume 35601.8 inch**3
 Mass 10075.3 MU
 Moment about X axis 490883 MU inch**2
 Moment about Y axis 5.96868e+07 MU inch**2
 Moment about Z axis 5.96446e+07 MU inch**2
 Product moment XY 141572 MU inch**2
 Product moment YZ 8046.37 MU inch**2
 Product moment ZX -431606 MU inch**2
 Surface area 18343.4 inch**2

Radii of gyration:
 X axis 6.98007 inch
 Y axis 76.968 inch
 Z axis 76.9407 inch

\$

TURRET MASS PROPERTIES
GUN (METRIC UNIT)

Object description: Accumulated properties

Mass units - MU; Length units - mm

Density

1 0, 0, 0 Global

0, 1, 0 Axes Orientation wrt global co-ordinate system:

0, 0, 1

Centroid

Volume

[1016.12, -2.19851, -18.9708]

6.04968e+08 mm**3

Mass

6.04968e+08 MU

mm**2

Kg

4,645

Kg-Cm²

2.00214e+13 MU

Kg-Cm²

2.30152e+15 MU

Kg-Cm²

2.29956e+15 MU

Kg-Cm²

2.23571e+12 MU

Kg-Cm²

1.71923e+11 MU

mm**2

1.94166e+13 MU

mm**2

1.29632e+07 mm**2

mm**2

176,640,000

176,640,000

Radii of gyration:

X axis 181.92 mm

Y axis 1950.48 mm

Z axis 1949.65 mm

HULL MASS PROPERTIES BASIC STRUCTURES

Object description: Accumulated properties
 Mass units - MU; Length units - inch

Density 0.283
 Axes orientation Global
 Axes Orientation wrt global co-ordinate system:
 1, 0, 0
 0, 1, 0
 0, 0, 1

Centroid [-3.10678, 0.856768, -24.2681]
 Volume 84153.9 inch**3
 Mass 23815.6 MU
 Moment about X axis 2.89384e+07 MU inch**2
 Moment about Y axis 1.72286e+08 MU inch**2
 Moment about Z axis 1.919e+08 MU inch**2
 Product moment XY 680560 MU inch**2
 Product moment YZ 25817.9 MU inch**2
 Product moment ZX -960016 MU inch**2
 Surface area 142564 inch**2.

Radii of gyration:
 X axis 34.8583 inch
 Y axis 85.0539 inch
 Z axis 89.7651 inch

HULL MASS PROPERTIES FRONT ARMOR

SUMMARY OF MASS PROPERTIES

Object number: 1
 Object description:
 Mass units - MU; Length units - inch
 Density 0.0936
 Axes orientation Global
 Axes Orientation wrt global co-ordinate system:
 1, 0, 0
 0, 1, 0
 0, 0, 1

Centroid [-116.927, 0.527742, -24.7764]
 Volume 43368.7 inch**3
 Mass 4059.31 MU
 Moment about X axis 2.42776e+06 MU inch**2
 Moment about Y axis 410833 MU inch**2
 Moment about Z axis 2.52974e+06 MU inch**2
 Product moment XY 969.229 MU inch**2
 Product moment YZ -5078.91 MU inch**2
 Product moment ZX -80046.3 MU inch**2
 Surface area 9184.41 inch**2

Radii of gyration:
 X axis 24.4555 inch
 Y axis 10.0602 inch
 Z axis 24.9639 inch

\$

HULL MASS PROPERTIES FUEL TANK

SUMMARY OF MASS PROPERTIES

Object number: 1
 Object description:
 Mass units - MU; Length units - inch
 Density 0.057
 Axes orientation Global
 Axes Orientation wrt global co-ordinate system:
 1, 0, 0
 0, 1, 0
 0, 0, 1
 Centroid [-80.8655, 30.3942, -24.5929]
 Volume 26219.5 inch**3
 Mass 1494.51 MU
 Moment about X axis 172404 MU inch**2
 Moment about Y axis 349730 MU inch**2
 Moment about Z axis 279819 MU inch**2
 Product moment XY 500.249 MU inch**2
 Product moment YZ -558.033 MU inch**2
 Product moment ZX -25162.7 MU inch**2
 Surface area 5622.11 inch**2
 Radii of gyration:
 X axis 10.7405 inch
 Y axis 15.2974 inch
 Z axis 13.6832 inch

\$

HULL MASS PROPERTIES ELECTRICAL CONTROL BOXES

SUMMARY OF MASS PROPERTIES

Object number: 1
 Object description:
 Mass units - MU; Length units - inch
 Density 0.015
 Axes orientation Global
 Axes Orientation wrt global co-ordinate system:
 1, 0, 0
 0, 1, 0
 0, 0, 1

Centroid [-80.8656, -29.9113, -25.2175]
 Volume 26219.5 inch**3
 Mass 393.293 MU
 Moment about X axis 45369.4 MU inch**2
 Moment about Y axis 92034.2 MU inch**2
 Moment about Z axis 73636.6 MU inch**2
 Product moment XY 131.644 MU inch**2
 Product moment YZ -146.851 MU inch**2
 Product moment ZX -6621.76 MU inch**2
 Surface area 5622.11 inch**2

Radii of gyration:
 X axis 10.7485 inch
 Y axis 15.2974 inch
 Z axis 13.6832 inch
 \$

HULL MASS PROPERTIES SKIRTS

Object description: Accumulated properties	
Mass units - MU; Length units - inch	
Density	0.283
Axis orientation	Global
Axis Orientation wrt global co-ordinate system:	
1, 0, 0	
0, 1, 0	
0, 0, 1	
Centroid	[22.6216, 0.122172, -21.9445]
Volume	4656.64 inch**3
Mass	1317.66 MU
Moment about X axis	5.80804e+06 MU inch**2
Moment about Y axis	8.83791e+06 MU inch**2
Moment about Z axis	1.44962e+07 MU inch**2
Product moment XY	9264.63 MU inch**2
Product moment YZ	0.122912 MU inch**2
Product moment ZX	915.063 MU inch**2
Surface area	30465.5 inch**2
Radii of gyration:	
X axis	66.3916 inch
Y axis	81.898 inch
Z axis	104.888 inch

HULL MASS PROPERTIES SPONSONS

Object description: Accumulated properties
 Mass units - MU; Length units - inch
 Density 0.283
 Axes orientation Global
 Axes Orientation wrt global co-ordinate system:
 1, 0, 0
 0, 1, 0
 0, 0, 1

Centroid [55.915, -0.0522779, -6.27638]
 Volume 17383.8 inch**3
 Mass 4919.61 MU
 Moment about X axis 1.43141e+07 MU inch**2
 Moment about Y axis 2.5649e+07 MU inch**2
 Moment about Z axis 3.9792e+07 MU inch**2
 Product moment XY -17198.5 MU inch**2
 Product moment YZ -35324.9 MU inch**2
 Product moment ZX 706158 MU inch**2
 Surface area 55886.8 inch**2

Radii of gyration:
 X axis 53.9408 inch
 Y axis 72.2055 inch
 Z axis 89.9358 inch

HULL MASS PROPERTIES GRILLS

Object description: Accumulated properties
 Mass units - MU; Length units - inch
 Density 0.283
 Axes orientation Global
 Axes Orientation wrt global co-ordinate system:
 1, 0, 0
 0, 1, 0
 0, 0, 1

Centroid [123.309, -0.111899, 0.205881]
 Volume 13824.3 inch**3
 Mass 3912.27 MU
 Moment about X axis 2.26277e+06 MU inch**2
 Moment about Y axis 5.02021e+06 MU inch**2
 Moment about Z axis 7.01383e+06 MU inch**2
 Product moment XY -2970.9 MU inch**2
 Product moment YZ -2612.55 MU inch**2
 Product moment ZX -69749 MU inch**2
 Surface area 23276.5 inch**2

Radii of gyration:
 X axis 24.0495 inch
 Y axis 35.8217 inch
 Z axis 42.3412 inch

HULL MASS PROPERTIES FINAL DRIVE

Object description:
 Mass units - MU; Length units - inch
 Density 0.283
 Axes orientation Global
 Axes Orientation wrt global co-ordinate system:
 1, 0, 0
 0, 1, 0
 0, 0, 1

Centroid [257.38, -8.83868, -8.42325]
 Volume 6284.6 inch**3
 Mass 1778.54 MU
 Moment about X axis 152954 MU inch**2
 Moment about Y axis 74807.9 MU inch**2
 Moment about Z axis 152968 MU inch**2
 Product moment XY 1.73391 MU inch**2
 Product moment YZ 124.324 MU inch**2
 Product moment ZX -9.17407 MU inch**2
 Surface area 3090.02 inch**2

Radii of gyration:
 X axis 9.27359 inch
 Y axis 6.48547 inch
 Z axis 9.27401 inch

HULL MASS PROPERTIES IDLER

Object description:
 Mass units - MU; Length units - inch
 Density 0.283
 Axes orientation Global
 Axes Orientation wrt global co-ordinate system:
 1, 0, 0
 0, 1, 0
 0, 0, 1

Centroid [2.65812, -3.98758, -5.06364]
 Volume 1185.29 inch**3
 Mass 335.437 MU
 Moment about X axis 14571.9 MU inch**2
 Moment about Y axis 14544.8 MU inch**2
 Moment about Z axis 11698.4 MU inch**2
 Product moment XY -1186.38 MU inch**2
 Product moment YZ 2081.32 MU inch**2
 Product moment ZX -1451.86 MU inch**2
 Surface area 2022.07 inch**2

Radii of gyration:
 X axis 6.59102 inch
 Y axis 6.58489 inch
 Z axis 5.90551 inch

HULL MASS PROPERTIES AUTOLOADER

SUMMARY OF MASS PROPERTIES

Object number: 2

Object description:

Mass units - MU; Length units - inch

Density 0.0226

Axes orientation Global

Axes Orientation wrt global co-ordinate system:

1, 0, 0

0, 1, 0

0, 0, 1

Centroid

Volume

Mass

Moment about X axis

Moment about Y axis

Moment about Z axis

Product moment XY

Product moment YZ

Product moment ZX

Surface area

[69.3098, -0.00975291, -26.2518]

159051 inch**3

3594.55 MU

2.32918e+06 MU inch**2

1.28752e+06 MU inch**2

2.83197e+06 MU inch**2

1213.43 MU inch**2

-2786.34 MU inch**2

6408.6 MU inch**2

18568.2 inch**2

Radii of gyration:

X axis 25.4553 inch

Y axis 18.9258 inch

Z axis 28.0687 inch

\$

HULL MASS PROPERTIES POWER PACK

SUMMARY OF MASS PROPERTIES

Object number: 1
 Object description:
 Mass units - MU; Length units - inch
 Density 0.0633
 Axes orientation Global
 Axes Orientation wrt global co-ordinate system:
 1, 0, 0
 0, 1, 0
 0, 0, 1

Centroid [124.609, -0.00134059, -24.9089]
 Volume 166241 inch**3
 Mass 10523.1 MU
 Moment about X axis 6.87798e+06 MU inch**2
 Moment about Y axis 4.09736e+06 MU inch**2
 Moment about Z axis 8.58472e+06 MU inch**2
 Product moment XY 6833.83 MU inch**2
 Product moment YZ -10767.3 MU inch**2
 Product moment ZX 338774 MU inch**2
 Surface area 19500.4 inch**2

Radii of gyration:
 X axis 25.5658 inch
 Y axis 19.7324 inch
 Z axis 28.5622 inch

\$

TURRET SUPPORT REACTION (BEARINGS)

*** Support Reactions *** X

id	LC	x-force LBS	y-force LBS	z-force LBS	x-moment LBS-IN	y-moment LBS-IN	z-moment LBS-IN
36	1	-254.0941	554.1914	57.0693	0.0000	0.0000	0.0000
	2	-.2005E+05	0.4280E+05	-6375.3315	0.0000	0.0000	0.0000
	3	-.2194E+05	0.3015E+05	5857.2934	0.0000	0.0000	0.0000
	4	-79.4353	546.6164	-175.6688	0.0000	0.0000	0.0000
	5	-.2038E+05	0.4390E+05	-6493.9311	0.0000	0.0000	0.0000
	6	-.2227E+05	0.3125E+05	5738.6938	0.0000	0.0000	0.0000
66	1	-280.0328	440.9513	170.1373	0.0000	0.0000	0.0000
	2	1200.9515	0.6856E+05	-.4478E+05	0.0000	0.0000	0.0000
	3	-.2614E+05	0.4464E+05	4724.2275	0.0000	0.0000	0.0000
	4	247.3138	651.3113	-634.0795	0.0000	0.0000	0.0000
	5	1168.2324	0.6965E+05	-.4524E+05	0.0000	0.0000	0.0000
	6	-.2617E+05	0.4573E+05	4260.2851	0.0000	0.0000	0.0000
67	1	-236.5160	559.1224	10.4906	0.0000	0.0000	0.0000
	2	-.3219E+05	0.2164E+05	9379.6767	0.0000	0.0000	0.0000
	3	-.2138E+05	0.1774E+05	7172.0698	0.0000	0.0000	0.0000
	4	-256.8170	414.8857	24.4362	0.0000	0.0000	0.0000
	5	-.3268E+05	0.2261E+05	9414.6035	0.0000	0.0000	0.0000
	6	-.2187E+05	0.1871E+05	7206.9970	0.0000	0.0000	0.0000
89	1	-214.3248	281.4126	202.8566	0.0000	0.0000	0.0000
	2	-3297.1437	0.4329E+05	-.4287E+05	0.0000	0.0000	0.0000
	3	-.4870E+05	0.2470E+05	0.3102E+05	0.0000	0.0000	0.0000
	4	462.5296	440.0636	-877.6386	0.0000	0.0000	0.0000
	5	-3048.9389	0.4401E+05	-.4355E+05	0.0000	0.0000	0.0000
	6	-.4845E+05	0.2543E+05	0.3034E+05	0.0000	0.0000	0.0000
90	1	-299.4963	468.6830	44.0192	0.0000	0.0000	0.0000
	2	-.2966E+05	5727.1875	9866.7822	0.0000	0.0000	0.0000
	3	-.1709E+05	9362.4267	5328.4404	0.0000	0.0000	0.0000
	4	-308.1756	248.1729	78.0799	0.0000	0.0000	0.0000
	5	-.3027E+05	6444.0434	9988.8818	0.0000	0.0000	0.0000
	6	-.1766E+05	0.1008E+05	5450.5395	0.0000	0.0000	0.0000
112	1	18.8011	149.0347	-3.3993	0.0000	0.0000	0.0000
	2	-.5091E+05	-.1158E+05	0.1961E+05	0.0000	0.0000	0.0000
	3	-.3815E+05	-9851.4013	0.2402E+05	0.0000	0.0000	0.0000
	4	-206.0739	30.5238	-27.3365	0.0000	0.0000	0.0000
	5	-.5109E+05	-.1140E+05	0.1958E+05	0.0000	0.0000	0.0000
	6	-.3834E+05	-9671.8427	0.2399E+05	0.0000	0.0000	0.0000
113	1	-518.7282	191.9339	68.6621	0.0000	0.0000	0.0000
	2	-.2115E+05	888.4263	5978.0576	0.0000	0.0000	0.0000
	3	-.1254E+05	5103.6142	2766.0773	0.0000	0.0000	0.0000
	4	-339.8917	112.6519	68.3809	0.0000	0.0000	0.0000

TURRET SUPPORT REACTION (BEARINGS)

ATTU1

MICAS REV 8.8.2
ANALYSIS NO.2

THIN SHELL

DEC 28, 1988 14:18
PAGE 417

*** Support Reactions ***

Node	LC	x-force LBS	y-force LBS	z-force LBS	x-moment LBS-IN	y-moment LBS-IN	z-moment LBS-IN
325	3	-.2026E+05	1515.1131	-2826.5571	0.0000	0.0000	0.0000
	4	-1038.2961	66.3306	-119.3067	0.0000	0.0000	0.0000
	5	-.3251E+05	6872.3442	-.1647E+05	0.0000	0.0000	0.0000
	6	-.2293E+05	1241.3582	-1997.8876	0.0000	0.0000	0.0000
333	1	-266.8231	-368.5695	140.1167	0.0000	0.0000	0.0000
	2	-.2739E+05	-.5784E+05	-.1859E+05	0.0000	0.0000	0.0000
	3	-.4174E+05	-.3962E+05	0.1747E+05	0.0000	0.0000	0.0000
	4	28.6326	-543.7225	-435.9789	0.0000	0.0000	0.0000
	5	-.2763E+05	-.5876E+05	-.1889E+05	0.0000	0.0000	0.0000
	6	-.4198E+05	-.4053E+05	0.1718E+05	0.0000	0.0000	0.0000
380	1	-1501.3331	-519.0402	1511.8194	0.0000	0.0000	0.0000
	2	-.3240E+05	-1698.5906	3652.2590	0.0000	0.0000	0.0000
	3	-.2061E+05	-2711.4775	7667.5439	0.0000	0.0000	0.0000
	4	-1048.2556	-117.4435	364.3771	0.0000	0.0000	0.0000
	5	-.3495E+05	-2335.0747	5528.4555	0.0000	0.0000	0.0000
	6	-.2316E+05	-3347.9614	9543.7402	0.0000	0.0000	0.0000
390	1	-237.5613	-470.9484	47.2341	0.0000	0.0000	0.0000
	2	6068.9604	-.4888E+05	-.3566E+05	0.0000	0.0000	0.0000
	3	-9133.0322	-.3377E+05	-7521.3935	0.0000	0.0000	0.0000
	4	111.8878	-573.5885	-425.9952	0.0000	0.0000	0.0000
	5	5943.2866	-.4992E+05	-.3604E+05	0.0000	0.0000	0.0000
	6	-9258.7060	-.3481E+05	-7900.1547	0.0000	0.0000	0.0000
433	1	-946.0357	-740.7482	1814.6645	0.0000	0.0000	0.0000
	2	-.2928E+05	-8210.4072	0.2038E+05	0.0000	0.0000	0.0000
	3	-.1718E+05	-6110.2543	0.1559E+05	0.0000	0.0000	0.0000
	4	-848.5390	-295.7858	761.6219	0.0000	0.0000	0.0000
	5	-.3108E+05	-9246.9414	0.2296E+05	0.0000	0.0000	0.0000
	6	-.1897E+05	-7146.7885	0.1817E+05	0.0000	0.0000	0.0000
445	1	-188.0081	-484.7857	-7.2419	0.0000	0.0000	0.0000
	2	-9675.6474	-.3137E+05	-6899.0517	0.0000	0.0000	0.0000
	3	-.1027E+05	-.2240E+05	-240.9179	0.0000	0.0000	0.0000
	4	-67.4669	-493.9767	-134.9418	0.0000	0.0000	0.0000
	5	-9931.1220	-.3235E+05	-7041.2358	0.0000	0.0000	0.0000
	6	-.1053E+05	-.2338E+05	-383.1017	0.0000	0.0000	0.0000
494	1	-288.3428	-619.2368	1005.1689	0.0000	0.0000	0.0000
	2	-.2158E+05	-.1170E+05	0.1935E+05	0.0000	0.0000	0.0000
	3	-.1185E+05	-6843.1865	0.1170E+05	0.0000	0.0000	0.0000
	4	-491.2997	-366.3882	608.3247	0.0000	0.0000	0.0000
	5	-.2236E+05	-.1269E+05	0.2096E+05	0.0000	0.0000	0.0000
	6	-.1263E+05	-7828.8115	0.1331E+05	0.0000	0.0000	0.0000

TURRET SUPPORT REACTION (BEARINGS)

ATTD1

MICAS REV 8.8.2

DEC 28, 1988

14:19

ANALYSIS NO.2

THIN SHELL

PAGE 418

*** Support Reactions ***

Node	LC	x-force LBS	y-force LBS	z-force LBS	x-moment LBS-IN	y-moment LBS-IN	z-moment LBS-IN
506	1	-211.1177	-407.6978	25.7549	0.0000	0.0000	0.0000
	2	-.2003E+05	-.1573E+05	6437.8203	0.0000	0.0000	0.0000
	3	-.1229E+05	-.1355E+05	3721.3837	0.0000	0.0000	0.0000
	4	-196.1194	-358.6633	25.7988	0.0000	0.0000	0.0000
	5	-.2043E+05	-.1650E+05	6489.3740	0.0000	0.0000	0.0000
	6	-.1270E+05	-.1432E+05	3772.9375	0.0000	0.0000	0.0000
566	1	-25.6876	-306.2955	326.5323	0.0000	0.0000	0.0000
	2	-.1638E+05	-8090.2065	8767.8593	0.0000	0.0000	0.0000
	3	-9286.8896	-3771.7648	4407.3945	0.0000	0.0000	0.0000
	4	-217.8530	-276.7544	286.8719	0.0000	0.0000	0.0000
	5	-.1662E+05	-8673.2568	9381.2636	0.0000	0.0000	0.0000
	6	-9530.4306	-4354.8149	5020.7988	0.0000	0.0000	0.0000
576	1	-389.2644	-287.1839	58.3607	0.0000	0.0000	0.0000
	2	-.1742E+05	-.1246E+05	5227.1020	0.0000	0.0000	0.0000
	3	-.1035E+05	-.1102E+05	2387.3449	0.0000	0.0000	0.0000
	4	-254.1546	-299.4626	41.8784	0.0000	0.0000	0.0000
	5	-.1806E+05	-.1305E+05	5327.3413	0.0000	0.0000	0.0000
	6	-.1099E+05	-.1161E+05	2487.5842	0.0000	0.0000	0.0000
646	1	51.0307	-246.2756	147.5408	0.0000	0.0000	0.0000
	2	-.1415E+05	-3870.5434	2511.4072	0.0000	0.0000	0.0000
	3	-8690.8574	-1414.3289	971.1271	0.0000	0.0000	0.0000
	4	0.0127	-240.6963	152.4656	0.0000	0.0000	0.0000
	5	-.1410E+05	-4357.5151	2811.4135	0.0000	0.0000	0.0000
	6	-8639.8134	-1901.3009	1271.1336	0.0000	0.0000	0.0000
655	1	-732.0683	-315.0806	-179.6863	0.0000	0.0000	0.0000
	2	-.1371E+05	-.1290E+05	-1932.4252	0.0000	0.0000	0.0000
	3	-9979.2626	-9564.7714	-2102.8730	0.0000	0.0000	0.0000
	4	-377.1217	-286.0310	-77.4530	0.0000	0.0000	0.0000
	5	-.1482E+05	-.1370E+05	-2189.5646	0.0000	0.0000	0.0000
	6	-.1109E+05	-.1037E+05	-2360.0124	0.0000	0.0000	0.0000
721	1	363.3000	-396.4500	155.3629	0.0000	0.0000	0.0000
	2	-.1212E+05	-4214.7304	1134.7403	0.0000	0.0000	0.0000
	3	-7659.7944	-2093.7006	459.3596	0.0000	0.0000	0.0000
	4	281.4858	-377.8491	155.2225	0.0000	0.0000	0.0000
	5	-.1147E+05	-4989.0297	1445.3260	0.0000	0.0000	0.0000
	6	-7015.0087	-2867.9997	769.9451	0.0000	0.0000	0.0000
729	1	-1130.3397	-701.0131	-621.7795	0.0000	0.0000	0.0000
	2	-.1936E+05	-.1456E+05	-.1272E+05	0.0000	0.0000	0.0000
	3	-.1536E+05	-.1018E+05	-8882.5830	0.0000	0.0000	0.0000
	4	-637.6796	-318.2951	-287.4513	0.0000	0.0000	0.0000

TURRET SUPPORT REACTION (BEARINGS)

ATTD1

MICAS REV 8.8.2
ANALYSIS NO.2

THIN SHELL

DEC 28, 1988

14:19
PAGE 419

*** Support Reactions ***

Node	LC	x-force LBS	y-force LBS	z-force LBS	x-moment LBS-IN	y-moment LBS-IN	z-moment LBS-IN
729	5	-.2113E+05	-.1558E+05	-.1363E+05	0.0000	0.0000	0.0000
	6	-.1713E+05	-.1120E+05	-9791.8134	0.0000	0.0000	0.0000
798	1	1036.2781	-867.7082	282.2303	0.0000	0.0000	0.0000
	2	-1246.8627	-7917.7045	-23.5097	0.0000	0.0000	0.0000
	3	-596.8775	-4909.2270	-138.1438	0.0000	0.0000	0.0000
	4	741.9924	-630.1438	231.5961	0.0000	0.0000	0.0000
	5	531.4078	-9415.5566	490.3168	0.0000	0.0000	0.0000
	6	1181.3930	-6407.0795	375.6826	0.0000	0.0000	0.0000
805	1	-1577.3575	-516.0983	-817.8409	0.0000	0.0000	0.0000
	2	-.2115E+05	-.2175E+05	-.3171E+05	0.0000	0.0000	0.0000
	3	-.1831E+05	-.1282E+05	-.1899E+05	0.0000	0.0000	0.0000
	4	-814.3905	-376.2888	-580.8137	0.0000	0.0000	0.0000
	5	-.2354E+05	-.2264E+05	-.3311E+05	0.0000	0.0000	0.0000
	6	-.2070E+05	-.1371E+05	-.2039E+05	0.0000	0.0000	0.0000
862	1	1009.4035	-1460.7938	425.5678	0.0000	0.0000	0.0000
	2	-509.9897	-.1526E+05	-439.5634	0.0000	0.0000	0.0000
	3	-348.6518	-.1065E+05	-320.1556	0.0000	0.0000	0.0000
	4	717.8289	-1013.3742	302.0578	0.0000	0.0000	0.0000
	5	1217.2426	-.1774E+05	288.0621	0.0000	0.0000	0.0000
	6	1378.5805	-.1313E+05	407.4700	0.0000	0.0000	0.0000
878	1	-1823.2998	85.4080	71.4443	0.0000	0.0000	0.0000
	2	-.3453E+05	-.1527E+05	-.3500E+05	0.0000	0.0000	0.0000
	3	-.2607E+05	-7490.0615	-.1754E+05	0.0000	0.0000	0.0000
	4	-1051.7038	-183.6354	-466.9679	0.0000	0.0000	0.0000
	5	-.3740E+05	-.1536E+05	-.3539E+05	0.0000	0.0000	0.0000
	6	-.2895E+05	-7588.2890	-.1794E+05	0.0000	0.0000	0.0000
923	1	1120.3796	-1381.3785	625.6754	0.0000	0.0000	0.0000
	2	2049.4165	-.1462E+05	965.8071	0.0000	0.0000	0.0000
	3	1201.5679	-.1025E+05	515.0379	0.0000	0.0000	0.0000
	4	728.8759	-953.9065	404.8824	0.0000	0.0000	0.0000
	5	3898.6721	-.1696E+05	1996.3649	0.0000	0.0000	0.0000
	6	3050.8237	-.1259E+05	1545.5958	0.0000	0.0000	0.0000
946	1	-1623.9940	413.1006	1016.4624	0.0000	0.0000	0.0000
	2	-.3938E+05	-3680.3847	-.1422E+05	0.0000	0.0000	0.0000
	3	-.2786E+05	-440.7516	-3463.4443	0.0000	0.0000	0.0000
	4	-1056.0656	24.8699	2.5815	0.0000	0.0000	0.0000
	5	-.4206E+05	-3242.4143	-.1320E+05	0.0000	0.0000	0.0000
	6	-.3054E+05	-2.7810	-2444.4003	0.0000	0.0000	0.0000
985	1	1530.8405	-1344.6453	1097.5666	0.0000	0.0000	0.0000
	2	7483.5581	-.1506E+05	5242.4291	0.0000	0.0000	0.0000

TURRET SUPPORT REACTION (BEARINGS)

ATTD1

MICAS REV 6.8.2

DEC 28, 1988

14:19

ANALYSIS NO.2

THIN SHELL

PAGE 420

*** Support Reactions ***

Node	LC	x-force LBS	y-force LBS	z-force LBS	x-moment LBS-IN	y-moment LBS-IN	z-moment LBS-IN
985	3	4686.4194	-1.063E+05	3217.0156	0.0000	0.0000	0.0000
	4	867.2994	-889.5796	623.6818	0.0000	0.0000	0.0000
	5	9881.6982	-1.729E+05	6963.6777	0.0000	0.0000	0.0000
	6	7084.5595	-1.286E+05	4938.2641	0.0000	0.0000	0.0000
1006	1	-1300.7185	763.8793	2145.4096	0.0000	0.0000	0.0000
	2	-3.3856E+05	4776.7978	0.1059E+05	0.0000	0.0000	0.0000
	3	-2.2631E+05	5124.7988	0.1342E+05	0.0000	0.0000	0.0000
	4	-944.8826	227.4895	621.3545	0.0000	0.0000	0.0000
	5	-4.4081E+05	5768.1669	0.1336E+05	0.0000	0.0000	0.0000
	6	-2.2856E+05	6116.1679	0.1618E+05	0.0000	0.0000	0.0000
1041	1	2066.6308	-1.063.4152	1813.5147	0.0000	0.0000	0.0000
	2	0.1418E+05	-1.1302E+05	0.1252E+05	0.0000	0.0000	0.0000
	3	9162.0615	-9380.4179	8019.2353	0.0000	0.0000	0.0000
	4	1072.8503	-679.5886	952.5922	0.0000	0.0000	0.0000
	5	0.1732E+05	-1.1476E+05	0.1529E+05	0.0000	0.0000	0.0000
	6	0.1230E+05	-1.1112E+05	0.1079E+05	0.0000	0.0000	0.0000
1048	1	2402.8081	-527.0577	2340.6958	0.0000	0.0000	0.0000
	2	0.1887E+05	-7756.6206	0.1860E+05	0.0000	0.0000	0.0000
	3	0.1250E+05	-5933.1523	0.1225E+05	0.0000	0.0000	0.0000
	4	1197.5661	-327.8864	1187.4877	0.0000	0.0000	0.0000
	5	0.2247E+05	-8611.5854	0.2213E+05	0.0000	0.0000	0.0000
	6	0.1610E+05	-6788.0966	0.1578E+05	0.0000	0.0000	0.0000
1049	1	2357.2172	92.7177	2297.2834	0.0000	0.0000	0.0000
	2	0.1954E+05	-1064.6671	0.1932E+05	0.0000	0.0000	0.0000
	3	0.1326E+05	-1409.9241	0.1306E+05	0.0000	0.0000	0.0000
	4	1158.1772	63.1795	1151.0111	0.0000	0.0000	0.0000
	5	0.2306E+05	-908.7698	0.2277E+05	0.0000	0.0000	0.0000
	6	0.1678E+05	-1254.0268	0.1651E+05	0.0000	0.0000	0.0000
1059	1	-470.7892	708.1444	2161.1022	0.0000	0.0000	0.0000
	2	-3.3063E+05	0.1256E+05	0.3062E+05	0.0000	0.0000	0.0000
	3	-1.1939E+05	9718.1835	0.2400E+05	0.0000	0.0000	0.0000
	4	-571.6944	388.5559	955.4833	0.0000	0.0000	0.0000
	5	-3.3167E+05	0.1386E+05	0.3374E+05	0.0000	0.0000	0.0000
	6	-2.2043E+05	0.1101E+05	0.2712E+05	0.0000	0.0000	0.0000
1099	1	1960.2038	654.8960	1742.3414	0.0000	0.0000	0.0000
	2	0.1634E+05	5432.7519	0.1480E+05	0.0000	0.0000	0.0000
	3	0.1142E+05	3111.3352	0.1030E+05	0.0000	0.0000	0.0000
	4	976.1085	422.3565	882.2664	0.0000	0.0000	0.0000
	5	0.1927E+05	6510.0043	0.1742E+05	0.0000	0.0000	0.0000
	6	0.1436E+05	4188.5878	0.1293E+05	0.0000	0.0000	0.0000

TURRET SUPPORT REACTION (BEARINGS)

ATTN1

MICAS REV B.B.2

DEC 28, 1968

14:19

ANALYSIS NO.2

THIN SHELL

PAGE 421

*** Support Reactions ***

Node	LC	x-force LBS	y-force LBS	z-force LBS	x-moment LBS-IN	y-moment LBS-IN	z-moment LBS-IN
1115	1	207.0277	755.5904	1082.0546	0.0000	0.0000	0.0000
	2	-.1848E+05	0.1702E+05	0.2631E+05	0.0000	0.0000	0.0000
	3	-.1089E+05	0.1148E+05	0.1777E+05	0.0000	0.0000	0.0000
	4	-125.6902	459.3162	688.7649	0.0000	0.0000	0.0000
	5	-.1840E+05	0.1823E+05	0.2808E+05	0.0000	0.0000	0.0000
	6	-.1081E+05	0.1269E+05	0.1955E+05	0.0000	0.0000	0.0000
1147	1	1343.2218	1030.7711	991.4389	0.0000	0.0000	0.0000
	2	0.1020E+05	0.1004E+05	7704.7197	0.0000	0.0000	0.0000
	3	7516.9448	6462.3671	5646.6157	0.0000	0.0000	0.0000
	4	713.8812	681.8010	531.9371	0.0000	0.0000	0.0000
	5	0.1226E+05	0.1175E+05	9228.0957	0.0000	0.0000	0.0000
	6	9574.0478	8174.9394	7169.9916	0.0000	0.0000	0.0000
1162	1	538.7063	530.9070	456.6375	0.0000	0.0000	0.0000
	2	-.1079E+05	0.1373E+05	0.1245E+05	0.0000	0.0000	0.0000
	3	-6174.7016	8556.0439	7736.9340	0.0000	0.0000	0.0000
	4	216.4391	426.2145	382.1062	0.0000	0.0000	0.0000
	5	-.1004E+05	0.1468E+05	0.1329E+05	0.0000	0.0000	0.0000
	6	-5419.5561	9513.1660	8575.6777	0.0000	0.0000	0.0000
1192	1	803.2297	1136.4099	460.3804	0.0000	0.0000	0.0000
	2	3725.0524	0.1130E+05	2111.9001	0.0000	0.0000	0.0000
	3	3215.4704	7547.8354	1825.0178	0.0000	0.0000	0.0000
	4	507.5852	789.9555	290.9257	0.0000	0.0000	0.0000
	5	5035.8676	0.1322E+05	2863.2065	0.0000	0.0000	0.0000
	6	4526.2856	9474.2001	2576.3242	0.0000	0.0000	0.0000
1194	1	916.3430	659.9765	368.8496	0.0000	0.0000	0.0000
	2	-5524.2480	0.1062E+05	5632.1621	0.0000	0.0000	0.0000
	3	-2773.1635	6662.3232	3463.0075	0.0000	0.0000	0.0000
	4	565.7381	508.1165	297.6970	0.0000	0.0000	0.0000
	5	-4042.1672	0.1179E+05	6298.7089	0.0000	0.0000	0.0000
	6	-1291.0823	7830.4165	4129.5541	0.0000	0.0000	0.0000
1195	1	566.3385	1055.2404	247.8643	0.0000	0.0000	0.0000
	2	-864.5958	0.1006E+05	-524.8756	0.0000	0.0000	0.0000
	3	112.7531	6817.4291	-74.8023	0.0000	0.0000	0.0000
	4	449.8986	787.3642	195.7579	0.0000	0.0000	0.0000
	5	211.6413	0.1191E+05	-81.2532	0.0000	0.0000	0.0000
	6	1128.9903	8660.0341	368.8199	0.0000	0.0000	0.0000
1197	1	1041.8327	935.3052	301.5941	0.0000	0.0000	0.0000
	2	1437.4622	0.1132E+05	2469.9167	0.0000	0.0000	0.0000
	3	2020.4791	7444.3969	1606.9025	0.0000	0.0000	0.0000
	4	736.4599	678.4474	258.5570	0.0000	0.0000	0.0000

*** Support Reactions ***

Node	LC	x-force LBS	y-force LBS	z-force LBS	x-moment LBS-IN	y-moment LBS-IN	z-moment LBS-IN
1	1	-2387.7214	8570.2978	0.1985E+05	0.0000	0.0000	0.0000
2	1	-7237.4443	6297.3242	0.3282E+05	0.0000	0.0000	0.0000
3	1	-1822.6503	1711.5039	0.0000	0.0000	0.0000	0.0000
5	1	-6678.9868	248.4235	0.0000	0.0000	0.0000	0.0000
7	1	-9050.5849	7485.1586	0.2647E+05	0.0000	0.0000	0.0000
8	1	-.1289E+05	-26.9476	0.0000	0.0000	0.0000	0.0000
10	1	-2210.7885	-1047.5627	0.0000	0.0000	0.0000	0.0000
11	1	-7135.8359	-2063.7595	0.0000	0.0000	0.0000	0.0000
14	1	-.1255E+05	-3681.9260	0.0000	0.0000	0.0000	0.0000
16	1	-9039.2841	5159.5502	0.1209E+05	0.0000	0.0000	0.0000
17	1	-.1769E+05	-1060.8132	0.0000	0.0000	0.0000	0.0000
19	1	-.1717E+05	-2869.5354	0.0000	0.0000	0.0000	0.0000
21	1	-3371.9038	146.3775	0.0000	0.0000	0.0000	0.0000
22	1	-9571.8632	-1658.9670	0.0000	0.0000	0.0000	0.0000
23	1	-.1342E+05	-2919.2724	0.0000	0.0000	0.0000	0.0000

Hit <return> to continue (E to escape)

TURRET SUPPORT REACTIONS (TRUNNION)

*** Support Reactions ***

Node	LC	x-force LBS	y-force LBS	z-force LBS	x-moment LBS-IN	y-moment LBS-IN	z-moment LBS-IN
24	1	-.1575E+05	-2374.1516	0.0000	0.0000	0.0000	0.0000
25	1	-4305.5942	3089.6125	-3299.0417	0.0000	0.0000	0.0000
26	1	-.1048E+05	-132.4175	0.0000	0.0000	0.0000	0.0000
28	1	-9699.7441	-1355.4362	0.0000	0.0000	0.0000	0.0000
30	1	-8607.6083	-778.7837	0.0000	0.0000	0.0000	0.0000
31	1	-3902.6889	466.3665	0.0000	0.0000	0.0000	0.0000
32	1	-.1177E+05	-2136.4165	0.0000	0.0000	0.0000	0.0000
33	1	-.1572E+05	-4148.3378	0.0000	0.0000	0.0000	0.0000
34	1	-.1739E+05	-4262.4750	0.0000	0.0000	0.0000	0.0000
35	1	-.1003E+05	-2867.7692	0.0000	0.0000	0.0000	0.0000
1259	1	-.5018E+05	-.1959E+05	4988.2602	0.0000	0.0000	0.0000
1261	1	-.7179E+05	2011.2518	-9458.2578	0.0000	0.0000	0.0000
1263	1	-.4581E+05	5409.1899	-.2665E+05	0.0000	0.0000	0.0000
1268	1	-.1748E+05	6083.9960	-.3486E+05	0.0000	0.0000	0.0000
1279	1	-2079.2988	6298.6386	-.2196E+05	0.0000	0.0000	0.0000

Hit <return> to continue (E to escape)

TABLE 20
TURRET SUPPORT REACTIONS

DISTRIBUTION LIST

	Copies
Commander Defense Technical Information Center Bldg. 5, Cameron Station ATTN: DDAC Alexandria, VA 22304-9990	12
Manager Defense Logistics Studies Information Exchange ATTN: AMXMC-D Fort Lee, VA 23801-6044	2
Commander U.S. Army Tank-Automotive Command ATTN: ASQNC-TAC-DIT (Technical Library) Bldg. 203 Warren, MI 48397-5000	2
Director U.S. Army Materiel Systems Analysis Activity ATTN: AMXSY-MP (Mr. Cohen) Aberdeen Proving Ground, MD 21005-5071	1
Commander U.S. Army Materiel Command ATTN: AMCDRA (Mr. R.O. Black) 5001 Eisenhower Ave Alexandria, VA 22333-0001	1
Commander U.S. Army Armament Research, Development and Engineering Center ATTN: SMCAR-TD Headquarters, Armament Munitions and Chemical Command Picatinny Arsenal, NJ 07806-5000	1
Commander U.S. Army Aviation Systems Command ATTN: AMSAV-GTD (Mr. Charles C. Crawford, Jr.) Federal Center 4300 Goodfellow Blvd. St. Louis, MO 63120-1798	1
Commander U.S. Army Communications-Electronics Command ATTN: AMSEL-ATDD-RT Fort Monmouth, NJ 07703-5001	1

Commander U.S. Army Depot System Command ATTN: Technical Director Chambersburg, PA 17201-4170	1
Commander U.S. Army Laboratory Command ATTN: AMSLC-TD Adelphi, MD 20783-1145	1
Commander U.S. Missile Command ATTN: AMSMI-RD (Technical Director) Redstone Arsenal, AL 35898-5000	1
Commander U.S. Army Tank-Automotive Command ATTN: AMSTA-CF (Dr. K. J. Oscar) Warren, MI 48397-5000	1
Commander U.S. Army Tank-Automotive Command ATTN: AMSTA-TD (Mr. Art Adlam) Warren, MI 48397-5000	20
Commander U.S. Army Test and Evaluation Command ATTN: AMSTE-TD Aberdeen Proving Ground, MD 21005-5055	1
Commander U.S. Army Belvoir Research, Development and Engineering Center ATTN: STRBE-ZT Fort Belvoir, VA 22060-5606	1
Director Ballistic Research Laboratory ATTN: Technical Director Aberdeen Proving Ground, MD 21005-65066	1
Commander and Director Corps of Engineers Waterways Experimental Station ATTN: Technical Director P.O. Box 631 Vicksburg, MS 39181-0631	1

Copies

Program Executive Officer, Combat Support AMCPEO-CS	1
Program Executive Officer, Armored System Modernization AMCPEO-HFM	1
Project Office, Block III AMCPM-Block III	1
Project Manager, Light Armor Vehicle AMCPM-LA	1
Project Manager, Abram Tank System AMCPM,ABMS	1
Project Manager, Bradley Fighting Vehicle System AMCPM,BFVS	1
Project Manager, Advanced Field Artillery System AMCPM-AFAS	1
Project Manager, Future Infantry Fighting Vehicle AMCMP-FIFV	1
Weapon System Management Directorate AMSTA-W	1
Product Management, MGO Family AMCPM-M60	1
Office of Heavy Equipment Transporter SFAE-CS-TVH	1
Deputy Director of R&D Center AMSTA-CV	1
Deputy Director for Engineering and Acq AMSTA-CM	1