

AD-A224 559

REPORT DOCUMENTATION PAGE

Form Approved  
GSA No. 0704-0188

Public Reporting Burden for this collection of information is estimated to average 1 hour per response, including the time for reviewing instructions, searching existing data sources, gathering and maintaining the data needed, reviewing and revising the information, and completing and reviewing the collection of information. Send comments regarding this burden estimate or any aspect of this collection of information, including suggestions for reducing the burden, to Washington Headquarters Service, Directorate for Information Operations and Services, 1215 Jefferson Davis Highway, Suite 1204, Arlington, VA 22202-4302, and to the Office of Management and Budget, Paperwork Reduction Project (0704-0188), Washington, DC 20503.

1. AGENCY USE ONLY (Leave blank) 2. REPORT DATE 3. REPORT TYPE AND DATES COVERED  
Dec 15, 84 - Dec 14, 85

4. TITLE AND SUBTITLE 5. FUNDING NUMBERS  
Specialized Research Equipment. DTIC FILE COPY AFOSR-85 0031 (2)

6. AUTHOR(S)  
John A. Nation

7. PERFORMING ORGANIZATION NAME(S) AND ADDRESS(ES) 8. PERFORMING ORGANIZATION REPORT NUMBER  
Lab of Plasma Studies and School of Electrical Engineering.  
Cornell University  
Ithaca, N.Y. 14853  
AEOSR-TR- 90 0791

9. SPONSORING / MONITORING AGENCY NAME(S) AND ADDRESS(ES) 10. SPONSORING / MONITORING AGENCY REPORT NUMBER

11. SUPPLEMENTARY NOTES

12a. DISTRIBUTION / AVAILABILITY STATEMENT 12b. DISTRIBUTION CODE  
Approved for public release;  
distribution unlimited.

13. ABSTRACT (Maximum 200 words)  
This report details the acquisition, installation and initial operation of equipment purchased under the Specialized Research.  
  
DTIC  
ELECTE  
JUL 26 1990  
S D CS D

14. SUBJECT TERMS 15. NUMBER OF PAGES  
16. PRICE CODE

17. SECURITY CLASSIFICATION OF REPORT 18. SECURITY CLASSIFICATION OF THIS PAGE 19. SECURITY CLASSIFICATION OF ABSTRACT 20. LIMITATION OF ABSTRACT  
Unclassified Unclassified Unclassified Unclassified

**Final Report on**  
**Air Force Office of Scientific Research**  
**Specialized Research Equipment Grant: AFOSR-85-0031**  
**Period Covered: 15-DEC-1984 to 14-DEC-1985**  
**Principal Investigator: John A. Nation**  
**Institution: Lab. of Plasma Studies and**  
**School of Electrical Engineering,**  
**Cornell University,**  
**Ithaca, N.Y. 14853.**

Accession For	
DTIS CRA&I	<input checked="" type="checkbox"/>
DTIC TAB	<input type="checkbox"/>
Unannounced	<input type="checkbox"/>
Justification	
By	
Distribution /	
Availability Codes	
Dist	Avail and/or Special
A-1	

AIR FORCE OFFICE OF SCIENTIFIC RESEARCH  
 SPECIALIZED RESEARCH EQUIPMENT GRANT  
 AFOSR-85-0031  
 PERIOD COVERED: 15-DEC-1984 TO 14-DEC-1985  
 INFORMATION DIVISION



**Approved for public release ;**  
**distribution unlimited.**

## INTRODUCTION

This report details the acquisition, installation and initial operation of equipment purchased under the Specialized Research Equipment Grant AFOSR-85- 0031. A complete list of the equipment is attached.

## System Acquisition.

During 1979 and 1980 we acquired a Tektronix WP2200 Transient Digitizer System with funds from the NSF and DOE. This system has performed satisfactorily and personnel at the lab are familiar with its operation. We have developed extensive software to compliment that provided with the system and to meet our particular needs. The system configuration is shown in figure 1. The change from oscilloscopes to digitizers has greatly improved the analysis and acquisition of data from all experiments in progress at the lab. In view of this it seemed appropriate that any future equipment purchases should be consistent with digital data acquisition and storage.

The original proposal consisted of a Tektronix WP2252 Data Acquisition System, three AD2050 digitizing units and a 7633 storage oscilloscope. Following discussions with the Tektronix Corporation we obtained substantial discounts on several units in the digitizing system. We also obtained a high resolution 4014 display terminal from another department at Cornell and substituted this for the proposed 4012 model. With the necessary modifications carried out by Tektronix this represented an upgrade in display capabilities and a

AIR FORCE OFFICE OF SCIENTIFIC RESEARCH (AFSC)  
NOTICE OF TRANSMITTAL TO DTIC  
This technical report has been reviewed and is  
approved for public release in accordance with AFM 190-12.  
Distribution is unlimited.

MATTHEW J. KERPER  
Chief, Technical Information Division

saving of \$4,700. In addition Tektronix expressed willingness to make a charitable contribution of \$8,000 towards upgrading the proposed system. These considerations provided sufficient funds to substitute an MP2201 Acquisition System for the 7633 oscilloscope.

The MP2201 system consists of a 7612D two channel, 80 MHz waveform digitizer; a 4041, 512k system controller; a 4105 colour display terminal and a 4695 colour graphics copier. The components within this system can function as a stand-alone acquisition unit or be integrated into our main system, based on the 7912AD, 500 MHz digitizers. The colour capabilities of the 4105 and 4695 will be used to enhance the presentation of our experimental results, particularly when overhead projection, or poster display is called for.

#### System Installation

Delivery of the WP2252/AD2050 system components commenced in April 1985 and continued during the summer. The complete system, with the exception of some operation manuals, was installed by June 1985, the configuration is shown in figure 2. The hardware check-out tests showed that one of the 7912AD power supplies was defective. This was replaced by Tektronix under the warranty agreement.

The MP2201 system was delivered in January 1986. Our immediate plans call for the 7612D digitizer to be connected on the GPIB bus, as shown in figure 2. In the future we shall have the flexibility to control the unit independently with the 4041 controller.

### System Operation

The 7912AD acquisition system incorporates some significant advances over our existing units. The use of a GPIB bus to link the components together gives rapid data transfer rates, (up to 250 kbytes/sec i.e. a complete waveform can be transferred in approximately 10 milliseconds), and the ability to connect a wide variety of instruments in the future. The 7912AD accepts programmable plug-ins, allowing settings such as sweep speed and trigger level to be pre-set and written into the operating software, if required. We have chosen to operate with programmable 7B90P time-bases and standard 7A29, high bandwidth amplifiers. At the present time the programmable 7A16P has a 200 MHz bandwidth, which is insufficient for our high frequency microwave experiments.

Following the completed installation in June 1985 software designed to operate the digitizers on a single shot basis was developed. The first operating version was ready for use at the end of July. Since we had written programs for the R7912 system we were familiar with the general requirements of the Tektronix instruments. However the methods for addressing and acquiring data from the digitizers was new, and required extensive new software. The operating software is now capable of setting up a variable number of digitizers depending on the particular experiment in progress.

The program commences with the acquisition of base-line data and any defects that may be present on the diode array, which is the target for the writing electron gun. Following data acquisition the normalized waveforms are displayed on the 4014 terminal. In addition

the waveform data is stored automatically onto disk. The new RK-02 drive allows double density recording, storing up to 512K 8-bit bytes of data per disk. This translates to 194 waveforms, previously we could store a maximum of 96 waveforms per disk.

A number of routines have been written to enable rapid analysis of the acquired data. These include risetime determination, pulsewidth measurement, integration and differentiation of waveforms, time correlation and Fast Fourier transformations. An example of a Fourier transform is shown in figure 3. Also shown is the bandwidth capabilities of the 7A29 amplifier which is rated at 500 MHz when in the 7912AD. The nominal 1.6 GHz signal can be displayed adequately, although the 13 dB attenuation at these frequencies renders amplitude determination unreliable.

Examples of data acquired with the new system are shown in figures 4 and 5. Figure 4 shows the signals from a Faraday cup array used to measure proton current in the Linear Induction Proton Accelerator experiment in progress at the Lab. The waveforms displayed give the current as a function of time for different radial positions. A total of seven signals are routinely monitored and the axial position of the array is varied from shot to shot. Software has been developed to convert this data into radial profiles of the proton current density as a function of axial distance from the diode. This data, for various times after the start of the voltage pulse, is shown in figure 5. The data reduction process involved in this experiment would be extremely time consuming without the new digitizer system.

## Future Plans

### System Configuration

At the present time we are able to operate our three digitizing systems independently. Our first objective is to develop software to link the 7612D unit into the 7912AD system, giving a six channel digitizing capability. Following this we aim to link the R7912 system, through the 4041 controller, to the GPIB bus and be able to set up and control a total of nine channels from the 4014 terminal. This will allow us to obtain comprehensive data on a single shot basis, rather than having to select, as we do at present, which diagnostics to monitor during an experimental run.

In the near future we are hoping to establish a long range microwave link from the High Voltage Lab to the Electrical Engineering Department. This will allow us access to the VAX 11/780 computer, which will enhance our data analysis and waveform processing capabilities.

### Software Development

The software that runs the 7912AD system at present is based on manual set-up of the digitizers. Future development will allow time-base settings, writing beam intensities and 7A16P amplifier settings to be programmed for particular experimental requirements. This will ensure that the instrument settings are identical on a day-to-day basis, and thus improve the consistency of our data acquisition.

**Conclusions**

The equipment purchased under grant AFOSR-85-0031 has been installed, and is performing data acquisition on a daily basis. Additional costs of \$4,672, incurred as a result of upgrading the system, have been fully met from Cornell funds. Future software development, to be carried out at the High Voltage Lab, will improve performance by allowing integration of the components into one operating system.



Figure 1  
The WP2200 System

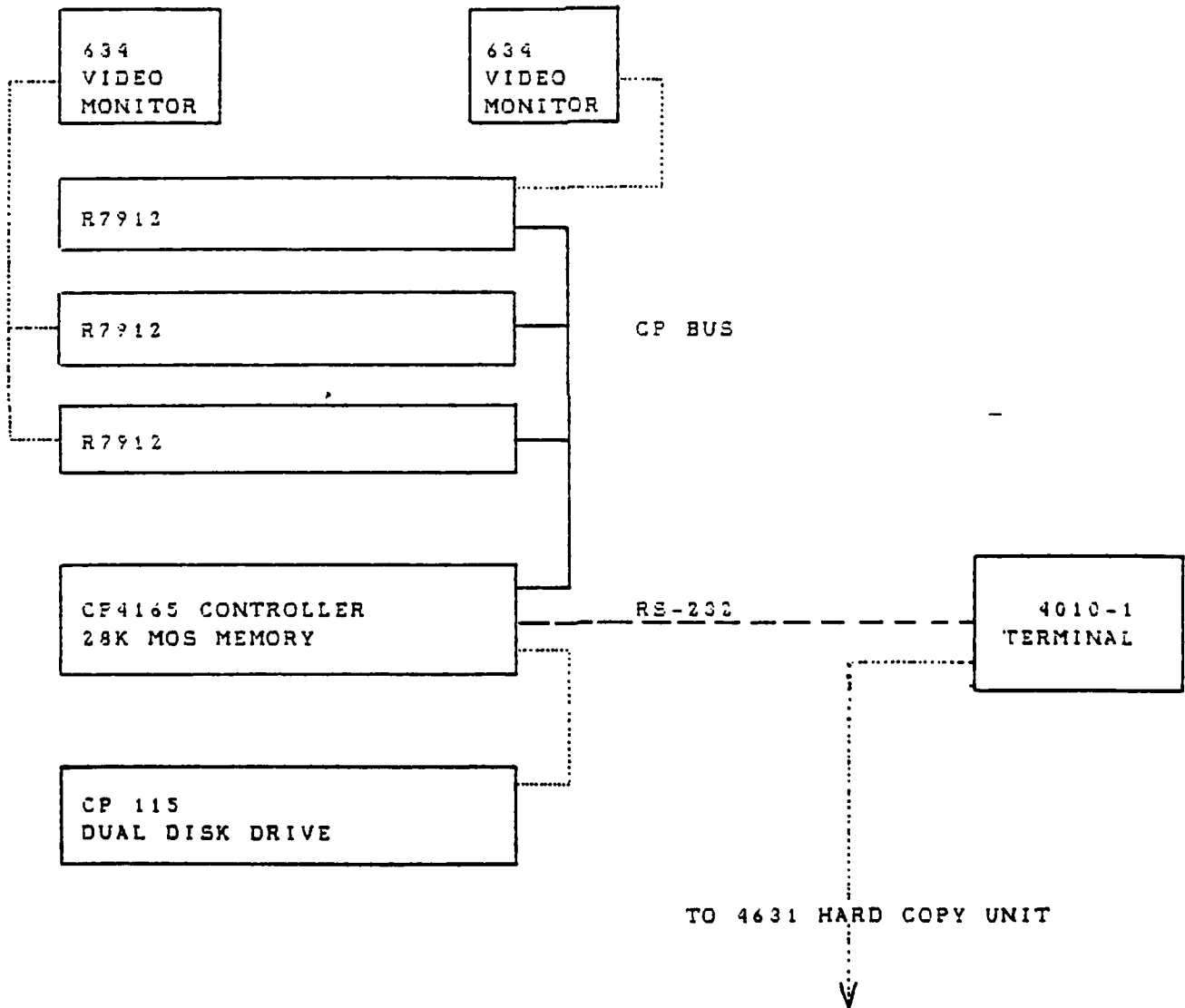
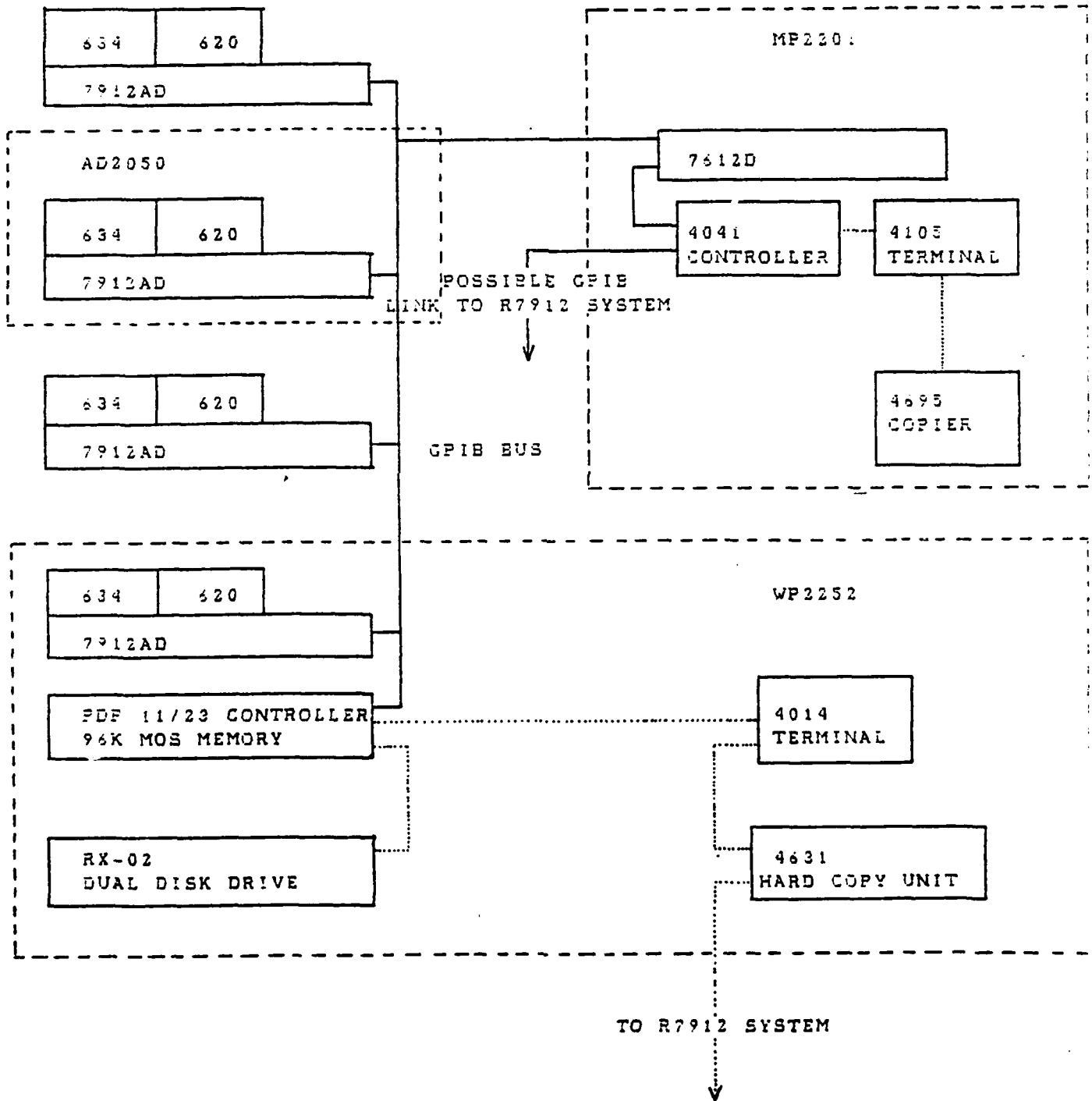
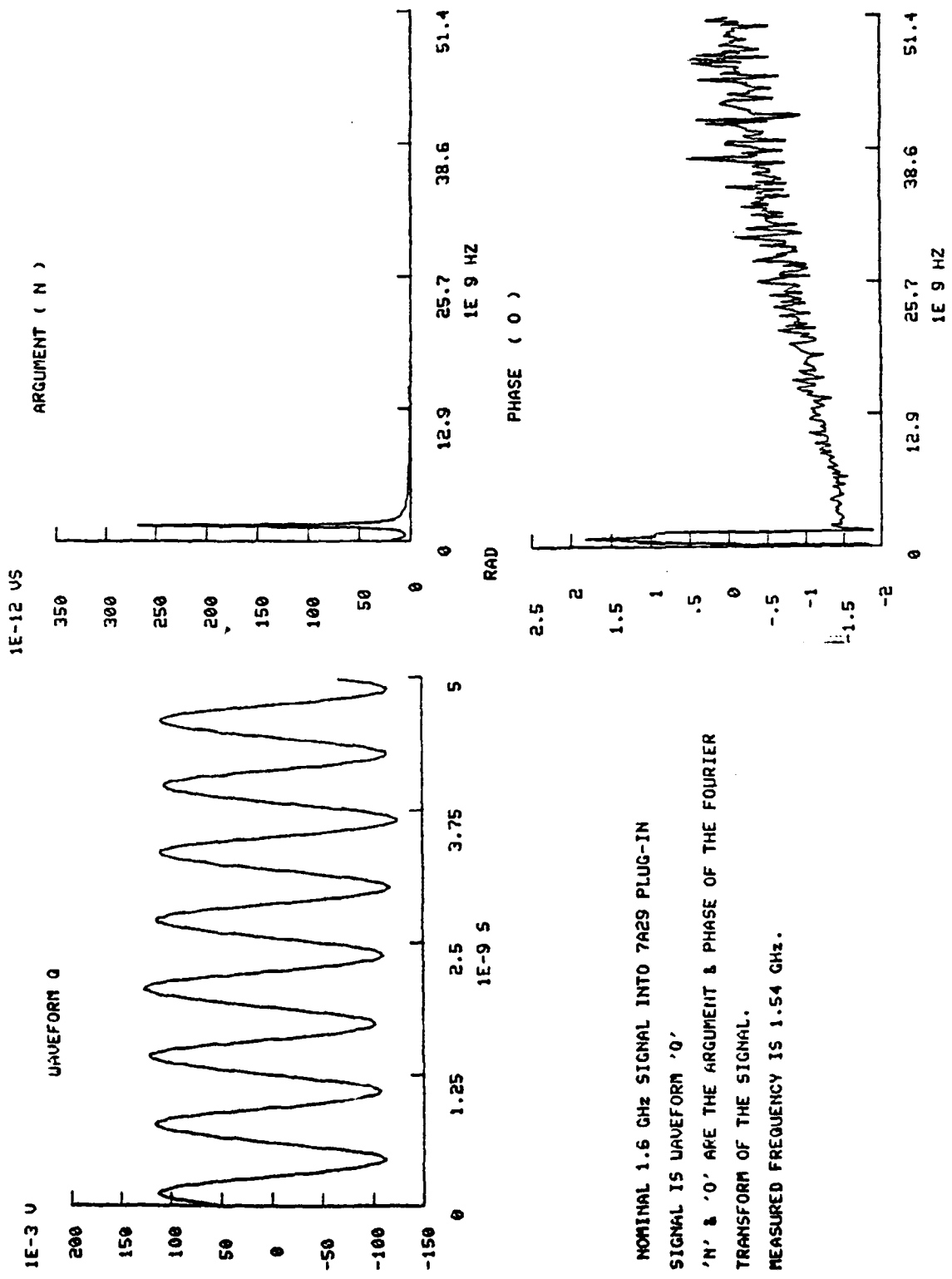

Figure 2  
The WP2252 and MP2201 Systems





NOMINAL 1.6 GHz SIGNAL INTO 7A29 PLUG-IN  
 SIGNAL IS WAVEFORM 'O'  
 'N' & 'O' ARE THE ARGUMENT & PHASE OF THE FOURIER  
 TRANSFORM OF THE SIGNAL.  
 MEASURED FREQUENCY IS 1.54 GHz.

Figure 3.

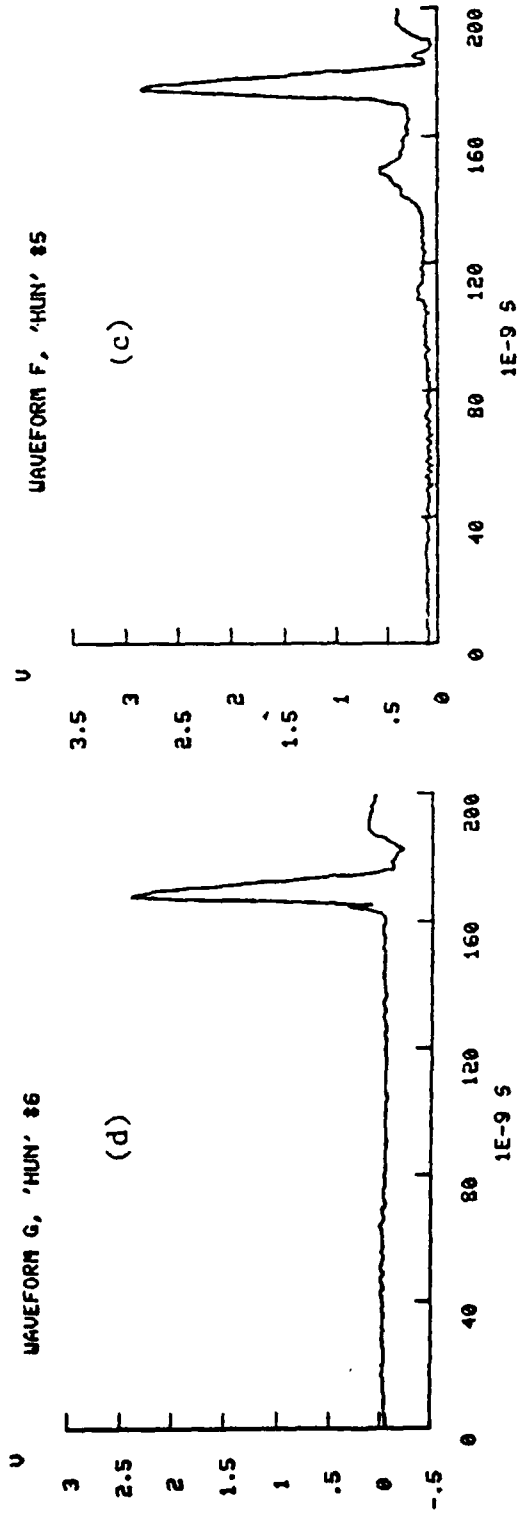
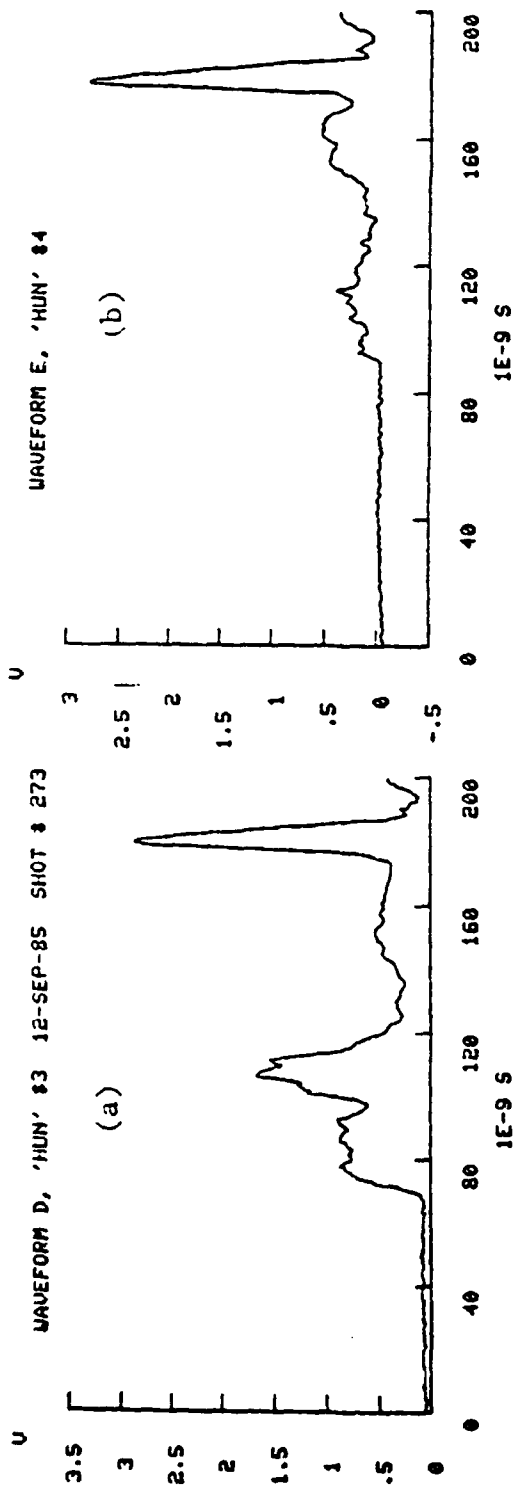

Figure 4. Faraday cup signals from cups at various radii. (a) 4.4 cm (b) 5.1 cm (c) 5.9 cm (d) 6.6 cm. Drift tube radius is 7.5 cm. Axial position is 28 cm from diode.

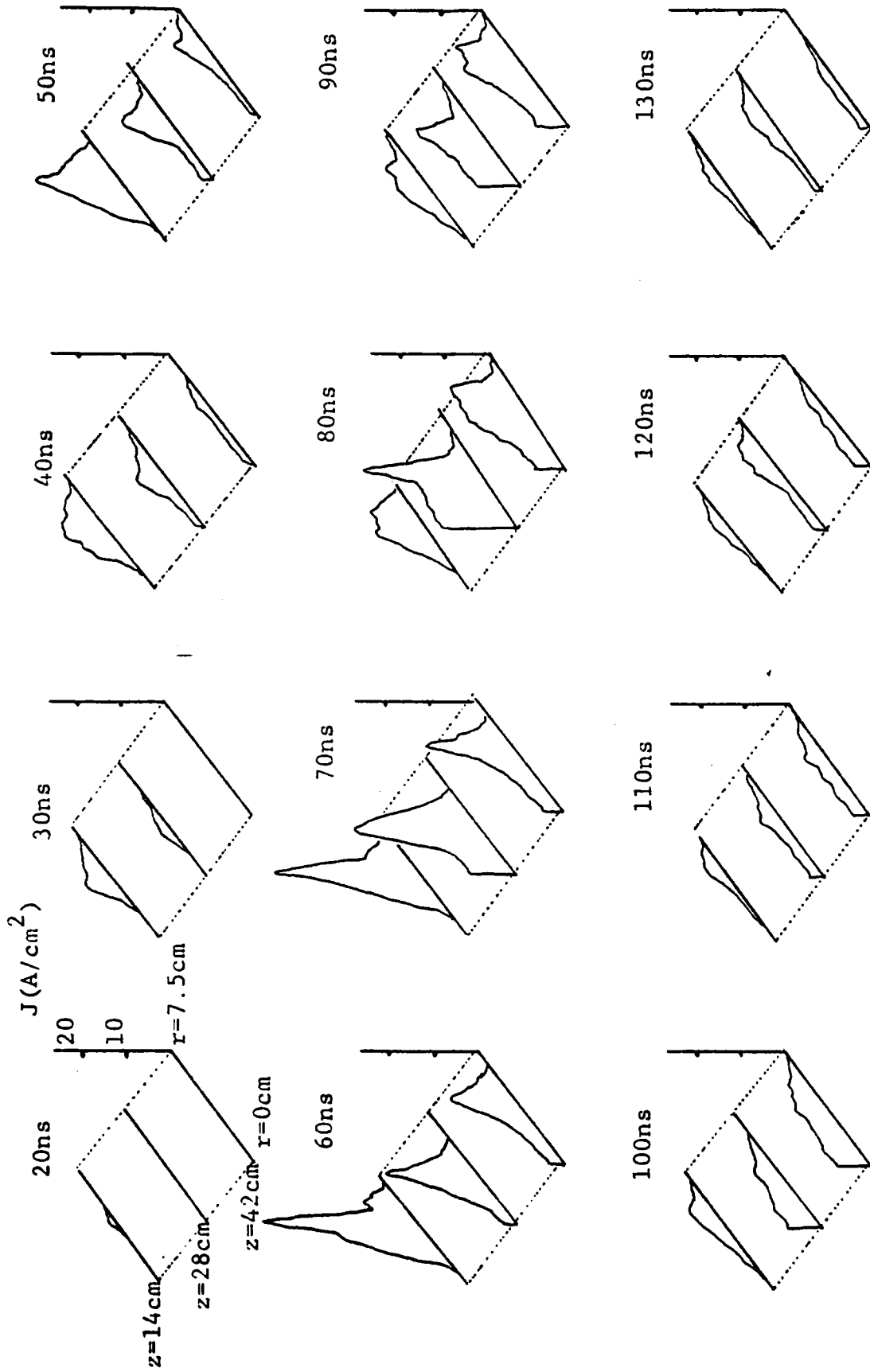

Figure 5. Radial profiles of the proton current density at three axial positions from the diode. Times are after the start of the voltage pulse.

EQUIPMENT LIST

WP2252 DATA ACQUISITION SYSTEM:

1	7912AD digitizer with plug-ins. (7A29, 7B90P).	
1	PDP 11/23 controller	
1	620 x-y display monitor	
1	634 raster scan monitor	
1	RK02 dual disk drive	
1	4631 hard copy unit	
	TOTAL COST:	\$76,889
1	4014 terminal	\$1,500

AD2050 DIGITIZER UNIT.

1	7912AD digitizer with plug-ins. (7A29, 7B90P).	
1	620 x-y display monitor	
1	634 raster scan monitor	
	UNIT COST	\$36,849
	TOTAL COST:	\$110,547

MP2301 DATA ACQUISITION SYSTEM:

1	7612D digitizer with plug-ins. (2-7A16P).	
1	4041 system controller	
1	4105 colour display terminal	
1	4695 colour graphics copier	
	TOTAL COST:	\$39,736
	Less Tektronix charitable contribution	( 8,000)
	TOTAL COST:	\$220,672
	Less Cornell funds	(4,672)
	NET COST:	\$216,000