

2

AIR FORCE



AD-A222 407

HUMAN RESOURCES

**ADVANCED ON-THE-JOB TRAINING SYSTEM:
OPERATIONAL GUIDE**

Douglas Aircraft Company
A Division of McDonnell Douglas Corporation
2450 South Peoria
Aurora, Colorado 80014

TRAINING SYSTEMS DIVISION
Brooks Air Force Base, Texas 78235-5601

April 1990
Interim Technical Paper for Period August 1985 - December 1989

Approved for public release; distribution is unlimited.

LABORATORY

**AIR FORCE SYSTEMS COMMAND
BROOKS AIR FORCE BASE, TEXAS 78235-5601**

90 05 24 105

NOTICE

When Government drawings, specifications, or other data are used for any purpose other than in connection with a definitely Government-related procurement, the United States Government incurs no responsibility or any obligation whatsoever. The fact that the Government may have formulated or in any way supplied the said drawings, specifications, or other data, is not to be regarded by implication, or otherwise in any manner construed, as licensing the holder, or any other person or corporation; or as conveying any rights or permission to manufacture, use, or sell any patented invention that may in any way be related thereto.

The Public Affairs Office has reviewed this paper, and it is releasable to the National Technical Information Service, where it will be available to the general public, including foreign nationals.

This paper has been reviewed and is approved for publication.

HENDRICK W. RUCK, Technical Advisor
Training Systems Division

RODGER D. BALLENTINE, Colonel, USAF
Chief, Training Systems Division

This technical paper is printed as received and has not been edited by the AFHRL Technical Editing staff. The opinions expressed herein represent those of the author and not necessarily those of the United States Air Force.

REPORT DOCUMENTATION PAGE

Form Approved
OMB No. 0704-0188

Public reporting burden for this collection of information is estimated to average 1 hour per response, including the time for reviewing instructions, searching existing data sources, gathering and maintaining the data needed, and completing and reviewing the collection of information. Send comments regarding this burden estimate or any other aspect of this collection of information, including suggestions for reducing this burden, to Washington Headquarters Services, Directorate for Information Operations and Reports, 1215 Jefferson Davis Highway, Suite 1204, Arlington, VA 22202-4302, and to the Office of Management and Budget, Paperwork Reduction Project (0704-0188), Washington, DC 20503.

1. AGENCY USE ONLY (Leave blank)		2. REPORT DATE April 1990	3. REPORT TYPE AND DATES COVERED Interim - August 1985 to December 1989	
4. TITLE AND SUBTITLE Advanced On-the-job Training System: Operational Guide			5. FUNDING NUMBERS C - F33615-84-C-0059 PE - 63227F PR - 2557 TA - 00 WU - 02	
6. AUTHOR(S)				
7. PERFORMING ORGANIZATION NAME(S) AND ADDRESS(ES) Douglas Aircraft Company A Division of McDonnell Douglas Corporation 2450 South Peoria Aurora, Colorado 80014			8. PERFORMING ORGANIZATION REPORT NUMBER	
9. SPONSORING / MONITORING AGENCY NAME(S) AND ADDRESS(ES) Training Systems Division Air Force Human Resources Laboratory Brooks Air Force Base, Texas 78235-5601			10. SPONSORING / MONITORING AGENCY REPORT NUMBER AFHRL-TP-89-86	
11. SUPPLEMENTARY NOTES				
12a. DISTRIBUTION / AVAILABILITY STATEMENT Approved for public release; distribution is unlimited.			12b. DISTRIBUTION CODE	
13. ABSTRACT (Maximum 200 words) <p>The Advanced On-the-job Training System (AOTS) Operational Guide contains a description of the prototype AOTS. It identifies the users of the AOTS prototype, the functions they will perform, and how the prototype provides automated support for the performance of those functions. The document was developed for use primarily by personnel within the operational work centers chosen to participate in the AOTS System Level Testing and Evaluation which began 1 August 1988 and concluded 31 July 1989. The purpose of the document is to provide the information needed to allow the new AOTS users to transition from the conventional on-the-job training system to the prototype AOTS.</p>				
14. SUBJECT TERMS advanced on-the-job training system operational guide			15. NUMBER OF PAGES 74	
			16. PRICE CODE	
17. SECURITY CLASSIFICATION OF REPORT Unclassified	18. SECURITY CLASSIFICATION OF THIS PAGE Unclassified	19. SECURITY CLASSIFICATION OF ABSTRACT Unclassified	20. LIMITATION OF ABSTRACT UL	

SUMMARY

The Advanced On-the-job Training System (AOTS) was an Air Staff directed, AFHRL developed, prototype system which designed, developed, and tested a proof-of-concept prototype AOTS within the operational environment of selected work centers at Bergstrom AFB, Texas, and Ellington ANGB, Texas, from August 1985 through 31 July 1989. The AOTS Operational Guide contains a description of the prototype AOTS. It identifies the users of the AOTS prototype, the functions they will perform, and how the prototype AOTS document was developed for use primarily by personnel within the AOTS operational work centers chosen to participate in the AOTS System Level Test and Evaluation which began 1 August 1988 and concluded 31 July 1989. The purpose of the document is to provide the information needed to allow the new AOTS users to transition from the conventional on-the-job training system to the prototype AOTS.

Accession For	
NTIS CRA&I	<input checked="" type="checkbox"/>
DTIC TAB	<input checked="" type="checkbox"/>
Unannounced	<input type="checkbox"/>
Justification	
A-1	

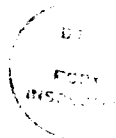

PREFACE

This paper was prepared by Douglas Aircraft Company, the AOTS development contractor, under Government Contract Number F33615-84-C-0059. The AFHRL Work Unit number for the project is 2557-00-02. The primary office of responsibility for management of the work unit is the Air Force Human Resources Laboratory, Training Systems Division, and the Air Force AOTS manager is Major Jack Blackhurst.

Table of Contents

1	EXECUTIVE SUMMARY	1
2	INTRODUCTION	4
2.1	Purpose	4
2.2	System Level Test and Evaluation (SLT&E) Period	4
2.3	AOTS Description	4
2.4	AOTS External Interfaces	5
2.5	AOTS Requirements/Functions and the Subsystems Matrix	6
3	SCOPE	7
3.1	Scope of the Operational Guide	7
3.2	Participating Organizations and Air Force Specialties (AFSs)	7
3.3	Background	8
3.3.1	System Definition Study	9
3.3.2	Design and Development of the Prototype AOTS	10
4	THE OPERATIONAL ENVIRONMENT AND USERS OF THE PROTO- TYPE AOTS	11
4.1	The Operational Environment	11
4.2	Users of the Prototype AOTS	11
4.2.1	Trainee	12
4.2.2	Trainer	12
4.2.3	Evaluator	12
4.2.4	Supervisor	12
4.2.5	Training Manager	13
4.2.6	Quality Control Administrator	13
4.2.7	Commander	14
4.2.8	AOTS Support Personnel	14
4.2.8.1	System Administrator	14
4.2.8.2	Developer	14
4.2.8.3	System Programmer	14
5	DEVELOPMENT OF TRAINING MATERIALS FOR THE PROTOTYPE AOTS	15
5.1	Analysis of Performance Requirements	15
5.2	Developing Behavioral Objectives	17
5.3	Developing Evaluation Materials	17
5.4	Developing Tests	18
5.5	Developing Instruction	18
5.6	Developing Generic Position Task Requirments (GPTR) Lists	19
6	USING THE PROTOTYPE AOTS IN THE OPERATIONAL ENVIRONMENT	20
6.1	Assignment of a Trainee to a Workcenter	20
6.2	Planning Training	23
6.3	Scheduling Training Events	23
6.4	Conducting Training	24
6.5	Evaluating Training	26
6.6	Recording Trainee Progress	27
6.7	Performing Quality Control Evaluations	27
6.8	Generating Training Reports and Notices	28
7	OPERATIONAL SUPPORT	30
7.1	Problem Reporting	30
7.2	Hot Line Support	30
7.3	AFHRL/IDD/OL-AK AOTS Program Organization	30
8	GLOSSARY OF TERMS	32
9	APPLICABLE DOCUMENTS	34

10	APPENDIX A -- ATR Screen Displays	37
11	APPENDIX B -- The Prototype AOTS Configuration	42
11.1	System Architecture	42
11.2	Communications	44
11.3	Bergstrom AFB Installation	45
11.4	Ellington ANGB Installation	47
11.5	Hardware Selection Process	49
11.5.1	Trade Studies	49
11.5.2	Selection Process	53
11.5.3	Phased Procurements	53
11.5.4	Reliability, Availability, and Maintainability	53
11.5.4.1	Reliability Data	54
11.5.4.2	Maintainability Data	54
11.5.4.3	Availability Data	56
11.5.4.4	Software Maintainability	56
11.5.4.5	Performance Goals	56
11.6	Software Architecture	57
11.6.1	Software Development	57
11.6.2	Software Architecture	57
11.6.3	Standards Used	59
11.6.4	Computer Program Structure	59
11.6.5	Top Down Design (TDD)	59
11.6.6	Top Down Implementation (TDI)	59
11.6.7	Structured Coding and Operating System Requirements	60
11.6.8	Unit Development Folders	60
11.6.9	Utility Software Services	60
11.6.10	Usage of ISS	61
11.7	Glossary Of Terms And Acronyms - APPENDIX B	62

Table of Figures

1-1	The AOTS Master Schedule	1
1-2	The Advanced On-the-job Training System - AOTS	2
1-3	The Prototype AOTS Hardware Configuration	3
2-1	The AOTS Components	5
2-2	AOTS External Interfaces	5
3-1	The AOTS Air Force Major Participants and Commands	7
3-2	The AOTS Participants	8
3-3	Inspector General's Findings/Recommendations and Subsequent Actions	9
4-1	The Operational Users	11
5-1	Development Functional Sequence	15
5-2	Analysis of Performance Requirements	16
5-3	Development of Behavioral Objectives and Evaluation Materials	17
5-4	Computer Assisted Training Development Sequence	19
5-5	GPTR Development	19
6-1	The Airman Training Record Categories	20
6-2	Training Process	21
6-3	Standardized Training Reports	28
6-4	Personnel Change Notices	29
7-1	The AOTS Program Organization with AFHRL	31
11-1	The Prototype AOTS Hardware Configuration	43
11-2	The Bergstrom/Brooks AFB Communication System	45
11-3	Bergstrom Communication Layout	46
11-4	Ellington ANGB Equipment and Communication Layout	47
11-5	The AOTS Software Architecture	58
11-6	A Sample Vertical Interface Diagram	58

Table of Tables

2-1	Requirements/Functions Cross Reference Matrix	6
4-1	Performance Hierarchies	16
11-1	AOTS Prototype Equipment Types and Quantities	44
11-2	The Bergstrom Equipment List by Organization and Building	46
11-3	The Ellington ANGB Equipment Distribution by Building	48
11-4	- Air National Guard Equipment List for SLT&E	48
11-5	AOTS Central Computer System Requirements	49
11-6	The AOTS Terminal Specifications	51
11-7	AOTS Peripheral Specifications	52
11-8	Reliability Goals for the Prototype AOTS	54
11-9	Maintainability Data on the Prototype AOTS	55
11-10	The Prototype AOTS Availability Goals	56

1 EXECUTIVE SUMMARY

This document contains a description of a prototype Advanced On-the-job Training System (AOTS) that was designed and developed by the Air Force Human Resources Laboratory (AFHRL). Further, it identifies the users of the prototype AOTS, the functions they will perform, and how the prototype AOTS provides automated support for the performance of those functions. This document was developed for use primarily by personnel within those operational workcenters that have been chosen to participate in a System Level Test and Evaluation (SLT&E) of the prototype AOTS. The purpose of this document is to provide the information needed to transition from the conventional On-the-Job Training (OJT) system to the prototype AOTS.

AFHRL was tasked by the Air Staff to design, develop, and test the prototype AOTS within an operational setting. This initiative was established as a result of findings during studies of on-the-job training programs within operational units. Reports of these studies identified several deficient areas within the on-the-job training system. The timeline for the design, development, and test of the prototype AOTS is presented in Figure 1-1.

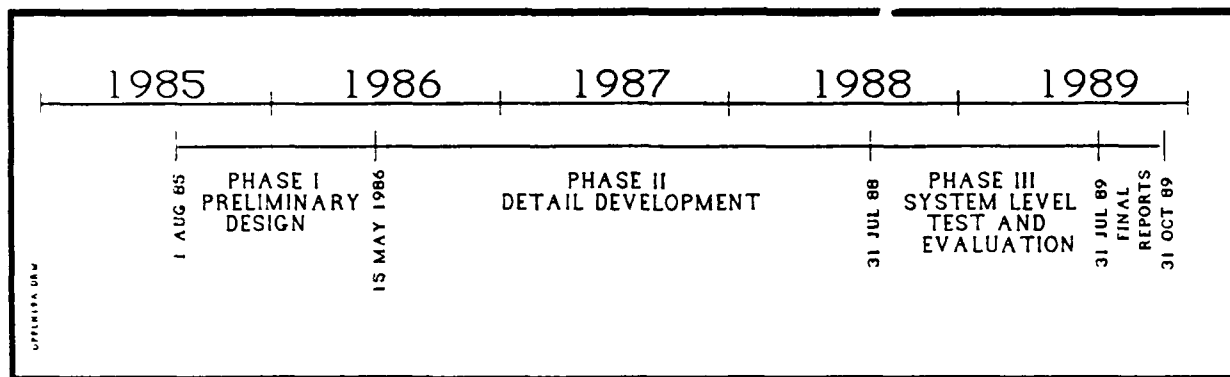

Figure 1-1 The AOTS Master Schedule

The prototype AOTS is a computer-based training system that employs modern computer technology to develop and deliver instructional and test materials, manage trainee progress through full duty position qualification, and evaluate the effectiveness and efficiency of the training system. The data base for this system consists of the following data:

- a) Automated Airman Training Records - personnel data, the status of ongoing training and the history of completed training;
- b) Master Task Lists - the tasks assigned to each Air Force Specialty, to include the task elements;
- c) Behavioral Objectives - terminal and supporting behavioral objectives to support training and evaluation of tasks and subtasks;
- d) Evaluation Materials - knowledge and performance tests for use in determining attainment of behavioral objectives;

- e) Other Training Requirements - ancillary training, additional duty training, contingency tasks, and career development courses;
- f) Event Schedules - training and evaluation event schedules, and lists of resources required for each; and
- g) System Evaluation Data - test results, training times, airmen qualifications, and other data used to indicate training efficiency and effectiveness.

Bergstrom AFB, TX was chosen as the development site for the prototype AOTS. Bergstrom and Ellington ANGB, TX have been selected as the sites at which the SLT&E will occur. All Air Force components; active, reserve, and guard, will participate in the SLT&E. The following five AFSSs will be included in the test.

- a) Jet Engine Maintenance, Air Force Specialty Code (AFSC) 426X2;
- b) Aircraft Maintenance, AFSC 431X1;
- c) Personnel, AFSC 732X0;
- d) Security Police - Security, AFSC 811X0; and
- e) Security Police - Law Enforcement, AFSC 811X2.

Workcenters within the 67th Tactical Reconnaissance Wing (active) and the 924th Tactical Fighter Group (reserve) at Bergstrom, and the 147th Fighter Interceptor Group (Guard) at Ellington, will participate in the SLT&E. All participants will help determine if the prototype AOTS meets established goals, and whether Air Force-wide implementation should be considered.

Figure 1-2 shows the five major subsystems that constitute the prototype AOTS. The core of AOTS is the data base itself. It is within the data base that information is stored, retrieved, user interacts with, and reported upon.

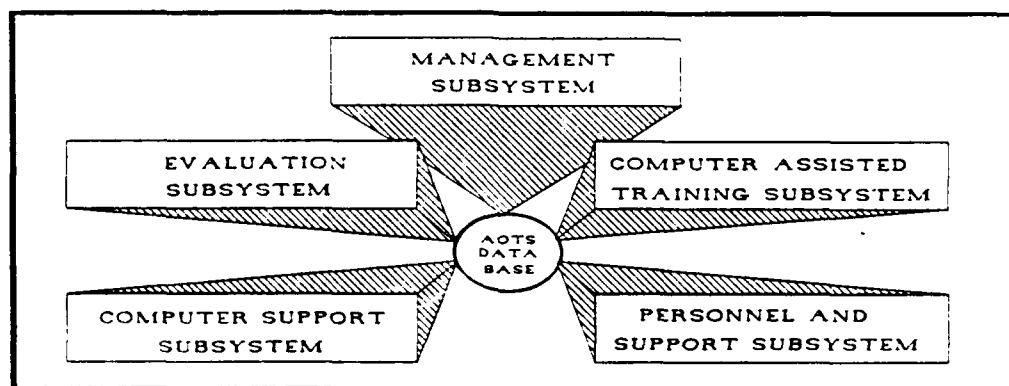

Figure 1-2 The Advanced On-the-job Training System - AOTS

The prototype AOTS is using a central computer system with Z-248 Personal Computers (PCs) as local AOTS terminals. Figure 1-3 provides a diagram of the system configuration. High speed digital communication lines between the central computer and the Z-248s are provided. More than 85 PCs are used throughout the AOTS. The central computer is capable of handling more than 10 million operations per second, and storing more than 1300 million characters of data. The workcenter users are provided printing capabilities, and optical mark readers for scoring tests that are administered off-line. Appendix B provides details on the implementation and installation of the prototype AOTS.

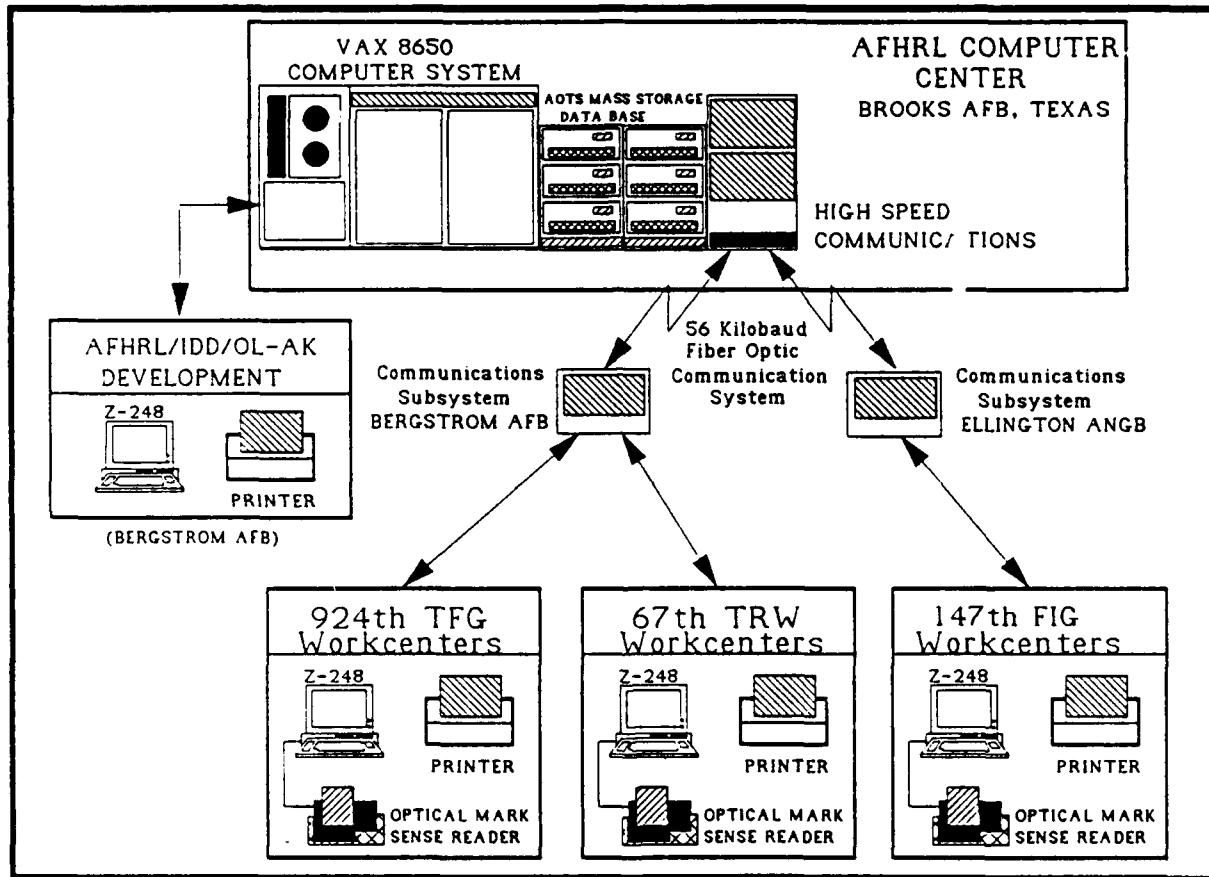

Figure 1-3 The Prototype AOTS Hardware Configuration

2 INTRODUCTION

2.1 Purpose

The purpose of this Operational Guide is to provide the information needed during the System Level Test and Evaluation (SLT&E) of the prototype Advanced On-the-job Training System (AOTS) to transition from the conventional Air Force on-the-job training system to the prototype AOTS. This description has been developed primarily for use by those personnel assigned to the operational workcenters that have been chosen to participate in the SLT&E of the prototype AOTS.

2.2 System Level Test and Evaluation (SLT&E) Period

The prototype AOTS will undergo SLT&E during the period 1 August 1988 through 31 July 1989. The SLT&E is intended to demonstrate a proof-of-concept (i.e. to attempt to prove that the prototype AOTS provides the functionality necessary to meet the requirements of the Air Force on-the-job training system, and that the prototype AOTS is more effective and efficient than the conventional on-the-job training system). Data required to substantiate that the concept works will be collected during the SLT&E period and analyzed and reported at the end of the period. All computer hardware and software necessary to support the prototype AOTS will be made available to the participating organizations prior to the start of SLT&E. Also prior to the start of the SLT&E personnel participating will receive training on how to operate the system and on the use of system generated products.

2.3 AOTS Description

The prototype AOTS is a computer-based training system designed to provide automated support for the functional requirements of the Air Force on-the-job training system. The AOTS is comprised of five subsystems. Each subsystem is made up of components that perform specific functions. Figure 2-1 illustrates the functional hierarchy of the prototype AOTS including the five subsystems and the components of each subsystem. The functions and how they are applied are described within subsequent sections of this plan.

The Management, Evaluation, and Computer Assisted Training subsystems are the principal subsystems within the prototype AOTS that provide training support functions. The Computer Support Subsystem supports AOTS users by providing the necessary hardware and software to interact with the AOTS data base. The Personnel and Support subsystem defines the personnel requirements for AOTS, specifically, the maintenance and logistics requirements, and the human factors (or man/machine interface) requirements. All internal interfaces between subsystems are fully integrated together.

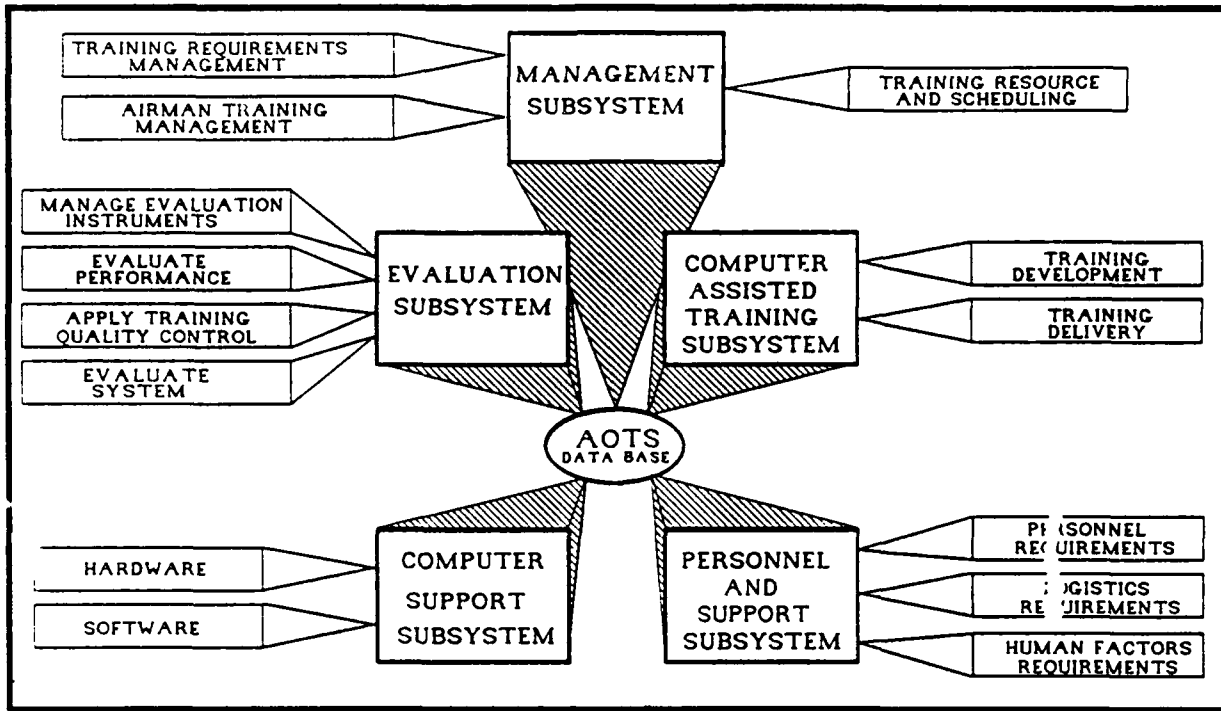

09PLA47.DRW

Figure 2-1 The AOTS Components

2.4 AOTS External Interfaces

For an AOTS to function effectively, it must exchange data with other Air Force systems. These external interfaces have been established for the prototype AOTS and are illustrated in Figure 2-2. A fully operational AOTS (one that has been approved for Air Force-wide use) would interface electronically with external Air Force systems. However, the interfaces between the prototype AOTS and these external systems will be accomplished manually.

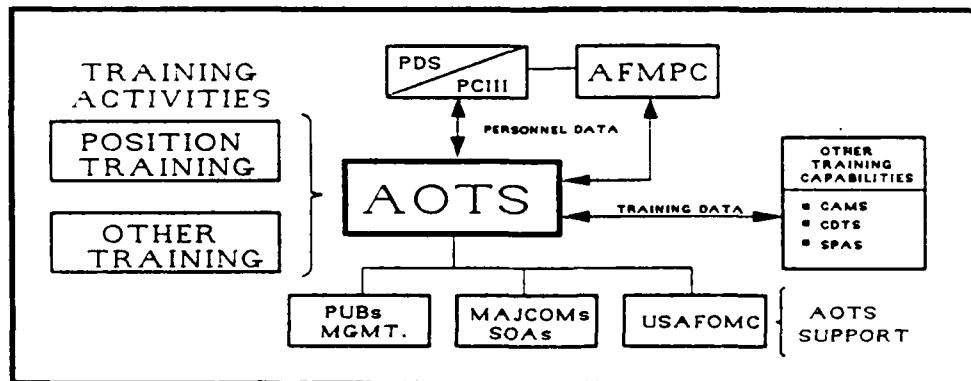

Figure 2-2 AOTS External Interfaces

2.5 AOTS Requirements/Functions and the Subsystems Matrix

The AOTS requirements have been matched up to each of the subsystems. Table 2-1 provides an cross reference matrix of the AOTS requirements and functions to each of the five subsystems in AOTS.

REQUIREMENTS	PRINCIPAL FUNCTIONS PERFORMED BY THE AOTS					BENEFITS
	MANAGEMENT SUBSYSTEM	EVALUATION SUBSYSTEM	COMPUTER SUPPORT SUBSYSTEM	COMPUTER ASSISTED TRAINING SUBSYSTEM	PERSONNEL AND SUPPORT SUBSYSTEM	
OJT Administration	Accurately identifies training for full position qualification		Provides automated training identified support, keeps training records		Identifies training requirements for system managers and users	Redirects OJT from general career development to specific position qualification. Relieves supervisor of administrative documentation burden.
OJT Management	Manages learning activities and controls progress, schedules training and manages resource allocation.		Provides automated support for prioritizing training requirements.			Efficiently employs "big picture" resource and training program management. More accurate capacity estimates.
Training Evaluation/Assessment		Identifies, selects, and delivers evaluation instruments.	Provides on-line delivery, support off-line delivery, keeps evaluation and assessment records.			Enables more frequent task proficiency evaluations and unit training effectiveness assessments to ensure quality training.
System Evaluation		Performs QA and System evaluation.	Collects, stores, calculates, and delivers reports.			Enables system quality assurance and reliability checks.
Data Automation Support			Provides integrated data processing support for subsystems			Provides user-friendly single-source support.
Specification of AOTS Operational Requirements					Identifies personnel and organizational requirements for AOTS. Identifies implementation, operation, and expansion requirements.	Provides for overall transition and expansion of the operational system.
Development of Evaluation and Training Materials		Identifies and develops task-specific evaluation instruments.	Supports development. Stores materials.	Develops task-specific evaluation and training materials.		Provides needed training materials/devices with efficient balance between centralization and decentralization.
Delivery of Evaluation and Training Materials		Delivers on and off line evaluation instruments.	Delivers materials and tests. Records response/progress.	Provides training on-line or prints for off-line use.		Employs new technology and efficiencies in training techniques.

Table 2-1 Requirements/Functions Cross Reference Matrix

3 SCOPE

3.1 Scope of the Operational Guide

This Operational Guide explains how the prototype AOTS will be integrated into the on-the-job training programs of those operational workcenters selected to participate in the SLT&E. It defines the users of the prototype AOTS. It outlines user responsibilities in developing, conducting, receiving and managing on-the-job training within the applicable functional areas and workcenters; and for operating and maintaining the prototype AOTS. Further, it explains how automation will support the specific processes associated with providing on-the-job training.

3.2 Participating Organizations and Air Force Specialties (AFSs)

Operational workcenters from all Air Force components (Active, Guard and Reserve) will be participating in the SLT&E. Figure 3-1 defines the principal participants and the development command (AFSC). AOTS, a program sponsored by AF/DPP, was given over to AFSC (in turn to HSD and AFHRL) with TAC, AFRES, and ANG being the test participants. Active and Reserve organizations are located at Bergstrom AFB, TX and the Guard organizations are located at Ellington ANGB, TX. Additionally, civilian contractors are assisting the Air Force. The organizations and units that participate in the SLT&E of the prototype AOTS are listed in Figures 3-2.

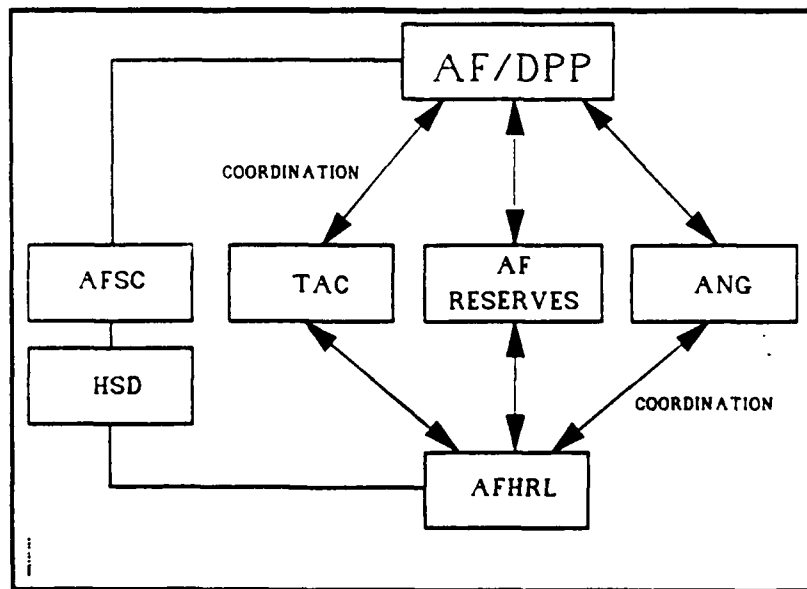

Figure 3-1 The AOTS Air Force Major Participants and Commands

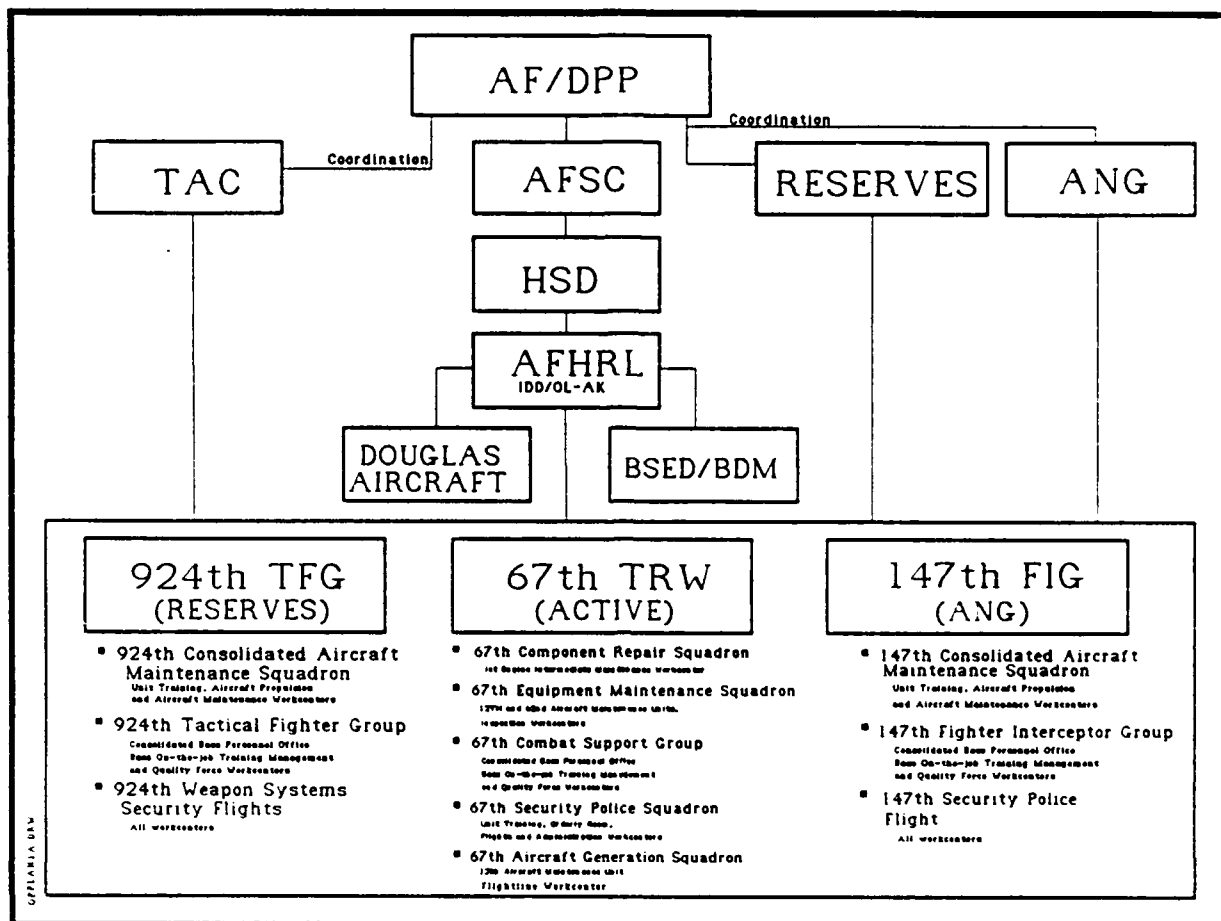

Figure 3-2 The AOTS Participants

3.3 Background

In the Air Force environment enlisted skills are acquired and maintained primarily through on-the-job training. The increasing complexity of weapon systems and equipment, the loss of qualified middle management personnel, and increasing mission demands have made job-site training more difficult to conduct. An increase in attention to training effectiveness and efficiency has surfaced indications of serious problems within the on-the-job training system. As an initiative to formally address problems, the Air Staff requested that AFHRL conduct a study of the on-the-job training system (Stephenson, R.W. and Burkett, J.R., *On-the-Job Training in the Air Force: A Systems Analysis*, AFHRL-TR-75-83, December 1975). Subsequent to the AFHRL study the Air Staff requested the Air Force Inspector General perform a Functional Management Inspection (FMI) of the on-the-job training system (The Air Force Inspector General Functional Management Inspection (FMI) of On-the-Job Training in the Air Force, PN 76-269, April 1977). Findings during the study and the FMI indicated the need for specific improvements within the system. These findings/recommendations are reflected in Figure 3-3 and along with subsequent actions.

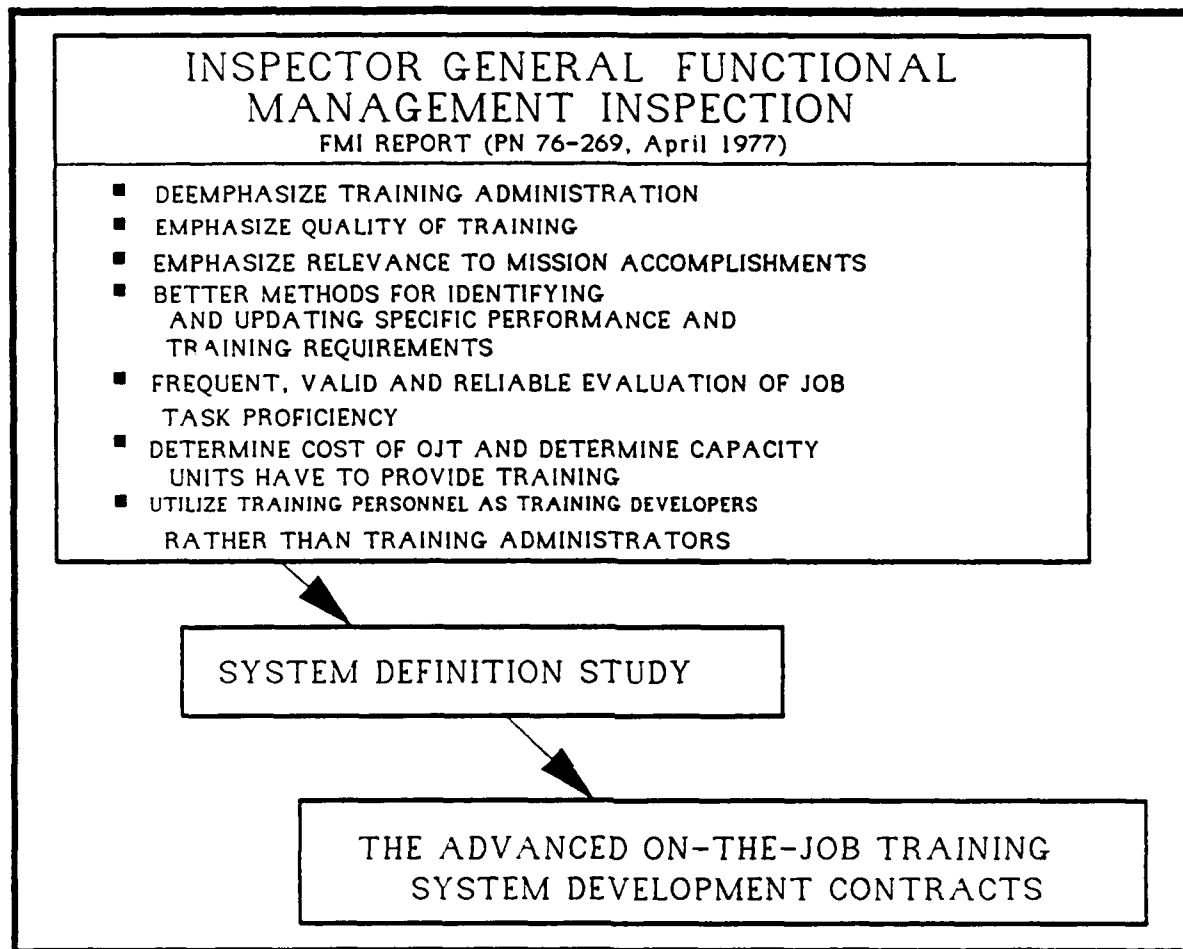

Figure 3-3 Inspector General's Findings/Recommendations and Subsequent Actions

3.3.1 System Definition Study

Subsequent to the AFHRL study and the FMI the Air Staff developed initiatives aimed at correcting the identified deficiencies. The ultimate initiative was to develop and test a prototype training system. The Air Staff specified that the prototype AOTS would be developed and tested within the actual operational environment. This initiative included determining the feasibility of applying automation within the on-the-job training environment. The first step toward developing a prototype training system was to conduct another study which was to result in:

- a) The definition of the Air Force on-the-job training system functional requirements;
- b) the determination of how automation could be applied to improve training system effectiveness and efficiency;
- c) a documented system description; and

- d) a determination as to which Air Force site was best suited as the location for developing and testing the prototype AOTS.

A contract was awarded to the Science Applications International, Corporation to assist the AFHRL in accomplishing the study. The results of this study are documented in an AFHRL Technical Paper (AFHRL-TP-83-54), entitled "Integrated Training System for Air Force On-The-Job Training: Specification Development", dated March 1984.

3.3.2 Design and Development of the Prototype AOTS

In August 1985 a three-phase contract for the design and development of the prototype AOTS was awarded to the Douglas Aircraft Company. The time periods for these phases can be found in Figure 1-1. The requirements of Phase I were to develop a preliminary design for the AOTS and each of its subsystems, to produce written functional specifications for the AOTS and its subsystems, and to produce written software specifications for each subsystem. The requirements of Phase II were to develop the detailed design for the subsystems, to develop the required software packages, to acquire the computer hardware to be used within the workcenters participating in the SLT&E, and to make all preparations necessary for the SLT&E to occur. Phase III is for the SLT&E of the prototype AOTS.

4 THE OPERATIONAL ENVIRONMENT AND USERS OF THE PROTOTYPE AOTS

4.1 The Operational Environment

Figure 4-1 lists the organizations, units, and workcenters participating in the SLT&E of the prototype AOTS. The environment in which the prototype AOTS has been developed, and will be tested, was selected because it is representative of the typical Air Force operational environment. The AFSs selected (see Figure 4-1) represent the largest and most diverse in the Air Force, and encompass various types of disciplines. The missions performed by these AFSs at the chosen locations are representative of the missions performed at most Air Force locations. Developing and testing the prototype AOTS in a representative operational environment enables a valid assessment as to whether or not the system is sufficiently flexible to accommodate the requirements within all functional areas.

4.2 Users of the Prototype AOTS

Figure 4-1 reflects the types of users of the AOTS and the development/support personnel. This section of the Operational Guide defines the functions to be performed by these users and the types of interactions with the prototype AOTS when the functions are supported by automation. The functions performed within the conventional on-the-job training system will continue to be performed within the prototype AOTS. However, the methods for accomplishing these functions have been greatly simplified. Additionally, new functions are required, which serve to improve the quality of training.

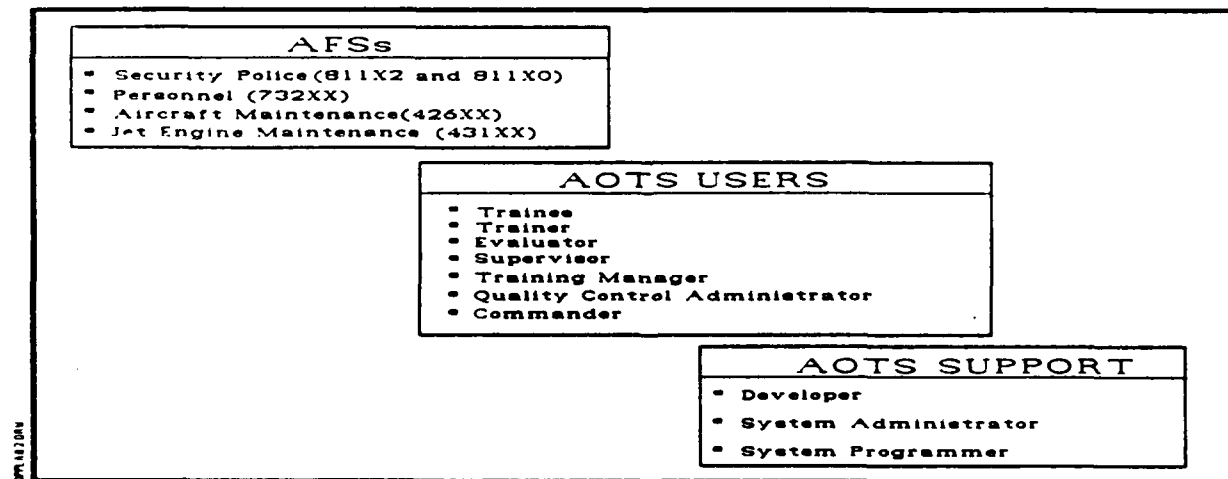

Figure 4-1 The Operational Users

4.2.1 Trainee

This type of user is the targeted recipient of training provided within operational workcenters. Each enlisted person assigned to the workcenters participating in the SLT&E of the prototype AOTS is a potential trainee. Only those persons who are fully position qualified and who do not require other training during the entire period of the SLT&E will be exempted from this category. Where trainees are currently required to research manual forms to determine their training requirements and progress status the AOTS will provide, on line, a complete history of those AFS tasks which have been certified and other training accomplishments, and the status of all training underway. Within the AOTS the status of training progress will include event level data (i.e. knowledge training, knowledge evaluation, performance training, performance evaluation) for AFS tasks. Additionally, trainees will be able to identify and access materials that are available for knowledge training and knowledge testing. These capabilities will enable trainees to take advantage of unscheduled training opportunities.

4.2.2 Trainer

This type user interacts with a trainee to teach him/her the knowledge, skills, and performance associated with specified tasks. When a trainee is assigned tasks for training the workcenter supervisor selects from within the same workcenter the person who is best qualified to teach the applicable tasks, and designates that person as the trainer. When selected as a trainer a person is provided capabilities to:

- a) review the on-line records of the trainee to determine the training requirements and the status of progress;
- b) review the task records to determine the subtasks, activities, supporting knowledge and skills and other task elements, the sequences in which training must be accomplished, and the resources required for task performance;
- c) review the behavioral objectives written for the tasks to determine the required outcomes, the materials available to support knowledge training, and resources required for training; and
- d) schedule training events.

4.2.3 Evaluator

This type user interacts with a trainee to either administer a written knowledge test or to observe and rate trainee performance of a task. The process for selecting an evaluator is the same as that for a trainer. An evaluator is given access to the same system capabilities as a trainer, plus an evaluator is given access to evaluation materials to be used off line.

4.2.4 Supervisor

This type user is the individual within an operational workcenter who is responsible for ensuring that training programs are properly planned and executed, and records of trainee progress and qualifications are accurately maintained. This user is provided with capabilities to:

- a) review training records of all personnel supervised;

- b) develop lists of position requirements;
- c) prioritize training requirements;
- d) schedule training and evaluation events;
- e) review task records;
- f) review behavioral objectives;
- g) obtain test materials for off-line use;
- h) certify trainee qualifications; and
- i) request trainee progress and system effectiveness reports.

4.2.5 Training Manager

This user is responsible for assisting supervisors in the development of effective training programs and providing overall management for training programs at the unit level (Squadron, Detachment) or higher levels (Deputy Commander for Maintenance (DCM) Training Management, Consolidated Base Personnel Office (CBPO) On-the-Job Training Management). This user is provided with capabilities to:

- a) review the training records of all personnel assigned to the organizations for which he/she is responsible;
- b) review all training requirements for these personnel;
- c) schedule training and evaluations for these personnel;
- d) obtain test materials for off-line use; and
- e) request trainee progress reports and training effectiveness reports.

4.2.6 Quality Control Administrator

This user (who may also be a Training Manager) will perform all functions associated with administering Quality Control Evaluations. He/she will assess the effectiveness of the automatic on-line process within the prototype AOTS that selects and schedules Quality Control evaluation events, and initiate changes as required. He/she will also schedule events that must be generated based on off-line requests. To schedule a requested event requires the Quality Control Administrator to interact with the prototype AOTS to:

- a) select the task to be evaluated;
- b) select the person to be evaluated;
- c) select the primary and alternate evaluators; and

- d) specify when the event will occur.

4.2.7 Commander

This type user is not envisioned to interact directly with the prototype AOTS. However, commanders will be provided reports generated from the system for use as management tools in ensuring effective training programs are established within all applicable workcenters.

4.2.8 AOTS Support Personnel

There is a class of users that support the operation of AOTS and have developed the software, and training and evaluation materials. All of these users are from AFHRL. These users are defined in this section.

4.2.8.1 System Administrator

This type of user has responsibility for general control and administration of functions within the prototype AOTS. This includes establishment of final Master Task Lists (MTLs), ensuring personnel added to the system are within the approved workcenters and AFSSs, assignment of personnel to a supervisor, and other general functions.

4.2.8.2 Developer

This type of user has responsibilities for analyzing performance requirements, writing terminal and supporting behavioral objectives, writing symbolic test items, writing Oral Test Guides (OTGs), writing Performance Evaluation Checklists (PECs), developing knowledge and performance tests, and developing computer-assisted instruction. The system will provide this user with capabilities to:

- a) enter the results of task analysis on line;
- b) author and store behavioral objectives on line;
- c) author and store test items on-line;
- d) create tests on line for both on-line and off-line use; and
- e) author computer-assisted instruction on line.

4.2.8.3 System Programmer

This type of user is responsible for the software maintenance for the prototype AOTS and in this role will have a very broad access level to allow problem identification, isolation, and correction.

5 DEVELOPMENT OF TRAINING MATERIALS FOR THE PROTOTYPE AOTS

Subject Matter Experts (SMEs) assigned to the AFHRL have been given responsibilities for the development of all training materials required during the SLT&E of the prototype AOTS. These responsibilities and functions are shown in Figure 5-1 under the Development Team box. Measures have been taken to ensure that the principles of Instructional Systems Development (ISD), as defined in applicable Air Force directives, are applied during all development efforts.

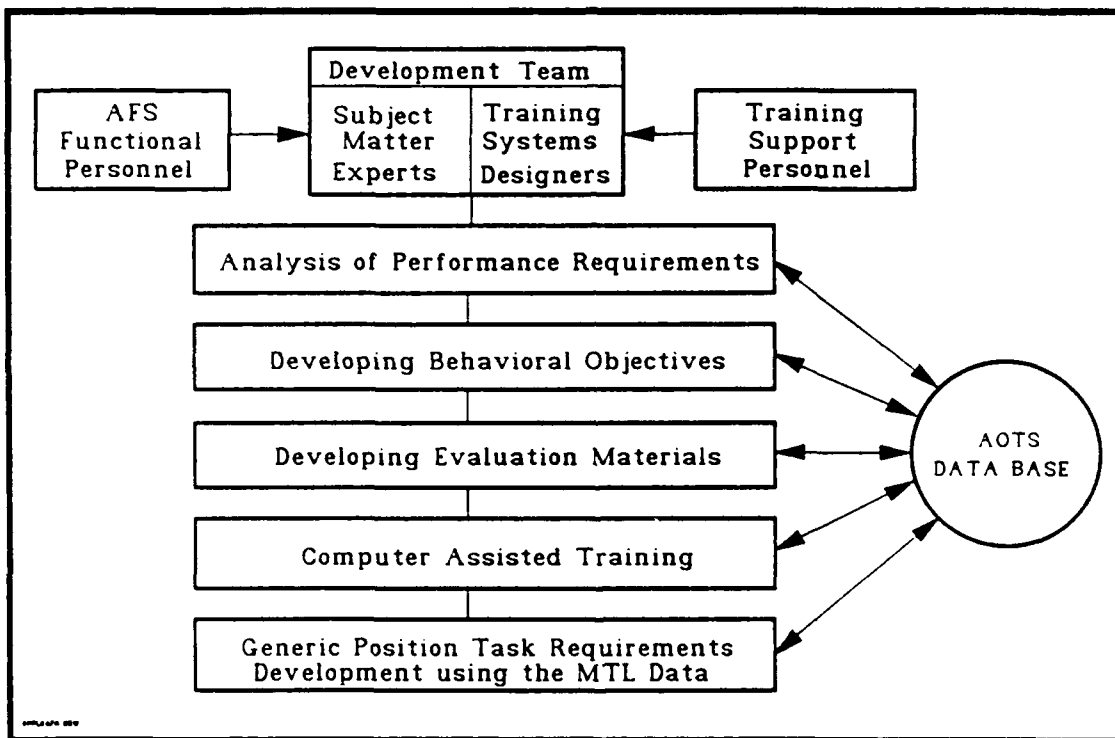

Figure 5-1 Development Functional Sequence

5.1 Analysis of Performance Requirements

The first accomplishment during development was the analysis of performance requirements. This analysis occurred off line, and included the definition of the task hierarchy (see Table 5-1), the preliminary development of task lists, the coordination of these task lists with the participating workcenters to all ensure requirements were identified, and the breaking down of tasks into task elements. The results were entered into the AOTS MTL task records using the MTL Editor. This editor enables the storage, within each task record, of those task elements reflected in Figure 5-2.

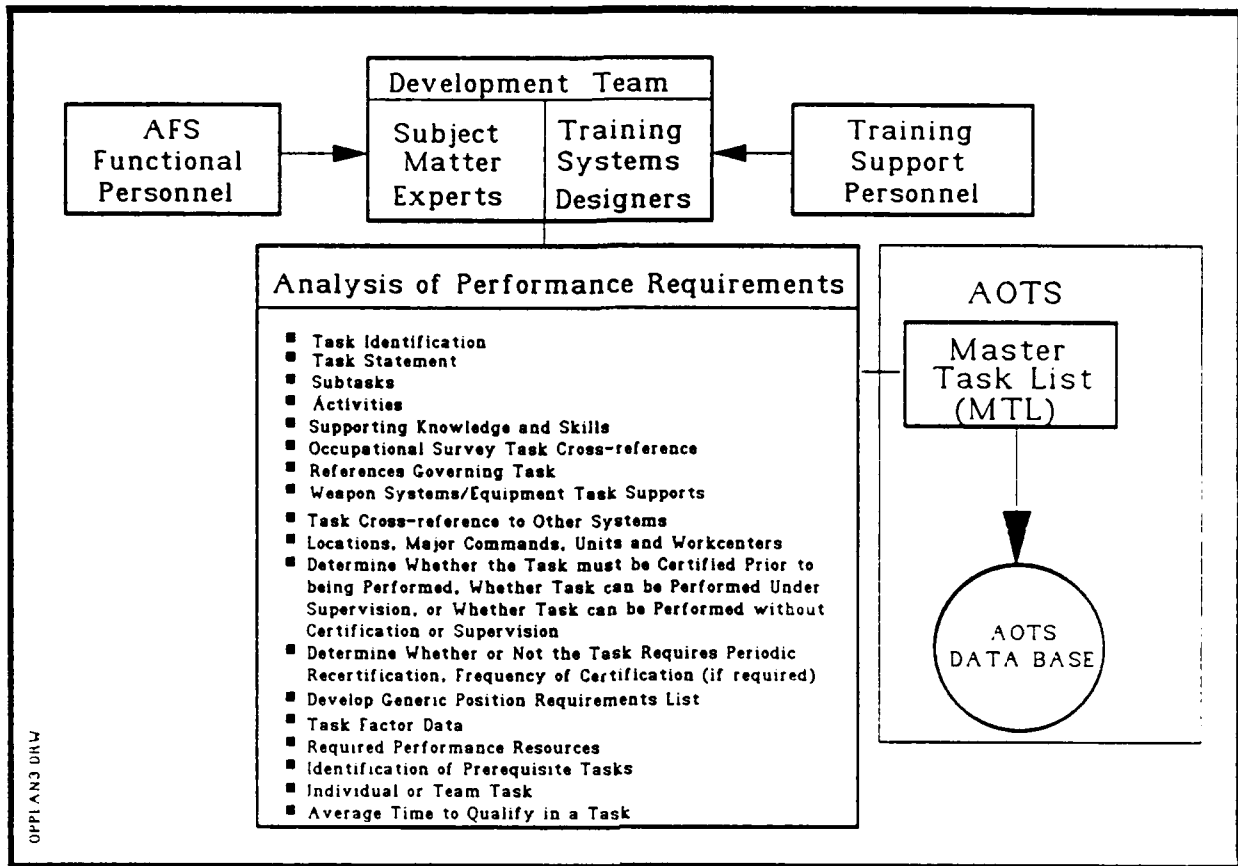

Figure 5-2 Analysis of Performance Requirements

FUNCTION	DESCRIPTION
JOB	The collective duties and tasks performed by a person.
DUTY	A segment of a job that is made up of similar tasks.
TASK	A part of a duty; a specific action, with an objective and an action verb, having a definite beginning and an end, resulting in something being accomplished; an observable and ratable action independent of other actions under the duty.
SUBTASK	A major part of the task; has the same characteristics as a task, but depends on other subtasks for task completion.
ACTIVITY	A step within a task or subtask that must be accomplished in order to perform the task or subtask; <u>THE LOWEST LEVEL OF PERFORMANCE ACTION ASSOCIATED WITH A TASK.</u>
SUPPORTING SKILL/ KNOWLEDGE	A physical or mental capability required to perform a task or subtask.
PREREQUISITE TASK	A task that must be completed prior to, or during performance of, the current task.

Table 4-1 Performance Hierarchies

5.2 Developing Behavioral Objectives

The prototype AOTS provides an editor for use in authoring and storing Terminal and Supporting Behavioral Objectives (BOs). Terminal BOs are developed at the task level and Supporting BOs are developed at the subtask level. This editor provides both a novice and an expert authoring mode. The novice mode prompts the user to author the three components (behavior, conditions, standard) of a BO independently, then create the narrative BO statement by combining the components. The expert mode permits the user to bypass the independent authoring of BO components and directly author a complete narrative BO statement. This editor also permits the user to identify the resources required for training and evaluating the BO, and the materials available for providing requisite knowledge training. The BO elements stored via the BO Editor are reflected in Figure 5-3.

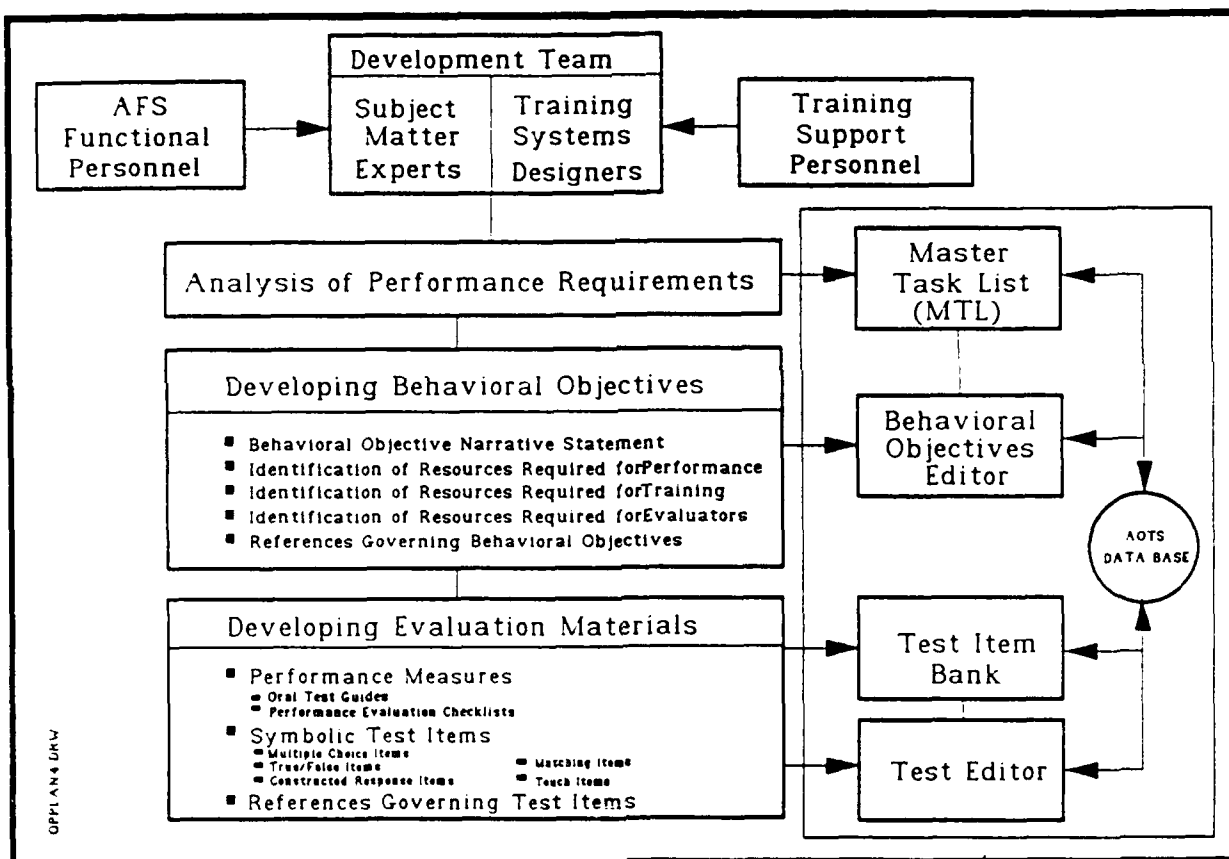

Figure 5-3 Development of Behavioral Objectives and Evaluation Materials

5.3 Developing Evaluation Materials

The next step following the authoring of BOs was the authoring of evaluation materials. First, the evaluation strategies to be used for each BO had to be determined. This determination was made off line. The evaluation strategies considered included:

- a) over-the-shoulder observation;

- b) product assessment; and
- c) symbolic testing.

To support the authoring of evaluation materials the AOTS provides a Test Item Bank (TIB) Editor. This editor permits the authoring and/or storing of the elements shown in Figure 5-3.

5.4 Developing Tests

Following the authoring of test items, the SMEs formulated tests for each BO. The AOTS provides a Test Editor for use in formulating tests. When a performance test is being developed, the test editor allows one or more OTGs and PECs, developed for those BOs applicable to the task, to be included. This capability enables the testing of one or more BOs for a task, using a single test. When developing a test to be used for measuring requisite knowledge the test editor enables the user to develop instructions for both on-line and off-line use of the test. Also, test items developed for one or more of the BOs applicable to the task can be designated for inclusion in the test. Again, this capability permits the testing of one or more BOs for a task, using a single test.

5.5 Developing Instruction

SMEs from each AFS team were designated to author Computer Assisted Training to support the training of requisite knowledge requirements for selected tasks (Figure 5-4). The process developed, and employed, for determining the tasks for which CAI would be developed included:

- a) Establishing criteria against which the tasks would be rated
- b) Assigning weights to the criteria
- c) SMEs rating each task based on how each criterion was met
- d) Multiplying each rating by the weight assigned to the criterion
- e) Summing the products for each task and rank-ordering the tasks based on their total scores.

CAI was developed for as many tasks as time permitted prior to the start of SLT&E. SMEs developed instruction on line using the Air Force owned Instructional Support System (ISS). Interfaces between the AOTS and the ISS have been developed to enable the on-line delivery of instruction to trainees.

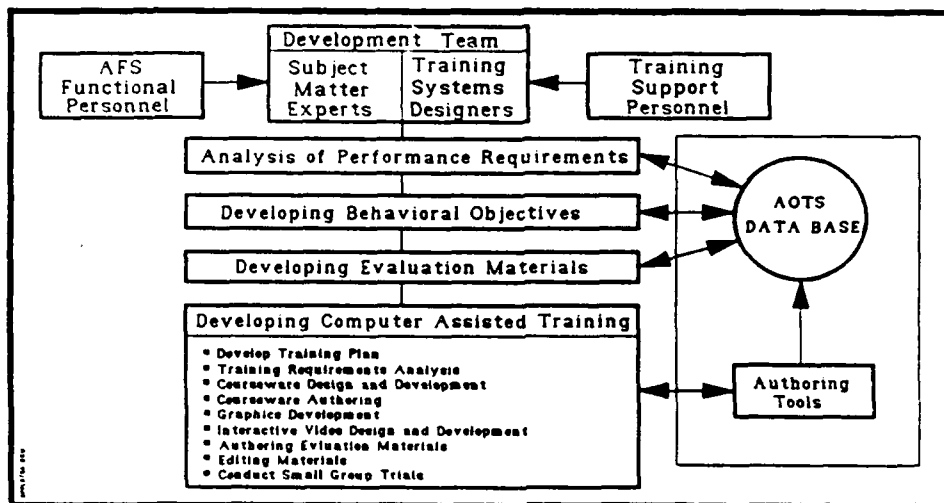

Figure 5-4 Computer Assisted Training Development Sequence

5.6 Developing Generic Position Task Requirements (GPTR) Lists

The final requirement in the development effort was to generate a GPTR list for each type of duty position to be included in the SLT&E of the prototype AOTS. The process for generating a GPTR is presented in Figure 5-5. A GPTR list is comprised of those tasks that are normally performed by airmen assigned to a specific type of duty position. The purpose for a GPTR is to provide the baseline for the development of an Operational Position Task Requirement (OPTR) list. An OPTR list contains the specific tasks and other training requirements associated with a specific duty position, and is tailored to the airman assigned to that duty position. The prototype AOTS provides a capability to merge a GPTR list into an OPTR list, which negates the need for immediate supervisors to specify for inclusion in the OPTR list those tasks that are already contained on the GPTR list. A detailed description of how an OPTR is generated is contained in Section 6.

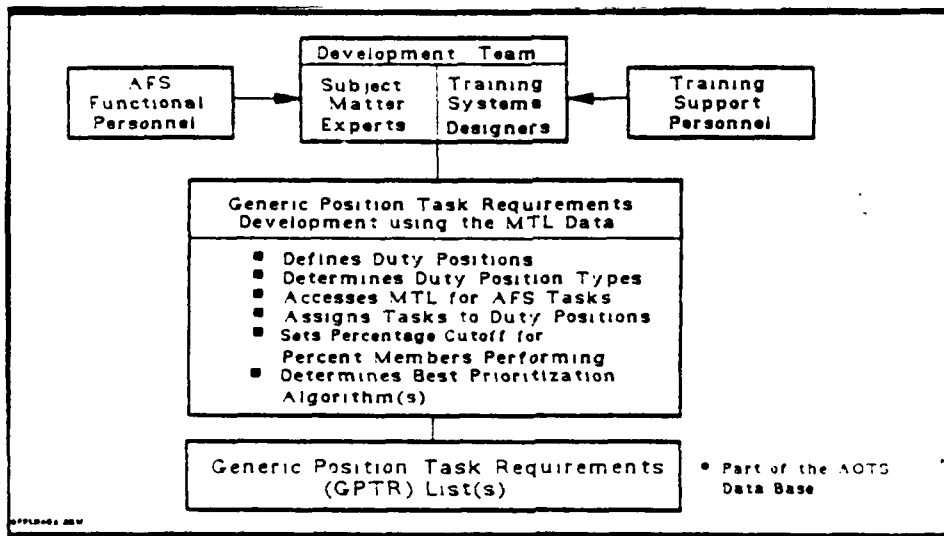

Figure 5-5 GPTR Development

6 USING THE PROTOTYPE AOTS IN THE OPERATIONAL ENVIRONMENT

The following describes how the prototype AOTS supports the training functions performed within an operational unit. The description starts with a trainee being assigned to a duty position within a workcenter, proceeds through the planning and execution of a training program for that airman, and ends with the trainee becoming duty position qualified. Included are explanations of how users interact with the prototype AOTS. Figure 6-1, The Airman Training Record Categories and Figure 6-2, Training Process are provided to help illustrate training actions that occur within an operational unit.

6.1 Assignment of a Trainee to a Workcenter

One of the first actions to be taken when an airman is assigned to a workcenter designated to participate in the SLT&E of the prototype AOTS is to create an automated Airman Training Record (ATR) for that airman. An ATR will normally be created by the unit training manager through use of the ATR Editor. There will be an exception for personnel assigned to the participating workcenters prior to the start of SLT&E in that their ATRs will be created by the AFHRL SMEs. This action is necessary to ensure the availability of their ATRs on the first day of the SLT&E period. The ATR contains nine separate categories of data. These categories are listed in Figure 6-1. Appendix A contains computer screen representations of the ATR. Review of this material is helpful in understanding how various users interface with the system.

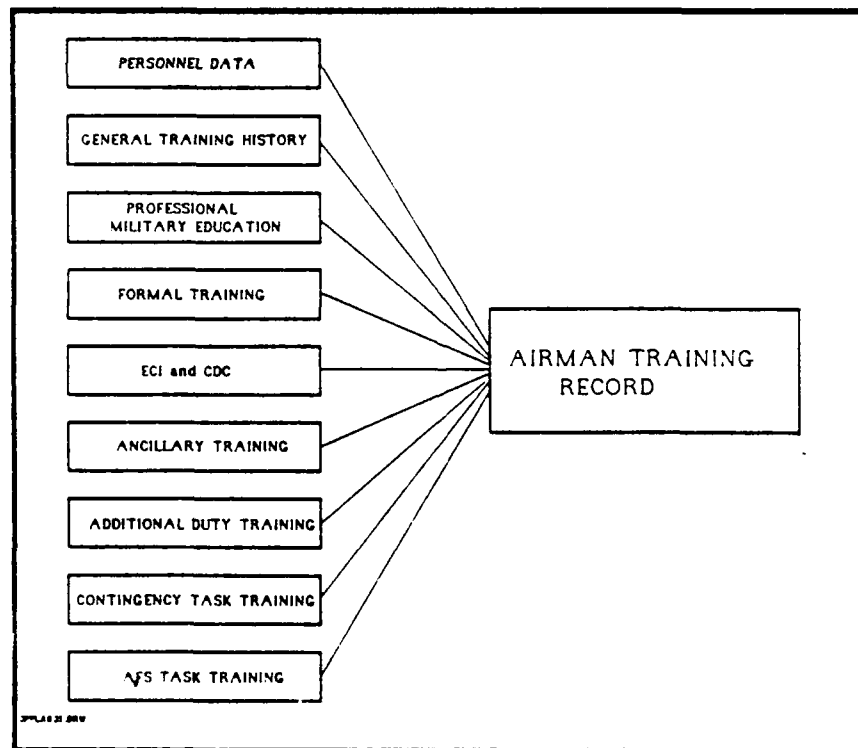

Figure 6-1 The Airman Training Record Categories

The actions assigning an airman to a workcenter include reporting the airman as being assigned to a specific duty position. This action is coordinated with the unit orderly room. Duty positions are identified by duty position numbers which are reflected on Unit Manning Documents (UMDs). The duty position number is significant to the next action, which is to identify the tasks to be performed and courses to be completed by the airman while assigned to that duty position. The immediate supervisor of the airman identifies the tasks to be performed and the courses to be completed by the airman either through selecting an existing Operational Position Task Requirements (OPTR) List for the duty position and modifying the list, if deemed necessary, or through creating a new OPTR List (see Figure 6-2). The identification number of the OPTR List will be the same as the applicable duty position number contained on the UMD. By using the duty position number as the OPTR List identification number, cross referencing the two entities is simplified. It is often necessary to assign more than one airman to the same duty position number. If the performance requirements for those airman are different it becomes necessary to create more than one OPTR List for that duty position. Space is provided at the end of the OPTR identification number where a numerical code can be entered to distinguish between OPTR Lists for the same duty position. An OPTR List is created through the OPTR Editor.

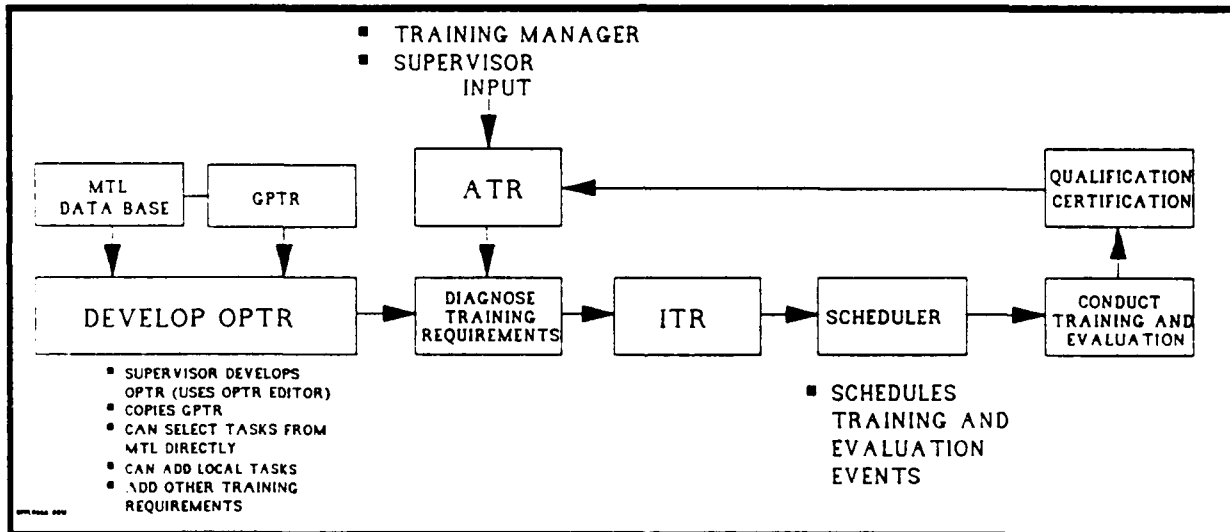

Figure 6-2 Training Process

The first step in creating an OPTR List is to select a Generic Position Task Requirements (GPTR) List for the type of duty position to which the airman has been assigned. (A GPTR List identifies the tasks performed by all persons assigned to the same type of duty position, e.g. the tasks performed by all Aircraft Crew Chiefs within Air Force Specialty Code (AFSC) 431X1. GPTRs are developed by the AFHRL SMEs.) Subsequent to selecting the appropriate GPTR List the immediate supervisor commands the AOTS to copy that GPTR List to the OPTR List. The GPTR List then becomes the baseline for the OPTR List. The immediate supervisor may then delete those tasks from the OPTR List that will not be required for the airman.

The next step is for the immediate supervisor to review the MTL for the applicable AFS (if deemed necessary) to determine if tasks exist that should be added to the OPTR List. If it is determined that tasks on the MTL are required then the immediate supervisor commands the AOTS to copy the tasks from the MTL to the OPTR List. If an immediate supervisor discovers that the MTL does not contain an AFS task that is

required to be performed by the airman the capability to enter the statement for that task into a temporary AOTS file will be provided. The requirement will be flagged to the AFHRL SMEs who will take appropriate development actions.

The next step is to add other tasks or courses to the OPTR List that have been designated as required for all airmen assigned to the specific duty position. The categories of other possible requirements include Ancillary Training courses, Additional Duty Training courses, and Contingency Tasks. Requirements within these categories that have been specified for the duty position will have already been identified within the AOTS data base by AFHRL through use of the Other Training Requirements (OTR) Editor. Any requirements within these categories that have been specified for the duty position will automatically be moved to the applicable OPTR List upon command.

Subsequent to completing the OPTR List the immediate supervisor will command the AOTS to perform an automatic training diagnosis process. This process compares the OPTR List to the airman's ATR to determine if the airman requires training in any of the tasks and courses. If any training is required the AOTS produces an Individual Training Requirements (ITR) List reflecting each requirement. For each AFS task reflected the AOTS assumes that four events are required:

- a) Knowledge Training;
- b) Knowledge Evaluation;
- c) Performance Training; and
- d) Performance Evaluation.

For Ancillary Training courses, Additional Duty Training courses, and Contingency Tasks the AOTS assumes that *only one training event* is required for each. For Extension Course Institute and Career Development courses the training manager or immediate supervisor may establish an event for each volume within a course and up to two events for the course examination and a possible retake.

Following the generation of the ITR List the immediate supervisor may use the ITR Editor to add other requirements to the list which are to be completed by the airman. Other requirements in the categories of Ancillary Training, Additional Duty Training, Contingency Tasks, and Extension Course Institute and Career Development Courses will be checked for validity within the AOTS whenever attempts to add them to an ITR are made (these requirements must have been defined within the AOTS data base as Air Force approved requirements). Requirements within the Formal Training and Professional Military Education categories will not be checked for validity by the AOTS when added to an ITR. (To acquire the computer space that would be necessary to store data for the volume of courses within these categories, and to add the manpower that would be necessary to maintain course data currency, would not be cost effective for the prototype AOTS.) Since the system does not check for validity of the requirements within these categories immediate supervisors will not be restricted by the types of requirements that can be entered. This should be beneficial when identifying and managing requirements such as training provided at manufacturers facilities, other formal training, or unique local training. Following the identification of requirements the immediate supervisor will identify the person(s) appointed to train and evaluate the airman on AFS tasks. This will be accomplished through entering the social security number(s) of the designated person(s) into the space provided.

The prototype AOTS features a qualification assessment program. The purpose of this program is to assist workcenter supervisors in selecting airmen to be assigned to duty positions. This program compares an airman's qualifications to duty position requirements. Through this capability immediate supervisors are able to determine:

- a) An airman's qualifications for a single duty position
- b) An airman's qualifications for multiple duty positions
- c) The qualifications of multiple airmen for a single duty position
- d) The qualifications of multiple airmen for multiple duty positions.

The prototype AOTS will identify, and list, those requirements which would have to be trained should airmen be assigned to specified duty position(s). This feature will enable immediate supervisors to assign airmen to duty positions based on who is most qualified, and who would require the least amount of training to become position qualified.

6.2 Planning Training

After the immediate supervisor has identified on an ITR List all training requirements for an airman a training plan must be developed. Developing a training plan means to determine the sequence in which requirements will be trained within each category. There are two methods by which AFS task training requirements on an ITR List can be sequenced. First, the tasks are rank ordered in the same sequence as that on the OPTR. This process is automatic in that the rank order is carried forward from the OPTR. The second method is for the immediate supervisor to sequence the training requirements through interfacing with the ITR Editor. When tasks on an ITR are rank ordered using the second method the automatic rank ordering capability is lost for that ITR. The second method will be most advantageous when immediate supervisors desire to sequence training requirements to correspond with known training opportunities or to meet with established schedules for on-going training. Training requirements within all categories other than AFS Tasks will be sequenced by the immediate supervisor.

6.3 Scheduling Training Events

After identifying training requirements, training events are scheduled using the AOTS Scheduler. Training events may be scheduled by the immediate supervisor or by the training manager. Schedules may be established for an individual airman or for groups of airmen.

The first step in establishing an event schedule is to select either the option to schedule an individual airman or the option to schedule a group of airmen. If a schedule for an individual airman is to be established, the requestor may either enter the social security number of the airman for which the event is being scheduled or command the AOTS to display a list of the social security numbers for those airmen whose records the requestor may access. If a list of the social security numbers is displayed the requestor will then select the social security number of the airman to be scheduled. Next, the requestor must select the category of the requirement to be scheduled. The requirements within that category that have been entered onto the ITR List for the airman will be displayed. If the requirement being scheduled is within the AFS Task category the requestor will then be prompted to enter the date the training event is to occur, and the identification of the trainer for the requirement if different from the trainer identified on the ITR. Otherwise, the next step is to select the specific requirement to be scheduled. After selecting the requirement to be scheduled the requestor will be prompted to enter the dates and times that the event will start and finish, the agency conducting the training, and where the event will occur. Space is provided for entering remarks, if desired. Once these data are entered, an automatic search will be performed to determine if the airman has already been scheduled for an event during the same time frame. If the airman has been scheduled for another event during the same time frame, the requestor

will be so advised. The requestor must then decide whether to proceed with the schedule, or to schedule the event for a different time. If the requestor proceeds with the schedule and a scheduling conflict is created, then a determination must be made as to whether both events can occur within the same time frame or if the previously scheduled event should be rescheduled.

To schedule a training event for a group of airmen the requestor will first select the category of the requirement. Next, the requestor will enter the identification number for the specific requirement to be scheduled. The requestor will then indicate the quota for the event. The AOTS will then automatically identify, from those airmen whose records may be accessed by the requestor, those airmen who require the training. The AOTS will also identify the appropriate number of airmen who are most eligible to receive the training. Eligibility will be based on the relative position of the requirement on the airmen's ITRs. The requestor may either accept the AOTS produced listing of most eligible airmen to be scheduled for the event or interface with the AOTS Scheduler to substitute names of other airmen who require the training. Airmen who do not have the requirement included on their ITR may not be scheduled for an event. The requestor will be prompted to enter the dates, times, location, training agency, and remarks for the event in the same manner as when scheduling an event for an individual airman. When these data are entered into the AOTS the requestor will be advised of any conflicts in scheduling for the affected airmen. If conflicts are identified, the requestor must decide whether to allow the requested event to be scheduled within the same time frame as other scheduled events or to reschedule the event for all airmen who have a scheduling conflict.

Training event schedules will be printed and distributed to those personnel affected by the event. A schedule will reflect:

- a) the event sequence number;
- b) the requirement identification number;
- c) the title of the requirement; the names of the personnel to receive training;
- d) the dates, times, and location of the event;
- e) the agency conducting the training;
- f) any resources required to support the event; and
- g) any required instructions.

Immediate supervisors and training managers are also provided the capability to cancel scheduled events.

6.4 Conducting Training

After training event schedules have been established and distributed the next thing to occur is the actual conduct of training. For the most part, job-site training under the purview of the prototype AOTS will be delivered in the same way that it is in the current system. Immediate supervisors or other designated personnel will be responsible for teaching airmen the required knowledge and skills required to achieve proficiency in AFS tasks. Ancillary Training, Additional Duty Training, and Contingency Tasks will be taught by agencies outside of the work areas. Completing required Career Development Courses will be the responsibility of the individual airman. However, the prototype AOTS supports the conduct of training for AFS tasks through providing data resulting

from task analysis that are not readily available in the current system. Included within each task record are the steps to be accomplished within the task. These steps appear in the sequence in which they are performed. These data serve as a training outline. In addition, the identification of publications that contain information about the task, the resources required to perform the task, the knowledge and skills required for task performance, and the identification of prerequisite tasks are listed. Further, the behavioral objectives that have been developed for the task are stored within the task record as well as a list of resources required for training each objective, and a list of materials available for providing knowledge training for each objective. These may either be displayed on line or printed for off-line use.

There is an exception to training under the purview of the prototype AOTS being delivered in the same way as in the current system: the delivery of knowledge training for specific tasks. The preceding paragraph indicated that materials available for providing knowledge training for a behavioral objective are listed with that objective. These materials may include CAI (previously discussed in Paragraph 5.5), text, films, sound-on-slide packages, or other materials. If CAI materials have been developed for a behavioral objective, study of these materials must be completed by those airmen who must satisfy knowledge training requirements for that behavioral objective. When presented with an opportunity, an airman may elect to complete a knowledge training event. To accomplish this the airman may log onto the prototype AOTS, and then select from the menu options displayed on the screen those that permit training to proceed. The prototype AOTS will then perform a search of the airman's ITR and select the knowledge training event that should be trained next. If the event is a knowledge training event, and CAI materials are available for that event, then the airman will be presented the materials on line. The ITR search and event selection process includes:

- a) starting from the top of the ITR, searching for the first task having a knowledge training event that has been assigned for training, or that has been scheduled for training on the current or a past date, and selecting that event (assigned for training means the supervisor wants the task trained as soon as an opportunity is presented, but an event could not be scheduled due to the lack of resources, etc.); and
- b) if no event has been assigned, or scheduled on the current or a past date, then, starting from the top of the ITR, searching for the first task that has a knowledge training event reflected as not completed, and selecting that event.

If no event has been selected from this process and a task is found having a event scheduled for a future date, the process will be terminated. The purpose for terminating the process is to ensure that no training are evaluation is given out of the sequence established by the immediate supervisor. If a supervisor elects to have an event that has been scheduled for a future date start sooner, then he/she will be required to change the schedule to the current date. If no events can be selected, the airman will be so informed. No priority for behavioral objectives within tasks will be considered. The first incomplete event for any objective within the established sequence becomes the candidate to be trained next.

As indicated above, knowledge training materials can take many forms. If CAI materials have not been developed for an objective but other materials have been developed, then the airmen may elect to study whichever materials are available. Materials other than CAI materials will be completed off line. When an airman completes CAI materials the ITR will automatically be updated to show the corresponding knowledge training event as completed. When materials are taken off line airmen must inform the AOTS when study of the materials has been completed. This will be accomplished by responding to prompts.

Again, when training materials have not been developed for a behavioral objective ensuring that an airman acquires the required knowledge and skills is ultimately the responsibility of the immediate supervisor.

6.5 Evaluating Training

The prototype AOTS implements the Air Force Inspector General's recommendation to provide for more frequent, valid, and reliable evaluation of AFS task proficiency. This is accomplished by providing the capabilities to measure airmen acquisition of requisite knowledge, literacy requirements, and skills applicable to AFS tasks; and to evaluate airmen performance of AFS tasks. Certain Ancillary Training and Additional Duty Training courses and Contingency Tasks also require testing for completion. However, these will not be tested within the prototype AOTS, since the agencies responsible for administering these requirements are not participating in the SLT&E of the prototype AOTS.

The development of evaluation materials to be used within the prototype AOTS to measure requisite knowledge, skills, and performance was previously discussed in Paragraph 5.3. These evaluation materials may be used for both pre-training testing and for post-training testing. Testing prior to conducting training is accomplished when it is necessary to:

- a) determine if an airman already possesses the knowledge and skills required to perform a specific task, or is capable of performing that task; or
- b) determine where training on a specific task should start should an airman not possess the knowledge and skills required to perform a task, or be incapable of performing that task.

Testing an airman after training has been conducted is necessary to determine if the airman has acquired the knowledge and skills required to perform a specific task, or is capable of performing the task. The results of post-training tests are also analyzed to determine the validity, comprehensiveness, and effectiveness of both the training and the tests.

To understand how evaluation materials are to be used within the prototype AOTS requires an understanding of the task hierarchy and of behavioral objectives. These are discussed in Paragraphs 5.1 and 5.2, respectively. Evaluation materials have been developed at the behavioral objective level. As stated in Paragraph 5.2 there are two types of behavioral objectives used in the prototype AOTS:

- a) Terminal Behavioral Objectives, which correspond to tasks; and
- b) Supporting Behavioral Objectives, which correspond to subtasks.

Generally, two types of tests are developed for terminal and supporting behavioral objectives. These are:

- a) a knowledge test that is made up of instructions for administering the test, and of symbolic test items that measure requisite knowledge and task literacy (if required); and
- b) a performance test that is made up of instructions for administering the test, and of checklists that are used to rate observed performance or a completed product.

The exception to this is where symbolic tests must be used exclusively because task performance cannot be measured due to the infrequency of occurrence, etc. Decisions relevant to whether a task would be evaluated only at the terminal behavioral objective level, only at the supporting behavioral objective level, or at both the terminal and supporting behavioral objective levels were made as a part of determining evaluation strategies, which was discussed in Paragraph 5.3. All tests developed for a behavioral objective must be completed before that objective is considered to be completed. All behavioral objectives for a task must be completed before an airman is considered as eligible for qualification certification.

When an airman's ITR is updated to show that the knowledge training for a behavioral objective has been completed, the prototype AOTS will perform a search to determine if a knowledge test has been developed for that objective. If a knowledge test is available then the ITR will automatically be changed to show a requirement to complete the test. The same process will occur when an airman's ITR is updated to show that performance training for an objective has been completed. Knowledge tests will normally be taken on line. They may, however, be printed for off-line administration by an immediate supervisor, a training manager, or a designated evaluator. Performance tests used within the prototype AOTS will always be administered off line. An airman may be administered a knowledge test on line by going through the process outlined in Paragraph 6.4, if the event selected is a knowledge evaluation event.

6.6 Recording Trainee Progress

The status of airmen progression in AFS task events and other training requirement events is maintained on ITR lists. Status includes: required, assigned, scheduled, or completed. The history of AFS task certifications and the completions of other training are maintained in ATRs. These records were previously discussed in Paragraphs 6.1 and 6.2.

When training requirements are entered onto ITRs, and no other status is reflected, they are simply considered as required to be completed at some future time. When a requirement must be completed at the earliest possible opportunity, but an event(s) for the requirement cannot be scheduled, the responsible person should change the status of the event(s) to reflect assigned. When an event for a requirement is scheduled the status will be changed automatically to reflect scheduled. When an AFS task knowledge training event is completed on line the status will automatically be updated to reflect completed. When an airman studies knowledge training materials off line, and responds to system prompts that study was completed, the status of the corresponding event will automatically be changed to reflect completed. When knowledge training materials are not available to support a knowledge training event, the immediate supervisor is responsible to ensure the training is provided, and, therefore, should update the event when training is completed. Since all AFS task performance training events, and other training events, are conducted off line, these too should be updated by the responsible persons when training is completed. The status of knowledge evaluation events, when tests are administered on line and passed, is automatically changed to completed. The status of knowledge and performance evaluation events, when tests are administered off line, passed, and read into the system via optical mark readers, is automatically changed to completed. If the status of training and evaluation events that is not updated automatically is not maintained by responsible persons, then training progress cannot be correctly reported.

6.7 Performing Quality Control Evaluations

Another recommendation resulting from the aforementioned Functional Management Inspection (FMI), is to place more emphasis on the quality of training programs. Within the prototype AOTS, the quality of training programs within workcenters, units, and the training system as a whole, will be assessed on a recurring basis. This will be

accomplished through evaluating airman performance of AFS tasks after qualification has been certified, and providing data reflecting the evaluation results to appropriate managers. The evaluations are referred to as QC evaluations. Capabilities are provided to generate QC evaluation events automatically or manually.

The prototype AOTS features a program that will automatically generate QC evaluation events, at specified time intervals. The system will select the tasks to be evaluated, the airmen to be evaluated, and the evaluators. A task is selected only if performed at Bergstrom AFB or Ellington ANGB, and if the values for the task factors (percent of members performing and training emphasis) equal or exceed specified percents. An airman to be evaluated is selected only if he/she has been certified on the selected task within the past specified number of days, and if he/she has not been QC evaluated on the task previously. An evaluator is selected only if he/she has been certified as qualified on the task selected, is not the trainer of record, did not certify that the airman was qualified on the task to be evaluated, and, obviously, if he/she is not to be evaluated on the task. Once all selections have been made, the system will then automatically schedule the event, and generate a schedule for off-line distribution.

In instances where a commander, training manager, or supervisor wants a QC evaluation event generated for a specific task or airman, the QC administrator may interface with the prototype AOTS to make appropriate selections, and then to schedule the event. The QC administrator will be prompted to specify the identification number of the task to be scheduled, the social security number of the airman to be evaluated, the social security number of the evaluator, the time and place for the event, and enter instructions, if required.

6.8 Generating Training Reports and Notices

The quality of training under the purview of the prototype AOTS is further emphasized through the generation and distribution, to appropriate managers, of both standardized and ad hoc training effectiveness reports. Standardized reports reflect training progress data for workcenters, units, and the prototype AOTS as a whole. Ad hoc reports may be requested from the system administrator. The types of data to be included in ad hoc reports, and report formats, will be determined by the requestor. The system also generates notices of training actions required when changes in personnel status occur. These notices will be distributed to agencies responsible for actions. The types of standardized reports and notices produced from the system are reflected in Figures 6-3 and 6-4.

■ Unit Position Qualification Status Summary	■ Task Certification Expiring
■ Unit Upgrade Training Status Report	■ CDC Status Report
■ Workcenter Position Qualification Status Summary	■ Failed Quality Control Evaluation/Recommendation for Decertification
■ Workcenter Upgrade Training Status Summary	■ Test Requested for Off-Line Testing
■ Individual Position Qualification Status Summary	■ Unit Upgrade Training Roster
■ Individual Upgrade Training Status Summary	■ Base Upgrade Training Roster
■ Impacts Caused by Personnel Losses	■ Workcenter Upgrade Training Roster
■ Base Position Qualification Status Summary	■ Individual Training Notice
■ Base Upgrade Training Status Summary	■ CDC Enrollment
■ Test Item Analysis Results	■ CDC Completion
■ Base Training Resource Availability/Utilization	■ Local/New Task Follow Up Requirement
■ Training Event Schedule	■ Unit Training Event Status Summary
■ Training Event Completion	■ Base Evaluator Performance Summary
■ Training Event Cancelled	■ Unit Event Schedule Failure
■ Workcenter Training Event Status Summary	■ Base Event Schedule Failure Summary
■ Evaluation Event Schedule	■ Workcenter Task Coverage Summary
■ Training Development Cost Factors	
■ Trainer Performance Data	

Figure 6-3 Standardized Training Reports

- | | |
|-----------------------------------------------------------------------------------------------------------------------------------------------------------------------------------------------------------------------------------------------------------------------------------------------------------------------------------------------------------------------|-----------------------------------------------------------------------------------------------------------------------------------------------------------------------------------------------------------------------------------------------------------------------------------------------------------------------------------------------------------------|
| <ul style="list-style-type: none">▪ Change in DAFSC--New OPTR Required▪ Trainee TDY▪ PRP Disqualification▪ Projected Date of Separation (DOS)▪ Trainee Hospitalized▪ Trainee Released from Hospital▪ Trainee Performing Duty out of CAFSC (UGT)▪ Trainee Returned to Duty in CAFSC (UGT) | <ul style="list-style-type: none">▪ Trainee on Leave▪ Trainee Returned from Leave▪ Trainee is in an AWOL/Deserter Status▪ Trainee Returned to Duty from an AWOL/Deserter Status▪ Airman in Confinement▪ Trainee Performing Duty out of CAFSC (PQT)▪ Trainee Returned to Duty in CAFSC (PQT) |
|-----------------------------------------------------------------------------------------------------------------------------------------------------------------------------------------------------------------------------------------------------------------------------------------------------------------------------------------------------------------------|-----------------------------------------------------------------------------------------------------------------------------------------------------------------------------------------------------------------------------------------------------------------------------------------------------------------------------------------------------------------|

Figure 6-4 Personnel Change Notices

7 OPERATIONAL SUPPORT

The AFHRL/IDD/OL-AK AOTS program office, located at Bergstrom AFB,¹ will be providing full technical and management support to all AOTS participants during SLT&E. HRL will be providing direct and indirect support to all users. HRL is backed up by the prime development contractor, Douglas Aircraft Company, and the site management and integrator contractor team, Ball Corporation, Systems Engineering Division and BDM Corporation.

7.1 Problem Reporting

Problems encountered while using the prototype AOTS will be addressed and fixed by AFHRL. It is essential that all problems be brought to the attention of AFHRL. Routine types of problems can be handled by either a written request or by telephone. All emergency problems that will have an effect on a workcenter's training should be handled by telephone. AFHRL has set up a "hot line" telephone at Bergstrom AFB so that a user can call in problems at any time (day or night, weekends, etc.). A phone answering machine will be in operation when the IST and contractor personnel are away. Your problem will be answered as soon as possible when personnel return.

7.2 Hot Line Support

The hot line number is 369-HELP (AUTOVON number 8-685-HELP) or, if you are located on Bergstrom AFB, simply dial HELP (or 4357). Any problem, how to use, hardware, software, training materials, procedures, etc., are all referred to the hot line for fast service.

The regular AFHRL/IDD/OL-AK program management office number is AUTOVON 8-685-2667. The IST number (at building 1808) is 8-685-3070.

7.3 AFHRL/IDD/OL-AK AOTS Program Organization

Figure 7-1 provides an overview of the AFHRL AOTS program organization at Bergstrom AFB. The program chief is Major J. Blackhurst (IDD/OL-AK). The prime development contractor is Douglas Aircraft Corporation, a division of McDonnell Douglas Corporation and the site management and integrator contractor is a team headed by Ball Corp., Systems Engineering Division and BDM Corporation.

¹The AFHRL Operating Location at Bergstrom AFB, Texas, has been discontinued.

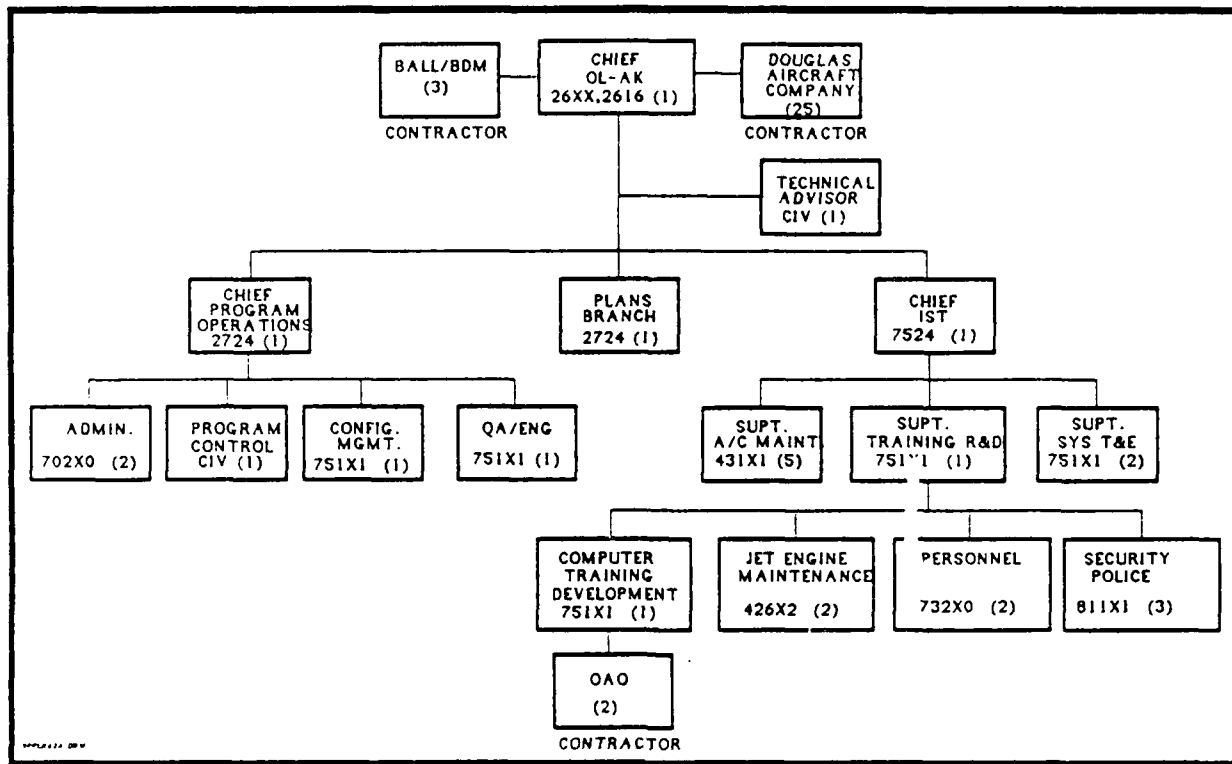

Figure 7-1 The AOTS Program Organization with AFHRL

8 GLOSSARY OF TERMS

ACRONYM	DEFINITION
A/C	Aircraft
AF	Air Force
AF/DPP	Air Force/Director Personnel Programs
AFB	Air Force Base
AFHRL	Air Force Human Resources Laboratory
AFHRL/IDD/ OL-AK	Air Force Human Resources Laboratory, IDD/OL-AK, AOTS branch within the laboratory operating at Bergstrom AFB
AFMPC	Air Force Military Personnel Center
AFRES	Air Force Reserves
AFS	Air Force Speciality
AFSC	Air Force Systems Command
AFSC	Air Force Speciality Code
ANG	Air National Guard
ANGB	Air National Guard Base
AOTS	Advanced On-the-job Training System
ASVAB	Armed Services Vocational Aptitude Battery
ATR	Airman Training Record
BDM	BDM Corporation
BSED	Ball Corporation, Systems Engineering Division
BO	Behavioral Objective
CAFSC	Career Air Force Speciality Code
CAI	Computer Assisted Instruction
CAMS	Core Automated Maintenance System
CAT	Computer Assisted Training
CBPO	Consolidated Base Personnel Office
CDC	Career Development Courses
CDTS	Computer Directed Training System
DCM	Deputy Commander for Maintenance
DOB	Date Of Birth
DOS	Date Of Separation
ECI	Extension Course Institute
Ext.	Extension
FAC	Functional Account Code
FIG	Fighter Interceptor Group

FMI	Functional Management Inspection
GPTR	Generic Position Task Requirements
HSD	Human Systems Division (of Air Force Systems Command)
HRL	Human Resources Laboratory
ID	Identification
ISD	Instructional Systems Development
ISS	Instructional Support System
IST	Instructional Support Team
ITR	Individual Training Requirements
MAJCOM	Major Command
MGMT	Management
MTL	Master Task List
OJT	On-the-Job Training
OMR	Optical Mark Reader
OPTR	Operational Position Task Requirements
OTGs	Oral Test Guides
OTR	Other Training Requirements
PAS	Personnel Accounting Symbol System
PCIII	Personnel Concept III
PECs	Performance Evaluation Checklists
PDS	Personnel Data System
PECs	Performance Evaluation Checklists
PQT	Position Qualification Training
PRP	Personnel Reliability Program
PUBs	Publications
QC	Quality Control
R&D	Research and Development
SHM	Short Haul Modem
SLT&E	System Level Test and Evaluation
SMEs	Subject Matter Experts
SOAs	Separate Operating Agencies/Activities
SPAS	Security Police Automated System
TAC	Tactical Air Command
TDY	Temporary Duty
TFG	Tactical Fighter Group
TIB	Test Item Bank
TRW	Tactical Reconnaissance Wing
TX	Texas
UMDs	Unit Manning Documents
USAFOMC	United States Air Force Occupational Measurement Center

9 APPLICABLE DOCUMENTS

Document:

Bergstrom AFB; Site Preparation Requirements and Equipment Installation Plan, prepared by Douglas Aircraft Company, division of McDonnell Douglas Corporation under contract F33615-84-C-0059 for the USAF; dated: 28 January 1988

Ellington ANGB; Site Preparation Requirements Plan, prepared by Douglas Aircraft Company, division of McDonnell Douglas Corporation under contract F33615-84-C-0059 for the USAF; dated: January 26, 1988

Facilities Requirements Plan for the Transition of the Advanced On-the-job Training System to Ellington Air National Guard Base, prepared by Ball Corporation, Systems Engineering Division/BDM Corporation under contract F33615-84-0070 by BDM Corporation for the USAF; dated: 16 October 1987

Master Test Plan; prepared by Douglas Aircraft Company, division of McDonnell Douglas Corporation under contract F33615-84-C-0059 for the USAF; dated: 21 August 1987, Revision 2.0

Interim Technical Report; prepared by Douglas Aircraft Company, division of McDonnell Douglas Corporation under contract F33615-84-C-0059 for the USAF; dated: December 30, 1986

Maintenance Plan; prepared by Douglas Aircraft Company, division of McDonnell Douglas Corporation; dated: October 28, 1986, Version 3.0

Computer Programming Standards Document; prepared by Douglas Aircraft Company, division of McDonnell Douglas Corporation under contract F33615-84-C-0059 for the USAF; dated: 15 September 1986

System Engineering Management Plan; prepared by Douglas Aircraft Company, division of McDonnell Douglas Corporation under contract F33615-84-C-0059 for the USAF; dated: September 30, 1986, Version 2.1

Human Engineering Plan; prepared by Douglas Aircraft Company, division of McDonnell Douglas Corporation under contract F33615-84-C-0059 for the USAF; dated: 20 January 1987

Reliability Program Plan; prepared by Douglas Aircraft, a division of McDonnell Douglas Corporation under contract F33615-84-C-0059 for the USAF; dated: September 3, 1986

Maintainability Program Plan; prepared by Douglas Aircraft, a division of McDonnell Douglas Corporation under contract F33615-84-C-0059 for the USAF

- Configuration Management Plan; prepared by Douglas Aircraft, a division of McDonnell Douglas Corporation under contract F33615-84-C-0059 for the USAF; dated: December 19, 1986, Version 1.01
- 70S647000; AOTS System Specification (A1); prepared by Douglas Aircraft Company, division of McDonnell Douglas Corporation under contract F33615-84-C-0059; dated: May 5, 1985
- 70S647100; Management Subsystem Prime Item Specification (B1); prepared by Douglas Aircraft Company, division of McDonnell Douglas Corporation under contract F33615-84-C-0059; dated: March 13, 1987
- 70S647300; Evaluation Subsystem Prime Item Specification (B1); prepared by Douglas Aircraft Company, division of McDonnell Douglas Corporation under contract F33615-84-C-0059; dated: November 7, 1986
- 70S647200; Training Development and Delivery Subsystem Prime Item Specification (B1); prepared by Douglas Aircraft Company, division of McDonnell Douglas Corporation under contract F33615-84-C-0059
- 70S647400; Computer Support Subsystem Prime Item Specification (B1); prepared by Douglas Aircraft Company, division of McDonnell Douglas Corporation under contract F33615-84-C-0059
- 70S647401; Critical Item Development Specification for the Hardware Component of the Advanced On-the-job Training System; prepared by Douglas Aircraft Company, division of McDonnell Douglas Corporation; dated: 1988, Version 2.0
- 70S647201; Training Development Component (B2) Specification; prepared by Douglas Aircraft, a division of McDonnell Douglas Corporation under contract F33615-84-C-0059 for the USAF
- 70S647202; Training Delivery Component (B2) Specification; prepared by Douglas Aircraft, a division of McDonnell Douglas Corporation under contract F33615-84-C-0059 for the USAF
- 70S647411; Management Subsystem CPCI (B5) Specification; prepared by Douglas Aircraft, a division of McDonnell Douglas Corporation under contract F33615-84-C-0059 for the USAF
- 70S647413; Evaluation Subsystem CPCI (B5) Specification; prepared by Douglas Aircraft, a division of McDonnell Douglas Corporation under contract F33615-84-C-0059 for the USAF
- 70S647414; System Support CPCI (B5) Specification; prepared by Douglas Aircraft, a division of McDonnell Douglas Corporation under contract F33615-84-C-0059 for the USAF
- 70S647412; Training Development and Delivery Subsystem B5 Specification; prepared by Douglas Aircraft, a division of McDonnell Douglas Corporation under contract F33615-84-C-0059 for the USAF
- 70S647411; Management CPCI (C-5) Specification; prepared by Douglas Aircraft, a division of McDonnell Douglas Corporation under contract F33615-84-C-0059 for the USAF

70S647413; Evaluation CPCI (C-5) Specification; prepared by Douglas Aircraft, a division of McDonnell Douglas Corporation under contract F33615-84-C-0059 for the USAF

70S647414; System Support CPCI (C-5) Specification; prepared by Douglas Aircraft, a division of McDonnell Douglas Corporation under contract F33615-84-C-0059 for the USAF

70S647412; Training Development and Delivery CPCI (C-5) Specification; prepared by Douglas Aircraft, a division of McDonnell Douglas Corporation under contract F33615-84-C-0059 for the USAF

Contract F33615-84-C-0059; United States Air Force and Douglas Aircraft Company, a division of McDonnell Douglas Corporation; dated: 1 August 1985

MIL-STD-490, 30 OCT 1968, Military Standard Specification Practices

MIL-STD-483, Notice 2, 21 Mar 1979, Configuration Management for System, Equipment, Munitions, and Computer Programs

MIL-STD-1815A, 22 Jan 1983, Ada Program Language

AFHRL-TR-75-83, "On-The-Job Training in the Air Force" by R.W. Stephenson and J. R. Burkett, dated: December 1975

PN 76-269, Air Force Inspector General Functional Management Inspection (FMI) report titled: "On-The-Job Training in the Air Force", dated: April 1977

AFHRL-TP-83-54, "Integrated Training System for Air Force On-The-Job Training: Specification Development", dated: March 1984

STRUCTURED SYSTEMS ANALYSIS: TOOLS and TECHNIQUES, Gane, C. and Sarson, T., McDonnell Douglas Corporation, 1982

HIPO- A Design Aid and Documentation Technique, IBM, 1975

AFR 50-23, Regulation, On-the-Job Training

10 APPENDIX A – ATR Screen Displays

This appendix has representative screen displays from the ATR. Various users will find information displayed, during SLT&E, taken from the AOTS data base. These screen representations will give readers of this document a feel of what the system will actually display.

Training Record Manager Personnel Data		
Personal Information		
1. Name:	3. TAFMSD:	SSAN:
2. DOB:	4. DOS:	7. Projected Grade:
5. Enlistment Category:	6. Grade:	
AFSC Information		
8. Primary AFSC:	9. Fourth AFSC:	
10. Secondary AFSC:	11. Control AFSC:	
12. Third AFSC:	13. Duty AFSC:	
Position Information		
14. Number:	15. Duty Status:	16. Record Status:
17. Title:	18. Phone Ext:	
19. Date Arrived Station:	20. Office Symbol:	
21. Date assigned to workcenter:	22. Duty Type:	
Organization Information		
23. Number :	24. Type:	25. Location ID:
26. Projected PAS:	27. PAS:	28. FAC:
29. Nomenclature:	30. Detachment #:	
31. Installation:	32. Printer ID:	

Training Record Manager - Personal, Position, and Organization Information

ATR Manager General Training History for
1. Training Status Code:
2. Date Entered/Completed/Withdrawn UGT:
3. Date Entered/Completed/Withdrawn Training:
4. Date Entered/Completed Position Qualification Training:
5. Date Initially Entered Re-Training:
6. High Education Level:
7. Secondary Education Level:
8. ASVAB Administrative Score:
9. ASVAB Mechanical Score:
10. ASVAB Electronics Score:
11. ASVAB General Score:
12. Reading Achievement Score 1:
13. Date Test 1:
14. Reading Achievement Score 2:
15. Date Tested 2:
16. Typing Test Score:
17. Date of Typing Test:

Training History Information

Training Record Manager
Professional Military Education for

1. ID: _____
Date Completed: _____
Installation: _____

Training Record Manager - Professional Military Education

Training Record Manager
Other Formal Training for

1. ID: _____ PDS Code: _____ Date Completed: _____
Title: _____
Installation: _____

Training Record Manager - Other Formal Training Information

Training Record Manager
ECI/CDC Training for

<u>Course Number</u>	<u>Completion Date</u>	<u>Course Number</u>	<u>Completion Date</u>
1.			

Training Record Manager - ECI/CDC Training

Training Record Manager
Ancillary History for

1. ID: _____ Date Completed: _____
Title: _____
Installation: _____

Training Record Manager - Ancillary History Information

**Training Record Manager
Additional Duty History for**

1. ID: _____ Date Completed: _____
Title: _____
Installation: _____

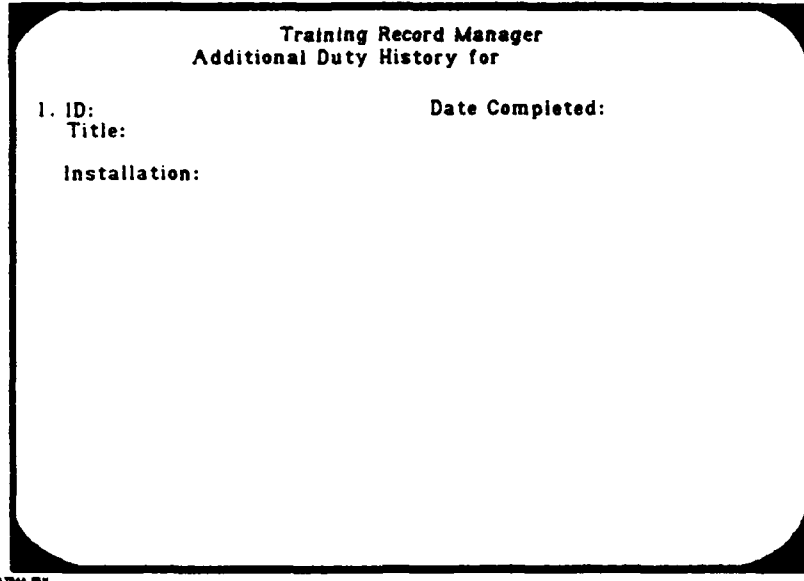
A screenshot of a software form titled "Training Record Manager Additional Duty History for". The form contains three input fields: "ID:", "Title:", and "Installation:", each followed by a blank line. To the right of the "ID:" field is a "Date Completed:" field with a blank line. The form is enclosed in a black border with rounded corners.

Training Record Manager - Additional Duty History Information

**Training Record Manager
Contingency History for**

1. ID: _____ Date Completed: _____
Title: _____
Installation: _____

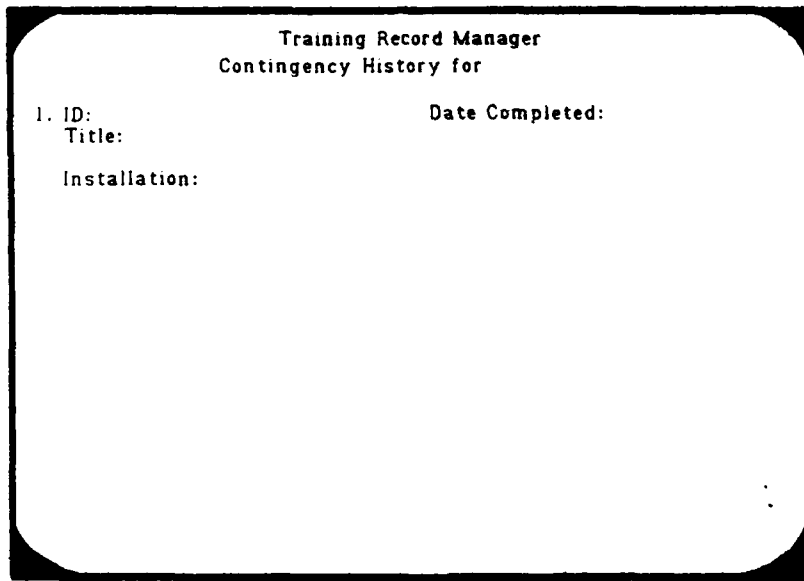
A screenshot of a software form titled "Training Record Manager Contingency History for". The form contains three input fields: "ID:", "Title:", and "Installation:", each followed by a blank line. To the right of the "ID:" field is a "Date Completed:" field with a blank line. The form is enclosed in a black border with rounded corners.

Training Record Manager - Contingency History Information

Training Record Manager
AOTS Task Training for

1. ID:	Version:	Date Certified:
--------	----------	-----------------

Trainer:
Evaluator:
Certifying Official:
Installation:

Training Record Manager - AOTS Task Training Information

11 APPENDIX B - The Prototype AOTS Configuration

The purpose of this appendix is to provide details on various aspects of the prototype Advanced On-the-job Training System's (AOTS) Computer Support Subsystem. The system's architecture will be discussed, the Bergstrom AFB and Ellington ANGB installations, how the hardware was selected along with selected specifications/requirements, and the software architecture. It is not the intent of this appendix to discuss AOTS from a training system aspect.

11.1 System Architecture

The prototype Advanced On-the-job Training System (AOTS) is based on a centralized computer architecture. The AOTS data base is the central location where all information is stored. Figure 11-1 provides a high level overview of the prototype architecture. The central computer, a Digital Equipment Corporation VAX 8650 computer, is located at AFHRL/TS at Brooks AFB. High speed digital communications link Bergstrom AFB and Ellington ANGB to the VAX computer.

Zenith Z-248 Personal Computers (PCs) are used for the AOTS terminals. Only limited local processing occurs at the PC. There will be located at various PC terminals a dot matrix printer (Alps P2000G) and an optical mark sense reader. The latter is a device for reading in test forms. AOTS offers the capability of administering tests off-line and the results are entered into the computer with a special mark sense form. These forms are in common use currently in the Air Force.

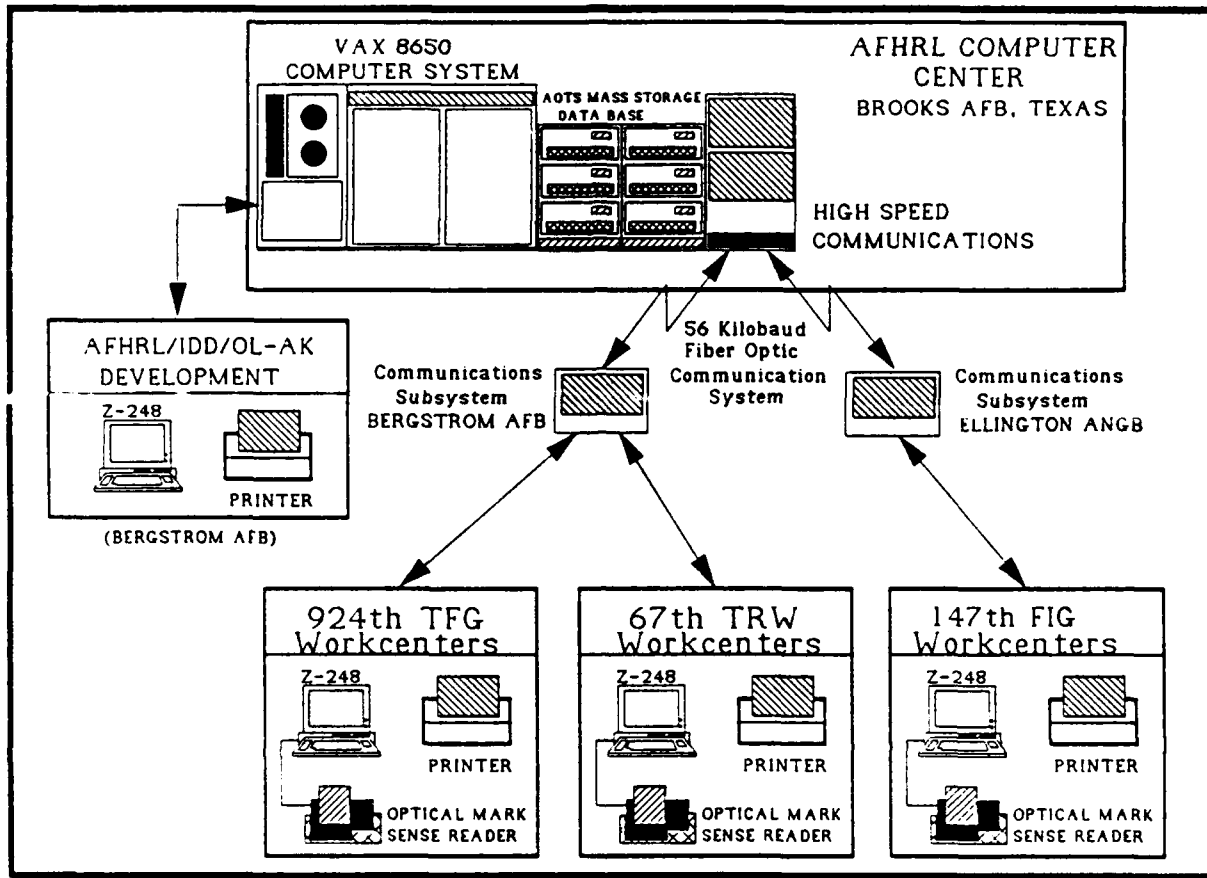

Figure 11-1 The Prototype AOTS Hardware Configuration

Table 11-1 provides an overview of each major type of equipment used and the total quantities of each in the prototype type AOTS. The VAX computer system was an existing Air Force asset used with the remainder of the equipment either purchased or leased specifically for AOTS.

Model/Part Number	QTY	Description	Manufacture
VAX 8650	1	Computer System (Located AFHRL/TS at Brooks AFB, TX)	Digital Equipment Corporation
56 Kilo baud Communications Lines	3	Two from Brooks AFB, TX to Bergstrom AFB, TX and one from Brooks AFB to Ellington ANGB, TX.	Clay Desta
56KB Multiplexers and Modems	4 Sets	One set located at Brooks AFB, two sets at Bergstrom AFB, and one set at Ellington ANGB.	Infotron
Zenith ZWX-248-52	85	Personnel Computer	Zenith
Zenith ZVM-1380	85	Color Monitor for Z-248	Zenith
Zenith/Alps P2000G	22	Dot Matrix Printer	Zenith/Alps
Model 5200	17	Optical Mark Reader	Scantron
LaserJet 500 Plus	5	Laser Printer and font cartridges	Hewlett Packard
LaserJet II	2	Laser Printer and font cartridges	Hewlett Packard
Ethernet Local Area Network	1	Ethernet Local Area Network (LAN)	3Com
Ada Compiler	2	Software, Ada compiler, with extended memory board, for PC	Alsys
Color Printer, Okidata 20	3	Color printer with parallel and serial interfaces	Okimate
Digitizer Tablet	2	Digitizer 20 X 20 inch	Summagraphics
Bit Pad	2	Digitizer Pad	Summagraphics

Table 11-1 AOTS Prototype Equipment Types and Quantities

11.2 Communications

The high speed communication subsystem used (Figure 11-1) is three leased 56 kilobaud lines from Clay Desta. The link between the central cities of San Antonio, Austin, and Houston is with fiber optics. The final link from Clay Desta's central offices to the bases uses conventional copper telephone lines with special signal repeaters.

11.3 Bergstrom AFB Installation

The AOTS communication configuration for Brooks AFB and Bergstrom AFB is provided in Figure 11-2. The topology used resembles a ring network. It is not a true ring type local area network but does have some key features that resemble a ring. Redundancy is provided to the users: should one of the two major lines fail, the load will be switched to the other. The system also has auto load level so that response level will be maintained at the highest possible level.

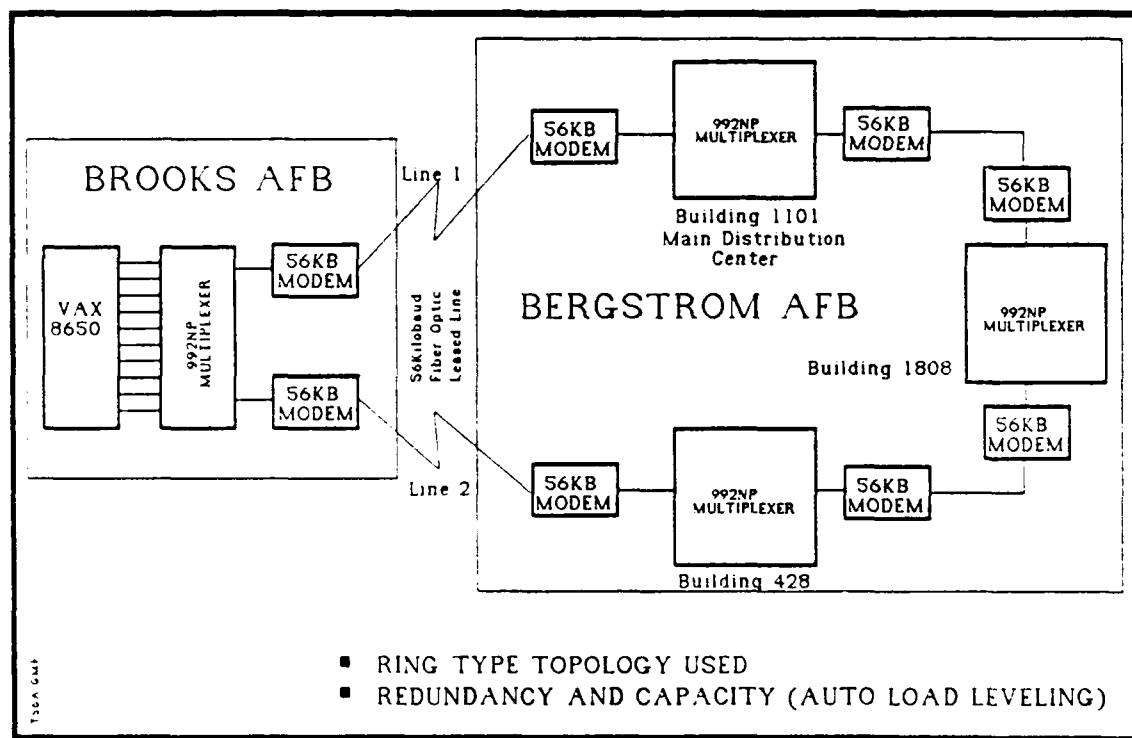

Figure 11-2 The Bergstrom/Brooks AFB Communication System

Table 11-2 provides a breakdown on all equipment that will be used on Bergstrom AFB. Figure 11-2 provides a detail communication diagram for Bergstrom AFB. Building 1101 is the Bergstrom Communication Squadron main building and the largest multiplexer will be located there. It is from this building, using existing Bergstrom AFB communication lines, that the various users will be connected to the central computer.

The high speed lines going to Buildings 1808 (specially built by AFHRL for this project) and Building 428 also have multiplexers. During the development phase of AOTS (Phase II), a single leg of the communication system diagram in Figure 11-3 was used connecting these buildings to the VAX computer at Brooks AFB. The multiplexers will remain in use throughout the contract. Building 1808 is used for the AFHRL/IST personnel who are developing the data base. Building 428 is the location for the Douglas Aircraft Company personnel who are developing the prototype AOTS.

Location at Bergstrom AFB	Z-248	OMR	Printer	Communication Lines
JET ENGINE MAINTENANCE BLDG 1612	2	1	1	5
BLDG 4529	1	0	0	2
BLDG 4589 (RES.)	2	1	1	6
A/C MAINTENANCE BLDG 1609	1	1	1	4
BLDG 4529	2	1	1	6
BLDG 4515 (RES.)	2	1	1	6
PERSONNEL BLDG 2202	3	1	1	8
BLDG 208	1	0	0	2
BLDG 4555 (RES.)	1	1	1	4
BASE OJT MONITOR BLDG 2202	1	0	1	3
BLDG 2210	1	1	1	4
SECURITY POLICE BLDG 207	2	1	2	7
BLDG .08	2	0	1	5
BLDG 4204 (RES.)	2	1	1	6
CHIEFS OF MAINTENANCE TRAINING STAFF BLDG .501	4	1	2	9
BLDG 4592 (RES.)	1	1	1	4
AFHRL/OL-AK BLDG T-1	1	1	1	6
BLDG 1808	25	1	4	2
BLDG 428	10	0	1	2
TOTALS:	64	14	22	91

Table 11-2 The Bergstrom Equipment List by Organization and Building

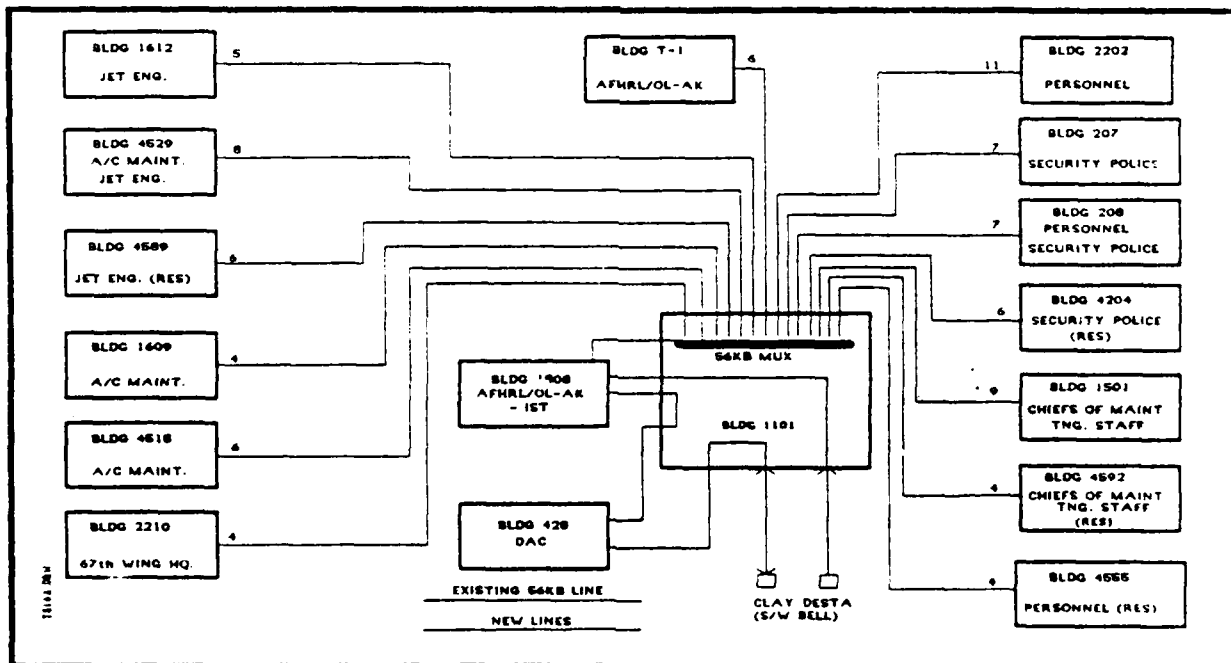

Figure 11-3 Bergstrom Communication Layout

11.4 Ellington ANGB Installation

The Air National Guard (ANG) was added to the prototype AOTS after the start of the current AOTS efforts. Figure 11-4 illustrates the ANG equipment configuration. The ANG will also use the VAX computer at Brooks AFB (AFHRL/TS) same as the active and reserves at Bergstrom AFB. The major difference is in the amount of equipment. The configuration and quantity of equipment is based on the routine ANG UTA events. All of the equipment used at Ellington ANGB is of the same type as used at Bergstrom AFB. No new hardware or software has been developed for the ANG.

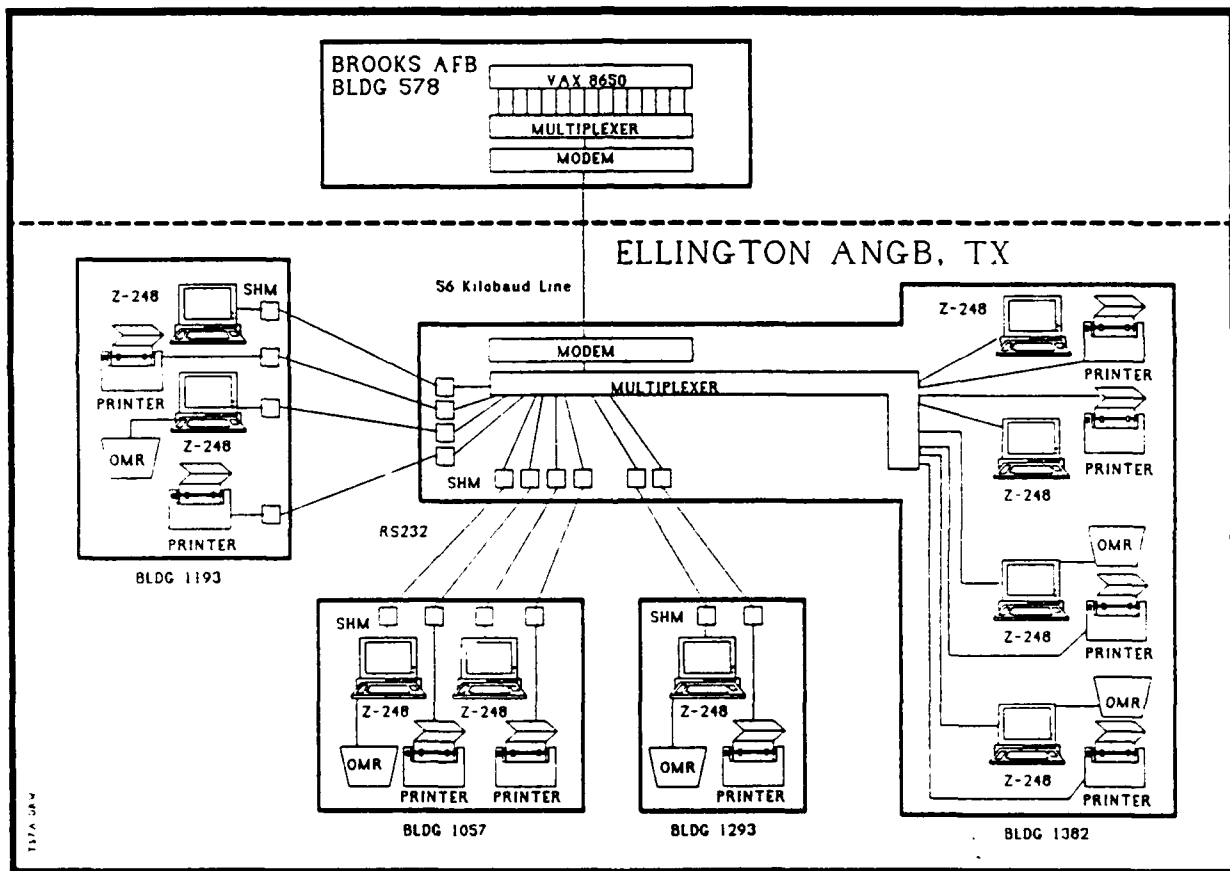

Figure 11-4 Ellington ANGB Equipment and Communication Layout

Table 11-3 shows the equipment, by building location, that will be used by the Air National Guard at Ellington ANGB. Table 11-4 is the total equipment procured for the ANG.

Location at Ellington ANGB	Z-248	OMR	Printer	Communication Lines
Building 1382	4	2	4	12
Building 1293	1	1	1	3
Building 1057	2	1	2	5
Building 1193	2	1	2	5
TOTAL:	9	5	9	25

Table 11-3 The Ellington ANGB Equipment Distribution by Building

PART NUMBER	QTY (ea.)	DESCRIPTION	MANUFACTURE	LOCATION	REMARKS
992/SU SM632/2-790	1 1	Control Unit Expansion Chassis	Infotron Infotron	Ellington ANGB Brooks AFB	Allows existing 992/SU at Brooks to be used for ANG communication line.
CL790/LM790V	2	Link Modules	Infotron	Brooks AFB	Allows Bergstrom to control ANG communications.
CA790/4M4	7	Quad Board 4 RS232 ports	Infotron	Ellington ANGB	1 at Ellington is a spare
LD8/5 LD8/1	10 10	Short Haul Modem Short Haul Modem	Infotron Infotron	Ellington ANGB Ellington ANGB	
CL790/LM600	1	Link board for SM632	Infotron	Brooks AFB	Links SM632 and 992/SU
CA600/4-790	8	Quad Board for SM632	Infotron	Brooks AFB	4 RS232 Ports
DDS-56	3	56KB Modem	UDS	2 at Ellington 1 at Brooks	1 at Ellington ANG is a spare
SWTC-PVC4C24 PWC-02P24	1000 Ft 2000 Ft	4 Wire Cable Cable Twisted Pair	Graybar Graybar	Ellington ANGB Ellington ANGB	
56KB digital data line	13 (Months)	56 Kilobaud Leased Line	Clay Desta	Ellington ANG to Brooks AFB	A leased line for 12 months
Houston Loop	13 (Months)	Local Houston Loop	Clay Desta	Ellington ANGB	
San Antonio Loop	13	Local San Antonio Loop	Clay Desta	Brooks AFB	
5200	5	Optical Mark Sense Reader	Scantron	Ellington ANGB	
87F2866	10	Power Strip	Newark	Ellington ANGB	
5200 6C/C	5 23	Cable Cable, RS232	Innovative Innovative	Ellington ANGB Brooks AFB	Scantron to PC VAX to MUX

Table 11-4 - Air National Guard Equipment List for SLT&E

11.5 Hardware Selection Process

During the preliminary design phase of the AOTS (Phase I), trade studies were conducted to determine what equipment would be needed to meet the AOTS requirements. Hardware and some software trade studies were conducted. These trade studies were broken down into various key fields.

11.5.1 Trade Studies

The two principal hardware trade studies focused on the central computer and the terminals. Smaller trade studies also were conducted for the printers, digitizer tablets, and optical mark sense readers.

The trade study centered on three vendors. These were Digital Equipment Corporation (DEC), Gould Corporation, Computer Systems Division, and Data General Corporation (DG). Three valid computer systems were determined could meet the AOTS requirements. These were, by rating starting with the highest rated to lowest acceptable, the Gould 9000 system, DEC VAX 8650, and DG MV2000. AFHRL could provide a DEC VAX 8600 within existing inventory which could be upgraded to a 8650 at minimum expenditure of funds. Thus, the DEC VAX 8650 was selected. The key characteristics of the central computer are provided in Table 11-5.

COMPONENT	REQUIREMENTS
Computer:	Have a Validated Ada compiler 32 Bit Machine Virtual Memory addressing 5 MIPS (Phase II) Performance 10 MIPS (Phase III) Performance Separate Floating Point Accelerator Cache Memory (minimum of 8 kilobytes) Vector Priority Interrupt Structure Real Time Clock and Interval Timer I/O bandwidth of 20 megabytes/second Virtual Memory Disk Based Operating System
Memory:	64 Megabytes of main memory
Disk Storage:	1.3 Gigabytes of disk storage using multiple spindles and controllers
Magnetic Tape:	FIPS PUB 25 compatible
Line Printer:	445 Lines Per Minute with a 96 character set
Communications:	64 RS232C ports (minimum of 48 required Phase II) 124 RS232C ports (Phase III)
Physical Considerations:	Operate using conventional power 115 - 220 VAC, up to three phases, 60 Hz Operate on conventional air conditioning while maintaining 72 degrees F, +/- 8 degrees F Meet FCC emissions standards (Part 15 Subpart J, Level A)
Reliability/Maintainability:	MTBF of 600 hours minimum (goal) MTRR of 1.5 hours maximum (goal)

Table 11-5 AOTS Central Computer System Requirements

The terminal selection first had to resolve some fundamental questions. These were:

- a) Was color a requirement?

- b) Was graphics a requirement?
- c) How smart or intelligent should the terminal be?

As the result of analysis of the AOTS prototype requirements, the terminals were determined to require color, medium resolution graphics, and should be capable of future growth. Table 11-6 provides an overview of the higher priority specifications. The key parameters are:

- a) 16 Colors for both text and graphics
- b) 600 X 350 graphic resolution
- c) Growth to an intelligent terminal
- d) Ergonomically designed for ease of use by any type of user
- e) Highly reliable

Extensive trade studies were conducted into various vendors of personal computers, color monitors, graphic capabilities, ergonomics, reliability, and cost. It was also determined that the prototype AOTS should stay on the leading edge of technology without taking undo risks. This led to the decision to only study PCs that used the 80286 microprocessor. This eliminated all 8088/8086/80186 designs as approaching obsolescence. The 80386 machines were only just being prototyped and were considered, for the prototype, as too risky. It was further decided that the 68000 microprocessor based PCs were either too costly or too limited in capability (e.g. no color capability). Once the 80286 was the type of microprocessor, it was determined that the prototype AOTS should also stay as close to standards as possible. There strong indications that the Air Force was leaning toward the IBM PC AT type of PC for meeting its existing requirements. Further, the 80287 numeric coprocessor should also be added to all prototype AOTS terminals.

A trade study was conducted on IBM AT type PCs. The study was reduced to IBM, Zenith, Compaq, Sperry, Hewlett Packard, ITT, and AT&T. The study determined that all met or exceeded requirements and that cost or other factors should be used to make the final determination. At the time the trade studies were being concluded, the Air Force issued the procurement for the Zenith Z-248 PCs. Thus, AOTS selected the Z-248 for the prototype terminal.

The trade studies for the color monitor and the graphics capability also closely mirrored the capabilities offered in the IBM PC AT. These included the existing monochrome text and graphics capability, the Color Graphics Adapter (CGA) standard, Extended Graphics Adapter (EGA) standard, and Professional Graphics Adapter (PGA) standard. The CGA was inadequate for meeting the resolution requirements and the PGA was considered too expensive. The EGA standard meets AOTS resolution and color requirements and was also part of the standard buy of Zenith Z-248 personal computers.

The result of the trade studies was a set of requirements. These requirements are provided in Tables 9-6 and 9-7 which describe the AOTS terminal and peripherals requirements.

COMPONENT	REQUIREMENTS
Computer:	80286 microprocessor at 8 MHz MS-DOS 3.1 or higher operating system IBM PC AT compatible QWERTY detached keyboard AT style One Parallel Printer Port (Centronics compatible) Two RS232C Serial Ports capable of 9600 baud rates IBM Standard Graphics Board (EGA) 480 X 360 resolution for the graphics Non-interlaced output RS-170 compatible Minimum of 16 color palette 96 character set with true descenders 9 x 11 character cell or 8 x 14 character cell minimum Capable of supporting a light pen Capable of supporting a mouse Capable of supporting interactive video controllers and graphics/text overlay capability in color Meet FCC Part 15, Subpart J, Class A emissions (minimum)
Memory:	Minimum of 512 kilobytes of memory Expandable to 4 megabytes
Disk Storage:	360 Kilobaud IBM standard floppy disk 20 Megabyte hard (Winchester) disk Access time maximum of 90 milliseconds for the hard disk
Reliability/ Maintainability:	MTBF 2000 hours minimum MTTR 0.5 hour maximum
Monitor:	12 to 14 inch (diagonal) Color EGA Compatible (non-interlaced) Minimum flicker (medium to long persistence phosphor) Medium resolution (640 x 480) 9300 degree Kelvin color temperature Low glare screen Meet FCC Part 15, Subpart J, Class A emissions (minimum) MTBF of 15,000 hours and MTTR of 0.5 hour
Monitor (Video):	NTSC compatible 6500 degree Kelvin color temperature All other specs of the monitor above

Table 11-6 The AOTS Terminal Specifications

The Computer Assisted Training Subsystem has a requirement for Interactive Video Development (IVD). The Sony LDP2000/2 or /3 were considered as meeting the AOTS IVD needs. This is the same machine that is implemented into the ISS software. The Electrohome color monitor with touch screen will also be used. Touch screen will not be used in the prototype AOTS. The color graphics adapter used is manufactured by Matrox. This is the same adapter as used by the U.S. Army's EIDS.

COMPONENT	REQUIREMENTS
Optical Mark Sense Reader:	Optical technology for reading forms 12 inches per second scanning rate minimum 8.5 x 11 inch paper size Bubble matrix 80 x 25 x 2 minimum sensors RS232C interface (two or pass through) Meet FCC Part 15, subpart J, Class A (minimum)
Printer, Color:	Minimum of 4 colors Support graphics (screen dumps from EGA) Bidirectional printing Multi-densities Dot matrix, 100 dots per inch minimum Printing speed, high - 100 characters per second (CPS), low - 35 CPS Regular bond paper (20#) compatible Parallel (Centronics compatible) and RS232 interfaces MTBF 2000 hours, MTTR 0.5 Meet FCC Part 15, subpart J, Class A (minimum)
Printer: Monochrome - Laser	Dot matrix using a laser Text and graphics capable 300 dots to the inch minimum 8 pages per minimum speed Parallel (Centronics compatible) and RS232 interfaces MTBF 2000 hours, MTTR 0.5 Hold a minimum of 500 sheets of 8.5 x 11 bond (#20) paper (plain copier type) Support up to five different fonts at one time Noise level not to exceed 55 db Meet FCC Part 15, subpart J, Class A (minimum)
Printer: Monochrome - impact dot matrix	Dot matrix using pin head impact technology Text and graphics capable Parallel (Centronics compatible) and RS232 interfaces MTBF 2000 hours, MTTR 0.5 Have tractor feed capability for conventional computer paper Not exceed 70 db noise level Meet FCC Part 15, subpart J, Class A (minimum)
Digitizer Tablet:	11 x 11 inch digitizing area (type 1) 20 x 20 inch digitizing area (type 2) RS232 interface Resolution of .005 inch Accuracy of .005 inch Cursor puck with a minimum of 2 control buttons Meet FCC Part 15, subpart J, Class A (minimum)
General Specifications for all items	All items must be safe to operate and handle Easy to transport Meet office environment Operating temperature range: 65 to 75 degrees Fahrenheit for the computer system 55 to 90 degrees Fahrenheit for all other items 20 to 80 percent relative humidity (non condensing)

Table 11-7 AOTS Peripheral Specifications

The Zenith contract also eliminated the need for too extensive trade studies for printer selection (see Table 11-7 for key specification requirements for printers). The Alps P2000G dot matrix printer was determined to meet most of the printer needs for AOTS. For development purposes (both software and data base), high speed printing was needed. Requirements for development of documentation along with the high speed printing need led to the selection of laser printers. The Hewlett Packard Laserjet + 500 printers and Laserjet II have been used for these latter requirements. A limited number of Okidata Okimate 20 color printers were procured for getting color screen dumps from the Zenith Z-248s.

Trade studies were also conducted for selecting optical mark sense readers (OMR) and digitizer tablets (see Table 11-7 for key specification requirements). The OMR selection is limited by the small number of possible vendors. The process selected the Scantron Corporation, model 5200 OMR. Two types of digitizer tablets were selected. One was a 20 inch by 20 inch tablet for large drawings being digitized and the other was an 11 by 11 inch tablet that was also part of the standard Zenith contract.

11.5.2 Selection Process

Criteria for selection varied somewhat with each type of equipment. Key factors in the process were:

- a) Meeting AOTS technical requirements
- b) Cost
- c) Reliability, maintainability, support (logistics)

One of the major influencing factors was the Air Force standard contract with Zenith and existing Air Force assets (e.g. the DEC VAX 8600 computer). Elsewhere, the lowest cost approach meeting technical requirements guided procurements. Douglas Aircraft Company procured the communications (leased the lines from Clay Desta and purchased the modems and multiplexers from Infotron), the optical mark sense readers (Scantron), laser printers (Hewlett Packard), color printers (Okidata), and the large digitizer tablets (Summagraphics). All procured items will become Air Force inventory at the conclusion of the contract with Douglas Aircraft Company.

11.5.3 Phased Procurements

Hardware was procured in two basic increments. The first increment of hardware procured was to meet the development phase needs (Phase II). The second procurement was to meet the remaining needs for SLT&E (Phase III).

11.5.4 Reliability, Availability, and Maintainability

A tailored reliability program in accordance with MIL-STD-785 will evaluate system reliability, identify problems, and recommend solutions. At this time all data are stated as goals, as opposed to hard requirements, due to the developmental nature of the prototype AOTS. The results from the prototype will be used in specifying the production version that will be deployed throughout the Air Force.

The data will be judged against a minimum reliability of 0.8 for an 8 hour workcenter shift, 7 days per week, 52 weeks (a year) at a 90% confidence level. The following techniques will be used to achieve required levels of reliability.

- a) Use of various diagnostic routines
- b) Use of automatic error checking (built into hardware where applicable)
- c) Modular design (board level repair/replace)
- d) Component failure messages to operators (via reports, logs, direct displayed messages, etc.)

e) Identification of impending failures (i.e., graceful degradation)

Mission reliability prediction will be performed in accordance with MIL-STD-785B, paragraph 50.2.2.3.

11.5.4.1 Reliability Data

The overall design of the AOTS ensures system reliability. System reliability, aside from hardware and software concerns, will be tested at the user interface level during SLT&E. System reliability issues center around the concern users have for the consistency and accuracy of output after input has been processed. The users are also concerned as to how easily system corrections can be made if processing problems are discovered. Users of AOTS will review trainee and system status data to determine if the system, as designed, is working consistently and accurately (i.e., reliably). For example, if trainees are failing Quality Control evaluations at unacceptable rates, then it is apparent that AOTS is not functioning properly (i.e. it is not consistent: trainees are being certified but cannot perform their tasks) as a system. This information triggers the problem-solving process. Maintainability allows the user to trace effects to causes for this phenomenon. Table 11-8 provides the prototype AOTS goals for reliability.

Parameter	Goal
MTBF	250 Hours
MTBDE	400 Hours
Mission Reliability	99.5%
MCT	0.5 Hours
M max	0.5 Hours
Mptmax	32 Hours
Ai	99.5%
Aa	99.4%
Ao	99.8%
Service Life	10 Years
Operating Life	
Operating	25,000 Hours
On/Off Cycles	5,000 Cycles
Time Base (for calculations)	24 Hours

Table 11-8 Reliability Goals for the Prototype AOTS

11.5.4.2 Maintainability Data

Table 11-9 lists the goals for the maintainability of the AOTS hardware equipment.

Parameter	Goal
MTRR on the System	1.5 Labor hours
90% upper limit to repair	0.5 Labor hours
Mean-Time-To-Restore the system	0.5 Labor hours
Mean-Time-To-Restore the system - 90% upper limit to restore	1.0 Labor hours
Mean-Time-To-Remove and Replace	0.4 Labor hours
Mean-Time-To-Remove and Replace - 90% upper limit to Remove and Replace	1.25 Labor hours
Direct maintenance manhours per equipment operating hour	0.05 Hours
Response time to site of failure	4.0 Hours
Principal Period of Maintenance	16 Hours/day 7 days per week
Off line maintenance average MTRR	6.0 Labor hours
90% upper limit to repair	6.0 Labor hours
Mean preventive maintenance time	3 Hours
Mean Maintenance Time	3.4 Hours
Logistics Delay Time	4 hours (90%tile)
Maximum corrective maintenance time	8 Hours
Administrative delay time	2 Hours
Maintenance downtime	7.4 Hours
Maintenance manhours/month	6 Hours/Month
Frequency of Preventive Maintenance	1 time per month per workcenter

Table 11-9 Maintainability Data on the Prototype AOTS

The following factors have been used in the prototype AOTS using MIL-STD-470, MIL-STD-472, MIL-STD-421, and MIL-STD-1472 as guidelines:

- a) Use of built-in tests for rapid detection, isolation and correction of failures.
- b) Use of functional reverification to ensure proper operation.
- c) Use of standard tools and equipment to maximize interchangeability.
- d) Exchange of failed items.
- e) Use of modular design to enhance diagnostic capabilities.

AOTS has been designed and developed to ensure system maintainability. System maintainability, with the exception of software and hardware, will be tested at the user interface during the development and implementation of the prototype AOTS. A key aspect of maintainability is traceability. For hardware and software, documentation allows one to trace from effects back to causes. Similarly, AOTS products will be associated with one another by referential, or linking, identifiers. For example, task information will be linked to behavioral objectives, behavioral objectives to the test items, test items to evaluation instruments, etc. These connections provide a context for any one element and can help those responsible for system maintainability to adapt the system to changing conditions or to isolate deficiencies that result in unreliable outputs. As system deficiencies are detected through the use of system reports, problem areas can be

identified and solutions recommended. These solutions will be tested, new data collected, and system reports generated. This cycle of monitor for reliable outputs (i.e., review reports), document changes, and monitor again is the application of maintainability, or maintenance. Following the installation of the prototype AOTS, systems reports will provide insight into how maintainable the AOTS really is.

11.5.4.3 Availability Data

The prototype availability information is derived from the reliability and maintainability data. This data is taken from actual maintenance actions on AOTS equipment. The goals for the availability of AOTS hardware are provided in Table 11-10.

Parameter	Goal
System wide availability	96.5%
Computer System Component availability	98%
Terminal Component availability	98%
Printer Component availability	98%
Digitizer Pad Component availability	98%
Optical Mark Reader availability	96%
Remote Communications	95%

Table 11-10 The Prototype AOTS Availability Goals

11.5.4.4 Software Maintainability

Both weekly and daily backups of the AOTS software will be performed by the AFHRL Technical Support (TS) personnel. AFHRL-TS will also implement a disaster plan (i.e. have backup copies stored either in a secure area or at a different building from where the computer system is located).

Software maintenance also includes:

- a) Updates and new releases of system software (including support software packages - e.g. Ada compiler)
- b) Restoration of all data should a failure in the disk subsystem occur or a system "crash" result in loss of all data on a disk subsystem.

11.5.4.5 Performance Goals

Various performance (responsiveness) goals have been set for the prototype AOTS system. With the system operating under normal conditions, the average response performance goals for a user's terminal would be 2.5 seconds.

11.6 Software Architecture

11.6.1 Software Development

The prototype AOTS is using the MIL-STD-1815A Ada computer programming language. AOTS represents a major Air Force program using Ada with over 400,000 lines of source code. Approximately half of this software was newly developed for the prototype AOTS. The approximate other half came from the AFHRL Instructional Support System (ISS) project. ISS is also an AFHRL major Ada software project. In addition to Ada language, an Ada Design Language (ADL) is also being used.

The prototype AOTS software is broken down into Computer Program Configuration Items (CPCIs). The AOTS system consists of the following CPCIs:

- a) Management (Subsystem) CPCI
- b) Evaluation (Subsystem) CPCI
- c) Training Development and Delivery (Subsystem) CPCI (which is ISS software intact) **NOTE:** This is referred to as the Computer Assisted Training Subsystem within the body of the Operational Guide.
- d) System Support CPCI (part comes from ISS and the rest is newly developed software for the prototype AOTS)

11.6.2 Software Architecture

The prototype AOTS software architecture is based on a central computer system architecture. Figure 11-5 provides a "layered" diagram approach to how the AOTS software is engineered. The central core of the system is the DEC VAX 8600's computer operating system, VMS. The VAX 8600 VMS operating system is a virtual memory multiuser and multitasking operating system. Immediately outside the operating system is the software that interfaces other AOTS software with the operating system itself. This software, the system support layer, interconnects with the subsystems software through an intermediate layer. Figure 11-6 provides a vertical approach to diagramming the relationships. The outside layer is referred to as the application layer. This is where most of the "editors" are located as well as other user interfaces.

The Zenith Z-248 Personal Computer (PC) also is programmed in Ada. The Alsys Corporation's validated compiler was utilized. The operating system utilized on the prototype AOTS for the Z-248 is Microsoft's MS-DOS version 3.1. The Z-248 software developed for AOTS provides a "terminal emulation" capability. The terminal emulator takes data received from the VAX and interprets and displays it on the Zenith Z-248 hardware. A user can input data through the keyboard back to the VAX computer.

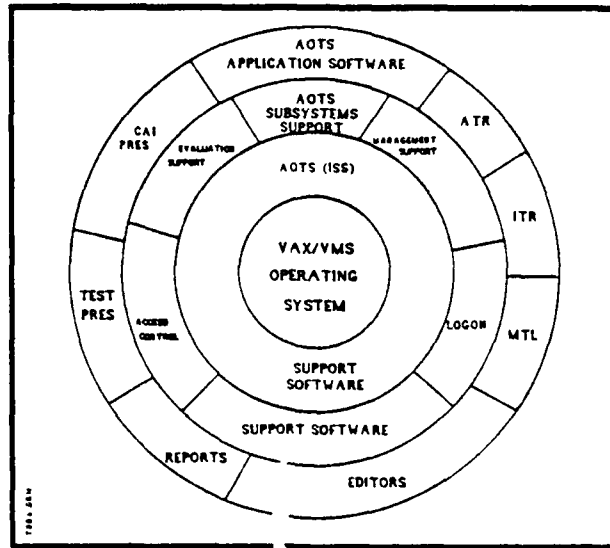

Figure 11-5 The AOTS Software Architecture

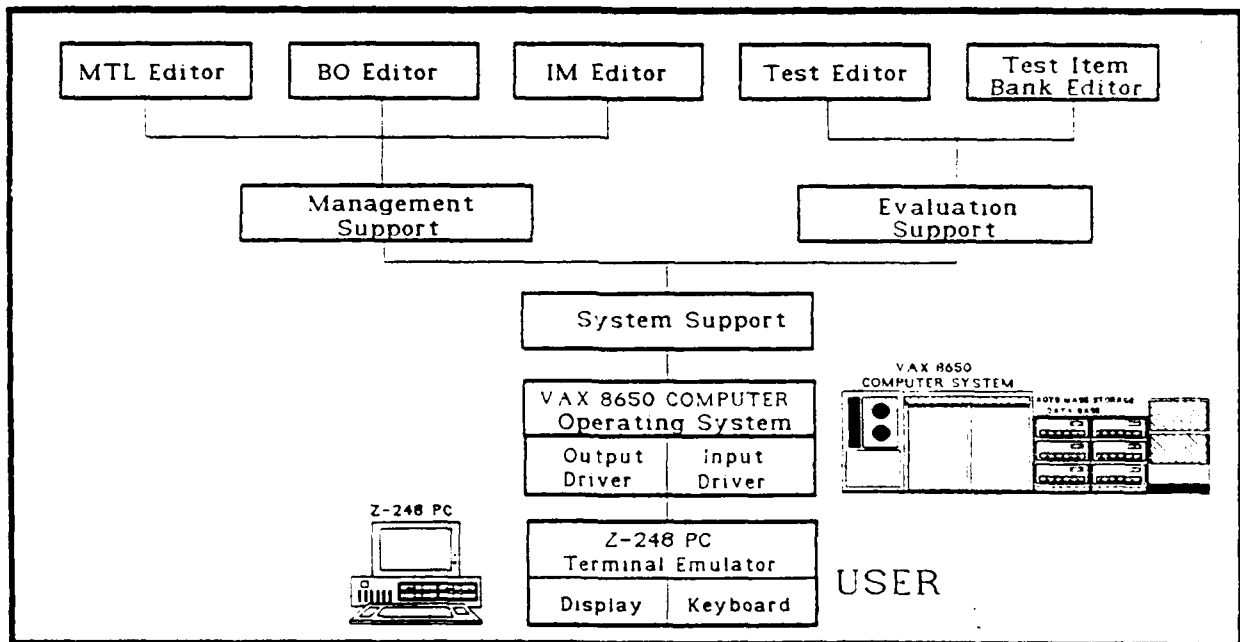

Figure 11-6 A Sample Vertical Interface Diagram

The Terminal Editor is used to denote a software package that allows a user to enter or alter data.

Various examples of the editors have been given in the main body of the Operational Guide document.

11.6.3 Standards Used

The prototype AOTS is using the MIL-STD-1815A Ada specifications. In addition, AOTS is using programming standards developed specifically for this program. These AOTS programming standards expand upon the MIL-STD by adding the Ada Design Language (ADL), AOTS standards package header documentation, and AOTS standard procedure/function header documentation.

AOTS is also using various limits that help in defining the AOTS software. A major example of these are the limits placed on a Ada package and module. An Ada package is limited (with exceptions) to being 1 to 2 thousand lines of code. An AOTS procedure/function is limited (with some exceptions) to 100 lines of code.

11.6.4 Computer Program Structure

The prototype AOTS computer programs consist of four Computer Program Configuration Items (CPCIs), and various Ada packages and Ada procedures/functions.

A Computer Program Configuration Item (CPCI) is the actual computer program end item in the form of computer instructions stored on machine-readable media. A CPCI will consist of one or more Ada packages.

An Ada procedure/function performs a complete logical process by execution of a set of instructions which have clearly defined inputs, processing logic, and outputs. A procedure/function is the smallest set of executable statements able to be compiled. Each module will conform to the following conventions:

- a) A procedure/function consists of a set of instructions in a form consistent with the Ada language, VAX/VMS operating system, and the VAX 8650 computer system.
- b) A procedure/function, with some exceptions, does not exceed 100 lines of executable source code. This limitation excludes comments and data definitions.
- c) A procedure/function has only one entry statement and one exit statement.

11.6.5 Top Down Design (TDD)

The overall approach to designing the AOTS software has been to use Top Down Design (TDD) methodology. The processing activities of the system are identified and organized beginning with higher levels of organization, (i.e., top levels). These higher levels are then expanded and broken out to include a more detailed definition of the processing activities by identification of subordinate levels. The lowest level of processing corresponds to the procedure/function.

11.6.6 Top Down Implementation (TDI)

The AOTS software has been implemented in a top down manner. Conceptually, top down implementation proceeds from a single starting point while conventional implementations proceed from as many starting points as programs in the design. The single starting point does not imply that the implementation has proceeded down the

hierarchy in parallel. For example, user or other external interfaces might be implemented before some of the other portions to permit early usage of the software subsystem capabilities, partial software system evaluation, and training.

11.6.7 Structured Coding and Operating System Requirements

Only well defined control constructs have been used in developing the AOTS software. These constructs use logically equivalent Ada language simulations. Some examples of these constructs are: IF-THEN-ELSE, DO, and CASE.

The operating systems used (on the DEC VAX 8600, VAX/VMS; and on the Zenith PC, MS-DOS) are existing off-the-shelf software packages. Changes/augmentations will be permitted to be embedded within vendor supplied operating system (OS) software. No AOTS changes/augmentations will affect the vendor supplied software, thus the maintenance of this software will be provided by the vendor for the life cycle of the system.

The program coding conventions that have been used include:

- a) Each line of source code contains no more than one statement.
- b) Source code is clearly and conspicuously annotated to explain all inputs, outputs, branches, and other items not implicit in the code itself.
- c) Names of operator commands, data entries, program components, variables, procedures, and other software components are consistent with those used elsewhere in the systems design.
- d) Code has been written such that no code is modified during execution.

11.6.8 Unit Development Folders

As part of the development effort, Unit Development Folders (UDFs) were maintained for each Ada package. The UDFs contain the design, source code listings, test procedures, test results, and history on each package. The UDFs are used for configuration control on each Ada package.

11.6.9 Utility Software Services

The support utility software provided includes such capabilities as:

- a) Validated Ada compilation capabilities
- b) Assembly which produces relocatable object code
- c) Linking type loader
- d) Generation, maintenance, and initialization of storage media for programs and data
- e) Diagnostics to support fault isolation

- f) Editing and debugging tools
- g) Source code configuration control tools
- h) Error handling (error detection and reporting) and logging of computer internal problems

• **11.6.10 Usage of ISS**

• Approximately half of the AOTS software comes from the ISS program. All of the Computer Assisted Instruction (CAI) and some of the system support software is taken from ISS intact.

11.7 Glossary Of Terms And Acronyms - APPENDIX B

ACRONYM	DEFINITION
ADL	Ada Design Language
AF	Air Force
AFB	Air Force Base
AFHRL	Air Force Human Resources Laboratory
AFHRL/IST	Air Force Human Resources Laboratory/Instructional Support Team
AFHRL/OL-AK	Air Force Human Resources Laboratory/Operating Location - AK (Bergstrom AFB, Texas)
AFHRL/TS	Air Force Human Resources Laboratory/Technical Services Division
AFR	Air Force Regulation
Aa	Availability, achieved
Ai	Availability, inherent
Ao	Availability, operational
ANG	Air National Guard
ANGB	Air National Guard Base
AOTS	Advanced On-the-job Training System
ATR	Airman Training Record
BLDG	Building
BO	Behavioral Objective
CAI	Computer Assisted Instruction
CGA	Color Graphics Adapter - a standard of resolution on IBM PCs
CPC	Computer Program Component
CPCI	Computer Program Configuration Item
CPS	Characters Per Second (when used with printers)
DAC	Douglas Aircraft Company
db	Decibels
DEC	Digital Equipment Corporation
DG	Data General Corporation
EA	Each
e.g.	example
EGA	Extended Graphics Adapter - a standard of resolution on IBM PCs
EIDS	Electronic Instructional Development System
F	Fahrenheit
FCC	Federal Communications Commission

Ft	Feet
FIG	Figure
IBM	International Business Machines Corporation
i.e.	that is
IM	Inventory Manager
I/O	Input/Output
ISS	Instructional Support System
ITR	Individual Training Requirements
IVD	Interactive Video Development
KB	Kilobaud
LAN	Local Area Network
M max	Maintenance maximum
MCT	Maintenance, complete time
MB	Megabytes
MHz	MegaHertz
MIL-STD	Military Standard
MIPS	Millions of Instructions Per Second
Mptmax	Maintenance preventive time maximum
MTBF	Mean Time Between Failures
MTL	Master Task List
MTTR	Mean Time To Repair
MUX	Multiplexer
NTSC	National Television Standard for Color transmission
OJT	On-the-Job Training
OMR	Optical Mark Reader or Optical Mark Sense Reader
OS	Operating System
PC	Personal Computer
PCs	Personal Computers
PGA	Professional Graphics Adapter - a standard of resolution on IBM PCs
PRES	Presentation
QA	Quality Assurance
QTY	Quantity
RES.	Reserves
SHM	Short Haul Modem
SLT&E	System Level Test and Evaluation
SU	System Unit
TDD	Top Down Design
TDI	Top Down Implementation
TFG	Tactical Fighter Group
TX	Texas
UDFs	Unit Development Folders

UDS	Universal Data Systems
U.S.	United States
UTA	Unit Training Activity
VAC	Volts, Alternating Current
VAX	Virtual Address Extension - A product designation for a line of computer manufactured by Digital Equipment Corporation
VAX/VMS	Virtual Address Extension/Virtual Memory System - the operating system designation used on a line of computer manufactured by Digital Equipment Corporation
%tile	percentile