

DTIC FILE COPY

AD



EVALUATE AND CHARACTERIZE MECHANISMS CONTROLLING TRANSPORT, FATE, AND EFFECTS OF ARMY SMOKES IN THE AEROSOL WIND TUNNEL

Subtitle: Transport, Transformations, Fate, and Terrestrial Ecological Effects of Mixed Obscurant Smokes

AD-A221 799

Final Report

Dominic A. Cataldo
Michael W. Ligothe
Harvey Bolton, Jr.
Robert J. Fellows

Peter Van Voris
Bruce D. McVeety
Shu-Mei W. Li
Kristin M. McFadden

DTIC
S ELECTE D
MAY 18 1990
D CS D

February 1990

Supported by:
U.S. Army Medical Research and
Development Command
Fort Detrick, Frederick, MD 21701-5012

Project Order No. 84PP4819

*Original contains color.
Please: All DTIC reproductions
will be in black and
white.

Pacific Northwest Laboratory
P.O. Box 999
Richland, Washington 99352
Operated for the U.S. Department of Energy
by Battelle Memorial Institute

Approved for public release;
distribution unlimited

The findings of this report are not to be construed as
official Department of the Army positions unless so
designated by other authorized documents

90 05 17 097

DISCLAIMER

This report was prepared as an account of work sponsored by an agency of the United States Government. Neither the United States Government nor any agency thereof, nor Battelle Memorial Institute, nor any of their employees, makes any warranty, expressed or implied, or assumes any legal liability or responsibility for the accuracy, completeness, or usefulness of any information, apparatus, product, or process disclosed, or represents that its use would not infringe privately owned rights. Reference herein to any specific commercial product, process, or service by trade name, trademark, manufacturer, or otherwise, does not necessarily constitute or imply its endorsement, recommendation, or favoring by the United States Government of any agency thereof, or Battelle Memorial Institute. The views and opinions of authors expressed herein do not necessarily state or reflect those of the United States Government or any agency thereof.

PACIFIC NORTHWEST LABORATORY
operated by
BATTELLE MEMORIAL INSTITUTE
for the
UNITED STATES DEPARTMENT OF ENERGY
under Contract DE-AC06-76RLO 1830

Printed in the United States of America

Available to DOE and DOE contractors from the
Office of Scientific and Technical Information, P.O. Box 62, Oak Ridge, TN 37831;
prices available from (615) 576-8401. FTS 626-8401.

Available to the public from the National Technical Information Service,
U.S. Department of Commerce, 5285 Port Royal Rd., Springfield, VA 22161.

NTIS Price Codes, Microfiche A01

Printed Copy

Price Code	Page Range	Price Code	Page Range
A02	1- 10	A15	326-350
A03	11- 50	A16	351-375
A04	51- 75	A17	376-400
A05	76-100	A18	401-425
A06	101-125	A19	426-450
A07	126-150	A20	451-475
A08	151-175	A21	476-500
A09	176-200	A22	501-525
A10	201-225	A23	526-550
A11	226-250	A24	551-575
A12	251-275	A25	576-600
A13	276-300	A99	601-Up
A14	301-325		

**EVALUATE AND CHARACTERIZE MECHANISMS CONTROLLING
TRANSPORT, FATE, AND EFFECTS OF ARMY SMOKES IN THE
AEROSOL WIND TUNNEL**

**Subtitle: Transport, Transformations, Fate, and Terrestrial Ecological
Effects of Mixed Obscurant Smokes**

Final Report

Dominic A. Cataldo, Ph.D
Michael W. Ligothe, M.S.
Harvey Bolton, Jr., Ph.D
Robert J. Fellows, Ph.D

Peter Van Voris, Ph.D
Bruce D. McVeety, Ph.D
Shu-mei W. Li, M.S.
Kristin M. McFadden, M.S.



February 1990

Supported by:

**U.S. Army Medical Research and
Development Command
Fort Detrick, Frederick, MD 21701-5012**

Project Order No. 84PP4819

**Pacific Northwest Laboratory
Post Office Box 999
Richland, Washington 99352
*Operated for the U.S. Department of Energy
by Battelle Memorial Institute***

**Project Officer: Wayne R. Mitchell
U.S. Army Biomedical Research and
Development Laboratory
Fort Detrick, Frederick, MD 21701-5010**

Approved for public release;
distribution unlimited

The findings of this report are not to be construed as
an official Department of the Army position unless so
designated by other authorized documents

Accession For	
NTIS CRA&I	<input checked="" type="checkbox"/>
DTIC TAB	<input type="checkbox"/>
Unannounced	<input type="checkbox"/>
Justification	
By _____	
Distribution /	
Availability Codes	
Dist	Avail and/or Special
A-1	

REPORT DOCUMENTATION PAGE

Form Approved
OMB No. 0704-0188

1a. REPORT SECURITY CLASSIFICATION Unclassified		1b. RESTRICTIVE MARKINGS	
2a. SECURITY CLASSIFICATION AUTHORITY		3. DISTRIBUTION/AVAILABILITY OF REPORT Approved for public release; distribution unlimited	
2b. DECLASSIFICATION/DOWNGRADING SCHEDULE		4. PERFORMING ORGANIZATION REPORT NUMBER(S)	
4. PERFORMING ORGANIZATION REPORT NUMBER(S)		5. MONITORING ORGANIZATION REPORT NUMBER(S)	
6a. NAME OF PERFORMING ORGANIZATION Pacific Northwest Laboratory	6b. OFFICE SYMBOL (If applicable)	7a. NAME OF MONITORING ORGANIZATION U.S. Biomedical Research and Development Laboratory	
6c. ADDRESS (City, State, and ZIP Code) P.O. Box 999 Richland, WA 99352		7b. ADDRESS (City, State, and ZIP Code) Fort Detrick Frederick, Maryland 21701-5010	
8a. NAME OF FUNDING/SPONSORING ORGANIZATION U.S. Army Medical Research & Development Command	8b. OFFICE SYMBOL (If applicable)	9. PROCUREMENT INSTRUMENT IDENTIFICATION NUMBER Project Order No. 84PP4819	
8c. ADDRESS (City, State, and ZIP Code) Fort Detrick Frederick, Maryland 21701-5012		10. SOURCE OF FUNDING NUMBERS	
		PROGRAM ELEMENT NO. 62720A	PROJECT NO. 3E1- 62720A835
		TASK NO. AA	WORK UNIT ACCESSION NO. 013
11. TITLE (Include Security Classification) Evaluate and Characterize Mechanisms Controlling Transport, Fate, and Effects of Army Smokes in the Aerosol Wind Tunnel			
12. PERSONAL AUTHOR(S) Dominic A. Cataldo, Ph.D.; Michael W. Ligotke, M.S.; Harvey Bolton, Jr., Ph.D. Robert J. Fellows, Ph.D.; Peter Van Voris, Ph.D.; Bruce D. McVeety; Shu-mei W. Li; K.M. McFadden			
13a. TYPE OF REPORT Final Report	13b. TIME COVERED FROM 1987 to 1988	14. DATE OF REPORT (Year, Month, Day) February 1990	15. PAGE COUNT 194
16. SUPPLEMENTARY NOTATION Subtitle: Transport, Transformations, Fate, and Terrestrial Ecological Effects of Mixed Obscurant Smokes			
17. COSATI CODES		18. SUBJECT TERMS (Continue on reverse if necessary and identify by block number)	
FIELD	GROUP	RA III; Red Phosphorus, White Phosphorus, Fog Oil, and Hexachloroethane Smokes, Environmental Fate, Persistence, Vegetation Effects, Soil Effects, Earthworms, Soil Microbes.	
07	02		
07	03		
19. ABSTRACT (Continue on reverse if necessary and identify by block number) This report assesses the environmental fate and effects of mixed obscurant smokes comprised of white phosphorus (WP), fog oil (FO) and hexachloroethane (HC) smokes. Overall, based on the environmental fate and effects of the individual obscurant smokes investigated previously, (Van Voris et al. 1987; Cataldo et al. 1989a and b), significant synergistic effects are indicated in some instances. The chemistry of the FO and HC smokes following deposition to surfaces was generally consistent with their reported individual behavior. However, with WP, the combustion products or rates of conversion of polyphosphates to phosphate appear to be altered by the presence of FO and HC+FO, resulting in elevated levels of non-phosphate P. This may have influenced the higher than expected toxicity of mixed smokes containing WP. Similarly, there may be a potential interaction of HC-derived Cl ₂ with the polyphosphates from WP combustion, which may influence the fate and effects of these mixed smokes.			
(Continued on reverse side).			
20. DISTRIBUTION/AVAILABILITY OF ABSTRACT <input type="checkbox"/> UNCLASSIFIED/UNLIMITED <input checked="" type="checkbox"/> SAME AS RPT. <input type="checkbox"/> DTIC USERS		21. ABSTRACT SECURITY CLASSIFICATION Unclassified	
22a. NAME OF RESPONSIBLE INDIVIDUAL Mrs. Virginia M. Miller		22b. TELEPHONE (Include Area Code) 301/663-7325	22c. OFFICE SYMBOL SGRD-RMI-S

Abstract (Cont.)

Deposition velocities, and thus dose rates, for the mixed smoke components (P, Zn, and Cl) were generally similar to those for single smoke exposures. Deposition velocities were highest for ponderosa pine and lowest with tall fescue; these ranged from 0.003 to 0.4 cm/s and were dependent on wind speed. Calculated values for mixed-smoke components were similar to those reported previously for red phosphorus/white phosphorus (Van Voris et al. 1987), fog oil (Cataldo et al. 1989a), and hexachloroethane smokes (Cataldo et al. 1989b).

The effects of smoke mixtures on soil chemistry were not judged significant, and likely result from additive effects of smoke acidity, anion imbalance, and secondary effects on microbial processes.

In the mixed-smoke scenarios employing HC/FO/WP, contact phytotoxicity was greater than expected based on published single-smoke exposures. All plant species exhibited moderate to severe damage at mass loading levels comparable, or less than, those used in single smoke exposure tests. This likely results from an additive effect of contaminants. Plant sensitivity to mixed smokes was bush bean > sagebrush > ponderosa pine > tall fescue. Results indicate that much of the phytotoxicity is due to WP smoke constituents, and could be simulated by both pH and P₂O₅, but not long-chain polyphosphates.

Growth and regrowth of exposed tall fescue plants indicated no significant residual effects based on biomass production. Similarly, seeding and growth of tall fescue on soils contaminated with mixed smokes showed no effects on either germination or dry matter production.

Soil respiration was reduced in soils exposed to HC and WP containing smokes; however, recovery was evident after 4 weeks. Both phosphatase and dehydrogenase activity was depressed following exposure to mixed smokes, but again, recovery was evident after 4 weeks. Although the population of Nitrosomonas sp. in soils was not dramatically affected in soils exposed to mixed smokes, the population of Nitrobacter sp. was reduced in Burbank soil. Results indicate that effects were most pronounced for soils exposed to smokes containing HC, and less for soils exposed to WP smokes.

No effects were noted on earthworm survival in soils containing any of the mixed smoke combinations.

FOREWARD

Opinions, interpretations, conclusions and recommendations are those of the author and are not necessarily endorsed by the U.S. Army.

 X Where copyrighted material is quoted, permission has been obtained to use such material.

 X Where material from documents designated for limited distribution is quoted, permission has been obtained to use the material.

 X Citations of commercial organizations and trade names in this report do not constitute an official Department of the Army endorsement or approval of the products or services of these organizations.

 X In conducting research using animals, the investigator(s) adhered to the "Guide for the Care and Use of Laboratory Animals," prepared by the committee on Care of Use of Laboratory Animals of the Institute of Laboratory Animal Resources, National Research Council (NIH Publication No. 86023, Revised 1985).

 X For the protection of human subjects, the investigator(s) have adhered to policies of applicable Federal Law 45CFR46.

_____ 3/21/80
PI Signature Date

EXECUTIVE SUMMARY

The objective of this study was to determine whether the use of mixed obscurant smokes for training purposes presents an added environmental impact compared with the use of individual smokes. The environmental fate and effect of the individual obscurant smokes, red phosphorus/white phosphorus (RP/WP) (Van Voris et al. 1987), fog oil (FO) (Cataldo et al. 1989a), and hexachloroethane (HC) (Cataldo et al. 1989b) previously have been assessed. In summary, of the individual smokes evaluated, only the phosphorus smokes resulted in moderate to severe plant damage from contact toxicity and exhibited moderate residual plant effects. Both HC and phosphorus smokes had adverse effects on the functional performance of soil microbial activity. Fog oil had little effect on plants or soil microbes. No significant adverse effects on soil chemistry or soil invertebrates were observed for any of the smokes. The present study attempts to establish whether mixed-smoke scenarios, employing these three smokes in sequential combination, could have a synergistic impact on the environs in which they are employed for training. The principal mixed smoke scenario involved sequential exposure to HC, FO, and WP. Additional scenarios involved use of FO/WP and HC/FO. Air concentrations were set at those levels normally effective in the field and were 500 to 600 mg/m³ for FO and HC, and 2000 mg/m³ for WP. Exposure durations ranged from 2 to 4 h for each smoke. Thus, effects and/or impacts can be compared with those reported for individual smokes.

Mixed-smoke scenarios involving FO and HC smokes resulted in airborne chemistries and deposition products generally consistent with their reported individual behavior. However, with WP, the combustion products or rates of conversion of polyphosphates to phosphate appear to be altered by the presence of FO and HC+FO, resulting in elevated levels of non-phosphate P. This may have influenced the higher-than-expected toxicity of mixed smokes containing WP. Similarly, there may be a potential interaction of HC-derived Cl⁻ with the polyphosphates from WP combustion, which may influence the fate and effects of these mixed smokes.

Deposition velocities, and subsequent mass loading of the mixed smoke components P, Zn, and Cl were generally similar to those for single-smoke exposures. Deposition velocities were highest for ponderosa pine and lowest for tall fescue; these ranged from 0.003 to 0.4 cm/s and were dependent on wind speed.

The effects of smoke mixtures on soil chemistry were not judged significant; however, several important changes occurred with mixed smokes. The anion/cation balances for soil extracts indicate the likely presence of polyphosphates in excess of those observed for P smokes alone. This would indicate that the presence of other smoke constituents may slow the rate of decomposition of polyphosphates. Trace metal solubilization in soils exposed to mixed smokes likely results from increased additive acidity. Fluctuations in nitrogen pools likely result from effects of smoke constituents on microbial populations.

Mixed-smoke application involving HC/FO/WP resulted in greater contact phytotoxicity than expected based on published single-smoke exposures. All plant species exhibited moderate to severe damage at mass loading levels comparable to, or less than, those used in single-smoke exposure tests. Plant sensitivity to mixed smokes was bush bean > sagebrush > ponderosa pine > tall fescue. In alternate scenario tests involving WP/FO, damage to all plants was also severe. Cumulative dose tests using HC/FO resulted in severe damage only to bush bean and sagebrush, and were comparable to those expected based on single-smoke exposures. Results indicated that much of the phytotoxicity is from WP smoke constituents. Attempts to resolve the source of phytotoxicity, through application of specific WP smoke constituents indicated that foliar damage can be elicited by both pH and P₂O₅, but not long-chain polyphosphates.

Growth and regrowth of exposed tall fescue plants indicated no significant residual effects based on biomass production. Similarly, seeding and growth of tall fescue on soils contaminated with mixed smokes showed no effects on either germination or dry matter production.

Soils exposed to mixed smokes were evaluated for effects on key microbial processes, including respiration, dehydrogenase activity, phosphatase activity, and nitrification. Soil respiration was reduced in soils exposed to HC and WP containing smokes; however, recovery was evident after 4 weeks. Both phosphatase and dehydrogenase activity was depressed following exposure to mixed smokes, but again, recovery was evident after 4 weeks. Although the population of Nitrosomonas sp. in soils was not dramatically affected in soils exposed to mixed smokes, the population of Nitrobacter sp. was reduced in Burbank soil. Results indicated that effects were most pronounced for soils exposed to smokes containing HC and less for soils exposed to WP smokes.

No effects were noted on earthworm survival in soils containing any of the mixed-smoke combinations.

Overall, the major environmental impacts observed with mixed obscurant smokes result from combustion products of WP; this observation is consistent with previously reported toxicity resulting from use of individual smokes RP/WP, FO, and HC (Van Voris et al. 1987; Cataldo et al. 1988, 1989a and b). It is likely that soils exposed to mixed smokes are most affected by pH, and possibly polyphosphates produced in combustion of phosphorus smokes. Plant effects appear to result principally from the pH of phosphorus smokes, and likely P₂O₅. Plant effects are not persistent based on residual and indirect effect studies. Microbial processes appear to be adversely affected both by Zn associated with HC smoke and possibly the polyphosphoric acid associated with WP and RP smokes. In general, FO smokes have a beneficial effect on microbial processes.

TABLE OF CONTENTS

	REPORT DOCUMENTATION PAGE	iii
	FOREWORD.....	v
	EXECUTIVE SUMMARY	vii
1.0	INTRODUCTION	1.1
1.1	FATE AND EFFECTS OF PHOSPHORUS SMOKES	1.2
1.1.1	Physical and Chemical Characteristics of Phosphorus Smoke.....	1.2
1.1.2	Impact of Phosphorus Smokes on Soil Chemistry.....	1.3
1.1.3	Foliar Contact Toxicity: Direct Effects.....	1.3
1.1.4	Residual and Indirect Soil/Plant Effects.....	1.4
1.1.5	Impact of Phosphorus Smokes on Soil Microflora	1.4
1.2	FATE AND EFFECTS OF FOG OIL SMOKES.....	1.4
1.2.1	Physical and Chemical Characteristics of Fog Oil Smoke.....	1.4
1.2.2	Foliar Contact Toxicity: Direct Effects.....	1.5
1.2.3	Residual and Indirect Soil/Plant Effects.....	1.5
1.2.4	Impact of Fog Oil Smokes on Soil Microflora.....	1.6
1.2.5	Soil Invertebrate Effects.....	1.6
1.3	FATE AND EFFECTS OF HEXACHLOROETHANE SMOKES	1.6
1.3.1	Physical and Chemical Characteristics of HC Smoke.....	1.6
1.3.2	Foliar Contact Toxicity: Direct Effects.....	1.7
1.3.3	Residual and Indirect Soil/Plant Effects.....	1.7
1.3.4	Impact of HC Smokes on Soil Microflora.....	1.7
1.3.5	Soil Invertebrate Effects.....	1.8
1.4	MIXED-SMOKE SCENARIOS.....	1.8
2.0	MATERIALS AND METHODS.....	2.1
2.1	AEROSOL WIND TUNNEL RESEARCH FACILITY.....	2.1
2.1.1	Environmental Wind Tunnel	2.3
2.1.2	Wind Tunnel Test Section.....	2.3
2.1.3	Aerosol Instrumentation.....	2.5
2.1.4	Analytical Chemistry.....	2.6
2.2	EXPOSURE CONDITIONS.....	2.6
2.2.1	Exposure Environment	2.7
2.2.2	Mixed-Smoke Test Series.....	2.7
2.2.3	Test Procedures and Measured Conditions.....	2.8
2.3	SMOKE (AEROSOL) GENERATION	2.12
2.3.1	Test Materials and Generation Procedures.....	2.13

2.3.2	Aerosol Generation	2.19
2.4	SMOKE (AEROSOL) CHARACTERIZATION	2.19
2.4.1	Aerosol Mass Concentration	2.20
2.4.2	Mixed-Smoke Composition	2.25
2.4.3	Particle Size Distribution	2.28
2.4.4	Particle Deposition Velocity	2.29
2.5	SMOKE CHEMICAL CHARACTERIZATION	2.30
2.5.1	Characterization Methods	2.30
2.5.2	Soil Treatments and Characterization	2.31
2.6	PLANT AND SOIL SELECTION AND CULTIVATION	2.33
2.6.1	Plant Selection and Cultivation	2.33
2.6.2	Soil Selection and Characteristics	2.35
2.7	PLANT/SOIL MEASUREMENTS	2.35
2.7.1	Foliar Contact Toxicity Responses	2.35
2.7.2	Photosynthetic Measurements	2.36
2.7.3	Indirect Plant Effects	2.37
2.7.4	Quantitation of Exposure/Dose	2.38
2.7.5	Post-Exposure Simulated Rainfall	2.39
2.8	SOIL MICROBIOLOGICAL MEASUREMENTS	2.39
2.9	SOIL INVERTEBRATE ASSAY	2.43
3.0	RESULTS AND DISCUSSION	3.1
3.1	SMOKE (AEROSOL) CHARACTERIZATION	3.1
3.1.1	Aerosol Mass Concentration	3.1
3.1.2	Mixed-Smoke Composition	3.6
3.1.3	Particle Size Distribution	3.10
3.1.4	Deposition Velocity to Suspended Surrogate Surfaces	3.15
3.1.5	Quantification of Relative Applied Doses	3.17
3.2	CHEMICAL CHARACTERISTICS OF MIXED SMOKES	3.18
3.2.1	Organic Characterization of Aerosols	3.18
3.2.2	Inorganic Characterization of Aerosols	3.18
3.2.3	Mass Loading and Deposition Velocity to Receptor Surfaces ..	3.24
3.2.4	Interaction of Mixed Smokes with Soils	3.40
3.3	TERRESTRIAL VEGETATION EFFECTS	3.55
3.3.1	Vegetation Mass Loading and Foliar Retention of Mixed-Smoke Components	3.55
3.3.2	Mass Loading of Mixed-Smoke Constituents to Exposed Soils	3.67

TABLE OF CONTENTS (Cont.)

3.3.3	Contact Phytotoxicity of Mixed Smokes Deposited to Foliar Surfaces	3.70
3.3.4	Metabolic Responses to Mixed Smokes Wind Speed Exposures	3.82
3.3.5	Contact Toxicity of Phosphorus Smoke Constituents.....	3.87
3.3.6	Residual Effects of Mixed Smokes on Dry Matter Production of Foliar-Exposed Tall Fescue.....	3.93
3.3.7	Indirect Soil Effects on Growth of Tall Fescue Grown on Soils Contaminated With Mixed Smokes From WS/RF TESTS.....	3.96
3.4	EARTHWORM BIOASSAY MIXED-SMOKE EFFECTS.....	3.100
3.5	SOIL MICROBIAL EFFECTS	3.103
3.5.1	Soil Respiration.....	3.104
3.5.2	Soil Dehydrogenase Activity	3.105
3.5.3	Soil Nitrifying Bacteria	3.111
4.0	CONCLUSIONS	4.1
5.0	REFERENCES	5.1

LIST OF FIGURES

FIGURE 2.1	Pacific Northwest Laboratory Aerosol Wind Tunnel.....	2.2
FIGURE 2.2	Closed-Loop Wind Tunnel, Aerosol Generation and Injection and Primary Test Section.....	2.4
FIGURE 2.3	Miniature Hexachloroethane (HC) Smoke Pot Aerosol Generator for Computer-Controlled Wind Tunnel Experiments.....	2.13
FIGURE 2.4	Temperature-Controlled Fog Oil (FO) Aerosol Generator.....	2.14
FIGURE 2.5	White Phosphorus (WP) Aerosol Generator. Computer Control Was Used to Aspirate Bath Water and Then Ignite Pure WP.....	2.15
FIGURE 2.6	Hexachloroethane Pot Generating Smoke in the Aerosol Buffer Chamber.....	2.17
FIGURE 2.7	Transmissometer Calibrations for Four Selected Mixed-Smoke Tests.....	2.24
FIGURE 2.8	Time History of HC Aerosol Residual Zinc Concentration During Subsequent (FO and WP) Portions of Mixed-Smoke Aerosol Tests.....	2.28
FIGURE 2.9	Schematic Diagram of Gas Exchange System Used in Making Net Photosynthetic and Dark Respiration Measurements.....	2.38
FIGURE 2.10	Apparatus for Simulating Rainfall Conditions.....	2.40
FIGURE 3.1	Aerosol Mass Concentration During Tests MS-7 and MS-8 (Cumulative Dose Series--HC Generation During First Third, FO During Second Third, and WP During Final Third).....	3.3
FIGURE 3.2	Aerosol Mass Concentration During Tests MS-14 and MS-15 (Cumulative Dose Series--FO Generation During First Half, WP Generation During Last Half).....	3.4
FIGURE 3.3	Aerosol Mass Concentration During Tests MS-16 and MS-17 (Cumulative Dose Series--HC Generation During First Half, to FO Generation During Last Half).....	3.5
FIGURE 3.4	Aerosol Particle Size Distributions for HC, FO, and WP Components of Two Mixed-Smoke Wind Speed Exposure Series Tests: MS-5 (2.73 m/s) and MS-6 (54.57 m/s).....	3.12

LIST OF FIGURES (Cont.)

FIGURE 3.5	Aerosol Particle Size Distributions for HC, FO, and WP Components of Two Mixed-Smoke Cumulative Dose Exposure Series Tests: MS-9 and MS-10	3.13
FIGURE 3.6	Deposition Velocities (V_d) to Horizontally Suspended 47-mm-dia Glass Fiber Deposition Coupons.....	3.16
FIGURE 3.7	Deposition Velocities (V_d) of Components of Mixed-Smoke Aerosols to Horizontally Suspended 47-mm-dia Glass Fiber Deposition Coupons	3.16
FIGURE 3.8	Hydrolysis of Polyphosphates to Phosphate Versus Time Held in the Dry State.....	3.28
FIGURE 3.9	Regression Analysis of Deposition Velocities for Ponderosa Pine and Sagebrush.....	3.60
FIGURE 3.10	Regression Analysis of Deposition Velocities for Bush Bean and Tall Fescue.....	3.61
FIGURE 3.11	Net Photosynthesis and Dark Respiration in $\mu\text{MOL CO}_2/\text{s}$ for Ponderosa Pine Plants Before and After Exposure to Mixed Smokes at: A) 2 mph; B) 4 mph; C) 6 mph; and D) 10 mph.....	3.83
FIGURE 3.12	Net Photosynthesis and Dark Respiration in $\mu\text{MOL CO}_2/\text{s}$ for Tall Fescue Plants Before and After Exposure to Mixed Smokes at: A) 2 mph; B) 4 mph; C) 6 mph; and D) 10 mph.....	3.85
FIGURE 3.13	Net Photosynthesis and Dark Respiration in $\mu\text{MOL CO}_2/\text{s}$ for Exposed: A) Ponderosa Pine, B) Tall Fescue, MS/CD Plants (MS-7-8), and Non-Exposed Control Plants Before and After First Exposure Date.....	3.86
FIGURE 3.14	Net Photosynthesis and Dark Respiration in $\mu\text{MOL CO}_2/\text{s}$ for Exposed: A) Ponderosa Pine, B) Tall Fescue, MS/CD Plants (MS-9-10), and Non-Exposed Control Plants Before and After First Exposure Date	3.88
FIGURE 3.15	Net Photosynthesis and Dark Respiration in $\mu\text{MOL CO}_2/\text{s}$ for Exposed: A) Ponderosa Pine, and B) Tall Fescue, MS/CD Single FO Exposure (MS-13) Plants and Non-Exposed Control Plants Before and After First Exposure Date.....	3.89

LIST OF FIGURES (Cont.)

FIGURE 3.16	Net Photosynthesis and Dark Respiration in $\mu\text{MOL CO}_2/\text{s}$ for Exposed: A) Ponderosa Pine, B) Tall Fescue, MS/CD WP/FO Exposure (MS-14-15) Plants and Non-Exposed Control Plants Before and After First Exposure Date.....	3.90
FIGURE 3.17	Net Photosynthesis and Dark Respiration in $\mu\text{MOL CO}_2/\text{s}$ for Exposed: A) Ponderosa Pine, and B) Tall Fescue, MS/CD HC/FO Exposure (MS-16-17) Plants and Non-Exposed Control Plants Before and After First Exposure Date.....	3.91
FIGURE 3.18	Effect of Mixed-Smoke Exposure at a Wind Speed of 4.57 m/s (Test MS-6) on Palouse Soil Respiration.	3.105
FIGURE 3.19	Effect of Cumulative Dose of Mixed-Smoke on Soil Respiration.....	3.106
FIGURE 3.20	Dehydrogenase Activity (Expressed as % of the Control) in Soil Exposed to a Cumulative Dose of Mixed Smokes.....	3.108
FIGURE 3.21	Phosphatase Activity (Expressed as % of Control) in Soil Exposed to Cumulative Dose Mixed Smokes.....	3.112
FIGURE 3.22	<i>Nitrosomonas sp.</i> Population in Soils Exposed to a Cumulative Dose of Mixed Smokes.....	3.115
FIGURE 3.23	<i>Nitrobacter sp.</i> Population in Soils Exposed to a Cumulative Dose of Mixed Smokes.....	3.116

LIST OF TABLES

TABLE 2.1	Description of Mixed-Smoke Test Series.....	2.8
TABLE 2.2	Environmental Conditions, Wind Speed, and Exposure Duration During Mixed-Smoke Obscurant Tests.....	2.10
TABLE 2.3	Temperature and Relative Humidity Averages and Fluctuations During Mixed-Smokes Obscurant Tests	2.11
TABLE 2.4	Wind Speed Averages and Fluctuations During Mixed-Smokes Obscurant Tests	2.12
TABLE 2.5	Obscurant Smoke Sequence and Generation Procedures for Mixed-Smoke Tests.....	2.20
TABLE 2.6	Laser Transmissometer Calibration Relationships for Mixed-Smoke Obscurant Aerosol Tests	2.22
TABLE 2.7	Comparison of Measured and Transmissometer-Derived (Calculated) Aerosol Mass Concentrations for Mixed-Smoke Obscurant Tests	2.25
TABLE 2.8	Comparison of Measured and Transmissometer-Derived (Calculated) Aerosol Mass Concentrations for Test MS-16.....	2.26
TABLE 2.9	Selected Properties of Soils Used in Aerosol Exposures.....	2.33
TABLE 2.10	Coding for Modified Daubenmire Rating Scale and Associated Phytotoxicity Symptoms.....	2.36
TABLE 3.1	Intervals of HC, FO, and WP as the Primary Components of Generated Aerosols During Mixed-Smoke Obscurant Tests.....	3.2
TABLE 3.2	Average Actual Aerosol Mass Concentration (cm) During Each Interval of Mixed-Smoke Obscurant Tests (± 1 STD).....	3.2
TABLE 3.3	Average <u>Aerosol-Specific</u> Aerosol Mass Concentration (CM) During Each Interval of Mixed-Smoke Obscurant Tests	3.6
TABLE 3.4	Average <u>Chemical-Specific</u> Aerosol, Desiccated, and Component Mass Concentrations (cm) During Each Interval of Mixed-Smoke Obscurant Tests.....	3.7
TABLE 3.5	Chemical Composition of Mixed-Smoke Aerosols During Specific Intervals of Several Mixed-Smoke Obscurant Tests	3.9
TABLE 3.6	Aerosol Particle Size Distribution Results for Mixed-Smoke Tests	3.10

LIST OF TABLES (Cont.)

TABLE 3.7	Deposition Velocities to Suspended Glass Fiber Filter (GFF) Coupons During Mixed-Smoke Tests.....	3.15
TABLE 3.8	Calculated Relative Dose Terms, in mg/m ² , for Major Components of Mixed-Smoke Aerosols.....	3.18
TABLE 3.9	Analysis of Inorganic Chemical Constituents of Mixed-Smoke Aerosol Filter Leachates.....	3.19
TABLE 3.10	Analysis of Inorganic Chemical Constituents of Mixed-Smoke Aerosol Filter Leachates.....	3.21
TABLE 3.11	Estimation of Fog Oil Component in the Aerosol by Chemical Approximations	3.22
TABLE 3.12	Analysis of Inorganic Chemical Constituents of Mixed-Smoke Aqueous Impingers	3.23
TABLE 3.13	Inorganic Chemical Constituents of Mixed-Smoke Deposition Coupon Leachates	3.26
TABLE 3.14	Mass Loading and Deposition Velocities Based on Mixed-Smoke Deposition onto Wet Surfaces.....	3.30
TABLE 3.15	Mass Loading and Deposition Velocities Based on Mixed-Smoke Deposition onto Dry Surfaces	3.31
TABLE 3.16	Mass Loading on Soil Coupons, Based on Aqueous Dissolution	3.35
TABLE 3.17	Summary of Deposition Velocities for Inorganic Constituent of Mixed Smoke Aerosols onto Diverse Surfaces.....	3.38
TABLE 3.18	Summary of Deposition Velocities From Mixed-Smoke Tests Compared to Single-Smoke Exposures: P Depositions, and HC Depositions.....	3.40
TABLE 3.19	Phosphate Polymerization Required for Anion/Cation Balance Soils Exposed to Mixed Smokes (N=2).....	3.42
TABLE 3.20	Inorganic Chemical Analysis of Mixed-Smoke Exposed Soil Leachate Solutions With Time: Burbank.....	3.44
TABLE 3.21	Inorganic Chemical Analysis of Mixed-Smoke Exposed Soil Leachate Solutions With Time: Maxey Flats	3.47
TABLE 3.22	Inorganic Chemical Analysis of Mixed-Smoke Exposed Soil Leachate Solutions With Time: Palouse	3.50

LIST OF TABLES (Cont.)

TABLE 3.23	Inorganic Chemical Analysis of Mixed-Smoke Exposed Soil Leachate Solutions With Time: Yamac	3.53
TABLE 3.24	Foliar Mass Loading of Zn (HC), Phosphorous (WP) and Fog Oil From Mixed-Smoke RF/WS Tests (MS-3-6).	3.56
TABLE 3.25	Percent Foliar Retention of Mixed-Smoke Components Following a Post-Exposure Leaching/Simulated Rainfall in MS RF/WS Tests.....	3.58
TABLE 3.26	Deposition Velocities (V_d) of Zn (HC), Phosphorous (WP) and Fog Oil (FO) to Vegetation From Mixed-Smoke RF/WS Tests	3.59
TABLE 3.27	Average Foliar Mass Loading ($\mu\text{g}/\text{cm}^2$) of Phosphorous (WP) and Zinc (HC) on Vegetation Surfaces During Mixed-Smoke/Cumulative Dose (MS/CD) Experiments	3.63
TABLE 3.28	Average Foliar Mass Loading ($\mu\text{g}/\text{cm}^2$) of Fog Oil (FO) Following an Exposure (MS-13) Simulating the Conditions of the Fog Oil Portion of the Combined MS/CD Tests.....	3.64
TABLE 3.29	Deposition Velocities of Zn (HC), Phosphorous (WP), and Fog Oil (FO) to Vegetation From Mixed-Smoke Cumulative Dose and Special Fog Oil Tests	3.65
TABLE 3.30	Average Foliar Mass Loading ($\mu\text{g}/\text{cm}^2$) of Phosphorous (WP) on Vegetation Surfaces During Mixed-Smoke Cumulative Dose (MS/CD) Experiments (14-15)	3.66
TABLE 3.31	Average Foliar Mass Loading ($\mu\text{g}/\text{cm}^2$) of Zinc (HC) on Vegetation Surfaces During Mixed-Smoke Cumulative Dose (MS/CD) Experiments (16-17).....	3.67
TABLE 3.32	Soil Mass Loading for Burbank and Maxey Flats Soils Following Exposure to MS RF/WS Tests.....	3.68
TABLE 3.33	Average Soil Mass Loading ($\mu\text{g}/\text{cm}^2$) of Phosphorous (WP) and Zinc (HC) During Mixed-Smoke Cumulative Dose (MS/CD) Experiments (MS-7-8 and MS-9-10) (N = 3), and Average Soil Mass Loading ($\mu\text{g}/\text{cm}^2$) of Fog Oil (FO) During Separate Fog Oil Exposure as Part of the MS/CD Exposures (MS-13)	3.69
TABLE 3.34	Average Soil Mass Loading ($\mu\text{g}/\text{cm}^2$) of Phosphorous (WP) During Mixed-Smoke Cumulative Dose (MS/CD) Experiments (14-15)	3.70

LIST OF TABLES (Cont.)

TABLE 3.35	Average Soil Mass Loading ($\mu\text{g}/\text{cm}^2$) of Zinc (HC) During Mixed-Smoke Cumulative Dose (MS/CD) Experiments (16-17)	3.70
TABLE 3.36	Plant Symptomology to Mixed-Smoke Exposures in Wind Speed Tests MS-3 through MS-6	3.72
TABLE 3.37	Plant Symptomology to Mixed-Smoke Exposures in Cumulative Dose Experiments MS-7-8.....	3.76
TABLE 3.38	Plant Symptomology to Mixed-Smoke Exposures in Cumulative Dose Experiments MS-9-10.....	3.77
TABLE 3.39	Plant Symptomology in Fog Oil Experiment MS-13.....	3.79
TABLE 3.40	Plant Symptomology to Mixed-Smoke Exposures in Cumulative Dose Experiments MS-14-15	3.80
TABLE 3.41	Plant Symptomology to Mixed-Smoke Exposures in Cumulative Dose Experiments MS-16-17	3.81
TABLE 3.42	Effects of Direct Follar Application ^(a) of Polyphosphate Solutions of Varying Chain Lengths to Bush Bean	3.93
TABLE 3.43	Effects of Mixed-Smoke RF/WS Tests on the Regrowth (Dry Matter Production) of Exposed ^(a) and Exposed/Leached ^(b) Tall Fescue at 30 and 60 Days Post-Exposure....	3.94
TABLE 3.44	Effects of Cumulative MS Exposure (MS-7-8; MS-9-10) and Separate FO Exposure (MS-13) on Regrowth (Dry Matter Production) in Tall Fescue	3.95
TABLE 3.45	Effects of Mixed-Smoke Tests With Phosphorous (WP/FO, MS-14-15) or Zinc (HC/FO, MS-16-17) With Fog Oil (FO) on the Regrowth (Dry Matter Production) of Tall Fescue at 30 and 60 Days Post-Exposure	3.96
TABLE 3.46	Indirect Effects of Mixed Smokes Zinc (HC), Phosphorous (WP), and Fog Oil (FO) Deposited to Soils in the WS/RF Test Series (MS-3-6) on the Growth of Tall Fescue.....	3.97
TABLE 3.47	Indirect Effects of Mixed Smokes Deposited to Soils Following Cumulative Dose (MS-7-8 and MS-9-10) and Special FO MS-13) Exposures on the Growth of Tall Fescue.....	3.98
TABLE 3.48	Indirect Effects of Mixed Smokes Phosphorous (WP, MS 14-15) and Fog Oil Deposited to Soils in the MS-CD Test Series on the Growth of Tall Fescue	3.99

LIST OF TABLES (Cont.)

TABLE 3.49	Indirect Effects of Mixed Smokes Zinc (HC) (MS-16-17) and Fog Oil (FO) Deposited to the Soils in the MS-CD Test on the Growth of Tall Fescue	3.100
TABLE 3.50	Influence of Soil-Deposited Phosphorous (P), Zn (HC), and Fog Oil (FO) From Mixed-Smoke RF/WS Tests on the Survival of Earthworms (<i>Eisenia foetida</i>).....	3.101
TABLE 3.51	Influence of Soil-Deposited Phosphorous (WP), Zinc (HC), and Fog Oil (FO) From Mixed-Smoke Cumulative Dose (MS/CD) Tests on the Survival of Earthworms (<i>Eisenia foetida</i>).....	3.102
TABLE 3.52	Influence of Soil Deposited Phosphorous (WP) and Zinc (HC) From Mixed-Smoke Cumulative Dose (MS/CD) Tests on the Survival of Earthworms (<i>Eisenia foetida</i>).....	3.102
TABLE 3.53	Dehydrogenase Activity in Soil Exposed to Mixed Smokes in the Range-Finding/Wind Speed Test Series	3.109
TABLE 3.54	Phosphatase Activity in Soil Exposed to Mixed Smokes (Range-Finding/Wind Speed Test Series).....	3.110
TABLE 3.55	Effect of Mixed Smokes (Range Finding/Wind Speed Tests) on Soil <i>Nitrosomonas sp.</i> Population	3.113
TABLE 3.56	Effect of Mixed Smokes (Range-Finding/Wind Speed Tests) on Soil <i>Nitrobacter sp.</i> Population.....	3.113

1.0 INTRODUCTION

The U.S. Army has deployed a number of smokes and obscurants to visually mask the movement of troops and vehicles during combat. Effective training scenarios for the armed forces require that troop maneuvers simulate, as closely as possible, the conditions most likely to be encountered under live combat situations (e.g., hardware, weapons fire, terrain, weather, vegetation, and smoke concentrations). Within the framework of the training operations, the Army has a regulatory responsibility to ensure that the use of smokes and obscurants does not adversely affect the health of local residents, or the environment, both on and near the training sites. The environments of these training centers range from high deserts to semitropical forests, thus complicating this responsibility.

The Health Effects Research Division of the U.S. Army Biomedical Research and Development Laboratory (USABRD) has been assigned the responsibility of determining the potential environmental effects associated with the use of smokes and obscurants in training and testing. As part of USABRD's planned program in response to this concern, the present study was designed by Pacific Northwest Laboratory (PNL) to evaluate the transport, chemical transformation, and terrestrial ecological effects of several smokes currently used in Army training sites throughout the United States. The present study expands previous field studies in two major respects. First, smoke and obscurant testing is conducted within a special recirculating wind tunnel that ensures containment of the smoke and allows simulation of a variety of environmental conditions (i.e., varying wind speeds, relative humidities, temperatures and lighting conditions) under dynamic exposure conditions. Second, the complex chemical nature of obscurant smokes requires that chemical transformations be correlated with environmental effects in a defined manner.

Within the framework of the experimental design for the present studies, the primary objective was to assess the influence of two primary environmental variables: or, the relative humidity (20, 60, 90%, and simulated rain) and the wind speed (2 to 10 mph or 0.90 and 4.5 m/s) on the ecological effects induced by smokes. The second overall objective was to determine whether mixed-smoke exposure scenarios employing white phosphorus, hexachloroethane, and fog oil obscurants in battlefield sequence result in environmental impacts similar to, or greater than, those observed for individual component obscurants. The sequence of obscurants used in this study was selected commensurate with U.S. Department of Defense (DOD) Battlefield Tactics Manuals DAPAM 525-3 and DAPAM FC 350-1.

The health and environmental effects of Army smokes and obscurants have been studied intensively over the past 30 years; these research efforts have recently been compiled and reviewed by Shinn et al. (1985) and Cichowicz (1983). In general, research

into the effects of obscurant smokes has concentrated on animal and aquatic toxicity, with relatively little effort being expended in understanding soil/plant or ecological effects. The majority of these previous efforts used direct artificial dosing of organisms or aqueous amendments of suspected toxicants. Although these methods may be appropriate and necessary in many instances, they may not be appropriate in developing an understanding of the potential impact of the recurrent use of obscurant smokes at heavily used training sites. This is mainly because no established correlations exist between airborne smoke concentrations, depositions on soils and plants (duration and physical parameters affecting deposition), and the ultimate effects, environmental deterioration.

Previous studies associated with this project have investigated the environmental fate and effects of the individual obscurant smokes. Red phosphorus rubber and white phosphorus smokes (Van Voris et al. 1987), fog oil (Cataldo et al. 1989a), and hexachloroethane (Cataldo et al. 1989b). These wind tunnel experiments established the physical and chemical characteristics of the individual smoke aerosols, evaluated deposition velocities for smoke aerosols to both foliar surfaces and soils, and established the dose response relationships and extent of impacts for terrestrial plants, soil microbes/processes, and soil invertebrates. Results of these studies are summarized in the subsections below.

1.1 FATE AND EFFECTS OF PHOSPHORUS SMOKES (Van Voris et al. 1987)

1.1.1 Physical and Chemical Characteristics of Phosphorus Smoke.

The particle size mass median aerodynamic diameter (MMAD) and distribution geometric standard deviation (GSD), of steady-state aerosols were determined to be $1.6 \mu\text{m} \pm 1.6$ at relative humidities (RH) from 25 to 60%; particle size increased to $1.9 \mu\text{m}$, as RH increased to 90%. White phosphorus aerosols exhibited similar increases in particle size with increasing RH, ranging from 1.5 to $1.75 \mu\text{m}$. These changes resulted from hydration of the aerosol particles. Aerosol particle size was influenced by its age or residence time in the tunnel. The MMAD of fresh RP aerosols (5 to 10 min) was slightly smaller than aged (> 50 min) aerosols; for WP, the size of fresh versus aged aerosols was 1.1 to $1.3 \mu\text{m}$. Thus, the aged aerosols employed in these and subsequent wind tunnel tests were aged and simulated those at approximately 1500 m from a field generator. All phosphorus exposures were conducted at 400 to 500 mg P/m³ air.

The chemistry of RP and WP aerosols was time and humidity dependent. The content of phosphate in phosphorus smokes increased from 25 to 100% with aging in moist air. The polyphosphates (P_n , $n = 2$ to >20), which compose 75% of the initial aerosol mass, are converted to 1P (phosphate) in the presence of water. The fractions 5-13P and 2-4P make

up the remainder of the non-phosphate P for both the RP and WP aerosols. During WP studies, the concentrations of phosphine within the wind tunnel ranged from below detection limits 43 to 70 $\mu\text{g}/\text{m}^3$, with the higher values found only under higher RH conditions. Similarly, elemental WP levels ranged from 0.007 to 0.015% of total P deposited to surfaces and decreased to 0.0002% in 4-h tests. Contact with moist surfaces reduced these concentrations to below detectable levels.

Deposition velocities (V_d) for RP and WP aerosols were calculated at 0.013 cm/s for all plant surfaces. These increased somewhat with RH because of increased MMAD of aerosols. Wind speed had a pronounced effect of V_d , with values increasing from 0.01 at 2 mph to >0.8 cm/s at 10 mph.

1.1.2 Impact of Phosphorus Smokes on Soil Chemistry

Analysis of leachates from RP- and WP-exposed soils indicated that the hydrolysis rate for the higher polyphosphates was accelerated. However, phosphorus aerosol deposition resulted in increased acid to soils, which may exceed the buffering capacity at the surface of soils. Increased Al solubility was noted, and although not related to acidity or phosphate contained in deposited aerosols, was believed to be based on the presence of condensed phosphates.

1.1.3 Foliar Contact Toxicity: Direct Effects

Contact toxicity was investigated and quantified based on the actual received dose, i.e., mass loading, as the absolute measure of chemical insult. The effects of RP and WP were assessed under a number of simulated conditions. These included mass loading (RFT series), relative humidity (RHT series), wind speed (WST), the influence of plants to compensate to cumulative dose episodes (CDT series), post-exposure leaching, and dosing during simulated rainout conditions. Wind speed was shown to have the most pronounced effect on mass loading, and therefore, phytotoxicity. Primarily, it was the result of a logarithmic increase in mass loading as wind speed increased from 2 to 10 mph.

A number of general observations concerning the toxicity of phosphorus smokes to native vegetation in the contact toxicity mode were made. First the dose/response relationships for RP and WP smokes were generally similar for the five plant species studied. Second, application of a post-exposure simulated rainfall tended to ameliorate phosphorus effects by removing a substantial fraction of the dose. Third, relative humidity had a variable influence on toxicity; increased RH increased toxicity in ponderosa pine and sagebrush, but had little consistent effect on sagebrush, blando brome, or bushbean. Fourth, a pronounced

increase was apparent in mass loading, and therefore, toxicity response at wind speeds in excess of 4 to 6 mph. Fifth, plants receiving a series of nine consecutive dosings over a 3-week period appeared to compensate for the cumulative dose, resulting in minimal phytotoxic response, compared with single large dose events. Last, with the exception of the bush bean, each plant species that was severely impacted to the point of defoliation, exhibited secondary bud activity and recovered within 30 to 45 days post-exposure. This would indicate that toxicity is generally localized to the impacted foliage, and that periodic severe effects are transient and can be tolerated by the plant.

1.1.4 Residual and Indirect Soil/Plant Effects

Although the adverse environmental impacts resulting from contact toxicity from RP and WP smokes appear to be transient in nature, associated studies suggest that the recurrent use of phosphorus smokes may have a long-term impact on plant performance at heavily used training sites. These include: 1) the residual effects studies where foliarly exposed grasses are cut back and allowed to regrow; and 2) the indirect effects studies where soils are contaminated with phosphorus smokes and subsequently seeded with grass. In the residual effects studies performed in the CDT and WST series, second harvest biomass results indicated that some component of the smoke residuals deposited to the foliage was absorbed and transported to the root, where during the second regrowth, significant biomass reductions resulted. The effect was much more pronounced for RP compared with WP treatments. A similar effect was noted in the indirect effects studies where soils were contaminated before planting. This aspect of the environmental impact of phosphorus smokes can, if not transient in nature, result in reduced environmental vigor of selected plant species.

1.1.5 Impact of Phosphorus Smokes on Soil Microflora

Phosphorus smokes were shown to significantly affect soil microbiological activities. Reductions in ammonification and nitrification, and phosphatase and dehydrogenase activities were observed for all treatments. Effects were most pronounced in the upper few millimeters of the soil, which received deposited phosphorus.

1.2 FATE AND EFFECTS OF FOG OIL SMOKES (Cataldo et al. 1989a)

1.2.1 Physical and Chemical Characteristics of Fog Oil Smoke

Fog oil aerosols were generated by vaporization and condensation of SGF-2 fog oil. The aerosol was aged under simulated natural conditions and used to expose plant, soil, and other test systems. Aerosol mass concentrations ranged from less than 100 to 1000 mg/m³, depending on the test series or exposure parameter evaluated. Particle sizes of airborne FO ranged from 1.6 to 3.1 μm, and the composition of the aerosol appeared not to be affected by relative humidity over a range of 20 to 91%.

Average deposition velocities to plants ranged from 0.016 to 0.037 cm/s. Mass loading values and calculated deposition velocities to plant foliage showed significant variation between species. Plants with open canopies, such as pines and sagebrush, were a factor of 1.5 to 2 higher than plants with closed canopies, such as bush bean and tall fescue. The particle size and aerodynamic behavior of FO smoke were not affected by relative humidity, and therefore, appeared to have little influence on deposition velocity and subsequent mass loading to plant or soil surfaces. Wind speed had a pronounced effect on deposition to surfaces, with deposition velocity to foliar surfaces increasing dramatically from 0.02 cm/s at 2 mph, to 200 to 1000 cm/s at 10 mph .

Depuration of FO aerosol residues collected by deposition to glass fiber filter substrate under laboratory conditions was approximately 6% of the total amount deposited after 10 days and 14% after 65 days. In contrast, the depuration rate from environmental surfaces was much greater. Depuration losses from ponderosa pine were approximately 80% after 4 days, with a half time of 1.7 days. This rapid loss results from volatilization from the relatively large foliar surface area. Depuration from the Maxey Flats soil was biphasic, exhibiting a rapid loss with a half time of 20 days, followed by a reduced volatilization with a half time of 500 days. Depuration of FO from the Burbank soil was monophasic with a half time of 58 days. Differences in behavior between soils is believed to result from both higher surface sorption in the Maxey Flats soil, which allowed for an initial increased volatilization and a higher downward leaching in the more porous Burbank sand, which reduced the initial rate of volatilization.

1.2.2 Foliar Contact Toxicity: Direct Effects

Based on a deposited dose of 100 to 500 μg FO/cm², equivalent to 2- to 8-h exposure to smokes at 900 mg/m³ air, toxicity responses were judged moderate. The visualized effects were chlorosis, necrotic spotting of foliage, and leaf or needle burn. Relative humidity had no

dramatic effect on the quality or intensity of damage, other than that expected based on deposited dose. Repetitive dosing at 2- to 3-day intervals resulted in substantially less damage than indicated by the total delivered dose. This amelioration in effects apparently resulted from the rapid loss by volatilization of FO from foliar surfaces. Post-exposure simulated rainfall had little or no impact on the extent of FO damage. The comparatively low phytotoxicity of FO resulted from the low concentration of aromatic hydrocarbons contained in the oil. The aliphatic hydrocarbons, which are the major constituents of FO, were less phytotoxic than aromatic hydrocarbons. However, the aliphatic hydrocarbons can affect membrane/cell permeability and likely accounted for the observed damage.

1.2.3 Residual and Indirect Soil/Plant Effects

Residual effects, namely those that result from foliar absorption of smoke constituents transferred to below ground plant tissues, were apparent in several of the test series. Although these appeared to be persistent in short-term studies (two croppings of tall fescue), the causative hydrocarbons were normally biodegradable, and the effects were attenuated in time. Indirect effects, those that impact the plant following soil deposition of smoke constituents, were somewhat dependent on soil type. In general, grass grown on Burbank soil was less affected than that grown on Maxey Flats soil. This difference may well have resulted from the relative retention of FO on these two soil types. In no case was seed germination affected.

1.2.4 Impact of Fog Oil Smokes on Soil Microflora

Fog oil deposited to soil had little deleterious effect on soil microbial activity. On the contrary, it enhanced the microbial activities in many of the parameters assayed. Cumulative dose of FO exposure had no effect on soil respiration, and slightly increased the activity of *nitrobacter* populations in Palouse soil, while no change was observed in Burbank soil. In addition, the cumulative dose of FO greatly increased soil dehydrogenase activity particularly in Palouse soil. Although exposure to FO at 20 to 91% RH or at 10 mph wind speed showed a slightly inhibitory influence in dehydrogenase activity and soil nitrifying bacteria in a few instances, respiration was not affected by these exposures. This was in contrast to exposure to red phosphorous/butyl rubber smoke, which had a strong inhibitory influence on a number of key soil microbial and enzymatic activities (Van Vorls et al. 1987).

1.2.5 Soil Invertebrate Effects

Earthworm bioassays indicated no adverse effects of FO with exposures up to 800 $\mu\text{g}/\text{cm}^2$ soil. *In vitro* studies, where FO was uniformly amended to soil, showed earthworm survival to be 100% until a soil concentration of $\sim 3600 \mu\text{g}/\text{cm}^2$ (285 μg fog oil/g) was reached.

1.3 FATE AND EFFECTS OF HEXACHLOROETHANE SMOKES (Cataldo et al. 1989b)

1.3.1 Physical and Chemical Characteristics of HC Smoke

Air concentrations of HC smoke were maintained at approximately $500 \text{ mg}/\text{m}^3$ for all test series except for the cumulative dose tests, which were established at 150 and $700 \text{ mg}/\text{m}^3$ for the low and high dose scenarios, respectively. The MMAD (\pm GSD) for the aerosols averaged $1.7 \mu\text{m}$ (1.5) for all test series, with relative humidity having a direct effect on MMAD; MMAD values increased from 1.7 to $2.1 \mu\text{m}$ as relative humidity increased from 20 to 85%.

The HC smokes contained $>50\%$ extractable ZnCl_2 on a mass basis, with chlorocarbon compounds composing slightly $>1\%$ of the mass; the remainder of the mass was associated with insoluble carbonaceous ash. The results indicated that most, if not all, of the biotic effects were from either Zn or possible changes in pH. The chlorocarbon compounds, including CCl_4 , C_2Cl_4 , C_2Cl_6 and C_8Cl_6 , were found to be in concentrations of 5 to $7 \text{ mg}/\text{m}^3$. The environmental half-life of organochlorines associated with plant foliage ranged from 1 to 80 days, and was dependent both on compound type and relative humidity. Half-lives for soils were higher than for plant surfaces, and ranged from 5 to 70 days.

Results of HC deposition studies for soils and deposition plates indicated that acidification of the soils to levels comparable to those of the wet deposition plates generally caused similar solubilization characteristics as those found on exposed soils. As expected, delaying water contact had no observed effect; this was in contrast to the significant effect on P speciation resulting from phosphorous aerosols. Depression of nitrate in some exposed soils likely reflects the initial suppression of microbial activity.

1.3.2 Foliar Contact Toxicity: Direct Effects

As observed with previous smoke studies (Van Voris et al. 1987; Cataldo et al. 1989a), mass loading of the tissues increased with both exposure time and increasing wind speed. There appeared to be no significant effect of increased relative humidity on foliar mass

loading, and post-exposure leaching significantly reduced the original mass loading levels with a concomitant reduction in phytotoxic effects. The pines and sagebrush exhibited slightly higher mass loading rates, and this may have been related to foliar morphology. The overall phytotoxicity of the HC smokes to vegetation appeared to be linked to the degree of Zn deposition (accumulation) to the tissues during the course of the exposures. Under all exposure conditions, the bush bean proved to be the most sensitive in exhibiting both visual and physiological (photosynthesis/respiration) phytotoxic responses, with the ponderosa pine appearing least sensitive of those species tested.

1.3.3 Residual and Indirect Soil/Plant Effects

Dry matter accumulation for the grasses was reduced immediately following exposure; however, regrowth rates for subsequent harvests of foliarly exposed plants did not significantly differ from those of the controls. Secondary effects on dry matter accumulation by grasses grown in exposed soils were not evident following any of the exposures. Although a significantly elevated tissue concentration of Zn was present in these plants, there were no apparent interactions of Zn or Al on the mineral nutrition of exposed plants.

1.3.4 Impact of HC Smokes on Soil Microflora

Soil subjected to HC exposure showed inhibition of soil respiration, dehydrogenase and phosphatase activities, and a decline in populations of nitrifying bacteria. The inhibition depended largely on soil types and HC aerosol mass concentration. Exposures for 1 or 2 h resulted in no significant effect on soil dehydrogenase activity, but prolonged exposure for up to 4 h inhibited soil respiration and enzymatic activities. Inhibition of nitrifying bacteria was less pronounced in Palouse soil than in Burbank soil, and *Nitrosomonas* spp. was less sensitive to HC smoke exposure than *Nitrobacter* spp. Reduced soil respiration and dehydrogenase activity were also observed in soils subject to HC aerosol under various relative humidities. The only exception was Palouse soil amended with glucose, which showed enhanced dehydrogenase activity at 1 to 2-weeks post-exposure time. The results indicated that *Nitrosomonas* spp. was less sensitive to HC smoke exposure than *Nitrobacter* spp. When soils were repeatedly exposed to HC aerosol smoke, soil respiration was inhibited along with dramatically reduced enzymatic activities. Soil dehydrogenase decreased to 1 to 15% of unexposed control in both soil types tested. Phosphatase declined to 12 to 51% of unexposed control in Burbank soil while exerted some effect only after 4 weeks. The cumulative dose tests also showed that *Nitrosomonas* spp. was less sensitive to exposure than *Nitrobacter* spp. in Palouse soil; however, both groups of nitrifiers were reduced to below detection limit in Burbank soil. Results indicated that HC aerosol smoke is likely to have a negative impact on soil microbial activities and populations.

Overall, HC smokes are less toxic to terrestrial biota than were the phosphorus smokes (Van Voris et al. 1987), but HC smokes are more toxic than observed for FO smokes (Cataldo et al. 1989a). The biotic effects noted appear to be based on increased Zn loads to soils or vegetation, or may be based on transient changes in soil pH resulting from the acidity of HC aerosols.

1.3.5 Soil Invertebrate Effects

Earthworm survival was not impacted by HC aerosols deposited to soils at rates of 8 $\mu\text{g Zn/cm}^2$ or 32 $\mu\text{g HC/cm}^2$.

1.4 MIXED-SMOKE SCENARIOS

This report presents detailed results associated with the formation, transport, atmospheric transformation, deposition, and terrestrial ecological effects of a series of mixed-smoke exposures. The studies described are similar in nature to those performed with red phosphorus rubber and white phosphorus smokes (Van Voris et al. 1987), fog oil obscurants (Cataldo et al. 1989a) and HC smokes (Cataldo et al. 1989b). The purpose of these investigations are to establish whether the sequential application of mixed smokes to simulated training scenarios has adverse environmental effects different than individual obscurant smokes.

The effects of mixed smokes on the following three primary ecosystem components were evaluated:

- Natural terrestrial vegetation characteristic of U.S. Army training sites in the United States
- Physical and chemical properties of soils at those sites
- Soil microbiological and soil invertebrate communities.

2.0 MATERIALS AND METHODS

Studies employing mixed smokes, including HC, WP, and FO, were conducted at the Aerosol Wind Tunnel Research Facility at Pacific Northwest Laboratory. This facility houses an environmental wind tunnel suitable for testing obscurant smoke under a variety of environmental conditions. The environmental wind tunnel, shown in Figure 2.1, and supporting laboratories are used for research involving generation, transport, deposition, and characterization of aerosols and gases in complex atmospheric environments. A more detailed description of the wind tunnel, and specific methods related to the individual smokes, can be found in Van Voris et al. (1987), Cataldo et al. (1989a), and Cataldo et al. (1989b).

2.1 AEROSOL WIND TUNNEL RESEARCH FACILITY

The PNL Aerosol Wind Tunnel Research Facility provides a combination of special capabilities for laboratory simulation of natural environments. Tests are performed of the transport, deposition, resuspension, and chemical fate of airborne particles and gases. Advantages of laboratory tests over actual field tests include controlled and reproducible (on-demand) test conditions. It is also of critical importance that such studies be performed in dynamic conditions provided by wind tunnels rather than in static or stirred exposure chambers. This is because of several conditions that are influenced by a dynamic environment: 1) contaminant aging in natural environments may include chemical and physical transformations that may be influenced by sunlight, humidity, temperature, or other parameters; 2) deposition of airborne particles, whether by diffusive or inertial forces, to various test subjects such as plants, soils, and water surfaces, is strongly influenced by wind speed and the flow field generated within plant canopies or the boundary layers of wind over leaves and other surfaces; and 3) the chemical fate of particles deposited to surfaces, or the rate of transfer of contaminants from the surface to the interior of plants and soils may be altered by the aging of surface deposits under the influences of temperature, humidity, and wind speed. Under static conditions (chambers with no uniform air flow, either with or without temperature and humidity control) transport, transformation, and effects of airborne materials will likely not be similar to those occurring in actual field environments. The dynamic conditions created in an environmental wind tunnel provide realistic simulation of natural environments for transport, transformation, and fate and effects experiments.

The laboratory of the research facility houses a sealed, recirculating (or closed-loop) wind tunnel, controlled-environment plant growth chambers, instruments for aerosol characterization, and a computer system, and is supported by a variety of analytical chemistry laboratories. Designed for total containment of airborne toxic, hazardous, and radioactive materials, the facility offers a unique capability to conduct aerosol research on such materials

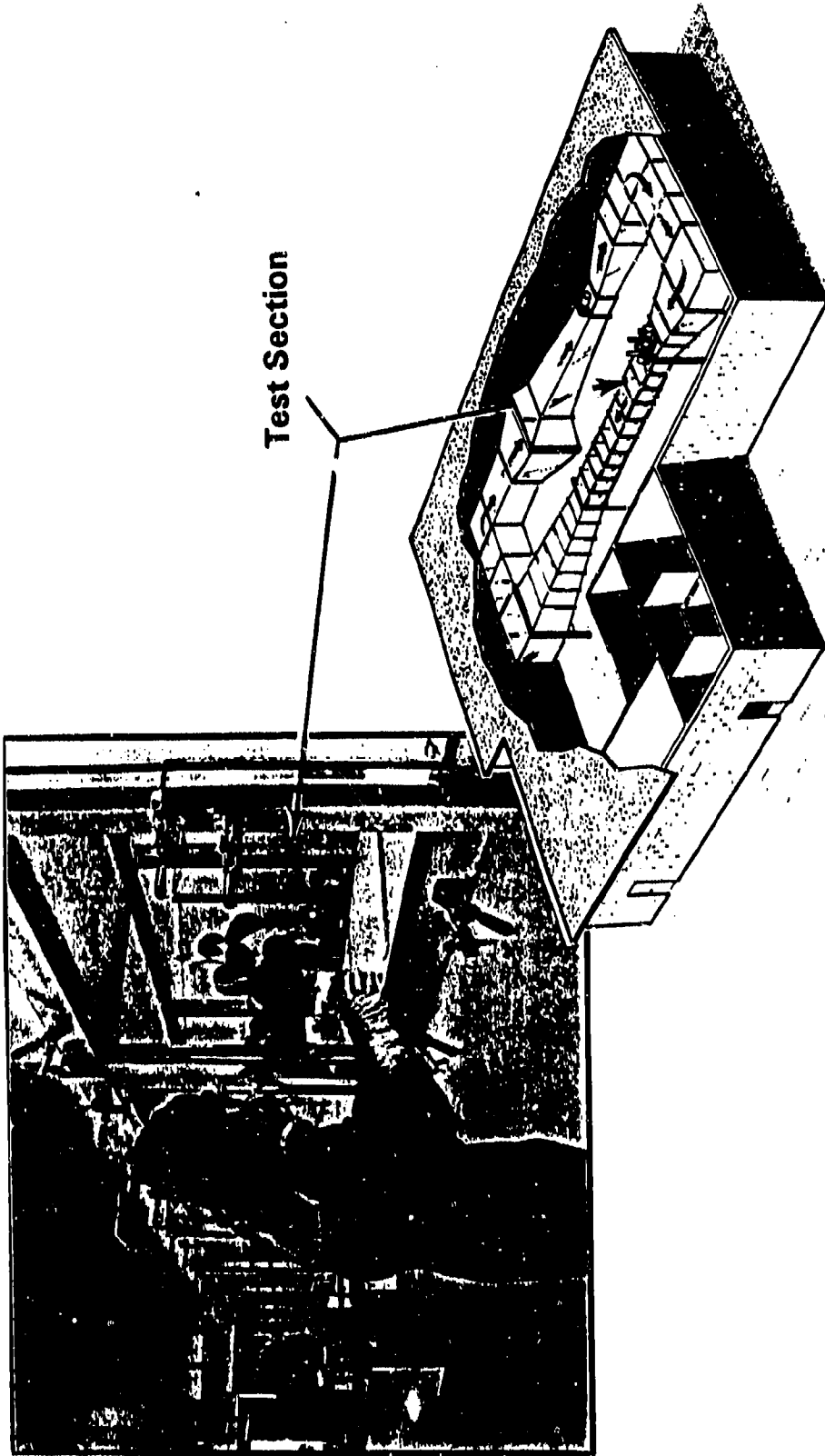

Test Section

FIGURE 2.1. PACIFIC NORTHWEST LABORATORY AEROSOL WIND TUNNEL

in a dynamic environment simulating natural field conditions. Computerized control of, and data acquisition for the wind tunnel exposure environment includes temperature, humidity, illumination, wind speed, gas species concentration, and airborne contaminant composition and dispersion.

The laboratory of the facility is supplied with filtered ambient air for ventilation; an independent exhaust system then draws this single-pass air through double banks of HEPA "absolute" filters before release. The wind tunnel is operated at a negative air pressure during tests to contain contaminants.

2.1.1 Environmental Wind Tunnel

The environmental wind tunnel of the PNL Aerosol Wind Tunnel Research Facility is used to study the transport, deposition, and chemical fate of airborne contaminants on physical and biological systems. The wind tunnel is ideally suited for environmental studies because of its large, 68 m³ (2400 ft³) volume, and because it is insulated and supplied with environmental control systems. Temperature is controlled by an air conditioning system; relative humidity is controlled by computerized injection of water vapor via an ultrasonic atomizer; and gas concentrations may be controlled by computerized monitoring and injection.

The wind tunnel is constructed of stainless steel and transparent Lexan® for resistance to chemical corrosives. A 300 psi washdown system is used to clean and decontaminate the wind tunnel following tests. Constructed as a closed-loop system as shown in Figure 2.2, the wind tunnel may also be operated in single-pass mode for many research applications by installing a 48-ft² bank of HEPA filters in the return section, just upwind of the 30 hp belt-driven fan. Because of the low pressure drop across the large area of the filter bank, the maximum attainable speed in the primary test section is 31 m/s (70 mph) either with or without the HEPA filters. Secondary test sections provide alternative testing locations to the 0.6-m-square primary test section; two 1.5-m-square, and one 2-m-square test sections may be used for large test subjects.

2.1.2 Wind Tunnel Test Section

The primary test section of the wind tunnel is 6.1 m long and 0.6 m wide and tall with transparent Lexan® walls, Cleveland, Ohio, and ceiling (see Figure 2.1). Mean wind speed is controllable between 0.2 and 31 m/s (0.5 and 70 mph). Uniform air flow is provided by reducing boundary layer at the inlet to the test section using a specially-shaped effuser section and turning vanes in all corners of the wind tunnel. Velocity is uniform over the center 85% of the test section cross section, and velocity gradients are typically less than 4%. Because

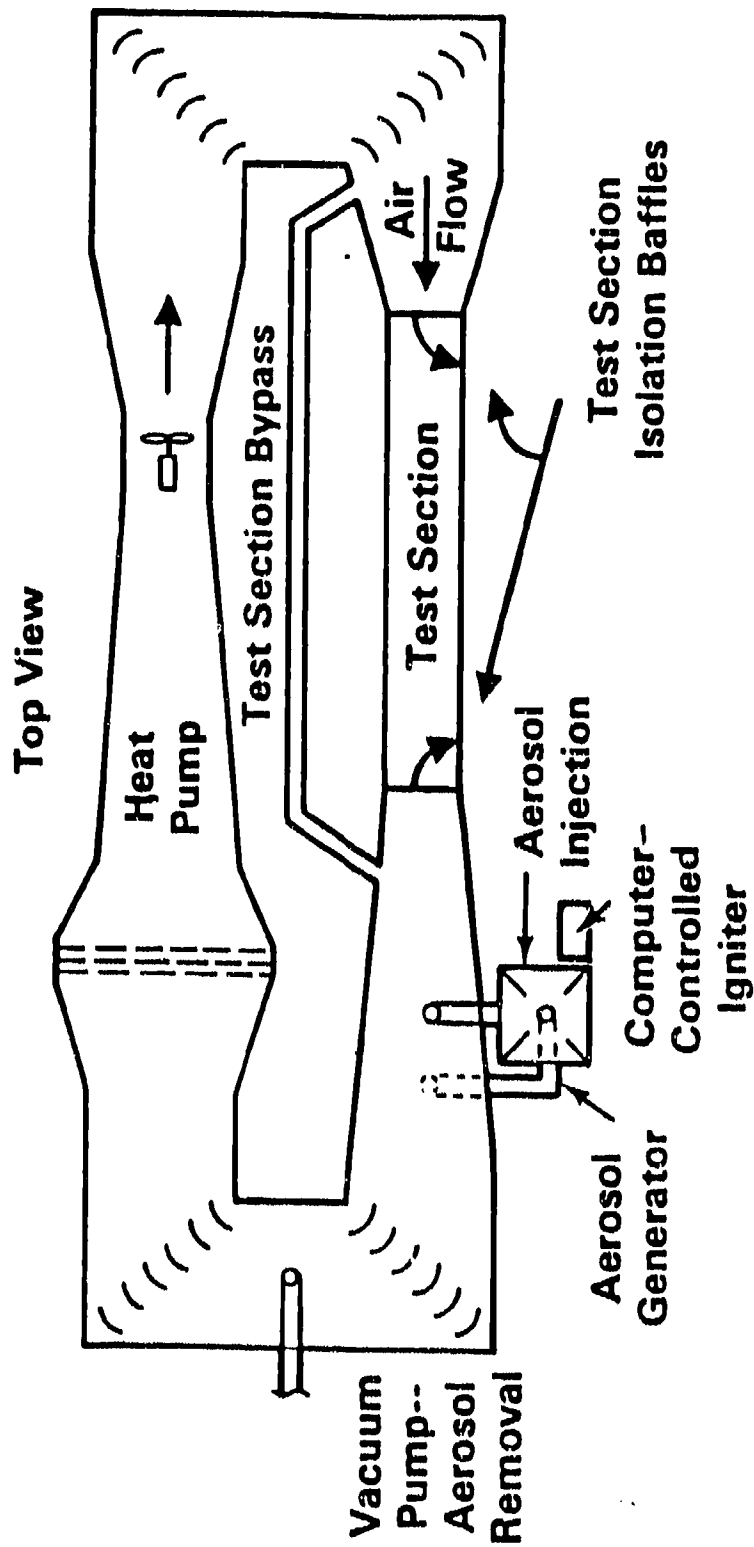

FIGURE 2.2. CLOSED-LOOP WIND TUNNEL, AEROSOL GENERATION AND INJECTION, AND PRIMARY TEST SECTION

aerosol generation is usually performed downwind of the test section, mixing is complete and uniform contaminant concentrations are provided to test subjects. Illumination is provided to maintain plant respiration processes; four adjustable 400 W metal halide lamps are mounted above the test section, and UV lamps are also available. Plant pots and other portions of test subjects that do not require exposure are placed below the surface of the test section floor within a false floor.

To facilitate tests, isolation baffles are installed on the inlet and outlet planes of the test section. Upon completion of a test, these isolators are rotated upward to seal the test section from the rest of the wind tunnel. The air within the test section is then quickly cleared by purging it with clean, filtered laboratory air, thus providing a controlled end-of-test or providing an opportunity to access the test section and exchange test subjects for a second or continued exposure test. During the time the test section is isolated, a bypass duct is operated, thus maintaining a dynamic atmosphere in the remainder of the wind tunnel. Because the primary test section contains only 5% of the total wind tunnel volume, tests may be performed in a series by reopening the test section and continuing the testing immediately, without the need to recreate the test atmosphere.

2.1.3 Aerosol Instrumentation

An inventory of instrumentation is available to monitor the test environment and aerosol concentration, particle size distribution and shape, and chemical composition. A computer control and data acquisition system is used to program experiments and document monitoring instrument data and status. The system provides flexibility to operate during a variety of experiments and provides alarms to alert the operator if specific conditions or aerosol characteristics are not maintained within preset tolerances.

In addition to aerosol measuring devices, aerosol generators are available for the generation of most types of suspended particulate contaminants. In addition to monitoring the suspended contaminant, other aspects of the exposure environment are monitored. Wind speed is measured using hot film anemometry or by employing differential pressure transducers connected to pitot-static probes. Temperature and relative humidity are measured in the wind tunnel and at other locations using connected thermocouples and optical dew point sensor systems. The concentrations of specific gas or vapor species are monitored by a collection of analyzers and on-line gas chromatograph.

Aerosol mass concentrations $<0.01 \text{ mg/m}^3$ to $>10 \text{ g/m}^3$ are measured using isokinetic filter samples, laser transmissometers, and single- and multiple-particle light scattering devices. Physical samples are analyzed gravimetrically, or by chemistry, fluoroscopy, or

optical or scanning electronic microscopy (SEM). Particle size distributions of airborne contaminants are measured for particles with diameters ranging from 0.003 to 450 μm using a variety of instruments employing inertial, diffusive, optical, and electrical mobility classifying procedures. One analyzer sizes and counts particles remotely using a pair of He-Ne laser beams. That device provides the advantages of analyzing particles without the use of a physical probe that may influence air flow and particle deposition patterns, rapid (real-time) analysis of airborne material, and reduced need to remove toxic and hazardous materials from the wind tunnel for analysis.

2.1.4 Analytical Chemistry

In addition to the size and concentration of airborne particulate contaminants within the wind tunnel, it is important to characterize the chemical form of the particles. While many aerosols such as some ash, dust, and metal aerosols are relatively chemically stable, many aerosols are transformed chemically between generation or suspension and deposition. Because of this, aerosol samples and samples from deposition coupons and plant, soil, water, and other test surfaces are analyzed by chemical methods. Analytical methods employed include: 1) high pressure liquid chromatography (HPLC), 2) gas chromatography (GC), 3) mass spectrometry (MS), 4) GC/MS, 5) anion chromatography (AA), and 6) inductive coupled argon plasma spectrometry (ICAP).

2.2 EXPOSURE CONDITIONS

The exposure environment within the wind tunnel was controlled. Both wind speed and relative humidity were varied as test parameters. Concentration of mixed-smoke aerosols and time of exposures were also controlled to provide known test conditions. Temperature was monitored, but not varied as a test parameter for mixed-smokes tests. The environmental and aerosol conditions occurring during tests were monitored and recorded using the computer system and other devices such as isokinetic samplers, cascade impactors, and particle impingers. After setting the test environment prior to each test, aerosols were generated in sequence using miniature hexachloroethene (HC) smoke pots (Cataldo et al. 1989a), a vaporization/condensation generator (Cataldo et al. 1989a) for fog oil (FO), and masses of white phosphorus (WP) in ceramic cups (Van Voris et al. 1987). Aerosols were introduced into the wind tunnel downwind of the test section. Generation of HC aerosols was performed at regular intervals during the first third of most tests, FO aerosol continuously during the middle third, and WP at regular intervals during the final third. Selected tests were performed using only two of the three smokes in combination; however, the smoke-ordered sequence was always followed to simulate established field scenarios.

2.2.1 Exposure Environment

Environmental parameters in the wind tunnel were controlled. Air temperature was constant for individual tests, and was between 21 to 24°C during most tests. The relative humidity of the wind tunnel atmosphere was controlled and ranged from 47 to 55%; water vapor was added to the system to maintain constant humidities. Tests were performed at wind speeds of 0.9, 1.8, 2.7, and 4.6 m/s (2 to 10 mph).

The humidity of the wind tunnel atmosphere was typically measured during each test using a General Eastern Model 1500 Hygrocomputer, Watertown, Massachusetts. Samples were drawn from the wind tunnel continuously during each test either through a teflon-substrate filter suspended in the wind tunnel downwind of the test section, or via a sample drawn from the wind tunnel through another teflon filter. The filter was protected from particulate deposits by a plastic sheath on the upwind side. The dewpoint sensor was cleaned periodically. The hygrocomputer was also used to measure wind tunnel temperature, and was calibrated by comparison with a precision controlled-draft sling psychrometer.

The mean, or average wind speed approaching the test subjects in the wind tunnel test section was measured using either a Thermal Systems Incorporated (TSI), St. Paul, Minnesota, hot-film probe Model No. 1368 connected to a TSI Model No. 1054A anemometer, or, during the Cumulative Dose tests, a pitot-static probe connected to a MKS Inc., Andover, Main, Baratron differential pressure transducer. The hot-film anemometer was calibrated by comparison with a pitot-static probe connected to a Dwyer Model No. 1430 micromanometer, Michigan City, Indiana. The MKS transducer was also compared to the micromanometer and found to be suitably accurate.

2.2.2 Mixed-Smoke Test Series

Seven series of tests were performed using mixed-smokes obscurants. These included trial tests, combined range-finding/wind speed tests, four types of cumulative dose test series, and a set of two tests of FO only obscurant. Table 2.1 lists test identification numbers, the sequence of smoke generation, date of performance, and a description of each test series. Initial trial tests were performed to test aerosol generation and characterization methods and to determine specific procedures for attaining target aerosol concentrations. The range-finding and wind speed test series were combined as increased deposition at the greater wind speeds provided increased mass loading required for range-finding effects studies. Because FO concentrations were reduced during tests MS-7 and MS-8 due to a failure of the oil pump, a second cumulative dose series was performed with all three smokes. Following repairs to the fog oil generator, a trial test of fog oil only was performed (MSFOT1). The second fog oil test

(MS-13) was performed to provide additional aerosol and deposition data as the presence of HC and WP interfered with chemical analyses. Cumulative dose tests series 3 and 4 were performed in an effort to isolate effects of various components of mixed smokes and allow comparison with previous tests employing single smokes.

TABLE 2.1. DESCRIPTION OF MIXED-SMOKE TEST SERIES

Exposure Test ID	Date	Smoke Employed	Test Description
MS-1 & 2	6/87 - 7/87	HC/FO/WP	Trial aerosol tests. No plants
MS-3, 4, 5, & 6	7/87	HC/FO/WP	Range-finding/wind speed
MS-7 & 8	1/88	HC/FO/WP	1st cumulative dose series
MS-FOT1	1/88	FO	Trial Fog Oil Test. No plants
MS-9 & 10	2/88	HC/FO/WP	2nd cumulative dose series
MS-13(FO)	2/88	FO	FO deposition test (with plants)
MS-14 & 15	5/88	FO/WP	3rd cumulative dose series
MS-16 & 17	5/88	HC/FO	4th cumulative dose series

2.2.3 Test Procedures and Measured Conditions

The dynamic exposure environment within the wind tunnel was selected for these tests because of the need to accurately reproduce particulate deposition characteristics, which are strongly influenced by wind speed and air flow patterns in plant canopies. To prevent unrealistic aging of the mixed-smoke aerosols in the wind tunnel, a flow of carrier air was provided to the aerosol generation chamber to transport the aerosol into the wind tunnel, and an equivalent flow was drawn out of the wind tunnel. This transfer flow rate was approximately 20 cfm and resulted in a net loss of aerosol from the wind tunnel system of approximately 1% per minute. Aerosol losses by deposition to the test subjects and the surfaces of the wind tunnel accounted for an additional ~1% per minute. The mixed-smoke aerosol was therefore a mixture of freshly generated and aged particles; this experimental laboratory approach was followed to provide simulation of actual field conditions. Based on the residence time within the wind tunnel, the average age of the mixed-smoke aerosol in the wind tunnel was estimated

to be about 2 min, or similar to that of a field-generated aerosol that had drifted approximately 1.5 km downwind under the influence of a slow 0.9 m/s (2 mph) wind.

The duration of the exposure interval for each wind tunnel test was based on visual observation of the smoke density. The test section was bypassed, isolated from the wind tunnel, prior to each Range-Finding/WindSpeed test to allow the concentration of HC aerosol to build up. At that time, the exposure was begun by allowing HC smoke to pass through the test section and closing the bypass loop. The test section was not isolated during the start of the Cumulative Dose tests, and test timing began approximately 3 min following generation of the first HC pot. Aerosol generation continued until the test was finished, at which time the test section was again isolated and flushed with fresh air. The test section was also isolated from the wind tunnel during selected Cumulative Dose tests to allow exchange of test subjects and deposition coupons. Because approximately 5 min were required to flush the visible smoke from the test section at the end of each test, the end of the exposure test was assigned to that time when the test section purge was one-half complete, which was typically 2 or 3 min following initiation of test section purging.

Test durations were about 3.5, 5, and 7 h. Actual test durations were slightly longer or shorter than target durations because of requirements of the generation sequence or mid-test sample transfer periods. In addition to tests for instrument calibration or tests of the HC aerosol generator, two series of tests were performed: range finding/wind speed, and cumulative dose.

The range finding/wind speed tests included 3.5-h exposures. The tests were performed at 0.9, 1.8, 2.7, and 4.6 m/s (~2 to ~10 mph). Four series of cumulative dose tests were performed using various combinations of mixed smokes. Test durations were 5 (two aerosols) or 7 (three aerosols) h in duration. Wind speed was about 1.78 m/s (4 mph), and temperature and relative humidity were at ambient levels. One FO-only test was performed to provide deposition rate information. Table 2.2 shows a summary of average conditions existing within the wind tunnel during each mixed smoke test. Average test conditions are shown at the bottom of the table for both Range-Finding/Wind Speed ($21.7 \pm 0.7^\circ\text{C}$, $52.5 \pm 2.6\%$, 0.9 to 4.6 m/s), and the Cumulative Dose ($22.4 \pm 1.1^\circ\text{C}$, $51.3 \pm 1.9\%$, 1.78 ± 0.04 m/s) test series. Tables 2.3 and 2.4 show average and fluctuating values of temperature, relative humidity, and wind speed during the tests. The number of samples obtained during a particular sample period or test is indicated in the tables by No. (#).

Wind speed data, including natural fluctuations in the wind tunnel air flow and measurement uncertainties are presented in detail for the mixed-smokes tests in Table 2.4. The greatest deviation of measured wind speed from average was seen to be 6% at 0.9 m/s, 10% at 1.8 m/s, 3% at 2.7 m/s, and 1% at 4.6 m/s.

TABLE 2.2. ENVIRONMENTAL CONDITIONS, WIND SPEED, AND EXPOSURE DURATION DURING MIXED-SMOKE OBSCURANT TESTS

Test	Date	Temp. (C°)	RH (%)	Wind Speed (m/s)	Duration (min)
<u>Trial Tests</u>					
MS-1	6/30/87	26.2	42	0.9	206
MS-2	7/1/87	23.7	59	0.9	223
MS-FOT1	1/29/88	~21	~50	1.8	380
<u>Range-Finding/Wind Speed</u>					
MS-3	7/13/87	22.5	53	0.92	212
MS-4	7/14/87	21.8	55	1.83	210
MS-5	7/15/87	21.6	49	2.73	210
MS-6	7/16/87	20.8	52	4.57	210
<u>Cumulative Dose</u>					
MS-7	1/19/88	21.2	52	1.79	418
MS-8	1/21/88	21.6	52	1.81	413
MS-9	2/1/88	21.6	52	1.78	420
MS-10	2/3/88	21.1	50	1.77	420
MS-13(FO)	2/11/88	22.7	~47	1.78	280
MS-14	5/16/88	23.7	52	1.75	283
MS-15	5/18/88	23.3	51	1.82	282
MS-16	5/24/88	23.4	54	1.78	290
MS-17	5/26/88	23.4	52	1.70	292
<u>Average Test Conditions</u>					
<u>Range-Finding/Wind Speed</u>		21.7 ± 0.7	52.5 ± 2.6	0.9 to 4.6	
<u>Cumulative Dose</u>		22.4 ± 1.1	51.3 ± 1.9	1.78 ± 0.04	

TABLE 2.3. TEMPERATURE AND RELATIVE HUMIDITY AVERAGES AND FLUCTUATIONS DURING MIXED-SMOKES OBSCURANT TESTS

Test	Temperature			Relative Humidity		
	Average (°C)	±1 STD (C°)	No. (#)	Average (%)	±1 STD (%)	No. (#)
<u>Trial Tests</u>						
MS-12	6.2	0.59	20	42.3	3.0	40
MS-22	3.7	0.55	22	59.5	5.8	43
MS-FOT1	~21	-	-	~50	-	-
<u>Range-Finding/Wind Speed</u>						
MS-3	22.5	0.35	21	53.0	1.7	41
MS-4	21.8	0.36	21	55.3	2.2	40
MS-5	21.6	0.35	21	48.9	9.5	40
MS-6	20.8	0.19	20	51.9	7.7	41
<u>Cumulative Dose</u>						
MS-7	21.2	0.14	80	52.1	3.2	79
MS-8	21.6	0.39	79	52.4	4.0	79
MS-9	21.6	0.33	39	52.2	2.5	37
MS-10	21.1	0.75	41	50.4	1.9	41
MS-13(FO)	22.7	.38	28	~47	-	-
MS-14	23.7	0.13	27	51.5	1.5	87
MS-15	23.3	0.24	28	50.8	1.9	86
MS-16	23.4	0.23	27	53.5	2.7	86
MS-17	23.4	0.19	28	52.1	3.4	89

**TABLE 2.4. WIND SPEED AVERAGES AND FLUCTUATIONS DURING MIXED-SMOKE
OBSCURANT TESTS**

Test	Target Wind Speed (m/s)	Measured Wind Speed		No. (#)
		Average (m/s)	±1 STD (m/s)	
<u>Trial Tests</u>				
MS-1	0.89	0.9	0.05	--
MS-2	0.89	0.9	0.05	--
MS-FOT1	0.89	1.8	0.05	--
<u>Range-Finding/Wind Speed</u>				
MS-3	0.89	0.92	0.05	--
MS-4	1.79	1.83	0.05	--
MS-5	2.69	2.73	0.07	--
MS-6	4.48	4.57	0.05	--
<u>Cumulative Dose</u>				
MS-7	1.79	1.79	0.06	96
MS-8	1.79	1.81	0.03	80
MS-9	1.79	1.78	0.03	192
MS-10	1.79	1.77	0.03	195
MS-13(FO)	1.79	1.78	0.03	128
MS-14	1.79	1.75	0.21	52
MS-15	1.79	1.82	0.04	51
MS-16	1.79	1.78	0.17	88
MS-17	1.79	1.70	0.07	84

2.3 SMOKE (AEROSOL) GENERATION

Mixed-smoke aerosols were generated and introduced into the wind tunnel continuously during each test to maintain a sequence of physical and chemical aerosol characteristics for measurements of transport, transformations, and effects on plant, soil, microbe, and other test subjects. Because physical and chemical characteristics of aerosols change as they age following generation by combustion, mixed smoke aerosols were

introduced into the wind tunnel sequentially as described above and allowed to age during the exposure tests. The sequence of generation was HC then FO then WP. This sequence was selected to correspond to current training procedures employed at U.S. Army training sites (Battlefield Tactics Manuals TRADOC PAM 525-3 and FC 350-1). Consequently, the composition of the mixed aerosol was HC during the first third of most tests, FO mixed with lesser quantities of HC during the middle third, and WP with trace quantities of FO and HC present during the final third of most tests. Average target aerosol mass concentrations were selected based on mid- to upper-range concentrations expected in the field, and were 600 mg/m³ for HC and FO, and 2000 mg/m³ for WP.

2.3.1. Test Materials and Generation Procedures

Materials and procedures for the preparation and combustion of HC, FO, and WP have been described in previous reports, and are described here in less detail. Sketches of the three types of aerosol generation devices are shown in Figures 2.3 through 2.5.

Hexachloroethane

(HC + Zinc Oxide + Al).

5 - 50 g per pot.

6 - 14 pots per test.

Tin Can on sand surface.

Hot wire igniter (30A).

Combustion: Dirty white plume,
some ash ejected.

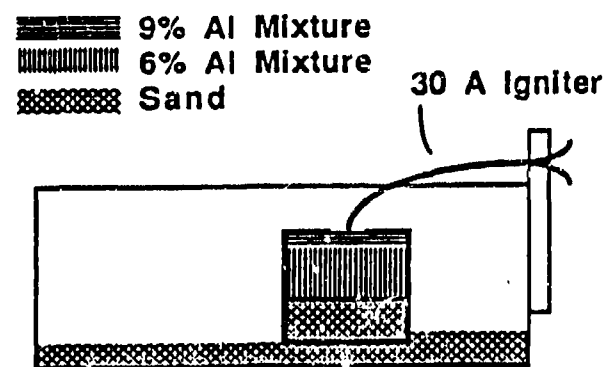

FIGURE 2.3. MINIATURE HEXACHLOROETHANE (HC) SMOKE POT AEROSOL GENERATOR FOR COMPUTER-CONTROLLED WIND TUNNEL EXPERIMENTS

Details of HC aerosol generation are described in Cataldo et al. (1989b), of FO in Cataldo et al. (1989a), and of WP in Van Voris et al (1987).

Fog Oil

Fog oil SGF-2.

Refrigerated under nitrogen.

1 - 10 ml/min feed rate.

Combustion: Flash vaporization.

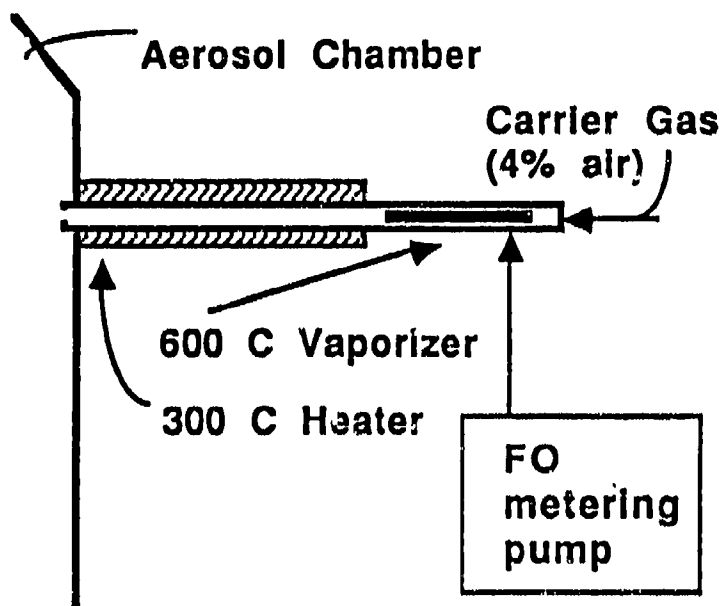

FIGURE 2.4. TEMPERATURE-CONTROLLED FOG OIL (FO) AEROSOL GENERATOR

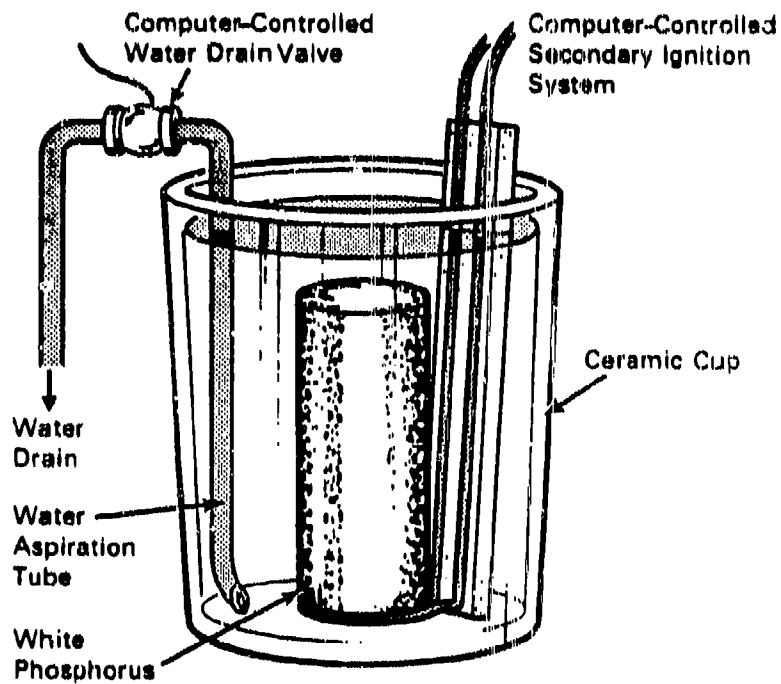
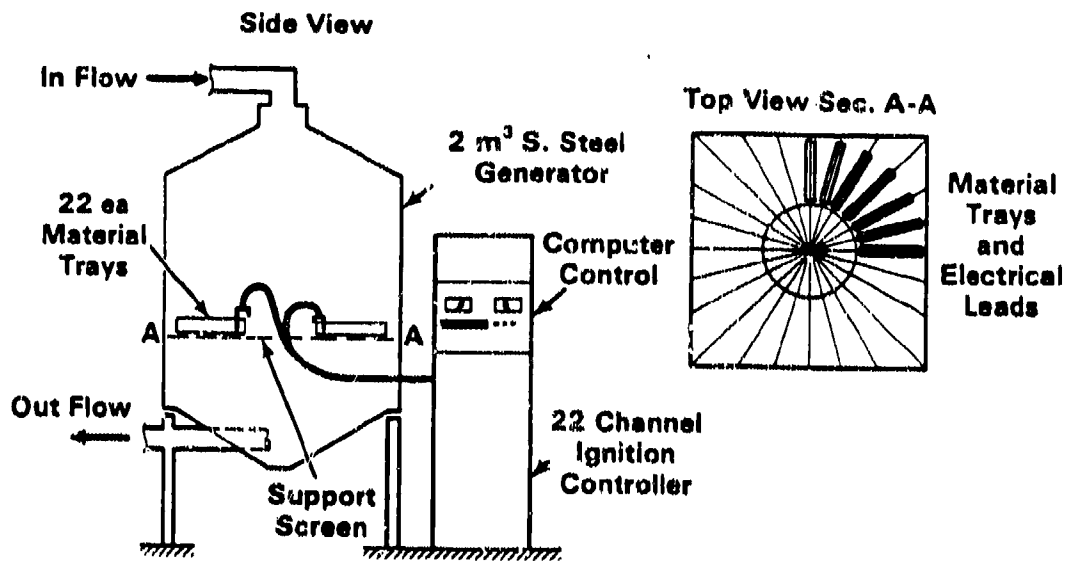

FIGURE 2.5. WHITE PHOSPHORUS (WP) AEROSOL GENERATOR. COMPUTER CONTROL WAS USED TO ASPIRATE BATH WATER AND THEN IGNITE PURE WP.

The HC was prepared by mixing hexachloroethane crystals with ZnO and Al powders. Materials were obtained from commercial chemical suppliers. Two batches of HC mix were prepared; both contained a ZnO to HC ratio of 1.04; however, one batch contained 9% Al, and one batch contained 6% Al. The HC pots for combustion were manufactured by compacting the mixtures into 1-oz gill-style tin cans with 3/8-in.-dia holes in the center of each lid. Clean white-quartz sand was used to fill the bottom of each pot to allow the HC mixtures to be packed near the top of the cans to a density of $1.75 \pm 0.15 \text{ g/cm}^3$. The higher Al mixture was used in the top 20% of the total compacted HC load in each can. This was approximately prototypic and was done to ensure rapid ignition. One 29.5 or 39 g HC pot was ignited at the beginning of each test, followed by four, five, or six 12 or 16 g HC pots; the actual number depended on the duration of the HC portion of each test, and the actual mass depended on the combustion interval. Thirty-A hot wire inserts were used via the computer system to ignite the HC pots at 15- or 20-min intervals during the first third of each test.

Differences between miniature HC pots and the 30-lb pots in the Army's inventory included size (a 20-g HC pot contained 0.15% of the charge of a 30-lb HC smoke pot) and composition; 30-lb smoke pots contain a lesser fraction (less than 20%) of the high-aluminum mixture and also contain a thermite igniter. The small size of the miniature HC pots did not make feasible the use of a thermite starter, and the larger fraction of high-aluminum mixture was required to ensure that the hot wires used as starters would make contact with the mixture containing 9% aluminum.

Before each test, HC pots were placed into the $\sim 3\text{-m}^3$ buffer tank of the aerosol generation system and prepared for ignition. Each HC pot was placed on a sand surface in a stainless steel tray and connected to a hot wire starter. Contact was made between the HC pots and the starter wires by piercing the protective paper and inserting the wire about 0.5 cm into the compacted HC charge. The chamber was then sealed, and the generator system was powered and connected to the computer. Hot wires were energized for 20 to 30 s to initiate combustion. The HC pots burned vigorously and emitted a dirty white plume and flaming ash. Figure 2.6 shows an ignited HC pot. Temperature measurements and visual observations made during these and previous tests (Cataldo et al. 1989b) indicated that the mixtures attained a temperature of about 620°C within about 3 or 4 s of ignition, burned for a total of about 10 to 13 s, and caused the tin containers to glow with a red color. Smoke from each HC pot was mixed in the buffer tank and drawn into the wind tunnel at a location downwind of the test section.



FIGURE 2.6. HEXACHLOROETHANE POT GENERATING SMOKE IN THE AEROSOL GENERATOR BUFFER CHAMBER

FO obscurant is produced in the field by vaporizing liquid fog oil. Obscurant smoke forms as the vapors cool, condense, and form a liquid-droplet mist. The FO generated during these tests was SGF-2 oil supplied by the U.S. Army, and was identical to that used previously (Cataldo, et al. 1988). The fog oil used in all tests, other than trial tests MS-1 and MS-2, was from a 55-gal barrel designated: SGF-2-3, Fog Oil, MIL-F 12070B, Type SGF-2, 9150-00-261-7895, Lot #1, DLA Goo-83-C-1284, Date MFD 7-83. The fog oil was stored under a nitrogen atmosphere to prevent oxidation and the possible formation of sludge. No discoloration or sludge formation was observed during or subsequent to the mixed-smokes experiments. The FO used during tests MS-1 and MS-2 was from another barrel, and was amber colored; possibly due to oxidation that occurred prior to receipt of the barrels at PNL several years ago. These two trial tests did not include plant or other test subjects and were only performed to test aerosol generating and characterizing instrumentation and procedures.

FO aerosols were produced in the wind tunnel using a vaporization/condensation method. Liquid FO was pumped onto the surface of an immersion heater maintained at 600°C. Vapors were then transported through a tube heated to 300°C to the wind tunnel aerosol generation chamber, or buffer tank, via a gas stream consisting of 96% nitrogen and 4% air. The resulting oxygen composition of the gas stream was approximately 0.8%, a value selected to represent the depleted oxygen content of typical diesel-engine field generators. The flow rate of oil into the generator was controlled at 1.3 or 3 ml/min during the first 20 or 25 min of each FO portion of mixed-smokes tests to provide rapid concentration build-up, and at 0.6 or 1.5 ml/min during the remainder of each test. A liquid oil pump failure that occurred during test MS-7 and MS-8 caused low FO concentrations; a new pump was used during subsequent tests.

White phosphorus aerosols were generated by combustion in a manner similar to that used for HC aerosols. Sections of pure white phosphorus were employed in the wind tunnel experiments rather than the mixture of white phosphorus and felt used in WP munitions because the non-uniform distribution of WP in the munitions (reported by Spanggard et al. 1985) would have degraded our ability to control aerosol concentration in the relatively small scale of the wind tunnel. Pure WP was obtained from a commercial supplier. The yellowish-white material was similar to wax in appearance and texture.

Sections of WP were cut and placed in masses of 18 or 24 g and 9.5 or 11.5 g into ceramic cups. Tap water was used to cover the WP and the cups were placed into the aerosol generation chamber. Cups were drained and ignited automatically using the computer system. Ignition was facilitated using 10 A nichrome heaters. Two of the larger masses were ignited at the beginning of the WP portion of the tests, followed by three to six of the smaller masses, depending on test duration. The interval between ignitions was 15 or 20 min.

Ignitions were followed by combustion for about 10 to 15 min. In contrast to the combustion of HC pots, WP burned with a lazy flame and occasionally released molten droplets rather than flaming ash.

2.3.2 Aerosol Generation

A combination of range-finding, wind speed, cumulative dose, and fog oil only test series were generated to perform test trials. Tests were typically performed by sequencing all three types of obscurants: HC then FO then WP. A listing of tests, sequence of generation, quantities or rates generated, and intervals between material combustion periods is shown in Table 2.5. The quantity or rate of generation is listed in the table as mass (HC and WP) or mass flow rate (FO). The greater masses and rates were generated initially in order to rapidly bring the concentration of aerosol in the wind tunnel to target conditions. Typically, one large HC pot and two large WP cups were ignited at the beginning of the first and third portions of each test, respectively. FO was generated at the greater rate for 20 or 25 min at the beginning of each FO period. In the table, period of generation refers to the interval between ignitions of HC and WP masses and to the method of generating FO by continuously pumping liquid oil onto a 600°C immersion heater.

2.4 SMOKE (AEROSOL) CHARACTERIZATION

Mixed smoke aerosols were characterized during each wind tunnel test. Measurements were made to provide information on aerosol mass concentration, particle size distribution, and aerosol chemical composition. Aerosol mass concentration and aerodynamic particle size distribution are important physical characteristics of aerosols that affect dose and effects of obscurant aerosols on the environment. The mass concentration of suspended particles is the characteristic most directly linked to the dose, or mass loading of aerosol particles to environmental surfaces such as plants, soil, and water. The aerodynamic particle size distribution of obscurant aerosols has important influences on transport and deposition rates. Large particles deposit more readily under the influence of wind speed and gravitational forces and small particles by diffusion. In addition to physical characterization of test aerosols, the chemical composition of mixed smoke aerosols was measured during most tests to measure relative levels of specific components of the aerosols, for both the airborne and the deposited particulate matter. Analyses of data provided information for specific times during the exposures and for the average of aerosol characteristics during tests. In addition, surrogate surfaces were analyzed to determine the rate of particle deposition, or deposition velocity, for comparison with plant, soil, and water surfaces.

TABLE 2.5. OBSCURANT SMOKE SEQUENCE AND GENERATION PROCEDURES FOR MIXED-SMOKE TESTS

Test	Aerosol Generation Sequence	Quantity or Rate			Period of Generation	
		HC (g)	FO (mL/min)	WP (g)	HC & WP (min)	FO (-)
<u>Trial Tests</u>						
MS-1	HC/FO/WP	27/11	~5/~3	26/13	15	Cont.(a)
MS-2	HC/FO/WP	22/11	~1.3/0.8	26/13	15	Cont.
MS-FOT1	FO	-	1.0/0.8/1.6	-	-	Cont.
<u>Range-Finding/Wind Speed</u>						
MS-3, 4, 5, & 6	HC/FO/WP	29.5/12	~1.3/0.8	18/9.5	15	Cont.
<u>Cumulative Dose</u>						
MS-7 & 8	HC/FO/WP	39/16	<1.3/<0.8	24/11.5	20	Cont.
MS-9 & 10	HC/FO/WP	39/16	3.0/1.5	24/11.5	20	Cont.
MS-13(FO)	FO	-	3.0/1.5	-	-	Cont.
MS-14 & 15	FO/WP	-	3.0/1.5	24/11.5	20	Cont.
MS-16 & 17	HC/FO	39/16	3.0/1.5	-	20	Cont.

(a) Cont. = continuous generation (FO).

2.4.1 Aerosol Mass Concentration

Aerosol mass concentration was measured using isokinetic sample probes and a laser transmissometer. Unlike previous tests, the aerosols during mixed-smoke tests were often mixtures of two or three types of obscurants. Chemical analysis of filter probe samples provided information that was then used to determine dose terms for each obscurant present in the mixed smokes. Procedures used to accomplish this are discussed in more detail in Section 2.4.3.

Isokinetic air samples were collected periodically at 15- to 30-min intervals during each test as the primary aerosol concentration measurement. The samples were obtained by drawing known volumes of the wind tunnel atmosphere at a steady flow rate through a

sharp-edged nozzle oriented into the wind. Samples were obtained about 100 cm downwind of the wind tunnel test section. Sample flow rate was controlled using orifice meters operated at critical pressure drop, flow rates were verified by passing the sample flow through a flowmeter. Isokinetic sampling was performed; the sample flow rate was maintained such that the velocity present in the probe approximately equaled that in the approaching air stream. The diameter of the nozzle was 0.48 cm. Particulate matter was collected on 25 mm glass fiber filters (Gelman, Ann Arbor, Michigan, Type A/E) located about 10 cm directly downwind of the leading edge of the nozzle. Due to the proximity of the filter to the nozzle, no probe sampling correction factor was required. The mass of each sample was determined within 30 to 60 s after removal from the wind tunnel atmosphere; then, the samples were either placed in a desiccator or contacted with distilled water, 0.1 N HNO₃, or iso-octane, for subsequent chemical analysis. Aerosol mass concentration was determined for each sampling period by a measured ratio of particulate mass to total sample volume.

Nearly continuous recordings of aerosol mass concentrations were obtained by operating a laser transmissometer during each test. These measurements were performed to provide a record of minute-to-minute variations and fluctuations occurring in the aerosol mass concentration. A He-Ne laser beam was propagated horizontally across the wind tunnel test section just upwind of the plants, and above the soils. The path length through the aerosols was 61 cm. The power of the incident and transmitted beams were measured at about 45 s intervals throughout each test. The ratio of transmitted (P_r) to incident (P_o) beam power was then recorded as a measure of the obscuration of the aerosol. These data were calibrated to indicate aerosol mass concentration by comparison with physical samples of the aerosols isokinetically collected on 25 mm glass fiber filters. The calibration of the transmissometer was restricted to actual aerosol mass concentration due to the dependence of aerosol obscuration on the physical properties of the aerosols, including particle size and index of refraction. No attempt was made to calibrate the system for a direct measure of other characteristics of the aerosols, such as desiccated mass, or specific compounds such as zinc or phosphorus; this was deemed not to be practical in part because of the changing aerosol composition throughout each test.

Transmissometer calibration relationships were determined for each test. The relationship of transmittance to aerosol mass concentration, shown for each test in Table 2.6, was seen typically to be best described by a logarithmic, or power equation, although a few tests were best fit using an exponential curve. Transmittance is known to be an exponential function of the extinction coefficient times the pathlength. That the transmissometer calibrations for the current experiments did not display a definite exponential trend may be due to fluctuations in the extinction coefficient caused by changing obscurants (HC, FO, and WP), aerosol aging, and concentration differences. Aging may have caused changes in the

TABLE 2.6. LAZER TRANSMISSOMETER CALIBRATION RELATIONSHIPS FOR MIXED-SMOKE OBSCURANT AEROSOL TESTS

Test	Smokes	Calibration Function	R ²
<u>Range-Finding/Wind Speed</u>			
MS-3	HC/FO/WP	$C_m = 81.46 \times (P_t/P_o)^{-0.8879}$	0.991
MS-4	HC/FO/WP	$C_m = 60.88 \times (P_t/P_o)^{-0.9794}$	0.988
MS-5	HC/FO/WP	$C_m = 65.90 \times (P_t/P_o)^{-0.9428}$	0.993
MS-6	HC/FO/WP	$C_m = 52.59 \times (P_t/P_o)^{-1.0506}$	0.992
<u>Cumulative Dose</u>			
MS-7	HC/FO/WP	$C_m = 3195.0 \times 10^{(-9.290 \times P_t/P_o)}$	0.981
MS-8	HC/FO/WP	$C_m = 3269.1 \times 10^{(-10.23 \times P_t/P_o)}$	0.910
MS-9	HC/FO/WP	$C_m = 87.60 \times (P_t/P_o)^{-0.7818}$	0.980
MS-10	HC/FO/WP	$C_m = 73.14 \times (P_t/P_o)^{-0.8414}$	0.989
MS-13(FO)	FO	$C_m = 843.4 - 3869.0 \times P_t/P_o$	0.992
MS-14	FO/WP	$C_m = 3872.8 \times 10^{(-9.960 \times P_t/P_o)}$	0.998
MS-15	FO/WP	$C_m = 3589.9 \times 10^{(-8.883 \times P_t/P_o)}$	0.976
MS-16	HC/FO	$C_m = 978.1 - 4103.0 \times P_t/P_o$	0.650
MS-17	HC/FO	$C_m = 836.6 - 2963.4 \times P_t/P_o$	0.642
<u>Trial Tests</u>			
MS-1	HC/FO/WP	$C_m = 57.00 \times (P_t/P_o)^{-0.9907}$	0.965
MS-2	HC/FO/WP	$C_m = 1208. \times (P_t/P_o)^{-0.0811}$	0.819
MS-FOT1	FO	$C_m = 1.804 \times (P_t/P_o)^{-1.8548}$	0.938
MS-FOT2	FO	$C_m = 15.63 \times (P_t/P_o)^{-1.0852}$	0.312

extinction coefficient due to changes in particle size and particle chemistry as water vapor was absorbed by the particles. Concentration may have also influenced the coefficient by driving coagulation and the resulting formation of larger particles at the greatest concentrations. In addition, particle deposition to the laser windows possibly occurred during some tests. Regardless, the goal of the current measurements, to provide a signal comparable to reference aerosol mass concentrations, was accomplished. Figure 2.7 shows calibration functions for four of the mixed-smokes tests.

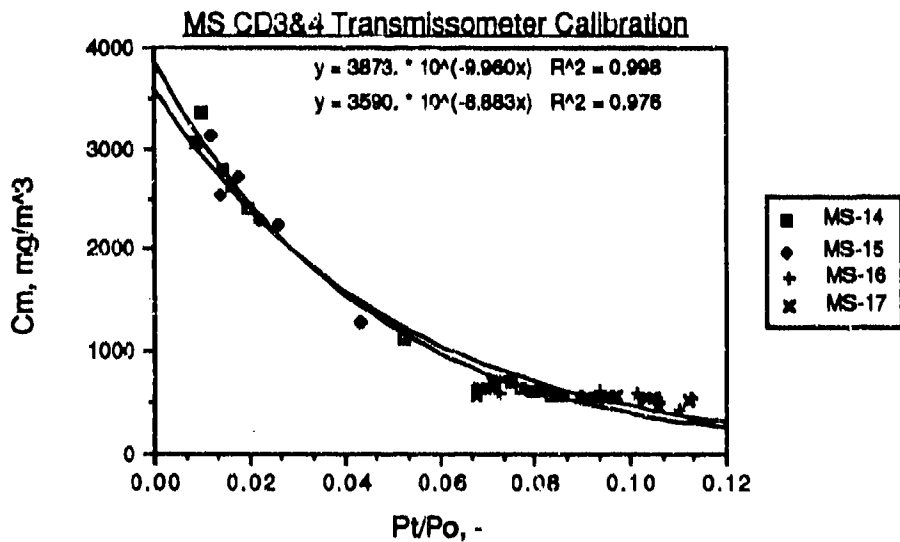
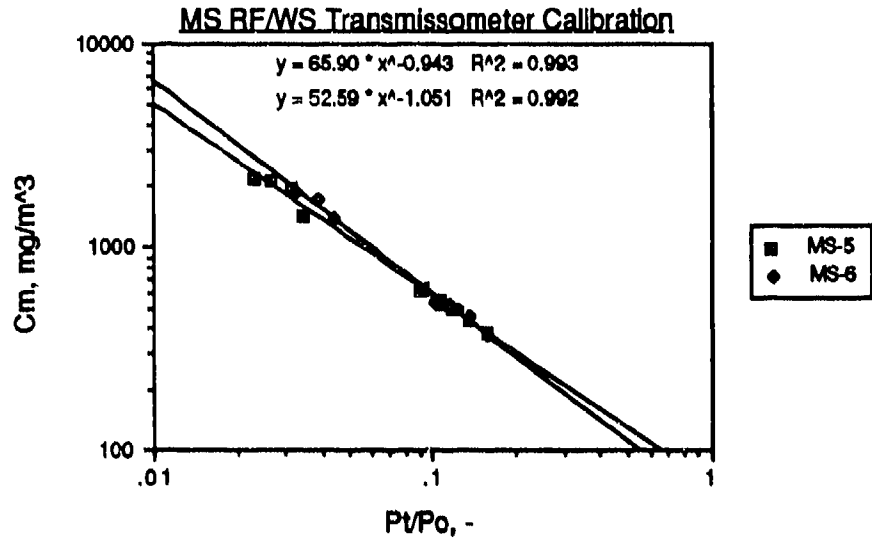

FIGURE 2.7. TRANSMISSOMETER CALIBRATIONS FOR FOUR SELECTED MIXED-SMOKE TESTS

The transmissometer calibrations ranged from <100 to 3,500 mg/m³. Although aerosol mass concentrations are discussed in the Section 3.1, a comparison of the concentrations determined by averaging the isokinetic filter samples and by analysis of transmissometer was made. Results of this comparison, which included 171 individual

measurements, are shown in Table 2.7. An example of the analysis for one test (MS-16) is shown in Table 2.8. Differences between calculated and measured average aerosol mass concentrations ranged from 0.1 to 4.7%. The average error, or the average absolute value of the difference between the two aerosol mass concentrations, ranged from 3 to 17% and generally reflected the coefficient of correlation of the calibration functions for each test.

TABLE 2.7. COMPARISON OF MEASURED AND TRANSMISSOMETER-DERIVED (CALCULATED) AEROSOL MASS CONCENTRATIONS FOR MIXED-SMOKE OBSCURANT TESTS

Test	Smokes	Calculated/ Measured	± 1 Std. dev.	Average Error	Error ± 1 Std. dev.
<u>Range-Finding/Wind Speed</u>					
MS-3	HC/FO/WP	1.002	0.058	0.045	0.035
MS-4	HC/FO/WP	1.002	0.062	0.049	0.035
MS-5	HC/FO/WP	1.001	0.054	0.035	0.040
MS-6	HC/FO/WP	1.001	0.052	0.041	0.030
<u>Cumulative Dose</u>					
MS-7	HC/FO/WP	1.005	0.103	0.085	0.055
MS-8	HC/FO/WP	1.033	0.265	0.203	0.166
MS-9	HC/FO/WP	1.004	0.101	0.069	0.072
MS-10	HC/FO/WP	1.003	0.078	0.054	0.055
MS-13(FO)	FO	1.047	0.098	0.075	0.076
MS-14	FO/WP	1.001	0.037	0.027	0.023
MS-15	FO/WP	1.006	0.114	0.087	0.069
MS-16	HC/FO	1.007	0.094	0.070	0.059
MS-17	HC/FO	1.004	0.068	0.049	0.045

Std. dev. = Standard deviation.

2.4.2 Mixed-Smoke Composition

The composition of mixed-smoke aerosols was measured during most tests. Measurements were performed on collected particulate mass from isokinetic filter samples and deposition coupons. Other samples were obtained during selected tests and included grab samples of the wind tunnel atmosphere collected using 100-mL glass syringes and alternate deposition coupon substrate (wet and dry petri dishes). From these samples, and from samples of plant tissue and surface soil, the chemical composition of mixed-smoke aerosols was determined for airborne particles and particles deposited to various surfaces. In addition, because of the mixtures of smoke types present in the aerosol at any given time during the exposures, the chemical composition was in a constant state of flux. The duration of each

TABLE 2.8. COMPARISON OF MEASURED AND TRANSMISSOMETER-DERIVED (CALCULATED) AEROSOL MASS CONCENTRATIONS FOR TEST MS-16. P_v/P_o WITH NO AEROSOL PRESENT EQUALED 0.2497 ± 0.0013 PRE-TEST, AND 0.2457 ± 0.0013 POST-TEST. Std. dev. = ONE STANDARD DEVIATION

Test MS-16	Filter Sample	Time (h)	P _v /P _o (-)	Measured (mg/m ³)	Aerosol Mass Concentration	
					Calculated (mg/m ³)	Calc/Meas (-)
Avg:						
	F1	07:58	0.1128	560	515	0.920
1.007	F2	08:17	0.1054	550	546	0.992
Std:						
	F3	08:37	0.1020	550	560	1.017
0.094	F4	08:58	0.1016	590	561	0.951
Avg. Error:						
	F5	09:17	N D	630	N D	-
0.070	F6	09:57	0.0934	620	595	0.959
Std. Error:						
	F7	10:27	0.1104	440	525	1.193
0.059	F8	10:47	0.0743	750	673	0.898
Max. Error:						
	F9	11:08	0.0717	710	684	0.963
0.193	F10	11:27	0.0725	700	681	0.972
Min. Error:						
	F11	11:47	0.0703	650	690	1.061
0.008	F12	12:27	0.0725	590	681	1.154

smoke and the average concentration of its component used in measuring deposition to test subjects were determined. These components were zinc (for HC), hydrocarbons (for FO), and total phosphorus (for WP). Although the relative masses of zinc and phosphorus were small compared with the total mass of the HC and WP aerosols, the mass of hydrocarbons was nearly equal to the total mass of FO aerosols. Additional details of inorganic and organic individual components of the mixed smoke aerosols are discussed in Sections 2.5 and 3.2.

The water fraction of mixed-smoke aerosols was measured by comparing fresh to desiccated mass of isokinetic filter samples. The difference between the two measurements was attributed to the fraction of the aerosols consisting of free, or chemically unbound, water on the particles. As tests were performed at mid-range humidities, water contents of one-fourth or greater were expected during periods of the tests dominated by HC and WP aerosols and much less than one-fourth during the FO portions of the tests. Results of these measurements were used to provide information for a table of the composition of the mixed smoke aerosols, during all three portions of most tests.

Dose terms were determined for the three components of the mixed-smoke aerosols that were analyzed from samples of the test subjects: zinc, hydrocarbons, and phosphorus. This was done to determine the relative dose of each component and to allow calculation of the deposition velocity of each component. Because of the sequential generation of smokes (HC, FO, WP), and because residual fractions of previous smokes were present in the following test portions, the period of exposure of test subjects to HC was longest, that of FO intermediate, and that of WP shortest. Consequently, the average concentration of HC was least, and that of WP was greatest, even though the aerosol mass concentrations of the components during each portion of the test were approximately equal to the target values (600 mg/m³ for HC and FO, and 2000 mg/m³ for WP).

Dose terms, in mg/m², were calculated using the deposition velocity of individual components of the aerosols to the suspended 47-mm coupons, the duration of the presence of each component, and the average concentration of the component. As components were mixed, the time history of HC (zinc) concentration residuals following cessation of generation were determined by analyzing isokinetic filter samples for relative amounts of zinc. Results of these measurements are shown in Figure 2.8. The HC residual may have been greater than usual during the first half of the FO portion of tests MS-9 and MS-10 because of continued

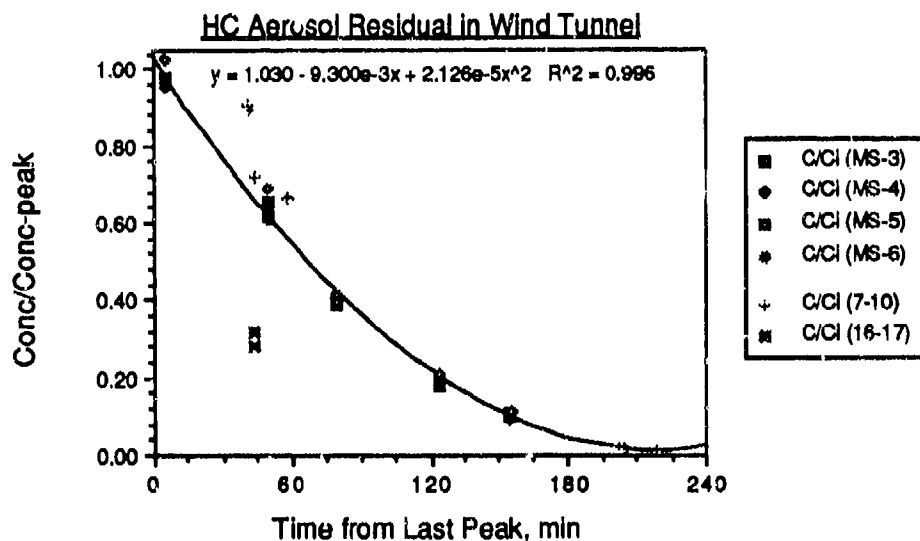

FIGURE 2.8. TIME HISTORY OF HC AEROSOL RESIDUAL ZINC CONCENTRATION DURING SUBSEQUENT (FO AND WP) PORTIONS OF MIXED-SMOKE AEROSOL TESTS

supply of HC aerosol by the aerosol generation chamber for a period of several minutes. The HC residual was lower than normal during the FO portion of tests HC-16 and HC-17 because the test section was isolated between the two portions of these tests (no WP was generated during these tests) in order to include test subjects and deposition substrates for the analysis of FO deposits. A loss rate of about 1.5%/min was found to approximate the disappearance of HC during the subsequent FO and WP portions of the tests. Determination was more difficult for FO as analysis for hydrocarbons was not accurate in the presence of zinc and phosphorus. Because of the similar particle sizes of FO and HC aerosols, the residual concentration history of FO during the WP portions of tests was assumed to be equal to that of the HC aerosol. No analysis was needed for WP (phosphorus) except for test MS-7 because WP was generated during the final period of all exposure tests. (One cup of WP was inadvertently generated early, during the HC portion of test MS-7 when the protective bath water was drained early.)

2.4.3 Particle Size Distribution

The size of particles that make up an aerosol often determine which forces, inertial or diffusive, control transport and deposition phenomena. The deposition velocity of particles to surfaces varies with the particle size; typically, particles with aerodynamic diameters between 0.1 and 1 μm deposit to natural surfaces such as plants, soil, and water, less quickly than smaller or larger particles. This difference exists because even smaller particles are strongly affected by diffusive forces and larger particles by inertial forces. Obscurant aerosols consist mostly of particles with physical (or actual) diameters about and slightly less than 1 μm ; however, the relatively fewer particles present in the obscurant cloud with diameters greater than 1 μm typically contain most of the mass of the suspended particulate matter. The size distributions of obscurant aerosols produced by combustion are often log-normal and may thus be characterized by a mean or median size and a standard deviation.

Measuring the particle size distribution of an aerosol (the frequency of particle occurrence as a function of particle diameter) is important in describing an aerosol's physical characteristics. The particle size distribution of an aerosol may be based on particle number frequency, aerosol mass, or other parameters such as surface area or particle volume. The particle size distributions of the mixed-smoke aerosols generated in this study were characterized by aerodynamic diameter rather than actual physical diameter. Determination of aerodynamic diameter provides information on the inertial characteristics of suspended particles. This method also accounts for the effects on particle transport caused by the shape of the individual particles that make up an aerosol without requiring actual characterization of particle shape.

Particle size distributions of mixed-smoke aerosols were measured during most tests to provide information on particle size for comparison with transport and deposition measurements and to determine the influence of aging, aerosol mass concentration, and environment (relative humidity) on particle size. Measurements were typically performed at the midpoint of each third of the tests so that the particle size distribution associated with each major smoke could be identified. Measurements were also made sequentially during a single portion of a test to demonstrate the repeatability of the procedure.

Mixed-smoke aerosols were sampled using an eight-stage Andersen ambient-style cascade impactor operated at approximately 26 Lpm. This device provided classification of the suspended particles in the HC aerosols by separating sampled particles into nine different aerodynamic sizes ranging from approximately 0.5 to 10 μm . Samples were drawn from the wind tunnel 6 m downwind of the test section, from an area of low wind speed. This allowed accurate sampling of the larger particles in the aerosols by reducing isokinetic sampling requirements. Each stage of the impactor was covered with a pre-weighed, 81 mm flat glass fiber substrate which was used to collect depositing particulate mass. Collection substrates were weighed after each sample, and the particulate mass, along with the sampling flow rate were analyzed to provide particle statistics.

2.4.4 Particle Deposition Velocity

The rate of deposition, or the deposition velocity, of mixed smoke obscurants to suspended coupons was measured. This was done to provide a point of comparison with deposition velocities measured to plant and soil surfaces. Six 47 mm flat glass fiber filter pads were suspended in the wind tunnel test section above the soil coupons and just upwind of the plants. The deposition coupons were oriented horizontally, with the edge into the wind. Support was provided behind the coupons by stiff springs suspended vertically from the ceiling of the test section. The coupons were sandwiched between coils of the springs. The coupons were oriented upwind of the springs, and three coupons were attached to each spring. The vertical locations of the filters ranged from about 10 to 50 cm above the floor.

Coupons were weighed prior to and following the tests. Following the post-test analysis, the coupons were either placed into desiccators or prepared for chemical analysis by contact with water, 0.1 N HNO_3 , or iso-octane. Deposition velocity was determined for each sample by the equation: $U_d = (1.667 \times 10^4) \times (M \times A) / (C_m \times \Delta t)$, where U_d is the deposition velocity in cm/s, M is the mass deposited to the sample in mg, A is the surface area of the deposition coupon in cm^2 , C_m is the average aerosol mass concentration in mg/m^3 over the duration of the test, Δt , in min. Surface area was determined to be 34 cm^2 , the area of the top and the bottom of the filter surface, less the area of the filter covered by the spring support. Optionally, as the nearly all deposition was to the top of the coupons (indicating sedimentation was an important depositional process) the area could have been considered to be only the top of the filters, or 17 cm^2 . For the current studies, the area was

determined using both top and bottom to correlate with the method used for plant leaf determination.

2.5 SMOKE CHEMICAL CHARACTERIZATION

2.5.1 Characterization Methods

Mass collection filters, impingers, wet (deionized water) and dry (polystyrene petri dish covers) deposition surfaces, and suspended (prewashed glass fiber filters) deposition surfaces were used to characterize the smokes. Soils were exposed during MS3 and MS5 tests. All analyses for aerosol metal constituents were done by Jarrell Ash Model 750, Waltham, Massachusetts, inductively Coupled Argon Plasma emission spectrometry (ICAP) on the leachate solutions. Chloride and phosphate analyses by Ion Chromatography (IC) were performed on the water extracts of filters and deposition surfaces. AS1, or AS3 (Dionex, Sunny Vale, California), columns and a standard eluent of 3 mM NaHCO₃ + 2.4 mM Na₂CO₃, or, AS4A (Dionex, Sunny Vale, California), columns and an eluent of 1.85 mM Na₂CO₃ + 1.75 mM NaHCO₃ were used. Chloride analysis of acidic extracts (0.01 M HNO₃) of filter or deposition surfaces were limited to the AS1 or AS3 columns. Dionex, Sunny Vale, California, IC models, 10 or 16 with conductimetric detection were used throughout.

Isokinetic aerosol filter samples were collected during tests MS2-MS6 using pre-acid-washed 25 mm glass fiber filters. With few exceptions, sampling time was held at 5 minutes. A flow rate of 1 L/min was used for tests MS-2 through MS-4, 1.5 L/min for MS-5, and 2.5 L/min for MS-6. Following initial (fresh) mass determinations, one-half of the filters were desiccated for 24 hours prior to reweighing for dried particulate mass determinations. For inorganic component analysis, filters were leached in 0.01 M HNO₃.

Samples from aqueous impingers containing 50 mL deionized water were collected during each of the three phases of aerosol generation during the early MS tests. No impingers were included for inorganic constituent analysis during MS7-17.

Deposition filters (47 mm glass fiber) were pre-acid-washed prior to exposure in the aerosol flowpath using the spring technique for simulation of plant leaf exposures. All

(Cataldo et al. 1989b) deposition filters collected during MS tests were desiccated for 24 h before mass determination, unless otherwise noted, because previous experience has shown that true fresh weight determinations were unattainable because of moisture loss during exposure and before initial weighing. Nominally 100-mm polystyrene petri dish covers were used for collection of deposition onto wet (deionized water) and dry surfaces during the mixed- smoke tests.

2.5.2 Soil Treatments and Characterization

Only surface soils were selected for exposure to the mixed-smoke aerosols, because deposition of smoke particulate would be a surface-loading phenomenon. As in earlier smoke studies (Van Voris et al. 1987; Cataldo et al. 1989a; Cataldo et al. 1989b), thin layers of soils were exposed in an effort to reveal effects occurring on the surface that would be mitigated by the effects of dilution or soil-buffering capacity. Soils (Table 2.9) included a sandy loam (Burbank), a low-nutrient acidic silt loam (Maxey Flats), a basic soil (Yamac), and a more fertile soil (fresh Palouse). These soils were collected near benchmark soils in conjunction with regional soil conservation departments and maintained by PNL. Burbank and Palouse soils are used in growth of plants for exposures.

Fresh Palouse was recently collected and has not been dried; Maxey Flats was collected within the past 2 years and has been allowed to air dry. Although the drying and extended storage of soils can result in differing behavior relative to continually moist and aerobic soil, it provides the range of soil properties required for diverse studies and has necessitated the use of bulk storage for air-dried, mixed, and quartered soils. Analyses at different times, on different soil aliquots, by different laboratories results in a range of values (such as noted for the available phosphate determinations) where the higher values were obtained most recently by NaHCO_3 (pH>7) or $\text{NaC}_2\text{H}_3\text{O}_2$ (pH<7) extractions, with the resulting P determinations all reported as PO_4^{-3} .

Soils were exposed during tests MS-3 and MS-5. During test MS-3, duplicate 10 g (<40 mesh) aliquots of Burbank, Maxey Flats, Yamac, and Palouse soil were spread in thin layers in 150-mm nominal polystyrene petri dish covers. Fresh Palouse soil (<1 mm) was exposed at single 10 and 20 g (fresh weight) ratios in the petri dish covers, because of the

increased difficulty to spread the fresh moist soil evenly over the entire area. During test MS-5, duplicate aliquots of only Burbank and Maxey Flats soils were exposed.

Exposed and control soils were contacted with deionized water at a 10:1 water to soil ratio in polycarbonate Erlenmeyer flasks with open-celled foam closures, and incubated for up to 15 days at 25°C, 60 rpm, in the dark. Sampling intervals of 1, 2, 5, 9, and 13 or 15 days were chosen, similar to previous studies. Analyses included pH and major and minor anions and cations. Analysis of ammonia was added during current tests, in an attempt to determine the stage of microbial development as reflected by the $\text{NH}_4^+/\text{NO}_2^-/\text{NO}_3^-$ solution components.

TABLE 2.9. SELECTED PROPERTIES OF SOILS USED IN AEROSOL EXPOSURES

Property	Burbank	Maxey Flats	Ritzville	Yamac	Shawano	Quillayute	Palouse
% Sand	45.1	20.6	43.6	26.2	70.6	10.8	1.1
% Silt	51.4	65.4	43.9	46.4	14.5	62.2	77.5
% Clay	4.0	14.2	12.5	27.8	14.7	27.0	21.4
% Ash	98.0		96.9	96.5	83.8	70.2	93.8
pH (100% field capacity)	7.43	4.41	6.20	8.43	4.82	4.74	5.6
Org.C (%)	0.52	2.22	0.54	0.74	13.7	12.9	1.88
Sulfur (%)	0.053	ND ^(a)	ND	0.025	0.084	0.124	0.043
Nitrogen (%)	0.061	0.22	0.09	0.095	0.67	0.89	0.18
Total P ($\mu\text{g/g}$)	2400.0	ND	1420.0	716.0	1440	3900.0	3770.0
$\text{PO}_4^{3-}\text{-P}$ ($\mu\text{g/g}$)	5-24	2.4	ND	7-46	7.6	0.13	6-50
Carbonate/bicarb.(%)	<0.5	<0.5	<0.5	4.65	<0.5	<0.5	<0.5
Ammonia-N ($\mu\text{g/g}$)	6.1	63.0	9.0	99.0	45.0	36.0	18.3
CEC (meq/100 g)	5.5	12.6	14.4	25.5	28.0	45.1	23.8

^(a) ND = not determined.

2.6 PLANT AND SOIL SELECTION AND CULTIVATION

2.6.1 Plant Selection and Cultivation

The native species selected, including sagebrush, ponderosa pine, and short-needle pine are found associated with different training environments throughout the United States or used in revegetation, while bush bean (used as a sensitive indicator species for soft crops), the pines and grass are important agronomic species found adjacent to many training installations.

Plant sources and characteristics are as follows:

- Big sagebrush (Artemisa tridentata, vaseyana). A medium-sized, perennial shrub found over vast expanses of the arid and semi-arid western states. It grows in relatively harsh environments on alkaline soils and at elevations from sea level to 7000 ft. Source: Native Plants Inc., Sandy, Utah. Age: 2-year-old seedlings.
- Ponderosa pine (Pinus ponderosa). A large coniferous forest species common to western North America. It grows at a range of elevations and is relatively tolerant to drought. It requires moderate soil fertility. Source: MacHugh Nursery, Eltopia, Washington. Age: 2-year-old seedlings.
- Short-needle pine (Pinus echinata). A coniferous tree species indigenous to the southeastern United States. This variety is used extensively in reforestation. Source: J.P. Rhody Nursery, Gilbertsville, Kentucky. Age: 2-year-old seedlings.
- Tall fescue (Festuca elator). A perennial, cool season bunch grass that grows well on dry or wet, alkaline or acidic soils, and has a rather ubiquitous range. Source: Native Plants, Sandy, Utah. Grown from seed.
- Bush bean (Phaseolus vulgaris, tendergreen). An agronomic species that is relatively sensitive to chemical insults based on previous experience. Grown from seed.

These five plant species provided a range of canopy type, cuticular structure, and thickness and were suitable for evaluating phytotoxic response to obscurant smokes and deposition velocity under a range of environmental conditions. Ponderosa pine, short-needle pine, and sagebrush were maintained in the greenhouse before use. These species were

allowed to go dormant in the fall of the year; in December, the greenhouse temperature was increased, and photoperiod was artificially adjusted to break dormancy. Before their experimental use in the spring, groups of these plants were transferred to growth chambers and allowed to equilibrate for 30 days; they were maintained at day/night temperatures of 32°C/21°C, a 16-h photoperiod (approximately 500 $\mu\text{E m}^{-2} \text{s}^{-1}$, PAR, at leaf surface), and 50% relative humidity. Bush bean was planted and grown in growth chambers under the same conditions. Tall fescue was grown from seed and maintained at day/night temperatures of 27/15°C, a 10-h photoperiod (approximately 500 $\mu\text{E m}^{-2} \text{s}^{-1}$, PAR, at leaf surface), and 50% relative humidity.

Both pine species were grown on a commercially available loam soil, while the sagebrush, tall fescue, and bush bean were grown on Burbank silt-sand. The latter were used to evaluate direct foliar contact toxicity, and at no time was the soil of these test systems exposed to HC smokes.

2.6.2 Soil Selection and Characteristics

Two soils were used to evaluate indirect soil/plant effects. For this evaluation, soils were contaminated with FO smokes before the seeding and growth of the grass species. The two soils used were Burbank (found at Hanford, Washington), an alkaline silt-sand that readily supports the growth of the grass species, and Maxey Flats (found at Morehead, Kentucky), a silt-clay that is noncultivated, has low nutrient status, and will support marginal growth of the grass species. Physical and chemical properties of these soils are provided in Table 2.9. All soils were maintained at 50 to 66% of field capacity before and after experimental use. In addition, a Palouse silt-soil, typical of eastern Washington agricultural areas, was employed for the microbial tests.

2.7 PLANT/SOIL MEASUREMENTS

2.7.1 Foliar Contact Toxicity Responses

In evaluating direct foliar contact toxicity, plant canopies were exposed to smokes under a range of concentration, time, and atmospheric conditions. In all cases, soils were isolated from canopies by bagging the soil containers at the lower plant stem to preclude any indirect effects arising from soil contamination. All foliar exposures were conducted in the illuminated portion of the wind tunnel test section.

Toxicity responses arising from direct contact of smokes with foliar surfaces, namely those that are readily visualized or phenotypic, were evaluated using a modified Daubenmire

Rating Scale (Table 2.10). This nonparametric approach provides for a rapid comparison of gross toxicity and its relative intensity with time of post-exposure. In addition, grasses that are harvested 3 to 4 weeks after exposure (direct canopy effects) were permitted to regrow through one or more subsequent harvests, and dry matter production was monitored. Regrowth and monitoring allows for evaluation of any residual plant effects resulting from foliar absorption and root accumulation of smoke components.

TABLE 2.10. CODING FOR MODIFIED DAUBENMIRE RATING SCALE AND ASSOCIATED PHYTOTOXICITY SYMPTOMS

Symptom/Intensity	Description
Modified Daubenmire Rating Scale	
0	No obvious effects over controls
1	5% of plant foliage affected
2	Between 5%-25% of foliage affected
3	Between 25%-50% of foliage affected
4	Between 50%-75% of foliage affected
5	Between 75%-95% of foliage affected
6	Between 95%-100% of foliage affected
Phenotypic Responses	
OGA	Old growth affected
NGA	New growth affected
O&NGA	Old and new growth affected
TB	Tip or leaf edge burn
LBD	Leaf burn and leaf drop
NS	Necrotic spotting
LD	Leaf abscission or needle drop
CH	Chlorosis
BD	Blade dieback
LC	Leaf curl
W	Wilting
GD	Growing tip dieback
D	Plant dead
F/SA	Floral or seed/fruit abortion
(value)	Indicates the length in cm that needles or leaves exhibit dieback or burn

2.7.2 Photosynthetic Measurements

Oxygen Electrode (Polarographic) Measurements. Leaf samples were taken before, immediately after, and at several intervals after exposure for analysis of oxygen evolution and uptake. Leaves were excised from the plants, placed in moistened paper towels, and maintained on ice at approximately 4°C until assayed. They were then wet with distilled water and sliced with a razor blade into pieces <5 mm in length or diameter. The pieces were

transferred to an assay medium consisting of 2 mM CaCl₂, 10 mM sodium bicarbonate, and 20 mM N-2-Hydroxyethylpiperazine-N'-2-ethansulfonic acid (HEPES) pH 7.6. Paired tissue samples were taken from this solution and placed directly into paired, water-jacketed (3.9 ml of control media at 20±1°C) cuvettes. The suspension was continually stirred with magnetic stirrers. The cuvettes were then covered with aluminum foil for dark respiration for approximately 25 min, until a steady-state rate was obtained. They were then illuminated with saturating light (>1200 μEinstein m⁻²s⁻¹) at 600 nm for an additional 20 min to obtain a steady-state rate of photosynthesis. After illumination, the tissues were removed from the cuvettes, and blotted and dried overnight in a 75°C oven so the dry weight could be obtained. Assays were run in triplicate and the data expressed as μMol O₂ h⁻¹g dry wt⁻¹.

Infrared Gas Analyzer (IRGA) Measurements. The exchange of CO₂ from the plants may be measured by the use of an Infrared Gas Analyzer (IRGA). A gas analysis system was constructed in the wind tunnel and a simplified schematic of its components is given in Figure 2.12.

A Beckman Model 865 IRGA, Palo Alto, California, in the differential configuration was employed to measure differences in CO₂ concentration (μ/L) in air which had passed through the plant chamber versus that of the original filtered outside air (Figure 2.9). The cylindrical Plexiglass® plant chamber (45 l cm³) was placed in the same large growth chamber in which the plants were maintained during the exposure series to minimize environmental differences. Plant chamber temperature was maintained within ±1°C of the growth chamber. Light intensity at canopy level in the plant chamber was ~95% that of the growth chamber (400 μE m⁻²s⁻¹). Flow rates (10 Lpm) and backpressures were used to calculate rates of Net Carbon Exchange (NCE) (μMol CO₂/sec/plant). Measurements of individual plants were taken prior to exposure and at various times during the experiment. In addition, control plants not exposed to HC smoke were also measured intermittently over this period, to provide a point of reference.

2.7.3 Indirect Plant Effects

Indirect plant effects were evaluated by exposing Burbank and Maxey Flats soils to smoke aerosols. These soils (444 and 526 g dry weight of Maxey Flats and Burbank, respectively) were brought to moisture level, placed into 4.5-in.-diameter by 4-in.-high pots, the surface leveled, and pots exposed to smokes. Four days after being exposed, the soils were seeded with 15 tall fescue seeds. This approach resulted in contamination of only the soil surface; post-planting irrigation should result in some redistribution of smoke components down the soil profile. Indirect plant effects resulting from smoke contaminants deposited to

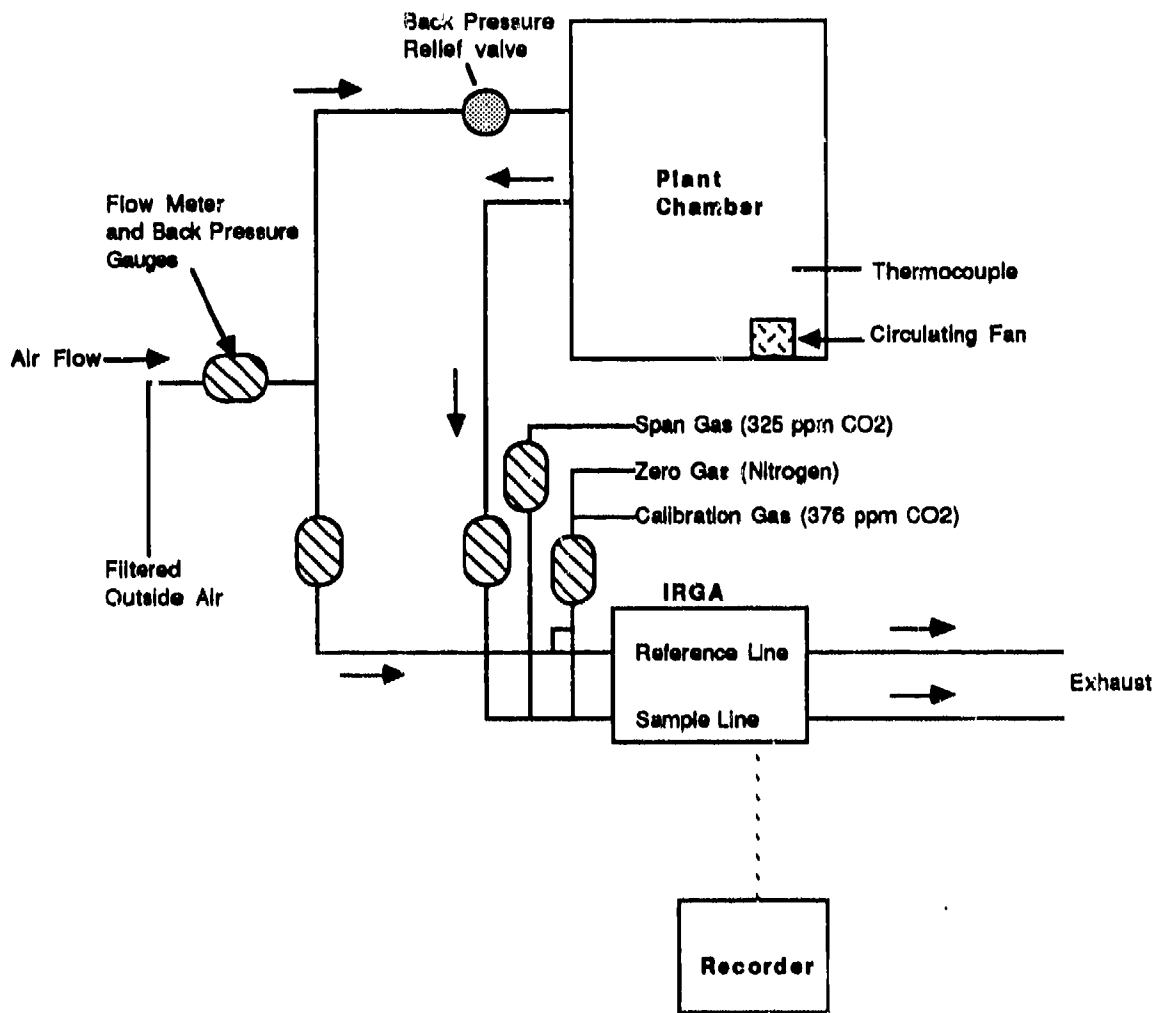

FIGURE 2.9. SCHEMATIC DIAGRAM OF GAS EXCHANGE SYSTEM USED IN MAKING NET PHOTOSYNTHETIC AND DARK RESPIRATION MEASUREMENTS.

soils were determined by evaluating percentage of germination and dry matter production using tall fescue as a test species. Dry matter production for plants grown on contaminated soils was followed through two or more harvests.

2.7.4 Quantitation of Exposure/Dose

The evaluation of plant toxicity responses to airborne contaminants requires a basis for intercomparison of treatments and variables. In all the toxicity studies, the point of reference is the mass loading value or exposure dose, as opposed to air concentration or exposure duration, to provide a specific dose value for each plant. The mass loading rate is determined by chemical measurement of the amount of smoke deposited to a unit area or weight of foliage, and is an absolute index of dose. In the case of FO smokes, total foliar FO hydrocarbons was determined by extraction of foliar samples (0.5 to 1 g) with 5 mL iso-octane. Mass loading to soils was estimated based on loading to filter coupons, dry Petri dishes, and wet Petri dishes followed by extraction as noted earlier. Quantitation of interception efficiency based on type of receptor surface (namely the type of canopy structure) is based on computed deposition velocities. The velocities are calculated from the air concentration, exposure duration, and the quantity of smoke (hydrocarbons) deposited per unit surface area.

The rates at which aerosols are deposited to the plant and soil surfaces in the wind tunnel, or the deposition velocities, were determined as functions of the FO mass concentration of the aerosols, mass deposited, and exposure duration. Deposition velocity results were compared for exposure variables including duration, relative humidity, and wind speed.

2.7.5 Post-Exposure Simulated Rainfall

The intensity of phytotoxic responses to foliar contaminants can be modified by the presence or absence of surface moisture. Immediately following exposure, subsets of exposed plants were subjected to a simulated rainfall (Figure 2.10) equivalent to 1.0 cm, as described in Cataldo et al. (1981). Simulated rainfall permitted evaluation of either the ameliorating effects of foliar surface wash-off, or any intensification of effects resulting from the presence of surface moisture and increased foliar uptake.

2.8 SOIL MICROBIOLOGICAL MEASUREMENTS

Two soils were used to evaluate the effects of mixed smoke exposure on soil microbiological properties: 1) Burbank sandy loam (sandy, skeletal, mixed, xeric, Torriorthent), a soil representative of the desert area of Washington, Oregon, and Idaho, with a low cation exchange capacity (CEC), low organic matter (OM), and a pH of 7-7.5; and 2) Palouse silt loam (fine-silty, mixed, mesic, Pachic Ultic Haploxerolls), an agricultural soil typical of eastern Washington, Idaho, and eastern Oregon, with a moderately high CEC and OM, and a pH of 5.6. Their physical and chemical characteristics are listed in Table 2.9.



FIGURE 2.10. APPARATUS FOR SIMULATING RAINFALL CONDITIONS

A range-finding/wind speed test series (RF/WS) and a cumulative dose test series were conducted on mixed smokes in the PNL Toxic Aerosol Test Facility as described below.

Large petri-dishes (150 X 15 mm) containing 50 g of air-dried Burbank sandy loam or Palouse silt loam soil were moistened with 10 ml of deionized water. For the RF/WS test series, soils were sequentially exposed to the smokes, hexachloroethane (HC), fog oil (FO), and white phosphorus (WP), at wind speeds of 0.92, 1.83, 2.73, and 4.57 m/s (Test No. MS-3, MS-4, MS-5, and MS-6, respectively) for 3.5 hours at a relative humidity of 49 - 55%. The concentrations of mixed smoke at these exposures ranged from 280 - 330 mg/m³ for HC, 145 - 147 mg/m³ for FO, and 1100 - 1390 mg/m³ for WP. Three cumulative dose tests with various smoke mixtures were conducted. For the MS-9/MS-10 cumulative dose tests, soils were exposed to HC/FO/WP mixed smokes twice (7 h each) for a total exposure time of 14 h, at a wind speed of 1.78 m/s, over a 3 day period. Soils were exposed twice (4.5 h each) over a 3 day period to FO/WP mixed smokes in the MS-14/MS-15 cumulative dose test. In the MS-16/MS-17 tests, soils were exposed twice to HC/FO mixed smokes for a total of 9 hours over a 3 day period. Soil moisture lost during each exposure was measured by weight loss and replaced by adding deionized water immediately after each exposure. Average moisture loss was about 90% after each exposure.

For the range finding/wind speed test series, Palouse soil respiration alone was measured immediately after the MS-6 test (4.57 m/s) exposure. Respiration was measured with an electrolytic respirometer incubation systems according to Knapp et al. (1983). After the smoke exposure, Palouse soil was transferred to pint-size mason jars. Unexposed (control) soil and exposed soil received 2 ml of deionized water while a second control soil received 2 ml of a 75 mg/ml glucose solution. Oxygen consumption was measured manometrically with electrolytic respirometers at a controlled temperature of 20°C. Respiration was measured periodically for two weeks. Each treatment was repeated twice.

For the cumulative dose tests, soil respiration was measured for both Burbank and Palouse soils by a modification of Anderson (1982). At post exposure time of 0 (3 days) and 4 weeks, eight grams of exposed and unexposed soil were placed in a specimen cup (120 ml size) together with a small vial containing 2 ml of 1 M NaOH to trap CO₂ evolved. A small vial containing water was also included in the specimen cup to maintain constant relative humidity for the incubation period. The cup was then sealed airtight with parafilm and a screw cap, and incubated in the dark at room temperature. After 10 days the alkali trap was removed and covered with screw cap with teflon seal. The carbon dioxide contained in the alkali trap was quantified as inorganic carbon by directly injecting 200µl of the NaOH solution into a carbon analyzer (Model DC-80, Dohrmann, Santa Clara, CA). Blank controls

consisted of same amount of alkali trap in the cup but without soil. Three replicates were used for each treatment. The amount of CO₂ evolved from the soil is calculated as follow:

$$\mu \text{ moles of CO}_2 = (S-B) \times V/12$$

where S = concentration of inorganic carbon ($\mu\text{g/ml}$) in the NaOH trap with soil.

B = concentration of inorganic carbon ($\mu\text{g/ml}$) in the NaOH trap without soil.

V = volume of alkali trap in ml, in this experiment the volume is 2 ml.

The mean values from exposed soil were compared with that of the control (unexposed) soil and expressed as a percent of the control.

Soil dehydrogenase activity was assayed with a modification of the procedure of Tabatabai (1982). Aliquots of soil (1.5 g wet weight) were mixed with 0.015 grams of CaCO₃, 0.3 ml of 1% glucose and 0.25 ml of the substrate, 2,3,5-triphenyltetrazolium chloride (3% w/v). After incubation at 22°C for 24 hours, 10 ml of methanol was added to the soil to stop the reaction and to extract the product, 2,3,5-triphenylformazan (TPF). The solution was mixed thoroughly, centrifuged, and the absorbance of the supernatant determined at 485 nm on a Beckman DU-50 spectrophotometer. Soil dehydrogenase activity, expressed as μg of TPF produced per g of dry soil per 24 hours, was determined by comparing absorbance values to a standard curve prepared with reagent grade TPF and methanol.

Soil phosphatase activity was assayed by the procedure of Tabatabai and Bremner (1969), as modified by Klein et al (1979). One g of soil was placed in 15 ml centrifuge tubes with 4 ml of modified universal buffer (MUB), which consisted of tris(hydroxymethyl)amino methane, 3.025 g; maleic acid, 2.9 g; citric acid, 3.5 g; boric acid, 1.57 g; 1M NaOH, 122 ml; in 250 ml final volume, pH 8.6. One ml of substrate p-nitrophenol phosphate (0.025 M prepared with MUB buffer), was added to each tube. The tubes were stoppered, vortexed and incubated for one hour at 37°C. One ml of 0.5 M CaCl₂ and 4 ml of 0.5 M NaOH were added to the tubes to stop the reaction. The mixtures were centrifuged at 12,000 g for 10 minutes and absorbance of supernatant determined at 400 nm with a spectrophotometer. Phosphatase activity, expressed as μg of p-nitrophenol produced per g of soil per hour, was determined by comparing absorbance values to a standard curve prepared with reagent grade p-nitrophenol.

All soil dehydrogenase and phosphatase activities were measured in triplicate and the mean values compared with that of the control (unexposed) soil and results expressed as a percent of the control.

Soil nitrifying bacteria were enumerated by a micro-technique for most-probable-number (MPN) analysis (Rowe and Waide 1977) using media described by Alexander and Clark (1965). Ammonium-calcium carbonate medium for *Nitrosomonas*-type microorganisms consisted of $(\text{NH}_4)_2\text{SO}_4$, 0.5 g; K_2HPO_4 , 1.0 g; $\text{FeSO}_4 \cdot 7\text{H}_2\text{O}$, 0.03 g; NaCl , 0.3 g; $\text{MgSO}_4 \cdot 7\text{H}_2\text{O}$, 0.3 g; and CaCO_3 , 7.5 g in 1000 mL distilled water. Nitrite-calcium carbonate medium for *Nitrobacter*-type microorganisms consisted of KNO_2 , 0.006 g; K_2HPO_4 , 1.0 g; $\text{FeSO}_4 \cdot 7\text{H}_2\text{O}$, 0.03 g; NaCl , 0.3 g; $\text{MgSO}_4 \cdot 7\text{H}_2\text{O}$, 0.1 g; CaCl_2 , 0.3 g; and CaCO_3 , 1.0 g in 1000 mL distilled water. The media were autoclaved at 121°C with 15 lb pressure for 30 min. Aliquots (0.4 mL) were transferred to 30 mini-tubes. A 10-fold serial dilution of soil was prepared with sterile 0.85% saline solution. Five tubes were inoculated with 0.1 mL of 10^{-1} through 10^{-6} dilutions with five replicates at each dilution. After incubation for 6 weeks at room temperature in the dark, tubes containing ammonium-calcium carbonate medium for *Nitrosomonas* were tested for the presence of nitrite and/or nitrate using the modified Griess-Illosvay and nitrate spot test reagents described by Schmidt and Belser (1982). Positive tests for nitrite/nitrate in these tubes indicated the presence of *Nitrosomonas*. Tubes containing nitrite-calcium carbonate medium were tested for nitrite. A negative test for nitrite indicated the presence of *Nitrobacter*. Populations of both groups of nitrifying bacteria were calculated using a most-probable-number table (Alexander 1982) and presented as the log 10 of MPN per g of dry soil.

2.9 SOIL INVERTEBRATE ASSAY

An earthworm (*Eisenia fetida*) bioassay system was used to elucidate the toxicity of the HC smoke constituents. An artificial soil containing 350 g sand, 100 g Kaolin, and 50 g dried peat moss (adjusted to pH 6.5 with CaCO_3) was employed both for culture and for the earthworm exposures. Worms were fed twice weekly with fermented alfalfa, and soil moisture adjusted to 35% of dry weight. Exposure tests used 80 g of the artificial soil (placed in 100 x 25 mm Petri plates) containing five mature worms. Three replicate plates were used for each test series as noted in the text. The tests were terminated after 14 days, and effects observed over this period. Effects scored included earthworm mortality and simple response to physical stimulus (touching). Mass loading or dose was determined on similar soil plates without worms.

3.0 RESULTS AND DISCUSSION

3.1 SMOKE (AEROSOL) CHARACTERIZATION

Aerosol mass concentration was determined by mass and by specific chemical constituent for mixed-smoke obscurant aerosols. These data were then used to determine dose terms specific to each major component of the smokes during the wind tunnel tests. Size distributions of the airborne particles were determined and compared with type of obscurant, obscurant mixture, and aerosol concentration. Finally, deposition velocities of mixed-smoke aerosols to suspended surrogate surfaces were determined to provide data for comparison with deposition rates to the plant, soil, and water test surfaces.

3.1.1 Aerosol Mass Concentration

Mixed-smoke tests consisted of one, two, or three segments, each segment being the period of generation of a specific smoke. The sequence of generation was HC, then FO, and finally WP. Although most tests included all three smokes, two tests each were performed with FO only, HC and FO, and FO and WP. The average aerosol mass concentration present in the wind tunnel was determined for each test using the results of a laser transmissometer. In addition, the aerosol mass concentration present during individual portions of each test was determined. Test intervals are listed in Table 3.1, and average aerosol mass concentrations are shown in Table 3.2. Concentrations were close to the target levels of 600 mg/m³ (HC and FO) and 2000 mg/m³ (WP).

Actual aerosol concentration histories for mixed-smoke tests are shown in Figures 3.1 through 3.3. The peak seen in Figure 3.1 at about 10:00 during test MS-7 was due to an early generation of a large WP cup. This occurred because of a faulty water bath control valve. Figure 3.2 shows the FO/WP tests; the wind tunnel test section was isolated and purged of smoke between the two portions of these tests to exchange plant and soil samples. This procedure was required to obtain FO samples not contaminated with WP residue. Figure 3.3 shows the HC/FO tests; again, the wind tunnel test section was isolated between the two portions of the tests.

TABLE 3.1. INTERVALS OF HC, FO, AND WP AS THE PRIMARY COMPONENTS OF GENERATED AEROSOLS DURING MIXED-SMOKE OBSCURANT TESTS

Test	~Hexachloroethane		~Fog Oil		~White Phosphorus	
	Start/Stop (hr)	Δt (min)	Start/Stop (hr)	Δt (min)	Start/Stop (hr)	Δt (min)
<u>Range-Finding/Wind Speed</u>						
MS-3	8:20-9:25	65	9:25-10:40	75	10:40-11:52	72
MS-4	8:15-9:20	65	9:20-10:35	75	10:35-11:45	70
MS-5	8:30-9:35	65	9:35-10:50	75	10:50-12:00	70
MS-6	8:00-9:05	65	9:05-10:20	75	10:20-11:30	70
<u>Cumulative Dose</u>						
MS-7(a)	7:48-10:10	142	10:10-12:30	140	12:30-14:45	135
MS-8	7:53-10:10	137	10:10-12:30	140	12:30-14:45	135
MS-9	7:47-10:10	143	10:10-12:30	140	12:30-14:50	140
MS-10	7:47-10:10	143	10:10-12:32	142	12:32-14:40	128
MS-13(FO)	8:20-12:55	275				
MS-14	7:55-10:10	135	10:20-12:38	138		
MS-15	8:25-10:40	135	10:50-13:05	135		
MS-16	7:47-10:07	140	10:15-12:37	142		
MS-17	7:47-10:07	140	10:15-12:39	144		

(a) WP generated during a portion of the first third of test MS-07 (1 pot).

TABLE 3.2. AVERAGE ACTUAL AEROSOL MASS CONCENTRATION (CM) DURING EACH INTERVAL OF MIXED-SMOKE OBSCURANT TESTS (± 1 STD)

Test	Wind Speed (m/s)	~HC	~FO	~WP	Test Avg.
		CM (mg/m ³)	CM (mg/m ³)	CM (mg/m ³)	C ¹ (mg/m ³)
<u>Range-Finding/Wind Speed</u>					
MS-3	0.92	520 \pm 50	600 \pm 30	1760 \pm 520	970
MS-4	1.83	520 \pm 80	640 \pm 20	1640 \pm 450	940
MS-5	2.73	460 \pm 80	620 \pm 20	1740 \pm 550	940
MS-6	4.57	450 \pm 60	550 \pm 30	1450 \pm 390	820
<u>Cumulative Dose</u>					
MS-7(a)	1.79	860 \pm 660	570 \pm 250	1950 \pm 400	1120
MS-8	1.81	480 \pm 130	420 \pm 40	2320 \pm 480	1060
MS-9	1.78	520 \pm 40	680 \pm 70	2140 \pm 1030	1110
MS-10	1.77	520 \pm 40	700 \pm 80	2050 \pm 680	1060
MS-13(FO)	1.78		260 \pm 220		260
MS-14	1.75		550 \pm 180	2360 \pm 650	1460
MS-15	1.82		570 \pm 200	2140 \pm 490	1360
MS-16	1.78	540 \pm 50	640 \pm 80		590
MS-17	1.70	530 \pm 40	600 \pm 70		570

(a) WP generated during a portion of the first third of test MS-07 (1 pot).

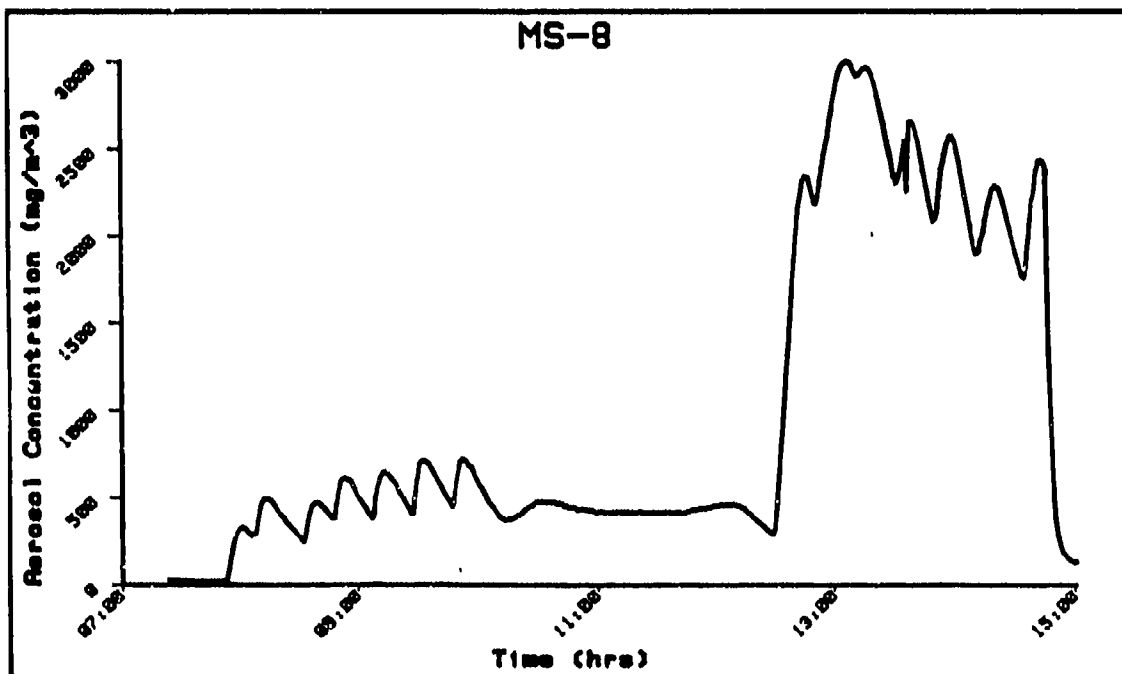
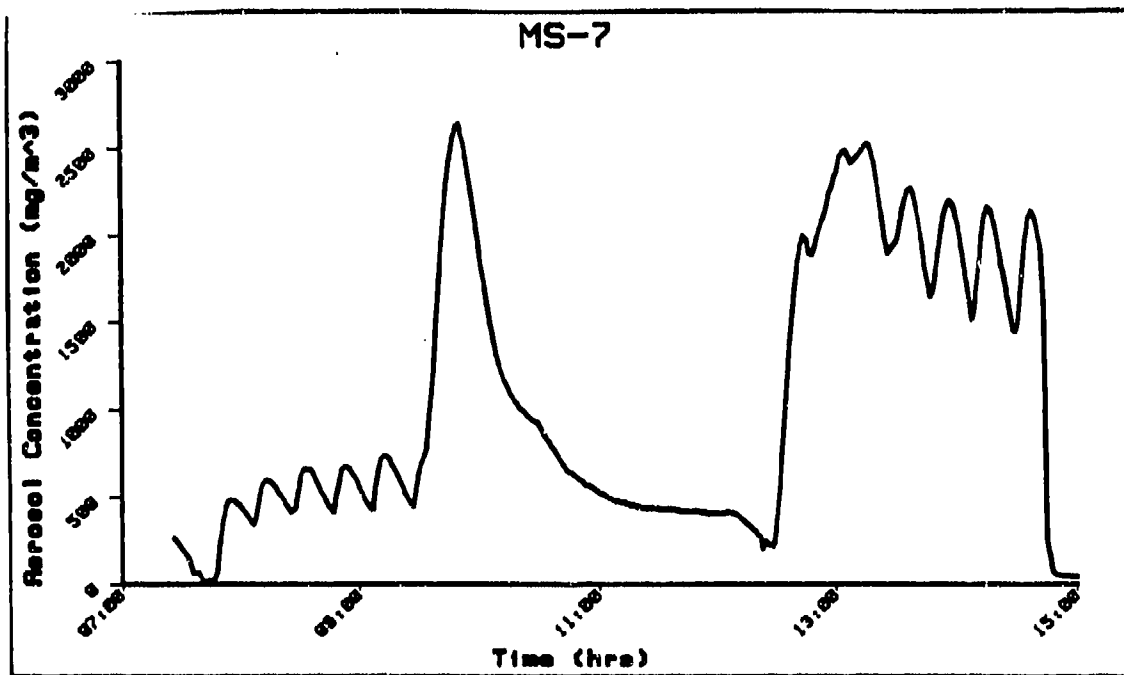

FIGURE 3.1. AEROSOL MASS CONCENTRATION DURING TESTS MS-7 AND MS-8 (CUMULATIVE DOSE SERIES--HC GENERATION DURING FIRST THIRD, FO DURING SECOND THIRD, AND WP DURING FINAL THIRD.) THE LARGE PEAK AT ~10:00 DURING TEST MS-7 WAS BECAUSE OF EARLY GENERATION OF ONE LARGE WP CUP.

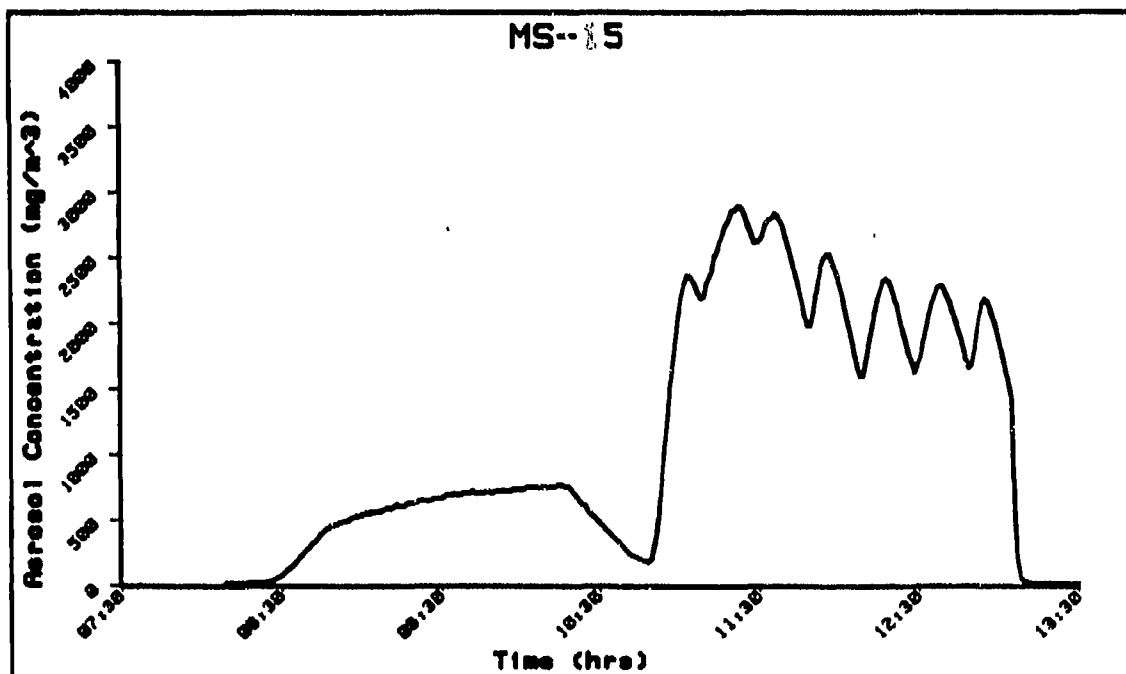
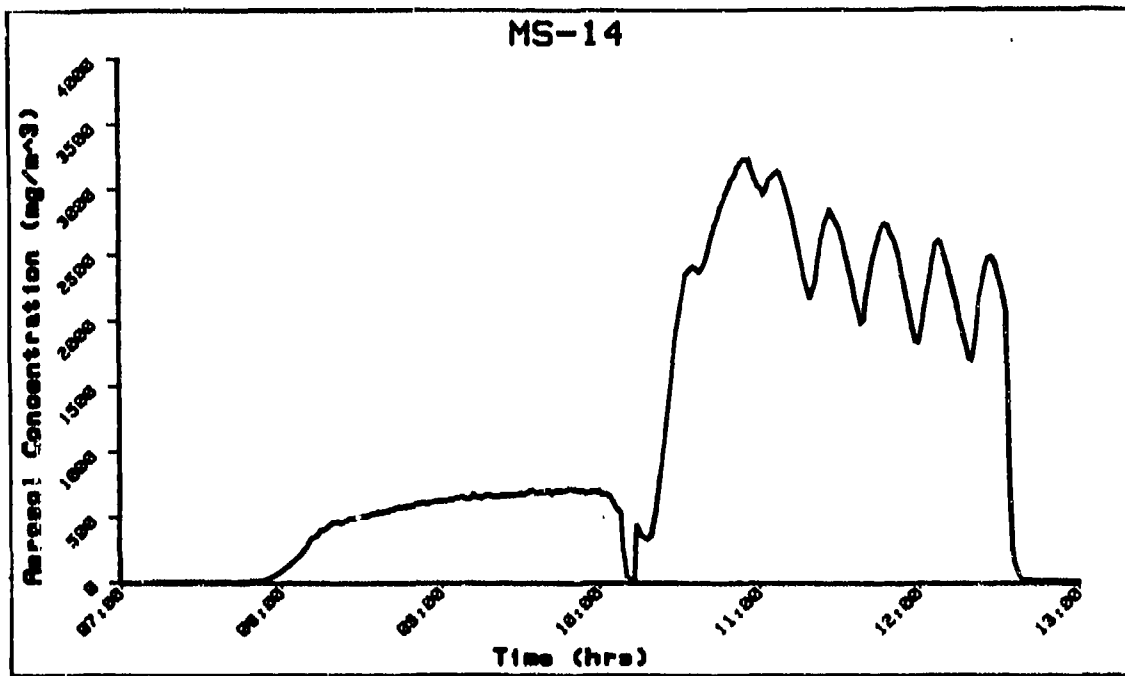

FIGURE 3.2. AEROSOL MASS CONCENTRATION DURING TESTS MS-14 AND MS-15 (CUMULATIVE DOSE SERIES--FO GENERATION DURING FIRST HALF, WP GENERATION DURING LAST HALF.) THE WIND TUNNEL TEST WAS ISOLATED BETWEEN THE TWO PORTIONS OF THESE TESTS TO EXCHANGE PLANT AND SOIL SAMPLES.

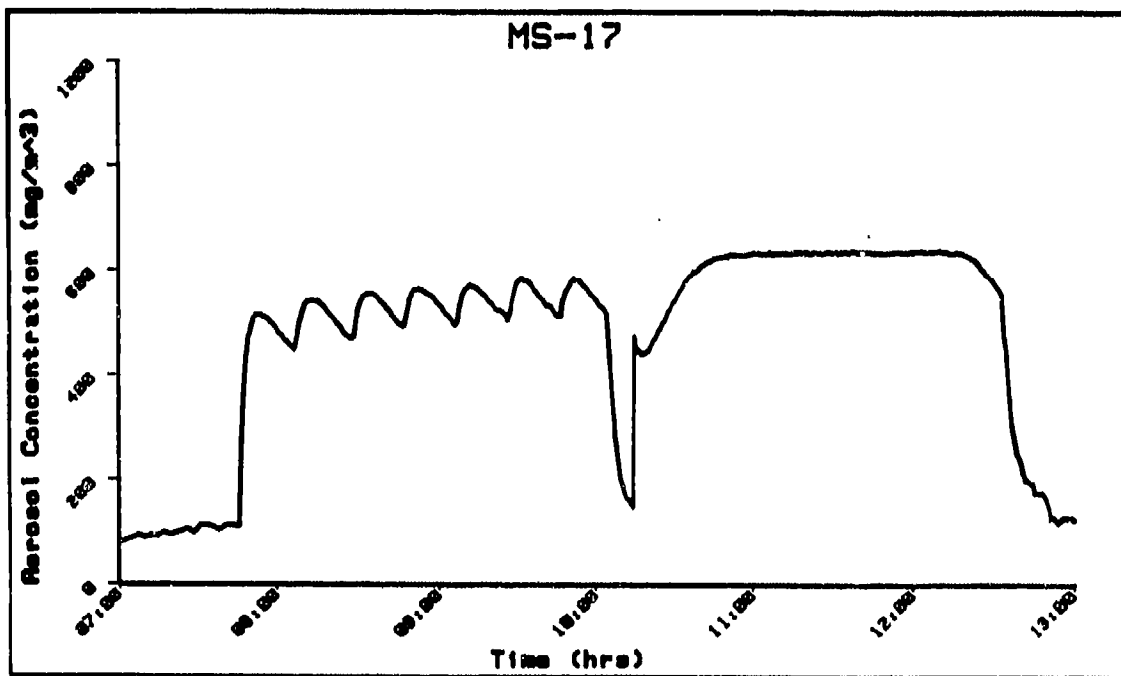
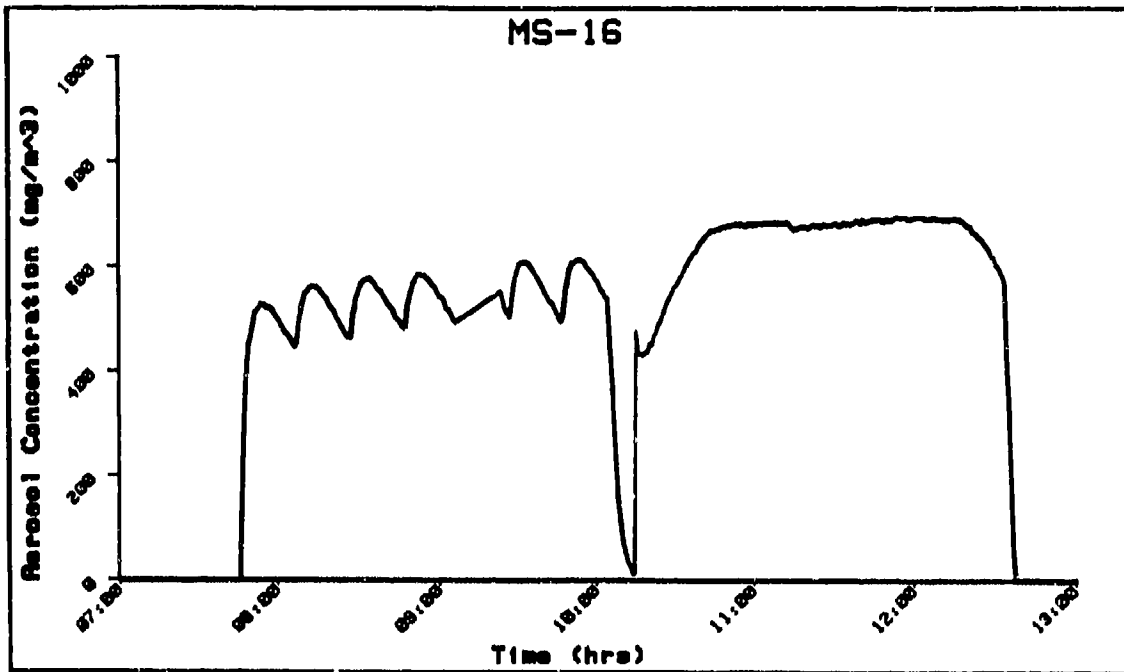

FIGURE 3.3. AEROSOL MASS CONCENTRATION DURING TESTS MS-16 AND MS-17 (CUMULATIVE DOSE SERIES--HC GENERATION DURING FIRST HALF, FO GENERATION DURING LAST HALF.) THE WIND TUNNEL TEST SECTION WAS ISOLATED BETWEEN THE TWO PORTIONS OF THESE TESTS TO EXCHANGE PLANT AND SOIL SAMPLES.

3.1.2 Mixed-Smoke Composition

The quantity of residual HC present during the FO segment and the residual HC and FO present during the WP segment of tests were determined subsequent to the determination of aerosol mass concentration. This was done using results of chemical analyses of filter coupons and calculation of dissipation rates of specific aerosols from the wind tunnel. Aerosol-specific mass concentrations were then determined. These are shown in Table 3.3. Because HC was typically present, as the primary aerosol and then as a residual aerosol for the entire duration of most tests, the exposure duration for HC shown in Table 3.3 was most often the sum of the durations of all three portions of the tests. Similarly, the durations of the FO portions were usually a combination of the FO and WP portions, and of the WP portions were equal to the duration of the third portion only. Tests MS-13 through MS-17 are exceptions in that they did not include all three aerosols. Test MS-7 is also an exception because of an inadvertent generation of a large WP mass at the end of the HC portion of the test. During that test, the WP bath water in one WP cup was lowered as the result of a failed bath water control valve, and then the mass was ignited when contacted by flaming ash from the combustion of the last HC pot.

TABLE 3.3. AVERAGE AEROSOL-SPECIFIC AEROSOL MASS CONCENTRATION (CM) DURING EACH INTERVAL OF MIXED-SMOKE OBSCURANT TESTS

Test	Hexachloroethane		Fog Oil		White Phosphorus	
	Duration (min)	CM (mg/m ³)	Duration (min)	CM (mg/m ³)	Duration (min)	CM (mg/m ³)
<u>Range-Finding/Wind Speed</u>						
MS-3	212	320	147	260	72	1390
MS-4	210	330	145	280	70	1240
MS-5	210	300	145	280	70	1360
MS-6	210	280	145	240	70	1100
<u>Cumulative Dose</u>						
MS-7 ^(a)	417	270	275	110	~300	~1110
MS-8	412	270	275	110	135	2180
MS-9	423	270	280	300	140	1940
MS-10	413	280	270	320	128	1840
MS-13(FO)	-	-	275	260	-	-
MS-14	-	-	273	340	138	2240
MS-15	-	-	270	360	135	1990
MS-16	282	330	142	520	-	-
MS-17	284	320	144	480	-	-

^(a) One large WP mass was inadvertently generated early during a portion of the first third of test MS-07. Average results were based on non-linear concentration estimates and mass of material generated relative to test MS-8. Results were similar to a 135-min concentration of 2460 mg/m³. The ratio of WF mass generated in MS-7 to that used in MS-8 was 1.23. The ratio of 2460 to 2180 was 1.13. The difference between these two ratios was speculated to be equal to the additional WP.

Because most plant, soil, and microbiological effects studies were performed by comparing effects with measured levels of deposited Zn, hydrocarbons, and/or P, the next step in the analysis of the applied dose (in the wind tunnel) for these components was to determine the concentration of each of these components during each test. Table 3.4 lists these data and information on the moisture content of the aerosols. Water, Zn, and P content of these aerosols were determined from samples collected when only HC was present, or at the end of the tests, when the aerosol was > ~90% WP. Although some variations were seen between the various test series, the dried fraction of the HC aerosols was $62.4 \pm 4.3\%$, and of the WP aerosols was $71.8 \pm 1.7\%$. The dried fraction of the FO aerosols was not measured, but was assumed to be approximately equal to the $99.0 \pm 2.0\%$ reported previously under similar test conditions (Cataldo et al. 1989a). The Zn fraction of fresh HC aerosols was seen to be $22.5 \pm 1.5\%$, and the P fraction of WP aerosols was $22.9 \pm 0.7\%$. These data agreed well with results of previous experiments (Van Voris et al. 1987; Cataldo et al. 1989b). Data reported for WP were corrected for residual HC and FO; for the samples considered, these residuals did not exceed 11% of the concentration of WP aerosol.

TABLE 3.4. AVERAGE CHEMICAL-SPECIFIC AEROSOL, DESICCATED, AND COMPONENT MASS CONCENTRATIONS (CM) DURING EACH INTERVAL OF MIXED-SMOKE OBSCURANT TESTS. FOG OIL MASS CONCENTRATION APPROXIMATELY EQUALED BY HYDROCARBON CONCENTRATION

Test	Hexachloroethane CM (mg/m ³)				Fog Oil CM (mg/m ³)		White Phosphorus CM (mg/m ³)			
	(min)	Mass	Dried	Zn	(min)	Mass	(min)	Mass	Dried	P
Range-Finding/Wind Speed										
MS-3	212	320	205	74	147	260	72	1390	1000	320
MS-4	210	330	210	77	145	280	70	1240	890	280
MS-5	210	300	195	70	145	280	70	1360	980	310
MS-6	210	280	180	65	145	240	70	1100	790	250
Cumulative Dose										
MS-7(a)	417	270	160	60	275	110	~300	~1110	~800	~250
MS-8	412	270	160	60	275	110	135	2180	1560	490
MS-9	423	270	160	60	280	300	140	1940	1390	440
MS-10	413	280	170	62	270	320	128	1840	1320	420
MS-13(FO)	-	-	-	-	275	260	-	-	-	-
MS-14	-	-	-	-	273	340	138	2240	1600	520
MS-15	-	-	-	-	270	360	135	1990	1420	460
MS-16	282	330	210	74	142	520	-	-	-	-
MS-17	284	320	200	72	144	480	-	-	-	-

(a) One large WP mass was inadvertently generated early during a portion of the first third of test MS-07. Average results were based on non-linear concentration estimates and mass of material generated relative to test MS-8. Results were similar to a 135-min concentration of 2460 mg/m³. The ratio of WP mass generated in MS-7 to that used in MS-8 was 1.23. The ratio of 2460 to 2180 was 1.13. The difference between these two ratios was speculated to be equal to the additional WP.

One method used to characterize the chemical composition of aerosols present during all phases of mixed-smoke tests used gravimetric and chemical analyses of isokinetic filter samples. These data are summarized in Table 3.5. The primary aerosol (HC, FO, or WP) was compared with Zn, Cl⁻, Al, P, H₂O, and "other" fractional constituents. The difference between the sum of all constituents and 100% was calculated and labeled as other. Water was measured as the differential mass present on filter samples after 24 h desiccation over drierite compared with fresh masses measured immediately post-sampling. Water was seen to vary from 25 to 40% of the fresh mass during the HC portion, from 7 to 18% during the FO portion, and from 20 to 27% during the WP portion of the tests. The fact that the water content did not decrease to about <5% during the FO portion of the tests may be attributed to the presence of residual HC aerosol throughout the FO portions. Mass represented by the other column is thought to include ash and chlorohydrocarbon species (for HC), hydrocarbon species (for FO), and oxygen and hydrogen components of polyphosphate compounds (for WP).

TABLE 3.5. CHEMICAL COMPOSITION OF MIXED-SMOKE AEROSOLS DURING SPECIFIC INTERVALS OF SEVERAL MIXED-SMOKE OBSCURANT TESTS. (ANALYSES OF ISOKINETIC AEROSOL FILTER SAMPLES)

Test	Sample ID No.	Fresh Mass (mg)	Smoke	Constituent by Mass Percentage					
				Zn (%)	Cl (%)	Al (%)	P (%)	H ₂ O (%)	Other(a) (%)
Range-Finding/Wind Speed									
MS-3	F2	2.62	HC	21.5	25.1	0.3	0.1	32.4	20.6
	F4	2.91	HC	21.9	24.4	0.3	0.0	36.1	17.3
	F6	3.14	HC/FO	13.1	15.8	0.1	0.0	25.2	45.8
	F8	2.99	FO	8.7	10.1	0.1	0.1	14.4	33.3
	F10	9.44	WP	1.2	0.3	0.0	18.1	26.1	55.3
	F12	11.25	WP	0.6	0.2	0.0	19.8	25.3	55.1
MS-4	F2	2.54	HC	22.5	25.4	0.4	0.1	39.4	12.2
	F4	2.99	HC	ND	ND	ND	ND	38.1	ND
	F6	3.29	HC/FO	12.9	14.7	0.2	0.1	21.6	50.5
	F8	3.06	FO	8.6	9.7	0.1	0.0	12.1	69.5
	F10	9.61	WP	1.3	0.2	0.0	19.2	ND	ND
	F12	10.02	WP	0.6	0.4	0.0	20.4	26.7	51.9
MS-5	F2	3.24	HC	24.5	29.5	0.5	0.1	35.8	9.6
	F4	4.04	HC	22.3	27.1	0.4	0.1	26.7	23.4
	F6	5.08	HC/FO	13.1	14.9	0.2	0.0	18.1	53.7
	F8	4.48	FO	8.1	9.1	0.1	0.0	15.0	67.7
	F10	16.11	WP	1.1	0.3	0.0	20.8	23.3	54.7
	F12	14.53	WP	0.6	0.1	0.0	21.3	23.3	54.7
MS-6	F2	5.83	HC	25.0	27.9	0.6	0.1	34.6	11.8
	F4	6.58	HC	24.4	27.5	0.5	0.1	35.7	11.8
	F6	6.83	HC/FO	14.3	16.7	0.3	0.0	25.0	43.7
	F8	7.17	FO	8.5	9.6	0.2	0.0	11.6	70.1
	F10	23.08	WP	1.1	0.1	0.0	19.8	23.0	56.0
	F12	24.65	WP	0.6	0.0	0.0	20.8	25.6	53.0
Cumulative Dose									
MS-16	F3	5.02	HC	23.1	27.5	0.8	-	37.5	11.1
	F5	5.74	HC	20.4	23.3	0.6	-	40.4	15.3
	F8	6.86	FO	5.7	6.9	0.1	-	8.7	78.6
MS-17	F3	5.16	HC	22.3	27.0	0.7	-	34.7	15.3
	F5	5.13	HC	23.6	25.5	0.5	-	37.0	13.4
	F8	6.34	FO	5.5	6.3	0.1	-	7.7	80.4
Final Test									
MS-2	F4	2.55	HC	24.0	29.6	0.4	0.7	25.9	19.4
	F8	3.29	FO	5.0	5.6	0.1	0.0	11.9	77.4
	F12	13.28	WP	0.5	0.0	0.0	21.2	20.3	58.0

(a) Includes ash and chlorohydrocarbon species (for HC), hydrocarbon species (for FO), and oxygen and hydrogen component of polyphosphate compounds (for WP).

3.1.3 Particle Size Distribution

Particle size distributions of the mixed-smoke aerosols were typically log-normal in distribution. Aerodynamic mass median diameters (AMMD) and geometric standard deviations (GSD) of the aerosols, measured during the mid to late stages of each segment of most tests, are shown in Table 3.6. Plots of selected particle size distributions are shown on logarithmic-probability graph paper in Figures 3.4 and 3.5. Ten samples were obtained of both HC and WP aerosols, and 15 of FO aerosols. Replicate samples of FO aerosols were obtained within 15 min of each other during two tests; the repeatability of measured AMMD was $\pm 0.03 \mu\text{m}$. Standard deviations of about 10% ($\sim 0.18 \mu\text{m}$) in AMMDs measured for each type of smoke throughout the mixed-smoke tests were primarily caused by a shift in the measured particle size between early (wind speed) and later (cumulative dose) tests. Consideration of sampling technique and aerosol and test conditions provided no insight on the particle size shift; however, the small magnitude of the shift (about 15%) should affect particle transport minimally, with deposition rates expected to be less during the cumulative dose tests by perhaps 1.2 to 1.5 times, a small change compared with the level of variability of the plant and soil deposition measurements and the range of deposition velocities measured to exposed surfaces.

TABLE 3.6. AEROSOL PARTICLE SIZE DISTRIBUTION RESULTS FOR MIXED-SMOKE TESTS

Test	Smoke	Wind Speed (m/s)	Rel. Hum. (%)	CM ^(a) (mg/m ³)	AMMD (μm)	GSD (-)
MS-1	FO ^a	0.9	42	800	1.91	1.73
	FO ^b			900	1.93	1.72
	WP			2000	2.34	1.67
MS-2	HC	0.9	59	480	1.63	1.58
	FO			600	1.69	1.68
	WP			2400	2.29	1.66
MS-3	HC	0.9	53	550	1.80	1.83
	FO			620	1.71	1.77
MS-4	HC	1.8	55	550	1.71	1.54
	FO ^(a)			640	1.65	1.77
	FO ^(b)			620	1.62	1.80
	WP			1950	2.26	1.63
MS-5	HC	2.7	49	470	1.78	1.67
	FO			630	1.68	1.77
	WP			2190	2.32	1.74
MS-6	HC	4.6	52	480	1.72	1.57
	FO			530	1.70	1.74
	WP			1800	2.40	1.67
MS-7	No Data	1.8	52			
MS-8	HC	1.8	52	580	1.38	1.54
	FO			280	1.22	1.98
	WP			2200	1.90	1.59

TABLE 3.6 . (Continued)

MS-FOT1	No Data	1.8	50			
MS-9	HC	1.8	52	540	1.43	1.85
	FO			650	1.47	1.66
	WP			2050	1.84	1.74
MS-10	HC	1.8	52	520	1.50	1.60
	FO			700	1.50	1.64
	WP			2300	1.88	1.70
MS-13	No Data	1.8	47			
MS-14	FO	1.8	52	680	1.56	1.96
	WP			2500	1.96	1.68
MS-15	FO	1.8	51	600	1.51	1.71
	WP			2270	1.92	1.62
MS-16	HC	1.8	54	620	1.55	1.59
	FO			620	1.57	1.87
MS-17	HC	1.7	52	550	1.53	1.58
	FO			600	1.56	1.73

Statistics:

Smoke	AMMD			GSD		
	AVG (μm)	± 1 STD DEV. ^(b) (μm)	STD DEV./AVG (%)	GSD (-)	± 1 STD DEV. ^(b) (-)	STD DEV./AVG (-)
HC	1.60	0.15	9.2	1.64	0.11	7.0
FO	1.59	0.16	10.3	1.77	0.11	6.0
WP	2.11	0.23	10.8	1.67	0.05	2.9

^(a) Aerosol mass concentrations (CM) approximate: ~ CM at time of sample.

^(b) Number of particle size distribution samples: 10 (HC), 15 (FO), and 10 (WP).

STD DEV. = Standard deviation.

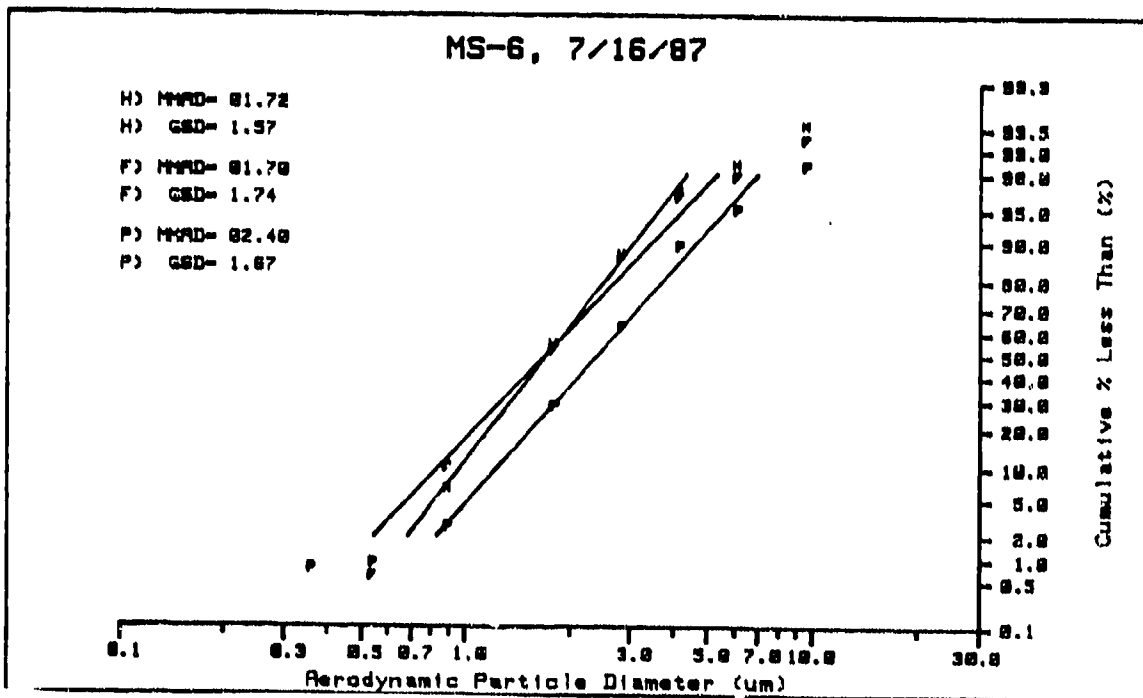
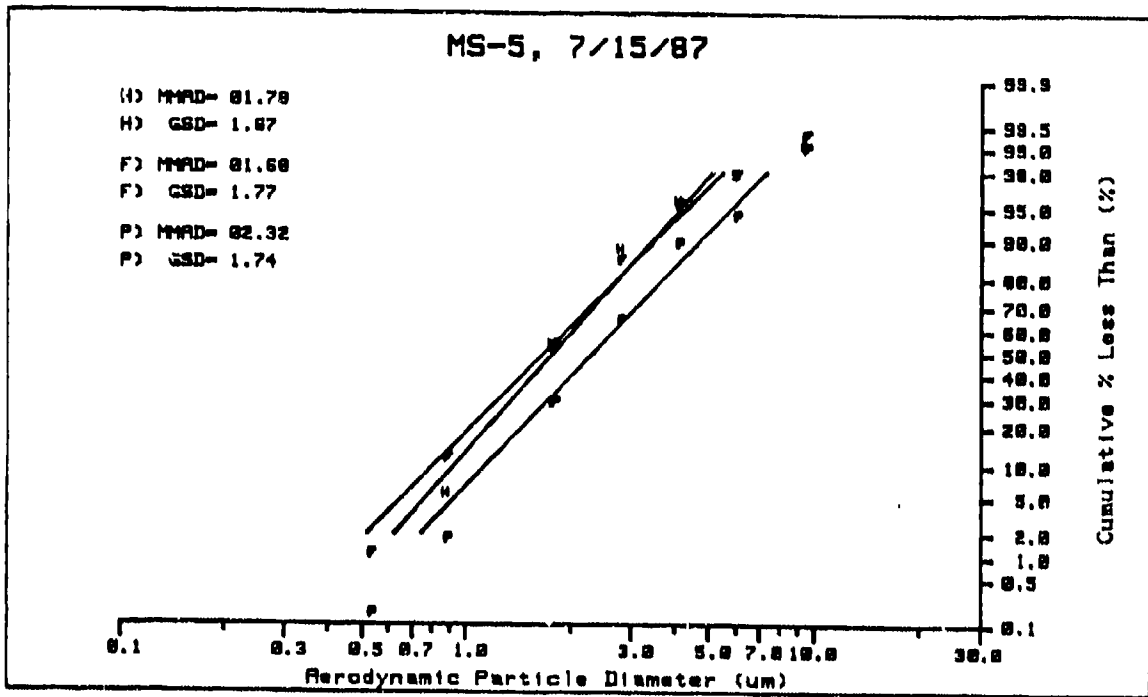

FIGURE 3.4. AEROSOL PARTICLE SIZE DISTRIBUTIONS FOR HC, FO, AND WP COMPONENTS OF TWO MIXED-SMOKE WIND SPEED EXPOSURE SERIES TESTS: MS-5 (2.73 m/s) AND MS-6 (54.57 m/s)

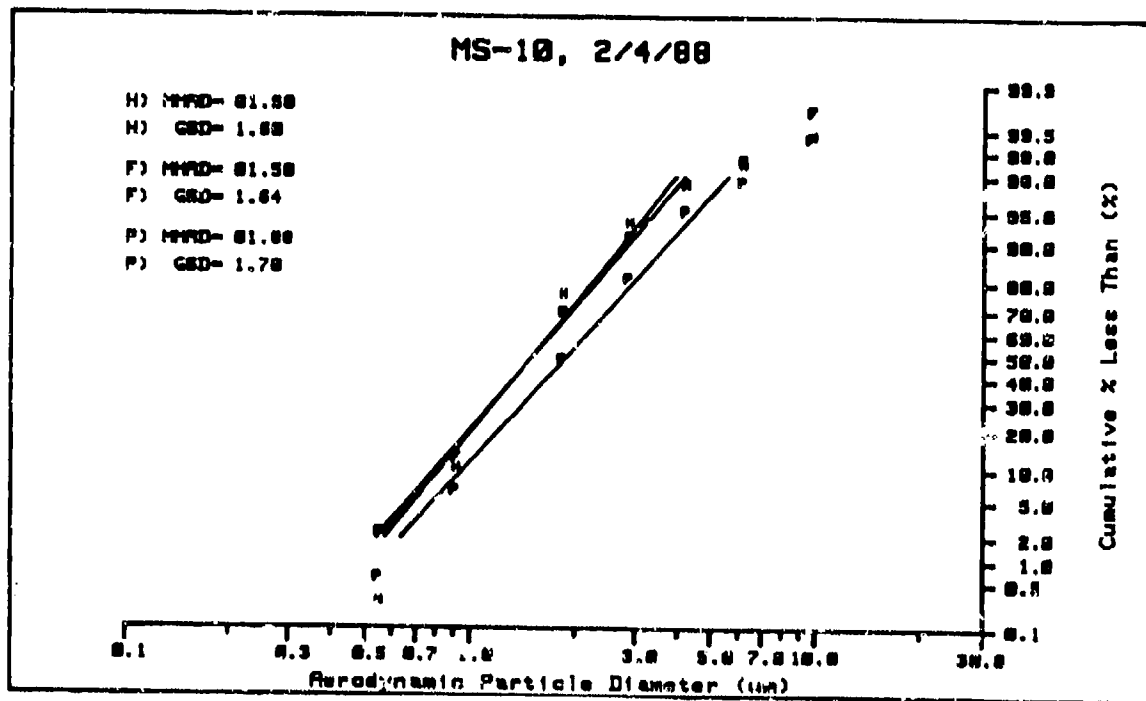
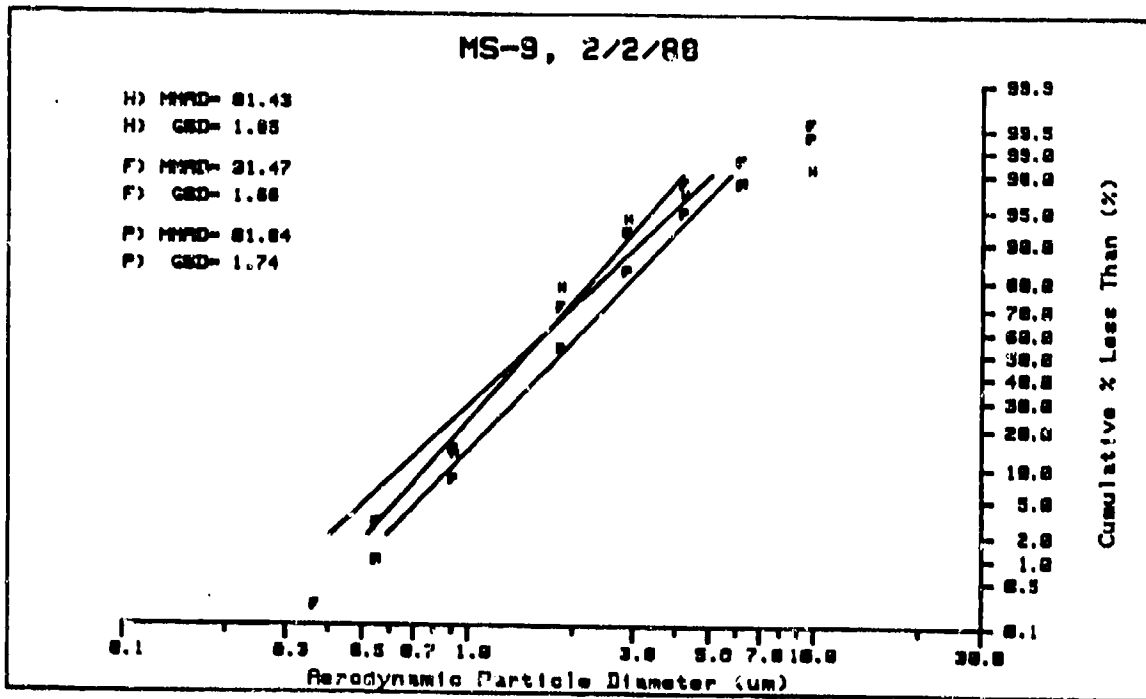

FIGURE 3.5. AEROSOL PARTICLE SIZE DISTRIBUTIONS FOR HC, FO, AND WP COMPONENTS OF TWO MIXED-SMOKE CUMULATIVE DOSE EXPOSURE SERIES TESTS: MS-9 AND MS-10

Although no obvious changes in particle size distribution occurred with changing wind speed (0.9-4.6 m/s) and relative humidity (42-59%), the AMMD of WP were consistently 1.3 times greater than those of HC and FO because of the increased concentration of WP in the wind tunnel. The increased particle size of the WP was attributed to a faster rate of smoke droplet coagulation, which was driven by the relatively greater concentration of WP (about 3.3 times greater than that of HC and FO). In addition, the AMMD of FO increased from about 1.2 to 1.5 μm to ~1.9 μm as aerosol concentration increased from 300 to 800 mg/m^3 . Although both HC and WP are hygroscopic, and increases in both concentration and particle size would be expected as a result of increased water vapor absorption as relative humidity increases, the limited range of humidities in the current study precluded this phenomena. Additional information on the influence of test environment on particle size distributions for RP/BR and WP, FO, and HC are discussed in Van Voris et al. (1987), Cataldo et al. (1989a and 1989b).

During each test, increased concentration and aerosol age promoted the growth of particles by coagulation. An opposite phenomena, the settling of large droplets onto the floor of the wind tunnel, occurring with increasing aerosol age, also influenced the aerosol particle size distribution. However, because of the small GSDs of each smoke, very large particles ($D_p > \sim 5 - 7 \mu\text{m}$) were not present in great quantity ($< 2 - 5\%$, by mass), and preferential settling of large particles was not a major influence on the evolving particle size distributions.

The aerodynamic size distributions of the mixed smoke aerosols were measured during these experiments to provide information suitable for the goal of characterizing the transport and effects of obscurant smoke aerosols. As an alternative measure of particle size, count median diameters (CMD) of the smoke droplets may be calculated from the measured aerodynamic MMD and the GSD. Based on average values (Table 3.6), and assuming droplet specific gravities (S.G.) of 0.8 (FO) and 1.8 (HC and WP), the typical count median diameter of the mixed smoke aerosols was calculated using the Hatch-Choate conversion equation (Hinds 1982). Results of this analysis

$$\text{CMD} = [(\text{AMMD}) + (\text{S.G.})^{1/2}] + (e^{3 \ln 2} \text{GSD}),$$

indicate average aerosol CMDs of 0.57 (HC), 0.63 (FO), and 0.71 μm (WP) were present in the wind tunnel during mixed smoke tests. Count median diameters represent the actual diameters of the median size of the spherical smoke droplets. Thus, CMD represents the particle size for which equal numbers of particles in the aerosol exist having smaller and larger diameters than the CMD. CMD is a more useful size parameter for comparing optical characteristics of aerosols, but MMD or AMMD are preferable for comparing transport, deposition, and ecological effect characteristics of aerosols.

3.1.4 Deposition Velocity to Suspended Surrogate Surfaces

Deposition velocities were measured for dried particulate mass, Zn, hydrocarbons, and P to glass fiber filter (GFF) coupons. Calculations included information listed in Table 3.4 and mass loading measurements from deposition coupons. Results are shown in Table 3.7 and in Figures 3.6 and 3.7. The coupons were positioned in the wind tunnel test section upwind of the plant specimens, and suspended horizontally via two coiled springs, as described in Section 2.4.4. In general, greater rates of deposition were observed with increasing wind speed; dried particulate mass deposited at a rate increasing 6.4 times from 0.0089 to 0.0571 cm/s as wind speed increased 5 times from 0.92 to 4.57 m/s (2 to 10 mph). An even greater increase was likely masked by resuspension of particulate matter, especially of the ash component of HC, as wind speed increased. Deposition was primarily to the top surface and leading edge of the coupons; the amount depositing to the lower surface was visually estimated to be less than $5 \pm 5\%$ of the total mass deposited. These deposition patterns suggested that impaction at the 0.042-cm-thick leading edge provided an important deposition phenomena, but that sedimentation of particles in the boundary layer over the top surface of the coupons supplied the greatest fraction of deposited material.

TABLE 3.7. DEPOSITION VELOCITIES TO SUSPENDED GLASS FIBER FILTER (GFF) COUPONS DURING MIXED-SMOKES TESTS

Test	Wind Speed (m/s)	Particulate Mass (cm/s)	Zinc (cm/s)	Hydrocarbon/FO (cm/s)	Phosphorus (cm/s)
MS-3	0.92	0.0089 ± 0.0010	0.0027 ± 0.0002	0.018 ± 0.009	0.0047 ± 0.0002
MS-4	1.83	0.013 ± 0.004	0.0037 ± 0.0012	0.013 ± 0.001	0.0069 ± 0.0022
MS-5	2.73	0.019 ± 0.002	0.0060 ± 0.0001	0.032 ± 0.003	0.012 ± 0.000
MS-6	4.57	0.057 ± 0.009	0.022 ± 0.000	0.054 ± 0.004	0.039 ± 0.000
MS-7-10	1.79		0.0034 ± 0.0004		0.0063 ± 0.0005
MS-14-15	1.78			0.028 ± 0.004	0.0056 ± 0.0002
MS-16-17	1.74		0.0037 ± 0.0001		
MS-7-17	1.78	0.010 ± 0.001			

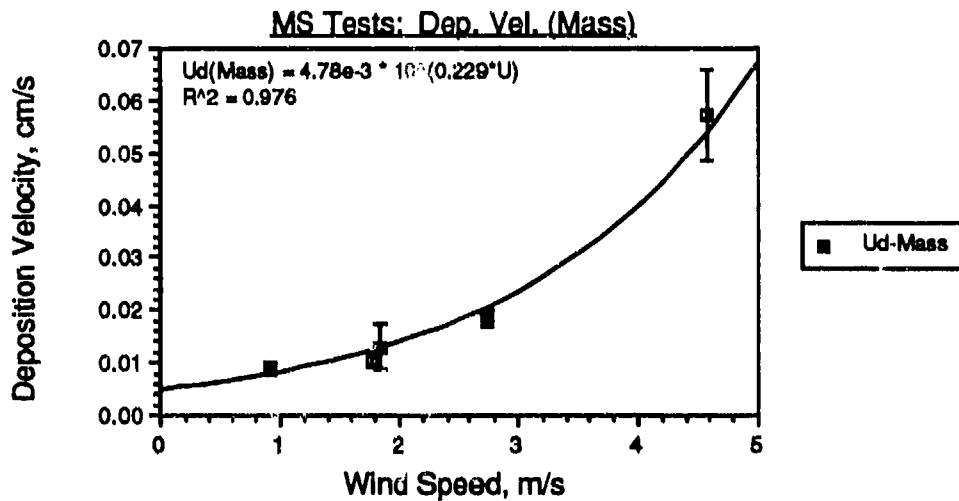

FIGURE 3.6. DEPOSITION VELOCITIES (V_d) TO HORIZONTALLY SUSPENDED 47-MM-DIA GLASS FIBER DEPOSITION COUPONS. U_d DETERMINED BY DESICCATED MASS COLLECTED ON BOTH SIDES (TOTAL AREA = CM^2) OF THE COUPONS, TOTAL TEST DURATION, AND AVERAGE AEROSOL MASS CONCENTRATION

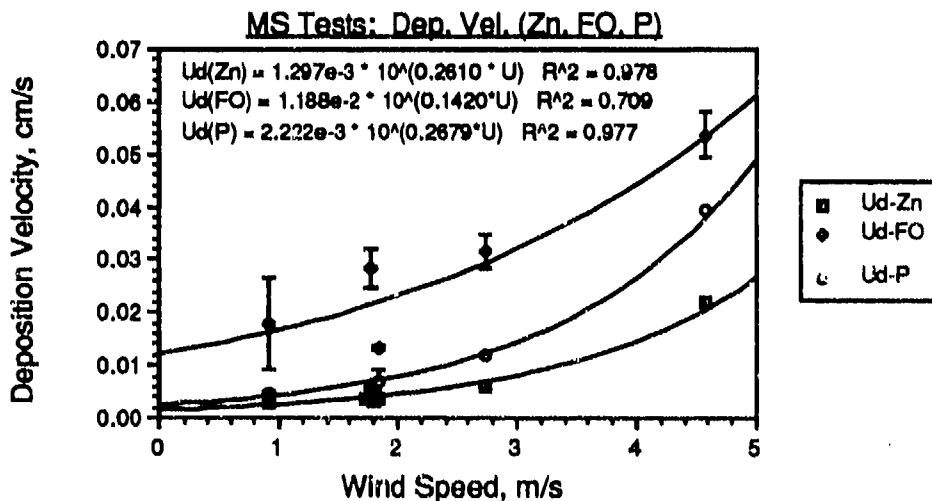

FIGURE 3.7. DEPOSITION VELOCITIES (V_d) OF COMPONENTS OF MIXED-SMOKE AEROSOLS TO HORIZONTALLY SUSPENDED 47 MM DIA GLASS FIBER DEPOSITION COUPONS. U_d DETERMINED BY Zn, HYDROCARBON (FO), AND P MASSES COLLECTED ON BOTH SIDES (TOTAL AREA = 34CM^2) OF THE COUPONS, AND DURATION AND AVERAGE AEROSOL MASS CONCENTRATION DURING SPECIFIC PORTIONS OF MIXED-SMOKE TESTS

Data for the determination of the deposition velocities of the major components of the smokes were based, typically on 2, but as many as 5 samples contacted with 0.1 N HNO₃ or iso-octane post-test. Deposition rates were calculated using test duration and aerosol concentration data listed in Table 3.4. Only the portions of the tests including each of the specific components were considered in these deposition rate calculations. For example, HC was usually present as a primary or residual aerosol throughout the duration of most tests, and WP was only present during the final portion of most tests. That FO deposition velocities were greater than those of HC and WP was due to the greater percentage (near 100%) composition of the hydrocarbon portion of FO compared with the Zn and P components of HC and WP, and to the tendency of FO deposits to spread and form a film, thus providing less potential for subsequent resuspension. Deposition velocities to suspended GFF coupons for specific smoke components, averaged over entire duration of individual tests, may be calculated by multiplying the listed deposition velocities (Table 3.7) by the square of the ratio of the duration listed for each specific component to the total test duration (listed in Tables 3.3 and 3.4). For example, the test-averaged deposition velocities of Zn would equal those listed in Table 3.7 because both durations are equal; however, the test-averaged deposition velocity for FO in test MS-3 would be $0.018 \times (147/212)^2 = 0.0087$ cm/s.

3.1.5 Quantification of Relative Applied Doses

Having determined the duration, average mass concentration, and deposition velocity to uniform surrogate surfaces (Sections 3.1.1-3.1.4) for each mixed smoke test, relative dose terms were calculated. The dose term is useful because aerosol concentration and chemical composition were not constant over test durations because of the nature of the mixture of three types of obscurants and the sequential process of generation that was employed to simulate actual training site conditions. The dose term describes the predicted loading, in mg/cm², of each major component of the mixed-smoke aerosols to suspended deposition coupons, and is calculated as the product of the specific duration, average mass concentration, and deposition velocity. The values of these parameters are listed in Table 3.7. Table 3.8 lists dose terms for mixed-smoke tests. These results provide a point of comparison for measured deposition velocities and ecological effects for other test subjects.

TABLE 3.8. CALCULATED RELATIVE DOSE TERMS, IN mg/m², FOR MAJOR COMPONENTS OF MIXED-SMOKE AEROSOLS

Test	Zinc (mg/cm ²)	Hydrocarbons (mg/cm ²)	Phosphorus (mg/cm ²)
MS-3	25	410	65
MS-4	36	320	81
MS-5	53	780	160
MS-6	180	1130	410
MS-7	51	370 ^(a)	285
MS-8	50	370 ^(a)	250
MS-9	52	1030 ^(a)	235
MS-10	52	1060 ^(a)	205
MS-13	-	880	-
MS-14	-	1560	240
MS-15	-	1630	210
MS-16	46	910 ^(a)	-
MS-17	45	850 ^(a)	-

^(a) FO deposition velocity data were not obtained during all tests at 1.8 m/s. FO Ud for tests MS-7, MS-17 was estimated to be 0.020 ± 0.008 cm/s, the average of other measurements at ~1.8 m/s.

3.2 CHEMICAL CHARACTERISTICS OF MIXED SMOKES

3.2.1 Organic Characterization of Aerosols

Characterization of organic residues associated with HC smokes was not performed in conjunction with mixed smoke tests. Details for organic constituents can be found in Cataldo et al. (1989b).

3.2.2 Inorganic Characterization of Aerosols

Aerosol Mass Filters

Analysis of the inorganic chemical constituents of aerosol filter leachates is presented in Table 3.9 and summarized in Table 3.10. Masses listed are as fresh weight, although most filters were desiccated 24 h before leaching for inorganic analysis; an exception was the test series MS-7-10, where filters were immediately contacted with leachate after fresh weight determination, so no moisture determination was made. Blank filter contribution is subtracted before tabulation. Because the order of aerosol generation is HC, then FO, followed by WP,

observed decline in Zn, Cl⁻, and Al contribution during phases II and III of the generation sequence represents deposition and dilution. The Cl/Zn ratio holds steady through HC and FO generation. Recall that, for earlier HC cumulative dose tests (Cataldo et al. 1989b), the Cl/Zn ratios averaged 1.14-1.17 for aerosol filters. The high percent P as phosphate in tests MS-2-6 results from the delay before contact with the extracting solution, because these filters were desiccated for 24 h before dissolution of the soluble aerosol components. Filters from MS-7-15 were contacted with leachate fairly soon after fresh weight determination, and so should more closely reflect fresh phosphate levels. Early studies with RP and WP deposition had shown complete conversion to phosphate when in the dry state for 24 h before addition of leachate water (see Table 3.14, Van Voris et al. 1987), so the presence of any non-phosphate P after that interval was not expected.

TABLE 3.9. ANALYSIS OF INORGANIC CHEMICAL CONSTITUENTS OF MIXED-SMOKE AEROSOL FILTER LEACHATES

Test	Sample	Mass ^(a) (mg total)	% PO ₄ -P				Cl/Zn Ratio	% Moisture	% Other	
			% Zn	% Cl	% Al	% P /P _{tot}				
MS-2	F2	2.54	23.22	28.15	0.44	0.12	NA	1.21		
MS-2	F3	2.44	22.50	28.43	0.00	0.03	NA	1.17		
MS-2	F4	2.55	24.03	29.61	0.42	0.73	NA	1.23	25.9	19.3
MS-2	F7	3.2	9.53	11.59	0.00	0.00	NA	1.22		
MS-2	F8	3.29	5.04	5.59	0.07	0.00	NA	1.11	11.9	77.4
MS-2	F10	12.17	1.01	0.18	0.03	19.87	99.1	0.18		
MS-2	F11	12.79	0.70	0.04	0.01	21.58	95.9	0.06		
MS-2	F12	13.28	0.49	0.02	0.01	21.23	100.9	0.05	20.3	57.9
MS-3	F2	2.62	21.52	25.07	0.33	0.08	NA	1.17	32.4	20.6
MS-3	F4	2.91	22.54	25.03	0.27	0.00	NA	1.11	36.1	16.1
MS-3	F8	3.14	13.05	15.83	0.12	0.04	NA	1.21	25.2	45.7
MS-3	F8	2.99	8.69	10.14	0.09	0.06	NA	1.17	14.4	66.6
MS-3	F10	9.44	1.25	0.26	0.02	18.11	92.2	0.21	26.1	54.3
MS-3	F12	11.25	0.56	0.16	0.01	19.82	86.9	0.29	25.3	54.1
MS-4	F2	2.54	22.47	25.35	0.39	0.07	NA	1.13	39.4	12.3
MS-4	F6	3.29	12.94	14.73	0.17	0.09	NA	1.14	21.6	50.5
MS-4	F8	3.06	8.65	9.70	0.09	0.00	NA	1.12	12.1	69.5
MS-4	F10	9.61	1.27	0.16	0.01	19.15	93.2	0.12	nd	
MS-4	F12	10.02	0.65	0.35	0.01	20.36	84.1	0.54	26.7	51.9
MS-5	F2	3.24	24.50	29.54	0.54	0.07	NA	1.21	35.8	9.6
MS-5	F4	4.04	22.30	27.10	0.40	0.07	NA	1.22	26.7	23.4
MS-5	F8	5.08	13.11	14.92	0.17	0.00	NA	1.14	18.1	53.7
MS-5	F8	4.48	8.14	9.13	0.11	0.02	NA	1.12	15	67.6
MS-5	F10	16.11	1.13	0.27	0.02	20.61	77.9	0.23	23.3	54.7
MS-5	F12	14.53	0.65	0.05	0.00	21.27	92.4	0.07	23.3	54.7

TABLE 3.9. (Cont.)

Test	Sample	Mass ^(a)				% PO ₄ -P		Cl/Zn Ratio	% Moisture	% Other
		(mg total)	% Zn	% Cl	% Al	% P	/P _{tot}			
MS-6	F2	5.83	24.99	27.87	0.55	0.09	NA	1.12	34.6	11.9
MS-6	F4	6.58	24.42	27.50	0.50	0.05	NA	1.13	35.7	11.8
MS-6	F6	6.63	14.27	16.67	0.28	0.03	NA	1.17	25	43.8
MS-6	F8	7.17	8.46	9.65	0.16	0.00	NA	1.14	11.6	70.1
MS-6	F10	23.08	1.10	0.14	0.01	19.76	101.9	0.13	23	56.0
MS-6	F12	24.65	0.61	0.02	0.01	20.77	101.8	0.03	25.6	53.0
MS-7	F3	4.42	19.74	22.71	0.54	0.07	NA	1.15		
MS-7	F5	4.26	19.94	22.27	0.55	0.05	NA	1.12		
MS-7	F8	5.43	5.23	0.84	0.15	14.55	44.9	0.16		
MS-7	F15	31.14	0.02	0.06	0.00	21.45	56.8	2.48		
MS-7	F17	23.89	0.01	0.09	0.00	21.60	57.0	6.62		
MS-8	F3	6.23	22.93	26.40	0.41	0.10	NA	1.15		
MS-8	F5	6.77	21.84	25.82	0.80	0.01	NA	1.18		
MS-8	F8	4.72	12.07	12.97	0.33	0.00	NA	1.08		
MS-8	F17	28.11	0.03	0.07	0.00	20.85	58.1	2.82		
MS-9	F3	5.57	24.21	27.01	0.09	0.04	NA	1.12		
MS-9	F5	6.15	23.07	25.29	0.71	0.00	NA	1.10		
MS-9	F8	9.09	6.36	7.43	0.17	0.00	NA	1.17		
MS-9	F15	37.27	0.03	0.06	0.00	21.04	50.8	1.90		
MS-9	F17	24.99	0.01	0.08	0.00	21.25	51.0	5.37		
MS-10	F3	7.48	22.44	24.95	0.59	0.15	NA	1.11		
MS-10	F5	6.42	22.87	27.16	0.65	0.11	NA	1.19		
MS-10	F8	8.60	6.55	7.83	0.17	0.07	NA	1.19		
MS-10	F15	31.04	0.05	0.06	0.00	20.14	48.4	1.35		
MS-10	F17	26.51	0.01	0.04	0.00	20.67	57.8	4.43		
MS-14	F9	30.69	0.00	NA	0.02	21.28	33.5	NA		
MS-14	F11	24.02	0.00	NA	0.03	21.65	33.1	NA		
MS-14	F12	21.82	0.00	NA	0.03	22.46	31.8	NA		
MS-15	F9	28.54	0.00	NA	0.02	21.55	27.3	NA		
MS-15	F11	31.36	0.00	NA	0.02	22.54	30.6	NA		
MS-15	F12	20.41	0.00	NA	0.02	21.17	27.9	NA		
MS-16	F3	5.02	23.09	27.54	0.80	NA	NA	1.19	37.5	11.1
MS-16	F5	5.74	20.37	23.31	0.65	NA	NA	1.14	40.4	15.3
MS-16	F8	6.86	5.67	6.90	0.13	NA	NA	1.22	8.7	78.6
MS-17	F3	5.16	22.27	27.02	0.71	NA	NA	1.21	34.7	15.3
MS-17	F5	5.13	23.57	25.53	0.50	NA	NA	1.08	37	13.4
MS-17	F8	6.34	5.47	6.34	0.10	NA	NA	1.10	7.7	80.4

(a) Mass on a fresh weight basis.

(b) NA: not applicable because of one or more missing components.

TABLE 3.10. ANALYSIS OF INORGANIC CHEMICAL CONSTITUENTS OF MIXED-SMOKE AEROSOL FILTER LEACHATES. SUMMARIZED AVERAGES

Test	N	Function	Mass ^(a)				% PO ₄ -P		Cl/Zn Ratio
			(mg total)	% Zn	% Cl	% Al	% P	/P _{tot}	
MS-2-6 summary									
HC gen	11	AVERAGE	3.49	22.32	26.14	0.36	0.12		1.17
		STD DEV	1.43	3.27	3.78	0.17	0.20		0.05
FO gen	9	AVERAGE	4.35	9.87	11.35	0.13	0.02		1.15
		STD DEV	1.61	2.97	3.49	0.08	0.03		0.03
WP gen	11	AVERAGE	14.27	0.86	0.15	0.01	20.23	93.30	0.17
		STD DEV	5.18	0.30	0.11	0.01	1.03	7.79	0.15
MS-7-MS-10 summary (b)									
HC gen	8	AVERAGE	5.91	22.13	25.20	0.59	0.06		1.14
		STD DEV	1.11	1.56	1.84	0.10	0.05		0.03
WP gen	6	AVERAGE	30.60	0.03	0.07	0.00	21.01	54.74	3.31
		STD DEV	6.22	0.01	0.01	0.00	0.47	3.99	1.94
MS8-10 summary									
HC gen	6	AVERAGE	6.44	22.89	26.11	0.61	0.07		1.14
		STD DEV	0.64	0.79	0.90	0.11	0.06		0.04
FO gen	3	AVERAGE	7.47	8.33	9.41	0.22	0.02		1.15
		STD DEV	2.39	3.24	3.09	0.09	0.04		0.06
WP gen	6	AVERAGE	31.63	0.03	0.06	0.00	20.84	54.05	2.89
		STD DEV	6.62	0.01	0.01	0.00	0.40	4.48	1.66
MS14-15 summary									
WP gen	6	AVERAGE	26.14	0.00		0.02	21.77	30.70	
		STD DEV	4.68	0.00		0.01	0.59	2.61	
MS16-17 summary									
HC gen	4	AVERAGE	5.26	22.32	25.85	0.66			1.16
		STD DEV	0.32	1.41	1.90	0.13			0.06
FO gen	2	AVERAGE	6.80	5.57	6.62	0.11			1.19
		STD DEV	0.37	0.14	0.39	0.02			0.04

(a) Mass on a fresh weight basis.

(b) Test 7 had pre-scheduled ignition of WP pot, interfering with FO results.

Because Table 3.9 groups all unanalyzed components of the aerosol smokes as other, further explanation is warranted. In the case of HC smoke generation, this component would include any ash and chlorinated hydrocarbon products; for FO, this would include residual ash and chlorinated hydrocarbon products from the HC, plus (unburned) hydrocarbons from vaporization of the FO. For WP, the oxygen and hydrogen components of the resultant

polyphosphoric distribution are not directly analyzed, but may be approximated. The percent P in acid polyphosphates is 32.3% for 1P, and would approach 39.5% (also the value for cyclic metaphosphates) for infinite chain lengths. Because the desiccation process enhances the conversion of polyphosphates to phosphate (as borne out analytically in the percent P as phosphate after desiccation), it is reasonable to use 32.3% as the phosphorus component in the dried residual, even though that component may have been higher in the fresh weight. Note that the small increase in weight because of oxidation of the polyphosphates actually means the corresponding initial moisture content of the fresh aerosol was slightly higher. Subtracting the hydrogen and oxygen component from the other component value in the last filters from tests MS-2-6 results in an estimated 11.0% final residual component due primarily to FO, because the HC component at that time was negligible (Table 3.11).

TABLE 3.11. ESTIMATION OF FOG OIL COMPONENT IN THE AEROSOL BY CHEMICAL APPROXIMATIONS

Test	P (%)	Other (%)	O,H Component (%)	FO est. ^(a) (%)
MS-2	21.2	57.9	44.5	13.4
MS-3	18.1	54.3	38.0	16.3
MS-3	19.8	54.1	41.5	12.6
MS-4	20.4	51.9	42.7	9.3
MS-5	20.6	54.7	43.2	11.5
MS-5	21.3	54.7	44.6	10.2
MS-6	19.8	56.0	41.4	14.6
MS-6	20.8	53.0	43.5	9.5
LAST FILTERS OF EA. TEST ONLY:			Average	11.0
			Std dev.	1.9
			Count	5.0

(a) This column would contain any residual HC ash and chlorinated hydrocarbons, but these are minor components to the total mass at these sampling intervals.

Inorganic Chemical Analysis of Aqueous Impingers

Aqueous impingers containing 50 mL deionized water were collected during each of the three phases of aerosol generation during the MS tests (Table 3.12). Tests MS-1 and MS-2 were performed for determination of required test conditions for aerosol generation at the targeted concentrations, and are not necessarily similar to succeeding

TABLE 3.12. ANALYSIS OF INORGANIC CHEMICAL CONSTITUENTS OF MIXED-SMOKE AQUEOUS IMPINGERS. (A) MASS LOADING. (B) AVERAGE TRAPPING RATE OF ANALYTES

PART A:

Test	Sample	Elapsed Time (min)	Zn (mg)	Al (mg)	P (mg)	Cl (mg)
PART B:						
MS-1	IMPINGER 1	53	2.27	0.02	0.00	2.53
MS-2	IMPINGER 1	51	1.94	0.03	0.00	2.23
MS-3	IMPINGER 1	53	2.30	0.02	0.00	2.46
MS-4	IMPINGER 1	50	2.07	0.02	0.00	2.44
MS-5	IMPINGER 1	50	1.95	0.03	0.00	2.30
MS-6	IMPINGER 2	25	1.03	0.01	0.01	1.22
MS-1	IMPINGER 2	41	1.68	0.01	0.01	1.83
MS-2	IMPINGER 2	52	1.32	0.02	0.00	1.47
MS-4	IMPINGER 2	54	1.42	0.01	0.00	1.69
MS-5	IMPINGER 2	26	0.77	0.01	0.00	0.90
MS-6	IMPINGER 4	25	0.40	0.00	0.01	0.53
MS-1	IMPINGER 3	67	1.16	0.03	14.95	1.13
MS-2	IMPINGER 3	53	0.43	0.01	11.65	0.38
MS-4	IMPINGER 3	51	0.42	0.01	8.40	0.33
MS-5	IMPINGER 4	29	0.22	0.01	6.85	0.11
MS-6	IMPINGER 6	19	0.07	0.00	2.18	0.06
MS-3	IMPINGER 2+3	50 (a) 47 (a)	1.77	0.02	8.40	1.75

PART B:

Test	Sample	Zn (µg/min)	Al (µg/min)	P (µg/min)	Cl (µg/min)	%PO ₄ -P /P _{tot}	Cl/Zn Ratio
MS-1	IMPINGER 1	42.74	0.31	0.00	47.64		1.11
MS-2	IMPINGER 1	38.04	0.63	0.00	43.63		1.15
MS-3	IMPINGER 1	43.30	0.45	0.00	46.42		1.07
MS-4	IMPINGER 1	41.30	0.44	0.00	48.70		1.18
MS-5	IMPINGER 1	38.90	0.61	0.00	46.06		1.18
MS-6	IMPINGER 2	41.00	0.25	0.54	48.90		1.19
MS-1	IMPINGER 2	40.85	0.23	0.36	44.63		1.09
MS-2	IMPINGER 2	25.38	0.33	0.00	28.27		1.11
MS-3	IMPINGER 2	26.30	0.26	0.00	31.30		1.19
MS-4	IMPINGER 2	29.42	0.29	0.00	34.77		1.18
MS-5	IMPINGER 4	15.84	0.11	0.28	21.07		1.33

TABLE 3.12. (Contd.)

PART B: (Continued)

Test	Sample	Zn ($\mu\text{g}/\text{min}$)	Al ($\mu\text{g}/\text{min}$)	P ($\mu\text{g}/\text{min}$)	Cl ($\mu\text{g}/\text{min}$)	%PO ₄ -P /P _{tot}	Cl/Zn Ratio
MS-1	IMPINGER 3	17.31	0.48	223.13	16.79	43.7	0.97
MS-2	IMPINGER 3	8.20	0.25	219.81	7.08	40.3	0.86
MS-3	IMPINGER 3	8.23	0.18	164.71	6.50	29.8	0.79
MS-4	IMPINGER 4	7.55	0.22	236.21	3.92	34.2	0.52
MS-5	IMPINGER 6	3.66	0.16	114.47	3.05	26.7	0.83
MS-3	IMPINGER 2+3	18.20	0.24	178.72	17.99	31.1	0.99

(a) Total interval used for Zn, Cl, and Al deposition rate; only the 47-min interval used for P deposition rate.

tests. Other potential causes of data fluctuation include the integrity of the multiple glass-to-tubing vacuum system connections and resultant effect on actual sampling rate, and to the time of impinger collection relative to the intervals of each aerosol generation.

During test MS-3, the same trap solution was used as during the FO and WP generation phases, resulting in a mixed sample. These solutions were used for quantification of P only. For tests MS-3 through MS-6, the level of P as phosphate averaged $31 \pm 2\%$ of total P in those impingers taken during WP generation. The Cl/Zn ratio during HC and FO segments remained at 1.16 ± 0.07 ($N = 11$), or very near to the theoretical figure of 1.08 for ZnCl_2 . Earlier HC cumulative dose tests (Cataldo et al. 1989b) showed similar ranges for Cl/Zn ratios (1.12-1.15).

3.2.3 Mass Loading and Deposition Velocity to Receptor Surfaces

Deposition velocities were calculated for plant, soil, and surrogate surfaces located within the wind tunnel test section during the mixed-smoke tests. Surrogate deposition coupons were used to provide relatively uniform surfaces for aerosol deposition for comparison with plant and soil deposition. Surfaces used included suspended glass fiber filters, for simulation of deposition to a foliar canopy, and wet and dry polystyrene Petri plates, simulating surface soil deposition.

Deposition Filters

Deposition filters (47 mm glass fiber) were pre-acid-washed before exposure in the aerosol flow path using the spring technique (Cataldo et al. 1989b) for simulation of plant leaf exposures. Deposition filters collected during MS tests were desiccated for 24 h before mass determination unless otherwise noted, because previous experience has shown that true fresh weight determinations were unattainable because of moisture loss during exposure and before initial weighing. Analysis of eight filters exposed during test MS-2 for dried versus undried weights showed a ratio of 0.871 ± 0.013 , indicating that the differences were consistent. Because these filter analyses will be used for calculation of average deposition velocities for the mixed aerosol components, a comparison must be made based on dry weight of aerosol, rather than fresh weight.

Inorganic chemical analysis of deposition leachates is summarized in Table 3.13. Masses listed are on a desiccated weight basis for test series MS-2-6 and MS-16-17, and on an air-dried basis for test series MS-7-15. All filters were leached using 10 mL aliquots of 0.01 M HNO_3 , with the exception of aqueous extraction of test MS-2 filters DC2 and DC6. Blank filter contribution was subtracted from observed concentrations before final calculation. Because no difference was noted between acidic and aqueous leachate results, these results were included in the averages.

Filters contacted with leachate shortly after weighing (MS-7-15) show roughly half the available P as phosphate, implying that the breakdown of polyphosphates is slower in the presence of FO and HC+FO. Because these leachates demonstrate a significant potential for elevated polyphosphate composition relative to earlier studies of WP aerosols alone (Van Voris et al. 1987), stabilization by the other components in the mixed aerosol is suspected. The variation in percent P as phosphate found in leachates that began after desiccation (MS-2-6) was because the filters had been desiccated for a minimum of 24 h, but desiccation times actually ranged up to 1 week. When the $\% \text{PO}_4\text{-P}/\text{P}_{\text{tot}}$ is plotted versus time to water contact (Figure 3.8), the scatter-plot reveals about the same degree of confidence ($R^2=0.91$) by the exponential curve fit shown ($Y=48.02 \cdot 10^{(4.12 \cdot e^{-2 \cdot X})}$) or by a linear fit ($Y=47.05 + 6.313 \cdot X$). This was much slower than the essentially complete conversion of P to phosphate in about 24 h when only P smoke was generated (Van Voris et al. 1987). Hydrated

TABLE 3.13. INORGANIC CHEMICAL CONSTITUENTS OF MIXED-SMOKE DEPOSITION COUPON LEACHATES. (A) PERCENT DISTRIBUTION. (B) DEPOSITION VELOCITIES

PART A.

Test	n	Function	Mass (a) (mg total)	Mass (a) (mg/cm ²)	%Zn	%Cl	%Al	%P	% PO ₄ -P /P _{tot}
MS-2	4	AVERAGE	5.48	0.16	4.35	2.23	0.11	20.8	91.5
		STD DEV	0.81	0.02	0.16	0.75	0.04	0.6	1.3
MS-3	2	AVERAGE	3.61	0.10	6.56	4.52	0.08	19.1	61.0
MS-4	2	AVERAGE	6.00	0.17	5.52	3.57	0.08	14.7	61.1
MS-5	2	AVERAGE	7.96	0.23	6.28	3.39	0.10	21.0	56.8
MS-6	2	AVERAGE	20.11	0.58	8.49	2.53	0.20	22.1	68.9
MS-7	3	AVERAGE	13.41	0.39	3.24	2.26	0.12	18.8	49.7
		STD DEV	1.31	0.04	0.05	0.10	0.01	0.4	1.0
MS-8	3	AVERAGE	12.94	0.37	4.12	2.75	0.12	21.9	49.8
		STD DEV	4.06	0.12	0.46	0.42	0.01	0.5	1.0
MS-9	3	AVERAGE	10.96	0.32	3.77	2.52	0.11	19.0	45.0
		STD DEV	2.84	0.08	0.20	0.57	0.01	0.5	0.8
MS-10	3	AVERAGE	13.22	0.38	3.72	2.16	0.11	18.8	43.0
		STD DEV	0.99	0.03	0.12	0.31	0.01	0.4	0.3
MS-14	3	AVERAGE	12.83	0.37	NA	NA	NA	17.9	50.2
		STD DEV	0.72	0.02	(b)			0.3	1.1
MS-15	3	AVERAGE	12.22	0.35	NA	NA	NA	19.3	46.3
		STD DEV	0.83	0.02				0.1	1.4
MS-16	3	AVERAGE	3.95	0.11	10.14	14.75	0.28	NA	NA
		STD DEV	0.32	0.01	0.40	0.60	0.00		NA
MS-17	3	AVERAGE	4.58	0.13	10.73	14.84	0.24	NA	NA
		STD DEV	0.22	0.01	0.17	0.50	0.01		

PART B.

Test	n	Function	Zn ----- (µg/cm ²)	Cl ----- (µg/cm ²)	P	Cl/Zn Ratio	V _{d,as P}	V _{d,as Zn}	V _{d,as Cl}
							(10 ³ cm/s)		
MS-2	4	AVERAGE	6.9	3.1	32.9	0.51	ND	ND	ND
		STD DEV	0.9	0.9	5.5	0.16	(c)		
MS-3	2	AVERAGE	6.8	4.6	19.8	0.68	13.7	7.7	4.5
MS-4	2	AVERAGE	8.6	5.6	22.9	0.65	15.9	9.8	5.5

TABLE 13. (Contd.)

PART B. (Continued)

Test	n	Function	Zn	Cl	P	Cl/Zn Ratio	V _d as P (10 ³ cm/s)	V _d as Zn	V _d as Cl
			————— (μg/cm ²) —————						
MS-5	2	AVERAGE	14.4	7.8	48.3	0.54	31.5	16.3	7.3
MS-6	2	AVERAGE	49.1	14.2	128.2	0.29	103.9	56.4	14.5
MS-7	3	AVERAGE	12.5	8.7	72.9	0.70	15.0	9.3	5.7
		STD DEV	1.1	0.7	8.8	0.02	1.8	0.8	0.5
MS-8	3	AVERAGE	15.6	10.0	81.5	0.67	20.7	10.5	5.7
		STD DEV	6.5	1.9	23.9	0.13	6.1	4.3	1.1
MS-9	3	AVERAGE	11.9	7.7	60.2	0.67	15.8	7.4	4.3
		STD DEV	3.2	0.8	16.8	0.13	4.4	2.0	0.4
MS-10	3	AVERAGE	14.2	8.2	71.8	0.58	22.3	9.0	4.5
		STD DEV	1.5	0.5	6.3	0.10	1.9	0.9	0.3
MS-14	3	AVERAGE	NA	NA	66.1	NA	15.5	NA	NA
		STD DEV			3.8		0.9		
MS-15	3	AVERAGE	NA	NA	68.1	NA	18.1	NA	NA
		STD DEV			5.0		1.3		
MS-16	3	AVERAGE	11.6	16.8	NA	1.45	NA	9.5	11.8
		STD DEV	1.4	1.9		0.01		1.1	1.4
MS-17	3	AVERAGE	14.1	19.6	NA	1.38	NA	11.3	13.7
		STD DEV	0.7	0.9		0.03		0.6	0.7

- (a) Mass on a desiccated weight basis for tests MS-2-6, MS-16-17; mass on an air-dried (fresh) weight basis for test series MS-7-15.
 (b) NA: not applicable due to absence of at least one component.
 (c) ND: not determined, since only a preliminary test.

polyphosphates are thermodynamically unstable with respect to hydrogen phosphate in storage at room temperature, but kinetics is the controlling factor. Stabilization may be lower on the isokinetic aerosol filter samples simply because the concentration of the components in the aerosol from earlier smoke generation would have been greatly decreased before sampling, whereas the deposition coupons were exposed during all phases of aerosol generation, and consequently, would have deposition of the first two phases before

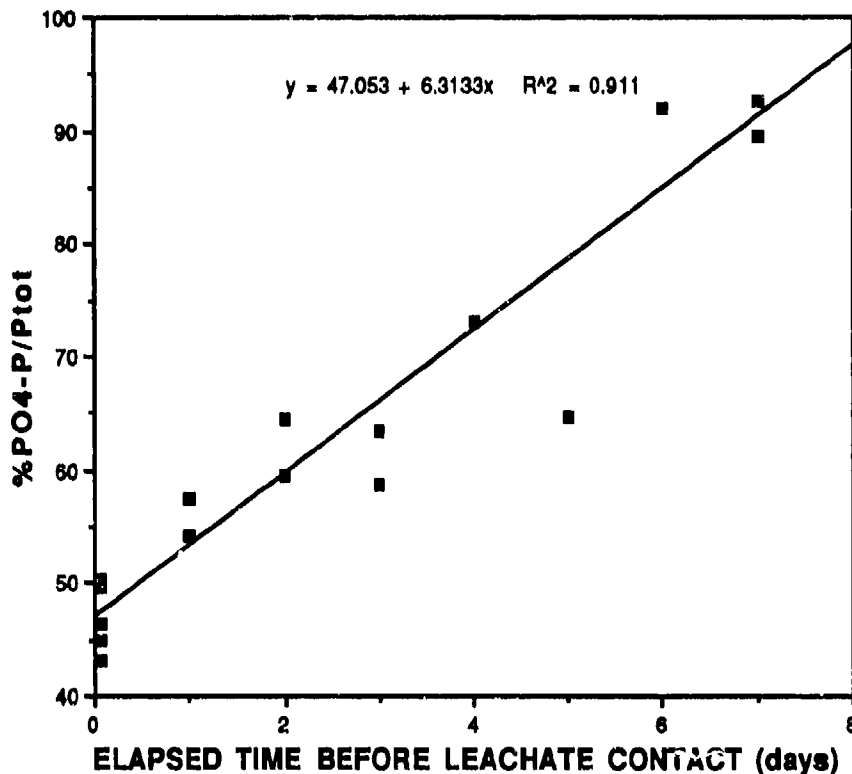

FIGURE 3.8. HYDROLYSIS OF POLYPHOSPHATES TO PHOSPHATE VERSUS TIME HELD IN THE DRY STATE

introduction of the WP aerosol. Complexation of metaphosphates with Zn^{+2} results in stability constants in the log K of 2-3 range; complexes of chain polyphosphates with transition metals are more stable than the corresponding cyclic metaphosphates.

In highly acidic solution, metallic cations inhibit hydrolysis, while in weakly acidic to weakly basic solutions, they can catalyze hydrolysis. For both linear and cyclic polyphosphates, metal ions generally have a greater catalytic effect on hydrolysis in alkaline than in acidic media. Minor pH variations can cause major effects on hydrolysis rate, depending on the metal cation under study. Because the aerosol particles are in contact with humid air, the resultant solution chemistry should be that of stronger acid solutions; thus, the Zn

complexation with higher polyphosphates may cause a slight increase in stabilization. Partial stabilization as complexes may explain the decrease in the hydrolysis rate of the higher polyphosphates.

Deposition on Wet and Dry Surfaces

Nominally 100-mm polystyrene Petri dish covers were used for collection of deposition onto wet (deionized water, Table 3.14) and dry (Table 3.15) surfaces during the mixed-smoke tests. For a few tests, selected dry deposition plates were exposed for only portions of the mixed smokes runs: for test series MS-7-8, plates DD-(A to D), DD-(1,2), and WD-(1,2) were exposed for the entire run interval, while plates DD-(3,4) were exposed during HC and FO generation only, and DD-(5,6) were exposed during WP generation only; for MS15, DD#0/1 plates were exposed only during WP generation; for MS16, DD#-1/0 plates were exposed only during HC generation. Again, no significant difference between aqueous and acidic dissolution of the deposited particulate was observed; so, results of both types were averaged together. Test MS-7 was a special case, because one WP pot malfunctioned and ignited during the latter part of the HC generation phase causing elevated P in the DD3 and DD4 leachates. The FO generation was below expected for tests MS-7 and MS-8, but that has not been correlated with any effect on the inorganic chemistries to date.

The ratio of wet to dry deposition Zn concentrations averaged 1.4 for test series MS-3-6 and MS-8-10. The loss of chloride from dry deposition is covered in the following section. Phosphorus generally showed similar deposition onto wet and dry plates for test series MS-3-6 and MS-8-10 (no wet surfaces exposed during test MS-7), with an average wet/dry ratio of 1.0 ± 0.1 . However, for test series MS-14-15, where HC smoke deposition was absent, the wet/dry ratio averaged 1.4, similar to earlier single-smoke WP and RP tests, having wet/dry ratio averaging 1.3 ± 0.1 (Van Voris et al. 1987). The percent of P as phosphate was consistently lower in the wet deposition samples compared to the dry deposition samples. However, the difference was smaller than observed with P aerosol alone. This is particularly interesting because the elapsed time between deposition and initial water contact to the dry deposition plates was generally longer during the MS tests than it had been during the WP tests, because of altered manpower. For example, during RFT-B2.1 (Van Voris et al. 1987), dry deposition plates resulted in 58% as phosphate (sample ID No. 10-84-371), while wet deposition plates

TABLE 3.14. MASS LOADING AND DEPOSITION VELOCITIES BASED ON MIXED-SMOKE DEPOSITION ONTO WET SURFACES

Test	N	Zn	Cl ($\mu\text{g}/\text{cm}^2$)	P	% PO ₄ -P /P _{tot}	Cl/Zn Ratio	V _d as P	V _d as Zn (10 ³ cm/s)	V _d as Cl
MS-1	2	15.5	34.0	59.4	42.1	2.19			
MS-2	2	18.8	44.1	66.9	40.0	2.34			
MS-3	2	18.6	24.8	40.7	32.2	1.33	33.6	25.3	28.9
MS-4	2	17.6	30.7	42.5	29.6	1.75	35.1	23.9	35.8
MS-5	2	14.7	42.5	50.2	32.4	2.90	39.1	19.7	47.3
MS-6	2	16.9	60.5	53.6	30.4	3.61	51.7	23.1	73.8
MS-8	2	25.2	45.7	115.2	31.6	1.84	29.2	16.7	26.2
MS-9	2	21.0	37.0	82.2	32.9	1.77	21.6	13.0	20.7
MS-10	2	21.6	39.5	97.4	32.6	1.82	30.4	13.8	21.8
MS-8-10	6	22.5 ±2.0	40.7 ±4.0	98.3 ±15.1	32.4 ±0.8	1.81 ±0.06	27.1 ±4.3	14.5 ±1.8	22.9 ±2.6
MS-8/OH(A)	2	23.8	53.8	115.6	31.4	2.28	29.3	15.8	30.9
MS-14	2	0.2	NA	132.8	31.0	NA	31.2	NA	NA
MS-15	2	0.1	NA	138.3	29.0	NA	36.7	NA	NA
MS-16	2	23.8	43.6	0.0	NA	1.85	NA	19.5	30.7
MS-17	2	22.6	38.8	0.0	NA	1.72	NA	18.1	27.1

(a) 0.01 M NaOH solution used for wet deposition.

(b) NA: not applicable because of absence of at least one component.

TABLE 3.15. MASS LOADING AND DEPOSITION VELOCITIES BASED ON MIXED-SMOKE DEPOSITION ONTO DRY SURFACES

Test	N	Extractant	Zn	Cl ($\mu\text{g}/\text{cm}^2$)	P	% PO ₄ -P /P _{tot}	Cl/Zn Ratio	V _d as P	V _d as Zn (10 ³ cm/s)	V _d as Cl
MS-1	2	H ₂ O	13.8	0.65	81.3	45.6	0.05			
MS-1	2	0.01 M HNO ₃	13.4	0.56	60.4	50.0	0.04			
MS-1	4	AVERAGE	13.6	0.60	60.9	47.9	0.04	ND(d)	ND	ND
		±STD DEV	0.3	0.16	0.9	2.6	0.01			
MS-2	2	H ₂ O	13.7	0.64	70.0	44.6	0.05			
MS-2	2	0.01 M HNO ₃	12.8	0.84	66.2	48.4	0.06			
MS-2	4	AVERAGE	13.2	0.74	68.0	46.5	0.06	ND	ND	ND
		±STD DEV	0.5	0.13	3.9	2.4	0.01			
MS-3	2	H ₂ O	13.2	0.56	39.6	35.4	0.04	30.6	16.8	0.6
MS-3	2	0.01 M HNO ₃	13.6	0.54	40.0	35.0	0.04	31.0	17.2	0.6
MS-3	4	AVERAGE	13.4	0.56	39.8	35.2	0.04	30.7	17.0	0.6
		±STD DEV	0.3	0.12	0.4	0.3	0.01	0.3	0.4	0.1
MS-4	2	AVERAGE	13.7	0.60	41.8	33.0	0.04	32.3	17.4	0.7
MS-5	2	AVERAGE	14.1	1.12	51.6	38.3	0.08	37.6	17.7	1.2
MS-6	2	AVERAGE	16.8	1.45	57.9	31.8	0.09	52.2	21.3	1.7
MS-7	2	H ₂ O	14.6	0.52	19.9	25.7	0.04	4.2	11.0	0.4
MS-7	2	.01 M HNO ₃	14.4	0.43	20.3	26.1	0.03	4.2	10.8	0.3
MS-7	4	AVERAGE	14.5	0.48	20.1	25.9	0.03	4.1	10.9	0.3
		±STD DEV	0.4	0.13	0.4	0.3	0.01	0.1	0.3	0.1
MS-8	2	.01 M HNO ₃	15.0	0.56	105.4	42.8	0.04	26.7	10.0	0.4
MS-9	2	.01 M HNO ₃	14.0	0.39	86.0	42.8	0.02	22.6	8.6	0.2
MS-10	2	.01 M HNO ₃	14.5	0.64	102.9	42.27	0.04	32.0	9.2	0.3
MS-8-10	6	AVERAGE	14.5	0.53	98.1	42.8	0.04	27.1	9.3	0.3
		±STD DEV	0.5	0.14	9.6	0.6	0.01	4.2	0.6	0.1
MS-7-1/0	2	.01 M HNO ₃	14.6	0.37	20.7	25.4	0.02	4.2	10.9	0.2
MS-8-1/0	2	.01 M HNO ₃	17.0	18.1	<.05	NA ^(a)	1.06	NA	11.4	10.4
MS-9-1/0	2	.01 M HNO ₃	14.9	17.1	<.05	NA	1.14	NA	9.2	9.6
MS-8-9-1/0	4	AVERAGE	15.9	17.6	<.05	NA	1.11	NA	10.3	10.0
		±STD DEV	1.4	1.43			0.06		1.3	0.9
MS-7-0/1	2	.01 M HNO ₃	0.10	0.09	84.0	44.8	0.88	23.3 ^(b)	0.1	0.1
MS-8-0/1	2	.01 M HNO ₃	0.18	0.24	115.0	52.2	1.40	29.2	0.1	0.1
MS-9-0/1	2	.01 M HNO ₃	0.18	0.21	92.7	52.2	1.14	24.4	0.1	0.1
MS-8-9-0/1	4	AVERAGE	0.15	0.18	97.2	49.8	1.14	25.6	0.1	0.1

TABLE 3.15. (Cont.)

Test	N	Extractant	Zn	Cl ($\mu\text{g}/\text{cm}^2$)	P	% PO ₄ -P /P _{tot}	Cl/Zn Ratio	V _d as P	V _d as Zn (10 ³ cm ² /sec)	V _d as Cl
		±STD DEV	0.04	0.07	14.3	3.9	0.24	2.8	0.0	0.0
MS-7	2	.01 M NaOH	1.44	0.31	19.7	25.2	0.22	4.1	1.1	0.2
MS-7	BLK	.01 M HNO ₃	<.005	0.07	<.1					
MS-7	BLK	.01 M NaOH	<.005	<.03	<.1					
MS-14	4	.01 M HNO ₃ ±STD DEV	0.12 0.07	NA	93.0 0.5	46.8 1.2	NA	21.8 0.1	NA	NA
MS-15	2	.01 M HNO ₃	0.09	NA	102.7	43.4	NA	27.2	NA	NA
MS-16	2	.01 M HNO ₃	14.2	15.6	NA	NA	1.10	NA	11.7	11.0
MS-17	2	.01 M HNO ₃	13.7	15.2	NA	NA	1.11	NA	11.0	10.6
MS-15-0/1	2	.01 M HNO ₃	0.16	NA	104.6	43.9	NA	27.7	NA	NA
MS-16-1/0	2	.01 M HNO ₃	11.4	12.8	NA	NA	1.12	NA	11.5 ^(c)	10.0 ^(c)

(a) Not applicable because component not present.

(b) Corrected to proper aerosol concentration and time for single-smoke exposure by estimations from test MS-8 concentrations.

(c) Corrected to proper aerosol concentration and time for single-smoke exposure.

(d) ND = Not determined.

averaged $30 \pm 1\%$ (sample ID Nos. 10-84-367 through 370). Similarly, for WP, dry deposition plates averaged 53% (N = 2) as phosphate (test WP-3, sample ID Nos. 3-85-297,298), while wet deposition plates (sample ID No. 10-84-299) resulted in 31% as phosphate. Although individual aerosol testing methods may not irreputably support the stabilization hypothesis, the compilation of different tests suggests that stabilization may be occurring.

A few tests with basic trapping solution (tests MS-7 and MS-8) yielded wet deposition results similar to the corresponding waters (test MS-8) for Zn and P, and 18% increases in trapped Cl⁻. For dry deposition leaching with base (test MS-7), Zn was not dissolved by the base, and Cl⁻ was low in both cases. This solubility pattern is not consistent with Zn combining with P as pyrophosphate in the dry state, for example, because a corresponding decrease in soluble P is not observed in the basic extraction. Formation of less-soluble Zn polyphosphates during particle aging on the dry deposition plates may result in hindering of the hydrolysis to phosphate; such species might then be less soluble under subsequent contact with dilute

NaOH. Test MS-7 was the only test that had pre-ignition of a WP pot during the latter part of HC generation, which may have some influence on the resultant dry deposition, because the phosphate percent of total P in all dry deposition plates from that study is below the range seen in other sequential mixed-smoke tests. This suggests that some stabilization of the higher polyphosphates, perhaps during co-deposition with Zn, or even because of interaction while still as an aerosol. No other tests were performed with comparable conditions to use for validation of any hypotheses.

Loss of Chloride from Dry Deposition Plates

The notable result emerging from the dry deposition surfaces is loss of Cl^- capture and analysis. If the Zn and Cl^- had been collected only as ZnCl_2 , the theoretical Cl/Zn ratio would be 1.085. Although wet deposition resulted in Cl/Zn mass ratios ranging from 1.7 to 3.6 for wet deposition samples (Table 3.14), Cl^- levels virtually disappear on dry deposition plates (Table 3.15). In contrast, for single-smoke HC cumulative dose test series A (low loading), wet/dry ratio was 1.3 for both Cl^- and Zn (N = 18 wet, 36 dry); for series B (higher loading), the ratio was 1.5 for both Cl^- and Zn (N = 18 wet, 35 dry) (Cataldo et al. 1989b). For both RP and WP tests, the wet/dry deposition ratio averaged 1.3 ± 0.1 (N = 18) versus P analysis (Van Voris et al. 1987). The effect is attributed to interaction of the dry chloride residuals with polyphosphates, because the dry deposition plates seeing only HC or HC + FO consistently yield Cl/Zn ratios of about 1.1, essentially the theoretical ratio for ZnCl_2 . Plates exposed to WP only appear to have similar Cl/Zn ratios, but the low concentrations coupled with the unsubtracted Cl^- blank (actually a combination of contamination in the acid plus an analytical system blank) make these ratios unreliable. For earlier HC cumulative dose tests (Cataldo et al. 1989b), the Cl/Zn ratios averaged 1.16-1.22 for wet deposition plates, 1.12-1.20 for dry deposition plates, and 1.37-1.21 for dry deposition onto glass fiber filters. Those plates exposed for HC and FO only showed Cl/Zn ratios similar to those for dry deposition in HC-only runs. For wet deposition, the Cl/Zn ratios vary widely for test to test but are always greater than the theoretical value. Wet deposition plates showed Cl/Zn ratios greatly exceeding those of HC-only runs.

For the mixed smokes aerosol filters (Table 3.9) taken during the HC and FO generation phases, the ratios range from 1.1-1.2 and are reasonably consistent within a test. During the WP generation phase, the chloride drops out much more rapidly than does Zn. For impingers (Table 3.12), the Cl/Zn ratio ranges from 1.11-1.18 during HC generation, remains roughly consistent during FO generation, and drops to 0.50-0.97 during WP generation. In contrast, deposition filters (Table 3.13) exhibit Cl/Zn ratios ranging from 0.3-0.7; wet deposition coupon Cl/Zn ratios are 1.3-3.6 (Table 3.14); dry deposition coupon Cl/Zn ratios are 0.04-0.09 (Table 3.15) when all three smoke components are present.

The great disparity in deposition values suggests that the available aerosol Cl^- is initially in a form deposited at the same rate as the aerosol particulate, but upon addition of the WP aerosol reacts to form either an insoluble component, a compound of Cl not as chloride, or a gaseous product. Phosphorus oxy-chloride anions can be produced during ring cleavage of metaphosphates by molten salts, but presence of any moisture would prohibit formation of such a product. Insolubility is doubtful, because the desiccated filters show essentially total conversion of polyphosphate to phosphate, which would have released any Cl if a chloro-polyphosphate compound had even been possible. The most logical hypothesis is the release of Cl as gaseous HCl as a result of polyphosphate hydrolytic degradation and neutralization, which would generate sufficient heat to drive off HCl from "dry" surfaces, but would remain in solution on wet surfaces. The HCl levels in the tunnel were not directly monitored during these tests, because early studies with HC-only aerosols showed minimal acid formation. The acidity of the WP aerosol would mask indirect detection of trace releases of HCl as increased acidity in those samples collected during the WP phase of the test.

Deposition to Soil Surfaces

Thin lens soil coupons were exposed as described in Section 2.5.2. Actual mass loading and deposition velocities as determined from dissolution into deionized water (Table 3.15) can be based only on phosphorus and chloride values, because of the sorption of Zn to varying degrees by the soils.

Fresh Palouse soils were exposed to two mass loadings: fresh Palouse 1 was at loadings similar to other soils exposed during test MS-3; fresh Palouse 2 had 50% of the mass loading of fresh Palouse 1, on a basis of grams soil exposed. Although this had little effect on the highly soluble P and Cl, it did affect the solubilized Zn concentrations. Accordingly, these soils are not averaged in Table 3.16.

Estimation of deposition on soil surfaces is based on wet (Table 3.14) and dry (Table 3.15) deposition plate data. Assuming similar deposition and total solubility, the expected concentrations in the 100-mL solution contacting soils exposed over areas of 165 cm^2 during test MS-3 were (wet; dry deposition):

Zn: 30.7 ppm; 22.1 ppm,
P: 67.2 ppm; 61.7 ppm, and
Cl: 40.9 ppm (based on wet only).

TABLE 3.16. MASS LOADING ON SOIL COUPONS, BASED ON AQUEOUS DISSOLUTION
(N = 2 for samples; N = 1 for controls)

Test	Soil	Leach Day	Zn	Cl ($\mu\text{g}/\text{cm}^2$)	P	%PO4-P /Ptot	Cl/Zn Ratio	Vd as P ^(a) (10^3 cm^3)	Vd as Cl ^(a)
CONTROL	BURBANK 1C	1	0.00	0.10	0.31	83			
CONTROL	BURBANK 2C	2	0.00	0.00	0.37	68			
CONTROL	BURBANK 1C	5	0.00	0.09	0.20	~100			
CONTROL	BURBANK 2C	9	0.00	0.11	0.18	~100			
CONTROL	BURBANK 1C	15	0.00	0.13	0.06	~100			
CONTROL	BURBANK 2C	15	0.00	0.10	0.19	~100			
		Ave	0.00	0.09	0.22				
		STD DEV	0.00	0.04	0.11				
MS-3	BURBANK	1	3.3	23.2	34.6	41.6	7.1	23.8	22.6
MS-3	BURBANK	2	2.7	23.7	33.7	46.5	8.9	23.9	23.1
MS-3	BURBANK	5	2.1	24.1	33.6	57.9	11.8	23.2	23.5
MS-3	BURBANK	9	1.9	23.7	32.4	68.7	12.6	22.4	23.2
MS-3	BURBANK	15	1.6	24.7	32.4	81.6	15.8	21.6	24.6
CONTROL	MAXEY 1C	1	0.62	0.24	0.00				
CONTROL	MAXEY 2C	2	0.02	3.0 ^(a)	0.07				
CONTROL	MAXEY 1C	5	0.01	0.60 ^(a)	0.00				
CONTROL	MAXEY 2C	9	0.00	0.27	0.00				
CONTROL	MAXEY 1C	15	0.00	0.29	0.00				
CONTROL	MAXEY 2C	15	0.00	0.29	0.00				
		Ave	0.11	0.34	0.01				
		STD DEV	0.25	0.15	0.03				
MS-3	MAXEY	1	7.1	24.6	16.8	28.6	3.5	11.6	23.8
MS-3	MAXEY	2	6.7	26.4	15.0	25.0	4.0	10.4	25.5
MS-3	MAXEY	5	6.2	25.0	11.6	28.7	4.0	8.1	24.2
MS-3	MAXEY	9	5.9	25.4	9.5	35.4	4.3	6.6	24.6
MS-3	MAXEY	15	5.8	27.2	7.6	46.0	4.7	5.2	26.3
(FRESH)									
CONTROL	F PALOUSE 1C	1	0.00	0.23	0.84	~100			
CONTROL	F PALOUSE 2C	2	0.00	0.18	0.99	85.2			
CONTROL	F PALOUSE 1C	5	0.00	0.13	0.99	100.1			
CONTROL	F PALOUSE 2C	9	0.00	0.15	1.09	99.2			
CONTROL	F PALOUSE 1C	15	0.00	0.18	0.4 ^(a)	~100			
CONTROL	F PALOUSE 2C	15	0.00	0.17	1.07 ^(b)	~100			
		Ave	0.00	0.17	1.00				
		STD DEV	0.00	0.03	0.10				
MS-3	F PALOUSE 1	1	1.3	24.9	25.7	62.0	19.7	17.2	24.2
MS-3	F PALOUSE 1	2	1.2	25.1	25.4	68.5	21.2	16.9	24.4

TABLE 3.16. (Cont.)

Test	Soil	Leach Day	Zn	Cl ($\mu\text{g}/\text{cm}^2$)	P	%PO ₄ -P /P _{tot}	Cl/Zn Ratio	Vd as P ^(a) (10^3 cm/sec)	Vd as C ^(a)	
MS-3	F PALOUSE 1	5	1.1	24.7	24.3	81.5	22.8	16.2	24.0	
MS-3	F PALOUSE 1	9	1.0	25.2	24.2	90.9	24.6	16.1	24.5	
MS-3	F PALOUSE 1	15	1.0	27.5	25.1	99.5	28.7	16.7	26.8	
MS-3	F PALOUSE 2	1	0.5	24.4	22.6	71.8	50.5	15.0	23.7	
MS-3	F PALOUSE 2	2	0.4	24.7	23.0	77.2	55.1	15.3	24.1	
MS-3	F PALOUSE 2	5	0.4	24.7	23.7	91.4	55.2	15.8	24.1	
MS-3	F PALOUSE 2	9	0.4	24.5	25.3	94.1	59.4	16.9	23.8	
MS-3	F PALOUSE 2	15	0.3	26.2	26.9	96.6	77.1	18.0	25.5	
(AGED)										
CONTROL	PALOUSE 1C	1	0.00	0.18	0.35	76.5				
CONTROL	PALOUSE 2C	2	0.00	0.14	0.41	72.3				
CONTROL	PALOUSE 1C	5	0.00	0.21	0.30	148.6				
CONTROL	PALOUSE 2C	9	0.00	0.19	0.42	108.8				
CONTROL	PALOUSE 1C	15	0.00	0.18	0.12	345.1				
CONTROL	PALOUSE 2C	15	0.00	0.17	0.36	130.5				
	Ave		0.00	0.18	0.33					
	STD DEV		0.00	0.02	0.11					
MS-3	PALOUSE	1	0.6	25.4	21.5	65.0	39.8	14.7	24.7	
MS-3	PALOUSE	2	0.5	26.0	21.2	75.8	49.8	14.5	25.2	
MS-3	PALOUSE	5	0.4	25.8	20.6	91.6	55.4	14.1	24.9	
MS-3	PALOUSE	9	0.4	25.7	21.5	94.8	68.9	14.7	25.0	
MS-3	PALOUSE	15	0.3	27.6	23.0	99.2	86.0	15.7	26.8	
CONTROL	YAMAC 1C	1	0.00	17.21	0.60	57.8				
CONTROL	YAMAC 2C	2	0.00	18.26	0.62	56.8				
CONTROL	YAMAC 1C	5	0.00	17.68	0.42	104.3				
CONTROL	YAMAC 2C	9	0.00	18.43	0.42	102.1				
CONTROL	YAMAC 1C	15	0.00	18.34	0.36	106.9				
CONTROL	YAMAC 2C	15	0.00	18.90	0.42	93.2				
	Ave		0.00	18.14	0.48					
	STD DEV		0.00	0.60	0.11					
MS-3	YAMAC	1	0.2	46.2	22.2	51.2	296	14.7	27.6	
MS-3	YAMAC	2	0.10	47.1	16.6	78.6	489	11.2	28.4	
MS-3	YAMAC	5	0.05	46.8	22.2	77.9	963	15.0	28.0	
MS-3	YAMAC	9	0.03	47.2	23.0	93.4	1558	15.6	28.4	
MS-3	YAMAC	15	0.02	50.8	25.0	106.6	1881	17.0	32.0	
MS-5	BURBANK	1	5.9	50.2	42.8	44.5	8.5	27.8	46.8	
MS-5	BURBANK	5	5.0	52.6	41.2	52.6	10.2	26.8	48.2	
MS-5	BURBANK	13	4.5	53.4	38.8	70.4	11.9	25.2	49.8	
MS-5	MAXEY	1	10.8	52.8	19.4	30.6	4.9	12.6	49.0	
MS-5	MAXEY	5	10.8	54.1	16.9	25.6	5.0	11.1	50.2	
MS-5	MAXEY	13	10.8	56.9	12.8	31.1	5.3	8.4	52.8	

(a) Vd adjusted for the estimated contribution from soil, by subtracting average control soil value.

(b) Analysis suspect because of falling out of range of similar analyses; was not used in average.

Similarly, for test MS-5, expected leachate concentrations were:

Zn: 24.2 ppm; 23.2 ppm,
P: 82.9 ppm; 85.3 ppm, and
Cl: 70.2 ppm (based on wet only).

Deposition of HC smoke onto soils, as determined by CI values, correlates well with that of wet deposition plates; comparison to dry deposition plates cannot be done because of loss of CI, as discussed earlier. Calculated deposition velocity of P onto soils, as related to the solubilized P in the soil leachates, is misleading and varies widely with the soil type, with a maximum of about 78% of the dry deposition plate rate. This result is similar to earlier exposures of soils to single-smoke RP or WP, where the maximum amount of solubilized P from soils was about 80-85% of the dry deposition plate concentration (Van Voris et al. 1987). These results support the hypothesis that precipitation/adsorption mechanisms are controlling the soluble P, as was also seen earlier the RP/BR and WP soil exposures.

Deposition Velocities

Deposition velocities have been determined from both wet and dry surfaces and also from the soil coupons exposed during the MS tests. The deposition values are included in the corresponding tables: deposition coupons, Table 3.13; dry deposition plates, Table 3.15; wet deposition plates, Table 3.14; and soil deposition Table 3.16. The deposition velocities are summarized in Table 3.17. As expected, deposition velocity increases with increasing wind speed (MS-3-6), but the effect is most notable on the suspended filters, which are more prone to changing orientation at higher wind speeds, with a resultant rise in impaction contribution.

Deposition velocities based on P generally show similar deposition onto wet and dry plates for test series MS-3-6 and MS-8-10 (no wet surfaces exposed during test MS-7), with an average wet/dry ratio of 1.0 ± 0.1 . However, for test series MS-14-15, where HC smoke deposition was absent, the wet/dry ratio averages 1.4, similar to earlier single-smoke WP and RP tests, having wet/dry ratio averaging 1.3 ± 0.1 (Van Voris et al. 1987).

Deposition velocities for individual components of the smokes were similar to those observed during single-smoke exposures, as summarized in Table 3.18. In this table, only the highest wind speed test was omitted from wet and dry deposition averaging, and the highest two wind speeds were omitted on filter deposition averaging because of the increased importance of impaction to total deposited load, as the filters bent in the wind. The MS tests had initial HC generation of 210 to 420 mg/m³; these bracketed the series A and B HC tests, which were at low (160 ± 15 mg/m³) and high (680 ± 40 mg/m³) aerosol concentrations,

TABLE 3.17. SUMMARY OF DEPOSITION VELOCITIES FOR INORGANIC CONSTITUENT OF MIXED-SMOKE AEROSOLS ONTO DIVERSE SURFACES

Test	Surface(a)	N	Function	V_d as P, Zn, Cl (10^3 cm/s)		
				V_d as P	V_d as Zn	V_d as Cl
MS-3	Filter	2	Average	13.7	7.7	4.5
	DD	4	Average	30.7	17.0	0.6
	WD	2	Average	33.6	25.3	28.9
	5 soils	10	Average	16.2	ND ^(b)	24.5
	WD/DD		Ratio	1.1	1.5	47.7
	Filter/DD		Ratio	0.4	0.5	7.5
MS-4	Filter	2	Average	15.9	9.8	5.5
	DD	2	Average	32.3	17.4	0.7
	WD	2	Average	35.1	23.9	35.8
	WD/DD		Ratio	1.1	1.4	54.9
	Filter/DD		Ratio	0.5	0.6	8.4
MS-5	Filter	2	Average	31.5	16.3	7.3
	DD	2	Average	37.6	17.7	1.2
	WD	2	Average	39.1	19.7	47.3
	2 soils	4	Average	20.2	ND	47.9
	WD/DD		Ratio	1.0	1.1	40.5
	Filter/DD		Ratio	0.8	0.9	8.2
	Soil/DD		Ratio	0.5	ND	41.0
MS-6	Filter	2	Average	103.9	56.4	14.5
MS-6	DD	2	Average	52.2	21.3	1.7
MS-6	WD	2	Average	51.7	23.1	73.8
	WD/DD		Ratio	1.0	1.1	44.7
	Filter/DD		Ratio	2.0	2.4	0.2
	Filter					
MS-7	Filter	3	Average	15.0	9.3	5.7
MS-7	DD	4	Average	4.1	10.9	0.3
MS-7	DD-1/0	2	Average	4.3	10.9	0.2
MS-7	DD-0/1	2	Average	23.3 ^(c)	0.1	0.1
	Filter/DD		Ratio	3.6	0.9	18.3
MS-8	Filter	3	Average	20.7	10.5	5.7
MS-8	DD	2	Average	26.7	10.0	0.3
MS-8	DD-1/0	2	Average	NA ^(d)	11.4	10.4
MS-8	DD-0/1	2	Average	29.2	0.1	0.1
MS-8	WD	2	Average	29.2	16.7	26.2
MS-8	WD/NaOH	2	Average	29.3	15.8	30.9
	WD/DD		Ratio	1.1	1.7	82.0
	Filter/DD		Ratio	0.8	1.0	17.9
	NaOH/DD		Ratio	1.1	1.6	96.5

TABLE 3.17. (Cont.)

Test	Surface(a)	N	Function	$V_{d,asP}$	$V_{d,asZn}$ (10^{-3} cms)	$V_{d,asCl}$
MS-9	Filter	3	Average	15.8	7.4	4.3
MS-9	DD	2	Average	22.6	8.6	0.2
MS-9	DD-1/0	2	Average	NA	9.2	9.6
MS-9	DD-0/1	2	Average	25.6	0.1	0.1
MS-9	WD	2	Average	21.6	12.9	20.7
	WD/DD		Ratio	1.0	1.5	95.0
	Filter/DD		Ratio	0.7	0.9	19.7
MS-10	Filter	3	Average	22.3	9.0	4.5
MS-10	DD	2	Average	32.0	9.2	0.4
MS-10	WD	2	Average	30.3	13.8	21.8
	WD/DD		Ratio	0.9	1.5	61.0
	Filter/DD		Ratio	0.7	1.0	12.6
MS-14	Filter	3	Average	15.5	NA	NA
MS-14	DD	4	Average	21.8	NA	NA
MS-14	WD	2	Average	31.2	NA	NA
	WD/DD		Ratio	1.4	NA	NA
	Filter/DD		Ratio	0.7	NA	NA
MS-15	Filter	3	Average	18.1	NA	NA
MS-15	DD	2	Average	27.2	NA	NA
MS-15	DD-0/1	2	Average	27.7	NA	NA
MS-15	WD	2	Average	36.7	NA	NA
	WD/DD		Ratio	1.3	NA	NA
	Filter/DD		Ratio	0.7	NA	NA
MS-16	Filter	3	Average	NA	9.5	11.8
MS-16	DD	2	Average	NA	11.7	11.0
MS-16	DD-1/0	2	Average	NA	11.5 (e)	11.0 (e)
MS-16	WD	2	Average	NA	19.5	30.7
	WD/DD		Ratio	NA	1.7	2.8
	Filter/DD		Ratio	NA	0.8	1.1
MS-17	Filter	3	Average	NA	11.3	13.7
MS-17	DD	2	Average	NA	11.0	10.6
MS-17	WD	2	Average	NA	18.1	27.1
	WD/DD		Ratio	NA	1.6	2.5
	Filter/DD		Ratio	NA	1.0	1.3

(a) Surfaces exposed-suspended glass fiber filters: DD = dry poly Petri plates; WD = DI H₂O in poly Petri plates; WD/NaOH = 0.01 M NaOH in Petri DD-1/0 = not exposed to last smoke; DD-0/1 = exposed only to last smoke.

(b) ND = not determined.

(c) Estimations from test MS-8 concentrations used to estimate proper aerosol concentration.

(d) NA = not applicable; component missing.

(e) Corrected to proper aerosol concentration and time for single-smoke exposure.

respectively. The WP generation as the third phase of the MS runs, averaged 1270 for test series MS3-6, and 2000 for test series MS8-15. By comparison, ranges in aerosol concentrations for the RP and WPE series (Van Voris et al. 1987) were 2000 to 4400 and 2000 to 5600 mg/m³, respectively. Deposition velocities from MS tests based on P showed reasonable independence from the aerosol mass concentration term, theoretically required but not well adhered to by HC test results. Results based on Zn show less independence, while those of Cl are biased because of Cl loss from the dry surfaces before analysis.

TABLE 3.18. SUMMARY OF DEPOSITION VELOCITIES FROM MIXED-SMOKE TESTS COMPARED TO SINGLE-SMOKE EXPOSURES: P DEPOSITIONS (Van Voris et al. 1987), AND HC DEPOSITIONS (Cataldo et al. 1989b)

Test	Surface (a)	N (b)	versus P	versus Zn	V _d versus Cl
		(X10 ³ cm/s).....		
MS-3-5, 8-16	WD	9, 9, 9	31±6	18±5	30±9
RP-A, D series	WD	12, 0, 0	31±1		
WPE1-4 series	WD	8, 0, 0	31±5		
HC22-30A	WD	0, 18, 18		18±2	18±2
HC22-30B	WD	0, 18, 18		29±2	31±2
MS-3-5, 8-16	DD	8, 8, 0	29±4	13±4	NA(c)
RP-A, D series	DD	12, 0, 0	24±9		
WPE1-4 series	DD	8, 0, 0	24±5		
HC22-30A	DD	0, 36, 36		14±3	14±4
HC22-30B	DD	0, 36, 35		20±2	20±2
MS-3-4, 8-16	Filter	7, 7, 7	17±3	9±1	7±4
HC22-30A	Filter	0, 16, 12		5±2	6±1
HC22-30B	Filter	0, 16, 12		8±1	9±1

(a) DD = dry deposition surface, polystyrene petri plate; WD = wet deposition surface, polystyrene Petri plates.

(b) Numbers refer to P, Zn, Cl determinations used in calculations.

(c) NA = not applicable because of loss of Cl from dry surfaces before leaching.

3.2.4 Interaction of Mixed Smokes with Soils

Presence of Polyphosphate Constituents

Soils exposed as thin lens for deposition studies were also studied to determine any changes in solubilized components based on 10-fold water to soil contacts. Early into the data compilation, it became evident that the anion/cation balance (defined as the difference

between cation and anions, divided by their sum, on a meq basis) was yielding poor results when the level of polyphosphate contribution was ignored. Previous data on RP and WP exposures had not included this calculation routinely, but based the level of polyphosphates simply as the difference between total and phosphate-P. Because polyphosphate distribution was also not directly determined via high-pressure liquid chromatography separation for the MS runs, an estimate of the degree of polymerization was done on the non-phosphate component of total P by estimating the average degree of polymerization required for a best fit of the anion/cation balance (Table 3.19). Here, chain length of P_n is used for very large chains, but would also cover significant contribution by cyclic metaphosphates, because as n increases, the calculation of size per charge approaches that of the cyclic structures. The approach is overly simplistic in that it assumes complete dissociation of the polyphosphate anions; in effect, the required average charge on poly-P species is being estimated, based on the equations for linear $(P_nO_{3n+1})^{(n+2)-}$ and cyclic $(P_nO_{3n})^{n-}$ polyphosphates. For Burbank soil exposed during test MS-3, the best fit results from an average chain length (ACL) of about 3, decreasing slightly to <3 at greater than 5 days. During test MS-5, the best fit occurs at ACL of 3-4. For all other soils tested, an ACL of 2 covers most time periods. Tabulated results represent averages of results ($N = 2$) for all samples except for fresh Palouse, where the fresh Palouse 1 had exposure conditions similar to those of the other soils, while fresh Palouse 2 had approximately 50% less mass loading per grams soil exposed; the chain length to provide the best anion/cation balance is not different between the two aliquots, however.

To test the validity of this method, data from two exposed Burbank soil leachates, taken from earlier RP tests (Van Voris et al. 1987), are also included in Table 3.19. The first sample (sample ID No. 7-84-21) was taken on day 2 of water contact following exposure during test RP2 and analyzed for polyphosphate distribution. This sample contained 42% phosphate-P, 19% P2-P4, 10% mP3, and the remaining 28% with $>P4$ chain length; ACL (for $nP > 1P$) was calculated as 5. This is in good agreement with the calculated ACL required to minimize the anion/cation balance. The second sample (sample ID No. 9-84-345) was a 5-day leach aliquot following exposure during RF2-A3. Although not analyzed specifically for polyphosphate distribution, the results show similar trend to that observed in the exposed soil from test RP2.

In the discussions of individual soil types that follow, the anion/cation balances stated (Tables 3.20-3.23) refer only to those calculated using phosphate, not the higher polyphosphates.

TABLE 3.19. PHOSPHATE POLYMERIZATION REQUIRED FOR ANION/CATION BALANCE SOILS EXPOSED TO MIXED SMOKES (N = 2)

Soil	Test	Leach Day	P PO ₄ -P -[µg/mL]-	Anion Total [meq/L]	Cation Total [meq/L]	Balance					
						[DIFF/SUM] Initially	IF P2	IF P3 (Estimates)	IF P4	IF Pn	
BURBANK	MS-3	1	57.2	23.3	1.96	3.70	0.31	-0.05	-0.01	0.02	0.10
BURBANK	MS-3	2	57.2	26.6	2.00	3.72	0.30	-0.03	0.01	0.03	0.11
BURBANK	MS-3	5	55.5	32.2	2.20	3.48	0.23	-0.03	0.00	0.02	0.08
BURBANK	MS-3	9	53.6	36.8	2.33	3.34	0.18	-0.01	0.02	0.03	0.08
BURBANK	MS-3	15	51.8	42.3	2.58	3.14	0.10	-0.01	0.01	0.02	0.04
BURBANK	MS-5	1	70.6	31.4	3.40	5.46	0.23	-0.04	-0.00	0.02	0.08
BURBANK	MS-5	5	68.1	35.8	3.62	5.24	0.18	-0.04	-0.01	0.00	0.06
BURBANK	MS-5	13	64.0	45.0	4.02	4.94	0.10	-0.03	-0.01	0.00	0.03
MAXEY											
MAXEY	MS-3	1	27.6	7.9	2.02	3.41	0.26	0.02	0.05	0.07	0.12
MAXEY	MS-3	2	24.7	6.2	2.02	3.35	0.25	0.02	0.05	0.07	0.12
MAXEY	MS-3	5	19.2	5.4	1.95	3.01	0.21	0.03	0.06	0.07	0.11
MAXEY	MS-3	9	15.6	5.6	1.97	2.83	0.18	0.04	0.06	0.07	0.10
MAXEY	MS-3	15	12.5	5.7	2.13	2.67	0.11	0.02	0.04	0.04	0.07
MAXEY	MS-5	1	32.0	9.8	3.36	4.89	0.19	0.01	0.04	0.05	0.09
MAXEY	MS-5	5	28.0	7.2	3.35	4.77	0.17	0.01	0.03	0.04	0.08
MAXEY	MS-5	13	21.2	6.6	3.53	4.52	0.12	0.01	0.02	0.03	0.06
FRESH											
PALOUSE 1	MS-3	1	42.5	26.3	2.45	3.40	0.16	-0.01	0.01	0.02	0.07
PALOUSE 1	MS-3	2	41.9	28.7	2.49	3.36	0.15	0.00	0.02	0.04	0.07
PALOUSE 1	MS-3	5	40.1	32.7	2.57	3.03	0.08	-0.00	0.01	0.02	0.04
PALOUSE 1	MS-3	9	40.0	36.4	2.74	3.02	0.05	0.01	0.02	0.02	0.03
PALOUSE 1	MS-3	15	41.4	41.2	3.08	3.07	-0.00	-0.00	-0.00	-0.00	-0.00
PALOUSE 2	MS-3	1	18.7	13.4	1.48	1.83	0.10	0.00	0.02	0.03	0.05
PALOUSE 2	MS-3	2	19.0	14.7	1.49	1.88	0.12	0.03	0.05	0.05	0.07
PALOUSE 2	MS-3	5	19.6	17.9	1.56	1.72	0.05	0.02	0.02	0.02	0.03
PALOUSE 2	MS-3	9	20.9	19.7	1.68	1.80	0.03	0.01	0.01	0.02	0.02
PALOUSE 2	MS-3	15	22.2	21.4	1.86	1.93	0.02	0.00	0.01	0.01	0.01
AGED											
PALOUSE	MS-3	1	35.6	23.1	2.05	2.87	0.17	0.00	0.02	0.039	0.078
PALOUSE	MS-3	2	35.0	26.6	2.14	2.83	0.14	0.03	0.04	0.05	0.08
PALOUSE	MS-3	5	34.0	31.2	2.28	2.58	0.06	0.02	0.03	0.03	0.04
PALOUSE	MS-3	9	35.6	33.7	2.37	2.60	0.05	0.02	0.02	0.03	0.03
PALOUSE	MS-3	15	37.9	37.6	2.62	2.67	0.01	0.01	0.01	0.01	0.01
YAMAC											
YAMAC	MS-3	1	35.8	18.4	4.72	6.44	0.15	0.05	0.06	0.07	0.10
YAMAC	MS-3	2	27.4	21.4	4.88	7.16	0.19	0.15	0.16	0.16	0.17
YAMAC	MS-3	5	36.6	28.6	5.22	7.04	0.15	0.10	0.11	0.11	0.12
YAMAC	MS-3	9	37.9	35.4	5.60	7.06	0.12	0.10	0.10	0.10	0.11
YAMAC	MS-3	15	41.4	44.0	6.13	7.45	0.10	0.11	0.11	0.11	0.11
RP EXPOSURES											
BURBANK	RP2	2	29.5	12.4	0.660	1.431	0.369	-0.104	-0.049	-0.019	0.08
BURBANK	1RF2-A3	5	81.1	45.0	1.678	2.892	0.266	-0.161	-0.111	-0.084	0.009

TABLE 3.20. INORGANIC CHEMICAL ANALYSIS OF MIXED-SMOKE EXPOSED SOIL LEACHATE SOLUTIONS WITH TIME: BURBANK

Soil Type	Test	Leach Day No.	pH [.03] ^a	Al [.002]	Ba [.01]	Ca [.005]	Fe [.3]	K
BURBANK 1C	CONTROL	1	7.81	<	<	4.2	0.026	13.1
BURBANK 2C	CONTROL	2	7.85	0.07	<	4.8	0.037	15.0
BURBANK 1C	CONTROL	5	7.82	<	0.003	4.9	<	16.1
BURBANK 2C	CONTROL	9	7.79	<	<	6.9	0.028	15.8
BURBANK 1C	CONTROL	15	7.85	<	0.008	6.5	0.021	17.1
BURBANK 2C	CONTROL	15	8.04	<	0.003	6.6	0.024	15.9
BURBANK 1	MS-3	1	5.13	6.70	0.029	29.8	1.440	25.0
BURBANK 2	MS-3	1	5.04	6.51	0.070	30.1	1.480	25.0
BURBANK 1	MS-3	2	5.31	6.26	0.051	29.9	1.220	26.0
BURBANK 2	MS-3	2	5.28	6.66	0.060	31.3	1.380	26.0
BURBANK 1	MS-3	5	5.89	5.11	0.038	29.5	0.834	25.0
BURBANK 2	MS-3	5	5.48	5.60	0.038	29.7	0.963	25.0
BURBANK 1	MS-3	9	5.47	4.28	0.034	29.5	0.580	24.5
BURBANK 2	MS-3	9	5.50	4.39	0.033	29.8	0.600	24.9
BURBANK 1	MS-3	15	5.55	2.24	0.023	29.2	0.280	25.9
BURBANK 2	MS-3	15	5.56	2.37	0.021	29.2	0.270	25.8
BURBANK 1	MS-5	1	4.30	10.8	0.197	44.9	2.390	29.1
BURBANK 2	MS-5	1	4.35	10.4	0.180	43.9	2.130	28.9
BURBANK 1	MS-5	5	4.64	8.98	0.140	45.8	1.690	29.1
BURBANK 2	MS-5	5	4.64	8.60	0.130	44.0	1.590	28.4
BURBANK 1	MS-5	13	4.85	4.66	0.083	47.9	0.560	29.6
BURBANK 2	MS-5	13	4.86	5.25	0.082	46.2	0.700	28.6
BURBANK	+HCl ^(b)	5	6.86	<	0.027	14.5	0.020	16.5
BURBANK	+H ₃ PO ₄ ^(c)	1	3.4	1.75	0.240	58.6	0.920	26.1

Soil Type	Test	Leach Day No.	K [.3]	Mg [.06]	Mn [.002]	Na [.01]	P [.1]
BURBANK 1C	CONTROL	1	13.1	0.8	<	0.15	0.5
BURBANK 2C	CONTROL	2	15.0	1.0	0.003	0.16	0.6
BURBANK 1C	CONTROL	5	16.1	1.2	<	0.07	0.3
BURBANK 2C	CONTROL	9	15.8	1.4	<	<	0.3
BURBANK 1C	CONTROL	15	17.1	1.7	<	<	0.1
BURBANK 2C	CONTROL	15	15.9	1.4	<	0.13	0.3
BURBANK 1	MS-3	1	25.0	6.4	0.453	0.36	56.8
BURBANK 2	MS-3	1	25.0	6.5	0.462	0.4	57.5
BURBANK 1	MS-3	2	26.0	6.5	0.473	0.53	55.5
BURBANK 2	MS-3	2	26.0	6.7	0.53	0.54	59.0
BURBANK 1	MS-3	5	25.0	6.9	0.474	0.22	55.0

TABLE 3.20. (Cont.)

Soil Type	Test	Leach Day No.	K [.3]	Mg [.06]	Mn [.002]	Na [.01]	P [.1]
BURBANK 2	MS-3	5	25.0	6.9	0.551	0.4	56.0
BURBANK 1	MS-3	9	24.5	6.8	0.55	0.1	53.1
BURBANK 2	MS-3	9	24.9	7.0	0.58	0.1	54.0
BURBANK 1	MS-3	15	25.9	7.1	0.57	0.58	50.9
BURBANK 2	MS-3	15	25.8	7.2	0.58	0.7	52.7
BURBANK 1	MS-5	1	29.1	9.4	1.05	0.59	71.9
BURBANK 2	MS-5	1	28.9	9.3	1.05	0.54	69.4
BURBANK 1	MS-5	5	29.1	10.4	1.35	0.34	69.7
BURBANK 2	MS-5	5	28.4	10.1	1.32	0.33	66.5
BURBANK 1	MS-5	13	29.6	11.5	1.65	0.45	65.0
BURBANK 2	MS-5	13	28.6	11.1	1.60	0.37	63.0
BURBANK	+HCl (b)	5	16.5	3.0	<	0.412	0.5
BURBANK	+H ₃ PO ₄ (c)	1	26.1	11.9	0.8	0.92	164.0
Soil Type	Test	Leach Day No.	Si [.02]	Sr [.002]	Zn [.02]	NH ₄ ⁺ [.05]	DOC [0.1]
BURBANK 1C	CONTROL	1	4.15	0.014	<	0.15	4.5
BURBANK 2C	CONTROL	2	5.46	0.016	<	0.19	5.1
BURBANK 1C	CONTROL	5	6.48	0.017	<	0.06	4.7
BURBANK 2C	CONTROL	9	7.35	0.026	<	<	4.1
BURBANK 1C	CONTROL	15	8.53	0.033	<	0.05	4.2
BURBANK 2C	CONTROL	15	7.98	0.023	<	0.04	4.3
BURBANK 1	MS-3	1	9.76	0.132	5.17	0.18	9.4
BURBANK 2	MS-3	1	10.6	0.134	5.63	0.27	10.7
BURBANK 1	MS-3	2	14.2	0.125	4.21	0.17	9.5
BURBANK 2	MS-3	2	14.7	0.132	4.63	0.16	10.1
BURBANK 1	MS-3	5	19.6	0.131	3.09	0.13	8.6
BURBANK 2	MS-3	5	20.1	0.133	3.65	0.11	8.3
BURBANK 1	MS-3	9	24	0.130	3.00	0.24	8.2
BURBANK 2	MS-3	9	24.3	0.130	3.20	0.18	8.3
BURBANK 1	MS-3	15	27.7	0.130	2.64	0.33	8.6
BURBANK 2	MS-3	15	27.8	0.130	2.62	0.32	8.1
BURBANK 1	MS-5	1	12.8	0.216	9.68	0.28	18.1
BURBANK 2	MS-5	1	13.3	0.212	9.88	0.26	17.4
BURBANK 1	MS-5	5	26.4	0.230	8.27	<	14.6
BURBANK 2	MS-5	5	25.9	0.215	8.42	<	14.5
BURBANK 1	MS-5	13	38.1	0.230	7.23	0.06	12.7
BURBANK 2	MS-5	13	37.6	0.220	7.63	0.10	12.8
BURBANK	+HCl (b)	5	10	0.061	<	ND	4.8
BURBANK	+H ₃ PO ₄ (c)	1	18	0.307	0.02	ND	8.2

TABLE 3.20. (Cont.)

Soil Type	Test	Leach Day No.	Cl ⁻	NO ₂ ⁻ [.04]	NO ₃ ⁻ [.06]	PO ₄ ⁻³ (e) [.1]	SO ₄ ⁼ [.06]	An/Cation Balance [Diff/Sum]
BURBANK 1C	CONTROL	1	0.16	0.21	1.5	1.3	0.4	0.036
BURBANK 2C	CONTROL	2	0.23	0.43	1.0	1.3	0.4	0.245
BURBANK 1C	CONTROL	5	0.15	1.00	2.6	1.5	0.9	-0.061
BURBANK 2C	CONTROL	9	0.17	0.03	4.3	1.5	0.5	-0.042
BURBANK 1C	CONTROL	15	0.21	0.07	6.5	1.5	1.4	-0.006
BURBANK 2C	CONTROL	15	0.16	<	5.1	1.5	0.7	-0.049
BURBANK 1	MS-3	1	38.27	<	0.9	72.5	0.7	0.313
BURBANK 2	MS-3	1	38.19	<	1.0	73.2	0.7	0.304
BURBANK 1	MS-3	2	39.13	<	0.9	80.6	0.7	0.292
BURBANK 2	MS-3	2	39.26	<	0.8	82.4	0.6	0.308
BURBANK 1	MS-3	5	38.55	<	0.9	95.6	0.8	0.231
BURBANK 2	MS-3	5	40.93	<	0.9	101.5	0.8	0.220
BURBANK 1	MS-3	9	39.30	<	0.9	110.1	0.8	0.181
BURBANK 2	MS-3	9	39.10	<	1.0	115.6	0.8	0.177
BURBANK 1	MS-3	15	40.69	<	0.9	124.4	0.9	0.112
BURBANK 2	MS-3	15	42.64	<	1.0	134.9	1.0	0.083
BURBANK 1	MS-5	1	83.80	<	0.8	97.0	1.0	0.235
BURBANK 2	MS-5	1	81.95	<	1.2	95.7	1.1	0.232
BURBANK 1	MS-5	5	84.21	<	0.9	112.4	2.0	0.191
BURBANK 2	MS-5	5	86.32	<	1.4	107.4	1.9	0.174
BURBANK 1	MS-5	13	88.90	<	0.9	144.5	2.7	0.097
BURBANK 2	MS-5	13	87.60	<	1.5	131.6	2.8	0.110
BURBANK	+HCl (b)	5	44.0	<	4.3	2.1	1.1	-0.028
BURBANK	+H ₃ PO ₄ (c)	1	0.18	<	0.7	496	1.3	ND (d)

(a) Analytical detection limit.

(b) See Progress Report No. 34, Table IV.1 (Raw Data ID No. 11-86-163).

(c) Earlier raw data (ID No. 4-85-82), done under P Aerosol Program.

(d) ND - not determined.

(e) Assumes phosphate as H₂PO₄⁻ for balance purposes.

Burbank Soil Exposure to Mixed Smokes

Chemical analysis of Burbank leachate solutions over time is presented in Table 3.20. Also included are earlier data from acidified controls using HCl and H₃PO₄ as acid sources (Van Voris et al. 1987; Cataldo et al. 1989b). For those earlier data, minor corrections in the calculations have made small changes in numerical results relative to those referenced, but do not change any of the trends observed. More species are included in the listings than previously reported, to allow for easier intercomparisons between soils.

Exposure at the high loading level (MS-5) generally showed corresponding general initial increases in soluble species, relative to test MS-3 soils. Based on dry deposition plates, the maximum initial Zn solubility was 24 and 42% for tests MS-3 and MS-5, respectively; similarly, P solubility ranked at 66 and 84%, while Cl solubility versus wet deposition plates was 94 to 118%, and so is considered the best measure of actual deposition. Species that show solubilities that cannot be attributed to simple acidification were Al, Fe, and Si. Amount of Al added by the MS aerosol itself was estimated at 0.7 and 2.5 ppm for tests MS-3 and MS-5, respectively, based on deposition filter data (Table 3.13) using chloride as a reference and assuming total solubility in the water extract. Observed initial Al solubility greatly exceeded those estimates. Solubility of Al, Fe, and P decreased with time, supporting mineralization. The Mn solubility showed a slight increase with time, but was strongly affected by small changes in pH levels in the region of pH 5. Because phosphate precipitates are initially amorphous and may show initial solubilities much higher than those of crystalline minerals, further elucidation of minerals controlling solubility in these solutions would require conversion of concentrations to activities and application of chemical modeling techniques.

Although increased nitrate levels and peaking in nitrite levels in controls corresponded to active microbial modifications, no nitrate change and undetectable nitrite concentrations were seen in the exposed soils. Dissolved ammonia levels increased slightly over the leaching period from test MS-3, suggesting that little microbial activity had commenced. Dissolved organic carbon (DOC) levels were elevated, but decreased slightly during the leaching intervals for both tests. No effort was made to directly determine any contribution to DOC by the FO aerosol, although earlier tests with CO₂-saturated water suggested solubility of around 3 ppm, maximum.

Maxey Flats Soil Exposure to Mixed Smokes

Chemical analysis of Maxey Flats leachate solutions is presented in Table 3.21. The single elevated Cl value determined for control at day 2 has been attributed to a contamination problem with that individual sample, because reanalysis of the same aliquot confirmed the

concentration, but later samples agreed with the day 1 analysis. Based on dry deposition plates, the maximum initial Zn solubilities were 11 and 76% for tests MS-3 and MS-5, respectively; similarly, P solubilities ranked at 43 and 38%, while Cl solubilities versus wet deposition plates were 97 to 121%, and so are considered the best measure of actual deposition. Species that exhibit altered solubility not attributed solely to acid effects are Al and Fe. The Si levels were low and of the same magnitude as those observed under acidic conditions. The Mn levels were elevated and increased with time, but were likely directly controlled by acidity. The higher mass loading of test MS-5 resulted in corresponding

increases in soluble component concentrations. Nitrate levels of both controls and exposed soils were high and similar, while soluble ammonia levels in exposed soils were slightly elevated.

Palouse Soil Exposure to Mixed Smokes

Chemical analysis of Palouse leachate solutions is given in Table 3.22. Fresh Palouse soils were exposed at two mass loadings: fresh Palouse 1 was at loadings similar to other soils exposed during MS-3; fresh Palouse 2 had approximately 50% of the mass loading of fresh Palouse 1, on a gram soil basis. As is typical of stored soils, the Palouse controls showed an elevation or "flush" of some soluble components (Ca, Si, NH_4^+ , DOC), relative to the fresh (undried) Palouse controls. The high nitrate and low soluble ammonia levels in fresh Palouse controls suggested enhanced microbial activity. Because Palouse soil was added to the exposure group primarily because of its use in the microbial studies, no data were available on acidified controls.

Based on dry deposition plates, the maximum initial Zn solubility was 10 and 5% for fresh Palouse and Palouse, respectively; similarly, P solubility ranked at 65 and 54%, while Cl solubility versus wet deposition plates was 100% for both, and so is considered the best measure of actual deposition. Relative to control, initial solubility was enhanced for most species, with Al solubility decreasing with time. Solubility of Al, K, Zn, NO_3^- and, to a lesser extent, P and Sr was higher from exposed fresh Palouse relative to Palouse, while decreased solubility from exposed fresh Palouse was observed for Mn, Si, NH_4^+ , and DOC. Solubility of P remained steady throughout the leaching interval. The elevated (and climbing) level of soluble ammonia in exposed Palouse coupled with the low nitrate levels and minor nitrite levels occurring at the longer solution contact times suggests that the microbial community is relatively inactive in that soil.

TABLE 3.21. INORGANIC CHEMICAL ANALYSIS OF MIXED SMOKE EXPOSED SOIL LEACHATE SOLUTIONS WITH TIME: MAXEY FLATS

Soil Type	Test	Leach Day No.	pH	Al [.03]	Ba [.002]	Ca [.01]	Co [.01]
MAXEY 1C	CONTROL	1	4.81	0.77	0.043	5.10	<
MAXEY 2C	CONTROL	2	4.90	0.60	0.038	4.89	<
MAXEY 1C	CONTROL	5	4.97	0.47	0.070	4.30	<
MAXEY 2C	CONTROL	9	5.04	0.43	0.056	4.10	<
MAXEY 1C	CONTROL	15	5.01	0.37	0.064	4.05	<
MAXEY 2C	CONTROL	15	5.03	0.38	0.049	4.07	<
MAXEY 1	MS-3	1	3.72	11.30	0.237	14.70	0.02
MAXEY 2	MS-3	1	3.68	10.90	0.251	14.70	0.02
MAXEY 1	MS-3	2	3.82	10.40	0.235	15.00	0.03
MAXEY 2	MS-3	2	3.80	10.30	0.248	15.20	0.03
MAXEY 1	MS-3	5	3.95	8.01	0.230	14.10	<
MAXEY 2	MS-3	5	3.91	8.01	0.230	14.20	<
MAXEY 1	MS-3	9	4.01	6.21	0.300	14.00	<
MAXEY 2	MS-3	9	3.97	6.33	0.330	14.30	<
MAXEY 1	MS-3	15	4.04	4.08	0.160	13.70	0.03
MAXEY 2	MS-3	15	4.02	4.42	0.180	14.10	0.03
MAXEY 1	MS-5	1	3.28	15.20	0.447	20.50	0.04
MAXEY 2	MS-5	1	3.26	14.70	0.441	20.30	0.04
MAXEY 1	MS-5	5	3.46	13.20	0.457	21.10	0.06
MAXEY 2	MS-5	5	3.45	13.50	0.458	20.70	0.06
MAXEY 1	MS-5	13	3.6	9.47	0.410	21.50	0.07
MAXEY 2	MS-5	13	3.58	10.20	0.430	21.30	0.07
MAXEY	+HCl (b)	5	4.49	0.62	0.214	12.50	0.02
MAXEY	+H ₃ PO ₄ (c)	1	3.07	7.52	0.510	23.30	0.03
MAXEY 1C	CONTROL	1	0.103	2.0	1.01	2.56	0.19
MAXEY 2C	CONTROL	2	0.097	3.2	1.00	2.49	0.19
MAXEY 1C	CONTROL	5	0.049	3.4	0.89	2.59	0.08
MAXEY 2C	CONTROL	9	0.062	1.9	0.83	2.47	<
MAXEY 1C	CONTROL	15	0.042	3.3	0.84	2.56	<
MAXEY 2C	CONTROL	15	0.047	1.6	0.82	1.90	0.25
MAXEY 1	MS-3	1	0.725	4.1	2.43	8.06	0.17
MAXEY 2	MS-3	1	0.700	3.7	2.37	7.92	0.21
MAXEY 1	MS-3	2	0.524	4.6	2.45	8.80	0.39
MAXEY 2	MS-3	2	0.510	5.0	2.44	8.80	0.36
MAXEY 1	MS-3	5	0.360	3.1	2.45	9.47	<
MAXEY 2	MS-3	5	0.360	3.1	2.44	9.42	0.20
MAXEY 1	MS-3	9	0.280	2.1	2.36	10.30	<
MAXEY 2	MS-3	9	0.290	2.7	2.41	10.40	<
MAXEY 1	MS-3	15	0.220	3.8	2.43	11.00	0.18
MAXEY 2	MS-3	15	0.240	3.9	2.48	11.30	0.43
MAXEY 1	MS-5	1	0.789	4.9	3.03	11.70	0.28
MAXEY 2	MS-5	1	0.733	4.9	3.06	11.90	0.29
MAXEY 1	MS-5	5	0.546	3.3	3.21	16.20	0.08
MAXEY 2	MS-5	5	0.563	3.4	3.20	16.10	<
MAXEY 1	MS-5	13	0.420	3.3	3.36	20.20	0.29

TABLE 3.21. (Cont.).

Soil Type	Test	Leach Day No.	Fe [.005]	K [.3]	Mg [.06]	Mn [.002]	Na [.01]
MAXEY 2	MS-5	13	0.440	3.2	3.36	20.30	0.28
MAXEY	+HCl (b)		0.070	4.0	2.22	7.84	0.37
MAXEY	+H ₃ PO ₄ (c)		0.285	4.0	3.36	10.00	0.45
			Si [.02]	Sr [.002]	Zn [.02]	NH ₄ ⁺ [.05]	DOC [.1]
MAXEY 1C	CONTROL	1	0.76	0.024	1.03	3.14	27.4
MAXEY 2C	CONTROL	2	1.03	0.022	0.03	3.60	26.5
MAXEY 1C	CONTROL	1	1.13	0.022	0.02	4.49	28.6
MAXEY 2C	CONTROL	2	1.40	0.020	<	5.25	29.1
MAXEY 1C	CONTROL	1	1.76	0.021	<	5.51	29.1
MAXEY 2C	CONTROL	2	1.74	0.020	<	5.67	27.3
MAXEY 1	MS-3	1	1.51	0.073	11.70	4.38	53.5
MAXEY 2	MS-3	1	1.45	0.072	11.60	4.31	49.1
MAXEY 1	MS-3	2	2.07	0.071	11.00	4.70	50.7
MAXEY 2	MS-3	2	2.05	0.071	11.00	4.59	49.2
MAXEY 1	MS-3	5	2.76	0.073	10.30	6.00	51.6
MAXEY 2	MS-3	5	2.68	0.072	10.30	5.71	50.1
MAXEY 1	MS-3	9	3.39	0.070	9.73	6.49	51.6
MAXEY 2	MS-3	9	3.39	0.071	9.81	6.49	50.7
MAXEY 1	MS-3	15	4.20	0.070	9.41	7.00	51.3
MAXEY 2	MS-3	15	4.15	0.072	9.59	6.84	50.2
MAXEY 1	MS-5	1	2.07	0.103	17.50	4.66	66.0
MAXEY 2	MS-5	1	2.12	0.103	18.10	4.66	65.5
MAXEY 1	MS-5	5	4.18	0.110	17.70	6.36	66.7
MAXEY 2	MS-5	5	4.13	0.110	18.00	6.49	65.1
MAXEY 1	MS-5	13	6.32	0.110	17.60	7.41	63.1
MAXEY 2	MS-5	13	6.28	0.110	17.90	7.55	63.9
MAXEY 1	+HCl (b)		1.63	0.065	0.08	ND (d)	24.3
MAXEY 2	+H ₃ PO ₄ (c)		3.42	0.125	0.26	ND	39.8
			NO ₂ ⁻ [.04]	NO ₃ ⁻ [.06]	PO ₄ ⁻³ (a) [.1]	SO ₄ ⁼ [.06]	An/Cation Balance Diff/Sum
MAXEY 1C	CONTROL	1	0.04	27.5	0.04	5.8	0.099
MAXEY 2C	CONTROL	2	<	29.6	0.57	5.3	0.071
MAXEY 1C	CONTROL	5	0.25	28.5	0.08	7.1	0.097

3.49

TABLE 3.21. (Cont.).

Soil Type	Test	Leach Day No.	NO ₂ ⁻ [04]	NO ₃ ⁻ [.06]	PO ₄ ⁻³ (a) [.1]	SO ₄ ⁼⁼ [.06]	An/Cation Balance Diff/Sum
MAXEY 2C	CONTROL	9	0.04	28.8	<	6.1	0.097
MAXEY 1C	CONTROL	15	0.05	29.7	0.03	8.1	0.084
MAXEY 2C	CONTROL	15	0.05	31.1	<	6.9	0.060
MAXEY 1	MS-3	1	<	28.3	24.86	5.4	0.269
MAXEY 2	MS-3	1	<	28.0	23.45	5.1	0.242
MAXEY 1	MS-3	2	<	28.3	19.46	5.8	0.263
MAXEY 2	MS-3	2	<	27.7	18.46	5.8	0.233
MAXEY 1	MS-3	5	<	28.5	17.52	6.3	0.217
MAXEY 2	MS-3	5	<	28.0	16.33	6.2	0.211
MAXEY 1	MS-3	9	<	28.8	17.70	6.7	0.174
MAXEY 2	MS-3	9		28.2	16.22	6.8	0.181
MAXEY 1	MS-3	15		30.9	18.20	7.4	0.114
MAXEY 2	MS-3	15		31.0	17.00	7.5	0.114
MAXEY 1	MS-5	1		26.9	30.10	5.5	0.193
MAXEY 2	MS-5	1		27.3	29.70	5.6	0.180
MAXEY 1	MS-5	5		27.6	21.53	6.4	0.175
MAXEY 2	MS-5	5		27.7	22.32	6.5	0.173
MAXEY 1	MS-5	13		30.1	20.20	7.7	0.012
MAXEY 2	MS-5	13		29.9	20.20	7.5	0.129
MAXEY 1	+HCl (b)		<	16.1	<	5.3	-0.151
MAXEY 2	+H ₃ PO ₄ (c)		<	16.2	334.00	5.8	ND

(a) Assumes phosphate as H₂PO₄⁻ for balance purposes.

(b) See Progress Report No. 34, Table IV.1 (Raw Data ID No. 11-86-163).

(c) Earlier raw data (ID No. 4-85-62) done under P Aerosol Program.

(d) ND = not determined.

TABLE 3.22. INORGANIC CHEMICAL ANALYSIS OF MIXED-SMOKE EXPOSED SOIL LEACHATE SOLUTIONS WITH TIME: PALOUSE

Soil Type	Test	Leach Day No.	pH	Al [.03]	Ba [.002]	Ca [.01]	Fe [.005]	K [.3]	Li [.004]	Mg [.06]
FR PALOUSE 1C	CONTROL	1	5.88	1.04	0.020	2.3	0.669	15.0	<	0.56
FR PALOUSE 2C	CONTROL	2	5.87	1.52	0.014	2.5	0.930	16.0	0.025	0.66
FR PALOUSE 1C	CONTROL	5	5.88	0.85	0.012	2.1	0.541	14.2	0.011	0.53
FR PALOUSE 2C	CONTROL	9	5.84	0.53	0.018	2.8	0.350	14.6	0.042	0.59
FR PALOUSE 1C	CONTROL	15	5.83	0.57	0.034	3.8	0.380	17.5	<	0.83
FR PALOUSE 2C	CONTROL	15	5.84	0.53	0.021	3.6	0.370	16.8	0.011	0.76
FR PALOUSE 1	MS-3	1	4.52	4.66	0.224	29.3	0.648	31.0	0.044	5.23
FR PALOUSE 1	MS-3	2	4.58	3.85	0.218	29.8	0.414	33.0	0.053	5.16
FR PALOUSE 1	MS-3	5	4.65	2.16	0.190	28.7	0.220	29.9	0.044	5.36
FR PALOUSE 1	MS-3	9	4.70	1.00	0.210	30.2	0.130	30.8	0.091	5.55
FR PALOUSE 1	MS-3	15	4.74	0.33	0.160	30.8	0.074	33.5	0.041	5.73
FR PALOUSE 2	MS-3	1	4.98	1.50	0.094	14.5	0.308	24.8	0.019	2.77
FR PALOUSE 2	MS-3	2	4.99	1.30	0.094	14.8	0.290	27.0	0.053	2.80
FR PALOUSE 2	MS-3	5	5.00	0.57	0.081	14.6	0.150	24.7	0.017	2.91
FR PALOUSE 2	MS-3	9	5.02	0.28	0.100	16.0	0.130	25.9	0.021	3.13
FR PALOUSE 2	MS-3	15	5.07	0.35	0.094	16.9	0.190	28.0	0.026	3.35
PALOUSE 1C	CONTROL	1	6.92	0.06	0.017	4.2	0.076	5.1	0.013	0.78
PALOUSE 2C	CONTROL	2	6.98	0.07	0.008	3.8	0.039	5.2	0.019	0.72
PALOUSE 1C	CONTROL	5	6.86	<	0.015	3.4	<	5.1	<	0.62
PALOUSE 2C	CONTROL	9	6.88	0.10	0.011	3.6	0.099	3.8	0.018	0.64
PALOUSE 1C	CONTROL	15	6.48	<	0.037	7.0	0.099	5.7	<	1.28
PALOUSE 2C	CONTROL	15	6.67	0.13	0.018	5.5	0.140	4.4	0.019	1.02
PALOUSE 1	MS-3	1	5.33	2.92	0.129	31.7	0.438	8.8	0.038	5.93
PALOUSE 2	MS-3	1	5.29	2.94	0.137	32.6	0.443	8.6	0.038	6.08
PALOUSE 1	MS-3	2	5.31	1.84	0.125	32.1	0.209	11.0	0.072	5.85
PALOUSE 2	MS-3	2	5.30	1.82	0.131	32.6	0.205	12.0	0.063	5.96
PALOUSE 1	MS-3	5	5.53	0.60	0.100	30.2	0.078	10.0	0.044	5.93
PALOUSE 2	MS-3	5	5.40	0.59	0.110	31.2	0.078	10.0	0.096	6.10
PALOUSE 1	MS-3	9	5.54	0.19	0.110	31.5	0.041	9.1	0.046	5.98
PALOUSE 2	MS-3	9	5.45	0.16	0.130	32.4	0.038	9.3	0.056	6.16
PALOUSE 1	MS-3	15	5.51	0.06	0.091	31.4	0.024	11.1	0.034	6.08
PALOUSE 2	MS-3	15	5.45	0.06	0.098	32.4	0.024	11.3	0.052	6.27
			Mn [.002]	Na [.01]	P [.1]	Si [.02]	Sr [.002]	Zn [.02]	NH ₄ ⁺ [.05]	
FR PALOUSE 1C	CONTROL	1	0.008	0.37	1.4	6.64	0.017	<	<	
FR PALOUSE 2C	CONTROL	2	0.009	0.49	1.6	9.31	0.017	<	<	
FR PALOUSE 1C	CONTROL	5	0.003	0.19	1.6	10.70	0.015	<	<	
FR PALOUSE 2C	CONTROL	9	<	0.10	1.8	12.10	0.020	<	<	
FR PALOUSE 1C	CONTROL	15	<	0.48	0.6	14.10	0.029	<	0.10	
FR PALOUSE 2C	CONTROL	15	<	0.25	1.8	14.10	0.027	<	0.11	

TABLE 3.22. (Cont.)

Soil Type	Test	Leach Day No.	Mn [.002]	Na [.01]	P [.1]	Si [.02]	Sr [.002]	Zn [.02]	NH ₄ ⁺ [.05]
FR PALOUSE 1	MS-3	1	0.34	0.67	42.5	10.30	0.216	2.09	0.13
FR PALOUSE 2	MS-3	2	0.41	0.84	41.9	13.70	0.209	1.95	0.10
FR PALOUSE 1	MS-3	5	0.49	0.44	40.1	18.90	0.220	1.79	0.18
FR PALOUSE 2	MS-3	9	0.51	0.50	40.0	24.00	0.230	1.60	0.36
FR PALOUSE 1	MS-3	15	0.46	0.68	41.4	28.60	0.230	1.58	0.67
FR PALOUSE 2	MS-3	1	0.11	0.46	18.7	8.29	0.105	0.40	0.07
FR PALOUSE 1	MS-3	2	0.12	0.57	19.0	10.70	0.103	0.37	<
FR PALOUSE 2	MS-3	5	0.10	0.22	19.8	13.90	0.110	0.37	0.06
FR PALOUSE 1	MS-3	9	0.07	0.10	20.0	17.40	0.120	0.34	0.13
FR PALOUSE 2	MS-3	15	0.05	0.33	22.2	20.60	0.120	0.28	0.07
PALOUSE 10	CONTROL	1	0.08	0.74	0.6	9.29	0.020	<	0.58
PALOUSE 20	CONTROL	2	0.03	0.76	0.7	11.70	0.016	<	0.68
PALOUSE 10	CONTROL	5	<	0.63	0.5	14.10	0.016	<	0.71
PALOUSE 20	CONTROL	9	<	0.50	0.7	16.10	0.017	<	0.67
PALOUSE 10	CONTROL	15	<	0.98	0.2	19.40	0.035	<	0.32
PALOUSE 20	CONTROL	15	<	0.72	0.6	18.90	0.027	<	0.38
PALOUSE 1	MS-3	1	1.38	0.99	35.7	16.80	0.115	1.03	1.02
PALOUSE 2	MS-3	1	1.42	0.91	35.4	17.50	0.150	1.05	1.06
PALOUSE 1	MS-3	2	1.40	1.32	35.2	22.60	0.150	0.86	1.19
PALOUSE 2	MS-3	2	1.43	1.25	34.0	22.90	0.152	0.87	1.22
PALOUSE 1	MS-3	5	1.33	0.98	34.1	28.50	0.150	0.69	1.75
PALOUSE 2	MS-3	5	1.39	0.95	34.0	29.00	0.160	0.71	1.77
PALOUSE 1	MS-3	9	1.40	0.80	35.7	32.80	0.160	0.61	2.19
PALOUSE 2	MS-3	9	1.45	1.00	4	33.60	0.160	0.62	2.28
PALOUSE 1	MS-3	15	1.36	1.48	7	35.60	0.150	0.52	2.57
PALOUSE 2	MS-3	15	1.41	0.9	37.8	36.30	0.160	0.54	2.56
			DOO [.1]	Cl ⁻ [.05]	NO ₂ ⁻ [.04]	NO ₃ ⁻ [.06]	PO ₄ ^{-3(A)} [.1]	SO ₄ ²⁻ [.06]	An/Cation Balance Diff/Sum
FR PALOUSE 10	CONTROL	1	5.4	0.38	0.03	23.9	4.4	2.2	0.048
FR PALOUSE 20	CONTROL	2	6.9	0.29	0.03	23.5	4.3	1.8	0.128
FR PALOUSE 10	CONTROL	5	6.7	0.22	0.02	22.5	5.0	2.0	0.150
FR PALOUSE 20	CONTROL	9	6.9	0.25	<	25.3	5.5	2.0	0.098
FR PALOUSE 10	CONTROL	15	6.6	0.30	<	33.3	5.6	2.7	0.091
FR PALOUSE 20	CONTROL	15	6.8	0.28	<	35.5	5.7	2.8	0.056
FR PALOUSE 1	MS-3	1	15.5	41.08	<	22.3	80.7	1.2	0.162
FR PALOUSE 2	MS-3	1	15.1	41.42	<	22.4	88.0	1.6	0.148
FR PALOUSE 1	MS-3	2	14.9	40.79	<	20.1	100.1	1.8	0.082
FR PALOUSE 2	MS-3	2	13.1	41.61	<	21.7	111.5	2.0	0.049
FR PALOUSE 1	MS-3	5	14.6	45.40	<	25.3	126.3	2.6	-0.002
FR PALOUSE 2	MS-3	5	11.5	20.3	0.02	23.1	41.1	1.9	0.105
FR PALOUSE 1	MS-3	9	10.8	20.40	<	23.1	45.0	1.8	0.118
FR PALOUSE 2	MS-3	9	10.9	20.42	<	21.7	54.9	2.1	0.049

TABLE 3.22. (Cont.)

Soil Type	Test	Leach Day No.	DOC [.1]	Cl ⁻ [.05]	NO ₂ ⁻ [.04]	NO ₃ ⁻ [.06]	PO ₄ ³⁻ (a) [.1]	SO ₄ ²⁻ [.06]	An/Cation Balance Diff/Sum
FR PALOUSE 1	MS-3	15	10.4	20.20	<	25.0	60.3	2.6	0.033
FR PALOUSE 2	MS-3	15	10.6	21.60	<	30.4	65.7	2.9	0.019
PALOUSE 1C	CONTROL	1	22.4	0.29	0.11	0.1	1.4	2.4	0.033
PALOUSE 2C	CONTROL	2	20.2	0.22	0.34	1.0	1.5	2.0	0.278
PALOUSE 1C	CONTROL	5	17.4	0.34	0.88	2.2	2.3	2.6	0.239
PALOUSE 2C	CONTROL	9	14.0	0.31	1.15	5.8	2.3	3.0	0.147
PALOUSE 1C	CONTROL	15	11.7	0.30	0.14	24.1	2.1	3.6	0.103
PALOUSE 2C	CONTROL	15	12.3	0.28	0.10	19.2	2.4	3.7	0.073
PALOUSE 1	MS-3	1	32.4	40.7	<	0.6	71.6	2.1	0.171
PALOUSE 2	MS-3	1	31.2	43.0	0.02	0.7	70.2	2.4	0.160
PALOUSE 1	MS-3	2	27.8	41.5	<	0.8	81.4	2.3	0.144
PALOUSE 2	MS-3	2	28.6	44.2	<	0.8	81.4	2.4	0.136
PALOUSE 1	MS-3	5	24.3	41.1	<	0.7	96.2	2.4	0.064
PALOUSE 2	MS-3	5	28.8	43.4	<	0.9	94.8	2.8	0.083
PALOUSE 1	MS-3	9	20.7	41.1	0.07	1.2	103.3	2.8	0.047
PALOUSE 2	MS-3	9	20.3	43.7	0.05	1.3	103.2	2.8	0.045
PALOUSE 1	MS-3	15	16.5	44.0	0.12	2.2	116.1	3.4	0.013
PALOUSE 2	MS-3	15	16.4	47.2	0.10	2.5	114.2	3.5	0.008

(a) Assumes phosphate as H₂PO₄⁻ for ion balance calculation.

Yamac Soil Exposure to Mixed Smokes

Leachate analysis results from Yamac soil extractions are listed in Table 3.23. Based on dry deposition plates, the maximum initial Zn solubility was 1.2%; similarly, P solubility ranked at 54%, while Cl solubility versus wet deposition plates was 119%, and so is considered the best measure of actual deposition. Previous studies with RP deposition (RFT-A3) had shown an increase in soluble Al with increasing time to initial water contact following exposure, in contrast to Burbank, which showed decreased solubility with time to water contact. Because no soils coupons were retained for periodic wetting with time, direct comparison of this factor cannot be made. Components that showed increases in exposed Yamac soil not accounted for by acidification were Al, Fe, and DOC. Sulfate showed a decrease in concentration, unlike other soils exposed. Nitrate and nitrite levels were lagging in exposed Yamac leachates relative to controls, suggesting that the microbial activity is only partially slowed.

TABLE 3.23. INORGANIC CHEMICAL ANALYSIS OF MIXED-SMOKE EXPOSED SOIL LEACHATE SOLUTIONS WITH TIME: YAMAC

Soil Type	Test	Leach Day No.	pH	Al [.03]	Ba [.002]	Ca [.01]	Cu [.004]	Fe [.005]
YAMAC 1C	CONTROL	1	9.20	0.38	0.004	1.89	0.021	0.204
YAMAC 2C	CONTROL	2	8.90	0.24	0.006	2.21	0.028	0.105
YAMAC 1C	CONTROL	5	8.76	<	0.005	2.33	0.020	0.007
YAMAC 2C	CONTROL	9	8.73	<	<	2.40	<	0.025
YAMAC 1C	CONTROL	15	8.78	<	0.004	2.63	0.015	0.008
YAMAC 2C	CONTROL	15	8.8	<	0.004	2.34	0.010	0.049
YAMAC 1	MS3	1	7.97	0.72	0.007	8.83	0.024	0.333
YAMAC 1	MS3	2	8.13	0.64	0.007	7.94	0.035	0.205
YAMAC 1	MS3	5	8.22	0.27	0.003	5.40	0.027	0.070
YAMAC 1	MS3	9	8.26	0.13	<	5.20	0.021	0.042
YAMAC 1	MS3	15	8.35	0.21	0.005	4.63	<	0.089
YAMAC 2	MS3	1	8.00	0.59	0.006	8.42	0.022	0.301
YAMAC 2	MS3	2	8.16	0.45	0.008	8.11	0.034	0.206
YAMAC 2	MS3	5	8.28	0.18	0.004	5.17	0.028	0.099
YAMAC 2	MS3	9	8.32	<	<	5.00	0.022	0.025
YAMAC 2	MS3	15	8.37	0.15	0.006	4.78	0.023	0.100
YAMAC	+HCl (c)	5	8.81	0.14	0.008	6.29	0.019	0.119
YAMAC	+H ₃ PO ₄ (d)	1	7.84	<	0.036	23.00	<	0.044
			K [.3]	Mg [.06]	Mn [.002]	Na [.01]	P [.1]	Si [.02]
YAMAC 1C	CONTROL	1	<	0.38	0.005	100	1.0	5.43
YAMAC 2C	CONTROL	2	0.4	0.51	0.004	124	1.0	5.43
YAMAC 1C	CONTROL	5	<	0.56	<	130	0.7	5.25
YAMAC 2C	CONTROL	9	<	0.55	<	139	0.7	5.76
YAMAC 1C	CONTROL	15	<	0.75	<	142	0.6	5.62
YAMAC 2C	CONTROL	15	<	0.48	<	145	0.7	5.95
YAMAC 1	MS3	1	<	4.16	0.072	130	38.8	8.91
YAMAC 1	MS3	2	1.1	3.97	0.062	146	28.1	9.41
YAMAC 1	MS3	5	<	2.84	0.021	150	37.0	9.43
YAMAC 1	MS3	9	<	2.18	<	153	38.4	10.1
YAMAC 1	MS3	15	0.6	1.57	0.018	160	42.8	9.94
YAMAC 2	MS3	1	<	4.02	0.068	126	34.8	8.25
YAMAC 2	MS3	2	1.6	3.99	0.058	144	28.6	9.11
YAMAC 2	MS3	5	<	2.75	0.016	149	38.2	9.28
YAMAC 2	MS3	9	<	2.09	<	151	37.4	9.64
YAMAC 2	MS3	15	<	1.55	<	164	39.9	9.85
YAMAC	+HCl (c)	5	0.23	1.72	0.011	156	0.5	5.36
YAMAC	+H ₃ PO ₄ (d)	1	<	7.40	0.150	200	113.0	12.3

TABLE 3.23. (Cont.)

Soil Type	Test	Leach Day No	Sr [.002]	Zn [.02]	NH ₄ ⁺ [.05]	DOC [.1]	INORG C DIRECT	Cl ⁻ [.05]
YAMAC 1C	CONTROL	1	0.01	<	0.10	24.8	<	28.4
YAMAC 2C	CONTROL	2	0.01	<	0.11	23.8	39.3	30.2
YAMAC 1C	CONTROL	5	0.01	<	0.10	21.0	50.1	29.2
YAMAC 2C	CONTROL	9	0.01	<	0.09	18.3	54.4	30.4
YAMAC 1C	CONTROL	15	0.01	<	0.04	17.9	57.6	30.3
YAMAC 2C	CONTROL	15	0.01	<	0.05	18.2	56.2	31.2
YAMAC 1	MS3	1	0.03	0.27	0.07	31.4	<	77.1
YAMAC 1	MS3	2	0.02	0.17	0.08	30.7	20.3	78.5
YAMAC 1	MS3	5	0.02	0.08	0.07	29.6	21.5	77.9
YAMAC 1	MS3	9	0.02	0.05	0.05	28.6	23.0	78.8
YAMAC 1	MS3	15	0.02	0.05	0.05	25.8	22.9	85.7
YAMAC 2	MS3	1	0.02	0.25	0.06	29.0	<	75.5
YAMAC 2	MS3	2	0.02	0.15	0.08	30.5	20.0	76.9
YAMAC 2	MS3	5	0.02	0.08	0.07	29.0	21.7	76.4
YAMAC 2	MS3	9	0.02	0.05	0.06	28.0	23.0	76.9
YAMAC 2	MS3	15	0.02	0.04	0.05	25.7	23.6	81.9
YAMAC	+HCl (c)	5	0.03	<	ND (e)	15.32	57.66	72.5
YAMAC	+H ₃ PO ₄ (d)	1	0.1	<	ND	13	26	28.0
			NO ₂ ⁻ [.04]	Br(a) [.06]	NO ₃ ⁻ [.06]	PO ₄ ⁻³ (b) [.1]	SO ₄ ^m [.06]	An/Cation Balance Diff/Sum
YAMAC 1C	CONTROL	1	0.29	0.51	1.4	1.8	15.8	0.035
YAMAC 2C	CONTROL	2	0.41	<	1.1	1.8	16.1	0.102
YAMAC 1C	CONTROL	5	1.03	<	2.0	2.2	17.6	0.029
YAMAC 2C	CONTROL	9	1.86	<	3.2	2.2	19.0	0.022
YAMAC 1C	CONTROL	15	1.24	0.57	8.3	2.0	19.9	0.005
YAMAC 2C	CONTROL	15	0.96	0.63	8.3	2.0	20.1	0.020
YAMAC 1	MS3	1	0.26	0.54	0.8	58.1	11.9	0.158
YAMAC 1	MS3	2	0.21	0.54	1.0	66.9	12.0	0.189
YAMAC 1	MS3	5	0.41	0.45	1.5	88.5	12.3	0.148
YAMAC 1	MS3	9	0.37	0.58	2.8	110.2	12.6	0.115
YAMAC 1	MS3	15	<	0.62	5.4	138.6	14.4	0.086
YAMAC 2	MS3	1	0.26	0.49	0.9	54.3	12.1	0.150
YAMAC 2	MS3	2	0.22	0.50	0.9	64.8	11.8	0.192

TABLE 3.23. (Cont.)

Soil Type	Test	Leach Test No.	NO ₂ ⁻ [.04]	Br ^(a) [.06]	NO ₃ ⁻ [.06]	PO ₄ ⁻³ (b) [.1]	SO ₄ ⁼⁼ [.06]	An/Cation Balance Diff/Sum
YAMAC 2	MS3	5	0.44	0.45	1.4	86.3	11.9	0.149
YAMAC 2	MS3	9	0.45	0.53	2.7	106.6	12.1	0.115
YAMAC 2	MS3	15	<	0.59	5.5	131.4	13.8	0.109
YAMAC	+HC (c)	5	1.78	0.52	4.36	1.5	21.3	-0.014
YAMAC	+H ₃ PO ₄ (d)	1	<	0.48	12	319	21.0	ND

- (a) Br- is tentative ID only, based solely on retention time on IC.
 (b) Assumes phosphate as H₂PO₄⁻ for ion balance calculations.
 (c) Earlier raw data ID 11-86-165.
 (d) Earlier raw data (Test RF2-A3), done under P Aerosol program.
 (e) ND = not determined.

3.3 TERRESTRIAL VEGETATION EFFECTS

3.3.1. Vegetation Mass Loading and Follar Retention of Mixed-Smoke Components

Range-Finding/Wind Speed Tests (RF/WS)

The range-finding/wind speed tests involved ~210-min total exposure consisting of ~70-min sequential doses of HC (~500 mg/m³), FO (~590 mg/m³), followed by WP (~1840 mg/m³). Relative humidity was maintained at 50%, and wind speeds of 2, 4, 6, and 10 mph were employed. As shown in Table 3.24, there was a gradual increase in the foliar mass loading between the lower wind speeds up to 6 mph for each of the mixed-smoke components and in each of the four species that were exposed.

TABLE 3.24. FOLIAR MASS LOADING OF Zn (HC), PHOSPHOROUS (WP) AND FOG OIL FROM MIXED-SMOKE RF/WS TESTS (MS-3-6). TOTAL DURATION OF EXPOSURES WAS APPROXIMATELY 210 MIN AT 50% RELATIVE HUMIDITY.

Species	Wind Speed	Foliar Mass Loading		
		HC-Zinc	WP-Phosphorus	Fog Oil
($\mu\text{g}/\text{cm}^2 \pm \text{s.d.}, n=6$)				
Ponderosa Pine	2 mph	8.49 \pm 0.77	15.67 \pm 1.77	20.10 \pm 20.80
	4 mph	7.96 \pm 0.88	24.60 \pm 13.00	283.24 \pm 116.90
	6 mph	12.01 \pm 1.97	105.82 \pm 40.11	248.92 \pm 49.29
	10 mph	71.91 \pm 18.13	769.88 \pm 233.84	574.65 \pm 231.47
Sagebrush	2 mph	5.36 \pm 1.10	12.49 \pm 2.71	26.36 \pm 13.23
	4 mph	13.54 \pm 1.49	28.08 \pm 3.61	12.94 \pm 12.82
	6 mph	21.06 \pm 4.64	58.93 \pm 13.48	141.58 \pm 43.19
	10 mph	122.77 \pm 39.24	386.58 \pm 218.68	312.58 \pm 128.58
Bush Bean	2 mph	3.18 \pm 0.57	8.62 \pm 2.11	10.27 \pm 8.86
	4 mph	7.40 \pm 1.58	22.56 \pm 5.28	30.92 \pm 10.99
	6 mph	12.25 \pm 2.76	52.38 \pm 13.20	67.40 \pm 22.81
	10 mph	40.78 \pm 28.69	143.64 \pm 93.26	105.28 \pm 61.38
Tall Fescue	2 mph	2.64 \pm 0.50	7.97 \pm 1.63	5.79 \pm 1.63
	4 mph	3.20 \pm 0.53	10.80 \pm 3.01	53.51 \pm 5.09
	6 mph	3.72 \pm 1.33	19.60 \pm 11.20	16.07 \pm 6.52
	10 mph	9.94 \pm 2.25	58.68 \pm 24.95	41.85 \pm 12.85

The largest variations (standard deviation) in mass loading between the three smoke components appeared in the FO samples. This was expected based on results of previous individual component exposures and the volatile nature of the material.

A significant increase of at least 300% in foliar loading was evident in the HC component (Zn) between the 6 and 10 mph exposures (compared with 2 mph), while that of the WP in the pine and sagebrush was much larger (i.e., 600 to 700%). The smallest increases, still greater than 200% were observed in the FO and may again be attributable to the sampling difficulties described above.

Among the four plant species, the lowest overall rates of mass loading for the individual smokes were observed in the grasses, while the highest were found in the pines. These differences may be related to the relative height of the canopy structure between the two species and the pine's correspondingly larger relative profile in the oncoming wind. The

ponderosa pines used for these tests were the tallest species in the exposure chamber, approximately twice as tall as the grasses, which were the shortest.

Following exposure and initial sampling, selected plants (2 each) from each species were placed into a leaching chamber, and their canopies were given a simulated rainfall equivalent to a 0.5-cm rainfall before being sampled (2 subsamples each) a second time for individual smoke components. The material that was left on the leaves is expressed as a percent of the original amount in Table 3.25.

A slight increase was apparent in the mean of foliar retention of all three smoke components with higher mass loading, although the differences did not appear significant (Table 3.25). The percentage retained by the more water-soluble components contained in the HC (Zn) and WP (total P) smokes, were similar in each of the four plant species. The greater retention of the inorganic ions on the surfaces of the pine, sagebrush, and bush bean as opposed to that of the grasses (usually 30 to 50% versus 13 to 18%) were related, in part, to the smoother surfaces of the grass leaves compared with the sagebrush and bean and the presence of resin on the surface of the pine.

The leaching of the fog oil by the simulated rainfall appeared to be slightly less effective. This was probably caused by the hydrophobic nature of the fog oil and its potential for binding to the similarly hydrophobic cuticular material on the surfaces of the leaves. The overall reduction in the mixed-smoke components on the leaf surfaces was mostly likely responsible for the lower phytotoxic responses exhibited by these plants (see Table 3.36.) Overall, foliar leaching of mixed-smoke constituents is generally similar to the leaching losses observed for individual smokes (P, FO, HC), and so synergistic efforts are noted (Van Voris et al. 1987; Cataldo et al. 1989a, 1989b).

TABLE 3.25. PERCENT FOLIAR RETENTION OF MIXED-SMOKE COMPONENTS FOLLOWING A POST-EXPOSURE LEACHING/SIMULATED RAINFALL^(a) IN MS RF/WS TESTS

Species	Wind Speed	% Foliar Retention		
		HC-Zinc	WP-Phosphorus	Fog Oil
			(% ± s.d., n=4)	
Ponderosa Pine	2 mph	13.74 ± 4.26	12.16 ± 3.35	4.92 ± 4.74
	4 mph	13.72 ± 1.69	19.04 ± 10.63	61.20 ± 17.01
	6 mph	39.65 ± 9.18	67.48 ± 18.11	52.90 ± 22.84
	10 mph	51.78 ± 20.83	48.50 ± 19.66	65.01 ± 30.14
Sagebrush	2 mph	34.14 ± 12.60	34.67 ± 13.12	73.89 ± 8.43
	4 mph	43.38 ± 24.68	41.80 ± 24.33	44.90 ± 34.69
	6 mph	38.13 ± 12.75	34.07 ± 13.05	85.60 ± 19.58
	10 mph	59.51 ± 21.73	52.52 ± 19.69	61.19 ± 9.41
Bush Bean	2 mph	40.00 ± 7.27	35.49 ± 10.57	27.33 ± 23.73
	4 mph	34.23 ± 11.62	32.89 ± 14.17	49.70 ± 26.17
	6 mph	34.11 ± 11.52	29.99 ± 9.06	57.10 ± 15.18
	10 mph	50.90 ± 21.52	39.58 ± 19.25	59.37 ± 16.82
Tail Fescue	2 mph	16.33 ± 11.88	16.11 ± 14.38	69.70 ± 9.49
	4 mph	17.09 ± 8.72	16.41 ± 7.40	66.30 ± 10.93
	6 mph	14.70 ± 7.04	13.92 ± 6.61	80.40 ± 18.47
	10 mph	18.46 ± 12.41	17.92 ± 16.59	48.59 ± 8.80

^(a) Leaching/simulated rainfall was conducted within 2 h of contamination and consisted of 350 mL of synthetic rainwater passed through the canopy over a 15-min period and is equivalent to a 0.5-cm rainfall.

Deposition Velocities of Mixed-Smoke Components to Vegetation in the RF/WS Tests

Deposition velocities (V_d) provide a basis for estimating the transfer of smoke constituents from air to foliar and/or soil surfaces, and for specified conditions such as wind speed, particle size distribution, and relative humidity, and is independent of air concentration and exposure duration. Deposition velocities for each of the smoke components to vegetation in the RF/WS Tests are given in Table 3.26. The results, reflecting the mass loading values, once again indicate significant increases with increasing wind speed, particularly between the 6 and 10 mph wind speeds. For ponderosa pine, which exhibited an overall greater collection efficiency, values for V_d with increasing wind speed ranged from 0.003 to 0.40 cm/s for HC, and 0.01 to greater than 0.30 cm/s for WP and FO. Sagebrush had V_d values slightly less overall than the pine. These ranged from 0.003 to 0.07 cm/s for HC at 2 and 10 mph, respectively; for WP and FO, V_d values ranged from 0.01 to 0.20 cm/s as wind speed increased.

TABLE 3.26. DEPOSITION VELOCITIES (V_d) OF Zn (HC), PHOSPHOROUS (WP) AND FOG OIL (FO) TO VEGETATION FROM MIXED-SMOKE RF/WS TESTS

Species	Wind Speed	Foliar Deposition Velocities		
		HC-Zinc	WP-Phosphorus	Fog Oil
(cm/s x 10 ³ ± s.d., N=6)				
Ponderosa Pine	2 mph	3.74 ± 0.44	9.03 ± 1.02	11.98 ± 11.58
	4 mph	4.58 ± 0.51	14.17 ± 7.49	183.23 ± 67.36
	6 mph	6.92 ± 1.13	60.98 ± 23.11	143.45 ± 28.40
	10 mph	41.44 ± 10.44	443.68 ± 134.76	331.17 ± 133.39
Sagebrush	2 mph	3.08 ± 0.63	7.19 ± 1.56	15.19 ± 7.62
	4 mph	7.80 ± 0.85	16.18 ± 2.08	7.45 ± 7.38
	6 mph	12.13 ± 2.67	33.96 ± 7.76	81.59 ± 24.89
	10 mph	70.75 ± 22.61	222.78 ± 126.14	180.14 ± 74.10
Bush Bean	2 mph	1.83 ± 0.32	4.96 ± 1.21	5.91 ± 5.1
	4 mph	4.26 ± 0.91	13.00 ± 3.04	17.81 ± 6.33
	6 mph	7.06 ± 1.59	30.18 ± 7.60	38.84 ± 13.14
	10 mph	23.50 ± 16.53	82.78 ± 53.74	60.67 ± 35.37
Tall Fescue	2 mph	1.52 ± 0.28	4.59 ± 0.93	3.34 ± 0.93
	4 mph	4.59 ± 1.84	6.27 ± 1.73	30.83 ± 2.93
	6 mph	2.14 ± 0.76	11.29 ± 6.45	60.67 ± 35.37
	10 mph	5.72 ± 1.29	33.82 ± 14.37	24.11 ± 7.40

Increased V_d values were also observed for bush bean, although increases with wind speed are not as pronounced. These increases in V_d were not as pronounced for tall fescue, particularly in the case of HC components. It should be noted that the patterns and values obtained for each of the species were comparable to those obtained for the individual components in previous wind speed tests (Van Voris et al. 1987; Cataldo et al. 1989a, 1989b).

Figures 3.9 and 3.10 provide regression plots for the deposition velocity data tabulated in Table 3.26. As wind speed is increased, values of V_d increase exponentially. Generally, a good regression fit of the data is obtained for each plant species, with overall deposition or collection efficiency being ponderosa pine > sagebrush > bush bean > tall fescue. The least significant regression fits are obtained for the fog oil. This likely results from interference of HC organic components with the fog oil assay.

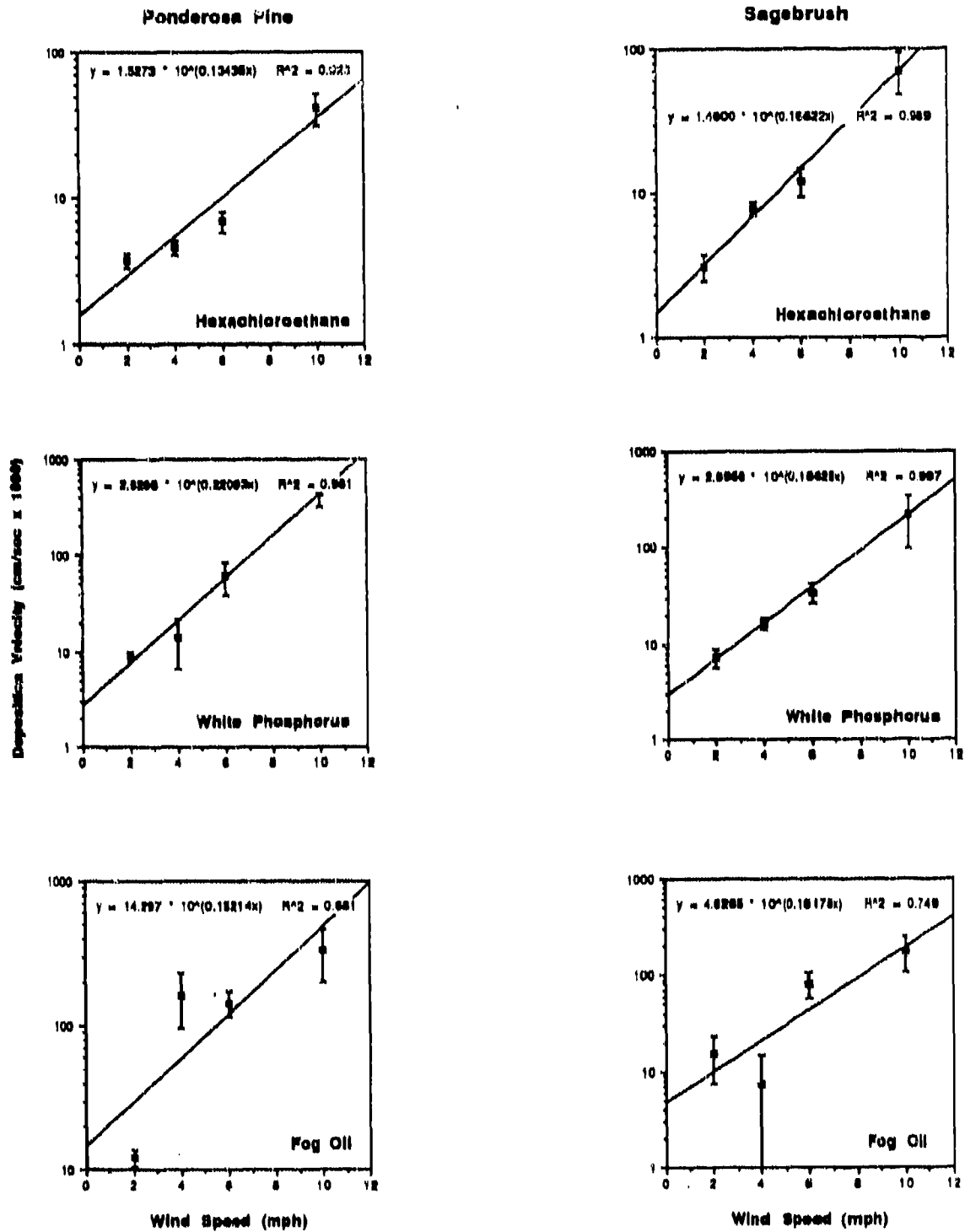

FIGURE 3.9. REGRESSION ANALYSIS OF DEPOSITION VELOCITIES FOR PONDEROSA, PINE AND SAGEBRUSH

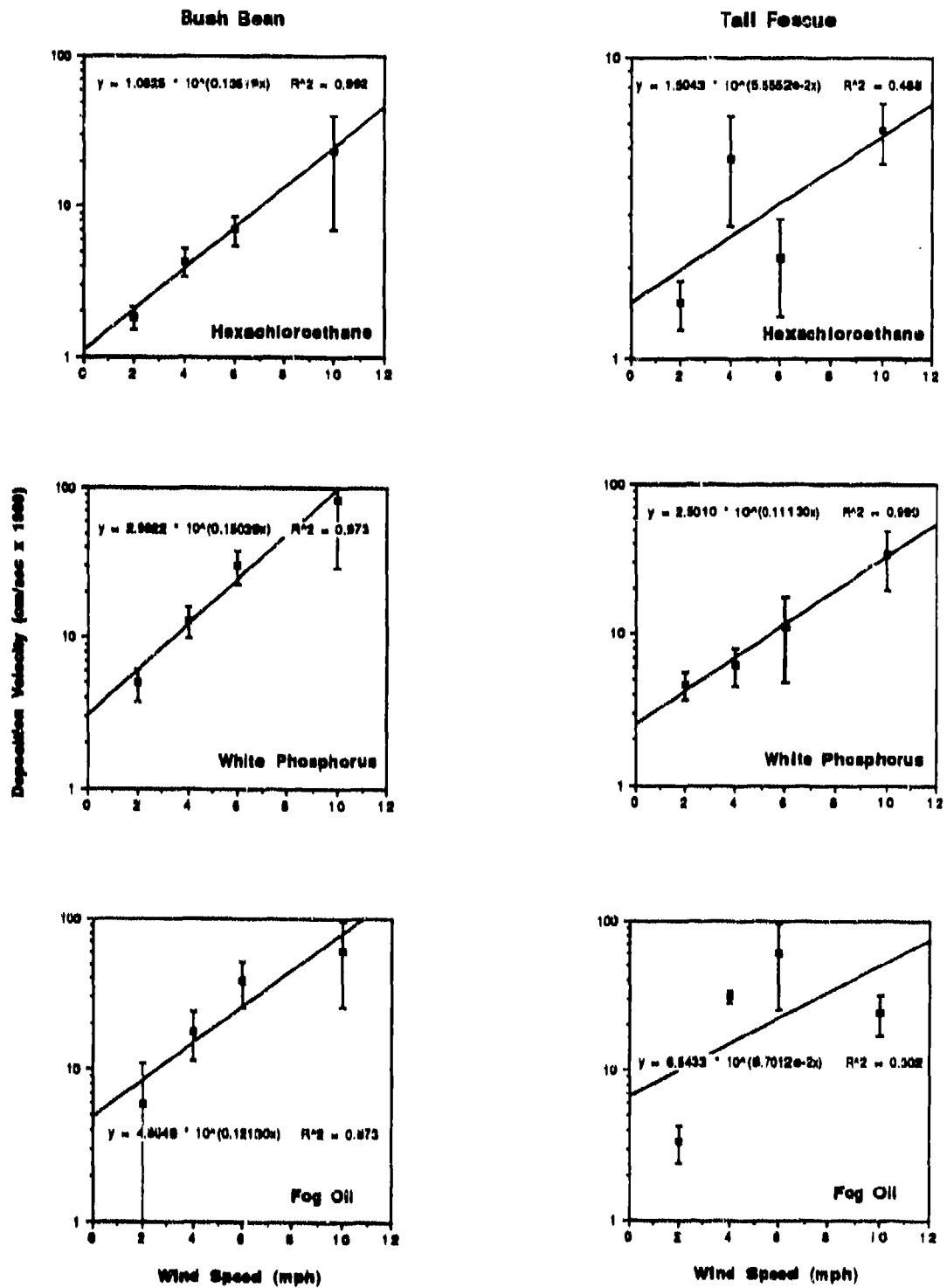

FIGURE 3.10. REGRESSION ANALYSIS OF DEPOSITION VELOCITIES FOR BUSH BEAN AND TALL FESCUE

Follar Mass Loading and Deposition Velocities of Mixed-Smoke Components to Vegetation Following Cumulative Dose Exposures.

Several mixed-smoke, cumulative-dose test scenarios were performed. These included HC/WP with minimal FO (MS-7-8), HC/WP/FO (MS-9-10), FO alone for ML verification (MS-13), WP/FO (MS-14-15), and HC/FO (MS-16-17). Conditions for the cumulative dose (CD) series of exposures were chosen to simulate recurrent field use of mixed smokes. Also, during this test series, rates of mass loading to vegetative surfaces were substantially higher after four exposures than those attained in the 6 to 10 mph treatments in the WS/RFT series. Experimental conditions consisted of an exposure duration of 7 h with a wind speed of 4 mph (1.8 m/s), at 50% RH and 21°C. Target concentrations of the smoke components were: HC ~600 mg/m³, to be generated first, FO ~600 mg/m³ second, and WP ~2000 mg/m³ last.

The initial CD series (MS-7 and MS-8), employing HC, WP, and FO was terminated after two exposures when substantial phytotoxic effects were observed, and it was learned that a faulty feed pump for the FO had caused a substantially lower concentration to be deposited than was projected. Thus, test series MS-7-8 can be considered a HC/WP only test. A subsequent series was initiated with a repaired FO generator, but was again terminated after only two exposures (MS-9-10) when greater-than-expected plant effects were once again observed. Because of these unexpected levels of phytotoxicity, a separate exposure (MS-13), consisting of only FO at the concentration projected for a single CD test, was also performed to provide a more accurate estimation of loading and phytotoxic/physiological effects of the fog oil without analytical interferences from other MS components. The results from the separate FO exposure (MS-13) represent the dosage and effects resulting from a single exposure at the concentration level projected from a single CD exposure and should be interpreted accordingly.

Follar mass loading for the HC and WP components in the two CD series is given in Table 3.27. There appeared to be an elevated deposition of WP in the pines and sagebrush (~200 µg/cm²), compared with other species. Tall fescue had the lowest mass loading, at ~30 µg/cm². For HC smokes, mass loading to all species except fescue ranged from 15 to 30 µg/cm²; ML rates were lower for fescue, 6 µg/cm². The taller stature of the pines as opposed to the other species may have been important in the interception of the larger WP particles from the wind stream, thus accounting for the higher rates of loading. Conversely, the smaller diameter HC particles may have been trapped by the rougher surface morphology (wax plates and leaf hairs) of the sagebrush leaves. The rates of loading following the two exposures in each series, which were within the desired ranges, were greater than those of the 6 mph, but less than those of the 10 mph treatments in the WS/RFT series.

TABLE 3.27. AVERAGE FOLIAR MASS LOADING ($\mu\text{g}/\text{cm}^2$) OF PHOSPHOROUS (WP) AND ZINC (HC) ON VEGETATION SURFACES DURING MIXED-SMOKE/CUMULATIVE DOSE (MS/CD) EXPERIMENTS (MS-7, MS-8, MS-9, AND MS-10) (n = 6, UNLESS NOTED)

Test/ Species	Phosphorous (WP)	Zinc (HC)
	$\mu\text{g}/\text{cm}^2 \pm \text{s.d.}(n=6)$	
MS-7-8		
Ponderosa Pine	209.05 \pm 58.65	19.03 \pm 2.03
Short-Needle Pine	153.71 \pm 61.96	17.90 \pm 4.69
Sagebrush	87.84 \pm 10.09	22.75 \pm 3.87
Bush Bean	94.58 \pm 24.63	16.53 \pm 4.75
Tall Fescue	36.01 \pm 7.44	6.64 \pm 1.59
MS-9-MS-10		
Ponderosa Pine	107.09 \pm 19.05	14.10 \pm 1.23
Short-Needle Pine	214.09 \pm 33.75	22.54 \pm 5.56 ^a
Sagebrush	140.98 \pm 45.52	30.55 \pm 4.54 ^b
Bush Bean	59.28 \pm 30.14	13.06 \pm 4.84
Tall Fescue	28.09 \pm 2.55	6.24 \pm 0.76

(b) n = 2.

Foliar mass loading for FO following a single exposure (MS-13, Table 3.28) exhibited a similar pattern to that of the other MS components. Rates were higher in the pines and sagebrush (110 to 190 $\mu\text{g}/\text{cm}^2$, for a single exposure), and lowest in the grass and bush bean (32 and 75 $\mu\text{g}/\text{cm}^2$, respectively). Once again, the concentrations observed indicated that for the two exposure series, MS-9-10, the expected FO concentrations were similar to the 6 to 10 mph WS/RFT series.

TABLE 3.28. AVERAGE FOLIAR MASS LOADING ($\mu\text{g}/\text{cm}^2$) OF FOG OIL (FO) FOLLOWING AN EXPOSURE (MS-13) SIMULATING THE CONDITIONS OF THE FOG OIL PORTION OF THE COMBINED MS/CD TESTS (n = 4)

Species	Fog Oil (FO)
	($\mu\text{g}/\text{cm}^2$) \pm s.d. (n=4)
Ponderosa Pine	190.03 \pm 22.83
Short-Needle Pine	158.37 \pm 74.94
Sagebrush	111.30 \pm 14.23
Bush Bean	74.76 \pm 16.43
Tall Fescue	31.78 \pm 14.74

Deposition Velocities (V_d) to Vegetation for Mixed-Smoke Components in Cumulative-Dose Test Series.

The V_d values calculated for mixed-smoke cumulative dose series are shown in Table 3.29. Fog oil values could not be determined for HC/WP/FO runs (MS-9-MS-10, two sequential exposures with a 2-day interval), because of interference from organics contained in the other two smokes and loss of hydrocarbons resulting from evaporation from surfaces (Cataldo et al. 1989a). The V_d values for FO were determined independently in test MS-13 (single exposure). Tall fescue and bush bean exhibited the lowest overall V_d values, while the pines and sagebrush exhibited the highest values for each of the three smokes. This pattern was generally similar to that observed in the WS/RFT tests and that previously obtained for the individual components (Van Voris et al. 1987; Cataldo et al. 1989a, 1989b). Thus, there appears to be no synergistic effects of previously disposed smokes or deposition of subsequent samples.

Variations in V_d values between replicate tests were not significant ($P > 0.5$) for HC. Significant variations between runs were observed only for the ponderosa pine exposure with WP ($P > 0.1$). The latter may be related to differences in particle MMAD for the two runs, which may have resulted from the burn rates of the WP.

TABLE 3.29. DEPOSITION VELOCITIES OF Zn (HC), PHOSPHOROUS (WP), AND FOG OIL (FO) TO VEGETATION FROM MIXED-SMOKE CUMULATIVE DOSE AND SPECIAL FOG OIL TESTS

Species	Test	Foliar Deposition Velocities		
		HC-Zinc	WP-Phosphorous	Fog Oil
(cm/sec x 10 ³ ± s.d., n=6(a))				
Ponderosa Pine	MS 7-8	2.74 ± 0.29	30.11 ± 2.74	-
	MS 9-10	2.09 ± 0.17	15.42 ± 2.74	-
	MS 13	-	-	54.75 ± 6.57(b)
Short-Needle Pine	MS 7-8	2.57 ± 0.67	22.14 ± 8.92	-
	MS 9-10	3.24 ± 0.80(c)	30.84 ± 4.86	-
	MS 13	-	-	45.63 ± 21.59
Sagebrush	MS 7-8	3.27 ± 0.55	12.20 ± 1.45	-
	MS 9-10	4.40 ± 0.65(d)	20.31 ± 6.55	-
	MS 13	-	-	32.07 ± 4.12
Bush Bean	MS 7-8	2.38 ± 0.68	13.62 ± 3.54	-
	MS 9-10	1.88 ± 0.69	8.54 ± 4.34	-
	MS 13	-	-	21.54 ± 4.73
Tall Fescue	MS 7-8	0.95 ± 0.22	5.18 ± 1.07	-
	MS 9-10	0.89 ± 0.11	4.05 ± 0.36	-
	MS 13	-	-	9.16 ± 4.24

(a) Unless noted.

(b) n = 4.

(c) n = 5.

(d) n = 2.

Alternate Mixed-Smoke Exposure Scenarios

The greater-than-expected phytotoxic effects following only two exposures to the combined mixed HC/WP and HC/WP/FO smoke scenarios in the CD series prompted additional exposure scenarios to be undertaken. This was based on ML rates and that the FO was expected to add a protective barrier to the foliar absorption of the other smoke constituents. Because individual exposures under similar conditions had already been performed, and resulted in slightly less plant damage, it was assumed that a synergistic effect between two or more of the smokes may be occurring. Therefore, a test series with either WP/FO (MS-14-15) or HC/FO (MS-16-17), consisting of two sequential exposures similar in design to the original CD tests, was performed. The mass loading data given in Tables 3.30 (WP/FO) and 3.31 (HC/FO) do not include the FO component for the same reasons given in the

previous section. It was calculated that the exposure rate, because it was applied under the same conditions, would be twice that of the individual FO exposure (MS-13, Table 3.28), or 60 to 400 $\mu\text{g}/\text{cm}^2$.

As can be seen in Table 3.30, mass loading to plant surfaces ranged from 36 to 679 $\mu\text{g P}/\text{cm}^2$ foliage; actual combusted WP loading would be four times these values for phosphorus. Sagebrush had the highest mass loading, followed by short-needle pine and ponderosa pine, with bush bean and fescue having the lowest loading. The denser aggregation of needles in the short-needle pine canopy and the larger size of the WP particle may have accounted for part of the increased loading compared with the ponderosa pine in the MS-7-8 and MS-9-10 tests. The highest mass loading occurred on the sagebrush with roughly 4 to 6 times that of the previous CD runs. This was attributed in part to the presence of larger and thinner ephemeral spring leaves on the plants during these exposures, which presented a greater profile to the smoke during the exposures. The WP mass loading values for both the bush bean and the tall fescue were also comparable to the previous CD exposures (Table 3.27 versus Table 3.30) because their basic canopy structure remained the same.

TABLE 3.30. AVERAGE FOLIAR MASS LOADING ($\mu\text{g}/\text{cm}^2$) OF PHOSPHOROUS (WP) ON VEGETATION SURFACES DURING MIXED-SMOKE CUMULATIVE DOSE (MS/CD) EXPERIMENTS (14-15) (n = 6)

Species	Phosphorous (WP)
$\mu\text{g}/\text{cm}^2 \pm \text{s.d.}(n=6)$	
Ponderosa Pine	220.26 \pm 39.7
Short-Needle Pine	472.63 \pm 61.96
Sagebrush	679.04 \pm 342.36
Bush Bean	65.75 \pm 29.74 ^(a)
Tall Fescue	36.01 \pm 7.44

^(a) Exposed only to test MS-14.

Mass loading values in the HC/FO exposures ranged from 6 to 56 $\mu\text{g Zn}/\text{cm}^2$ foliage (Table 3.31). The lowest ML rates were again in bush bean and tall fescue. It should also be noted the the rates given for the beans are from a single exposure, which was dictated by the

plant's phytotoxic responses as described below. Sagebrush had the highest mass loading levels, followed by ponderosa pine and short-needle pine, with mass loading rates of 56, 38, and 20 $\mu\text{g Zn/cm}^2$, respectively. The loading value for the sagebrush was again higher and appeared dependent on the newer types of ephemeral leaves, while those of the grass and the bean were comparable to the previous experiments. As noted earlier (p. 3.64), there is no indication that previously applied smokes have any synergistic effect on the mass loading of subsequent smokes.

TABLE 3.31. AVERAGE FOLIAR MASS LOADING ($\mu\text{g/cm}^2$) OF ZINC (HC) ON VEGETATION SURFACES DURING MIXED-SMOKE CUMULATIVE DOSE (MS/CD) EXPERIMENTS (16-17) (n = 6)

Species	Zinc (HC)
$\mu\text{g/cm}^2 \pm \text{s.d.} (n = 6)$	
Ponderosa Pine	37.81 ± 7.54
Short-Needle Pine	19.87 ± 4.16
Sagebrush	56.56 ± 17.80
Bush Bean	$6.18 \pm 2.27^{(a)}$
Tall Fescue	6.88 ± 1.30

(a) Exposed only to MS-14.

3.3.2 Mass Loading of Mixed-Smoke Constituents to Exposed Soils

Soils were exposed to mixed smokes to assess subsequent impacts on plant growth, microbial metabolism, and soil invertebrates (earthworms). Exposed soils were analyzed for deposited smoke constituents based on Zn, total P, and fog oil hydrocarbons. These values then established the dose relationships for subsequent biotic effects studies.

Range-Finding/Wind Speed Test Series

Soil mass loading values for each of the mixed smoke constituents from the RFT/WS test series are provided in Table 3.32. Except for HC smoke, there is considerable variation in

deposition rates for the smokes. There were no significant correlations between increasing wind speed and mass loading of the exposed soil coupons. This is understandable because the portion of the test section ahead of the plants has stable, low turbulence air flow; thus, deposition to flat soil surfaces lying within the boundary layer, would depend more on sedimentation rates than impaction, as with the plant canopies. Also, no differences in mass loading were observed between the two soil types, Burbank and Maxey Flats.

TABLE 3.32. SOIL MASS LOADING FOR BURBANK AND MAXEY FLATS SOILS FOLLOWING EXPOSURE TO MS RF/WS TESTS

Soil Type	Wind Speed	Soil Mass Loading		
		HC-Zinc	RP-Phosphorous	Fog Oil
($\mu\text{g}/\text{cm}^2 \pm \text{s.d.}, n=3$)				
Burbank	2 mph	6.64 \pm 0.86	15.53 \pm 1.97	126.17 \pm 114.08
	4 mph	5.40 \pm 0.45	6.32 \pm 1.36	267.18 \pm 52.51
	6 mph	5.43 \pm 0.51	13.23 \pm 1.50	48.34 \pm 0.31
	10 mph	9.71 \pm 0.98	11.86 \pm 3.24	233.00 \pm 28.32
Maxey Flats	2 mph	11.81 \pm 0.43	6.26 \pm 0.21	194.78 \pm 181.30
	4 mph	7.92 \pm 0.89	34.63 \pm 2.64	108.10 \pm 51.97
	6 mph	9.12 \pm 1.39	10.40 \pm 3.01	44.57 \pm 5.42
	10 mph	8.82 \pm 0.81	5.91 \pm 3.86	222.19 \pm 0.36

Mixed-Smoke Cumulative Dose Test Series

As noted earlier, the mixed-smoke cumulative dose test scenarios included HC/WP with minimal FO (MS-7-8), HC/WP/FO (MS-9-10), FO alone for mass loading verification (MS-13), WP/FO (MS-14-15), and HC/FO (MS-16-17). Soil mass loading rates, following a 2-h exposure to each smoke at 4 mph wind speeds are provided in Table 3.33. Mass loading rates to each of the three soils was comparable for WP and HC in the two test series (MS-7-8, MS-9-10), and ranged from 4 to 20 $\mu\text{g P}/\text{cm}^2$ soil, and 2 to 20 $\mu\text{g Zn}/\text{cm}^2$ soil following WP and HC deposition. Fog oil loading, based on MS-13 results ranged from 9 to 15 $\mu\text{g}/\text{cm}^2$ for the three soils. WP deposition was highest in Burbank soil, followed by Palouse and lowest in Maxey Flats. Deposition patterns were different for the HC aerosols, with Maxey Flats and Burbank having the highest mass loading levels and Palouse the lowest.

TABLE 3.33. AVERAGE SOIL MASS LOADING ($\mu\text{g}/\text{cm}^2$) OF PHOSPHOROUS (WP) AND ZINC (HC) DURING MIXED-SMOKE CUMULATIVE DOSE (MS/CD) EXPERIMENTS (MS-7-8 AND MS-9-10) (N = 3), AND AVERAGE SOIL MASS LOADING ($\mu\text{g}/\text{cm}^2$) OF FOG OIL (FO) DURING SEPARATE FOG OIL EXPOSURE AS PART OF THE MS/CD EXPOSURES (MS-13) (n = 3)

Test/ Soil Type	Phosphorous (WP)	Zinc (HC)	Fog Oil (FO)
$\mu\text{g}/\text{cm}^2 \pm \text{s.d. (n = 3)}$			
MS-7-8			
Maxey Flats	4.40 \pm 0.2	18.95 \pm 1.87	-
Burbank	23.00 \pm 2.95	10.21 \pm 0.64	-
Palouse	8.93 \pm 1.12	2.26 \pm 0.03	-
MS-9-10			
Maxey Flats	4.35 \pm 0.13	20.66 \pm 1.30	-
Burbank	21.20 \pm 2.07	15.48 \pm 2.68	-
Palouse	10.23 \pm 0.48	2.78 \pm 0.30	-
MS-13			
Maxey Flats	-	-	9.82 \pm 0.68
Burbank	-	-	9.30 \pm 0.57
Palouse	-	-	14.82 \pm 1.53

Mass loading rates for soils from mixed-smoke scenarios employing WP/FO and HC/FO are shown in Tables 3.34 and 3.35. Fog oil mass loading levels were not measured directly, but should be comparable to those provided in Table 3.31. For WP smoke, deposition rates ranged from 3 $\mu\text{gP}/\text{cm}^2$ soil for Cinebar, to 109 $\mu\text{gP}/\text{cm}^2$ for Burbank soil. These values are substantially higher than those seen in the HC/WP/FO CD test, and may be related to the larger particle size distributions of the aerosol. In the HC/FO tests, HC loading ranged from 3 $\mu\text{gZn}/\text{cm}^2$ soil for Palouse and Cinebar soils, to 26 $\mu\text{g}/\text{cm}^2$ soil in Maxey Flats soil. In this instance, deposition was comparable to that seen in the HC/WP/FO test series.

TABLE 3.34. AVERAGE SOIL MASS LOADING ($\mu\text{g}/\text{cm}^2$) OF PHOSPHOROUS (WP) DURING MIXED-SMOKE CUMULATIVE DOSE (MS/CD) EXPERIMENTS (14-15) (n = 3)

Soil Type	Phosphorous (WP)
	$\mu\text{g}/\text{cm}^2 \pm \text{s.d. (n=3)}$
Maxey Flats	44.35 \pm 2.46
Burbank	109.53 \pm 8.54
Palouse	46.22 \pm 2.25
Cinebar	3.11 \pm 0.54

TABLE 3.35. AVERAGE SOIL MASS LOADING ($\mu\text{g}/\text{cm}^2$) OF ZINC (HC) DURING MIXED-SMOKE CUMULATIVE-DOSE (MS/CD) EXPERIMENTS (16-17) (n = 3)

Soil Type	Zinc (HC)
	$\mu\text{g}/\text{cm}^2 \pm \text{s.d. (n=3)}$
Maxey Flats	26.40 \pm 1.43
Burbank	19.17 \pm 4.25
Palouse	2.72 \pm 0.48
Cinebar	3.70 \pm 1.00

3.3.3 Contact Phytotoxicity of Mixed Smokes Deposited to Follar Surfaces

The results of previous studies dealing with aerosol characterization and mass loading of smoke constituents to surfaces are employed to establish the dose conditions for further evaluation of environmental impacts. Several environmental parameters, including wind speed and relative humidity, and exposure conditions such as smoke type, combinations of

smoke, and also the quantity of smoke constituents deposited to biotic surfaces and/or biotic zones can influence the environmental effects of obscurant smokes.

The following contact toxicity studies are designed to establish the relationship between foliar mass loading and phytotoxicity arising from direct contact of smoke constituents with foliage. In these studies, the soil container is bagged to prevent contamination of soil, thus allowing evaluation of only foliar contact toxicity. The indirect effects of mixed smoke on plants, via soil contamination, are addressed in Section 3.3.4.

Dealing with the foliar contact toxicity problem presents several problems. First, in the present study three of the five plant species are natural genetic stock, and each individual can represent a slightly different genotype. This results in some degree of physiological variability, and thus, possible toxicity response differences within each test species. Second, under both field conditions and wind tunnel simulations, where air movement occurs along a given vector (i.e., wind direction), deposition to canopies can occur irregularly depending on canopy structure, density, and the presence of back eddies. These air movements and currents account for a substantial fraction of the foliar deposition in both instances and are real world conditions. However, this dynamic exposure approach is substantially more suited to toxicity testing than stirred or unstirred static exposure systems. The third problem, taking for granted natural variability in test species and foliar deposition patterns, is how to quantitate damage to vegetation in a consistent and cost-effective manner. After preliminary results with RP smokes were obtained (Van Voris et al. 1987), it was decided that the best approach to evaluating contact toxicity was to use a non-parametric grading system, namely, a modification of the Daubenmire (1959) rating scale as a damage index.

The modified Daubenmire rating scale (MDRS) and descriptors for toxicity symptoms were given in Table 2.10 and used to describe the toxicity responses in each of the following studies. The MDRS is used to describe the extent of visual damage caused by the HC smoke delivered under different experimental conditions. This can be any one, or more, of the listed symptoms; however, for the HC smoke, the major effects appeared to be tip burn and chlorosis. In the case of the pines, grass, and in some instances sagebrush, the intensity of foliar damage was further quantitated by determination of the physical length of needle or leaf damage. It should be restated that the data generated for foliar contact toxicity are non-parametric and represent an estimate of foliar damage. The physiological data (photosynthesis and respiration), collected for selected test series, are used to correlate the visual symptoms with actual metabolic responses to the exposure, and should be considered together in evaluating actual vegetation effects.

Phytotoxicity Observed Following Range-Finding/Wind Speed Exposures

Phytotoxic response to the initial mixed-smoke tests, wind speed tests (MS-3 through MS-6, Table 3.36), was less than expected based on previous results with the WP (Van Voris et al. 1987) and HC (Cataldo et al. 1989b) applied individually. These results can be attributed to the lower mass loading rates (Table 3.24). For example, WP was deposited with doses ranging from 15 to 770 $\mu\text{g P/cm}^2$; DR toxicity ratings ranged from 1.5 to 5.5 (minimal to severe) at 3 weeks post-exposure. Previous studies with WP alone (Van Voris et al. 1987) showed toxicity ratings to range from 2 to 6 for ponderosa pine at mass loading levels of 7 to 1200 $\mu\text{g P/cm}^2$, respectively. Also, HC loading in the MS-3-6 tests ranged from 7 to 72 $\mu\text{g Zn/cm}^2$ that, based on earlier single smoke exposures for HC (Cataldo et al. 1989b) should have resulted in additional damage, which was not observed. In these earlier studies, DR toxicity ratings ranged from 1 to 2.5 for mass loadings of 4 to 143 $\mu\text{g Zn/cm}^2$. Little or no toxicity would have been expected for the FO deposited to foliar surfaces based on the present mass loading

TABLE 3.36. PLANT SYMPTOMOLOGY TO MIXED-SMOKE EXPOSURES IN WIND SPEED TESTS MS-3 THROUGH MS-6. DETERMINATIONS WERE MADE WITHIN 48 h OF INITIAL EXPOSURE AND AFTER THREE WEEKS ON BOTH THE EXPOSED AND EXPOSED-LEACHED PLANTS

Species/ Treatment(b) Sampling Time	Toxicity Response(a)	
	Damage Index (DR Scale)	Symptomology
Bush Bean		
MS-3, 2 mph		
Initial	2.0	chl, NS
3 Weeks	3.5	chl, NS, LC, TB, NGDH
Leached, 3 Weeks	2.0	NS, TB
MS-4, 4 mph		
Initial	2.0	chl, NS
3 Weeks	4.0	chl, NS, LC, TB, NGDH
Leached, 3 weeks	3.5	NS, TB
MS-5, 6 mph		
Initial	4.0	W, NS
3 Weeks	4.0	chl, LD, NS, OGA
Leached, 3 Weeks	4.0	chl, LD, NS, OGA
MS-6, 10 mph		
Initial	5.5	W, NS, TB
3 Weeks	5.5	LBD, chl, NS, O&NGA
Leached, 3 Weeks	3.5	LBD, chl, NS, O&NGA

TABLE 3.36. (Cont.)

Species/ Treatment/(b) Sampling Time	Toxicity Response(a)	
	Damage Index (DIR Scale)	Symptomology
Sagebrush		
MS-3, 2 mph		
Initial	0	
3 Weeks	2.0	TB(0.5), BD, OGA
Leached, 3 Weeks	1.0	TB(0.5)
MS-4, 4 mph		
Initial	0	
3 Weeks	2.0	TB(0.5), BD, OGA
Leached, 3 Weeks	1.0	TB(0.5)
MS-5, 6 mph		
Initial	0	
3 Weeks	3.0	BD, TB(0.5), LD, OGA
Leached, 3 Weeks	1.0	BD
MS-6, 10 mph		
Initial	4.0	BD, OGA
3 Weeks	5.5	BD, O&NGA
Leached, 3 Weeks	5.0	BD, O&NGA
Ponderosa Pine		
MS-3, 2 mph		
Initial	1.0	
3 Weeks	1.5	TB(0.5), NS
Leached, 3 Weeks	1.0	TB(1.5)
MS-4, 4 mph		
Initial	1.0	
3 Weeks	1.5	TB(1.0), NS
Leached, 3 Weeks	1.0	TB(1.5)
MS-5, 6 mph		
Initial	1.5	TB(1.0)
3 Weeks	2.0	NS, TB(1.0), OGA
Leached, 3 Weeks	1.0	NS
MS-6, 10 mph		
Initial	4.5	NS, TB(2.0)
3 Weeks	5.5	LBD, NS, O&NGA, LD
Leached, 3 Weeks	2.5	NS, TB(4.0), OGA
Tall Fescue		
MS-3, 2 mph		
Initial	1.0	NS
3 Weeks	1.5	TB(0.5), NS, LC
Leached, 3 Weeks	1.0	TB(0.5), NS, LC
MS-4, 4 mph		
Initial	1.0	
3 Weeks	1.5	TB(4.0), NS, LC, OGA
Leached, 3 Weeks	1.0	TB(1.5), LC, OGA
MS-5, 6 mph		
Initial	3.0	TB(8.0), NS, W, OGA
3 Weeks	3.5	TB(10.0), NS, W, OGA
Leached, 3 Weeks	2.0	TB(4.0), W, NS, OGA

TABLE 3.36. (Cont.)

Species/ Treatment ^(b) Sampling Time	Toxicity Response ^(a)	
	Damage Index (DR Scale)	Symptomology
Tall Fescue (cont.)		
MS-6, 10 mph		
Initial	4.5	NS, TB(10.0), W, OGA
3 Weeks	5.5	NS, OGA, TB(13.0), W
Leached, 3 Weeks	5.5	NS, TB(10.0.0), OGA, W

(a) Daubermire scale and symptomology definitions given in Table 2.10.

(b) MS-3-6 employed HC/FCWP.

levels and previous results with single FO smoke exposures (Cataldo et al. 1989a). These comparative results would indicate that, at least for single MS dose events, additive effects from mixed smoke events are not evident and the majority of the effects observed result from WP constituents.

Of the four species exposed in the mixed-smoke wind speed tests, the bush bean proved to be the most sensitive to the materials contained in the smokes (Table 3.36), even though the bush bean received the second lowest dose based on mass loading. Within 48 h, particularly at higher wind speeds, there was significant damage consisting primarily of necrotic spotting and chlorosis in the older exposed surfaces. Within 3 weeks, all the older exposed leaves had aborted. In the lower wind speed experiments (2 and 4 mph), the damage did not include the leaf buds, and the new leaves developed normally post-exposure, while in the higher wind speed experiments (10 mph) the developing buds and new shoot growth were damaged.

The remaining species, tall fescue, sagebrush, and ponderosa pine, did not exhibit significant phytotoxic responses at lower wind speeds. In fact, there appeared to be a definite threshold of responses, particularly for the pine and sagebrush, between the 6 and 10 mph tests (Table 3.26); this corresponded with a dramatic increase in foliar mass loading and damage (DR 5.5). The damage at the highest wind speed appeared to affect the new growth in the sagebrush and pine as well, more so than in the grasses.

Post-exposure leaching, to remove surface contaminants, did not consistently reduce the extent of plant damage. Although leaching removes 10 to 50% of the foliar-deposited HC and WP components (Table 3.25), amelioration of effects was apparent only at wind speeds

below 6 mph. No amelioration was apparent at high wind speeds and higher mass loading levels. Thus, toxicity is likely related to the total amount of material left on the foliage because in most species 10 to 50% of the original material remained on the leaves, and this residual dose may still exceed that required for a damage threshold.

It should be noted that, as in previous single-smoke exposures, old growth is more susceptible to damage than more recent or younger tissues. Damage patterns did not indicate which of the components of the mixture may have proven to be the most phytotoxic. However, the higher incidence of necrotic spotting, particularly immediately after the exposure, and plant wilting (Table 3.36), were more characteristic of white phosphorus damage (Van Voris et al. 1987).

Contact Phytotoxicity to Mixed-Smoke Cumulative Dose Exposures

In the cumulative dose test (CDT), the objective is to determine whether biotic impacts from successive exposures are equivalent to, less, or more severe than those resulting from single exposures having the same total dose (mass loading). This provides essential information as to whether effects are cumulative based on total dose, or whether metabolic compensation occurs in the intervening time between dose events.

Originally, the CDT series was to employ four consecutive exposures at 2- to 3-day intervals. However, because of the extent of plant damage, studies were terminated after the second exposure period. As noted earlier, test series MS-7-8 can be considered a HC/WP only test.

Test series MS-9-10 employed HC/WP/FO. Test MS-13 consisted of only FO at the concentration projected for a single CDT exposure, and was performed to provide a more accurate estimation of loading, and phytotoxic/physiological effects of the fog oil without analytical interferences from the other MS components.

Significant phytotoxic effect was observed within 7 days post-exposure in all species in both of the MS/CD series (MS-7-8 and MS-9-10, Tables 3.37 and 3.38, respectively). In both test series the bush beans were impacted the greatest in the shortest time period (<48 h) with both the old and new growth being affected. The plants showed marked necrotic spotting, leaf curl, and wilting immediately after exposure and continued to do so for the next week (DFI 5.5-6). However, within the second week after the exposures were stopped the meristematic

regions of the plant had recovered sufficiently to initiate new growth, which continued up to the time the plants were terminated (30 days). At 30 days post-exposure damage to bush bean was judged moderate (DR 3).

The other species also showed substantial damage just before and after the second exposure of the CD series. The sagebrush, tall fescue, and pines showed necrotic spotting,

TABLE 3.37. PLANT SYMPTOMOLOGY TO MIXED-SMOKE EXPOSURES IN CUMULATIVE DOSE EXPERIMENTS MS-7-8. THE TWO EXPOSURES WERE MADE AT 48-h INTERVALS, AND SYMPTOMOLOGY DETERMINATIONS WERE MADE AT 2, 7, 14, AND 30 DAYS AFTER THE FIRST EXPOSURE

Species/ Sampling Time	Mass Loading Average P, Zn ML ^(b)	Toxicity Response ^(a)	
		Damage Index	Symptomology
	$\mu\text{g}/\text{cm}^2$	(DR Scale)	
Bush Bean			
2 days	94.58, 16.53	5.5	NS, LC, W, TB, O&NGA
7 days		6.0	LBD, LC, NS, TB, O&NGA
14 days		3.0	LC, NS, TB (1.0), OGA
30 days		3.0	LC, NS, TB (1.5), NGDHC
Ponderosa Pine			
2 days	209.05, 19.03	1.0	NS
7 days		3.0	NS, TB
14 days		3.0	LD, NS, TB (5.5)
30 days		3.5	GD, LD, TB (7.0)
Sagebrush			
2 days	87.04, 22.75	2.0	W, TB (<0.5), LC
7 days		5.0	LBD, W, TB, OGA, Chl
14 days		3.0	BD, TB (<0.5), NGDH
30 days		2.0	BD, TB (<0.5), NGDH
Short-Needle Pine			
2 days	153.71, 17.90	1.0	NS, Chl
7 days		3.5	NS, Chl, TB (3.5), GD, OGA
14 days		3.0	NS, Chl, NGDH
30 days		2.5	NGDH
Tall Fescue			
2 days	36.01, 6.64	2.5	NS, W, TB (5.5)
7 days		4.0	NS, TB (13.0), Chl
14 days		3.0	NS, TB (13.0), Chl
30 days		3.5	NS, TB (15.0), Chl

(a) Daubenmire scale and symptomology definitions; MS-7-8 employed HC/FO/WP.

(b) Average foliar mass loading.

(c) New growth developing healthy.

wilting, and tip burn to various degrees (DR 2 -5). These observations were an important part of the decision to terminate the exposure series at this time. The wilting, similar to that observed in the WS/RFT tests, may be symptomatic of the WP treatment as reported earlier. In CD test series MS-9-10, where FO was employed, effects were not substantially different from the test series without FO to indicate that FO either added to or had any amelioration effects on damage.

TABLE 3.38. PLANT SYMPTOMOLOGY TO MIXED-SMOKE EXPOSURES IN CUMULATIVE DOSE EXPERIMENTS MS-9-10. THE TWO EXPOSURES WERE MADE AT 48-h INTERVALS AND SYMPTOMOLOGY DETERMINATIONS MADE AT 2, 7, 14, AND 30 DAYS AFTER THE FIRST EXPOSURE

Species/ Sampling Time	Toxicity Response ^(a)		Symptomology
	Average P, Zn ML ^(b)	Damage Index	
	$\mu\text{g}/\text{cm}^2$	(DR Scale)	
Bush Bean			
2 days	59.28, 13.06	4.5	NS, LC, W, TB, Chl, O&NGA
7 days		5.5	LBD, LC, TB (0.5), O&NGA
14 days		5.5	LC, NS, BD, TB (1.0), O&NGA
30 days		2.0	NS, NGDH ^(c)
Ponderosa Pine			
2 days	107.09, 14.10	1.0	TB (<0.5)
7 days		2.0	NS, TB (1.5)
14 days		2.0	NS, TB (3.5)
30 days		1.5	TB (3.5)
Sagebrush			
2 days	140.98, 30.55	2.5	W, TB (<0.5), LC
7 days		4.5	LBD, W, TB (<0.5), OGA
14 days		4.0	BD, NS, TB (<0.5), NGDH
30 days		2.0	TB (<0.5), NGDH
Short-Needle Pine			
2 days	214.09, 22.54	1.0	NS
7 days		4.0	NS, TB (3.0), GD, O&NGA
14 days		5.0	NS, TB (6.0), GD
30 days		2.5	TB (6.0), NGDH
Tall Fescue			
2 days	28.09, 6.24	2.0	NS, TB (3.5)
7 days		4.0	NS, TB (6.0), Chl, OGA
14 days		5.0	NS, TB (15.5), Chl, OGA
30 days		4.5	NS, TB (15.5), Chl, OGA

(a) Daubenmire scale and symptomology definition; MS-9-10 employed HC/FO/WP.

(b) Average foliar mass loading.

(c) New growth developing healthy.

Minimal phytotoxic effects were evident on those plants exposed to a single dose of FO in the special run (MS-13, Table 3.39). Again, the bush bean showed the greatest effects, but these were less severe (DR 3-4) than those of the MS exposures, and recovery was noted within the 30 days post-exposure. With the exception of some necrotic spotting and tip burn (>7 cm) in the tall fescue, the other species did not appear to have significant damage (DR 2). These results are comparable to those observed in the previous test series involving FO alone (Cataldo et al. 1989a) and were therefore expected given the amount of foliar mass loading involved.

Given that FO alone (MS-13) does not produce the severe phytotoxic effects observed in the MS-9-10 test series, and that there was not an observable reduction in any phytotoxic effects observed in the initial MS/CD exposures (MS-7-8), where the FO generation was markedly reduced, it was therefore assumed that one of the other two components (WP or HC) might be at fault. This prompted additional CD exposures using the WP/FO (MS-14-15) or the HC/FO (MS 16-17) to verify the absence of either ameliorating or synergistic effects. These latter studies with dual smokes were performed at substantially higher mass loadings to be more consistent with the earlier single smoke exposures involving WP (Van Voris et al. 1987) and HC (Cataldo et al. 1989b).

The results of these additional tests are given below in Tables 3.40 (WP/FO) and 3.41 (HC/FO). Foliar mass loading of WP/P ranged from 66 to 679 $\mu\text{g P}/\text{cm}^2$ in MS-14-15, compared with 4 to 30 $\mu\text{g P}/\text{cm}^2$ in MS-7-10. Foliar mass loading in HC test series MS-16-17 ranged from 6 to 56 $\mu\text{g Zn}/\text{cm}^2$, compared with 1 to 4 $\mu\text{g Zn}/\text{cm}^2$ in MS-7-10. Overall, damage based on the DR rating scale was greater for the WP/FO treatments than the HC/FO treatments.

**TABLE 3.39. PLANT SYMPTOMOLOGY IN FOG OIL EXPERIMENT MS-13.
SYMPTOMOLOGY DETERMINATIONS MADE AT 2, 14, AND 30 DAYS
POST-EXPOSURE**

Species/ Sampling Time	Toxicity Response ^(a)		Symptomology
	Average FO ML ^(b)	Damage Index	
	$\mu\text{g}/\text{cm}^2$	(DR Scale)	
Bush Bean			
2 days	74.76	3.0	NS, LC, W
14 days		4.0	NS, LC, W
30 days		3.0	NS, LC, W, NGDH ^(c)
Ponderosa Pine			
2 days	190.03	1.0	NS
14 days		1.0	NS
30 days		1.0	NS
Sagebrush			
2 days	111.30	1.0	NS
14 days		1.0	NS
30 days		1.0	NS
Short-Needle Pine			
2 days	158.37	1.0	NS
14 days		1.0	NS
30 days		1.0	NS
Tall Fescue			
2 days	31.78	1.0	NS, TB (<0.5)
14 days		2.0	NS, TB (3.5)
30 days		2.0	NS, TB (7.5)

(a) Daubenmire scale and symptomology definitions.

(b) Average foliar mass loading.

(c) New growth developing healthy.

TABLE 3.40. PLANT SYMPTOMOLOGY TO MIXED-SMOKE EXPOSURES IN CUMULATIVE DOSE EXPERIMENTS MS-14-15. THE TWO EXPOSURES WERE MADE AT 48-h INTERVALS, AND SYMPTOMOLOGY DETERMINATIONS WERE MADE AT 2, 8, AND 30 DAYS AFTER THE FIRST EXPOSURE

Species/ Sampling Time	Toxicity Response ^(a)		Symptomology
	Average P ML ^(b)	Damage Index	
	$\mu\text{g}/\text{cm}^2$	(DR Scale)	
Bush Bean			
2 days	66.75 ^(c)	5.0	NS, LC, W, TB, O&NGA
8 days		3.0	LBD, LC, NS, TB, O&NGA
30 days		2.0	LC, NS, NGDH ^(d)
Ponderosa Pine			
2 days	220.26	1.0	NS, TB, NGA
8 days		3.0	NS, TB (1.5), LBD
30 days		2.5	LBD, TB (7.0), NGDH
Sagebrush			
2 days	679.04	3.0	W, TB (<0.5), LC
8 days		5.5	LBD, W TB, OGA
30 days		5.5 ^(e)	BD, TB (<0.5), NGDH
Short-Needle Pine			
2 days	472.63	3.0	W, NS
8 days		5.0	W, NS, TB (3.5), OGA
30 days		2.5	NS, Chl, NGDH
Tall Fescue			
2 days	131.46	3.0	NS, TB (8.5)
8 days		5.0	NS, TB (18.0), Chl
14 days		3.0	NS, TB (22.0), Chl

(a) Daubenmire scale and symptomology definitions; test series MS-14-15 employed FOWP.

(b) Average foliar mass loading.

(c) Exposed only to test MS-14.

(d) New growth developing healthy.

(e) One plant dead.

In the WP/FO tests, bush bean was severely impacted (DR 5), but recovered. Ponderosa pine, short-needle pine, and tall fescue were impacted, but again, showed recovery after 14 to 30 days post-exposure. Sagebrush, which received the highest dose, was severely impacted and did not recover; this may have been because of the spring exposure time when younger leaves were present. Severe wilting was evident in the short-needle pine and sagebrush.

in the HC/FO test series (MS-16-17, Table 3.41), except for bush bean and sagebrush, damage was minimal to moderate (DR 1 to 3). It is important to note that mass loadings in this test series were as much as 25 times higher than those obtained in tests MS-7-10 (Table

TABLE 3.41. PLANT SYMPTOMOLOGY TO MIXED-SMOKE EXPOSURES IN CUMULATIVE DOSE EXPERIMENTS MS-16-17. THE TWO EXPOSURES WERE MADE AT 48-h INTERVALS, AND SYMPTOMOLOGY DETERMINATIONS WERE MADE AT 2, 7, AND 30 DAYS AFTER THE FIRST EXPOSURE

Species/ Sampling Time	Toxicity Response ^(a)		
	Average Zn ML ^(b) µg/cm ²	Damage Index (DR Scale)	Symptomology
Bush Bean			
2 days	6.18 ^(c)	6.0	NS, LC, LBD, TB, Chl, O&NGA
7 days		5.0	LC, TB (0.5), Chl, NS, OGA
14 days		3.0	LC, NS, Chl, OGA
30 days		2.0	NS, NGDH ^(d)
Ponderosa Pine			
2 days	37.81	2.0	TB (6.5), Chl
7 days		2.0	NS, TB (6.5)
14 days		2.0	NS, TB (7.0)
30 days		2.5	TB (3.5), NGDH
Sagebrush			
2 days	56.56	4.0	TB (<0.5), LC
7 days		5.0	LBD, Chl, NS, W, TB, OGA
14 days		4.0	BD, NS, TB (1.0), NGDH
30 days		4.0 ^(e)	W, NS, TB (<0.5), NGDH
Short-Needle Pine			
2 days	19.87	1.0	
7 days		1.0	NS, TB (2.0), O&NGA
14 days		1.5	NS, TB (3.0),
30 days		1.0	TB (3.0), NGDH
Tall Fescue			
2 days	6.88	1.0	NS
7 days		3.5	NS, TB (6.0), Chl, OGA
14 days		3.0	NS, TB (11.5), Chl, OGA
30 days		2.0	NS, TB (16.0), Chl, OGA

(a) Daubenmire scale and symptomology definitions.

(b) Average foliar mass loading.

(c) Exposed only to test MS-16.

(d) New growth developing healthy.

(e) One plant dead.

3.29), yet damage was less. This would suggest that much of the damage observed in the mixed-smoke tests, which included WP, was because of the WP constituents deposited to foliage.

3.3.4 Metabolic Responses to Mixed Smokes Wind Speed Exposures

To determine any potential metabolic effects of the mixed smokes, not evident in the visual phytotoxicity data, additional measurements were performed for two principal metabolic processes, net photosynthesis and respiration. This employed whole plant infrared gas analysis using only two of the plant species, tall fescue and ponderosa pine. To minimize plant-to-plant variability, single plants of each species were sampled before and at various intervals over the 3 weeks following the exposures in each of the experiments.

The results of these measurements for the WS/RFT tests (MS-3-6) are given in Figures 3.11 and 3.12 and are expressed as net $\mu\text{Mol CO}_2/\text{s}$ per plant at specific time intervals. Net CO_2 uptake, or net photosynthesis in the light is considered to be that CO_2 fixed into carbohydrate over and above that lost through respiration and is expressed as a positive value. Dark respiration is a measure of the basal respiration rate, or CO_2 loss, in the absence of fixation and is expressed as a negative value.

The overall metabolic effects in the WS/RFT tests employing HC/WP/FO were less than expected based on the previous exposures to individual mixed-smoke components (Van Voris et al. 1987; Cataldo et al. 1989b), and as expected, based on visual symptomology for these test series. The ponderosa pines were generally in a slow growth condition at the time of exposure (before the spring bud burst), and the whole plant photosynthetic rates were therefore initially low (Figure 3.11a). Absent or reduced fixation in the presence of basic respiration may result in a net photosynthetic rate that has a negative value. This was evident in all the ponderosa pine measurements (Figures 3.11a, b, c, and d) following the exposure. This effect was more prolonged and severe with increasing wind speed and accompanying increases of smoke deposition on the leaf surfaces (Table 3.24). A reduction in photosynthesis was evident in most cases within 72 h following exposure. Apparent recovery from the exposure and regain in photosynthetic rate after 3 weeks was evident primarily in the 2-mph plant (Figure 3.12a) whose mass loading, particularly for WP, was much lower than at higher wind speeds. The 4-mph plant (Figure 3.12b) remained below the net compensation point over the 15 days the measurements were taken, while the 6-mph plant may have indicated a slight recovery after this time (Figure 3.12c). Net photosynthesis appeared to have been entirely lost in the 10-mph plant (Figure 3.12d), which also suffered the most extensive

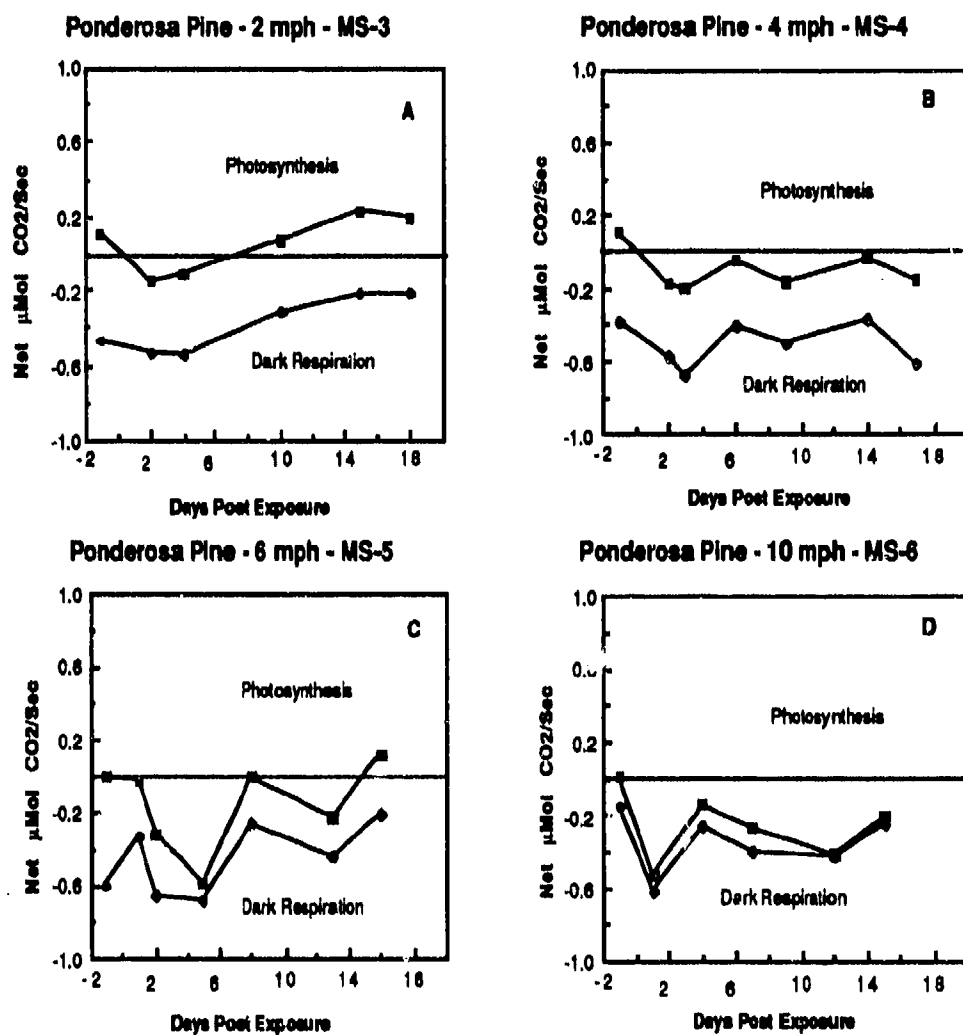

FIGURE 3.11. NET PHOTOSYNTHESIS AND DARK RESPIRATION IN $\mu\text{MOL CO}_2/\text{s}$ FOR PONDEROSA PINE PLANTS BEFORE AND AFTER EXPOSURE TO MIXED SMOKES AT: A) 2 mph; B) 4 mph; C) 6 mph; AND D) 10 mph

phytotoxic effects (Table 3.36). Overall, gas exchange results were consistent with visual plant symptoms, where toxicity ratings were 1 to 2 at 2-6 mph and 5 at 10 mph.

The foliar mass loading rates of the WP and HC components in the tall fescue plants at each of the wind speeds were much lower than those of the ponderosa pines (see Table 3.24). However, it should be remembered that the grass was exhibiting a much greater growth rate compared with the pines, and therefore, may have been more sensitive.

At wind speeds of 2 to 6 mph, net photosynthesis and dark respiration in tall fescue were reduced slightly with increasing wind speed, but were able to recover or exceed the initial rate over the 3-week post-exposure period (Figure 3.12 a, b, c, and d). Given the lack of visible phytotoxic effects on the foliage following exposure at 2 to 6 mph, (see Table 3.37, DR 1 to 3) this apparent recovery may be attributable in part to the new growth that the plant underwent. At 10 mph, the highest mass loading rate, there is a noticeable decline in both photosynthesis and respiration. This is consistent with the higher observed damage rating of 5 at this wind speed and no apparent recovery.

Responses to Cumulative Dose Exposures

Photosynthesis and respiration results for ponderosa pine and tall fescue from the CD test series are given in Figures 3.13a and b (MS-7-8), 3.14a and b (MS-9-10), and 3.15a and b (MS 13). Results are expressed as net $\mu\text{Mol CO}_2/\text{s}$ for each plant before and for 30 days after the first exposure. Included in the figures are the photosynthetic and dark respiration rates of control, non-exposed plants taken over the same time period as a determination of non-test related external/growth effects on the plants. The measurements given in the figures reflect the rates from a single plant. Given the need for repetitive sampling over time (several weeks) the determination of total leaf area, a destructive process for each individual measurement, was not possible, and absolute rates of photosynthesis and dark respiration were not obtained. Therefore, the data should be considered as indicative of metabolic trends, both to either corroborate visible phytotoxic symptoms, or indicate early deleterious disorders that had not been manifested visibly.

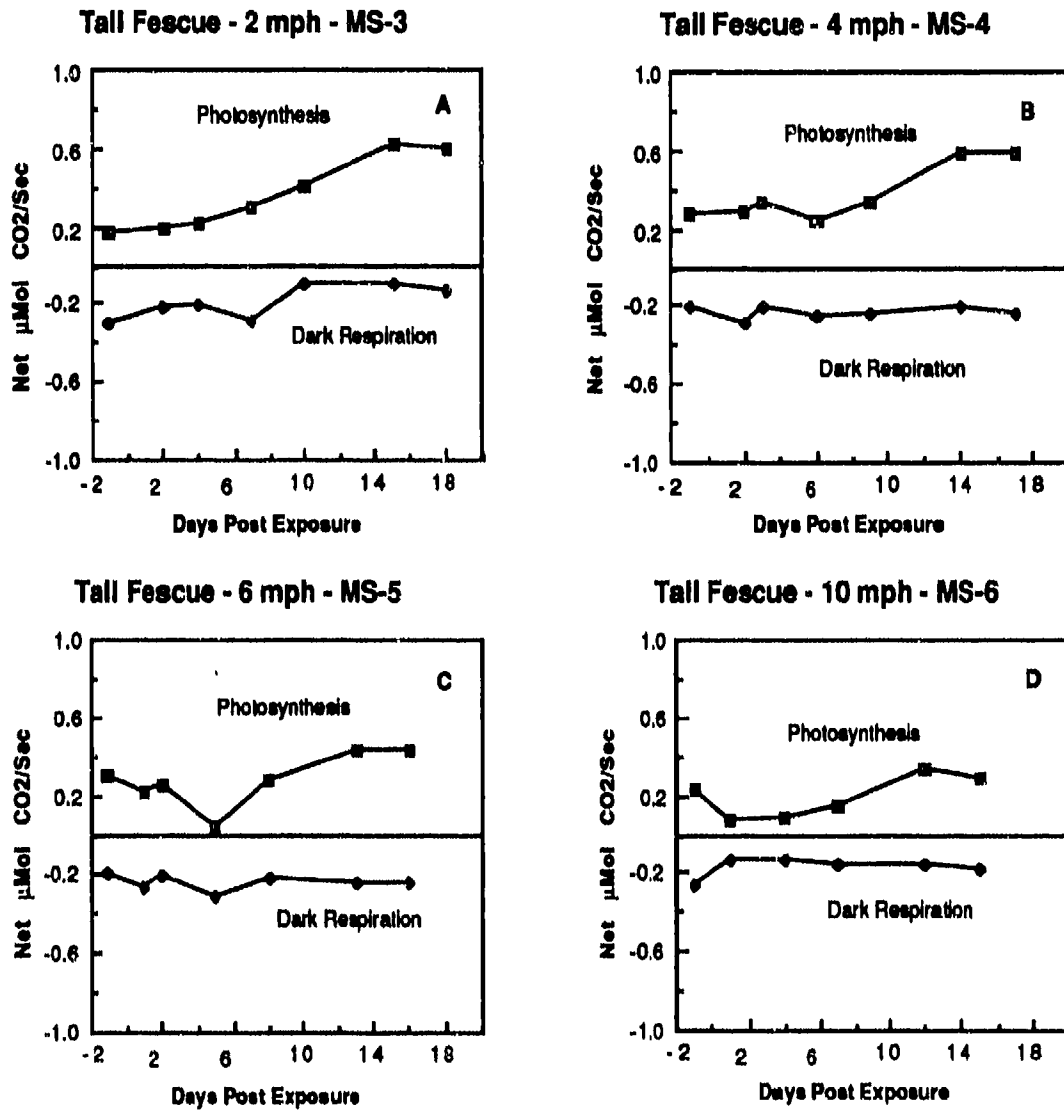
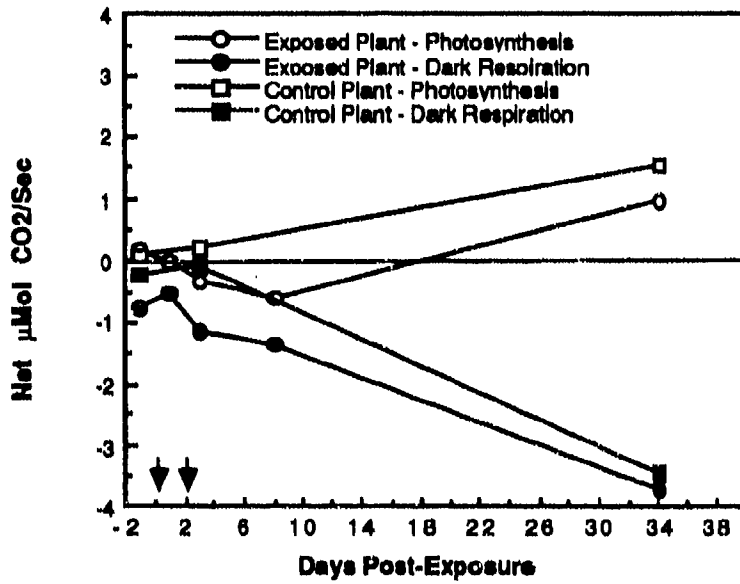

FIGURE 3.12. NET PHOTOSYNTHESIS AND DARK RESPIRATION IN $\mu\text{MOL CO}_2/\text{s}$ FOR TALL FESCUE PLANTS BEFORE AND AFTER EXPOSURE TO MIXED SMOKES AT: A) 2 mph; B) 4 mph; C) 6 mph; AND D) 10 mph

Ponderosa Pine - MS/CD 7-8



Tall Fescue - MS/CD 7-8

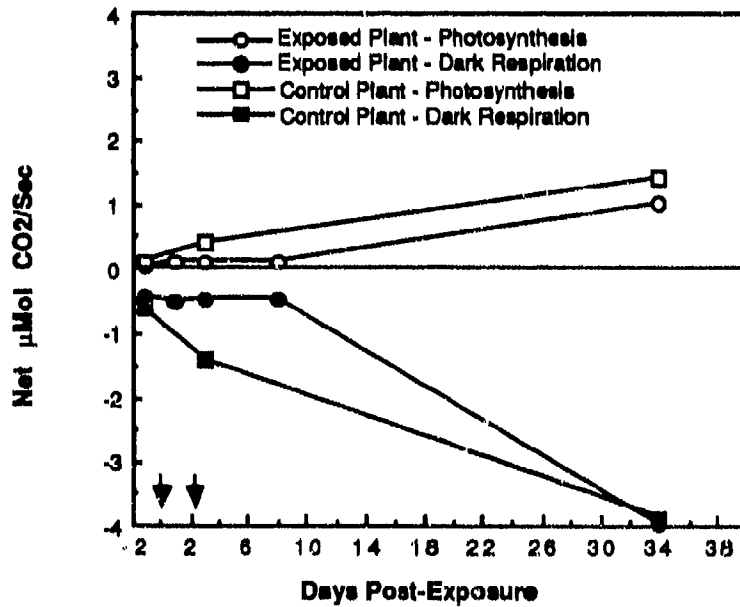

FIGURE 3.13. NET PHOTOSYNTHESIS AND DARK RESPIRATION IN $\mu\text{MOL CO}_2/\text{s}$ FOR EXPOSED: A) PONDEROSA PINE, B) TALL FESCUE, MS/CD PLANTS (MS-7-8), AND NON-EXPOSED CONTROL PLANTS BEFORE AND AFTER FIRST EXPOSURE DATE

In the MS-7-8 test series, plants were exposed principally to HC/WP (little or no FO). Toxicity based on the DR rating scale ranged from 1 to 3.5, or moderate damage, in pine and fescue. The gas exchange data provided in Figure 3.11 show both photosynthesis and respiration to be affected soon after exposure, followed by recovery in both pine and grass. The mixed-smoke test series employing HC/WP/FO (MS-9-10) resulted in minimal toxicity to pine (DR of 2) and moderate to severe damage to tall fescue (DR of 4.5). Gas exchange data for these plants (Figure 3.14) indicated a transient effect on photosynthesis following exposure, followed by recovery in fixation rates. Respiration was only transiently affected in the grass, but elevated for an extended period in the pine. The FO alone (MS-13, Figure 3.15) had no effect of photosynthesis, but substantially decreased respiration in the grass.

The WP/FO exposures resulted in toxicity values of 2.5 and 3 for ponderosa pine and tall fescue 30 days post-exposure. Photosynthesis in both plant species was reduced over most of the evaluation period (Figure 3.16). Respiration was also affected, but recovered to control levels after 30 days. In the HC/FO exposures (Figure 3.17), photosynthesis in both plant species was depressed following exposure, and subsequently recovered. Respiration increased in pine following exposure, and then attained control levels. In the grass, respiration increased with no sign of recovery to control levels.

It is clear from the gas exchange data that mixed smoke constituents can have an adverse, but transient, effect on metabolic processes such as photosynthesis and respiration. However, unlike many of the phenotypic symptoms, which are permanent (i.e., necrosis, leaf burn, leaf drop), gas exchange rates tend to describe the overall status of basic metabolic performance. Thus, this type of analysis permits rapid evaluation of both adverse trends and subsequent metabolic compensation or correction of damage from a whole plant basis. In the present studies, much of the recovery in gas exchange was a result of growth of new tissues, particularly in the grass. Yet it is clear that much of the phenotypic damage observed was transient in nature.

Ponderosa Pine - MS/CD 9-10

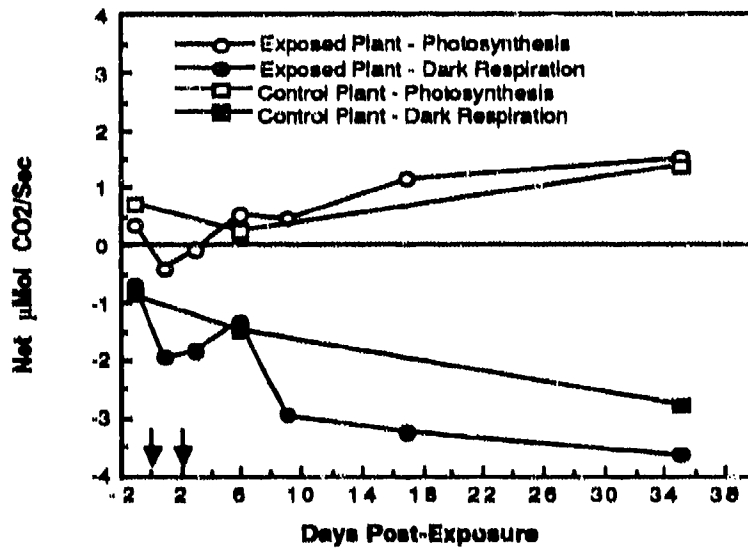

Tall Fescue - MS/CD 9-10

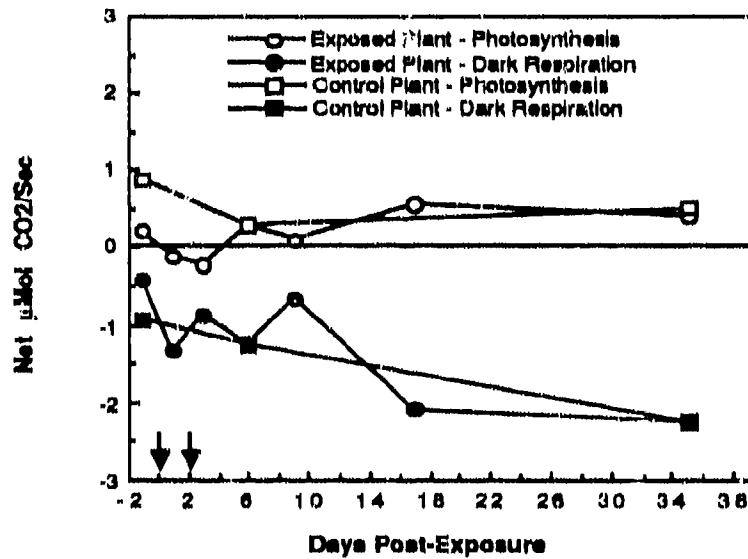

FIGURE 3.14. NET PHOTOSYNTHESIS AND DARK RESPIRATION IN $\mu\text{MOL CO}_2/\text{s}$ FOR EXPOSED: A) PONDEROSA PINE, AND B) TALL FESCUE, MS/CD PLANTS (MS-9-10) AND NON-EXPOSED CONTROL PLANTS BEFORE AND AFTER FIRST EXPOSURE DATE

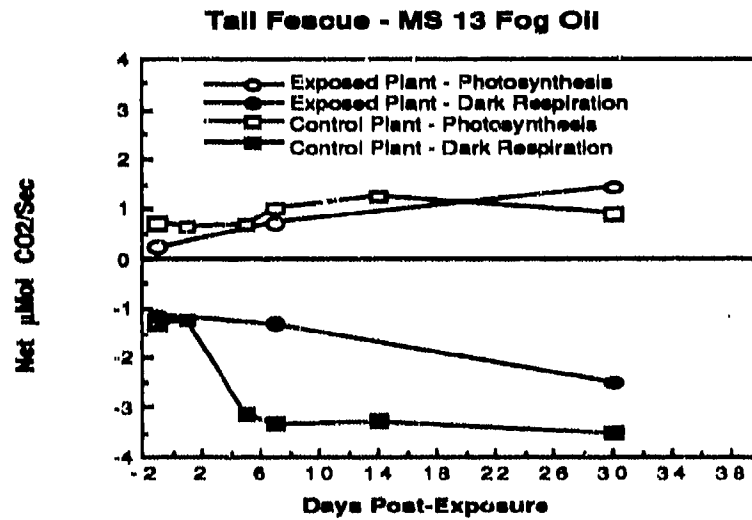
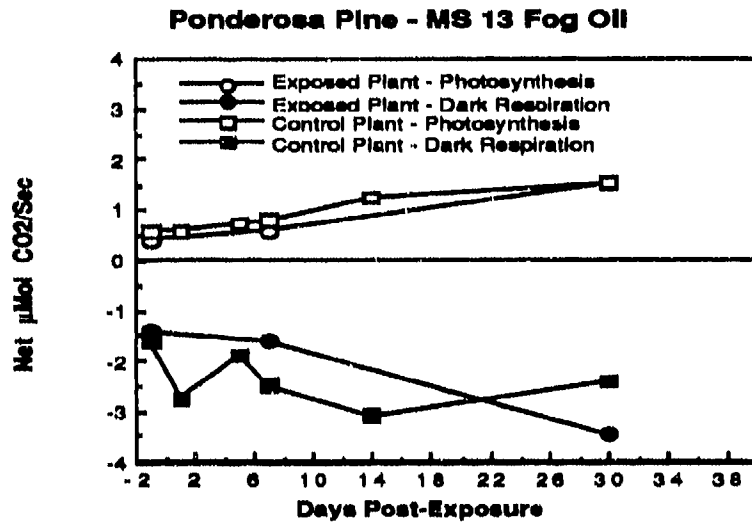
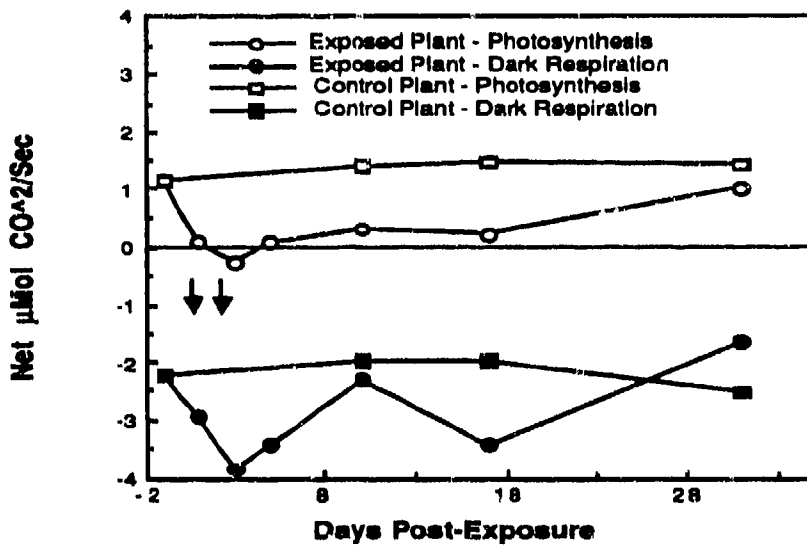

FIGURE 3.15. NET PHOTOSYNTHESIS AND DARK RESPIRATION IN $\mu\text{MOL CO}_2/\text{s}$ FOR EXPOSED: A) PONDEROSA PINE, AND B) TALL FESCUE, MS/CD SINGLE FO EXPOSURE (MS-13) PLANTS AND NON-EXPOSED CONTROL PLANTS BEFORE AND AFTER FIRST EXPOSURE DATE

Ponderosa Pine - MS 14-15



Tall Fescue - MS 14-15

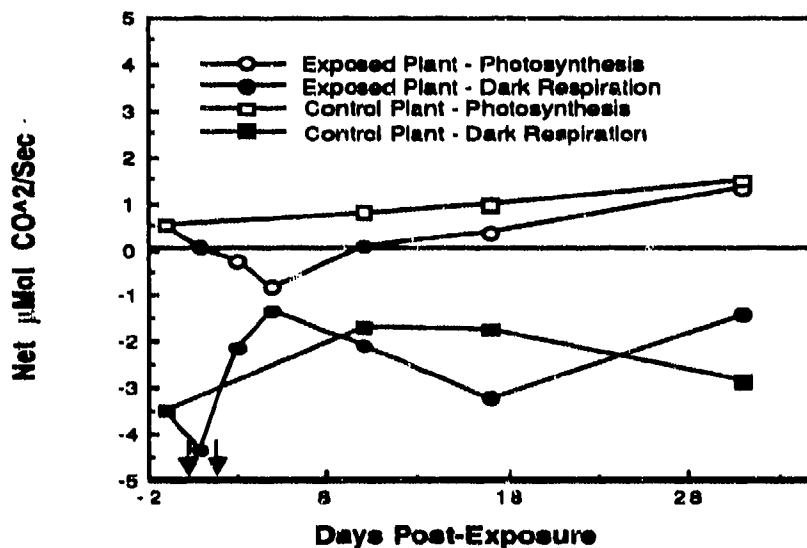

FIGURE 3.16. NET PHOTOSYNTHESIS AND DARK RESPIRATION IN $\mu\text{MOL CO}_2/\text{s}$ FOR EXPOSED: A) PONDEROSA PINE, AND B) TALL FESCUE, MS/CD WP/FO EXPOSURE (MS-14-15) PLANTS AND NON-EXPOSED CONTROL PLANTS BEFORE AND AFTER FIRST EXPOSURE DATE

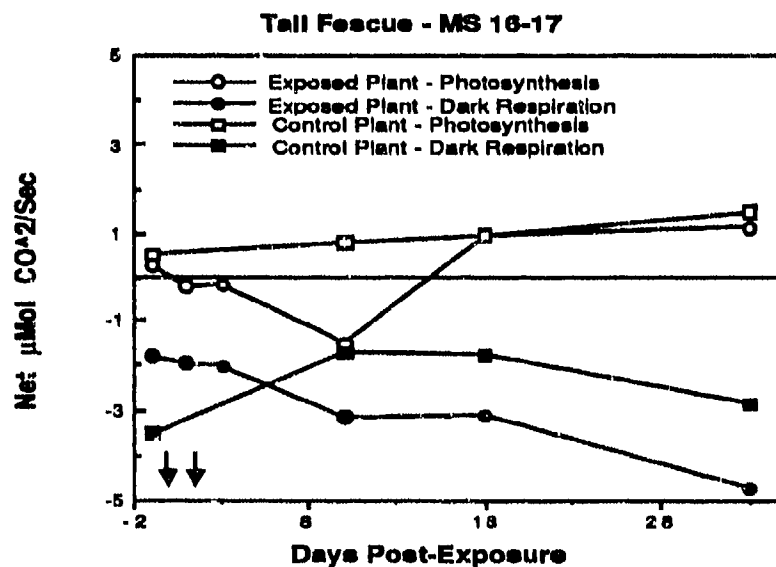
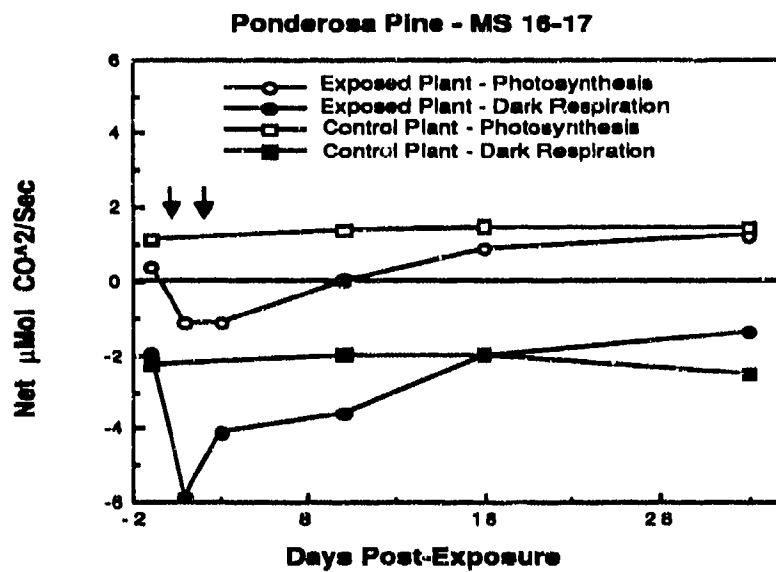

FIGURE 3.17. NET PHOTOSYNTHESIS AND DARK RESPIRATION IN $\mu\text{MOL CO}_2/\text{s}$ FOR EXPOSED A) PONDEROSA PINE, AND B) TALL FESCUE, MS/CD HC/FO EXPOSURE (MS-16-17) PLANTS AND NON-EXPOSED CONTROL PLANTS BEFORE AND AFTER FIRST EXPOSURE DATE

3.3.5 Contact Toxicity of Phosphorus Smoke Constituents

In the present studies, and in previous studies employing the acidic smokes RP/WP (Van Voris et al. 1987) and HC (Cataldo et al. 1989b), contact phytotoxicity appeared to be more prevalent with the phosphorus smokes. The pH of RP foliar leachates and impinger samples have been measured at 2 to 3, and results from the formation of phosphoric acid during combustion, while the pH of foliar HC leaches range from 4 to 5 and are likely a result of $ZnCl_2$ rather than HCl. Although it is possible that pH could account for the observed necrotic spotting and leaf burn, it does not explain the adverse residual effects observed in regrowth of grasses in earlier studies with RP/WP (Van Voris et al. 1987).

In the mixed-smoke tests, bush bean was also the most susceptible overall. In addition, overall contact toxicity in the mixed-smoke cumulative dose tests was substantially greater than previously experienced with the individual smokes, particularly when WP was one of the smokes (MS-7-10 and MS-14-15, see Tables 3.37, 3.38 and 3.40).

Although the foliar contact toxicity of phosphorus smokes was previously (Van Voris et al. 1987) attributed to either low pH or P-polymers, adverse effects in the present studies were observed at relatively low P mass loadings (30 to 60 $\mu\text{gP}/\text{cm}^2$) in the mixed smoke cumulative dose series. An attempt was made to resolve the apparent toxicity of the P smokes by applying a series of individual P smoke components to foliage; these were previously determined to be associated with P smokes (Van Voris et al. 1987). These components included phosphoric acid, polyphosphates with average chain lengths of P5 and P25, and polyphosphoric acid containing 35% P_2O_5 . Contact toxicity results are provided in Table 3.42. Foliar acidity (phosphoric acid, pH 1.1), at mass loading levels of 50 $\mu\text{g}/\text{cm}^2$, induced severe toxicity, but not at lower mass loading rates (6 $\mu\text{g}/\text{cm}^2$). The polyphosphates P5 and P25 produced no effects at levels expected to be present in deposited smokes (Van Voris et al. 1987). Polyphosphoric acid containing P_2O_5 and having a pH of 1.5 resulted in an observed toxicity at low mass loading levels (1.8 $\mu\text{g}/\text{cm}^2$), a level lower than required for a pH effect. These results, in conjunction with previous data indicating a residual toxicity for phosphorus smokes (Van Voris et al. 1987), would suggest that P_2O_5 , in addition to acidity, may provide the basis of the observed toxicity.

TABLE 3.42. EFFECTS OF DIRECT FOLIAR APPLICATION^(a) OF POLYPHOSPHATE SOLUTIONS OF VARYING CHAIN LENGTHS TO BUSH BEAN

Material (7 days Post-Exposure)	Form or Average Chain Length ^(b)	pH	Mass Loading	Damage Index ($\mu\text{g P/cm}^2$)
			(Average ML \pm s.d., n = 3)	(DR Scale)
Polyphosphoric Acid	P ₂ O ₅ (35%)	1.48	0.57 \pm 0.19	1.0
			1.85 \pm 0.54	2.0
Na Phosphate Glass	P ₅ \pm 2	8.30	1.87 \pm 0.48	0.0
Na Phosphate Glass	P ₂₅ \pm 4	7.48	3.92 \pm 0.77	0.0
Phosphoric Acid	H ₃ PO ₄	1.10	49.69 \pm 16.88	5.5
			6.30 \pm 2.22	1.0

(a) Applied as atomized solution to the leaves.

(b) Average number of P atoms on the chain.

3.3.6 Residual Effects of Mixed Smokes on Dry Matter Production of Follar-Exposed Tall Fescue

The residual effects studies are those that result from foliar absorption of smoke contaminants, transport to some distal site (i.e., root) and may exert an adverse effect in subsequent growth phases. Thus, a contaminant of this type could impact plant performance (plant biomass production) in perennials such as grasses and trees. In the present studies, residual effects were examined using tall fescue, which was foliarly contaminated with smokes. The presence of effects were based on dry matter production following two or more successive croppings or harvests of standing biomass.

Wind Speed /Range-Finding Test Series

Results for the WS/RF test series (MS-3-6) are provided in Table 3.43. First harvest and second harvest dry matter production rates for non-leached canopies were not significantly different from the controls at the $P > 0.01$ level. This would indicate that there is no significant

TABLE 3.43. EFFECTS OF MIXED-SMOKE RF/WS TESTS ON THE REGROWTH (DRY MATTER PRODUCTION) OF EXPOSED^(a) AND EXPOSED/LEACHED^(b) TALL FESCUE AT 30 AND 60 DAYS POST-EXPOSURE (MS-3-6)

Days Post- Exposure	Treatment	Dry Matter Production	
		Exposed	Exposed/Leached
(Avg. g dry wt. \pm s.d., n = 3) ^(c)			
30	Control	9.64 \pm 0.21	
	2 mph	7.81 \pm 0.73	7.58 \pm 0.54
	4 mph	8.33 \pm 0.28	7.69 \pm 0.54
	6 mph	8.64 \pm 0.46	8.57 \pm 0.09
	10 mph	7.53 \pm 0.80	7.55 \pm 0.07
60	Control	5.42 \pm 0.72	
	2 mph	5.11 \pm 0.56	4.84 \pm 0.40
	4 mph	5.18 \pm 0.36	5.19 \pm 0.16
	6 mph	5.56 \pm 0.29	5.59 \pm 0.27
	10 mph	4.82 \pm 0.30	4.80 \pm 0.72

(a) Rates of mass loading for the three components of the mixed smokes are given in Table 3.6.1.1.

(b) Leaching/simulated rainfall was conducted within 2 h of contamination and consisted of 350 mL of synthetic rainwater passed through the canopy over a 15-min period, and is equivalent to a 0.5-cm rainfall.

(c) No significant differences in dry matter production, $P > 0.01$.

residual effect of foliarly deposited mixed smoke (HC/WP/FO) based on the mass loading rates presented in Table 3.24. Dry matter production in plants subjected to a post-exposure leaching to remove surface deposits was similar for both controls and non-leached plants. This would indicate that application of simulated rainfall or post-exposure moisture events neither ameliorates nor intensifies the effects of these mixed smokes.

Symptomology taken on the plants before the first harvest indicated only slight differences between the treated plants and the controls with the treated plants showing occasional necrotic spotting and tip burn (1-2 cm). Following the first harvest, the plants appeared identical to the controls by the time of the second harvest.

Cumulative Dose Exposures and Special FO Test Series

The CD test series employed two sequential smoke exposures separated by a 48-h period. As noted, test series MS-7-8 can be considered a HC/WP-only test. Test series MS-9-10 employed HC/WP/FO. Test MS-13 consisted of only FO at the concentration projected for a single CDT exposure. Test MS-14-15 employed WP/FO, and test series MS-16-17 used HC/FO. Foliar mass loading rates for test series MS-14-17 were substantially greater overall than those from the WS/HF test series (Table 3.26) and the CD test series MS-7-10 (Table 3.27).

Table 3.44 provides results for residual toxicity of mixed-smoke contaminants from test series MS-7-10. Mass loading rates for WP were approximately 30 µgP/cm², and were 6 µg/Zn/cm² for HC. No significant differences (P>0.05) between control and treated plants were observed for either the standing biomass (30 days post-exposure) or the second harvest biomass (regrowth for 60 days post-harvest). The FO alone (MS-13) had no significant residual effects.

TABLE 3.44. EFFECTS OF CUMULATIVE MS EXPOSURE (MS-7-8; MS-9-10) AND SEPARATE FO EXPOSURE (MS-13) ON REGROWTH (DRY MATTER PRODUCTION) IN TALL FESCUE

Test/ Days After Last Exposure	Dry Matter Production (g dry wt) ^(a,b)	
	Control	Exposed Plants
MS-7,8 (HC/WP)		
30 days	15.43 ± 1.41	13.85 ± 1.36
60 days	2.45 ± 0.02	2.36 ± 0.05
MS-9,10 (HC/WP/FO)		
30 days	14.27 ± 1.02	13.21 ± 0.91
60 days	3.20 ± 0.24	2.91 ± 0.39
MS-13 (FO)		
30 days	14.27 ± 1.02	13.35 ± 0.43
60 days	3.20 ± 0.14	3.16 ± 0.24

(a) Average gram dry weight ± s.d.

(b) n = 3; no significant differences (P>0.05).

Mass loading rates for WP (MS-14-15) and HC (MS-16-17) constituents in the WP/FO and HC/FO ED exposure were similar to those attained in the three smoke exposures using HC/WP/FO (MS-7-10). The results tabulated in Table 3.45 indicate that there may be some degree of residual toxicity related to total biomass production in the first harvest from the WP/FO-treated fescue. However, dry matter production in the second harvest from treated plants is similar to controls. This indicates that any residual adverse effects are transient. In the CD test series employing HC/FO, no significant differences were noted in biomass production between treated and control plants.

TABLE 3.45. EFFECTS OF MIXED-SMOKE TESTS WITH PHOSPHOROUS (WP/FO, MS-14-15) OR ZINC (HC/FO, MS-16-17) WITH FOG OIL (FO) ON THE REGROWTH (DRY MATTER PRODUCTION) OF TALL FESCUE AT 30 AND 60 DAYS POST-EXPOSURE

Test Days Post-Exposure	Treatment	Dry Matter Production
(Avg. gram dry wt \pm s.d, n = 3)		
MS-14-15 (WP/FO)		
30	Control	22.51 \pm 2.22
	Exposed	17.70 \pm 2.35 ^(a)
60	Control	8.47 \pm 0.38
	Exposed	8.30 \pm 0.98
MS-16-17 (HC/FO)		
30	Control	22.81 \pm 1.84
	Exposed	20.69 \pm 1.48
60	Control	6.69 \pm 0.44
	Exposed	5.64 \pm 1.01

(a) No significant difference.

3.3.7 Indirect Soil Effects on Growth of Tall Fescue Grown on Soils Contaminated with Mixed Smokes from WS/RF Tests

In the indirect effects studies, soils were contaminated with smoke constituents and subsequently seeded with tall fescue. Any adverse, indirect effects would be noted by changes in establishment and biomass production of treated plants compared with controls. Pots of soil were exposed in the specified test series and then seeded with tall fescue. The

percent of germination for each of the pots was recorded, and the plants grown through two or more successive harvests for determination of relative plant biomass production.

Results from the WS/RF test series (MS-3-6) are shown in Table 3.46. Soil mass loading rates for these tests ranged from 5 to 10 $\mu\text{g Zn/cm}^2$, 6 to 34 $\mu\text{g P/cm}^2$, and 50 to 250 $\mu\text{g FO/cm}^2$ soil surface. These smoke events had no effect on seed germination in fescue. Germination percentages averaged 95-110% at all wind speeds for the Burbank soils and 90-110% for the Maxey Flats soils. Subsequent growth and dry matter production of the plants following three successive harvests indicated once again no apparent significant effects of the soil-deposited mixed smokes on the growth of plants.

TABLE 3.46. INDIRECT EFFECTS OF MIXED SMOKES ZINC (HC), PHOSPHOROUS (WP), AND FOG OIL (FO) DEPOSITED TO SOILS IN THE WS/RF TEST SERIES (MS-3-6) ON THE GROWTH OF TALL FESCUE

Soil Type	Wind Speed	Dry Matter Production (g dry wt)		
		1st Harvest (80 Days)	2nd Harvest (120 Days)	3rd Harvest (150 Days)
Average g dry wt \pm s.d.(a)				
Burbank	Control	4.48 \pm 0.29	15.21 \pm 1.48	4.41 \pm 0.46
	2 mph	3.65 \pm 0.56	15.80 \pm 2.33	5.09 \pm 0.24
	4 mph	4.83 \pm 0.08	14.62 \pm 4.03	4.25 \pm 0.66
	6 mph	3.97 \pm 0.06	14.04 \pm 1.15	4.43 \pm 0.31
	10 mph	4.83 \pm 0.50	17.24 \pm 2.57	4.17 \pm 0.73
Maxey Flats	Control	3.82 \pm 0.68	10.48 \pm 0.92	3.70 \pm 0.24
	2 mph	4.12 \pm 0.51	11.59 \pm 0.73	3.88 \pm 0.34
	4 mph	4.64 \pm 0.24	9.68 \pm 1.59	3.15 \pm 0.49
	6 mph	4.26 \pm 0.36	10.92 \pm 1.50	3.52 \pm 0.35
	10 mph	5.08 \pm 0.12	12.79 \pm 0.94	3.76 \pm 0.30

(a) No significant differences in dry matter production, $P \geq 0.1$.

In the CD test series, soil mass loading rates ranged from 4 to 23 $\mu\text{g P/cm}^2$ for WP and 2 to 20 $\mu\text{g Zn/cm}^2$ for HC. Results from these tests, collected over two growth periods, are given in Table 3.47. Again, no effects on seed germination were apparent. Also, no significant effects on biomass production were observed for any of the soils employed.

In the dual smoke CD tests employing WP/FO and HC/FO, soil mass loading rates were substantially higher. These ranged from 3 to 109 $\mu\text{g P/cm}^2$ in test series MS-14-15, and 3 to 26 $\mu\text{g Zn/cm}^2$ in test series MS-16-17. In test series MS-14-15 (Table 3.48), WP deposits had no effect on germination rates, and no adverse effect of first or second harvest biomass production in Burbank, Palouse, or Cinebar soils. There was a significant increase in first harvest biomass

TABLE 3.47. INDIRECT EFFECTS OF MIXED SMOKES DEPOSITED TO SOILS FOLLOWING CUMULATIVE DOSE (MS-7-8 AND MS-9-10) AND SPECIAL FO (MS-13) EXPOSURES ON THE GROWTH OF TALL FESCUE

Test	Soil Type/ Treatment	Dry Matter Production (g dry wt) ^(a,b)	
		1st Harvest (60 Days)	2nd Harvest ^(c) (60 Days)
MS-7-8	Burbank		
	Control	5.64 ± 0.85	14.92 ± 0.81
	Exposed	6.51 ± 0.24	15.25 ± 1.90
	Maxey Flats		
	Control	2.49 ± 0.68	11.72 ± 3.00
	Exposed	3.14 ± 0.27	9.11 ± 0.69
MS-9-10	Palouse		
	Control	5.53 ± 0.24	17.76 ± 0.95
	Exposed	7.11 ± 0.52	18.82 ± 1.77
	Burbank		
MS 13	Control	3.92 ± 0.45	8.14 ± 4.47
	Exposed	3.69 ± 0.34	8.04 ± 3.46
	Palouse		
	Control	5.50 ± 0.45	12.15 ± 0.94
	Exposed	5.54 ± 1.51	13.44 ± 0.78
MS 13	Burbank		
	Control	5.24 ± 0.53	11.04 ± 2.29
	Exposed	6.18 ± 0.61	10.52 ± 1.06
	Palouse		
	Control	7.57 ± 0.38	12.39 ± 0.80
	Exposed	7.67 ± 0.83	12.69 ± 0.54

(a) Average g dry weight ± s.d.

(b) n=3; no significant effect at P<0.1.

(c) Experiment terminated at second harvest.

TABLE 3.48. INDIRECT EFFECTS OF MIXED SMOKES PHOSPHOROUS (WP, MS-14-15) AND FOG OIL DEPOSITED TO SOILS IN THE MS-CD TEST SERIES ON GROWTH OF TALL FESCUE

Test	Soil Type/ Treatment	Dry Matter Production (g dry wt)		
		1st Harvest (60 Days)	2nd Harvest (120 Days)	
Average g dry wt \pm s.d., n = 3				
MS-14-15	Burbank	Control	7.96 \pm 0.55	12.73 \pm 1.15
		Exposed	8.25 \pm 0.83	15.68 \pm 1.90
	Maxey Flats	Control	4.80 \pm 0.56	12.90 \pm 1.21
		Exposed	3.39 \pm 0.24*	9.40 \pm 1.74(a)
	Palouse	Control	5.88 \pm 0.19	12.06 \pm 2.46
		Exposed	9.27 \pm 2.01*	14.58 \pm 1.73
	Cinebar	Control	8.23 \pm 1.98	12.87 \pm 2.14
		Exposed	9.70 \pm 1.31	14.88 \pm 2.14

(a) Significant at $P \leq 0.1$.

production for Palouse soils ($P \leq 0.1$); this may result from the nutrient value of the phosphorus. Some inhibition in biomass production was observed for both the first and second harvests of grass from Maxey Flats soil.

Soil mass loading for the HC/FO CD test series ranged from 3 to 26 $\mu\text{g Zn/cm}^2$ soil. No effects were noted on germination. Biomass results from the HC/FO test series are provided in Table 3.49. Dry matter production, based on controls, was unaffected by HC/FO deposition ($P > 0.05$).

In general, for the three mixed smoke scenarios no adverse indirect effects were noted for either germination of tall fescue seed or in biomass production through two to three harvests. Only in the case of WP/FO exposures was there any indication of reduced biomass, and this may result from the low fertility of Maxey Flats soil.

TABLE 3.49. INDIRECT EFFECTS OF MIXED SMOKES ZINC (HC) (MS-16-17) AND FOG OIL (FO) DEPOSITED TO THE SOILS IN THE MS-CD TEST ON GROWTH OF TALL FESCUE

Test	Soil Type/ Treatment	Dry Matter Production (g dry wt)	
		1st Harvest (60 Days)	2nd Harvest (120 Days)
Average dry wt \pm s.d., n = 3			
MS-16-17	Burbank		
	Control	7.30 \pm 1.55	13.96 \pm 2.16
	Exposed	6.74 \pm 1.61	14.66 \pm 3.68
	Maxey Flats		
	Control	4.59 \pm 1.05	13.03 \pm 1.01
	Exposed	4.50 \pm 1.57	12.33 \pm 2.32
	Palouse		
	Control	6.84 \pm 0.79	17.15 \pm 2.01
	Exposed	7.09 \pm 0.36	17.04 \pm 2.48
	Cinebar		
	Control	6.78 \pm 0.62	10.34 \pm 1.78
	Exposed	7.27 \pm 1.26	11.05 \pm 1.65

3.4 EARTHWORM BIOASSAY MIXED-SMOKE EFFECTS

Earthworms were exposed to mixed smokes in each of the range-finding/wind speed (WS/RF) test series and the cumulative dose test series. Earthworms were maintained and exposed in a synthetic soil mixture to provide consistency. In each of these treatments, three replicates of five worms/replicate were employed to evaluate mature worm mortality. The evaluations were made following a 2-week incubation period post-exposure to ensure maximum worm contact with the material deposited upon the soil surface.

The soil mass loading and response results of MS-3-6 are shown in Table 3.50. In each test there was a survival rate of 100% with no apparent effects on the activity, or motility of worms based on contact pressure, of the worms. The concentrations reported for each of the smokes components, Zn, FO, and P in the table were those in the artificial soil at the end of the 2-week incubation period. Soil mass loadings for HC-Zn ranged from 0.6 to 9 $\mu\text{g}/\text{cm}^2$

soil surface, from 38 to 143 $\mu\text{g P/cm}^2$ for WP, and from 292 to 525 $\mu\text{g/cm}^2$ for FO soil. The FO levels were likely reduced by evaporation of the 2 week study period (Cataldo et al. 1989). Neither Zn nor P would have undergone significant depuration over the 2 weeks.

TABLE 3.50. INFLUENCE OF SOIL-DEPOSITED PHOSPHOROUS (P), Zn (HC), AND FOG OIL (FO) FROM MIXED-SMOKE RF/WS TESTS ON THE SURVIVAL OF EARTHWORMS (*Eisenia foetida*). ARTIFICIAL SOILS (70 g) AND WORMS EXPOSED TO SMOKE AND HELD FOR 14 DAYS POST-EXPOSURE

Test	Condition	Soil Mass Loading			Earthworm	
		Zn ^(a)	Fog Oil ^(a)	P ^(a)	Survival	Condition
		($\mu\text{g/cm}^2$)				
MS-3	2 mph	0.97	416.02	38.32	5/5	Healthy
		0.85	525.06	47.16	5/5	Healthy
		0.65	409.27	40.08	5/5	Healthy
MS-4	4 mph	1.30	390.16	56.59	5/5	Healthy
		3.33	338.44	91.96	5/5	Healthy
		2.39	316.59	79.58	5/5	Healthy
MS-5	6 mph	3.36	331.79	91.37	5/5	Healthy
		2.77	305.93	80.17	5/5	Healthy
		1.62	290.73	78.99	5/5	Healthy
MS-6	10 mph	8.78	424.25	101.98	5/5	Healthy
		8.96	515.35	143.83	5/5	Healthy
		7.25	292.95	91.94	5/5	Healthy

(a) Soil samples taken after the 2-week incubation period.

Results of the earthworm assays performed during the mixed-smoke cumulative dose test series, and during the single special fog oil exposure, are provided in Table 3.51. For test series MS-7-10, mass loading for WP, HC, and fog oil constituents were approximately 230 $\mu\text{g P/cm}^2$, 4 $\mu\text{g Zn/cm}^2$, and 30 $\mu\text{g FO/cm}^2$, respectively. Thirty worms were exposed during each of the tests and none exhibited apparent deleterious effects during and up to 14 days post-exposure. These results, based on mass loading rates, are consistent with those reported for the previous WS/RF test series.

Table 3.52 provides a similar data set for WP/FO (MS-14-15) and HC/FO (MS-16-17) cumulative dose exposures, rather than the three smoke scenario. Mass loading rates were comparable to MS-7-10. Again, no effects were noted with respect to earthworm survival.

TABLE 3.51. INFLUENCE OF SOIL-DEPOSITED PHOSPHOROUS (WP), ZINC (HC), AND FOG OIL (FO) FROM MIXED-SMOKE CUMULATIVE DOSE (MS/CD) TESTS ON THE SURVIVAL OF EARTHWORMS (*Eisenia foetida*). EXPERIMENT MS-13 COMPRISED A SINGLE FO EXPOSURE TO SIMULATE THE PREVIOUS MIXED-SMOKE EXPOSURES (MS 7-10). ARTIFICIAL SOILS (70 g) AND WORMS EXPOSED TO SMOKE AND HELD FOR 14 DAYS POST-EXPOSURE; DATA ARE AVERAGES OF THREE POTS \pm S.D.

Test	Phosphorous (WP)	Zinc (HC)	Fog Oil (FO)	Survival	Condition
$\mu\text{g}/\text{cm}^2 \pm \text{s.d. (n = 3)}$					
MS-7-8	244.05 \pm 70.18	4.50 \pm 2.08	-	30/30	Healthy
MS-9-10	220.36 \pm 22.34	3.40 \pm 0.58	-	30/30	Healthy
MS-1	-	-	30.11 \pm 13.14	30/30	Healthy

TABLE 3.52. INFLUENCE OF SOIL-DEPOSITED PHOSPHOROUS (WP) AND ZINC (HC) FROM MIXED-SMOKE CUMULATIVE DOSE (MS/CD) TESTS ON THE SURVIVAL OF EARTHWORMS (*Eisenia foetida*). ARTIFICIAL SOILS (70 g) AND WORMS EXPOSED TO SMOKE AND HELD FOR 14 DAYS POST-EXPOSURE; DATA ARE AVERAGES OF THREE POTS \pm S.D.

Test	Phosphorous (WP)	Zinc (HC)	Survival	Condition
$\mu\text{g}/\text{cm}^2 \pm \text{s.d. (n = 3)}$				
MS-14-15	278.76 \pm 177.65	-	30/30	Healthy
MS-16-17	-	9.41 \pm 1.43	30/30	Healthy

In previous earthworm studies with FO and HC alone (Cataldo et al. 1989a; 1989b), no significant toxicity to the worms was observed; these results are supported by the present data. However, significant toxicity to P smokes was observed in previous tests (Van Voris et al. 1987). The soil concentrations in the latter studies were higher than obtained in the present studies and probably account for the differing results. It can be assumed that combinations of two or three smokes did not have any additive effect with respect to earthworm toxicity, at least at these mass loading rates.

3.5 SOIL MICROBIAL EFFECTS

The effects of mixed-smoke obscurant exposure on soil microbial populations and soil microbially mediated processes were evaluated with two different soil types. The soil microbial population plays a key role in nutrient cycling and the biodegradation of organic compounds in soil. The decomposition of organic material in soil into mineral forms and the cycling of plant nutrients is mediated by the soil microbial processes. The decomposition of organic matter by the soil microbial population is critical to the cycling of important nutritional elements (nitrogen, phosphorus, sulfur, and some trace metals). Soil microbial decomposition processes also detoxify xenobiotic chemicals that may be released to the environment. Therefore, any physical or chemical perturbation on the soil system that disrupts these microbially mediated processes can indirectly influence plant growth and directly affect the soil's ability to decompose organic matter and detoxify xenobiotics.

Soil enzyme activity and respiration of soil are indicative of the activity of the cumulative heterotrophic microbial population. Soil respiration is one of the most frequently used indices of microbial activity in soil (Anderson 1982). Soil dehydrogenase activity has been used in the past to measure the activity of the soil microbial population and is an index of endogenous soil microbial activity (Moore and Russell 1972). Dehydrogenase enzymes are intracellular and involved in microbial respiratory processes necessary for the breakdown of organic compounds in soil.

Phosphatases, which can exist extracellularly, are a broad group of enzymes that cleave both esters and anhydrides of phosphates from complex organophosphorus compounds. Their activities in the soil are important for the mineralization of phosphorus from soil organic matter to the chemical forms available to plants (Ramirez-Martinez 1968). The enzymes are classified as acid and alkaline phosphatase because they show their optimal activities in acid and alkaline ranges, respectively. Because the pH of soils used for this study ranged from 5.6 to 7.4, a modified method by Klein et. al (1979), which measured phosphatase activity at pH 8.6, was chosen as an assay to study the effect of mixed smoke on phosphorus cycling in soil.

Nitrogen is the nutrient most limiting in agricultural (Stevenson 1982) and arid land ecosystems (West and Skujins 1978). Nitrogen is considered a macronutrient because plants require large quantities of this element for growth. Nitrogen is also an essential element for the soil microbial population. The conversion of organic nitrogen to available inorganic forms combines two distinct microbiological processes: ammonification, which converts organic nitrogen to ammonia, and nitrification, which transforms ammonia to nitrate. Nitrification in soil is mediated by nitrifying bacteria, or nitrifiers. The *Nitrosomonas* sp. are responsible for the conversion of ammonia to nitrite and the *Nitrobacter* sp. are responsible for the further oxidization of nitrite to nitrate, a soluble and mobile form in soil used by plants and other microorganisms.

Soil organisms are also sources of food for the soil fauna (e.g., mites, arthropods, worms) and thus occupy an important position low in the food chain. A deleterious impact on the various soil microbial populations can affect soil invertebrate life and the soil-dwelling animals that depend on their populations for food. Effects of mixed smokes obscurant on the soil microbial community, therefore, were evaluated with these four principal soil microbiological parameters, namely, soil respiration, soil dehydrogenase activity, soil phosphatase activity, and soil nitrifying bacteria populations.

3.5.1 Soil Respiration

Soil respiration is indicative of the activity of the cumulative heterotrophic microbial population. It can be measured by CO₂ evolution or O₂ consumption, or both. Heterotrophic activity is responsible for the decomposition of natural and xenobiotic carbon compounds in soils and for the cycling and mineralization of essential inorganic nutrients such as nitrogen, phosphorous, and sulfur.

Respiration of Palouse soil was slightly inhibited by the mixed-smoke exposure at 4.57 m/s (10 mph, test MS-6) as shown in Figure 3.18. An unexposed control soil amended with 150 mg glucose was included to ensure that a viable heterotrophic population was present as evidenced by the substantial increase in oxygen consumption. In the cumulative dose tests (Figure 3.19), only two cases of significant difference in respiration were observed between the exposed and unexposed soils. Palouse soil exposed to a cumulative dose of FOWP and Burbank soil exposed to a cumulative dose of HC/FO were significantly different from the controls when measured immediately after exposure. However, the impact was slight as evidenced by the recovery of these soils after a 4-week incubation. This indicates that these mixed-smoke exposures probably were not very toxic to soil heterotrophic microbial activity, and their effects are most likely transient in nature.

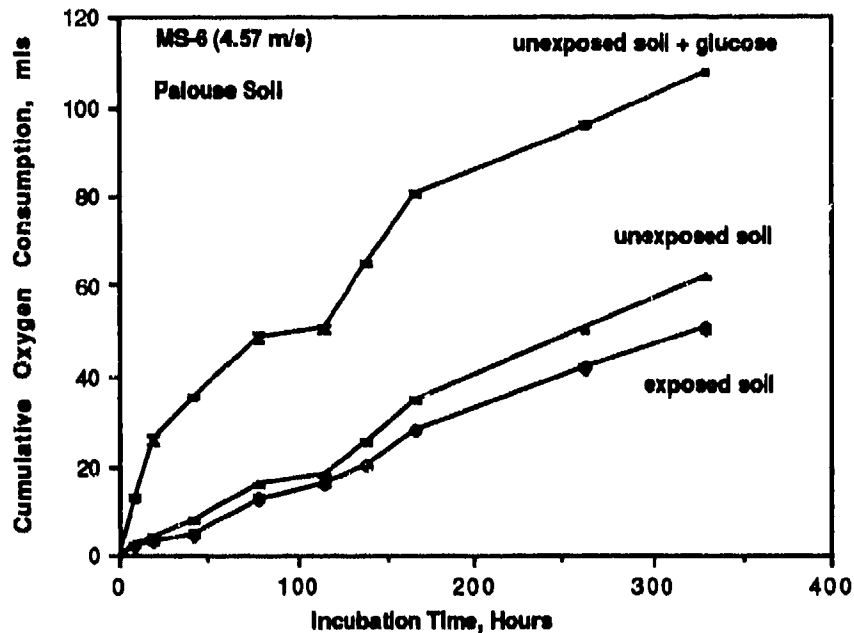

FIGURE 3.18. EFFECT OF MIXED-SMOKE EXPOSURE AT A WIND SPEED OF 4.57 m/s (TEST MS-6) ON PALOUSE SOIL RESPIRATION. ERROR BARS REPRESENT STANDARD DEVIATIONS, $n = 2$

The FO smoke, in either single or cumulative dose, stimulated the soil respiration activity to about 110% (Cataldo et al. 1989a). This activity was inhibited by a single or cumulative dose of HC smoke to 50% (Cataldo et al. 1989b). Cumulative doses of mixed smokes caused no effects on soil respiration with the exception of HC/FO mixed smokes, which caused the activity to decline to 70%. It is possible that FO might have a positive synergistic effect. Because data were not available for the effect of phosphorus smoke alone, conclusions of synergism among the phosphorus, FO, and HC smokes could not be made.

3.5.2 Soil Dehydrogenase Activity

The inhibition of enzymes that drive key metabolic reactions in microbial cells is one main cause of chemical toxicity to microorganisms and soils. Microbial dehydrogenase enzyme systems catalyze the oxidation of organic material and fulfill an important role in the soil carbon cycle. The assay of soil dehydrogenase activity is a general indicator of the potential activity of the soil microbial population and has been recommended as an index of general soil microbial activity (Casida 1967; Skujins 1967).

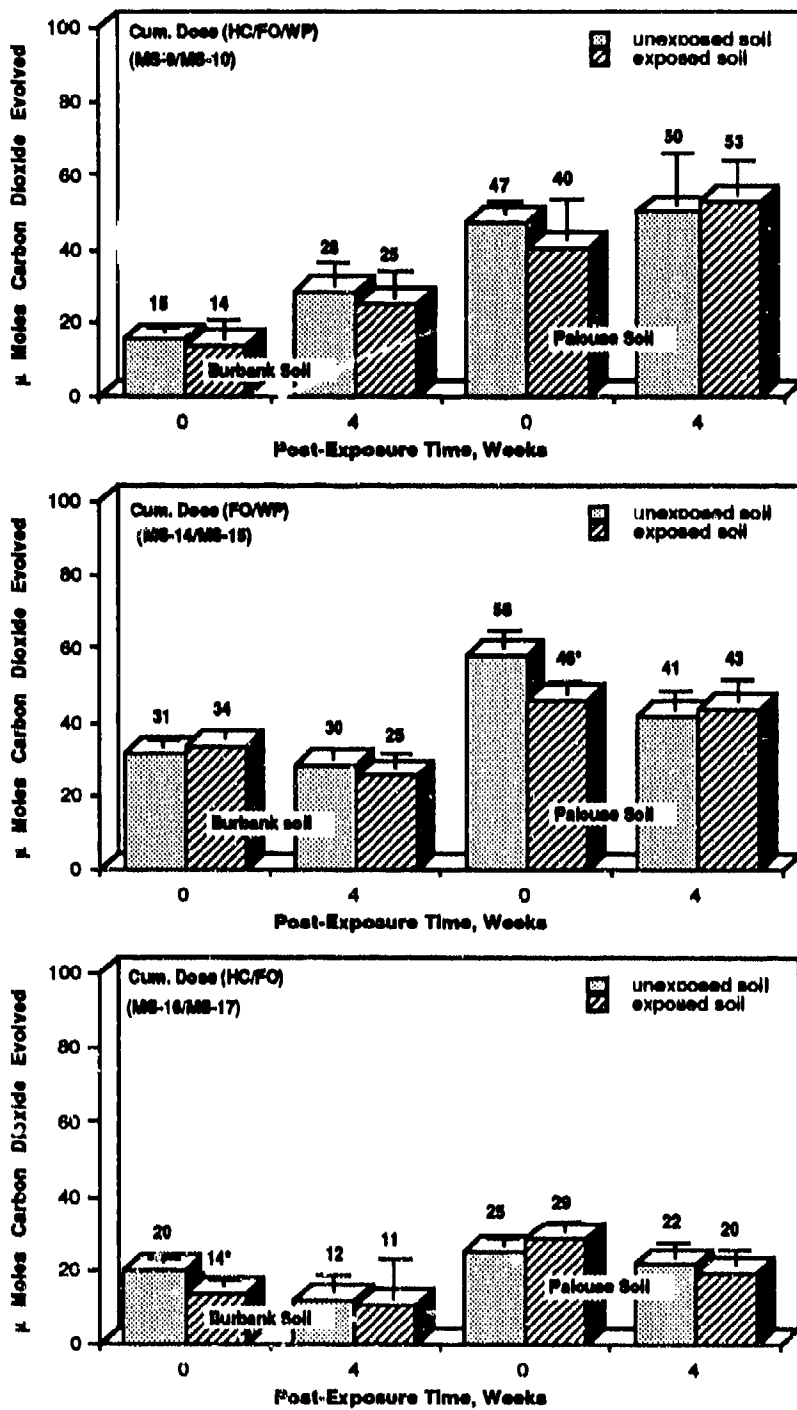

FIGURE 3.19. EFFECT OF CUMULATIVE DOSE OF MIXED-SMOKE ON SOIL RESPIRATION. ERROR BARS REPRESENT STANDARD DEVIATIONS, N = 3. *DENOTES SIGNIFICANT DIFFERENCE FROM CONTROLS (UNEXPOSED SOILS) BASED ON T-TEST ($P \leq 0.1$)

Except for the 2.73 m/s (Test MS-5) wind speed test, dehydrogenase activity in Burbank soil decreased to 70-90% of control level immediately after smoke exposure in the range-finding/wind speed exposure test series (Table 3.53). Dehydrogenase activity further decreased to about 50% of the control after 4 weeks. With the 2.73 m/s test, the activity was inhibited at 50% of the control immediately after exposure and remained depressed at this level for 4 weeks. Also, in the 2.73 m/s test, the initial effect on dehydrogenase activity in Palouse soil was severe at 33% of control level, although it recovered to 68% of the control after 4 weeks. In the Palouse soil, a general recovery trend was observed, except for in the 0.92 m/s (Test MS-3) wind speed test, which had decreased activity with increasing incubation time. In the range-finding/wind speed test series, the 2.73 m/s test seemed to cause more enzyme inhibition on both Burbank and Palouse soils than did the 0.92, 1.83, and 4.57 m/s tests. One explanation may be the unusually low FO soil mass loading. Soil mass loading for Burbank and Maxey Flats soils following exposure to mixed smokes RF/WS tests was unusually low in fog oil (48.34 and 44.57 $\mu\text{g}/\text{cm}^2$, respectively) when compared with other RF/WS tests, which ranged from 108 to 267 $\mu\text{g}/\text{cm}^2$. Although direct data for soil mass loading on Palouse soil are not available, judging from the low FO deposition on Burbank and Maxey Flats soils, it is conceivable that the FO deposition on Palouse soil was also low. Previous studies on FO exposure (Cataldo et al. 1989a) have indicated that FO has a stimulatory and possibly protective effect on soil enzyme activities. Thus, the low enzyme activities observed in mixed-smoke exposure in the RF/WS tests may be attributed to the low FO concentration in the mixed smoke.

Figure 3.20 illustrates the effects of cumulative dose exposures of mixed smokes of HC/FO/WP (MS-9/MS-10), FO/WP (MS-14/MS-15), and HC/FO (MS-16/MS-17) on soil dehydrogenase activity. Inhibition was higher than shown in Table 3.53 for the single dose exposure in the range-finding/wind speed test series. The relative order of toxicity for the mixed smokes toward soil dehydrogenase was HC/FO/WP > FO/WP > HC/FO. In general, a cumulative dose of mixed smoke exerted less toxic impact on Palouse soil dehydrogenase activity than on Burbank soil. Although the activity seemed to increase with increased post-exposure time, it remained inhibited, 11-32% of the control in the Burbank soil and 54-59% of the control in the Palouse soil after 4 weeks. The only exception was the Palouse soil in the HC/FO exposure, which recovered to the level of unexposed control after 4 weeks.

Previous studies with individual smoke exposures have shown that phosphorus smokes decreased dehydrogenase activity in Burbank soil to 0-6%, with no sign of recovery 4 weeks later (Van Voris et al. 1987). Single doses of HC smoke exposures caused moderate inhibition. Recovery to unexposed control levels occurred in Palouse soil, but not in Burbank soil (Cataldo et al. 1989b); cumulative doses of HC had severe impact (1-8% of control level) on both soils (Cataldo et al. 1989b), whereas FO smoke stimulated dehydrogenase activity up to 300% in either single or cumulative dose exposures (Cataldo

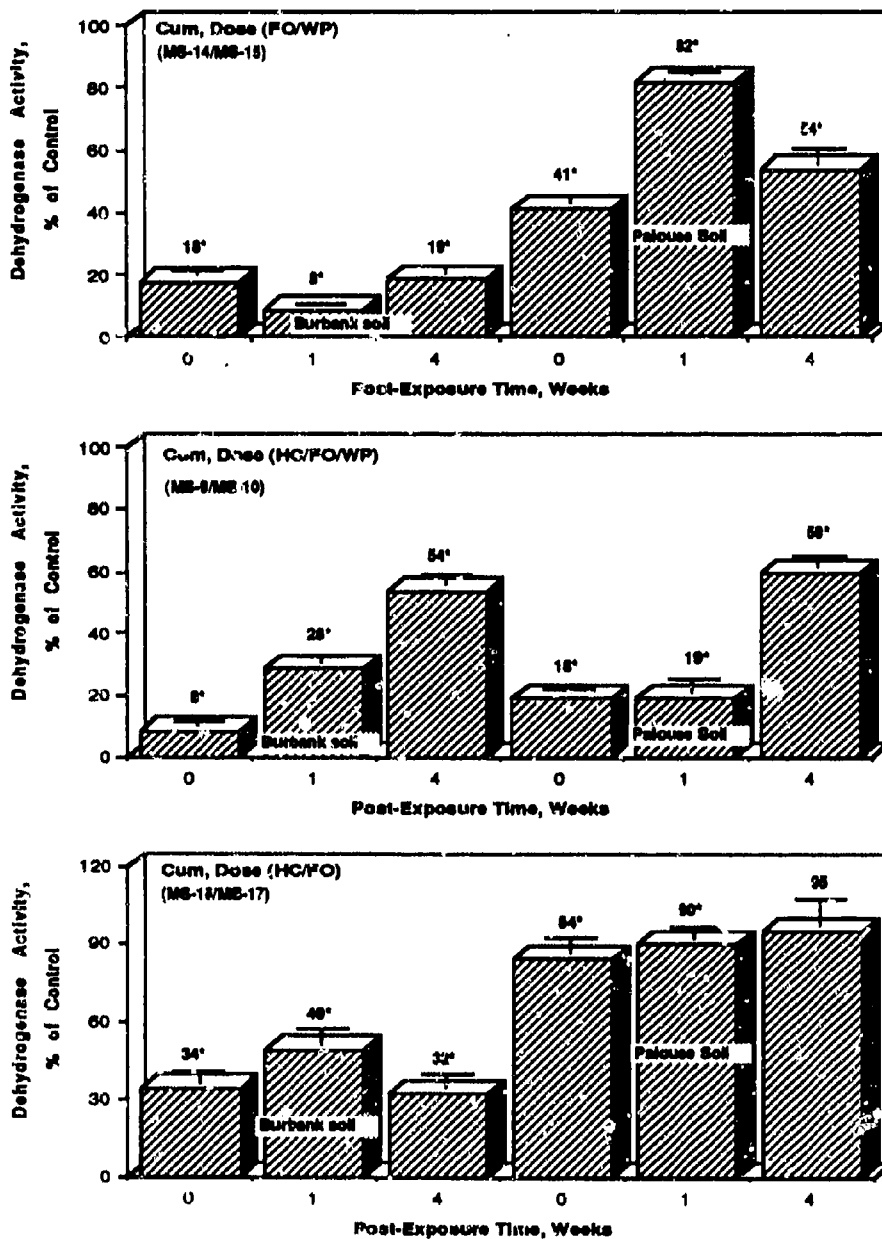

FIGURE 3.20. DEHYDROGENASE ACTIVITY (EXPRESSED AS % OF THE CONTROL) IN SOIL EXPOSED TO A CUMULATIVE DOSE OF MIXED SMOKES. ERROR BARS REPRESENT STANDARD DEVIATIONS, $n = 3$. *DENOTES SIGNIFICANT DIFFERENCE FROM CONTROLS (UNEXPOSED SOILS) BASED ON T-TEST ($P \leq 0.05$)

et al. 1989a). In general, single or cumulative dose of mixed-smoke exposure inhibited neither the severe inhibitory effect of phosphorus smoke nor the profound stimulatory effect of FO, suggesting a synergistic effects among the phosphorus, HC, and FO smokes.

Soil Phosphatase Activity

Phosphatases, which can exist extracellularly, are a broad group of enzymes that cleave esters and anhydrides of phosphates from complex organophosphates and are important in the mineralization of phosphorus from soil organic matter (Ramirez-Martinez 1968).

TABLE 3.53. DEHYDROGENASE ACTIVITY IN SOIL EXPOSED TO MIXED SMOKES IN THE RANGE-FINDING / WIND SPEED TEST SERIES

		Dehydrogenase Activity (% of Control)(a)							
		Burbank Soil				Palouse Soil			
Post Exposure Time (Weeks)	Test No.-> WS(b)	MS-3 (0.92m/s)	MS-4 (1.83m/s)	MS-5 (2.73m/s)	MS-6 (4.57m/s)	MS-3 (0.92m/s)	MS-4 (1.83m/s)	MS-5 (2.73m/s)	MS-6 (4.57m/s)
0		90(6) ^(c)	70(9) [*]	47(7) [*]	89(4) [*]	85(7) [*]	80(6) [*]	33(5) [*]	62(6) [*]
1		82(7) [*]	61(4) [*]	53(8) [*]	78(7) [*]	44(3) [*]	69(7) [*]	40(8) [*]	48(7) [*]
4		53(5) [*]	52(5) [*]	47(6) [*]	54(4) [*]	54(3) [*]	81(10) [*]	68(9) [*]	82(8) [*]

(a) Mean(standard deviation), n=3.

(b) WS = wind speed in meter per second.

(c) ^{*}Denotes significant difference from controls (unexposed soils) based on the Student t-test, (P ≤ 0.05).

The effect of mixed-smoke exposure of the RFWS tests on soil phosphatase activity is presented in Table 3.54. Although both Burbank and Palouse soils exposed to 0.92 or 1.83 m/s tests (MS-3, MS-4) resulted in an immediate decrease in phosphatase activity, the activity was able to recover to the level of control after 4 weeks. On the 2.73 and 4.57 m/s tests (MS-5, MS-6), the time zero inhibition was less severe than the other two tests. However, the Burbank soil phosphatase activity declined to 48% of the control 4 weeks after exposure to 4.57 m/s (MS-6) mixed smoke. The higher than normal inhibitory effect on soil dehydrogenase activity by the 2.73 m/s exposure was not found with the soil phosphatase activity.

TABLE 3.54. PHOSPHATASE ACTIVITY IN SOIL EXPOSED TO MIXED SMOKES (RANGE-FINDING / WIND SPEED TEST SERIES)

		Phosphatase Activity (% of Control)(a)							
		Burbank Soil				Palouse Soil			
Post Exposure Time (Weeks)	Test No.-> WS(b)	MS-3 (0.92m/s)	MS-4 (1.83m/s)	MS-5 (2.73m/s)	MS-6 (4.57m/s)	MS-3 (0.92m/s)	MS-4 (1.83m/s)	MS-5 (2.73m/s)	MS-6 (4.57m/s)
0		88(2)* ^(c)	43(10)*	74(8)*	79(6)*	51(2)*	26(3)*	69(6)*	74(6)*
1		110(4)*	112(9)	76(9)*	93(10)*	72(10)*	92(9)	89(7)*	70(7)*
4		101(6)	111(12)	72(5)*	48(4)*	93(7)	83(9)*	84(13)	92(2)*

(a) Mean (standard deviation), n=3.

(b) WS = wind speed in meter per second.

(c) *Denotes significant difference from controls (unexposed soils) based on the Student t-test, (P ≤ 0.05).

Burbank soil exposed to the cumulative dose of mixed smokes exhibited a more pronounced effect on soil phosphatase activity than Palouse soil, as shown in Figure 3.21. This effect on Burbank soil was also more persistent as is evident by the continued decline in phosphatase activity after 4 weeks. Compared with the Burbank soil, effects on Palouse soil phosphatase activity by the cumulative dose of mixed smokes were moderate and not as persistent. This was especially true in the HC/FO test (MS-16/MS-17) in that the activity was not affected in the Palouse soil. Overall relative toxicity of mixed smokes on soil phosphatase activity is ranked as FO/WP > HC/FO/WP ≥ HC/FO.

Previous data from individual smoke exposures have shown that phosphorus smokes decreased phosphatase activity in Burbank soil to 28-54% immediately after exposure and declined to 0-45% 4 weeks later (Van Voris et al. 1987). A cumulative dose of HC inhibited Burbank soil phosphatase activity to 46% and remained at this level 4 weeks later, whereas Palouse soil was not affected, although it declined to 51% after 4 weeks (Cataldo et al. 1989b). The effect of the single dose of HC or FO smoke was not studied. Results from the mixed-smokes exposure studies have shown that the effects of a cumulative dose of mixed-smoke exposure (HC/FO/WP, FO/WP, or HC/FO) were similar to those of the individual phosphorus or HC smoke. However, a single exposure to mixed smoke HC/FO/WP had less impact than the phosphorus of HC smokes. Both Burbank and Palouse soils were able to fully recover to the unexposed level 4 weeks after exposure. A synergistic effect could not be concluded because of the lack of data on individual FO smokes and limited data on HC smokes.

3.5.3 Soil Nitrifying Bacteria

The process of nitrification or the conversion of NH_4^+ to NO_2^- and NO_2^- to NO_3^- in soil is a microbially mediated process important in the N cycle. Nitrate is more mobile in soil and therefore more available for plant and microbial uptake. *Nitrosomonas sp.*-type microorganisms and *Nitrobacter sp.*-type microorganisms are bacteria that mediate these processes. These two species are sensitive to environmental toxicants. Assaying the nitrifying bacteria in soil exposed to mixed smoke is integral to the assessment of mixed-smoke effects on soil microorganisms and the soil N cycle.

Populations of soil employing HC/FO/WP of soil *Nitrosomonas sp.* were not significantly affected by the exposure to the RF/WS tests (Table 3.55). However, a decline in the population of soil *Nitrobacter sp.* was observed in the Burbank soil in the 2.73 m/s (MS-5) exposure (Table 3.56). Earlier work with FO has demonstrated that it does not significantly affect the soil nitrifying bacteria (Cataldo et al. 1989a). Results with mixed-smoke exposures presented here support this observation that FO may be protective and/or stimulatory to the microbial community.

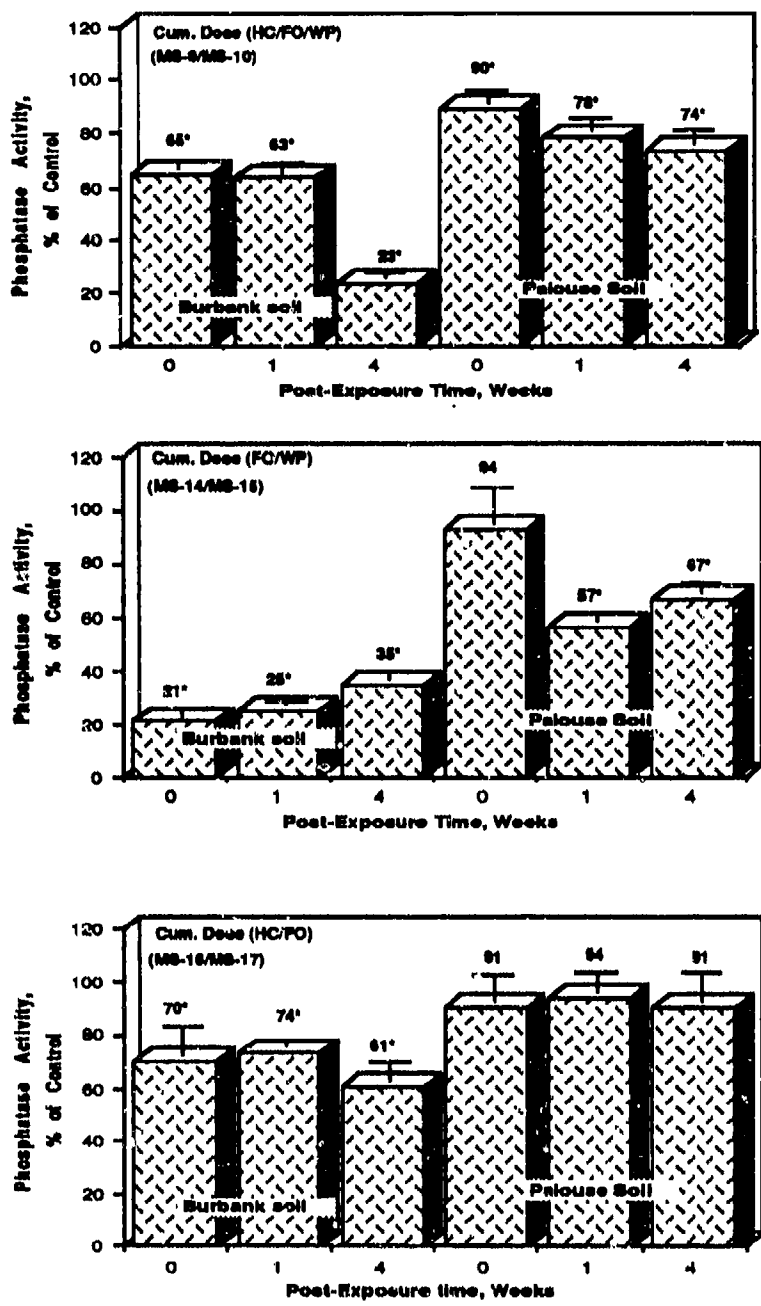

FIGURE 3.21. PHOSPHATASE ACTIVITY (EXPRESSED AS % OF CONTROL) IN SOIL EXPOSED TO CUMULATIVE DOSE MIXED SMOKES. ERROR BARS REPRESENT STANDARD DEVIATIONS, n = 3. *DENOTES SIGNIFICANT DIFFERENCE FROM CONTROLS (UNEXPOSED SOILS) BASED ON STUDENT T-TEST (P<0.05)

TABLE 3.55. EFFECT OF MIXED SMOKES (RANGE-FINDING/WIND SPEED TESTS) ON SOIL *NITROSOMONAS SP.* POPULATION

		Log(MPN Population/g dry wt) (a)							
		Burbank Soil				Palouse Soil			
Post Exposure Time (Weeks)	Test No.-> WS(b)	MS-3 (0.92m/s)	MS-4 (1.83m/s)	MS-5 (2.73m/s)	MS-6 (4.57m/s)	MS-3 (0.92m/s)	MS-4 (1.83m/s)	MS-5 (2.73m/s)	MS-6 (4.57m/s)
0		2.04/1.41	2.45/1.63	2.45/1.42	2.28/2.14	3.48/3.47	3.48/2.46	2.48/2.29	2.65/2.44
1		1.41/1.29	1.82/1.45	1.60/1.50	1.80/1.45	2.67/2.67	2.90/2.49	2.95/2.49	3.02/2.49
4		1.98/1.19	1.77/1.31	1.44/0.73	1.44/1.19	2.44/2.26	2.01/2.01	2.48/2.48	1.48/1.47

- (a) *Nitrosomonas* population in unexposed soil/*Nitrosomonas* population in exposed soil. 95% confidence interval for the 5-replicate, 10-fold dilution most-probable-number technique is ± 0.52 . No significant difference was found between the unexposed and exposed soils based on the Student t-test, ($P \leq 0.05$) on these data.
- (b) WS = wind speed in meter per second.

TABLE 3.56. EFFECT OF MIXED SMOKES (RANGE-FINDING/WIND SPEED TESTS) ON SOIL *NITROBACTER SP.* POPULATION

		Log(MPN population/g dry wt) (a)							
		Burbank Soil				Palouse Soil			
Post Exposure Time (Weeks)	Test No.-> WS(b)	MS-3 (0.92m/s)	MS-4 (1.83m/s)	MS-5 (2.73m/s)	MS-6 (4.57m/s)	MS-3 (0.92m/s)	MS-4 (1.83m/s)	MS-5 (2.73m/s)	MS-6 (4.57m/s)
0		2.86/2.38	1.63/1.52	2.04/1.42	1.63/1.45	2.48/2.47	3.48/2.46	1.47/1.45	2.17/1.67
1		2.46/0.86*	2.13/1.29	1.77/0.92	1.45/1.19	1.67/1.48	1.90/1.67	2.01/1.48	2.23/1.47
4		1.51/1.12	1.5/0.73	2.19/0.38*	1.19/0.38	2.01/1.48	1.48/1.48	1.63/1.23	1.48/1.47

- (a) *Nitrobacter* population in unexposed soil/*Nitrosomonas* population in exposed soil. 95% confidence interval for the 5-replicate, 10-fold dilution most-probable-number technique is ± 0.52 .
- (b) WS = wind speed in meter per second.
- (c) Denotes significant difference from controls (unexposed soils) based on the Student t-test, ($P \leq 0.05$).

Cumulative dose exposures showed no effect on soil *Nitrosomonas sp.* population except at time 0 in the Burbank soil after the MS-16/MS-17 test series (Figure 3.22). Overall relative toxicity of mixed smokes on the soil *Nitrosomonas sp.* population was HC/FO = HC/FO/WP = FO/WP. Soil *Nitrobacter sp.* population was not affected by the cumulative dose exposure to FO/WP (MS-14/MS-15) mixed smoke (Figure 3.23). However, *Nitrobacter sp.* in

both soils decreased after exposure to a cumulative dose of HC/FO/WP (MS-9/MS-10) and HC/FO (MS-16/MS-17) mixed smokes. The most severe inhibition was observed with soils exposed to cumulative dose of HC/FO mixed smokes. Soil *Nitrobacter sp.* populations in both soils were reduced to detection limit. Although Burbank soil showed a sign of recovery, Palouse soil remained inhibited 4 weeks after exposure to HC/FO mixed smokes. Overall relative toxicity of mixed smokes on the soil *Nitrobacter sp.* population was HC/FO > HC/FO/WP > FO/WP.

Studies with individual smoke have shown that phosphorus smoke inhibited soil nitrification potential by lowering soil pH to an unfavorable acidic range; however, no nitrifying bacterial populations were determined in that study (Van Voris et al. 1987). Fog oil exerted no impact on the population of soil nitrifying bacteria (Cataldo et al. 1989a), and a single dose of HC did not affect the *Nitrosomonas spp.*, while it adversely decreased the population of *Nitrobacter* species (Cataldo et al. 1989b). Data from this study show that the two HC-containing mixed smokes, HC/FO/WP and HC/FO, caused a more severe impact on soil nitrifying bacteria than the FO/WP mixed smoke. Nevertheless, their overall effect was not as pronounced as that caused by the cumulative dose of HC smoke exposure. This indicates that interactions of FO and WP with HC may have a positive synergistic effect on the population of soil nitrifying bacteria.

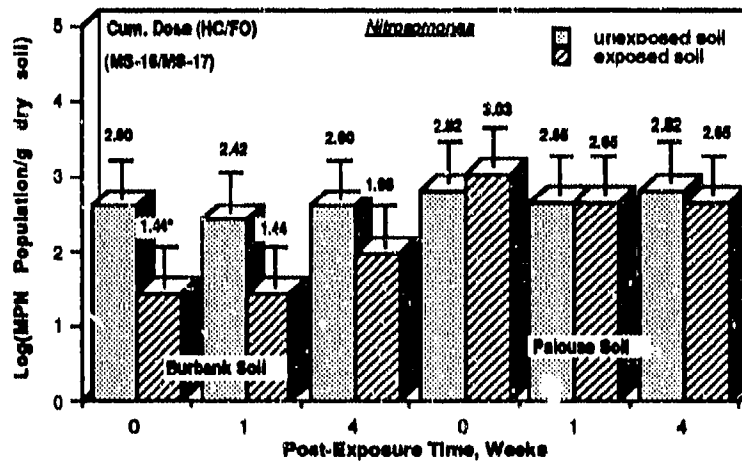
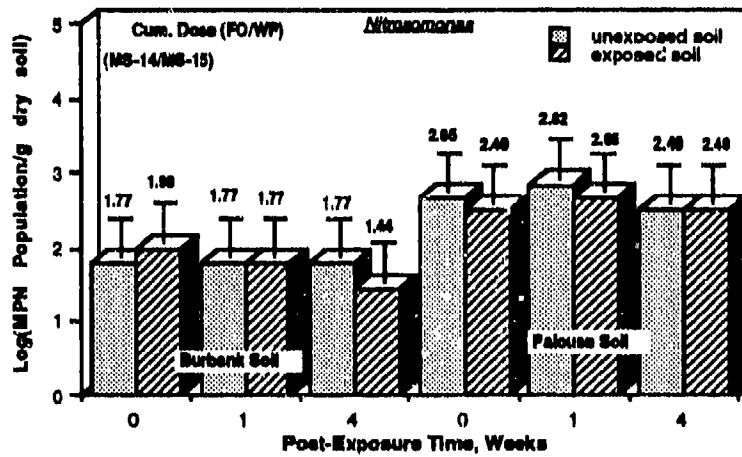
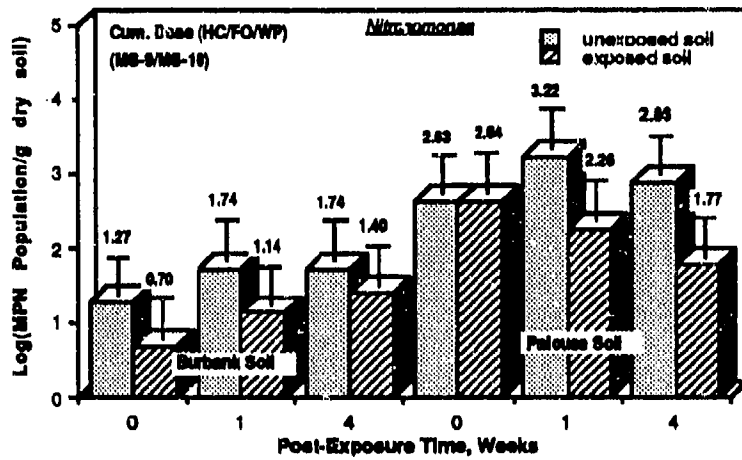

FIGURE 3.22. *NITROSOMONAS SP.* POPULATION IN SOILS EXPOSED TO A CUMULATIVE DOSE OF MIXED SMOKES. ERROR BARS REPRESENT A 95% CONFIDENCE INTERVAL OF ± 0.52 .

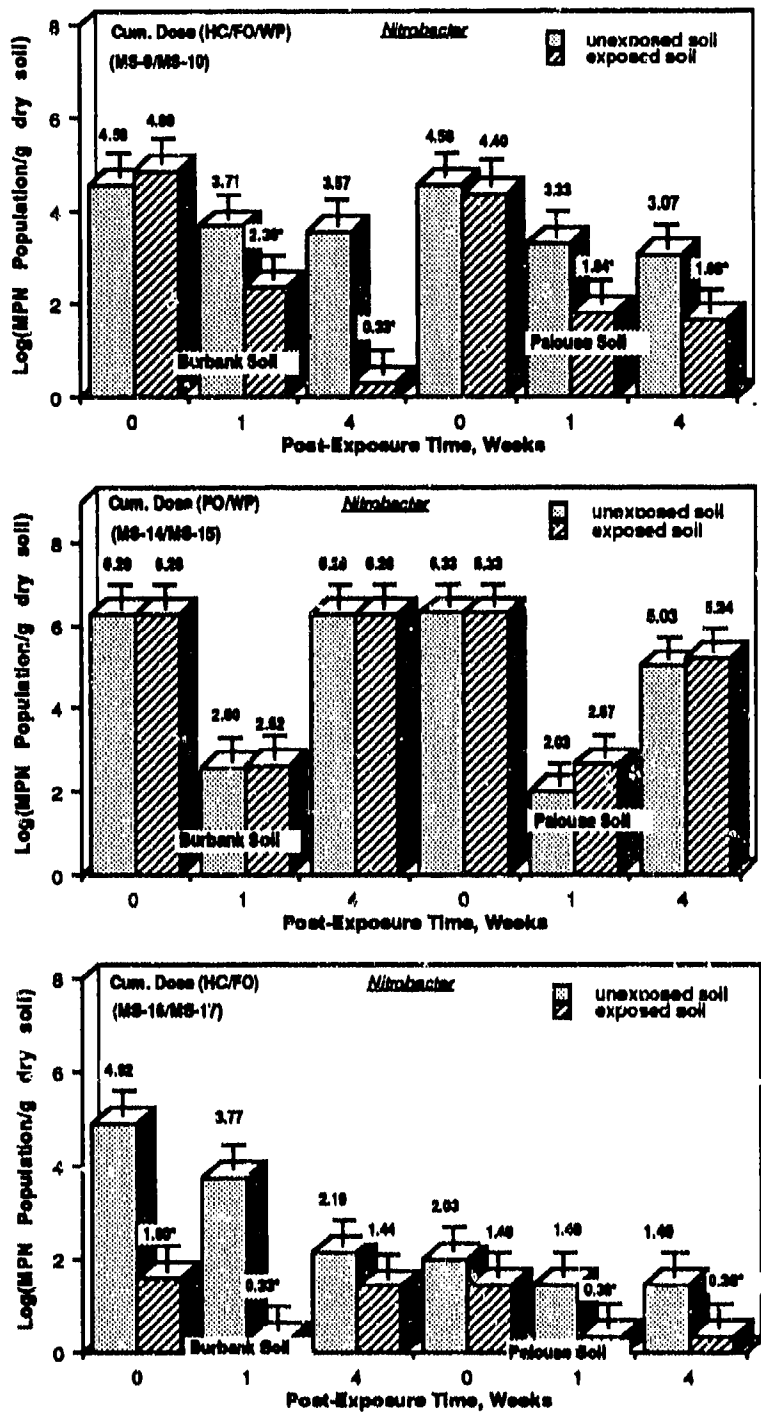

FIGURE 3.23. *NITROBACTER SP.* POPULATION IN SOILS EXPOSED TO A CUMULATIVE DOSE OF MIXED SMOKES. ERROR BARS REPRESENT A 95% CONFIDENCE INTERVAL OF ± 0.52 .

4.0 CONCLUSIONS

The environmental fate and effects of the individual obscurant smokes, red phosphorus/white phosphorus (RP/WP) (Van Voris et al. 1987), fog oil (FO) (Cataldo et al. 1989a), and hexachloroethane (HC) (Cataldo et al. 1989b) previously have been assessed. Of these smokes, only the phosphorus smokes resulted in moderate to severe plant damage from contact toxicity and exhibited moderate residual plant effects. Both HC and P smokes had adverse effects on the functional performance of soil microbial activity. Fog oil had little effect on plants or soil microbes. Significant adverse effects on soil chemistry or soil invertebrates was not observed for any of the smokes. The objective of the present study was to establish whether mixed smoke scenarios, employing these three smokes, could have a synergistic impact on the environs in which they are employed for training. The principal mixed-smoke scenario involved sequential exposure to HC, FO, and WP. Additional scenarios involved use of FO/WP and HC/FO. Air concentrations were set at those levels normally effective in the field, and were 500 to 600 mg/m³ for FO and HC, and 2000 mg/m³ for WP. Exposure durations ranged from 2 to 4 h for each smoke. Thus, effects and/or impacts can be compared with those reported for individual smokes.

The chemistry of the FO and HC smokes following deposition to surfaces was generally consistent with their reported individual behavior. However, with WP, the combustion products or rates of conversion of polyphosphates to phosphate appear to be altered by the presence of FO and HC+FO, resulting in elevated levels of non-phosphate P. This may have influenced the higher than expected toxicity of mixed smokes containing WP. Similarly, there may be a potential interaction of HC derived Cl⁻ with the polyphosphates from WP combustion, which may influence the fate and effects of these mixed smokes.

Deposition velocities for the mixed smoke components P, Zn, and Cl were generally similar to those for single-smoke exposures. Deposition velocities were highest for ponderosa pine and lowest for tall fescue; these ranged from 0.003 to 0.4 cm/s and were dependent on wind speed. Calculated values for mixed-smoke components were similar to those reported previously for RP/WP (Van Voris et al. 1987), FO (Cataldo et al. 1989a), and HC smokes (Cataldo et al. 1989b).

The effects of smoke mixtures on soil chemistry were not judged significant; however, several points are important. The anion/cation balances for soil extracts indicate the likely presence of polyphosphates. Exposed Burbank soils exhibited increases in nitrate and

dissolved organic carbon (DOC). Maxey Flats soil exhibited increases in Al, Fe, and NH_4^+ .

Palouse soil (fresh) exhibited increases in nitrate and NH_4^+ . Yamac soils exhibited increases in Al, Fe, and DOC. Trace metal solubilization in soils exposed to smokes likely results from increased acidity. Fluctuations in nitrogen pools likely result from effects of smoke constituents on microbial populations.

In the RFT/WS test series employing HC/FO/WP, contact phytotoxicity was greater than expected based on published single-smoke exposures noted in the studies above. All plant species exhibited moderate to severe damage at mass loading levels comparable, or less than, those used in single-smoke exposure tests. Plant sensitivity to mixed smokes was bush bean > sagebrush > ponderosa pine > tall fescue. Cumulative dose tests, normally employing 5 to 7 sequential exposures at 2-to 3-day intervals, were terminated after only two exposures because of the higher-than-expected impacts. With the exception of ponderosa pine, all plants were severely impacted on exposure to HC/FO/WP. In alternate scenario tests involving WP/FO, damage to all plants was also severe. Cumulative dose tests using HC/FO resulted in severe damage only to bush bean and sagebrush. Results indicate that much of the phytotoxicity is a result of WP smoke constituents. Gas exchange studies to elicit the effects of smokes on leaf respiration and photosynthesis indicated that an adverse, but transient, effect can be observed, but was most notable with those smokes containing WP. Attempts to resolve the source of phytotoxicity, through application of specific WP smoke constituents indicated that damage can be elicited by both pH and P_2O_5 , but not by long-chain polyphosphates.

Growth and regrowth of exposed tall fescue plants indicated no significant residual effects based on biomass production. Similarly, seeding and growth of tall fescue on soils contaminated with mixed smokes showed no effects on either germination or dry matter production. Although this is contrary to reported effects of RP/WP (Van Voris et al. 1987), soil mass loading levels were lower in the present mixed-smoke studies because of early termination of the cumulative dose test series.

Soils exposed to mixed smokes were evaluated for effects on key microbial processes, including respiration, dehydrogenase activity, phosphatase activity, and nitrification. Soil respiration was reduced in soils exposed to HC- and WP-containing smokes; however, recovery was evident after 4 weeks. Both phosphatase and dehydrogenase activity was depressed following exposure to mixed smokes, but again, recovery was evident after 4 weeks. Although the population of *Nitrosomonas* sp. in soils was not dramatically affected in soils exposed to

mixed smokes, the population of *Nitrobacter sp.* was reduced in Burbank soil. Results indicated that effects were most pronounced for soils exposed to smokes containing HC, and less for soils exposed to WP smokes.

No effects were noted on earthworm survival in soils containing any of the mixed-smoke combinations.

Overall, the major environmental impacts observed with mixed obscurant smokes resulted from combustion products of WP; this observation is consistent with previously reported toxicity resulting from use of individual smokes RP/WP, FO, and HC (Van Voris et al. 1987; Cataldo et al. 1989a, 1989b). It is likely that soils exposed to mixed smokes are most affected by pH, and possibly polyphosphates produced in combustion of phosphorus smokes. Plant effects appear to result principally from the pH of phosphorus smokes and likely P_2O_5 . Plant effects are not persistent based on residual and indirect effect studies. Microbial processes appear to be adversely affected both by Zn associated with HC smoke, and possibly the polyphosphoric acid associated with WP and RP smokes. In general, FO smokes have a beneficial effect on microbial processes.

The question of synergistic effects of mixed-smoke exposures is difficult to address. For physical deposition processes, and thus dose to environmental components, no synergisms were observed. This was particularly true for FO and HC smokes used in combination. However, mixed smokes affected the chemistry of combustion products when WP was present. The presence of either FO or HC constituents in smokes appeared to increase the observed effects, and likely results from a reduction in the rate of polyphosphate conversion to phosphate. This aspect of smoke chemistry is implicated in the anion/cation chemistry of soils, and possibly related to the greater than expected toxicity in plants and soil microbial processes. However, acidity associated with both the HC and WP smokes cannot be eliminated as a basis for the observed biotic and soil effects. The latter would represent an "additive" rather than "synergistic effect" because the only basis for relating dose to effects is mass loading.

5.0 REFERENCES

Alexander, M. 1982. "Most Probable Number Method for Microbial Populations." In: Methods of Soil Analysis, Part 2 (2nd ed.), pp. 815-820., A. L. Page (ed.). American Society of Agronomy, Madison, Wisconsin.

Alexander, M., and F. E. Clark. 1965. "Nitrifying Bacteria." In: Methods of Soil Analysis, Part 2 (1st Ed.), pp. 1477-1483, C. A. Black (ed.). American Society of Agronomy, Madison, Wisconsin.

Anderson, J. P. E. 1982. "Soil Respiration" In: Methods of Soil Analysis, Part 2 (2nd ed.), pp. 831-871, A. L. Page (ed.). American Society of Agronomy, Madison, Wisconsin.

Casida, L. E., Jr. 1967. "Microbial Metabolic Activity in Soil as Measured by Dehydrogenase Determinations." Appl. Environ. Microbiol. 34:630-636.

Cataldo, D. A., T. R. Garland, and R. E. Wildung. 1981. "Foliar Retention and Leachability of Submicron Plutonium and Americium Particles." J. Environ. Qual. 10:31-37.

Cataldo, D. A., et al. 1989a. "Evaluate and Characterize Mechanisms Controlling Transport, Fate and Terrestrial Ecological Effects of Fog Oil Obscurant Smoke." U.S. Army Medical Research and Development Command. Fort Detrick, Frederick, Maryland. AD-A 191207.

Cataldo, D. A., et al. 1989b. "Evaluate and Characterize Mechanisms Controlling Transport, Fate and Terrestrial Ecological Effects of Hexachloroethane Obscurant Smokes." U.S. Army Medical Research and Development Command. Fort Detrick, Frederick, Maryland. AD-A.

Cichowitz, J. J. 1983. "Programmatic Life Cycle Environmental Assessment for Smokes/Obscurants - HC Smoke." Vol. 4 of 5. Environmental Assessment ARCSL-EA-83007. U.S. Army Armament, Munitions and Chemical Command, Aberdeen Proving Ground, Maryland.

Hinds, W. C. 1982. "Aerosol Technology." John Wiley & Sons, New York, New York.

Katz, S., A. Snelson, R. Farlow, R. Welker, and S. Mainer. 1980. "Physical and Chemical Characterization of Fog Oil Smokes and Hexachloroethane Smoke - Final Report on Hexachloroethane Smoke." AD-A 080936. U.S. Army Medical Research and Development Command, Fort Detrick, Frederick, Maryland.

Klein, D. A., L. E. Hersman, N. Nagle, S. Wu, E. Mollitoris, M. Manusco. 1979. "Role of Soil Microorganisms as Indicators and Possible Controlling Factors in Plant Succession Processes on Retorted Shale and Disturbed Soils." In: Rehabilitation Potential and Practice of Colorado Oil Shale Lands, C. W. Cook (ed.). Colorado State University, Fort Collins, Colorado.

- Knapp, E. B., L. F. Elliott, and G. S. Campbell. 1983. "Microbial Respiration and Growth During the Decomposition of Wheat Straw." Soil Biol. Biochem. 15:319-323.
- Ligotke, M. W., D. A. Cataldo, P. Van Voris, and C. A. Novich. 1986. "Analysts Use Wind Tunnel to Study Particle Behavior in the Environment." Res. Develop. 28:(6)82-85.
- Newing, T., and C. Jones. 1987. "U.S. Army Operation Concept for Smoke and Obscurant Employment and Countermeasures." Department of Defense Battlefield Tactics Manual TRADOC PAM 525-3. U.S. Army Smoke Integration Proponency Office, Fort McClellan, Alabama.
- Newing, T., and C. Jones. 1987. "Smoke Operation Field Circular." Department of Defense Battlefield Tactics Manual FC 350-1. U.S. Army Smoke Integration Proponency Office. Fort McClellan, Alabama.
- Moore, A. W., and J. S. Russell. 1972. "Factors Affecting Dehydrogenase Activity as an Index of Soil Fertility." Plant Soil 37:675-682.
- Ramirez-Martinez, J. R. 1968. "Organic Phosphorus Mineralization and Phosphatase Activity in Soils." Folia Microbiol. 13:161-174.
- Rowe, R., R. Todd, and J. Walde. 1977. "Microtechnique for Most-Probable-Number Analysis." Appl. Environ. Microbiol. 33:675-680.
- Schmidt, E. L., and L. W. Belser. 1982. "Nitrifying Bacteria." In: Methods of Soil Analysis, Part 2 (2nd Ed.), pp. 1027-1042, A. L. Page (ed.). American Society of Agronomy, Madison, Wisconsin.
- Sevenich, G. J., and J. S. Fritz. 1983. "Addition of Complexing Agents in Ion Chromatography for Separation of Polyvalent Metal Ions." Anal. Chem. 55:12-16.
- Shinn, J. H., S. A. Martins, P. L. Cederwall, and L. B. Gratt. 1985. "Smoke and Obscurants; A Health and Environmental Effects Data Base. A First-Order, Environmental Screening and Ranking of Army Smokes and Obscurants." UCID-20931. U.S. Army Medical Research and Development Command, Fort Detrick, Frederick, Maryland.
- Skujins, J. 1967. "Extracellular Enzymes in Soil." CRC Crit. Rev. Microbiol. 4:383-421.
- Spanggard, R. J., R. Rewick, T. Chou, R. Wilson, R. T. Podoll, T. Mill, R. Parnas, R. Platz, and D. Roberts. 1985. "Environmental Fate of White Phosphorus/Felt and Red Phosphorus/Butyl Rubber Military Screening Smokes." Draft Final Report. SRI International, Menlo Park, CA. DAMD17-82-C-2320.
- Stevenson, F. J. 1982. "Nitrogen in Agricultural Soils." American Society of Agronomy, Madison, Wisconsin.

Tabatabai, M. A., and J. M. Bremner. 1969. "Use of p-nitrophenyl Phosphate for Assay of Soil Phosphatase Activity." Soil Biol. Biochem. 1:301-307.

Tabatabai, M. A. 1982. "Soil Enzymes." In: Methods of Soil Analysis, Part 2 (2nd ed.), pp. 903-947, A. L. Page (ed.). American Society of Agronomy, Madison, Wisconsin.

Van Voris, P., M. W. Ligojke, K. M. McFadden, S. W. Li, B. L. Thomas, D. A. Cataldo, T. R. Garland, J. K. Fredrickson, R. M. Bean, and D. W. Carlile. 1987. "Evaluate and Characterize Mechanisms Controlling Transport, Fate, and Effects of Army Smokes in the Aerosol Wind Tunnel. Transport, Transformations, Fate, and Terrestrial Ecological Effects of Red Phosphorus-Butyl Rubber and Phosphorus Obscurant Smokes." AD-A-191109. U.S. Army Medical Research and Development Command. Fort Detrick, Frederick, Maryland.

West, N. E., and J. Skujins. 1978. "Summary, Conclusions and Suggestions for Further Research." In: Nitrogen in Desert Ecosystems, pp. 244-253. N. E. West and J. Skujins (eds.). US/IBP Synthesis Series No. 9. Dowden, Hutchinson, & Ross, Inc., Stroudsburg, Pennsylvania.

DISTRIBUTION

PNL-7313
UC-402

No. of
Copies

No. of
Copies

OFFSITE

ONSITE

2 DOE/Office of Scientific and
Technical Information

11 Commander
U.S. Army Biomedical Research
and Development Laboratory
ATTN: SGRD-UBZ-RA
Fort Detrick
Frederick, MD 21707-5010

2 Commander
U. S. Army Medical Research and
Development Command
ATTN: SGRD-RMI-S
Fort Detrick
Frederick, MD 21707-5012

42 Pacific Northwest Laboratory
H. Bolton, Jr.
D. A. Cataldo (25)
J. W. Falco
R. J. Fellows
J. M. Hales
P. C. Hays
S. W. Li
M. W. Ligothe
W. T. Pennell
L. E. Rogers
R. L. Skaggs
P. Van Voris
Publishing Coordination
Technical Report Files (5)