

DTIC FILE COPY

(17)

AD-A216 846

MEMORANDUM REPORT BRL-MR-3794

# BRL

A LARGE-CALIBER,  
HIGH-VELOCITY YAW INDUCER

RICHARD A. PENNEKAMP

NOVEMBER 1989

DTIC  
ELECTE  
JAN 18 1990  
S E D

APPROVED FOR PUBLIC RELEASE; DISTRIBUTION UNLIMITED.

U.S. ARMY LABORATORY COMMAND

BALLISTIC RESEARCH LABORATORY  
ABERDEEN PROVING GROUND, MARYLAND

90 01 16 131

UNCLASSIFIED

SECURITY CLASSIFICATION OF THIS PAGE

REPORT DOCUMENTATION PAGE				Form Approved OMB No. 0704-0188	
1a. REPORT SECURITY CLASSIFICATION <b>UNCLASSIFIED</b>		1b. RESTRICTIVE MARKINGS			
2a. SECURITY CLASSIFICATION AUTHORITY		3. DISTRIBUTION / AVAILABILITY OF REPORT Approved for public release; distribution is unlimited.			
2b. DECLASSIFICATION / DOWNGRADING SCHEDULE					
4. PERFORMING ORGANIZATION REPORT NUMBER(S) BRL-MR-3794		5. MONITORING ORGANIZATION REPORT NUMBER(S)			
6a. NAME OF PERFORMING ORGANIZATION U.S. Army Ballistic Research Laboratory		6b. OFFICE SYMBOL (if applicable) SLCBR-LF	7a. NAME OF MONITORING ORGANIZATION		
6c. ADDRESS (City, State, and ZIP Code) Aberdeen Proving Ground, MD 21005-5066		7b. ADDRESS (City, State, and ZIP Code)			
8a. NAME OF FUNDING / SPONSORING ORGANIZATION U.S. Army Ballistic Research Laboratory		8b. OFFICE SYMBOL (if applicable) SLCBR-DD-T	9. PROCUREMENT INSTRUMENT IDENTIFICATION NUMBER		
8c. ADDRESS (City, State, and ZIP Code) Aberdeen Proving Ground, MD 21005-5066		10. SOURCE OF FUNDING NUMBERS			
		PROGRAM ELEMENT NO. 62618A	PROJECT NO. 1L1 62618AH80	TASK NO.	WORK UNIT ACCESSION NO.
11. TITLE (Include Security Classification) A Large-Caliber, High-Velocity Yaw Inducer (U)					
12. PERSONAL AUTHOR(S) Richard A. Pennekamp					
13a. TYPE OF REPORT Memorandum Report		13b. TIME COVERED FROM _____ TO _____		14. DATE OF REPORT (Year, Month, Day)	15. PAGE COUNT 16
16. SUPPLEMENTARY NOTATION					
17. COSATI CODES			18. SUBJECT TERMS (Continue on reverse if necessary and identify by block number)		
FIELD	GROUP	SUB-GROUP	Yaw Induction		
19	10		155mm Gun System		
			High Velocity		
19. ABSTRACT (Continue on reverse if necessary and identify by block number)					
A method of inducing large yaw values (> 10 degrees) for large-caliber (155mm) high-velocity (> 800 m/s) projectiles that does not damage the recoil system has been researched. This report documents this work. Also included are the results from a limited number of test firings (12) using M549, M825, M864, and M107 projectiles.					
20. DISTRIBUTION / AVAILABILITY OF ABSTRACT <input type="checkbox"/> UNCLASSIFIED/UNLIMITED <input checked="" type="checkbox"/> SAME AS RPT. <input type="checkbox"/> DTIC USERS			21. ABSTRACT SECURITY CLASSIFICATION UNCLASSIFIED		
22a. NAME OF RESPONSIBLE INDIVIDUAL Richard A. Pennekamp		22b. TELEPHONE (Include Area Code) (301)-278-2849		22c. OFFICE SYMBOL SLCBR-LF-A	

DD Form 1473, JUN 86

Previous editions are obsolete.

SECURITY CLASSIFICATION OF THIS PAGE  
UNCLASSIFIED

# Table of Contents

	<u>Page</u>
List of Figures . . . . .	v
I. Introduction . . . . .	1
II. Initial Design Work . . . . .	1
III. A Workable Configuration . . . . .	3
IV. Thoughts for the Improvement and Use of the LCHV Yaw Inducer . . . . .	5
V. Conclusions . . . . .	6
Distribution List . . . . .	15

Accession For	
	<input checked="" type="checkbox"/>
	<input type="checkbox"/>
	<input type="checkbox"/>
	<input type="checkbox"/>
	<input type="checkbox"/>
	<input type="checkbox"/>
	<input type="checkbox"/>
	<input type="checkbox"/>
	<input type="checkbox"/>
	<input type="checkbox"/>

A-1



INTENTIONALLY LEFT BLANK.

## List of Figures

<u>Figure</u>		<u>Page</u>
1	Typical yaw-induction system. . . . .	7
2	Loads caused by yaw inducer. . . . .	7
3	Isometric sketch of Design I. . . . .	8
4	Side view of Design I. . . . .	9
5	Test set-up. . . . .	9
6	Part 2's rotation into the projectile's path. . . . .	10
7	Modifications to Part 1. . . . .	10
8	Design II. . . . .	11
9	Design III. . . . .	11
10	Yaw magnitude variation by using plate inserts. . . . .	12
11	Premature shear-pin breakage. . . . .	13
12	Suggested modifications to Design III. . . . .	14

INTENTIONALLY LEFT BLANK.

## I. Introduction

There are some instances in the developmental testing of projectiles when controlled yaw induction is a requirement. In general, a projectile will have some initial value of yaw at the onset of its flight, but the magnitude may be too small to satisfy the testing requirement. In order to conduct larger-than-normal yaw tests, some method of inducing more yaw must be used.

One method of inducing yaw is to create a region in the projectile's flight path where the applied loads on the projectile are unsymmetric. (Another proven yaw induction technique requires that the projectile be eccentrically balled by the use of mass imbalance.<sup>1</sup> Unfortunately, there are some tests that cannot use this technique because the required projectile alterations are not possible or allowable.) This has been done by using a modified muzzle brake (Figure 1). This configuration induces yaw by creating an unsymmetric flow field for the gun gases resulting in an unsymmetric pressure load on the projectile. This pressure has been found to induce the desired amount of yaw on several occasions.

The previously mentioned method of yaw induction has one serious drawback. When the modified brake is subjected to the gun-gas pressure, it transfers a force and a moment to the gun mount that do not occur under normal operating conditions (Figure 2). If these additional loads are large enough, they will cause catastrophic damage to the gun's recoil system.

This brings us to the purpose of this report. A method of yaw induction that minimizes the recoil-damaging loads has been researched. This report discusses how the yaw inducer functions and how its shape was determined. After a workable configuration was determined, 12 test rounds using four types of 155mm projectiles were fired, some with muzzle velocities greater than 800 m/s. The results of these test firings are documented. Finally, thoughts for improving this device are provided.

## II. Initial Design Work

The criteria for the yaw inducer that were set by the project's sponsor are as follows:

- (1) An experimental projectile to be fired from a 155mm weapon system is required to have a first maximum yaw between 8 and 12 degrees.
- (2) The propelling charge to be used is the M203/M203A1, which should produce a velocity of approximately 826 m/s.
- (3) While testing, the gun elevation angle is to be the largest angle that will be used with this experimental projectile. At present this angle is unknown, but it is estimated to be close to 50 degrees ( $\pm 10$  degrees).

Besides this set of criteria, the Ballistic Research Laboratory (BRL) expressed an

---

<sup>1</sup> C. H. Murphy, "Yaw Induction By Means of Asymmetric Mass Distribution", BRL Memorandum Report No. 2669, August 1976.

interest in being able to vary the amount of induced yaw (from round to round) in a predictable fashion. These requirements made large-caliber high-velocity (LCHV) yaw inducer the logical name for this device.

The initial design for the LCHV yaw inducer is shown in Figure 3. Part 1 is a standard brake that has had its baffles removed. This part is attached to the muzzle of the gun using the original thread-connection system. Part 2 is the part that induces yaw, and is attached to Part 1 by shear pins. The shear pins are the only mechanism keeping Part 2 from falling to the ground. The ledge on Part 1 keeps Part 2 from rotating in a clockwise manner. When the gun barrel is stationary, the yaw inducer is in the position shown in Figure 4.

The LCHV yaw inducer operates in two stages. The first stage occurs between the time of ignition and when the projectile clears the front lip of Part 1 (Figure 3). The second stage begins when the gun gases apply pressure to Part 2. It should be noted that Stage 2 begins before Stage 1 ends. In Stage 1, Part 2 induces yaw in the manner that was discussed in Section I (Figure 1). The difference between the LCHV yaw inducer and traditional yaw inducers occurs in Stage 2. When the LCHV yaw inducer is subjected to the gun-gas pressure, it transfers this load to the shear pins. When this load becomes large enough, the pins break. After the pins are broken, Part 2 is no longer attached to the gun barrel, thus eliminating the additional force and moment (Figure 2) a traditional yaw inducer creates. Hence, the recoil system only experiences the customary recoil loads. Stage 2 is complete when Part 2 impacts the ground and stops moving.

A test program was shot using the LCHV yaw inducer shown in Figure 3. The purpose of the test was to determine the amount of induced yaw generated by this configuration. Because of the cost of the experimental projectile, inert M549 projectiles were used in the initial testing of the LCHV yaw inducer. The M549 was chosen because it was assumed to best simulate the flight characteristics of the experimental projectile. The instrumentation used in this test was a 16mm framing camera, two smear cameras, and a single yaw card (Figure 5). The 16mm camera was used to record the motion of LCHV yaw inducer during the launch cycle. The smear cameras were used to determine velocity, verify projectile integrity, and estimate yaw at those two positions. The yaw card was placed at 34 meters because this is the estimated location of the first-maximum yaw for the M549 projectile at the M203 velocity level. The test plan was to start the firings with a lower-velocity propelling charge (M3A1 Zone 3,  $\approx 270$  m/s). After the data was examined, the next higher-velocity zone would be shot. This pattern was to continue until the design charge (M203/M203A1) was achieved or a failure of the system occurred.

Something was learned soon after this test began. There was a major flaw in the design configuration. As shown in Figure 6, the center of gravity of Part 2 was below the pivot point. When ignition occurred, the gun barrel recoiled with a large acceleration. This large acceleration created an inertial force for Part 2. Because the total inertial force of a body can be assumed to be applied at the center of gravity, the recoil acceleration created a counterclockwise moment centered at the pivot point. This caused the lip of Part 2 (Figure 3) to rotate into the path of the projectile. The projectile then would strike Part 2; the evidence being the engraving marks detected on the front lip of Part 2 caused by the projectile's rotating band.



This design flaw took few iterations to correct. The first attempt to correct this problem was to mechanically restrain the brake from rotating in the counterclockwise direction. Two different restraining systems were tried. Neither system was successful at the required test conditions, both failing at well below the goal. The second approach to correct the problem was to move the pivot point in line with the center of gravity. This was done by attaching angle-iron pieces to Part 1 as shown in Figure 7. The shear pin holes were then placed in the angle irons and new mating holes were drilled in Part 2. After this was done, Part 2 stopped rotating into the flight path of the projectile.

Several projectiles ( $> 10$ ), some before the aforementioned rotation problem was solved and some after, were fired using Design I (Figure 3). Three important results were observed from the acceptable test firings (An acceptable test firing was one where the projectile does not hit Part 2).

First, several shots' induced yaw were high ( $> 10$  degrees). Second, the damage of Part 2 because of impact with the ground was limited to inward bending of the sides. This was a problem, but it did not occur on every shot. When it did occur, it could be corrected at the test site by using a hydraulic jack to push the sides to their original position. Third, the gun-gas pressure created severe outward bending of the sides. This bending problem caused by the gun gases was considered to be so large that a design change was necessary.

To correct the outward-side-bending problem, Part 2 of the original design was modified; Part 1 remained as it is shown in Figure 7. As shown in Figure 8, Design II was different from the first design in the following ways. The side area of Design II was considerably reduced. As a result, the side-bending load, which was proportional to the product of the side area and gun-gas pressure, was reduced. Also, the geometry of the front lip area was simplified. These changes reduced the weight by approximately fifty percent when compared to Design I. This was significant because the size of the shear pins is dependent on the weight of Part 2.

Design II was tested, but the results were mixed. The yaw inducer did not fail structurally. The goal of launching the M549 projectile with the M203 charge was achieved. Unfortunately, the level of induced yaw was not high enough. Four shots were fired at the high velocity and the yaw was never more than 6 degrees. These results, along with the results from Design I, were used to design the next generation of the LCHV yaw inducer.

### III. A Workable Configuration

Figure 9 is the third iteration of the LCHV yaw inducer. It has a front lip similar to Design I and low sides like Design II. Its shear pins are located in line with the center of gravity of Part 2. Design III has a new feature. It has the capability to change the level of induced yaw by varying the height of the sides. This side-height variation is accomplished by using aluminum-plate inserts (Figure 10) that are attached to Part 2.

After Design III was fabricated, a test program was fired. The test included four types of projectiles. The types of projectiles used were M549, M825, M864 and M107. The projectiles were all inert. The propelling charges used were the M203 Zone 8 and the M4A2 Zone 7. The projectile/charge combination for each test round is shown in the table

**Table 1. Design III Test Results**

Rd No.	Projectile Type	Charge/Zone	Yaw Card Location (m)	Yaw (degrees)	Comments
1	M549	M203/8	34	15	premature breakage of pins(PBP) PBP
2	M549	M203/8	34	12	
3	M549	M203/8	34	9	
4	M549	M203/8	34	10	
5	M549	M203/8	34	11	
6	M825	M203/8	34	7	PBP
7	M825	M203/8	34	17	PBP, sides 50.8mm higher
8	M864	M203/8	22	10	PBP
9	M864	M4A2/7	22	7	
10	M107	M4A2/7	34	≈ 0	sides 50.8mm higher
11	M107	M4A2/7	34	≈ 0	
12	M864	M4A2/7	-	no data	gun elevated 28 degrees

of results. The instrumentation used was similar to that shown in Figure 5, except that the yaw card location for the M864 rounds was 22 meters from the muzzle.

Table 1 is a summary to date of the test firings using Design III. The results from Rounds 1-5, which used the M549 projectile, are encouraging. They show yaw at the desired level at the required velocity. Rounds 6 and 7 were shot to see what effect (if any) increasing the side height of Part 2 (Figure 10) would have on the induced yaw level. The side height for Round 7 was 101.2mm, which was twice the height of the standard (no plate) configuration used for Round 6. M825 projectiles with the M203 propelling charge were used. The data indicate that varying the yaw level by varying the side height seems possible. Rounds 8 and 9 are M864 projectiles that used different size propelling charges. Round 8's yaw was greater than Round 9's because of the larger pressure of the M203 charge. This result was expected. Rounds 10 and 11 are both M107's fired at the same velocity. Round 11 used the side plate extensions, but no significant difference in yaw could be measured. Though the yaw card was not positioned at a first-maximum location, it was in a position where differences in yaw levels should be measurable. The M107's gyroscopic stability at this velocity ( $\approx 560$  m/s) is much greater than those of the other projectile types used in this test. The test results for the M107 projectile seem to indicate that inducing yaw at high velocity for this projectile is not possible. Round 12 was the final shot using Design III. It is significantly different from the other shots because the gun was elevated at 28 degrees. The projectile used was an M864, and it was fired with Zone 7 of the M4A2 propelling charge. In order to obtain yaw data, the required yaw card placement was 11 meters above the ground. The firing range was not capable of meeting this requirement, so yaw data were not obtained. The purpose of using the yaw inducer with this particular round was to determine what happened to Part 2 after it separated from Part 1. The results were not good. The rear section (where the shear pins holes are located, Figure 9) of one of the sides bent when Part 2 impacted with the ground. The damage was severe enough that testing could not continue.

Another problem occurred during several shots of this test. The shear pins broke prematurely, due to the following reasons:

(1) For Rounds 1, 2, and 6-8 a 12.7mm (1/2 in) pin was used, and this size was too small to structurally survive the inertial load caused by the recoiling gun tube.

(2) For Rounds 3-5 and 9-12, a 19mm (3/4 in) was used. Round 3 was the first round that used the 19mm pins and they functioned correctly (They broke because of forces created by the gun-gas pressure and not because of the inertial forces). After Round 3 was fired, Part 2 was inspected and the shear pin holes were no longer circular because the loads were large enough to cause the material of Part 2 to yield. This created a problem because the shear pins for every shot that followed Round 3 could move relative to Part 2 at the beginning of recoil. This created a scissoring action that cut the pins before the projectile exited the muzzle.

Because the shear pins did break before projectile exit, Part 2's position relative to the gun tube (Figure 11) varied at the time of yaw induction for each round. This difference of position could create a difference in the amount of induced yaw. By comparing the results of Rounds 4 and 5 (rounds whose pins prematurely broke) to the results of Round 3 (correctly functioning pins), it does not seem to create a considerable difference. Therefore, the results of Rounds 1, 2, 4, and 5 are assumed close to those that would have been obtained by correctly functioning shear pins.

#### **IV. Thoughts for the Improvement and Use of the LCHV Yaw Inducer**

Design III of the LCHV yaw inducer produces the desired amount of yaw. There are certain aspects of the design that need to be changed, and some thoughts about this are now presented.

The most significant problem with Design III is the premature shear-pin breakage. This problem was created when the shape of the holes used to attach the shear pins became noncircular. This situation occurred because the steel used to make Part 2 had a lower bearing-load strength than the aluminum used to make the pins (almost a factor of two smaller). This allowed Part 2's material to yield. One method to correct the yielding of the material is to use a higher strength steel. Another option is to make inserts out of a weaker strength material as shown in Figure 12. After every shot the inserts would be deformed, but Part 2 would remain in its original shape. The inserts could then be replaced and testing could continue. In either case, the shear pin holes should be repositioned to increase the material around them.

The damage that resulted from Round 12 (elevation 28 degrees) may have been prevented by having supports as shown in Figure 12. The actual size and shape of the supports would be in part decided by the location of the gun tube. Reducing the height of sides at the problem area would also help.

The LCHV yaw inducer could be optimized for reduced mass. The bottom plate and

front lip could possibly be thinner, reducing the weight of Part 2. Part 2's inertial force during recoil would then be reduced, which would allow for smaller diameter shear pins.

The LCHV yaw inducer was developed using a research gun mount, not a standard field mount. If a field mount is used with the LCHV yaw inducer, the shear pins may have to be redesigned. The reason is that the recoil acceleration and pressure histories for a field-mount firing may be significantly different than those obtained from a comparable firing using the research mount. If the insert system (Figure 12) is implemented, the shear pin diameters could be varied by changing the inner diameter of the inserts. The holes for the inserts in Part 2 would not have to be changed. This would simplify any required machining.

## V. Conclusions

Research for a yaw induction system which does not create loads that can damage the recoil system has been completed. Test firings using several types of 155mm projectiles at high velocities were done, and yaw values of 10 degrees or more were obtained on several occasions. The ability to vary the amount of induced yaw to fulfill a specific requirement seems possible. Final design considerations have been formulated.

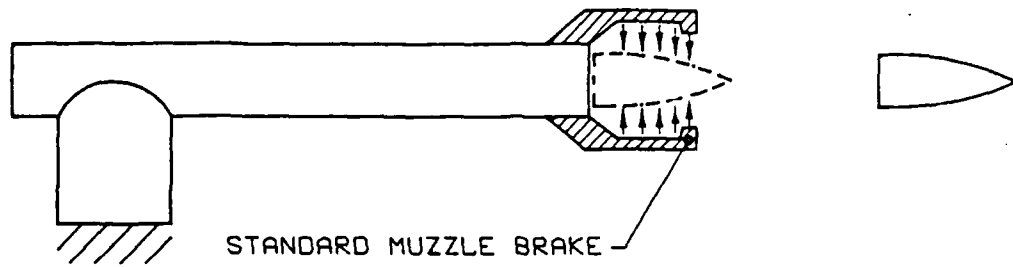

ARROWS REPRESENT GUN-GAS PRESSURE

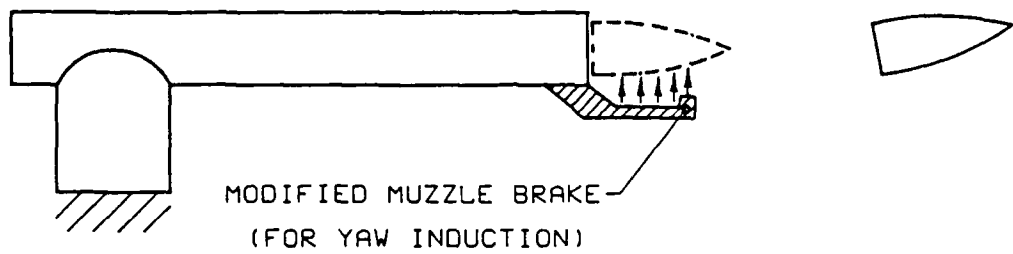

Figure 1. Typical yaw-induction system.

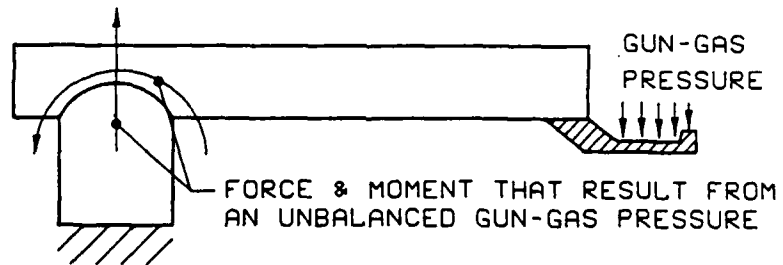
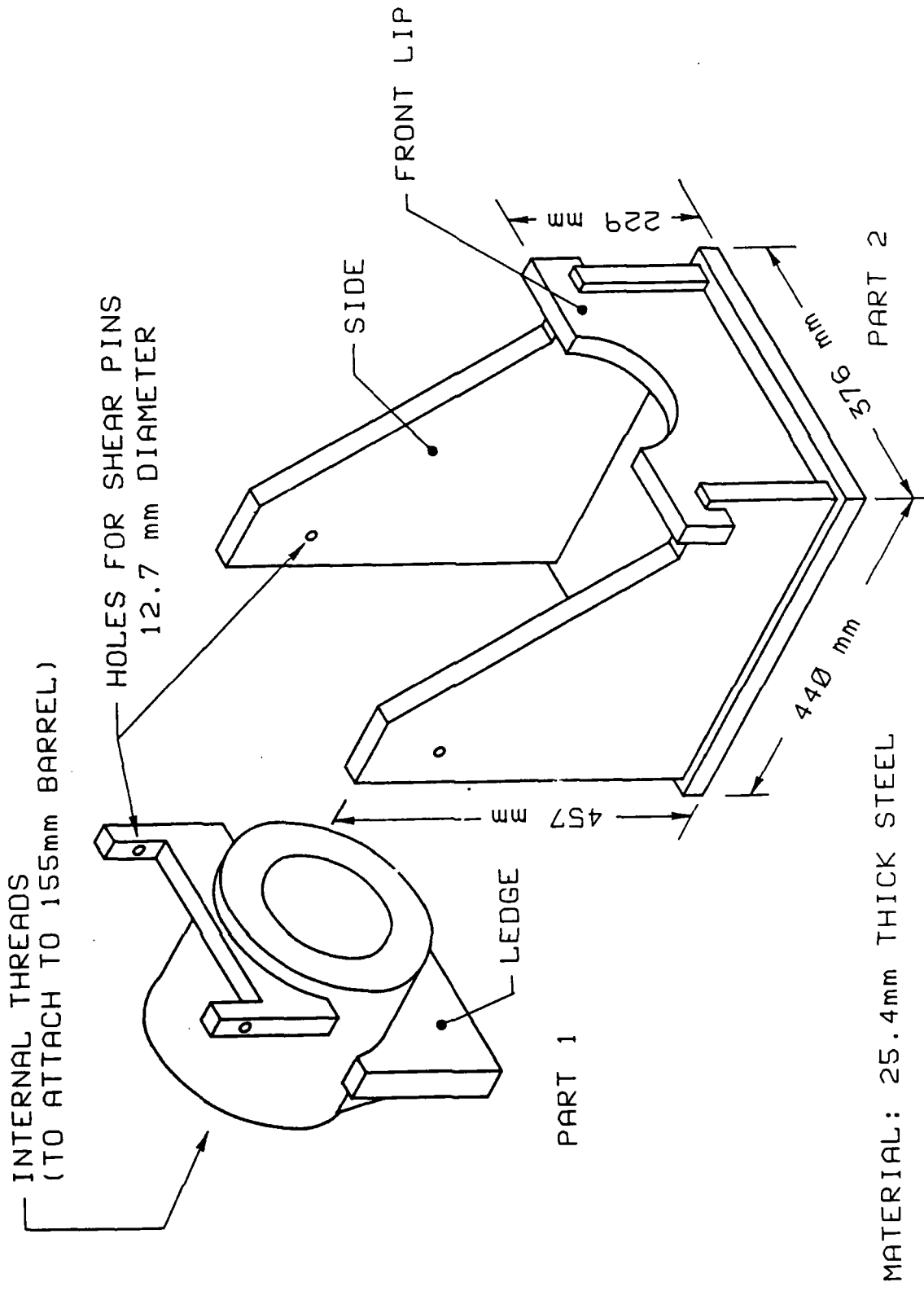

Figure 2. Loads caused by yaw inducer.



MATERIAL: 25.4mm THICK STEEL

Figure 3. Isometric sketch of Design I.

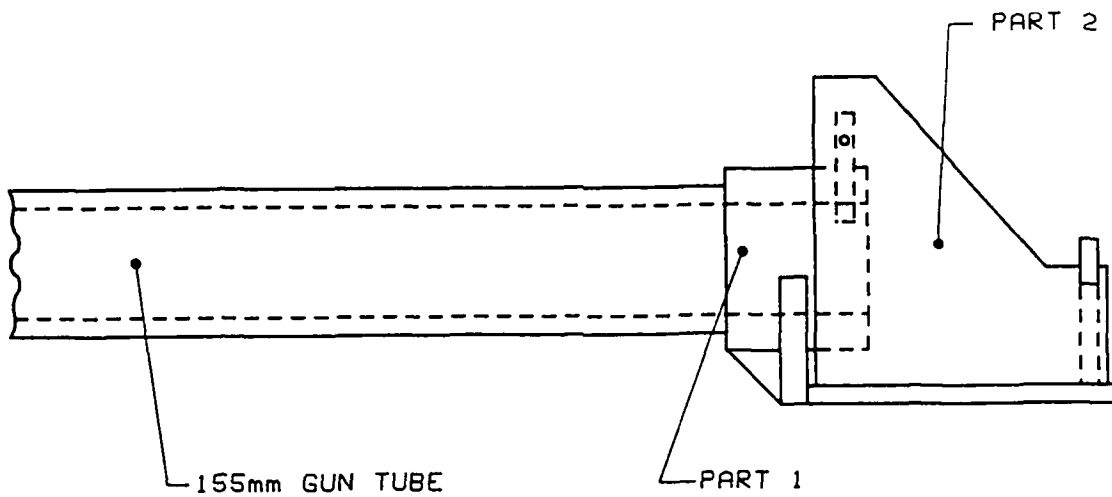

Figure 4. Side view of Design I.

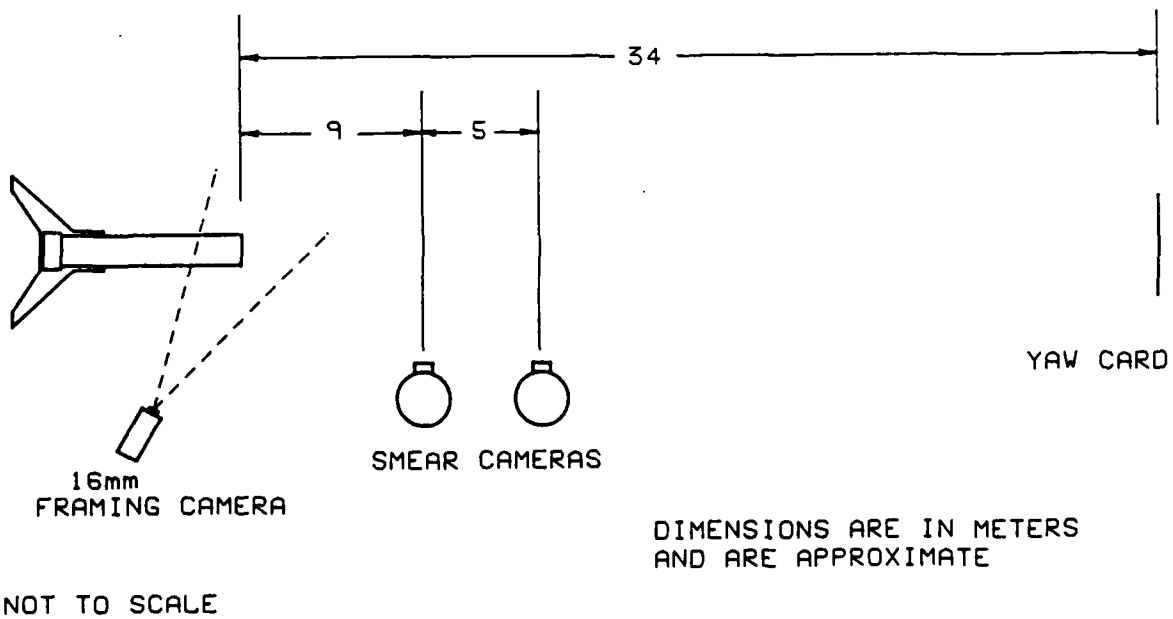

Figure 5. Test set-up.

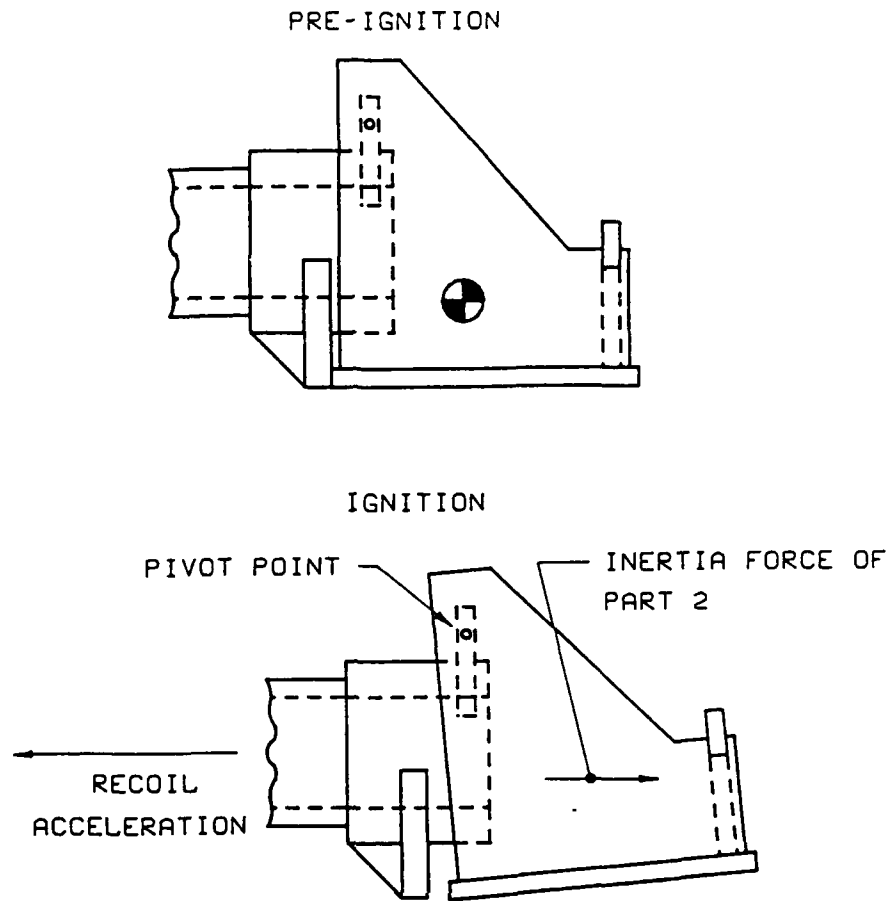

Figure 6. Part 2's rotation into the projectile's path.

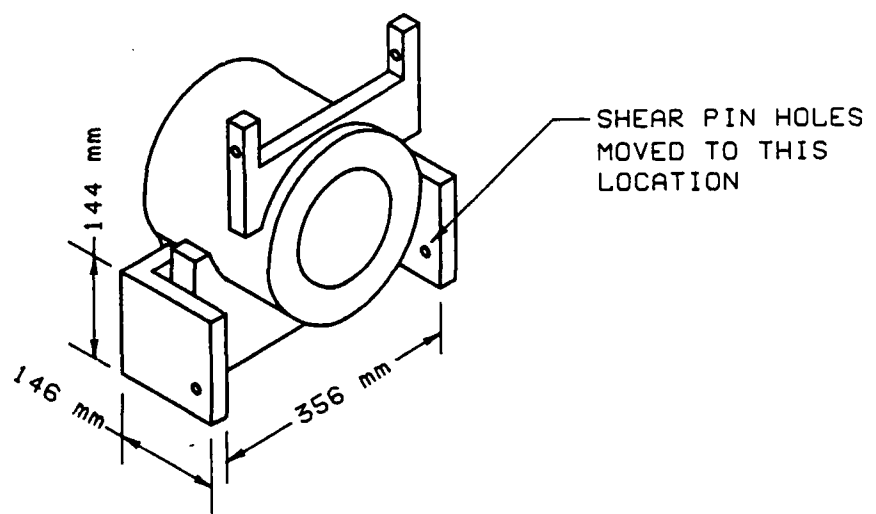

Figure 7. Modifications to Part 1.



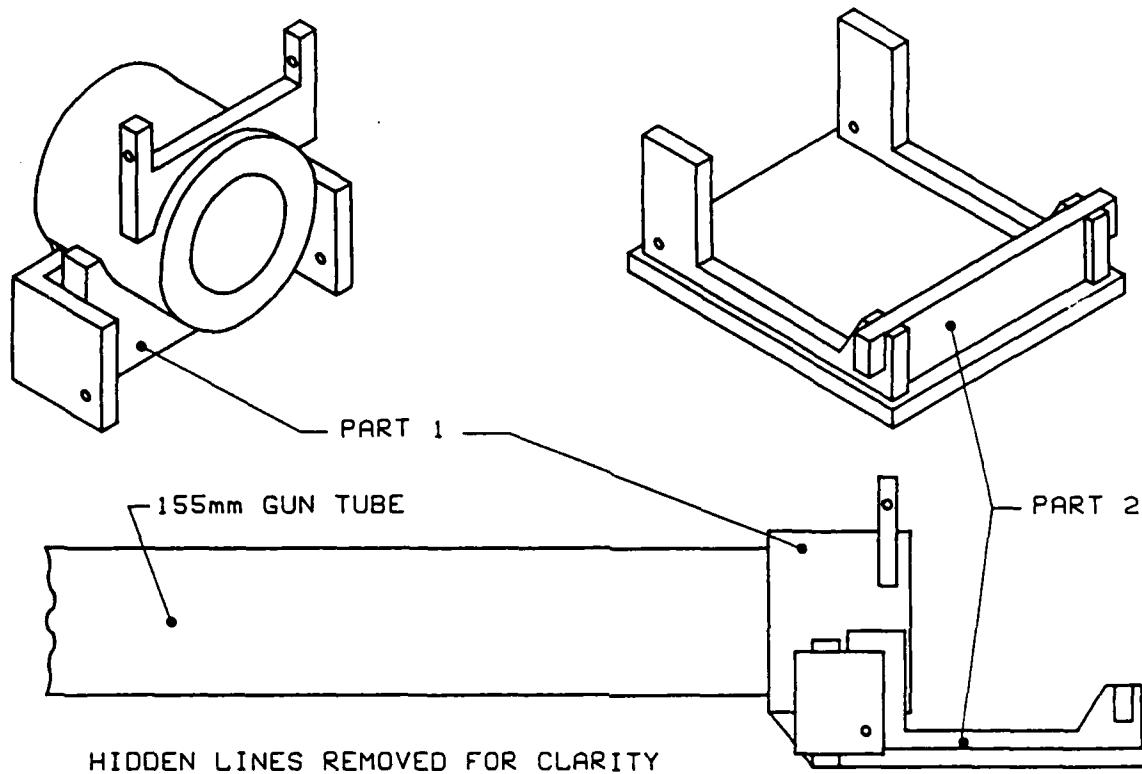

Figure 8. Design II.

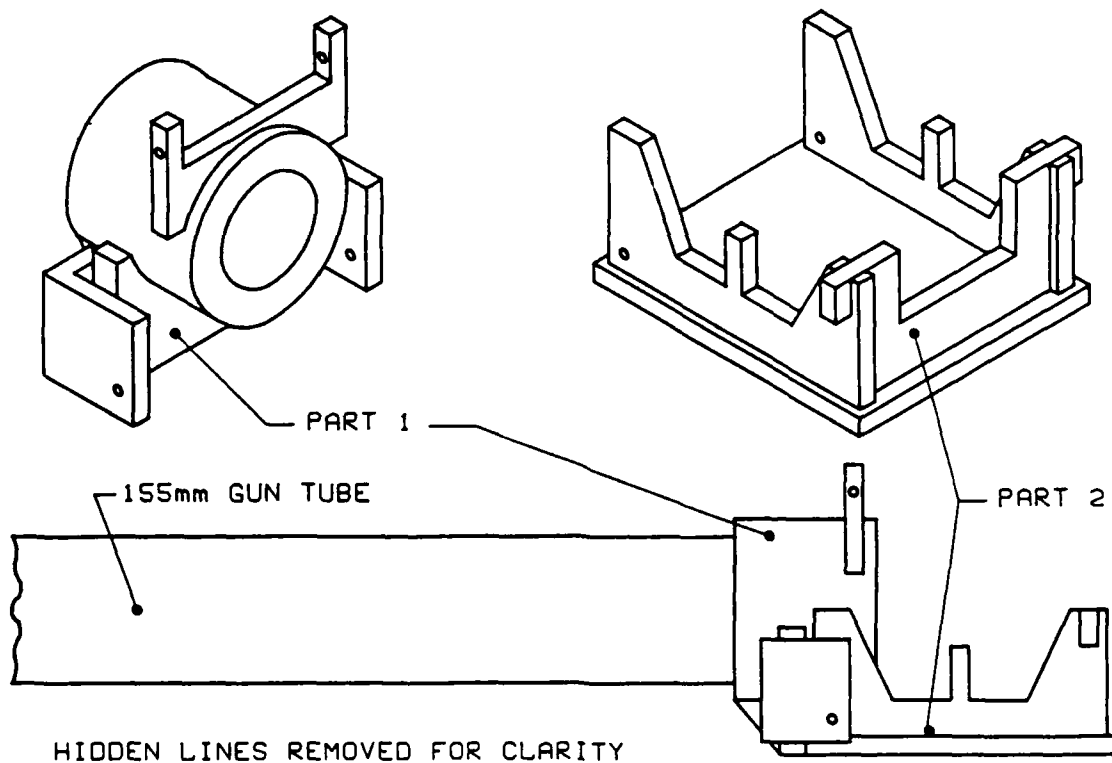
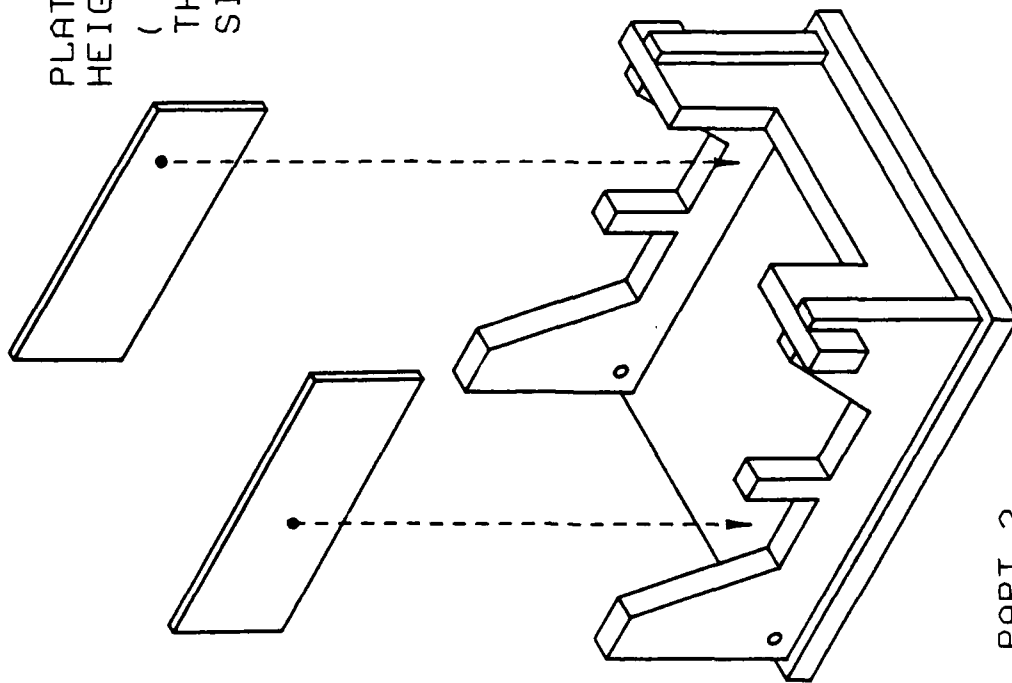

Figure 9. Design III.



PART 2  
DESIGN III

PLATE THICKNESS: 9.5 mm  
 HEIGHT (AS' SEE IN THIS FIGURE): 114mm  
 ( NOTE: HEIGHT OF PART 2'S SIDE IS 50mm.  
 THEREFORE, THE PLATES SHOWN INCREASE THE  
 SIDE HEIGHT BY 64mm.. )

PLATES ARE POSITIONED AS SHOWN  
 AND ARE ATTACHED WITH 1/4" DIA BOLTS

ATTACHMENT LOCATIONS

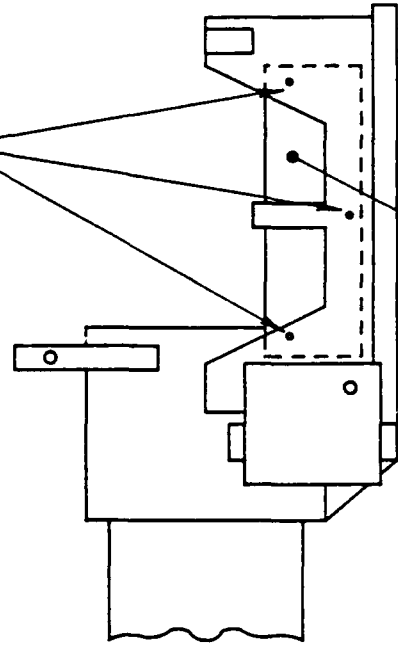

L- PLATE

SIDE VIEW

Figure 10. Yaw magnitude variation by using plate inserts.

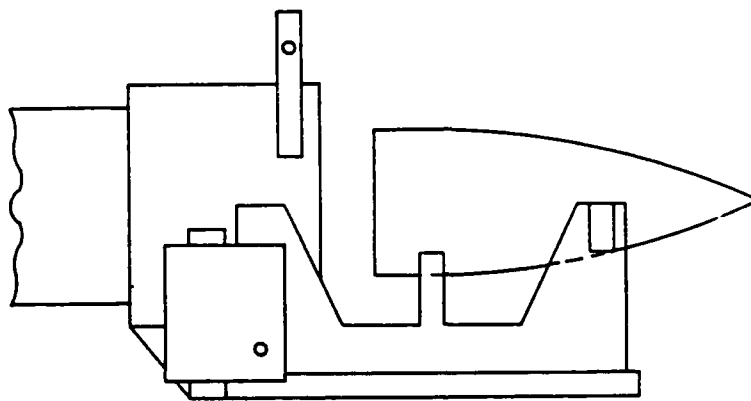
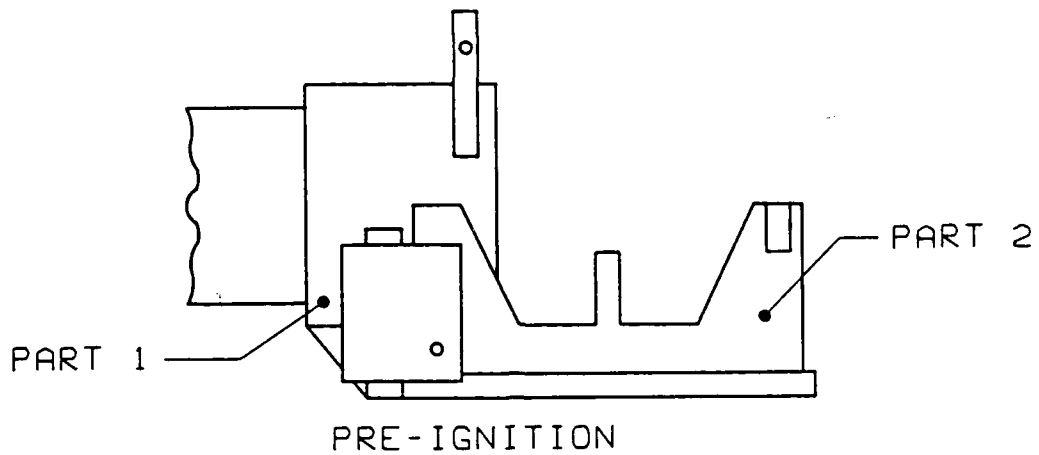

CORRECTLY FUNCTIONING YAW INDUCER  
PART 2 REMAINS ATTACHED TO PART 1 DURING RECOIL

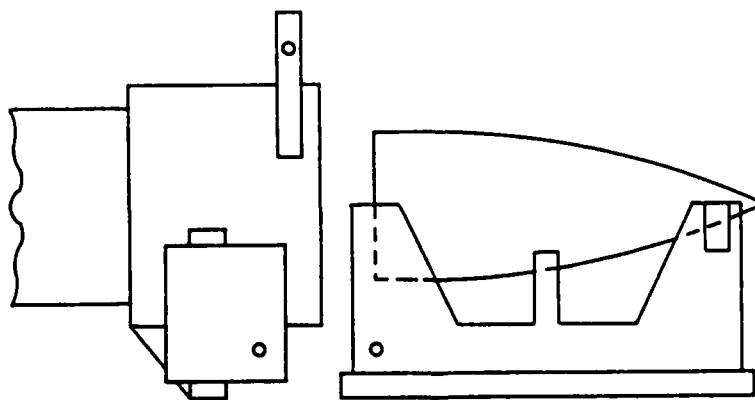

IMPROPERLY FUNCTIONING YAW INDUCER  
SHEAR PINS BREAK; PART 2 REMAINS IN  
PRE-IGNITION LOCATION

**Figure 11. Premature shear-pin breakage.**

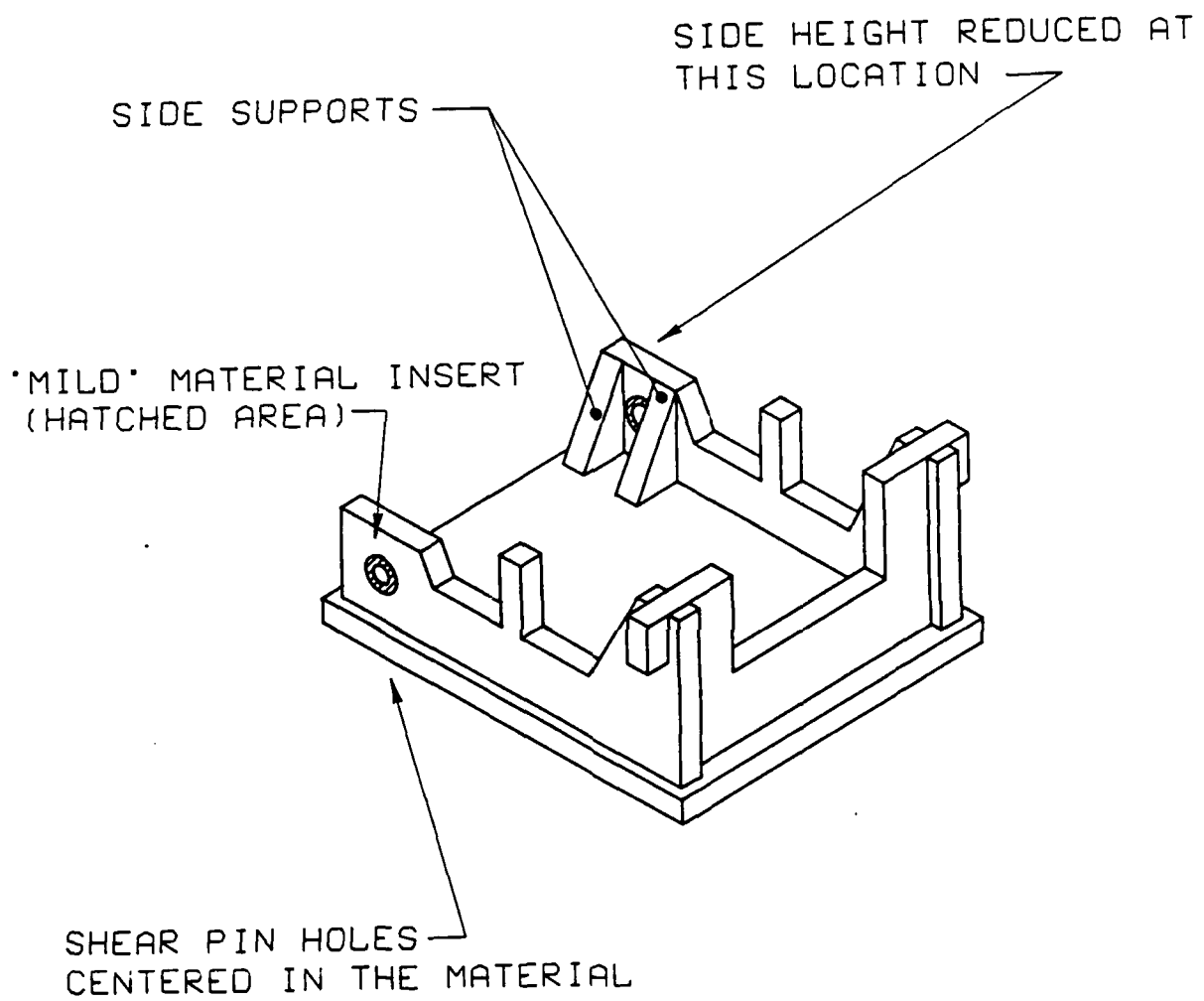

Figure 12. Suggested modifications to Design III.

No of Copies	Organization	No of Copies	Organization
(Unclass., unlimited) 12	Administrator	1	Commander
(Unclass., limited) 2	Defense Technical Info Center		US Army Missile Command
(Classified) 2	ATTN: DTIC-DDA Cameron Station Alexandria, VA 22304-6145		ATTN: AMSMI-RD-CS-R (DOC) Redstone Arsenal, AL 35898-5010
1	HQDA (SARD-TR) WASH DC 20310-0001	1	Commander US Army Tank Automotive Command ATTN: AMSTA-TSL (Technical Library) Warren, MI 48397-5000
1	Commander US Army Materiel Command ATTN: AMCDRA-ST 5001 Eisenhower Avenue Alexandria, VA 22333-0001	1	Director US Army TRADOC Analysis Command ATTN: ATAA-SL White Sands Missile Range, NM 88002-5
1	Commander US Army Laboratory Command ATTN: AMSLC-DL Adelphi, MD 20783-1145	(Class. only) 1	Commandant US Army Infantry School ATTN: ATSH-CD (Security Mgr.) Fort Benning, GA 31905-5660
2	Commander Armament RD&E Center US Army AMCCOM ATTN: SMCAR-MSI Picatinny Arsenal, NJ 07806-5000	(Unclass. only) 1	Commandant US Army Infantry School ATTN: ATSH-CD-CSO-OR Fort Benning, GA 31905-5660
2	Commander Armament RD&E Center US Army AMCCOM ATTN: SMCAR-TDC Picatinny Arsenal, NJ 07806-5000	(Class. only) 1	The Rand Corporation P.O. Box 2138 Santa Monica, CA 90401-2138
1	Director Benet Weapons Laboratory Armament RD&E Center US Army AMCCOM ATTN: SMCAR-LCB-TL Watervliet, NY 12189-4050	1	Air Force Armament Laboratory ATTN: AFATL/DLODL Eglin AFB, FL 32542-5000
1	Commander US Army Armament, Munitions and Chemical Command ATTN: SMCAR-ESP-L Rock Island, IL 61299-5000		<u>Aberdeen Proving Ground</u> Dir, USAMSAA ATTN: AMXSY-D AMXSY-MP, H. Cohen Cdr, USATECOM ATTN: AMSTE-TO-F Cdr, CRDEC, AMCCOM ATTN: SMCCR-RSP-A SMCCR-MU SMCCR-MSI Dir, VLAMO ATTN: AMSLC-VL-D
1	Commander US Army Aviation Systems Command ATTN: AMSAV-DACL 4300 Goodfellow Blvd. St. Louis, MO 63120-1798		
1	Director US Army Aviation Research and Technology Activity Ames Research Center Moffett Field, CA 94035-1099		

DISTRIBUTION

<u>No. of Copies</u>	<u>Organization</u>
3	Commander Armament RD&E Center US Army AMCCOM ATTN: SMCAR-AET-A (E.F. Brown) (S. Kahn) (R. Kline) Picatinny Arsenal, NJ 07806-5000
6	Commander US Army Yuma Proving Ground ATTN: STEYP-MTW (K. Price) (J. Kuger) (J. Dominquez) (R. Fillman) (J. Peters) (J. Hall) Yuma, AZ 85365
3	Commander US Army Dugway Proving Ground ATTN: STEDP-MT (Mr. Travers) (Mr. McAllister) (Mr. DeWitt) Dugway, UT 84022
1	Sandia National Laboratories Division 1551 ATTN: Mr. A. Hodapp Albuquerque, NM 87185

Aberdeen Proving Ground

Commander, CRDEC, AMCCOM  
ATTN: SMCCR-RSP-A  
(Miles C. Miller)

USER EVALUATION SHEET/CHANGE OF ADDRESS

This Laboratory undertakes a continuing effort to improve the quality of the reports it publishes. Your comments/answers to the items/questions below will aid us in our efforts.

1. BRL Report Number MR-3794 Date of Report November 1989

2. Date Report Received \_\_\_\_\_

3. Does this report satisfy a need? (Comment on purpose, related project, or other area of interest for which the report will be used.) \_\_\_\_\_

4. How specifically, is the report being used? (Information source, design data, procedure, source of ideas, etc.) \_\_\_\_\_

5. Has the information in this report led to any quantitative savings as far as man-hours or dollars saved, operating costs avoided or efficiencies achieved, etc? If so, please elaborate. \_\_\_\_\_

6. General Comments. What do you think should be changed to improve future reports? (Indicate changes to organization, technical content, format, etc.) \_\_\_\_\_

CURRENT  
ADDRESS

\_\_\_\_\_  
Name

\_\_\_\_\_  
Organization

\_\_\_\_\_  
Address

\_\_\_\_\_  
City, State, Zip

7. If indicating a Change of Address or Address Correction, please provide the New or Correct Address in Block 6 above and the Old or Incorrect address below.

OLD  
ADDRESS

\_\_\_\_\_  
Name

\_\_\_\_\_  
Organization

\_\_\_\_\_  
Address

\_\_\_\_\_  
City, State, Zip

(Remove this sheet, fold as indicated, staple or tape closed, and mail.)

----- FOLD HERE -----

Director  
U.S. Army Ballistic Research Laboratory  
ATTN: SLCBR-DD-T  
Aberdeen Proving Ground, MD 21005-5066



NO POSTAGE  
NECESSARY  
IF MAILED  
IN THE  
UNITED STATES

OFFICIAL BUSINESS

**BUSINESS REPLY MAIL**  
FIRST CLASS PERMIT NO 12062 WASHINGTON, DC  
POSTAGE WILL BE PAID BY DEPARTMENT OF THE ARMY

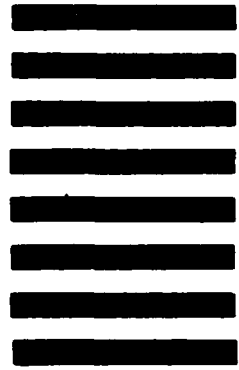

Director  
U.S. Army Ballistic Research Laboratory  
ATTN: SLCBR-DD-T  
Aberdeen Proving Ground, MD 21005-9989

----- FOLD HERE -----