

AD-A210 965

TACTICAL RECONNAISSANCE FOR THE  
HEAVY BRIGADE COMMANDER:  
HOW MUCH IS NOT ENOUGH?

A Monograph

by

Major Guy C. Swan, III

Armor

DTIC  
ELECTE  
AUG 09 1989  
S D D



School of Advanced Military Studies  
United States Army Command and General Staff College  
Fort Leavenworth, Kansas

First Term AY 88-89

Approved for Public Release; Distribution is Unlimited

## REPORT DOCUMENTATION PAGE

Form Approved  
OMB No. 0704-0188

1a. REPORT SECURITY CLASSIFICATION UNCLASSIFIED			1b. RESTRICTIVE MARKINGS		
2a. SECURITY CLASSIFICATION AUTHORITY			3. DISTRIBUTION / AVAILABILITY OF REPORT Approved for public release; distribution is unlimited.		
2b. DECLASSIFICATION / DOWNGRADING SCHEDULE			5. MONITORING ORGANIZATION REPORT NUMBER(S)		
4. PERFORMING ORGANIZATION REPORT NUMBER(S)			7a. NAME OF MONITORING ORGANIZATION		
6a. NAME OF PERFORMING ORGANIZATION School of Advanced Military (continued on rear)		6b. OFFICE SYMBOL (if applicable) ATZL-SWV	7b. ADDRESS (City, State, and ZIP Code)		
6c. ADDRESS (City, State, and ZIP Code) Fort Leavenworth, KS 66027-6900			9. PROCUREMENT INSTRUMENT IDENTIFICATION NUMBER		
8a. NAME OF FUNDING / SPONSORING ORGANIZATION		8b. OFFICE SYMBOL (if applicable)	10. SOURCE OF FUNDING NUMBERS		
8c. ADDRESS (City, State, and ZIP Code)			PROGRAM ELEMENT NO.	PROJECT NO.	TASK NO.
			WORK UNIT ACCESSION NO.		
11. TITLE (Include Security Classification) TACTICAL RECONNAISSANCE FOR THE HEAVY BRIGADE COMMANDER: How Much is Not Enough? (U)					
12. PERSONAL AUTHOR(S) SWAN, GUY C. III, MAJOR, US ARMY					
13a. TYPE OF REPORT MONOGRAPH		13b. TIME COVERED FROM _____ TO _____		14. DATE OF REPORT (Year, Month, Day) 1988 December 14	15. PAGE COUNT 60 pages
16. SUPPLEMENTARY NOTATION					
17. COSATI CODES			18. SUBJECT TERMS (Continue on reverse if necessary and identify by block number)		
FIELD	GROUP	SUB-GROUP	Organizational design, Brigade organization, tactical Reconnaissance, Cavalry, Division, organization, Operations, Doctrine, Training, (continued on rear)		
19. ABSTRACT (Continue on reverse if necessary and identify by block number) To make decisions and to synchronize all available resources properly, the brigade commander requires timely and accurate intelligence and combat information. This monograph examines the issues surrounding the absence of an organic tactical reconnaissance element at brigade level and its effect on the brigade commander's decisionmaking and synchronization effort. The monograph seeks to determine whether an organic brigade reconnaissance element is required by using the following methodology. It first examines the theoretical constructs regarding intelligence and reconnaissance put forth by several military theorists. Having established a theoretical foundation, an historical survey traces the evolution of brigade reconnaissance from World War II to the present. Then the current brigade organization, operational doctrine, and reconnaissance doctrine are reviewed and assessed. To determine whether US organization adheres to internationally accepted norms regarding brigade-level reconnaissance, a comparison is made with several (continued on rear)					
20. DISTRIBUTION / AVAILABILITY OF ABSTRACT <input checked="" type="checkbox"/> UNCLASSIFIED/UNLIMITED <input type="checkbox"/> SAME AS RPT. <input type="checkbox"/> DTIC USERS			21. ABSTRACT SECURITY CLASSIFICATION UNCLASSIFIED		
22a. NAME OF RESPONSIBLE INDIVIDUAL GUY C. SWAN III			22b. TELEPHONE (Include Area Code) 913-684-2138	22c. OFFICE SYMBOL ATZL-SWV	

UNCLASSIFIED

Section 6a continued-

US Army Command and General Staff College.

Section 18 continued-

AirLand Battle, Scouts, Counterreconnaissance, Intelligence.

Section 19 continued-

foreign armies. Finally, an analysis is made of contemporary studies, initiatives, and field expedients aimed at improving brigade tactical reconnaissance to determine if they are consistent with the perspectives outlined above. The paper concludes that, indeed, tactical reconnaissance is crucial to the brigade commander's decisionmaking and synchronization effort and that he needs an organic reconnaissance element responsive to his requirements. Further, in a constrained manpower and equipment environment the proper unit for this task is a light reconnaissance company. For the future, the monograph suggests a possible company organization that is essentially lighter in structure than most traditional cavalry troops and which emphasizes the principle of stealth and secrecy in its reconnaissance operations.

**Tactical Reconnaissance for the Heavy Brigade Commander:  
How Much is Not Enough?**

**Major Guy C. Swan III  
Armor**

**School of Advanced Military Studies  
US Army Command and General Staff College  
Fort Leavenworth, Kansas**

14 December 1988

Accession For	
NTIS CRA&I	<input checked="" type="checkbox"/>
DTIC TAB	<input type="checkbox"/>
Unannounced	<input type="checkbox"/>
Justification	
By	
Distribution /	
Availability Codes	
Dist	Avail and/or Special
A-1	

Approved for public release; distribution is unlimited.



School of Advanced Military Studies  
Monograph Approval

Name of Student: Major Guy C. Swan III  
Title of Monograph: Tactical Reconnaissance for the Heavy Brigade  
Commander: How Much is Not Enough?

Approved by:

Robert M. Epstein Monograph Director  
Robert M. Epstein, Ph.D.

L. D. Holder Director, School of  
Colonel L. D. Holder, MA Advanced Military  
Studies

Philip J. Brookes Director, Graduate  
Philip J. Brookes, Ph.D. Degree Programs

Accepted this 14th day of January 1989.

## **ABSTRACT**

**TACTICAL RECONNAISSANCE FOR THE HEAVY BRIGADE COMMANDER:  
HOW MUCH IS NOT ENOUGH** by Major Guy C. Swan III, USA, 60 pages.

To make decisions and to synchronize all available resources properly, the brigade commander requires timely and accurate intelligence and combat information. This monograph examines the issues surrounding the absence of an organic tactical reconnaissance element at brigade level and its effect on the brigade commander's decisionmaking and synchronization effort.

The monograph seeks to determine whether an organic brigade reconnaissance element is required by using the following methodology. It first examines the theoretical constructs regarding intelligence and reconnaissance put forth by several military theorists. Having established a theoretical foundation, an historical survey traces the evolution of brigade reconnaissance from World War II to the present. Then the current brigade organization, operational doctrine, and reconnaissance doctrine are reviewed and assessed. To determine whether US organization adheres to internationally accepted norms regarding brigade-level reconnaissance, a comparison is made with several foreign armies. Finally, an analysis is made of contemporary studies, initiatives, and field expedients aimed at improving brigade tactical reconnaissance to determine if they are consistent with the perspectives outlined above.

The paper concludes that, indeed, tactical reconnaissance is crucial to the brigade commander's decisionmaking and synchronization effort and that he needs an organic reconnaissance element responsive to his requirements. Further, in a constrained manpower and equipment environment the proper unit for this task is a light reconnaissance company. For the future, the monograph suggests a possible company organization that is essentially lighter in structure than most traditional cavalry troops and which emphasizes the principle of stealth and secrecy in its reconnaissance operations.

## TABLE OF CONTENTS

I.	INTRODUCTION.....	1
II.	THEORETICAL CONSTRUCTS REGARDING RECONNAISSANCE.....	3
III.	HISTORICAL PERSPECTIVE.....	5
IV.	A SURVEY OF BRIGADE ORGANIZATIONAL AND OPERATIONAL DOCTRINE.....	12
V.	BRIGADE RECONNAISSANCE DOCTRINE.....	15
VI.	BRIGADE-LEVEL RECONNAISSANCE FORCES OF FOREIGN ARMIES.....	21
VII.	CONTEMPORARY STUDIES, INITIATIVES, AND FIELD EXPEDIENT SOLUTIONS.....	29
VIII.	CONCLUSIONS AND RECOMMENDATIONS FOR THE FUTURE.....	35
	APPENDIX A: Task Organization, Combat Command A, 28 August 1944.....	39
	APPENDIX B: Proposed ROAD Division with Organic Reconnaissance Company.....	40
	APPENDIX C: Division 86 Brigade HHC with Organic Scout Platoon.....	41
	APPENDIX D: Proposed Brigade Reconnaissance Company.....	42
	ENDNOTES.....	43
	BIBLIOGRAPHY.....	50

## I. INTRODUCTION

To make decisions and synchronize all available resources in a manner which focuses combat power, the heavy brigade commander requires timely and accurate intelligence and combat information. Reconnaissance is crucial to the information gathering effort providing the commander with essential information about the enemy and the terrain. If we accept this premise, then why does today's brigade commander lack his own organic reconnaissance element? This monograph examines the issues surrounding the absence of a dedicated tactical reconnaissance unit at brigade level and its effect on the commander's decisionmaking and synchronization effort.

The brigade's synchronization effort begins with the commander's decisionmaking process. The effectiveness of that decisionmaking rests on the commander's own ability to articulate his key information needs and on the efficiency with which the intelligence battlefield operating system is able to fill those vital information requirements.

The brigade commander's ability to conduct aggressive reconnaissance as part of the overall intelligence collection process is clearly recognized as crucial to mission accomplishment. The data coming out of unit rotations at the National Training Center (NTC) indicate an undeniable correlation between successful operations and successful reconnaissance.<sup>1</sup> Unfortunately,

observations at the NTC and comments by field commanders throughout the army indicate an inability of our...brigades to routinely conduct adequate reconnaissance of the battlefield; provide adequate force security; and defeat enemy reconnaissance forces. (In short,) our brigade maneuver forces are not winning the reconnaissance and security battle.<sup>2</sup>

Further, according to TRADOC commander, General Maxwell Thurman:

Several studies and recent NTC experience reveal



that our brigade and battalion task forces are deficient in conducting reconnaissance, surveillance, and counterreconnaissance.<sup>3</sup>

Under the Army of Excellence (AOE) force structure, brigades assigned to heavy divisions lack organic reconnaissance elements dedicated to the commander. The problem this creates is that the redundancy that could be achieved by "layering" reconnaissance forces throughout the battlefield in a manner contributing to a sequential and complementary reconnaissance handover from division cavalry (or even corps regimental cavalry) down to battalion scouts is not possible. The resultant gap also forces the brigade commander to rely on combat information gathered by other echelons of command; information which may or may not support his specific synchronization effort.

Before we proceed it is important to do two things: identify the key terms and concepts that will be used frequently and narrow the scope of the monograph.

Reconnaissance, surveillance, and target acquisition (RSTA) together represent a system of means by which the brigade commander collects information he needs to conduct the battle.<sup>4</sup> The term *reconnaissance* refers to the actions of ground and aerial elements to obtain information about the enemy and the terrain by visual observation upon which commanders can base plans, decisions, and orders.<sup>5</sup>

*Surveillance* is a more systematic and continuous observation of an area in order to obtain information and can be conducted by visual, electronic, or other means. Similarly, *target acquisition* refers to actions taken to detect, identify, and locate targets so fires can be brought to bear on them. This can also be accomplished by visual or electronic means.

*Electronic warfare* is the use of electromagnetic energy to determine, exploit, reduce, or prevent hostile use of the electromagnetic spectrum in order to protect friendly use thereof.

*Intelligence* is the product resulting from the collection, evaluation, analysis, integration, and interpretation of all available information concerning an enemy force, foreign nations, or areas of operations and which is immediately or potentially significant to military planning and operations. *Combat information*, on the other hand, is unevaluated highly perishable information that is forwarded immediately to the commander. Extensive processing into tactical intelligence would prevent its timely use.

For the purposes of our study RSTA, combined with intelligence and electronic warfare (IEW), make up the intelligence battlefield operating system.

*Security operations* are those combat activities designed to obtain information about the enemy and provide reaction time, maneuver space, and protection to the main body of friendly forces. Though somewhat beyond the scope of this paper, units concerned with reconnaissance often have supplementary security responsibilities as well.

In order to narrow the scope of the monograph our primary area of concentration will be on the intelligence battlefield operating system as it pertains to the AOE heavy brigade with special emphasis on the role of ground reconnaissance at that level. As the concepts and definitions above indicate, reconnaissance cannot be analyzed in isolation but must be examined within the overall context of the RSTA system. Though the focus of the problem is on an organizational issue, it must be clearly understood that there are doctrinal, training, and leader development components of the problem as well. These will be addressed as appropriate throughout.

## II. THEORETICAL CONSTRUCTS REGARDING RECONNAISSANCE

The gathering of information about the enemy and the terrain has always represented an important aspect of military theory. The classical theorists, to varying degrees, discuss intelligence gathering

and reconnaissance as vital preliminary activities to military operations.

Sun Tzu provides some cogent ideas on reconnaissance in his *Art of War*. The ancient Chinese philosopher says, "The reason the enlightened prince and wise general conquer the enemy whenever they move...is foreknowledge."<sup>6</sup> This "foreknowledge" (intelligence) Sun Tzu refers to "cannot be elicited from spirits nor from gods, nor by analogy with past events, nor from calculations. It must be obtained from men who know the enemy situation."<sup>7</sup> The implication here is that any effective intelligence effort must include active human observation and reconnaissance.

In his treatise, *On War*, Carl von Clausewitz does not discuss reconnaissance directly but he does identify the value of intelligence as "the basis, in short, of our own plans and operations."<sup>8</sup> Yet even in his acknowledgement of the important role intelligence plays in planning, Clausewitz is cautious in placing too much reliance on it:

many intelligence reports in war are contradictory, even more are false, and most are uncertain....<sup>9</sup>

For Clausewitz, then, intelligence is a mixed blessing, a vital component of military operations that is at the same time a constant source of potential friction. But even Clausewitz' understandable frustration cannot mask a firm recognition that a clear and continuous intelligence picture contributes immensely to reducing uncertainty, facilitates better planning, and offers higher probabilities of success.

Henri Jomini seems somewhat more confident in the commander's ability to acquire vital information. In *The Art of War* he identifies four principal means of gathering information as espionage, reconnaissance, interrogation of prisoners, and "forming hypotheses of probabilities."<sup>10</sup>

Reconnaissance, according to Jomini, falls into two general categories. The first is terrain-oriented and is "entirely topographical and statistical, and the object is to gain a knowledge of the country, its

accidents of ground, its roads, bridges, etc...."<sup>11</sup> The other kind of reconnaissance is "ordered when it is necessary to gain information of the movement of the enemy."<sup>12</sup>

Perhaps the most applicable of Jomini's observations to this study is the one suggesting that a greater degree of certainty can be achieved "by multiplying the means of obtaining information; for no matter how how imperfect and contradictory they may be, the truth may often be sifted from them."<sup>13</sup>

From a more contemporary standpoint, Lieutenant Colonel Wayne M. Hall has formulated eight "principles of reconnaissance" which may help focus information gathering operations at all levels of command:

1. Information must be timely.
2. Reconnaissance operations must be aggressive.
3. Reconnaissance operations must be continuous.
4. Reconnaissance operations must focus combat power.
5. Information must be relevant.
6. The most effective reconnaissance operations are secret.
7. Reconnaissance operations must provide accurate information.
8. Reconnaissance operations must be complementary.<sup>14</sup>

Clearly, Colonel Hall's principles are built on a conceptual foundation laid by Sun Tzu, Clausewitz, and Jomini and represent an excellent summary of their ideas. As such, these principles provide a useful theoretical basis for this monograph and will act as a measure of the effectiveness of brigade reconnaissance.

### **III. HISTORICAL PERSPECTIVE**

The problem of providing for effective reconnaissance at the brigade level is not a new one for the US Army. In fact, there are significant historical trends indicating a continuing need for brigade tactical reconnaissance.

The Army's experience with brigade reconnaissance during World War II (WWII) is most clearly illustrated by the evolution of

reconnaissance forces within the armored division. As organized under Table of Organization (T/O) A in January 1942, the early WWII armored division employed the armored regiment as an intermediate brigade-type headquarters.<sup>15</sup> The three-battalion regiment had an abundance of reconnaissance elements including a 19-man intelligence and reconnaissance (I&R) platoon within the regimental headquarters company and a 22-man platoon in each of the tank battalions. Most importantly, the regiment itself had a separate 194-man reconnaissance company that worked directly for the regimental commander. All these reconnaissance units complemented the division's own reconnaissance battalion giving the armored division a comprehensive, redundant reconnaissance structure.

When the combat command was first introduced in the 1 March 1942 T/O 17, the concept of reconnaissance at all levels was modified. The combat command headquarters, like today's brigade, had no organic units, reconnaissance or otherwise. But since the armored regimental structure remained intact, task organized combat commands still had redundant reconnaissance until 1943.<sup>16</sup>

The most significant change in the WWII armored division occurred in September 1943. Under a revised T/O 17, the regiment, along with its organic reconnaissance company, was discarded leaving a standard division/combat command/battalion echelonment.<sup>17</sup> The armored and armored infantry battalions continued to operate with small 21-man reconnaissance platoons, while the division's reconnaissance battalion was strengthened into a 932-man cavalry reconnaissance squadron mounted in scout cars, half-tracks, and tanks. Combat experience in the European Theater of Operations showed repeatedly that the absence of dedicated reconnaissance at combat command level was inadequate. A number of divisions used task organization to address the reconnaissance "gap."

Most armored divisions fought their combat commands as semi-independent task forces and organized them accordingly. In the 4th Armored Division a combat command would typically consist of two tank battalions, an armored infantry battalion, "one troop from the

cavalry reconnaissance squadron, one or more armored field artillery battalions, an antiaircraft battery, a tank destroyer company, an engineer company, and combat command trains."<sup>18</sup> (see Appendix A)

The attachment of D Troop, 25th Cavalry Reconnaissance Squadron to Colonel Bruce Clarke's Combat Command A (CCA) provided the redundant reconnaissance capability that the T/O had failed to provide. During the encirclement of Nancy, D Troop remained with CCA obtaining vital information and providing security well forward of what we would describe today as a deep operation.<sup>19</sup>

Breaking up the division's cavalry was an expedient used to solve the combat command's reconnaissance problems. It was facilitated by a proliferation of pooled cavalry reconnaissance groups within the WWII corps which operated in concert with the divisions. Unfortunately, the abundant availability of reconnaissance forces near the end of the war obscured the real problem and established an assumption that the division would always provide the brigade-level commander with dedicated reconnaissance resources. Since WWII the Army's reconnaissance force structure has not contained the numbers or types of units to execute the kind of augmentation seen during the war. The reconnaissance lessons of WWII would become a stumbling block in the evolution of brigade reconnaissance in subsequent years.

In the post-war period, and certainly throughout the 1950s, the issue of organic brigade reconnaissance surfaced again as the Army faced a changing battlefield environment. An obsession with the nuclear battlefield increased the emphasis on speed, dispersion, and decentralization. The Reorganization of Combat Infantry Divisions (ROCID), or Pentomic, initiative resulted in the establishment of a 7-company battlegroup as the intermediate command echelon in the infantry division. Each of the division's five battlegroups had its own 33-man reconnaissance platoon. The battlegroup was normally reinforced with additional company-sized elements of tanks, engineer, artillery, armored personnel carriers, and, again, a troop from the division cavalry squadron.<sup>20</sup>

The armored division of the 1950s looked much like its WWII predecessor, perpetuating the proven combat command intermediate headquarters. It continued to lack its own reconnaissance until 1 December 1956 when the Reorganization of the Current Armored Division (ROCAD) TOE 17T added a scout section to the headquarters company.<sup>21</sup> This small unit (no officer, 15 soldiers) was lightly equipped and mounted in 1/4-ton trucks. The section's two squads were only capable of performing liaison, command post security, and limited reconnaissance for command post displacements. It lacked the size, organization, and equipment to conduct bona fide reconnaissance missions for the combat commander, but represented a positive step toward providing the commander with a dedicated reconnaissance element. This recognition ensured that the scout section was retained when the ROCAD TOE was finalized as TOE 17D in 1959.

The issue of organic brigade reconnaissance gained momentum in 1960 with the initiation of the Reorganization of Army Divisions-1965 (ROAD-65) study. ROAD ultimately led to the redesign of the existing infantry and armored divisions into a family of armored, infantry, and mechanized infantry (AIM) divisions under the E-series of TOEs.

At the outset the study proved to be a boon for proponents of a dedicated, fixed reconnaissance unit at the brigade level. With the redesignation of the combat command as a brigade came a proposed 144-man brigade reconnaissance troop (Appendix B). In a briefing to the commanding general of Continental Army Command (CONARC), Colonel George R. Sedberry explained the new organization this way:

The brigade is a tactical headquarters capable of controlling the combat operations of from 2 to 5 attached maneuver battalions. The brigade has, in addition to its headquarters and service company, an organic reconnaissance troop....This reconnaissance troop is identical to the ground reconnaissance troop in the division reconnaissance battalion.<sup>22</sup>

The platoons of the brigade reconnaissance troop were configured exactly like those of the maneuver battalion scout platoons and cavalry squadron providing the most comprehensive, complementary, and redundant reconnaissance structure since the early WWII armored division. The brigade reconnaissance troop was short-lived, however.

A series of coordinating conferences conducted in 1961 sought to keep the new AIM division's strength capped at 15,000 and the reconnaissance troop was eliminated in favor of the same brigade HHC scout section found in the previous D-series design. Part of the justification for eliminating the brigade reconnaissance troop was that battalion and division reconnaissance units would suffice to meet the brigade commander's specific information needs, the faulty lesson of the WWII combat command.<sup>23</sup> Unfortunately, the remaining scout section, like its D-series predecessor, had no officer, only 12 soldiers, was mounted in 1/4 ton trucks, and had little utility as a true reconnaissance unit.

In February 1962 the 1st Armored Division was reactivated at Fort Hood to conduct a series of validation exercises of the ROAD concept. One of the criticisms of the division's design noted in the commander's evaluation report was the limited capability of the brigade scout section. Major General Ralph E. Haines, Jr. reported that "an (armored cavalry) platoon should be added to the brigade headquarters company."<sup>24</sup> But because ROAD had also substituted an air cavalry troop in the divisional cavalry squadron for one of its four ground troops, neither the test results nor General Haines' comments affected the final design of the brigade. The expected increase in the divisional cavalry's capability, coupled with a continuing drive to reduce the division's manpower strength levels, led directly to the elimination of the scout section in the final 1963 E-series TOE.

As an aside, also emerging from the ROAD restructuring effort was the separate brigade.<sup>25</sup> The study recognized that contingencies may require the deployment and employment of combat forces smaller than divisions and, in fact, several separate non-divisional brigades



fought in Vietnam. Today's descendants of ROAD, the 194th Armored Brigade and 197th Infantry Brigade (Mechanized) are important elements of force projection contingency plans worldwide.

What is unique about the separate brigade and pertinent to this study is the brigade's organic armored cavalry troop. Dedicated to the brigade commander reconnaissance needs, the cavalry troop is organized and equipped identically to those of the armored cavalry regiment. The troop is part of a fixed brigade base that includes artillery, engineer, MI, signal, and CSS elements to which up to five maneuver battalions can be attached. The maneuver battalions bring their own scout platoons which complement the brigade troop's capabilities and provide reconnaissance redundancy.

Once again the issue of reconnaissance for the brigade became an area of interest when the Army looked at modifications to the AIM divisions after Vietnam. The Division Restructuring Study (DRS) was undertaken by TRADOC in 1978 to assist in the redesign of army divisions for the 1980s. As part of the brigade portion of the study the 2d Brigade, 1st Cavalry Division fielded a brigade scout platoon under a test TOE for exercises conducted between 8 September 1978 and 31 August 1979 at Fort Hood and on REFORGER 78.

The test scout platoon was small (only 1 officer and 14 soldiers) and was authorized in order to provide the brigade commander with limited reconnaissance and C2 assistance.<sup>26</sup> Consequently, the platoon was only used sparingly in traditional reconnaissance roles. But based on a positive REFORGER experience, the brigade commander's expectations for the platoon were expanded to include: escorting units through the brigade area; liaison with higher, lower, and adjacent units; conduct of route, zone, and area reconnaissance; conduct of rear area security; assisting in passage of lines, relief in place, and link-up operations; TOC security; and screening the brigade's front and flanks.<sup>27</sup>

The DRS study concluded that "a scout platoon at brigade is a viable concept" and recommended that the size be increased to 1 officer and

37 soldiers and that it be configured like the battalion scout and divisional cavalry platoons.<sup>28</sup>

The Army's next major restructuring effort was the Division 86 initiative which was later fielded as the J-series TOE. Largely as a result of the DRS study, Division 86 again incorporated a scout platoon at brigade level as part of the headquarters company (Appendix C). But before full fielding of the platoon could be achieved, the Army of Excellence study group recommended reductions in the entire J-series heavy division organizational structure which included eliminating the scout platoon altogether. The cut was explained this way:

The scout platoon was eliminated and the divisional military police company assumed responsibility, within the brigade area, for convoy escort, security, straggler control, and EPW missions. *The reconnaissance missions will be accomplished by the maneuver battalions and the division's cavalry squadron (emphasis added).*<sup>29</sup>

Unfortunately, AOE reduced the divisional cavalry's reconnaissance capability, too. The initiative reduced the squadron to two ground troops and one air troop making it even more difficult for the cavalry to support the division commander's information needs and even less likely that division assets would be capable of directly supporting today's maneuver brigades as they had in WWII.<sup>30</sup>

This historical review of brigade reconnaissance traces a number of significant trends. First, it is clear that the Army has recognized a continuing need for organic reconnaissance at the brigade level. It seems unlikely that the subject would constantly resurface the way it has if there wasn't a genuine need. Second, there are, in fact, precedents for having a dedicated brigade reconnaissance force of some kind. It has been repeatedly acknowledged that all commanders have a requirement for reconnaissance units immediately responsive to their needs and several study groups have tried to add brigade reconnaissance to the Army's force structure. Third, there appear to

be two primary reasons that an organic brigade reconnaissance element is absent from today's force structure. The first is the continuing assumption, owing to our WWII experience, that divisional cavalry and battalion scouts can adequately provide the brigade commander with reconnaissance support. The second reason seems to be a continuing unwillingness to accept the organizational costs associated with a redundant reconnaissance structure. Both reasons continue to block serious consideration of a brigade reconnaissance unit.

#### **IV. A SURVEY OF BRIGADE ORGANIZATIONAL AND OPERATIONAL DOCTRINE**

To fully appreciate the role reconnaissance plays at the brigade level, a thorough understanding of current Army organizational and operational doctrine is necessary.

According to Field Manual 71-3, *Armored and Mechanized Infantry Brigade*, the brigade is the major subordinate tactical maneuver command within the armored and mechanized infantry divisions.<sup>31</sup> The brigade serves as the cutting edge of AirLand Battle with a primary responsibility of executing the division's tactical plan by maneuvering firepower directly against the enemy.<sup>32</sup>

As a tactical command and control (C2) headquarters the brigade possesses no organic elements other than its own headquarters and headquarters company (HHC). To accomplish a specific mission the brigade is tailored by the division commander through the allocation of combat, combat support, and combat service support (CSS) components. A brigade headquarters is expected to command and control up to five armored or mechanized infantry maneuver battalions, though four is considered the optimum number.<sup>33</sup> These maneuver battalion "building blocks" can be further task organized into task forces to meet the brigade commander's tactical scheme.

In addition to the combat maneuver battalions, the heavy brigade receives other combat support and CSS assets from the division based

on mission requirements. Normally, these will include "slices" from units within the division base. On a habitual basis the brigade can expect support from divisional artillery, air defense, military police, engineer, IEW, and signal units as well as a logistical forward support battalion (FSB) from the division support command. Since this slice does not include dedicated reconnaissance support, the brigade must rely on the division for deep reconnaissance coverage and on its subordinate battalion task forces for close-in battlefield reconnaissance. Organized in this manner the brigade represents a formidable combat force.

Because the scope and nature of the combined arms and services represented within the brigade is all-encompassing, AirLand Battle doctrine considers the brigade to be the first echelon at which full synchronization of combat power occurs.<sup>34</sup>

Overall, the strength of brigade doctrine is that it provides for a flexibly and economically structured combat unit specifically tailored to accomplish a particular mission.

A fundamental assumption underlying the doctrine of flexible task organization is that pooled divisional assets attached down to the brigade commander will be as responsive to his needs as they are to their parent units. In his study of the role of the AOE heavy brigade in AirLand Battle, Major Robert W. Burkhardt suggests that this may be a weak assumption upon which to build a combat brigade:

Support units come with linkages to their own senior command and support organizations. These command and support links reduce the brigade commander's options for employing supporting units. Initiative in using supporting units is restricted by these command and support links... and AOE brigade design could possibly create inefficiency and confusion in combat.<sup>35</sup>

Doctrine calls for the brigade to fight as part of the division and rarely, if ever, to operate independently. The strength of this manner of employment is that divisional assets not directly supporting the

three maneuver brigades, such as aviation, rocket artillery, military intelligence units, and cavalry can be placed in general support allowing the division commander to retain an ability to influence the battle as he sees fit.<sup>36</sup> From a brigade perspective, however, overreliance on these general support resources is unwise. In an extensive examination of corps, division, and brigade force design, Major Raymond D. Barrett notes that "divisional units respond to the requirements of the division commander and are an unreliable source of assistance for the brigade commander."<sup>37</sup> This observation has profound implications for the brigade in the reconnaissance arena and will be explored in more detail in the next section.

The brigade, operating in support of the division commander's instructions and intent, conducts offensive and defensive operations. The brigade is considered the smallest unit capable of executing all five types of offensive operations: movement to contact, hasty attack, deliberate attack, exploitation, and pursuit.<sup>38</sup>

AirLand Battle doctrine presupposes that divisions and brigades will operate on a non-linear battlefield because of the increases in speed and dispersal characteristic of modern warfare.<sup>39</sup> Though our doctrine calls for the brigade to fight as part of the division, it seems clear that to meet these changing battlefield conditions a brigade must also be capable of self-sufficiency and semi-autonomous combat operations.<sup>40</sup>

Army doctrine, as expressed in Field Manual 71-3, also expects brigades to fight echeloned regiments which may outnumber friendly forces.<sup>41</sup> To accomplish what will likely be a difficult task, especially if the brigade must operate in a semi-independent mode, there are significant implications in how brigade reconnaissance is currently structured.

The relationship among the close, deep, and rear operations at the brigade level should be noted. The brigade's primary battlefield focus is to conduct close operations to defeat the enemy while protecting its combat support, CSS, and C2 facilities through rear operations.<sup>42</sup> While the division directs operations out to a distance of about 70 km,

brigades can direct battles up to 15 km beyond the forward line of own troops (FLOT) by controlling aviation and artillery operations.<sup>43</sup> The close and rear operation areas represent the brigade commander's primary area of operations and is the area for which his force is best organized. While the brigade is not fully capable of conducting true deep operations, the commander does have legitimate tactical concerns beyond the next hill which impact on his synchronization of the close and rear battles.

For the brigade commander "deep operations" are primarily limited to seeking out the second echelon battalions of the first echelon regiments of the Soviet division he is likely to face. While battalion task force commanders concentrate on the close, direct fire, line of sight battle the brigade commander locates those second echelon battalions so that direct and indirect fires can be subsequently massed. The need for sufficient surveillance and reconnaissance to assist the commander in synchronizing the brigade's fire and maneuver is critical.

Throughout, the brigade commander fights his force guided by the four tenets of AirLand Battle: agility, initiative, depth, and synchronization.

## **V. BRIGADE RECONNAISSANCE DOCTRINE**

Now that an organizational and operational framework for the brigade has been established, we can focus attention on how reconnaissance fits into the dynamics of brigade operations.

As we have seen thus far, at the brigade level the commander's success at focusing combat power is directly related to his ability to synchronize all arms and services. Acquisition of accurate combat information and intelligence is essential to this success.

Based on his mission analysis, the brigade commander articulates his information needs to the S2 who, in turn, is expected to develop priority intelligence requirements (PIR) and information requirements (IR) for the commander's approval. The intelligence officer translates

PIR and IR into specific intelligence, reconnaissance, and surveillance tasks that will be required of subordinate, attached, and supporting units. Requests for additional information are also forwarded to the division.<sup>44</sup>

Simultaneous with this process, the commander, S2, and S3 conduct a detailed intelligence preparation of the battlefield (IPB) to template the terrain in the area of operations and probable enemy formations and courses of action. The IPB process also identifies specific named areas of interest (NAI) and decision points which trigger the commander's synchronization of combat power. When coupled with PIR and IR requirements these NAIs and decision points become the basis for the brigade's reconnaissance and surveillance (R&S) plan which facilitates tasking elements of the brigade with specific collection missions.<sup>45</sup>

The actual collection of information on the enemy and terrain falls into the three categories of RSTA. The doctrinal reconnaissance planning process outlined above enables RSTA assets to be focused where they can do the most to gather the information needed to support the commander's intent. However, it is in this area, the physical collection of information, where gaps in responsiveness, organization, and coverage begin to develop.

Reconnaissance resources currently available to the brigade commander are the scout platoons of the subordinate battalion task forces and patrols constituted by the task forces. The scouts normally operate forward 5-10 km to assist the battalion commander in obtaining fine-grained combat information (exact enemy vehicle, weapon system, and fighting position locations) to fight the close battle. Additional deeper reconnaissance is supposed to be provided by the divisional cavalry squadron. Operating with ground and aerial units, the cavalry seeks coarse grained information on large 2d echelon division concentrations and movements which are a significant distance from the FLOT. Depending on the situation, the brigade commander needs more or less of both types of information to

synchronize his battle. This arrangement is summarized in the *III Corps Maneuver Booklet*

Division reconnaissance and intelligence operations support the brigade commander's PIR. Battalion scouts within the brigade play a part in intelligence collection but their principal missions are to perform specific reconnaissance tasks for the brigade and battalion commanders.<sup>46</sup>

The problem is that the brigade commander is dependent on the reconnaissance forces of commanders with different interests to fulfill his needs. While the brigade commander certainly does have the authority to employ subordinate task force scout platoons, there is obviously going to be a simultaneous degradation in the battalion's own reconnaissance capability when this occurs. The brigade commander cannot expect the same responsiveness from the division cavalry because, as Major Barrett points out,

The cavalry squadron...has neither the time nor the assets to support a reconnaissance mission requested by the brigade commander. Even if it did, the brigade would have to spend precious time appraising the cavalry commander of his situation and information requirements.<sup>47</sup>

In accordance with the theoretical constructs discussed in Section II, Field Manual 34-80, *Brigade and Battalion Intelligence and Electronic Warfare Operations*, emphasizes redundancy in reconnaissance operations. If we further accept the reconnaissance principle of complementarity, then the most effective way of executing our doctrine is by layering specially trained reconnaissance units. As long as the divisional cavalry is in position to supplement the close-in reconnaissance of the task force scouts, complementarity for the brigade exists. But when the fluidity and non-linearity of the AirLand Battlefield find the division cavalry squadron and maneuver



brigades operating apart from one another, redundancy falters. Without an intermediate reconnaissance force "that neither strips a battalion of the same essential resource nor becomes a 'do as much as you can' mission for an already overextended cavalry squadron," the brigade commander will find himself virtually blind.<sup>48</sup>

Our doctrine pertaining to the brigade emphasizes redundant and complementary reconnaissance operations in and is fundamentally sound. It is our reconnaissance force design which impedes adequate execution.

Jomini emphasized multiplicity of intelligence collection means. For the heavy brigade multiplicity is achieved by supplementing a limited reconnaissance capability with surveillance and target acquisition resources. Electronic surveillance tasks are generally accomplished by the supporting IEW company team slice the brigade receives from the division's military intelligence battalion. Depending on the tactical situation and mission, the IEW company team could include ground surveillance radars (GSR), radio direction finders (DF), communications jammers (COMJAM), enemy prisoner of war (EPW) interrogators, communications interceptors, and counterintelligence (CI) teams. The electronic systems the company team possesses are extremely accurate and can provide surveillance out to the distances required by the brigade commander. Interface between these IEW resources and the brigade staff is provided by an IEW staff element (IEWSE) located in the brigade tactical operations center (TOC).<sup>49</sup>

While it appears that the brigade is well supported by IEW assets, there are some important limitations on their responsiveness to the brigade commander's information needs. First, the majority of MI resources in each IEW company team are held in general support of the division and only operate in the brigade sector to complement other divisional MI assets. Most EW direction finders and communications interceptors must work in concert with others outside brigade area to be most effective. Second, because the brigade lacks an adequate analysis capability, the bulk of the electronic collection effort must be routed through the technical control and analysis

element (TCAE) at the MI battalion's TOC. Third, special augmentation is required to provide EPW interrogators and CI teams and the information they acquire is likely to be sketchy at best and probably will not be of immediate value to a brigade commander. And finally, electronic surveillance means are susceptible to weather and terrain interference, deception, maintenance failures, and human misinterpretation.

The IEWSE may be the most valuable MI asset to the brigade commander. It is a key member of the brigade RSTA system that works as the middleman providing immediate combat information to the commander by monitoring the activities of MI assets operating in the brigade area whether they are directly supporting that brigade or not.

So, while MI IEW resources can and should complement the brigade's reconnaissance effort, they cannot be expected to substitute for it. More and more these IEW assets are expected to fill in the "gap" left by the absence of a brigade reconnaissance element, yet there are profound organizational, procedural, and technical shortcomings which limit their responsiveness to the brigade commander's specific needs.

Target acquisition is the third element of the brigade's intelligence battlefield operating system. Target acquisition tasks are routinely conducted for the brigade by divisional artillery and air defense elements supporting the brigade with additional input from reconnaissance and surveillance assets. Weapons locating radars and forward area alerting radars (FAAR) are excellent tools for focusing the brigade's fire support combat power.

These systems, however, operate directly for the brigade's fire support commanders and only indirectly for the brigade commander. As information gatherers, firefinding radars provide good long-range (up to 50 km) coverage which, when integrated with IEW surveillance and ground reconnaissance, can give a more complete picture of the enemy situation.

Like the technological means employed by the IEW company team, target acquisition radars also have technical limitations. And since they are not positioned and controlled by the brigade commander, they can only be expected to provide incidental combat information.

Depending on the situation, our doctrine states that the brigade commander could also receive information from a variety of other means such as US Air Force liaison officers, Army aviation, and engineers. But again, the timeliness, applicability, and responsiveness of these resources fluctuates.

Overall, our doctrine provides the brigade with no systematic and sound way to plan information gathering missions. Our doctrine also indicates that there is a wide variety of RSTA resources available to the commander to satisfy his information needs. After closer examination, however, serious shortcomings emerge.

First, the brigade is almost totally reliant on the division to provide essential collection means, resources which may or may not be allocated to a particular brigade. Second, when divisional assets are allocated, they often arrive at the brigade with significant limitations or restrictive linkages. Third, the bulk of the brigade's supporting surveillance and target acquisition elements are electronically based which provide little to no information on terrain and require the enemy's "cooperation" in the form of active emissions. And finally, because it lacks its own reconnaissance element, the brigade is not sufficiently organized to conduct the redundant reconnaissance our doctrine calls for. It appears that instead of developing a comprehensive reconnaissance structure to support RSTA, we have tried to replace reconnaissance with technological collection means.

Reconnaissance at the brigade level is not just a US Army issue, it is an international one. Our allies and adversaries consider reconnaissance an important combat multiplier, so it is beneficial for us to at least consider how other armies organize their tactical reconnaissance units to support the brigade-level commander.

## **VI. BRIGADE-LEVEL RECONNAISSANCE FORCES OF FOREIGN ARMIES**

The value of structuring organic reconnaissance forces to support the brigade or equivalent commander seems to be given a higher priority in foreign armies for two reasons. First, the Soviets and our NATO allies each approach the concept of reconnaissance somewhat differently than does the US. There is, however, commonality in their respective doctrines which demonstrates an understanding that commanders at all levels need reconnaissance elements at their immediate disposal. Second, these armies organize and equip their reconnaissance units to support their own approaches. This section will compare and contrast the brigade-equivalent reconnaissance forces of the Soviet, West German, British, Canadian, and French armies with the US model. From this we can determine if the US approach is synchronized with internationally accepted norms regarding brigade reconnaissance.

The Soviets have a fundamentally different philosophy toward reconnaissance at the tactical level and structure the reconnaissance forces of the division to execute their doctrine accordingly. David Isby writes that

unlike their western counterparts, Soviet reconnaissance units are purely for scouting. They do not have a screening and security mission. NATO reconnaissance units tend to follow late World War II patterns: strong, often combined-arms forces, able to fight on their own for information. This is a completely different concept from Soviet tactics, which are reflected in their reconnaissance vehicles: light and mobile, designed to cover the long distances of their far ranging patrols and to depend on speed and concealment for protection.<sup>50</sup>

Like the US Army, the Soviets conduct troop (tactical combat) reconnaissance to obtain information for divisional, regimental, and battalion commanders about the terrain and enemy in areas of the battlefield which they can directly influence. But, Isby's comments indicate that in terms of LTC Hall's model, the Soviets place greater emphasis on stealth and secrecy in their approach to low-level combat reconnaissance operations. This is in contrast to a US doctrine which has traditionally emphasized the necessity of "fighting for information."

The Soviet concept is apparently more focused on reconnaissance penetration of enemy lines, survival, and reporting. In their view, patrols that become involved in active combat or security operations quickly lose their information gathering value.<sup>51</sup> When and if extra security for the main body is required, the regular combat units themselves are tasked to execute screens, often in conjunction with the reconnaissance elements. Further, compared with the US RSTA model, the Soviet depend less on electronic sensors and more on direct visual ground reconnaissance. To perform troop reconnaissance, divisional and regimental commanders employ specially trained units.<sup>52</sup>

The Soviet motorized rifle or tank division's 373-man reconnaissance battalion is multi-functional with each of its five reconnaissance companies organized to accomplish specific tasks. It consists of a light reconnaissance company, two heavy reconnaissance companies, a radio/radar reconnaissance company, and a long-range reconnaissance company. Patrols from these companies will normally operate up to a day's march (35-50 km) forward of and across the division's line of march. Engineer and NBC reconnaissance troops from the divisional engineer and chemical defense battalions will routinely accompany these patrols mounted in specially-designed BRDM wheeled scout vehicles.<sup>53</sup> The long-range reconnaissance company can operate as far out as 250 km. Unlike the US divisional cavalry squadron, the battalion has no organic aviation resources.

The US brigade's opposite number, the motorized rifle or tank regiment, also has a capable reconnaissance organization dedicated to the commander. The regimental reconnaissance company is small by US standards with 4-5 officers and 43-57 soldiers equipped with three BMPs, four BRDMs, and 5 motorcycles and organized into two platoons and a motorcycle section. The company operates about one-half day's march ahead of the regiment's main body to provide the commander early warning and reaction time.<sup>54</sup>

When added to the five companies of the divisional battalion, the regimental reconnaissance companies give the Soviet division commander a 9:1 advantage over his US opponent, in the number of company-size reconnaissance units he can employ. This disparity in capability is exacerbated when the reconnaissance capabilities of Soviet motorized rifle and tank battalions are included.

Motorized rifle and tank battalions are not given dedicated scout or reconnaissance units, but the fact that the specialized reconnaissance structure ends at the regiment does not mean that Soviet battalion commanders are without a substantial reconnaissance capability. On the contrary, Soviet doctrine and practice call for these units to constitute combat reconnaissance patrols (CRP) from within.<sup>55</sup>

Normally, a battalion will form a platoon-sized CRP which is sent out to act as a point detachment primarily to gain and maintain contact with enemy units previously located by divisional and regimental reconnaissance elements. It is common practice in all Soviet units to utilize regular troops this way to reinforce or augment the operations of the specialized reconnaissance troops.

This multi-echelon approach characterized by stealthy reconnaissance techniques gives the Soviets a system of continuous, complementary coverage throughout the battle area. All commanders, including the brigade-equivalent regimental commander, have tactical reconnaissance capabilities immediately responsive to their information needs. Their system is clearly redundant and emphasizes reconnaissance over combat. Recognizing that "intelligence is reconnaissance and reconnaissance is intelligence" enables Soviet

commanders to focus combat power by keying on essential elements of information gained by a methodical philosophy of reconnaissance.

Though the Federal Republic of Germany's *Bundeswehr* is nominally organized into heavy-type divisions, the army's 36 combat brigades remain the essential building blocks and primary maneuver forces.<sup>56</sup> Unlike its American counterpart, the German tank (*panzer*) or mechanized infantry (*panzergrenadier*) brigade has a fixed combined arms design like the Soviet motorized rifle or tank regiment. The subordinate infantry and armor battalions will most often fight "pure." The only true tailoring or task organizing is accomplished by combining brigades under a division headquarters. This distinction not only reflects a difference in tactical philosophy but also in reconnaissance philosophy.

The central position held by the brigade echelon in the *Bundeswehr* helps explain why the Germans have built a sizable reconnaissance platoon there and, like the Soviets, have left the scout-type platoon out of the maneuver battalions themselves. This platoon is a 50-man unit consisting of six troops (sections) of two *Luchs* wheeled armored cars each.<sup>57</sup> The platoon works directly for the brigade commander using the principle of secrecy and stealth as its guiding tactic.

The Germans also have a heavy 515-man armored reconnaissance/surveillance regiment (battalion) at division level for longer range information gathering. This unit is equipped with 31 Leopard main battle tanks and 31 *Luchs* indicating a much greater combat role (i.e., economy of force and security) than the brigade reconnaissance platoon.

At the battalion level the Germans feel the type of information required by the commander to employ his direct-fire weapon systems does not require specially trained reconnaissance personnel. Close-in reconnaissance for the *panzer* and *panzergrenadier* battalions, therefore, comes from patrols sent out by the subordinate companies, the same tactic used by Soviet battalion commanders.

German doctrine and force structure supports a tactical philosophy which recognizes that brigades will often conduct operations as semi-independent task forces under general division control. In this operational scheme, the brigade is the primary synchronizing headquarters. Therefore, the brigade commander is provided the necessary reconnaissance tools to gather the information he requires to make decisions which contribute to the overall synchronization of combat power.

As in the Soviet model, the German reconnaissance structure possesses an inherent redundancy by eliminating gaps at the crucial brigade echelon of command. The fact that neither the Soviets nor the Germans have specialized battalion scout platoons does not appear to impede battalion operations since close-in tactical reconnaissance is routinely accomplished by small unit patrols.

In January 1981, the British Army restored the badly missed brigade level of command within its armored and infantry divisions. Before then the division commander had a very broad and inefficient span of control over a large number of mechanized infantry battalions and armored regiments (battalions). Yet even with this welcome change in command echelons, the regimental system still drives British organizational design and influences the reconnaissance force structure within the division.

The brigades of an armored division, usually organized with triangular mix of tank regiments and mechanized infantry battalions, will not normally have a dedicated reconnaissance element. Instead, as in the US brigade, the battalions have their own reconnaissance platoons of eight *Scimitar* or *Scorpion* light tracked scout vehicles.<sup>58</sup>

Within the infantry divisions, however, the reconnaissance structure is somewhat more comprehensive. Brigades each have an organic reconnaissance regiment (battalion) equipped with *Fox*, *Saracen*, and *Ferret* wheeled scout cars which doubles as the brigade's armor battalion. The infantry battalions also have wheeled vehicle-mounted scout platoons.



Unlike the US model, the division lacks an organic reconnaissance unit itself and relies either on subordinate units or corps-level reconnaissance regiments for its reconnaissance needs.

Clearly, the British reconnaissance structure is somewhat fragmented. As mentioned, this is largely attributable to the regimental system which cannot account for units smaller than battalion size. In other words, at the brigade level, where a reconnaissance platoon or company would be appropriate, as in the Soviet and German examples, the regimental system either provides no element (as in the armored division) or a battalion (as in the infantry division). The result is a lack of reconnaissance redundancy and complementarity throughout the forces.

Canadian brigades, like West German formations, are organized under the "brigade base" concept and in many ways resemble the US separate armored or mechanized infantry brigade.<sup>59</sup> The standard brigade will normally consist of a fixed combination of maneuver battalions, engineer battalion, service battalion, medical ambulance company, and artillery battalion and be commanded by a brigadier general.

The Canadians, like the US, will routinely cross-attach companies from the maneuver battalions to form task forces called battle groups. Similarly, company teams are formed by further exchanging platoons within the tank and mechanized infantry companies.

Reconnaissance elements are organic at both the brigade and maneuver battalion echelons. In the case of the 4th Canadian Mechanized Brigade Group (CMBG) in Europe, one squadron (company) of the Royal Canadian Dragoons (tank battalion) is organized and equipped to perform reconnaissance specifically for the brigade group commander. The squadron can operate as far out as 10-15 km forward of the brigade main body mounted in its 18 *Lynx* tracked armored reconnaissance vehicles. Because of their light weight and limited firepower, *Lynx* -mounted reconnaissance units carry out active ground reconnaissance principally by stealth.

Unlike the British example, by structuring one company-size reconnaissance force within the tank regiment, the Canadians appear to have solved the brigade reconnaissance problem within the constraints of the regimental system. To provide reconnaissance redundancy, the 2 mechanized infantry battalions each have their own scout platoons also outfitted with 9 *Lynxes*. The reconnaissance structure of the homebased brigades of Mobile Command is identical to that of the 4th CMBG.<sup>60</sup>

The Canadians are currently fielding the 1st Division in Germany which will combine the 4th CMBG and the recently repositioned Canadian Air Sea Transportable (CAST) Brigade Group under one headquarters. Included in the restructuring effort is a divisional reconnaissance regiment (battalion) which will complement the brigade and battalion reconnaissance units, resulting in a completely redundant reconnaissance structure.<sup>61</sup>

The French armored division is small by US standards with a strength of only 7,000. Its structure, with 2 mechanized infantry battalions, 1 motorized infantry battalion (wheeled APCs), 2 armored regiments (battalions), and assorted combat support and CSS units subordinated directly to the division, give it the appearance of a reinforced brigade.<sup>62</sup>

The French adhere to the concept of reconnaissance for all commanders and in doing so provide organic reconnaissance at both division and regimental levels. The division has an organic reconnaissance troop (company) consisting of 4 platoons: 3 reconnaissance platoons and 1 radar surveillance platoon. At the regimental level, all three types of maneuver units have organic scout platoons.

The French have always been great proponents of reconnaissance and have been the world's foremost producer of armored cars since WWII. The French prefer to equip their reconnaissance units above the division level with heavier armored reconnaissance vehicles in order to accomplish various economy of force and security missions. The reconnaissance units within the armored division described above

are much more lightly equipped. The division reconnaissance troop and regimental scout platoons are mounted in lightly armed 1/4 ton trucks. Consequently, these elements must operate on the principle of secrecy and stealth and often conduct their reconnaissance and surveillance missions by emplacing discrete observation posts.

In summary, this section has shown that two international norms regarding reconnaissance exist. The first is that foreign armies tend to emphasize organic ground reconnaissance for commanders at all echelons. With the possible exception of the brigades of the British armored division, the force structures of all five nations described include reconnaissance capabilities at divisional, brigade/regimental, and battalion/regimental levels that do not require respective commanders to rely on the reconnaissance units of others to gather vital information. It also seems evident from this cursory examination that a higher degree of redundancy is achieved in these armies by providing the brigade-equivalent commander with his own reconnaissance unit that complements the assets of higher and lower commanders. It should be noted that even though the NATO allies possess similar technological surveillance and target acquisition means as the US, they continue to place great credence in the value of ground reconnaissance as a complementary means of information gathering. At the same time the Soviet model is particularly comprehensive and points up the weaknesses inherent in our own brigade reconnaissance structure.

The second international norm which emerges from this section, David Isby's comments notwithstanding, is that the principle of stealth and secrecy in tactical reconnaissance is becoming more important in all armies.

There has been, in recent years, a noticeable shift in the US Army's reconnaissance philosophy. Greater emphasis is being given to the principle of stealth. However, organizational issues remain and a number of initiatives have been undertaken to improve the brigade's reconnaissance effort and, by extension, the overall RSTA system within the brigade.

## **VII. CONTEMPORARY STUDIES, INITIATIVES, AND FIELD EXPEDIENTS**

As mentioned at the outset, NTC experience, field exercises, and other studies in the last few years have exposed serious deficiencies in the reconnaissance operations of the heavy brigade. A wide variety of measures have been undertaken within TRADOC and operational units to develop solutions to the problem of brigade reconnaissance. The initiative which may hold the most promise is the ongoing General Officer Executive Council on reconnaissance and counterreconnaissance. Chartered by the TRADOC commander, the GOEC has made a sincere effort thus far to identify organizational and operational shortcomings throughout the Army's entire reconnaissance structure. Though it is gratifying to see that brigade reconnaissance is a major focus of the group, it remains to be seen if the council sidesteps the organizational issues and perpetuates the increasingly dubious assumption that divisional cavalry and other technological collection means alone are sufficient and responsive to meet the brigade commander's needs on the AirLand Battlefield.

This section will concentrate on four other attempts to identify and solve the problems created by the absence of a viable reconnaissance element at brigade level. They are the 1986 Center for Army Lessons Learned (CALL) Priority Issue survey, the Armor School's proposals for a brigade reconnaissance unit, the proposal to employ remotely piloted vehicles (RPV) to support the brigade reconnaissance effort, and finally, the expedient measures taken by field commanders themselves to deal with their reconnaissance problem. The intent is to determine if these measures point in a direction consistent with the perspectives outlined thus far.

The CALL established brigade tactical reconnaissance as a priority issue in November 1986 and conducted an extensive Army-wide survey of schools, centers, and operational units to solicit suggestions on how to improve the brigade reconnaissance system. The survey

was productive and indicated a general dissatisfaction with the intelligence and combat information support currently available to the brigade commander.

Among the clearest responses advocating an organic brigade reconnaissance unit was from then-Brigadier General H.G. Taylor, Commander of the NTC who stated

The increasing participation of brigade headquarters in our battalion task force rotations clearly indicates a need for a brigade reconnaissance element. If brigade is the level where synchronization of all elements of combat power is to occur (as AirLand Battle doctrine indicates), then it certainly follows that an organic intelligence collection asset is needed.<sup>63</sup>

His reply also indicated that

The brigade commander could certainly enhance his intelligence collection effort if he had an organic asset which could cover brigade NAIs that cannot be covered by division or subordinate unit assets....The division can provide some near real time intelligence information to the brigade; however, in most cases, division assets will be looking deep and cannot adequately cover all of the brigade's NAIs.<sup>64</sup>

The NTC commander's response concluded by encouraging the development of a reconnaissance force, not another fighting force, for the brigade.

Field commands like the 24th Infantry Division (Mechanized) echoed the NTC's concerns and suggestions stating that the division slice of IEW assets contains "no ground reconnaissance to assist or augment the scout platoons. There is no ability to see 'over the next hill'..."<sup>65</sup>

The III Corps response emphasized that the brigade reconnaissance problem is no longer just a doctrinal or training issue either:

Doctrinally the Army's intelligence policy has been to provide the commander with collection systems necessary to cover his area of influence (generally felt to be out to the lethal ranges of organic weapons)...but this doctrinal approach breaks down at maneuver battalion and brigade levels because the Army has not resourced the brigade with the systems to cover the brigade's area of influence...."66

Further, the corps rejected the notion that better management of existing assets is the answer or that fine-tuning division assets to be more responsive to the brigade will solve the problem:

These may have been attainable goals in the pre-AirLand Battle era, but modern battle-field dynamics argue for a fresh approach.<sup>67</sup>

In short, field commanders agree that the brigade commander needs an organic reconnaissance element. However, those responsible for the doctrine that ultimately drives organizational changes, as well as force developers themselves, are reluctant to view the problem in organizational terms.

In spite of the inadequacies discussed in section IV, doctrine writers at Fort Leavenworth contend that brigade commanders have not fully exercised their existing RSTA systems. The problem, in their view, is that the information needed by the brigade commander is available, it's just not getting to him in a timely manner. They balk at acknowledging the need for an organic reconnaissance unit, suggesting that

If a brigade level reconnaissance element is deployed in addition to the battalion scout platoons, it appears that we would be giving

the brigade a mission now performed by the divisional cavalry squadron.<sup>68</sup>

Similarly, the Army's force developers continue to view technological means as the solution to the problem, insisting that

There are probably enough intelligence collection assets available for the brigade, if integrated into the brigade's thinking, (already) at the brigade level....The hard, and real, answer is the brigade is not going to get organic assets....<sup>69</sup>

The real issue from these responses is clear. Field commanders charged with executing AirLand Battle doctrine say they need organic reconnaissance at brigade level but new organizations, no matter how vital they are to mission accomplishment, are expensive to field. Therefore, those charged with developing forces prefer to fall back on the same assumptions that have plagued the brigade reconnaissance issue for 40 years.

In 1987 the Armor School proposed the formation of a brigade reconnaissance element. Part of its criteria for development included security missions in addition to traditional reconnaissance activities:

A brigade reconnaissance element should provide extended reconnaissance and security for the brigade commander and is required to operate on a scale created by the size of the brigade sector.<sup>70</sup>

To cover the required area and execute both reconnaissance and security missions, the Armor School concluded that the appropriate organization would be a company. This concept seemed consistent with the historical examples outlined in Section V and the international norms examined in Section VI. However, bowing to fiscal constraints, the original proposal was scaled back to a 38-man platoon equipped with four M-3 Cavalry Fighting Vehicles (CFV), six High Mobility Multipurpose Wheeled Vehicles (HMMWV), and four

motorcycles. Whether this platoon can still meet the original criteria of conducting reconnaissance *and* security for a brigade is dubious. Perhaps a platoon would be sufficient to meet the brigade commander's reconnaissance needs if there were less emphasis on the security aspect (a combat mission) and more on the principle of reconnaissance by stealth and secrecy.

In recent years the Army has looked to the development of RPVs as another battlefield information gathering tool. This as yet unfielded asset has been offered as a solution to the brigade reconnaissance problem.<sup>71</sup> If employed as a complement to ground reconnaissance instead of as a substitute, RPVs could help improve the redundancy of the brigade's RSTA system. But as a technologically-based collection system, RPVs are subject to many of the same limitations previously noted with other IEW systems.

Command and control is also a potential problem. If organic to the brigade, responsiveness will be good, but will require additional analysis overhead in the brigade headquarters. If RPVs are controlled solely at division (as currently planned), support to the brigade will be subject to the linkage problems associated with the other components of the existing brigade slice.

In short, RPVs are a possible supplementary solution to the brigade commander's problem, but not a cure-all.

Some brigade commanders, recognizing the need for a more responsive reconnaissance system, have come up with a variety of ad hoc units, SOPs, and drills to close the reconnaissance "gap" between battalion and division.

Among the means employed are "scrambling" drills in which the battalion scout platoons are assembled into a makeshift company to provide the brigade commander with an "organic" reconnaissance force. Clearly, this procedure cannot be used for extended periods because there is no accompanying headquarters element to provide command and control, logistical, and administrative support. It also strips the battalion task force commanders of the "eyes and ears," though they can still field reconnaissance patrols internally. The



effectiveness of such drills is hampered when the task organization of maneuver battalions is changed by division.

Another approach is to employ the scout platoon of the reserve task force under brigade control. Command and control is simpler since the brigade S2 normally controls reconnaissance assets while under brigade control. The major disadvantages are the limitation of a platoon to conduct reconnaissance and security for a brigade area of operations, linkages to the parent battalion task force, and the risk of the task force permanently losing its reconnaissance capability.

A third, and somewhat novel, approach was used by a commander in the 4th Infantry Division (Mechanized) during a recent NTC rotation. The unit formed a small "brigade observation team" to establish outposts to observe critical NAIs and decision points. The team was controlled by an officer detached from the brigade S3 section and reported directly to the S2.<sup>72</sup> The success achieved by this team was attributed to an emphasis on stealth, secrecy, and avoidance of enemy contact. The brigade commander concluded that at his level, a small team equipped with adequate communications was more vital than a heavier force capable of both reconnaissance and security.<sup>73</sup>

Brigade commanders have tried and are trying innovative ways to overcome their reconnaissance shortfall by employing internal assets (normally battalion scout platoons). Each method, though effective for short periods, seems to "rob Peter to pay Paul." They do, however, offer one interesting insight. If the brigade commander requires reconnaissance and security, then a larger, more robust organization of company size is probably required. A platoon is simply not structured to do both for a heavy division on the extended AirLand Battlefield. But when the commander concentrates his effort on scouting, reconnaissance, and clandestine surveillance, a smaller, lighter element is fully capable of accomplishing the information gathering mission.

There is, therefore, general agreement throughout the Army that the existing brigade reconnaissance system is not responsive to the commander. However, there is a fundamental split in terms of

suggested solutions. There is one school that fosters the status quo. That is, the brigade commander can be adequately supported in information gathering by divisional assets and increased technology. The other school suggests that the present reconnaissance organization needs to be reconfigured to provide a dedicated, organic reconnaissance force for the brigade commander's use. The first school continues to rely on assumptions that are not reflective of the way the brigade is likely to fight on the AirLand Battlefield. The second school acknowledges changes in battlefield dynamics which will require the brigade commander to be more reconnaissance self-sufficient than ever before.

### VIII. CONCLUSIONS AND RECOMMENDATIONS

This monograph has shown that the fluid, non-linear characteristics of the AirLand Battlefield will require the brigade commander to synchronize his combat power in increasingly semi-independent operations. Timely intelligence and combat information are crucial to decisionmaking and synchronization. But while we now ask more of the brigade commander than ever before, the Army has not provided him with the kinds of tools necessary to execute its doctrine.

The existing RSTA system charged with acquiring the commander's vital information needs as expressed in his PIR lacks the redundancy Jomini spoke of. This lack of redundancy takes two forms. The first is not having a reconnaissance element to complement the reconnaissance units at division and battalion level. The second is not having a responsive and dedicated ground reconnaissance force to complement other electronically-based RSTA resources.

What's required, in a conceptual sense, is the ability to "layer" the reconnaissance forces of all command echelons throughout the battlefield in a manner that enables each commander to direct his own information gathering while simultaneously taking advantage of the collection efforts of the echelons above and below. Whether on

offense or defense, this concept of complementarity would facilitate an orderly reconnaissance handover from division cavalry to brigade reconnaissance to battalion scouts and provide an increasingly fine-tuned intelligence picture from top to bottom. It would also provide the degree of flexibility necessary in semi-independent operations by giving each commander his own "eyes" when the mission carries the unit beyond the collection capabilities of the other echelons. Unfortunately, under today's force structure the brigade cannot contribute to such a concept.

History has shown that this concept is indeed valid. The success achieved by Colonel Bruce Clarke's CCA when called upon to conduct semi-independent operations was due in part to having a dedicated reconnaissance element that responded directly to his information needs. At the same time Colonel Clarke could rely on other divisional and non-divisional assets for longer range information. The subordinate battalion commanders, in turn, benefitted from having their own scouts in addition to the information collected by CCA and division.

Today, our allies as well as our adversaries recognize the need for dedicated reconnaissance for all commanders and the redundancy achieved by this concept. As we have seen, most armies place a great deal of emphasis on the brigade echelon in their operational doctrines and give the commander the necessary reconnaissance tools to act as part of a larger force or, if required, in a more autonomous mode. As to actual execution, the principle of secrecy and stealth in reconnaissance appears generally accepted and is best exemplified by the Soviet model, the effectiveness of which has been repeatedly demonstrated by the Opposing Force at the NTC.

The fundamental conclusion of this monograph, then, is that the brigade reconnaissance issue is primarily an organizational one. The brigade commander needs his own organic reconnaissance unit in order to have a fully integrated information gathering system capable of supporting his decisionmaking and synchronization efforts.

To rectify the situation, the Army needs to develop and field a reconnaissance company in each heavy brigade, along the lines of the original ROAD proposal or the heavy separate brigade's organic armored cavalry troop, but lighter in design. A proposed organization for the brigade reconnaissance company is shown at Appendix D.

Separate from the existing brigade headquarters company, the brigade reconnaissance company would complement the battalion scout platoons and the divisional cavalry squadron. When employed in a "layered" manner between the division's cavalry's long-range area of interest (20-70 km out) and the battalion's close-in reconnaissance of the direct-fire engagement area (5-10 km out), the brigade reconnaissance company would restore the redundancy that is currently lacking and help achieve the conceptual goals outlined above. Commanded by a captain, the company would be a command and control headquarters for brigade reconnaissance operations.

By equipping its three platoons with five HMMWVs each it would be capable of both extended reconnaissance (10-20 km beyond the FLOT) and limited screening operations. Naturally, a reconnaissance company configured this way must concentrate on infiltration, stealth, and observation for survivability and mission accomplishment. It would be ideally suited to terrain reconnaissance and NAI/decision point surveillance. Clearly, it would not be expected to "fight for information" without augmentation. To be most effective, however, the company must have the necessary training and specialized optical, night vision, and communications equipment to operate out to a distance of 20 km beyond the battalion task force scouts.

Since the proposed company is light and relatively austere (no M-3 Cavalry Fighting Vehicles, for instance), its sustainability requirements would be far less than for a heavier unit. Having its own headquarters and maintenance elements means it could be logistically and administratively self-sufficient for short periods.

Finally, the company would be an excellent resource for the brigade commander in other aspects of command and control such as

**liaison, limited rear area security, escorting units through the brigade area, emplacing sensors, etc.**

**The relative benefits of such an information gathering unit to the brigade clearly outweigh the costs and must be seriously considered if we are to overcome our problems with tactical reconnaissance at the brigade level.**

**Appendix A: Task Organization, Combat Command A,  
with D Troop, 25th Cavalry Reconnaissance  
Squadron Attached, 28 August 1944.**

Source: Gabel, *The 4th Armored Division Encirclement of Nancy*

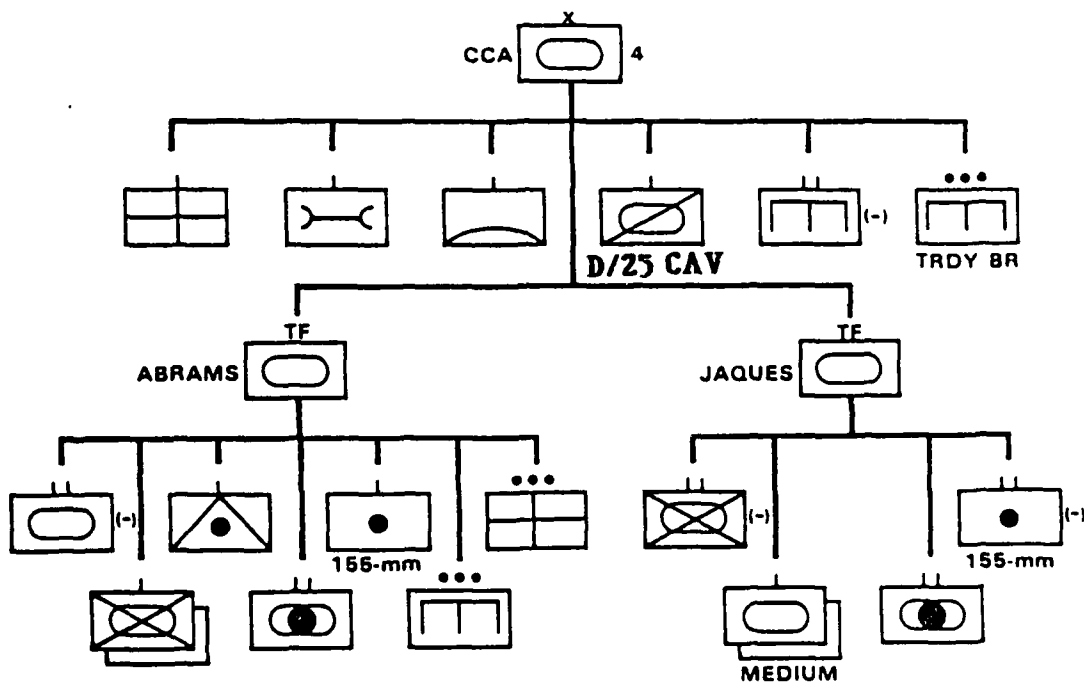

**Appendix B: Proposed ROAD Division with Brigade  
Reconnaissance Company**

**Source: Briefing for General Herbert B. Powell, CG, CONARC,  
23 December 1960**

**DIVISION BASE COMMON TO ALL DIVISIONS**

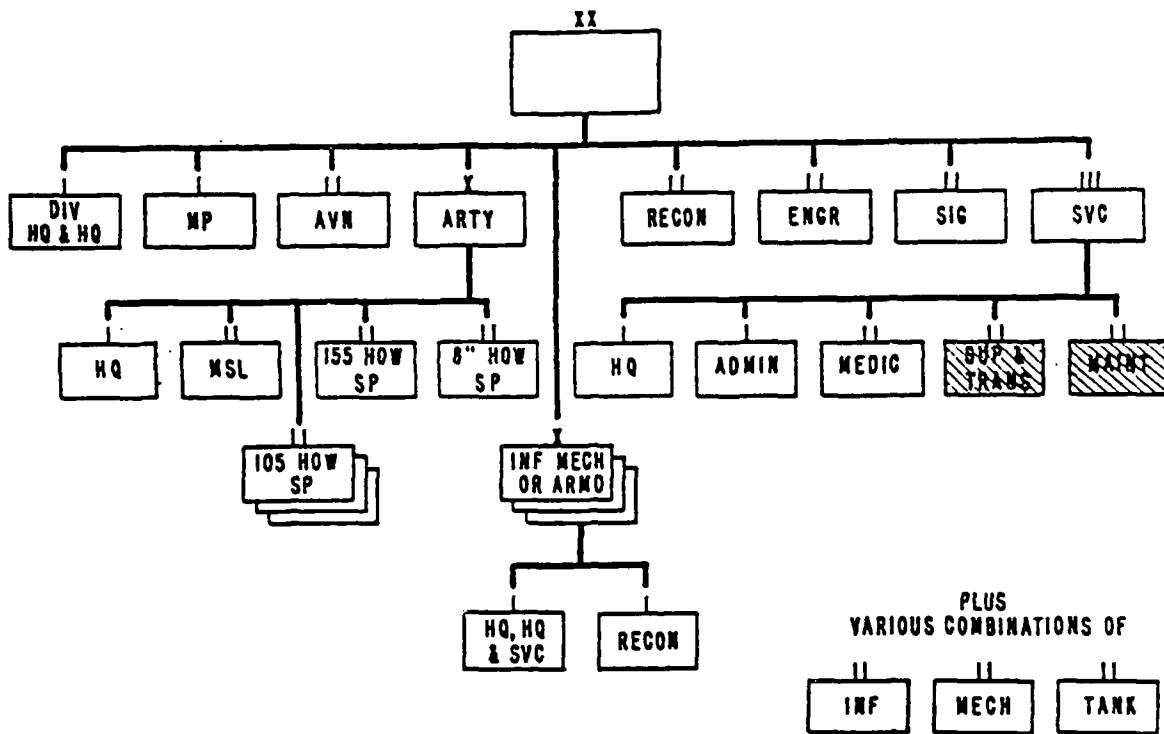

# Appendix C: Division 86 Brigade HHC with Organic Scout Platoon

Source: Army of Excellence Final Report

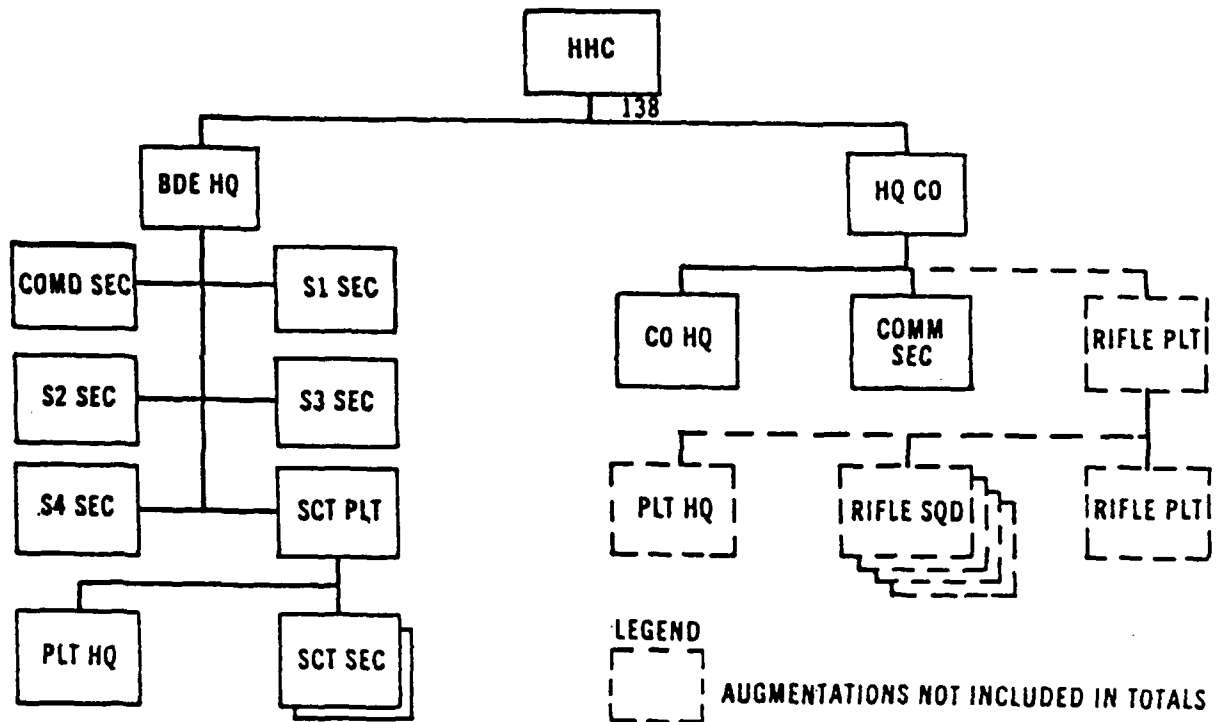



Appendix D: Proposed Brigade Reconnaissance Company

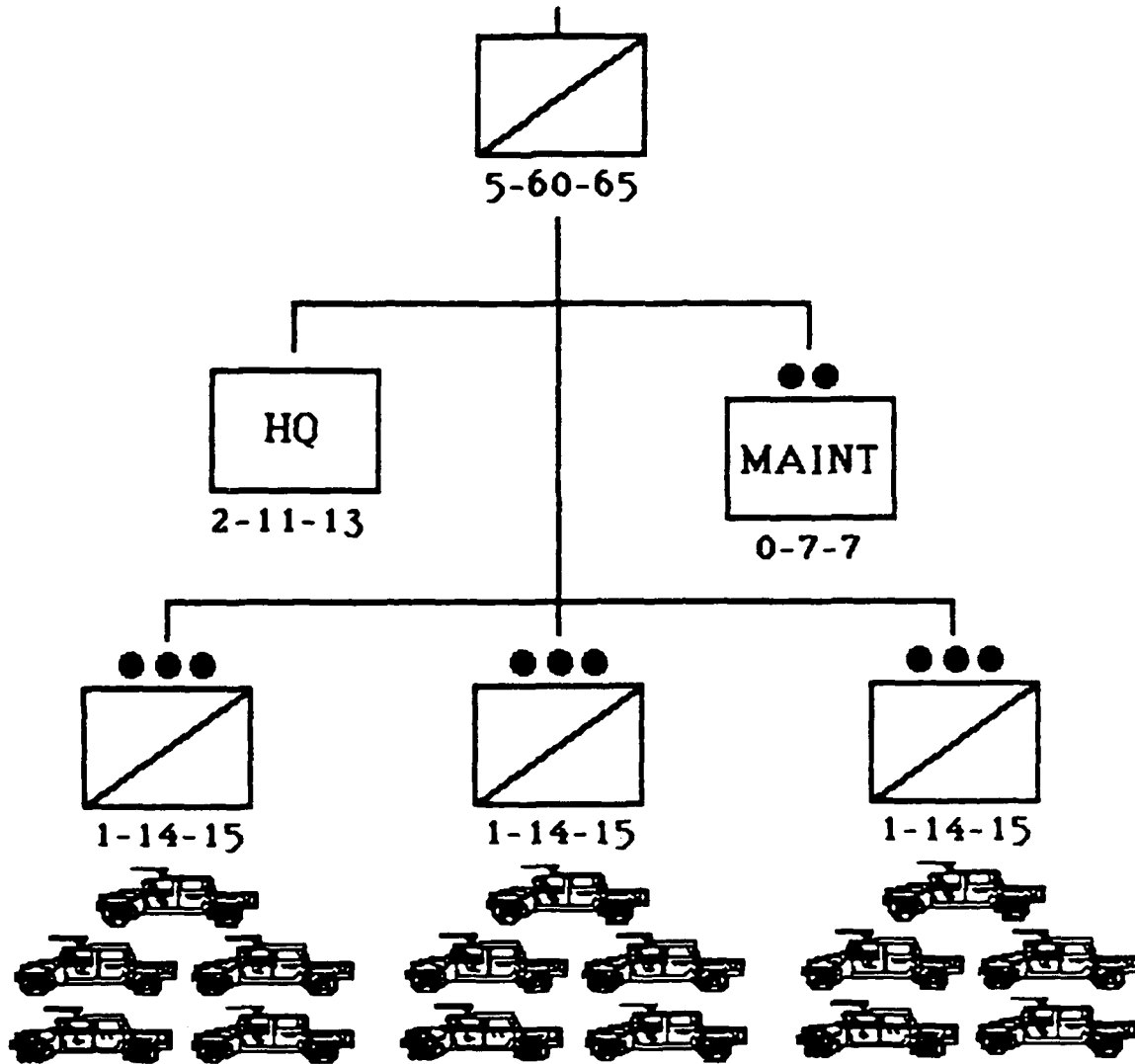

## ENDNOTES

<sup>1</sup>Martin Goldsmith and James Hodges, *Applying the National Training Center Experience: Tactical Reconnaissance* (Santa Barbara, CA: The RAND Corporation, October 1987), p. 4.

<sup>2</sup>General Officer Executive Council (GOEC) Conference on Reconnaissance and Security, Fort Leavenworth, KS, 30 September 1988.

<sup>3</sup>15 August 1988 comments quoted at GOEC Conference.

<sup>4</sup>Robert Patterson, "The Other Side of the Hill: Reconnaissance and Surveillance on the European Battlefield," *NATO's Sixteen Nations* July 1986, p. 63. The definitions set forth in this section are extracted from Field Manual 101-5-1, *Operational Terms and Symbols* (Washington, DC: Department of the Army).

<sup>5</sup>The definitions in this section are extracted from Field Manual 101-5-1, *Operational Terms and Symbols*, Washington, DC: Department of the Army, October 1985.

<sup>6</sup>Sun Tzu, *The Art of War*, translated by Samuel B. Griffith (London: Oxford University Press, 1963), p. 144.

<sup>7</sup>Sun Tzu, *Art of War*, p. 145.

<sup>8</sup>Carl von Clausewitz, *On War*, edited by Michael Howard and Peter Paret (Princeton, NJ: Princeton University Press, 1984), p. 117.

<sup>9</sup>Clausewitz, *On War*, p. 117.

<sup>10</sup>Henri Jomini, *The Art of War*, p. 267. The "forming of hypotheses of probabilities" is akin to the current practice of "templating" or forming a calculated guess as to the enemy's situation based on the study of his doctrine.

<sup>11</sup>Jomini, *The Art of War*, p. 268.

<sup>12</sup>Jomini, *The Art of War*, p. 268.

<sup>13</sup>Jomini, *The Art of War*, p. 273.

<sup>14</sup>Lieutenant Colonel Wayne M. Hall, *Principles of Reconnaissance* (Unpublished paper, Fort Bragg, NC, September 1988), pp. 6-13.

<sup>15</sup>Table of Organization A, *Armored Division*, Headquarters, Armored Force, 1 January 1942.

<sup>16</sup>Table of Organization 17, *Armored Division*, Headquarters, Armored Force, 1 March 1942.

<sup>17</sup>Table of Organization 17, *Armored Division*, Headquarters, Armored Force, 15 September 1943.

<sup>18</sup>Christopher R. Gabel, *The 4th Armored Division in the Encirclement of Nancy* (Fort Leavenworth, KS: Combat Studies Institute, US Army Command and General Staff College, April 1986), p. 3.

<sup>19</sup>Gabel, *The 4th Armored Division in the Encirclement of Nancy*, p. 12.

<sup>20</sup>Colonel Theodore C. Matakis and Lieutenant Colonel Seymour L. Goldberg, *Nuclear Tactics, Weapons, and Firepower in the Pentomic Division, Battle Group, and Company* (Harrisburg, PA: The Military Publishing Company, 1958), pp. 107-108 and Major William A. Noid and Captain James L. Morrison, Jr., "Armor Calls Your Shots," *Armor*, September-October 1958, p. 16.

21 Table of Organization and Equipment 17-22T ROCAD, *Headquarters and Headquarters Company, Combat Command, Armored Division*, Headquarters, Continental Army Command, Fort Monroe, VA, 1 December 1956.

22 Briefing for General Herbert B. Powell, CG, CONARC, 23 December 1960.

23 *After Action Report on CONARC Conference on ROAD-65* held at Fort Leavenworth, KS 24-26 January 1961 and TOE 17-42E (Draft), 19 May 1961.

24 *Commander's Evaluation Report, ROAD Division*, Headquarters, 1st Armored Division, Fort Hood, TX, 18 July 1962, p. 6.

25 Colonel James M. Gibson, "The Separate Brigade," *Military Review*, May 1970, p. 82.

26 *Division Restructuring Study, Brigade Evaluation (Phase III Organization Development)*, US Army Combined Arms Combat Development Activity, Fort Leavenworth, KS, December 1979, p. 3-269.

27 *Division Restructuring Study, Brigade Evaluation (Phase III Organization Development)*, pp. 3-269-3-270.

28 *Division Restructuring Study, Brigade Evaluation (Phase III Organization Development)*, p. 1-9.

29 *Army of Excellence Final Report (Volume III, The Heavy Division)*, US Army Combined Arms Combat Development Activity, Fort Leavenworth, KS, 1 October 1984, p. 2-5.

30 For an in-depth discussion on the austere nature of the AOE divisional cavalry squadron, see Major Peter S. Kindsvatter, "The Army of Excellence Divisional Cavalry Squadron--A Doctrinal Step

Backward?" Student monograph, School of Advanced Military Studies, US Army Command and General Staff College, Fort Leavenworth, KS, 2 December 1985.

<sup>31</sup>Field Manual 71-3, *Armored and Mechanized Infantry Brigade* (Washington, DC: Department of the Army, May 1988), p. 1-2.

<sup>32</sup>Major Raymond D. Barrett, Jr., "Coherence Between AirLand Battle and Contemporary Force Structure at Corps, Division, and Brigade Level." MMAS thesis, US Army Command and General Staff College, Fort Leavenworth, KS, 1985, p. 68.

<sup>33</sup>Lieutenant General Crosbie E. Saint and Colonel L.D. Holder, *III Corps Maneuver Booklet* (Fort Hood, TX: Department of the Army, Headquarters, III Corps and Fort Hood, May 1987), p. 77.

<sup>34</sup>Field Manual 71-3, *Armored and Mechanized Infantry Brigade*, p. 2-1.

<sup>35</sup>Burkhardt, "Brigade Organization and the AirLand Battle," p. 28.

<sup>36</sup>Saint and Holder, *III Corps Maneuver Booklet*, p. 78.

<sup>37</sup>Barrett, "Coherence Between AirLand Battle and Contemporary Force Structure at Corps, Division, and Brigade Level," p. 87.

<sup>38</sup>Saint and Holder, *III Corps Maneuver Booklet*, p. 77.

<sup>39</sup>Burkhardt, "Brigade Organization and the AirLand Battle," p. 11.

<sup>40</sup>Burkhardt, "Brigade Organization and the AirLand Battle," p. 12.

<sup>41</sup>Field Manual 71-3, *Armored and Mechanized Infantry Brigade*, p. 1-3.

<sup>42</sup>Field Manual 71-3, *Armored and Mechanized Infantry Brigade*, p. 1-3.

<sup>43</sup>Field Manual 71-3, *Armored and Mechanized Infantry Brigade*, p. 1-5.

<sup>44</sup>Field Manual 34-80, *Brigade and Battalion Intelligence and Electronic Warfare Operations* (Washington, DC: Department of the Army, May 1988), p. 1-4.

<sup>45</sup>Field Manual 34-80, *Brigade and Battalion Intelligence and Electronic Warfare Operations*, p. 4-42.

<sup>46</sup>Saint and Holder, *III Corps Maneuver Booklet*, p. 78.

<sup>47</sup>Barrett, "Coherence Between AirLand Battle and Contemporary Force Structure at Corps, Division, and Brigade Levels," p. 87. For an additional discussion on the austere nature of the AOE divisional cavalry squadron, see Major Peter S. Kindsvatter, "The Army of Excellence Divisional Cavalry Squadron--A Doctrinal Step Backward?" Student monograph, School of Advanced Military Studies, US Army Command and General Staff College, Fort Leavenworth, KS, 2 December 1985.

<sup>48</sup>Barrett, "Coherence Between AirLand Battle and Contemporary Force Structure at Corps, Division, and Brigade Levels," p. 102.

<sup>49</sup>Field Manual 34-80, *Brigade and Battalion Intelligence and Electronic Warfare Operations*, p. 2-65.

50 David C. Isby, *Weapons and Tactics of the Soviet Army* (London: Janes' Publishing Company, Ltd., 1988), p. 371.

51 Major Myron J. Griswold, "Counterreconnaissance Operations of the Heavy Battalion Task Force on the AirLand Battlefield." Student monograph, School of Advanced Military Studies, US Army Command and Staff College, Fort Leavenworth, KS, 16 December 1985, p. 10.

52 Griswold, "Counterreconnaissance Operations of the Heavy Battalion Task Force on the AirLand Battlefield," p. 11

53 Isby, *Weapons and Tactics of the Soviet Army*, p. 371.

54 Isby, *Weapons and Tactics of the Soviet Army*, p. 373.

55 Field Manual 100-2-1, *The Soviet Army: Operations and Tactics* (Washington, DC: Department of the Army, 16 July 1984), p. 5-2.

56 RB 100-3, *Interoperability of British, Canadian, German, and United States Forces* (Fort Leavenworth, KS: US Army Command and General Staff College, November 1983), p. 2-8.

57 David C. Isby and Charles Kamps, Jr., *Armies of NATO's Central Front* (London: Janes' Publishing Company, Ltd., 1985), p. 184.

58 Isby and Kamps, *Armies of NATO's Central Front*, p. 247.

59 Isby and Kamps, *Armies of NATO's Central Front*, p. 91.

60 Isby and Kamps, *Armies of NATO's Central Front*, pp. 86-87.

61 Lieutenant General J. Fox, "The Restructuring of the Canadian Army," *NATO's Sixteen Nations*, October 1988, p. 20.

62 Isby and Kamps, *Armies of NATO's Central Front*, pp. 120-123.

63 "Center for Army Lessons Learned (CALL) Priority Issue: Tactical Reconnaissance." Letter to CALL from Headquarters, National Training Center and Fort Irwin, Fort Irwin, CA, 9 January 1987, p. 1.

64 "CALL Priority Issue: Tactical Reconnaissance," Fort Irwin, CA, p. 3.

65 "CALL Priority Issue: Tactical Reconnaissance." Letter to CALL from Headquarters, 24th Infantry Division (Mechanized) and Fort Stewart, Fort Stewart, GA, 5 February 1987, pp. 1-2.

66 "CALL Priority Issue: Tactical Reconnaissance." Letter to CALL from Headquarters, III Corps and Fort Hood, Fort Hood, TX, 6 February 1987, p. 1.

67 "CALL Priority Issue: Tactical Reconnaissance," Fort Hood, TX, p. 2.

68 "CALL Priority Issue: Tactical Reconnaissance," Letter to CALL from Doctrinal Division, Center for Army Tactics, US Army Command and General Staff College, Fort Leavenworth, KS, 14 January 1987, p. 3.

69 "CALL Priority Issue: Tactical Reconnaissance." Letter to CALL from Headquarter, Department of the Army (DAMO-FDI), Washington, DC, 20 January 1987, p. 3.

70 US Army Armor School, "Cavalry/Reconnaissance Net Assessment-Master Plan, Fort Knox, KY, 1 August 1988, p. 15.

71 "CALL Priority Issue: Tactical Reconnaissance." Letter to CALL from Headquarters, US Army Missile Command, Redstone Arsenal, AL, 25 February 1987, p. 1.



<sup>72</sup>Colonel(P) Wesley K. Clark, "The Penetration: The Brigade Task Force in the Attack," *Military Review*, October 1988, p. 41.

<sup>73</sup>Interview with Colonel(P) Clark, 17 October 1988.

## BIBLIOGRAPHY

### ***Books***

- Clausewitz, Carl von. *On War*. Edited and translated by Michael Howard and Peter Paret, Princeton, NJ: Princeton University Press, 1984.
- Forty, George. *US Army Handbook 1939-1945*. New York: Charles Scribner's Sons, 1980.
- Hemsley, John. *Soviet Troop Control: The Role of Command Technology in the Soviet Military System*. London: Brassey's Publishers, Ltd., 1982.
- Isby, David C. and Charles Kamps, Jr. *Armies of NATO's Central Front*. London: Jane's Publishing Company, Ltd., 1985.
- Isby, David C. *Weapons and Tactics of the Soviet Army*. London: Jane's Publishing Company, Ltd., 1988.
- Ivanov, D.A., V.P. Savel'yev, and P.V. Shemansky. *Fundamentals of Tactical Command and Control: A Soviet View*. Washington, DC: Department of the Air Force, 1977.
- Jomini, Henri. *The Art of War*. Translated by G.H. Mendell and W.P. Craighill. West Port, CT: Greenwood Press, 1977.
- Messenger, Charles. *Anti-Armor Warfare*. London: Ian Allan, Ltd., 1985.
- Matakis, Colonel Theodore C. and Lieutenant Colonel Seymour L. Goldberg. *Nuclear Tactics, Weapons, and Firepower in the Pentomic Division, Battle Group, and Company*. Harrisburg, PA: The Military Service Publishing Company, 1958.
- Modern Reconnaissance: A Collection of Articles from the Cavalry Journal*. Harrisburg, PA: The Military Service Publishing Company, 1944.

Savkin, V. Ye. *The Basic Principles of Operational Art and Tactics: A Soviet View*. Washington, DC: Department of the Air Force, 1972.

Sidorenko, A.A. *The Offensive: A Soviet View*. Washington, DC: Department of the Air Force, 1970.

Sun Tzu. *The Art of War*. Translated by Samuel B. Griffith. London: Oxford University Press, 1963.

### **Student Monographs and Theses**

Barrett, Major Raymond D., Jr. "Coherence Between AirLand Battle and Contemporary Force Structure at Corps, Division, and Brigade Level." MMAS thesis, US Army Command and General Staff College, Fort Leavenworth, KS, 1985 (CARL Ref. ADB097703-3).

Burkhardt, Major Robert W. "Brigade Organization and the AirLand Battle." Student monograph, School of Advanced Military Studies, US Army Command and General Staff College, Fort Leavenworth, KS, 2 December 1985 (CARL Ref. ADA168920).

Crow, Major Charles L. "The J-Series Cavalry Squadron and Its Reconnaissance Mission." Student monograph, School of Advanced Military Studies, US Army Command and General Staff College, Fort Leavenworth, KS, 13 December 1985 (CARL Ref. ADA167251-2).

Griswold, Major Myron J. "Counterreconnaissance Operations of the Heavy Battalion Task Force on the AirLand Battlefield." Student monograph, School of Advanced Military Studies, US Army Command and General Staff College, Fort Leavenworth, KS, 16 December 1985 (CARL Ref. ADB101812-2).

Kindsvatter, Major Peter S. "The Army of Excellence Divisional Cavalry Squadron--A Doctrinal Step Backward?" Student Monograph, School of Advanced Military Studies, US Army Command and General Staff College, Fort Leavenworth, KS, 2 December 1985 (CARL Ref. ADA167712).

Noyes, Major Nathen Winn. "An Assessment of the Adequacy of the Reconnaissance and Security Forces in the Infantry Division (Light)." MMAS Thesis, US Army Command and General Staff College, Fort Leavenworth, KS, 1985 (CARL Ref. ADB099184-3).

Quinlan, Major Kevin. "The Army of Excellence Divisional Cavalry Squadron." Student monograph, School of Advance Military Studies, US Army Command and General Staff College, Fort Leavenworth, KS, 5 January 1986 (CARL Ref. ADA181009-1).

Rozelle, Major H. Joseph. "The Armored and Mechanized Division Armored Cavalry Squadron." MMAS Thesis, US Army Command and General Staff College, Fort Leavenworth, KS, 1977 (CARL Ref. ADA042867).

### ***Journal Articles***

Beall, Colonel John A. "Revisions to ROCAD." *Armor*, March-April 1959, pp. 48-51.

Benz, K.G. "Fire and Manoeuvre: The German Armoured Corps and Combined Arms Operations." *International Defense Review*, no. 4, 1984, pp. 473-478.

Boudinot, Captain Burton S. "Armed Reconnaissance-Tactical Integration of Aerial Elements." *Armor*, September-October 1961.

Brigade and Battalion Operations Department, USAIS. "The Final ROAD." *Infantry*, November-December 1963, pp. 44-49.

Callahan, Michael B. "Reconnaissance, Surveillance, and Target Acquisition for Follow-On Forces Attack." *Signal*, October 1987, pp. 83-89.

Canadian Liaison Staff, Headquarters II (GE) Corps. "The New Structure of the German Armed Forces." *Canadian Defense Quarterly*, Spring 1975, pp. 13-17, 39.

Clark, Colonel(P) Wesley K. "The Penetration: Brigade Task Force in the Attack." *Military Review*, October 1988.

Davis, Second Lieutenant Geoffrey C. "The Three D's of Reconnaissance." *Armor*, March-April 1982, pp. 24-25.

Demitz, Major Robert S. "The Reconnaissance Squadron, Armored Division." *Military Review*, November 1943.

Dempster, Major D.L. "Remotely Piloted Vehicles for Target Acquisition and Battlefield Surveillance: An Urgent Requirement." *Canadian Defense Quarterly*, Autumn 1985, pp. 21-27.

Donnelly, Chris. "Soviet Reconnaissance-II." *Journal of the Royal United Services Institute for Defense Studies (RUSI)*, March 1976, pp. 68-75.

Edelmaier, Hans. "Light Reconnaissance Vehicles." *Armada* no. 5, 1986, pp. 16-28.

Fisher, Major Paul M. and Captain George C. Hoffmaster, Jr. "Armored Division Organization and Doctrine." *Armor*, September-October 1958, pp. 6-13.

Foss, Colonel John W., Colonel Donald S. Pihl, and Lieutenant Colonel Thomas E. Fitzgerald. "The Division Restructuring Study: The Heavy Division." *Military Review*, March 1977, pp. 11-21.

Fox, Lieutenant General J. "The Restructuring of the Canadian Army." *NATO's Sixteen Nations*, October 1988, pp. 20-25.

Galitsan, Colonel A. "Combat Reconnaissance." *Soviet Military Review*, December 1980, pp. 26-27.

Garcia, Captain Rafael G. "The Reconnaissance Platoon." *Armor*, January-February 1965, pp. 55-57.

German Army Armor School. "The German Armored Combat Troops." *Infantry*, May-June 1983, pp. 24-27.

- Gibson, Colonel James M. "The Separate Brigade." *Military Review*, May 1970, pp. 82-86.
- Gredasov, Lieutenant General F. "Reconnaissance in Modern Battle." *Soviet Military Review*, June 1984, pp. 14-17.
- Hall, Major(P) Wayne M. "Learning to Focus Combat Power." *Military Review*, March 1988, pp. 64-74.
- Heymont, Lieutenant Colonel Irving. "Combat Surveillance." *Military Review*, October 1958, pp. 66-70.
- Holder, Lieutenant Colonel Oliver E. and Major Frederick G. Lee. "The Armoured Regiment of the RAC." *Armor*, September-October 1985.
- Hollis, Colonel Charles H. "This is a ROAD Brigade." *Army*, April 1963, pp. 31-35.
- Hollis, Lieutenant Colonel James B., Jr. "Screen, Cover, Guard: What's the Difference?" *Military Review*, July 1983, pp. 67-72.
- Infantry School. "Motorized Reconnaissance in the Infantry Division." *Infantry School Quarterly*, July 1949, pp. 114-130.
- King, Captain Marc A. "The Battalion Scout Platoon is Alive and Well." *Armor*, September-October 1978, pp. 35-37.
- Kirkegaard, Major Paul J. "Brigade: Casualty of Technology?" *Infantry*, January-February 1972, pp. 46-48.
- Kitson, Frank. "The New British Armoured Division." *Journal of the Royal United Services Institute for Defense Studies (RUSI)*, March 1977, pp. 17-19.
- Kolasheski, Lieutenant Colonel Richard F. "A Battalion Commander's View of Division Restructuring." *Armor*, November-December 1978, pp. 18-23.

Korotchenko, Lieutenant General I. "Reconnaissance." *Soviet Military Review*, June 1983, pp. 44-45.

Leonhard, Captain Robert R. "Counter-Reconnaissance Company." *Infantry*, January-February 1988, pp. 23-26.

Loubens, Colonel Arnaud P. and Captain Marcel M. Valetin. "The French Armored Division." Part I, *Armor*, September-October 1980, pp. 22-25, and Part II, *Armor*, July-August 1981, pp. 58-61.

Millener, Captain George A., Jr. "Battle Group R&S Forces." *Infantry*, March-April 1961, pp. 18-21.

Mitchell, Captain Rodney B. "Reconnaissance Revisited." *Armor*, November-December 1981, pp. 25-27.

Newell, Lieutenant Colonel Clayton R. "Heavy-Light Forces: Divisions or Brigades?" *Infantry*, January-February 1985, pp. 12-13.

Noid, Major William D. and Captain James L. Morrison, Jr. "Armor Calls Your Shots." *Armor*, September-October 1958.

Ozolek, Major David J. "Reconnaissance Planning: A Neglected Art." *Infantry*, March-April 1986, pp. 27-31.

Patterson, Robert. "The Other Side of the Hill: Reconnaissance and Surveillance on the European Battlefield." *NATO's Sixteen Nations* July 1986, pp. 62-65.

Rapp, Captain Joseph H. "The Brigade HQ: Pentomic Infantry Division." *Infantry*, January 1958, pp. 21-24.

Read, Brigadier Greg. "Reconnaissance Forces in the Central Region." *NATO's Fifteen Nations*, no. 1, 1980, pp. 129-134.

Rooney, Lieutenant Colonel Thomas O. "Put the 'Combat' in Combat Reconnaissance." *Military Review*, February 1951, pp. 36-44.

Rosenberg, Lieutenant Colonel Ralph G. and Lieutenant Colonel Michael S. Lancaster. "Command and Control for the Division 86 Squadron." *Military Review*, November 1981, pp. 49-56.

Rosenberger, Major John D. and Colonel Thomas E. White. "Cavalry in the AirLand Battle." *Armor*, January-February 1986, pp. 22-23.

Shimek, Captain Joe E. "Reconnaissance in the Bundewehre." *Armor*, March-April 1964, pp. 34-36.

Stubbs, Kevin D. "Beyond the Army of Excellence." *Military Review*, August 1988, pp. 24-41.

Vargas, Major Kevin J. "What Ever Happened to Tactical Intelligence?" *Military Review*, October 1982, pp. 15-20.

Vigor, P.H. "Soviet Reconnaissance-I." *Journal of the Royal United Services Institute for Defence Studies (RUSI)*, December 1975, pp. 41-45.

Weller, Jac. "Israeli Armor: Lessons from the Six Day War." *Military Review*, November 1973, pp. 44-51.

Whitehair, Lieutenant Colonel Jay C. "Reconnaissance-Sine Qua Non." *Military Review*, October 1943, pp. 8-11.

Wise, Alan R. and Steven M. Shaker. "Over Hill and Dale: Reconnaissance Vehicles." *Journal of Defense & Diplomacy*, October 1986, pp. 51-53.

### **Government Manuals, Reports, and Studies**

*Army of Excellence Final Report: Volume III, Heavy Division* US Army Combined Arms Combat Development Activity, Fort Leavenworth, KS, 1 October 1984 (CARL Ref. N-18968.309).

"Center for Army Lessons Learned (CALL) Priority Issue: Tactical Reconnaissance." 25 November 1986. Letter requests ideas on the issue of tactical reconnaissance from various organizational headquarters Army-wide. Quoted as appropriate.



Christensen, Captain Dee, Captain Robert Plummer, and Major Steve Stanfield. "Enhancement of Reconnaissance and Counterreconnaissance Techniques." United States Army Training Board White Paper, 10 June 1986.

*Division Restructuring Study Brigade Evaluation (Phase III Organization Development)* US Army Combined Arms Combat Development Activity, Fort Leavenworth, KS, December 1979 (CARL Ref. ADB043978L-2).

Field Manual 17-95. *Cavalry Operations* Washington, DC: Department of the Army, 14 February 1986.

Field Manual 34-80. *Brigade and Battalion Intelligence and Electronic Warfare Operations* Washington, DC: Department of the Army, 15 April 1986.

Field Manual 71-3 (Draft). *Armored and Mechanized Infantry Brigade* Washington, DC: Department of the Army, May 1988.

Field Manual 71-100 (Draft). *Division Operations* Washington, DC: Department of the Army, December 1987.

Field manual 100-2-1. *The Soviet Army: Operations and Tactics* Washington, DC: Department of the Army, 16 July 1984.

Field Manual 100-2-3. *The Soviet Army: Troops, Organization, and Equipment* Washington, DC: Department of the Army, 16 July 1984.

Field Manual 100-5, *Operations* Washington, DC: Department of the Army, 5 May 1986.

Field Manual 101-5-1, *Operational Terms and Symbols*. Washington, DC: Department of the Army, October 1985.

Gabel, Christopher R. *The 4th Armored Division in the Encirclement of Nancy*. Fort Leavenworth, KS: Combat Studies Institute, US Army Command and General Staff College, April 1986.

- Gabel, Christopher R. *The Lorraine Campaign: An Overview, September-December 1944*. Fort Leavenworth, KS: Combat Studies Institute, US Army Command and General Staff College, February 1985.
- Goldsmith, Martin, and Hodges, James. *Applying the National Training Center Experience: Tactical Reconnaissance*. Santa Monica, CA: The RAND Corporation, October 1987.
- Greenfield, Kent R., Robert R. Palmer, and Bill I. Wiley. *The Organization of Ground Combat Troops*. Washington, DC: Historical Division, Department of the Army, 1947.
- "Reconnaissance Squadron for Heavy Division 86." Letter from MG Thomas P. Lynch, Commandant, U.S. Army Armor School, to LTG William R. Richardson, Commander, US Army Combined Arms Center, 21 April 1980 (CARL Ref. N-18000.98).
- Reference Book 100-3, *Interoperability of British, Canadian, German, and United States Forces*. US Army Command and General Staff College, Fort Leavenworth, KS, November 1983.
- Reference Data for Armor Units* (R-series TOEs), US Army Armor School, March 1956.
- Reference Data for Armor Units* (ROCAD-ROCID) (T-series TOEs), US Army Armor School, May 1957.
- Reference Data for Armor Units* (Draft D-series TOEs), US Army Armor School, November 1959.
- Reference Data for Armor Units* (E-series TOEs), US Army Armor School, June 1964.
- Reference Data for Armor Units* (D-series TOEs), US Army Armor School, September 1960.
- Report of the Army Field Forces Panel on Armor to the Chief of Staff, US Army (Harmon Board)*. Department of the Army, Fort Monroe, VA, 18 February 1949 (CARL Ref. N-16458-A).

*ROAD-65 Headquarters and Headquarters Company, Armored Division  
Brigade*, US Army Armor School, 19 May 1961.

Rosenberger, Major John D. "An Assessment of Reconnaissance and Counterreconnaissance Operations at the National Training Center." *United States Army Armor School, Fort Knox, KY, February 1987.*

Saint, Lieutenant General Crosbie E. and Colonel L.D. Holder. *III Corps Maneuver Booklet*. Fort Hood, TX: Department of the Army, Headquarters, III Corps and Fort Hood, May 1987.

Table of Organization A: *Armored Division* Department of the Army, Headquarters, Armored Force, 1 January 1942.

Table of Organization 17: *Armored Division* Department of the Army, Headquarters, Armored Force, 1 March 1942.

Table of Organization 17: *Armored Division* Department of the Army, Headquarters, Armored Force, 15 September 1943.

Table of Organization and Equipment 17-22T ROCAD: *Headquarters and Headquarters Company, Combat Command, Armored Division* Department of the Army, Headquarters, Continental Army Command, Fort Monroe Virginia, 1 December 1956.

### ***Interviews***

Clark, Colonel(P) Wesley K. Interview conducted 17 October 1988, Fort Leavenworth, KS. COL(P) Clark is a former heavy brigade commander in the 4th Infantry (Mechanized) Division and former Chief, Operations Group, National Training Center, Fort Irwin, CA. He is currently the director of the Battle Command Training Program, Fort Leavenworth, KS.

Hall, Lieutenant Colonel Wayne M. Interview conducted 28 October 1988 at Fort Leavenworth, KS. LTC Hall is presently the G2, 82d Airborne Division, Fort Bragg, NC.