

0115 FILE CASE

ARO 21885.1-EL

2

**Adaptive Gigabit Fiber Optics
Local Area Network**

Final Report

C. Yeh and M. Gerla

July 11, 1989

**U.S. Army Research Office
DAAG29-85-K-0101**

**School of Engineering and Applied Science
University of California
Los Angeles, CA 90024**

**S DTIC
ELECTE
AUG 07 1989
B D**

**Approved for Public Release,
Distribution Unlimited**

89 7 31 131

AD-A210 794

SECURITY CLASSIFICATION OF THIS PAGE

REPORT DOCUMENTATION PAGE

1a. REPORT SECURITY CLASSIFICATION Unclassified		1b. RESTRICTIVE MARKINGS	
2a. SECURITY CLASSIFICATION AUTHORITY		3. DISTRIBUTION/AVAILABILITY OF REPORT Approved for public release; distribution unlimited.	
2b. DECLASSIFICATION/DOWNGRADING SCHEDULE		4. PERFORMING ORGANIZATION REPORT NUMBER(S) EE-ARO-1001	
4. PERFORMING ORGANIZATION REPORT NUMBER(S) EE-ARO-1001		5. MONITORING ORGANIZATION REPORT NUMBER(S) ARO 21885.1-EL	
6a. NAME OF PERFORMING ORGANIZATION UCLA	6b. OFFICE SYMBOL (if applicable)	7a. NAME OF MONITORING ORGANIZATION U. S. Army Research Office	
6c. ADDRESS (City, State, and ZIP Code) Los Angeles, CA 90024		7b. ADDRESS (City, State, and ZIP Code) P. O. Box 12211 Research Triangle Park, NC 27709-2211	
8a. NAME OF FUNDING/SPONSORING ORGANIZATION U. S. Army Research Office	8b. OFFICE SYMBOL (if applicable)	9. PROCUREMENT INSTRUMENT IDENTIFICATION NUMBER DAAG29-85-K-0101	
8c. ADDRESS (City, State, and ZIP Code) P. O. Box 12211 Research Triangle Park, NC 27709-2211		10. SOURCE OF FUNDING NUMBERS	
		PROGRAM ELEMENT NO DAAG29	PROJECT NO. 85
		TASK NO. K	WORK UNIT ACCESSION NO. 0101
11. TITLE (Include Security Classification) Adaptive Gigabit Fiber Optics Local Area Network (unclassified)			
12. PERSONAL AUTHOR(S) C. Yeh and M. Gerla			
13a. TYPE OF REPORT Final	13b. TIME COVERED FROM 4-1-85 TO 4-14-89	14. DATE OF REPORT (Year, Month, Day) 1989, July 11	15. PAGE COUNT 12
16. SUPPLEMENTARY NOTATION The view, opinions and/or findings contained in this report are those of the author(s) and should not be construed as an official Department of the Army position, policy, or decision, unless so designated by other documentation.			
17. COSATI CODES		18. SUBJECT TERMS (Continue on reverse if necessary and identify by block number)	
FIELD	GROUP	SUB-GROUP	
19. ABSTRACT (Continue on reverse if necessary and identify by block number) This is a final report on the investigation of adaptive gigabit fiber optics local area network. The following tasks were completed.			
<ul style="list-style-type: none"> (a) exploration of tree topologies with passive taps (Tree-Net), (b) investigation of novel, adaptive access scheduling mechanisms (Virtual Queue), (c) use of time division slot switching for the interconnection of FOLANs and the implementation of regular network topologies (e.g. Manhattan grid), (d) use of Wavelength Division Multiplexing (WDM) in order to increase the throughput capacity and functionality of Tree-Net, (e) development of a simple (from the implementation standpoint) and yet efficient protocol - RATO-NET - for a twin, unidirectional fiber bus architecture, ... (f) implementation of an experimental RATO-NET, and comparison of the experimental results with analysis and simulation. 			
20. DISTRIBUTION/AVAILABILITY OF ABSTRACT <input type="checkbox"/> UNCLASSIFIED/DUNLIMITED <input type="checkbox"/> SAME AS RPT. <input type="checkbox"/> DTIC USERS		21. ABSTRACT SECURITY CLASSIFICATION Unclassified	
22a. NAME OF RESPONSIBLE INDIVIDUAL CAYOUR YEH		22b. TELEPHONE (Include Area Code) (713) 8257770	22c. OFFICE SYMBOL

Adaptive Gigabit Fiber Optics LAN

ARO Final Report ARMY DAAG29-85-K-0101

**Cavour Yeh and Mario Gerla
June 1989**

The main research topic defined in our Proposal was the investigation of FOLAN architectures suitable for gigabit operation. In this area, we report progress in these directions:

- (a) exploration of tree topologies with passive taps (Tree-Net)
- (b) investigation of novel, adaptive access scheduling mechanisms (Virtual Queue)
- (c) use of time division slot switching for the interconnection of FOLANs and the implementation of regular network topologies (e.g. Manhattan grid)
- (d) use of Wavelength Division Multiplexing (WDM) in order to increase the throughput capacity and functionality of Tree-Net
- (e) development of a simple (from the implementation standpoint) and yet efficient protocol - RATO-NET - for a twin, unidirectional fiber bus architecture
- (f) implementation of an experimental RATO-Net, and comparison of the experimental results with analysis and simulation.

The results in these areas are summarized below.

1. Tree Network Architectures

As part of our investigation of FOLAN topologies, we have studied tree structured configurations. This study was promoted by some remarkable properties of the tree topology, namely: the ability to cover large metropolitan areas in a cost-effective way; and, the ability to support large station populations, since the number of stations grows exponentially with the number of intermediate taps (as opposed to the linear growth observed in linear bus topologies). Our study has culminated with the design of Tree Net, a tree structured FOLAN suitable for Gbps operation and for metropolitan area coverage.

In [Gerl88B] we describe the basic Tree-Net architecture and evaluate its access delay and connectivity (i.e. maximum number of connected stations). We show that up to 100 stations can be supported in a totally passive network without amplification. If intermediate amplification is used, up to 1,000,000 stations can be connected. In [Gerl88C] we compare Tree-Net to other tree structured networks and show its superiority in handling higher traffic rates (because of the absence of serial processing nodes). We also discuss several variants to the implicit token access scheme presented in [Gerl88D]. In [Gerl88E] we compare Tree-Net with current MAN proposals (DQDB, Metrocore, FDDI II). We claim that Tree-Net offers advantages in the following areas: (1) ability to support higher data rates; (2) ability to support more flexible scheduling policies (this is an important property in integrated services networks); (3) WDM compatibility. In [Oshi88] we discuss a possible implementation of WDM on Tree-Net and show that substantial throughput and delay improvements can be obtained using this technique.

2. Access Schemes

For the family of multiaccess broadcast channel FOLANs, novel schemes for voice/data integration were investigated. The conventional integration policy consists of scheduling distinct voice/data "trains" and allow round robin access to data stations during the data train [Toba83]. The drawback of this approach is the difficulty in achieving efficiency, fairness and delay constraint enforcement at the same time. We have developed a new method, based on the concept of a global, "virtual" FCFS data queue. This virtual queue is known to all stations. The position in the queue is used to schedule packet transmissions. This scheme removes the limitations of previous schemes. It also permits efficient implementation of priorities.

The Virtual Data Queue scheme was described in [Sun88A]. An evaluation of its performance and comparison with other integration schemes was presented in [Sun88B]. The results are encouraging; they show that substantial performance improvements can be obtained at the cost of a slightly more complex access scheme. This additional complexity however does not affect the throughput performance of the network interface since the bookkeeping of reservations and the global queue computation are performed in the background.

3. Time Division Slot Switching

Conventional LAN interconnection schemes are based on packet store-and-forward devices (bridges, routers, gateways). Unfortunately, the packet processing required in such devices involves substantial overhead and cannot be easily scaled up to Gbps speeds. As an alternative to packet switching, we have investigated a strategy borrowed from circuit switching, namely, time division slot switching. In particular, we have studied the feasibility of time division slot switching in regular FOLAN configurations [Sun89]. The topology is similar to the grid topology presented in [Max85]. The protocol, however, is different in that we assume TDM slotting along horizontal and vertical directions. A packet fits exactly in a slot, and slots can be reserved for real time (voice, video, image etc.) connections. At crosspoints, real time packets are switched through "on the fly" (if slots were reserved); while data packets may be buffered and delayed. Since real time traffic is predominant in high speed FOLANs, the scheme drastically

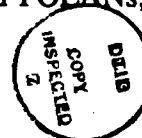

<input checked="" type="checkbox"/>	
<input type="checkbox"/>	
<input type="checkbox"/>	
	Codes
	and/or
	Special
A-1	

reduces nodal processor overhead. The basic architecture can be extended by replacing each link with a slotted bus (or other suitable FOLAN) to which several stations are in turn connected. In this context, time division slot switching can be viewed as a network interconnection strategy.

4. Wavelength Division Multiplexing

WDM is a technique which permits us to multiplex several channels on the same fiber using wavelength division. The main advantages of WDM are:

- exploitation of the enormous bandwidth (up to Terabit/sec) available on the fiber
- creation of separate "logical" subnets on the physical net (for reasons of security, performance, support of different station speeds, etc)
- dynamic reconfiguration of the logical partitions using wavelength agile transmitters and receivers.

We have carried out a preliminary investigation of the impact of WDM on high speed FOLANs. In particular, we have engaged in the following tasks:

- investigation of the physical topologies appropriate for WDM. A basic requirement is that stations be connected to the network via passive taps. This rules out the ring (e.g. FDDI) and the active bus (e.g. DQDB). Candidate topologies are the star, the tree and the passive bus [BG89], [Bann88].
- optimization of the logical topology which is overlaid on top of the physical topology. Acampora et al have proposed ShuffleNet [Acam87]. We have developed a more general methodology for the design of the best topology based on user requirements, performance constraints and switching cost considerations [BG89].
- application of WDM concepts to Tree Net. We have shown that WDM can be effectively used to increase Tree Net throughput capacity and expand its functionality. We can multiplex several "logical" Tree Nets (each operating at a different wavelength) on the same physical Tree Net. Each logical Tree Net can carry a different application (e.g. data, voice, video, image, secure communications, etc) and can be operated using an access scheme specifically selected for that application.

5. RATO-Net Protocol

A new, random access, easy-to-implement protocol RATO (Random Access-Time Out) has been developed and tested for a dual unidirectional bus structure made with optical fibers. Since it allows the packet transmission time to be shorter than the end-to-end propagation time, this protocol is particularly suited for ultra-high bandwidth FOLANs. In addition to having the

feature of guaranteed delay, RATO also assures fairness among all stations. Performance comparison with other known protocol schemes, such as Ethernet, Fastnet, etc., shows that at ultra-high bit-rates over large distances, RATO out-performs all these protocols. Extensive simulation experiments were also carried out; Very close agreement was found between simulation results and the results obtained from analytical formulas.

6. RATO Experiments

Having developed and analyzed a new protocol (RATO) which is particularly suited for high-speed FOLAN, the next step was to build an experimental network implementing the RATO protocol to verify some of the analytical results. To simulate the high-speed FOLAN condition our experimental RATO network must possess the unique feature that end-to-end propagation time be larger than the packet transmission time. Furthermore, a buffer must be built into the interface of each station to simulate the condition of potential mismatched between network speed and terminal speed. A three-station experimental setup, based on a single unidirectional bus configuration with random access time-out protocol network, was built. (See Fig. 1) The three local stations are three IBM-PCs. The needed interfaces with buffer were designed and fabricated. In the laboratory environment the spacing between stations was set to be much less than 1 km. To simulate the condition encountered in very high speed Gbps rate FOLANs for which the propagation delay is much larger than packet transmission time, the delay between transmission of the packet from one station and reception of the packet at the next station was artificially created by electronic means. A block diagram of the interface TNC is shown in Fig. 2. The TNC consists of eight modules: central controller, two buffers, encoder, decoder, line sensor, transmitter, and receiver.

An experiment was carried out to measure throughput as a function of the number of active stations and throughput as a function of packet length. Measured results are compared with calculated results in Figs. 3 and 4. Excellent agreement was found between analysis and measurements.

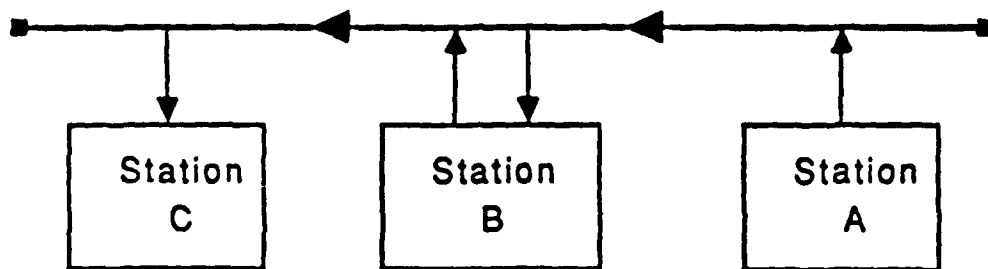

FIGURE 1

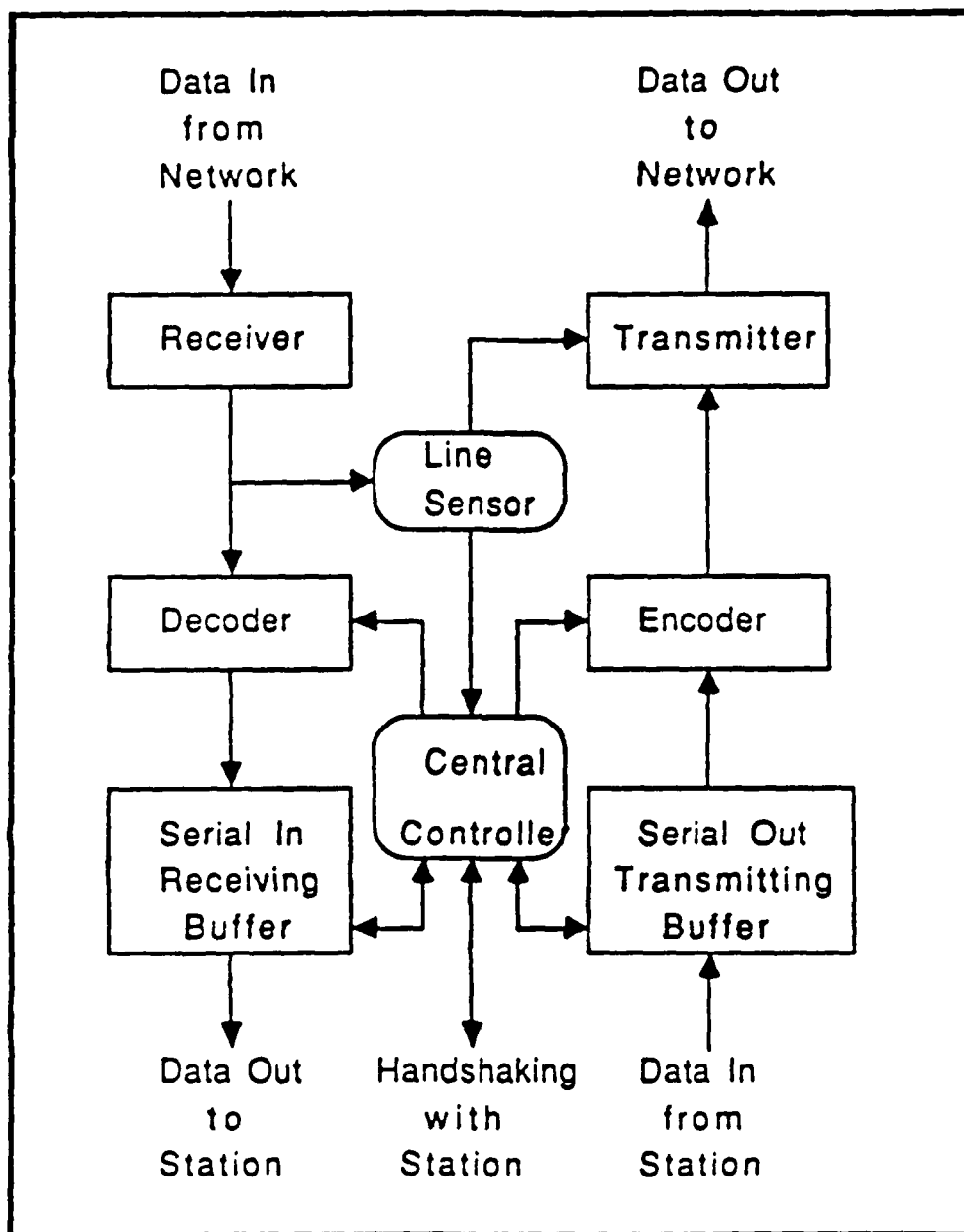

FIGURE 2

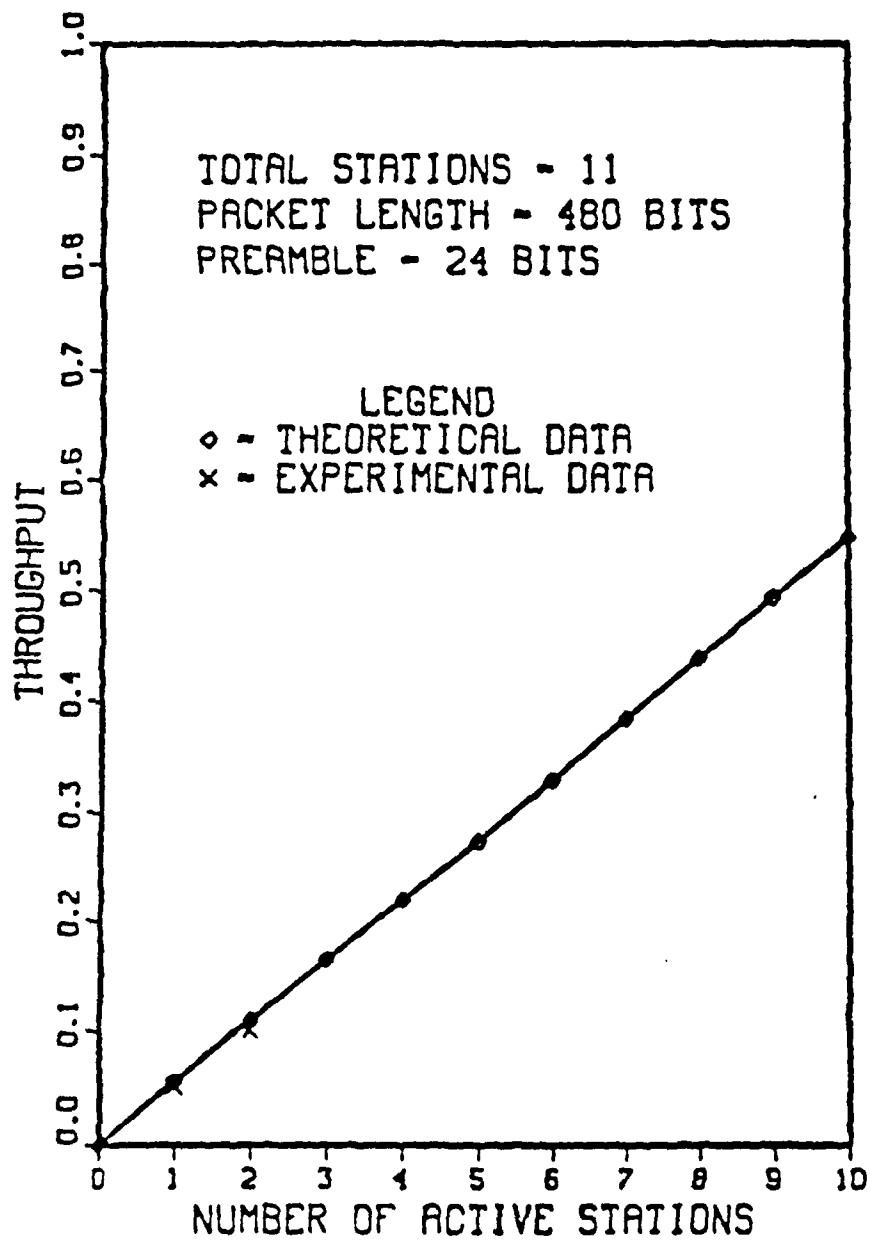

FIGURE 3

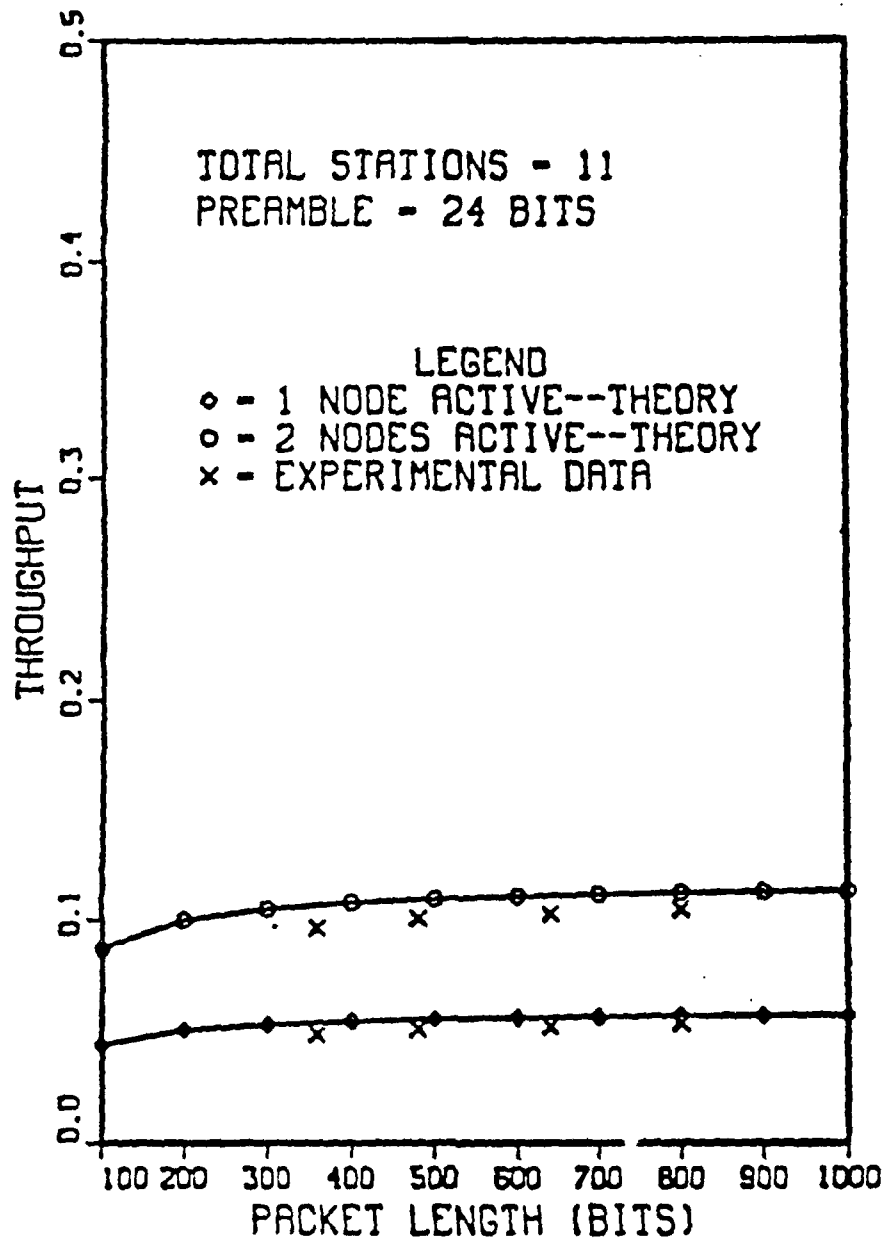

FIGURE 4

7. Publications

The following publications were in part supported by the ARO grant and describe the results of our research.

- Bannister, J. and M. Gerla, "Design of the Wavelength Division Optical Network", *IEEE Metropolitan Area Network Workshop*, Dana Point (San Diego, CA), March 1989. Also, UCLA CSD Technical Report, CSD-890022, May 1989.
- Gerla, M. and L. Kleinrock, "Congestion Control in Interconnected LAN's", *Network Magazine*, January 1988.
- Gerla, M., "Tree-Net, a Multilevel Fiber Optics MAN", *INFOCOM '88*, New Orleans, March 1988.
- Gerla, M. and L. Fratta, "Design and Control in Processor Limited Packet Networks", *International Teletraffic Conference*, Torino, June 1988.
- Gerla, M. and L. Fratta, "Tree Structured Fiber Optics MAN's", *IEEE JSAC*, Vol. 6, No. 6, July 1988.
- Gerla, M. and L. Fratta, "Fiber Optics Trees for Metropolitan Distribution", *FOCLAN Conference Proceedings*, Atlanta, Georgia, Sept. 1988.
- Sun, Y. and M. Gerla, "A Virtual Data Queue Access Scheme for Integrated LANs", *ICCC Conference Proceedings*, Oct. 1988.
- Sun, Y.L. and M. Gerla, "Synchronous Fast Packet Switching (SFPS)- A Hybrid Switching Architecture for B-ISDN", *INFOCOM 89*, Ottawa, Canada, April 1989.
- Oshima, K., M. Gerla and V. Tella, "Access Protocols for Tree Structured Fiber Optics MANs", *International Computer Systems Conference*, Singapore, Nov. 88.
- Yeh, C., M. Lin, M. Gerla, P. Rodrigues, "RATO-Net: A Random-Access Protocol for Unidirectional Ultra-High-Speed Optical Fiber Network", accepted for publication in the *IEEE Transactions for Lightwave Technology*.

8. Personnel

Principal Investigator:

Prof. Cavour Yeh

Co.-Principal Investigator:

Prof. Mario Gerla

Other Research Personnel:

Dr. L. Fratta

Dr. K. Oshima

Y.L. Sun

M. Lin

J. Chu

W. Li

R. Yeh

V. Hsia

S. Kim

V. Tella

F. Schaffa

J. Monteiro

J. Bannister

J. Wills

J. Mahon

9. References

- [Acam87] Acampora, A., "Terabit Lightwave Networks: The Multihop Approach, *AT&T Technical Journal*, Nov./Dec. 1987.
- [Alba88] Albanese, A., et al., "Overview of Bellcore METROCORE Network", Workshop on High Speed LAN's, Liege, Belgium, April 1988.
- [Ansi87] "The High Speed Channel", *ANSI X3T9 Committee Proposal*, March 1987.
- [Bann88] Bannister, J. A. "The WOMAN (Wavelength-division Optical Metropolitan Area Network): Architectures, Topologies, Protocols." PhD Prospectives. UCLA, Comp. Science Dept., Sept. 1988.
- [BG89] Bannister, J. and M. Gerla, "Design of the Wavelength Division Optical Network", *IEEE*, Metropolitan Area Network Workshop, Dana Point, (San Diego, CA) March 1989. Also, UCLA CSD Technical Report, CSD-890022, May 1989.
- [Gerl88B] Gerla, M., "Tree-Net, a Multilevel Fiber Optics MAN", *INFOCOM '88*, New Orleans, March 1988.
- [Gerl88C] Gerla, M. and L. Fratta, "Design and Control in Processor Limited Packet Networks", *International Teletraffic Conference*, Torino, June 1988.
- [Gerl88D] Gerla, M. and L. Fratta, "Tree Structured Fiber Optics MAN's", *IEEE JSAC*, Vol. 6, No. 6, July 1988.
- [Gerl88E] Gerla, M. and L. Fratta, "Fiber Optics Trees for Metropolitan Distribution", *FOCLAN Conference Proceedings*, Atlanta, Georgia, Sept. 1988.
- [Max85] Maxemchuk, N. F., "Regular Mesh Topologies in Local and Metropolitan Area Networks", *AT&T Technical Journal*, September 1985.
- [Oshi88] Oshima, K., M. Gerla and V. Tella, "Access Protocols for Tree Structured Fiber Optics MANs", *International Computer Systems Conference*, Singapore, Nov. 88.
- [Pazo86] Pazos, R. and M. Gerla, "Express Pipe Network Design", 1986 International Zurich Seminar, Zurich, March 1986.
- [Sun88A] Sun Y. and M. Gerla, "A Virtual Data Queue Access Scheme for Integrated LANs", *ICCC Conference Proceedings*, Oct. 1988.

- [Sun88B] Sun, Y. and M. Gerla, "Performance Analysis of a Virtual Data Queue Access Scheme for Integrated Voice/Data LANs," *International Conference on Performance of Distributed and Parallel Processing Systems*, Kyoto, Japan, Dec. 1988.
- [Sun89] Sun, Y. L. and M. Gerla "Synchronous Fast Packet Switching (SFPS) - A Hybrid Switching Architecture for Broadband ISDN", *INFOCOM 89*, Ottawa, Canada, April 1989.
- [Toba83] Tobagi, F. A., "Express-Net: A High Performance Integrated Services LAN", *JSAC*, November 1983.