

THIS FILE COPY

(4)

AD-A210 228

PROGRESS REPORT

DTIC  
ELECTE  
JUN 30 1989  
S D CS D

Source: Department of the Navy  
Office of Naval Research

Report: First Progress Report; June 30, 1989

Project Title: Integration of neurobiological and computational analyses of the neural network essentials for conditioned taste aversions

Grant Number: N00014-89-J-1296

Principal Investigator: Dr. Kathleen C. Chambers

GOALS

The general goal of the ONR project is to determine the neural basis of learning and memory, i.e., how the brain stores and retrieves memory. More specifically we are determining how the hard-wired (innate) part of the neural system interfaces with the plastic (learned) part. The special form of learning which is the focus of this project is conditioned taste aversions (CTAs), i.e., learned aversions to the taste of a food or fluid when consumption of that substance is followed by illness. In order to achieve this general goal, neurobiological and computational analyses of the neural network essentials for CTA are being integrated. The essential neurobiological network for CTA is being identified and characterized and computational models for the CTA neural circuit are being developed.

NEUROBIOLOGICAL RESEARCH

It is necessary to identify four pathways in order to gain a clear understanding of the neural basis of CTAs: the US (illness) pathway, the CS (taste) pathway, the pathway for the elicited response to the CS prior to conditioning (UR<sub>CS</sub> or unconditioned ingestive response, UIR), and the pathway for the elicited response to the CS after conditioning (CR<sub>CS</sub> or unconditioned aversive response, UAR). As much work has already been done on the taste and UR<sub>CS</sub> pathways, we are concentrating on the illness and illness-taste integration pathways in this proposal.

Illness Pathway

We have completed 2 experiments. These were presented as a single poster at the American Psychological Society meetings in June (see Appendix A). Progress also is underway in three other projects.

There are two known detection systems for toxins, the

DISTRIBUTION STATEMENT A  
Approved for public release  
Distribution Unlimited

1 82 04

gastric-intestinal mucosa and the area postrema. The vagus nerve conveys information from the gastric-intestinal mucosa to the nucleus of the solitary tract (NST), pontine parabrachial nucleus (PBN) and the insular cortex (Cechetto & Saper, 1987; Norgren, 1978; Torvik, 1956). The area postrema detects chemicals in the blood and is thought to convey this information to the NST (Morest, 1967). Beyond this little is known about the illness pathways.

A wide variety of substances can induce CTAs. The detection system that is used to convey information about these substances to the brain varies with the particular chemical and the route of administration. LiCl, a widely used illness-inducing agent, acts by way of the area postrema; copper sulfate acts by way of the vagus nerve when it is administered intraperitoneally; and, apomorphine acts by systems other than the area postrema and the vagus nerve.

One of our aims is to determine the conditions under which endogenous substances and motion act as illness-inducing agents in a CTA and to determine the neural pathways by which these agents and the commonly found toxin, LiCl, produce their effect. This work is of vital importance for understanding motion sickness and the effect of stress on behavior.

#### Experimental Series 1: Nature of Toxin

We have completed two studies that examine the role of estradiol, an endogenous hormone found in both males and females, in CTAs (see Appendix A). When estradiol levels are elevated, animals exhibit increases in the rate of extinction of a CTA. This is true when estradiol is elevated only during acquisition or only during extinction. We suggest that this effect can be explained in terms of its nonassociative toxic effects.

#### Experimental Series 2: Neural Pathways

We have initiated three pilot studies which will help us identify the neural pathways for different illness-inducing agents. In the first pilot study, we have worked out the coordinates for locating the area postrema and have completed some practice lesions. In the second pilot study, we have worked out the parameters for 2-DG studies. This procedure will allow us to identify active areas of the brain after administration of illness-inducing agents. In the third pilot study, we have begun to work out the parameters for multiunit recording from the PBN during illness. The coordinates for locating the PBN have been identified and the components for recording are being assembled.

#### **Illness-Taste Integration Pathway**

We have completed 1 experiment aimed at identifying neural areas mediating illness-taste integration. Progress also is underway in one other project.

Handwritten notes and signatures in the right margin, including a signature and the word "Codes" written below it.



Dist	Avail and/or Special
A-1	

### Experimental Series 1: Role of the Amygdala

Several brain structures have been implicated in CTAs, but until recently, lesions of the amygdala (AMY), in particular the basolateral AMY, have produced the most consistent findings; they disrupt acquisition and retention of prelesion CTAs (Aggleton et al., 1981; Nachman & Ashe, 1974; Simbayi et al., 1986). But after finding that cutting the connections between the AMY and the temporal cortex produced the same deficits as lesions of the basolateral AMY, Fitzgerald and Burton (1983) suggested that it is the destruction of the fibers of passage that produces the deficits after lesions of the basolateral AMY and not the destruction of the nucleus itself. Recently, Dunn and Everitt (1988) found that neurotoxin (ibotenic)-induced lesions which spare the fibers of passage had no effect on aversion learning whereas electrolytic (ELEC) lesions which destroy both cells and fibers attenuated the aversion. Neither ibotenic or ELEC lesions had a significant effect on extinction. They concluded that it is the axons passing between the brain stem/hypothalamus and GN that are responsible for the deficits in acquisition after ELEC lesions of the AMY. In the following study, we set out to examine the effect of ELEC and neurotoxin (NMDA, N-methyl-D,L-aspartic acid)-induced lesions on acquisition and extinction of a CTA.

Method. The subjects were 40 Fischer 344 male rats that were 102-117 days old and weighed 295-310 gm. The males were group housed from weaning and were housed 2 per cage during the experiment. They were kept on a 12:12 hr. light/dark cycle (lights off at 1800 hr). They were nondeprived throughout the experiment. The males were randomly divided into 4 groups: nonsurgery control (CONT), sham control (SHAM), ELEC lesion, NMDA lesion.

Under nembutal anesthesia, the males were placed in a Kopf stereotaxic device, the scalp raised and the skull trephined. For the excitotoxin lesion a cannula (30 gauge stainless steel) was inserted, for the ELEC lesion an electrode insulated except at the tip (00 gauge stainless steel, 0.5 mm exposed tip) was inserted, and for the sham control a similar electrode was inserted. Lesions were made at the following coordinates (based on Paxinos and Watson, 1986; incisor bar set at -3.3 mm): 2.9 mm posterior to bregma, lateral +/-5.0 mm, ventral (from dura) - 8.0 mm. The NMDA (12 ug/0.6 ul normal saline) was injected over a 2-3 min period. The cannula was withdrawn after a period of at least 5 min and the amount of time taken to withdraw the cannula was at least 2 min. The ELEC lesion was made by a Grass DC constant current lesion maker set at 0, turned to 2 mamps in 4 sec, and kept at 2 mamps for 30 sec.

A CTA was induced in all males. The experimental procedure was divided into three periods: preconditioning, acquisition, and extinction. During all of these periods, the animals were weighed daily just prior to the end of the light portion of the light/dark cycle. All solutions were stored under refrigeration

for 24 hr before they were given to the animals and were introduced at the beginning of the dark portion of the cycle. The preconditioning period lasted 7 days. The animals were 101-114 days old. During this period the water was replaced for 1 hr with cold tap water in a cylinder. The acquisition period started immediately after termination of the preconditioning period. On acquisition day the water of the animals were replaced with a 10% (w/v) sucrose solution for 1 hr. At the end of this 1 hr period, the amount of solution consumed was recorded for each animal and the animals were injected with a 0.15M LiCl solution (10 ml/kg). Following the injections, the animals were returned to their cages, and the sucrose solution was replaced with tap water. Three days after acquisition the animals underwent surgery and 23 days after surgery, extinction trials were initiated. Extinction trials were given for 40 days. About 2 weeks after behavioral testing the males were deeply anesthetized with nembutal, their brains were removed and post-fixed in a 30% sucrose-formalin solution for at least 48 h prior to sectioning. Sections were cut at 50 micron section thickness on a sliding microtome. Every second section was mounted on a glass slide and stained with cresyl violet. The ELEC lesions were assessed by directly observing the limits of the lesion in the anterior-posterior (AP), dorsal-ventral, and medial-lateral planes. The NMDA lesions were assessed by demarcating the absence of nerve cell bodies and the presence of areas of obvious intense gliosis.

Results. Four CONT males and one SHAM male were eliminated because of insufficient sucrose consumption. Four ELEC animals were eliminated because of deaths or unilateral lesions. The remaining animals sustained complete bilateral damage of the anterior, posterior and ventral aspects of the basolateral AMY region throughout the AP extent (see Figure 1, Appendix B). Typically the lesions were large and damage was sustained to other adjacent areas. Areas frequently lesioned included the basomedial nuclei (BM), dorsal endopiriform nucleus (Dn), piriform cortex (PirC), posterolateral cortical amygdaloid nucleus (PLCo), central nuclei (CE) and lateral nuclei (LA). There also was minimal damage to the posteromedial cortical amygdaloid nucleus (PMCo), intraamygdaloid division of the stria terminalis bed nucleus (BSTIA), caudate putamen (CP) and globus pallidus (GP). Except for the PirC which sustained 50% bilateral damage, these additional areas only had unilateral lesions.

One NMDA animal was eliminated because lesions were unilateral. The remaining animals sustained damage centered in the basolateral region but the extent of AP damage varied from 20-100% with an average of 50% (see Figure 2, Appendix C). Extensive damage to the BM, Dn and LA and minor damage to the PirC, PLCo, CE, PMCo, BSTIA, CP and GP also was sustained. It is important to note that no animals were observed to have seizures (a possible source of damage) following NMDA infusion. Photographs of representative sections from CONT, SHAM, ELEC and NMDA animals are shown in Figure 3 (Appendix D).

Analyses were made of the amount of sucrose solution consumed the first test day after acquisition and the number of days it took an animal to begin drinking within 1 ml of its acquisition day consumption. The four groups of males did not differ in the amount of sucrose consumed on the day of acquisition, but the ELEC animals drank more sucrose the first test day after acquisition than the NMDA and control males ( $F(3,26)=9.4$ ,  $p<0.001$ , Waller Duncan T,  $p<0.05$ ; see Figure 4, Appendix E). The extinction rates of the two groups of controls did not differ and those of the two groups of amygdala-lesioned males did not differ but the control groups extinguished more slowly than the lesioned groups ( $F(3,26)=2.9$ ,  $p<0.05$ , Waller Duncan T,  $p<0.05$ ; see Figure 5, Appendix E).

Conclusion. Like Dunn and Everitt (1988) we found that acquisition of a CTA was attenuated in males with ELEC but not neurotoxin lesions of the AMY. However, whereas they found no effect of either type of lesion on extinction in fluid deprived males, we found faster extinction rates for both types of lesions in nondeprived males. These results suggest that the amygdala plays a role in extinction of a CTA and that neural areas modulating CTAs may be influenced by fluid deprivation conditions.

#### Experimental Series 2: Role of the Gustatory Cortex

Animals with lesions of the gustatory cortex (GN) exhibit slower acquisition of CTAs (Braun et al., 1972) and no retention of a prelesion CTA (Braun et al., 1981; Kiefer et al., 1984; Yamamoto et al., 1980). The effect of GN lesions on extinction is unclear. We have begun a study to determine the effect of GN lesions on acquisition and extinction of a CTA. The lesion was made prior to induction of a CTA. Preliminary review of the data suggest that there is no effect of GN lesions on acquisition of a CTA but the effect on extinction is not yet clear.

#### COMPUTATIONAL RESEARCH

We have completed a paper that lays the groundwork for developing a computational model for CTAs (see Appendix F).

The determination of the neural substrates for CTAs should involve the identification of four pathways: the US pathway, the CS pathway, the pathway for the elicited response to the CS prior to conditioning ( $UR_{cs}$  or unconditioned ingestive response, UIR), and the pathway for the elicited response to the CS after conditioning ( $CR_{cs}$  or unconditioned aversive response, UAR). Each taste is connected to both the ingestive and aversive patterns of responses. These connections are probably innate as hedonic reactions to taste have been observed in fetal and neonatal individuals (Pfaffman 1978, Steiner 1973, 1979).

The relative strengths of the two innate connections are dependent on the given taste. In the case of sucrose, the innate connection to the ingestive response is stronger than the innate

connection to the aversive response. If exposure to sucrose is followed by illness, the connection to the ingestive response system will weaken and the connection to the aversive response system will strengthen. It is most likely that the illness-induced changes involve two rather than one process. Grill and Berridge (1985) have suggested that palatability processing involves two mechanisms and have provided evidence that the ingestive and aversive response systems can change independently. Thus, in order for the aversive response system to be expressed solely, a weakening of the ingestive response system would have to occur. If exposure to sucrose is not followed by negative consequences, a stronger connection to the ingestive response system will result. A stronger connection to the ingestive response system also will occur if a given taste is associated with positive reinforcement or if it is followed by recuperation from illness (Garcia et al 1977, Revusky 1967, 1974, Young 1966). So, experiential factors can alter the strengths of the innate connections to the ingestive and aversive response patterns. Thus, after a given taste is experienced, the relative strengths of the ingestive and aversive response systems are a function of the original innate connections, the number of exposures to sucrose with illness and the number of exposures to sucrose without illness. This hypothesis is supported by the findings that CTAs to nonpreferred tastes are stronger than to preferred tastes (Etscorn 1973), repeated pairings of a taste with illness strengthens an aversion and repeated pairings of a taste without illness reduces the strength of an aversion (Kalat & Rozin 1973).

There are other factors associated with the CS and US that can influence the strength of an aversion and therefore must be taken into account when developing a neural model for CTAs. The strength of an aversion has been found to be a function of the intensity of the taste as measured by concentration (Dragoin 1971) and the amount consumed on the first exposure (Bond & DiGuisto 1975), the intensity of the US (Revusky 1968) and prior experience with the US (Cannon et al 1975).

There are several factors which can modulate the development and strength of CTAs, but are not essential or critical for aversion learning. The development and strength of an aversion is dependent on the hormonal milieu and deprivation state of the animal. The presence of testosterone (T) increases the proportion of animals that develop a CTA (Chambers et al 1981) and the presence of dexamethasone attenuates the strength of an aversion (Hennessy et al 1976). Water deprivation reduces the proportion of male rats that develop an aversion (Chambers et al 1981). It is interesting that deprivation can alter the hedonic value of tastes. Foods are reported to be more palatable with deprivation and less so with satiety (Cabanac 1971). Also, the number of ingestive responses decreases and the number of aversive responses increases as meal termination approaches (Grill & Berridge 1985). So, the relative strengths of the ingestive and aversive response systems are also a function of modulating factors. A complete understanding of the neural mechanisms controlling CTAs would include a determination of the

neural circuitry for the modulating factors.

A neural model for extinction of a CTA can be outlined in a similar manner as acquisition. Extinction is a process by which connections to the aversive response system are weakened and connections to the ingestive response system are strengthened. Any information on the subsequent consequences of ingesting the CS is processed. If the consequences are neutral, that information serves to alter the relative strengths of the two response systems. Thus, after a CS has been experienced without negative consequences, the relative strengths of the ingestive and aversive response systems are a function of the relative strengths of these systems after the CTA, the number of exposures to the taste without illness, modulating factors, and probably the original innate predisposition.

#### REFERENCES

- Aggleton, J. P., Petrides, M. and Iversen, S. D. Differential effects of amygdaloid lesions on conditioned taste aversion learning by rats. Physiology and Behavior, 27, 397-400, 1981.
- Bond, N., Di Giusto, E. Amount of solution drunk is a factor in the establishment of taste aversion. Animal Learning and Behavior, 3, 81-84, 1975.
- Braun, J. J., Kiefer, S. W., and Ouellet, J. V. Psychic ageusia in rats lacking gustatory neocortex. Experimental Neurology, 72, 711-716, 1981.
- Braun, J. J., Slick, T. B., and Lorden, J. F. Involvement of gustatory neocortex in the learning of taste aversions. Physiology and Behavior, 9, 637-641, 1972.
- Cabanac, M. Physiological role of pleasure. Science, 176, 1103-1107, 1971.
- Cannon, D. S., Berman, R. F., Baker, T. B., Atkinson, C. A. Effect of preconditioning unconditioned stimulus experience on learned taste aversions. Journal of Experimental Psychology: Anim. Behav. Proces., 104, 270-284, 1975.
- Cechetto, D. F., Saper, C. B. Evidence for a viscerotopic sensory representation in the cortex and thalamus in the rat. Journal of Comparative Neurology, 262, 27-45, 1987.
- Chambers, K. C., Sengstake, C. B., Yoder, R. L., Thornton, J. E. Sexually dimorphic acquisition of a conditioned taste aversion in rats: Effects of gonadectomy, testosterone replacement and water deprivation. Physiology and Behavior, 27, 83-88, 1981.
- Dragoin, W. B. Conditioning and extinction of taste aversions with variations in intensity of the CS and the UCS in two

- strains of rats. Psychonomic Science, 22, 303-304, 1971.
- Dunn, L. T. and Everitt, B. J. Double dissociations of the effects of the amygdala and insular cortex lesions on the conditioned taste aversion, passive avoidance, and neophobia in the rat using the excitotoxin ibotenic acid. Behavioral Neuroscience, 102, 3-23, 1988.
- Estcorn, F. Effects of a preferred vs a nonpreferred CS in the establishment of a taste aversion. Physiological Psychology, 1, 5-6, 1973.
- Fitzgerald, R. E. and Burton, M. J. Neophobia and conditioned taste aversion deficits in the rat produced by undercutting temporal cortex. Physiology and Behavior, 30, 203-206, 1983.
- Garcia, J., Hankins, W. G., Coil, S. D. Koalas, men and other conditional gastronomes. In Food Aversion Learning, ed. N. W. Milgram, L. Krames, T. Alloway. New York: Plenum Press, 1977.
- Grill, H. J., Berridge, K. C. Taste reactivity as a measure of the neural control of palatability. Progress in Psychobiology, Physiology and Psychology, 11, 1-61, 1985.
- Hennessy, J. W., Smotherman, W. P., Levine, S. Conditioned taste aversion and the pituitary-adrenal system. Behavioral Biology, 16, 413-424, 1976.
- Kalat, J. W., Rozin, P. "Learned safety" as a mechanism in long-delay taste-aversion learning in rats. Journal of Comparative and Physiological Psychology, 83, 198-207, 1973.
- Kiefer, S. W., Leach, L. R., and Braun, J. J. Taste agnosia following gustatory neocortex ablation: Dissociation from odor and generality across taste qualities. Behavioral Neuroscience, 98, 590-608, 1984.
- Morest, D. K. Experimental study of the projections of the nucleus of the tractus solitarius and the area postrema in the cat. Journal of Comparative Neurology, 130, 277-300, 1967.
- Nachman, M. and Ashe, J. H. Effects of basolateral amygdala lesions on neophobia, learned taste aversions, and sodium appetite in rats. Journal of Comparative and Physiological Psychology, 87, 622-643, 1974.
- Norgren, R. Projections from the nucleus of the solitary tract in the rat. Neuroscience, 3, 207-218, 1978.
- Pfaffman, C. The vertebrate phylogeny, neural code, and integrative processes of taste. In Handbook of Perception, ed. E. C. Carterette, M. P. Friedman, VIA:51-123. New York:



Academic Press, 1978.

- Revusky, S. H. Retention of a learned increase in the preference for a flavored solution. Behavioral Biology, 11 121-125, 1974.
- Revusky, S. H. Aversion to sucrose produced by contingent X-irradiation: Temporal and dosage parameters. Journal of Comparative and Physiological Psychology, 65, 17-22, 1968.
- Revusky, S. H. Hunger level during food consumption: Effects on subsequent preference. Psychonomic Science, 7, 109-110, 1967.
- Simbayi, L. C., Boakes, R. A., and Burton, M. J. Effects of basolateral amygdala lesions on taste aversions produced by lactose and lithium chloride in the rat. Behavioral Neuroscience, 100, 455-465, 1986.
- Steiner, J. E. Human facial expressions in response to taste and smell stimulation. In Advances in Child Development, ed. H. W. Reese, L. Lipsett, 13:257-295. New York: Academic Press, 1979.
- Steiner, J. E. The gustofacial response: Observation on normal and anencephalic newborn infants. In Symposium on Oral Sensation and Perception, ed. J. F. Bosma. IV:254-278. Bethesda, Md.: NH-DHEW, 1973.
- Torvik, A. Afferent connections to the sensory trigeminal nuclei, the nucleus of the solitary tract and adjacent structures: An experimental study of the rat. Journal of Comparative Neurology, 106, 51-141, 1956.
- Yamamoto, T., Matsuo, R., and Kawamura, Y. Localization of cortical gustatory area in rats and its role in taste discrimination. Journal of Neurophysiology, 44, 440-455, 1980.
- Young, P. T. Influence of learning on taste preferences. Psychology Report, 19, 445-446, 1966.

**Temporal Analysis of Estradiol Blockage of Testosterone  
Effect on Conditioned Taste Aversions**

**David Yuan and Kathleen C. Chambers  
Department of Psychology  
University of Southern California  
Los Angeles, CA 90089-1061**

**Poster presented at the first annual meeting of the  
American Psychological Society  
Alexandria VA  
June 1989**

Adult male rats exhibit stronger resistance to extinction than adult female rats in the conditioned taste aversion (CTA) paradigm (Chambers & Sengstake, 1976). After males are gonadectomized their extinction rate is not different from that of intact females. Gonadectomized females show no change in extinction rate. When gonadectomized males are given testosterone (T) replacement, the rate of extinction is similar to that of intact males (Chambers, 1976). Thus T mediates the slower rate of CTA extinction observed in male rats.

Although T treatment is effective in slowing extinction in gonadectomized females it has a diminished effect in intact females (Chambers, 1976). When estradiol (E) and T are given to gonadectomized females the effectiveness of T in prolonging extinction also is reduced (Chambers, 1980). This suggests that E from the ovaries diminishes the effect of T on the rate of CTA extinction in intact females.

E could block the T-induced slow extinction rate by acting directly on a T-related mechanism or by acting independently of T. In order to understand the mechanism by which E blocks the effects of T, it is necessary to determine the following:

1. When during the CTA process does E act to block the T effect?
2. Does E have an effect on extinction when it is given alone?

#### EXPERIMENT 1

T acts to prolong extinction only if it is present during the extinction phase of the CTA (Chambers & Sengstake, 1979). It is not effective if it is present only during acquisition. If E acts on a T mechanism then E should be effective if it is present during extinction but not if it is present during acquisition. This experiment was designed to test whether E has the same time course of action as T.

#### METHOD

**Design.** 50 adult male rats were randomly assigned to one of the following five groups:

- |       |   |
|-------|---|
| O/O   | No hormone in both acquisition and extinction |
| ET/ET | E and T in both acquisition and extinction    |
| T/T   | T in both acquisition and extinction          |
| T/ET  | T in acquisition and E and T in extinction    |
| ET/T  | T and E in acquisition and T in extinction    |

**CTA Procedure.** All of the males were gonadectomized and hormones were administered through subcutaneously implanted silastic capsules. Nine days after surgery, the acquisition phase of the CTA procedure was initiated. All of the males were given a 9% chilled sucrose solution for one hr and then were injected ip with a 0.30 M LiCl solution (20cc/kg body weight). Two days later the acquisition phase hormone implants were replaced with the extinction phase implants. Nine days later the extinction phase was initiated. Starting on this day and continuing for the next 46 days, the males were given 9% sucrose solution for one hr.

### RESULTS

The five groups of males did not differ in the amount of sucrose consumed on the day of acquisition (Figure 1).

Figure 1

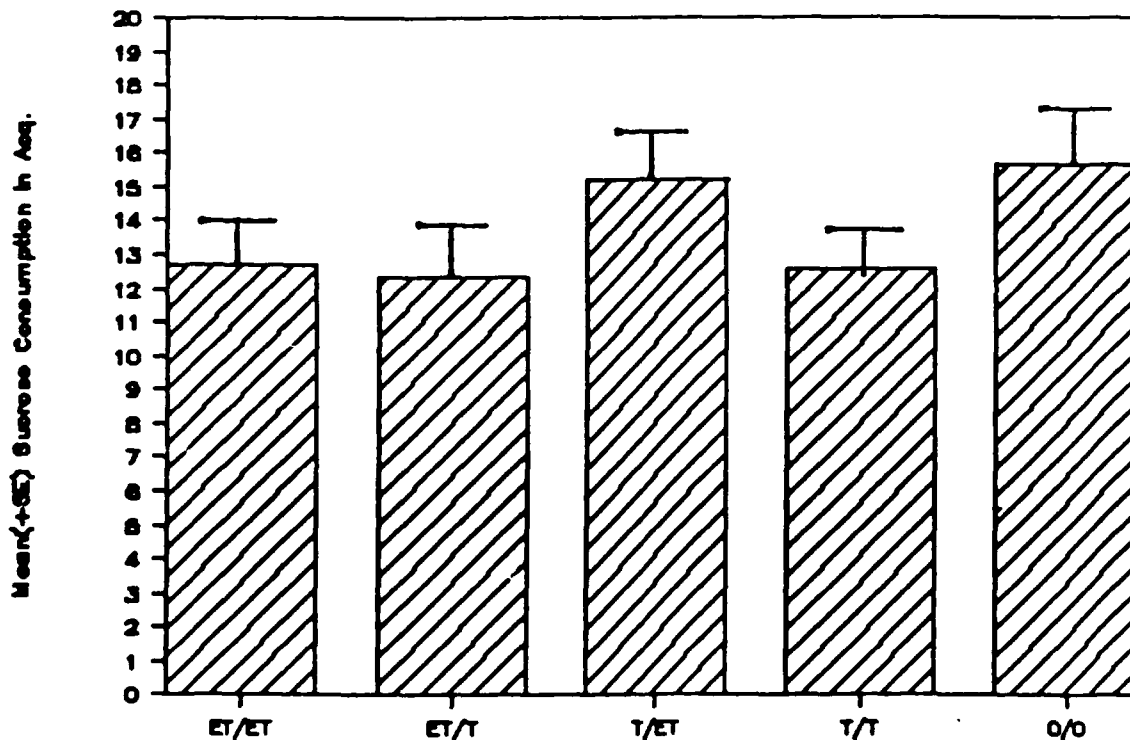

Extinction rates (the number of days to reach 100% of acquisition day consumption) were computed for each male. The extinction rates of the five groups differed significantly ( $F[4,44]=5.25, p=0.0015$ ). The Waller-Duncan K-ratio T test indicated that the 3 groups with estradiol (ET/T, T/ET and ET/ET) and the no hormone group (O/O) did not differ but these four groups extinguished faster than group T/T (Figure 2).

Figure 2

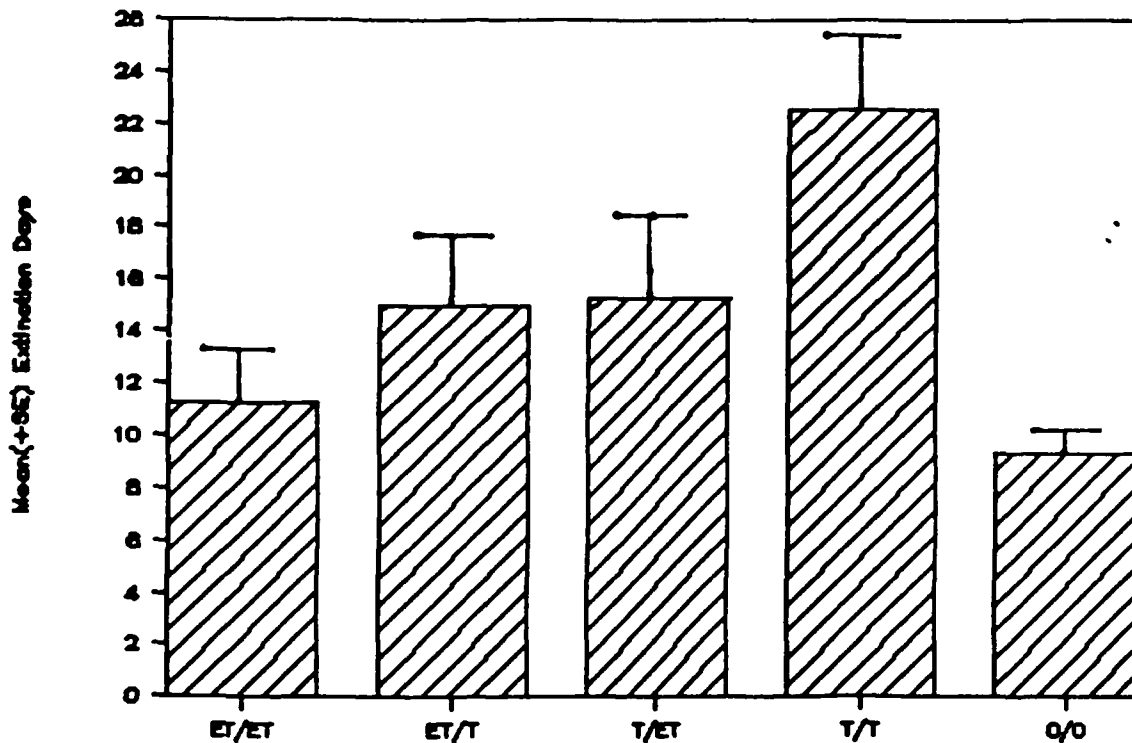

#### CONCLUSION

The results of this experiment show that E can act either during acquisition or extinction.

#### EXPERIMENT 2

Although we previously found that E itself had no significant effect on extinction in gonadectomized males and females, the number of animals tested was small and the extinction rates tended to be lower than those of gonadectomized controls (Chambers, 1980). Also, Earley and Leonard (1979) reported that when gonadectomized males were given one or two preconditioning exposures to the sucrose solution prior to CTA induction, E increased the extinction rate. The following study was designed to determine whether E increases the rate of extinction of a CTA.

#### METHOD

**Design.** 30 adult female rats were randomly assigned to one of the following groups:

- 0 No hormone in acquisition and extinction
- E-10 Low E dose in acquisition and extinction
- E-30 High E dose in acquisition and extinction

**CTA Procedure.** All of the females were gonadectomized and E was administered through subcutaneously implanted silastic capsules. Twelve days after surgery, the acquisition phase of the CTA procedure was initiated. All of the females were given a 9% chilled sucrose solution for one hr and then were injected ip with a 0.30 M LiCl solution (20cc/kg body weight). Two days later the extinction phase was initiated. Starting on this day and continuing for the next 20 days, the females were given 9% sucrose solution for one hr.

### RESULTS

The three groups of females did not differ in the amount of sucrose consumed on the day of acquisition (Figure 3).

Figure 3

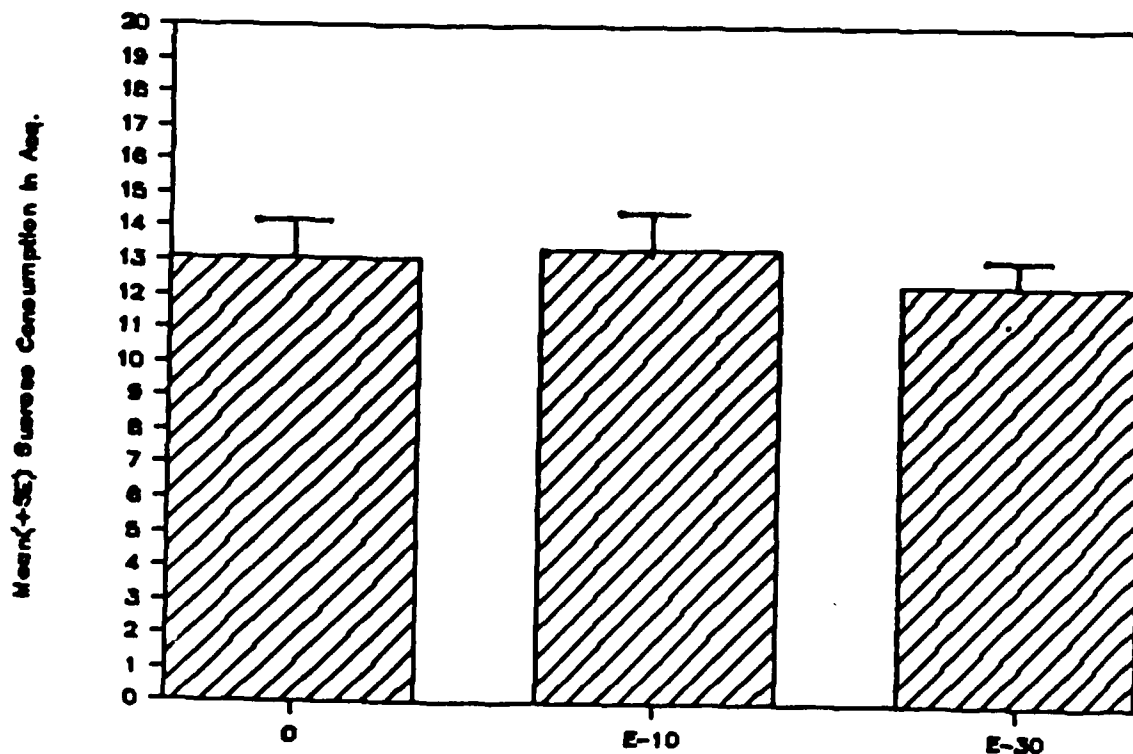

Extinction rates (the number of days to reach 100% of acquisition day consumption) were computed for each female. The extinction rates of each of the three groups differed significantly ( $F(2,27)=23.45, p<0.0001$ ; Waller-Duncan K-ratio T test; Figure 4).

Figure 4

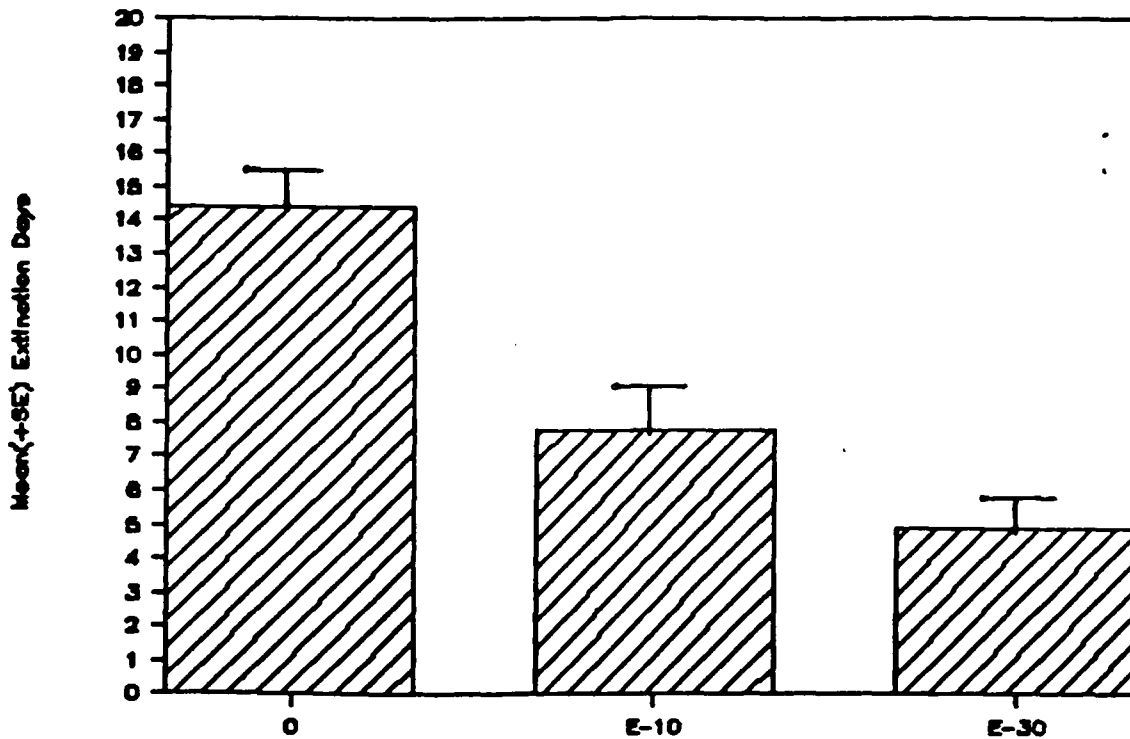

#### CONCLUSION

The results of this experiment show that E has an effect on CTA extinction when it is given alone.

#### GENERAL CONCLUSIONS

The results of these experiments suggest that E does not act on a T-related mechanism but rather acts independently of T.

Recently, Gustavson and Gustavson (1987) reported that E can be used as a toxin to induce a CTA. We suggest that the E blockage of the T-induced slow extinction can be explained in terms of its toxic effects.

Cannon, Berman, Baker and Atkinson (1975) have shown that presentation of one toxin that is not paired to a food before acquisition or extinction of a CTA induced by another toxin can attenuate the acquisition and extinction processes.

#### ACKNOWLEDGEMENT

This work was supported by Grant N00014-89-J-1296 from the Office of Naval Research and Grant HD20970 from the National Institutes of Health.



## REFERENCES

- Cannon, D. S., Berman, R. F., Baker, T. B. and Atkinson, C. A. Effect of preconditioning unconditioned stimulus experience on learned taste aversions. Journal of Experimental Psychology: Animal Behavior Processes, 104, 270-284, 1975.
- Chambers, K. C. Hormonal influences on sexual dimorphism in rate of extinction of a conditioned taste aversion. Journal of Comparative and Physiological Psychology, 90, 851-856, 1976.
- Chambers, K. C. Progesterone, estradiol, testosterone and dihydrotestosterone: Effects on rate of extinction of a conditioned taste aversion in rats. Physiology and Behavior, 24, 1061-1065, 1980.
- Chambers, K. C. and Sengstake, C. B. Sexually dimorphic extinction of a conditioned taste aversion in rats. Animal Learning & Behavior, 4, 181-185, 1976.
- Chambers, K. C. and Sengstake, C. B. Temporal aspects of the dependency of a dimorphic rate of extinction on testosterone. Physiology and Behavior, 22, 53-56, 1979.
- Earley C. J. and Leonard, B. E. Effects of prior exposure on conditioned taste aversion in the rat: Androgen- and estrogen-dependent events. Journal of Comparative and Physiological Psychology, 93, 793-805, 1979.
- Gustavson, C. R. and Gustavson, J. C. Estrogen induced anorexia in the rat: An LiCl comparison suggests it is estrogen induced nausea. Society for Neuroscience Abstracts, 13, 555, 1987.

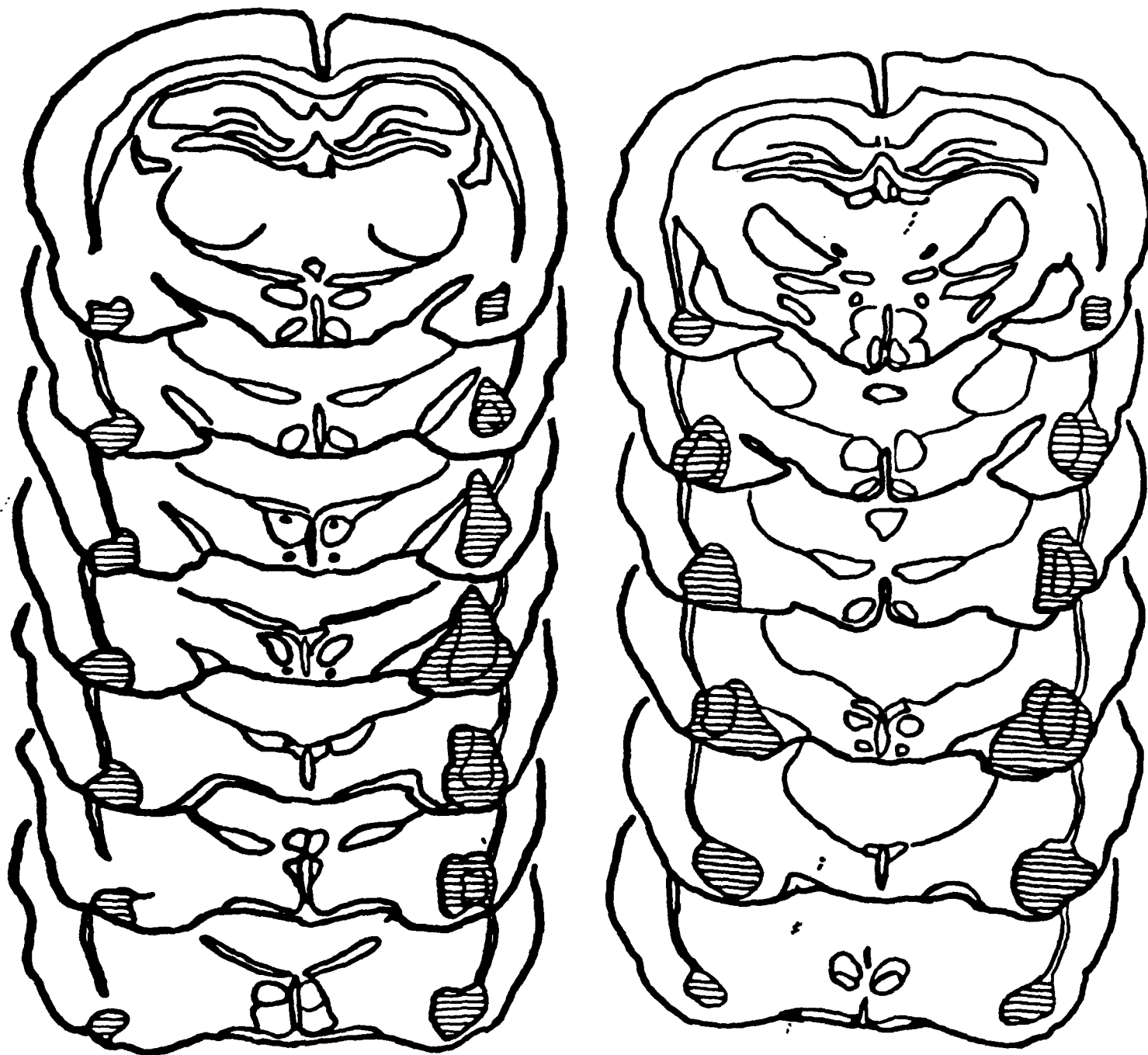

Figure 1. Schematic drawings of the smallest and largest electrolytic lesions of the amygdala. Sections were projected using a photographic enlarger and traced onto paper. Sections from the smallest lesion were taken every 0.2 mm. Sections from the largest lesion were taken every 0.4 mm.

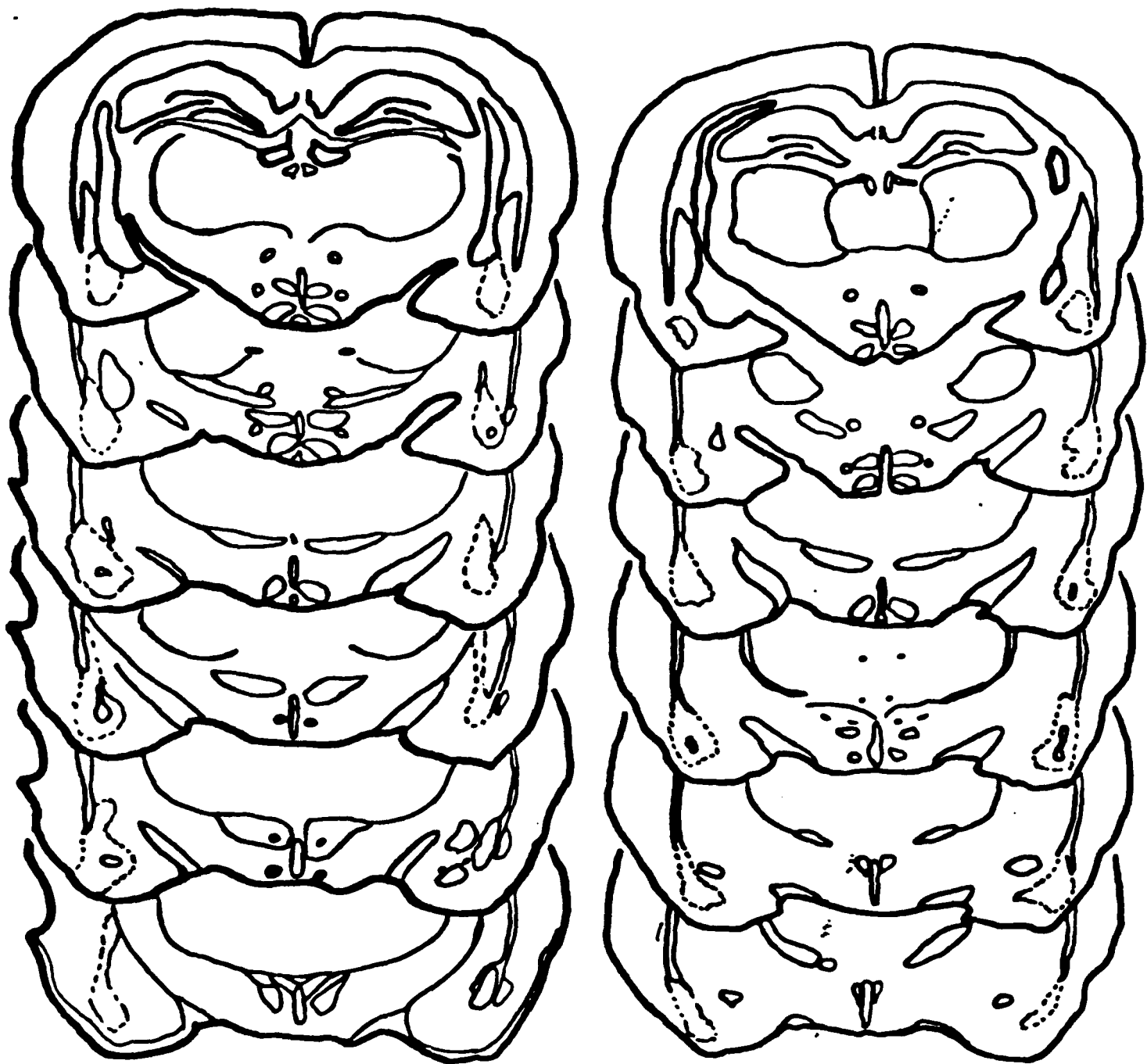

Figure 2. Schematic drawings of the smallest and largest neurotoxic (NMDA) lesions of the amygdala. Sections were projected using a photographic enlarger and traced onto paper. Sections from the smallest lesion were taken every 0.2 mm. Sections from the largest lesion were taken every 0.3 mm.

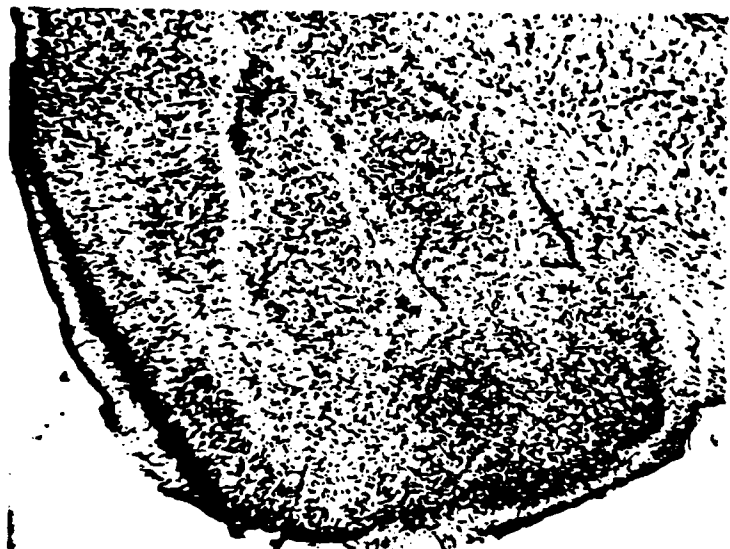
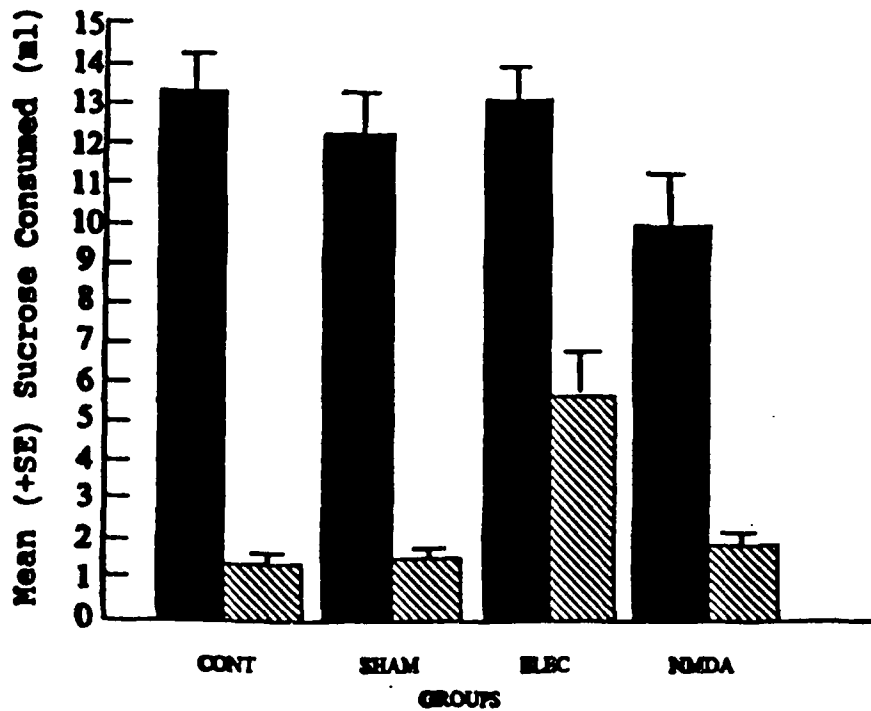
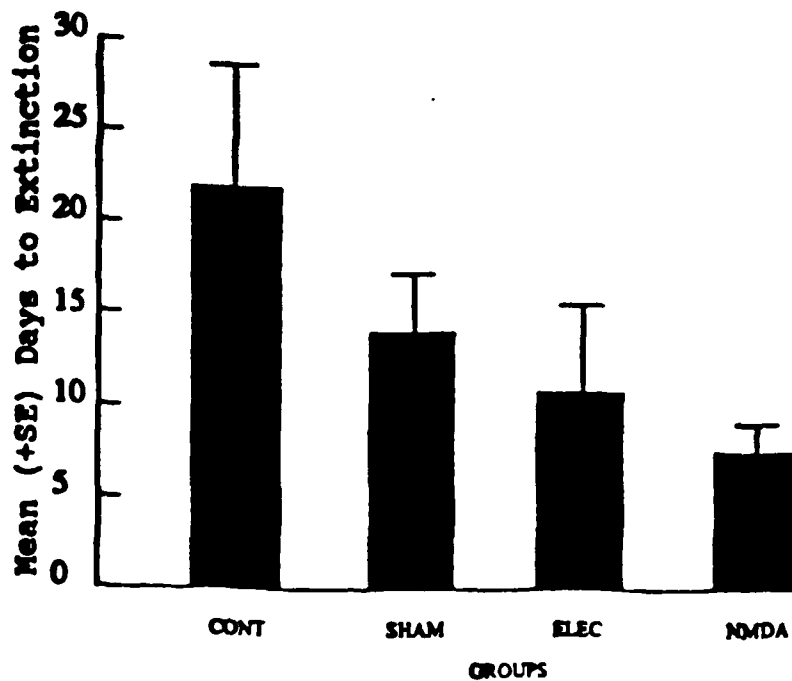

Figure 3. Photomicrographs of representative sections of control, sham, neurotoxic (NMDA) and electrolytic lesions in clockwise order starting top left.



Mean (+SE) sucrose consumed by control (CONT), sham, electrolytic lesioned (ELEC) & neurotoxic lesioned (NMDA) male rats on the day of acquisition (dark bars) and the first day after acquisition (hatched bars)



Mean (+SE) number of days control (CONT), sham, electrolytic lesioned (ELEC) & neurotoxic lesioned (NMDA) male rats drank within 1 ml of their acquisition day consumption

**A NEURAL MODEL FOR CONDITIONED TASTE AVERSIONS**

**Kathleen C. Chambers**

**Department of Psychology  
University of Southern California**

**Running Title: Taste Aversions**

**Address: Kathleen C. Chambers, Ph.D.  
Department of Psychology  
Seeley G. Mudd Building  
University of Southern California  
Los Angeles, CA 90089-1061**

**Phone: (213) 743-4393**

Neural Model for Acquisition of Conditioned Taste Aversions	1
Known Neural Circuitry for Conditioned Taste Aversions	8
The US Pathway	8
The CS Pathway	9
The US <sub>cs</sub> and CS <sub>cs</sub> Pathways	10
CS-US Integration	11
Conclusion	13
Retention	13
Extinction	14

From the time the parameters defining conditioned food aversions (CFAs, learned aversions to a food or fluid when consumption of that substance is followed by illness) were determined, this learning situation has fallen outside the main conceptualizations of the traditional forms of classical and instrumental learning (Garcia & Koelling 1966, Garcia et al 1966). The two main characteristics that distinguish CFAs from the traditional learning paradigms are learning after a long delay between the food stimulus and the illness (up to several hours) and strong and persistent learning after a single pairing of the food stimulus and illness. It is history, now, that these differences altered the theoretical framework of learning and memory. After the publication and acceptance of the seminal papers of Garcia (Garcia & Koelling 1966, Garcia et al 1955, 1966), there was a flurry of research on CFAs (Riley & Baril 1976). But as is apparently true of all things novel, habituation set in and interest in this area waned. Now with the growth of the field of behavioral neuroscience and the successful application of neurobiological techniques to the study of learning and memory, interest in this maverick of learning is again increasing.

#### **NEURAL MODEL FOR ACQUISITION OF CONDITIONED TASTE AVERSIONS**

The most significant progress in identifying and characterizing the neuronal substrates of learning and memory has been made for classically conditioned learning situations



e.g., autonomic conditioning of heart rate (Cohen 1982, Kapp et al 1982) and eye blink conditioning (Thompson 1986). In these situations a stimulus (unconditioned stimulus, US) which elicits a response (unconditioned response, UR) is paired with another stimulus (conditioned stimulus, CS) that does not elicit the UR. The two stimuli are paired so that they are contiguous in time and contingent and so that the CS can provide information about the US (Rescorla 1988). Learning is inferred when presentation of the CS produces a response similar to the UR. The determination of the neural substrates for this learning situation involves the identification of 4 pathways: the US, UR, CS, and CR pathways.

Although CFA learning is thought to be a form of classical conditioning, it does not fit within the four pathway model. The food stimulus has been identified as the CS, the illness as the US and the avoidance of the food as the CR. There is, however, no clearly identifiable UR; a CFA can occur without an overt UR (Garcia et al 1972). A three pathway conceptualization has been implicit in most discussions of the neural basis of CFAs. Discussions have focused on how the food stimulus and illness are integrated neurally to produce a new response to the food. But a detailed analysis of the learning situation for one form of CFA learning, conditioned taste aversion (CTA), suggests that this conceptualization is not adequate.

Perhaps the best insight into the kind of neural model that best fits the CTA learning situation has come from the work of Grill and Norgren (1978). Taste stimuli have been known to elicit behavioral responses prior to food absorption in addition to the well known physiological responses, salivation and increased insulin release (Fischer et al 1972, Pavlov 1902). The most preferred tastes, such as sweet, evoke increased consummatory responses and the least preferred tastes, such as bitter, evoke reduced consummatory responses and food spillage. More recently, Grill and Norgren (1978) have described more complex behavioral responses elicited by different novel taste stimuli in rats. The rats were fitted with an intraoral catheter and the tastes were delivered directly into the mouth. The animals exhibited essentially two different patterns of stereotyped mouth, tongue, head, paw and forearm movements which reflected hedonic responsiveness to taste. Preferred substances elicited a series of rhythmic mouth movements and alternations between tongue protrusions and tongue retractions which resulted in swallowing and paw licking (ingestive responses). Nonpreferred substances elicited mouth gaping with tongue retraction followed by long duration tongue protrusion and then tongue retraction and mouth closure. This sequence of responses was repeated several times, resulted in a reduction in swallowing, and was often followed by a sequence of fixed action patterns which included chin rubbing, head shaking, paw wiping, and forelimb flailing (aversive responses).

Other tastes elicited a mixture of these two different patterns.

When rats are poisoned after consuming a preferred sweet taste such as sucrose, their subsequent behavioral responses to sucrose resemble those exhibited after consumption of nonpreferred bitter tastes such as quinine. They exhibit decreases in consumption levels, spillage of food and stereotyped aversive responses (Berridge et al 1981, Garcia & Koelling 1966, Rozin 1967). Illness, then, alters the response elicited by taste.

In most classically conditioned situations, the response elicited by the CS is altered because of its association with the US. In some cases the CR resembles the UR quite closely. But, the CR generally does not become identical to the UR (Holland 1984, Rescorla 1988). The CR can lack the intensity and some of the response repertoire observed for the UR and can include some responses that are not part of the UR. In some cases the CR produced by a given CS is in the opposite direction from the UR, e.g., increases in activity and heart rate elicited by a shock US and decreases in activity and heart rate elicited by a tone CS (DeToldeo & Black 1966, Rescorla 1988). Holland (1984) has suggested that the CR is composed of two behavioral elements: one that is similar to or at least in some way appropriate to the US and one that is similar to and an enhancement of the response elicited by the CS prior to conditioning.

What distinguishes the CTA learning situation from many other forms of classical conditioning is that the CR is entirely part of the repertoire of elicited responses for the CS sensory modality, in this case, taste. Although the response is appropriate to the US in that illness often produces decreases in food consumption, the decrease in consumption in a CTA situation is not general as in the case of illness but is specific to the CS. The CR is not similar to or an enhancement of the response elicited by the CS prior to conditioning but is in the opposite direction from that response.

The repertoire of taste elicited responses, then, forms an essential part of the neural model for CTAs. The determination of the neural substrates for CTAs should involve the identification of four pathways (Figure 1): the US pathway, the CS pathway, the pathway for the elicited response to the CS prior to conditioning ( $UR_c$ , or unconditioned ingestive response, UIR), and the pathway for the elicited response to the CS after conditioning ( $CR_c$ , or unconditioned aversive response, UAR). Each taste is connected to both the ingestive and aversive patterns of responses. These connections are probably innate as hedonic reactions to taste have been observed in fetal and neonatal individuals (Pfaffman 1978, Steiner 1973, 1979).

The relative strengths of the two innate connections are dependent on the given taste. In the case of sucrose, the innate connection to the ingestive response is stronger than the innate connection to the aversive response. If exposure

to sucrose is followed by illness, the connection to the ingestive response system will weaken and the connection to the aversive response system will strengthen. It is most likely that the illness-induced changes involve two rather than one process. Grill and Berridge (1985) have suggested that palatability processing involves two mechanisms and have provided evidence that the ingestive and aversive response systems can change independently. Thus, in order for the aversive response system to be expressed solely, a weakening of the ingestive response system would have to occur. If exposure to sucrose is not followed by negative consequences, a stronger connection to the ingestive response system will result. A stronger connection to the ingestive response system also will occur if a given taste is associated with positive reinforcement or if it is followed by recuperation from illness (Garcia et al 1977, Revusky 1967, 1974, Young 1966). So, experiential factors can alter the strengths of the innate connections to the ingestive and aversive response patterns. Thus, after a given taste is experienced, the relative strengths of the ingestive and aversive response systems are a function of the original innate connections, the number of exposures to sucrose with illness and the number of exposures to sucrose without illness. This hypothesis is supported by the findings that CTAs to nonpreferred tastes are stronger than to preferred tastes (Etscorn 1973), repeated pairings of a taste with illness strengthens an aversion and repeated pairings of a taste without illness reduces the strength of an aversion (Kalat & Rozin 1973).

There are other factors associated with the CS and US that can influence the strength of an aversion and therefore must be taken into account when developing a neural model for CTAs. The strength of an aversion has been found to be a function of the intensity of the taste as measured by concentration (Dragoin 1971) and the amount consumed on the first exposure (Bond & DiGuisto 1975), the intensity of the US (Revusky 1968) and prior experience with the US (Cannon et al 1975).

There are several factors which can modulate the development and strength of CTAs, but are not essential or critical for aversion learning. The development and strength of an aversion is dependent on the hormonal milieu and deprivation state of the animal. The presence of testosterone (T) increases the proportion of animals that develop a CTA (Chambers et al 1981) and the presence of dexamethasone attenuates the strength of an aversion (Hennessy et al 1976). Water deprivation reduces the proportion of male rats that develop an aversion (Chambers et al 1981). It is interesting that deprivation can alter the hedonic value of tastes. Foods are reported to be more palatable with deprivation and less so with satiety (Cabanac 1971). Also, the number of ingestive responses decreases and the number of aversive responses increases as meal termination approaches (Grill & Berridge 1985). So, the relative strengths of the ingestive and aversive response systems are also a

function of modulating factors. A complete understanding of the neural mechanisms controlling CTAs would include a determination of the neural circuitry for the modulating factors (Figure 1).

#### **KNOWN NEURAL CIRCUITRY FOR CONDITIONED TASTE AVERSIONS**

##### The US Pathway

There have been a number of reviews of the US pathways (Ashe & Nachman 1980, Borison & Wang 1953, Coil & Garcia 1977, Kiefer 1985). The vagus nerve conveys information from the gastric-intestinal mucosa to the caudal region of the nucleus of the solitary tract (NST; Torvik 1956). It is then conveyed to the pontine parabrachial nucleus (PBN; Norgren 1978) and the insular cortex (Cechetto & Saper 1987). The area postrema, an area of the brain on the floor of the fourth ventricle that lacks a blood-brain barrier, detects chemicals in the blood. As there are reciprocal neural connections between the area postrema and the NST (Morest 1967), information about these blood-borne chemicals is probably conveyed to the NST.

A wide variety of substances can be used as the US. The route by which information about these substances is conveyed to the brain varies with the particular chemical and the route of administration. LiCl, a widely used illness-inducing agent, appears to act primarily by way of the area postrema. Lesions of the dorsolateral region of this area attenuate or abolish the learning of taste aversions induced

by LiCl (Ritter et al 1980), but, vagotomized rats develop essentially normal taste aversions (Martin et al 1978). The vagus nerve mediates copper sulfate induced aversions when this substance is administered intraperitoneally or intragastrically but when it is given intravenously the area postrema mediates the aversion (Coil & Norgren 1982, Coil et al 1978).

Although the vagus nerve and the area postrema are important routes for many different chemicals, they probably are not the only means by which information is conveyed to the brain. The area postrema is an important structure for the induction of emesis when apomorphine is administered but neither lesions of this area nor vagotomy has an affect on the ability of an animal to learn CTAs (Kiefer et al 1981, Van der Kooy et al 1983).

#### The CS Pathway

The CS for CFA learning involves stimuli that are normally used by a given species for the identification of food. For many species taste is the primary stimulus for identification. But it must be noted that other stimuli such as odor can serve as weak cues (Kiefer 1985) and some species use other senses as the primary stimulus, e.g., birds use vision (Gaston 1977).

The gustatory pathway has been reviewed recently by Norgren (1984) and Travers, Travers and Norgren (1987). In



summary, taste receptor cells are located primarily in the tongue and hard and soft palate. Taste information is transmitted primarily to three different peripheral taste nerves; the chorda tympani branch of the facial nerve, the lingual branch of the glossopharyngeal nerve, and the greater superficial petrosal branch of the facial nerve. Gustatory afferent fibers from the facial and glossopharyngeal nerves terminate in the ipsilateral NST. Ascending axons from the NST terminate in the ipsilateral PBN in rodents and lagomorphs and the ventroposteromedial nucleus of the thalamus in primates. The PBN sends projections ipsilaterally to the parvicellular division of the nucleus ventralis posteromedialis (VPMpc) and also projects extensively to the ventral forebrain, in particular, the lateral hypothalamus, central nucleus of the amygdala, and bed nucleus of the stria terminalis. The VPMpc projects to the insular cortex which projects back to the VPMpc, central amygdala, PBN and NST.

#### The US<sub>c</sub> and CS<sub>c</sub> Pathways

Neural areas rostral to the PBN are not critical for hedonic reactions to taste. Hedonic responsiveness remains in rats with supracollicular decerebrate preparations which leave only the first (NST) and second (PBN) central gustatory relay nuclei. Intraoral taste stimulation of these rats elicited the same ingestive and aversive patterns of taste responsiveness at the same concentrations as it did in intact rats (Grill & Berridge 1985).

There are neurons in the PBN that project to oro-motor nuclei (Travers & Norgren 1983) and that respond to both the hedonic dimensions of taste and oro-lingual movement (Schwartzbaum 1983). It seems likely that the ingestive and aversive behaviors are organized entirely in the brain stem and that the control of these behaviors involves the NST and PBN and their polysynaptic connections to the motor neuron pools controlling the behaviors. As the ingestive and aversive movements to taste stimuli are stereotyped, repetitive and rhythmic, the neural circuits for these behaviors may function as pattern generators with higher brain systems acting only as modulators. In this sense, the control of these behaviors may resemble that of vertebrate locomotion (Grillner 1985).

Since the behavioral response elicited by bitter tastes is similar to that elicited by a taste that has been paired with illness, one would expect that at least at the level of the behavioral pattern generators the neural code for the CS would be similar to that for quinine. Chang and Scott (1984) have found that the pattern of activity of sucrose-best NST neurons in response to saccharin changes after rats acquire an aversion to this taste so that it more closely resembles that of bitter tastes.

#### CS-US Integration

Possible sites of taste-illness integration have been

discussed in a number of recent reviews (Ashe & Nachman 1980, Gaston 1978, Grill 1985, Kiefer 1985). The search for such sites has been plagued by inconsistent findings and unequivocal candidates have not emerged. It is clear that the neural control of this primitive form of learning is complex, and, it is likely that there are a number of neural routes that can be used for laying down the trace. Despite the contradictory endeavors, there are some findings that have come out of the search which should provide more insight into the neural organization of CTAs.

One of the more consistent findings has been that lesions of the basolateral amygdala disrupt taste aversion learning and retention of an aversion learned prior to lesioning (Simbayi et al 1986, Nachman & Ashe 1974). But after finding that cutting the connections between the amygdala and the temporal cortex produced the same deficits as lesions of the basolateral amygdala, Fitzgerald and Burton (1983) suggested that it is the destruction of the fibers of passage that produces the deficits after lesions of the basolateral amygdala and not the destruction of the nucleus itself. Recently, Dunn and Everitt (1988) found that ibotenic induced lesions which spare the fibers of passage had no effect on aversion learning. Anna Brownson, Richard Thompson and I have confirmed and extended this finding in a preliminary study. Electrolytic lesions attenuated both the acquisition of an aversion and the retention of an aversion

induced prior to lesioning; NMDA-induced lesions which also spare the fibers of passage had no effect on either acquisition or retention (Figure 2). Clearly the issue of axons of passage is critical to an understanding of neural mechanisms.

Lesions of the PBN disrupt acquisition of a CTA when there is a delay between the CS and US (Schulkin et al 1986, DiLorenzo 1988). But if there is no delay, animals can learn an aversion (DiLorenzo 1988). Similar results have been found for lesions of the gustatory cortex (Lorden 1976). These findings suggest that there are different neural mechanisms for learning with short and long CS-US intervals and that any neural model must include both pathways.

## CONCLUSION

Although I have focused only on the acquisition process, a complete neural model of CTA should include retention and extinction processes as well. There probably are neural areas that are part of the pathways for all three processes, but the pathways are different. And, each process has its own set of modulating factors that influence that process independently of the other.

### Retention

Little is known about the neural mechanisms for CTA, but, the data that do exist suggest that the neural mechanisms for acquisition and retention differ. Although the gustatory neocortex is involved in acquisition, it is not essential for learning (Braun et al 1972, Lasiter & Glanzman 1982, Lorden 1976). It is, however, critically involved in retention of aversions as animals with these lesions do not retain a previously learned aversion (Braun et al 1981, Yamamoto et al 1981).

### Extinction

Extinction has been regarded merely as a reflection of the acquisition process. In many cases the strength of acquisition has been measured by the rate of extinction. If extinction was slow, acquisition was strong and if extinction was fast, acquisition was weak. But extinction, at least of a CTA, is far more complex than this. There is evidence that suggests that the neural processes mediating acquisition and extinction of a CTA are different. If animals are anesthetized or under cortical spreading depression when they are given exposure to a taste, they do not acquire a CTA but they do extinguish a previously learned aversion (Bures & Buresova 1977). The vagus nerve plays a role in extinction that is independent of its involvement during acquisition (Coil et al 1978, Kiefer et al 1981). Rats that are vagotomized prior to or after acquisition of a CTA exhibit a faster extinction than nonvagotomized animals even when a US (apomorphine) that is not vagally mediated is used. There

are a number of other factors which modulate extinction independently of acquisition. The rate of extinction is altered when ACTH levels are elevated, when T is present and when animals are under water deprivation (Chambers 1985, Chambers & Sengstake 1979, Kendler et al 1976, Sengstake & Chambers 1979). ACTH and T decrease and water deprivation increases the rate. It is the presence of these factors during extinction that alters the rate of extinction. Their presence or absence during acquisition of the aversion has no effect.

Extinction is a learning process (Rescorla, 1987). Simply stated for CTAs it is unlearning that the taste predicts illness and learning that it predicts safety. With respect to the neural model for CTAs outlined earlier, extinction is a process by which connections to the aversive response system are weakened and connections to the ingestive response system are strengthened. Any information on the subsequent consequences of ingesting the CS is processed. If the consequences are neutral, that information serves to alter the relative strengths of the two response systems. Thus, after a CS has been experienced without negative consequences, the relative strengths of the ingestive and aversive response systems are a function of the relative strengths of these systems after the CTA, the number of exposures to the taste without illness, modulating factors, and probably the original innate predisposition.

## ACKNOWLEDGMENT

This work was supported by Grant N0014-89-J-1296 from the Office of Naval Research and Grant HD20970 from the National Institutes of Health. The author thanks Richard F. Thompson for his helpful suggestions.

Literature Cited

- Ashe, J. H., Nachman, M. 1980. Neural mechanisms in taste aversion learning. Prog. Psychobiol. Physiol. Psych. 9:233-262
- Berridge, K., Grill, H. J., Norgren, R. 1981. Relation of consummatory responses and preabsorptive insulin release to palatability and learned taste aversions. J. Comp. Physiol. Psych. 95:363-382
- Bond, N., Di Giusto, E. 1975. Amount of solution drunk is a factor in the establishment of taste aversion. Anim. Learn. Behav. 3:81-84
- Borison, H. L., Wang, S. C. 1953. Physiology and pharmacology of vomiting. Pharm. Rev. 5:193-230
- Braun, J. J., Kiefer, S. W., Ouellet, J. V. 1981. Psychic ageusia in rats lacking gustatory neocortex. Exp. Neuro. 72:711-716
- Braun, J. J., Slick, T. B., Lorden, J. F. 1972. Involvement of gustatory neocortex in the learning of taste aversions. Physiol. Behav. 9:637-641
- Bures, J., Buresova, O. 1979. Neurophysiological analysis of conditioned taste aversion. In Brain Mechanisms in Memory and Learning: From the Single Neuron to Man, ed. M. A. Brazier, pp. 127-138. New York: Raven Press.



- Cabanac, M. 1971. Physiological role of pleasure. Science 176:1103-1107
- Cannon, D. S., Berman, R. F., Baker, T. B., Atkinson, C. A. 1975. Effect of preconditioning unconditioned stimulus experience on learned taste aversions. J. Exp. Psychol.: Anim. Behav. Proces. 104:270-284
- Cechetto, D. F., Saper, C. B. 1987. Evidence for a viscerotopic sensory representation in the cortex and thalamus in the rat. J. Comp. Neurol. 262:27-45
- Chambers, K. C. 1985. Sexual dimorphisms as an index of hormonal influences on conditioned food aversions. Ann. NY Acad. Sci. 443:110-125
- Chambers, K. C., Sengstake, C. B. 1979. Temporal aspects of the dependency of a dimorphic rate of extinction on testosterone. Physiol. Behav. 22:53-56
- Chambers, K. C., Sengstake, C. B., Yoder, R. L., Thornton, J. E. 1981. Sexually dimorphic acquisition of a conditioned taste aversion in rats: Effects of gonadectomy, testosterone replacement and water deprivation. Physiol. Behav. 27:83-88
- Chang, F-C. T., Scott, T. R. 1984. Conditioned taste aversions modify neural responses in the rat nucleus tractus solitarius. J. Neurosci. 4:1850-1862
- Cohen, D. H. 1982. In Conditioning: Representation of involved neural functions, ed. C. D. Woody, pp. 517-534. New York:

Plenum Press.

- Coil, J. D., Garcia, J. 1977. Conditioned taste aversions: The illness US. Paper presented at the Northeastern Regional Meeting of the Animal Behavior Society, October, 1977, Memorial University of Newfoundland, St. John's, Newfoundland, Canada.
- Coil, J. D., Norgren, R. 1982. Taste aversions conditioned with intravenous copper sulfate: Attenuation by ablation of the area postrema. Brain Res. 212:425-433
- Coil, J. D., Rogers, R. C., Garcia, J., Novin, D. 1978. Conditioned taste aversions: Vagal and circulatory mediation of the toxic unconditioned stimulus. Behav. Bio. 24:509-519
- DeToledo, L. & Black, A. H. 1966. Heart rate: Changes during conditioned suppression in rats. Science 152:1404-1406
- Di Lorenzo, P. M. 1988. Long-delay learning in rats with parabrachial pontine lesions. Chem. Senses 13:219-229
- Dragoin, W. B. 1971. Conditioning and extinction of taste aversions with variations in intensity of the CS and the UCS in two strains of rats. Psychon. Sci. 22:303-304
- Dunn, L. T., Everitt, B. J. 1988. Double dissociations of the effects of amygdala and insular cortex lesions on conditioned taste aversion, passive avoidance, and neophobia in the rat using the excitotoxin ibotenic acid. Behav. Neurosci. 102:3-23

- Estcorn, F. 1973. Effects of a preferred vs a nonpreferred CS in the establishment of a taste aversion. Physiol. Psych. 1:5-6
- Fischer, U., Hommel, H., Ziegler, M., Michael, R. 1972. The mechanism of insulin secretion after oral glucose administration: I. Multiphasic course of insulin mobilization after oral administration of glucose in conscious dogs. Differences to the behavior after intravenous administration. Diabetologia 8:104-110
- Fitzgerald, R. E., Burton, M. J. 1983. Neophobia and conditioned taste aversion deficits in the rat produced by undercutting temporal cortex. Physiol. Behav. 30:203-206
- Garcia, J., Ervin, F. R., Koelling, R. A. 1966. Learning with prolonged delay of reinforcement. Psychon. Sci. 5:121-122
- Garcia, J., Hankins, W. G., Coil, S. D. 1977. Koalas, men and other conditional gastronomes. In Food Aversion Learning, ed. N. W. Milgram, L. Krames, T. Alloway. New York: Plenum Press.
- Garica, J., Kimeldorf, D. J., Koelling R. A. 1955. Conditioned aversion to saccharin resulting from exposure to gamma radiation. Science 122:157-158
- Garcia, J., Koelling, R. A. 1966. Relation of cue to consequence in avoidance learning. Psychon. Sci. 4:123-124
- Garcia, J., McGowan, B. K., Green, K. 1972. Biological

- constraints on conditioning. In Classical Conditioning II: Current Research Theory, ed. A. H. Black, W. F. Prokasy. New York: Appleton-Century-Crofts.
- Gaston, K. 1977. An illness-induced conditioned aversion in domestic chicks: One-trial learning with a long delay of reinforcement. Behav. Biol. 20:441-445
- Gaston, K. 1978. Brain mechanisms of conditioned taste aversion learning: A review of the literature. Physiol. Psych. 6:340-353
- Grill, H. J. 1985. Introduction: Physiological mechanisms in conditioned taste aversions. Ann. NY Acad. Sci. 443:67-88
- Grill, H. J., Berridge, K. C. 1985. Taste reactivity as a measure of the neural control of palatability. Prog. Psychobiol. Physiol. Psych. 11:1-61
- Grill, H. J., Norgren R. 1978. The taste reactivity test. I. Mimetic responses to gustatory stimuli in neurologically normal rats. Brain Res. 143:263-279
- Grillner, S. 1985. Neurobiological bases of rhythmic motor acts in vertebrates. Am. Assoc. Advance. Science 228:143-149
- Hennessy, J. W., Smotherman, W. P., Levine, S. 1976. Conditioned taste aversion and the pituitary-adrenal system. Behav. Biol. 16:413-424
- Holland, P. C. 1984. The origins of Pavlovian conditioned behavior. In The Psychology of Learning and Motivation, ed.

- G. Bower, 18:129-173. Englewood Cliffs, N. J.: Prentice-Hall.
- Kalat, J. W., Rozin, P. 1973. "Learned safety" as a mechanism in long-delay taste-aversion learning in rats. J. Comp. Physiol. Psych. 83:198-207
- Kapp, B. S., Gallagher, M., Applegate, C. D., Frysinger, R. C. 1982. In Conditioning: Representation of involved neural functions, ed. C. D. Woody, pp. 581-600. New York: Plenum.
- Kendler, K., Hennessey, J. W., Smotherman, W. P., Levine, S. 1976. An ACTH effect on recovery from conditioned taste aversion. Behav. Biol. 17:225-229
- Kiefer, S. W. 1985. Neural mediation of conditioned food aversions. Ann. NY Acad. Sci. 443:100-109
- Kiefer, S. W., Rusiniak, K. W., Garcia, J., Coil, J. D. 1981. Vagotomy facilitates extinction of conditioned taste aversions in rats. J. Comp. Physiol. Psych. 95:114-122
- Lasiter, P. S., Glanzman, D. L. Cortical substrates of taste aversion learning: Dorsal prepiriform (insular) lesions disrupt taste aversion learning. J. Comp. Physiol. Psych. 96:376-392.
- Lorden, J. F. 1976. Effects of lesions of the gustatory neocortex on taste aversion learning in the rat. J. Comp. Physiol. Psych. 90:665-679

- Martin, J. R., Cheng, F. Y., Novin, D. 1978. Acquisition of learned taste aversion following bilateral subdiaphragmatic vagotomy in rats. Physiol. Behav. 21:13-17
- Morest, D. K. 1967. Experimental study of the projections of the nucleus of the tractus solitarius and the area postrema in the cat. J. Comp. Neurol. 130:277-300
- Nachman, M., Ashe, J. H. 1974. Effects of basolateral amygdala lesions on neophobia, learned taste aversions, and sodium appetite in rats. J. Comp. Physiol. Psychol. 87:622-643
- Norgren, R. 1978. Projections from the nucleus of the solitary tract in the rat. Neuroscience 3:207-218
- Norgren, R. 1984. Central neural mechanisms of taste. In Handbook of Physiology: A critical, comprehensive presentation of physiological knowledge and concepts. Section 1: The Nervous System. Vol. III. Sensory Processes. Part 2, ed. J. M. Brookhart, V. B. Mountcastle, I. Darian-Smith, S. R. Geiger, pp. 1087-1128. Bethesda: American Physiological Society.
- Pavlov, I. P. 1902. The Work of the Digestive Glands, trans. W. H. Thompson. London: Charles Griffin.
- Pfaffman, C. 1978. The vertebrate phylogeny, neural code, and integrative processes of taste. In Handbook of Perception, ed. E. C. Carterette, M. P. Friedman, VIA:51-123. New York: Academic Press.

- Rescorla, R. A. 1988. Pavlovian conditioning: It's not what you think it is. Am. Psychol. 43:151-160
- Rescorla, R. A. 1987. A Pavlovian analysis of goal-directed behavior. Am. Psychol. 42:119-129.
- Revusky, S. H. 1967. Hunger level during food consumption: Effects on subsequent preference. Psychon. Sci. 7:109-110
- Revusky, S. H. 1968. Aversion to sucrose produced by contingent X-irradiation: Temporal and dosage parameters. J. Comp. Physiol. Psych. 65:17-22
- Revusky, S. H. 1974. Retention of a learned increase in the preference for a flavored solution. Behav. Biol. 11:121-125
- Riley, A. L., Baril, L. L. 1976. Conditioned taste aversions: A bibliography. Anim. Learn. Behav. 4:1S-13S
- Ritter, S., McGlone, J. J., Kelley, K. W. 1980. Absence of lithium-induced taste aversion after area postrema lesion. Brain Res. 201:501-506
- Rozin, P. 1967. Specific aversions as a component of specific hungers. J. Comp. Physiol. Psych. 64:237-242
- Schulkin, J., Flynn, F. W., Grill, H. J., Norgren, R. 1986. Central gustatory lesions. II. Effects on salt appetite and taste aversion learning. Neurosci. Abstr. 15:1230
- Schwartzbaum, J. S. 1983. Electrophysiology of taste mediated

functions in parabrachial nuclei of behaving rabbit. Brain Res. Bull. 11:61-89

Sengstake, C. B., Chambers, K. C. 1979. Differential effects of fluid deprivation on the acquisition and extinction phases of a conditioned taste aversion. Bull. Psychon. Soc. 14:85-87

Simbayi, L. C., Boakes, R. A., Burton, M. J. 1986. Effects of basolateral amygdala lesions on taste aversions produced by lactose and lithium chloride in the rat. Behav. Neurosci. 100:455-465

Steiner, J. E. 1973. The gustofacial response: Observation on normal and anencephalic newborn infants. In Symposium on Oral Sensation and Perception, ed. J. F. Bosma. IV:254-278. Bethesda, Md.: NH-DHEW.

Steiner, J. E. 1979. Human facial expressions in response to taste and smell stimulation. In Advances in Child Development, ed. H. W. Reese, L. Lipsett, 13:257-295. New York: Academic Press.

Thompson, R. F. 1986. The neurobiology of learning and memory. Science 233:941-947

Torvik, A. 1956. Afferent connections to the sensory trigeminal nuclei, the nucleus of the solitary tract and adjacent structures: An experimental study of the rat. J. Comp. Neurol. 106:51-141



- Travers, J. B., Norgren, R. 1983. Afferent projections to the oral motor nuclei in the rat. J. Comp. Neurol. 220:280-298
- Travers, J. B., Travers, S. P., Norgren, R. 1987. Gustatory neural processing in the hindbrain. Ann. Rev. Neurosci. 10:595-632
- Van Der Kooy, D., Swerdlow, N. R., Koob, G. F. 1983. Paradoxical reinforcing properties of apomorphine: Effects of nucleus accumbens and area postrema lesions. Brain Res. 259:111-118
- Yamamoto, T., Azuma, S., Kawamura, Y. 1981. Significance of the cortical-amygdalar-hypothalamic connections in retention of conditioned taste aversion in rats. Exper. Neurol. 74:758-768
- Young, P. T. 1966. Influence of learning on taste preferences. Psycholog. Rep. 19:445-446

## Figure Captions

Figure 1. Simplified schematic of a neural model for traditional classical conditioning and conditioned taste aversion.

Abbreviations: CR, conditioned response;  $CR_{CS}$ , conditioned response to the CS; CS, conditioned stimulus; UAR, unconditioned aversive response; UIR, unconditioned ingestive response; UR, unconditioned response;  $UR_{CS}$ , unconditioned response to the CS; US unconditioned stimulus.

Figure 2. Mean (+SE) sucrose consumed by control (CONT), sham, electrolytic lesioned (ELEC) and NMDA lesioned male rats on the day of acquisition (ACQ; dark bars) and the first day after acquisition (hatched bars) when acquisition was given after and before amygdala lesions.

From: Chambers, K. C. A neural model for conditioned taste aversions. *Annual Review of Neuroscience*. In Press.  
**TRADITIONAL CLASSICAL CONDITIONING**

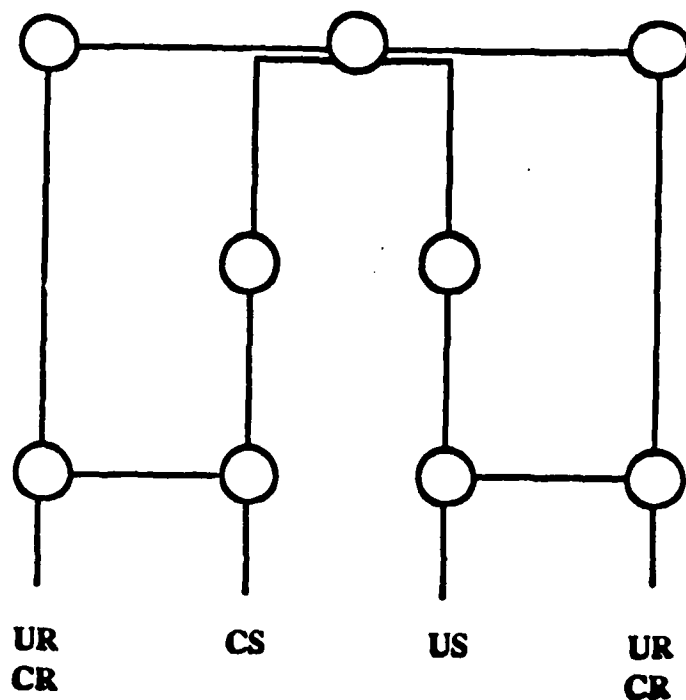

**CONDITIONED TASTE AVERSIONS**

