

2

File # 112 002

AD-A209 699

OFFICE OF NAVAL RESEARCH
Research Contract N00014-87-K-0014
R&T Code 413a001

Technical Report No. 19

A BOLT-ON DEPOSITION SOURCE FOR
ULTRA-HIGH-VACUUM GROWTH OF INTERMETALLIC COMPOUND FILMS

by

David K. Shuh, Young K. Kim and R. Stanley Williams

To be published
in
J. Vacuum Science & Technology



University of California, Los Angeles
Department of Chemistry & Biochemistry and Solid State Science Center
Los Angeles, CA 90024-1569

July 1, 1989

Reproduction in whole or part is permitted for any purpose of the United States Government.

This document has been approved for public release and sale;
its distribution is unlimited

89 6 21 023

UNCLASSIFIED

SECURITY CLASSIFICATION OF THIS PAGE

REPORT DOCUMENTATION PAGE				
1a REPORT SECURITY CLASSIFICATION UNCLASSIFIED		1b RESTRICTIVE MARKINGS N/A		
2a SECURITY CLASSIFICATION AUTHORITY N/A		3 DISTRIBUTION / AVAILABILITY OF REPORT Approved for public release; distribution unlimited		
2d DECLASSIFICATION / DOWNGRADING SCHEDULE N/A				
4 PERFORMING ORGANIZATION REPORT NUMBER(S) N/A		5 MONITORING ORGANIZATION REPORT NUMBER(S)		
6a NAME OF PERFORMING ORGANIZATION The Regents of the University of California		6b OFFICE SYMBOL (if applicable)	7a NAME OF MONITORING ORGANIZATION 1) ONR Pasadena - Administrative 2) ONR Alexandria - Technical	
6c ADDRESS (City, State, and ZIP Code) Office of Contracts & Grants Administration U C L A, 405 Hilgard Avenue Los Angeles, CA 90024		7b ADDRESS (City, State, and ZIP Code) 1) 1030 E. Green Street, Pasadena, CA 91106 2) 800 N. Quincy St., Arlington, VA 22217-5000		
8a NAME OF FUNDING / SPONSORING ORGANIZATION Office of Naval Research		8b OFFICE SYMBOL (if applicable) ONR	9 PROCUREMENT INSTRUMENT IDENTIFICATION NUMBER N00014-87-K-0014	
8c ADDRESS (City, State, and ZIP Code) 800 N. Quincy Street, 614A:DHP Arlington, VA 22217-5000		10 SOURCE OF FUNDING NUMBERS		
		PROGRAM ELEMENT NO	PROJECT NO	TASK NO
				WORK UNIT ACCESSION NO
11 TITLE (Include Security Classification) UNCLASSIFIED: Shop Note: A bolt-on deposition source for ultra-high-vacuum growth of intermetallic compound films				
12 PERSONAL AUTHOR(S) David K. Shuh, Young K. Kim and R. Stanley Williams				
13a TYPE OF REPORT Tech. Rept. #19		13b TIME COVERED FROM 1988 TO 1989	14 DATE OF REPORT (Year, Month, Day) 20 June 1989	15 PAGE COUNT 8
16 SUPPLEMENTARY NOTATION				
17 COSATI CODES			18 SUBJECT TERMS (Continue on reverse if necessary and identify by block number) thin film growth, transition metals, low vapor pressure, deposition pressure, material evaporation, stoichiometry control - single crystal epitaxy.	
FIELD	GROUP	SUB-GROUP		
19 ABSTRACT (Continue on reverse if necessary and identify by block number) An eight-inch ConFlat® flange assembly with both an electron-beam evaporator and a Knudsen cell has been constructed to deposit intermetallic compounds containing transition and group-III metals with specific phase composition. Initial depositions of thin films using this design have shown excellent epitaxy with the desired compound stoichiometry.				
20 DISTRIBUTION / AVAILABILITY OF ABSTRACT <input checked="" type="checkbox"/> UNCLASSIFIED/UNLIMITED <input type="checkbox"/> SAME AS RPT <input type="checkbox"/> DTIC USERS			21 ABSTRACT SECURITY CLASSIFICATION UNCLASSIFIED	
22a NAME OF RESPONSIBLE INDIVIDUAL R. Stanley Williams		22b TELEPHONE (Include Area Code) (213) 825-8818	22c OFFICE SYMBOL UCLA	

DD FORM 1473, 84 MAR

83 APR edition may be used until exhausted
All other editions are obsolete.

SECURITY CLASSIFICATION OF THIS PAGE

UNCLASSIFIED

**Shop Note: A Bolt-on Deposition Source For Ultra-High Vacuum
Growth of Intermetallic Compound Films**

David K. Shuh, Young K. Kim, and R. Stanley Williams

Department of Chemistry and Biochemistry

and Solid State Science Center, UCLA,

Los Angeles, CA 90024-1569 USA

An eight-inch ConFlat[®] flange assembly with both an electron beam evaporator and a Knudsen cell has been constructed to deposit intermetallic compounds containing transition and group III metals with specific phase composition. Initial depositions of thin films using this design have shown excellent epitaxy with the desired compound stoichiometry.

Thin film growth of many intermetallic compounds by molecular beam epitaxy (MBE) techniques is complicated by several factors: the low vapor pressure of transition metals, which requires the use of an electron beam evaporator, the need for precise control of the deposition fluxes to achieve the desired stoichiometry, and the physical constraints of ultra-high vacuum (UHV) chambers. An UHV compatible intermetallic film evaporator (IFE) was designed and fabricated to satisfy these requirements. The compact size of the IFE allows it to be integrated with existing UHV chambers that have an eight-inch ConFlat[®] flange with line-of-sight to the sample.

The basic design of the IFE employs a modified Thermionics Laboratories Inc. (TLI)¹ water-cooled, rod-fed 3 kW electron beam evaporator and a standard Knudsen cell source, both mounted on a single eight-inch UHV flange. The electron beam evaporator is used for vaporizing species with very high melting points, such as Co, and the Knudsen cell is for lower melting point species, such as Ga or In. The schematic of the IFE is shown in Figure 1. The evaporator utilizes high-purity metal rods of 3/16" diameter, which are available from several commercial suppliers, for evaporation stock, and can be used for several depositions before requiring a chamber vent. The evaporator was modified by replacing the flat boss used for the double sided evaporator seal with a fine-threaded

For	<input checked="" type="checkbox"/>
el	<input type="checkbox"/>
ed	<input type="checkbox"/>
tion	

on/	
-----	--

Availability Codes	
Dist	Avail and/or Special
A-1	



nut that improves sealing reliability and prevents twisting of the electrical feedthroughs on the evaporator head.

The port accommodating the Knudsen cell assembly is 1.6 inches from the centerline of the 8-inch flange and is set at 11° with respect to a perpendicular to the IFE flange face. The Knudsen cell is mounted on a custom designed 2.75-inch ConFlat[®] flange that has two mini-nipples; one for a rotary motion drive to operate a shutter and one for a four-pin electrical feedthrough for heater power and a thermocouple. The Knudsen cell assembly was constructed from two pressed BN crucibles.² The heat source is constructed of approximately 1 m of 0.25 mm Ta wire wrapped around a threaded 3 cc source crucible, which is snugly inserted into a larger crucible for thermal insulation. The resulting assembly is then heat shielded with Ta foil, mounted on two rods that are tapped into the flange face, and thoroughly degassed under vacuum before use with the IFE apparatus. Typical operating conditions to obtain a crucible temperature of 1000°C are 20 dc volts and 2 amps, with source flux stabilization within 20 minutes.

The integral liquid nitrogen cryoshroud fully encloses both evaporation sources and has a beam containment shield that prevents cross contamination of source materials. The shield also limits the forward and peripheral fields of view of the line-of-sight evaporators. This allows the IFE to operate in chambers that contain sensitive analytical optics. The two source shutters make

determination of both flux rates simple, since they isolate each source from a quartz crystal monitor that can be moved into the actual growth position. Alignment of the sources is straightforward since they share the same vertical focal plane and focal point (in our case the distance from the IFE flange face to the sample is 9.65 inches).

Operation of the IFE in a chamber designed for ultraviolet photoelectron spectroscopy (UPS) with a base pressure of 4×10^{-9} Torr yields typical deposition pressures of 1×10^{-7} Torr. Rates of material evaporation from the electron beam evaporator are variable and depend on material and applied power¹. Initial characterization of CoGa intermetallic films grown on GaAs(001) substrates with the IFE show excellent stoichiometry control and single crystal epitaxy³.

ACKNOWLEDGEMENTS

This work was supported by the State of California MICRO program and Hughes Aircraft. The authors wish to thank TLI for production of the IFE.

REFERENCES

1. Thermionics Laboratories Inc., P.O. Box 3711, Hayward, CA. 94540.
2. The R. D. Mathis Co., P.O. Box 6187, Long Beach, CA 90806.
3. Young K. Kim and R. Stanley Williams, to be published.

Figure 1. Schematic of the IFE apparatus and flange layout.

- A) Custom 2.75-inch flange for Knudsen cell
- B) Standard eight-inch ConFlat[®] flange
- C) Knudsen cell source shutter
- D) Beam containment shield
- E) Electron beam evaporator shutter
- F) Electron beam evaporator head assembly
- G) Cryoshroud
- H) Rotary feedthrough
- I) Double sealing flange assembly
- J) Water cooling lines for electron beam heater
- K) Knudsen cell electrical feedthroughs
- L) Cryoshroud coolant feedthroughs
- M) Electron beam evaporator electrical feedthrough
- N) Knudsen cell 2.75-inch port
- O) Electron beam evaporator assembly mounted on a 2.75-inch port

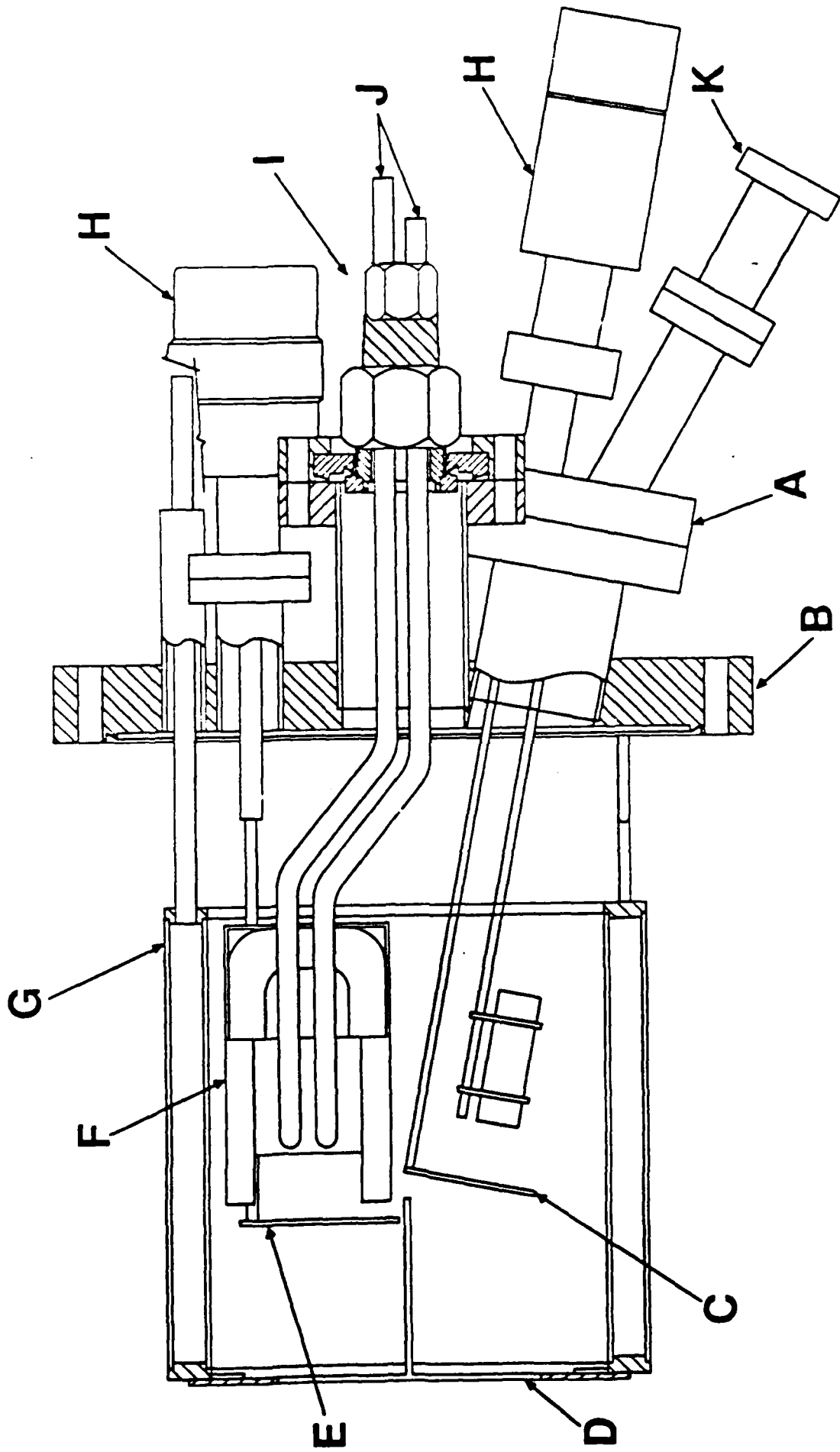

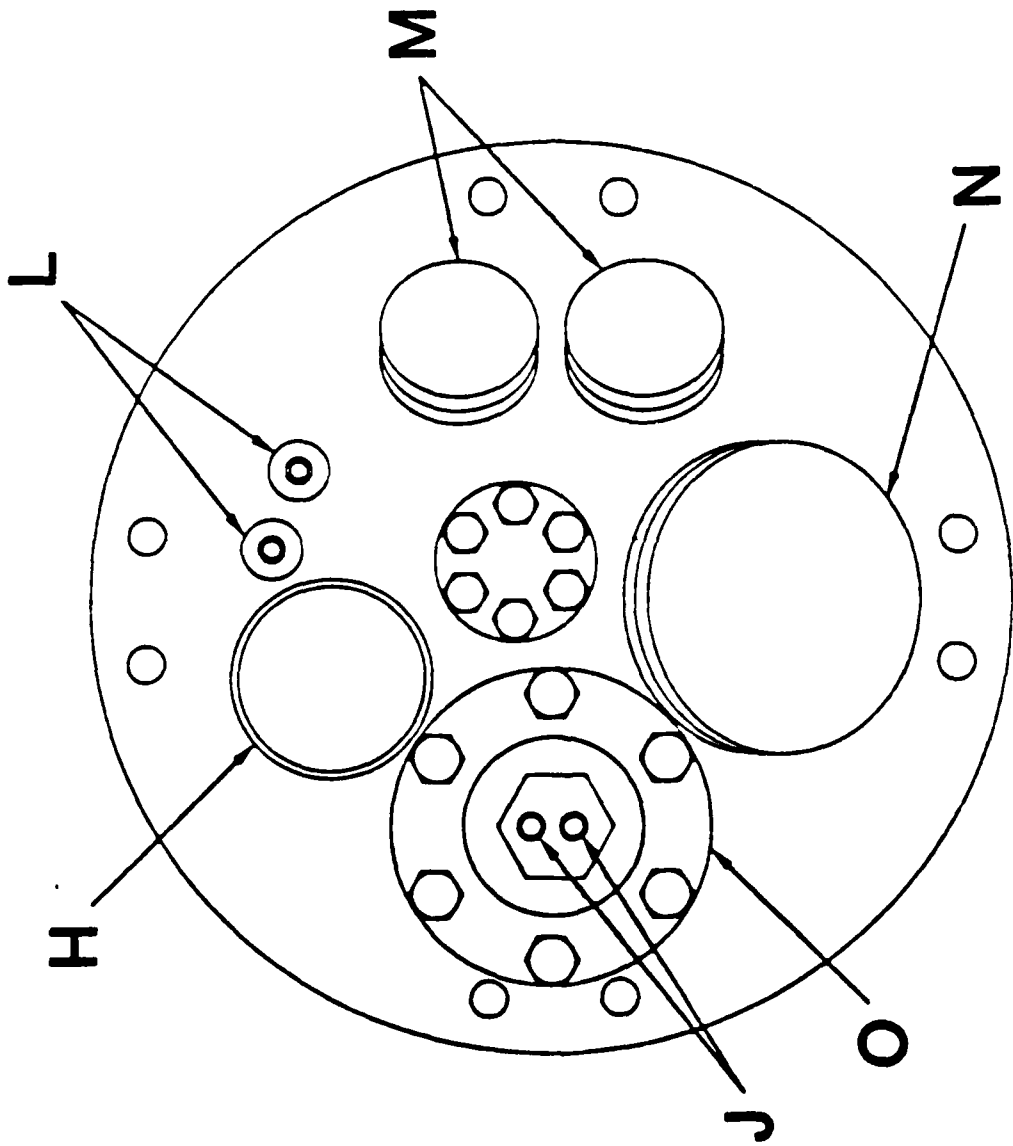

ABSTRACTS DISTRIBUTION LIST, SOLID STATE & SURFACE CHEMISTRY

TECHNICAL REFERENCE DISSEMINATION LIST, GENERAL

- Dr. J. Badeschwieler
Chemistry & Chem. Engrg.
Calif Inst of Technology
Pasadena, CA 91125
- Dr. Paul G. Barbara
Department of Chemistry
University of Minnesota
Minneapolis, MN 55455-0431
- Dr. Duncan W. Brown
Adv. Technology Mats., Inc.
520-B Danbury Road
New Milford, CT 06776
- Dr. S. Brochenstein
Department of Chemistry
State University of NY
Buffalo, NY 14214
- Dr. J. Butler
Naval Research Laboratory
Code 6115
Washington, DC 20375-5000
- Dr. R. P. H. Chang
Mats. Science & Engineering
Northwestern University
Evanston, IL 60208
- Dr. Paul A. Christman
Adv. Chem. Technol., Fed. Systems
Eastman Kodak Company
Rochester, NY 14650-2156
- Dr. Richard Colton
Code 6170
Naval Research Laboratory
Washington, DC 20375-5000
- Dr. J. E. Demuth
IBM Watson Research Center
PO Box 218
Yorktown Heights, NY 10598
- Dr. F. J. DiSalvo
Department of Chemistry
Cornell University
Ithaca, NY 14853
- Dr. A. B. Ellis
Department of Chemistry
University of Wisconsin
Madison, WI 53706
- Dr. M. A. El-Sayed
Chemistry Department
University of California
Los Angeles, 90024-1569
- Dr. John Eyster
Department of Chemistry
University of Florida
Gainesville, FL 32611
- Dr. James F. Garvey
Department of Chemistry
State University of New York
Buffalo, NY 14214
- Dr. T. F. George
Chemistry/Physics Dept.
State University of New York
Buffalo, NY 14260
- Dr. Arnold Green
Quantum Surface Dynamics Br.
Naval Weapons Ctr. Code 3817
China Lake, CA 93555
- Dr. R. Hamers
IBM Watson Research Center
PO Box 218
Yorktown Heights, NY 10598
- Dr. Paul K. Hansma
Department of Physics
University of California
Santa Barbara, CA 93106
- Dr. C. B. Harris
Chemistry Dept.
University of California
Berkeley, CA 94720
- Dr. J. C. Hemminger
Chemistry Dept.
University of California
Irvine, CA 92717
- Dr. Roald Hoffmann
Chemistry Dept.
Cornell University
Ithaca, NY 14853
- Dr. L. Inerarte
Chemistry Dept.
Rensselaer Polytech. Inst.
Troy, NY 12181
- Dr. E. A. Irene
Chemistry Dept.
Univ. of North Carolina
Chapel Hill, NC 27514
- Dr. D. E. Irish
Department of Chemistry
University of Waterloo
ONT N2L 3G1, Canada
- Dr. Mark Johnson
Department of Chemistry
Yale University
New Haven, CT 06511
- Dr. Sylvia M. Johnson
SRI International
333 Ravenswood Avenue
Menlo Park, CA 94025
- Dr. Z. H. Kafafi
Optical Sci. Div., Code 6551
Naval Research Laboratory
Washington, DC 20375-5000
- Dr. George H. Morrison
Chemistry Dept.
Cornell University
Ithaca, NY 14853
- Dr. Daniel M. Neumark
Chemistry Department
University of California
Berkeley, CA 94720
- Dr. D. Ramaker
Chemistry Dept.
George Washington Univ.
Washington, DC 20052
- Dr. R. Reeves
Chemistry Dept.
Rensselaer Polytech Inst.
Troy, NY 12181
- Dr. A. Reisman
Microelectronics Center
Research Triangle Park
No. Carolina, 27709
- Dr. G. Ruboff
IBM Watson Research Ctr.
PO Box 218
Yorktown Hgts, NY 10598
- Dr. Richard J. Saykally
Chemistry Department
University of California
Berkeley, CA 94720
- Dr. Robert W. Shaw
US Army Research Office
Box 12211
Res. Triangle Park, NC 27709
- Dr. S. Sibener
James Franck Institute
University of Chicago
Chicago, IL 60637
- Dr. R. E. Smalley
Department of Chemistry
Rice University, Box 1892
Houston, TX 77251
- Dr. G. A. Somorjai
Chemistry Dept.
University of California
Berkeley, CA 94720
- Dr. G. B. Stringfellow
Mats. Science & Engineering
University of Utah
Salt Lake City, UT 84112
- Dr. Galen D. Stucky
Chemistry Dept.
University of California
Santa Barbara, CA 93106
- Dr. H. Teichkawa
Chemistry Dept.
Jackson State University
Jackson, MI 39217
- Dr. W. Uenell
Surface Science & Technol Lab
University of Maine
Orono, ME 04469
- Dr. R. P. Van Duyne
Chemistry Dept.
Northwestern University
Evanston, IL 60201
- Dr. David M. Walba
Chemistry Department
University of Colorado
Boulder, CO 80309-0215
- Dr. J. H. Weaver
Chemical Engrg & Mats Sci.
University of Minnesota
Minneapolis, MN 55455
- Dr. B. R. Weiner
Department of Chemistry
University of Puerto Rico
Rio Piedras, PR 00931
- Dr. Robert L. Whetten
Chemistry Department
University of California
Los Angeles, CA 90024
- Dr. R. Stanley Williams
Dept. of Chemistry
University of California
Los Angeles, CA 90024
- Office of Naval Research
Chemistry Div., Code 1113
800 N. Quincy Avenue
Arlington, VA 22217-5000
- Chief of Naval Research
Spec. Assistant, Marine Corps
Code 818MC
800 N. Quincy Street
Arlington, VA 22217-5000
- Commanding Officer
Naval Weapons Support Center
Attn: Dr. Bernard E. Dousta
Ctane, IN 47522-5050
- Dr. Richard W. Drisko
Naval Civil Engineering Lab
Code 1-52
Port Hueneme, CA 93043
- Defense Tech. Information Ctr
Building 5
Cameron Station
Alexandria, VA 22314
- David Taylor Research Center
Attn: Dr. Eugene C. Fischer
Applied Chemistry Division
Annapolis, MD 21402-5067
- Dr. James S. Munday
Chemistry Div., Code 6100
Naval Research Laboratory
Washington, DC 20375-5000
- Dr. David Nelson
Office of Naval Res. Code 413
800 N. Quincy Street
Arlington, VA 22217-5000
- Dr. Ronald L. Atkins
Chemistry Div., Code 385
Naval Weapons Center
China Lake, CA 93555-6001
- Dr. Bernadette Eichinger
Naval Ships Systems Engr. Station
Phila. Naval Base, Code 053
Philadelphia, PA 19112
- David Taylor Research Station
Attn: Dr. H. H. Singerman
Code 283
Annapolis, MD 21402-5067
- Dr. Sachio Yamamoto
Naval Ocean Systems Center
Code 52
San Diego, CA 91232
- Carlene Laufmy
Office of Naval Research
1030 E. Green Street
Pasadena, CA 91106