

HDL-TM-89-5

May 1989

AD-A209 187

HEMP Validation of FAA Radio Facility

by Stephen C. Sanders

SDTICD  
ELECTE  
JUN 16 1989  
QH

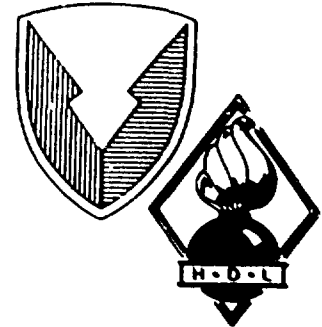

U.S. Army Laboratory Command  
Harry Diamond Laboratories  
Adelphi, MD 20783-1197

Approved for public release; distribution unlimited

89 6 16 3 15

The findings in this report are not to be construed as an official Department of the Army position unless so designated by other authorized documents.

Citation of manufacturers' or trade names does not constitute an official endorsement or approval of the use thereof.

Destroy this report when it is no longer needed. Do not return it to the originator.

UNCLASSIFIED

SECURITY CLASSIFICATION OF THIS PAGE

REPORT DOCUMENTATION PAGE				Form Approved OMB No. 0704-0188	
1a. REPORT SECURITY CLASSIFICATION UNCLASSIFIED		1b. RESTRICTIVE MARKINGS			
2a. SECURITY CLASSIFICATION AUTHORITY		3. DISTRIBUTION / AVAILABILITY OF REPORT Approved for public release; distribution unlimited			
2b. DECLASSIFICATION / DOWNGRADING SCHEDULE					
4. PERFORMING ORGANIZATION REPORT NUMBER(S) HDL-TM-89-5		5. MONITORING ORGANIZATION REPORT NUMBER(S)			
6a. NAME OF PERFORMING ORGANIZATION Harry Diamond Laboratories	6b. OFFICE SYMBOL (If applicable) SLCHD-NW-EH	7a. NAME OF MONITORING ORGANIZATION			
6c. ADDRESS (City, State, and ZIP Code) 2800 Powder Mill Road Adelphi, MD 20783-1197		7b. ADDRESS (City, State, and ZIP Code)			
8a. NAME OF FUNDING / SPONSORING ORGANIZATION Federal Aviation Administration	8b. OFFICE SYMBOL (If applicable)	9. PROCUREMENT INSTRUMENT IDENTIFICATION NUMBER			
8c. ADDRESS (City, State, and ZIP Code) APM-540 (Petteway) 800 Independence Avenue SW Washington, DC 20591		10. SOURCE OF FUNDING NUMBERS			
		PROGRAM ELEMENT NO.	PROJECT NO.	TASK NO.	WORK UNIT ACCESSION NO.
11. TITLE (Include Security Classification) HEMP Validation of FAA Radio Facility					
12. PERSONAL AUTHOR(S) Stephen C. Sanders					
13a. TYPE OF REPORT Final	13b. TIME COVERED FROM 4/87 TO 5/87	14. DATE OF REPORT (Year, Month, Day) May 1989		15. PAGE COUNT 27	
16. SUPPLEMENTARY NOTATION HDL project: E247E4; AMS 612120.H250000					
17. COSATI CODES			18. SUBJECT TERMS (Continue on reverse if necessary and identify by block number)		
FIELD	GROUP	SUB-GROUP			
18	06		Shield enclosure; HEMP test; lightning test; hf radio.		
19. ABSTRACT (Continue on reverse if necessary and identify by block number)					
The Harry Diamond Laboratories (HDL) provided high-altitude electromagnetic pulse (HEMP) and partial lightning hardness verification testing to a high-frequency radio facility for the Federal Aviation Administration (FAA), under the Department of Transportation (DOT). The facility consisted of a shielded enclosure with antennas and cables connected through protective devices at the shield to dummy loads within the shield. It was exposed to low-level radiation with measurements of internal fields extrapolated to threat levels and compared to specific criteria. Each typical penetration was injected with a simulated lightning source, and internal measurements were compared to specified criteria. Although criteria were not always met, it was judged with confidence that the facility would protect radio equipment. It was noted that the ac power spark gap would remain shorted until ac power shut down, resulting in system upset.					
20. DISTRIBUTION / AVAILABILITY OF ABSTRACT <input checked="" type="checkbox"/> UNCLASSIFIED/UNLIMITED <input type="checkbox"/> SAME AS RPT <input type="checkbox"/> DTIC USERS			21. ABSTRACT SECURITY CLASSIFICATION UNCLASSIFIED		
22a. NAME OF RESPONSIBLE INDIVIDUAL Stephen C. Sanders			22b. TELEPHONE (Include Area Code) (703) 490-2423	22c. OFFICE SYMBOL SLCHD-NW-EH	

DD Form 1473, JUN 86

Previous editions are obsolete.

SECURITY CLASSIFICATION OF THIS PAGE

UNCLASSIFIED

## Contents

	<u>Page</u>
1. Introduction.....	5
1.1 Program.....	5
1.2 Objectives and Criteria.....	5
1.3 Site Description.....	5
1.4 Threat Description.....	5
1.5 Test Facilities.....	6
2. HEMP Radiation Tests.....	7
2.1 Test Setup.....	7
2.2 Test Procedure for Pulsed E-Field Measurements.....	7
2.3 Test Procedure for cw E-Field Measurements (MIL-STD-285).....	7
2.4 Test Procedure for Coupled Responses.....	8
2.5 Test Procedure for Injection Responses.....	8
3. Test Data Reduction.....	9
3.1 Electrical Field.....	9
3.2 cw Field.....	10
3.3 ac Power Lines.....	11
3.4 ac Power Neutral Line.....	12
3.5 ac Power Auxiliary Line.....	13
3.6 ac Power Coupler.....	14
3.7 Digital Signal Lines.....	15
3.8 Audio Signal Lines.....	16
3.9 Telephone Lines.....	17
3.10 Teletype Lines.....	18
3.11 Transmitter Lines.....	19
3.12 Receiver rf Lines.....	20
4. Conclusions.....	21
Distribution.....	23

## Figures

1. Radiated HEMP test configuration and test points.....	7
2. Electric field data.....	9
3. Response of HFRF to cw field.....	10
4. Response of ac power source lines.....	11
5. Response of ac power neutral lines.....	12

6. Response of ac power auxiliary lines.....	13
7. Response of ac power coupler lines.....	14
8. Response of digital signal lines.....	15
9. Response of audio signal lines.....	16
10. Response of telephone signal lines.....	17
11. Response to teletype signal lines.....	18
12. Response of transmitter lines.....	19
13. Response of receiver rf lines.....	20

**Tables**

1. HEMP penetration points.....	5
2. EMP and lightning parameters.....	6
3. Instrumentation characteristics.....	6
4. Test point description.....	7
5. HFRF HEMP/lightning test measurement points.....	21

<b>Accession For</b>	
NTIS GRA&I	<input checked="" type="checkbox"/>
DTIC TAB	<input type="checkbox"/>
Unannounced	<input type="checkbox"/>
Justification	
By _____	
Distribution/ _____	
<b>Availability Codes</b>	
<b>Dist</b>	Avail and/or Special
A-1	



# 1. INTRODUCTION

## 1.1 Program

The Federal Aviation Administration (FAA) is preparing a high-frequency radio facility (HFRF) that is resistant to both high-altitude electromagnetic pulse (HEMP) and normal lightning to communicate between air traffic and controllers. This HFRF has a shielded enclosure which was tested for its ability to provide protection from the effects of HEMP and lightning. This test report describes the tests performed on the HFRF by the Systems Management American Corporation (SMA) and Harry Diamond Laboratories (HDL).

## 1.2 Objectives and Criteria

The primary objective of the testing was to verify beyond reasonable doubt that the equipment within the HFRF will be able to perform its mission after a HEMP or a normal lightning event with no loss of communications links or situation data. A secondary objective was to substantiate threat responses and establish a high level of confidence in the validity of the test. As part of these objectives, hardening devices were tested to establish their performance margins. The HEMP threat criterion is provided by the quadripartite standard treaty agreement group document, QSTAG-620, supplemented with an injection criterion to simulate the coupled responses of long cables; simulation is necessary because it is impractical to duplicate the threat environment over long distances. The lightning criterion, provided by the FAA, is tested by current injection to demonstrate that the equipment would survive most lightning strokes. The shield-room criterion calls for 60 dB of attenuation over the frequency range from 10 kHz to 1 GHz. Penetrations of this shield must meet a

transient limiting criterion of 100 V, 10 A, except for the ac power (110/220 V), specified as 1 kV, 10 A, and the two rf coaxial penetrators, specified as 10 kV, 500 A.

## 1.3 Site Description

The facility tested consisted of a transportable shielded room assembled at the Repetitive EMP Simulator (REPS) site at HDL's Woodbridge Research Facility. The shielded room was penetrated by ac and dc power lines, control lines, telephone lines, and rf lines elevated parallel to the simulator. All lines were shielded except the ac power lines. The room was designed to contain rack-mounted hf radio equipment, amplitude modulated, single sideband, receiving or transmitting over the frequency range of 2 to 29.999 MHz. The rf lines were terminated in the tuner circuitry in the shelter and with a 35-ft dipole at the far end. Other lines were terminated at both ends with resistors. Table 1 lists the circuits of interest for HEMP evaluation.

## 1.4 Threat Description

A high-altitude nuclear explosion generates a large amount of electromagnetic energy in the ionosphere which radiates about 1 J/m<sup>2</sup> over hundreds of thousands of square miles of the earth's surface. This energy can couple into metallic loops or lengths which can then conduct through an electrical unit's interface to devices which may be unable to withstand the stress. Loss of logic or operating characteristics may result. Some thresholds of damage are as follows:

relays	1 to 10 J
transistors	1 to 100 mJ
integrated circuits	10 to 1000 μJ

Table 1. HEMP penetration points

Function	Penetrations	Maximum cable length (ft)	Cable type	Protection	Load
ac power	2 sets, 3 wire	300	Unshielded	400-V spark	4.7 Ω
Audio	39 pair, 2 wire	300	Shielded	12-V Zener	650 Ω
Digital	4 pair, 2 wire	300	Shielded	12-V Zener	120 Ω
Phones	2 sets, 4 wire	300	Shielded	100-V Zener	650 Ω
rf line	2 sets, coax	270	Coaxial	2000-V spark	Complex*
Receive lines	1 line, coax	150	Unshielded	250-V spark	50 Ω

\*16-MHz tuned circuit

A thunderhead builds an electrical charge until a "streamer" of charge advances along a path of dielectric breakdown, or ionization, while an opposite streamer of charge rises from the earth to meet it. When they join, a current (of from 3 to 100 kA) drains the charge. As the charge depletes, other nearby charges resupply it for followup currents, or strokes. These strokes prefer conductors as a target and are destructive to exposed electrical equipment. Table 2 describes various lightning threats as a function of probability.

Protection from both threats requires that the transient energy be isolated from the equipment, usually by being diverted to an earth ground. These tests verify that the protection works.

### 1.5 Test Facilities

A current injector of 20 kV, 200 J of energy and a source impedance of 6  $\Omega$  was used to simulate lightning on the cables. This injector consists of a bank of capacitors charged until a spark gap pressurized with sulfur hexafluoride (SF<sub>6</sub>) arcs, at which time the charge flows through a pulse-

shaping network to the circuit under test, returning to the injector through facility ground. HDL's REPS, which can radiate a low-level composite HEMP over a 50 by 200 m area, provided typical cable response data. REPS provides a 1.5-kV/m horizontal, ground-interacted electric field at the target, 100 m on the centerline, 50 m off the centerline, and 3 m high, with threat-related properties. REPS consists of a Marx generator driving a 1000-ft biconic antenna elevated 60 ft.

Instrumentation was provided by the Mobile Digital Acquisition System (MODAS). This van includes three channels of fiber-optic data linkup to the transmitter and probe, two digitizers per channel, data reduction equipment, and displays. Table 3 describes the limitations of the instrumentation used in the test.

Personnel consisted of an electronics technician, a simulator operator, and a test engineer. Tests were conducted daily from 21 April through 8 May 1987, began at 8:00 am, and ended after checkout and shutdown at 4:00 pm.

Table 2. EMP and lightning parameters

Parameter	All lightning strikes			HEMP ≤50 kV/m
	5% <1 kA	50% <3.3 kA	95% <100 kA	
Risetime 10-90%	0.28 $\mu$ s	0.8 $\mu$ s	8 $\mu$ s	0.01 $\mu$ s
Falltime to 50%	45 $\mu$ s	130 $\mu$ s	170 $\mu$ s	0.4 $\mu$ s
Slew rate	3.6 kA/ $\mu$ s	4.3 kA/ $\mu$ s	12.5 kA/ $\mu$ s	5000 kV/ $\mu$ s

Source: Cyanos and Pierce, *A Ground-Lightning Environment, Tech Report 1, Stanford Research Institute (August 1972)*.

Table 3. Instrumentation characteristics

Instrument	Bandwidth	Error (%)
SRI E010 and E204 E-field sensors	10 kHz to 10 MHz	10
Tektronix P6009 voltage probe	dc to 400 MHz	2
Tektronix P6021 current probe	100 Hz to 200 MHz	10
Stoddard 94430 current probe	20 Hz to 200 MHz	15
Nanofast Optic transmitter/receiver set	dc to 120 MHz	5
Tektronix digitizer 7912AD	dc to 200 MHz	5

## 2. HEMP RADIATION TESTS

### 2.1 Test Setup

Before testing, the shielded room was erected upon a stable wood platform about 80 m from the REPS and 50 m off the centerline, as shown by figure 1. Instruments for mapping the outside and inside of the shielded room and for measuring voltages and currents each side of the penetration protective devices were set up and calibrated. The test points are described in table 4.

Tests were performed on two of each type of line so as to sample two of each protective device (e.g., AUD1 and AUD2). Voltage measurements were single ended to ground; inner conduc-

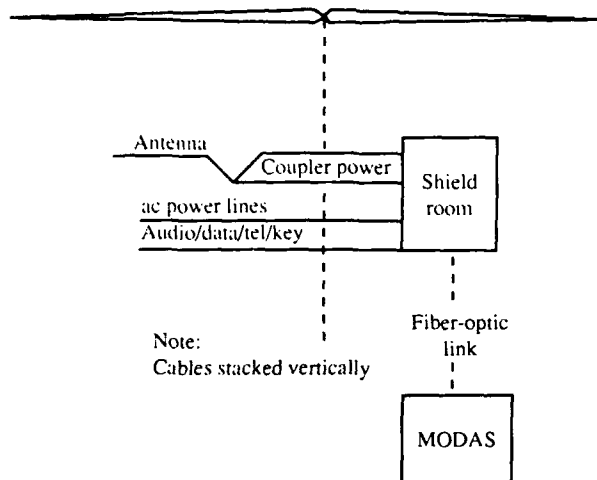

Figure 1. Radiated HEMP test configuration and test points.

Table 4. Test point description

At all test points except mapping points EXO and EXI, outside voltage, inside voltage, and inside current were measured.

Test point	Location
EXO	Mapping point 1 m in front, 1 m from ground
EXI	Mapping point 1 m inside, 1 m from floor
SAC	400-V (4.7- $\Omega$ ) wire at entry panel
SACN	200-V (15- $\Omega$ ) wire at entry panel
COU	39-V (120- $\Omega$ ) wire at entry panel
AUD	12-V (650- $\Omega$ ) wire at entry panel
DAT	12-V (160- $\Omega$ ) wire at entry panel
TEL	110-V (650- $\Omega$ ) wire at entry panel
KEY	22-V (1-k $\Omega$ ) wire at entry panel
XMT	2000-V (tuner) coax at tuner unit
RCV	250-V (50- $\Omega$ ) coax at load resistor

tor current measurements were taken from around the same conductor. The pulse injector was set up outside the entry panel. An E-field mapping box was centrally placed, 1 m in front of the shielded room, at a 1-m elevation.

### 2.2 Test Procedure for Pulsed E-Field Measurements

1. Align the E-sensor on the mapping box to measure the field parallel to the REPS antenna. Verify the settings for expected trigger, amplitude, risetime, and ringdown.

2. End-to-end calibrate the instrumentation and record a pulse.

3. Scale the instrumentation and digitizer for resolution.

4. Pulse the test point as often as necessary to record data with repeatability and reversibility. On occasion, record the level of ambient noise and instrumentation-coupled HEMP.

5. Evaluate the data.

6. Move the mapping box into the shielded room 1 m from the center of the front wall, and 1 m above the floor. Align the sensor exactly as was done for the outside measurements. Repeat steps 3, 4, and 5 for test points EXI, EYI, and EZI.

7. At the conclusion of each test period, turn off the instruments, secure the area, and notify the REPS personnel.

### 2.3 Test Procedure for cw E-Field Measurements (MIL-STD-285)

1. Set up transmitter, receiver, and antenna outside the HFRF. Connect feedwires to the HFRF at test points 1 and 23.

2. Turn on the transmitter and tune to 95 kHz.

3. Insert the receiving antenna into the calibration port of the transmitter and adjust the gain control until 0 dB is read on the receiver meter.



4. Move the receiving antenna to each of the 12 different positions inside the RFI-tight HFRF and record the decibel meter reading.

5. Repeat steps 2 through 4 using 450 MHz and the Retlif TS450 test set and calibrating procedures, about 10 ft from the HFRF.

#### **2.4 Test Procedure for Coupled Responses**

1. Attach the voltage and current probe to the chosen 120-V line inside the entry panel. Attach a voltage probe to the same line outside the entry panel. Verify the settings for the expected response.

2. End-to-end calibrate the instrumentation and record a pulse.

3. Scale the instruments and digitizer for resolution.

4. Pulse the test point as often as necessary to record data with repeatability and reversibility. On occasion, record the level of ambient noise and instrumentation-coupled HEMP.

5. Evaluate the data.

6. Proceed to the next test point and repeat steps 3, 4, and 5.

7. At the conclusion of each test period, turn off the instruments, secure the area, and notify the REPS personnel.

#### **2.5 Test Procedure for Injection Responses**

1. Attach the voltage and current probe to the chosen ac line inside the entry panel. Attach a voltage probe to the same line outside the entry panel. Verify the settings for expected triggering, amplitude, risetime, and ringdown.

2. End-to-end calibrate the instruments and record a pulse.

3. Scale the instruments and digitizer for optimum resolution of amplitude and time.

4. Pulse the test point as often as necessary to record data with repeatability and reversibility.

5. Evaluate the data.

6. Proceed to the next test point and repeat steps 3, 4, and 5.

7. At the conclusion of each test period, turn off the instruments and secure the area.

### 3. TEST DATA REDUCTION

Figures 2 through 13 show test data; all data were recorded at least twice to demonstrate repeatability and occasionally to show reversed polarity.

#### 3.1 Electrical Field

Figure 2 shows the electrical fields with and without REPS. An EMP free field at threat level is 50 kV/m within 10 to 25 ns of start. The reflection of this free field off the electrical ground causes cancellation with a delay depending on the height of measurement. Vertical fields and radial fields are of minor strength, so the shielding effectiveness of the HFRF can be reasonably accurately represented as

$$SE = 20 \log(EXI/EXO) .$$

The 1-m-high data show 220 V/m after 13 ns, because of cancellation of the field before the free field maximum arrives. The same location with a 3-m height shows 1.6 kV/m after 25 ns, demonstrating a time for the peak to arrive before the ground cancelling wave arrives. This 1.6-kV/m value is comparable to a threat amplitude. The threat scale factor is therefore (50 kV/m)/(1.6 kV/m) or 0.032. The shielding effectiveness is calculated as

$$\begin{aligned} SE &= 20 \log(0.04/150) \\ &= -72 \text{ dB} . \end{aligned}$$

This value is better than the -60 dB criterion. The EMP level inside the HFRF resembles the noise level outside.

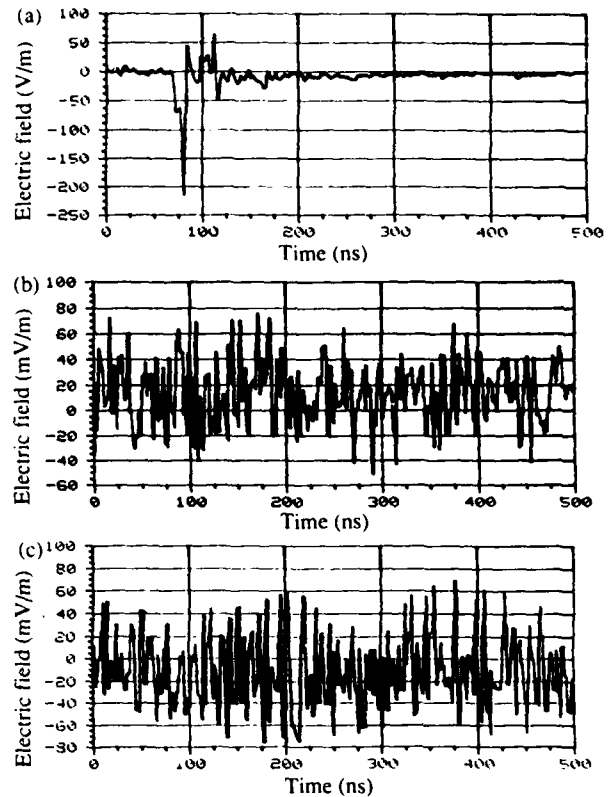

Figure 2. Electric field data: (a) horizontal field outside shelter with REPS on, (b) ambient horizontal field outside shelter (without REPS), and (c) horizontal field inside shelter (with REPS).

### 3.2 cw field

Figure 3 shows the response of the HFRF to the cw field. Although the shielding effectiveness varied day to day, it always exceeded the criterion of  $-60$  dB. The HFRF was not intended to be exposed to the extremes of temperature and humidity that it underwent during this testing (it sat on a wood platform under a tent outdoors during April), but the use of brass wool under the bolts and the lack of calibrated torquing for evenly distributed seam bonding pressure suggest that the HFRF shielding effectiveness could be substantially improved. The shield passes the criterion.

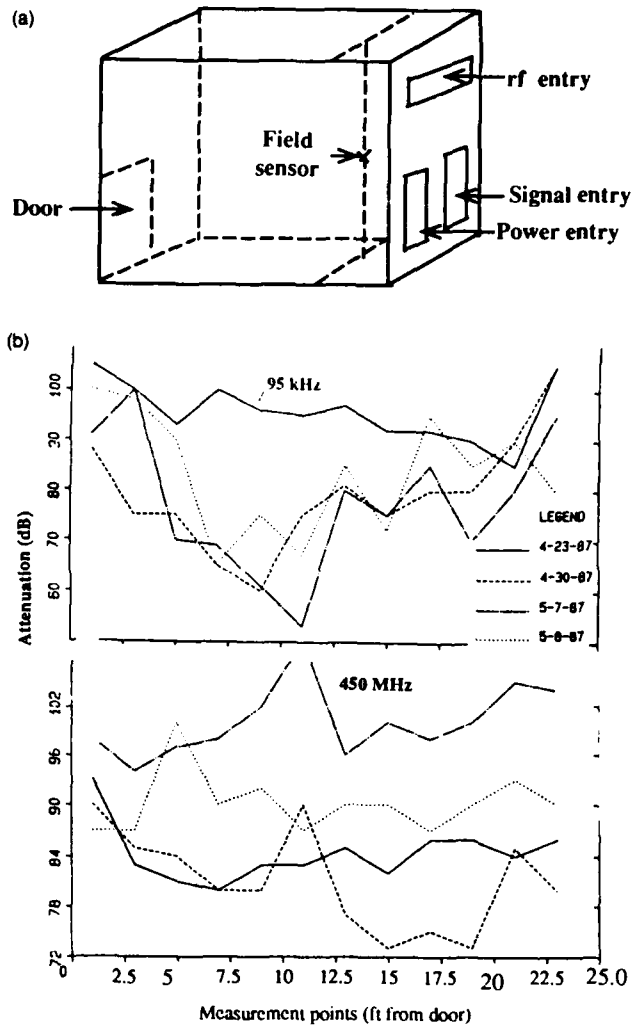

Figure 3. Response of HFRF to cw field: (a) field sensor location in shield room and (b) field measurements over time.

### 3.3 ac Power Lines

The response of the ac power source to REPS (fig. 4) shows a 10-V, 0.5-A (20- $\Omega$ ) penetration to the 4.7- $\Omega$  load. When scaled to threat, this represents 320 V, 16 A, still below the protection level of 400 V. The 0.7-MHz ringing observed represents the 300-ft line quarter-wave resonance:

$$f = 0.8c/\lambda,$$

where  $f$  = frequency,  
 $c$  = speed of light, and  
 $\lambda$  = wavelength.

Since the current travels 300 ft (which equals a quarter wavelength), the frequency = 0.667 MHz. The injection voltage shows a 17-MHz ringing. Since the cables are not connected, this ringing represents the reflection of the injection current at the impedance mismatch of the shorting protective spark gap. Previous predictions, based on an in-line filter, are invalid. The injected pulse measured 400 V, 14 A (28  $\Omega$ ), equal to the 400 V of the protective device. The 4.7- $\Omega$  load looks like 20 to 30  $\Omega$  to the transient.

The ac power source lines are judged to be hard to EMP, and to half of all probable lightning strokes as well, although the current criterion of 10 A was exceeded. A 1-kV pulse on an apparent 20- $\Omega$  load would yield 50 A, which would be a more appropriate criterion to use.

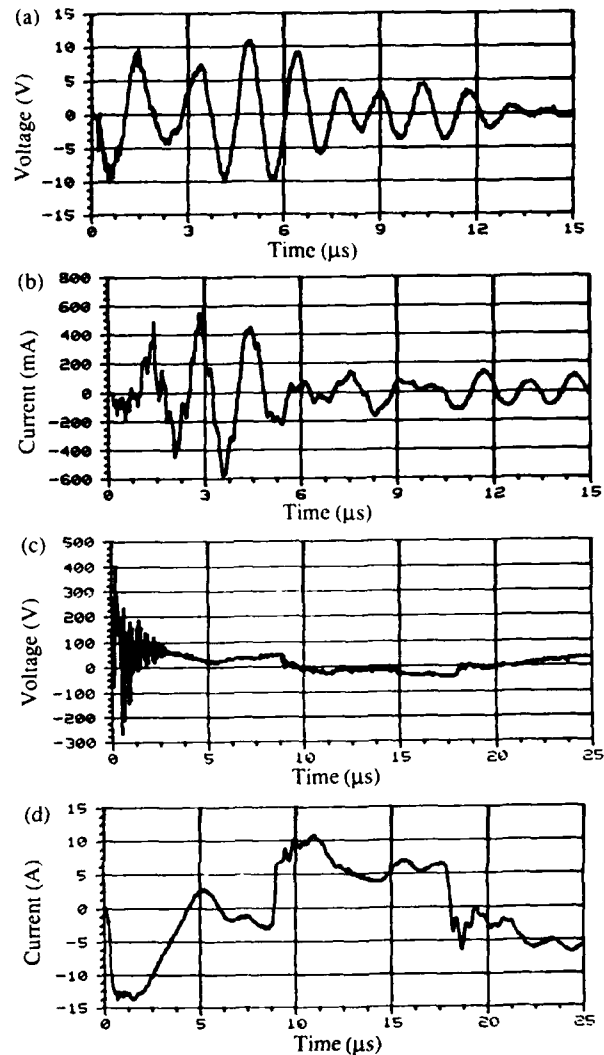

Figure 4. Response of ac power source line: (a) voltage response to REPS, (b) current response to REPS, (c) voltage response to injection, and (d) current response to injection.

### 3.4 ac Power Neutral Line

The response of the ac power neutral to REPS (fig. 5) shows a 7-V, 0.5-A (14- $\Omega$ ) penetration to the 4.7- $\Omega$  load. When scaled to the threat, this represents 250 V, 16 A, just above the protection level of 200 V. The 0.7-MHz ring observed represents the 300-ft line resonance.

Injection data show a 0.11-MHz ringing. The cables are not connected, so this represents the resonance of the injection reactance and the HFRF reactance. Data show 60 V, 14 A (4.2  $\Omega$ ), exceeding the 400 V of the protective device. No explanation of this low and inconsistent apparent resistive value can be found, so the data are considered bad. The ac power source neutral lines are hard to EMP. The protective device found to be effective on the phase line should be twice as effective on the neutral line, so this line is assumed (but not proven) to be hard to half of all lightning strokes as well.

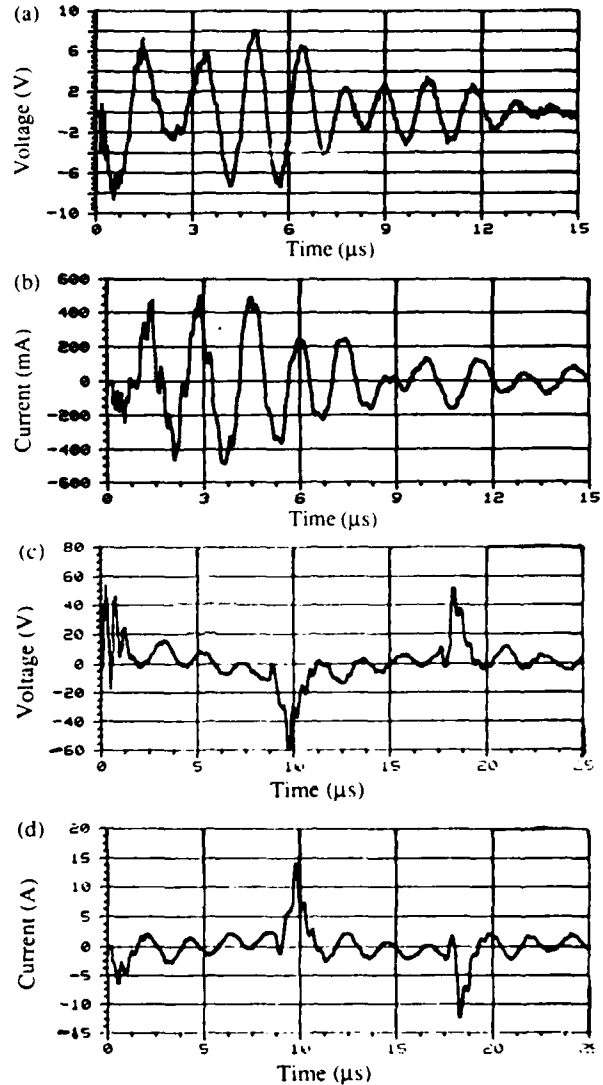

Figure 5. Response of ac power neutral line: (a) voltage response to REPS, (b) current response to REPS, (c) voltage response to injection, and (d) current response to injection.

### 3.5 ac Power Auxillary Line

The response of the ac power auxiliary line to the REPS field (fig. 6) shows a 12-V, 0.5-A (24- $\Omega$ ) penetration to the 15- $\Omega$  load. When scaled to threat, this represents 375 V, 16 A, still below the protection level of 400 V. The 0.7-MHz ring observed represents the 300-ft line resonance.

Injection data show a 0.11-MHz ringing. The 120-V, 15-A response (8  $\Omega$ ) is less than the 200 V of the protective device. Because the virtual impedance measures less than that for the real load with no cable, we conclude that these data are bad.

The ac power auxiliary lines are hard to EMP. The protective device found effective on the source phase line will probably (and should) be installed on the auxiliary lines, so this line is assumed (but not proven) to be hard to half of all lightning strokes as well.

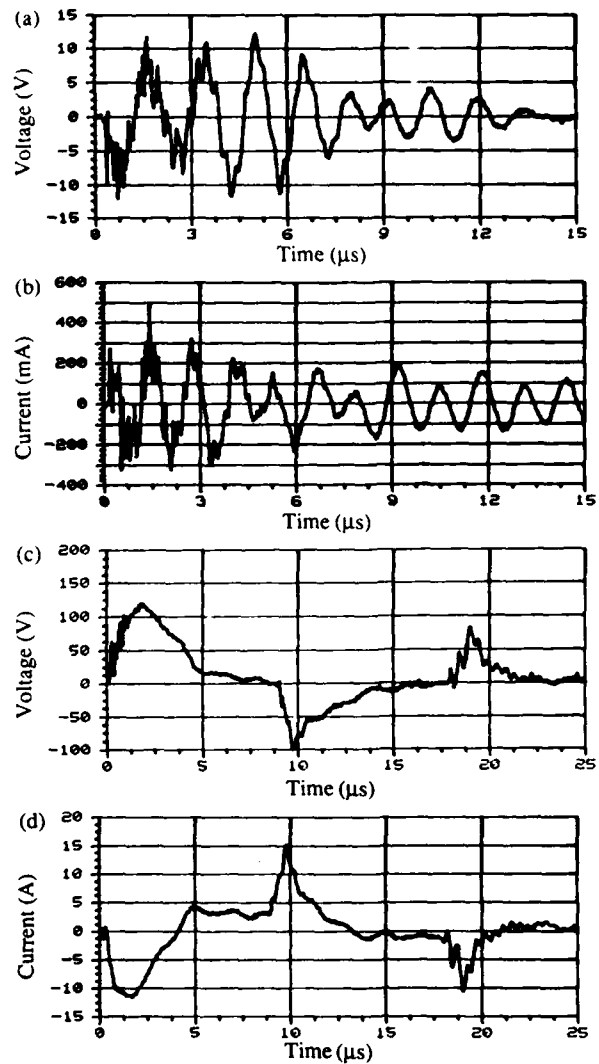

Figure 6. Response of ac power auxiliary line: (a) voltage response to REPS, (b) current response to REPS, (c) voltage response to injection, and (d) current response to injection.

### 3.6 ac Power Coupler

The response of the ac power coupler to the REPS field (fig. 7) shows a 330-mV, 20-mA (17- $\Omega$ ) penetration to the 120- $\Omega$  load (see below). These low values, when compared to the unshielded power lines (10 V), show an effective cable shield of 30 dB. When scaled to threat, this represents 10 V, 6 A, still below the protection level of 39 V. The 0.7-MHz ringing observed represents the 300-ft line quarter-wave resonance. The shielded cable characteristic impedance dominates the transient, rather than the load (which is suspected to have been 12  $\Omega$ , not 120  $\Omega$ ).

Injection data show a 0.11-MHz ringing. The data show a 300-V, 14-A (22- $\Omega$ ) response into 120  $\Omega$ ; this response rings as if there were a spark gap mismatch around 200 V, 7 A, decaying to zero except for a long-term (0.11 MHz) ringing as observed on the neutral ac data. This is not consistent with the 39-V Zener device protection, but does meet the criterion of 1 kV, 10 A. The response is as if a 150-V Zener device (not a spark gap) is actually in place. The ac coupler lines are hard to EMP and to half of all lightning strokes.

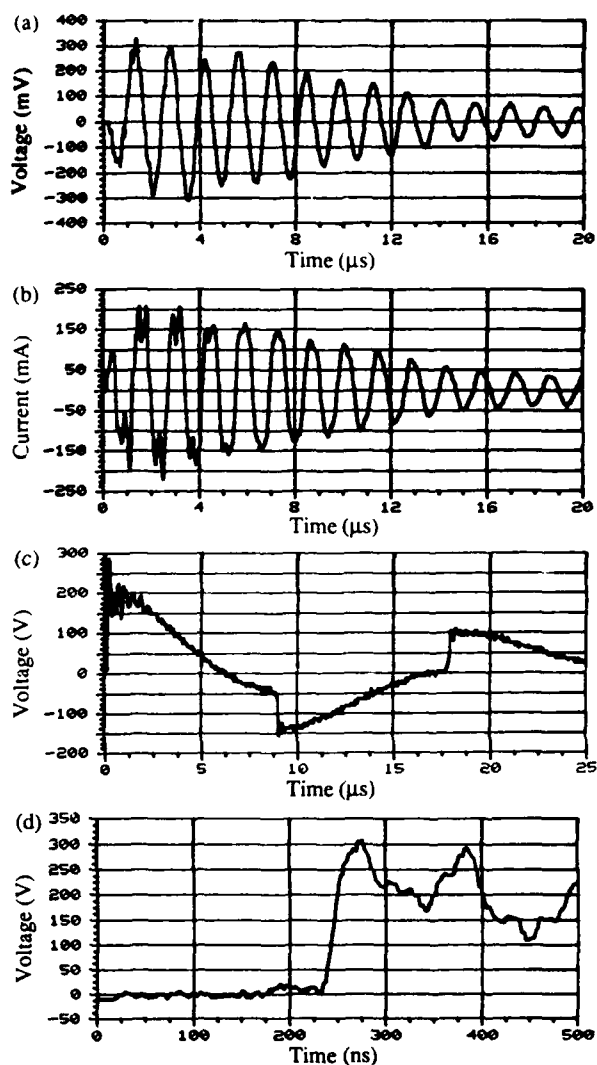

Figure 7. Response of ac power coupler line: (a) voltage response to REPS, (b) current response to REPS, (c) voltage response to injection (late time ringdown), and (d) voltage response to injection (early time peak).

### 3.7 Digital Signal Lines

The response of the digital lines to REPS (fig. 8) shows 4.5 V outside and 4 V inside the HFRF. This is less than the 12-V Zener protection. The current is similar in ringing but reads 75 mA (60  $\Omega$ ) going into the HFRF and 19 mA (210  $\Omega$ ) inside the HFRF. This factor of four seems large for the impedance mismatch from cable to shelter, even for a 0.67-MHz ringing frequency, but there is no filter or insertion loss involved. The ringing corresponds to the cable length. Extrapolated to threat levels, the inside values would correspond to 125 V and 0.6 A, which the 12-V Zener will clamp to an overshoot under 20 V. The injection response has a transient overshoot of 120 V, 380 mA (315  $\Omega$ ), with a half-power duration of about 50 ns, reflecting a slow switching time. There may be substantial parasitic inductance to slow the Zener action down. The pulse continues around 30 V for several microseconds, as is expected. The bulk resistance of the MOS device is about 0.5  $\Omega$ , which accounts for the additional voltage as the large amount of current is shunted to ground. The 380-mA current shown in the data is what is left after the Zener current is drained off.

The digital signal lines are judged to be hard to HEMP and half of all lightning strokes.

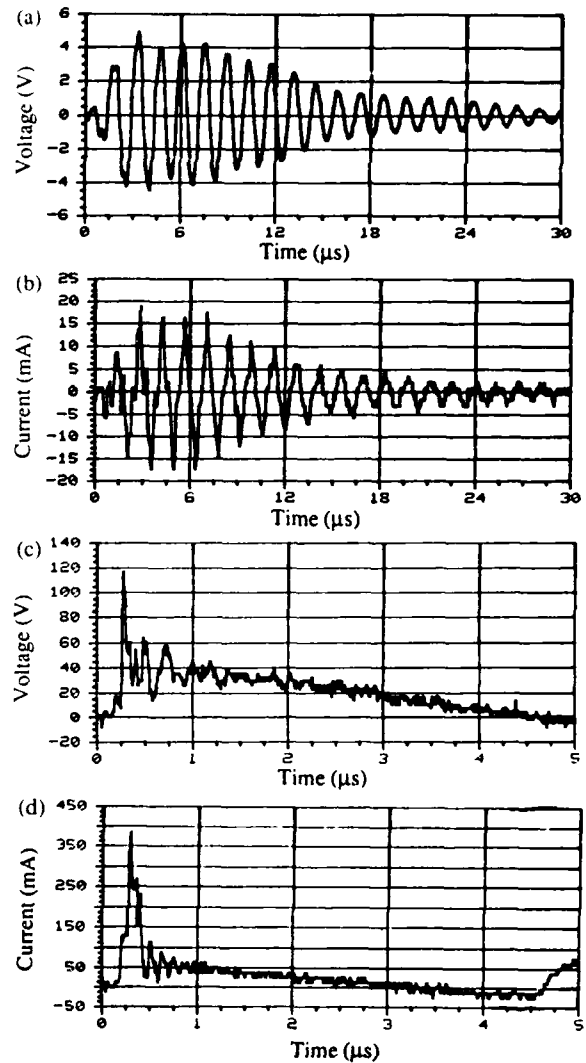

Figure 8. Response of digital signal lines: (a) voltage response to REPS, (b) current response to REPS, (c) voltage response to injection, and (d) current response to injection.



### 3.8 Audio Signal Lines

The response of the audio signal lines to the REPS environment (fig. 9) shows 210 mV, 1.5 mA (140  $\Omega$ ), demonstrating the effectiveness of the cable shield and its termination. This response extrapolates to 6.6 V and 47 mA for threat level, well below the 12-V Zener protection provided by the 11845-10 device. The characteristic 0.67-MHz ringing for 300 ft is changed to a 0.53-MHz ringing because of the slower velocity of conduction within the shielded cable. The HFRF audio signal lines are demonstrated to be hard to HEMP even without the protective devices.

The lightning injection pulse is applied to the conductor within the shield in order to test the capacity of the protection devices. This is an extreme test since the shield would provide excellent protection, as was demonstrated by the REPS data. A 130-V, 0.5-A (260- $\Omega$ ) response was observed, with the voltage duration being 70 ns. This indicates a slow switching time, but is not reason to doubt the hardness of the circuit.

The audio signal lines are judged to be hard to both HEMP and half of all lightning strokes.

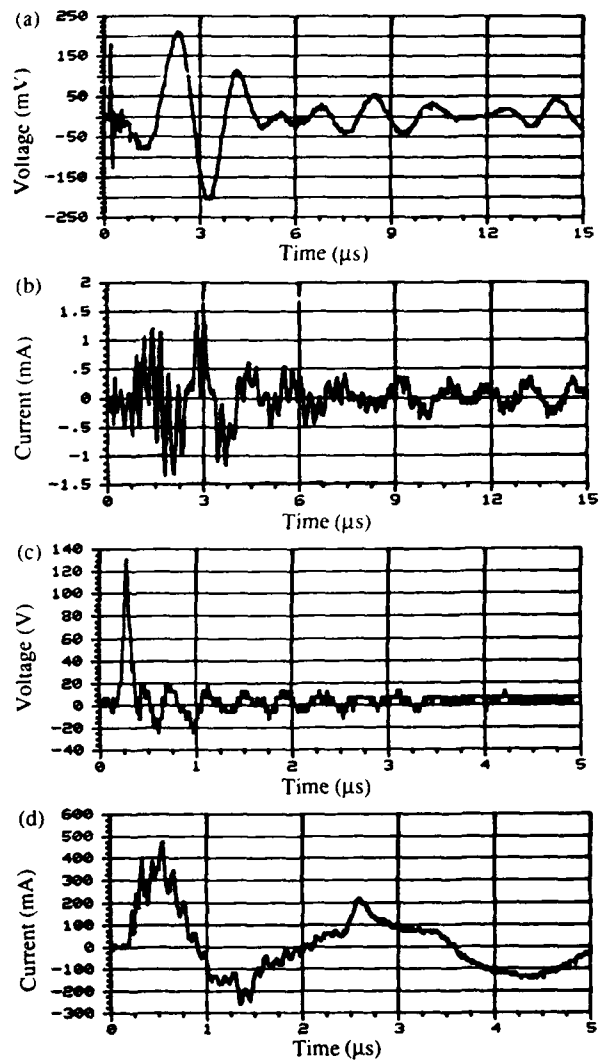

Figure 9. Response of audio signal lines: (a) voltage response to REPS, (b) current response to REPS, (c) voltage response to injection, and (d) current response to injection.

### 3.9 Telephone Lines

The response of the telephone signal lines to the REPS HEMP (fig. 10) shows 500 mV, 2.8 mA (180  $\Omega$ ). When extrapolated to threat levels, these would register as 15.6 V and 87 mA. The 11845-100 protective device with a 100-V Zener would clamp these levels (as demonstrated by the injection test data) well within the criterion of 100 V, 10 A. These low levels are a result of the shielding protection around the lines. The ringing shows characteristics of the 300-ft line and a slower propagation velocity. The HFRF telephone lines are clearly hard to HEMP.

The lightning injection pulse was applied to the interface without cable attached, to test the capacity of the protective device. A surge of 180 V, 450 mA lasted for 50 ns, showing a slow switching time for the device. Levels promptly settled to zero, indicating a spark gap. Although the voltage criterion is exceeded, this circuit is probably hard to 50 percent of all lightning strikes, since the shield of the cable would divert much more than 10 times the energy injected. The HFRF telephone lines are judged hard to the average lightning threat.

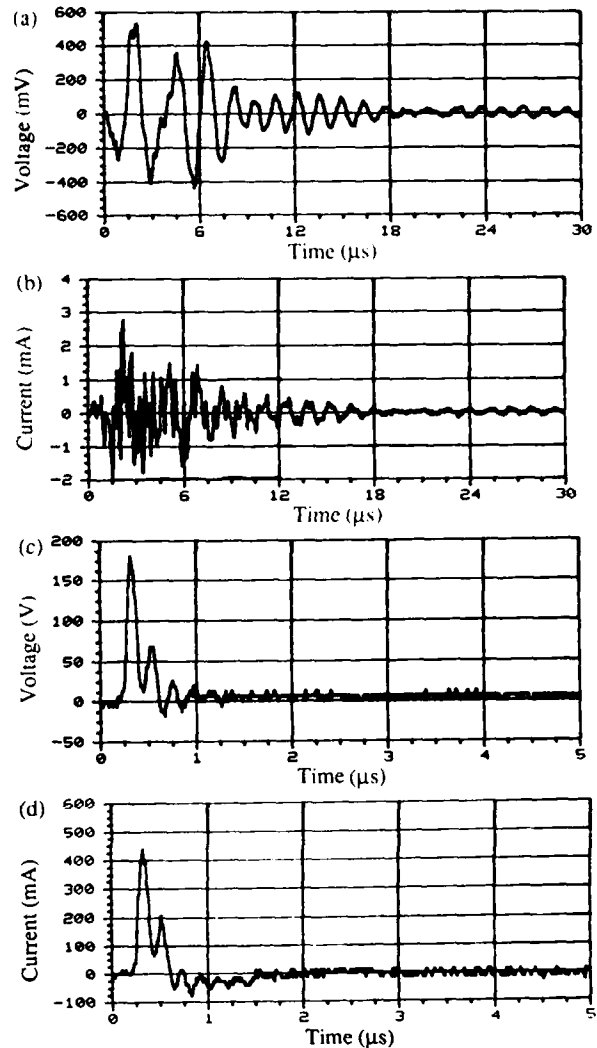

Figure 10. Response of telephone signal lines: (a) voltage response to REPS, (b) current response to REPS, (c) voltage response to injection, and (d) current response to injection.

### 3.10 Teletype Lines

The response of the teletype signal lines to the REPS HEMP (fig. 11) shows a peak voltage of 65 mV and a peak current of 20 mA (3.3  $\Omega$ ). When extrapolated to threat levels, these register as 2 V and 650 mA. The 11895-20 protective device with a 22-V Zener would clamp these levels (as demonstrated by the injection test data) well within the criterion. These low levels are a result of the shielding protection around the lines. The characteristic ringing again shows the 300-ft line and a slower propagation velocity. The HFRF telephone lines are clearly hard to HEMP.

The lightning injection pulse was applied to the interface without cable attached in order to test the capacity of the protective device. A surge of 120 V, 370 mA (324  $\Omega$ ) lasts for 50 ns, showing a slow switching time for the device. Levels promptly settle to zero, indicating a spark gap. Although the voltage criterion is exceeded, this circuit is judged hard to half of all lightning strikes since the shield would divert most of the energy from a lightning stroke.

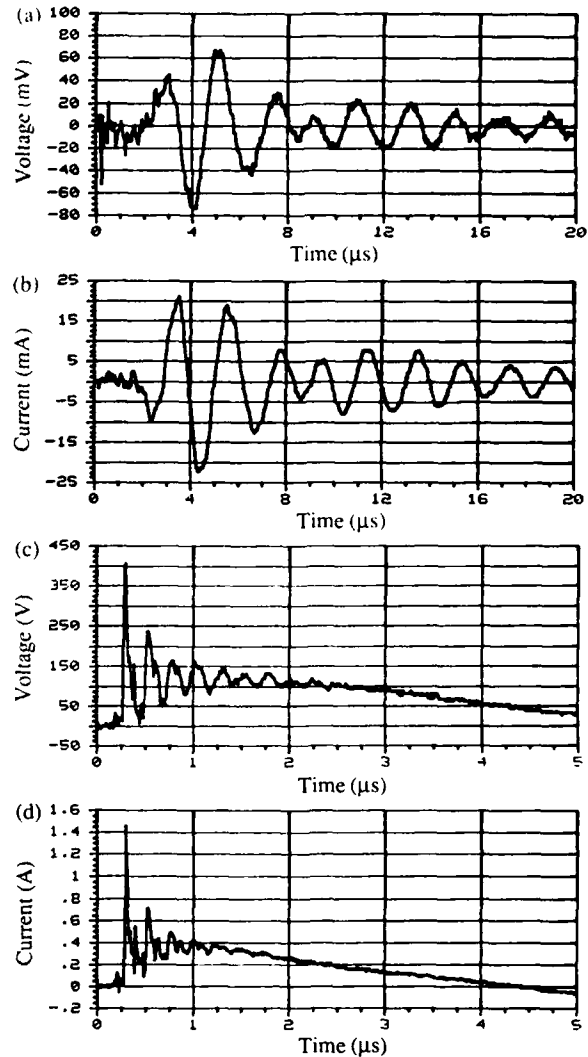

Figure 11. Response to teletype signal lines: (a) voltage response to REPS, (b) current response to REPS, (c) voltage response to injection, and (d) current response to injection.

### 3.11 Transmitter Lines

The transmitter protection device was connected between a tuned circuit load and a dipole antenna for the REPS tests. This dipole was on the centerline, 15 ft above the ground. The response of the transmitter mode to REPS HEMP (fig. 12) shows 225 V, 20 mA (1250  $\Omega$ , 50  $\Omega$  at tuned frequency only) on the center of the coax. When extrapolated to threat levels these would register as 7 kV, 0.5 A. The protective device with a 2-kV spark gap should reduce these levels to a level well within the criterion, but does so too slowly, as shown by the injection data. Since only 20 ns of transient will survive, the rf tuning elements can store the energy and attenuate the level safely for the next components. The 15-MHz ringing is due to the tuned frequency of the dipole and the tuned transmitter, dominating the frequency characteristic for the 270-ft length of coax. These lines are judged hard to HEMP.

The lightning injection pulse was applied to the interface without the cable attached in order to test the capacity of the device. A surge of 2.4 kV lasted for 20 ns, showing a faster switching time for the device. Arcing was observed inside the transmitter, but since lightning would strike the outside of the coax, which is grounded, this circuit is judged to be hard to an average lightning stroke.

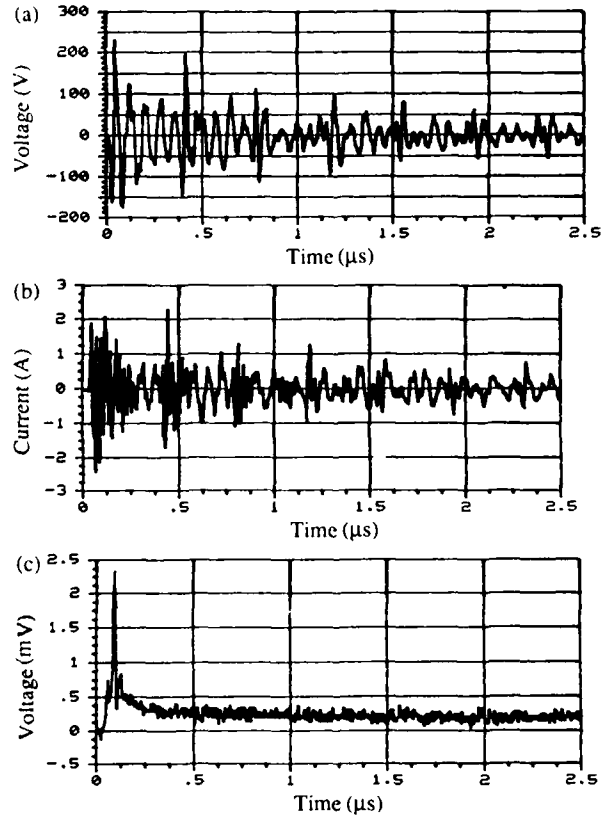

Figure 12. Response of transmitter lines: (a) voltage response to REPS, (b) current response to REPS, and (c) voltage response to injection.

### 3.12 Receiver rf Lines

The receiver 250-V protection device was connected between the 50- $\Omega$  load and the 2-kV protection device at the shield wall. Response of the receiver mode to REPS HEMP (fig. 13) shows 120 V, 3.5 A (34  $\Omega$ ) on the center of the coax. Extrapolated to threat levels, these register as 3.8 kV and 110 A. The protective devices with a 2-kV spark gap and a 250-V Zener should reduce these levels to a level well within the criterion. The 15-MHz ringing is the tuned frequency of the dipole, but damps out faster than that for the transmitter because of the losses in the 50- $\Omega$  load compared to the tuned circuit. Like the transmitter, the receiver couples almost all of its energy from the antenna and very little energy from the coax. The HFRF rf lines are judged hard to HEMP.

The lightning injection pulse was applied to the interface without the cable attached. A surge of 2.8 kV lasted for 20 ns, showing the same switching time as for the transmitter. The voltage criterion is exceeded, but with the cable attached this circuit is judged hard to an average lightning stroke.

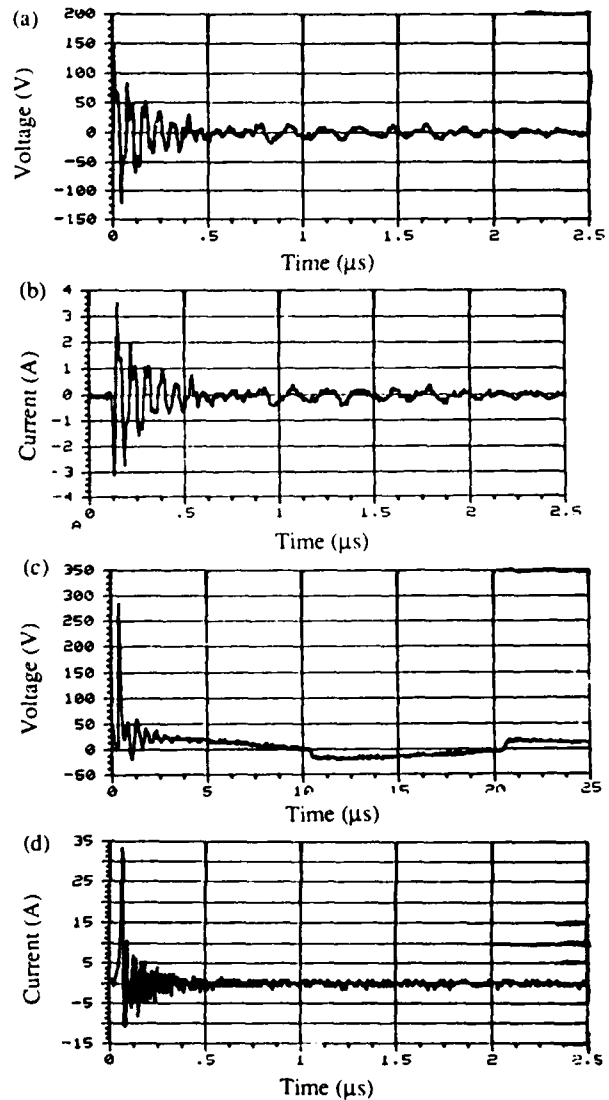

Figure 13. Response of receiver rf lines: (a) voltage response to REPS, (b) current response to REPS, (c) voltage response to injection, and (d) current response to injection.

#### 4. CONCLUSIONS

The hf radio shield room in a configuration approved by the FAA was tested for EMP protection and was judged to be hardened to HEMP. The same configuration was tested for a hardness to half of all probable lightning strikes and was judged to be hard to this threat as well (see table 5).

Some test points failed the hardness criteria, but were passed, as explained when the data were presented. The field values from REPS are extrapolated and do not show protection device effects. Injection bypasses shielding for test points COU, DAT, AUD, TEL, KEY, XMT, and RCV.

There is reason to think with some confidence that the hf radio shield room, as configured, is hard to an HEMP environment and to half of all lightning strokes. The criteria notwithstanding, most (shield-circumvented) injected excess voltages and currents are of short duration (50 ns), and the parasitic reactances of the harness and shelter would reduce these substantially before the equipment

was exposed. The energy in these spikes is very small, and the endurance of components increases as the duration of stress decreases. Nonetheless, arcing in the XMT tuner did occur. A definitive answer to this issue would require a test with the equipment and wire harness in place and measurements made at the equipment. Possible insight may be gained by characterization tests on the protective devices to identify switching times, voltage overshoot from current and resistance, and possible installation reactances (circuit or ground- ing) which may be improved.

A serious problem was not addressed. The HFRF power protection design includes a gas-filled spark gap without self-quenching. As an EMP or lightning transient ionizes this gas, the ac power supply maintains the ionization until the resultant short circuit causes a circuit breaker to throw. This shuts down the radios, with the loss of any ongoing communications links. To avoid this upset it is recommended that a self-quenching type of spark gap be used to replace the existing one.

Table 5. HFRF HEMP/lightning test measurement points

Test point	Function	REPS scaled threat HEMP		Injected lightning		Criteria		Results	
		(V)	(mA)	(V)	(mA)	(kV)	(A)	By criteria	By judgement
SAC	Source power	320	16,000	400	14,000	1	10	fail	pass
AAC	Auxiliary power	375	16,000	(bad data)		1	10	fail	pass
COU	Coupler power	10	6,000	200	7,000	1	10	fail	pass
DAT	Digital line	125	600	120	380	0.1	10	pass	pass
AUD	Audio line	6.6	47	130	550	0.1	10	pass	pass
TEL	Telephone line	15.6	87	180	450	0.1	10	pass	pass
KEY	Teletype line	2	650	400	1,500	0.1	10	pass	pass
XMT	rf line transmit	7000	500	2400	na	10	500	pass	pass
RCV	rf line receive	3800	110,000	290	34,000	10	500	pass	pass

DISTRIBUTION

ADMINISTRATOR  
DEFENSE TECHNICAL INFORMATION CENTER  
CAMERON STATION, BUILDING 5  
ATTN DTIC-DDA (12 COPIES)  
ALEXANDRIA, VA 22304-6145

ASSISTANT TO THE SECRETARY OF DEFENSE  
ATOMIC ENERGY  
ATTN EXECUTIVE ASSISTANT  
WASHINGTON, DC 20301

DIRECTOR  
DEFENSE COMMUNICATIONS AGENCY  
ATTN CODE B410  
ATTN CODE B430  
WASHINGTON, DC 20305

DIRECTOR  
COMMAND CONTROL ENGINEERING CENTER  
ATTN C-660  
ATTN G-630  
WASHINGTON, DC 20305

DIRECTOR  
DEFENSE COMMUNICATIONS ENGINEERING CENTER  
ATTN CODE R400  
ATTN CODE R123, TECH LIB  
ATTN CODE R111  
1860 WIEHLE AVENUE  
RESTON, VA 22090

ASSISTANT CHIEF OF STAFF FOR  
INFORMATION MANAGEMENT  
COMMAND SYSTEMS INTEGRATION OFFICE  
ATTN DAMO-C4Z  
THE PENTAGON  
WASHINGTON, DC 20301

DIRECTOR  
DEFENSE INTELLIGENCE AGENCY  
ATTN DB-4C2, D. SPOHN  
WASHINGTON, DC 20301

CHAIRMAN  
JOINT CHIEFS OF STAFF  
ATTN J-3  
ATTN C3S  
WASHINGTON, DC 20301

NATIONAL COMMUNICATIONS SYSTEM  
DEPARTMENT OF DEFENSE  
OFFICE OF THE MANAGER  
ATTN NCS-TS, D. BODSON  
WASHINGTON, DC 20305

DIRECTOR  
DEFENSE NUCLEAR AGENCY  
ATTN RAEV  
ATTN DDST  
ATTN RAEF

DIRECTOR  
DEFENSE NUCLEAR AGENCY (cont'd)  
ATTN TITL  
WASHINGTON, DC 20305

OFFICE OF UNDERSECRETARY OF DEFENSE  
RESEARCH & ENGINEERING  
DMSSO  
2 SKYLINE PLACE  
SUITE 1403  
5203 LEESBURG PIKE  
FALLS CHURCH, VA 22041

UNDER SECY OF DEF FOR RSCH & ENGRG  
DEPARTMENT OF DEFENSE  
ATTN STRATEGIC & SPACE SYS 9050 RM 3E129  
ATTN STRAT & THEATER NUC FORCES  
WASHINGTON, DC 20301

DEPUTY DIRECTOR FOR THEATRE/TACTICAL C3  
SYSTEMS  
JOINT STAFF  
WASHINGTON, DC 20301

COMMANDER-IN-CHIEF  
US FORCES, EUROPE  
ATTN ECC3S  
APO, NY 09128

ASSISTANT CHIEF OF STAFF FOR  
AUTOMATION & COMMUNICATIONS  
ATTN DAMO-C4T  
ATTN DAMO-C4S  
DEPARTMENT OF THE ARMY  
WASHINGTON, DC 20360

US ARMY BALLISTIC RESEARCH  
LABORATORY  
ATTN DRDAR-TSB-S (STINFO)  
ABERDEEN PROVING GROUND, MD 21005

US ARMY COMBAT SURVEILLANCE & TARGET  
ACQUISITION LABORATORY  
ATTN DELET-DD  
FT MONMOUTH, NJ 07703

COMMANDER  
US ARMY ELECTRONIC SYSTEMS ENGINEERING  
INSTALLATION AGENCY  
ATTN ASBH-SET-S  
FORT HUACHUCA, AZ 85613

US ARMY ENGINEER DIV HUNTSVILLE  
DIVISION ENGINEER  
ATTN HNDED FD,  
PO BOX 1600  
HUNTSVILLE, AL 35807

DISTRIBUTION (cont'd)

COMMANDER  
US ARMY INFORMATION SYSTEMS COMMAND  
ATTN CC-OPS-WR, O.P. CONNELL/R. NELSON  
FT HUACHUCA, AZ 85613

COMMANDER  
US ARMY INFORMATION SYSTEMS  
ENGINEERING COMMAND  
SUPPORT ACTIVITY  
ATTN ASB-TS-A, B. EGBERT  
FORT MONMOUTH, NJ 07703-5000

COMMAND  
US ARMY MATERIEL COMMAND  
ATTN DRCRE  
ATTN DRCDE  
5001 EISENHOWER AVE  
ALEXANDRIA, VA 22333-0001

DIRECTOR  
US ARMY MATERIEL SYSTEMS ANALYSIS  
ACTIVITY  
ATTN DRXSY-MP, LIBRARY  
ABERDEEN PROVING GROUND, MD 21005

COMMANDER  
US ARMY MISSILE COMMAND  
ATTN DRCPM-CF, CHAPARRAL/FAAR  
ATTN DRCPM-HD, HELLFIRE/GLD  
ATTN DRCPM-PE, PERSHING  
ATTN DRCPM-DT, TOW DRAGON  
ATTN DRCPM-RS, GENERAL SUPPORT  
ROCKET SYS  
ATTN DRCPM-HEL, HIGH ENERGY LASER SYS  
ATTN DRCPM-ROL, ROLAND  
ATTN DRCPM-VI, VIPER  
ATTN DRCPM-HA, HAWK  
ATTN DRCPM-MP, STINGER  
ATTN DRSMI-U, WEAPONS SYS MGT DIR  
ATTN DRSMI-D, PLANS, ANALYSIS,  
& EVALUATION  
ATTN DRSMI-Q, PRODUCT ASSURANCE  
ATTN DRSMI-S, MATERIEL MANAGEMENT  
ATTN DRSMI-W, MGMT INFO SYSTEMS  
REDSTONE ARSENAL, AL 35809

DIRECTOR  
US ARMY MISSILE LABORATORY  
USAMICOM  
ATTN DRSMI-RPR, REDSTONE SCIENTIFIC  
INFO CENTER  
ATTN DRSMI-RPT, TECHNICAL  
INFORMATION DIV  
ATTN DRSMI-RN, CHIEF, TECHNOLOGY  
INTEGRATION OFFICE  
ATTN DRSMI-RA, CHIEF, DARPA PROJECTS  
OFFICE  
ATTN DRSMI-RH, DIR, DIRECTED ENERGY  
DIRECTORATE

DIRECTOR  
US ARMY MISSILE LABORATORY (cont'd)  
USAMICOM  
ATTN DRSMI-RL, SPE ASST GROUND EQUIP &  
MISSILE STRUCTURES DIR  
ATTN DRSMI-RR, RESEARCH DIR  
ATTN DRSMI-RS, SYS ENGR DIR  
ATTN DRSMI-RT, TEST & EVAL DIR  
ATTN DRSMI-RD, SYST SIMULATION & DEV DIR  
ATTN DRSMI-RE, ADVANCED SENSORS DIR  
ATTN DRSMI-RK, PROPULSION DIR  
ATTN DRSMI-RG, GUIDANCE & CONTROL DIR  
REDSTONE ARSENAL, AL 35809

COMMANDER  
US ARMY MISSILE & MUNITIONS  
CENTER & SCHOOL  
ATTN ATSK-CTD-F  
REDSTONE ARSENAL, AL 35809

COMMANDER  
US ARMY NUCLEAR & CHEMICAL AGENCY  
ATTN MONA-WE  
7500 BACKLICK ROAD  
SPRINGFIELD, VA 22150

OFFICE OF THE ASSIST SEC  
OF THE ARMY (RDA)  
DEPARTMENT OF THE ARMY  
ATTN DAMA-CSS-N  
WASHINGTON, DC 20310

CHIEF  
US ARMY SATELLITE COMMUNICATIONS  
AGENCY  
ATTN DRCPM-SC  
FT MONMOUTH, NJ 07703

DIRECTOR  
TRI/TAC  
ATTN TT-E-SS, CHARNICK  
FT MONMOUTH, NJ 07703

COMMANDANT  
US ARMY WAR COLLEGE  
ATTN LIBRARY  
CARLISLE BARRACKS, PA 17013

COMMANDER-IN-CHIEF  
ATLANTIC  
ATTN J6  
NORFOLK, VA 23511

COMMANDER  
NAVAL ELECTRONIC SYSTEMS COMMAND  
ATTN PME 110-241D  
WASHINGTON, DC 20360



DISTRIBUTION (cont'd)

NAVAL ELECTRONICS ENGINEERING ACTIVITY,  
PACIFIC  
BOX 130  
ATTN DON O'BRYHIM  
PEARL HARBOR, HAWAII 96860-5170

CHIEF OF NAVAL MATERIEL  
THEATER NUCLEAR WARFARE PROJECT OFFICE  
ATTN PM-23  
WASHINGTON, DC 20360

COMMANDER  
NAVAL OCEAN SYSTEMS CENTER  
ATTN CODE 83, J. STAWISKI  
SAN DIEGO, CA 92152

COMMANDING OFFICER  
NAVAL ORDNANCE STATION  
ATTN STANDARDIZATION DIVISION  
INDIAN HEAD, MD 20640

COMMANDER-IN-CHIEF  
PACIFIC  
ATTN C3S-RP-1  
CAMP H. M. SMITH, HI 96861

COMMANDING OFFICER  
NAVAL RESEARCH LABORATORY  
ATTN CODE 4720, J. DAVIS  
WASHINGTON, DC 20375

COMMANDER  
NAVAL SURFACE WEAPONS CENTER  
ATTN CODE F-56  
DAHLGREN, VA 22448

COMMANDER  
NAVAL SURFACE WEAPONS CENTER  
ATTN CODE F32, E. RATHBURN  
ATTN CODE F30  
WHITE OAK LABORATORY  
SILVER SPRING, MD 20910

DEPARTMENT OF THE NAVY  
DIRECTOR, NAVAL TELECOMMUNICATIONS  
DIVISION  
OFFICE OF THE CHIEF OF NAVAL OPERATIONS  
ATTN OP941, HAISLMAIER  
ATTN OP943  
WASHINGTON, DC 20350

HQ, USAF/SAMI  
WASHINGTON, DC 20330

AIR FORCE COMMUNICATIONS COMMAND  
ATTN EPPD  
SCOTT AFB, IL 62225

COMMANDER  
US AIR FORCE SPACE COMMAND  
ATTN KRQ  
PETERSON AFB, CO 80912

1842 EEG  
ATTN EEISG  
SCOTT AFB, IL 62225

HEADQUARTERS  
USAFE  
ATTN DCKI  
RAMSTEIN AFB, GERMANY

SYSTEM INTEGRATION OFFICE  
ATTN SYE  
PETERSON AFB, CO 80912

AIR FORCE WEAPONS LABORATORY/DYC  
ATTN NTC4, TESD, IESM  
KIRTLAND AFB, NM 87117

CENTRAL INTELLIGENCE AGENCY  
ATTN OWSR/NED  
WASHINGTON, DC 20505

DIRECTOR  
FEDERAL EMERGENCY MANAGEMENT AGENCY  
NATIONAL PREPAREDNESS PROGRAM SUPPORT  
ATTN OFFICE OF RESEARCH  
WASHINGTON, DC 20472

DIRECTOR  
FEDERAL EMERGENCY MANAGEMENT AGENCY  
STATE & LOCAL SUPPORT BR  
ATTN SL/EM/SS/LS, LOGISTICS  
SUPPORT BRANCH  
WASHINGTON, DC 20472

LAWRENCE LIVERMORE NATIONAL LAB  
ATTN TECHNICAL INFO DEPT LIBRARY  
ATTN L-156, H. CABAYAN, L. MARTIN  
PO BOX 808  
LIVERMORE, CA 94550

DIRECTOR  
NATIONAL SECURITY AGENCY  
ATTN R15  
9800 SAVAGE ROAD  
FT MEADE, MD 20755

AMERICAN TELEPHONE & TELEGRAPH CO  
ATTN SEC OFC FOR W. EDWARDS  
1120 20TH STREET, NW  
WASHINGTON, DC 20036

DISTRIBUTION (cont'd)

AT&T BELL LABORATORIES  
ATTN R. STEVENSON  
1600 OSGOOD ST  
N. ANDOVER, MA 01845

AT&T BELL LABORATORIES  
ATTN J. SERRI  
CRAWFORDS CORNER ROAD  
HOLMDEL, NJ 07733

BDM CORP  
ATTN CORPORATE LIBRARY  
7915 JONES BRANCH DRIVE  
McLEAN, VA 22102

BOEING CO  
PO BOX 3707  
ATTN R. SHEPPE  
SEATTLE, WA 98124

ENGINEERING SOCIETIES LIBRARY  
ATTN ACQUISITIONS DEPT  
345 E. 47TH ST  
NEW YORK, NY 10017

ENSCO, INC  
ATTN R. GRAY  
540 PORT ROYAL RD  
SPRINGFIELD, VA 22151

IIT RESEARCH INSTITUTE  
ATTN J. BRIDGES  
ATTN I. MINDEL  
10 W 35TH STREET  
CHICAGO, IL 60616

INTERNATIONAL TEL & TELEGRAPH CORP  
ATTN A. RICHARDSON  
ATTN TECHNICAL LIBRARY  
500 WASHINGTON AVENUE  
NUTLEY, NJ 07110

MARTIN MARIETTA CORPORATION  
PO BOX 5837  
ATTN DR. C. WHITESCARVER  
ORLANDO, FL 32805

MISSION RESEARCH CORP  
ATTN TOM BOLT  
735 STATE STREET  
SANTA BARBARA, CA 93102

MISSION RESEARCH CORP  
ATTN W. STARKE  
4935 N. 30TH STREET  
COLORADO SPRINGS, CO 80933

MISSION RESEARCH CORP  
EM SYSTEM APPLICATIONS DIVISION  
ATTN A. CHODOROW  
1720 RANDOLPH ROAD, SE  
ALBUQUERQUE, NM 87106

PRI, INC  
ATTN W. HAAS  
6121 LINCOLNIA RD  
ALEXANDRIA, VA 22312

R&D ASSOCIATES  
ATTN W. GRAHAM  
PO BOX 9695  
MARINA DEL REY, CA 90291

R&D ASSOCIATES  
ATTN DIRECTOR, DR. J. THOMPSON  
1401 WILSON BLVD  
SUITE 500  
ARLINGTON, VA 22209

ROCKWELL INTERNATIONAL CORP  
ATTN D/243-068, 031-CA31  
PO BOX 3105  
ANAHEIM, CA 92803

SCIENCE ENGINEERING ASSOC  
ATTN P. FLEMMING  
ATTN V. JONES  
701 DEXTER AVE, N  
SEATTLE, WA 98109-4318

SRI INTERNATIONAL  
ATTN A. WHITSON  
ATTN E. VANCE  
333 RAVENSWOOD AVENUE  
MENLO PARK, CA 94025

TRW DEFENSE & SPACE SYSTEMS GROUP  
ATTN J. PENAR  
ONE SPACE PARK  
REDONDO BEACH, CA 92078

TRW DEFENSE & SPACE SYSTEMS GROUP  
ATTN E. P. CHIVINGTON  
2240 ALAMO, SE  
SUITE 200  
ALBUQUERQUE, NM 87106

GEORGIA INSTITUTE OF TECHNOLOGY  
OFFICE OF CONTRACT ADMINISTRATION  
ATTN RES & SEC COORD FOR H. DENNY  
ATLANTA, GA 30332

DISTRIBUTION (cont'd)

US ARMY LABORATORY COMMAND  
ATTN TECHNICAL DIRECTOR, AMSLC-TD

INSTALLATION SUPPORT ACTIVITY  
ATTN LEGAL OFFICE, SLCIS-CC

USAISC  
ATTN RECORD COPY, ASNC-LAB-TS  
ATTN TECHNICAL REPORTS BRANCH,  
ASNC-LAB-TR (2 COPIES)

HARRY DIAMOND LABORATORIES  
ATTN D/DIVISION DIRECTORS  
ATTN LIBRARY, SLCIS-IM-TL (3 COPIES)  
ATTN LIBRARY, SLCIS-IM-TL (WOODBRIDGE)  
ATTN LAB DIRECTOR, SLCHD-NW-E  
ATTN CHIEF, SLCHD-NW-EP  
ATTN CHIEF, SLCHD-NW-EH (15 COPIES)  
ATTN CHIEF, SLCHD-NW-ES  
ATTN CHIEF, SLCHD-NW-P  
ATTN CHIEF, SLCHD-NW-R  
ATTN CHIEF, SLCHD-NW-TN  
ATTN CHIEF, SLCHD-NW-RP  
ATTN CHIEF, SLCHD-NW-TS  
ATTN CHIEF, SLCHD-NW-RS

HARRY DIAMOND LABORATORIES (cont'd)  
ATTN CHIEF, SLCHD-TT  
ATTN H. LESSER, SLCHD-IT-EB  
ATTN J. O. WEDEL, JR., SLCHD-IT-EB  
ATTN B. ZABLUDOWSKI, SLCHD-IT-EB  
ATTN A. FRYDMAN, SLCHD-IT-RT (2 COPIES)  
ATTN R. J. CHASE, SLCHD-NW-EP  
ATTN A. HERMANN, SLCHD-NW-EP  
ATTN C. LE, SLCHD-NW-EP  
ATTN A. NGUYEN, SLCHD-NW-EP  
ATTN R. J. REYZER, SLCHD-NW-EP  
ATTN D. TROXEL, SLCHD-NW-EP  
ATTN R. L. ATKINSON, SLCHD-NW-EH (15 COPIES)  
ATTN H. E. BOESCH, JR., SLCHD-NW-RP  
ATTN C. FAZI, SLCHD-NW-CS  
ATTN R. KAUL, SLCHD-NW-CS  
ATTN P. B. JOHNSON, SLCHD-ST-A  
ATTN W. WIEBACH, SLCHD-ST-MW  
ATTN P. ALEXANDER, SLCHD-ST-SA  
ATTN C. ARSEM, SLCHD-ST-SA  
ATTN D. M. HULL, SLCHD-ST-SA  
ATTN J. LOWE, SLCHD-ST-SA  
ATTN J. DENT, SLCHD-TA-F (2 COPIES)  
ATTN R. GOODMAN, SLCHD-TA-ES  
ATTN S. C. SANDERS, SLCHD-NW-EH (5 COPIES)