

# NAVAL POSTGRADUATE SCHOOL Monterey, California

AD-A209 075



**S** DTIC  
ELECTE  
JUN 22 1989  
**D**

## THESIS

INCORPORATING INFORMATION VALUE INTO  
NAVY TACTICAL DATA SYSTEM  
SYSTEM CONFIGURATION MANAGEMENT  
THROUGH THE DELPHI METHOD

by

Barbara Lynn Ketcham

March 1989

Thesis Advisor                      Thomas M. Mitchell

Approved for public release; distribution is unlimited.

89 6 20 031

Unclassified

security classification of this page

REPORT DOCUMENTATION PAGE

1a Report Security Classification: <b>Unclassified</b>		1b Restrictive Markings	
2a Security Classification Authority		3 Distribution/Availability of Report	
2b Declassification/Downgrading Schedule		Approved for public release; distribution is unlimited.	
4 Performing Organization Report Number(s)		5 Monitoring Organization Report Number(s)	
5a Name of Performing Organization <b>Naval Postgraduate School</b>	6b Office Symbol <i>(if applicable)</i> <b>39</b>	7a Name of Monitoring Organization <b>Naval Postgraduate School</b>	
6c Address (city, state, and ZIP code) <b>Monterey, CA 93943-5000</b>		7b Address (city, state, and ZIP code) <b>Monterey, CA 93943-5000</b>	
8a Name of Funding/Sponsoring Organization	8b Office Symbol <i>(if applicable)</i>	9 Procurement Instrument Identification Number	
8c Address (city, state, and ZIP code)		10 Source of Funding Numbers	
		Program Element No	Project No
		Task No	Work Unit Accession No
11 Title (include security classification): <b>INCORPORATING INFORMATION VALUE INTO NAVY TACTICAL DATA SYSTEM SYSTEM CONFIGURATION MANAGEMENT THROUGH THE DELPHI METHOD</b>			
12 Personal Author(s): <b>Barbara Lynn Ketcham</b>			
13a Type of Report <b>Master's Thesis</b>	13b Time Covered From To	14 Date of Report (year, month, day) <b>March 1989</b>	15 Page Count <b>47</b>
16 Supplementary Notation: <b>The views expressed in this thesis are those of the author and do not reflect the official policy or position of the Department of Defense or the U.S. Government.</b>			
17 Cosati Codes		18 Subject Terms (continue on reverse if necessary and identify by block number)	
Field	Group	Subgroup	<b>configuration management, Delphi method, Command and Control</b> <i>Thesis</i>
19 Abstract (continue on reverse if necessary and identify by block number) → <b>There is a difficulty in incorporating information value judgments into configuration management decisions regarding command and control systems. This work reviews two command and control process models, decision theory as it relates to command and control and the current tactical data link configuration management method. The Delphi method is discussed and a means of incorporating its use into configuration management is introduced. The Delphi method allows a systematic gathering of subjective information from selected respondents which then enables formulation of a group position. Use of this method would enable subjective assessments, such as perceived operational impact of tactical data link changes, to be systematically considered in Navy tactical data link configuration management decisions.</b>			
20 Distribution/Availability of Abstract: <input checked="" type="checkbox"/> unclassified/unlimited <input type="checkbox"/> same as report <input type="checkbox"/> DTIC users		21 Abstract Security Classification <b>Unclassified</b>	
22a Name of Responding Individual <b>Thomas M. Mitchell</b>		22b Telephone (include Area code) <b>(408) 646-2620</b>	22c Office Symbol <b>55Mi</b>

Approved for public release: distribution is unlimited.

Incorporating Information Value Into  
Navy Tactical Data System  
System Configuration Management  
Through the Delphi Method

by

Barbara Lynn Ketcham  
Lieutenant, United States Navy  
B.S., Winthrop College, 1979

Submitted in partial fulfillment of the  
requirements for the degree of

MASTER OF SCIENCE IN SYSTEMS TECHNOLOGY  
(Command, Control, and Communications)

from the

NAVAL POSTGRADUATE SCHOOL  
March 1989

Author:



Barbara Lynn Ketcham

Approved by:



Thomas M. Mitchell, Thesis Advisor

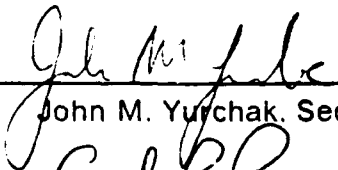

John M. Yurchak, Second Reader

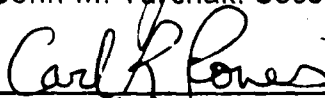

Carl R. Jones, Chairman,  
Command, Control and Communications Academic Group

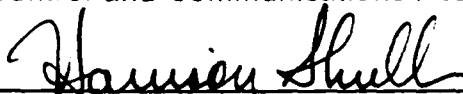

Harrison Shull,  
Provost and Academic Dean

## ABSTRACT

There is a difficulty in incorporating information value judgments into configuration management decisions regarding command and control systems. This work reviews two command and control process models, decision theory as it relates to command and control and the current tactical data link configuration management method. The Delphi method is discussed and a means of incorporating its use into configuration management is introduced. The Delphi method allows a systematic gathering of subjective information from selected respondents which then enables formulation of a group position. Use of this method would enable subjective assessments, such as perceived operational impact of tactical data link changes, to be systematically considered in Navy tactical data link configuration management decisions.

Accession For	
NTIS GRA&I	<input checked="" type="checkbox"/>
DTIC TAB	<input type="checkbox"/>
Unannounced	<input type="checkbox"/>
Justification	
By _____	
Distribution/	
Availability Codes	
Dist	Avail and/or Special
A-1	



## TABLE OF CONTENTS

I. INTRODUCTION .....	1
A. BACKGROUND .....	1
B. OBJECTIVE OF THE STUDY .....	2
C. SCOPE OF THE STUDY .....	2
D. LIMITATIONS .....	2
E. ASSUMPTIONS .....	2
F. DEFINITIONS .....	3
G. ORGANIZATION OF THE STUDY .....	4
II. VIEWPOINTS ON COMMAND AND CONTROL .....	5
A. WHAT DOES DECISION THEORY SAY? .....	5
B. COMMAND AND CONTROL PROCESS MODELS .....	6
1. Lawson's view .....	6
2. Metersky's view .....	8
3. Where does the human fit in? .....	12
C. CURRENT DATA LINK CONFIGURATION MANAGEMENT .....	14
1. A Configuration Management Example .....	15
D. PUTTING IT ALL TOGETHER .....	17
III. INCORPORATING THE DELPHI METHOD INTO CONFIGURATION MANAGEMENT .....	18
A. THE DELPHI METHOD .....	18
1. History .....	18
2. Method of use .....	18
3. Drawbacks and Criticisms .....	19
B. HOW IT CAN BE USED BY NTISA .....	20
IV. IMPLICATIONS IN USING THE DELPHI .....	23

A. BETTER SUPPORT FOR THE TACTICAL DECISIONMAKER .....	23
B. IMPROVED CONFIGURATION MANAGEMENT .....	23
V. CONCLUSIONS AND RECOMMENDATIONS .....	25
A. RECOMMENDATIONS .....	25
APPENDIX A. EXAMPLE QUESTIONS .....	27
APPENDIX B. TUROFF'S POLICY DELPHI SCALES .....	28
LIST OF REFERENCES .....	33
BIBLIOGRAPHY .....	35
INITIAL DISTRIBUTION LIST .....	37

## LIST OF FIGURES

Figure 1.	Lawson's Command and Control Process Model	7
Figure 2.	Metersky's Sense Expansion	9
Figure 3.	Metersky's Process and Compare Expansion	10
Figure 4.	Metersky's Decide Expansion	11
Figure 5.	Metersky's Act Expansion	12
Figure 6.	Metersky's C2 Process Model	13

## ACKNOWLEDGEMENTS

This thesis has my name but I had help from many others. Special thanks to the folks at NTISA for suggesting my topic and actually seeming excited about my answers. Thanks also to my advisor and second reader, LCDRs Mitchell and Yurchak who were much more prompt in returning my drafts than I was in getting them to them. Special consideration and love to my son Richard who seemed to understand when Mama had to "computer" and couldn't help you build "bad guy traps". You are wise beyond your almost five years. I never could have made it without the unfailing love and devotion of my husband who always has confidence that I will make it through *somehow*.



## I. INTRODUCTION

Difficulty exists when system engineers or evaluators try to determine the usefulness of information to a corporate or military decisionmaker. As a result, many systems are designed without evaluating the decisionmaker's value judgments on the information being presented to him. This is especially true in the area of military command and control systems. Communications pathways and connectivity issues are easier to determine than the specific information needs of the commander. This study will present a method to improve the capability of incorporating information value into Navy configuration management decisions.

### A. BACKGROUND

Current emphasis in military budgeting gives rise to measures of effectiveness equaling a steady budget line. Unfortunately, this view often leaves the command and control aspect of command, control and communications unfunded. Since it is difficult to quantify the information needs of the commander and therefore a value cannot be placed on the absence of the information, many valid programs fail to get the continued funding they need. This is exemplified by the delayed fielding of the Joint Tactical Information Distribution System (JTIDS) hardware which implements the TADIL J message standard. Originally to be fielded in the late 1970's, the Navy does not anticipate full implementation prior to 1993.

Within the Navy, some attempts have been made to determine the impact of message translation between two tactical digital data system standards, TADIL A (Link 11) and TADIL J (Link 16). These efforts, although largely unsuccessful, have underscored the need to incorporate decisionmakers' value judgments into Navy configuration management of these data links. This thesis is an effort to meet that need.

## **B. OBJECTIVE OF THE STUDY**

The objective of this study is to identify a method to incorporate various subjective considerations that should be taken into account when making configuration management decisions that affect the inclusion or exclusion of information in a tactical digital data link. It was suggested as a topic by staff members of the Navy Tactical Interoperability Support Activity (NTISA) which is chartered by the Chief of Naval Operations to do configuration management (CM) of the data links under the Joint Interoperability of Tactical Command and Control Systems (JINTACCS) program.

## **C. SCOPE OF THE STUDY**

The scope of this study includes an evaluation of the command and control process from the view of the human decisionmaker. This view draws from both classical and recent research on decision theory. Three C2 process models, each of which expands upon the other, will be reviewed.

It is a difficult to apply quantitative scales to information value as perceived by the decisionmaker. A method will be introduced which may allow for CM decisions to be made in a more scientific manner.

## **D. LIMITATIONS**

A thorough evaluation of the existing method used for CM of the Navy's tactical data links will not be done, but sufficient explanation of the method will be given to help the reader to understand the development of the CM issues discussed. To allow for wider distribution of this work and to keep it unclassified, no pending configuration management items will be discussed. Examples used are of the author's creation and do not represent known CM issues. The focus of this work is on CM within the U. S. Navy although many of the concepts may apply equally well to the other military services.

## **E. ASSUMPTIONS**

The author's basic assumption is the Navy does not adequately include the information value judgments of the decisionmaker in the design and subsequent configuration management of tactical data systems. The classical sci-

entific method is applicable when discussing the process of decisionmaking but does not lend itself to assigning value judgments to a particular piece of information. This inability to determine "value" within the Navy's configuration management has led to difficulty when determinations have to be made about whether to include a particular information message into the data link. As a result, members of configuration management bodies have used various heuristics to guide their decisions. These heuristics, such as perceived operational impact, vary from individual to individual. The group then spends much of its time trying to determine the individual heuristics and compile them into a group position. This process is fraught with difficulty as the military rank of the members tends to unduly influence the group position. (Bennett, 1989)

Another method must exist which allows for heuristics to be taken into account but eliminates the rank structuring of existing configuration management decision making process. This method should allow for some anonymity by the CM decisionmakers, allow for a methodical review of issues and be able to treat non-quantitative problems. This method should also be easy to incorporate into the existing configuration management process.

## F. DEFINITIONS

The following definitions are given to assist the reader. If no reference is given, the definition is that of the author.

- **Configuration management.** A discipline applying technical and administrative direction and surveillance to:
  1. Identify and document the functional and physical characteristics of a configuration item.
  2. Control changes to those characteristics.
  3. Record and report change processing and implementation status (NTISA, 1987, 2-2).
- **Command and Control.** The exercise of authority and direction by a properly designated commander over assigned forces in the accomplishment of the mission. Command and control functions are performed through an arrangement of personnel, equipment, communications, facilities, and procedures which are employed by a commander in planning, directing, coordinating, and controlling forces and operations in the accomplishment of the mission (JCS Pub 1).

- **Configuration item.** A system and its associated standards which need to be controlled to allow for optimal performance of the system.

## **G. ORGANIZATION OF THE STUDY**

Chapter Two focuses on existing research in the area of command and control process, evaluating two current process models. Classical decision theory is discussed and related to military decisionmaking. It examines the current configuration management process and relates this to the hardware and software view of C3 concluding with the author's perspective of the human role in C2.

Chapter Three discusses the Delphi method and relates it to use in Navy configuration management with Chapter Four focusing on the implications of the method being used in CM. The final chapter presents the author's conclusions and recommendations and gives suggestions for further study.

## II. VIEWPOINTS ON COMMAND AND CONTROL

This chapter discusses various viewpoints that influence the focus of command and control. Pertinent research on decision theory will be presented. Two descriptive C2 process models are discussed and contrasted. The chapter concludes with a description and evaluation of the current U. S. Navy configuration management scheme for tactical digital data links.

### A. WHAT DOES DECISION THEORY SAY?

The modern roots of decision theory (DT) can be traced to von Neumann and Morganstern, an economist and mathematician respectively, who described utility theory as a method for determining why people make the decisions they do. A decision analyst uses the six concepts listed below to evaluate the decisions made by a particular decisionmaker. This evaluation is used to assist a decisionmaker in acting in consonance with his established priorities. These six major concepts are:

- *probability*
- *utility*
- *aggregation*
- *decision*
- *choice*
- *preference.*

Probability and utility are subjective assignments unique to the decisionmaker and the situation. Probability, in this usage, is the decisionmaker's determination of the likelihood of occurrence of the situation. The utility of an alternative under consideration is in the mind of the decisionmaker. Decision theory assumes it must be measurable, at least on an ordinal, if not a cardinal scale. This measurement would be conducted by a decision analyst but is not explicitly done by the decisionmaker. The third concept is aggregation: the decisionmaker's activity which combines the probability and utility of various alternatives in order to choose between them. Decision theorists group decision, choice and preference together. An analysis of the probability, utility and

aggregation values of the decisionmaker should lead to a preference among alternatives with a choice option between alternatives. This process would then result in a decision being made.

Decision theory researchers do not appear to be bothered by decisionmakers not always acting in consonance with the judgments, such as probability and utility, which they assign to the alternatives under consideration. The researchers merely want to identify the logic behind decisions and help the decisionmakers identify when they are not acting in accordance with their values. (Hammond, 1980, 44-67)

In its recent development, Keeney and Raiffa . . . emphasize the point that the aim of DT is to elaborate the logical entailments of the subjective probability and utility theory and extend them to a variety of circumstances. . . . DT makes no claim that it represents or describes the cognitive activity (or information processing) of human decision makers. (Hammond, 1980, 43-44)

Decision theorists avoid determinations of what decisionmakers do but focus instead on the values and judgments which they place on the information used to make the decision. Extending this to the configuration management process, one may conclude various alternatives under consideration will have varying levels of value to the user based on the perceived probability and utility of the alternative to the commander. Assuming this is true, such information value judgments should be considered in the configuration management of command and control systems.

## **B. COMMAND AND CONTROL PROCESS MODELS**

Various models have been created in an attempt to describe the command and control process. This section discusses Lawson's model, Metersky's expansion of Lawson's model, and then evaluates them in terms of the human's role in the process.

### **1. Lawson's view**

In his report, "State Variables of a Command Control System" Lawson

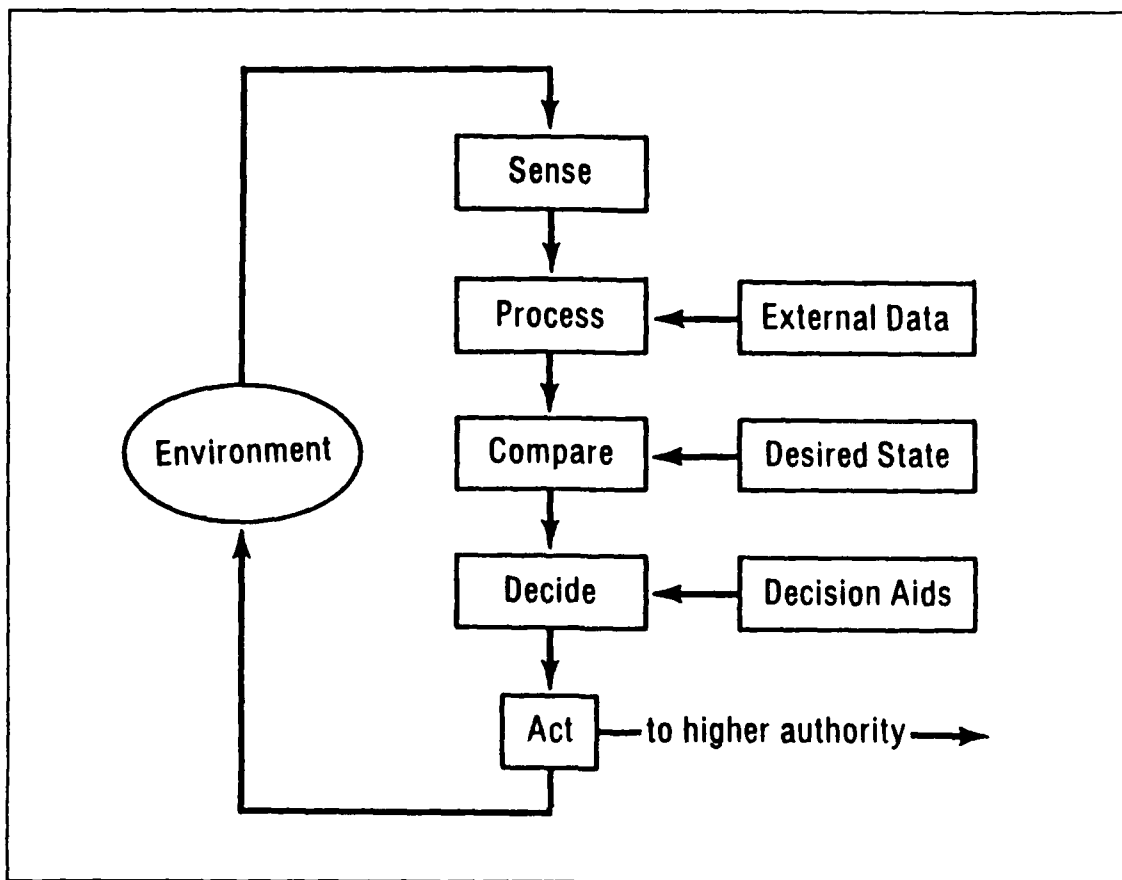

Figure 1. Lawson's Command and Control Process Model

describes five basic functions of a C2 system.<sup>1</sup> As illustrated in Figure 1 these five functions are:

- *sense*
- *process*
- *compare*
- *decide*
- *act.*

<sup>1</sup> This section is the author's evaluation of Lawson, J. S., "The State Variables of a Command Control System," *Proceedings for Quantitative Assessment of the Utility of Command and Control Systems*, Office of the Secretary of Defense with the cooperation of the MITRE Corporation, C<sup>3</sup>Division (Washington, D.C.: National Defense University, Ft. Leslie J. McNair, January 1980), 93-99.

As described by Lawson, *sensing* is the gathering of signals in the form of data from the environment. This data can include radar returns, imagery reports or reports from human observers. This data is then *processed* and external data may be introduced. Processing implies the conversion of raw data to information which can then be used to *compare* the existing state to the desired state.

After comparing, the next function performed is *decide*. The decide function can be supported by decision aids and is based on information from the previous three functions. These decision aids can include automated data bases which allow the decisionmaker to review historical information about the situation, graphical plots of units' position, or expert systems which can recommend courses of action based on the information available.

The last function is *act*. The goal of this function is to influence the environment to produce the desired state as used in the *compare* function. In many cases, actions are communicated to higher authorities. Input from higher authorities may then enter the loop as external data in the *process* function.

## 2. Metersky's view

In 1986, Dr. Mort Metersky of the Naval Air Development Center published a paper expanding Lawson's C2 process model.<sup>2</sup> In this he states:

[t]he C<sup>2</sup> system is a combination of elements that form a complex whole. This C<sup>2</sup> system is composed of two inter-dependent parts: 1) a C<sup>2</sup> *process* consisting of people, procedures, and organizations and 2) *physical components*, e.g., sensors, computers, and communications. The major function of the C<sup>2</sup> process is to provide decision specific information to the responsible decisionmaker, whereas the physical components provide the mechanism for initiating and implementing the C<sup>2</sup> process. (Metersky, 1986, 880) (italics added for emphasis)

Metersky states there are three perspectives of command and control systems that should each be evaluated with various techniques from different

---

<sup>2</sup> This section is the author's evaluation of Metersky, M. L., "A C<sup>2</sup> Process and an Approach to Design and Evaluation," *IEEE Transactions on Systems, Man, and Cybernetics*, v. SMC-16, no. 6, November/December 1986: 880-889.



disciplines. These three perspectives are the total system, the C2 process and the physical components. (Metersky, 1986, 880)

Metersky takes each of the five functions identified in Lawson's model and expands them to specifically include each subfunction necessary to do the function and the organizational relationships that are implied by Lawson's treatment.

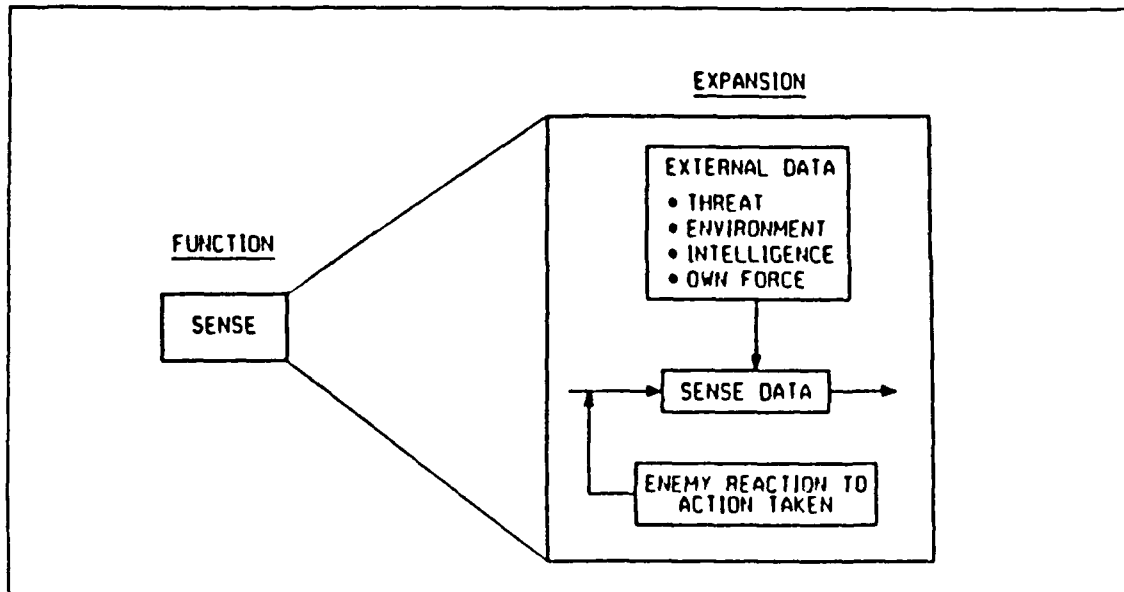

Figure 2. Metersky's Sense Expansion

In Figure 2 note the explicit representation of the expanded sense function. As in Lawson's model, the sense function is devoted to assimilation of raw data from various sources. An additional data set included is the perception of the enemy's reaction to the action taken. This assimilated data then serves as input to the process function.

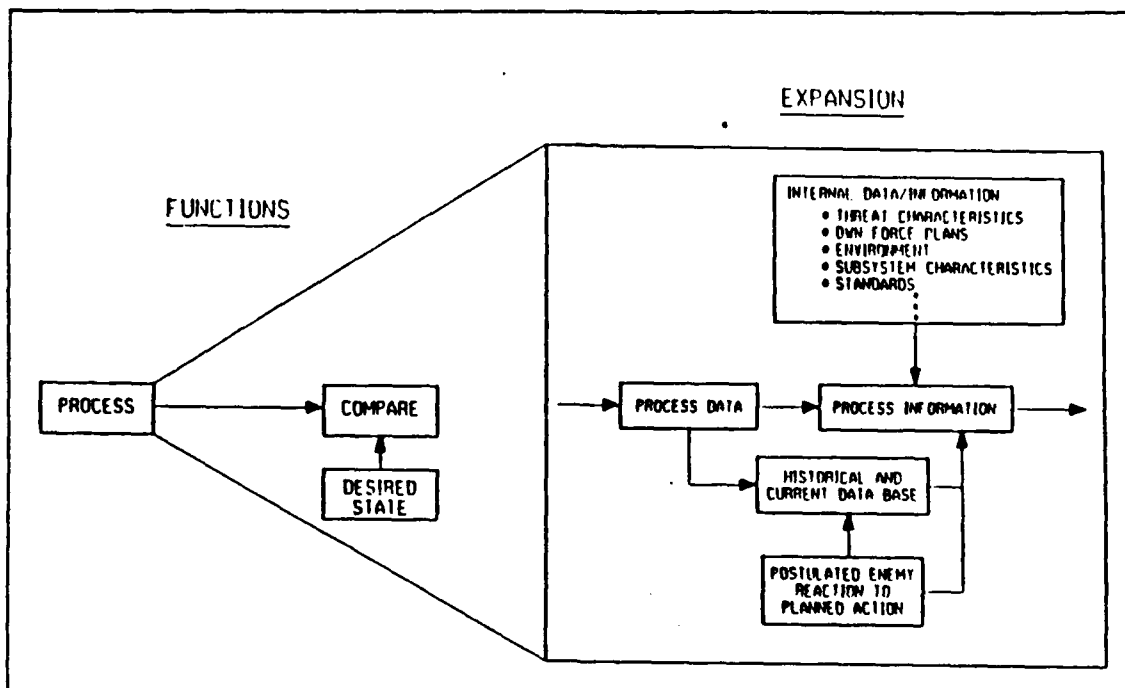

Figure 3. Metersky's Process and Compare Expansion

Metersky groups the *process* and *compare* functions since both work together to provide information to the decisionmaker. In both the Lawson and Metersky models the decisionmaker may be either a human or a machine. Noteworthy is Metersky's view of the decision requirements of the decisionmaker within the organizational structure being the driving force behind the compare method used. Figure 3 refers.

Figure 4 on page 11 shows the expanded version of the *decide* function. Within the dotted box, he includes various cognitive factors that affect decisionmaking by a human. These factors include the decisionmaker's determination of the quality of the input received, human filtering such as experience, both recent and past history, biases and effects of the environment. The decisionmaker takes all this information and internally processes it to come to a decision. The cognitive factors included by Metersky as germane to the *decide* function can also be introduced into expert system machines and

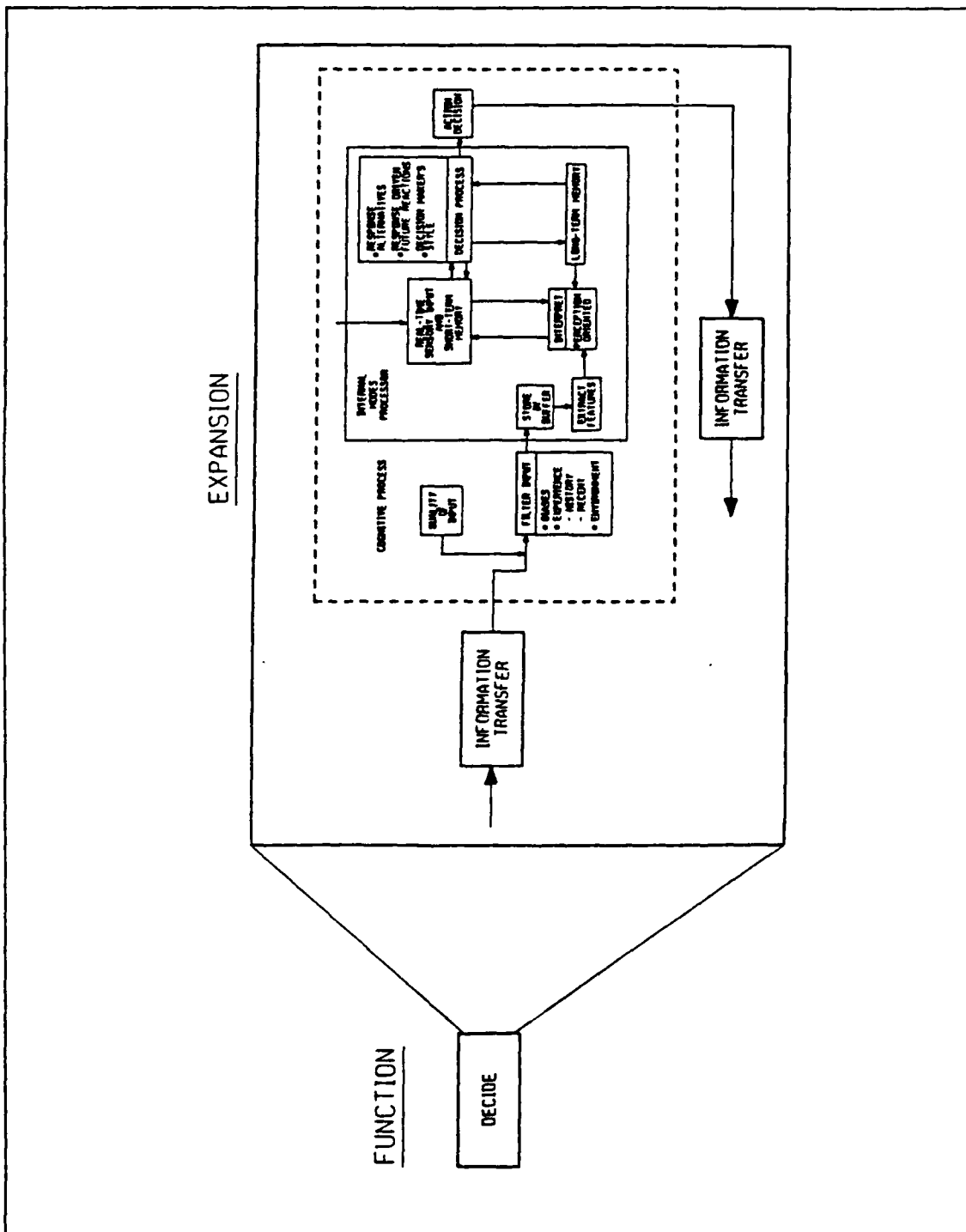

Figure 4. Metersky's Decide Expansion

other tactical decision aids, such as Link 11, which can assist the decisionmaker in his duties.

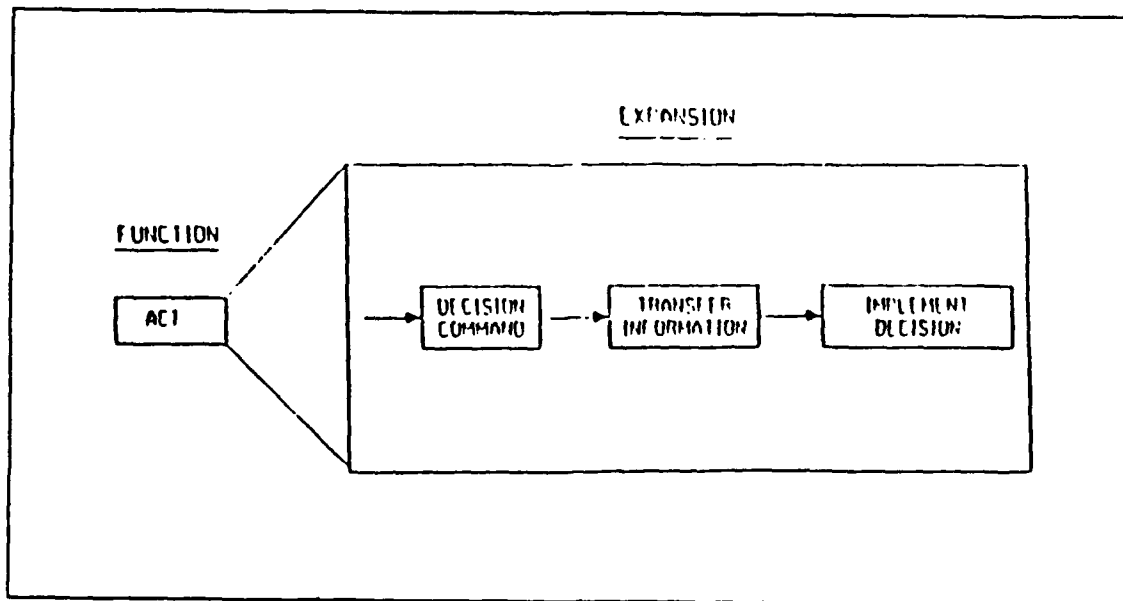

Figure 5. Metersky's Act Expansion

The last expanded function is *act* as shown in Figure 5. The subfunction *decision command* is the translation of a decision into observable actions. The second subfunction *implement decision* ". . . concerns the procedures taken to effect the decision" (Metersky, 1986, 885).

Figure 6 on page 13 combines all the functions and subfunctions into a whole. He perceives several advantages to his model which include the recognition of humans being involved in the process and identification of specific information transfer requirements between the various functions and subfunctions. Information transfer is specifically shown in various places on Figure 6. (Metersky, 1986, 887)

### 3. Where does the human fit in?

Command and control processes, when implemented, can vary from the fully automated such as one proposal for the Strategic Defense Initiative to the fully manual such as the lone rifleman stalking a target. Most implemented processes or systems fall somewhere in between.

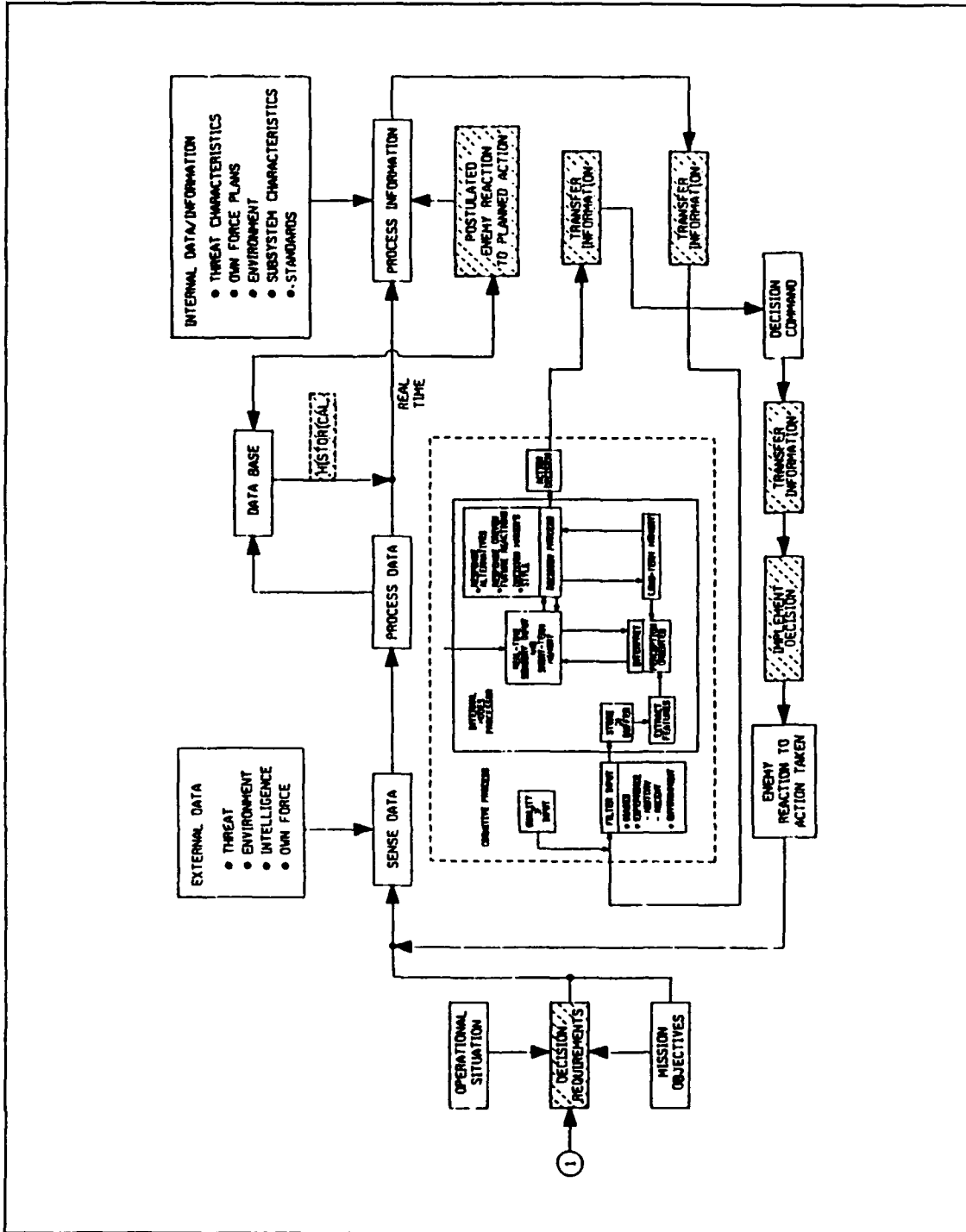

Figure 6. Metersky's C2 Process Model

The system should support the decision and action functions of the decisionmaker in the partially automated C2 system. To do this, consideration should be given to the information value judgments of the system user. This can be done through decision analysis methods as discussed earlier or through the method proposed in Chapter Three.

### **C. CURRENT DATA LINK CONFIGURATION MANAGEMENT**

The Navy Joint Interoperability of Tactical Command and Control Systems (JINTACCS) Configuration Management Plan (NJCMP) Revision 1 dated 11 August 1987:

... details the initiation, processing, analysis, testing, approval, implementation, and status accounting procedures needed to control and maintain JINTACCS message standard baseline and operating procedures within the Navy. The JINTACCS program includes standards for:

- a. Joint Tactical Air Operations (JTAO) (Link 11, 4A, and 14).
- b. U.S. Message Text Formats (USMTF).
- c. Tactical Digital Information Link (TADIL) J standards for the Joint Tactical Information Distribution System (JTIDS) (NTISA, 1987, promulgation letter).

This section outlines the means by which a hypothetical change proposal would be evaluated under the existing configuration management (CM) procedures as described in the NJCMP.

Configuration management under the JINTACCS program includes these basic elements. *Configuration identification* is the specific documentation which supports a particular configuration item. It consists of operational specifications, technical design plans or related JCS documents and will be maintained throughout the lifecycle of the CI. *Configuration control* is comprised of three parts:

- formal processing of applicable change proposals
- actual processing and evaluation of the change proposals
- implementation of approved change proposals into the configuration item.

These JINTACCS CM elements are incorporated into Navy configuration management.

The Navy Tactical Interoperability Support Activity (NTISA) is the CNO's primary technical advisor for configuration control of the JINTACCS baseline.

NTISA performs this function through the Operational Interoperability Requirements Group (OIRG) and the Technical Interoperability Standards Group (TISG). The former group "is composed of representatives from the operating forces (Fleet CINCs, type commanders, and Commander, Naval Intelligence Command (COMNAVINTCOM)) "(NTISA, 1987, 3-2). The latter group is primarily responsible for technical aspects of the CIs, including maintenance of the various operational specifications. Its members include representatives from the various "software development and life-cycle support activities for the various tactical data system programs"(NTISA, 1987, 3-2).

### **1. A Configuration Management Example**

Lieutenant Mary Smith is the Tactical Action Officer aboard the USS CARMEL, a Link 11-capable destroyer assigned to Second Fleet. In the performance of her duties, she observes existing procedures for assignment of the Net Control Station in the data link do not adequately consider radio equipment capabilities of the assigned platform. She believes an algorithm which considers equipment status of the proposed NCS would allow for better performance of the data link within the battle group. After creating an algorithm that considers equipment status, she drafts a change proposal recommending implementation of her algorithm and forwards it to Commander, Second Fleet, who is a primary command in the OIRG, via the administrative chain of command. Second Fleet staff assigned to review the proposal believe the proposed algorithm is a valid inclusion for Link 11 and forward the proposal to NTISA for status accounting. Second Fleet assigned the change proposal a characteristic of Proposed Operational Requirement, since the current procedure, although not as effective as LT Smith's algorithm, is functioning well enough to meet their operational requirements.

Upon receipt of the Proposed Operational Requirement (POR) from Second Fleet, NTISA will assign it an agenda item number for the next biannual meeting of the OIRG. It will also be assigned a POR number which

. . . will be composed of the functional area affected by the POR, followed by a sequential number relative to all PORs proposed in that functional area, followed by the calendar year in which the POR was drafted (not necessarily the year in

which originated by the source. Example: ASW-2-79 is the second ASW POR drafted in CY-79). TADIL functional areas are "AAW", "ASW", "ASUW", "EW", or "OPS" (NTISA, 1987, 7-3).

This POR number allows for status accounting of the change proposal as it makes its way through the configuration management process.

NTISA collects all agenda items and provides a complete package to each of the OIRG participants at least ten weeks prior to the next scheduled OIRG. Each participant reviews the agenda items and staffs them with subordinate commands as necessary to come up with a command position on each item. No procedures are in the NJCMP for the method to be used by the participants in doing their internal staffing of agenda items.

At the OIRG meeting, each agenda item will be considered in turn by the body. Items may be agreed upon by the group with one of five dispositions:

1. Agree with the proposal as written.
2. Agree with the item as amended by the group.
3. Disapprove the item.
4. Continue the item to the next meeting.
5. Withdraw the item at the request of the originator.

If unanimous agreement cannot be reached on the agenda item, the Chair can rule directly on the item and record the dissenting opinions, create a working group to attempt resolution, continue the item to the next meeting or some other specified date or declare the issue to be substantive, which would require special procedures for resolution. (NTISA, 1987, B-4, 5)

If the OIRG determines the POR is of value and approves it, the agenda item will be passed to the TISG for action. The TISG reviews the item on its technical merit and determines its implementation schedule and cost. They use a method similar to the one used by the OIRG. After the schedule and cost are delineated, the item is forward to the CNO for approval. NTISA will continue to monitor the progress of the agenda item through its implementation, after which the item will become a part of the configuration baseline.



#### **D. PUTTING IT ALL TOGETHER**

The previous sections discuss the command and control process and imply that information within the process has a certain value to the tactical decisionmaker. If this is the case, one would assume information value would be an integral part of the Navy CM process. Unfortunately, you will note the configuration management process as outlined in the NJCMP, a hypothetical example of which was given, does not explicitly include a method for subjective evaluation of the value of information content in the data link. The next chapter describes an explicit method for incorporating these subjective views.

### **III. INCORPORATING THE DELPHI METHOD INTO CONFIGURATION MANAGEMENT**

This chapter discusses the Delphi method and gives the author's views on how it can be incorporated into existing Navy configuration management processes.

#### **A. THE DELPHI METHOD**

Delphi has come a long way in its brief history, and it has a long way to go. Since its invention . . . for the purpose of estimating the probable effects of a massive atomic bombing attack on the United States, and its subsequent application in the mid-sixties to technological forecasting, its use has proliferated in the United States and abroad. While its principal area of application has remained that of technological forecasting, it has been used in many other contexts in which judgmental information is indispensable (Linstone and Turoff (eds.), 1975, xix).

##### **1. History**

The Delphi technique was developed during the early 1950's for use in Rand Corporation's study of the "application of 'expert opinion to the selection, from the point of view of a Soviet strategic planner, of an optimal U. S. industrial target system and to the estimation of the number of A-bombs required to reduce the munitions output by a prescribed amount.'" This original study, sponsored by the Air Force, was titled "Project Delphi". Developed during this study specifically as a long-range forecasting tool, Delphi has crept beyond military boundaries and is now used extensively in the private sector for numerous applications.

##### **2. Method of use**

Several different variants of the Delphi technique have been established. This discussion will focus on what Linstone and Turoff (1975) refer to as the "Conventional" approach. They view Delphi ". . . as a method for structuring a group communication process so that the process is effective in allowing a group of individuals, as a whole, to deal with a complex problem" (Linstone and Turoff (eds.), 1975, 3). This process allows for direct communication of individual ideas and feedback of those ideas to other participants.

assimilation of a group position, ability for an individual to revise his or her views and some amount of anonymity among the participants. These features eliminate some of the negative aspects of group decisionmaking such as " . . . conflict, disagreement, and misunderstanding among group members-- [which] are regarded as products of the inability of individuals to process information consistently and to understand the positions taken and judgments made by other members about decision issues "(Guzzo (ed.), 1982, 9).

The Delphi procedure is comprised of various *rounds* which consist of participants completing a questionnaire about the issues which are to be decided upon. The participant is usually given two copies of the questionnaire and is asked to fill out both but return only one. After the questionnaires are returned to the *supervisor* they are collated into a group position. On the successive rounds, this group position is provided to the participants in addition to the next questionnaire. Several methods are available to the supervisor to use in forming the group position from the individual questionnaires, but they are beyond the scope of this study. At any time during the rounds, an individual with an extreme position is asked to give reasons for the answers given. These answers may also be provided to the other participants during later rounds. After the selected number of rounds or when the supervisor determines a group position has been reached, the Delphi concludes. Each participant is provided a summary of the final conclusions.

### **3. Drawbacks and Criticisms**

As outlined, the Delphi appears fairly straightforward in its application. However, there is a significant overhead burden to the supervisor and his team in collecting all the answers and redistributing them to the participants. Also, the construction of questions for the Delphi is difficult since the supervisor should not attempt to influence the choices of the participants. The journal *Technological Forecasting and Social Change* gives many examples of Delphi applications which show adequate consideration of the former.

The method is not without its critics, one of the most vocal of whom is affiliated with the "fountain of knowledge": the Rand Corporation. Sackman (Rand, 1974) criticized the Delphi on two major fronts, the first of which was

[i]f Delphi is to be treated seriously as a professional technique, it must be judged by basic, minimum standards applicable to all empirical social sciences (Rand, 1974, 11).

He refers primarily to the American Psychological Association's evaluative criteria established to inculcate scientific procedures into a field which had a long history of abuses on the part of test administrators and other researchers (Rand, 1974, 9). His second criticism was the questionable application of the technique by some researchers who disregarded basic points such as sample size, questionnaire construction and reliability of their research. He continues that evaluative judgments made from improperly constructed Delphi are suspect. (Rand, 1974, 28-68)

After Sackman's critique, almost a complete issue of *Technological Forecasting and Social Change*, the leading journal for Delphi research, was devoted to contradicting arguments (7, 127-233, 1975). The result of this debate appeared to confirm Sackman is correct on his first point but incorrect on the second. This debate, although more than ten years ago, should influence the application of any Delphi. Commentary on dissertations using the Delphi method indicate all researchers are not as thorough as they should be in the application of the Delphi (Rieger, 1986, 201).

## **B. HOW IT CAN BE USED BY NTISA**

The author proposes a modification of Turoff's Policy Delphi as a preparation technique for use in the configuration management process. The technique's use, as proposed, will not eliminate the need for the existing face-to-face meetings but is intended to standardize the participants' preparation and focus on explicit consideration of the impact of the proposed changes on the human decisionmaker. The goal of including this method as a preparation technique is not for the CM body to evaluate the method by which they reach a decision on a particular configuration item. It is more the subjective

assessments of the participants regarding the information value of the CI in question. Turoff describes six steps in the communication process of his Policy Delphi. They are:

1. Formulation of the issues. What is the issue that really should be under consideration? How should it be stated?
2. Exposing the options. Given the issue, what are the policy options available?
3. Determining initial position on the issues. Which are the ones everyone already agrees upon and which are the unimportant ones to be discarded? Which are the ones exhibiting disagreement among the respondents?
4. Exploring and obtaining the reasons for disagreements. What underlying assumptions, views, or facts are being used by the individuals to support their respective positions?
5. Evaluating the underlying reasons. How does the group view the separate arguments used to defend various positions and how do they compare to one another on a relative basis?
6. Reevaluating the options. Reevaluation is based upon the views of the underlying "evidence" and the assessment of its relevance to each position taken. (Linstone and Turoff (eds.), 1975, 88)

Each of these six points should be kept in mind when reading the following.

Upon receipt of the agenda items proposed for the next OIRG or TISG meeting NTISA will prepare a series of questions relating to each agenda item's possible impact on the data link. Possible questions are included in a 1979 report by Applied Decision Analysis titled *An Analytic Characterization of Navy Command and Control Decisions*. Example questions from the Applied Decision Analysis report and the rating scales suggested by Turoff are included at the Appendix. The primary and alternate commands would receive these questions with the agenda item package. The questionnaire is accompanied by instructions such as those of Jones (1978, 99-155). Additionally, the participants are instructed they may consult with any member of their subordinate staff in determining their answers but the original participant command representative should complete the questionnaire.

After the initial round, the questionnaires will be returned to NTISA where they will be compiled. The author recommends that opinions which are away from the norm be included in the compiled product along with the reasons

given for the answer by the participant. Following Jones, the second round asks for further elicitation of the issues. The results of the first round are included with the questionnaire and other materials for the second round. The third round would follow the same general procedure with the exception of the results being provided to the participants at the scheduled OIRG or TISG meeting. By this point, the participants will be clear on the issues involved and also be aware of conflicting views.

The author suggests this method not be used directly for issues involving technical design standards such as how to represent a proposed message in octal coding but that it be reserved for review of issues which affect the human interface to the data link. These issues could range from the determination of effects from changing an existing message field to discerning the operational impact of a change proposal to Standard Operating Procedures. The focus should be on improving the utility of the data link from the perspective of the decisionmaker.

Turoff suggests a three or four round Delphi may be sufficient if the supervisory team devotes a considerable amount of time formulating the questionnaire to include all obvious issues, allows participants to add issues to the initial list and asks for a position, with the participant's reasons for the position, on the first round. (Linstone and Turoff (eds.), 1975, 88-92)

#### **IV. IMPLICATIONS IN USING THE DELPHI**

The considerations that enable good decisionmaking remain the same regardless if the decisionmaker is a corporate executive faced with a problem in production or a military commander faced with a tactical decision. Each has a responsibility to analyze the problem and make a decision that will affect the welfare of the organization (Combined Arms and Services Staff School, 1984. 1).

As noted in the quotation above, the military commander's decisionmaking responsibilities are to analyse the problem and make a decision. In Chapter Two, relevant concepts of decision theory were discussed. One primary concept was the inherent value of information to the decisionmaker. Chapter Three described a method for incorporating information value in CM decisions. This chapter discusses implications of using the Delphi method to include information value judgments into the CM process.

##### **A. BETTER SUPPORT FOR THE TACTICAL DECISIONMAKER**

As discussed in the section on command and control processes, there is often little consideration given to the "man in the loop" by command and control system designers. This often results in systems which do not meet the needs of the user. By including a method explicitly requiring consideration of the human, the human's information needs will more likely be met. This point is emphasized by Metersky and Ryder (undated. 2) who state "[f]or effective task performance, the information displayed must be relevant to the operator's needs." When the decisionmaker's need for information is met you may conclude the mission performance of the unit to which the decisionmaker is assigned will improve.

##### **B. IMPROVED CONFIGURATION MANAGEMENT**

The existing CM process does not allow for a methodical evaluation of non-quantitative issues. As a result, much time is spent trying to determine the heuristics on which individuals base their CM votes. Through selective use of the Delphi the OIRG and TISG can spend more time in preparation for their respective meetings with less time debating minor points and arguing

over such things as meanings of words during the meeting. Use of the Delphi should also remove some of the obstacles inherent in group meetings as discussed earlier. Implementation of the Delphi should result in a more rapid treatment of agenda items and subsequently, sooner implementation into the data links.



## **V. CONCLUSIONS AND RECOMMENDATIONS**

The author concludes that insufficient emphasis has been placed on the human's role in the command and control process. The primary focus has been on hardware and software since those items can be seen and touched. As a consequence, little emphasis is put on the information needs of the tactical decisionmaker in existing C2 systems which are ostensibly designed to support him. Various methods, including the Delphi, have been developed to gather and evaluate expert opinions on subjects which defy quantification through existing statistical methods. However, these methods are not being used in the Navy CM process. Incorporating methods such as the Delphi would improve the effectiveness of a C2 system by considering the information needs of the human user in its design. This inclusion should result in increased effectiveness of the tactical unit.

### **A. RECOMMENDATIONS**

Consideration should be given to modifying the existing CM procedures to include the modified Policy Delphi method as outlined in Chapter Three. Alternatively, if the Delphi is not included, NTISA may wish to use the analysis method outlined in the paper by Applied Decision Analysis (1979) to guide the agenda item discussions of the OIRG and TISG. Both methods would force the consideration of the human's information needs.

The author proposes other research to create a Delphi for use in the CM process described in this study. This Delphi would include actual configuration items under consideration and build on the techniques outlined in Chapter Three. Subsequent analysis could include polling the participants' opinions on the execution of the method and comparative studies between Delphi-preparation and non-Delphi-preparation agenda items regarding ease of reaching group consensus at the OIRG/TISG meeting.

A second area for further study would be to create a simulation program for use by NTISA to evaluate independently a proposed change to the data

link. This program would require the isolation of the proposed change as the independent variable and would require almost full implementation of the data link standard into the simulation. The simulation results could be used by the OIRG in evaluating operational impact of a proposed change and the TISG could use it as a method to determine technical feasibility of a change.

## APPENDIX A. EXAMPLE QUESTIONS

1. How much time is available for the decision? This is the time from recognition of a decision to the point where an action must be taken.
  - Less than one minute
  - One minute to one hour
  - One hour to one day
  - One day to one month
  - Greater than one month
2. What is the frequency of the decision? What is the mean time between recurrence of the decision?
  - Less than ten minutes
  - Ten minutes to ten hours
  - Ten hours to one month
  - One month to one year
  - Greater than one year
3. What is the quantity of information relating to a decision received by a decisionmaker and his staff, in terms of the number of bytes per day (or a Shannon information measure per unit time)?
  - Less than ten
  - Ten to 100
  - Greater than 100
4. What percentage of messages is significantly more valuable than the average?
  - Zero to one percent
  - One to ten percent
  - More than ten percent
5. How reliable are the information sources? What percentage of the information sources are considered reliable?
  - Less than forty percent
  - Forty to sixty percent
  - Sixty to eighty percent
  - More than eighty percent

## APPENDIX B. TUROFF'S POLICY DELPHI SCALES

**Turoff's Policy Delphi Scales**

IMPORTANCE (PRIORITY OR RELEVANCE)	DESCRIPTIVE GUIDELINES
Very important	<ul style="list-style-type: none"> <li>• A most relevant point</li> <li>• First-order priority</li> <li>• Has direct bearing on major issues</li> <li>• Must be resolved, dealt with, or treated</li> </ul>
Important	<ul style="list-style-type: none"> <li>• Is relevant to the issue</li> <li>• Second-order priority</li> <li>• Significant impact but not until other items are treated</li> <li>• Does not have to be fully resolved</li> </ul>
Slightly important	<ul style="list-style-type: none"> <li>• Insignificant</li> <li>• Third-order priority</li> <li>• Has little importance</li> <li>• Not a determining factor to major issue</li> </ul>
Unimportant	<ul style="list-style-type: none"> <li>• No relevance</li> <li>• No priority</li> <li>• No measurable effect</li> <li>• Should be dropped as an item to consider</li> </ul>

**Turoff's Policy Delphi Scales (continued)**

<b>CONFIDENCE (IN VALIDITY, ARGUMENT OR PREMISE)</b>	<b>DESCRIPTIVE GUIDELINES</b>
Certain	<ul style="list-style-type: none"> <li>• Low risk of being wrong</li> <li>• Decision based upon this will not be wrong because of this "fact"</li> <li>• Most inferences drawn from this will be true</li> </ul>
Reliable	<ul style="list-style-type: none"> <li>• Some risk of being wrong</li> <li>• Willing to make a decision based on this but recognizing some chance of error</li> <li>• Some incorrect inferences can be drawn</li> </ul>
Risky	<ul style="list-style-type: none"> <li>• Substantial risk of being wrong</li> <li>• Not willing to make a decision based on this alone</li> <li>• Many incorrect inferences can be drawn</li> </ul>
Unreliable	<ul style="list-style-type: none"> <li>• Great risk of being wrong</li> <li>• Of no use as a decision basis</li> </ul>

**Turoff's Policy Delphi Scales (continued)**

<b>DESIRABILITY (EFFECTIVENESS OF BENEFITS)</b>	<b>DESCRIPTIVE GUIDELINES</b>
Very desirable	<ul style="list-style-type: none"> <li>• Will have a positive effect and little or no negative effect</li> <li>• Extremely beneficial</li> <li>• Justifiable on its own merit</li> </ul>
Desirable	<ul style="list-style-type: none"> <li>• Will have a positive effect, negative effects minor</li> <li>• Beneficial</li> <li>• Justifiable as a by-product or in conjunction with other items</li> </ul>
Undesirable	<ul style="list-style-type: none"> <li>• Will have a negative effect</li> <li>• Harmful</li> <li>• May be justified only as a by-product of a very desirable item, not</li> <li>• justified as a by-product of a desirable item</li> </ul>
Very undesirable	<ul style="list-style-type: none"> <li>• Will have a major negative effect</li> <li>• Extremely harmful</li> <li>• Not justifiable</li> </ul>

**Turoff's Policy Delphi Scales (continued)**

PROBABILITY (LIKELIHOOD)	DESCRIPTIVE GUIDELINES
Very probable	<ul style="list-style-type: none"> <li>• Almost certain to occur</li> <li>• Strong indication of this happening</li> </ul>
Probable	<ul style="list-style-type: none"> <li>• Better than a 50-50 chance of occurring</li> <li>• Some indications of this happening</li> </ul>
Either way	<ul style="list-style-type: none"> <li>• About 50-50</li> <li>• Could go either way</li> </ul>
Improbable	<ul style="list-style-type: none"> <li>• Less than a 50-50 chance of occurring</li> <li>• Some indications of this not happening</li> </ul>
Very improbable	<ul style="list-style-type: none"> <li>• Almost certain not to occur</li> <li>• Strong indications against this happening</li> </ul>

**Turoff's Policy Delphi Scales (continued)**

<b>FEASIBILITY (PRACTICALITY)</b>	<b>DESCRIPTIVE GUIDELINES</b>
Definitely feasible	<ul style="list-style-type: none"><li>• No hindrance to implementation</li><li>• No R&amp;D required</li><li>• No political roadblocks</li><li>• Acceptable to the public</li></ul>
Possibly feasible	<ul style="list-style-type: none"><li>• Some indications this is implementable</li><li>• Some R&amp;D required</li><li>• Further consideration or preparation to be given to political or public reaction</li></ul>
Definitely infeasible	<ul style="list-style-type: none"><li>• All indications are negative</li><li>• Unworkable</li><li>• Cannot be implemented</li></ul>



## LIST OF REFERENCES

Applied Decision Analysis, Inc.. Final Report. *An Analytic Characterization of Navy Command and Control Decisions*, by A. C. Miller III, T. R. Rice, and M. R. Metcalfe, March 1979.

Telephone conversation between Dennis Bennett, NTISA San Diego, and the author, 12 February 1989.

Combined Arms and Services Staff School, Ft. Leavenworth, KS, *E104 Military Decisionmaking*, privately printed, May 1984.

Hammond, K. R., McClelland, G. H., and Mumpower, J., *Human Judgment and Decision Making*, Praeger Publishers, 1980.

Guzzo, R. A., ed., *Improving Group Decision Making in Organizations*, Academic Press, 1982.

Jones, W. O., *The Determination of Future User Requirements for an Existing Management Information System Using a Delphic Methodology*, Doctoral Dissertation, University of Georgia, 1978.

Lawson, J. S., "The State Variables of a Command Control System," *Proceedings for Quantitative Assessment of the Utility of Command and Control Systems*, National Defense University, Washington, DC, January 1980.

Linstone, H. A. and Turoff, M., eds., *The Delphi Method: Techniques and Applications*, Addison-Wesley Publishing Company, 1975.

Metersky, M. L., "A C2 Process and an Approach to Design and Evaluation," *IEEE Transactions on Systems, Man, and Cybernetics*, v. SMC-16, no. 6, November/December 1986: 880-889.

Metersky, M. L. and Ryder, J. M., "A Change in System Design Emphasis: From Machine to Man," unpublished paper, Naval Air Development Center, Warminster, PA, no date, photocopied.

Navy Tactical Interoperability Support Activity, San Diego, CA, *Navy Joint Configuration Management Plan*, issued by direction of the Chief of Naval Operations, 11 August 1987.

Rand Corporation, Report R-1283-PR, *Delphi Assessment: Expert Opinion, Forecasting, and Group Process*, by H. Sackman, April 1974.

Rieger, W. G.. "Directions in Delphi Developments: Dissertations and Their Quality." *Technological Forecasting and Social Change*, v. 29. 1986: 195-204.

*Technological Forecasting and Social Change*, v. 7, 1975: 127-233.

U. S. Joint Chiefs of Staff. *Department of Defense Dictionary of Military and Associated Terms*. (JCS Publication 1), U. S. Government Printing Office, 1987.

## BIBLIOGRAPHY

Alphatech, Inc. Report TR-137. *Modeling Human Decision Processes in Command and Control*, by J. G. Wohl, E. E. Entin, and J. S. Eterno, January 1983.

Alphatech, Inc., Report R-151, *Toward a Unified Approach to Combat System Analysis*, by J. G. Wohl and others, January 1983.

Cooper, W. S., "Decision Theory as a Branch of Evolutionary Theory: A Biological Derivation of the Savage Axioms," *Psychological Review*, v. 94, no. 4, 1987: 395-411.

Cundiff, W. C., "Interactive Software for the Capture, Management, and Analysis of Data in DELPHI Inquiries: Defined Functions in APL," *Technological Forecasting and Social Change*, v. 34, 1988: 189-195.

Decisions and Designs, Inc., McLean, VA. *Decision Theory Research*, by C. W. Kelly, C. R. Peterson and R. V. Brown, April 1975.

Dietz, T., "Methods for Analyzing Data from Delphi Panels: Some Evidence From a Forecasting Study," *Technological Forecasting and Social Change*, v. 31, 1987: 79-85.

Grossberg, S. and Gutowski, W. E., "Neural Dynamics of Decision Making Under Risk: Affective Balance and Cognitive-Emotional Interactions," *Psychological Review*, v. 94, no. 3, 1987: 300-318.

Institute for Defense Analysis, Program Analysis Division, IDA Paper P-1355, *Decision Modeling in Large Scale Conflict Simulations*, by L. B. Anderson, October 1978.

Klahr, P. and Waterman, D. A., eds., *Expert Systems Techniques. Tools and Applications*, Addison-Wesley Publishing Company, 1986.

Michie, D., ed., *Introductory Readings in Expert Systems*, Studies in Cybernetics, ed. F. H. George, v. 1, Gordon and Breach Science Publishers, 1982.

Navy Personnel Research and Development Center, NPRDC-TN 88-12, *Brain Activity During Tactical Decision-Making: II. Probe-Evoked Potentials and Workload*, by L. J. Trejo, G. W. Lewis and M. H. Blankenship, December 1987.

Naval Postgraduate School, Monterey, CA, NPS-55-80-027, *Models that Reflect the Value of Information in a Command and Control Context*, by D. P. Gaver, October 1980.

Naval Postgraduate School, Monterey, CA. TAEG Report No. 27. *Decision Analysis and its Application to the Naval Education and Training Command*. by W. C. Giaouque, July 1975.

Nelms, K. R. and Porter, A. L., "EFTE: An Interactive Delphi Method," *Technological Forecasting and Social Change*, v. 28, 1985: 43-61.

Nutt, P. C., "Decision Style and Its Impact on Managers and Management," *Technological Forecasting and Social Change*, v. 29, 1986: 341-366.

Sweet, R., Metersky, M., and Sovereign, M., "Command and Control Evaluation Workshop." Military Operations Research Society C2 MOE Workshop, Naval Postgraduate School, Monterey, CA, January 1985, photocopied.

Tversky, A., Slovic, P. and Sattath, S., "Contingent Weighting in Judgment and Choice." *Psychological Review*, v. 95, no. 3, 1988: 371-384.

### INITIAL DISTRIBUTION LIST

	No. Copies
1. Defense Technical Information Center Cameron Station Alexandria, VA 22304-6145	2
2. Library, Code 0142 Naval Postgraduate School Monterey, CA 93943-5002	2
3. Commander Naval Air Development Center attn: Dr. Metersky Warminster, PA 18974-5000	1
4. Commanding Officer Navy Tactical Interoperability Support Activity 200 Catalina Boulevard San Diego, CA 92147-5082	2
5. Commanding Officer Fleet Combat Direction Systems Support Activity, San Diego 200 Catalina Boulevard San Diego, CA 92147-5081	1
6. Commanding Officer Fleet Combat Direction Systems Support Activity, Dam Neck Virginia Beach, VA 23461-5300	1
7. Commanding Officer Fleet Combat Training Center, Pacific San Diego, CA 92147-5082	1
8. Commanding Officer Fleet Combat Training Center, Atlantic Dam Neck Virginia Beach, VA 23461-5200	1
9. Commanding Officer Navy Recruiting District, Houston attn: LT Ketcham 1121 Walker Street, 9th Floor Houston, TX 77002-6429	1

- |     |  |   |  |
|-----|--|---|--|
| 10. | Commander<br>Naval Ocean Systems Center<br>attn: LT N. McClelland<br>San Diego, CA 92152-5000        | 1 |  |
| 11. | Commanding Officer<br>Navy Personnel Research and Development Center<br>San Diego, CA 92152-6800     | 1 |  |
| 12. | Superintendent<br>Naval Postgraduate School<br>Code 55Mi<br>Monterey, CA 93943-5002                  | 2 |  |
| 13. | Superintendent<br>Naval Postgraduate School<br>Code 52Yu<br>Monterey, CA 93943-5002                  | 2 |  |
| 14. | Director for Command, Control and Communications Systems<br>Joint Staff<br>Washington, DC 30218-6000 | 1 |  |
| 15. | Superintendent<br>Naval Postgraduate School<br>Code 74, C3 Academic Group<br>Monterey, CA 93943-5000 | 1 |  |