

AD-A287 495

READOUT AND SIGNAL CONDITIONING FOR A LINEAR
DIELECTRIC ARRAY (U) ROYAL SIGNALS AND RADAR
ESTABLISHMENT MALVERN (ENGLAND) F A MANNING AUG 88
RSRE-MERO-4102 DRIC-BR-189769

1/1

UNCLASSIFIED

F/G 17/3.1 ML

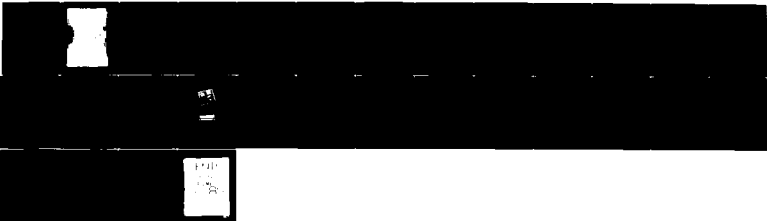

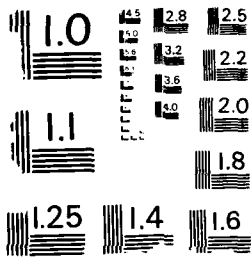

AD-A207 495

0036828

CONDITIONS OF RELEASE

BR-109769

.....

U

COPYRIGHT (c)
1988
CONTROLLER
HMSO LONDON

.....

Y

Reports quoted are not necessarily available to members of the public or to commercial organisations.

ROYAL SIGNALS AND RADAR ESTABLISHMENT

Memorandum 4102

TITLE: READOUT AND SIGNAL CONDITIONING FOR
A LINEAR PYROELECTRIC ARRAY

AUTHOR: P A Manning

DATE: August 1988

SUMMARY

A pyroelectric infrared detector and associated components are described which together make up an uncooled infrared sensor system. The prototype system is low cost, has low power consumption, and has a sensitivity of better than 0.25K.

Accession For	
NTIS (CRAS)	<input checked="" type="checkbox"/>
DTIC TAB	<input type="checkbox"/>
Unannounced	<input type="checkbox"/>
Justification	
By	
Distribution/	
Availability Codes	
Dist	Avail and/or Special
A1	

Copyright
©
Controller HMSO London
1988

THIS PAGE IS LEFT BLANK INTENTIONALLY

RSRE MEMORANDUM 4102

READOUT AND SIGNAL CONDITIONING FOR A LINEAR PYROELECTRIC ARRAY

P A Manning

LIST OF CONTENTS

- 1 Introduction
- 2 Sensor Design
 - 2.1 Sensor configuration
 - 2.2 Optics module
 - 2.2.1 Infrared detector array
 - 2.2.2 Low-noise power conditioning
 - 2.2.3 Chopper assembly
 - 2.3 Electronics module
 - 2.3.1 Power supply
 - 2.3.2 Analogue processor
 - 2.3.3 Image difference processor
 - 2.3.4 Mean scene processor
 - 2.3.5 Chopper control and data output
- 3 Image Display
 - 3.1 Data receiver
- 4 System Performance
 - 4.1 Performance prediction
 - 4.2 Measured performance
- 5 Discussion
- 6 Conclusion
- Acknowledgements
- References

LIST OF FIGURES

- 1 Sensor Block Diagram
- 2 Optics Module Schematic
- 3 Detector Array: physical
- 4 Detector Array: schematic
- 5 Focal Plane Chopper
- 6 Analogue Processing Schematic
- 7 IDP Schematic
- 8 Mean Scene Processor Schematic
- 9 Typical Detector Responsivity
- 10 Typical Detector Noise

LIST OF APPENDICES

- 1 Focal Plane Chopping
- 2 Circuit Diagrams

THIS PAGE IS LEFT BLANK INTENTIONALLY

1 INTRODUCTION

The requirement for low-cost infrared sensors for a range of applications has led to the development of linear pyroelectric detector arrays of up to 64 elements, integrated with MOSFET readout electronics and low-microphony packaging to give compact and easy-to-use infrared detectors operating at ambient temperatures in the 8-14 micron waveband. Along with these detectors, the necessary signal conditioning techniques have been developed, in order that the best system performance can be obtained whilst maintaining the aims of low cost, low power, and small size.

The sensor system described here uses the VX 8-647 detector, developed under DCVD contract at Philips Components Ltd⁽¹⁾. This detector is a 64 element ceramic pyroelectric array, with fully reticulated elements and with thermal and vibration isolation by means of a membrane structure⁽²⁾. A custom MOSFET readout chip and standard hybrid components within the detector package make interfacing to the detector array very straightforward. The signal conditioning electronics is designed to be low power at low cost, making maximum use of analogue and digital CMOS components. The sensor is configured to be battery powered and transmit data by means of a serial data link. A measured NEDT of 0.25K at 50 Hz line rate is achieved, which accords well with the theoretical predictions^(3,4).

2 SENSOR DESIGN

2.1 SENSOR CONFIGURATION

The prototype sensor system is configured mechanically as two modules; an optics module containing the germanium lens, the detector array, the chopper mechanism, and a low-noise power supply circuit board; and an electronics module containing the signal conditioning electronics, power supply, chopper controller and data link driver (Figure 1). The two modules are connected by a multiway cable which carries synchronisation signals and power supplies from the electronics module to the optics module, and carries analogue signals to the electronics module. System power is provided by a 12 Volt DC input, and signal output is provided by means of a digital serial data link available as a differentially driven pair, or an optical fibre output.

2.2 OPTICS MODULE

The optics module takes the form of a small metal box 110 mm x 70 mm x 80 mm with a lens mount incorporated. The lens focuses radiation on to the detector focal plane, where it is modulated by a thin blackened metal chopper which is driven by a small low-power DC motor. The position of the chopper blade is sensed by means of a slotted optical switch, enabling the chopper phase to be controlled with respect to the detector readout (Figure 2).

2.2.1 Infrared Detector Array

The VX 8647 was designed to be a high performance linear detector array operating in the 8-14 micron waveband over the military temperature range (-40° to +70°C). It is a rugged detector with low microphony and it has proved possible to manufacture stage A examples of this detector with extremely good uniformity of signal response ($\pm 3\%$)⁽¹⁾.

The detector array consists of 64 pyroelectric ceramic detector elements at 100 microns pitch (Figures 3,4). Each radiation-sensitive element is connected in parallel opposition with an identical element which has a reflecting rather than radiation-absorbing layer on the surface, and so acts as a compensating element for changes in ambient temperature and microphony.

Each of these pairs of detector elements is coupled to a MOSFET source follower and a multiplexer switch on a custom silicon integrated circuit, which is wire-bonded to the detector array. The detector element to be read out is selected by a 6-bit binary word applied to the detector. The signal from the multiplexer is amplified with a gain of 10x, thus minimising the effect of noise from subsequent stages of processing.

2.2.2 Low-Noise Power Conditioning

Due to the very poor power supply noise rejection ratio of the detector array (8 dB on -2.5 V supply) to the analogue power rails (± 2.5 V)⁽¹⁾, a small power supply conditioning PCB is included close to the detector in the optics module. This consists of a pair of low noise bandgap references, the output from which is filtered and amplified to yield the low-noise power supplies (Circuit 1).

2.2.3 Chopper Assembly

The focal plane chopper used to modulate the incoming radiation is mounted directly on to the shaft of a small DC rotor (Escap 16M11205). The chopper is a twin spiral blade design, giving a rotor speed of 1500 rpm for a 50 Hz line rate. The spiral edges are defined by the equation

$$r = r_0 + \frac{2\theta\ell}{\pi}$$

where r is the instantaneous radius, r_0 is the radius to the centre of the array, ℓ is the length of the array and θ the angle in radians from the spiral midpoint. Segments are provided to give sharp interruption for a slotted optical pick-off to sense chopper phase, giving a total diameter of 55 mm (Figure 5). The optical pick-off consists of a LED/phototransistor pair in a slotted housing. The chopper interrupts the light path between the LED and phototransistor enabling the passage of a blade edge to be sensed.

2.2.4 Lens

The lens mount on the prototype imager is a standard "Wreathall" mount, commonly used for IR lenses for pyroelectric vidicon cameras. The lens selected for most of the laboratory work is a Dalmeyer f0.8 25 mm focal length germanium lens.

2.3 ELECTRONICS MODULE

The electronics module connects to the optics module via a multiway cable; providing power and clock waveforms for the detector, controlling the chopper phase, and receiving the analogue detector output. The module contains five small eurocards 100 x 160 mm comprising:

- i. power supply,
- ii. analogue processor,
- iii. image difference processor,
- iv. mean scene processor,
- v. chopper controller and data output

2.3.1 Power Supply

The system requirements are for ± 12 V analogue, ± 5 V analogue, and ± 5 V digital power supplies (Circuit 2). The power source, 12 Volt DC from an external PSU or battery, is isolated from the system supplies by using an isolated DC to DC converter thus eliminating the possibility of earth loops through the power supply. The DC to DC converter outputs are filtered to provide the ± 12 V supplies. These are then regulated to provide the ± 5 V supplies. Conventional monolithic regulators are not used in order to keep the quiescent power consumption as low as possible, and to reduce the noise on the analogue supplies to a few tens of microvolts RMS. Separate analogue and digital grounds are provided for the system.

2.3.2 Analogue Processor

The functions performed on this board include the master oscillator and timing generator, analogue amplification, bandwidth limiting, offset reduction, and digitisation (Circuit 3, Figure 6). The system timing is generated using a variable frequency oscillator and a EPLD programmed as a state machine, giving a possible range of line rates from 40 to 100 per second. The analogue offset reduction circuit compares the input to the sample/hold circuit against references set well inside the ADCs dynamic range. If the output from a detector element exceeds this range, a correction value is incremented or decremented, and a new correction value fed to the incoming data via a current DAC. A dual sample/hold circuit is used to enable maximum use to be made of the output by the ADC, and to enable a long settling time to be achieved providing a low-pass filter function. A 14 bit ADC used to 12 bit resolution ensures accurate digitisation of the analogue waveform.

2.3.3 Image Difference Processor

This process has the effect of removing DC and slowly changing offsets from the detector elements, leaving only signal due to the modulating effect of the chopper (Circuit 4). The 12 bit offset binary values corresponding to samples of each detector element in the array are delayed by a half and a full chopper cycle. The three samples from each element are summed together in the form $(-V_1 + 2V_2 - V_3)$, the output being given as a 12 bit offset binary value (Figure 7).

2.3.4 Mean Scene Processor

This stage of processing removes signal components due to temperature differences between the chopper and the scene average (Circuit 5). Each data word is added to a value corresponding to this difference, which can be updated according the mean value of the preceding line. If the accumulated output from each line is close to the expected value, the mean is not changed, if the error is small the value is incremented or decremented by one every 8 lines, and if the error is large, the value is updated every 2 lines (Figure 8).

2.3.5 Chopper Control and Data Output

The chopper phase is controlled with respect to a reference signal by means of a closed-loop control system, the phase error being sensed once per line (Circuit 6). The reference can be shifted over a 180° range to optimise performance, and this permits a large tolerance in the positioning of the chopper sensing pick-off.

Data is output as a serial data stream with added synchronisation bits. Provision is made for the transmission of one field or both fields of the chopper, though normally only one would be used:- closed + (2x open) - closed. Data output is provided as a differential output for driving a twisted pair cable, or as a LED drive for a fibre-optic link.

3 IMAGE DISPLAY

A number of image display or processing options are possible. The essential component is a data link receiver to interface between the serial data link from the sensor head and parallel port at standard 5 V logic levels. The output from this interface may be fed to a computer for image processing, or to a TV scan converter, to give a "scrolling map" type display.

3.1 DATA RECEIVER

Data is received in the form of a differential signal with undefined DC and common mode level, or from an optical signal via a photodiode (Circuit 7). The signal source is jumper selected, thresholded and converted to 5 V logic levels. The timing generator synchronises to the start bit of the data, which is converted to 12-bit parallel format and latched. An EPROM is used to decode the data to 8-bit format for display purposes.

4 SYSTEM PERFORMANCE

4.1 PERFORMANCE PREDICTION

A thorough analysis of the signal and noise properties of pyroelectric detectors used with image difference processors are given elsewhere^(3,4), but briefly recapping, the signal voltage from the IDP referred to the input is

$$V_{SIG} = pa[T_1 - T_2] / [C + C_A] \quad (1)$$

where p is the pyroelectric coefficient, a the detector area, $T_1 - T_2$ the temperature difference between open and closed fields. C is the detector capacitance and C_A the detector source follower and stray capacitance.

This relates to the incoming radiation flux at the detector, and to the scene temperature via the expressions:

$$[T_1 - T_2] = [(I_{SCENE} - I_{CHOPPER}) / g] \tanh(T_f / 2T_t) \quad (2)$$

where I is the radiation incident on the detector due to the scene and chopper respectively, g is the thermal conductance, T_f is the chopper field time and T_t the thermal time constant of the detector. Assuming the 8-14 micron waveband:

$$I_{SCENE} - I_{CHOPPER} = [1/F^2] \int_8^{14} [dw/dT]_{300} [T_{SCENE} - T_{CHOPPER}] d\lambda \quad (3)$$

$$\approx 0.5 [T_{SCENE} - T_{CHOPPER}] / F^2 \text{ W m}^{-2} \quad (4)$$

where $F = f/\text{no of optics}$ and W is the spectral radiant emittance.

The RMS noise from the detector is derived via the filter function:

$$V^2 = 4 \int_0^{\infty} \frac{e_t^2 \sin^4(\omega T_f/2)}{[1 + (\omega T_f/10N)^2]} df \quad (5)$$

where e_t is the noise spectral density due to the quadrature sum of all the individual noise sources, and N is the number of elements in the detector array.

4.2 MEASURED PERFORMANCE

The responsivity and noise from a typical detector are given as Figures 9 and 10. As an example, processing these figures at 25 and 50 Hz through the IDP process gives predicted NETDs as follows, assuming ideal $f/1$ optics:

NETD ($f/1$) 25 Hz 0.09°C

NETD ($f/1$) 50 Hz 0.19°C

The measured NETD of the prototype imager is 0.25°C at 50 Hz using the lens described previously (25 mm focal length, $f/0.8$), giving a discrepancy between theory and practice of almost 50%. This can be accounted for by a number of factors. Factors which effect the signal include the non-ideal nature of the lens, ie its optical transmission and spectral window, and non-ideal chopping, ie because the chopper does not lie in the focal plane the chopping process is not abrupt, and this results in a loss of signal (Appendix I). Factors which effect the noise include excess noise in subsequent amplification stages, power supply noise, interference (radiated and coupled to power supplies) from the DC-DC converter, quantisation noise and nonlinearity in the ADC and DAC components, and phase noise on the instantaneous chopper position with respect to the detector readout.

It has not so far been possible to apportion the performance degradation from the ideal between these separate sources of reduction of signal-to-noise ratio, though the optics transmission probably forms a significant portion of the loss.

5 DISCUSSION

This sensor system has been shown to have good temperature sensitivity, despite the fact that it does not require many of the features associated with conventional thermal imagers which lead to their high cost and limited applicability, ie high-pressure gas cooling, complex optics, and precision electronics stable against environmental changes. This combination of detector technology and signal processing techniques yields a system which is very robust against the environment in terms of temperature and vibration effects, while the total power consumption of the prototype system is approximately 1.5 Watt, of which at least 50% is wasted in the DC-DC converter currently being used. Thus thermal sensors based on the ideas presented here may be used in such applications as remotely piloted or autonomous land or air vehicles, which might be regarded as expendable in a military application, or which must be low-cost in a civil application; or in unattended sensors for such applications as security, eg imaging intruder alarms.

The ease with which such a sensor can be interfaced to a low-cost computer for image processing and analysis, and the low data rate compared to conventional TV format imagers, leads to its potential use in industrial process-control applications, or as a low-cost highly portable medical or industrial thermal imager when fitted with a motorised

azimuth motion to provide a 2-dimensional scanned image.

An important feature is the inverse dependence of sensitivity on readout rate, giving, for instance, a NETD of 0.025°C at a line readout rate of 5 Hz. For a 64×64 pixel image, this would imply a frame rate of 12 seconds per frame, but the sensitivity is comparable to the very best cooled thermal imagers, and is achieved without the need for an integrating image store.

6 CONCLUSION

An infrared imaging system using a pyroelectric detector and image difference processing has been designed, built and assessed. It has a sensitivity of 0.25°C NETD at 50 Hz, requires no cooling and low electrical power input and should be potentially low-cost in manufacture. The ability to simply trade off chopping rate against sensitivity leads to an extremely flexible system, with sensitivity extending to a few tens of milli-degrees. The techniques described here should make possible the use of thermal imaging of a far wider range of applications than has hitherto been possible.

ACKNOWLEDGEMENTS

The author wishes to acknowledge the support of DCVD (now EC Group, RSRE), MOD(PE) for funding part of the work described here.

The author wishes to acknowledge the co-operation of Philips Components Ltd during the course of this work.

Copyright © Controller HMSO, London

REFERENCES

- 1 "VX 8647 stage A final report", Philips Components Ltd, Report No 10199/R, December 1987.
- 2 "High isolation 64-element pyroelectric linear array IR detector", Turnbull, A A, Proc SPIE Vol 807, 1987.
- 3 "The design of low-noise arrays of MOSFETs for pyroelectric array readout (LAMPAR)", Watton R, Manning P A, Proc SPIE Vol 807, 1987.
- 4 "A new thermal imager using a linear pyroelectric detector array", Manning P A et al, Proc SPIE Vol 918, 1988.

APPENDIX 1. FOCAL PLANE CHOPPING

Simple modelling of chopped pyroelectric detectors usually assumes abrupt or "square wave" modulation of the radiation flux on the detector. This is rarely achieved in real systems, unless an intermediate focal plane is used, since the chopper must be a finite distance away from the detector and therefore intersects the cone of radiation from the lens at a point where it has finite radius.

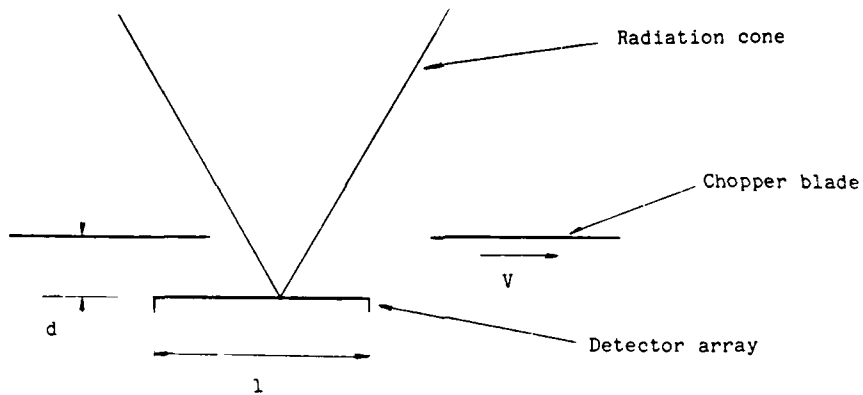

l = length of array, f = f /no of lens, d = distance from chopper to focal plane.
 T = field time, V = velocity of chopper edge along array.

Hence the length of time the chopper takes to traverse half the radiation cone is given by

$$t' = \frac{dT}{2f\theta}$$

The instantaneous radiation flux (I) as a function of time is now defined by

$$-t' < t < t' \quad I = \frac{F}{\pi} \left[\sin^{-1} \frac{t}{t'} + \frac{t}{t'} \left[1 - \frac{t^2}{t'^2} \right] \right]$$

$$t' < t < T-t' \quad I = \frac{F}{2}$$

$$T-t' < t < T+t' \quad I = \frac{F}{\pi} \left[\sin^{-1} \left[\frac{T-t}{t'} \right] + \frac{(T-t)}{t'} \left[1 - \frac{(T-t)^2}{t'^2} \right] \right]$$

and so on.

THIS PAGE IS LEFT BLANK INTENTIONALLY

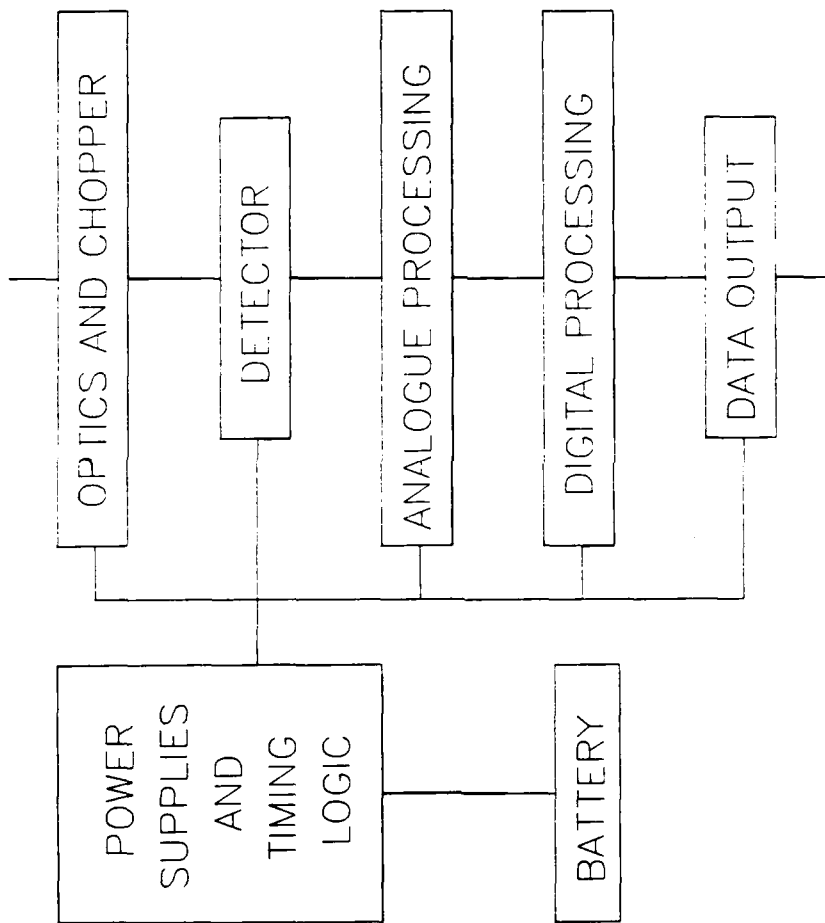

Fig 1 Sensor block diagram

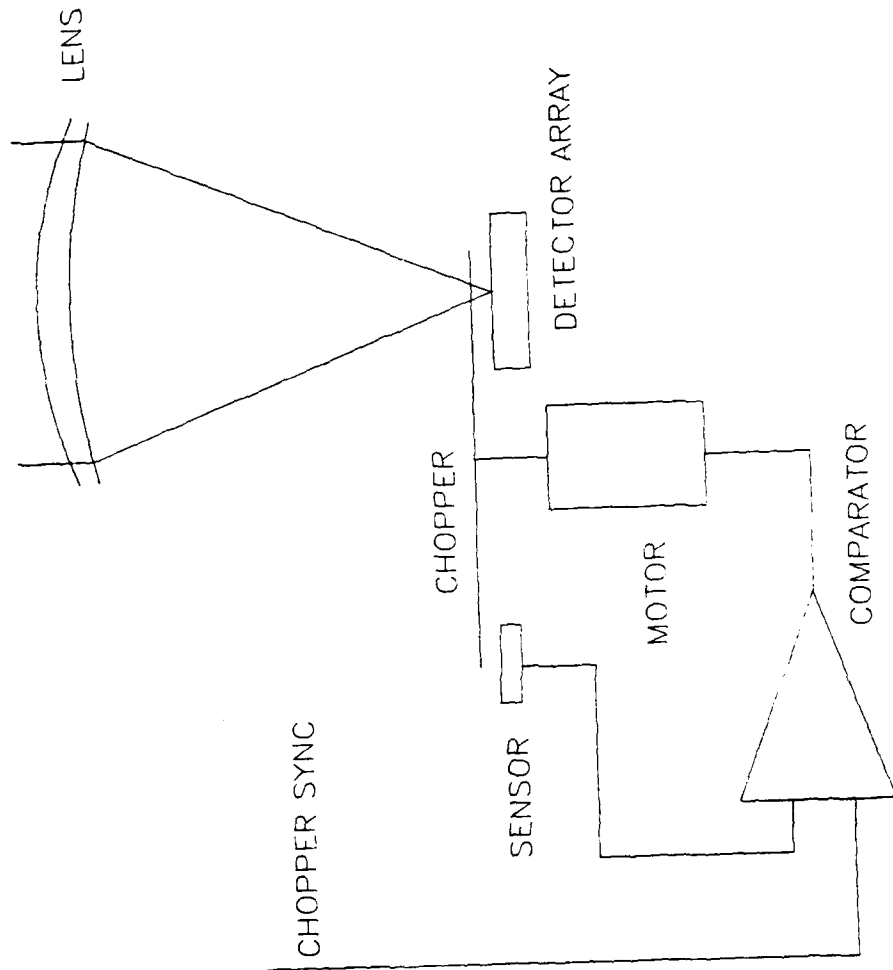

Fig 2 Optics module schematic

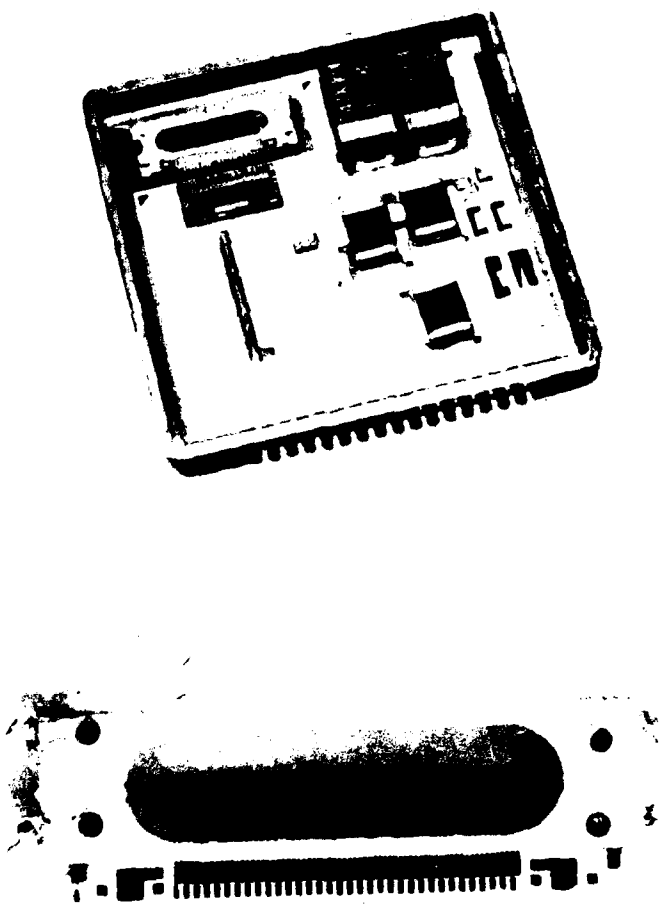

Fig 3 Detector array : physical

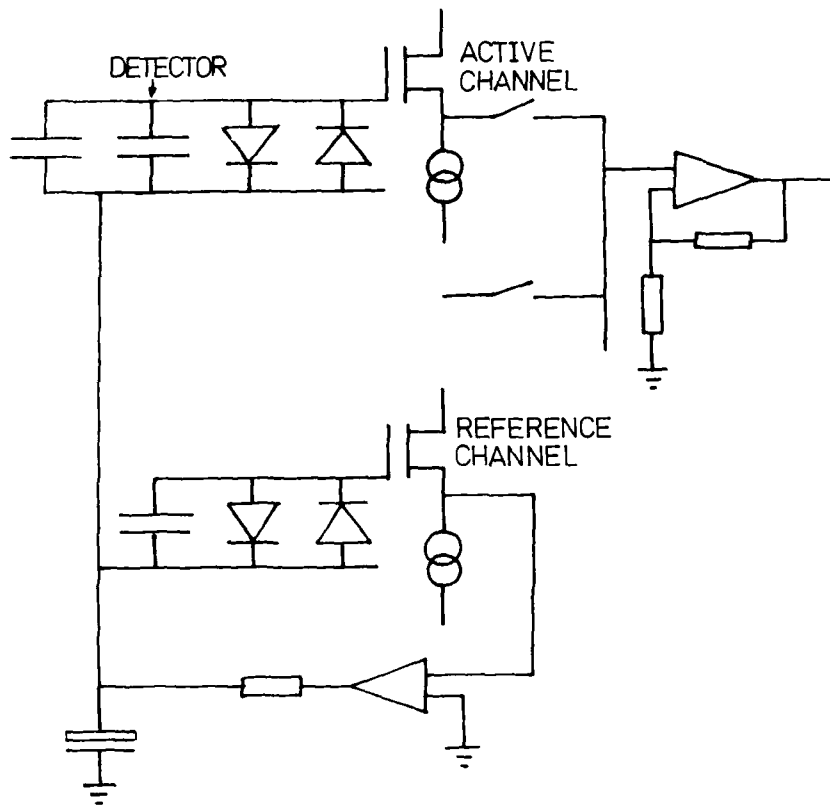

Fig 4 Detector array : schematic

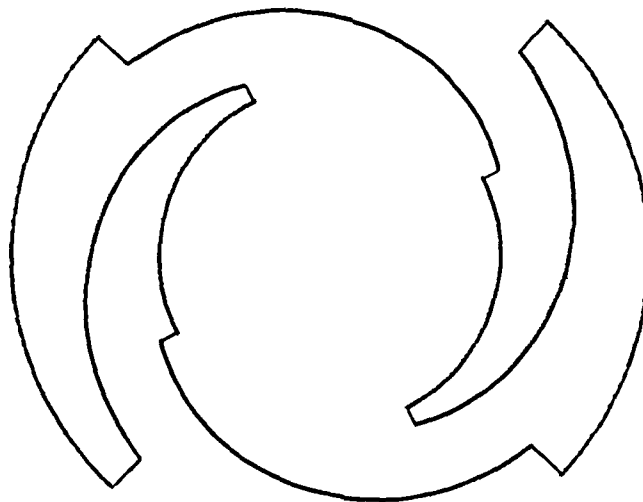

Fig 5 Focal plane chopper

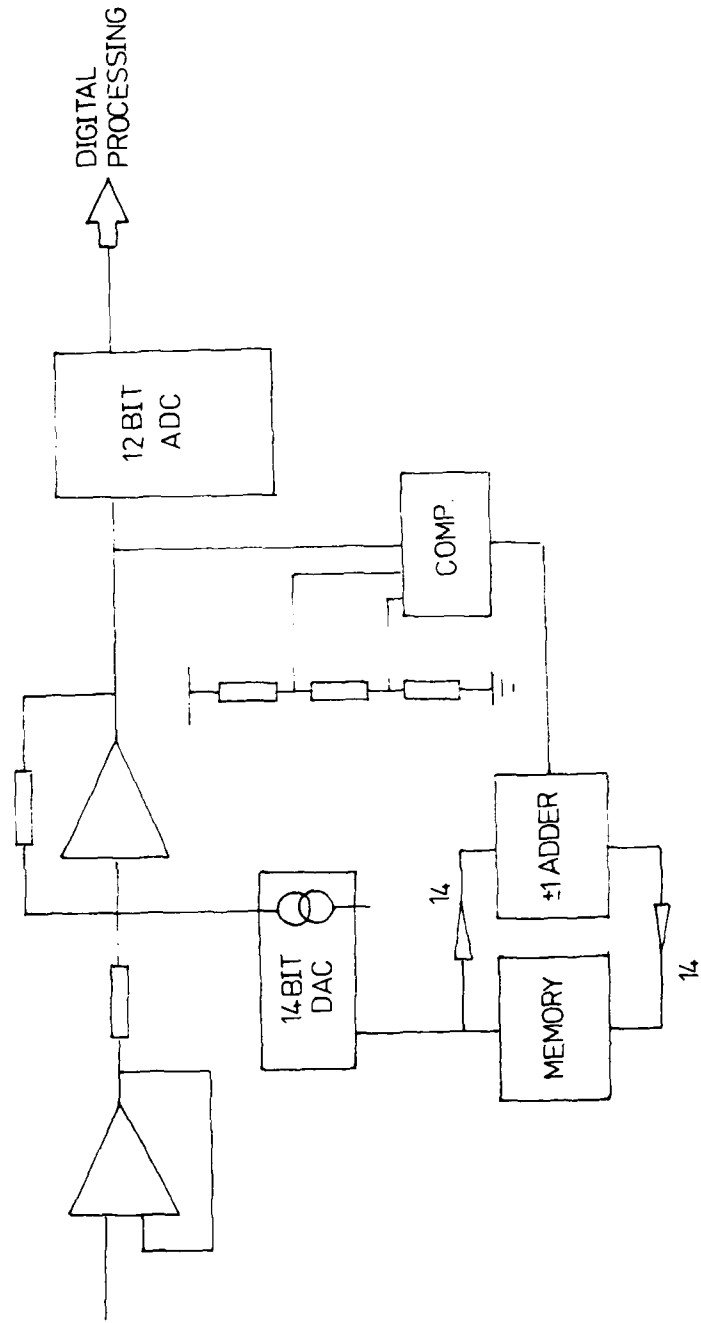
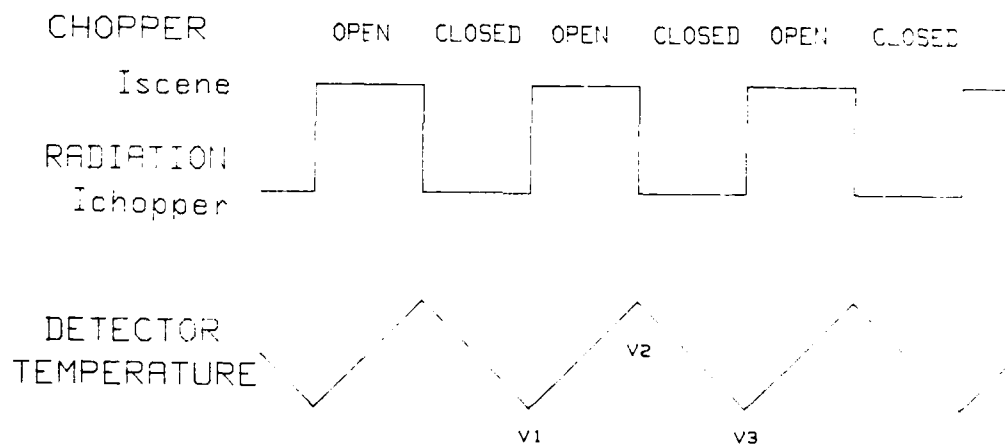
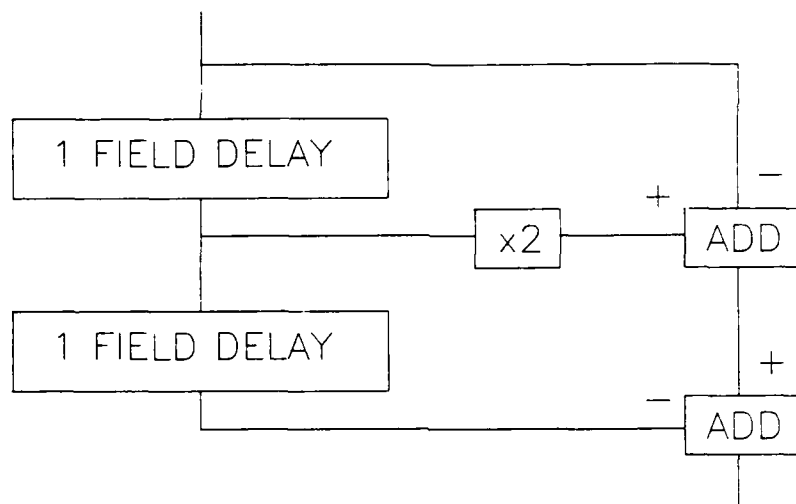

Fig 6 Analogue processing schematic



$$V_{IDP} = (- V1 + 2.V2 - V3)$$

Fig 7 IDP schematic

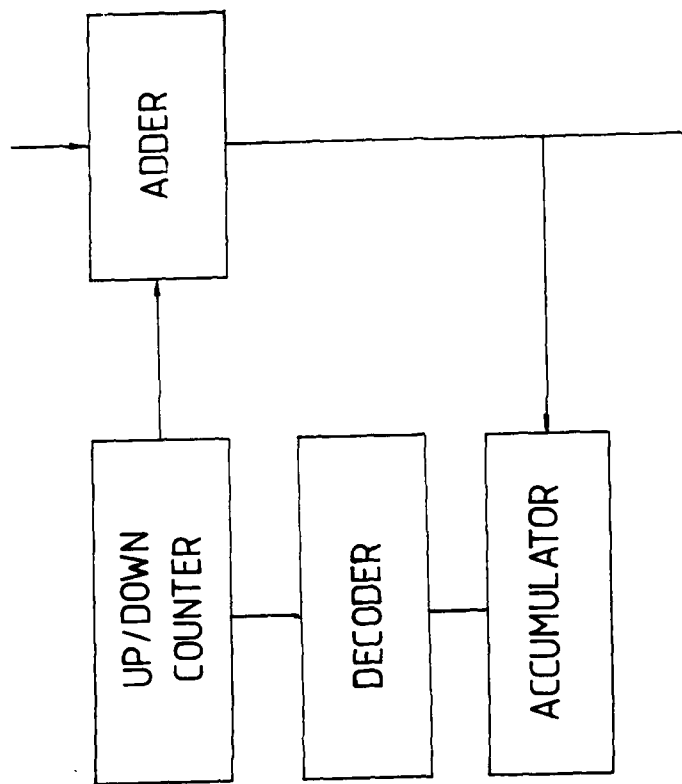
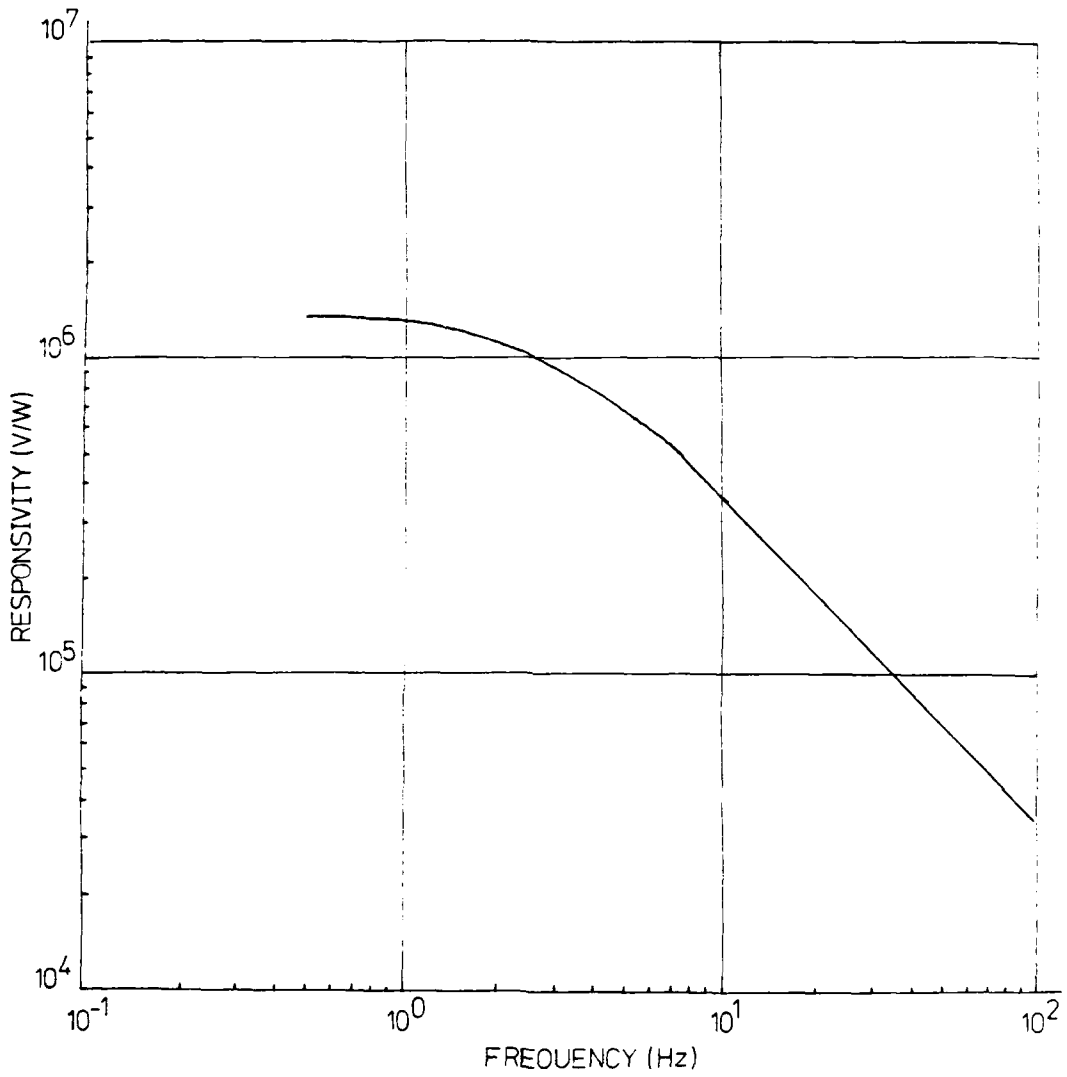

Fig 8 Mean scene processor schematic



*Fig 9 Typical detector
responsivity*

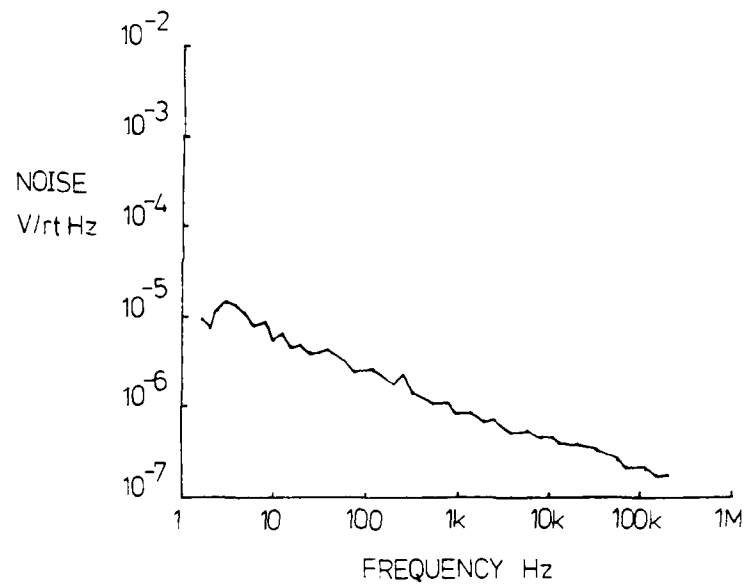
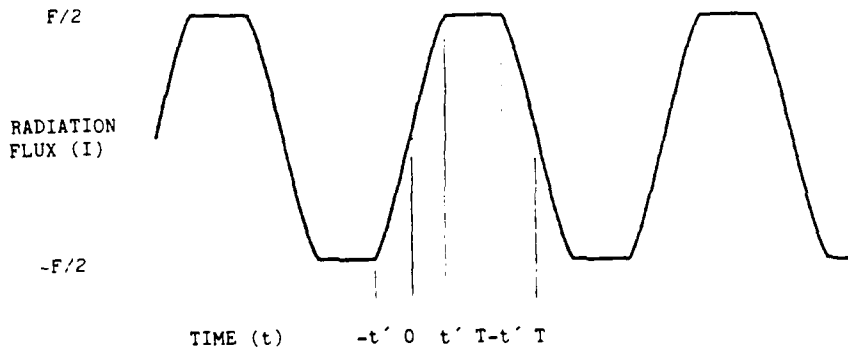

Fig 10 Typical detector noise

THIS PAGE IS LEFT BLANK INTENTIONALLY



Assuming an integrating detector, a good approximation for a pyroelectric detector used above its thermal knee frequency, the chopping efficiency E_c is obtained by integrating the radiation flux between $t = 0$ and $t = T$, and comparing this to result for a square wave chopper (simply $FT/2$). The integral is given by $F/2 (T - (4t'/3\pi))$. Thus the chopper efficiency may be described using the system geometry thus

$$E_c = 1 - \frac{4d}{3\pi f\tau}$$

Hence for the system described here, if $d \approx 2$ mm, we obtain a chopping efficiency of approximately 80%.

THIS PAGE IS LEFT BLANK INTENTIONALLY

APPENDIX 2. CIRCUIT DIAGRAMS

The system described here was designed with the aid of the Futurenet schematic capture CAD package, and manufactured using the RSRE PCB manufacturing facility. Copies of these circuits are therefore available on floppy discs in Futurenet format.

LIST OF CIRCUITS

- 1 Low-noise power conditioning
- 2 Power supply
3. Analogue processor
- 4 Image difference processor
- 5 Mean scene processor
- 6 Chopper control and data output

THIS PAGE IS LEFT BLANK INTENTIONALLY

DOCUMENT CONTROL SHEET

Overall security classification of sheet UNCLASSIFIED

(As far as possible this sheet should contain only unclassified information. If it is necessary to enter classified information, the box concerned must be marked to indicate the classification eg (R) (C) or (S))

1. DRIC Reference (if known)	2. Originator's Reference Memo 4102	3. Agency Reference	4. Report Security Classification UNCLASSIFIED	
5. Originator's Code (if known) 7784000	6. Originator (Corporate Author) Name and Location ROYAL SIGNALS & RADAR ESTABLISHMENT ST ANDREWS ROAD, GREAT MALVERN, WORCESTERSHIRE WR14 3PS			
5a. Sponsoring Agency's Code (if known)	6a. Sponsoring Agency (Contract Authority) Name and Location			
7. Title Readout and signal conditioning for a linear pyroelectric array				
7a. Title in Foreign Language (in the case of translations)				
7c. Presented at (for conference papers) Title, place and date of conference				
8. Author 1 Surname, initials MANNING P A	9(a) Author 2	9(b) Authors 3,4...	10. Date 1988 8	pp. ref. 19
11. Contract Number	12. Period	13. Project	14. Other Reference	
15. Distribution statement UNLIMITED				
Descriptors (or keywords) continue on separate piece of paper				
Abstract A pyroelectric infrared detector and associated components are described which together make up an uncooled infrared sensor system. The prototype system is low cost, has low power consumption, and has a sensitivity of better than 0.25K.				

THIS PAGE IS LEFT BLANK INTENTIONALLY

END

DATE
FILMED

6-89