

DTIC FILE COPY

2

DOT/FAA/DS-89/07

Advanced System Design Service
Washington, D.C. 20591

**National Airspace System
Search and Rescue
Operational Concept
(NAS-SR-1329)**

AD-A207 327

Advanced System Design Service
Federal Aviation Administration
Washington, D.C. 20591

February 1989

Final Report

This document is available to the public
through the National Technical Information
Service, Springfield, Virginia 22161



U.S. Department of Transportation
Federal Aviation Administration

DTIC
ELECTE
APR 27 1989
S H D

089 4 27 052

NOTICE

This document is disseminated under the sponsorship of the U.S. Department of Transportation in the interest of information exchange. The United States Government assumes no liability for the contents or use thereof.

The United States Government does not endorse products or manufacturers. Trade or manufacturers' names appear herein solely because they are considered essential to the objective of this report.

DISTRIBUTION: A-W(VR/VS/RP/ND/DM/AF/AT)-2; A-W(AP/NS/SE/DS/MC/OR/PS/SM/TO/TR/OP)-3; ACN-140 (8cys); TSC-DTS-53(2cys); ACM-413(25cys); TSC-DTS-930(Library)(4cys)

1. Report No. DOT/FAA/DS-89/07		2. Government Accession No.		3. Recipient's Catalog No.	
4. Title and Subtitle Search and Rescue (SAR) Concept of Operations				5. Report Date January 1989	
				6. Performing Organization Code	
7. Author(s) William Trent, Rodney Kuhn, Thomas Pickerell				8. Performing Organization Report No.	
9. Performing Organization Name and Address Computer Resource Management, Inc. 2110-C Gallows Road Vienna, VA 22180				10. Work Unit No. (TRAIS)	
				11. Contract or Grant No. DTF A01-88-Y-01073	
12. Sponsoring Agency Name and Address U.S. Department of Transportation Federal Aviation Administration 800 Independence Ave., S.W. Washington, DC 20591				13. Type of Report and Period Covered	
				14. Sponsoring Agency Code ADS-110	
15. Supplementary Notes 1-1					
16. Abstract A requirement for the National Airspace System (NAS) is to provide for detecting the need for initiating and assisting in search and rescue activities, as identified in the NAS System Requirement Specification, NAS-SR-1000. This document presents a concept of operations for search and rescue. It describes search and rescue assistance capabilities and shows the relationships between subsystems, facilities, information, and operators/users. It is intended to provide a common perspective for personnel involved in search rescue activities, assist in determining whether the search and rescue procedures meet formal requirements, and support coordination among the organizations involved with search and rescue assistance.					
17. Key Words Search and Rescue National Airspace System Air Traffic Control, () Operational Concept			18. Distribution Statement Document is available to the public through the National Technical Information Service Springfield, VA 22161		
19. Security Classif. (of this report) Unclassified		20. Security Classif. (of this page) Unclassified		21. No. of Pages 51	22. Price

TABLE OF CONTENTS

	<u>Page</u>
LIST OF FIGURES	iii
LIST OF TABLES	iii
1.0 INTRODUCTION	1-1
1.1 Background	1-1
1.2 Objective	1-1
1.3 Scope	1-1
1.4 Methodology	1-2
1.5 Document Organization	1-3
2.0 SEARCH AND RESCUE OPERATIONS	2-1
2.1 Support	2-1
2.2 Information	2-5
2.2.1 Information from the Flight Plan	2-5
2.2.2 Information about Weather Conditions	2-6
2.2.3 Information about ELT Signals	2-6
2.2.4 Information from the NAS	2-6
2.3 Functions	2-6
2.3.1 In-Flight Specialist (Position 3)	2-7
2.3.2 Direction Finder Specialist (Position 5)	2-7
2.3.3 NOTAM Specialist (Position 21)	2-9
2.3.4 Approach/Departure Controller (Position 6) and En Route Controller (Position 7)	2-13
2.3.5 Area Manager (Position 23)	2-16
2.3.6 Clearance Delivery Controller (Position 11)	2-18
2.4 Correlation with Operational Requirements	2-19
2.5 Operational Sequences	2-22



Revision For	
SP&I	<input checked="" type="checkbox"/>
IM	<input type="checkbox"/>
Unread	<input type="checkbox"/>
Location	
by	
Distribution/	
Availability Codes	
Dist	Avail and/or Special
A-1	

TABLE OF CONTENTS
-CONT'D-

	<u>Page</u>
2.5.1 En Route VFR Operational Sequence	2-22
2.5.2 En Route IFR Operational Sequence	2-26
2.5.3 Terminal Area Operational Sequence	2-29
2.6 Operational Scenario	2-29
REFERENCES	RE-1
GLOSSARY	GL-1
ACRONYMS/ABBREVIATIONS	AA-1

LIST OF FIGURES

<u>Figure Number</u>		<u>Page</u>
2-1	OVERVIEW OF NAS/USER INTERFACES FOR SEARCH AND RESCUE	2-2
2-2	SEARCH AND RESCUE BLOCK DIAGRAM	2-3
2-3	IN-FLIGHT SPECIALIST SEARCH AND RESCUE OPERATIONAL FLOW DIAGRAM	2-8
2-4	DF SPECIALIST SEARCH AND RESCUE OPERATIONAL FLOW DIAGRAM	2-10
2-5	NOTAM SPECIALIST SEARCH AND RESCUE OPERATIONAL FLOW DIAGRAM	2-12
2-6	APPROACH/DEPARTURE CONTROLLER AND EN ROUTE CONTROLLER SEARCH AND RESCUE OPERATIONAL FLOW DIAGRAM	2-15
2-7	AREA MANAGER SEARCH AND RESCUE OPERATIONAL FLOW DIAGRAM	2-17
2-8	CLEARANCE DELIVERY CONTROLLER SEARCH AND RESCUE OPERATIONAL FLOW DIAGRAM	2-20
2-9	EN ROUTE VFR OPERATIONAL SEQUENCE DIAGRAM	2-23
2-10	EN ROUTE IFR OPERATIONAL SEQUENCE DIAGRAM	2-27
2-11	TERMINAL AREA OPERATIONAL SEQUENCE DIAGRAM	2-30
2-12	VFR SEARCH AND RESCUE SCENARIO	2-31
2-13	IFR SEARCH AND RESCUE SCENARIO	2-33

LIST OF TABLES

<u>Table Number</u>		
2-1	SEARCH AND RESCUE OPERATIONAL REQUIREMENTS CORRELATION	2-21

1.0 INTRODUCTION

1.1 Background

National Airspace System (NAS)

There are many emergency situations which require assistance. They include aircraft becoming lost, overdue, or making a forced landing. Many Federal, State, and Local agencies supply resources for providing Search and Rescue (SAR) assistance. The NAS is required to detect the need, and to initiate and assist in SAR operations. The National Airspace System Requirements Specification (NASSRS), NAS-SR-1000, describes the requirements for providing this assistance to the users.

This operational concept document has been developed using an established standard format and is consistent in structure with a series of operational concepts written about various sections of the NASSRS. I

1.2 Objective

The objective of this operational concept is to describe how Search and Rescue assistance is provided in the National Airspace System (NAS) "end state" system. This document is intended as a descriptive document to provide management and technical personnel of the FAA, as well as outside organizations, with a clear understanding of how the SAR services are provided. More specifically, the purpose of this document is to:

1. Provide a common operational perspective across subsystems, operators, and users.
2. Show the interrelationship between subsystems, facilities, information, and operators/users.

1.3 Scope

This Search and Rescue Operational Concept describes the services provided as outlined in Section 3.2.9 of the NASSRS. This concept describes services provided by certain types of specialists/controllers. The names assigned these specialist/controller positions in this document are based on the primary function performed and may not be commonly used today or may change at a later date as the NAS evolves, but the functions performed by these positions will not change. The operations described are limited to those associated solely with SAR services. The simplifying constraint of communications transparency has been implemented throughout the development of this operational concept; i.e. communications systems serve only as a "pass through" for information and are therefore not included. Section 3.6 of the NASSRS describes the requirements for communications and is described in another operational concept.

The specific paragraphs in the NASSRS Section 3.2.9 and their contents are as follows:

- 3.2.9.A Detection of overdue or unreported aircraft.
- 3.2.9.B Initiating search and rescue procedures for overdue or unreported aircraft.
- 3.2.9.C Assistance in search and rescue operations.
- 3.2.9.D Monitoring for transmissions from Emergency Locator Transmitters (ELT).
- 3.2.9.E Providing a list of facilities to be contacted in the initial inquiry to locate an overdue aircraft.
- 3.2.9.F Prepare messages for review and transmission to other facilities.
- 3.2.9.G Exchanging information with all agencies and facilities concerned with search and rescue activities.

1.4 Methodology

The methodology employed to develop this operational concept is similar to the methods and tools used for system development in that successive levels of decomposition of the SAR function are represented. This document starts with the overall concept and proceeds to its most elemental levels of support, diagrammatic tools, and techniques that constitute SAR support. These analytical tools are:

1. Operational Block Diagram/Description. The operational block diagram illustrates the connectivity between major elements of the NAS, i.e., processors, specialists/controllers, and the user for those elements that support the service. The operational block diagram in this Operational Concept is extracted from the overall NAS Operational Block Diagram. Principal features of the operational block diagram/description include the following:
 - a. Each specialist/controller is indicated by a number. This number remains the same in every operational concept.
 - b. Dotted lines segregate facilities.
 - c. Solid lines show digital data flow. Voice data flow is not shown.
 - d. The blocks within each facility are the major processors.
2. Operational Flow Diagrams/Descriptions. An operational flow diagram and associated description for each specialist provides detail about the inputs, processes, outputs, and interfaces for each operator; thus, the operational flow diagram provides an expansion of each element of the NAS shown in the SAR component

master block diagram. Operational flow diagrams are used to functionally describe the products and services of individual specialists.

3. Operational Sequence Diagrams/Descriptions. The operational sequence diagram and associated description show a typical sequence of steps taken by operators/ users in supporting SAR operations. Principal features of an operation sequence diagram include the following:
 - a. Users, specialists, and computer systems involved with providing SAR functions are listed along the vertical axis. When required for clarity, other FAA facilities may also be listed on the vertical axis.
 - b. The horizontal axis represents time. Sequential events or functions performed are indicated within separate boxes. Events which may occur simultaneously or near-simultaneously are shown vertically.
 - c. Decision points or points where alternate paths may be followed are indicated by a diamond shape.
 - d. Circles are connectors and indicate exit to, or entry from, another diagram. Circles with a lower case alphabetic character reference an operator function described in the figure listed below the circle. Circles connect either to another sheet of the same diagram or to another diagram; the relevant figure number is listed underneath if connection is to a different diagram. Thus, the relationship between operator/user interactions and relevant NAS subsystems can be depicted.

1.5 Document Organization

The remainder of this document is organized in the following manner. Section 2 is the main body of the document and is divided into six subsections. Section 2.1 provides an overview description of the SAR function and introduces (identifies) the personnel compliment and physical entities (facilities and computer systems), which provide the required support. Section 2.2 describes the information used to provide SAR support. Section 2.3 provides descriptions of the functional decomposition of SAR. Section 2.4 provides a correlation with Operational Requirements defined in the NASSRS. Sections 2.1, 2.2, 2.3, and 2.4 reference related NASSRS 3.2.9 subsections. Section 2.5 provides a sequence of interactions between system and personnel entities during the planning and the implementational phases of SAR operations, and Section 2.6 presents SAR operational scenarios.

2.0 OPERATIONS

2.1 Support

The NAS is required to provide Search and Rescue assistance services to users. This requirement is described in Section 3.2.9 of the NASSRS. SAR assistance may be provided by Automated Flight Service Station (AFSS) specialists, En Route and Approach/Departure Controllers at an Area Control Facility (ACF), or the Clearance Delivery controller at an Airport Traffic Control Tower (ATCT).

Figure 2-1 is an overview of NAS/user interfaces for SAR services and illustrates the NAS facilities and systems involved.

Figure 2-2 is an operational block diagram showing the interrelationships between equipment, facilities, operators/users and the information necessary to support SAR operations. The following paragraphs briefly summarize SAR operations at each position shown in Figure 2-2.

Position 3: In-Flight Specialist

Function: Monitors 121.5/243.0 MHz for ELT transmissions and provides DF assistance to en route VFR pilots.

Description: When notified by an outside agency, that an aircraft is overdue, this specialist in the AFSS provides location information to the NOTAM Specialist who, in turn, initiates SAR procedures.

Procedures: FAA, Flight Service Station Procedures
(7110.10I): Chapter 3, Section 3; Chapter 4, Section 1.

Projects: NAS Plan, Flight Service and Weather Systems: Project 1, Flight Service Automation System (FSAS).

Position 5: DF Specialist

Function: Provides location information to pilots requesting assistance.

Description: A specialist in the AFSS who provides location and headings to lost or disoriented pilots using equipment that locates the aircraft's VHF transmitter. The DF specialist may talk directly to the pilot or he may relay the DF instructions through another specialist handling the aircraft. This position is usually combined with the Inflight Specialist position.

Procedures: FAA, Flight Service Station Procedures
(7110.10I): Chapter 5, Section 3.

Projects: Ground-To-Air Systems: Project 11,
Direction Finder (DF).

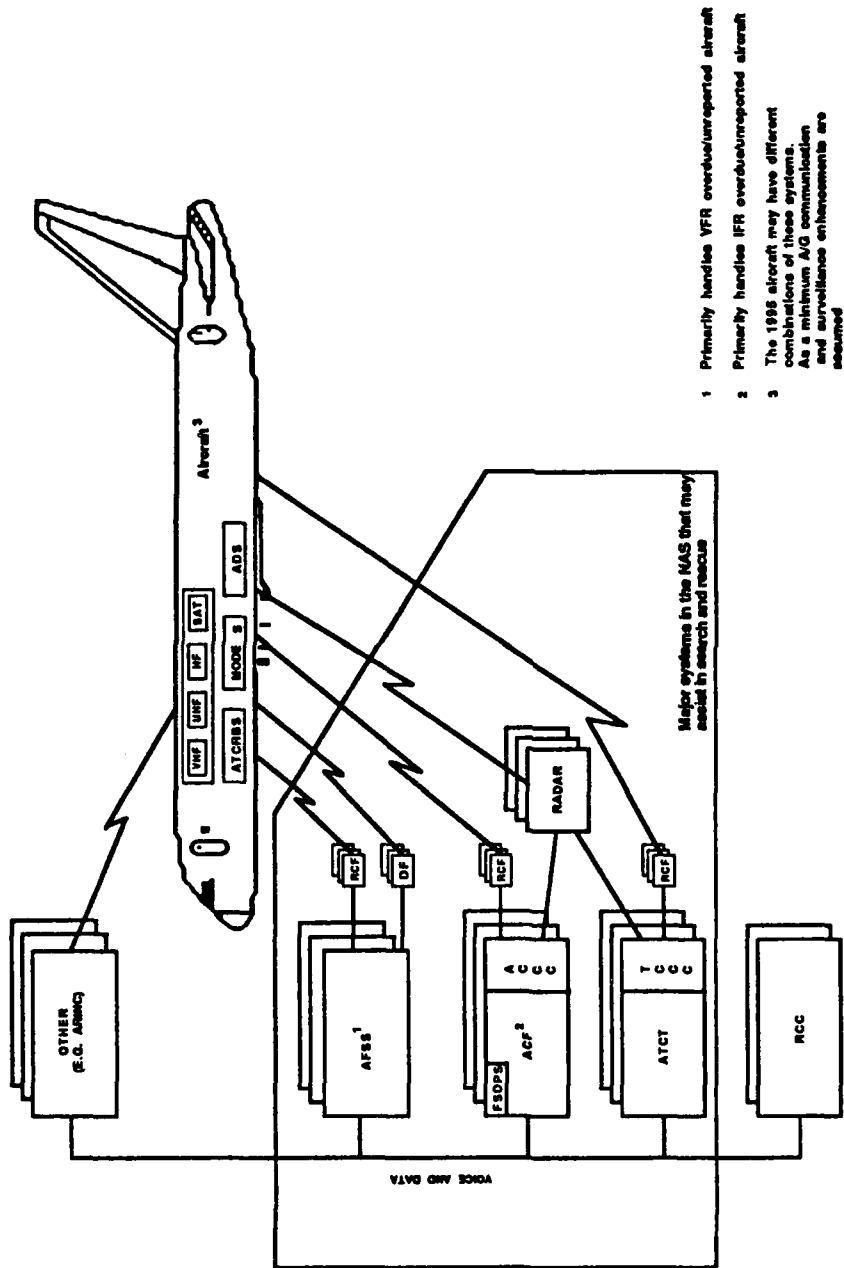

- 1 Primarily handles VFR overdue/unreported aircraft
- 2 Primarily handles IFR overdue/unreported aircraft
- 3 The 1998 aircraft may have different combinations of these systems. As a minimum A/G communication and surveillance enhancements are assumed

**FIGURE 2-1
OVERVIEW OF NAS/USER SYSTEMS
FOR SEARCH AND RESCUE**

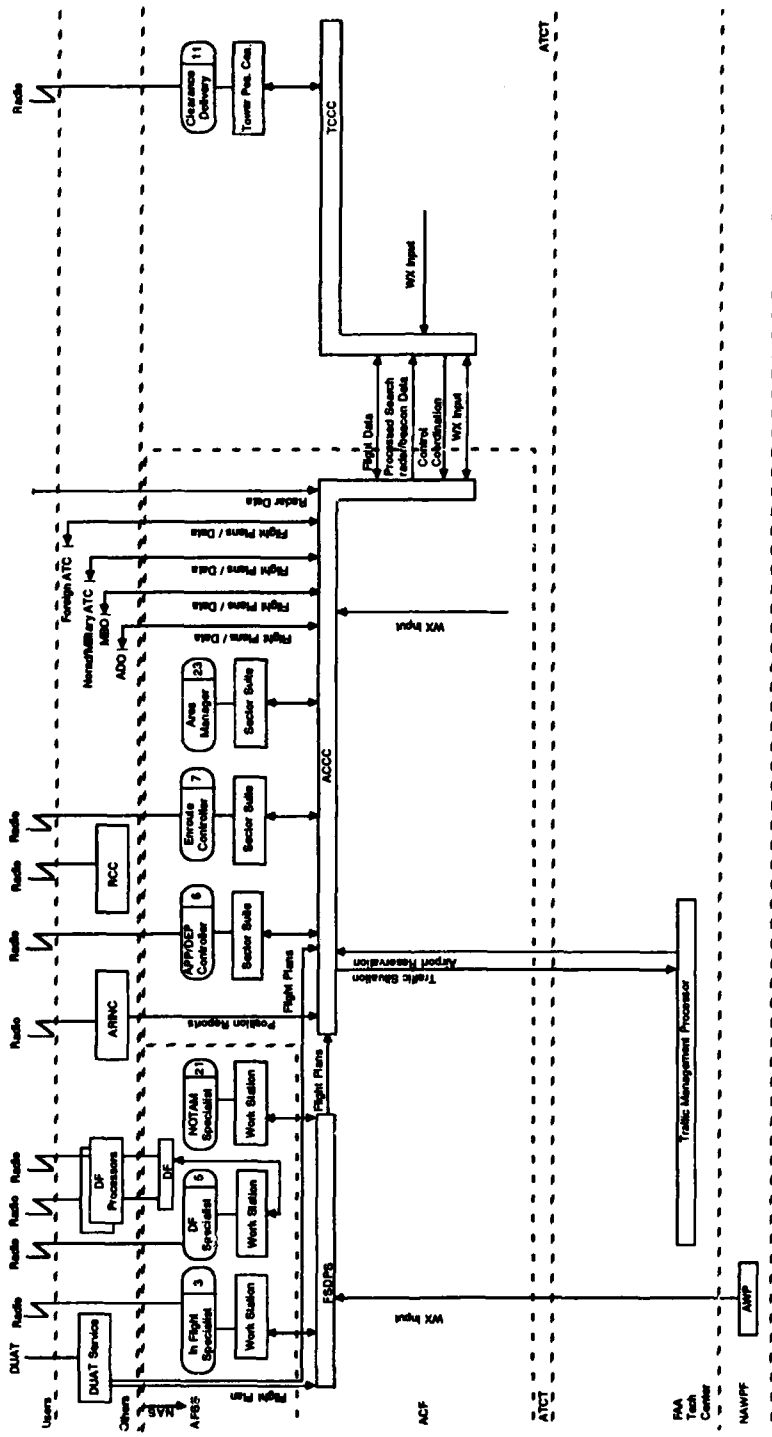

FIGURE 2-2
OPERATIONAL BLOCK DIAGRAM

Position 21: NOTAM Specialist

Function: Monitors and queries flight database for overdue and unreported aircraft. Initiates and coordinates SAR procedures.

Description: Once notified that an aircraft on a VFR Flight Plan is thirty (30) minutes overdue (15 minutes if over hazardous areas), the NOTAM Specialist detects the need for SAR and initiates initial information requests and INREQ messages.

Procedures: FAA, Flight Service Station Procedures
(7110.10I): Chapter 8, Sections 1 through 5.

Projects: NAS Plan, Flight Service and Weather Systems: Project 1, Flight Service Automation System (FSAS).

Position 6: Approach/Departure Controller

Function: Assists in SAR operations for overdue and unreported aircraft.

Description: The Approach/Departure Controller, once notified that an aircraft is overdue, attempts to locate the overdue aircraft, and queries the flight database for its last known position. The Approach/Departure Controller uses the Sector Suite to access the flight database that is stored in the Area Control Computer Complex (ACCC).

Procedures: FAA, "Air Traffic Control (7110.65E)";
Chapter 2, Section 1; Chapter 3, Section 10; Chapter 4, Sections 3 and 7; Chapter 9, Sections 1 through 3.

Projects: NAS Plan, En Route Systems: Project 15, Area Control Facilities (ACF); Terminal Systems: Project 13, ATCT/TRACON establishment replacement, and modernization.

Position 7: En Route Controller

Function: Provides SAR assistance to overdue or unreported aircraft.

Description: Once notified that an aircraft is overdue or unreported, the En Route Controller accesses the flight database to determine the aircraft's last known position. The flight data-base is stored in the ACCC and is accessed through their Sector Suites.

Procedures: FAA, "Air Traffic Control (7110.65E)";
Chapter 2, Section 1; Chapter 4, Sections 3 and 7;
Chapter 9, Sections 1 through 3.

Projects: NAS Plan, En Route Systems: Project 15, Area Control Facilities (ACF).

Position 23: Area Manager

Function: Coordinates SAR operations from the ACF.

Description: The Area Manager receives information on overdue/unreported aircraft from controllers in the ACF and attempts to contact appropriate agencies. The Area Manager prepares and ensures that the Alert Notice (ALNOT) is distributed to appropriate agencies.

Procedures: FAA, Facility Operation and Management Handbook (7210.3H).

Projects: NAS Plan, En Route Systems: Project 15, Area Control Facilities (ACF).

Position 11: Clearance Delivery Controller (Flight Data)

Function: Provides assistance in SAR operations.

Description: The Clearance Delivery (Flight Data) Controller initiates SAR actions when notified that an aircraft is overdue or unreported.

Procedures: FAA, "Air Traffic Control (7110.65E)"; Chapter 2, Section 1; Chapter 3, Section 10; Chapter 4, Sections 3 and 7; Chapter 9, Sections 1 through 3.

Projects: NAS Plan, Terminal Systems: Project 13, ATCT/TRACON establishment, replacement, and modernization.

2.2 Information

Since SAR is an effort that increases in intensity over time and expands in terms of the scope of resources required until a lost aircraft is found, the amount of information required to provide search and rescue will vary. Most SAR operations will require, however, a core of information obtained from a number of sources within the NAS.

2.2.1 Information from the Flight Plan

Flight plan information is obtained from the filed flight plan and amendments. Other information such as last known position of the aircraft and the last recorded heading is determined from actual pilot reports or other data. When SAR is initiated, further information is obtained from the flight plan. This flight plan information is stored in one of several processors, depending on where the flight plan was filed. The information is then made available if a SAR request is received concerning the particular flight plan in question. Additional fields obtained from the complete flight plan information provide a more detailed description, and include color of aircraft, the number of people on board, the amount of fuel on board before departure, the pilot's name and address, etc. This information may be stored at the FSDPS, a DUAT service, or the ACCC.

2.2.2 Information about Weather Conditions

Information concerning weather conditions including the weather conditions in the area of last recorded or last known position of the aircraft, and the weather conditions along the last reported heading or predicted flight path as projected, are required as a minimum for SAR operations. This weather information is obtained from such sources as the FAA and the National Weather Service and is available to the specialist through the FSDPS.

2.2.3 Information about ELT signals

Most aircraft in the United States are equipped with an Emergency Locator Transmitter (ELT). This transmitter is battery operated and emits a distinctive audio tone on 121.5 MHz or 243.0 MHz. If armed they are designed to automatically activate when subjected to crash generated forces and continuously emit these signals. The location of any ELT signal is determined from direction finding (DF) triangulation within the NAS or through outside agencies, pilot reports (PIREP), and Search and Rescue Satellite (SARSAT). SARSAT is a group of satellites that circle the earth monitoring frequencies 121.5/243.0 MHz. When an ELT is detected the satellite relays the position of the transmission to the satellite tracking facility, which in turn relays the information to the RCC.

2.2.4 Information from the NAS

The NAS facilities and resources provides a list of aerodromes, terminal areas, and ACFs located within a 100-mile-wide corridor along the projected route from the last known or last reported position of the aircraft. This allows SAR personnel to determine the initial area of search.

2.3 Functions

The following paragraphs describe in more detail the functions provided by the specialist/controller positions introduced in Section 2.1. The Operational Flow Diagrams associated with each paragraph illustrate the information flow between the specialist and the user, between the specialist and other specialists, and between the specialist and data processing equipment. The functions performed by the NAS are explicitly covered by requirements specified in the NASSRS. The pertinent NASSRS paragraphs that specify the function being performed by the NAS are referenced in each of the paragraphs that follow. As used in this paragraph, the term "specialist" also includes controllers.

2.3.1 In-Flight Specialist (Position 3)

The In-Flight Specialist provides SAR assistance once notified that an aircraft is overdue or unreported. The In-Flight Specialist is responsible for monitoring all in-flight frequencies, including the emergency frequencies of 121.5/243.0 MHz for ELT transmissions.

Figure 2-3 is an operational flow diagram describing the functions and services provided by the In-Flight Specialist at the AFSS. Functions performed by the equipment and the In-Flight Specialist are lettered within each block and are described in the corresponding paragraphs below.

- a. FSDPS Processing. The Flight Service Data Processing System (FSDPS) provides the processing capability and support to enable the AFSS specialist to assist in SAR by providing aerodrome information within a 100 mile-wide corridor along the projected route of flight.

NASSRS Requirement 3.2.9.E.

- b. Assistance in Search and Rescue. The In-Flight Specialist provides essential information concerning overdue/unreported aircraft, including: information contained on original and amended flight plan, last recorded or last known position, last recorded heading, and weather conditions along projected path.

NASSRS Requirement 3.2.9.C.1.

- c. Essential Information. The FSDPS provides essential information from the flight data base to the specialist.

NASSRS requirement 3.2.9.C.2.

- d. Monitors for ELT. The In-Flight Specialist monitors 121.5/243.0 MHz for ELT transmissions.

NASSRS Requirement 3.2.9.D.1 & 2.

2.3.2 Direction Finder Specialist (Position 5)

The DF Specialist assists SAR operations by determining an aircraft's location using direction finding equipment. This specialist also monitors 121.5 and 243.0 MHz for ELT transmissions and can determine the geographical coordinates of the transmitting aircraft.

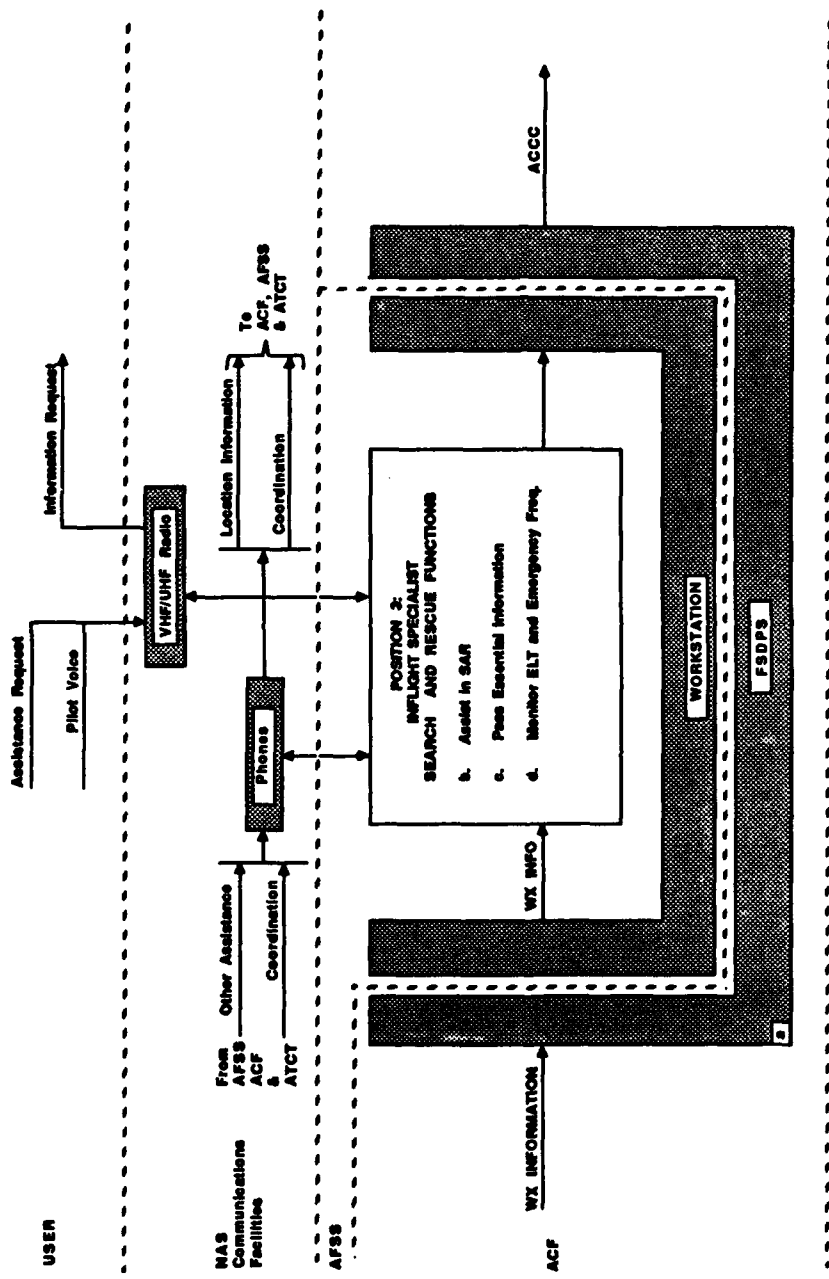

**FIGURE 2-3
OPERATIONAL FLOW DIAGRAM, POSITION 3: IN-FLIGHT SPECIALIST
PROVIDING SEARCH AND RESCUE ASSISTANCE**

Figure 2-4 is an operational flow diagram describing the functions and services provided by the DF Specialist at the AFSS. Functions performed by the equipment and this specialist are lettered within each block and are described in the corresponding paragraphs below.

- a. DF. The DF equipment determines the aircraft's location from the radio signals transmitted from the aircraft.

NASSRS Requirement 3.2.9.C.

- b. Provide assistance in Search and Rescue operations (such as position information). The Direction Finder Specialist determines the aircraft's position using the DF equipment.

NASSRS Requirement 3.2.9.C.

- c. Monitor transmissions from Emergency Locator Transmitters (ELT). The DF Specialist monitors frequency 121.5/243.0 MHz to detect ELT transmissions.

NASSRS Requirement 3.2.9.D.1 and 2.

- d. Provide geographic coordinates of ELT transmission sites. Upon receiving an ELT transmission, or report of an ELT transmission from a non-ATC source, the DF Specialist utilizes his DF equipment, or a combination of pilot reports and satellite reports, to determine the geographic coordinates of ELT transmission sites.

NASSRS Requirement 3.2.9.D.4.

2.3.3 NOTAM Specialist (Position 21)

NOTAM Specialists are notified by the FSDPS whenever a VFR flight plan is 30 minutes overdue (15 minutes when over established hazardous areas). From their position they can query the flight data base to review the full flight plan for further information.

The NOTAM Specialist initiate a communications search within a 100-mile-wide corridor along the aircraft's intended route of flight. If not found, an initial information request called a "QALQ" message is generated. This message is issued to the departure station to request additional information. If the results of this action are negative, the NOTAM Specialist initiates an Information Request (INREQ) to all stations along the same 100-mile-wide corridor (including terminal control facilities and ACF's) and to the RCC. If the aircraft is not found within one hour after the INREQ, or the results are negative, the NOTAM Specialist issues an Alert Notice (ALNOT). Once an ALNOT is issued the NOTAM Specialist calls the RCC to confirm receipt of the ALNOT message.

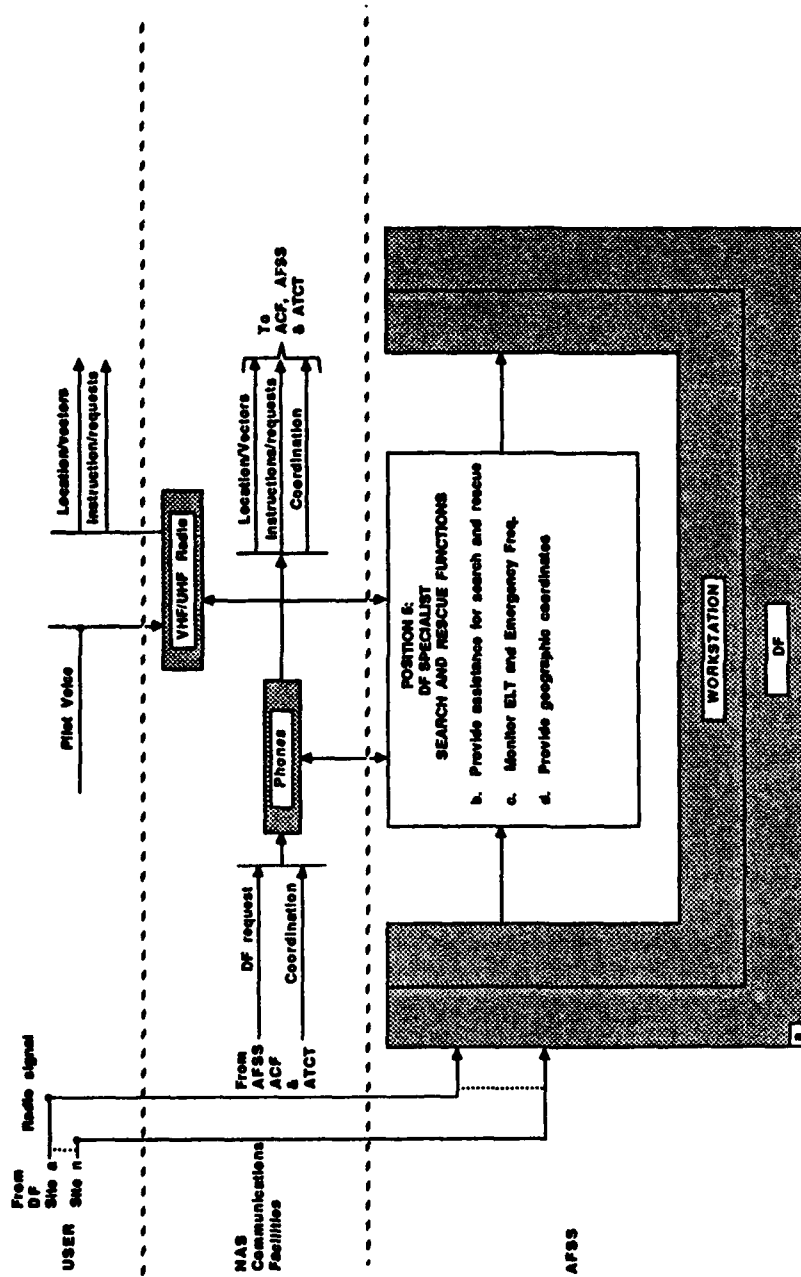

FIGURE 2-4
 OPERATIONAL FLOW DIAGRAM, POSITION 5: DF SPECIALIST
 PROVIDING SEARCH AND RESCUE ASSISTANCE

If after one hour the aircraft is not located or the search results are negative, all pertinent available information about the overdue aircraft not already provided is forwarded to the RCC. The RCC notifies outside agencies such as the Civil Air Patrol, U.S. Coast Guard, state and local law enforcement agencies, etc.

Figure 2-5 is an operational flow diagram describing the functions and services provided by the NOTAM Specialist in the AFSS. Functions performed by the equipment and the NOTAM specialist are lettered within each block and are described in the corresponding paragraphs below.

- a. FSDPS Processing. The FSDPS provides the processing capability and support to enable the AFSS Specialist to detect when an aircraft on a VFR flight plan is 30 minutes overdue (15 minutes for aircraft operating over NAS-designated hazardous areas).

NASSRS Requirement 3.2.9.A.1 through 3.

- b. Detect Overdue or Unreported Aircraft. The NOTAM Specialist is alerted when the difference between the current time and the expected time of arrival (ETA) exceeds 30 minutes (15 minutes over NAS-designated hazardous areas).

NASSRS Requirement 3.2.9.A.1 through 3.

- c. Initiate Search and Rescue. Once notified by the FSDPS that an aircraft is overdue or unreported, the NOTAM Specialist initiates SAR procedures.

NASSRS Requirement 3.2.9.B.

- d. Assist in Search and Rescue Operations. The NOTAM Specialist assists in SAR operations by providing essential information concerning flight plan, last known position, last known heading, weather conditions along last known position, and weather conditions projected along last reported heading or projected flight path.

NASSRS Requirement 3.2.9.C.1.

- e. Essential Information. Essential flight plan information is provided to the NOTAM Specialist through the FSDPS. This information is loaded into the FSDPS by AFSS personnel, the Dial Up Access Terminal (DUATS), or military base operations.

NASSRS Requirement 3.2.9.C.2.

USER

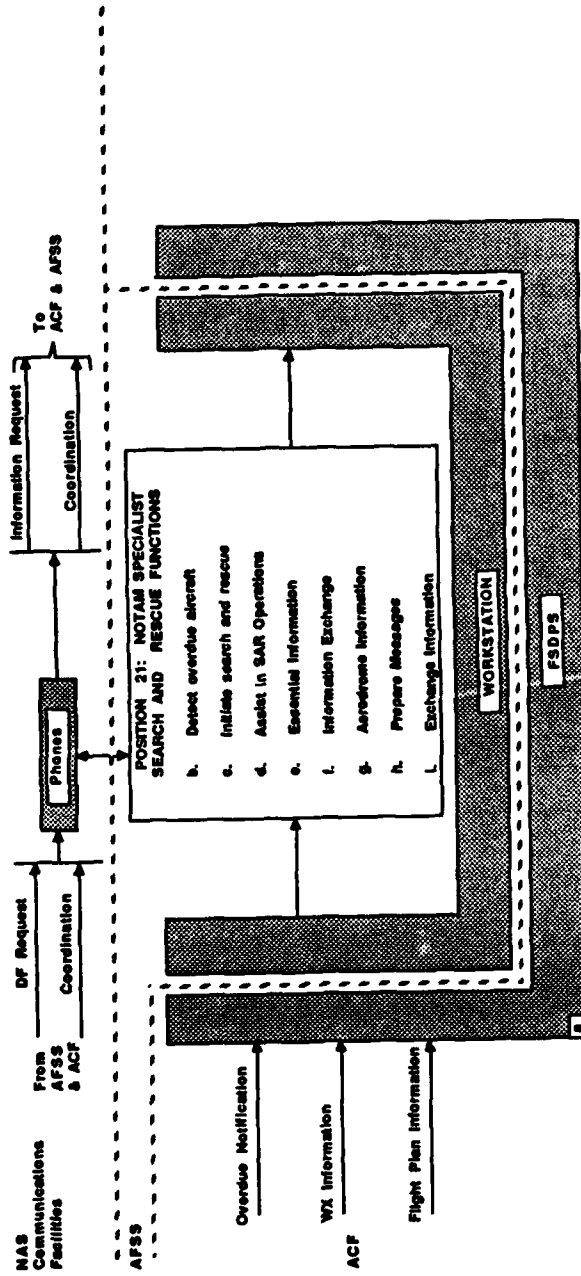

FIGURE 2-5
OPERATIONAL FLOW DIAGRAM, POSITION 21: NOTAM SPECIALIST
PROVIDING SEARCH AND RESCUE ASSISTANCE

- f. Information Exchange. The NOTAM Specialist exchanges essential information with the appropriate rescue coordination center; military, Federal, state, or local SAR facilities; any neighboring foreign ATC and/or military ATC facilities; and airborne pilots in the area.

NASSRS Requirement 3.2.9.C.3.

- g. Aerodrome Information. The NOTAM Specialist position is capable of requesting a list of aerodromes, terminal areas, and ACF's located within a 100-mile-wide corridor along the projected route of the overdue/unreported aircraft.

NASSRS Requirement 3.2.9.E.

- h. Prepare Messages. The NOTAM specialist prepares and review messages prior to transmission. These messages contain, as a minimum, the following information:

1. Type of emergency
2. Aircraft identification
3. Aircraft type and description
4. Destination
5. Aircraft endurance (from flight plan)
6. Last recorded position
7. Last recorded heading
8. Number and identification (if available) of passengers
9. Other remarks deemed pertinent by specialist.

NASSRS Requirement 3.2.9.F.

- i. Exchange Information. The NOTAM Specialist exchanges information with all agencies and facilities concerned with Search and Rescue activities.

NASSRS Requirement 3.2.9.G.

2.3.4 Approach/Departure Controller (Position 6) and En Route Controller (Position 7)

The Approach/Departure Controller and En Route Controller provide assistance to SAR operations when notified that an aircraft is overdue/unreported. The services provided are sufficiently similar to warrant a common description although the focus of the services provided is somewhat different.

Approach/Departure Controllers, when notified of an overdue aircraft in their sector, promptly notifies supervisory personnel who advise the Area Manager. The Area Manager initiates SAR procedures. The AFSS is notified if the aircraft was on a VFR flight plan, or the host ACF if the aircraft was on an IFR flight plan.

When notified by other controllers or through his Sector Suite that an aircraft is overdue/unreported, En Route Controllers initiate SAR procedures for aircraft on an IFR flight plan by notifying their Area Supervisor.

Figure 2-6 is an operational flow diagram describing the functions and services provided by the Approach/Departure Controller and En Route Controller in the ACF. Lettered blocks identify the functions performed by these controllers, which are described in the corresponding paragraphs below.

- a. ACCC Processing. The ACCC, which is used by both Approach/Departure Controllers and En Route Controllers, houses the flight data base that is used to review an IFR aircraft's flight plan. The ACCC is accessed through Sector Suites.

NASSRS Requirement 3.2.9.B, 3.2.9.C.2.

- b. Detect Overdue Or Unreported Aircraft. The Approach and En Route Controllers are notified when the difference between the current time and the expected time of arrival (ETA) at the destination terminal exceeds 30 minutes.

NASSRS Requirement 3.2.9.A.1.

- c. Initiate Search and Rescue. When notified that an aircraft is overdue, these controllers initiate SAR procedures.

NASSRS Requirement 3.2.9.B.

- d. Provide Assistance. Both the Approach/Departure and En Route Controllers query their databases to determine information on an aircraft's filed flight plan, last known position, and weather conditions at the nearest weather reporting station.

NASSRS Requirement 3.2.9.C.1.

- e. Essential Information. The ACCC provides the Approach and En Route Controllers with essential information through their Sector Suites.

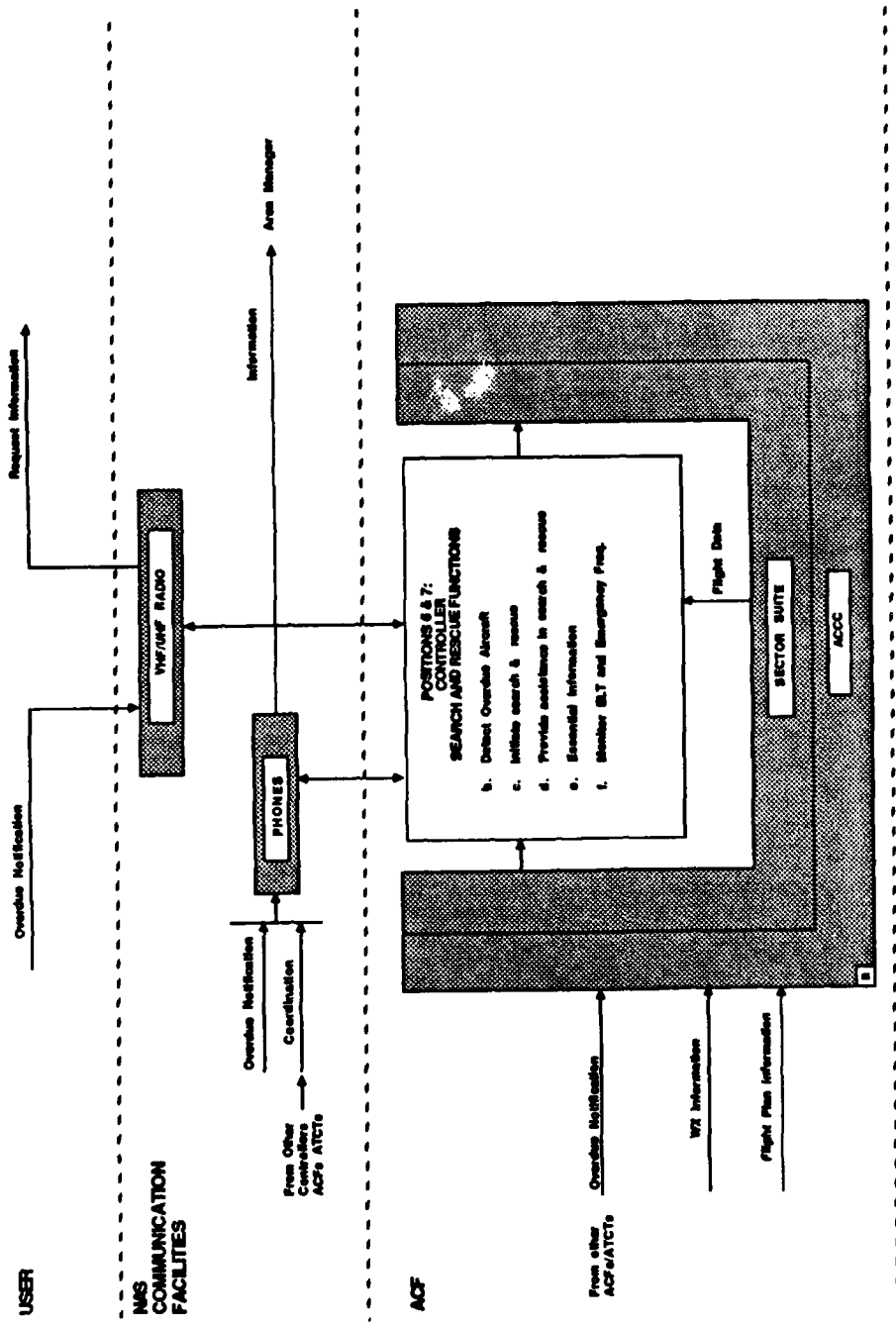

FIGURE 2-6
 OPERATIONAL FLOW DIAGRAM, POSITIONS 6 AND 7:
 APPROACH/DEPARTURE AND EN ROUTE CONTROLLERS
 PROVIDING SEARCH AND RESCUE ASSISTANCE

NASSRS Requirement 3.2.9.C.2.

- f. Monitoring ELT Transmissions. All air traffic control facilities monitor 121.5/243.0 MHz for ELT transmissions on a continuing basis. Additionally, these facilities initiate SAR procedures when notified of an ELT transmission from non-ATC sources, such as pilots, amateur radio operators, and satellites.

NASSRS Requirement 3.2.9.D.1 and 2.

2.3.5 Area Manager (Position 23)

Once notified of an overdue or unreported aircraft, the Area Manager notifies the appropriate facilities with all pertinent information about the aircraft. Upon receiving an INREQ or ALNOT, the Area Manager checks facility records to determine if the aircraft had been contacted by his facility. He notifies the originator of the results of this check within one hour of the time the alert was received.

If his facility had been working the aircraft, the Area Manager initiates an Alert Notice (ALNOT) and pass all pertinent information to the RCC as soon as it is available. Once sent, the Area Manager calls the RCC to confirm receipt of the ALNOT message.

The Area Manager transfers responsibility for further search to the RCC when one of the following occurs:

- a. Thirty minutes have elapsed after the estimated aircraft fuel exhaustion time.
- b. The aircraft has not been located within one hour after ALNOT issuance.
- c. The ALNOT search has been completed with negative results.

The Area Manager cancels the ALNOT when the aircraft is located or the search is abandoned.

Figure 2-7 is an operational flow diagram describing the functions and services provided by the Area Manager. Lettered blocks identify the functions performed, which are described in the corresponding paragraphs below.

USER

WAS
COMMUNICATION
FACILITIES

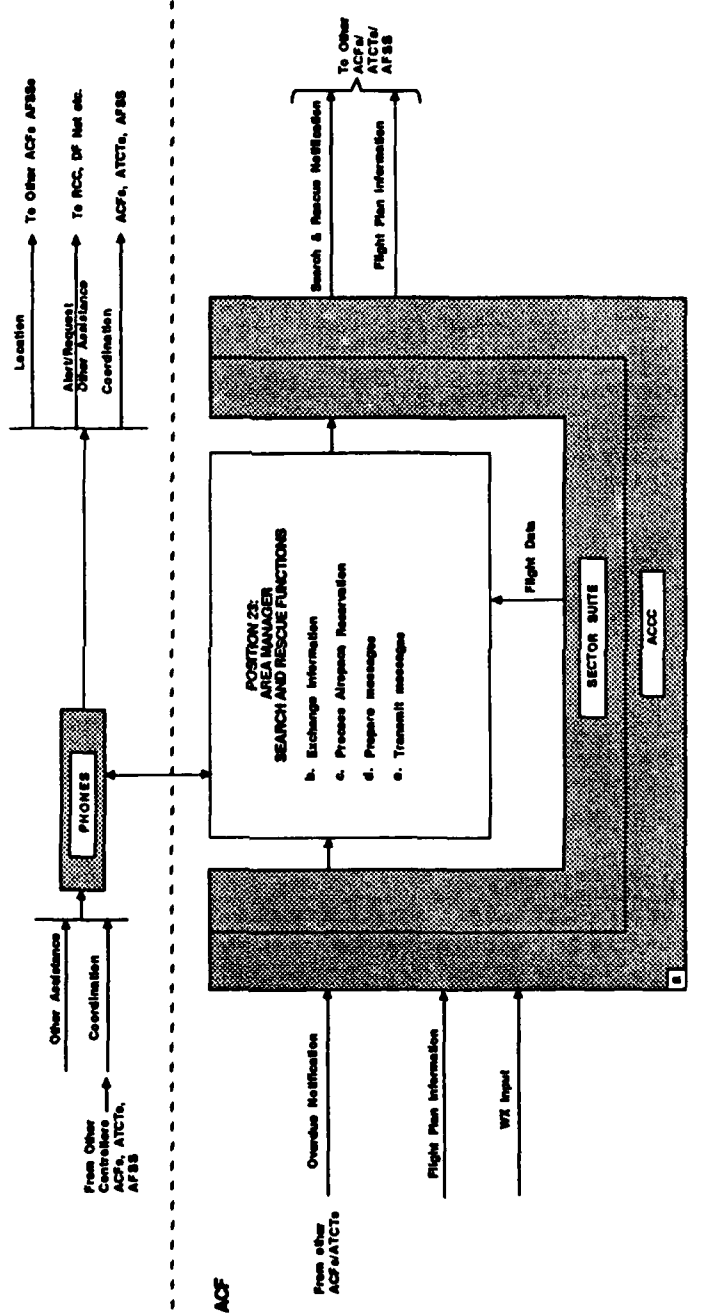

FIGURE 2-7
OPERATIONAL FLOW DIAGRAM, POSITION 23:
AREA MANAGER PROVIDING SEARCH AND RESCUE ASSISTANCE

- a. ACCC Processing. The ACCC, which is used by the Area Manager, houses the flight data base that is used to review an IFR aircraft's flight plan.

NASSRS Requirement 3.2.9.C.2.

- b. Exchange of Essential Information. The Area Manager working in the ACF has access to the same information as the En Route and Approach Controllers as well as: the appropriate Rescue Coordination Center; military, Federal, state, and local Search and Rescue facilities; adjacent foreign ACF and/or military ACF facilities; and pilots airborne in the immediate area to further the exchange of essential information.

NASSRS Requirement 3.2.9.C.3.

- c. Airspace Reservation. The Area Manager, working through his Sector Suite, accesses the ACCC to create an airspace reservation in the immediate area of Search and Rescue operations.

NASSRS Requirement 3.2.9.C.4.

- d. Prepare Messages on Overdue/Unreported Aircraft. The En Route Controllers in the ACF are primarily responsible for initiating SAR on IFR aircraft. When notified that an aircraft is 30 minutes overdue or unreported, the Area Manager prepares and reviews an Alert Notice (ALNOT) message to be transmitted along the aircraft's projected route of flight.

NASSRS Requirement 3.2.9.F.1 and 2.

- e. Transmit Messages Concerning an Overdue/Unreported Aircraft. Once an ALNOT has been reviewed by the Area Manager, it is transmitted via the NADIN network to all agencies and facilities concerned with SAR activities.

NASSRS Requirement 3.2.9.G.1 and 2.

2.3.6 Clearance Delivery (Position 11)

The Clearance Delivery Controller, when notified that an aircraft is overdue or unreported, assists in SAR operations. This controller checks with aircraft on his frequencies, queries the flight database, and advises the supervisory personnel, who forwards any information to the Area Manager in his host ACF.

Figure 2-8 is an operational flow diagram describing the functions and services provided by the Clearance Delivery Controller in the Control Tower. Lettered blocks identify the functions performed and are described in the corresponding paragraphs below.

- a. TCCC Processing. The Tower Control Computer Complex (TCCC), through the TCCC Position Console, is the primary tool that controllers use to access the flight database.

NASSRS Requirement 3.2.9.C.2.

- b. Detect Overdue Or Unreported Aircraft. The Clearance Delivery Controller is alerted by TCCC through his TCCC Position Console when the difference between the current time and the expected time of arrival (ETA) at the destination terminal exceeds 30 minutes.

NASSRS Requirement 3.2.9.A.1.

- c. Assist In Search And Rescue. The Clearance Delivery Controller provides essential information contained on the original flight plan, last known position, last recorded heading, and weather conditions (if known).

NASSRS Requirement 3.2.9.C.1.

- d. Monitor For ELT Transmissions. Tower Controllers monitor 121.5/243.0 MHz for ELT transmissions.

NASSRS Requirement 3.2.9.D.1 and 2.

2.4 Correlation with Operational Requirements

Table 2-1 summarizes the correlation of the SAR operational requirements paragraphs of NAS-SR-1000 with the paragraphs describing the functions being performed by specialists/controllers/managers. All SAR paragraph numbers of NAS-SR-1000 are listed; paragraphs which are introductory in nature, do not state an explicit operational requirement, or reference other portions of NAS-SR-1000 are indicated with a dash. The fact that a correlation is shown between a requirements paragraph and a paragraph describing the specialist/controller/manager functions performed should not be construed as indicating that the requirement is completely fulfilled.

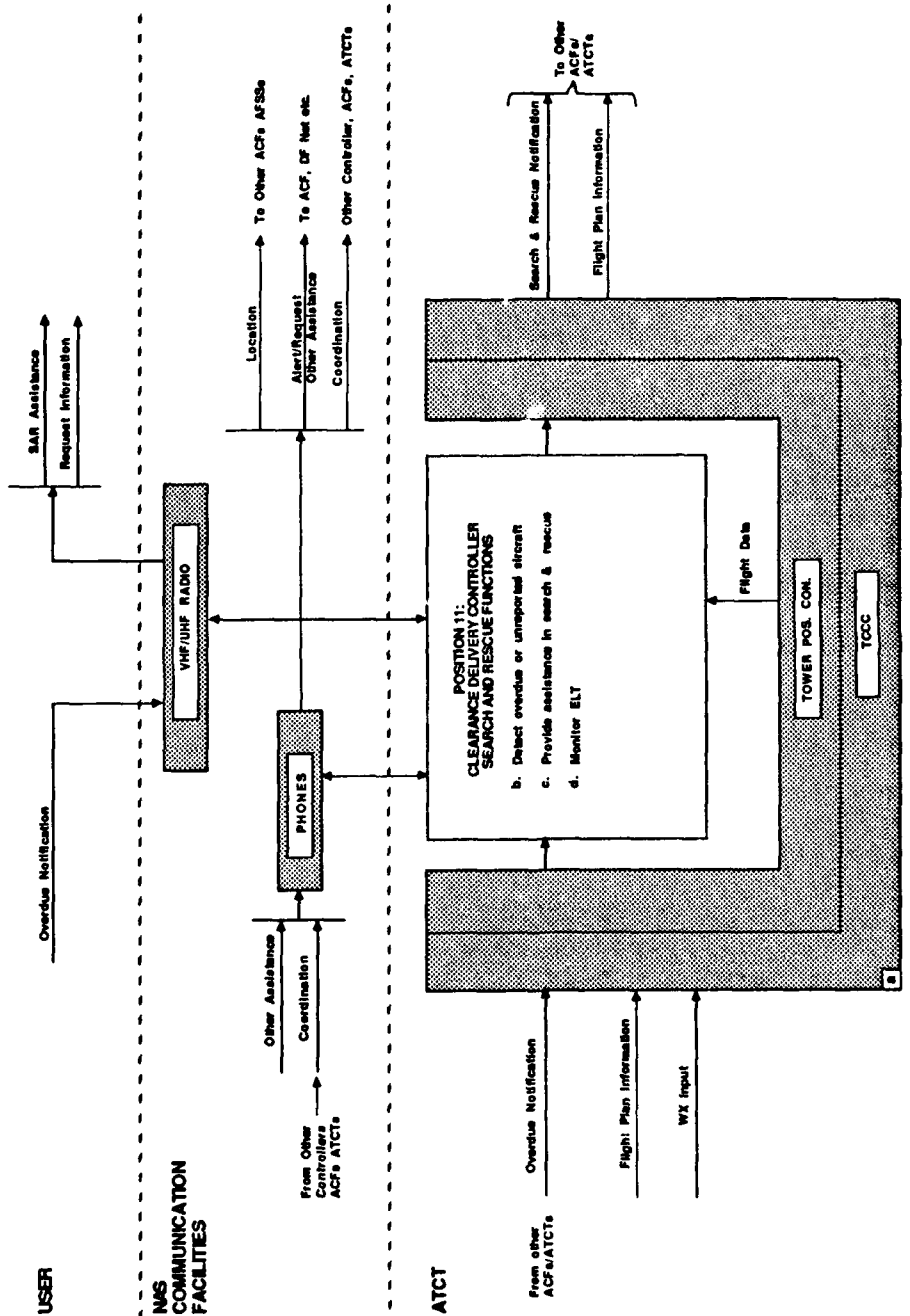

FIGURE 2-8
OPERATIONAL FLOW DIAGRAM, POSITION 11:
CLEARANCE DELIVERY CONTROLLER
PROVIDING SEARCH AND RESCUE ASSISTANCE

**TABLE 2-1
SEARCH AND RESCUE OPERATIONAL REQUIREMENTS CORRELATION**

	IN-FLIGHT SPECIALIST	DF SPECIALIST	NOTAM SPECIALIST	APPROP AND EN ROUTE CONTROLLER	AREA MANAGER	CLEAR DEL CONTROLLER
NAS-SR-1000 PARAGRAPH	2.3.1a 2.3.1b 2.3.1c 2.3.1d	2.3.2a 2.3.2b 2.3.2c 2.3.2d	2.3.3a 2.3.3b 2.3.3c 2.3.3d 2.3.3e 2.3.3f 2.3.3g 2.3.3h	2.3.4a 2.3.4b 2.3.4c 2.3.4d 2.3.4e 2.3.4f	2.3.5a 2.3.5b 2.3.5c 2.3.5d 2.3.5e	2.3.6a 2.3.6b 2.3.6c 2.3.6d 2.3.6e
3.2.9 General						
3.2.9 A Detect Overdue Aircraft						
.A1 ATC Overdue Notice						
.A2 AFSS Overdue Notice						
.A3 FIR Overdue Notice						
.B Initiate SAR Operations						
.C Assist in SAR Operations						
.C1 Provide Essential Info.	X X X X	X X	X X X X	X X X X	X X X X	X X X X
.C2 Retrieve Essential Info.	X					
.C3 Info. and Comm. Exchanged						
.C4 Process Airspace Res.						
.D Monitor of ELT						
.D1 ELT Frequency Monitor						
.D2 ELT Monitor by ATC/FACs	X X	X X				
.D3 Non-ATC Source Reports						
.D4 Geographic Coords of ELT						
.E Facilities To Be Contacted						
.F Messages For Transmission	X					
.F1 Message Preparation						
.F2 Message Review						
.G SAR Info. Exchange						
.G1 Real-Time Info. Exchange						
.G2 Input From Other Agencies						

2.5 Operational Sequence

Operational sequence diagrams have been developed to illustrate the interactions between users (pilots) and specialists/controllers for different categories/conditions of flight. These diagrams are general in nature and no effort has been made to depict a specific situation.

2.5.1 VFR Operational Sequence

Figure 2-9 illustrates a general sequence of operator/user interactions for SAR of an aircraft on a VFR flight plan.

An aircraft on a VFR flight plan is 30 minutes overdue at its destination airport (1). The NOTAM Specialist gets a flashing message on his/her screen that an aircraft is overdue (2). The NOTAM Specialist queries the database to find out more information about the aircraft (3). The NOTAM Specialist obtains essential information on: the aircraft's last recorded, or last known, position; last recorded heading; and weather information (4). Once this information has been reviewed, the NOTAM Specialist initiates a search of all adjacent flight plan area airports (including appropriate terminal area facilities and ACF Sectors) (5). The communication search does not locate the aircraft (6), the NOTAM Specialist then transmits the "QALQ" message to the departure station (9).

If the aircraft is found through the communications search (6) then the flight plan database (7) is updated (8) and the sequence ends.

Upon receipt of the "QALQ" message from the NOTAM Specialist the departure AFSS or the DUAT service forward any additional information (10) not previously sent and initiate a physical check of the appropriate airport (11). If the aircraft is found (12), the flight data base is updated (13) and the "QALQ" message is cancelled (14).

If the aircraft is not found (12), then the destination AFSS transmits all other information (15).

If the aircraft is still not located, the NOTAM Specialist transmits an Information Request (INREQ) Message (16) to the departure aerodrome, terminal areas, ACF Sectors within a 100-mile-wide corridor along its route of flight and the RCC. All stations receiving the INREQ message check their facility records (17, 18) and if the aircraft is found (19), the specialist updates the flight data base (20) and cancels the INREQ message (21). If the aircraft is not found (19) within one hour or the results of the INREQ are negative, the NOTAM Specialist transmits an Alert Notice (ALNOT) to all terminal areas, ACF within a 100-mile-wide corridor along its intended route of flight (22) and the RCC.

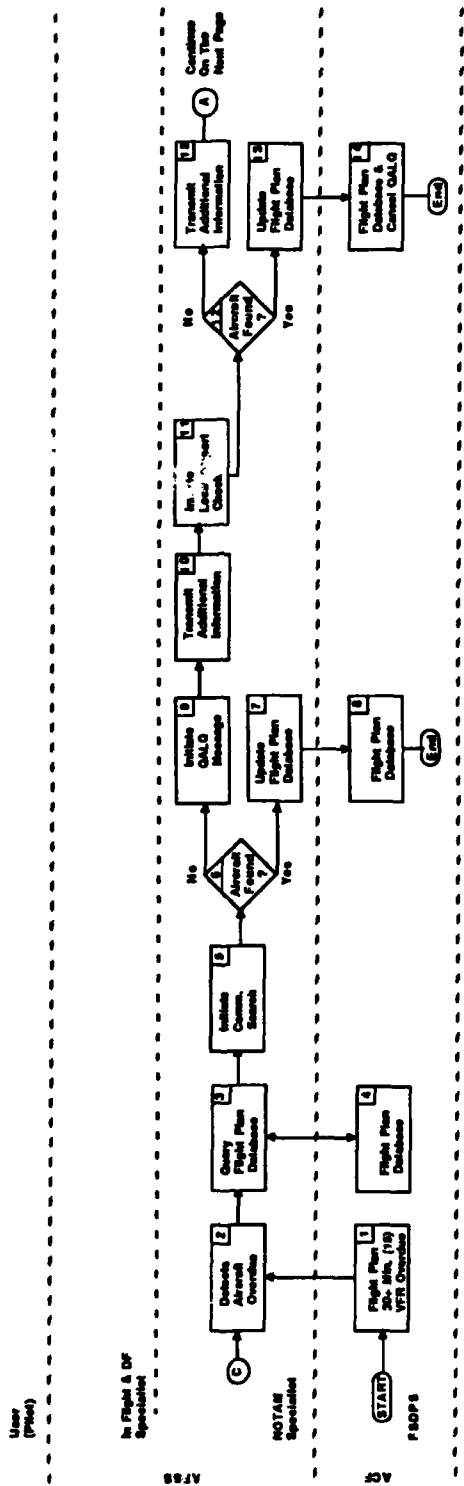

FIGURE 2-9
EN ROUTE VFR SEQUENCE DIAGRAM
FOR SEARCH AND RESCUE

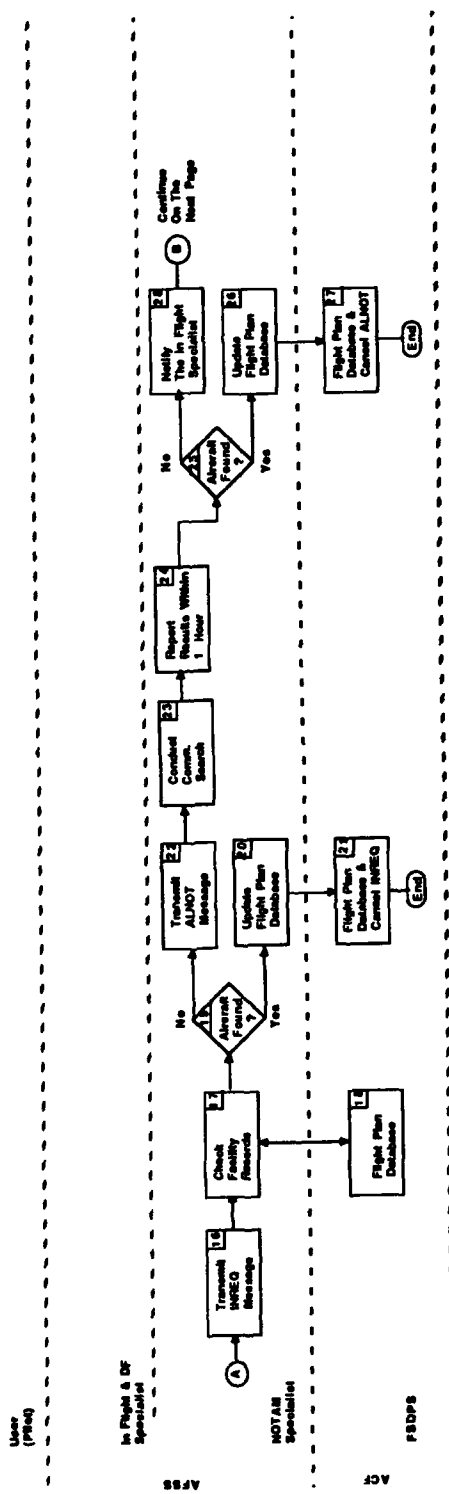

FIGURE 2-9 (Continued)
EN ROUTE VFR SEQUENCE DIAGRAM
FOR SEARCH AND RESCUE

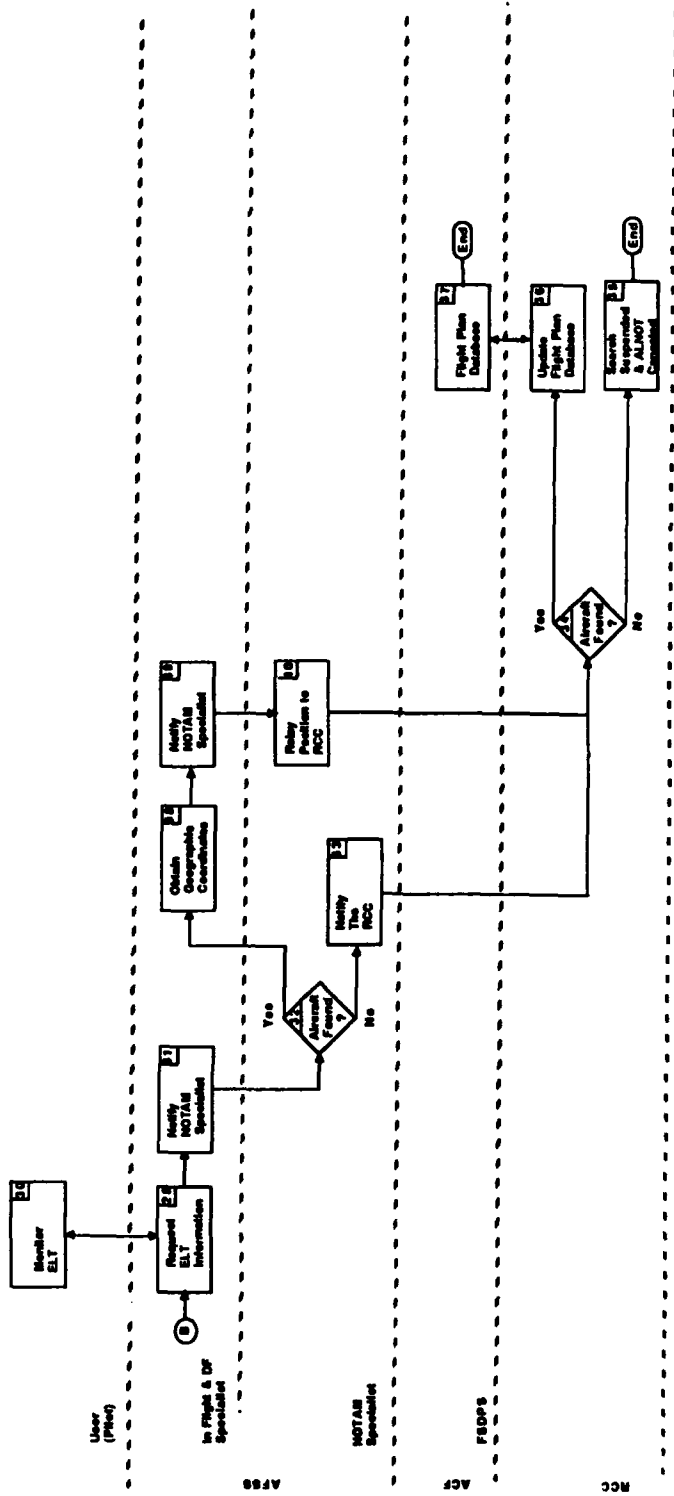

FIGURE 2-9 (Continued)
EN ROUTE VFR SEARCH AND RESCUE

Upon receipt of the ALNOT message, these facilities conduct a communications search of their respective areas (23) including notifying local law enforcement agencies to assist them. Within one hour of the ALNOT receipt, these facilities notify the NOTAM Specialist of the results of their search (24). If the aircraft is located (25), the flight plan data base is updated, all stations on its route of flight are notified, and the ALNOT message is cancelled (27).

2.5.1.1 If the aircraft is not located (25), the NOTAM Specialist notifies the In-Flight Specialist to request (28) aircraft traversing the area of the aircraft's last known position (29) to monitor 121.5/243.0 MHz for an ELT (30). The In-Flight Specialist notifies the NOTAM Specialist of results (31). If this search is unsuccessful (32) or it has been one hour since the ALNOT message was transmitted, the NOTAM Specialist notifies the RCC (33) and provide all pertinent information. If the aircraft is not located by RCC (34), the NAS/Air Traffic search is suspended (35), and all facilities are notified.

If the aircraft is located (34), the flight data base is updated (36) and the ALNOT message is terminated.

2.5.1.2 When notified by the NOTAM Specialist to ask for assistance in monitoring 121.5/243.0 MHz for an ELT, the In-Flight Specialist (32) gets the geographic coordinates of the downed aircraft through the use of the DF equipment (38) receiving the ELT signal or the signal from an aircraft orbiting the downed aircraft.

Once these coordinates are determined, the In-Flight Specialist notifies the NOTAM Specialist (39), who notifies the RCC (40).

2.5.2 IFR Operational Sequence

As the AFSS assists SAR operations for VFR aircraft, the ACF assists SAR operations for IFR aircraft. Since both Approach/Departure and En Route Controllers work within the ACF, and their roles in SAR are essentially the same, the following sequence as shown in Figure 2-10, is reflective of both types of controllers.

Upon being notified of an overdue or unreported aircraft (27), these controllers solicit pilot reports to monitor 121.5/243.0 MHz in the vicinity and notify supervisory personnel who then notify the Area Manager (28). The Area Manager queries the database (29) to review the aircraft's flight plan in an attempt to learn the aircraft's last recorded

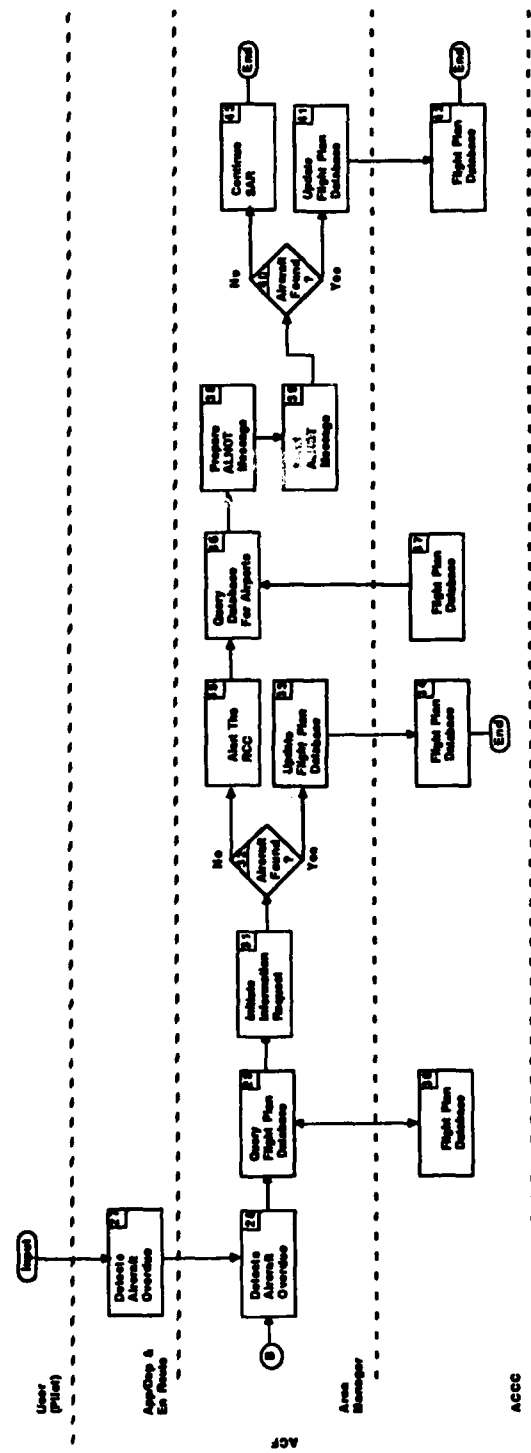

FIGURE 2-10
EN ROUTE IFR SEARCH AND RESCUE

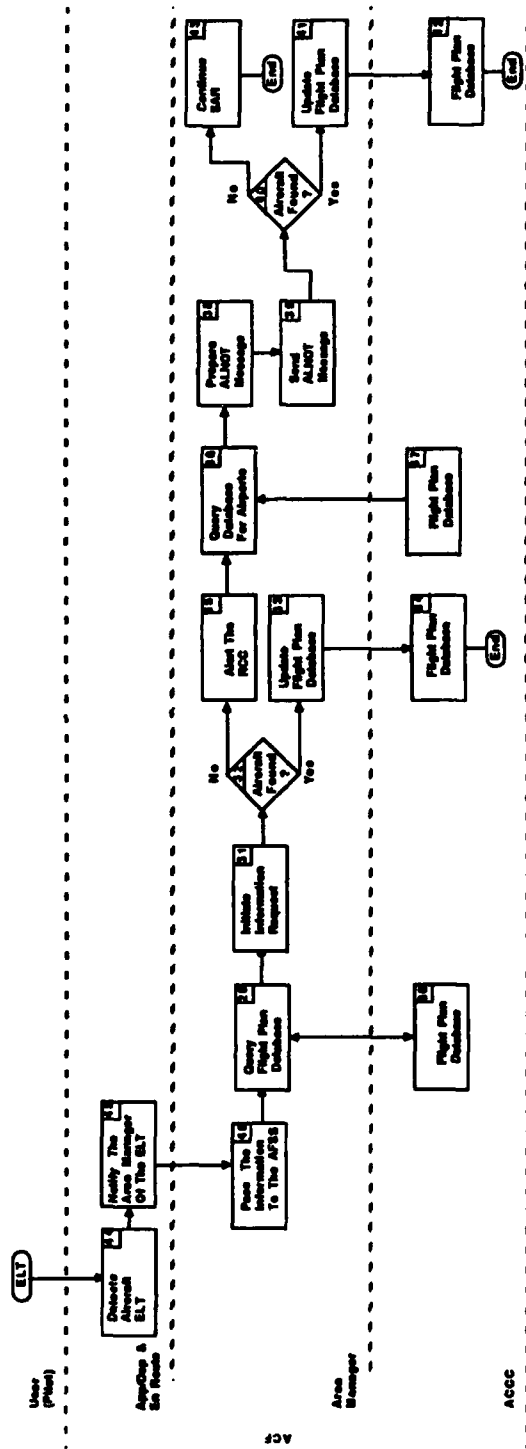

FIGURE 2-10 (Continued)
EN ROUTE IFR SEQUENCE DIAGRAM
FOR SEARCH AND RESCUE

or last known position (30). The Area Manager then calls adjacent facilities (31) to determine the aircraft's whereabouts. If an adjacent facility has found (32) the aircraft, then the flight database is updated (33) in the ACCC (34) and the search is terminated.

If the adjacent facilities cannot determine the whereabouts of the aircraft, then the Area Manager alerts the RCC with all the pertinent flight data (35). The Area Manager then retrieves a list of all aerodromes, terminal areas, and ACFs within a 100-mile-wide corridor along the projected route of the aircraft from the database (36) within the ACCC (37). The Area Manager prepares an Alert Notification (ALNOT) (38), reviews the message, and sends it to all aerodromes, and facilities within a 100-mile-wide corridor of the aircraft's projected path (39) and to the RCC. If the aircraft is found (40), the Area Manager updates the flight plan (41) in the database (42) and SAR the operation is terminated. If the aircraft has not been located within one hour after ALNOT issuance, it is thirty minutes past the aircraft's fuel exhaustion time, or the ALNOT search has been completed with negative results, then the Area Manager transfers responsibility for further search to the RCC (43). The ACF's assistance in SAR ends at this point.

2.5.2.1 Controllers in the ACF also monitor radios for an ELT transmission. In the event of an ELT signal (44), the controller notifies his/her Area Supervisor who notifies the Area Manager (45) The Area Manager attempts to determine the source by requesting assistance from the AFSS (46).

2.5.3 Terminal Area Operational Sequence

Figure 2-11 describes the responsibilities for controllers in the Air Traffic Control Towers (ATCT). When notified that an aircraft is overdue or unreported (47), he/she queries the database (48) in the TOCC (49) to determine the type of flight plan it was on (50). If the aircraft was on a VFR flight plan, they notify and assists the AFSS (51). If the aircraft was on an IFR flight plan, they alert and provide the ACF with (52) the pertinent flight information.

2.6 Operational Scenario

Figure 2-12 presents an operational scenario for a VFR aircraft in need of SAR assistance. It is similar to the operational sequence diagrams in Figure 2-9; however, this scenario represents the interactions between operators/users for a specific case. This scenario describes an aircraft on a VFR flight plan which is 30 minutes overdue. The NOTAM Specialist detects a flashing message on his work station terminal screen announcing that N2346J, a Piper Cherokee (PA-28) on a VFR flight plan from Milville, NJ to Leesburg, VA, is overdue at its destination airport (1).

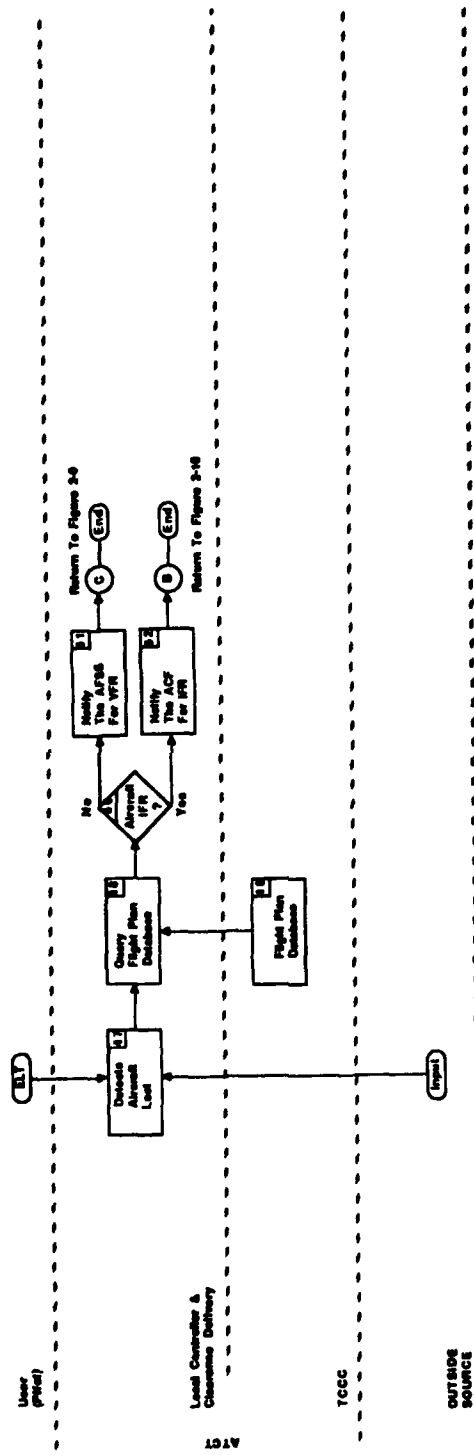

FIGURE 2-11
 TERMINAL AREA OPERATIONAL SEQUENCE DIAGRAM
 FOR SEARCH AND RESCUE

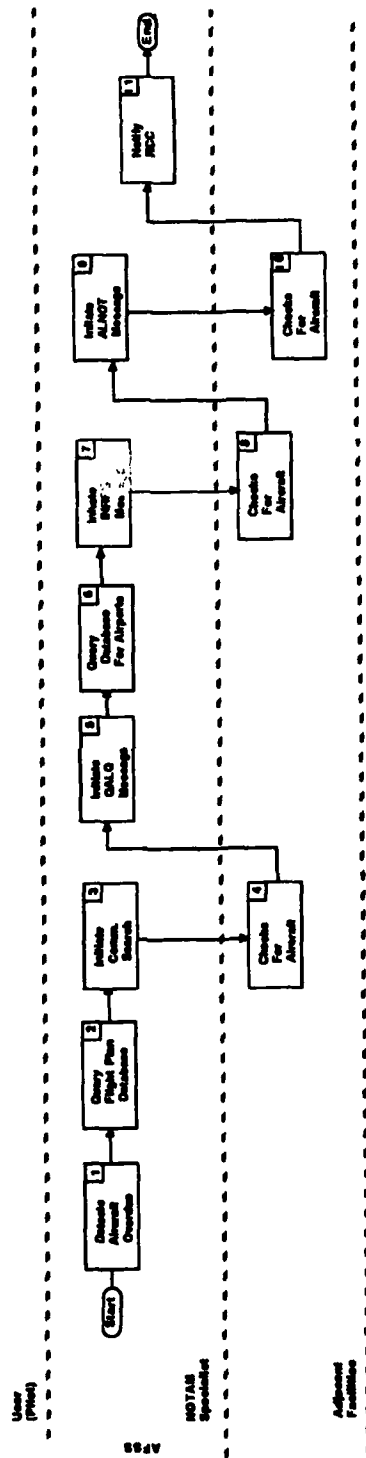

FIGURE 2-12
EN ROUTE VFR SCENARIO
FOR SEARCH AND RESCUE

The Notam Specialist queries the flight database to call up N2346J's flight plan to obtain further information as to last known position (2). With this information, the NOTAM Specialist initiates a communications search request to try to locate the aircraft (3). Adjacent facilities make an attempt to locate the aircraft (4) and the aircraft is not found. The NOTAM Specialist gets no further information (5) as to the whereabouts of N2346J he then initiates an initial information request ("QALQ" message) (6). The results of the "QALQ" message were negative (7) the NOTAM Specialist then calls up from his database a list of all aerodromes, terminal areas, and ACFs located within a 100-mile-wide corridor along N2346J's route of flight (8). The NOTAM Specialist then prepares, reviews, and transmits an Information Request (INREQ) to these adjacent aerodromes, terminal areas, ACF's, and the RCC (9). If N2346J is not found through the INREQ action (10), then the NOTAM Specialist initiates an Alert Notice (ALNOT) (11) to the facilities along the aircraft's route of flight (including the RCC) (12). If N2346J has not been found (13) within one hour after ALNOT issuance, the NOTAM Specialist relays all current pertinent information about the aircraft to RCC (14).

In the second scenario, Figure 2-13 presents an operational scenario for an aircraft on an IFR flight plan. It is similar to the operational sequence diagrams in Figure 2-10; between operators/users for a specific case. This scenario assumes that N124WV, a Beechcraft Kingair (BE-20) was cleared for approach into the Eastern West Virginia Regional Airport, Martinsburg, WV, by the Washington ACF. Since the weather at Martinsburg was rain showers and one half mile visibility, the Approach Controller at the Washington ACF wanted to ensure N124WV was on the ground safely at Martinsburg before clearing a second aircraft for approach. When N124WV failed to notify the control tower that he was inbound on the approach or he did not land within an appropriate amount of time, the Local Controller attempted radio contact. When no contact was established the Local Controller informs the Clearance Delivery Controller that N124WV is overdue (1). The Clearance Delivery Controller notifies the Approach Controller in the Washington ACF and asks if the aircraft came back to him (2). The Approach Controller states that N124WV has not called him but that he will check with the En Route Controller (3) on its status. When the En Route Controller states he does not have the aircraft, the Approach Controller notifies supervisory personnel who in turn notifies the Area Manager that N124WV is overdue (4). The Area Manager queries his database (5) to determine the aircraft's last known position. He then prepares, reviews, and transmits an Alert Notice (6) to determine if N124WV had diverted to another airport. Since no further information on N124WV's whereabouts is obtained, and the Area Manager alerts the RCC (7) to conduct a physical search.

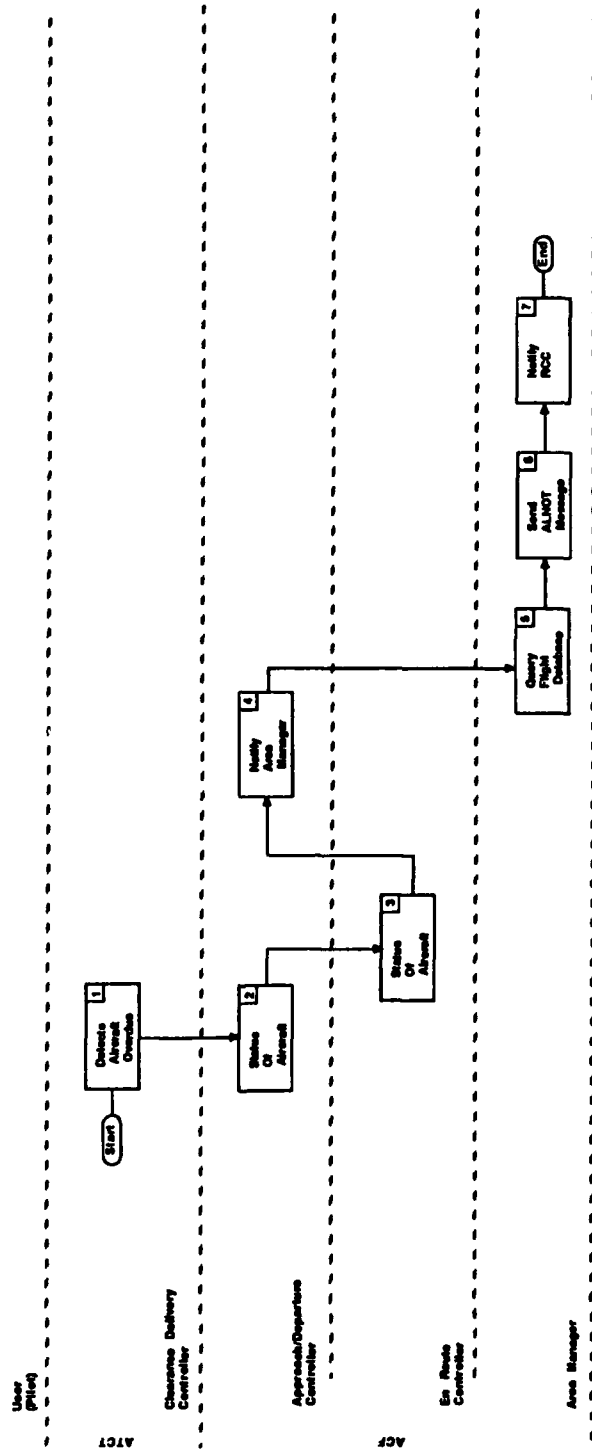

FIGURE 2-13
EN ROUTE IFR SCENARIO
FOR SEARCH AND RESCUE

REFERENCES

Federal Aviation Administration, Air Traffic Control, 7110.65E, Current edition, Washington, DC.

Federal Aviation Administration, Airman's Information Manual, Current edition, Washington, DC.

Federal Aviation Administration, Flight Service Station Procedures, 7110.10I, Current edition, Washington, DC.

Federal Aviation Administration (December 1986), National Airspace System Level I Design Document, NAS-DD-1000B, (Includes SCN-1 through SCN-11), Washington, DC.

Federal Aviation Administration (June 1988), National Airspace System Plan, Facilities, Equipment and Associated Development, Washington, DC.

Federal Aviation Administration (October 1986), National Airspace System Requirements Specification, NAS-SR-1000, (Includes SCN-1 through SCN-5), Washington, DC.

Federal Aviation Administration (December 1986), National Airspace System Specification, NAS-SS-1000, Washington, DC.

GLOSSARY

AERODROME - A defined area on land or water (including any buildings, installations, and equipment) intended to be used either wholly or in part for the arrival, departure, and movement of aircraft. Aerodromes may include airports, heliports, and other landing areas.

AIRCRAFT - Device/s that are used or intended to be used for flight in the air; when used in air traffic control terminology may include the flight crew.

ALNOT - A request originated by an Automated Flight Service Station (AFSS) or an Area Control Facility (ACF) for an extensive communications search for overdue, unreported, or missing aircraft.

AUTOMATED FLIGHT SERVICE STATION (AFSS) - A station that provides interactive alphanumeric and graphic workstations for the flight service specialists.

BEARING - The horizontal direction to or from any point, usually measured clockwise from true north, magnetic north, or some other reference point, through 360 degrees.

DIRECTION FINDER (DF) - A radio receiver equipped with a directional sensing antenna used to take bearings on a radio transmitter. Specialized radio direction finders are used in aircraft as air navigation aids. Others are ground-based, primarily to obtain a "fix" on a pilot requesting orientation assistance or to locate downed aircraft. A location "fix" is established by the intersection of two or more bearing lines plotted on a navigational chart using either two separately located Direction Finders to obtain a fix on an aircraft or by a pilot plotting the bearing indications of his DF on two separately located ground-based transmitters both of which can be identified on his chart.

DIAL UP ACCESS TERMINAL (DUAT) - The capability for direct user access terminals to file flight plans into the NAS and access weather information from the National Graphic Weather Display System

EMERGENCY - A safety condition of being threatened by serious and/or imminent danger which requires immediate or timely assistance.

EMERGENCY LOCATOR TRANSMITTER (ELT) - A radio transmitter attached to the aircraft structure which operates from its own power source on 121.5 MHz and 243.0 MHz. It aids in locating downed aircraft by radiating a downward sweeping audio tone, 2-4 times per second. It is designed to function without human action after an accident.

EN ROUTE - One of three phases of flight services (terminal, en route, oceanic). En route service is provided outside of terminal airspace and is exclusive of oceanic control.

EN ROUTE AIR TRAFFIC CONTROL SERVICES - Air traffic control services provided aircraft on IFR flight plans, generally by ARTCCs (ACF), when these aircraft are operating between departure and destination terminal areas. When equipment capabilities and controller workload permit, certain advisory/assistance services may be provided to VFR aircraft.

EN ROUTE MINIMUM SAFE ALTITUDE WARNING (E-MSAW) - A function of the NAS Stage A en route computer that aids the controller by providing an alert when a tracked aircraft is below or predicted by the computer to go below a predetermined minimum IFR altitude.

FIX - A geographical position that is determined by visual reference to the surface, by reference to one or more radio NAVAIDS, by celestial plotting, or by another navigational device.

FLIGHT INFORMATION REGION (FIR) - An airspace of defined dimensions within which Flight Information Service and Alerting Service are provided.

1. **Flight Information Service** - A service provided for the purpose of giving advice and information useful for the safe and efficient conduct of flights.
2. **Alerting Service** - A service provided to notify appropriate organizations regarding aircraft in need of search and rescue aid and assist such organizations as required.

FLIGHT PATH - A line, course, or track along which an aircraft is flying or intended to be flown.

FLIGHT PLAN - Specified information relating to the intended flight of an aircraft that is filed orally or in writing with an ATC facility.

FLIGHT SERVICE STATION (FSS) - Air traffic facilities which provide pilot briefing, en route communications, and VFR search and rescue services; assist lost aircraft and aircraft in emergency situations; relay ATC clearances; originate Notices to Airmen; broadcast aviation weather and NAS information; receive and process IFR flight plans; and monitor NAVAIDS. In addition, at selected locations, FSSs provide En Route Flight Advisory Service (Flight Watch), take weather observations, issue airport advisories, and advise Customs and Immigration of transborder flights.

HAZARDOUS AREA REPORTING SERVICE - Flight monitoring for VFR aircraft crossing large bodies of water, swamps, and mountains. This service is provided for the purpose of expeditiously alerting SAR facilities when required. Radio contacts are desired at least every 10 minutes. If contact is lost for more than 15 minutes, SAR will be alerted.

INSTRUMENT FLIGHT RULES (IFR) - Rules governing the procedures for conducting instrument flight. Also a term used by pilots and controllers to indicate type of flight plan.

IFR AIRCRAFT/IFR FLIGHT - An aircraft conducting flight in accordance with instrument flight rules.

IFR CONDITIONS - Weather conditions below the minimum for flight under visual flight rules.

INFORMATION REQUEST (INREQ) - A request originated by an AFSS for information concerning an overdue VFR aircraft.

NATIONAL AIRSPACE SYSTEM (NAS) - As used herein the NAS describes the FAA facilities, hardware, and software that are a predominant part of the NAS infrastructure and the personnel who operate and maintain that equipment to provide services to the user.

NATIONAL SEARCH AND RESCUE PLAN - An interagency agreement which provides for the effective utilization of all available facilities in all types of search and rescue missions.

NOTICE TO AIRMEN (NOTAM) - A notice containing information (not known sufficiently in advance to publicize by other means) concerning the establishment, condition, or change in any component (facility, service, procedure, or hazard in the National Airspace System) the timely knowledge of which is essential to personnel concerned with flight operations.

QALQ MESSAGE - An initial informational inquiry made from a Flight Service Station on the whereabouts of a VFR aircraft.

REMOTE AREAS - Sparsely populated areas such as mountains, swamps, and large bodies of water.

REPORTING POINT - A geographical location in relation to which the position of an aircraft is reported.

RESCUE COORDINATION CENTER (RCC) - A search and rescue (SAR) facility equipped and manned to coordinate and control SAR operations in an area designated by the SAR plan. The U.S. Coast Guard and the U.S. Air Force have responsibility for the operation of RCCs.

ROUTE - A defined path, consisting of one or more courses in a horizontal plane, which aircraft traverse over the surface of the earth.

SEARCH AND RESCUE/SAR - A service which seeks missing aircraft and assists those found to be in need of assistance. It is a cooperative effort using the facilities and services of available Federal, state, and local agencies.

SPECIALIST - The internal individual or group who provides service through the NAS (e.g., controllers, engineers, maintenance, and management personnel).

SURVEILLANCE - The detection, location, and tracking of aircraft within NAS airspace for the purposes of control, separation, and identification. Surveillance systems are electronic in nature; visual methods are purposely excluded. In the case of dependent surveillance, the aircraft provides all flight information. Surveillance systems are differentiated as independent, independent cooperative, and dependent:

1. Independent Surveillance - A system which requires no airborne compatible equipment
2. Independent Cooperative Surveillance - A system which requires airborne compatible equipment (e.g., ATCRBS, Mode S)
3. Dependent Surveillance - A system which requires input from navigation equipment aboard the aircraft either via a data link (e.g., LOFF) or via voice transmission (pilot reports)

TERMINAL AREA - A general term used to describe airspace in which approach control service or airport traffic control service is provided.

TERMINAL AREA FACILITY - A facility providing air traffic control service for arriving and departing IFR, VFR, Special VFR, Special IFR aircraft and, on occasion, en route aircraft.

TOWER/AIRPORT TRAFFIC CONTROL TOWER - A terminal facility that uses air-ground radio communications, visual signaling, and other devices to provide ATC services to aircraft operating in the vicinity of an airport or on the movement area. Authorizes aircraft to land or takeoff at the airport controlled by the tower or to transit the airport traffic area regardless of flight plan or weather conditions (IFR or VFR). A tower may also provide approach control services.

USER - The external individual or group that receive services from the NAS (e.g., Pilot, Air Carrier, General Aviation, Military, Law Enforcement Agencies, etc.).

VISUAL FLIGHT RULES (VFR) - Rules that govern the procedures for conducting flight under visual conditions. The term "VFR" is also used in the United States to indicate weather conditions that are equal to or greater than minimum VFR requirements. In addition, it is used by pilots and controllers to indicate the type of flight plan.

VFR AIRCRAFT/VFR FLIGHT - An aircraft conducting flight in accordance with visual flight rules or operating on a Special VFR clearance.

VFR CONDITIONS - Weather conditions equal to or better than the minimum for flight under visual flight rules.

VISUAL METEOROLOGICAL CONDITIONS (VMC) - Meteorological conditions expressed in terms of visibility, distance from cloud, and ceiling equal to or better than the specified minima.

ACRONYMS/ABBREVIATIONS

ACRONYM

MEANING

ACCC	Area Control Computer Complex
ACF	Area Control Facility
AFSS	Automated Flight Service Station
ALNOT	Alert Notice
ALTRV	Altitude Reservation
ARINC	Aeronautical Radio Incorporated
ARTCC	Air Route Traffic Control Center
ATC	Air Traffic Control
ATOCC	Air Traffic Control Command Center
ATCT	Air Traffic Control Tower
AUTODIN	Automatic Digital Network
AUTOVON	Automatic Voice Network
AWP	Aviation Weather Processor
CARF	Central Altitude Reservation Function
CWA	Center Weather Advisory
DF	Direction Finder
DME	Distance Measuring Equipment
DOD	Department of Defense
DOT	Department of Transportation
DUAT	Dial Up Access Terminal
EFAS	EN Route Flight Advisory Service
ELT	Emergency Locator Transmitter
FAA	Federal Aviation Administration
FAC	Facilities
FSAS	Flight Service Automation System
FSDPS	Flight Service Data Processing System
FSS	Flight Service Station
IFR	Instrument Flight Rules
INREQ	Information Request
NADIN	National Airspace Data Interchange Network
NAS	National Airspace System
NASP	National Airspace System Plan
NAVAID	Navigational Aid
NAWPF	National Aviation Weather Processing Facility
NEXRAD	Next Generation Weather Radar
NOTAM	Notice(s) to Airmen

NTIA	National Telecommunications and Information Administration
NWS	National Weather Service
PIREP	Pilot Report
QALQ	Initial Information Request Message
RCC	Rescue Coordination Center
RCF	Remote Communication Facility
SAR	Search and Rescue
SIGMET	Significant Meteorological Condition
TACAN	Tactical Aircraft Control and Navigation
TCC	Tower Control Computer Complex
TMU	Traffic Management Unit
UHF	Ultra High Frequency
VFR	Visual Flight Rules
VHF	Very High Frequency
VMC	Visual Meteorological Conditions
VOR	Very High Frequency Omnidirectional Radio
VORTAC	Collocated VOR and TACAN
WS	Weather Service
WST	Convective SIGMET
WX	Weather