

2

AD-A207 084

INTERIM REPORT

FEBRUARY 1988

EVT 5-88

AD-A207 084

ENGINEERING TEST OF THE
M2A2 PALLET ADAPTER
AND TOP LIFT FRAME

DTIC
ELECTE
APR 25 1989
S E D

Prepared for:
U.S. Army Armament Research,
Development and Engineering Center
ATTN: SMCAR-AEP
Picatinny Arsenal, NJ 07801-5000

Distribution Unlimited



EVALUATION DIVISION
SAVANNA, ILLINOIS 61074-9639

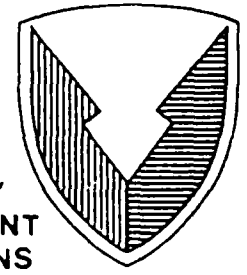

US ARMY
ARMAMENT
MUNITIONS
CHEMICAL COMMAND
US ARMY DEFENSE AMMUNITION
CENTER AND SCHOOL

89 4 25 035

AVAILABILITY NOTICE

A copy of this report is furnished each attendee on automatic distribution. Additional copies or authority for reprinting may be obtained by written request from Director, U.S. Army Defense Ammunition Center and School.
ATTN: SMCAC-DEV, Savanna, IL 61074-9639.

DISTRIBUTION INSTRUCTIONS

Destroy this report when no longer needed. Do not return.

* * *

Citation of trade names in this report does not constitute an official endorsement.

* * *

The information contained herein will not be used for advertising purposes.

REPORT DOCUMENTATION PAGE				Form Approved OMB No. 0704-0188	
1a. REPORT SECURITY CLASSIFICATION UNCLASSIFIED		1b. RESTRICTIVE MARKINGS			
2a. SECURITY CLASSIFICATION AUTHORITY		3. DISTRIBUTION / AVAILABILITY OF REPORT			
2b. DECLASSIFICATION / DOWNGRADING SCHEDULE					
4. PERFORMING ORGANIZATION REPORT NUMBER(S) EVT 5-88		5. MONITORING ORGANIZATION REPORT NUMBER(S)			
6a. NAME OF PERFORMING ORGANIZATION U.S. Army Defense Ammunition Center and School		6b. OFFICE SYMBOL (if applicable) SMCAC-DEV	7a. NAME OF MONITORING ORGANIZATION		
6c. ADDRESS (City, State, and ZIP Code) Savanna, IL 61074-9639		7b. ADDRESS (City, State, and ZIP Code)			
8a. NAME OF FUNDING / SPONSORING ORGANIZATION U.S. Army Armament Research, Development and Engineering Center		8b. OFFICE SYMBOL (if applicable) SMCAR-AEP	9. PROCUREMENT INSTRUMENT IDENTIFICATION NUMBER		
8c. ADDRESS (City, State, and ZIP Code) Picatinny Arsenal, NJ 07801-5000		10. SOURCE OF FUNDING NUMBERS			
		PROGRAM ELEMENT NO.	PROJECT NO.	TASK NO.	WORK UNIT ACCESSION NO.
11. TITLE (Include Security Classification) Engineering Test of the M2A2 Pallet Adapter and Top Lift Frame					
12. PERSONAL AUTHOR(S) Quinn D. Hartman					
13a. TYPE OF REPORT INTERIM		13b. TIME COVERED FROM Feb 88 TO _____		14. DATE OF REPORT (Year, Month, Day) 1988 April 6	15. PAGE COUNT 42
16. SUPPLEMENTARY NOTATION					
17. COSATI CODES			18. SUBJECT TERMS (Continue on reverse if necessary and identify by block number)		
FIELD	GROUP	SUB-GROUP			
19. ABSTRACT (Continue on reverse if necessary and identify by block number)					
<p>The U.S. Army Defense Ammunition Center and School (USADACS), Evaluation Division (SMCAC-DEV), has been tasked by the U.S. Army Armament Research, Development and Engineering Center, SMCAR-AEP, Picatinny Arsenal, NJ, to develop, implement, and test unitization procedures for M2A2 containers. This report contains the procedures, results, and recommendations from the MIL-STD-1660 test that was conducted on the test pallet of M2A2 containers. As a result of the performance of the test pallet, recommendations for redesign of the pallet adapter and top lift and additional testing evolved.</p>					
20. DISTRIBUTION / AVAILABILITY OF ABSTRACT <input checked="" type="checkbox"/> UNCLASSIFIED/UNLIMITED <input type="checkbox"/> SAME AS RPT. <input type="checkbox"/> DTIC USERS			21. ABSTRACT SECURITY CLASSIFICATION UNCLASSIFIED		
22a. NAME OF RESPONSIBLE INDIVIDUAL THOMAS J. MICHELS, Chief, Evaluation Division		22b. TELEPHONE (Include Area Code) AV 585-8080 (815)		22c. OFFICE SYMBOL SMCAC-DEV	

U.S. ARMY DEFENSE AMMUNITION CENTER AND SCHOOL
 Evaluation Division
 Savannah, IL 61074-9639

REPORT NO. EVT 5-88
 ENGINEERING TEST OF THE M2A2 PALLET ADAPTER AND TOP LIFT FRAME

TABLE OF CONTENTS

PART	PAGE NO.
1. INTRODUCTION	1-1
A. BACKGROUND	1-1
B. AUTHORITY	1-1
C. OBJECTIVE	1-1
2. ATTENDEES.	2-1
3. TEST PROCEDURES.	3-1
4. TEST EQUIPMENT	4-1
5. TEST RESULTS	5-1
6. CONCLUSIONS AND RECOMMENDATIONS	6-1
7. PHOTOGRAPHS.	7-1
8. DRAWINGS	8-1

Accession For	
NTIS GRA&I	<input checked="" type="checkbox"/>
DTIC TAB	<input type="checkbox"/>
Unannounced	<input type="checkbox"/>
Justification	
By _____	
Distribution/	
Availability Codes	
Dist	Avail and/or Special
A-1	

PART 1

INTRODUCTION

A. BACKGROUND. The U.S. Army Defense Ammunition Center and School, Evaluation Division, was tasked by the U.S. Army Armament Research, Development and Engineering Center, SMCAR-AEP, to develop, test, and evaluate a unitized load of M2A2 containers. To achieve this task, a pallet adapter, intermediate frames, and top lift frame were designed and fabricated to fit a standard metal pallet. (See Drawings.) For this first test, the pallet was only loaded with three levels of containers instead of five, and the intermediate frames were not included in the load. The objective of the first test was to locate any structural weaknesses in the pallet adapter and top lift frame before the prototype pallets were manufactured. Evaluation of the test pallet was done using the procedure outlined in MIL-STD-1660, Design Criteria for Ammunition Unit Loads.

B. AUTHORITY. This test was conducted in accordance with mission responsibilities delegated by the U.S. Army Armament, Munitions and Chemical Command (AMCCOM), Rock Island, IL.

C. OBJECTIVE. The objective of these tests is to assess the capability of the pallet adapter and top lift frame to meet Army functional/operational requirements for MIL-STD-1660, Design Criteria for Ammunition Unit Loads.

PART 2

ATTENDEES

Quinn Hartman
Test Engineer

U.S. Army Defense Ammunition Center and School
ATTN: SMCAC-DEV
Savanna, IL 61074-9639
AV 585-8989

Ken Dreier
Design Engineer

U.S. Army Defense Ammunition Center and School
ATTN: SMCAC-DEV
Savanna, IL 61074-9639
AV 585-8083

PART 3

TEST PROCEDURES

The test procedures outlined in this section were extracted from MIL-STD-1660, Design Criteria for Ammunition Unit Loads, 8 April 1977. This standard identifies nine steps that a unitized load must undergo if it is considered to be acceptable. The five tests that were conducted on the test pallet are synopsized below.

1. STACKING TESTS. The unit load shall be loaded to simulate a stack of identical unit loads stacked 16 feet high, for a period of one hour. This stacking load is simulated by subjecting the unit load to a compression of weight equal to an equivalent 16-foot stacking height. The compression load is calculated in the following manner. The unit load weight is divided by the unit load height in inches and multiplied by 192. The resulting number is the equivalent compressive force of a 16-foot-high load.

2. REPETITIVE SHOCK TEST. The repetitive shock test shall be conducted in accordance with Method 5019, Federal Standard 101. The test procedure is as follows. The test specimen shall be placed on, but not fastened to, the platform. With the specimen in one position, vibrate the platform at 1/2-inch amplitude (1-inch double amplitude) starting at a frequency of about 3 cycles per second. Steadily increase the frequency until the package leaves the platform. The resonant frequency is achieved when a 1/16-inch-thick feeler may be momentarily slid freely between every point on the specimen in contact with

the platform at some instance during the cycle or a platform acceleration achieves one plus or minus zero point one G. Midway into the testing period the specimen shall be rotated 90 degrees and the test continued for the duration. Unless failure occurs, the total time of vibration shall be two hours if the specimen is tested in one position; and, if tested in more than one position, the total time shall be three hours.

3. EDGEWISE DROP TEST. This test shall be conducted by using the procedures of Method 5008, Federal Standard 101. The procedure for the Edgewise Drop (Rotational) Test is as follows: The specimen shall be placed on its bottom with one end of the base of the container supported on a sill nominally 6 inches high. The height of the sill shall be increased if necessary to ensure that there will be no support for the base between the ends of the container when dropping takes place, but should not be high enough to cause the container to slide on the supports when the dropped end is raised for the drops. The unsupported end of the container shall then be raised and allowed to fall freely to the concrete, pavement, or similar underlying surface from a prescribed height. Unless otherwise specified, the height of drop for level A protection shall conform to the following tabulation.

<u>GROSS WEIGHT NOT EXCEEDING</u>	<u>DIMENSIONS ON ANY EDGE NOT EXCEEDING</u>	<u>HEIGHT OF DROP LEVEL A PROTECTION</u>
600 lbs.	72 inches	36 inches
3,000 lbs.	no limit	24 inches
no limit	no limit	12 inches

4. SLING COMPATIBILITY TEST. Unit loads utilizing special design for

nonstandard pallets shall be lifted, slung, lowered, and otherwise handled as necessary using slings of the types normally used for handling the unit loads under consideration. Slings shall be easily attached and removed. Danger of slippage or disengagement when load is suspended shall be cause for rejection of the unit load.

5. IMPACT TEST. This test shall be conducted by using the procedure of Method 5023, Incline-Impact Test of Federal Standard 101. The procedure for the Incline-Impact Test is as follows: The specimen shall be placed on the carriage with the surface or edge which is to be impacted projecting at least 2 inches beyond the front end of the carriage. The carriage shall be brought to a predetermined position on the incline and released. If it is desired to concentrate the impact on any particular position on the container, a 4x4-inch timber may be attached to the bumper in the desired position before the test. No part of the timber shall be struck by the carriage. The position of the container on the carriage and the sequence in which surfaces and edges are subjected to impacts may be at the option of the testing activity and will depend upon the objective of the tests. When the test is to determine satisfactory requirements for a container or pack, and, unless otherwise specified, the specimen shall be subjected to one impact on each surface that has each dimension less than 9.5 feet. Unless otherwise specified, the velocity at time of impact shall be 7 feet per second.

PART 4

TEST EQUIPMENT

1. TEST SPECIMEN.

- a. Drawing Number: AC200000514
- b. Width: 37-1/4 inches
- c. Length: 47-1/2 inches
- d. Height: 28-3/8 inches
- e. Weight: 1,990 pounds

2. COMPRESSION TESTER.

- a. Manufacturer: Ormond Manufacturing
- b. Platform: 60 inches by 60 inches
- c. Compression Limit: 50,000 pounds
- d. Tension Limit: 50,000 pounds

3. TRANSPORTATION SIMULATOR.

- a. Manufacturer: Gaynes Laboratory
- b. Capacity: 6,000-pound pallet
- c. Displacement: 1/2-inch Amplitude
- d. Speed: 50 to 400 rpm
- e. Platform: 5 foot by 8 foot

4. INCLINED RAMP.

- a. Manufacturer: Conbur Incline
- b. Type: Impact Tester
- c. Grade: 10 percent Incline
- d. Length: 12-foot Incline

PART 5

TEST RESULTS

1. STACKING TEST.

Pallet Weight - 1,990 lbs.
Pallet Height - 28-3/8 in.
Test Load - 13,500 lbs.

The test pallet was loaded to 13,500 pounds compression for a period of one hour. At the end of the one hour period, the compression load had decreased to 11,300 pounds, but no measurable compression was noted in the load.

2. REPETITIVE SHOCK TEST.

The test pallet successfully passed both the longitudinal and lateral transportation simulation. Duration of the test was 90 minutes for each orientation of the pallet. In order to achieve the required 1/16-inch clearance between the pallet and the Transportation Simulator bed, the equipment was operated at 235 rpm for the longitudinal orientation and 215 rpm for the lateral orientation. At the completion of the test, it was noted that three of the hinge pins on the plastic M2A2 cans had vibrated out several inches. (See Photos)

3. EDGEWISE DROP TEST.

Each side of the pallet base was placed on a beam displacing it 6 inches above the floor. The opposite side was raised to a height of 24 inches above the floor and then dropped. This process was repeated in a clockwise direction until all four sides of the pallet had been tested. During the first and third

drops, no damage was sustained by the pallet adapter or load, but the outer edge of the skid opposite the displacing beam was bent. On the second and fourth drops, the pallet and pallet adapter were bent along the length of the skids. The bending of the pallet created a gap between the top lift and the center set of containers.

4. SLING TEST.

The sling test consisted of five different lifting configurations using a top lift adapter and a four legged sling. The configurations used for this test consisted of a four corner, three corner, two alternate corners, two adjacent corners, and a single corner lift. No damage was sustained by the pallet or the top lift adapter from the sling test.

5. IMPACT TEST.

The incline impact tester was set to allow the pallet to travel 8 feet before impacting the bumper of the impact tester. In between impacts, the pallet was rotated in a clockwise direction until all four sides of the pallet had been impacted. During the first impact, the outer edges of the top lift frame that are perpendicular to the impacting surface were bent outward. On the second and fourth impacts, the containers compressed together towards the impact wall leaving a large gap between the bands and the end containers. Also, the second and fourth impacts caused several of the center cans to rack up and out of position. Finally, the third impact caused no additional damage to the pallet.

PART 6

CONCLUSIONS AND RECOMMENDATIONS

1. CONCLUSIONS. The test pallet failed to pass all phases of the MIL-STD-1660 criteria for ammunition unit loads. The only major damage sustained during the test was bending in the pallet and pallet adapter during the second and third drops of the edgewise drop test and bending in the top lift frame during the first impact of the incline impact test. The bending of the pallet and top lift frame was severe enough that the containers were allowed to rack out of position and nearly fall from the pallet during the inclined impact test. Also during the test, it was noted that three of the hinge pins of the plastic M2A2 containers had vibrated out several inches during the repetitive shock test. (S)

2. RECOMMENDATIONS. Since the performance of the test pallet was marginal, it is recommended that further testing be performed to verify the suitability of the pallet adapter and top lift frame for transportation of plastic M2A2 containers. The pallet adapter and top lift frame should be redesigned prior to additional testing to eliminate the bending that occurred during the edgewise drop test and inclined impact. The redesign should include provisions for strengthening of the pallet adapter and top lift frame and also a reduction in the size of the pallet adapter and top lift frame to reduce the racking of the containers.

PART 7
PHOTOGRAPHS



DEFENSE AMMUNITION CENTER AND SCHOOL · SAVANNA, IL

Photograph No. 1. Test pallet in the Compression Tester.



	DEFENSE AMMUNITION CENTER AND SCHOOL · SAVANNA, IL	
Photograph No. 2 Test pallet in the Transportation Simulator in Lateral Orientation.		

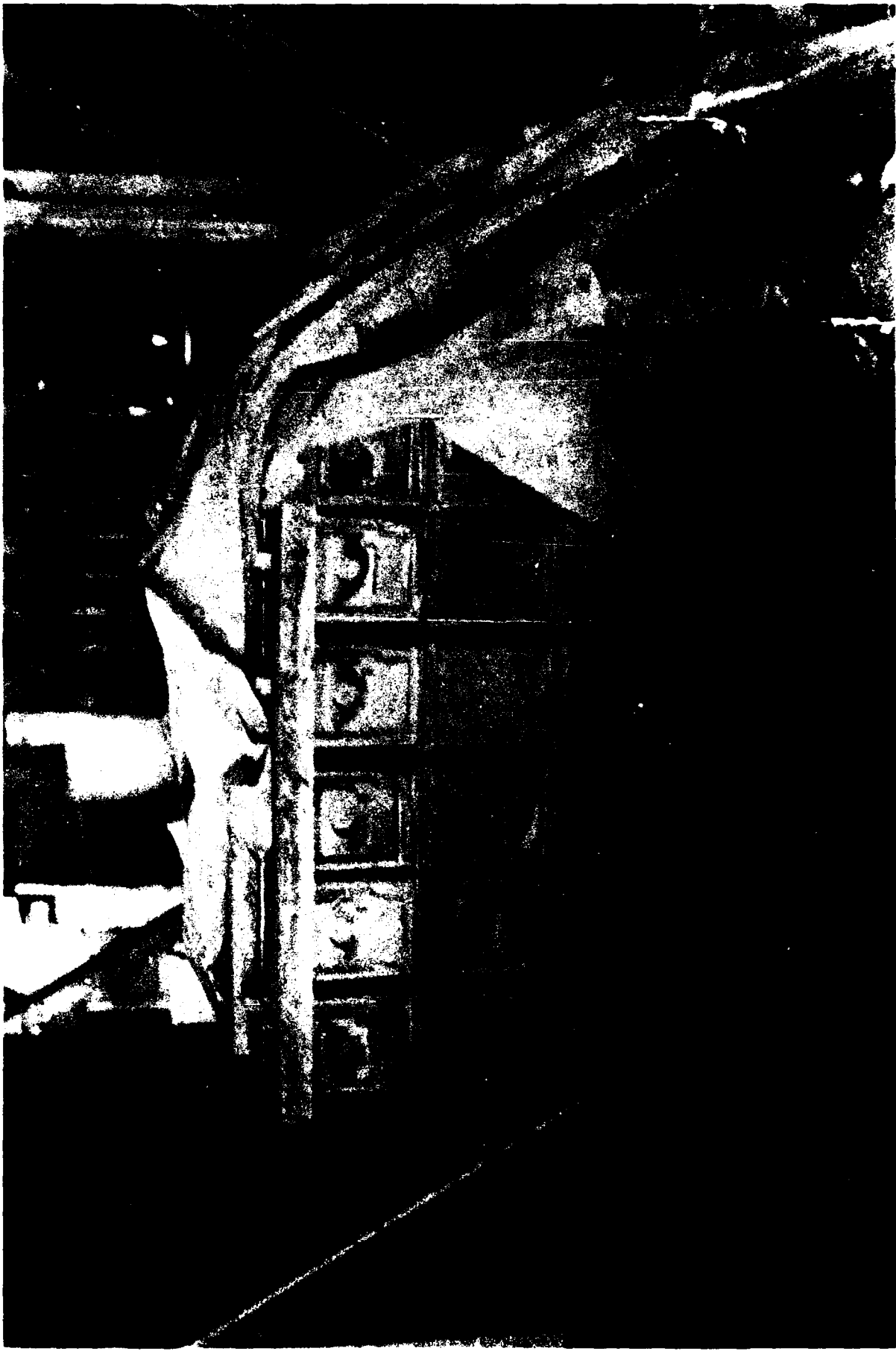

DEFENSE AMMUNITION CENTER AND SCHOOL · SAVANNAH, IL

Photograph No. 3. Test pallet in the Transportation Simulator in Longitudinal Orientation.

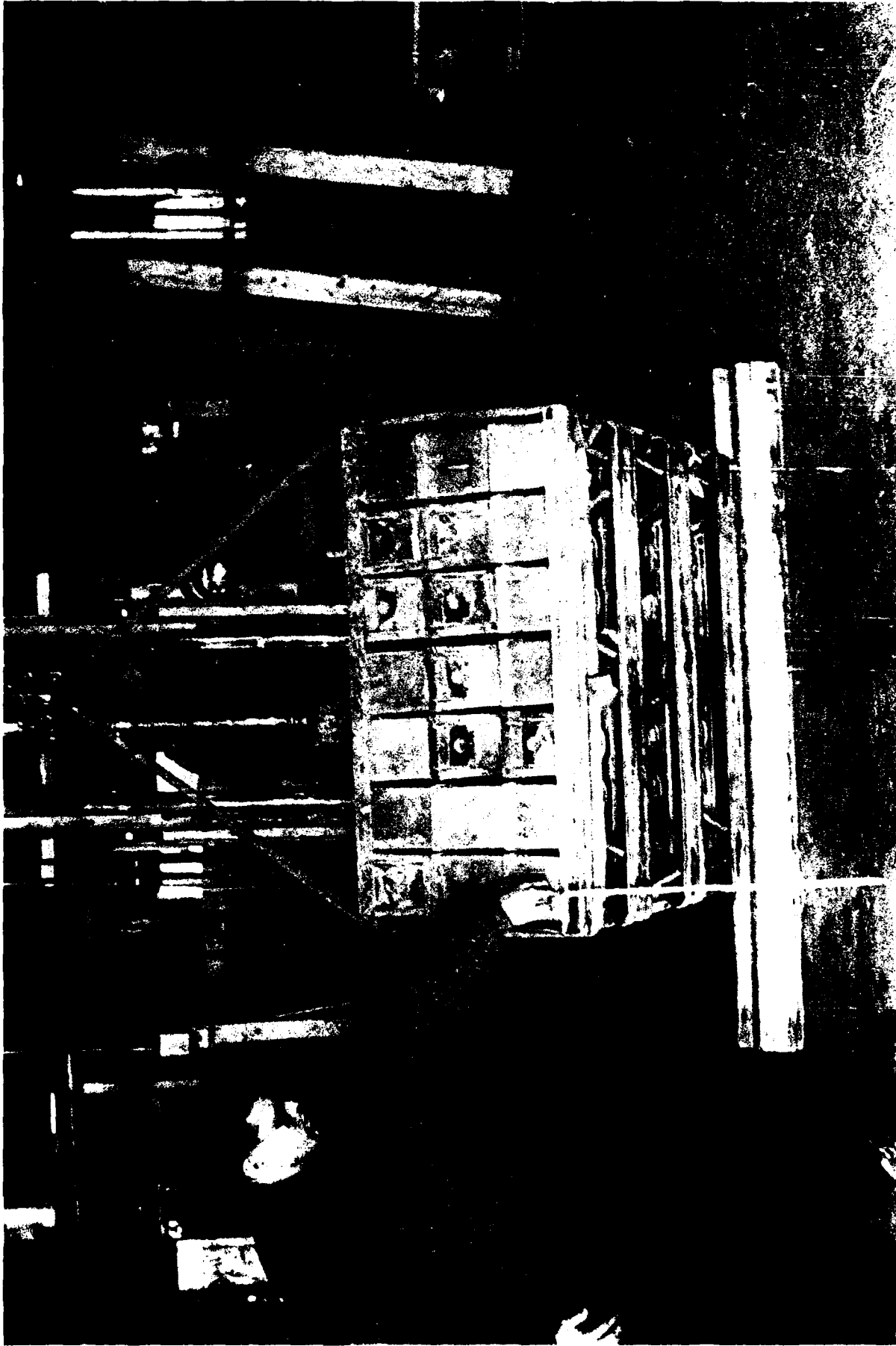

DEFENSE AMMUNITION CENTER AND SCHOOL SAVANNAH, IL

Photograph No. 4. Test pallet being raised 24 inches prior to the first edgewise rotational drop test.

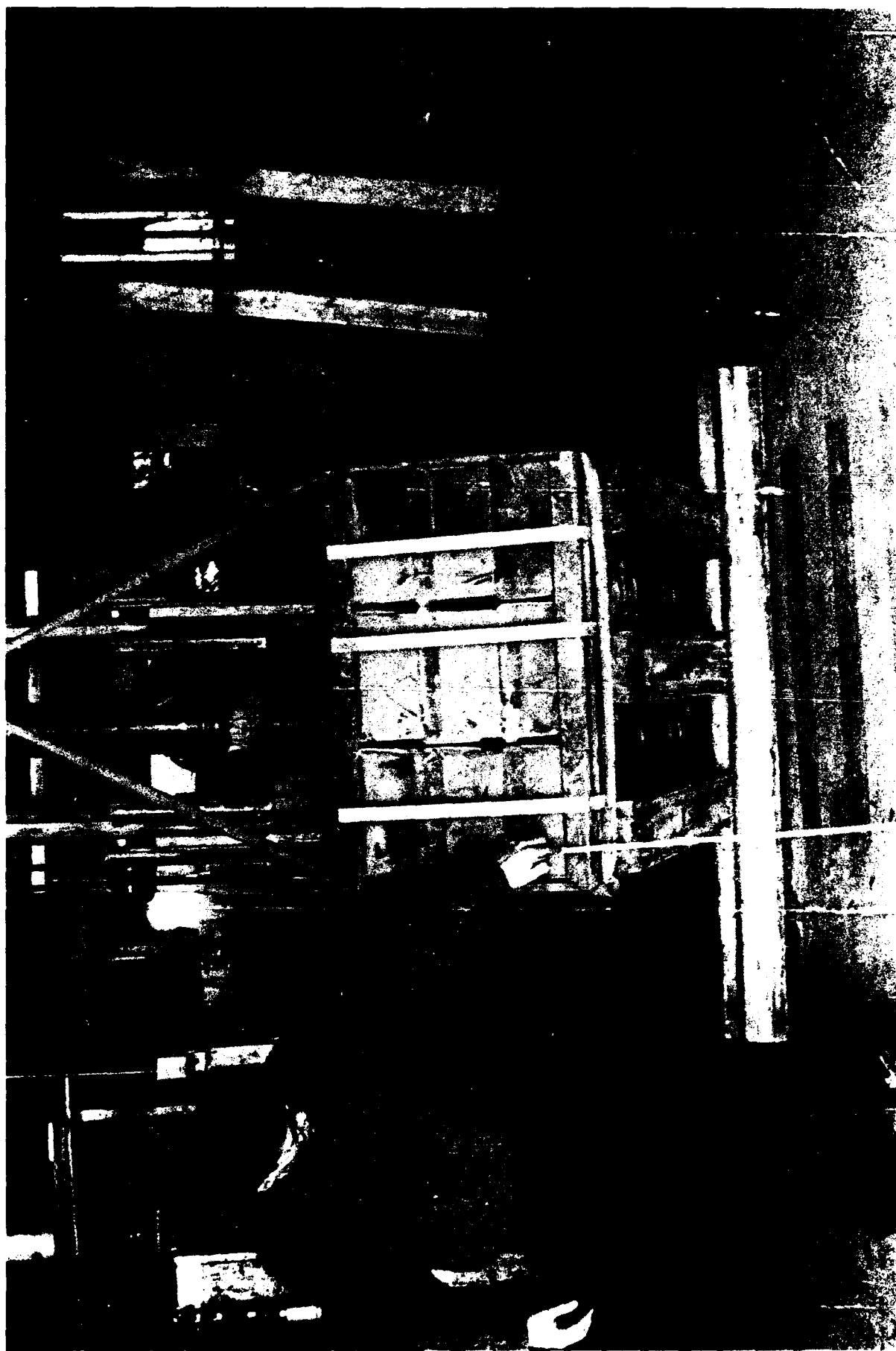

DEFENSE AMMUNITION CENTER AND SCHOOL · SAVANNA, IL

Photograph No. 5. Test pallet being raised 24 inches prior to the second edgewise rotational drop test.

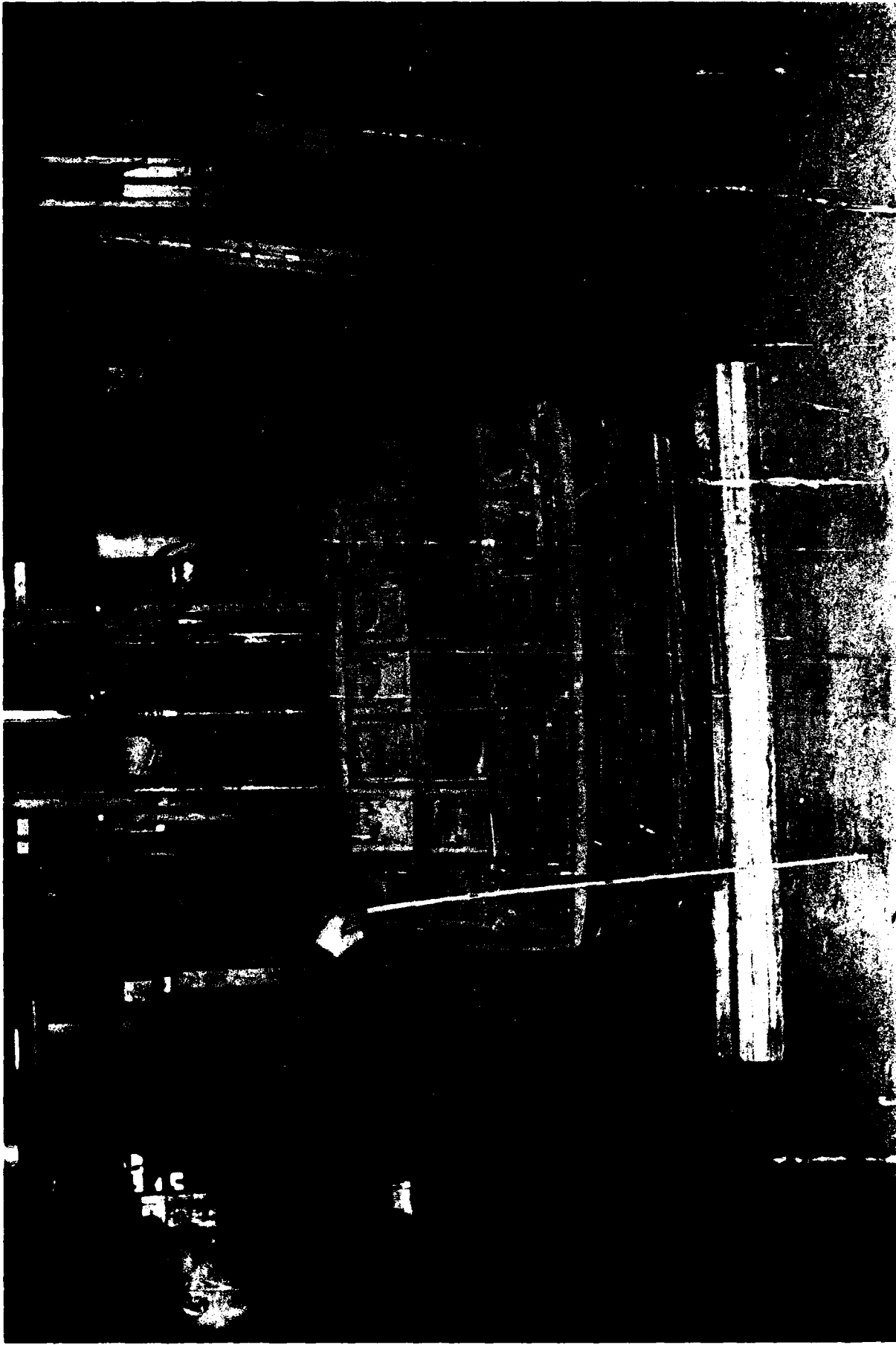

DEFENSE AMMUNITION CENTER AND SCHOOL · SAVANNA, IL

Photograph No. 6. Test pallet being raised 24 inches prior to the third edgewise rotational drop test.

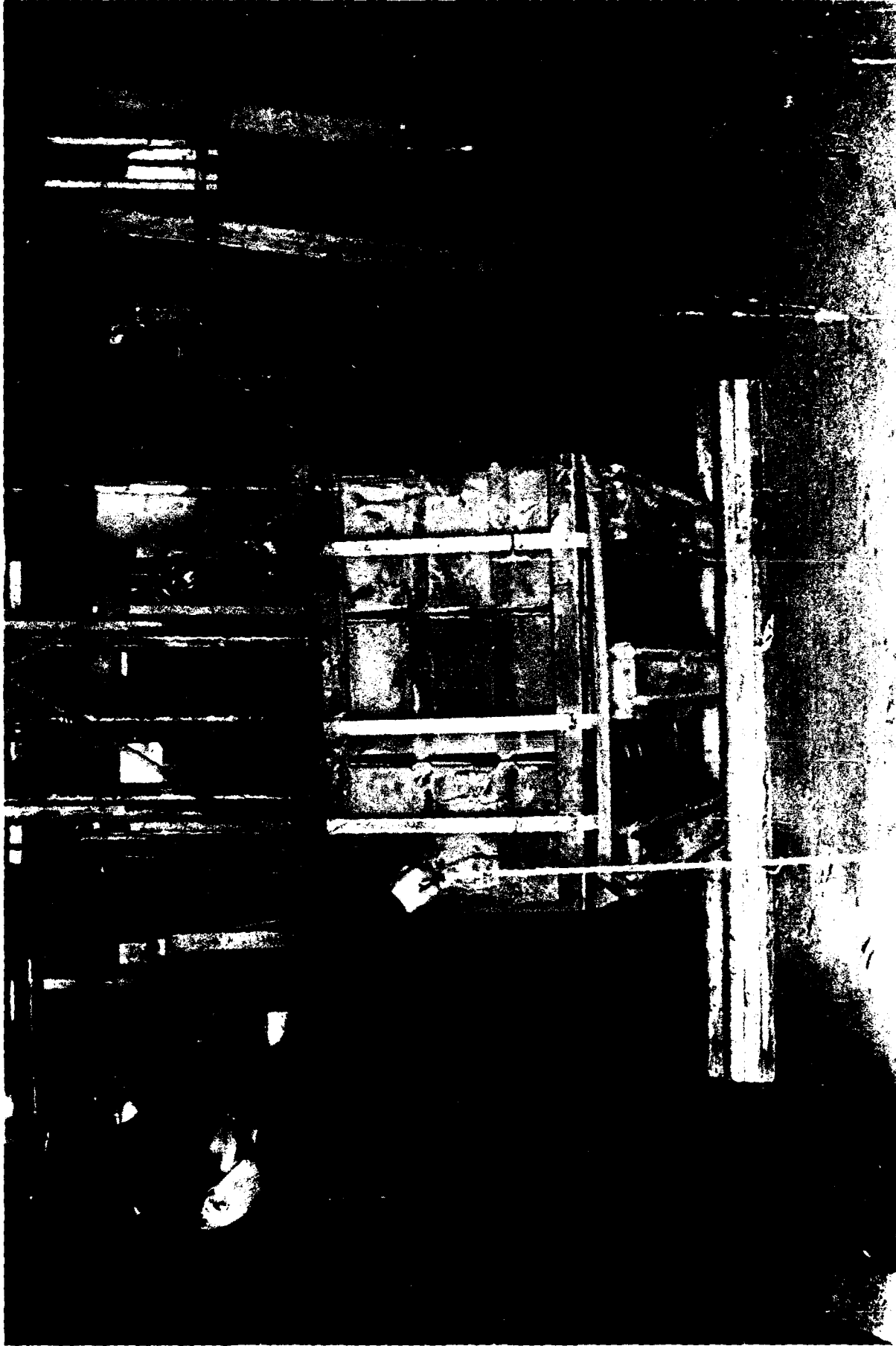

DEFENSE AMMUNITION CENTER AND SCHOOL · SAVANNA, IL

Photograph No. 7. Test pallet being raised 24 inches prior to the fourth edgewise rotational drop test.

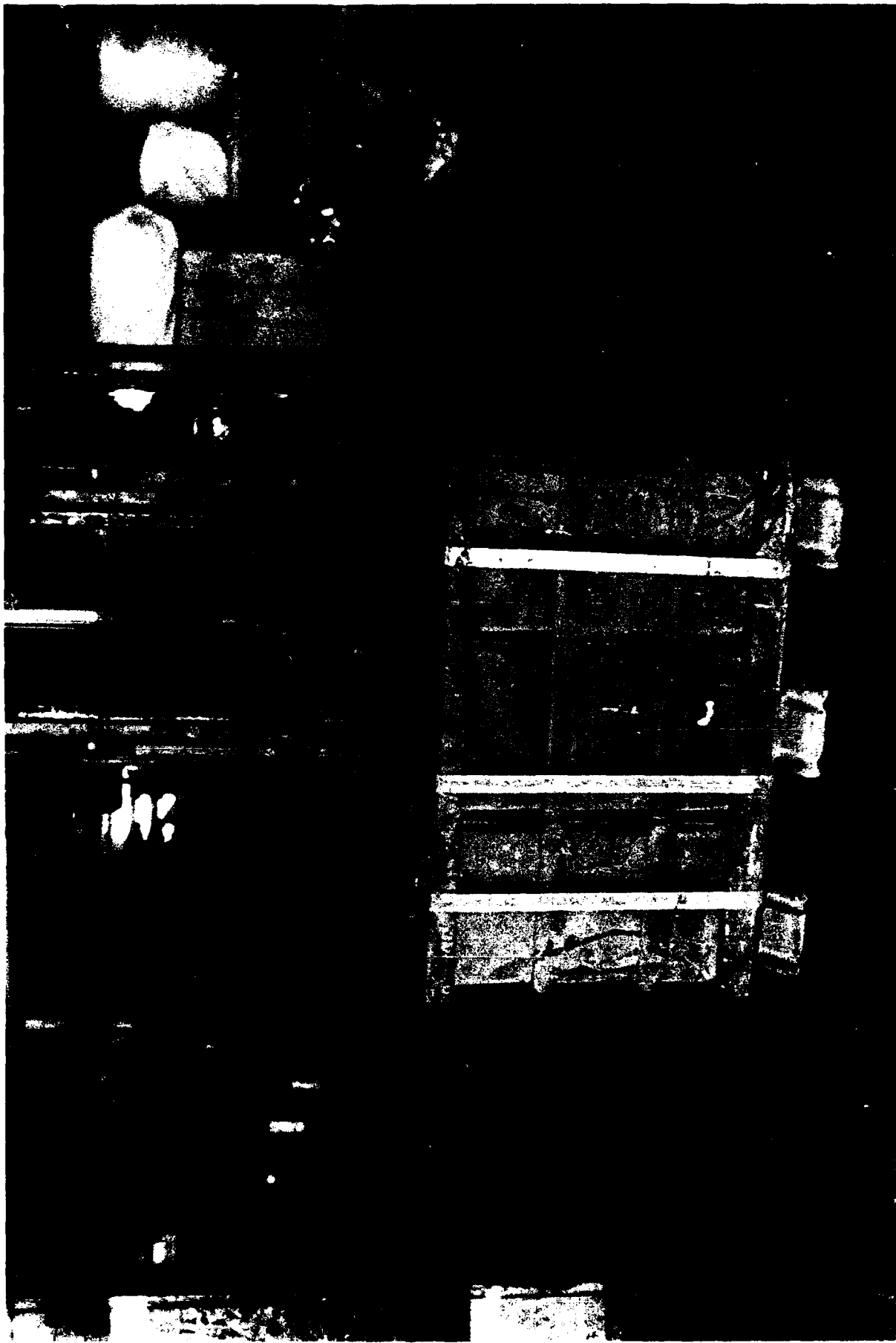

	DEFENSE AMMUNITION CENTER AND SCHOOL · SAVANNA, IL
Photograph No. 8. Test pallet being lifted by four points with a sling.	



DEFENSE AMMUNITION CENTER AND SCHOOL · SAVANNAH, IL

Photograph No. 9. Test pallet being lifted by three points with a sling.

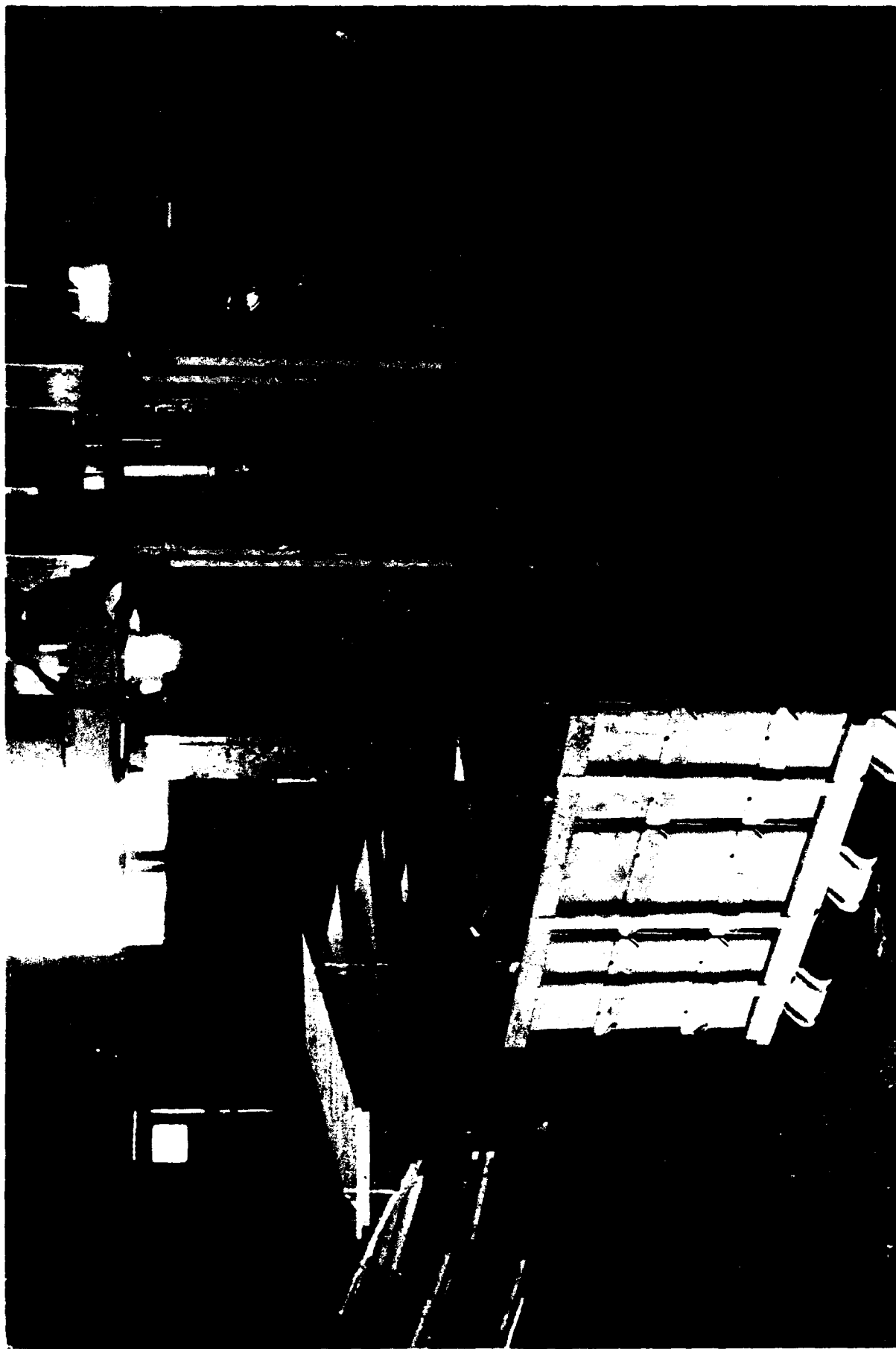

DEFENSE AMMUNITION CENTER AND SCHOOL · SAVANNA, IL

Photograph No. 10. Test pallet being lifted by two alternate points with a sling.

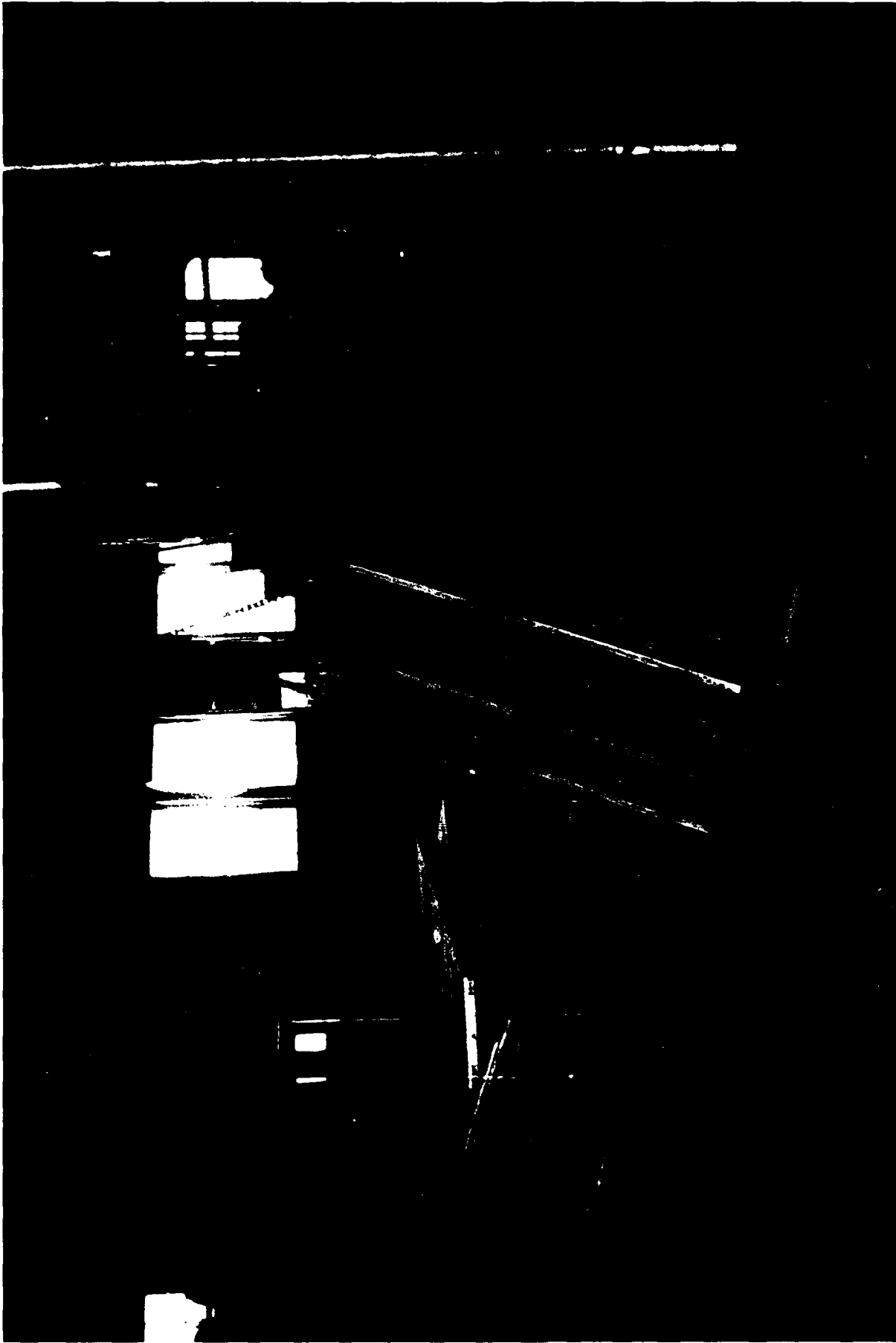

	DEFENSE AMMUNITION CENTER AND SCHOOL · SAVANNA, IL	
--	--	--

Photograph No. 11. Test pallet being lifted by two adjacent points with a sling.



DEFENSE AMMUNITION CENTER AND SCHOOL · SAVANNA, IL

Photograph No. 12 Test pallet being lifted by one point with a sling.



DEFENSE AMMUNITION CENTER AND SCHOOL SAVANNA, IL

Photograph No. 13. Test pallet prior to impact one of the inclined impact test.



	DEFENSE AMMUNITION CENTER AND SCHOOL · SAVANNA, IL	
--	--	--

Photograph No. 14. Test pallet prior to impact two of the inclined impact test.



DEFENSE AMMUNITION CENTER AND SCHOOL · SAVANNA, IL

Photograph No. 15. Test pallet prior to impact three of the inclined impact test.



DEFENSE AMMUNITION CENTER AND SCHOOL · SAYANNA, IL

Photograph No. 16. Test pallet prior to impact four of the inclined impact test.



DEFENSE AMMUNITION CENTER AND SCHOOL SAVANNA, IL

Photograph No. 17. This photograph shows one of three hinge pins that worked out during the test.



DEFENSE AMMUNITION CENTER AND SCHOOL SAVANNA, IL

Photograph No. 18. This photograph shows the large gap between the bands and the M2A2 Containers.



DEFENSE AMMUNITION CENTER AND SCHOOL · SAVANNA, IL

Photograph No. 19. This photo shows the amount of bending that occurred in the pallet base.



DEFENSE AMMUNITION CENTER AND SCHOOL SAVANNAH, IL

Photograph No. 20. This photo shows the racking of the containers that occurred when the pallet base bent.

PART 8

DRAWINGS

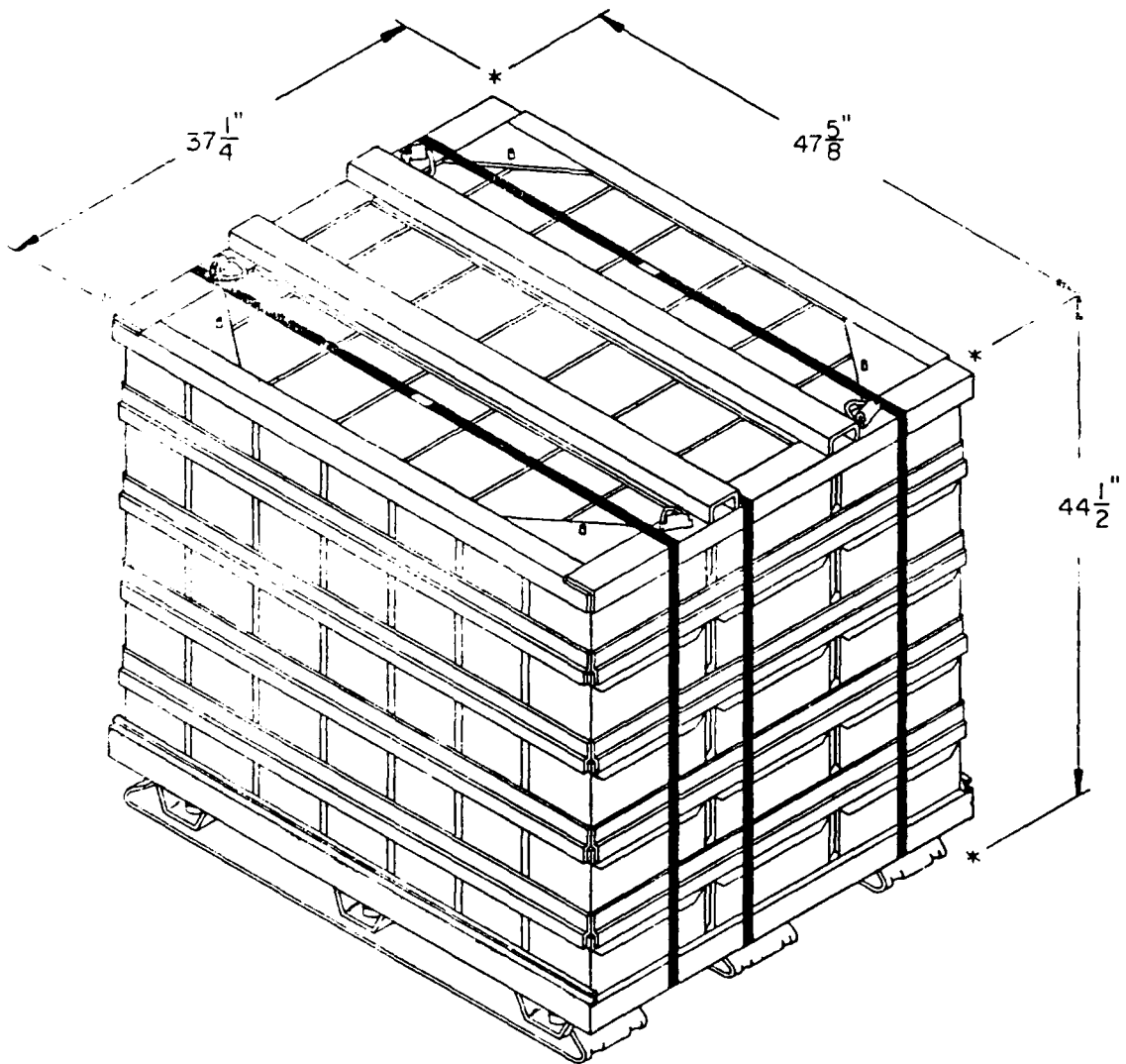

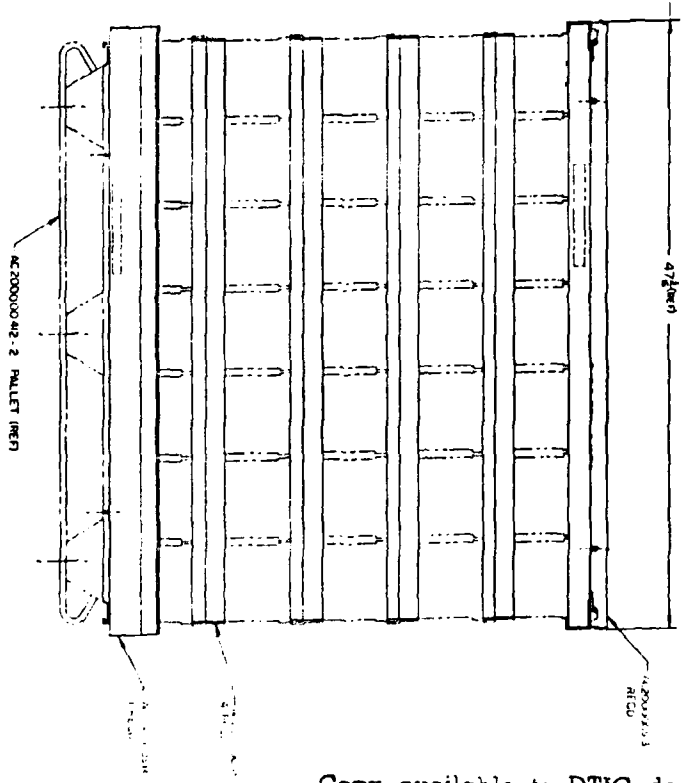
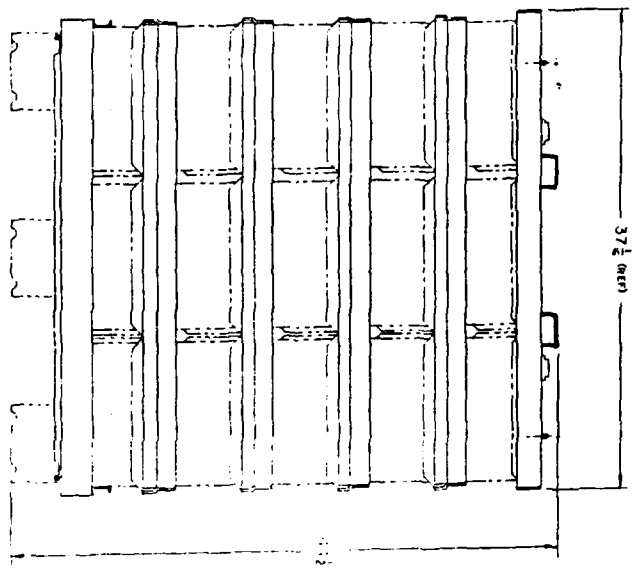

Copy available to DTIC does not permit fully legible reproduction

APPLICATION		42000003 RIBS 42000000 4x2 - 2 PALLET (REF)	
DATE: 10/1/63 BY: [Signature] TITLE: [Signature]		DATE: 10/1/63 BY: [Signature] TITLE: [Signature]	
PART NO: 42000003 QTY: 1000		PART NO: 42000000 QTY: 1000	
DRAWN BY: [Signature] CHECKED BY: [Signature]		DRAWN BY: [Signature] CHECKED BY: [Signature]	

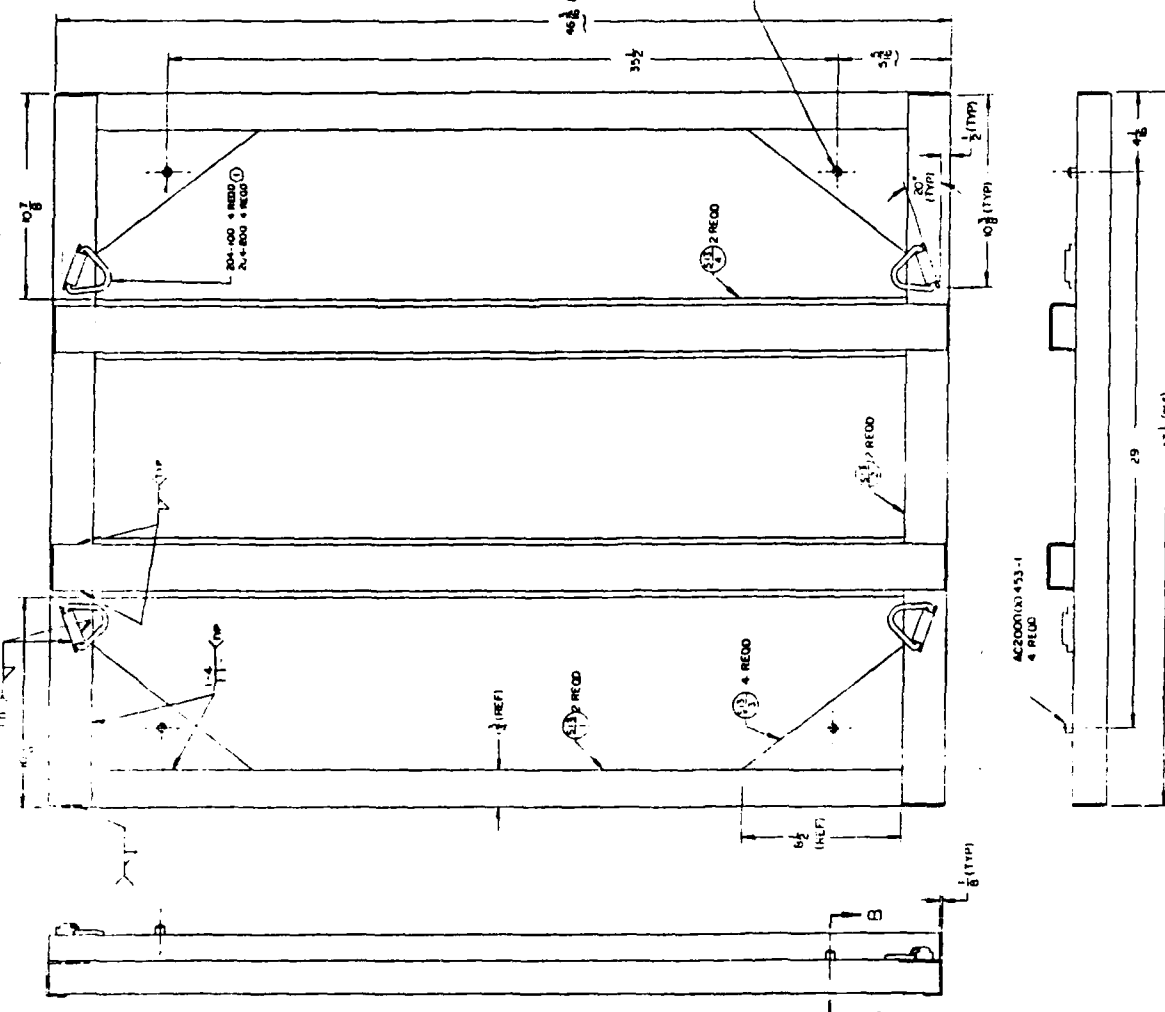

1. THIS DRAWING IS THE PROPERTY OF THE DRAWER AND IS TO BE KEPT IN CONFIDENTIALITY.

2. NO PART OF THIS DRAWING IS TO BE REPRODUCED OR TRANSMITTED IN ANY FORM OR BY ANY MEANS, ELECTRONIC OR MECHANICAL, INCLUDING PHOTOCOPYING, RECORDING, OR BY ANY INFORMATION STORAGE AND RETRIEVAL SYSTEM, WITHOUT THE WRITTEN PERMISSION OF THE DRAWER.

3. THE DRAWER ASSUMES NO LIABILITY FOR DAMAGES OF ANY KIND, INCLUDING CONSEQUENTIAL DAMAGES, ARISING FROM THE USE OF THIS DRAWING.

4. THE DRAWER ASSUMES NO LIABILITY FOR DAMAGES OF ANY KIND, INCLUDING CONSEQUENTIAL DAMAGES, ARISING FROM THE USE OF THIS DRAWING.

5. THE DRAWER ASSUMES NO LIABILITY FOR DAMAGES OF ANY KIND, INCLUDING CONSEQUENTIAL DAMAGES, ARISING FROM THE USE OF THIS DRAWING.

6. THE DRAWER ASSUMES NO LIABILITY FOR DAMAGES OF ANY KIND, INCLUDING CONSEQUENTIAL DAMAGES, ARISING FROM THE USE OF THIS DRAWING.

Copy of this drawing DTIC does not

8 - 4

REVISION	DATE	BY	APP'D

PROJECT NO.	28620
REV.	F
DATE	
BY	
APP'D	

TOP FRAME ASSY
1/2" SCALE

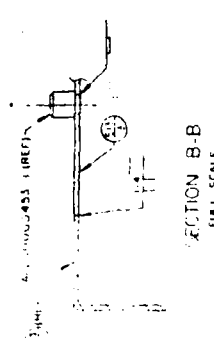

SECTION B-B
FULL SCALE

1. TITLE BLOCK
 2. GENERAL NOTES
 3. DIMENSIONS
 4. PARTS LIST
 5. ASSEMBLY DRAWING
 6. CONSTRUCTION DETAILS
 7. FINISHES
 8. MATERIALS

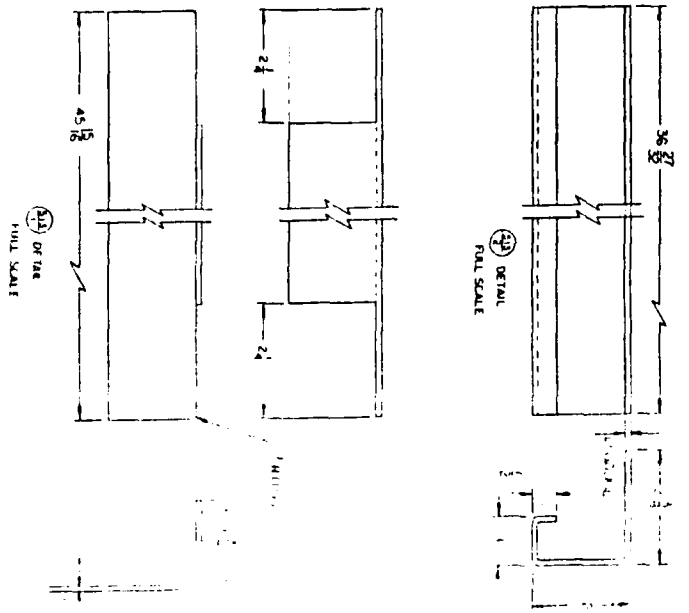
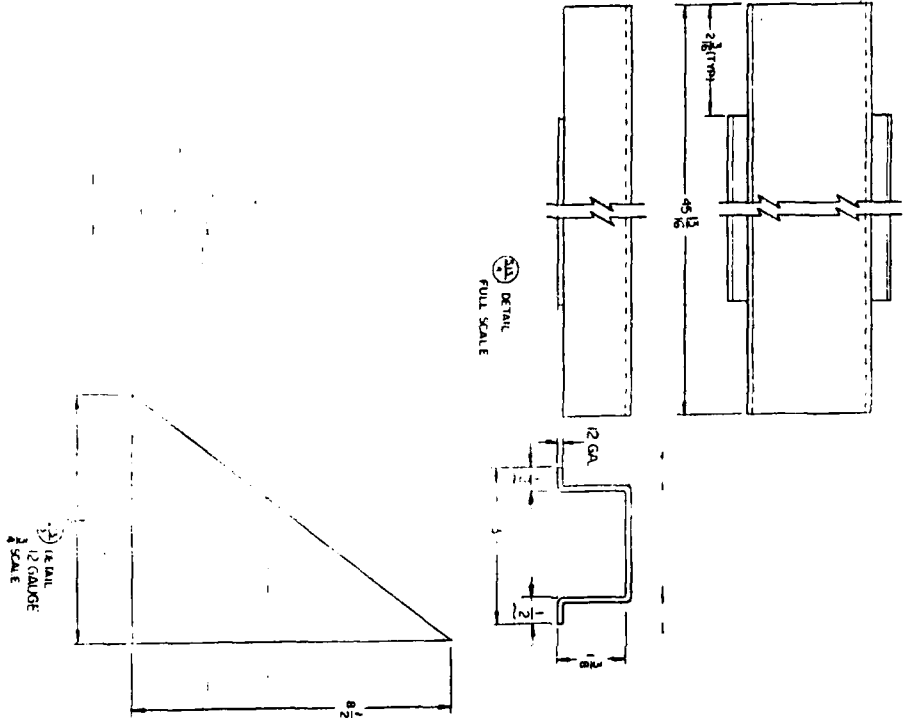

APPLICATION	REVISIONS	DATE	BY	CHKD BY	DESIGNED BY	APPROVED BY

Copy available to DTIC does not
 permit fully legible reproduction.

Copy available to DTIC does not permit fully legible reproduction

8 - 7

ALL INFORMATION CONTAINED
HEREIN IS UNCLASSIFIED
DATE 10-13-2010 BY 60322
UCBAW/SJS/STP/STP

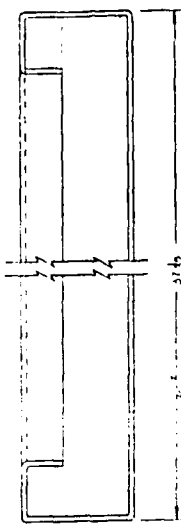
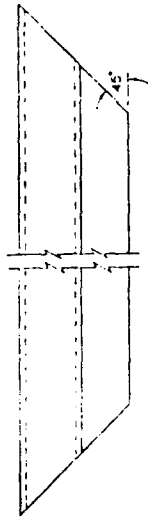

(10) DETAIL FULL SCALE

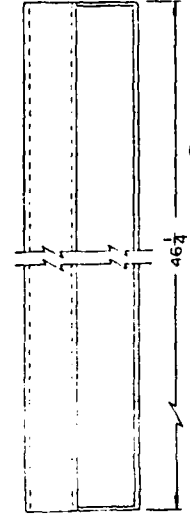
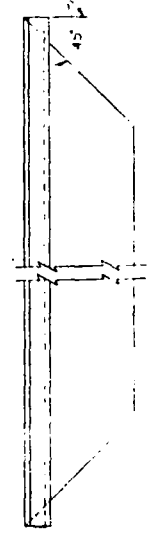

(11) DETAIL FULL SCALE

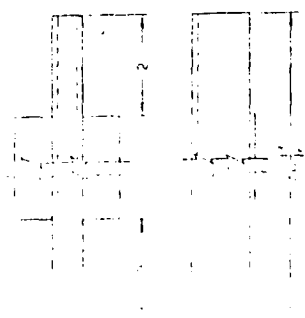

(12) DETAIL FULL SCALE

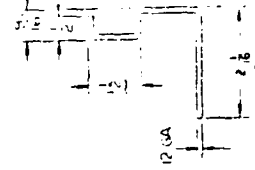
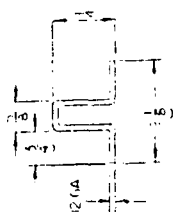

PROJECT NO. 28870 DRAWING NO. 28870-1 SHEET NO. 1 OF 1		DATE 10/13/10 BY 60322 CHECKED BY STP/STP	DESIGNED BY DRAWN BY IN CHARGE BY	APPROVED BY <i>Stanford</i>
TITLE PARTS LIST MATERIALS LIST DIMENSIONS LIST NOTES				
APPLICATION				

Copy available to DTIC does not
 contain fully legible reproduction

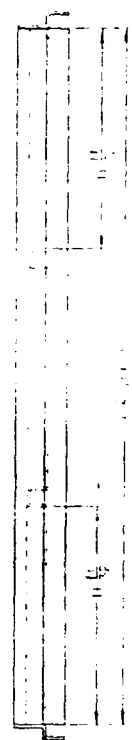
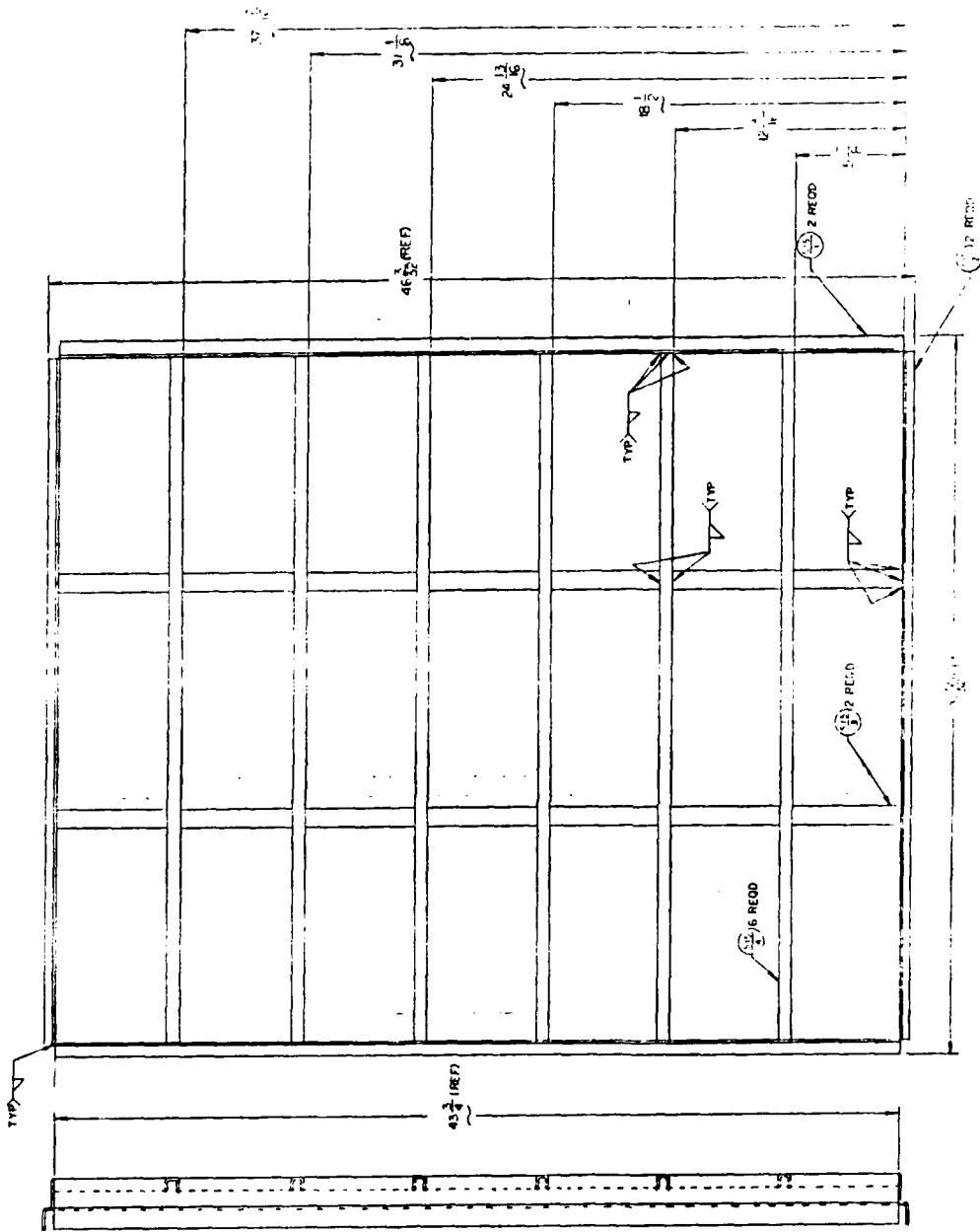

NO.	DESCRIPTION	QTY	UNIT
1	FRONT PANEL	1	PCB
2	BACK PANEL	1	PCB
3	FRONT PANEL	1	PCB
4	BACK PANEL	1	PCB
5	FRONT PANEL	1	PCB
6	BACK PANEL	1	PCB
7	FRONT PANEL	1	PCB
8	BACK PANEL	1	PCB
9	FRONT PANEL	1	PCB
10	BACK PANEL	1	PCB

INTERMEDIATE FROM 3-51
 1/2" SCALE

DIMENSIONS			
A	B	C	D
2 1/2	1 1/2	2	4 1/2
2 1/2	1 1/2	1	4 1/2

1. MATERIALS TO BE USED ARE LISTED IN THIS DRAWING.
2. DIMENSIONS ARE GIVEN IN INCHES UNLESS OTHERWISE SPECIFIED.
3. ALL DIMENSIONS ARE TO BE TAKEN TO THE CENTER OF THE DIMENSIONED AREA UNLESS OTHERWISE SPECIFIED.
4. DIMENSIONS ARE TO BE TAKEN TO THE CENTER OF THE DIMENSIONED AREA UNLESS OTHERWISE SPECIFIED.
5. DIMENSIONS ARE TO BE TAKEN TO THE CENTER OF THE DIMENSIONED AREA UNLESS OTHERWISE SPECIFIED.
6. DIMENSIONS ARE TO BE TAKEN TO THE CENTER OF THE DIMENSIONED AREA UNLESS OTHERWISE SPECIFIED.
7. DIMENSIONS ARE TO BE TAKEN TO THE CENTER OF THE DIMENSIONED AREA UNLESS OTHERWISE SPECIFIED.
8. DIMENSIONS ARE TO BE TAKEN TO THE CENTER OF THE DIMENSIONED AREA UNLESS OTHERWISE SPECIFIED.
9. DIMENSIONS ARE TO BE TAKEN TO THE CENTER OF THE DIMENSIONED AREA UNLESS OTHERWISE SPECIFIED.
10. DIMENSIONS ARE TO BE TAKEN TO THE CENTER OF THE DIMENSIONED AREA UNLESS OTHERWISE SPECIFIED.

DIMENSIONS		
A	B	C
2 1/2	1 1/2	4 1/2
2 1/2	1 1/2	4 1/2

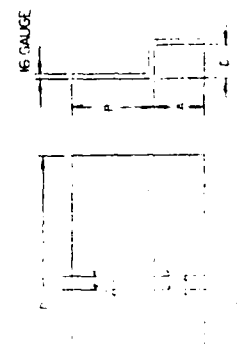
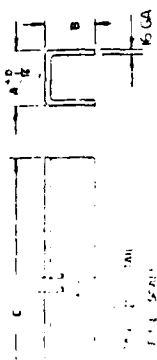

1/8" CA