

DTIC FILE COPY

②

STRATEGIC STUDIES INSTITUTE
U.S. ARMY WAR COLLEGE
CARLISLE BARRACKS, PENNSYLVANIA 17013-5050

20 JANUARY 1988

ACN 88001

AD-A201 065

ALTERNATIVE WORLD SCENARIOS
FOR STRATEGIC PLANNING



Futures Report

DTIC
ELECTE
NOV 29 1988
S D
E

DISTRIBUTION STATEMENT:
Approved for public release;
distribution unlimited.

The views, opinions, and/or findings
contained in this report are those of
the author and should not be construed
as an official Department of the Army
position, policy, or decision, unless
so designated by other official
documentation.

38 11 29 009

U.S. ARMY WAR COLLEGE

Major General Howard D. Graves

* * * * *

STRATEGIC STUDIES INSTITUTE

Director
Colonel Thomas R. Stone

Author
Charles W. Taylor

Editor
Marianne P. Cowling

Secretary
Shirley A. Shearer

* * * * *

STRATEGIC STUDIES INSTITUTE
U.S. ARMY WAR COLLEGE
Carlisle Barracks, Pennsylvania 17013-5050

20 January 1988

ACN 88001



ALTERNATIVE WORLD SCENARIOS
FOR STRATEGIC PLANNING

by

Charles W. Taylor

FUTURES REPORT

Accession For	
NTIS GRA&I	<input checked="" type="checkbox"/>
DTIC TAB	<input type="checkbox"/>
Unannounced	<input type="checkbox"/>
Justification	
By _____	
Distribution/	
Availability Codes	
Dist	Avail and/or Special
A-1	

DISTRIBUTION STATEMENT:
Approved for public release;
distribution unlimited.

The views, opinions, and/or findings contained in this report are those of the author and should not be construed as an official Department of the Army position, policy, or decision, unless so designated by other official documentation.

DISCLAIMER

The contents of this report represent the research and reasoning of the author and should not be construed as an official Department of the Army position, policy or decision, unless so designated by other official documents.

FOREWORD

This Futures Report presents a set of four interrelated alternative world environments (scenarios) for the year 2020 that are suitable for strategic planning throughout the Department of the Army. Additionally, the author describes a method to construct these scenarios in a framework called "the cone of plausibility."

The scenarios are projected to and described for the years 2005 and 2020. They present possible end states in the world and domestic political, economic, technological, and social environments. The projected notions of the scenarios challenge widely held assumptions about the future structure of the Army.

The four scenarios were examined and evaluated by selected Harvard University scholars of the John F. Kennedy School of Government. They concluded that the basic methodology is sound, the outlines of the scenarios are plausible, and their utility can be extended to other areas of long-range military planning.

This report, written by Charles W. Taylor, is published by the Strategic Studies Institute, U.S. Army War College, as a contribution to long-range planning and the future of the Army.



HOWARD D. GRAVES
Major General, USA
Commandant

TABLE OF CONTENTS

	<u>Page</u>
FOREWORD	iii
EXECUTIVE SUMMARY	ix
CHAPTER 1. THE PROCESS	1
Introduction	1
Methods	1
The Cone of Plausibility	2
Plausible Scenarios	2
Wild Card Scenarios	4
Scenario Drivers	4
Report Organization	5
Endnotes	7
CHAPTER 2. THE EARLY DECADES OF THE 21ST CENTURY	11
A Common Background	11
The Assumptions	11
The Trends	11
Summary	17
Endnotes	19
CHAPTER 3. SCENARIO SYNOPSES AND ATTRIBUTES	21
Development of the Scenarios	21
Finalizing the Scenarios	21
Synopsis of the Scenarios in 2020	22
Attributes of the Scenarios in 2020	25
Endnotes	27
CHAPTER 4. ALTERNATIVE WORLD SCENARIOS: THE ALPHA SCENARIOS	29
Section I. ALPHA 2005	29
Section II. ALPHA 2020	33
CHAPTER 5. ALTERNATIVE WORLD SCENARIOS: THE BRAVO SCENARIOS	37
Section I. BRAVO 2005	37
Section II. BRAVO 2020	41
CHAPTER 6. ALTERNATIVE WORLD SCENARIOS: THE CHARLIE SCENARIOS	45
Section I. CHARLIE 2005	45
Section II. CHARLIE 2020	49

CHAPTER 7. ALTERNATIVE WORLD SCENARIOS: THE DELTA SCENARIOS	53
Section I. DELTA 2005	53
Section II. DELTA 2020	57
SELECTED BIBLIOGRAPHY	61
APPENDIX A. EXPANDED THEMES OF ALPHA 2020: U.S. ISOLATIONIST	A-1
APPENDIX B. EXPANDED THEMES OF BRAVO 2020: U.S. WORLD PEACEKEEPER . .	B-1
APPENDIX C. EXPANDED THEMES OF CHARLIE 2020: NEONATIONALISM WORLD . .	C-1
APPENDIX D. EXPANDED THEMES OF DELTA 2020: MUTED BIPOLAR WORLD . . .	D-1
APPENDIX E. DISTRIBUTION	E-1

DD FORM 1473

TABLES

	<u>Page</u>
1. Scenario Drivers for Alternative World Scenarios for Strategic Planning	6
2. An Arrangement of Nations by Industrialization and Modernization	13
3. Some Comparative and Descriptive Characteristics of the Categories of Nations Projected to 2020	14
4. Projected Population Estimates, 2000, 2005 and 2020 (in millions) .	15
5. Estimate of Nations Possessing Nuclear Power Plants in 2020	16
6. Hypothetical Estimates of Nations Possessing Nuclear Weapons and Delivery Means in the Year 2020	18
7. The Scenario Drivers Arranged in Order of Theme Dominance	23
8. Comparison of Scenario Attributes for 2020	26

FIGURE

1. The Cone of Plausibility	3
---------------------------------------	---

BIOGRAPHICAL SKETCH OF THE AUTHOR

CHARLES W. TAYLOR, a faculty member of the U.S. Army War College, is a strategic futurist with the Strategic Studies Institute (SSI). His futures research extends over 20 years and includes major contributions in the form of narrative long-range forecasts as well as in methods and designs of forecasts for studies requested by the Deputy Chief of Staff for Operations and Plans, Department of the Army. He is the author of a number of futures reports including "The Technical Report to Forecast 90"; "A Concept of a Future Force"; "The Relationship of Forecasting to Long-Range Planning"; the "Pilot Delphi Project," a forecast of strategic issues to the year 2030; and "A World 2010: A Decline of Superpower Influence." Mr. Taylor is the originator of the "Panel Consensus Technique," a widely recognized contribution to participative decisionmaking, problem solving and forecasting. He is a member of the International Studies Association, American Academy of Political and Social Sciences, World Future Society, Population Reference Bureau, New York Academy of Science, and Military Operations Research Society.

EXECUTIVE SUMMARY

Introduction.

This Futures Report offers Department of the Army (DA) and Department of Defense (DOD) planners, decisionmakers, and policymakers useful ways to describe and examine alternative futures. The report provides methods to project trends or events into the long-range future while retaining their plausibility. Additionally, it presents possible alternative conditions, trends and events that are likely to influence and challenge future defense postures. Finally, the report introduces a plausible framework for considering common future world environments in midrange and long-range planning.

Origin.

This report originates from a U.S. Army Chief of Staff Memorandum (CSM 86-15-14, 6 November 1986, "Long Range Stationing Plan for the Army"), which directed the U.S. Army War College, Strategic Studies Institute (SSI) to assist the Long Range Stationing Study (LRSS) Group by developing plausible alternative world environments in which the Army may operate in the year 2020. This report includes the descriptions of four alternative future world scenarios (environments) that the LRSS Group used to develop a comprehensive long-range stationing process suitable for detailed Army planning at any point along a time line to 2020.

Scenarios, What Are They?

Scenarios are descriptions of a possible set of circumstances and conditions that may exist in the present or future. Scenarios concerning the future describe possible, although not certain, projections or evolutions of trends, events, and conditions from today to a future time period. Scenarios must be plausible from today to the planning focus year(s) for realistic and valid planning. They may be used as forecasts but other forecasting methods using experts (e.g., Delphi, cross-impact analysis) are superior. Scenarios are best used in sets of three or more to assure a broad outlook of the future. Scenarios are used in a set of four in this report and are neither intended to be forecasts (probabilistic projections) nor to be predictions (deterministic projections).

Validation.

Since the SSI scenarios were important to the development of LRSS process, the LRSS Study Advisory Group (SAG), under the chairmanship of the Deputy Chief of Staff for Operations and Plans, requested an outside view on their validity. The plausibility of the scenarios, the methods used to develop them, as well as the methods created by the LRSS Group were validated by a seminar conducted by scholars of the J. F. Kennedy School of Government at Harvard University. The Seminar Leader, Mr. Robert J. Murray, stated that "this methodology appears, however, to have even wider decision-making utility for the Army and, perhaps, for the Department of Defense as a whole." Mr. Murray's entire remarks are in the "Statement by the Seminar Leader" as Addendum A to this summary.

Objectives.

The objectives of this report are twofold:

- o to establish a method for DA agencies and DOD to plan from the midrange to the long-range future through the use of a common alternative world scenarios approach and
- o to describe a set of four future alternative world scenarios that are plausible, realistic, and appropriate for national defense planning throughout most areas of defense interests.

Methods.

The scenarios were prepared incrementally through:

- o especially designed workshops that permitted a close interchange of ideas, direction, and visions of Army planning goals and responses between the planners (representatives from the Army Staff, the MACOMs, and the Reserve components) and the futurist (the author);
- o impromptu guidance by the futurist to the planners during the workshops as to how to project plausible ideas and trends 10 to 20 years out by cause and effect relationships.

The Cone of Plausibility.

From this cooperative and iterative process were derived scenarios containing plausible consequences of trends, events, and conditions of the late 20th century projected and tracked from 1990 to the planning focus years 2005 and 2020 and back again to 1990. The set of four alternative world scenarios, then, is a combination of world environments that are plausible as well as germane to Army planning and its architecture, now and in the long-range future. The process for the development of the scenarios provides a context for DA decisionmaking, policymaking, and planning for the mid (2-10 years) and long (10-20 years) terms.

In this context, the transition of the scenarios through the passage of time from the 20th century into the 21st century is in the form of a theoretical cone. Within the cone, cause and effect relationships that define the Army's existence in response to the external world characteristics represent trends that can be tracked from today to any point along a time line into the future. Although use of the cone does not increase the accuracy of the forecast of the scenarios, tracking establishes and reinforces the validity and plausibility of the scenarios. The real future, more than likely, falls somewhere among the alternative environments of the cone. The cone is called "the cone of plausibility" and is displayed on the following page.

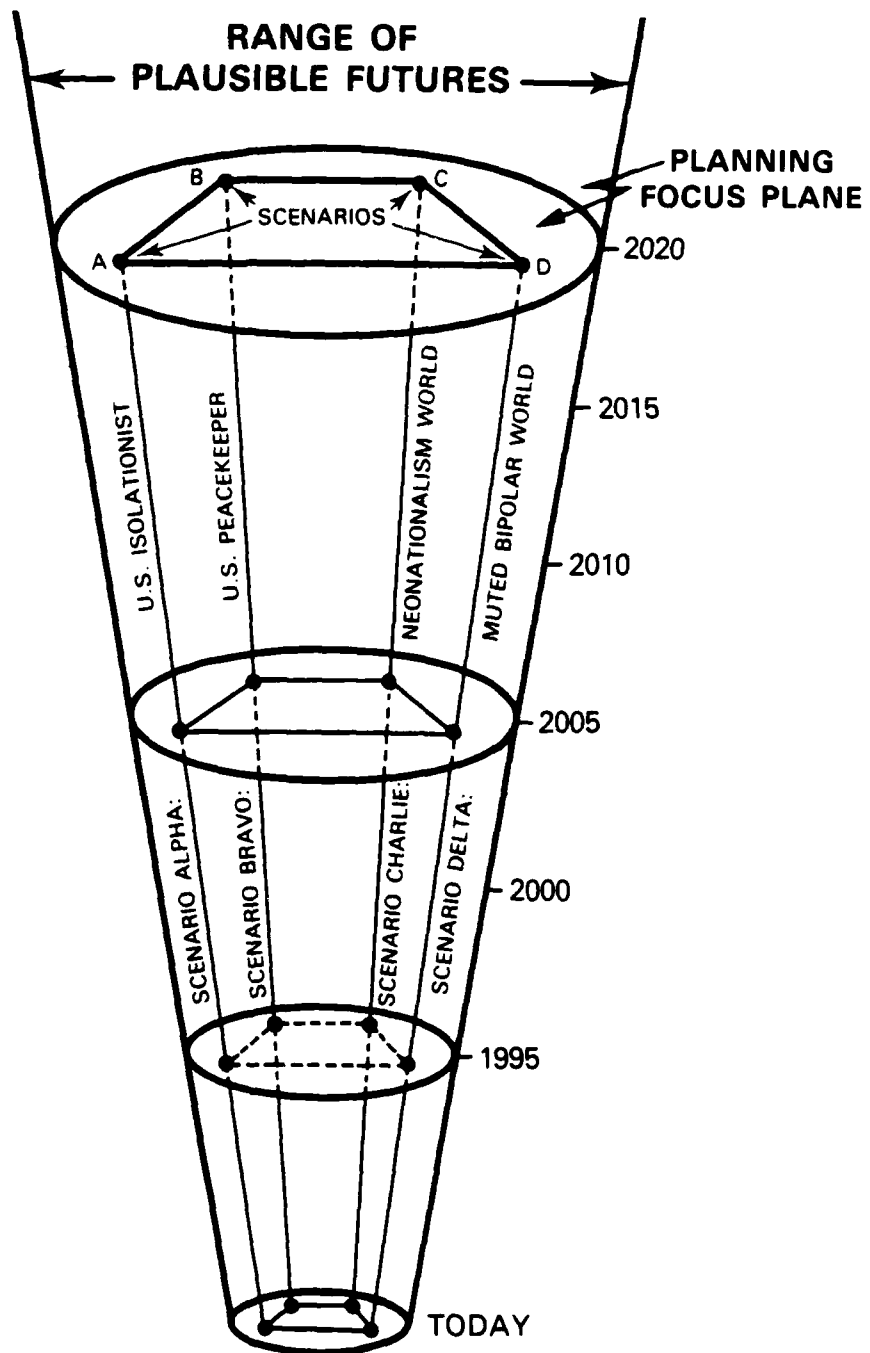

THE CONE OF PLAUSIBILITY

Scenarios projected within the cone are considered plausible if they adhere to a logical progression of each scenario's trends, events, and consequences from today to the planning focus planes of 2005 and 2020, ergo, allowing longitudinal as well as cross-sectional analyses. This assures a high degree of plausibility and compatibility between the present and the future. Thus, the trends and events and their likely outcomes are intermeshed with and provide guidance for the Army Long-Range Planning Guidance (ALRPG); The Army Plan (TAP), its direction and orientation; and the Program Objective Memorandum (POM) with its Extended Planning Annex (EPA).

Advantages to Users.

The following are advantages of using alternative scenarios:

- o they present realistic external environments that challenge users to decide what must be done today to achieve long-term objectives;
- o they allow planners and decisionmakers to explore alternative objectives since they are not so threat driven that the users cannot examine and plan for the peacetime management of change;
- o they provide a context for planning where a spectrum of trends and concepts can be considered across a variety of settings where economic, political, technological, and sociological trends and conditions can alternately be the dominant environmental driver;
- o they allow users to freely develop more effective and impartial responses;
- o they provide a commonality for a variety of discussions and comparisons among the scenario users, such as DA or DOD, when each scenario is given a descriptive title, shared reference and common vocabulary; and,
- o they offer the Department of the Army a method by which it can plan realistically for different operating climates, restraints, requirements, and resources for the future.

Synopses of the four scenarios in 2020 are in Addendum B to this summary. Notional Army responses that were developed by the long-range planners and the LRSS Group are included with these scenario synopses in order to illustrate the usefulness of the method and scenarios. The four scenarios have the following identification and descriptive titles:

- o Scenario ALPHA: U.S. Isolationist;
- o Scenario BRAVO: U.S. World Peacekeeper;
- o Scenario CHARLIE: Neonationalism World; and
- o Scenario DELTA: Muted Bipolar World.

ADDENDUM A

Statement by Seminar Leader

The briefing of the Long Range Stationing Study plan of action by the Army's Projector Director, our review of the scenarios on future world conditions created by the Army War College, and the discussion during the Harvard seminar, lead me to conclude that the methodology adopted by the Army for this project will, in fact, prove useful in decision-making on future Army stationing plans.

The methodology appears, however, to have even wider decision-making utility for the Army and, perhaps, for the Department of Defense as a whole. The methodology seems potentially useful, in particular, in the Planning, Programming, Budgeting System (PPBS). The Planning phase of the PPBS has never been as useful to decision-makers as it needs to be. It lacks the rigor, and often the priorities, needed to usefully impact the Program decisions. We need a more insightful planning phase to help shape decisions on force structure, procurement, and resource allocation.

This methodology, by examining and discussing alternative futures, can help planners do a better job of describing for decision-makers the implications for our defense posture of alternative world situations. It could help provide a better context for the Extended Planning Annex and for the Program Objective Memorandum. This methodology appears sufficiently promising for these larger purposes as to be worth exploring in detail.

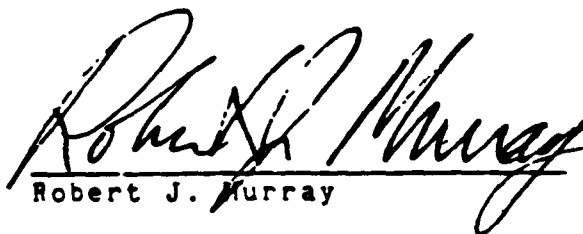

Robert J. Murray

ADDENDUM B

SYNOPSIS OF THE 2020 SCENARIOS*

SCENARIO ALPHA: U.S. ISOLATIONIST

This scenario describes a relatively peaceful world in 2020 where the U.S. perception of an external threat is low. In this international environment the United States has turned somewhat toward isolationism. In general, the concerns of the U.S. leadership are directed more toward greater budgetary investments in social and welfare programs than in programs for defense or for foreign economic and military aid. For the most part, U.S. and other Western postindustrial infrastructures lack the capacity to support a major industrial mobilization comparable to the surge capability of mid-20th century. A rise of nationalism throughout nations of the world including nations with prior long-term agreements with the United States has suppressed U.S. international influence as well as precluded U.S. military presence overseas. Increasingly, U.S. community infrastructures (economies, politics, demographics, resources, and others) are inhibiting the capabilities for the military to meet stationing requirements, to conduct installation activities, and acquire new investments. The Army budget has dropped significantly to about \$55 billion. Army combat forces are 15 percent heavy, 50 percent medium, and 35 percent light. Only about half of the Army forces are equipped with high-tech, i.e., state-of-the-art, equipment. The Active Army strength hovers at 350 thousand and the Reserve forces at 750 thousand.

SCENARIO BRAVO: U.S. WORLD PEACEKEEPER

This scenario describes a competitive world of economic trade in 2020 where external threats, both economic and military, to U.S. and allied interests are perceptibly increasing. Worldwide U.S. economic and military assistance agreements are backed by a large U.S. peacekeeping military force. A tradeoff of nationalism for economic development by many nations worldwide has preserved U.S. military presence overseas and strengthened the international influence of the United States. Despite deindustrialization since the latter half of the past century, western postindustrial infrastructures can support industrial mobilization, and even surge. U.S. leadership in the Congress and Administration advocate a strong military defense. The Army budget alone has increased to \$105 billion. Army combat forces are 40 percent heavy, 10 percent light, and 50 percent medium. In general the total force is about 60 percent high-tech. The Active Army strength is about 850 thousand troops with a Reserve component of 1.7 million troops. The Soviet Union has also increased its military forces and is a larger threat to world peace now than it was in 1990. This threat has forced the United States to enact a universal public service program which includes the military services and provides a constant source of trained troops.

SCENARIO CHARLIE: NEONATIONALISM

The rise of nationalism worldwide in 2020 has significantly suppressed U.S. political, economic, and military influence and has eliminated the presence of the U.S. military overseas. It is a highly competitive world where economic trade wars and restrictions abound. External threats to U.S. interests are more of a challenge to U.S. economic trade than to political ideology. The U.S. leadership has provided substantial budgetary support to social and welfare programs. This has constrained U.S. security to a small, high-tech military force and reduced the Army budget to about \$120 billion. Although U.S. community infrastructures tend to inhibit the capabilities for the military to meet stationing requirements and to reduce installation investments, the general public image toward military service is high. Despite U.S. national political leaders advocating a strong military defense, military end strength is low. The Active Army consists of 225 thousand troops and the Reserves are at 1.3 million. The Army's combat forces are 10 percent heavy, 40 percent light, and 50 percent medium. They are 100 percent high-tech in weapons and other equipment.

SCENARIO DELTA: MUTED BIPOLAR WORLD

This scenario describes a productive economic world in 2020 where U.S. political leadership favors social and welfare investments over those of defense and where U.S. communities increasingly object to military activities at nearby bases. The external threat to U.S. and allied interests is generally perceived to be about the same as it was in the early 1990s, although the Soviet threat is slightly less. U.S. international influence has been strengthened by most nations worldwide making a tradeoff of nationalism for economic growth. With reduction of Army presence overseas, its budget is at \$85 billion. Congress is considering combining the Army, Navy, and Air Force into one service. The Army combat forces in this scenario are 60 percent heavy, 20 percent medium, and 20 percent light. The Army is about 75 percent high-tech with an Active component strength of 750 thousand troops and a Reserve of 1.2 million.

* Heavy, medium, and light in these scenarios refer to the relative difficulty to transport or project rapidly to worldwide locations. Also a "light" 2020 unit has equal or greater lethality than a "heavy" 1990 unit. Finally, the numbers used in this report for Army responses, here and elsewhere, are notional and have not been validated by the LRSS decision process.

CHAPTER 1

THE PROCESS

Introduction.

This Futures Report has two objectives: (1) to establish a method for Department of the Army (DA) agencies to plan for the midrange to the long-range future through the use of an alternative scenario approach and (2) to describe four future alternative world scenarios (environments) that are plausible, realistic, and appropriate for Army planning.

The scenarios in this report have broad utility throughout the Army and potential use throughout the Department of Defense (DOD). Their credibility was established by a general officer Study Advisory Group during the course of their use in the "Long Range Stationing Study (LRSS) for the Army in 2020"¹ for which they were originally designed. The alternative scenario design used for the project and described in this report provides a set of four relevant, interrelated scenarios for midrange to long-range planning as well as for policymaking and decisionmaking. Each scenario of the set is multifaceted, holistic, and internally consistent with a time and topic of interest focus, yet interrelated by design with the other scenarios of the set.

The scenarios address two time periods for military planning: the years 2005 and 2020. These periods provide an historical perspective linking 20th century experiences to 21st century requirements, allowing planners to posture for an evolutionary transition of military forces into the 21st century. Further, the scenarios highlight key underlying conditions that may set in motion changes in national defense during peacetime. As such, they provide a background for planning alternative strategic courses of action and assessing defense policies as well as provide a framework for exploring long-term defense requirements. Moreover, the alternative scenarios include common parameters that make the most difference to an organization and against which most of its elements can plan or make decisions and policies.

The advantage of the alternative scenario approach is that it provides a context for planning where a spectrum of trends and concepts can be considered across a variety of settings.² Giving each scenario a descriptive title provides a shared reference and common vocabulary for a variety of discussions and comparisons among the scenario users,³ such as DA or DOD.

Methods.

Scenarios are narratives or outlines that depict preselected environments at some near or far off time. They usually consist of knowable things, conditions, and situations in new relationships that when projected into the future evoke new concepts and ideas about change. Although they are neither predictions nor forecasts in themselves, they provide insights which allow today's policymaking and decisionmaking to influence the future. Scenarios are largely semiquantitative or qualitative and judgmental. The validity of the methods used to build plausible scenarios is generally determined by a

consensus of expert opinion. The four scenario package approach described in this report was developed specifically to overcome the uncertainties of single scenario analysis by using a more robust conceptual framework.

The following guidelines were used as a first step in the development of plausible alternative world scenarios.

- o The logic and assumptions of the scenarios must be plausible over time.
- o The scenarios must focus on issues relevant to Army interests.
- o The scenarios must include valid trends and key variables that are realistic and challenge traditional Army stationing, training, doctrine, and employment concepts.
- o The scenarios must be free of disruptive, aberrant, catastrophic, and anomalous events that would nullify their usefulness for long-range planning.

The plausibility of the scenarios, the methods used to develop them, as well as the methods created by the LRSS Group were validated by a seminar conducted by scholars of the J. F. Kennedy School of Government at Harvard University.⁴ The alternative world scenarios are derived from the early 21st century world environment described in Chapter 2 and are extensions or variations of that environment.

The Cone of Plausibility.

The scenarios encompass a transition of trends, events and consequences of the late decades of the 20th century and their likely evolution into the 21st century to the planning focus year of 2020. This transition and evolution form a theoretical cone through the passage of time, i.e., from today to distant tomorrows or futures. Within the cone, cause and effect relationships that define the Army's existence in response to the external world characteristics represent trends that can be tracked from today to any point along a time line into the future. Although use of the cone does not increase the accuracy of the forecast of the scenarios, tracking establishes and reinforces the validity and plausibility of the scenarios. The cone is called "the cone of plausibility."⁵ It is displayed in Figure 1 and described in more detail in Addendum A to this chapter.

Plausible Scenarios.

Scenarios projected within the cone are considered plausible if they adhere to a logical progression of each scenario's trends, events, and consequences from today to the planning focus plane. Moreover, each scenario can be tracked backward or forward in the time cone, e.g., from 2020 through 2005 to the 1990s and back to 2020, as a further test of plausibility. This assures a high degree of compatibility between the present and the future, ergo, the trends and events and their likely outcomes are intermeshed with and provide guidance for the Army Long Range Planning Guidance (ALRPG); The Army

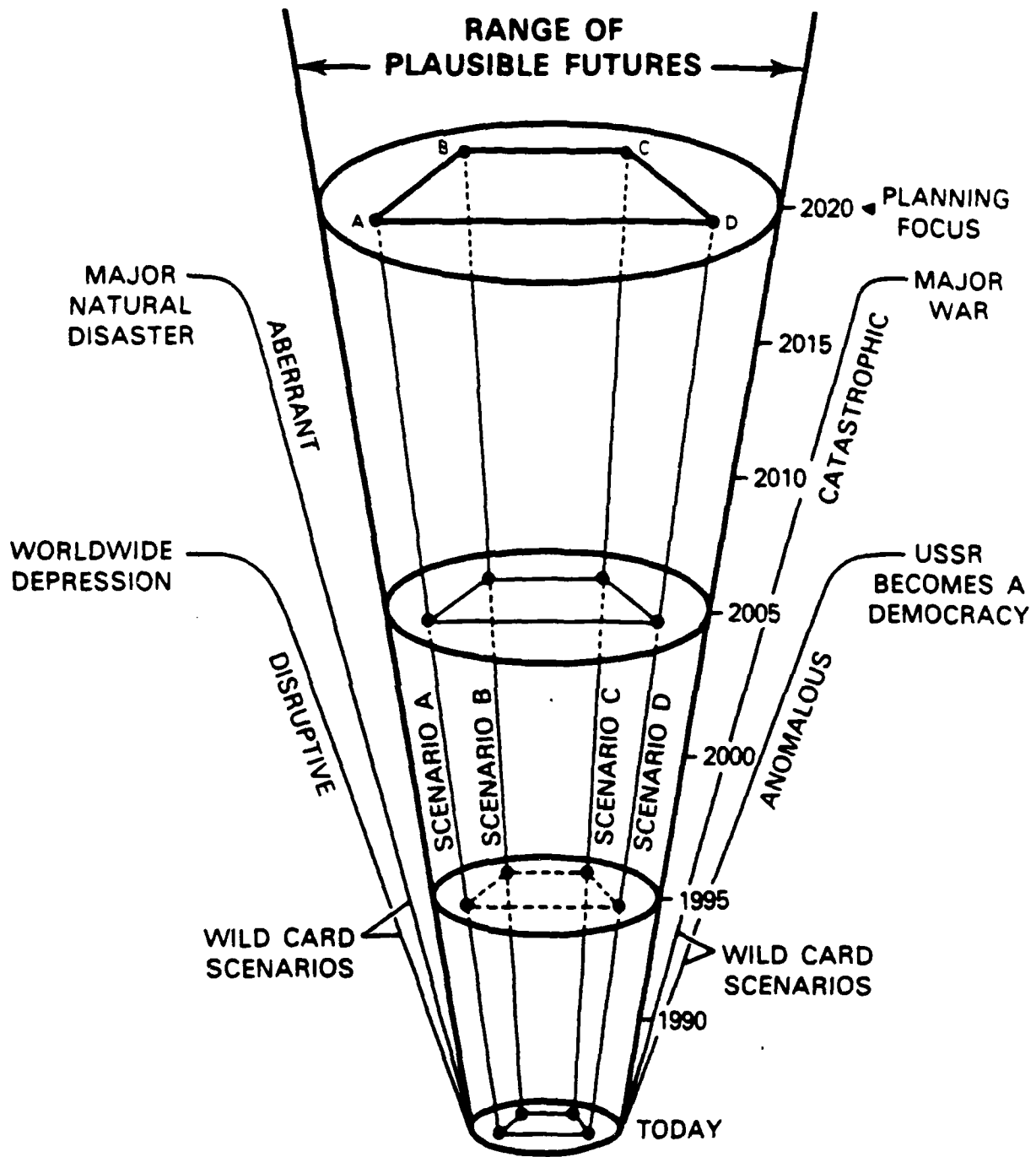

FIGURE 1. THE CONE OF PLAUSIBILITY

Plan (TAP), its direction and orientation; and the Program Objective Memorandum (POM) with its Extended Planning Annex (EPA).

Wild Card Scenarios.

Other trends, events, and consequences, when assembled as scenarios, are considered implausible from today's perspective. These are termed "wild card" scenarios and are outside of the cone by definition. They encompass major disruptive, aberrant, catastrophic, or anomalous events, the occurrences of which are essentially unpredictable (see Figure 1). Wild card scenarios, however, can become plausible at any time, if they occur. When they penetrate the cone, the scenario environments are profoundly altered. In this event, they likely would suspend the logical progression of the scenarios established within the cone until new recovery baselines can be determined and new trends and events can be selected as drivers of the scenarios.

Scenario Drivers.

The trends selected to be the drivers of the scenarios in this report are those that are critical to national and international issues, those that shape the political, economic, social, technological, and military future of the United States and its relationships with other nations of the world. Drivers are plausible, dominant trends and events that establish the general theme of the scenarios and move the scenarios forward in the time cone. Political and economic drivers, national and international, are used to set the themes of the scenarios since U.S. national defense is more sensitive to them than to other drivers. Each scenario includes driver trends that are similar to those of the other scenarios and that have distinct thrust and a direction. When in combination with other scenario trends, the driver trends distinguish the scenarios, one from another.

Although many scenarios could have been created for the LRSS Group, the number was limited to a set of four. The set does not include upper or lower limits, best or worst case, or middle of the road scenarios. None is intended to be the most likely environment or a forecast of the world of 2005 or 2020. Rather, each is intended to describe possible combinations of future conditions that can be used as decisionmaking or policymaking analysis tools.

Notwithstanding the possible independent use of each scenario, the scenarios were designed to be used as a planning package, where planners and analysts can meaningfully compare the influence of variables across time in realistic situations and in an envelope of potential (not predictive) evolving Army configurations. Use of the scenarios in this report could provide the Department of the Army a method by which it can plan realistically for different operating climates, restraints, requirements, and resources for the future. The four scenarios have the following identification and descriptive titles:

- o Scenario ALPHA: U.S. Isolationist;
- o Scenario BRAVO: U.S. World Peacekeeper;
- o Scenario CHARLIE: Neonationalism World; and
- o Scenario DELTA: Muted Bipolar World.

The four basic scenarios, each with its set of four driver statements, are displayed in Table 1. Additional discussion of scenario drivers is contained in Addendum A to this chapter.

Report Organization.

This report is designed to describe a process for the use of alternative world scenarios for strategic planning purposes by Army planners and to provide a set of four scenarios that can be used throughout the Department of the Army. The report is presented in seven chapters.

- o Chapter 1 (this chapter) provided an explanation of a realistic method to derive sets of plausible world scenarios.

- o Chapter 2 describes the background world environment of the early decades of the 21st century from which the alternative world scenarios were developed.

- o Chapter 3 describes how the four scenarios were finalized for the LRSS project and provides a brief synopsis for each of the scenarios for the year 2020 that can be serve as a handy reference for the readers and users of this report.

- o Chapters 4, 5, 6, and 7 contain detailed descriptions for each of the scenarios, ALPHA, BRAVO, CHARLIE, and DELTA, for planning focus years 2005 and 2020, respectively.

SCENARIO ALPHA: U.S. ISOLATIONIST

U.S. national political leaders advocate a strong welfare, social investment economy.

Western postindustrial infrastructures, along with specialty industries, lack the capacity to support national mobilization plans within the WW II framework.

The rise of nationalism worldwide has suppressed U.S. international influence and has precluded U.S. military presence overseas.

U.S. community infrastructures (economies, politics, demographics, resources, attitudes and values, etc.) inhibit military stationing requirements and reduce installation investments.

SCENARIO BRAVO: U.S. WORLD PEACEKEEPER

U.S. national political leaders advocate a strong military defense.

Western postindustrial infrastructures, along with specialty industries, adequately buttress national mobilization plans within the WW II framework.

A tradeoff of nationalism worldwide for economic development has strengthened U.S. international influence and preserved U.S. military presence overseas.

U.S. community infrastructures (economies, politics, demographics, resources, attitudes and values, etc.) underpin military stationing requirements and installation investments.

SCENARIO CHARLIE: NEONATIONALISM WORLD

U.S. national political leaders advocate a strong military defense.

Western postindustrial infrastructures, along with specialty industries, lack the capacity to support national mobilization plans within the WW II framework.

The rise of nationalism worldwide has suppressed U.S. international influence and has precluded U.S. military presence overseas.

U.S. community infrastructures (economies, politics, demographics, resources, attitudes and values, etc.) inhibit military stationing requirements and reduce installation investments.

SCENARIO DELTA: MUTED BIPOLAR WORLD

U.S. national political leaders advocate a strong welfare, social investment program.

Western postindustrial infrastructures, along with specialty industries, lack the capacity to support national mobilization plans within the WW II framework.

A tradeoff of nationalism worldwide for economic development has strengthened U.S. international influence and preserved U.S. military presence overseas.

U.S. community infrastructures (economies, politics, demographics, resources, attitudes and values, etc.) inhibit military stationing requirements and reduce installation investments.

Table 1. Scenario Drivers for Alternative World Scenarios for Strategic Planning.

CHAPTER 1

ENDNOTES

1. The U.S. Army War College, Strategic Studies Institute (SSI) was directed by Chief of Staff Memorandum, U.S. Army (CSM 86-15-14, 6 November 1986, "Long Range Stationing Plan for the Army") to assist the Long Range Stationing Study (LRSS) Group (created by the same CSM) during Phase I of the study by developing plausible alternative scenarios in which the Army may operate in the year 2020. SSI developed the scenarios contained in this document against which the LRSS Group designed and developed its long-range stationing model and process. The initial Study Advisory Group (SAG) consisted of: LTG RisCassi, DCSOPS, SAG Chairman; Mr. Johnson, OASA; LTG Register, DCSLOG; LTG Heiberg, COE; LTG Jenes, FORSCOM; LTG Forman, TRADOC; and LTG Burbules, AMC.

2. All too often, planning is based against a single, unique, and surprise-free scenario that has been derived from a consensus view of a continuation of current trends. In general, a single view of the future tends to be shortsighted and cannot be relied upon (see Richard B. Heydinger and Rene D. Zentner, "Multiple Scenario Analysis," in Applying Methods and Techniques of Futures Research, James L. Morrison, and others, eds., pp. 65-67). For short-term planning (0-2 years hence), however, the surprise-free scenario approach can be reasonably accurate but somewhat less accurate than planning against a set of alternative scenarios for the same time period. For midrange planning (2-10 years), drawing out specific trends and achieving a consensus view becomes increasingly difficult unless expert opinions are obtained through the use of Delphi or cross-impact techniques. For long-range planning (10-20 years), the range of uncertainties, e.g., regarding the continuity of trends and their impact on society, make the single scenario less manageable unless many assumptions can be agreed upon. The surprise-free scenario approach tends to create and accommodate a more subjective future than an objective one.

3. Heydinger and Zentner, p. 66.

4. Robert J. Murray, and others, "Harvard University Seminar on U.S. Army Long-Range Stationing Study," John F. Kennedy School of Government, October 8-9, 1987. The principal participants included Mr. Robert J. Murray, Seminar Leader; Professors Richard N. Cooper, Joseph S. Nye, Jr., and Ernest R. May; Lieutenant General Richard D. Lawrence (USA Ret.); and Army participants Colonels Robert B. Adair, LRSS Director; Stephen F. Rutz, LRSS Deputy Director; and John J. Hickey, Jr., Chairman, Strategy and Planning Department, Strategic Studies Institute, U.S. Army War College. The Seminar reviewed and evaluated the scenarios and issued a report in which the members validated the scenarios and methodology and found the scenarios to be plausible. An excerpt from the "Executive Summary" of the Seminar Report states:

. . . The Harvard faculty participants who reviewed the LRSS agreed that it was a useful exercise that can be extended to other areas of long-range military planning, and they were particularly impressed with the extent to which some of the LRSS scenarios challenged widely-held assumptions about the future structure of the Army. The faculty participants also found the basic methodology of the LRSS to be sound and the outlines of its four scenarios to be plausible. . . .

5. The concept of the "cone of plausibility" originated during the early stages of the development of the scenarios for the LRSS by Stephen F. Rutz, Colonel, USA, and Robert S. McEldowney, Lieutenant Colonel, USA, circa November 1986. The concept was expanded, clarified, and described by the author of this report. A literature search uncovered only one other similar concept of scenario plausibility: a U.S. House of Representatives Committee report: Preworkshop submission by Lynne Hall, Public Issue Early Warning Systems: Legislative and Institutional Alternatives, October 1982, p. 235. Hall, in private telephone conversation with the author on 16 December 1987, related that she used a method of scenario projection (but not a cone) from today to a future area of plausibility as early as 1980 with General Electric Company of Connecticut, again with Shell Canada in 1982, and also in 1982 with the U.S. House of Representatives, Oversight Committee. Hall also stated that she has never published a detailed description of her method of scenario development.

ADDENDUM A

The Cone of Plausibility, Further Discussion.

The cone encompasses the projections of a set of four plausible scenarios, i.e., external worlds and the responses of planners to them. They are identified as A, B, C, and D, and ascend from today to a planning focus plane year of 2020. Although the scenarios individually vary in strength for a particular characteristic, the four scenario package creates a comprehensive political, economic, sociological, and technological holistic set. Each scenario is shown as a point and represents a snapshot on each planning focus plane. Each scenario ascends along a time line maintaining a continuity through incremental time periods from today to the 2020 focus plane.

Within an incremental time period, e.g., five years, any single trend line may actually be straight, angular, or curved. When the audit trails of all trends in a scenario time increment are combined, the projection most often would appear as a straight line. Each successive time increment thus approximates a smooth curve over the thirty year focus of the scenarios. Within any plane there are galaxies of plausible and possible scenarios built from clusters of respective cause and effect relationships. The external world of each scenario on a given focus plane can have any number of plausible planning responses. The fact that each of the designated scenarios, A, B, C, and D, works in concert with the other three captures (mathematically) any other combination of realistic planning responses on a shared planning focus plane. Various responses, for example, are: force structure configurations for heavy, medium, and light brigades in percentage, the number of people, and the number of equipment end items at various technology levels, respectively.

Scenario Drivers, Further Discussion.

The amount of influence that the drivers may have on U.S. national policies and behavior varies in each scenario. U.S. courses of actions in planning and decisionmaking respond to the influence of the drivers to provide a future architecture for U.S. defense. For example, the architecture for the U.S. Armies of the future would include: specific force structure of the total Army, the Army's end strength, technology (weapons systems and supporting equipment), training strategies, demographic and population shifts, and installation characteristics. Moreover, the drivers likely will influence as well how the Army will be employed in the environment of the future. The drivers also serve as precursors and catalysts to bring about new trends and events that become the forerunners for other future world environments. Each of the basic drivers is given a high probability of occurring in the four scenarios. The purpose is to establish a general scenario theme that can be woven into the environment of each scenario.

The initial scenarios are made up of the basic drivers expressed as brief statements. This provides a useful tool for establishing a working relationship between planners who will use the final scenarios and futurists who will gain a better understanding of the level of detail that must go into the final scenarios. The number of basic drivers for this report was narrowed selectively and judgmentally to produce a set of four relevant and plausible

basic drivers in descriptive statements. Each set shapes the conditions and attitudes for an expanded scenario of plausible world environments for 2005 and 2020.

Planners or other scenario users can participate in the scenario development when the drivers are expressed as statements. The planners' perceptions and comprehension of interrelated effects of the scenario drivers permit them to visualize future possible end states for long-range projections that can be used as tentative input to the scenarios. The evolution and plausibility of the scenarios unfold as the basic drivers are expanded and tracked from circa 1988 through 2020. At this stage of scenario development an initial workshop with the LRSS planners generated a separate Army response for each scenario (subject to later refinement). Each response conformed to the environment described in each scenario and constituted a plausible evolution of force structure and end strength (for example) from 1988 to 2020 and so forth.

CHAPTER 2

THE EARLY DECADES OF THE 21ST CENTURY

A Common Background.

A large number of potential future world environments emerge from the world as it exists today. Therefore, a common framework or background is essential for the development of scenarios describing the very long-range future (20-30 years or more). A World 2010,¹ the background used for developing the scenarios of this report, is a description of the world environment based on the projected consequences of 20th century trends. It not only provides an adequate starting point for the building of the scenarios, but also provides a basis for constructing the architecture for a U.S. defense force of the future. A World 2010 is summarized in the following paragraphs. Additional data needed for specific usage of the scenarios, e.g., projected technological advances, can be found in documents in the open literature.

The Assumptions.

The assumptions of this report allow the development of both the background and scenario environments that are free of restrictive world societal events. Any occurrence of catastrophic events affecting the assumptions would create a destabilized world environment in which the trends and events in the scenarios, at most, would not occur or, at least, would be delayed.

- o Neither general war nor a war between the United States and the Soviet Union nor a war among other major powers will occur.

- o Neither a worldwide economic collapse nor major world depression will occur during the next 30 years.

- o No major scientific or technological breakthroughs will occur that will give one world nation the ultimate power of intimidation over all others.

The Trends.

The characteristics of the world environment that are likely to span the period over the next 30 or so years are derived, for the most part, from trends of the last half of the 20th century. These trends, generally recognized by futurists as important to the development of future world environments, are described briefly in this chapter. Continuation of these trends and their consequences into the next century creates the framework for the support of a common background for the scenarios of this report. They include the following:

- o Nations of the world are progressing toward a new international political order.

- o Global population continues to increase.

- o Interdependence among nations continues to increase but in new patterns of economic agreements and competition.
- o Reserves of petroleum and gas continue to decrease as energy sources while use of coal, nuclear, and alternative energy sources rise.
- o Science and technology continue to advance rapidly as do space exploration and use.
- o Sociopolitical changes increasingly are affecting all nations of the world.
- o Proliferation of conventional arms and nuclear weapons continues.

o Nations of the world are progressing toward a new international political order. Through the late 1990s and the early decades of the 21st century, the world order of nations has been drifting from the 20th century descriptive terms of "more developed" and "less developed" nations and from "Superpower" and "Third World" nations to more appropriate national descriptors that revolve about modernization and industrialization. All nations are described in terms of their progress toward industrialization, thereby allowing each nation some status in the world community of nations and broad latitude for economic development. Through a universal linkage of an industrial commonality, former Third World societies likely can develop their self-worth and plan and set national goals, as well as discover opportunities to pursue more self-directed destinies.

Early in the 21st century the more industrially advanced nations will provide various forms of encouragement to the former Third World nations. This not only will assist these nations to progress industrially and economically, but also, in all likelihood, will help them to develop national incentives for avoiding destructive wars. The names of the categories for the 21st century nations are: postindustrial, advanced industrial, transitioning industrial, industrial, and preindustrial. Nations at various levels of development in 2020 in each category are listed in Table 2 and some comparative characteristics that describe each category are shown in Table 3. The abbreviated statements contained in Table 3 are relative to the size, economy, and so forth of nations within each category.

The United States in the early decades of the new century remains (in this new order) the most influential economic and political nation of the world. Its military influence throughout the world is one characterized by its salient capabilities of the past rather than its overt use of military power. The Soviet Union, on the other hand, can be considered an industrial society at the turn of the century. During the 20th century it has been unable to achieve the transition from industrial status to postindustrial throughout its vast country, except in the Soviet European sector. Moreover, the Soviet Union, unwilling to accept its continuing decline to less than a first-rate power, has turned to toward internal economic development, is under new leadership (younger and non-Slavic), and is more adventuresome and competitive economically than it is militarily. As a consequence, it is giving less

POSTINDUSTRIAL

Canada and United States
Europe
Japan
Australia and New Zealand

ADVANCED INDUSTRIAL

Israel
Singapore
South Africa
Taiwan

TRANSITIONING INDUSTRIAL

Argentina
Brazil
Chile
Costa Rica
Mexico

INDUSTRIAL

China
Cuba
India
Korea, N.
Korea, S.
Malaysia
Pakistan
Philippines
Turkey
Soviet Union
Venezuela
Vietnam

PREINDUSTRIAL

All other nations of
Africa, Asia, Latin
America, and Oceania
not listed elsewhere.

Table 2. An Arrangement of Nations by Industrialization and Modernization.²

military support and more economic attention to its 20th century client and surrogate states, as well as allowing them more opportunities to pursue new self-directed destinies.

o Global population continues to increase. Most nations have slowed their rate of population growth by 2005 and some have reached zero growth by 2020. The population growth of others, however, although slightly reduced from that during most of the 20th century, is continuing at a high rate. The increasing population growth in urban areas is significantly adding to societal change. Table 4 shows the population of the world's nations by industrial category.³

o Interdependence among nations continues to increase but in new patterns of economic agreements and competition. Many nations have discarded 20th century economic agreements and have joined new arrangements according to the new industrial patterns and associated common interests of the new century. Although the turn of the century world environment increasingly has been highly competitive, nearly all of the world's nations by 2020 are achieving an economic growth well beyond that ever achieved in the 20th century. Despite recurrent benevolent acts by world organizations and nations, the very poorest of the world's nations continue an economic and national decline toward nonexistence.⁴

CATEGORIES:

SOCIETAL INFRASTRUCTURE	POSTINDUSTRIAL	ADVANCED INDUSTRIAL	TRANSITIONING INDUSTRIAL	INDUSTRIAL	PREINDUSTRIAL
Industrial orientation	Ultramodern, science-based/high-tech oriented for information, service, and knowledge industries; maximum use of outer space	Highly modernized, automated and robotic 21st century manufacturing including the use of space	Modernized industrial/manufacturing and agriculture mostly 21st century	Modern, late 20th century industrial manufacturing and agriculture	Partly industrial to almost completely agriculture
Work force (percent of work force)	Information . . . 33% Knowledge . . . 32% Services . . . 15% Light manufacturing . . . 18% Technoagriculture 2	High-tech manufacturing 35% Light and heavy manufacturing . . . 25% Services . . . 10% Technoagriculture and agriculture . . . 30%	Manufacturing . . 30% Light and heavy industry . . . 30% Agriculture . . . 30% Services . . . 10%	Manufacturing . 15% Light and heavy industry . . . 45% Agriculture . . 30% Services . . . 10%	Light and heavy industry 30% Agriculture and extractive processes 65 Services 5
Political freedom	23 nations: 74% free 13% partly free 13% not free	4 nations: 25% free 75% partly free	5 nations: 60% free 40% partly free	12 nations: 17% free 58% partly free 25% not free	123 nations: 10% free 20% partly free 70% not free
Military forces	Small active forces, large gen. purpose reserve; high-tech trained; most advanced weapons in the world.	Large active highly mobile forces; small reserve force; sophisticated training, technology-oriented; advanced conventional and some nuclear weapons.	Small active and reserve forces; well trained defensively; advanced, sophisticated conventional weapons and some with modest nuclear weapons; Mexico & Costa Rica less capabilities.	Large (relative to country) armed forces; most are highly trained; mix of advanced and modern weapons; SU and China weapons nearly same as post-industrial nations.	Small active forces; poorly trained; mix of antiquated and advanced weapons; some with few to no forces or weapons at all.

Table 3. Some Comparative and Descriptive Characteristics of the Categories of Nations Projected to 2020. 5

	<u>2000</u>	<u>2005*</u>	<u>2020</u>
<u>WORLD POPULATION</u>	6,158.0	6,616.5	7,992.0
<u>POSTINDUSTRIAL</u>			
Total	951.0	956.8	974.6
% of world population	15.4	14.4	12.2
<u>ADVANCED INDUSTRIAL</u>			
Total	75.8	81.3	97.6
% of world population	1.2	1.2	1.2
<u>TRANSITIONING INDUSTRIAL</u>			
Total	351.0	371.1	431.4
% of world population	5.6	5.6	5.4
<u>INDUSTRIAL</u>			
Total	3,046.6	3,225.8	3,763.2
% of world population	49.4	48.7	47.1
<u>PREINDUSTRIAL</u>			
Total	1,752.2	1,993.6	2,717.6
% of world population	28.4	30.1	34.0

* Extrapolated data.

Table 4. Projected Population Estimates, 2000, 2005, and 2020 (in millions).
Source: Population Reference Bureau, Inc., 1987.

o Reserves of petroleum and gas continue to decrease as energy sources while use of coal, nuclear, and alternative energy sources rise. Nearly all nations are aware that oil and gas supplies very likely will be approaching depletion during the latter half of the 21st century⁶ leaving many nations dependent on coal and nuclear power for energy sources. By 2020, about 40 nations may have acquired nuclear power plants to satisfy their energy needs, as displayed in Table 5.⁷

o Science and technology continue to advance rapidly as do space exploration and use. Most of the nations of world 2020 are benefiting from the latest and most advanced science and technology; nearly all share in these advances except for the very poorest of the preindustrial nations which are recipients of mostly appropriate technology.⁸ Increasingly, by the year 2020, the transfer of technology can be expected to flow unimpeded worldwide as will information. Almost all nations are profiting from advances and achievements of space exploration and use, especially the almost instantaneous communications of the occurrence of events worldwide via satellites. Many nations are involved in the cooperative use of space stations and in the participation of commercial ventures with space platforms and laboratories. The cost-benefits of the peaceful development and utilization of space by 2020

can be expected to far outweigh the uncertainties and risks of any military use other than basic peacekeeping needs such as observation, navigation, and weather.

o Sociopolitical changes increasingly are affecting all nations of the world. By the year 2020, most of the world's nations can be expected to experience dramatic sociopolitical reorientation relative to their new status in the order of nations. As new industrial and economic infrastructures come into being, national leaders as well as the general populace of each nation likely will form new views of and make modifications to their internal political processes and societal structure. Unless technology can provide remedies, however, ignorance and apathy are likely to result in new geographical patterns of pollution in and around the new industrial countries. Paradoxically, a new growth of nationalism can be expected also to arise in most nations which likely will weaken 20th century world cooperative movements, e.g., the New International Economic Order; and international organizations, e.g., the United Nations, as well as alliances such as NATO and the Warsaw Pact. The spread of free enterprise worldwide increasingly could promote a rise of capitalism, a preference by many people for more representative government, and a realization of human rights and social justice.⁹

POSTINDUSTRIAL

Austria
Belgium
Bulgaria
Canada
Czechoslovakia
Finland
France
Germany, East
Germany, West
Hungary
Italy
Japan
Netherlands
Poland
Romania
Spain
Sweden
Switzerland
United Kingdom
United States
Yugoslavia

TRANSITIONING INDUSTRIAL

Argentina
Brazil
Chile
Mexico

INDUSTRIAL

China
Cuba
India
Korea, North
Korea, South
Pakistan
Philippines
Soviet Union
Vietnam

ADVANCED INDUSTRIAL

Israel
Singapore
South Africa
Taiwan

PREINDUSTRIAL

Egypt
Iran
Iraq
Saudi Arabia

Table 5. Estimate of Nations Possessing Nuclear Power Plants in 2020.

Both the United States and the Soviet Union can expect to undergo cultural changes by the early decades of the new century that are likely to alter their societies. The United States, for example, because of legal and illegal immigration across its southern border as well as across the Pacific, increasingly will be approaching a population composition that is half black, Hispanic, or Asian;¹⁰ a distribution where the white, non-Hispanic/non-Asian influence, in all likelihood, will no longer dominate U.S. national and international interests and policies. Similarly, the Soviet Union in these early decades likely will experience generational and attitudinal changes as well as ethnic changes in leadership (e.g., to a traditional, younger non-Slavic ethnic group). Such happenings likely could result in significant changes in Soviet internal as well as external interests and policies.¹¹

o Proliferation of conventional arms and nuclear weapons continues. Proliferation of conventional arms throughout most of the world will continue as will nuclear weapons.¹² Most industrial nations of the world are armed with a range of conventional weapons that was supplied to them during the 20th century, mostly by the superpower nations and their allies. Many continue to purchase or barter for the latest state-of-the-art high-tech conventional weapons which are available from new 21st century arms suppliers who have replaced the arms merchants of the old century. During the last few decades of the 20th century, proliferation of nuclear weapons in all probability can be expected to increase to 20 or more nations; as shown in Table 6.¹³ Almost all nations of the world are involved in highly competitive economic activities. Most nations are experiencing an economic growth unprecedented in their histories, and, although they appear to show little inclination toward armed conflict, they are aware of the complex relationship between prosperity and conflict. Moreover, most recognize the need to maintain an arsenal of weapons, since economic growth is not a necessary or sufficient condition for peace.

Summary.

U.S. national challenges can be expected to fall into several categories by 2020, foremost of which will be a national educational system followed by those of a national economy, a national defense, a national space program and national science and technology efforts. U.S. national threats can be expected to be many if viewed only from a 20th century perspective. Unlike 20th century threats to U.S. political interests which were predominantly military in character, those of the early decades of the 21st century are likely to be more economic in character. To meet these threats, the United States will have to replace its reliance on strategies of military force with a reliance on strategies of economic influence.

The environment created in world 2020 essentially encompasses a peaceful world. It is, however, an environment where world economic competition and tensions are high and where armed conflict, as a means for nations to protect their economic infrastructures, remains an ever present possibility. Because most nations of the world are realizing economic growth and are beginning to achieve national goals of internal development, war in any form is an unpopular activity. The notions of being armed,

POSTINDUSTRIAL

France²
Japan⁴
United Kingdom²
United States¹

ADVANCED INDUSTRIAL

Israel²
South Africa⁴
Taiwan³

TRANSITIONING INDUSTRIAL

Argentina⁴
Brazil⁴
Chile⁴

INDUSTRIAL

China²
India²
Pakistan²
North Korea³
South Korea³
Soviet Union¹
Vietnam⁴

PREINDUSTRIAL

Egypt⁵
Iran⁵
Iraq⁵
Libya⁵
Saudi Arabia⁵

1= substantial, 1000-2000 or more; 2= significant, 1000 or less;
3= moderate, 500 or less; 4= modest, 100 or less; 5= very modest,
50 or less.

Table 6. Hypothetical Estimates of Nations Possessing Nuclear Weapons and Delivery Means in the Year 2020.

having modern high-tech weapons, and, for some nations, having nuclear weapons and a means to deliver them, remain psychologically attractive. These national attitudes, shared by nations that are expressing a new self-directed economic individuality, create an environment of a world in 2020 filled with apprehensions and anxieties where U.S. national security leadership must be alert and prepared to deter or terminate quickly conflicts that threaten U.S. interests. The environment of 2020 creates many challenges to and concerns for a postindustrial United States which will require the utmost in national innovativeness and creativity and in the skills of strategic planning and decisionmaking.

CHAPTER 2

ENDNOTES

1. Adapted and summarized from Charles W. Taylor, A World 2010: A Decline of Superpower Influence. (Hereafter referred to as A World 2010.) The following tables in this report are also from A World 2010: Tables 2, 4, 5, and 6 and have been modified for this report.
2. The arrangement of nations in Table 2 by industrialization and modernization (Taylor, A World 2010, pp. 2-9) was developed to substantiate the trend that the world is drifting away from political ideological bipolarity to a world of economic multipolarity. The broad latitude created in a devolution of power world allows new economic agreements, alliances, and partnerships to form. It also allows states to achieve new levels of economic statehood, even to be carried along with a group. For example, all of Europe is categorized as postindustrial, including Albania and Bulgaria; these two states are unlikely to achieve such a status on their own. They are symbolically carried along with the other Western and Eastern European nations to complete the general notion of this 21st century arrangement of nations.
3. Carl Haub and Mary Mederios Kent, 1987 World Population Data Sheet.
4. Adapted from Ann Crittenden, "I.M.F. Aid Up Sharply; Focus on Poorer Nations," The New York Times, May 13, 1980, p. D-8; see also American Council of Life Insurance, "Collapse of Global Financial Superstructure," pp. 15-18.
5. The general concept for the development of Table 3 is an adaptation from Graham T. T. Molitor, "The Information Society: The Path to Postindustrial Growth," in Communications Tomorrow: The Coming of the Information Society, ed. by Edward Cornish, 1982, p. 85; and also from Yoneji Masuda, The Information Society as Post-Industrial Society, 1981, pp. 29-33. The "Political freedom" entry in Table 3 is an adaptation from Raymond D. Gastil, "The Comparative Survey of Freedom 1988," Freedom At Issue, No. 100, January-February 1988, pp. 19-35. Gastil describes the political and economic systems of nations as they relate to each nation's political and civil freedoms. Nations are rated against scales for political and civil freedoms, with a political free baseline of a fully competitive electoral process where those elected clearly rule, and a civil liberties baseline where freedom of public expression for political change is not closed and where courts protect individual expression. Gastil includes a partly free category where there is overlapping of either political or civil freedoms. Gastil's comparative surveys present only his estimates of the current year's situation and the progress made toward freedom; he does not forecast the probability of freedom. The projections for the world 2020 in this report are those of the author and are based on estimates of the economic and political potential of nations.
6. John Gever and others, Beyond Oil: The Threat to Food and Fuel in the Coming Decades, January 1986, pp. 54-65, 144. Gever and others believe that world oil production will peak around the year 2000 and that substitutes cannot fully offset the decline in petroleum before 2025. They also believe that U.S. oil and gas virtually will be exhausted by 2020.

7. Adapted from Taylor, A World 2010, p. 14.
8. Adapted from Jacques Gansler, "The U.S. Technology Base: Problems and Prospects," in Technology, Strategy and National Security, edited by Franklin D. Margiotta and Ralph Sanders, pp. 110-111.
9. Leon F. Bouvier, "Planet Earth 1984-2034," Population Bulletin, pp. 18, 19, and 24.
10. Adapted from American Council of Life Insurance, "New Immigrants, New Minorities," by Leon Bouvier, pp. 15-17.
11. Adapted from Bouvier, "Planet Earth," pp. 15, 16, 27, and 29; see also Joseph Adamek, Centrally Planned Economies in Europe: Economic Overview 1985, p. 11.
12. Arthur F. Manfredi and others, Ballistic Missile Proliferation Potential in the Third World, pp. 5-6; and discussion by Richard F. Grimmett, in Trends in Conventional Arms Transfers to the Third World by Major Suppliers, 1978-1985, various places.
13. Adapted from Taylor, A World 2010, p. 23.

CHAPTER 3

SCENARIO SYNOPSES AND ATTRIBUTES

Development of the Scenarios.

The cone of plausibility, the method by which four alternative future scenarios for this report were created and selected for purposes of long-range planning of national security and defense interests, was described in Chapter 1. The basic drivers (the political and economic elements) were identified by LRSS, Army Staff, Major Commands (MACOM), and Reserve component planners at an initial workshop. The results were set down side by side as four basic driver trend statements and returned to a second workshop where initial Army responses were determined by a planning team that included the Army Staff, MACOM, and Reserve component members. The second chapter broadened the perception of the future for the planners by projecting selected and germane trends some 30 years (to about 2020) to create a common background for further development of the scenarios. The purpose of this chapter is to describe the method of finalizing the scenarios and provide a synopsis of each scenario that will serve as a reference for readers and users of this report. Finally, this chapter includes a listing of important attributes of the scenario environments with suggested attribute values across the four scenarios for comparative purposes.

Finalizing the Scenarios.

In general, the method for finalizing the scenarios includes two additional workshops where the planners participate with the scenario writer (the futurist) to review the results of the previous workshops then provide an updated Army response to the four alternative scenarios before they are written in final form as presented in the next four chapters.

In the third workshop the planners reconsidered their original Army responses to driving trends of the four scenarios, now rearranged by the futurist (the scenario writer) in an order of theme dominance, i.e., in an order of their probability to influence U.S. plans, policies, and behavior. The reason for changing their order is based on the notion that there are specific trends and events that, at any one point, are foremost in a society, often preoccupying the society. These trends tend to dominate the direction that most other trends and events likely will take in the near future. For example, the OPEC oil embargo of 1973 set in motion a dominant trend that indicated a long-term shortage of gasoline. This trend in 1973 was plausible and the long lines at gas station pumps and the daily increase in the cost per gallon made it very real. It altered the direction of most other trends and events, such as noted in the automotive, recreational vehicle, and tourism industries, for the duration of the embargo and beyond for some time.

When applied to the scenarios at this point of their development, they begin to show direction and body. For example, in scenario BRAVO, the worldwide trend for economic development that strengthens U.S. global influence and preserves U.S. overseas bases is the dominant theme that

overrides and permeates all other themes within the scenario BRAVO. Whereas in scenario DELTA, that same theme has less probability of influence and the dominant theme is the trend concerning the attitude of the U.S. public. This method of approach to scenario writing assists in maintaining realism and adds variety in long-range planning. The rearranged basic driver trend statements for the scenarios are displayed in Table 7.

The themes of each of the driver-statement-scenarios are then expanded in detail by the scenario writer to one page for 2020. The expanded theme descriptions for the four scenarios are provided as Appendixes A, B, C, and D to this report. The planning team in a fourth workshop again reviewed and modified (if necessary) earlier Army responses to the scenarios based on the new information. The additional insights, perceptions, and historical perspectives (from 1990 to 2005 to 2020) provided by the planners assisted in assuring that the scenario writer was aware of and addressed the major related concerns of the planners for 2005 and 2020. The close workshop relationships and the opportunities for communication between the futurist and the planners are firm requirements for the development of scenarios. Beyond the LRSS scenario workshops, communication was enhanced by telephonic-computer networking since the planners and futurist were remote from each other. The single most important advantage of this is that the futurist designs the scenarios and describes the future implications that challenge the skills of planners and policymakers.¹ In those cases where planners or policymakers design the scenarios instead of futurists, the environments are often written so that they accommodate planning and policy goals. A responsibility of the futurist is to maintain the integrity of the scenarios.

Upon completion of these two steps, the final scenarios can be prepared by the scenario writer. The final Army responses and their plausibility, however, are based on resource constraints posed by the economic environment that is embodied as a variable in each respective scenario. A synopsis of each of the final four scenarios of this report is presented below. Each includes the basic scenario drivers and the planning team's notional responses² to each scenario.

Synopses of the Scenarios in 2020.

Some of the differences between the scenarios are readily apparent in these synopses. They are summarized here to aid those who will use the scenarios for planning or policymaking purposes. The synopses are set in the context of the time period around the year 2020.

Scenario ALPHA: U.S. Isolationist. This scenario describes a relative peaceful world where the U.S. perception of an external threat is low. In this international environment, the United States has turned somewhat toward isolationism. In general, the concerns of the U.S. leadership are directed more toward greater budgetary investments in social and welfare programs than in programs for defense or for foreign economic and military aid. For the most part, U.S. and other Western postindustrial infrastructures lack the capacity to support a major industrial mobilization comparable to the surge capability of mid-20th century. A rise of nationalism throughout nations of the world including nations with prior long-term agreements with the United States has suppressed U.S. international influence as well as precluded U.S.

SCENARIO ALPHA: U.S. ISOLATIONIST

U.S. national political leaders advocate a strong welfare, social investment economy.

Western postindustrial infrastructures, along with specialty industries, lack the capacity to support national mobilization plans within the WW II framework.

The rise of nationalism worldwide has suppressed U.S. international influence and has precluded U.S. military presence overseas.

U.S. community infrastructures (economies, politics, demographics, resources, attitudes and values, etc.) inhibit military (stationing) requirements and reduce installation investments.

SCENARIO BRAVO: U.S. WORLD PEACEKEEPER

A tradeoff of nationalism worldwide for economic development has strengthened U.S. international influence and preserved U.S. military presence overseas.

Western postindustrial infrastructures, along with specialty industries, adequately buttress national mobilization plans within the WW II framework.

U.S. national political leaders advocate a strong military defense.

U.S. community infrastructures (economies, politics, demographics, resources, attitudes and values, etc.) underpin military (stationing) requirements and installation investments.

SCENARIO CHARLIE: NEONATIONALISM WORLD

The rise of nationalism worldwide has suppressed U.S. international influence and has precluded U.S. military presence overseas.

U.S. community infrastructures (economies, politics, demographics, resources, attitudes and values, etc.) inhibit military (stationing) requirements and reduce installation investments.

U.S. national political leaders advocate a strong military defense.

Western postindustrial infrastructures, along with specialty industries, lack the capacity to support national mobilization plans within the WW II framework.

SCENARIO DELTA: MUTED BIPOLAR WORLD

U.S. community infrastructures (economies, politics, demographics, resources, attitudes and values, etc.) inhibit military (stationing) requirements and reduce installation investments.

U.S. national political leaders advocate a strong welfare, social investment program.

Western postindustrial infrastructures, along with specialty industries, lack the capacity to support national mobilization plans within the WW II framework.

A tradeoff of nationalism worldwide for economic development has strengthened U.S. international influence and preserved U.S. military presence overseas.

Table 7. The Scenario Drivers Arranged in Order of Theme Dominance.

military presence overseas. Increasingly, U.S. community infrastructures (economies, politics, demographics, resources, and others) are inhibiting military stationing requirements and installation activities and investments. The Army budget has dropped significantly to about \$55 billion. Army combat forces are 15 percent heavy, 50 percent medium, and 35 percent light. Only about half of the Army forces are equipped with high-tech, state-of-the-art, equipment. The Active Army strength hovers at 350 thousand and the Reserve forces at 750 thousand.

Scenario BRAVO: U.S. World Peacekeeper. This scenario describes a competitive world of economic trade where external threats, both economic and military, to U.S. and allied interests are perceptibly increasing. Worldwide U.S. economic and military assistance agreements are backed by a large U.S. peacekeeping military force. Assignment tradeoff of nationalism for economic development by many nations worldwide has preserved U.S. military presence overseas and strengthened the international influence of the United States. Despite deindustrialization since the latter half of the past century, Western postindustrial infrastructures can support industrial mobilization, even surge. U.S. leadership in the Congress and Administration advocate a strong military defense. The Army budget alone has increased to \$105 billion. Army combat forces are 40 percent heavy, 10 percent light, and 50 percent medium. In general the total force is about 60 percent high-tech. The Active Army strength is about 850 thousand troops with a Reserve component of 1.7 million troops. The Soviet Union has also increased its military forces and is a larger threat to world peace now than it was in 1990. This threat has forced the United States to enact a universal public service program which includes the military services and provides a constant source of trained troops.

Scenario CHARLIE: Neonationalism. The rise of nationalism worldwide has significantly suppressed U.S. political, economic, and military influence and has eliminated the presence of the U.S. military overseas. It is a highly competitive world where economic trade wars and restrictions abound. External threats to U.S. interests are more of a challenge to U.S. economic trade than to political ideology. The U.S. leadership has provided substantial budgetary support to social and welfare programs. This has constrained U.S. security to a small, high-tech military force and reduced the Army budget to about \$120 billion. Although U.S. community infrastructures tend to inhibit military stationing requirements and to reduce installation investments, the general public opinion of military service is high. Despite U.S. national political leaders advocating a strong military defense, military end strength is low. The Active Army consists of 225 thousand troops and the Reserves are at 1.3 million. The Army's combat forces are 10 percent heavy, 40 percent light, and 50 percent medium. They are 100 percent high-tech in weapons and other equipment.

Scenario DELTA: Muted Bipolar World. This scenario describes a productive economic world where U.S. political leadership favors social and welfare investments over those of defense and where U.S. communities increasingly object to military activities at bases in or nearby the communities. The external threat to U.S. and allied interests is generally perceived to be about the same as it was in the early 1990s, although the Soviet threat is slightly less. U.S. international influence has been strengthened by most nations worldwide making a tradeoff of nationalism for

economic growth. With reduction of Army presence overseas, its budget is at \$85 billion. Congress is considering combining the Army, Navy, and Air Force into one service. The Army combat forces in this scenario are 60 percent heavy, 20 percent medium and 20 percent light. The Army is about 75 percent high-tech with an Active component strength of 750 thousand troops and a Reserve of 1.2 million.

Attributes of the Scenarios in 2020.

When a scenario is in final form various conditions and attitudes are created. They reflect the intensity and direction of the scenario drivers, express the overall character or composition of the scenario, and vary from one scenario to another. These are scenario attributes that can be observed or assumed to exist in the scenario environments. They are variables that are dependent on the scenario drivers and, where possible to quantify, can be expressed as a range. These attributes are important to the reader and user of the scenarios since they aid in the understanding of the scenarios. Where the scenarios bear close similarity in design and content, as is the case of the scenarios of this report, the attributes can be compared from one scenario to the next. Table 8 displays 15 attributes that are shared by the alternative world environments of this report and includes a suggested baseline value and a relative value for comparison of the scenarios in the end year of 2020. Using these suggested data, planners can structure intermediate scenario snapshots consistent with the basic scenarios and the variations of the attributes will vary from one time increment to the next.

<u>SCENARIO ATTRIBUTE</u>	<u>BASELINE*</u>	<u>ALPHA</u>	<u>BRAVO</u>	<u>CHARLIE</u>	<u>DELTA</u>
Global economy (Growth 2%-5%)	4%	2%	4.5%	4%	2%
Global nationalism	M	H	L	H	L
U.S. global military deployment (Forces deployed 0-500K)	500K	0-50	500	105-200	250-300
U.S. economy (Growth 1.5-3%)	3%	1.5-2%	2.5-3%	2-2.5%	2-2.5%
U.S. trade dependency (10-20% of GNP)	12%	10-15%	15-20%	10%	15%
U.S./Allied relationships (Poor to Good)	G	P	G	P	G
U.S. Army overseas (0-300K)	250K	0-10	300	10-25	150-200
U.S. local acceptance of military bases	H	L	M-H	L	L
U.S. public image of military service	H	L	H	H	M
U.S. defense spending (5-10% of GNP)	6.5%	5%	9-10%	7-8%	6%
Soviet economic growth (2-6%)	4%	2-4%	3-5%	2-5%	2-4%
Soviet military growth (1-4%)	2%	1-2%	3-4%	2-3%	2-3%
U.S. perceptions of security threat	M	L	H	L-M	L-M
W. European perceptions of threat	L-M	L	H	L	M
Nuclear weapons proliferation (9-20 nations)	L	H	L	M	L

*Key to letter ranges: H = high; M = medium; L = low; G = good; P = poor.

Table 8. Comparison of Scenario Attributes for 2020.³

CHAPTER 3

ENDNOTES

1. See Charles W. Taylor, The Relationship of Forecasting to Long-Range Planning, 1982.

2. The numbers in this report for Army responses, here and elsewhere, are notional and have not been validated by the Long Range Stationing Study decision process; validation can be expected to take place in FY 89.

3. The Harvard University participants provided authoritative recommendations and contributions in their review of the attributes matrix. Their suggested correlations of attribute values to the scenario environments make the scenarios more plausible and usable. Their contribution of the baseline column, additionally, provides planners a valid starting point for projecting planning interests into the future.

CHAPTER 4

THE ALTERNATIVE WORLD SCENARIOS: THE ALPHA SCENARIOS

Section I. ALPHA 2005.

The United States by the year 2005 continues to evolve as one of the foremost postindustrial nations of the world. Since the early 1990s, the U.S. leadership (both the Administration and the Congress), by popular demand and championed by a politically active and powerful aging population, has sponsored and achieved increasingly more social and welfare oriented domestic programs than programs related to national defense or foreign military aid. In addition, programs budgeted for environmental protection, education, and space exploration have gradually surpassed those for defense programs, which are followed in their turn by lower budgets for science and technology.

Throughout the United States over the past decade or so, the distribution of Federal funds has resulted in an increase in Federal, state, and local environmental protection legislation and regulations. Despite the Department of Defense position that these regulations are encroaching upon military installations, the growing political influence of environmentalists has forced the closure of a number of military installations. The land has been turned back to the states for state and local use. This currently popular attitude is not an expression of an antimilitary sentiment; it does, however, support a growing public belief that most military activities belong in low-density population areas. A contributing factor to these attitudes has been the overcrowding of military bases by forces returning from overseas bases. Because of the reduced stationing facilities in the states, 30-40 percent of returning units have been deactivated or assigned to the Reserves.

Another factor contributing to the public's attitude, which has lessened most local communities' need for financial support from military installations, has been a gradual rising of national economic growth and employment rate (unemployment is down). Moreover, problems for military installations are exacerbated further by the growing U.S. population along with the increasing number of light (specialty and high-tech) industries, either or both of which have surrounded and, in some instances, encroached upon several military installations. Increasingly since the late 1990s, the abundance of job opportunities available in the high-tech postindustrial U.S. society has resulted in a general nationwide attitude of disinterest in the military and a greater interest and awareness in community development by Federal and state governments as well as by the general public.

The Congress, in order to accommodate the growing need for all citizens to be trained and to develop new skills for the U.S. postindustrial society, passed in the year 2000, a federally subsidized, 18-month public educational program (PEP) that is now completely operational. PEP encourages all interested citizens and residents over 19 years of age and without regard to race, creed, sex, or disability, to enroll for the full program with an option on completion for outstanding trainees to continue careers in public service in the various Federal, state, or local governments. Competition by the various Federal departments for high quality PEP trainees is quite keen. The

Defense Department, within this competition, is faced with an increasingly difficult task of acquiring the caliber of volunteers it needs for its specialized military programs.

Increasingly, over the past decade, the industrial base of a number of Third World nations has been expanding due to a relocation of many heavy industries (e.g., chemicals, steel and iron, automobile production, arms manufacturing, and building and construction supply businesses) from the United States and other Western nations primarily, and from Japan and some of the East European nations as well. While the new Third World industrial base is increasing employment, raising the overall standard of living and providing encouraging economic growth, it also is creating an increasingly competitive world economy. Many of these Third World countries, concerned with the need to protect their interests, have been armed with late 20th century weapons, mostly conventional, by the arms merchants during that era; while others now are buying new and affordable high-tech weapons systems from the new 21st century arms merchants and a few, openly or secretly, are investing also in nuclear weapons and delivery systems to build or increase their arsenals.

The combined effect within many of the Third World countries of new economic status (i.e., a transition from Third World nations to more industrialized nations) and new-found regional political power, along with the cultural strangeness of and unfamiliarity with new technology, has encouraged a rise in nationalism and independence. While most of the Third World countries currently are considering nationalizing foreign industries, some not only have already done so but, selectively, they also have ousted many foreign personnel. Additionally, while some of these same countries have requested that foreign nations close their military bases, others, despite long-term political and military agreements, have been more aggressive, have denied overflight and port visitation rights, and have reclaimed the lands of foreign military bases located on their territories.

The Western postindustrial nations, faced with a declining industrial infrastructure, especially in heavy industry during the past several decades, still retain a residual industrial capability. The Western nations (including the United States), however, are concerned currently that, if this industrial decline continues, they likely will lose the capacity to support national industrial mobilization plans should war occur. Western Europeans, disillusioned by the apparent turn toward isolationism by the United States, its waning interests in and commitments to NATO, the U.S./Soviet mutual force reductions in Europe (about 65 percent of the U.S. forces in Europe, the Pacific, and other overseas regions have returned to the United States over the past decade) along with the gradual U.S./Soviet nuclear weapons reductions that began in the late 1980s, are encouraging East European participation in the European Economic Community rather than strengthening their 1990s war fighting capabilities.

Meanwhile, the Soviet Union over the past decade has been increasing its efforts to improve internal economic development. Despite this Soviet retrenchment (an equivalent withdrawal of its forces from East Europe), the Soviet Union remains a formidable military power but with more aging and obsolescent weapons than new 21st century systems. The Warsaw Pact remains more of a paper tiger than an effective military organization as the Soviet

and East European economies increasingly are bolstered by growing East-West economic ties. Moreover, the Soviet Union by 2005 is becoming more economically than militarily adventuresome and unpredictable. Additionally, Soviet space adventures, less costly and more numerous than those of the United States since their successful Mars landing in the 1990s, offer more favorable world publicity than military adventures. The ousting of U.S. forces from some of Third World countries, however, has encouraged the Soviet leadership to seek economic, political, and military ties with those countries, which are no more interested in a Soviet presence than they were in that of the United States.

The combined impact of world and domestic events by 2005 increasingly is thrusting the U.S. defense strategy toward one of isolationism and is returning the United States and the Soviet Union, again, toward reliance on a strategic nuclear deterrent. All of the U.S. services are beginning to face force reductions as well as shrinkage of installation accommodations. The U.S. Navy (surface, subsurface, and air) is becoming the bulwark of the U.S. continental defense. Although the Air Force is encountering budgetary and personnel reductions as well as installation closings, its bomber force of aging aircraft retains a strategic, albeit deteriorating, capability. Its strength, however, remains in its strategic warning and space surveillance capabilities and its limited strategic defense systems in space. During this early period in 2005 of overseas force withdrawals, troop and budgetary reductions, and installation closings, the Army is being challenged increasingly with the problems of mission management and retention of an adequate defense posture. The U.S. armed services are reorganizing into a peacetime Joint/Unified configuration.

A Ground Defense Force (GDF) in 2005 has been organized into regional commands which include the Active, Reserve, and civilian components. The total force is about 50 percent light (rapidly deployable); the Reserve component is about 75 percent heavy (not readily deployable). Overall, 65 percent of U.S. forces have been withdrawn from overseas. The active ALPHA 2005 land force is comprised of about 300-600 thousand troops whose capabilities are oriented toward low intensity conflict, with almost all units assigned to Unified Commands. They are supported by a Reserve component, which includes both Reserve and National Guard, of about 900 thousand to 1 million troops and by a civilian component of about 250-350 thousand trained personnel. Equipment for the Active and Reserve component of the GDF in 2005 is about equally distributed in 21st century high-tech equipment, 1990s vintage equipment, and older equipment of 1980s vintage that is near obsolescence. The deployment of the ground forces in 2005 is heavily dependent on civilian facilities for air and seaports of embarkation. The ALPHA 2005 land forces, for the most part, use home-station training with computers and exercises with simulation devices. Unit training for the total force is by simulation conducted at regionally leased training centers which use about 80 percent contractors as trainers. Installations, where possible, have multipurpose use and are about 80 percent contractor operated. Increasing social investment policies of the Federal Government provide a quality-of-life to the GDF which is comparable to that of the general society. Sustainment of the ground forces in 2005, however, is considerably reduced because of these same social investment policies.

Section II. ALPHA 2020.

In the year 2020, the United States is recognized internationally as the foremost economic postindustrial country of the world. It is faced, however, as it enters the year 2020, with a mild economic slump well short of a full recession, where the general economy is slightly declining and operating partially below capacity. Increasingly over the past decades the U.S. political leadership, the Administration and the Congress, has expanded federal support to improve social welfare programs. Moreover, the leadership in 2020 is so supportive of these social programs that the United States is skewed decidedly toward a social investment economy. Budgetary support of social programs (which are over 70 percent of the national budget) is followed by national education, space, defense, and science/technology programs. Defense programs have dropped to a low of about \$55 billion. Most national strategists believe that this obsessive national trend in social investments by the U.S. leadership demonstrates a serious neglect of the other programs of the nation, especially those involved with national security. This same trend, however, has been occurring in most of the other free-world nations as well.

By the year 2020, the growth of the U.S. population (more than 300 million) in general and the growth in and around U.S. cities (more than 85 percent of the U.S. population are urban dwellers), especially those cities contiguous to or within a 50 mile radius of military bases and installations, have complicated the stationing of U.S. forces. Training and testing facilities and weapons ranges, which retain 20th century configuration, are affected most. Throughout the states since the turn of the century, the military services have been unable to cope with environmental issues of pollution and resources conservation (especially water) associated with military activities. Additionally, such demographic factors as an older, more conservative electorate along with an ethnic distribution that is approaching half black, Hispanic, or Asian, have brought about a general change of attitude toward war and international involvement. Increasing affluence and leisure time of the average American worker also have brought about activities that are preventing military stationing in close proximity to high density population areas. The additional U.S. communities that have achieved economic self-sufficiency since 2005, collectively, continue to inhibit military stationing and reduce installation investments through lobbies for state and Federal legislation or by outright political activism and demonstrations.

During the past several decades, most of the nations of the world have experienced a period of rising economic growth that has been increasingly challenged by an invigorated, but highly competitive, world economy. In 2020, however, economic indicators are showing a global recessive trend. Concerned over their national economic interests, 60 percent of the nations of the world, except the very poorest, are armed with early 21st century conventional weapons; 20 percent are also armed with the latest high-tech weapons and systems; and 13 percent have nuclear weapons and delivery systems in their arsenals.

Most of the heavy industries, those that made nations great during the past two centuries, essentially have disappeared from the postindustrial states of the United States, Canada, Europe, Australia, and Japan and have

relocated in the industrial states in South, Southeast, and Southwest Asia; China; and South America. Most industries remaining in the postindustrial nations are high-tech oriented and are supported by an increasing number of light, specialty industries. The heavy industrial needs of these nations are imported competitively in the world market. This situation has brought to the forefront the realization that the Western postindustrial infrastructures in the year 2020 lack the capacity to support national mobilization plans.

The new international economic status and the regional positions of prestige and power that began early in the century for the industrial states (some of which were formerly Third World nations) continue to nurture a general rise of nationalism worldwide. This has affected U.S. international political influence adversely and has resulted in the expulsion of all U.S. forces from U.S. overseas bases and port facilities, and in a repossession of the land, regardless of prior agreements with the United States. Most forces that have returned from overseas have been deactivated or have been assigned to the Reserve component. World conditions in 2020 make U.S. reliance on nuclear deterrence more critical than it was at the turn of the century. The deployment of a limited, U.S. strategic missile defense system in space, however, contributes heavily toward the U.S. deterrent posture.

The economic progress that almost all nations have made, along with the absence of any major wars over the past 30 years or so, have outbalanced an armed and militarily competitive world in furtherance of a peaceful but highly economically competitive world. The United States, despite a current, although near-predictable cyclic mild economic slump, remains a prospering postindustrial state while the Soviet Union continues as an industrial state striving to increase its economic growth to achieve a like status. Currently, Soviet interests continue to be directed toward internal economic and social development programs which began in the late 1980s. Although its international trade and economic investment activities since the 1990s have become increasingly more adventuresome and smack of capitalism, historic and traditional Soviet communism and goals remain intact. Notwithstanding, the status of Soviet military power by 2020 has become increasingly more defensive than offensive and its export of ideology is tied more to client-state economic programs than to military programs. Moreover, internal economic growth, the building of more space platforms, and a limited, strategic missile defense system in space, as well as the expansion of its manned Mars station have taken precedence over maintaining a large and expensive military force. The Soviet Union, nevertheless, still remains a substantial military power in 2020, when compared to other industrial nations.

The reorganization of the U.S. armed forces, completed in 2005, that formed a peacetime joint/unified force remains adequate for most contingencies within a one-war strategy. In general, U.S. forces are stationed in available existing installations in low density population areas in the United States that are mostly shared with other federal agencies. The role of the Army in 2020 is mainly defensive and complements nuclear deterrence. The active Army is comprised of a small (250 to 450 thousand troops), volunteer, high-tech, multimission, rapidly deployable Professional Defensive Force (PDF) organized in light units. This force is supported by a larger (700 to 800 thousand troops) single reserve component. The active and reserve forces are supported

by a highly trained civilian component (200 to 250 thousand personnel). In general, the quality of life for the Army in 2020 matches the civilian sector in all respects.

Force structure for the Army is designed to accommodate a unified, joint force for warfighting needs. The Active professional Army component is structured in combat, combat support, combat service support-like units. The total force includes about 15 percent heavy, 35 percent light, and 50 percent medium combat forces. A fifth of the total force is vehicularized land and air units. The Reserve component is structured in four regional commands located in the United States; each with a specific defense mission, but is considerably less deployable than the PDF. The equipment used by the PDF and the Reserve is about half late 20th century and half early 21st century. About one third of the Reserve component is considered ready. Deployment of forces is primarily dependent on post-event, ad hoc alliances with allies providing a major share of land forces. In the event of a conflict, mobile operational bases (sea and air) are of utmost importance for the PDF. The U.S. forces, in general in 2020, are making greater use of robotics as well as intelligence and antiweapons provided by advanced space technology. Additionally, the Army by 2020 is using home-station training, existing and available regional training centers, and leased areas of land for mission training purposes. Operational training for combat is accomplished through the use of variable computerized simulations and simulators, which are especially important for training with advanced weapons systems that have near infinite ranges.

Advocates of a strong U.S. defense are faced with a postindustrial infrastructure that lacks the capacity to support mobilization plans; are confronted with the loss of U.S. overseas bases, overflight rights, and port visitation facilities; and are opposed by local communities throughout the nation that are inhibiting military stationing and forcing reductions in military installations. Moreover, behind the apparently peaceful and economically competitive but viable world in 2020, a latent threat to world peace and U.S. interests exists, especially if nations resort to the use of military actions rather than the use of economic strategies.

CHAPTER 5

ALTERNATIVE WORLD SCENARIOS: THE BRAVO SCENARIOS

Section I. BRAVO 2005.

Over the past decade most of the nations of the world, especially the Third World countries, increasingly have encouraged the presence of the United States. The presence of U.S. industries, businesses, and military has nurtured new economic growth in the Third World along with an orderly transition of many of these nations to modern industrial statehood. Through its good offices, economic aid, and industrial leadership, the United States is raising the national pride of the Third World nations while protecting and furthering U.S. national interests. Moreover, U.S. presence reassures the continued retention of U.S. overseas military bases as well as overflight and port visitation rights. Other nations of the world in 2005, additionally, are seeking U.S. leadership, closer relationships, and economic assistance and guidance. These new relationships between most of these newly industrializing nations and the United States are resulting in firm bilateral economic and political/military agreements with opportunities for new U.S. base and overflight rights. Several of the agreements (e.g., Malaysia, Mexico, the Philippines) formed since the start of the century have been less formal than the 20th century treaties and agreements.

During the past 20 years or so the postindustrial nations, the United States, Canada, Europe, and Japan, increasingly have experienced deindustrialization. Heavy industries such as steel, chemical, arms manufacturers, and construction materials, as well as other types of manufacturing businesses have relocated in foreign countries (e.g., South Korea, Taiwan, Malaysia, the Philippines, Mexico, Venezuela). Although within the postindustrial nations, high-tech and specialty industries (such as plastics) are replacing the industrial products lost with new products or are creating substitute products, sufficient industrial capacity remains in the Western nations to support mobilization should war appear imminent. The industrial sectors of the Western postindustrial nations are well advanced technologically, especially those of the United States.

The high-tech specialization in the United States is creating new novel and innovative products that are robotic and plastic or the results of genetic engineering; all are improving the overall national economic scene as well as the quality of life of the general public. Further, these new industries increasingly are creating opportunities for additional industries and employment. Since the 1990s, U.S. public education, under Federal guidelines, has instituted new programs to accommodate the rapidly changing postindustrial U.S. society. Along with many new advanced courses related to high technology, there are courses in speed-learning of foreign languages and cultures designed to prepare graduates for both government and public employment. In 2005, as many as a third of the employees of most major U.S. industries work for their companies overseas for extended periods of time.

In general, since the late 1980s, the political attitude of both the U.S. Congress and the Administration increasingly has favored higher defense

expenditures (now over \$100 billion). Over the same period, Federal expenditures have also increased for space research and exploration as well as for science and technology and education, respectively. Social programs continue to be the highest budgeted item; such expenditures, however, have been on a gradual decline since mid-1990. By 2005, the United States has substantially increased its foreign aid programs and has been especially generous in economic aid to Third World countries striving to develop the skills needed to achieve industrial statehood. Additional U.S. dollars going to Third World countries are for military programs, most of which emphasize defensive military training using largely 20th century arms and early 21st century high-tech systems.

By the year 2005, many nations of the world, including newly industrialized nations, have achieved a new economic prosperity commensurate with general increases in their industrial productivity and trade. Some of these nations, however, harbor real or perceived fears of economic competitors and remain heavily armed with conventional weapons purchased from the arms dealers of the 20th century, while others continue to build their weapons inventories with early 21st century high-tech weapons purchases. Increasingly, Third World nations are producing light arms and ammunition as well as developing high-tech weapons industries under coproduction arrangements with some of the Western nations.

The number of nations possessing nuclear weapons in their arsenals in 2005 has increased by two over those known to have had such weapons in 1995. While the Soviet Union is continuing internal economic development programs that it began in the late 1980s, it has increased its expenditures in weapons programs and its military space activities significantly. Since the mid-1990s and stemming from U.S.-Soviet arms control meetings in the late 1980s, the Soviet Union and the United States have made periodic progress in the bilateral reduction of nuclear weapons, especially those confronting Eastern and Western Europe. The Soviet conventional strength, its remaining nuclear capabilities, and its military achievements in space, however, are a formidable threat to the United States and the free world. This Soviet military threat reinforces the traditional alertness of the United States to watch the worldwide adventuresome, political and economic activities of the Soviet Union.

A factor often overlooked as being important to the effectiveness of a nation's military posture is its societal or local community attitudes. During the past decade or so, the U.S. military increasingly has gained an acceptance within local U.S. communities that is beyond usual economic or political interests. New military installations have been created relative to demographic population shifts which assure the military of an adequate share of needed specialized civilian skills as well as transportation and resource accommodations. The positive military attitude toward the preservation of the local community's natural resources and toward environmental protection further contributes to the acceptance of the military's presence. This positive attitude, moreover, extends to the community in other ways also, e.g., use of nonspecific military training facilities in 2005 is available to local communities (beyond civil defense and disaster preparedness exercises) for civilian or joint civilian/military training in such nonmilitary programs as health, physical fitness and sports activities, and adult continuing education programs.

Because of the increasing imbalance of racial (whites, blacks) and ethnic (Hispanic, Asian, Black American, for example) groups in the U.S. population and the need to inculcate in all citizens the workings of democracy, citizenship, and constructive attitudes toward freedom, the U.S. Congress has passed an 18-month Universal Public Service (UPS) program for all citizens and noncitizen residents. The UPS program is currently in the implementation planning stage. UPS will assure citizenship for all, reduce welfare rolls, and by 2020, will provide a constant supply of workers and trainees for almost all Federal agencies including the military services.

In 2005, the U.S. defense posture is highly capable of reacting to any threat across the broad spectrum of war. The U.S. strategic defense has been bolstered by successive achievements during the past decade toward the accomplishment of a strategic space defense. Overall, however, U.S. defense strategy in 2005 relies less on a nuclear deterrent and more on conventional land, sea, and air forces under an unfolding strategic space umbrella. Since the turn of the century, the U.S. military services gradually have increased in numbers of personnel, weapons, and equipment commensurate to U.S. foreign economic and military assistance programs, which are extensive in 2005. U.S. forces overseas serve more as a deterrent to local conflicts, as U.S. soldier ambassadors and as world peacekeeping forces, than they serve in actual warfighting. Their overseas activities are nonthreatening and are oriented toward assisting host nations to maintain a peaceful climate while they grow into industrial statehood. The U.S. military services are organized under regional unified commanders-in-chief. In general, they are supported by single defense programs for logistics, communications, supplies, health, installation management, and other common functions.

The force structure of the BRAVO 2005 Army is about 30 percent light (rapidly deployable) and 40 percent heavy (not readily deployable). While the Army is equipped to fight with high-tech weapon systems primarily, it is still using some residual (and aging) 20th century conventional weapon systems, including tanks. The Active BRAVO 2005 Army is comprised of about 800 to 900 thousand troops and is reinforced by a large Reserve component of 1.2 to 1.4 million troops. Both the Active Army and the Reserve component are supported by a civilian force of 350 to 450 thousand specialized personnel which includes a variable average of 25 thousand contract personnel who are primarily engaged in combat training management and operations and other basic services. The 2005 reserve component can be 50 percent ready and deployable in 30 days. The large number of host nation military support agreements permit rapid deployment of U.S. forces worldwide and allow large amounts of equipment and supplies to be prepositioned and readily available in selected host nations.

Technology in 2005 readily assists transition from 20th century weapons and equipment to those of the 21st century. Training is especially advanced over that of the 20th century through the use of computerized simulators, robotics, simulations, and other electronic devices. Most training is with individual or unit simulators at collective, contract-operated training centers located regionally within the United States or at selected overseas host nations. Training, additionally, may be joint, or Army only, or at times combined with host-nation forces. Some exploratory training using military personnel on manned space platforms is currently in progress.

Planning for earthbound specialized installations also has been started to accommodate weapons technology advances for such systems as directed energy weapons, lasers, electronic magnetic pulse weapons, and electronic rail guns.

The firmly implanted trends of the BRAVO 2005 world suggest that over the next decade or so, the United States increasingly will become more heavily involved in all facets of international activity than ever before in its history as a nation. Not only will it be the economic mainstay of those Third World nations transitioning to industrial statehood but it likely will be the most advanced and influential postindustrial state, a titan among the nations of the world.

Section II. BRAVO 2020.

Internationally, the United States in the year 2020 is acknowledged by almost every nation as the foremost postindustrial state. It is also considered a colossus among the nations of the world. The United States is the world's model of national economic stability, growth, and leadership. Worldwide, the United States is a provider of benevolent economic and military assistance to selected countries for which overflight, port visitation, and basing rights as well as trading advantages are provided in return. Its international economic, sociopolitical, and moral influence is unsurpassed by any other postindustrial state. Most importantly, the United States is recognized by just about every nation as the most advanced military power of the world. Although the Soviet Union, an overall far less advanced industrial state than the United States, is showing more interest in internal economic development and less attention to its client states, it remains willing and capable of waging war if provoked.

During the past decade or so, the economies of almost every nation have grown significantly. The world economy by 2020 has become increasingly brisk and highly competitive. The postindustrial nations (the United States, Canada, Europe, Australia, and Japan), the leading markets of the 20th century in heavy industrial products, automobiles, and other manufactured products, are now the world leaders of high-tech products, services, information, and knowledge programs and systems. Former 20th century industrial nations along with newly industrialized nations (formerly Third World countries) are supplying the world with heavy industrial products and most other high-demand manufactured consumer products. Most nations of the world, except for the very poorest, are achieving a new economic prosperity that is expanding their horizons while, at the same time, altering their political and social infrastructures. The formal bilateral economic and political/military security agreements, as well as the ad hoc agreements signed by the industrializing countries and the United States a decade or so ago, have replaced almost all of the 20th century U.S. treaties and agreements.

The highly competitive world economy along with a broad transfer of technology have generated an increased frequency of trade wars and political and economic power competitions. Notwithstanding, most of the industrial states are trading off a new growth of nationalism for economic development and investment as a solution to financial and unemployment problems. Along with the comprehensive U.S. foreign aid programs and the generous economic aid of the U.S. Government and its business corporations over the past decade or so, the former Third World countries have developed the skills and expertise needed to achieve industrial statehood. This economic diplomacy, over the years, has continued to strengthen U.S. international political and economic influence, has ensured the availability of scarce mineral resources, and has guaranteed U.S. military presence and in-country rights overseas.

The achievements of science and the advances of high technology in Western postindustrial states by the year 2020 have offset the economic loss of heavy industries. Over the past three decades, the Western countries, the United States especially, increasingly have been importing steel, building and construction materials, and certain other heavy industrial and manufactured products. Until the development of plastic (polymer) munitions ordnance and

lightweight, high-impact armor plate in about 2010, the United States (for a short time only) imported ammunition for its military since U.S. arms manufacturers also left for foreign countries. Although the trade deficit increased early in the century, the introduction of new products and replacements developed by the specialty industries of the Western countries, especially those created in the high-polymer plastics industries, has reduced the deficit considerably. The continued efforts of science and technology, coupled with those of the specialty industries, provide the Western postindustrial states nearly full capability to support mobilization plans for most contingencies anticipated over the next decade or so.

National pride within the United States is as high as the economy is strong. Although the U.S. social and welfare program investment remains the foremost national budget expenditure, by 2020, new Federal social programs with cost and investment responsibility available for optional assumption by, or shared partnerships with, the state governments or with industry and the individual have reduced the social welfare budget expenditure to a point where the defense budget is almost equal to it. The defense budget in 2020 has increased to \$105 billion. These programs are followed in budget expenditures by national education, science and technology, and space research and exploration. Both the current Congress and Administration as well as the general public support extensive military programs. Almost all communities throughout the United States have accepted and approve of the military policy, which began in 2005, of sharing military facilities wherever and whenever possible. This program of sharing facilities has allowed an interchange between the military and the local communities that assists in resolving economic, resources, demographic, and attitude and value problems that are relevant to both military and civilian societies. The Universal Public Service (UPS) program, enacted in 2005, was fully implemented by 2015. Since that time, the UPS has provided a constant flow of qualified Americans through 18 months of training in an agency of the Federal Government. The most intensive training has been in the military. UPS has provided the military with qualified trainees, many of whom, after UPS training, have chosen to continue a career in the military. UPS has also bolstered the general economy and has helped to reduce national unemployment problems.

Most nations of the world, except the very poorest, have been highly armed by the new arms merchants of the industrial states. The number of nations with nuclear weapons and delivery systems in their arsenals has increased by two over those known to have had these weapons in the early years of the century. Despite some bilateral strategic nuclear arms reductions, which include mutually acceptable verification by the United States and the Soviet Union, continuing negotiations since the turn of the century have resulted in U.S. and Soviet strategic nuclear capabilities only being reduced to moderate to high levels when compared to 20th century capabilities.

The Soviet Union, dissatisfied to remain an industrial state while the United States is the foremost advanced postindustrial nation of the world, has made progress since the turn of the century in advancing its social and economic status. In the year 2020, it has embarked on its sixth economic and social modernization program, an ambitious plan of internal economic development. The Soviet Union is more adventuresome militarily than before the turn of the century, and continues to provide military arms and training

to its client states, while at the same time it is becoming increasingly more adventuresome economically worldwide. Moreover, the Soviet leadership not only has permitted an economic fusion of some East European states with Western Europe's common market, but also has become involved in somewhat speculative economic international trade ventures of its own that are interfering increasingly with U.S. trade relations. The European sector of the Soviet Union, however, remains highly capable of military intervention worldwide or of waging war despite the apparent disinclination of the preoccupied Soviet leadership to do so. The Soviet Army, however, continues to be the principal challenge to the U.S. military and one for which the United States must prepare.

The U.S. Army in BRAVO 2020 is organized principally as a standing Army of specialized, highly deployable active brigade-size fighting units. Although displacing a substantial number of Army personnel, technological achievements and innovations also have increased the overall requirement for training. Training programs for U.S. forces as well as foreign forces under military assistance and training programs are mostly accommodated by simulations and the use of simulators at CONUS and overseas installations and permit a large variety of joint/combined contingency plan rehearsals. During the year 2020, a 90-day major mobilization exercise is planned in Southwest Asia for the purpose of testing and comparing the reliability of the BRAVO 2020 military/contractor simulations training programs. Many training activities for the Army are performed by civilian contractors who use multi-environmental, functional training centers in CONUS and abroad. Training programs, as well as weapons and equipment development, stress environmental safeguards and the preservation of natural resources.

The Active BRAVO 2020 Army is a large component of about 800 to 900 thousand troops. Combat forces are 40 percent heavy, 50 percent medium, and 10 percent light. The Active force is supported by a Reserve component (ARNG and USAR) approaching 1.6 to 1.8 million troops and a highly technologically trained civilian component of about 200 to 250 thousand personnel. The total force is 60 percent high-tech. Additional support to the Army, especially the ARNG and USAR, is provided by the Universal Public Service program of 2005. In general, the quality of life for BRAVO 2020 Army personnel in all respects is equal to or better than that of their civilian counterpart.

The role of the BRAVO 2020 Army is to support a "big stick" deterrent strategy which complements the U.S. nuclear deterrent. Its force structure design is more than adequate for a broad range of contingencies from major war to small coalition warfare, to foreign internal defense or localized international unrest. Operationally, the BRAVO 2020 Army fully uses space-age technology and weapons under highly advanced stages of strategic defense. Twentieth century heavy equipment/weapons, e.g., tanks, are being displaced by light, easily transportable systems. Such systems are sustainable, automated, computerized or robotic, use near-earth and space transport and platforms, and are BRAVO 2020 Army force multipliers.

CHAPTER 6

ALTERNATIVE WORLD SCENARIOS: THE CHARLIE SCENARIOS

Section I. CHARLIE 2005.

Over the past several decades, many of the heavy industries, primarily of the Western nations (United States, Canada, and Western Europe), have relocated to foreign countries where economic conditions and available manpower appear to be more favorable. The loss of these industries has left the Western nations nearly unable to mobilize sufficiently to provide the production requirements of warfighting. Moreover, specialty industries, such as plastics, are only now approaching the capability to support mobilization programs.

The Western alliance, NATO, increasingly is becoming more of a shell than an effective military organization, largely due to apathy on the part of the European member nations (almost half of the European forces are at 60 percent strength and the rest are even less). Additionally, U.S./Soviet bilateral mutual troop and nuclear forces reductions which began in the late 1980s, along with increasing activities of European peace groups during the past decade, are believed by the Europeans to be eroding the alliance even further. Seizing the opportunity, an anti-American movement has resulted in a further reduction of U.S. forces in Western Europe. Now only about 60 percent of the U.S. forces remaining in Western Europe were there at the beginning of the century. These U.S. forces along with French military forces are believed by the Europeans to be the primary deterrent to war with the Warsaw Pact. The Western Europeans, rather than increasing their forces, are banking on serious economic overtures encouraging the East European nations to join the European Economic Community which the West Europeans believe will surmount any military threat.

During the past decade, the United States, one of the foremost postindustrial nations of the world, along with many of its businesses and industries, have continued to provide economic assistance to Third World countries for the modernization of their industrial infrastructure. U.S. military and economic assistance, however, has been decreasing over the past decade as U.S. alliances and agreements weaken. The economic growth of many of these countries by the year 2005 has surpassed that of any other period. A few of these countries, concerned with the adverse influence that modern industrialization, technology, and Western ideas are having on their national cultures, have resorted to aggressive acts of nationalism. They have nationalized several U.S. industries as well as those of a few other foreign nations, have expelled all foreigners and their military, and have reclaimed all U.S. military bases located in their territories. Several other newly industrialized Third World countries are threatening that they also are planning to nationalize foreign industries. The United States faces the relocation of its overseas forces, despite its efforts to halt this spread of nationalism, to alleviate Third World fears of irreversible cultural changes, or to retain a minimal U.S. military presence. The personnel in these forces

must be moved to other overseas bases that are in U.S. territories, returned to installations within the United States, transferred to Reserve status or discharged from the services.

Complicating the problem of restationing U.S. forces withdrawn from overseas have been growing trends in U.S. local communities to block any further increase in the number of installations and the number of troops at existing installations or the assignment of any new type of military weapons activities to these installations. This community attitude has grown from an increased concern for community environmental protection, the growth of local community populations around some military installations (cities are beginning to encircle them), and a growing community economic self-sufficiency brought about by the employment opportunities and increased tax base provided by expanding high-tech and information/services industries. The apparently antimilitary attitudes of the U.S. communities are not associated with any international organization nor is the local intent one of disloyalty. Public support for the military actually is high; these local communities just do not want the military in their backyards. Similar movements against U.S. overseas and NATO bases, however, have been occurring in Western Europe (as well as in Turkey and Greece), the Philippines, and South Korea over the past decade or so; those movements have been linked increasingly to foreign sources for support.

The U.S. political leadership of the Administration and the Congress faced with these problems is mindful of the need to maintain a strong national defense posture to counter any military threat to U.S. interests. Since the turn of the century, the Administration has convinced the Congress to provide substantial multiyear defense budgets that have supported the initiation of comprehensive long-range defense plans. These plans redesign and strengthen the U.S. military posture through investments in the research and development of advanced technological military systems and the field testing of new 21st century weapons. The long-range plans include the use of space to support basic military systems for earthbound combat operations, such as communication, navigation, and logistics (prototype logistic and staging platforms are already in place). The Administration also has introduced as part of its long-range planning a comprehensive program for a Federal/State financed Universal Public Service (UPS) program that, once operational, will provide trained personnel to almost all Federal and State government agencies, including the military. Overall, these long-range plans will reestablish and sustain the United States as the leading world political, economic, and military power, despite the weakening effects of the loss of overseas bases, should such Third World trends continue in the coming years.

The immediate effects of the defense plans have created a smaller, more effective military force in 2005 whose capabilities are enhanced by available technological force multipliers, such as advanced weapons, mobility, and logistical systems. These systems, new generation high-tech land weapons, and in-place prototype sea, air, and space platforms (bases) will enable the military to react defensively to the conflict contingencies envisioned in the near to long-range future. These contingencies, for the most part, are at the low to mid intensity level of the spectrum of warfare. Over the next decade or so, the most likely conflicts to occur would be unconventional and insurgencies; less likely would be conventional and high-tech conflicts; and

the least likely would be tactical or strategic nuclear conflicts. These estimates are based on the continued proliferation of conventional, high-tech, and nuclear weapons during the latter years of the 20th century and the early years of the 21st century.

Most of the nations of the world, except the very poorest, have been armed by 20th century arms merchants with that era's conventional weapons; some, additionally, have acquired late 20th/early 21st century high-tech weapons and missiles; and others have added nuclear weapons to their arsenals. The number of nations possessing nuclear weapons and delivery systems in 2005 has increased by a third over those known to have had such weapons a decade ago.

The Soviet Union, although not actively involved in any conflict in 2005, continues to support its client states but to a lesser extent than it did before commencement of mutual nuclear arms reductions with the United States in the late 1980s. Increasingly, since that time, the primary interest of the Soviet leadership has been national economic and social development. Additionally, the Soviet leadership is demonstrating a cooperative attitude toward maintaining the incremental bilateral agreements with the United States, especially relating to inspection of former nuclear sites and verification of dismantled and destroyed weapons and warheads. Although less inclined toward military aggressiveness since the mid-1990s, the Soviet Union still retains a conventional military capability which, although partially withdrawn from Eastern Europe and contained in the Soviet Union, is not perceived as a threat by Western Europe.

U.S. military leadership in 2005 is keenly aware of the existing Soviet warfighting capabilities and the conflict potential of a highly competitive economic world. Moreover, it realizes the need to maintain a strong U.S. military posture and believes that the restructuring of each of the services commensurate to the limitations imposed in the 2005 environment, along with the development of new technology- and space-oriented military strategy, will provide a U.S. warfighting capability that will be an effective worldwide deterrent to any renewed Soviet aggressiveness.

The U.S. force structure in 2005 continues as three separate service departments, although logistics, personnel, and communications for each are now under the single control and management of the Department of Defense (DOD). Troop transport, in general, is largely by civilian contract as are base facility support and medical health care and services. The arrangement assists the services in being more reactive to worldwide threats to U.S. interests and to fulfill their primary mission, defending the United States. When called upon, U.S. forces provide defensive assistance to former U.S. allies and friendly nations at a force level commensurate to the threat and with an appropriate mix of the services to resolve the threat issue or terminate a conflict as quickly as possible. The force structure and end strength of the Army, whose mission is ground defense, is designed to accommodate this strategy of measured force, i.e., a force tailored to the threat and type of conflict anticipated.

The Active component (AC) of the Army in CHARLIE 2005 is about 30 percent light (man intensive and rapidly deployable) and the Reserve component (RC) is about 40 percent heavy (equipment intensive and not as readily deployable).

This force structure has evolved as circumstances have forced the United States to withdraw about 40 percent of its overseas forces. Additionally, as a result of this situation, the U.S. Congress has amended Title 32 and the RC now combines the National Guard and the Army Reserve into a single component. This 2005 RC is organized, equipped, and trained in the same manner as the Active Army. The end strength of the AC in 2005 is about 350 to 450 thousand troops and the RC is about 1.1 to 1.2 million. The RC is capable of rapid mobilization equally from home stations and regional training centers. The supporting civilian component is about 150 to 250 thousand personnel who are highly trained and integrated with the AC and RC, and are selectively required by contract to stay in place in the event of war.

To accommodate the national security needs of the postindustrial United States, manage available manpower, and furnish appropriate and affordable 21st century training, the 2005 Administration has introduced a National Defense Force (NDF) plan, which when enacted by the Congress and implemented by DOD will produce a one uniformed service in the United States. The NDF is expected to be fully operational within the next decade or so.

The CHARLIE 2005 Army is organized, equipped, and trained as small, readily mobile fighting units that are stationed increasingly in sparsely populated areas in the United States. The Army is organized to fight in a configuration that stresses self-containment and self-sustainment under hazardous conditions for 40 days duration before unit replacement, while individual replacement is during combat. Resupply is mostly by air or sea (surface and subsurface) logistic units, and eventually from space (platforms or bases) when development is complete. The Army is equipped with a mix of late 20th century (about 40 percent) and early 21st century (about 60 percent) materiel, weapons, and ancillary systems. Most of the 20th century weapon systems, such as the tank, are obsolescent and are being phased out of inventory. Where feasible, about 90 percent of all new equipment and systems are computerized as well as hardened and shielded. Increasingly, routine, boring, and hazardous tasks are robotized (about 75 percent) also, including ground transportation, surveillance, and decontamination.

Both men and women of the Army increasingly are trained for combat operations by simulation and simulators under civilian contracts which use especially designed computerized facilities that are space savers (e.g., half above/half below ground level) at regional Army installation training centers. Additionally, both the AC and RC of the Army are involved in exploratory training in the use of the prototype air, sea, and space logistic and staging area platforms. The Army RC is organized and equipped the same as the Army AC and both train together at the regional training centers. Although available land for field training is becoming increasingly scarce as local U.S. communities become more critical of Army environmental pollution, a few stateside locations away from dense populations remain available. A few friendly overseas locations in countries where U.S. bases still exist also provide possible additional land where field training can be conducted.

Section II. CHARLIE 2020.

The United States over the past decade and a half has been faced with the withdrawal of its military forces from its overseas bases, especially those in the industrializing countries (formerly Third World countries) as well as many of the weakened NATO countries. Also during this period, with the generous help of U.S. economic aid and U.S. private corporation advice and financial assistance, the international status of many of the Third World countries was gradually transformed into modern industrial nations and many, additionally, had adopted more representative, mostly parliamentary, forms of government more compatible with capitalism and the economic growth they were experiencing. Believing that, since the beginning of the century, the influx of Western technology, people, and ideas were changing their societies and obscuring their national identities, most of these nations are seeking refuge in a revived nationalism as others had in 2005.

Increasingly, over the past decade or so, these countries were becoming more intimidated by and apprehensive of the technological changes that accompany industrialization; they also were becoming more protective of their culture and their country as they turned to nationalism. Regardless of treaties, military agreements, or other arrangements with the United States, these nations, which had previously welcomed American presence, have nationalized foreign industries, expelled U.S. nationals and other Westerners, denied overflight and port visitation rights, and reclaimed all U.S. bases on their territories. This rise of neonationalism worldwide has suppressed U.S. opportunities for international political and economic influence and is forcing the United States to rely on its stockpiles of strategic resources.

The United States in the year 2020 is the foremost postindustrial nation of the world. Over the past several decades, it has advocated, supported, and maintained a strong military defense; its investments in technologically advanced military systems, especially those using the fourth dimension of space, have surpassed any previous military investments. Such systems have reduced the military requirement for massive land forces and allowed military strategists to devise technology- and space-oriented strategies that will accommodate a 21st century U.S. military force as well as counter traditional strategies of land warfare. Such innovativeness is essential to the United States, especially its military, since nearly all U.S. heavy industries, including arms manufacturers, have relocated to foreign industrial nations. This relocation of heavy industry has occurred in almost all other Western postindustrial nations as well as Japan. This situation a decade or so ago had left the United States and the Western nations in a situation where their postindustrial infrastructures appeared unable to provide military equipment or weapons in the event of a need for industrial mobilization. By the year 2020, the U.S. high-polymer plastics industry has perfected precision designed lightweight munitions ordnance and armor plate which can be produced in the quantities needed for military purposes.

During the past 15 years, the increasing migration of high-tech, service, and information workers to the city areas has brought these cities closer to the creation of east/west and north/south megalopolises. More communities are expanding adjacent to military installations in 2020 and more demands are being made for them to close and find other locations. Forces returning from

overseas have been deactivated and units and individuals have been assigned to the reserves to reduce the military population around the most congested cities.

The long-range defense plans and the substantial multiyear defense budgets approved by the 2005 Congress have assisted the Department of Defense (DOD) in acquiring the necessary advanced technological equipment and weapons needed to maintain readiness with a minimum of combat forces and develop space systems to support earthbound combat operations. Additionally, of the prototype space platforms developed and in place in 2005, the logistic platform is operational but the troop staging platform is useful only for small special operations activities. Between the years of 2005 and 2020, the Federal/State financed Universal Public Service (UPS) program has been passed by the Congress and approved by two thirds of the state governments, and is inducting trainees for 18 months of training in almost all agencies of Federal and state governments.

Almost all of the nations of the world, except the very poorest, have been armed with 20th century conventional weapons and ancillary systems and early 21st century high-tech weapons. A new generation of arms merchants since the turn of the century have continued the sale of arms and have increased the number of nations possessing nuclear weapons and delivery means by 25 percent over the number known to have had them in 2005. Most of the industrial nations of the world, although achieving moderate to high economic growth, increasingly are unable to cope with the highly competitive challenges of the world economy. Their possession of nuclear weapons is a growing concern of the United States and the Soviet Union.

The Soviet Union is continuing with its programs of economic and social development throughout the entire Republic and is in its fourth 5-year plan since the turn of the century. The Soviet leaders have continued their sincere cooperation with the United States in nuclear arms reductions and in inspection and verification, as they have since 2005. Moreover, they have maintained a peaceful attitude toward Western Europe and have withdrawn almost all of their forces from Eastern Europe after 2005. Although the Soviet Union still retains a conventional military capability, it does not pose a threat to Western Europe. While the Soviet leadership is showing less interest in and reduced support for client states, it has also traded its 20th century adventuresome military interests for national economic pursuits.

The U.S. Army in the CHARLIE 2020 environment is organized as an arm of the National Defense Forces (NDF) which include the other services. The NDF is comprised of small, self-contained, highly mobile, light fighting units. Active NDF have dual or multiple operational capabilities, e.g., air or space and land or sea; or space, air and land or sea, and are rapidly deployable from regional centers located away from dense populations. They are essentially 100 percent high-tech and are equipped with high-tech throwaway (biodegradable) combat weapons, communications, and transport systems many of which are robotic. Resupply is mostly by air and space logistic units. Training, individual and by unit, is predominantly by computer simulation and simulators that are linked to or are at local or regional centers. The Active force is supported by a large single Reserve component, (the National Guard and Reserve combined) which is organized, equipped, and trained identically to and combined with the active NDF at regional training centers.

The Active CHARLIE 2020 Army is a small component of the NDF with about 200 to 250 thousand troops, 40 percent of which are organized in light, self-contained, self-sustaining, rapidly deployable combat units. Additionally, Army combat forces are 10 percent heavy and 50 percent medium. The Active Army is supported by a larger, single Reserve component with about 1.2 to 1.5 million troops, which is organized the same as the Active component. The CHARLIE 2020 Army is supported by a highly technically trained civilian force of about 100-150 thousand that is integrated within both the Active and Reserve component and contractually dedicated to service during war. A mandatory national public service program provides a rotation of combat trained men and women who are selectively offered career opportunities after training. Most services (e.g., installation management, training, maintenance) are conducted under public contracts. The Army's budget is about \$120 billion. In general, the quality of life for the Army component and other NDF personnel is modernized but austere (e.g., ship-board style living). The role of the CHARLIE 2020 Army component, like that of the NDF as a whole, is defensive and reactionary to serious threats to U.S. national security and interests and complements a residual U.S. nuclear deterrent. The NDF are operationally trained for a range of contingencies worldwide with a capability to fight a conventional war strategy including chemical/biological warfare. NDF are deployed from strategic locations in space, sea (surface and subsurface), and air or land from the United States.

CHAPTER 7

ALTERNATIVE WORLD SCENARIOS: THE DELTA SCENARIOS

Section I. DELTA 2005.

In the year 2005, the United States is one of the foremost postindustrial nations of the new century. It shares this position with Japan, Europe, Canada, and Australia. The U.S. economic infrastructure at the start of the 21st century is predominantly science based and technology oriented. Its economy supports information, services, and knowledge industries that employ about 60 percent of the U.S. population. Because the United States is recognized by other nations as a world economic leader, its foreign relations are good with almost every nation whether it has formal agreements or not. This general worldwide acceptance has strengthened U.S. political, economic, and military influence and preserved U.S. military presence in almost all corners of the globe.

By and large, the United States is respected worldwide for its willingness to provide economic assistance (monetary and advisory) and information exchange (management and technology) to other nations, especially Third World nations that are transitioning from developing countries to modern industrialized nations. It is also respected for the stature of its military, which most nations believe is well trained, armed with the most advanced weapons and technology of the 21st century, and highly capable of rapid and efficient warfighting operations. Its presence is quite visible around the world and provides an umbrella of protection for many small nations. These nations in return ensure that scarce resources are available to the United States and provide port visitation and basing rights for U.S. forces. The U.S. military, despite all outward appearances, is making difficult decisions, however, within the United States regarding its future as a result of national trends that have developed in the late 20th century.

Over the past several decades, as many as 70 percent of U.S. heavy industries, such as steel, chemicals, and arms manufacturers, and about 45 percent of the lighter U.S. manufacturing industries, e.g., automobiles, appliances, and building construction and fabrication supplies, have relocated in foreign nations. Most of these industries have remained under American ownership or have arranged coproduction agreements with or resale directly to foreign business concerns. Notwithstanding the loss of these industries, almost all sectors of the U.S. economy are flourishing (at about 2-2.5 percent growth per year) as are the economies of almost all other nations of the world. A comparable relocation of heavy industries has taken place in other Western postindustrial countries (Canada, Europe, and Australia) as well as in Japan. Western nations in 2005 still remain dependent on steel armament for some 20th century military equipment, e.g., armored vehicles, and only during the past decade have the U.S. plastics (high-polymers) industries perfected ordnance and lightweight, high-impact armor plate. The industrial capacity of Western nations to support mobilization therefore is marginal, at best. Within about 5 years the U.S. military will be able to field the new plastic ordnance and armored equipment.

The U.S. economy in 2005 also supports light fabricating enterprises that produce automated and robotic products, electronic and optical specialties, and computer hardware and software. The fabricating industries employ about 10 percent of the U.S. population. Two other important industries of the U.S. postindustrial society are the plastics and the techno-agricultural industries, which employ about 10 and 5 percent of the population, respectively. In addition to their use in ordnance and armor plate, lightweight plastics increasingly are replacing traditional structural building and plating materials. The techno-agricultural industries produce a significant portion of the nation's food supply and, essentially, have replaced about 40 percent of the large farms of the past. They require less than a third of the land space formerly needed for late 20th century farming. About a third of the former farming land is occupied by new housing developments and high-tech industries; the remainder is now used for pasture lands, timber, and national parks.

Increasingly over the past two decades or so, there has been a growing public reaction by local U.S. communities, especially those that are contiguous to or within 25 miles of military installations, to the U.S. military's inability to cope with community environmental protection standards. The public's response has been directed further against the military's position that state environmental regulations are encroaching upon military installations and constraining the military's readiness in support of national defense. Reaction has been aimed at the military's lack of remedies for pollution of the air and water table presumed to be caused by military systems and procedures (e.g., disposal of toxic wastes, transport of potentially toxic and hazardous substances, and noise). Moreover, response is also directed toward a presumed disregard of environmental conservation (e.g., wasteful consumption of natural resources, especially water). Although the public reaction by 2005 has not stirred congressional response, several states have enacted environmental protection legislation that prohibits or severely restricts specific military activities such as the disposal of used petroleum, spent nuclear wastes, and the movement of obsolete chemical, radiological, and nuclear weapons. This has resulted in the closure of several military bases and their literal reduction to fenced in and guarded toxic waste dumps. Additionally, during the late 1990s, public reaction to noise generation blocked the development of several artillery ranges and armored vehicle training installations.

Concurrent with this increasing and apparently antimilitary public attitude has been the growing economic independence of many local communities and the rising affluence of individuals; neither of which in 2005 needs the economic support of military installations. Such economic support is now provided by high-tech services and information industries that the local communities and states have encouraged over the past decade or so to locate in their areas. The employment and high wage opportunities offered by these industries have created population shifts and migrations which, in turn, have created new housing developments and communities that gradually will encircle adjacent military installations. They are the beginning of potential east-west, north-south megalopolises. Further complicating the problems for the nearby military installations are the growing difficulties they are facing in competing for and attracting the high quality civilian personnel whose skills both the military and industries need.

Military manpower requirements are made more difficult by the national population age and ethnic distribution. In 2005, the average population age in the United States is about 38 years. In general, there are fewer 18-24 year old youths eligible for military service. The ethnic distribution in the United States is approaching about 28 percent blacks, Hispanics, and Asians. More than 50 percent of the available 18-24 years of age males and females are in this group. This population age and ethnic distribution can be expected to continue to rise over the next decade or so. Moreover, these groups increasingly will become more involved and influential in all aspects of national life. The U.S. national political leadership (the Administration and a small majority of the Congress), aware of the increasing social and economic problems of these groups over the past decade or so, has increasingly sponsored national social welfare programs and investments, especially in housing, health, and education, to raise their standard of living and increase their contribution and participation in the nation's postindustrial economy. Following the social welfare investment in the national budget are space, science and technology, and defense programs. Although national security and defense are budgeted lower than in past political administrations, the U.S. defense budget remains one of the highest per capita investments of any comparable postindustrial nation.

Almost all nations of the world, except the very poorest of the Third World nations, have invested in a military force armed with 20th century conventional weapons. Comparable to their perception of threats to their nation, some have small to moderate size military forces, while others have moderate to large forces and are armed additionally with more modern high-tech weapons of the late 20th and early 21st century. By 2005, the number of nations possessing nuclear weapons and delivery means has increased by 20 percent over the preceding decade. Both the United States and the Soviet Union, who have been involved in nuclear arms reductions since the late 1980s, are showing concern over this increase in nuclear proliferation.

The Soviet Union in 2005 is involved in a third 5-year program to improve its national economy and raise the national standard of living. Although the Soviet leaders still support client states, they are less involved in sponsoring new communist regimes than they were before the turn of the century, especially if doing so involves the use of a large military force and sizeable monetary expenditures. Moreover, they are more adventuresome in economic innovativeness and experimentation than they are in military undertakings. The Soviet Union still retains a conventional capability but that is not perceived as a serious threat to Western Europe, which still depends on the presence of U.S. forces and their linkage to U.S. nuclear forces as a primary deterrent. An assessment of Soviet strategy by the Western nations suggests that the Soviet leadership is attempting to reduce international tensions for whatever time is needed for the Soviet economy and society to acquire postindustrial statehood.

The combined impact of world and U.S. domestic trends and events on the U.S. military over the past decade or so increasingly has encouraged the Department of Defense (DOD) to reevaluate U.S. military organization, force structure, and, especially, where the military will be stationed within the United States. The mission of U.S. forces in 2005 continues to be the defense of the United States, its interests and its allies. The defense posture for

the next decade will continue to be highly capable of reacting to any threat across the spectrum of warfare. U.S. defense strategy in 2005, however, is relying more heavily on conventional (including high-tech) land, sea, and air for deterrence than it is on a nuclear strategy of deterrence since the start of bilateral (U.S./Soviet) nuclear arms reductions in the late 1980s.

The U.S. force structure has shifted from emphasis on separate services to joint/unified commands. The total force is about 70 percent heavy (i.e., equipment intensive and not easily deployable) and about 30 percent light (i.e., man intensive and easily deployable) and includes specialized land, sea, air, and space elements. The Reserve components are assigned a roundout (50 percent) mission for all elements. Logistics, communications, personnel, transportation, training, and installation facilities management and operations are all under DOD control and most of these have been placed under civilian contract arrangements.

The end strength of the 2005 Army Active component (AC) is about 700 to 800 thousand troops; the Reserve component (RC) strength is about 1.2 to 1.3 million (60 percent Army Reserve and 40 percent Army National Guard); and the civilian support is 350 to 400 thousand specially trained civilians. Most of the training for the AC and RC is under civilian contract, including services and facilities, and is conducted both within the United States (60 percent) and overseas (40 percent). About 70 percent of the RC train on a rotational basis overseas with the Active forces, and mobilization is mostly from regional U.S. training centers.

Simulation is used increasingly in training and new innovative training simulators are used at regional training and multipurpose centers for concurrent AC and RC training located in the United States at low-density population areas. These centers replace the installations that have been closed to accommodate environmental protection legislation. The Reserve forces not only train with the Active forces but also are manned, equipped, and structured similarly to them. Moreover, despite only a meager budgetary investment in advanced technological systems, e.g., robotic equipment and high-tech weapons, new innovative technological equipment and the doctrine and strategy for their use are equally shared between the Active and Reserve forces. Because of the difficulty in manning the Army, AC and RC, with qualified men and women in the 2005 demographic environment, DOD has considered but ruled out for the time being the need for compulsory national service based on marginally acceptable end strengths and the perceived ability of the Army to fulfill its mission. At its current strength, the Army is capable of performing its mission of ground defense and, further, is nearly capable of conducting offensive operations across the broad spectrum of warfare since the requirement for tactical nuclear operations has been reduced.

Section II. DELTA 2020.

Over the past decade or so, U.S. communities increasingly have rejected the presence of military bases contiguous to or within 25 to 50 miles of major cities. East-west and north-south patterns of urban sprawl throughout the nation are beginning to form vast megalopolises that are encircling military bases and installations.

Many U.S. communities vehemently oppose any increased installation investments made to accommodate strange and new weapon systems that might pollute their environment and consume their resources. Since 2005, additional states have enacted environmental protection legislation that is so stringent that many military installations within those states have been forced to close. Recently, organized groups of citizens condoned by state governments have blocked the addition to and creation of installations for new military systems, troops, and training programs that they believe would increase the risk of their community to additional environmental pollution by military activities or as a target of enemy attack in the event of war. Most U.S. communities are economically viable and have little need for the economic support provided by military bases. Politically, most communities are represented by an older population and one that is approaching 40 percent blacks, Hispanics, and Asians combined. On the average, the same representation exists in state and federal governmental bodies. The political, economic, and social influence and impact of this near majority on U.S. national and international affairs are substantial. This impact affects U.S. society in general, but is especially reflected in the U.S. national political leaders who advocate comprehensive national social welfare programs and investments. These Federal programs are followed by investments in education, space, science and technology, and defense programs. The Army's budget is about \$85 billion.

The United States is the leading postindustrial nation of the world. A very large percentage of Americans are employed in the services, information, and knowledge sectors of the U.S. economy. Heavy U.S. industries, such as steel and chemicals, as well as most manufacturers of automobiles, appliances, and building supplies have relocated to foreign nations from which the United States imports such needs. Specialty industries, such as plastics (polymers) and high technology industries, support the U.S. economy which is flourishing. A comparable situation exists in the other Western postindustrial nations of Canada, Europe, Australia, and Japan. Most Western strategic analysts believed at the turn of the century that the Western postindustrial infrastructures, along with their specialty industries, lacked the capacity to support national mobilization plans in the event of a major war. The plastics industry has proved this wrong, since a decade or so ago it developed plastic ordnance and lightweight, high-impact armor plate and has recently developed building construction beams.

Worldwide, over the past decade, many nations have traded nationalism, which had been growing since the turn of the century, for economic security and development. This has strengthened U.S. international political, economic and military influence and has preserved U.S. military presence, bases and installations, overseas. These countries also welcomed American businesses

and their managerial expertise. With this arrangement, these nations not only receive financial assistance from the United States, but also information, services and training, and most importantly, a security umbrella.

Most nations of the world, except the very poorest, remain heavily armed with conventional weapons. Others, additionally, are armed with more modern high-tech weapons systems, and the number of nations with nuclear weapons and delivery systems has increased by two since the year 2005. The Soviet Union, beset with constant economic setbacks, is bent on national economic catch up throughout its vast territory to enable it to achieve postindustrial status and compete with the United States. It has therefore become more adventuresome economically than militarily. Militarily, the Soviet leadership continues to train and provide arms to its client states, while at the same time increasingly involves them in economic experimentation. Although Soviet conventional warfighting capabilities remain substantial in 2020, they do not pose an immediate threat to Western Europe since Soviet interests, for the time being, have turned toward internal economic development.

U.S. defense programs in the DELTA 2020 world are austere. The economic benefits and military security that are provided to host nations by U.S. installations overseas have strengthened U.S. international political, economic, and military influence. These overseas installations accommodate U.S. military training and offer opportunities for the acquisition of additional land to expand training for U.S. reserve forces as well as U.S. military assistance programs.

The DELTA 2020 Army is organized as a component of a single, unified defense force (UDF) which includes the other Services in a mix of generalists and specialists. Light (easily deployable) Army divisions complement heavy (less deployable) Army divisions at a ratio of about 40:60 for both the Active and Reserve components of the Army. The DELTA 2020 Army component has increased the activities performed by contractors (e.g., administration, medical and personal services, pilots). This has made more personnel available for the fighting force, while at the same time, has decreased the deployable combat logistic tail and sustaining base. The Active Army component is 75 percent high-tech and is equipped with robotic systems, modern weaponry and technology, and lightweight plastic (polymers) transport and fighting vehicles appropriate for land, sea, and air combat operations. The Army National Guard and Army Reserve work closely with the Active Army. The Reserve component is manned and equipped similarly to, and trains constantly with the Active Army component within the UDF operational training programs. The UDF training programs support a total force concept where, within the United States, the UDF trains together as one entity at regional centers. The UDF is manned by highly educated, goal-oriented men and women of diverse ethnic origins from an information and service oriented postindustrial society. A draft may be needed to provide the required UDF staffing.

The Active DELTA 2020 Army component of the UDF is a large component of about 700-800 thousand troops. The Army combat forces are 60 percent heavy, 20 percent medium, and 20 percent light. They are supported by a larger Reserve component of about 900 thousand to 1.2 million National Guardsmen and Army reservists who wear the UDF uniform. Civilian support to the Active Army and Reserve component includes about 250-300 thousand highly-trained

personnel. The quality of life ranges from spartan during training to comparability with civilian pay and benefits after training. The primary role of the DELTA 2020 Army component, like that of the UDF, is defensive but it is fully capable of offensive operations when needed. The UDF complements the U.S. nuclear deterrent and is operationally trained to fight a variety of conventional contingencies.

SELECTED BIBLIOGRAPHY

- Adamek, Joseph. "Centrally Planned Economics in Europe: Economic Overview 1985." The Conference Board, 1985.
- American Council of Life Insurance. "Collapse of the Global Financial Superstructure." Trend Analysis Program (TAP 23), Summer Issue, 1983.
- _____. "New Immigrants, New Minorities" by Leon F. Bouvier. Trend Analysis Program, July 1986.
- Becker, Harold S. "A Tool of Growing Importance to Policy Analysts in Government and Industry." Technological Forecasting and Social Change, Vol. 23, 1983, pp. 95-120.
- Bell, Daniel. The Coming of the Post-Industrial Society: A Venture in Social Forecasting. New York: Basic Books, Inc., 1973.
- _____. The End of Ideology. New York: Crowell-Collier, 1961.
- Bouvier, Leon F. "Planet Earth 1984-2034: A Demographic Vision." Population Bulletin, Vol. 39, No. 1, Washington: Population Reference Bureau, Inc., 1984.
- Bright, James R. Practical Technology Forecasting. Austin, TX: Technology Futures, Inc., 1978.
- Cornish, Edward, ed. Communications Tomorrow: The Coming of the Information Society. Bethesda, MD: World Future Society, 1982. Pp. 84-91: "The Information Society: The Path to Post-Industrial Growth," by Graham T. T. Molitor.
- Crittenden, Ann. "I.M.F. Aid Up Sharply; Focus on Poorer Nations." The New York Times, May 13, 1980, p. D-8.
- Dizard, Wilson P., Jr. The Coming of the Information Age: An Overview of Technology, Economics, and Politics. 2d Edition. New York: Longman Inc., 1985.
- Enzer, Selwyn. "Exploring Long-Term Business Climates and Strategies with INTERAX." Futures, Vol. 13, 1981, pp. 468-482.
- Fowles, Jib, ed. Handbook of Futures Research. Westport, CN: Greenwood Press, 1979. Pp. 225-247: "Scenarios," by Ian H. Wilson.
- Gastil, Raymond D. "The Comparative Survey of Freedom 1987." Freedom at Issue, No. 89, January-February 1987, pp. 3-16.
- Gever, John, and others. Beyond Oil: The Threat to Food and Fuel in the Coming Decades. Cambridge, MA: Ballinger Publishing Company, 1986.

- Grimmett, Richard F. Trends in Conventional Arms Transfers to the Third World by Major Suppliers, 1975-1986. Washington: Congressional Research Service, The Library of Congress, May 1986.
- Hall, Lynne. "Environmental Assessment." Preworkshop submission in Public Issue Early Warning Systems: Legislation and Institutional Alternatives. Hearing and Workshop by the Subcommittee on Oversight and Investigations and the Subcommittee on Energy Conservation and Power and the Committee on Energy and Commerce, U.S. House of Representatives. 97th Cong., 2d sess., 1982. Washington: U.S. Government Printing Office, October 1982. Pp. 235-266.
- Haub, Carl and Medeiros Kent, Mary. 1987 World Population Data Sheet. Washington: Population Reference Bureau, Inc., 1987.
- Huss, William R., and Honton, E. J. "Alternative Methods for Developing Business Scenarios." Technological Forecasting and Social Change, Vol. 31, 1987, pp 219-238.
- Jones, Thomas E. Options for the Future: A Comparative Analysis of Policy-Oriented Forecasts. New York: Praeger Publishers, 1980.
- Kahn, Herman. World Economic Development: 1979 and Beyond. Boulder, CO: Westview Press, 1979.
- _____, and others. The Next 200 Years: A Scenario for America and the World. New York: William Morrow and Company, Inc., 1976.
- _____, and Wiener, Anthony J. The Year 2000: A Framework for Speculation on the Next Thirty-Three Years. New York: MacMillan, 1967.
- Longo, Joseph Peter, and McGrady, Patsy M. Methodology Catalog: An Aid to Intelligence Analysts and Forecasters. Washington: U.S. Defense Intelligence Agency, December 1983.
- Manfried, Arthur F., and others. Ballistic Missile Proliferation Potential in the Third World. Washington: Congressional Research Service, The Library of Congress, April 1986.
- Margiotta, Franklin D., and Sanders, Ralph, eds. Technology, Strategy and National Security. Washington: National Defense University Press, 1985. Pp. 105-138: "The US Technology Base: Problems and Prospects," by Jaques Gansler.
- Masuda, Joneji. The Information Society As Post-Industrial Society. Washington: World Future Society, 1981.
- Morrison, James L., Renfro, William L., and Boucher, Wayne I., eds. Applying Methods and Techniques of Futures Research. New Directions for Institutional Research, No. 39. San Francisco: Jossey-Bass Inc., 1983. Pp. 51-68: "Multiple Scenario Analysis: Introducing Uncertainty into the Planning Process," by Richard B. Heydinger and Rene D. Zentner.

Murray, Robert J., and others. Harvard University Seminar on U.S. Army Long-Range Stationing Study. Cambridge, MA.: John F. Kennedy School of Government, Harvard University, October 8-9, 1987. (Organized and conducted by Trinity International, Inc., a subcontractor to CACI, Inc-Federal, under contractor number MDA-903-87-C-0639, in support of the U.S. Army Long-Range Stationing Study.)

Renfro, William L. "Future Histories." The Futurist, Vol. 21, No. 2, March-April 1987, pp. 38-41.

Schnaars, Steven P. "How to Develop and Use Scenarios." Long Range Planning, Vol. 20, No. 1, February 1987, pp. 105-114.

Taylor, Charles W. A Concept of A Future Force, Carlisle Barracks, PA: U.S. Army War College, Strategic Studies Institute, November 2, 1981.

_____. Pilot Delphi Project, Part I: Project Summary; Part II: Project Event Forecast Analysis and Technical Report. Carlisle Barracks, PA: U.S. Army War College, Strategic Studies Institute, December 15, 1985.

_____. The Relationship of Forecasting to Long-Range Planning. Carlisle Barracks, PA: U.S. Army War College, Strategic Studies Institute, November 15, 1982.

_____. A World 2010: A Decline of Superpower Influence. Carlisle Barracks, PA: U.S. Army War College, Strategic Studies Institute, July 10, 1986.

Vanston, John H., and others. "Alternate Scenario Planning." Technological Forecasting and Social Change, Vol. 10, No. 2, 1977, pp. 159-180.

APPENDIX A

EXPANDED THEMES OF
ALPHA 2020: U.S. ISOLATIONIST

ALPHA 2020: U.S. ISOLATIONIST

During the past several decades, most of the nations of the world have experienced a period of rising economic growth that has been increasingly challenged by an invigorated, but highly competitive, world economy. Most nations of the world, except the very poorest, are armed with 20th and 21st century conventional weapons and others with high-tech conventional weapons and systems as well. Nations with nuclear weapons and delivery systems in their arsenals have significantly increased in number since the end of the century.

The economic progress that most nations have made, along with the absence of any major wars over the past 30 years or so, have outbalanced an armed and militarily competitive world in furtherance of a peaceful but economically competitive world. The United States is a prospering postindustrial state while the Soviet Union is an industrial state striving to increase its economic growth. Currently, Soviet interests are turned toward internal economic and social development. It remains a formidable military power although it is becoming more adventuresome and unpredictable economically rather than militarily.

The United States, one of the foremost economic postindustrial countries of the world, has turned increasingly toward expansion of its social welfare programs over the past two decades. The U.S. economy in 2020 is skewed decidedly toward a social investment economy which comprises a disproportionate part of its national budget. Social programs are followed by national education, space, defense, and science and technology programs. This same trend, however, is occurring in all other free-world nations as well.

Moreover, most of the heavy industries, those that made nations great during the past two centuries, essentially have disappeared from the postindustrial states of the United States, Canada, Europe, Australia, and Japan and have relocated in the industrial states in South, Southeast, and Southwest Asia; China; and South America. Most industries of the postindustrial nations are high-tech oriented and are supported by specialty industries. Heavy industrial needs of these nations are imported competitively in the world market. This situation has brought to the forefront a serious realization that the Western postindustrial infrastructures in the year 2020 lack the capacity to support national mobilization plans within the framework established during World War II.

The new economic status and positions of prestige and power for the industrial states have fostered a general rise of nationalism worldwide that has affected U.S. international political influence adversely and has resulted in the expulsion of U.S. forces from U.S. overseas bases and port facilities and in a repossession of the land, despite any previous long-term political or military agreements. This has prompted the Soviet Union to pursue economic and friendship ties with many of these nations.

By 2020, the growth of the U.S. population and its cities, especially those contiguous to and within the vicinity of military bases and installations, has confounded the withdrawal and restationing of U.S. forces within CONUS during the past decade or so. Environmental issues of pollution and waning resources, for example, along with demographic factors (e.g., an aging population, ethnic redistribution) and a general change of attitude and values of the U.S. citizens toward war and international involvement, are inhibiting military stationing and reducing investments in installations.

APPENDIX B

EXPANDED THEMES OF
BRAVO 2020: U.S. WORLD PEACEKEEPER

BRAVO 2020: U.S. WORLD PEACEKEEPER

The world economy in 2020 is brisk and highly competitive. The United States, Canada, Europe, and Japan, the leading markets of the 20th century in heavy industrial products, automobiles, and other manufactured products, are now the world leaders of high-tech products, services, information, and knowledge programs and systems. Former 20th century industrial states along with newly industrialized nations are supplying the world with heavy industrial products and most other high-demand manufactured consumer products that were formerly produced by the nations listed above. Most nations of the world, except for the very poorest, are achieving a new economic prosperity that is expanding their horizons, while altering their political and social infrastructures. Since the turn of the century, new economic and security agreements, many ad hoc, have been replacing eroding 20th century treaties and agreements.

The highly competitive world economy along with a broad transfer of technology have generated an increased frequency of trade wars and political and economic power competitions. Notwithstanding, most of the industrial states are trading off a new growth of nationalism for economic development and investment as a solution to financial and unemployment problems. This has strengthened U.S. international political and economic influence and has preserved U.S. military presence overseas. To most nations, the United States is the world's colossus.

By 2020, the achievements of science and the advances of high technology in Western postindustrial states have offset the economic loss of heavy industries and, coupled with speciality industries, their infrastructures are capable of supporting mobilization plans for contingencies within the WW II framework.

National pride within the United States is high, as is the economy, and although social investment remains the foremost national budget expenditure, it is followed by a sizeable defense budget. Both the current Congress and the Administration as well as the general populace support extensive military programs. In general, U.S. community infrastructures (economies, demographics, resources, attitudes and values, etc.) underpin military stationing requirements and investments in installations. The enactment of a universal public service program, which includes the military, not only bolsters the general economy but also answers national unemployment problems. Other areas of high national interest are education, science and technology, and space programs.

Most nations of the world, except the very poorest, have been highly armed by the new arms merchants of the industrial states and the number of states with nuclear weapons and delivery systems in their arsenals is 40 percent more than those known to have existed in 1995. Despite some strategic nuclear arms reductions by the United States and the Soviet Union early in the new century, the result of negotiations stemming from U.S.-Soviet arms control meetings in the late 1980s, U.S. and Soviet strategic nuclear capabilities remain high.

The Soviet Union, dissatisfied to remain an industrial state while the United States is an advanced postindustrial, has embarked on an ambitious plan of internal economic development encompassing its entire nation. However, it is more adventuresome militarily than in the 1990s, continues to support its client states, and has permitted economic fusion of many East European states with Western Europe. Even so, the Soviet European sector remains highly capable of waging war if provoked.

APPENDIX C

EXPANDED THEMES OF
CHARLIE 2020: NEONATIONALISM WORLD

CHARLIE 2020: NEONATIONALISM WORLD

Nations of the world by 2020 have increasingly become more nationalistic, despite an increasing number of nations adopting more representative, and mostly parliamentary, forms of government. These conditions have evolved over the past several decades from a gradual transformation of many formerly Third World countries that had been modernizing their societies with the aid of the American government and its private enterprises. Their international status has been raised from that of Third World nations to that of modern industrial nations.

Believing that the influx of technology and Western people and their ideas was changing their societies and obscuring their national identities, many of these industrial nations have sought refuge in a revival of nationalism. This has occurred despite unprecedented national economic growth and a higher standard of living for their people over the past two decades. These countries have nationalized all industries, expelled all Western foreigners, including their military, and have reclaimed the real estate of all U.S. military bases and port facilities. This rise of nationalism worldwide has suppressed U.S. opportunities for international political and economic influence.

The United States, the foremost postindustrial nation of the world, over the past several years politically has advocated maintaining a strong military defense. Its investments in technologically advanced military systems, especially those using the fourth dimension of outer space, have surpassed any previous military investments of the past several decades. Such systems have reduced the military requirement for massive land forces and placed an increasing emphasis and demand for technology- and space-oriented counterstrategies of land warfare. This is essential since U.S. heavy industries, including arms manufacturers, have relocated in foreign industrial nations and Western postindustrial infrastructures, along with specialty industries, lack the capacity to support national mobilization plans (from a WW II perspective). Moreover, since U.S. community infrastructures (economies, politics, demographics, resources, etc.) are inhibiting military stationing capabilities and reducing investments in installations, military strategists and analysts have devised force structures and end strengths compatible with security needs and societal characteristics without losing sight of military missions. The military, however, must find alternative training sites.

All except the very poorest of nations have been armed by the arms merchants during the latter years of the 20th century and the early years of the new century. The number of nations with nuclear weapons and delivery systems in their arsenals has increased two-thirds over those known to have them in the 1990s. Most nations have elected to maintain a military force since they are experiencing economic growth. Many of these nations are unable to cope with the challenges of a highly competitive world economy and are unable to devise the economic strategies needed to survive.

The Soviet Union is bent on the industrial modernization of its entire nation. Despite moderate and incremental bilateral strategic nuclear arms reductions with the United States, stemming from U.S.-Soviet arms control meetings in the late 1980s, the Soviet Union retains a formidable warfighting capability, yet poses less threat to Western Europe. Soviet investments in national economic and social development, however, have reduced its support to client states and have curtailed its adventuresome interests.

APPENDIX D

EXPANDED THEMES OF
DELTA 2020: MUTED BIPOLAR WORLD

DELTA 2020: MUTED BIPOLAR WORLD

Over the past decade or so, U.S. communities increasingly have rejected the presence of military bases contiguous to or within 50 miles of major cities. East-west and north-south patterns of urban sprawl throughout the nation form vast megalopolises that are encircling military bases and installations.

Many U.S. communities vehemently oppose any increased investments in military installations made to accommodate strange and new weapon systems that might pollute their environment and consume their resources. Some states have enacted environmental protection legislation that is so stringent that many installations within those states have been forced to close. Recently, organized groups of citizens, condoned by state governments, have blocked the addition to and creation of installations for new military systems, troops, and training programs that they believe would increase the risk to their community as a target of enemy attack in the event of war. Most U.S. communities are economically viable and have little need for the economic support provided by military bases. Politically, most communities, local, state, and federal, are represented by a population that is an older age and approaching 40 percent blacks, Hispanics, and Asians. The political, economic, and social influence of this near majority on U.S. national and international affairs is substantial. This impact, also, affects the U.S. society in general but is especially reflected in the U.S. national political leadership who advocate comprehensive national social welfare programs and investments. These Federal programs are followed by investments in education, space, science and technology, and defense programs.

The United States is the leading postindustrial nation of the world. A very large percentage of Americans are employed in the services, information, and knowledge sector of the U.S. economy. Heavy U.S. industries, such as steel and chemicals, as well as most manufacturers of automobiles, appliances, and building supplies have relocated in foreign nations from which the U.S. imports such needs. Specialty industries, such as plastics and high-technology industries, support a flourishing U.S. economy. A comparable situation exists in the other Western postindustrial nations of Canada, Europe, Australia, and Japan. Most Western strategic analysts believe that the Western postindustrial infrastructures, along with their specialty industries, lack the capacity to support national mobilization plans in the event of a major war.

Worldwide, over the past decade, many nations have traded off nationalism, that had been growing since the turn of the century, for economic security and development. This has strengthened U.S. international political, economic, and military influence and has preserved U.S. military presence, bases and installations, overseas. With this arrangement, these nations not only receive financial assistance from the United States but they also receive information, services and training, and most importantly, a security umbrella.

Most nations of the world, except the very poorest, are heavily armed with conventional weapons. Others, additionally, are armed with more modern high-tech weapons systems. The number of nations with nuclear weapons and delivery systems is about 40 percent greater since 1995. The Soviet Union, beset with constant economic setbacks, is bent on national economic catch-up throughout its vast territory to enable it to achieve postindustrial status and compete with the United States. Although the Soviet military is less adventuresome militarily and is neglecting its client states, its warfighting capabilities remain formidable and continue to be a threat to the free world.

APPENDIX E

DISTRIBUTION

Office of the Secretary of Defense

Deputy Under Secretary for Policy
Assistant Secretary (Int'l Security Affairs)
Director, Net Assessment
Assistant Secretary (Int'l Security Policy)

Office of the Joint Chiefs of Staff

Director of the Joint Staff
Director J-1 (Manpower and Personnel)
Director J-3 (Operations)
Director J-4 (Logistics)
Director J-5 (Strategic Plans and Policy)
Director J-7 (Operational Plans and Interoperability)
Director J-8 (Force Structure, Resource, and Assessment)

Department of Defense

Director, Defense Intelligence Agency
Commandant, Defense Intelligence College
Director, Defense Logistics Agency
Director, Defense Security Assistance Agency

Headquarters, Department of the Army

Office of the Secretary
Under Secretary
Asst. Secretary (Civil Works)
Asst. Secretary (Financial Management)
Asst. Secretary (Installations and Logistics)
Asst. Secretary (Manpower and Reserve Affairs)
Asst. Secretary (Research, Development, and Acquisition)

Office of the Chief of Staff

Vice Chief of Staff
Director of the Army Staff
Political Advisor
Commander, Strategic Defense Command
Director, Concepts Analysis Agency
Commander, Operational Test and Evaluation Agency
Chief, Assessment and Initiatives Group
Director, Management
Chief, Installation Management Division
Director, Program Analysis and Evaluation

ODCSOPS

Deputy Chief of Staff for Operations and Plans
ADCSOPS (Joint Affairs)
Technical Advisor to the DCSOPS
Director, Strategy, Plans, and Policy
Chief, Strategy, Plans, and Policy Div.
Chief, Long-Range Planning Group
Chief, Politico-Military Div.

Chief, War Plans Div.
 Director, Space and Special Weapons
 Director, Training
 ADCSOPS (Force Development and Integration)
 Director, Close Requirements and Integration
 Director, Deep Requirements and Integration
 Director, Program Integration
 Director, Operations Readiness and Mobilization
 Chief, Army Initiatives Group
 ODCSLOG
 Director of Plans and Operations
 Commander, Logistics Evaluation Agency
 ODCSPER
 Asst. Deputy Chief of Staff for Personnel
 ODCSINT
 Assistant Deputy Chief of Staff for Intelligence
 Director of Foreign Intelligence
 ODISC4
 Deputy Director (C4) Systems Integration
 OCOE
 Deputy Chief of Engineers
 OCAR
 Chief, Force Structure, Mobilization and Modernization Div.
 NGB
 Chief, Office of Policy and Liaison

 Headquarters, Department of the Navy
 Director, Strategy, Plans and Policy Div.

 Headquarters, U.S. Marine Corps
 Deputy Chief of Staff for Plans, Policies and Operations
 Director, Plans Div.

 Headquarters, Department of the Air Force
 Deputy Chief of Staff, Plans and Operations
 Director of Plans
 Assistant Chief of Staff, Studies and Analyses

 Service Schools
 Commandant, Air War College
 Commander, Air University
 President, National Defense University
 Director, Institute for National Strategic Studies
 Commandant, National War College
 Commandant, Armed Forces Staff College
 President, Naval War College
 Commandant, Industrial College of the Armed Forces
 Commanding General, U.S. Army Combined Arms Center
 Commanding General, U.S. Army JFK Special Warfare Center
 Director, Training and Education Center, Marine Corps Combat Development
 Center
 Superintendent, U.S. Military Academy

Central Intelligence Agency
National Intelligence Officer for General Purpose Forces
Deputy Director for Intelligence

Combined Commands

XO to SACEUR, SHAPE
Chief of Staff, Supreme Allied Command, Atlantic
CINC, U.S. Space Command
CINC, ROK/U.S. Combined Forces Command

Unified Commands

CINC, US SOUTHCOM
DCINC, US EUCOM
CINC, US PACOM
CINC, US LANTCOM
CINC, US SOCOM
Director, Plans, Policy and Doctrine, US SOCOM
CINC, US CENTCOM

Major CONUS Commands

CG, AMC
CG, FORSCOM
CG, TRADOC
CG, INSCOM

Major Overseas Commands

CINCUSAREUR/Seventh Army
CG, U.S. Army Japan
Deputy Commander, Eighth U.S. Army/US Forces Korea
CG, WESTCOM
Commander, U.S. Naval Forces Korea

Libraries

CAA
Pentagon
Defense Technical Information Center
USAWC

Other

CG, U.S. Army Logistics Center

UNCLASSIFIED

SECURITY CLASSIFICATION OF THIS PAGE (When Data Entered)

REPORT DOCUMENTATION PAGE		READ INSTRUCTIONS BEFORE COMPLETING FORM
1. REPORT NUMBER 88001	2. GOVT ACCESSION NO.	3. RECIPIENT'S CATALOG NUMBER
4. TITLE (and Subtitle) Alternative World Scenarios for Strategic Planning		5. TYPE OF REPORT & PERIOD COVERED Futures Report, The 21st Century to the year 2020
		6. PERFORMING ORG. REPORT NUMBER
7. AUTHOR(s) Charles W. Taylor		8. CONTRACT OR GRANT NUMBER(s)
9. PERFORMING ORGANIZATION NAME AND ADDRESS U.S. Army War College Strategic Studies Institute Carlisle Barracks, PA 17013-5050		10. PROGRAM ELEMENT, PROJECT, TASK AREA & WORK UNIT NUMBERS
11. CONTROLLING OFFICE NAME AND ADDRESS U.S. Army War College Strategic Studies Institute Carlisle Barracks, PA 17013-5050		12. REPORT DATE January 20, 1988
		13. NUMBER OF PAGES 91
14. MONITORING AGENCY NAME & ADDRESS (if different from Controlling Office)		15. SECURITY CLASS. (of this report) Unclassified
		15a. DECLASSIFICATION/DOWNGRADING SCHEDULE
16. DISTRIBUTION STATEMENT (of this Report) Approved for public release; distribution unlimited.		
17. DISTRIBUTION STATEMENT (of the abstract entered in Block 20, if different from Report)		
18. SUPPLEMENTARY NOTES		
19. KEY WORDS (Continue on reverse side if necessary and identify by block number) Alternative world scenarios; scenarios; forecasting; cone of plausibility; long-range planning; futures.		
20. ABSTRACT (Continue on reverse side if necessary and identify by block number) This Futures Report presents a set of four alternative world environments (scenarios) for the year 2020 that are suitable for strategic planning throughout the Department of the Army. The scenarios, projected to 2005 and 2020, present possible outcomes/end states in the world and domestic political, economic, technological, and social environments. Notions of the scenarios challenge widely-held assumptions about the future structure of the Army. The scenarios are plausible, realistic, and appropriate for national defense planning and have been recommended by a Harvard Seminar "to have even wider decision-making utility for the Army and, perhaps, for the Department of Defense as a whole."		