

AD-A201 048

LE COPY

2

SUMMARY

of

THE DEFENSE SCIENCE BOARD 1978 SUMMER STUDY

on

"ACHIEVING IMPROVED NATO EFFECTIVENESS THROUGH ARMAMENTS COLLABORATION"

31 July - 11 August 1978

Naval War College

Newport, Rhode Island

DTIC
ELECTE
NOV 28 1988
S D
cu
H

The Honorable Walter B. LaBerge, Chairman

Mr. O. C. Belleau, Vice Chairman

December 1978

INTRODUCTION STATEMENT I
Approved for public release
Distribution Unlimited

88 11 28 066

UNCLASSIFIED

SECURITY CLASSIFICATION OF THIS PAGE

REPORT DOCUMENTATION PAGE				Form Approved OMB No 0704-0188 Exp. Date Jun 30, 1986	
1a. REPORT SECURITY CLASSIFICATION UNCLASSIFIED		1b. RESTRICTIVE MARKINGS NONE			
2a. SECURITY CLASSIFICATION AUTHORITY N/A		3. DISTRIBUTION / AVAILABILITY OF REPORT Distribution Statement A. Approved for Public Release. Distribution is Unlimited.			
2b. DECLASSIFICATION / DOWNGRADING SCHEDULE N/A					
4. PERFORMING ORGANIZATION REPORT NUMBER(S) N/A		5. MONITORING ORGANIZATION REPORT NUMBER(S) N/A			
6a. NAME OF PERFORMING ORGANIZATION Defense Science Board, Ofc of the Under Secy of Def (A)		6b. OFFICE SYMBOL (if applicable) DSB/OUSD (A)	7a. NAME OF MONITORING ORGANIZATION N/A		
6c. ADDRESS (City, State, and ZIP Code) The Pentagon, Room 3D1020 Washington, D.C. 20301-3140		7b. ADDRESS (City, State, and ZIP Code) N/A			
8a. NAME OF FUNDING / SPONSORING ORGANIZATION Defense Science Board/OUSD (A)		8b. OFFICE SYMBOL (if applicable) DSB/OUSD (A)	9. PROCUREMENT INSTRUMENT IDENTIFICATION NUMBER N/A		
8c. ADDRESS (City, State, and ZIP Code) The Pentagon, Room 3D1020 Washington, D.C. 20301-3140		10. SOURCE OF FUNDING NUMBERS			
		PROGRAM ELEMENT NO. N/A	PROJECT NO. N/A	TASK NO. N/A	WORK UNIT ACCESSION NO. N/A
11. TITLE (Include Security Classification) Summary of the Defense Science Board 1978 Summer Study on "Achieving Improved NATO Effectiveness Through Armaments Collaboration", UNCLASSIFIED					
12. PERSONAL AUTHOR(S) N/A					
13a. TYPE OF REPORT Final		13b. TIME COVERED FROM N/A TO N/A	14. DATE OF REPORT (Year, Month, Day) 78/08/11		15. PAGE COUNT 33
16. SUPPLEMENTARY NOTATION N/A					
17. COSATI CODES			18. SUBJECT TERMS (Continue on reverse if necessary and identify by block number)		
FIELD	GROUP	SUB-GROUP			
19. ABSTRACT (Continue on reverse if necessary and identify by block number)					
20. DISTRIBUTION / AVAILABILITY OF ABSTRACT <input type="checkbox"/> UNCLASSIFIED/UNLIMITED <input type="checkbox"/> SAME AS RPT. <input type="checkbox"/> DTIC USERS			21. ABSTRACT SECURITY CLASSIFICATION		
22a. NAME OF RESPONSIBLE INDIVIDUAL Diane L.H. Evans			22b. TELEPHONE (Include Area Code) (202) 695-4158/6463		22c. OFFICE SYMBOL DSB/OUSD (A)

SUMMARY

of

THE DEFENSE SCIENCE BOARD 1978 SUMMER STUDY

on

"ACHIEVING IMPROVED NATO EFFECTIVENESS THROUGH ARMAMENTS COLLABORATION"

31 July – 11 August 1978

Naval War College

Newport, Rhode Island

The Honorable Walter B. LaBerge, Chairman

Mr. O. C. Boileau, Vice Chairman

December 1978



RESEARCH AND
ENGINEERING

OFFICE OF THE UNDER SECRETARY OF DEFENSE
WASHINGTON, D.C. 20301

9 January 1979

Honorable William J. Perry
Under Secretary of Defense for
Research and Engineering
Room 3E1006, The Pentagon
Washington, D. C. 20301

Dear Bill:

I am enclosing the summary of the Defense Science Board 1978 Summer Study on "Achieving Improved NATO Effectiveness Through Armaments Collaboration."

In view of the major involvement of your office and yourself, I believe that the usual procedure of sending the report to SecDef may not be applicable to this case. I will leave the choice to you.

I am also convinced that you are, as I am, very well impressed by the way Walter handled this problem and I am attaching a copy of notes to Walter and Ollie thanking them. Recommend your signing them out.

The conclusions and recommendations of the Study Group are outlined on pages 3-7 of the enclosed report. The members of the Defense Science Board Study Group believe that all of the recommendations merit careful consideration and we have structured them in such a way to permit ready implementation into specific actions. Many of the recommendations are already being acted upon within the Department of Defense.

In this regard, I am pleased to note that you have given weight to the second recommendation which would put into effect a plan for implementing the "family of weapons" concept in accordance with a program for co-development and co-production among the Four Powers. The DSB sponsored Study Group which is now completing follow-on work addressing this recommendation, under the chairmanship of Dick DeLauer, will forward their report to you in mid-January.

In particular, I would like to call your attention to the third recommendation of the attached report, which includes six proposed actions to place

increased emphasis on interoperability within the DoD and the NATO Alliance. In my judgment, shared by the Study Group, and, I believe, by most of the participants and advisors involved in our deliberations, the focus on interoperability provides the best opportunity for early achievement of the basic goal which you charged us to address last Summer. Interoperability appears to offer the highest practical immediate payoff in improved NATO effectiveness for the investment in resources the Alliance now puts into research and development.

I believe that this project has been a most useful undertaking and I am sure that all of the participants share with me our pleasure in having contributed to your significant efforts in this particular area.

I am taking the liberty of sending copies of this letter and the report to the Under Secretary of Defense for Policy and to the Chairman of the Joint Chiefs of Staff.

Sincerely,

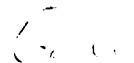

Eugene G. Fubini
Chairman
Defense Science Board

Attachments:

Letters to W. LaBerge & O. C. Boileau
Summary of DSB Summer Study on NATO

cc: USDP
Chmn, JCS

CONTENTS

	<u>PAGE</u>
INTRODUCTION	1
Study Objectives	1
Method of Approach	1
CONCLUSIONS AND RECOMMENDATIONS	3
Conclusions	3
Recommendations	4
BACKGROUND	7
Criticality of the Issue Today	7
Rate and Quality of Soviet-Warsaw Pact Conventional Buildup	8
Increased Dependence on Conventional Forces	8
Political and Economic Constraints on NATO Defense Budgets	8
The Input/Output Efficiency of Alliance Resource Use	9
Increased Desire of Members of the Alliance for Self-Sufficiency in High Technology Armaments	9
Efficiency of the Current Input/Output Process	9
US Goals Related to Armaments Collaboration	12
To Improve NATO Operational Effectiveness	12
To Increase Efficiency in the Allocation of Alliance-Wide Resources for Research, Development, and Acquisition	13
To Strengthen NATO Cohesiveness	14
To Encourage a Politically Stable and Economically Strong Western Europe and European Defense Industry	15
DSB Study Group Observation	15

or	<input checked="" type="checkbox"/>
	<input type="checkbox"/>
on	<input type="checkbox"/>
n/	

Availability Codes	
Dist	Avail and/or Special
A-1	



	<u>PAGE</u>
Current NATO/European Activities in Support of Armaments Collaboration	16
Principal NATO Agencies	16
Recent NATO Emphases	17
Extra-NATO Activities	18
DSB Study Group Observation	19
Constraints on Armaments Collaboration	19
CRITIQUE OF THE PRESENT DOD PROGRAM OF ARMAMENTS COLLABORATION	21
Main Elements of the Present DoD Program	21
Overview	21
Defense Procurement MOUs	21
Dual Production	23
Family of Weapons Concept	24
DSB Study Group Appraisal of Present DoD Program	26
Defense Procurement MOUs	26
Dual Production	28
Family of Weapons Concept	29
Emphasis on Co-Development and Co-Production	31
Reasons for Emphasizing Co-Development and Co-Production	33
A Model of Co-Development and Co-Production	33
Implementing the Model: A First Step	36
Summary of DSB Study Group Proposal for a Family of Weapons Concept	39
OTHER DSB STUDY GROUP RECOMMENDATIONS FOR IMPROVING EFFECTIVENESS	40
Common Defense Planning	41
Joint Requirements	41
Interoperability	41
Standardization Agreements (STANAGs)	41
Equipment Replacement Schedules	42

	<u>PAGE</u>
Increased US Emphasis on Interoperability	42
Policy on Established NATO and JCS Priority Areas	43
Implications for Systems Acquisition Process	43
An Interoperability Action Plan	44
Improved/Modified US Procedures and Regulations	44
Guidelines and Rules for Teaming	44
Information Release Cycle	44
Release of Performance Data	44
Release of EW Vulnerability Data	44
Contract Terms and Conditions in International Procurement	45
Focused Guidance in RFPs, Including Data Rights	45
Interpretation of Anti-Trust Laws	45
OMB Circular A-109	45
Other Ways to Provide Long Term Commitments	46
Industry Involvement in a Strategy for Co-Development and Co-Production	46
Improved Approaches to Collaboration	47
Avoid Commitment to a Single Overall Approach	47
Define Objectives of Armaments Collaboration and Concept for Achieving Them	47
Consider a Variety of Approaches	47
Start with Specific Programs	47
KEY ISSUES	48
Military	48
Differences in Systems Requirements	48
Differences in Equipment Specifications	49
Vulnerability of Production Base	49
Political	49
Forum(s) for Armaments Collaboration	49
Extra-NATO Arms Sales	49
Long Term Program Commitments	50
Economic	50

	<u>PAGE</u>
APPENDIX A - STUDY PARTICIPANTS	53
DSB Study Group	53
Management Representatives from Industry	54
Technology Representatives from Industry	55
US Government and Other Experts	56
FIGURES	
1. A Co-Development/Co-Production Model Facilitating Technology Transfer	34
2. First Step in "Family of Weapons" Concept	37
TABLES	
1. Elements of USDR&E Proposed Program for Armaments Collaboration	22
2. DSB Study Group Appraisal of OSD's Present Program	27

INTRODUCTION

Between 31 July and 11 August 1978, nine members of the Defense Science Board (DSB) met at the Naval War College in Newport, Rhode Island for a Summer Study on "Achieving Improved NATO Effectiveness Through Armaments Collaboration." The Summer Study was chaired by Dr. Walter B. LaBerge, Under Secretary of the Army, with Mr. Oliver C. Boileau, President of Boeing Aerospace Company, as Vice Chairman.

Study Objectives

The terms of reference for the Study stated two basic tasks or objectives:

- (1) To review the goals and objectives underpinning NATO interoperability and standardization policies and programs; and
- (2) To determine specific actions that the US Government and US industry could take to better achieve stated goals and objectives.

In a plenary meeting of the DSB as a whole on the opening day of the Summer Study, Dr. William Perry, Under Secretary of Defense for Research and Engineering (USDR&E), provided further guidance to the study. In brief, he stated that the problem of achieving improved NATO effectiveness through armaments collaboration is fundamentally one of getting compatible and better equipment into NATO forces more quickly for the combined resources the Alliance now spends on research and development. Dr. Perry asked the DSB specifically:

- To review and critique OSD's current three-part approach to getting more out of the \$16 billion worth of Alliance R&D - \$4 billion by the European NATO members and \$12 billion by the US; and
- To provide imaginative and realistic ideas as to how the problem could be better addressed and solved.

Method of Approach

Under the direction of the Chairman and Vice Chairman of the Study, an intensive schedule of briefings and discussions had been laid out in

advance to cover crucial aspects of the problem. In brief, the study schedule provided for:

(1) Reviewing current US and NATO procedures, policies, and perspectives on armaments collaboration and NATO rationalization, standardization, and interoperability (RSI). This was accomplished in two full days of briefings by fifteen experts and managers from the Joint Chiefs of Staff and the three Services, from the Departments of Defense and State, from NATO, and from industry and research organizations.

(2) Assessing US industry interests, perceptions, experience, and problems associated with armaments collaboration within NATO. This was accomplished in two full days of candid discussion with top management personnel of ten key companies representative of US aerospace, electronic, automotive and other defense industries. In addition to the DSB Study Group members, eight senior officials from the US Government also participated in these discussions with industry representatives.

(3) Analyzing the implications of technology sharing and technology transfer as a central aspect of armaments collaboration. Twelve experts on technology and technology transfer from US industry were invited for a special one-day session devoted entirely to discussion with the DSB Study Group of problems, policies, and procedures for technology sharing and transfer. The experts included technical directors and managers from aerospace, electronic, propulsion and automotive industries and included several with prior government experience.

(4) Researching, discussing, and developing a consensus on the critical factors and issues affecting US approaches to armaments collaboration. The two weeks of the Summer Study provided, in addition to the above, for four full days for discussion and individual research by members of the DSB Study Group.

Study Group members, industry representatives, and US Government and other experts who took part in the study are listed in Appendix A.

CONCLUSIONS AND RECOMMENDATIONS

Conclusions

- (1) US policy on armaments collaboration should give at least comparable weight and emphasis to interoperability as to standardization of complete systems.
- (2) The present DoD program of armaments collaboration - based on bilateral defense procurement MOUs, dual production, and the family of weapons concept - is a beginning that should be broadened to give emphasis to co-development and co-production.
- (3) An approach based on co-development and co-production affords the best opportunity to build strong industrial and national incentives into collaboration and to maintain healthy competition.
- (4) Both the US and European NATO states are in formative periods with respect to armaments collaboration and the US should remain open and flexible and consider a range of approaches to standardization and interoperability and learn from experience.
- (5) Certain US governmental procedures and regulations should be reviewed and revised to facilitate armaments collaboration and give focus to priority issues pertaining to standardization and interoperability. Major areas needing improvement are:
 - a. Rules and guidance to industry on acceptable trans-Atlantic teaming arrangements.
 - b. Incorporation into system acquisition documentation and contracts of requirements for and criteria of standardization and interoperability.
 - c. Information release procedures especially for performance data and EW vulnerability data.
 - d. Provisions for protecting intellectual property and enabling transfer of technology and data rights as required and for value received.
 - e. Accommodation to system acquisition procedures and regulations of other countries in international procurement contracts.

- (6) Several national policy issues, which go beyond the interests and jurisdiction of DoD, significantly affect NATO armaments collaboration and need resolution. These include:
- a. The principal political forum(s) through which the DoD should pursue armaments collaboration within NATO - e.g. bilateral, Four Power, IEPG, NATO agencies.
 - b. The relation between US arms export policy and NATO armaments collaboration policies as they affect third country sales.
 - c. The basis on which the US can make more formal or legal, multi-year commitments to NATO allies on specific armaments collaboration projects.
 - d. The impact on the US economy of military technology transfer and the relation of military technology transfer to other technology transfer policies.

Recommendations

- (1) Prepare for signature by the Secretary of Defense armaments collaboration policy statements or directives, including the following points:
- a. The strong US commitment to interoperability with the forces of the NATO Alliance, and that efforts in DoD to achieve interoperability are of equal importance to those for standardization of complete weapons systems.
 - b. Programs of international co-development and co-production should be one of the principal long-term methods of achieving Alliance equipment standardization supplementing Memorandums of Understanding which facilitate mutual trade and dual or joint production of currently available Alliance hardware.
 - c. To the degree possible, industrial competition, will be the basis for international cooperation, and that primary technology transfer will be by holder industry company rather than by governmental exchange of data packages.
 - d. The Department of Defense will consider the potential impact on the US economy (military and commercial trade) when authorizing technology transfers in the military interest of the Alliance.

Action Office: USD(P)

- (2) Initiate implementation of a plan, with SecDef and NSC approval, which puts into effect the DSB recommended program for co-development and co-production. This would include:
- a. The selection of initial pilot programs from PAPS.
 - b. The preparation of draft MOUs including the specification of
 - the conduct of source selection
 - the conduct of development
 - guidelines for initiation of production
 - guidelines for logistic support

Action Office: USDRE with
CJCS

- (3) Put into effect a specific set of actions to increase emphasis on interoperability for approval of the Secretary of Defense which will:
- a. Provide for achieving increased Alliance agreement on common military tactics and doctrine.
 - b. Provide for obtaining a military judgment of priorities for interoperability in order to emphasize programs of greater benefit.
 - c. Provide for developing within NATO, criteria for hardware interoperability and how NATO should monitor individual national programs for compliance to these criteria.
 - d. Establish procedures to ensure that appropriate NATO-wide interoperability criteria are included in US requirements documentation, mission element needs statements, RFP's and implementing contracts.
 - e. Establish procedures to ensure formal review of interoperability requirements as part of Service System Acquisition Review Councils (SSARC's) and OSD DSARC's.
 - f. Establish procedures for appropriate interoperability demonstration/certification as part of operational testing of new weapons systems.

Action Office: USDRE with
USD(P) & JCS

- (4) Implement a program to improve US industry participation in armaments collaboration including the following:
- a. Establish a mechanism for industry and labor communication with the USG on issues of armaments cooperation.
 - b. Establish incentives for US industry to seek cooperative programs which make US technology available to the Alliance, and Alliance technology available to US industry.

Action Office: USDRE

- (5) Draft and submit to the NSC a Presidential Decision Memorandum on NATO Armaments Collaboration including the following:
- a. Specify the forum or fora through which the US will deal with its NATO Allies on armaments collaboration.
 - b. Provisions for minimizing, on a case-by-case basis, restraints on our Allies, in programs of mutual cooperation, of the US policy on limitation of arms sales directed by the President and Congress.
 - c. Provisions by which the US, through the DoD and Congress, can make long-term program commitments which are credible to our Allies; and which seek improvements in Allied commitments.

Action Office: USD(P)

- (6) Prepare a plan and draft implementing directives for the approval of the Secretary of Defense to enhance armaments collaboration. These will provide:
- a. Prior to attempts at collaboration, military assessments of what aspects of a system can be designed against a US worldwide requirement, and what aspects of a system may be designed to a less encompassing NATO specification.
 - b. Explicit definition of staff authority and responsibility within OSD and DoD related to international armaments collaboration.
 - c. Improvement of the information release process to ensure:
 - The timeliness of information release authorization.
 - The appropriateness of application of existing release criteria especially in the areas of performance data and EW vulnerability data.

Action Office: USDRE

- (7) Prepare a report to the Secretary of Defense on the utility of the several hundred established NATO organizations and agencies operating in support of armaments collaboration, including recommendations for agencies to be abolished, consolidated, or reorganized, and where appropriate, revised terms of reference.

Action Office: USDRE

- (8) Establish responsibility for establishing and maintaining information and data bases in OUSDRE, but with the support of the Intelligence Community in the following areas:
 - a. Foreign Allied weapons and technology.
 - b. Foreign trade statistics and projections on military and nonmilitary high technology products and exports.

Action Office: USDRE

BACKGROUND

Criticality of the Issue Today

Achieving improved NATO effectiveness through armaments collaboration is a critical issue today for at least five reasons. These are:

- (1) The rate and quality of Soviet-Warsaw Pact conventional forces buildup.
- (2) The increased dependence of NATO on conventional forces for deterrence and defense.
- (3) Political and economic constraints on NATO defense budgets.
- (4) The "input/output" efficiency of Alliance resource use.
- (5) An increased desire of member states of the Alliance for self sufficiency in high technology armaments.

Each of these is discussed briefly below.

Rate and Quality of Soviet-Warsaw Pact Conventional Buildup. The rate and quality of Soviet-Warsaw Pact conventional forces buildup has been a subject of considerable discussion and debate during the last four or five years. There now appears to be widespread agreement among

Western officials and analysts, however, that the Soviet Union and the Warsaw Pact have been embarked on a long term force modernization and improvement program that clearly exceeds any defensive requirements.

Increased Dependence on Conventional Forces. Without diminishing NATO's reliance on US strategic nuclear forces as the ultimate deterrent or in any way reducing the US commitment to the defense of Western Europe, the Soviet-Warsaw Pact conventional forces buildup combined with rough parity in nuclear forces has resulted in an increased dependence of NATO on conventional forces for deterrence and defense. Recent emphasis on the dangers of a short war with little warning soberly signal not only an increased dependence of NATO on overall conventional capabilities but on the immediate availability and readiness of those capabilities for coordinated response.

Political and Economic Constraints on NATO Defense Budgets. While the Soviet Union has been steadily committing 11 to 14 percent of its gross national product to its defense budget, NATO states have been committing proportionately only about one-fourth to one-half that amount. Consumer demands and national priorities affecting the quality of life in the West place severe, if imprecise, limits on what levels of national resources Western governments and parliaments are willing or able to commit to defense. Such political and economic constraints on defense spending have been worsened in their impact in the West by recent inflationary pressures, energy shortages, and rising military manpower costs in most countries. Even the recent commitment of the NATO Allies to effect an annual increase of 3 percent in real terms in defense spending will not close the gap between increases in defense spending that the Soviet Union has been undertaking for years and Western decreases, nor will it increase the proportion of gross national products that NATO Allies commit to defense.

The Input/Output Efficiency of Alliance Resource Use. Former SACEUR Andrew J. Goodpaster is frequently quoted for estimating that

NATO combat effectiveness is diminished by as much as 30 to 50 percent in some cases by lack of standardization of equipment between national forces that may be expected to fight side by side. Thomas Callaghan in his now famous report on "US/European Economic Cooperation in Military and Civil Technology" has claimed that the Alliance wastes as much as \$10 billion annually by duplicative R&D and by failure to achieve economies of volume production of military equipment. Both claims are controversial and difficult to substantiate, but they indicate a fundamental problem that is addressed in more detail below.

Increased Desire of Members of the Alliance for Self Sufficiency in High Technology Armaments. A final reason the problem of armaments collaboration is critical today is that the principal industrial economies within the NATO Alliance share a set of convictions -- with important variations in degree -- that: (a) technological superiority in weapons is vital to national security and independence; (b) technology cannot be left entirely to someone else to develop; (c) military R&D underwrites a cutting edge of the evolution of high technology; and (d) high technology developed for military purposes has unpredictable but significant spinoff benefits for the civilian economy.

For such convictions (reasons), the United Kingdom, the Federal Republic of Germany, and France especially -- as well as the US -- wish to maintain, whenever feasible, self sufficiency in high technology areas of military R&D. For other, smaller or less developed states, self sufficiency across a wide spectrum is not feasible and, by national policy, may not be regarded as so desirable. Nonetheless, for states such as Italy, Canada, the Netherlands, Belgium, Norway, and Denmark self sufficiency in selected high technology areas is a vital national interest also.

Efficiency of the Current Input/Output Process

In general, the Study Group agrees that the current "input/output" process is probably not efficient. At least in comparison to the Soviet

Union and the Warsaw Pact, what NATO gets out in terms of deployed force effectiveness of the resources it puts into research, development and materiel acquisition is not without room for significant improvement. There are several classical arguments about why the current process is probably not efficient.

One argument concerns Alliance-wide allocation of military R&D funds. The roughly \$12 billion the US spends annually on military R&D contains many projects that are duplicative with or near equivalents of many projects funded by about \$4 billion in NATO European military R&D budgets. Even the \$4 billion spent annually in Europe contains some redundancies since European states also prefer to maintain self sufficiency in high technology armament areas and generally prefer to meet their military requirements from national resources when possible rather than becoming dependent on armaments imports. Additionally, the output to fielded forces from separate national selection and procurement decisions too often yields equipments that are incompatible with one another. For allied national forces mutually to support one another then requires a belated fix to make them interoperable.

A second argument concerning the efficiency of the input/output process concerns the failure to achieve economies of volume production. With a preference for procurement from national domestic sources, production runs, particularly within NATO European states, are typically small yielding higher unit costs than is believed to be the case if benefits of the "learning curve" could be achieved by larger production runs. Failure to specialize production and satisfy more NATO national requirements by trade -- so the argument runs -- contributes to inefficiency in the overall Alliance input/output process. Whereas duplicative R&D is driven principally by national desires for self sufficiency in high technology armament areas, the existence of multiple small production runs is more a function of national requirements to maintain stability of employment and a production base in many sectors.

A related argument holds that within the Alliance as a whole there is an excessive production base for armaments due to national desires

for self sufficiency and employment. Without restructuring to rationalize this overall Alliance production base -- a process that could require painful local, sectoral and national economic dislocations -- the overhead cost for individual weapon systems will be inordinately high. One way to bring overhead costs into more reasonable proportion and to reduce unit costs has been to seek or respond to export markets in extra-NATO or Third World areas.

This economic problem, which when dealt with by extra-NATO exports, complicates both the politics and the Alliance-wide economics of armaments collaboration.

Desires for high technology self-sufficiency, preferences for domestic procurement over trade within NATO, some competition for extra-NATO sales, and concerns for protection of non-military, commercial interests all contribute to restraints on technology sharing among Allies. That advanced, military technology is shared among NATO states on only a limited basis -- so a fourth argument goes -- means that Alliance-wide NATO national forces do not receive uniformly the highest quality of equipment that the combined Alliance resources could develop.

Finally, for the evidence that is adduced to indicate that the current input/output process is not efficient for the Alliance, it is argued that the many voices and negotiating forums by which NATO states try to coordinate armaments programs and policies lead to confusion, especially for industry, and inefficiency in the way that armaments are developed and produced. There is a profusion of voices and forums, both inside of and outside of the formal NATO structure, which makes it difficult, especially for competitive US companies, to know which voices and forums to heed.

However inefficient the current input/output process appears to be, the DSB Study Group cautions that this is a process that has evolved naturally to satisfy or adjudicate a wide variety of industrial and economic as well as military interests of the free nations of NATO. In particular, the DSB Study Group cautions that immediate inefficiencies

of a competitive process should not be replaced by longer term inefficiencies of an apparently more rational and efficient process that undercuts competitive incentives.

US Goals Related to Armaments Collaboration

Four key goals of armaments collaboration for the US can be distinguished. These are:

- (1) To improve NATO operational effectiveness
- (2) To increase efficiency in the allocation of Alliance-wide resources for research, development, and acquisition
- (3) To strengthen NATO cohesiveness
- (4) To encourage a politically stable and economically strong Western Europe and European defense industry.

These goals are closely interrelated and tend to be mutually reinforcing in the long run. The DSB Study Group accepts and endorses these goals, each of which is discussed briefly in the following paragraphs.

To Improve NATO Operational Effectiveness. This is and should be the overriding and immediate goal of armaments collaboration. The Study terms of reference and title indicate the predominance of this goal. Dr. Perry and Dr. Eugene Fubini, Chairman of the DSB, stressed this as the primary goal in their meetings with the DSB Study Group. The rate and growth of the Soviet-Warsaw Pact conventional forces buildup establishes the importance of this goal.

The whole NATO RSI program is aimed at achieving improved NATO operational effectiveness. Armaments collaboration is a crucial part of the omnibus term, "rationalization," -- that is, "any action that increases the effectiveness of Alliance forces through more efficient or effective use of defense resources committed to the alliance." "Standardization," defined by NATO and the US as "the process by which nations achieve the closest practicable cooperation among forces, the most efficient use of research, development, and production resources,

and agree to adopt on the broadest possible basis the use of common or compatible" procedures, equipment and tactical doctrine, depends directly on armaments collaboration. "Interoperability," or "the ability of systems, units, or forces to provide services to and accept services from other systems, units, or forces and to use the services so exchanged to enable them to operate effectively together" is the military end-in-itself and also clearly depends on forms of armaments collaboration to ensure interoperability.

To Increase Efficiency in the Allocation of Alliance-Wide Resources for Research, Development, and Acquisition. In one sense this goal is the obverse of the first. As the previous comments on the efficiency of the current input/output process of the Alliance indicated, the primary problem is to get more output in NATO operational effectiveness from the defense resources committed on an Alliance-wide basis.

The evidence that was presented to the DSB Study Group concerning potential "cost savings" or benefits of NATO standardization and interoperability with respect to reductions in duplicative R&D expenditures and unit acquisition costs is ambiguous at best, especially concerning the latter. In some cases, states may in fact end up paying slightly higher unit acquisition costs for particular systems in order to ensure that they are standardized or fully interoperable with those of another state so that their forces can fight effectively together. With respect to Alliance-wide R&D expenditures, there is more hope that cooperative reallocations could be effected that could reduce costly duplications of effort. Even here, however, this can be difficult to achieve since sovereign states only very reluctantly forego particular areas of military R&D in which they have either a national security stake or a spinoff stake for their civilian economies.

In either case, the goal of armaments collaboration as the Study terms of reference and Dr. Perry's and Dr. Fubini's discussion make clear is to produce more effectiveness for the Alliance resources committed and not to spend less. The two NATO Summit Meetings, with

President Carter in a leadership role, committed the member states to twin goals of committing more resources to NATO's defense needs and of getting more out of the resources committed. It is particularly the latter of these that armaments collaboration can help achieve.

To Strengthen NATO Cohesiveness. At the London Summit Meeting in May 1977, President Carter, stressing the need for a new major effort "to meet the military and political challenges of the 1980s," declared:

At the center of this effort must be strong ties between Europe and North America. In maintaining and strengthening these ties my Administration will be guided by certain principles. Simply stated:

- We will continue to make the Alliance the heart of our foreign policy.
- We will remain a reliable and faithful ally.
- We will join with you to strengthen the Alliance -- politically, economically and militarily.
- We will ask for and listen to the advice of our Allies. And we will give our views in return, candidly and as friends.

After proposing that the defense ministers "begin developing a long term defense program to strengthen the Alliance's deterrence and defense in the 1980s," President Carter stressed that:

As we strengthen our forces, we should also improve cooperation in development, production and procurement of Alliance defense equipment. The Alliance should not be weakened militarily by waste and overlapping. Nor should it be weakened politically by disputes over where to buy defense equipment. (underlining in original)

Specifically, the President promised efforts "to seek increased opportunities to buy European defense equipment," endorsed European efforts to cooperate more fully among themselves in defense production including creation of the Independent European Program Group (IEPG), and invited a trans-Atlantic dialogue "to explore ways to improve cooperation in the development, production and procurement of defense equipments."

To Encourage a Politically Stable and Economically Strong Western Europe and European Defense Industry. In a sense, this goal -- like the goal of strengthening NATO cohesiveness -- could be regarded as instrumental to the first two goals of improving operational effectiveness and of increasing efficiency in the allocation of resources. But because there exists some apprehension in Europe that the US might intend a domination of European defense industry by "armaments collaboration," it has appeared important to state explicitly that the US intends a genuine partnership in which political cohesiveness rests on the basis of and is coexistent with a stable and economically strong Western Europe.

In the Culver-Nunn Amendments to the Defense Appropriation Authorization Act (1977), the Congress stated this goal by writing, inter alia:

It is the sense of the Congress that standardization of weapons and equipment within the North Atlantic Alliance on the basis of a 'two-way street' concept of cooperation in defense procurement between Europe and North America could only work in a realistic sense if the European nations operated on a united and collective basis. Accordingly, the Congress encourages the governments of Europe to accelerate their present efforts to achieve European armaments collaboration among all European members of the Alliance.

DSB Study Group Observations. The DSB Study Group notes that there are no stated US goals to strengthen the US economy, to provide jobs for US industry, or to consider commercial trade. Insofar as such goals are explicit or implicit goals of NATO Allies, potential conflicts of goals are likely to exist within the Alliance.

The DSB Study Group has no general recommendation to resolve or reduce the areas of potential conflict in stated or implied goals of armaments collaboration. It merely calls attention to the possibility of potential conflict and urges caution and clarity in recognizing and dealing with this possibility.

Current NATO/European Activities in Support of Armaments Collaboration

In its briefings and deliberations, the DSB Study Group conducted a broad review of some of the principal activities now underway in NATO and in Europe to support armaments collaboration and its goals. This review covered:

- (1) The principal NATO agencies concerned with armaments collaboration,
- (2) Recent NATO emphases affecting armaments collaboration, and
- (3) Some key extra-NATO activities in the area of armaments collaboration.

Principal NATO Agencies. Since the mid 1960s the principal NATO agency dealing directly with armaments collaboration is the Conference of National Armaments Directors (CNAD) and its many sub-groups and working committees and panels. It is chaired by the Assistant Secretary General of NATO for Defense Support and supported in its committee work by members of his Division of Defense Support on the NATO International Staff. The primary groups reporting directly to the CNAD are:

- The NATO Army Armament Group (NAAG)
- The NATO Air Force Armament Group (NAFAG)
- The NATO Navy Armament Group (NNAG)
- The Defense Research Group
- The Tri-Service Group on Air Defense
- The Tri-Service Group on Communications and Electronic Equipment
- The NATO Industrial Advisory Group (NIAG) consisting of industrial representatives appointed by their governments
- The Cadre Groups on specialized aspects of standardization of equipment.

On the military side of the Alliance, the Military Agency for Standardization, reporting to the Military Committee, has played a

primary role in focusing discussions and negotiations within NATO aiming at standardization and interoperability of equipment as well as standardization of doctrine and training for national forces committed to NATO. In existence since 1951, one of the principal activities of the MAS is to coordinate many and publish all of the agreed NATO standardization agreements (STANAGs).

Recent NATO Emphases. Note has already been taken of NATO's Long Term Defense Program (LTDP) that was initiated at the London NATO Summit Meeting of May 1977 and reported on and endorsed at the Washington NATO Summit Meeting of May 1978.

The LTDP is especially significant in several respects. First, it represents, essentially for the first time in NATO's history, a strong public and mutual commitment at the highest political and military levels of the Alliance to plan realistically against a set of defined priorities over about a ten-year period. Second, it resulted from clear initiatives of the Carter Administration to reaffirm the US commitment to NATO on the basis of planning and identification of priority requirements that had already been underway on the military side of the Alliance. Third, the LTDP implies a stronger commitment to armaments collaboration by all members of the Alliance than any previous undertaking to establish and achieve NATO force effectiveness goals.

Besides the LTDP, two other recent NATO emphases are important to armaments collaboration. These are the existing NATO Armaments Planning Review (NAPR) and the proposed Periodic Armaments Planning System (PAPS). It has long been recognized that in order to enhance the possibilities for agreements to collaborate, information exchanges about requirements, replacement schedules, and R&D plans are desirable. Information exchanges do take place on an ad hoc basis in the CNAD's armament groups and subgroups. The existing NAPR, also under the CNAD, attempts to put such information exchanges on a broader and more systematic basis to facilitate armaments collaboration. The NAPR, however, in its present form is only an information system and not a planning system. A planning

system, namely PAPS, has been under consideration and study under the CNAD for about two years now. The PAPS study group is under US chairmanship. PAPS presumably would tie in very closely with the LTDP, and the acceptance of the LTDP by NATO Heads of State and Governments has given new impetus to achieving progress in developing PAPS.

Extra-NATO Activities. NATO has generally accepted the collaboration between two or three NATO states which have not emerged from formal NATO decisions, but which have been formed on an ad hoc, individual project basis. NATO steering groups have frequently been established for assisting and guiding these collaborative ventures between states which have similar requirements occurring in the same time and mutually supporting technological and industrial capabilities to meet these requirements.

To give more structure to opportunities for ad hoc or more systematic armaments collaborations, two locuses of relations within the Alliance yet outside its formal structures have emerged. These are: (a) the so-called Four Power CNAD, consisting of the National Armaments Directors of the UK, France, the FRG, and the US; and (b) the Independent European Program Group (IEPG).

The Four Power CNAD is a natural grouping, reflecting the overwhelming majority of the resources committed to Alliance deterrence and defense capabilities. Close collaboration in this forum, however, creates some resentment among the more industrialized of the smaller states who feel their relative stake in armaments collaboration is as large while their power to influence collaborations is diminished.

The more natural forum for the smaller industrial states of Europe would be an intra-European one. With strong encouragement from the US, the Eurogroup was formed in 1968 within NATO as an instrument for coordinating the European portion of NATO's defense effort. Eurogroup, in effect, constitutes a subgroup within NATO representing all European members of NATO except France, Portugal and Iceland. By 1975 Eurogroup had become the principal forum for reconciling intra-European interests

with trans-Atlantic interests in armaments collaboration. By the end of 1975, however, when the absence of France in Eurogroup was felt and France indicated greater willingness to participate actively in some intra-European forum outside the formal structure of NATO, the Eurogroup Ministers called for the creation of such a forum that could include France. The IEPG was thus created in February 1976, with the blessing of Eurogroup. As the now dominant intra-European forum for armaments collaboration, the IEPG appears to be committed to a flexible and evolutionary, pragmatic and inclusive approach to armaments collaboration within Europe. Principal activities are carried out under three panels: an Equipment Planning Panel, chaired by the UK; a Specific Projects Coordinating Panel with eleven equipment study groups, chaired by Belgium; and a Defense Economics and Procedures Panel with five sub-groups, chaired by the FRG. The IEPG itself is chaired by Italy. The IEPG is now engaged in a trans-Atlantic dialogue on armaments collaboration with the US and Canada.

DSB Study Group Observation. It is not for lack of organization that cooperation fails. The problem of finding the basis for collaboration lies deeper than finding the right form of organization, however important the organization of armaments collaboration efforts is.

Constraints on Armaments Collaboration

In view of the background of armaments collaboration within NATO, the DSB Study Group cautions that US programs of armaments collaboration:

(1) Should provide for US self interests as well as Alliance-wide interests, and

(2) Must provide for a realistic and equitable distribution of burdens and benefits of defense spending among all the Allies.

With respect to the first point, the DSB Study Group acknowledges that some US policies and programs in the past have amounted more to obstacles to armaments collaboration than to solutions and that Europeans

have many sensitivities, suspicions, and complaints about US technological and industrial assertiveness or domination with respect to Alliance-wide defense markets and requirements.

However, just as Europeans are more strongly asserting and the US is acknowledging that armaments collaboration must rest on a firm foundation of maintaining the economic and industrial health of their states, so too must the US - the largest and the strongest of the Allies - maintain its economic and industrial health not only for its own sake, but for the sake of the overall strength of the Alliance.

Secondly, armaments collaboration will be successful in achieving its goals only to the extent that collaborating allies are assured that both the burdens and the benefits of defense spending are realistically and equitably distributed among them. This is, of course, more easily stated in theory than applied in practice among allies who have:

(1) Conflicting national interests and priorities, ranging from a desire for technological and arms independence on one end of the spectrum to desires to acquire technology for development and to willingness to accept or embrace arms dependence or interdependence on the other end of the spectrum.

(2) A variety of national and functional motivations to collaborate. These vary widely in the degree and priority of importance that attach to economic, industrial, political, and military motivations.

(3) Wide disparity in technological and manufacturing capabilities and aspirations. Within Europe, at least three distinct tiers or levels are distinguishable among (a) the UK, France, and Germany with a full range of capabilities; (b) Italy, the Netherlands, Belgium, Norway and Denmark, with clear capabilities in limited areas; and (c) other European NATO states with very limited technological and manufacturing capabilities to develop and produce armaments.

(4) A ten-year history of collaboration within Europe and an imbalance of military trade with the US.

CRITIQUE OF THE PRESENT DOD PROGRAM OF ARMAMENTS COLLABORATION

In its review and analysis of the present and proposed DoD program for armaments collaboration, the DSB Study Group took special note of the evolution of the main elements of that program, and further noted the principal arguments in favor of and against each element in the present program. Against this background, the DSB Study Group then examined concrete ways to improve the present program, taking into account suggestions made by management and technology representatives of US industry particularly with respect to the newest and leading edge of the present DoD program -- the "family of weapons" concept. Finally, the DSB Study Group examined the principal advantages of a revised approach to the family of weapons and some of its remaining difficulties.

Main Elements of Present DoD Program

Overview. As outlined by Dr. Perry, the main elements of the present program of armaments collaboration being followed by OUSDR&E are:

- (1) A series of bilateral defense procurement Memorandums of Understanding (MOUs).
- (2) A series of dual production agreements for systems in the US and in Europe.
- (3) A proposed "family of weapons" concept for allocating and specializing development of new requirements on an Alliance-wide basis.

Table 1 depicts the principal objectives, approach to implementation, and status and characteristics of each of these elements.

Defense Procurement MOUs. Since US defense industries have more experience in selling in Europe than do European defense industries in selling in the US, the principal expectation of bilateral defense procurement MOUs, such as the one which was signed between the UK and the US in September 1975, is to give European industries a better chance to bid and succeed in selling in the US defense market. Under the UK-US MOU, one British firm, Marconi Communications Systems, Ltd., has recently

TABLE 1
ELEMENTS OF USDR&E PROPOSED PROGRAM
FOR ARMAMENTS COLLABORATION

Objective	Approach	Status Characteristics
Facilitate military trade and industrial involvement	Opens defense markets on a bilateral basis	Underway
Standardize, protect national economies, and promote industrial involvement through licenses	License and share total market	Examples exist Needs for equipment determined nationally
Distribute responsibility for development and possible production and get better/more weapons	Specialize development	Longer term Starts with agreed upon doctrine/requirements Assigns functional segments of market

**Defense
Procurement
MOUs**

**Dual
Production**

**Family
of
Weapons**

been awarded a major subcontract on a US Army development -- namely, the Single Channel Ground Air Radio System (SINGGARS). It is not likely that such defense procurement MOUs will significantly, in and of themselves, alter the balance of military trade between North America and Europe, but they could stimulate more trade and better reciprocal opportunities to select the best systems or subsystems development and production capabilities. While there was some initial criticism of the UK-US MOU as establishing a special relationship, the US has offered to negotiate similar MOUs with all NATO partners and has signed one with Norway. Criticism still remains, however, that this approach perpetuates a pattern of many unbalanced streets of trade between the US and European NATO states and hampers intra-European rationalization of armaments policies and defense industries.

Dual Production

Almost since the beginning of the Alliance, individual states have satisfied immediate requirements, averted development costs, or acquired particular technologies by arranging the negotiation of rights to produce an ally's proven system under license to their domestic industries. During the early years of the Alliance many licenses flowed from the US to Europe to provide for European (or dual with American) production of thousands of such systems as Hawk air defense missiles, Sidewinder air-to-air missiles, and Bullpup air-to-surface missiles. Licenses have also flowed for a long time in the other direction -- perhaps, most successfully for the British 105mm tank gun, but also less successfully for higher technology systems such as the British B-57 Canberra aircraft, the French AN/TPS-58 radar, the Dutch MK-87 fire control system, and most recently the French-German Roland air defense missile system.

As a specific element of armaments collaboration to achieve standardization or interoperability, dual production -- or licensed production -- was proposed as a principal approach in the second annual report of the Secretary of Defense to the Congress on NATO rationalization/standardization in January 1976 and endorsed by the Congress in the

Culver-Nunn Amendments to the Defense Appropriation Authorization Act, 1977 passed later that year.

Dual or licensed production maintains some clear-cut advantages over direct military purchase from the industry of the developing state:

(1) It does achieve a degree of standardization among participating states so long as reasonable configuration control is maintained.

(2) Licensee states do not have to fund separate development and economies are effected.

(3) The approach minimizes potential hardship to the economy of the non-developing state by

a. Minimizing outflow of funds for direct purchase.

b. Providing employment in domestic industries licensed to produce.

(4) It increases the survivability of the Alliance production base with lines on both sides of the Atlantic.

(5) It does not depend on mutual agreement on and coordination of the timing of requirements, and the need for a particular system is determined nationally, thus minimizing complicated negotiations.

Family of Weapons Concept. The family of weapons concept is new and represents the leading edge of the present DoD program of armaments collaboration. As described by Dr. Perry to the DSB Study Group, the concept has three distinctive features:

(1) It specifically aims at rationalizing the use of collective Alliance R&D resources by proposing and agreeing on a distribution of responsibility for development (and possibly for production) for a set of common weapon system requirements.

(2) By thus specializing development - and later sharing technology - it should enable the Alliance to develop and produce better and more, as well as standardized, weapons for Alliance forces at a given level of resources expended without serious penalty to individual national interests.

(3) It represents a longer term solution than the two previous elements of the present DoD program and depends critically on early agreement among collaborating allies on doctrine and common requirements and, implicitly, on assigning functional segments of a market.

Central to the family of weapons concept is that some of the shortcomings of individual weapon system collaborations can be eased or overcome by a collaboration that encompasses several systems in a specified functional or technological "family." The concept attempts to optimize the advantages of single source developments and of individual collaborations. It requires collaborating allies to agree that one will assume responsibility for developing one weapon in a family while the others assume responsibility for other weapons in the same family and that they also agree in advance to share the results of their separate developments. They must also mutually agree not to conduct competing developments for the systems assigned to the others. Depending on the circumstances, production could be single source, dual production, or joint production for each developed system.

Possible examples of application of the family of weapons concept have been suggested for the next generation of antitank weapons or of air-to-air missiles.

There are acknowledged difficulties with the concept which is still in embryonic stages:

(1) Should a "family" be defined primarily by function (e.g., antitank vs air-to-air) or by its technology (e.g., type of guidance or propulsion)?

(2) Is it possible to coordinate replacement schedules sufficiently for a family of weapons when this is difficult already on an individual weapon system basis?

(3) While in some ways the specialized single-source development seems to imply a corresponding division of an extra-NATO market and thereby ease or finesse difficult negotiations on this issue, are functional segments of that market similar enough or predictable enough

to the corresponding segments of the NATO market to facilitate acceptance of specialization?

(4) Can different political interests in possible Third World markets be accommodated under this concept?

DSB Study Group Appraisal of Present DoD Program

Table 2 presents a summary of the DSB Study Group's appraisal of the present DoD program of armaments collaboration. The following paragraphs briefly elaborate the comments contained therein.

Defense Procurement MOUs. One of the principal arguments in favor of continuing this element of the present program is that it is already underway and represents a beginning for armaments collaboration. It is an approach that aims directly at minimizing or removing barriers to military trade. The UK-US MOU was strongly desired by the British for this reason. Being bilateral, MOUs are relatively easy to negotiate and can be developed without engaging the complex international machinery of NATO or the IEPG. Besides offering equal and reciprocal opportunities for participation in each other's defense markets, defense procurement MOUs facilitate opportunities for industrial cooperation among the defense industries of participating states.

On the other hand, bilateral defense procurement MOUs are potentially divisive from the point of view of the Alliance as a whole. There was some feeling in Europe that the UK-US MOU was establishing or confirming a special relationship to the relative disadvantage of other Europeans. Also, on the negative side, bilateral defense procurement MOUs aimed principally at removing formal legal and regulatory barriers and allowing allied industries to compete in the US market may not really change very much except expectations.

In sum, the DSB Study Group concludes that defense procurement MOUs can be a helpful tool in a much broader approach to armaments collaboration if they are carefully used. Using them carefully includes, at least, ensuring that other NATO allies to whom they would be attractive

TABLE 2
DSB STUDY GROUP APPRAISAL
OF OSD'S PRESENT PROGRAM

Pros	Cons	DSB Conclusion
<p>Underway — a beginning Bilateral — therefore easier Equal participation opportunities Facilitates cooperation</p>	<p>Potentially alliance divisive Won't change much—creates unachievable expectations</p>	<p>Helpful tool if carefully used</p>
<p>Security enhancement Economic incentives Standardizes Saves on development funds</p>	<p>Does not satisfy long term European needs Split markets and dual production investment Raises Third Country issues Increases costs over one source Transfers production technology</p>	<p>Good approach for near term— little chance for long term solution</p>
<p>Longer production runs feasible on each project Could satisfy two-way street Insures part of US market to Europeans and vice-versa Standardizes Saves on development funds Minimizes, but doesn't eliminate Third Country issue</p>	<p>Could end up with second best system/subsystem Limits competition—could raise costs Single design could result in no acceptable system No US participation/reduced commitment No US participation/less likely to meet US requirements Endangers each national tech base as R&D funds dry up and can endanger commercial markets Difficult to ever reenter field</p>	<p>Co-development and co-production only</p>

Defense Procurement MOUs

Dual Production

Family of Weapons

have the chance to negotiate MOUs with the US comparable to those for the UK and Norway and not allowing them to impede the emergence of other forms of armaments collaboration congenial to industry and to European integration as well as to the strength of the Alliance as a whole.

Dual Production. As noted previously, one of the principal arguments for dual production is that it enhances the security of the production base. Furthermore, a nation that acquires a weapon developed within another nation by licensed production rather than by direct purchase also decreases its cash outflow and protects domestic employment. At the level of achieving improved NATO force effectiveness, dual production of proven systems has the distinct advantage of standardizing important elements of the operational capabilities of participating nations. They may require strong international project management or firm national commitments to maintain configuration control, but when successful it is clearly one of the most attractive features of dual production.

Despite such benefits, there are, however, some significant drawbacks to dual production. As their own military technological capabilities have progressed, European industries do not wish to be merely licensees for US developed weapon systems. The principal industrial partners on both sides of the Atlantic do prefer to maintain strong development capabilities, especially in the advanced or high technology areas where spinoff benefits to civilian economies are believed to be greatest.

Again, principally from a European point of view, a major economic argument for standardization is that it should enlarge the market for any given system thereby affording economies of volume production. Dual production splits this larger market, thereby perpetuating redundant investment in production capabilities and failing to achieve the hoped-for acquisition costs savings that should be realized from a single source production. Living with a present fragmented NATO market, major weapons producers (especially in Europe, but to some extent also in the

US) have sought the unit cost relief of extra-NATO sales markets. Dual production -- while continuing the multiplicity of production sources within NATO -- severely complicates the extra-NATO or "third country" sales issues.

A final objection to dual production -- one more often voiced by US industry -- is that it involves not only the transfer of specific system technology of how the weapon works, but, more importantly from industry's point of view, vital production and manufacturing technology, which is the lifeblood of a firm's competitive capability.

The DSB Study Group sees little chance that dual production will provide much of a long term solution. Objections such as those noted based on long term technological, commercial and other national interests will make it an increasingly difficult approach to apply successfully.

Family of Weapons Concept. In its simplest form the family of weapons concept, by dividing responsibility for each weapon in a family among participating states and their industries, would make it feasible to achieve some of the economies of longer production runs for each project. This would be a clear advantage of the concept in comparison to dual production. Of course, this would be at the expense of foregoing one of the main advantages of the dual production approach, namely enhancing security of supply by providing at least two separate sources of production.

One of the strongest arguments in favor of the family of weapons concept is that it appears to satisfy European demands for a better balance on the two-way street. The US, under this concept, would agree in advance not to try to meet each requirement for the family of weapons concerned from US national industrial resources alone, but to accept European solutions for some. Within this concept, part of the US market would also be ensured to the European industries that developed and produced a member of the family, as part of the European market would be ensured to US developers and producers for their member(s) of the family.

The major operational effectiveness argument for the concept is that it would provide standardization of the weapons developed and produced to meet agreed on requirements. Both defense procurement MOUs and dual production achieve degrees of standardization also, but the standardization achieved by those approaches is on an ad hoc basis and almost incidental to achieving other objectives of the concepts, particularly in the case of the defense procurement MOUs. The principal resource-allocation argument for the concept and its essential aim is to provide a rational means of saving on the Alliance-wide expenditure of development funds. Application of the family of weapons concept with single-source producers as well as developers would also appear to minimize or at least finesse the issue of third country sales. The issue would by no means be eliminated, but agreement on a division of responsibility for developing and producing systems for NATO would tacitly or explicitly also involve early agreement in handling competition in this area.

The DSB Study Group finds that one obvious argument against the concept is that it could, by making assignments on a division of responsibility for weapons in a family, lead to the development of second best systems or subsystems. The limitation on competition could also lead to higher costs for individual systems. And finally, the lack of competition implied by the concept could lead not only to second best systems at higher costs but even to no acceptable system in some cases.

The lack of US participation in the development and production of a system may either imply or tend to cause a reduced US commitment to the program. Especially for systems, the development of which may take several years stretching across the tenure of two or more Congresses and even two Administrations, this is likely to be a problem.

Finally, there is the problem of the national technology base. If R&D funds are not committed to a specific development area, the technology base may well dry up. It is generally not adequate simply to commit research funds for the technology base since the real driving function even here is the prospect and the necessity eventually to

to produce an operational system at affordable cost that will meet specific requirements. There is a synergism between pure research and development that makes each essential to the other. If the technology base in a given technological area does dry up due to lack of development incentive and funding, it is extremely difficult to reenter the field.

All things considered, the DSB does not believe the family of weapons concept in its present form to be particularly feasible or desirable. The DSB Study Group does, however, believe that there is merit in trying to work out an arrangement across a family of weapons (as compared to on an individual weapon system basis) for a type of collaboration that will share rather than divide responsibilities on a more nearly optimum basis than at present within the Alliance. The essence of such an approach, the DSB Study Group concludes, must be an arrangement for co-development and co-production.

Emphasis on Co-Development and Co-Production

Reasons for Emphasizing Co-Development and Co-Production. Notwithstanding the difficulties in any armaments collaboration, the DSB Study Group affirms that standardization can be militarily very important. Standardization among a family of weapons should be relatively easier to achieve than on an individual weapon system basis. The various national, economic, technological and commercial interests involved can be accommodated in a larger framework than when these are handled only in a case-by-case approach. On the other hand, no grand solution to weapons standardization can be provided or imposed on the sovereign states of NATO. Between the scylla of negotiating everything case-by-case and the charybdis of seeking a grand solution, a family of weapons concept that stresses co-development and co-production is worth a good hard try.

By stressing co-development and co-production, the DSB Study Group intends that any approach using a family of weapons concept should give each participating state and its industries with the technological

capabilities a chance to participate in aspects of system or subsystem development and production. Any new weapon development requires a certain amount of "advocacy" in the competition for national resource allocations. Industrial participation in co-development and co-production helps establish the necessary in-country advocacy that can open domestic markets - US as well as European - to the longer production runs that can make the approach more economically acceptable.

Division of responsibility for development along national or even continental lines may foreclose opportunities for using the best technological capabilities available to the Alliance as a whole. An approach that provides for co-development of any system provides the greatest opportunity and assurance that the best Alliance technology will be employed at both systems integration and subsystems and component levels. Co-development and co-production with trans-Atlantic teaming and subcontracting would also permit some control of country by country trade balances. Traffic on the two-way street would be adjusted by subsystems and components more than by total systems or military end items.

With respect to one always troublesome aspect of armaments collaboration -- namely technology sharing, prime contractors and international subcontractors in a co-development and co-production program are likely to be in a better position than their governments to assess the value and fair price for the complementary technologies that must be used, shared, or licensed. Where technology needs to be transferred or would appear to be desirable to transfer could be more equitably determined under a co-development and co-production arrangement than under a single development and dual production arrangement. With co-development and co-production it is less necessary to transfer either highly sensitive system technology or critical production technology.

The other major troublesome issue of all armaments collaboration -- that is, third country sales -- would not be uniquely solved by co-development and co-production. However, co-development would allow, or even require, that this issue be confronted very early in a collaboration and a solution worked out before too many commitments and expectations are established.

A Model of Co-Development and Co-Production. The DSB Study Group queried US industry representatives for ideas or models as to how a co-development and co-production approach to the family of weapons concept could be implemented. Figure 1 presents such a model, which is commended to OUSDR&E for further critical attention and possible early application.

The model shown in Figure 1 shows only the case in which the development of a particular weapon in a family is funded by the US. A mirror-image picture would be drawn for each weapon whose development is funded by a NATO European state or group of states.

Listed in the lower half of the figure are some of the essential features of this model. First of all, the model requires that there be clear and firm trans-Atlantic agreement on (a) the requirements for and the interoperability criteria for the weapons in the family; (b) the expected sizes of the US and European national buys of each weapon so that planning can be reasonably and fairly accomplished; and (c) which government will be the sponsoring government for each development and which shares or types of shares of the co-development may be expected to be assigned to industries within other participating states. Agreement on each of these points is regarded by the DSB Study Group as essential. The last of these three points requires further elaboration by reference to the block diagram shown.

A second feature of the proposed approach is that the sponsoring government will provide 100 percent of the funding of the development. The DSB Study Group believes that even though co-development is proposed rather than a development carried out within one country alone, the principle should be maintained that the sponsoring government provides all of the development funds. Besides reducing redundancies in development, this would provide for firmer and simpler project control.

The prime industrial contractor would be an industrial company in the sponsoring country. The prime contractor would be fully responsible for the development to the sponsoring government, but would be required to select principal subcontractors from within the other participating

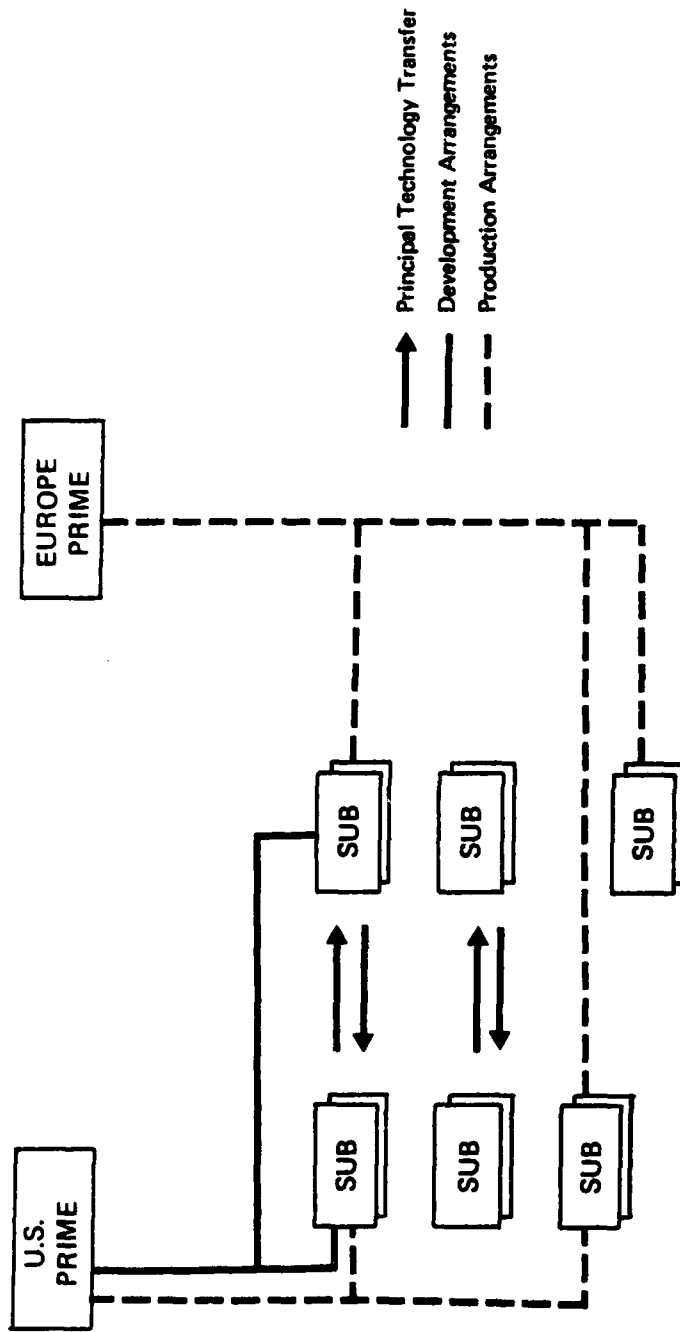

Essential Characteristics

1. Trans-Atlantic agreement on
 - Requirement/Interoperability criteria
 - Size of U.S. and European buys - (for planning only)
 - Sponsoring government - shares to others
2. Sponsor funds R&D 100%
3. Prime selects subcontractors through competition
4. Others agree not to do different designs

Figure 1 - A Co-Development/Co-Production Model Facilitating Technology Transfer

states in accordance with agreed on shares of co-development that are to go to those states. As much as possible, selection of subcontractors should be through competition to ensure use of the best available technological capability.

Finally, each of the states participating in the funding of individual weapons in the family would agree not to fund parallel or competing developments of systems or designs being sponsored by other participants.

For the case of a US sponsored development, the block diagram is intended to display some of these features and to indicate others. Since an assembly line on both sides of the Atlantic is likely to be desirable even if individual subsystems or components are not manufactured on both sides (as they would be in complete dual production), a European prime for the European production and assembly should be selected early in the process to assist and coordinate with the US prime developer/producer. The US prime developer, however, would have final responsibility for selecting the European subsystem and component developers who would later participate in the European production. Both US and European development subcontractors would assist the US prime developer in selecting counterparts on the other side of the Atlantic who could be the principal subcontractors for production and perhaps assist in development, if the subcontractors so chosen needed to acquire some technology abroad. These linkages should help to make the best technologies available for the given system since the contracting industries would both be assured a share in production. Subcontractors on both sides of the Atlantic would thus have high incentives to make the development a success by collaborative involvement of companies on the other side of the Atlantic that might otherwise seem principally to be competitors.

Since, in some cases, highly specialized or unique capabilities exist on either side of the Atlantic, the block diagram shows some subcontractors that would be subcontractors to either the US prime contractor for production or the European prime contractor for production.

The DSB Study Group believes that, however complex this model may at first appear, it has certain attractive aspects. In particular, it attempts to offer the most realistic incentives to industries to cooperate across the Atlantic and to leave to cooperating industries the principal roles in negotiating the terms of the technology transfers that must take place.

Implementing the Model: A First Step. Figure 2 presents a flow diagram for implementing the modified approach to the family of weapons concept as proposed by the DSB Study Group. This is labeled a "first step" to emphasize that the DSB Study Group believes that DoD should go slowly and learn while doing in implementing this modified approach.

The diagram is intended to be self-explanatory and will not be commented on in detail. However, it does contain within each of the stages in the process a few points that may not be self-evident from the previous discussion of the DSB Study Group model. The following brief paragraphs highlight some of these points.

Select Four Programs. Since the selection of the members of the family should reflect national choices to fund entire developments as much as possible, and not a toughly bargained assignment of responsibilities or arbitrary deal of the cards from a narrowly defined area, it is critical that each weapon or system chosen for collaboration represents an agreed-on common requirement for the participating states, and that it is of interest to the industries of the sponsoring states. The "family" may be chosen from any set of common requirements.

Prepare MOU. The basic agreement on the selection of programs to be developed under the family concept and the broad terms of the collaboration on each should be outlined in a Memorandum of Understanding or a series of MOUs. Since the sponsoring country in each case is likely to be one of the Big Four (UK, FRG, France, US), special attention must be given to providing opportunities for smaller states to share in the development, as they are able and willing to do so, as well as in the

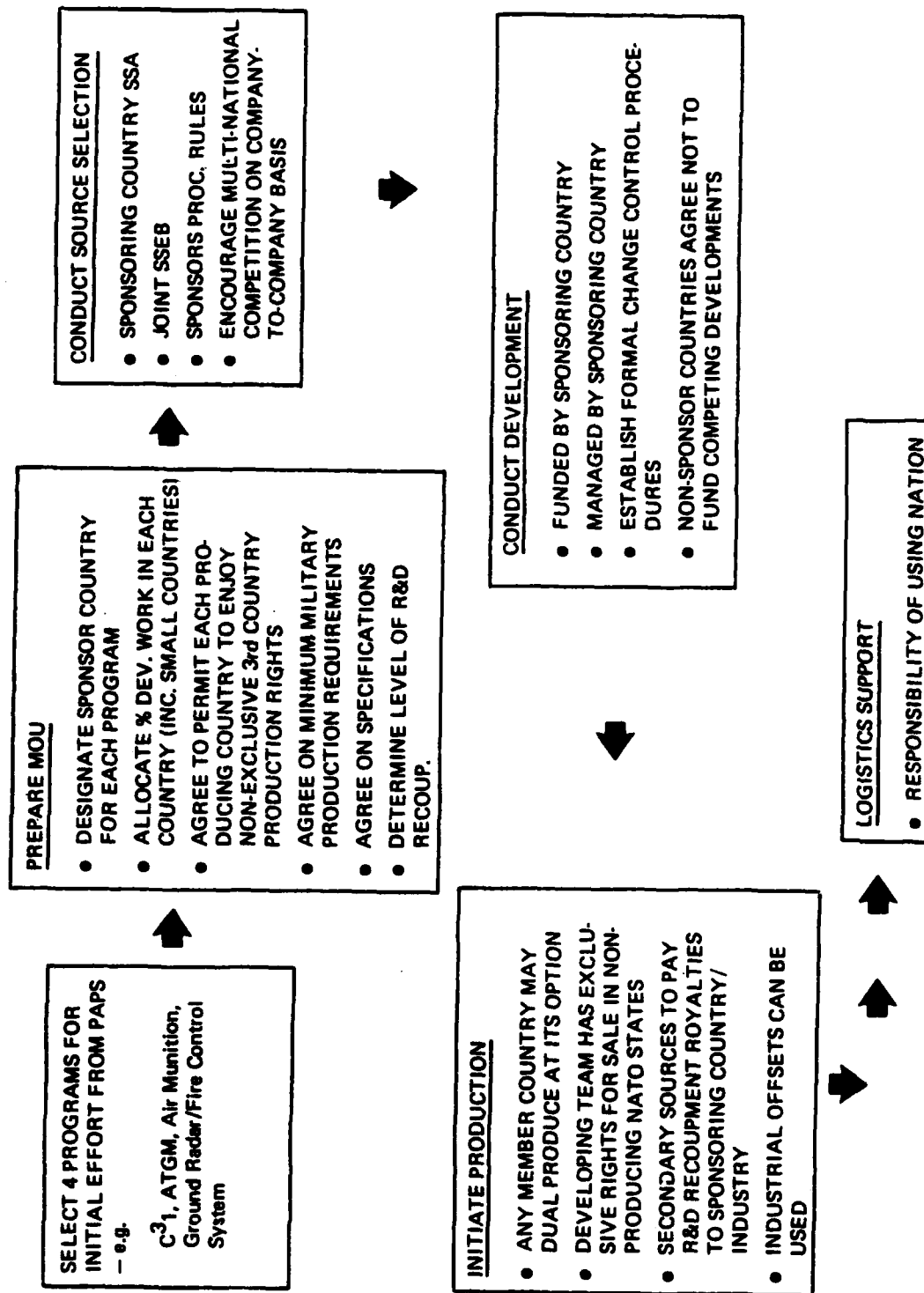

Figure 2 — First Step in "Family of Weapons" Concept

later production. Probably the best way to handle the third country sales issue is to grant each producing country or consortium non-exclusive production rights for sales to extra-NATO third countries; exclusive production rights for sales to NATO countries not participating in production should probably be reserved to the developing country and its production consortium.

Conduct Source Selection. As discussed previously, the development source selection would be the responsibility of the sponsoring country and its Source Selection Agency (SSA). However, a voluntary joint Source Selection Evaluation Board (SSEB) should be set up consisting of representatives from all participating states to advise and assist the sponsoring country SSA. In each case, the sponsor's procurement rules should be used in source selection.

Conduct Development. As in the source selection process, the sponsoring country's procurement rules should be used to manage the development.

Initiate Production. A key point of this approach is to provide multiple production options while rationalizing the Alliance use of development resources. Under this concept, any participating country would have rights to dual produce for its own procurement at its option. If secondary production sources are established, they should be required to pay R&D recoupment costs and royalties to the sponsoring country and its industries. A liberal policy on the use of industrial offsets to facilitate co-production should be followed.

Logistic Support. At the present, logistic support for weapons systems remains principally the responsibility of using nations in NATO.

Summary of DSB Study Group Proposal for a Family of Weapons Concept

The particular advantages of the model of a co-development and co-production approach to the family of weapons concept as proposed by the DSB Study Group are:

- It involves commitment to a common program (or set of programs) by the participation of many nations, yet assigns leadership of each program to a single leader.
- Although control and responsibility for the development are vested in the funding nation, that nation is given both reason to and the means to consider the interest of other participating nations.
- Since co-development and co-production are involved in each program, there is no necessary reason to make a commitment in advance on production; all can wait and see if the development is successful.
- The co-development approach outlined makes high technology available to all the participating members of the Alliance, but it is transferred industrially for acceptable value received.
- The model provides ample opportunity for learning from the process without need to finalize the approach at the initiation of the programs.

Difficulties still remain with the family of weapons concept, even if modified as proposed by the DSB Study Group. Two critical ones are:

- The initial arrangements, which must include several weapons and systems and as many nations as wish to participate, will be difficult to establish.
- Although the modified concept attempts to provide enlarged opportunities for high technology to be made available, by restricting development (or, better, co-development) to one funded program it does not guarantee that the best technology will be used.

OTHER DSB STUDY GROUP RECOMMENDATIONS FOR IMPROVING EFFECTIVENESS

In making the recommendation that DoD emphasize co-development and co-production in its approach(es) to armaments collaboration, the DSB Study Group believes that:

(1) The present DoD program is a start in the direction of better armaments collaboration in NATO that should be built on.

(2) The present DoD program has serious limitations and weaknesses in providing inadequate incentives to both NATO governments and industries to collaborate.

(3) Both Europe and the US are in the midst of a formulative period of re-thinking and reorienting the application of their defense industrial capabilities toward meeting common NATO goals and individual national goals.

(4) In this formulative period, the US and NATO European states should remain open to creative approaches — particularly those proposed by their industries — and not prematurely commit themselves to any one approach that may become doctrinaire.

(5) There are some broad areas of government policies and procedures where immediate changes or improvements can be made to facilitate flexible and adaptable armaments collaboration as a means to improving NATO effectiveness.

(6) There are some critical unresolved issues impeding armaments collaboration, which require the highest policy attention to resolve before armaments collaboration can move very far in new directions.

In regard to the fifth item above, the DSB has provided analyses and recommendations to resolve these issues in the following areas:

- Common defense planning
- Increased emphasis on interoperability
- Improved/modified US procedures and regulations

- Industry involvement in a strategy for co-development and co-production
- Improved approaches to collaboration

Common Defense Planning

Joint Requirements. Ideally, armaments collaboration should proceed from the formulation of joint requirements. Virtually every attempt to adopt another country's development to meet one's own requirement, or adapt one's own development to meet another country's requirement contains difficulties and increases the cost of collaboration. Once requirements have been formulated and accepted on a separate national basis, it is almost too late to begin efficient armaments collaboration. To facilitate formulation of joint requirements as the basis for future armaments collaboration, the DSB Study Group recommends that military staff talks on common doctrine and tactics be strongly supported and endorsed by DoD.

Interoperability. The formulation of joint requirements will have its impact on future capabilities. Improvement in existing capabilities depends on immediate attention to interoperability in NATO as a whole and in the US. From a military point of view, interoperability of fielded forces and equipments could be regarded as an end in itself and standardization, as a means to that end. The DSB Study Group supports and commends the attention that SHAPE and the JCS have given to establishing priorities for interoperability and recommends that DoD give immediate programmatic emphasis to them in its program of armaments collaboration.

Standardization Agreements (STANAGs). The Military Agency for Standardization (MAS) of the Military Committee has published and promulgated some 600 STANAGs over the years, which have been developed and negotiated through many working groups and committees on both the military and the civilian sides of NATO. The materiel STANAGs (about half of the total) form an important basis for achieving degrees of both standardization and interoperability of NATO equipments. The DSB Study Group

believes that, if STANAGs are worth the trouble to negotiate, there should be greater provision for stressing their importance in common defense planning. In particular, reasonable schedules for their implementation should be agreed to as part of their negotiation and means should be established to monitor compliance with them.

Equipment Replacement Schedules. Efficient armaments collaboration on specific programs, especially if any joint funding of co-development is contemplated therein, and the formulation of joint requirements depend on the reasonable coordination of equipment replacement schedules. There are, of course, many difficulties in coordinating equipment replacement schedules as there are in formulating joint requirements. However, planned inventory lives of specific systems and planned initial operational capabilities (IOCs) for new systems are frequently changed for purely national reasons. The DSB Study Group believes that in some circumstances it is worth the effort or cost to adjust both of these for the sake of improved NATO effectiveness through armaments collaboration. The DSB Study Group therefore recommends that DoD give increased support to the development of PAPS within NATO to facilitate coordination of equipment replacement schedules. It should be recognized, however, that while PAPS is necessary, it is not sufficient. As with the formulation of joint requirements, bilateral talks and negotiations with allies with whom armaments compatibility is most important for NATO effectiveness will also be necessary.

Increased US Emphasis on Interoperability

The DSB Study Group does not accept a sharp dichotomy between standardization and interoperability. Interoperability requires a degree of standardization and is sometimes described as standardization from the bottom up. Standardization (even from the top down) aims at and implies interoperability of equipments and forces. Nonetheless, there has been some tendency to see standardization and interoperability as differences of kind more than differences of degree and to regard the US as pressing for NATO-wide standardization to the neglect of

interoperability or to the potential disadvantage of European NATO allies and their industries.

The DSB Study Group believes that a US program of armaments collaboration to improve NATO effectiveness should give at least equal weight to interoperability as to standardization as these terms are formally defined in NATO. This would require increasing the emphasis on interoperability in present US policy statements and in the systems acquisition process.

Policy on Established NATO and JCS Priority Areas. As a policy matter, DoD should make clear that it accepts and emphasizes the established NATO and JCS priority areas for interoperability. These are:

- Command, control, communications
- Cross-servicing of aircraft
- Ammunition
- Battlefield surveillance and target acquisition and designation
- Components and spare parts

Implications for Systems Acquisition Process. To give meaning and force to this emphasis in policy, interoperability must also receive increased emphasis in the systems acquisition process. It is necessary, that the specific requirement for interoperability be written into required operational capability (ROC) statements and requests for proposal (RFPs) as well as into development contracts. The concern for NATO-wide interoperability should also be made more explicit and focused in all Service System Acquisition Review Council (SSARC) and Defense System Acquisition Review Council (DSARC) milestones and reviews. Finally, operational tests and evaluations of systems under development should be required to include a demonstration or certification of NATO interoperability.

An Interoperability Action Plan. Further to give concreteness and emphasis on interoperability along the lines of the established NATO and JCS priority areas, DoD should develop an action plan to implement this interoperability emphasis.

Improved/Modified US Procedures and Regulations

In addition to the specific suggestions made above for improving common defense planning and increasing the emphasis on interoperability, the DSB Study Group recommends that certain general US procedures and regulations be improved or modified to facilitate armaments collaboration.

Guidelines and Rules for Teaming. Although US industry does not wish to be encumbered or hampered in its negotiations with European industry by complex and restrictive rules, some minimum and consistent guidelines and rules are necessary to give industry a framework for negotiating with confidence that teaming arrangements entered into will be acceptable and supported by the US Government.

Information Release Cycle. Efforts need to be undertaken to review the categories of information that can be released under different stages of collaboration and to shorten the approval cycles at each stage. Opportunities for transatlantic collaboration, in particular, will be lost without significant improvement in these procedures.

Release of Performance Data. To facilitate armaments collaboration on systems currently under development, much more forthcoming procedures for release of performance data must be developed.

Release of EW Vulnerability Data. Armaments collaboration among NATO Allies is exceedingly difficult without shared knowledge of and agreement on EW vulnerability. Clearly a tradeoff of military significance is involved here more than in the general area of performance data. DoD must give increased attention to this tradeoff and make better

provision for timely release of EW vulnerability data in those areas where standardization and interoperability are deemed most important.

Contract Terms and Conditions in International Procurement. The Armed Service Procurement Regulations (ASPRs) should be reviewed and modified to provide waivers of peculiarly US terms and conditions or the substitution of European terms and conditions in US procurement contracts. As much as possible, international procurements should respect and use the regulations of the collaborating governments.

Focused Guidance in RFPs, Including Data Rights. Virtually any development conducted by industry involves background data, which are company owned and regarded as what makes the company competitive, as well as foreground data, which are paid for directly by the development contract. Most European governments allow their contractors to own foreground rights also. To ask US industries to be prepared in advance to surrender or to sell all data rights appears to be unnecessary and unreasonable. More focused guidance on all collaborative issues in RFPs is needed, but especially on the question of data rights.

Interpretation of Anti-Trust Laws. Before international agreements on defense market sharing are entered into and industrial firms are committed to their provisions, DoD should seek Justice Department interpretations of anti-trust laws to ensure that the agreements are acceptable under them.

OMB Circular A-109. Circular A-109 recently issued by the Office of Management and Budget essentially provides for an acquisition system that postpones commitment on procurement until development has been completely worked out and judged successful and to be the best available in meeting the mission element need statement (MENS). Since A-109 is less appropriate for a European environment and for an environment of armaments collaboration that depends on early and long term commitment

to agreed requirements and procurement of the systems under development, the DSB Study Group recommends that A-109 be reviewed and modified to allow for earlier decision making with NATO Allies on armaments collaboration programs.

Other Ways to Provide Long Term Commitments. Europeans, with a long history of intra-European collaboration on development as well as production of armaments, have come to count on long term commitments to joint programs. Formally, with annual budget cycles and Congressional authorizations and appropriations, the US system does not provide for long term commitments to (as distinct from planning for) any acquisitions. Acquisitions are legally determined on an annual cycle. Europeans are sensitive to this issue and wary of entering into apparently long term commitments that could be cancelled or unfulfilled. DoD should study and discuss with the Congress ways to provide longer term formal commitments on armaments collaboration to NATO allies.

Industry Involvement in a Strategy for Co-Development and Co-Production

From its discussions with management and technology representatives of US industry, the DSB Study Group believes that there must be a more sustained and systematic dialogue between the US Government and industry that yields a better industry involvement in a strategy for co-development and co-production as the thrust of armaments collaboration to achieve standardization.

Some of the things that could improve industry motivation and sustain industry involvement are:

- Structuring incentives into RFPs and evaluation criteria
- Ensuring profitability in technology transfer
- Allowing partial recovery of costs of exploring opportunities for cooperation
- Communicating policy and program effectively and unambiguously to industry

Improved Approaches to Collaboration

Armaments collaboration, like military trade between the US and Europe, has to become more of a two-way street if it is to function across the Atlantic. The following comments and suggestions are oriented principally to the need for progressing responsively to evolutionary European policies, programs and interests in armaments collaboration.

Avoid Commitments to a Single Overall Approach. No one overall US approach to armaments collaboration can be developed to encompass all cases because:

- The needs and capabilities of European NATO allies vary greatly with respect to armaments collaboration
- Many European industries remain fearful and suspicious of US industrial domination
- Europeans are not unanimous in their approaches to armaments collaboration
- European states have strong technological and development capabilities in particular areas which match or exceed US capabilities

Define Objectives of Armaments Collaboration and Develop a Concept for Achieving Them.

Consider a Variety of Approaches. In any particular case, the approach to be followed should take account especially of:

- The realities of domestic and export markets and export market needs of the participants
- The specialized or unique technological capabilities available or required
- Differing national policies and economic-industrial needs and priorities

Start with Specific Programs. If armaments collaboration is to achieve the goal of improving NATO effectiveness, it is important to get the process started with a few realistic programs with a high prospect of success. In the long run, better armaments collaboration

will come about as an evolutionary and not a revolutionary process. The proper institutional and governmental framework and guidance for this process will come best from experience.

KEY ISSUES

The DSB Study Group identified several key issues of armaments collaboration that pose policy problems involving other agencies of the US Government besides the Department of Defense. Most of the issues concern other US interests and policies that complicate and constrain armaments collaboration within NATO or would themselves be complicated or constrained by a major push for increased armaments collaboration. Such issues fall broadly into three areas: military, political, and economic. The DSB Study Group strongly recommends that these issues be addressed and resolved at the appropriate levels of the US Government so that DoD policies and programs for NATO armaments collaboration may be developed smoothly and consistently with the national interest.

Military

The principal military issue that needs resolution concerns the potential conflict between worldwide US commitments and US NATO commitments.

Differences in Systems Requirements. US general purpose forces are generally structured and equipped to meet either type of commitment, and the US system acquisition process for these forces is geared to this double commitment. However, if and where US requirements for specific types of systems for NATO use or for worldwide use cannot be reconciled, the US may be confronted with the choice of standardizing within NATO and destandardizing within its own general purpose forces or standardizing within US general purpose forces and destandardizing within NATO.

Differences in Equipment Specifications. The physical environment of the Middle East and Central Europe differ radically as well as the tactics and doctrine that may be employed in them. Hence, US equipment specifications for helicopters, for example, provide for different climb rates, operating temperature ranges, safety and survivability parameters than do NATO European equipment specifications.

Vulnerability of Production Base. The use of non-US suppliers for components or subsystems in co-production programs or of non-US suppliers in military trade poses a potential problem for US worldwide commitments. Clearly a European production base on which the US was solely dependent for some of its procurement would be highly vulnerable in wartime to disruption or attack and in peacetime to political constraints.

Political

Forum(s) for Armaments Collaboration. The multiplicity of forums for armaments collaboration within the formal NATO structure and outside it has been commented on above. For realistic and near term armaments collaboration, the US tends principally to use bilateral negotiations and the Four Power forum. It is unclear to the DSB Study Group whether this helps or hinders the stated, longer term desire for a stronger Western Europe and European industrial base. To encourage the latter, there was some sentiment in the DSB Study Group for dealing only with the IEPG. But it is far from clear whether this would be effective or put far too much strain on an embryonic institution.

Extra-NATO Arms Sales. US arms export policy as currently stated and interpreted is likely to make European defense industries and states more reluctant to enter into trans-Atlantic armaments collaborations in the future unless some relief can be found from the third-party restrictions. The DSB Study Group recommends that steps be taken to seek such relief and to clarify and minimize the restraint imposed on NATO Allies by US self restraint.

Long Term Program Commitments. With smaller total R&D funds allocated and sometimes higher development costs for co-development, European governments and parliaments feel they can afford to make only very few false starts. Unless the Congress and the President can find ways to provide more credible long term program commitments, trans-Atlantic armaments collaboration will tend to be second best choices for many European governments in comparison to intra-European collaborations.

Economic

There are no stated US goals related to armaments collaboration pertaining to the strength of the US economy, jobs for US industry, or commercial trade. Armaments collaboration is likely to have an impact, which is neither very well understood nor predictable, in such economic areas. The possible impact of armaments collaboration on the US economy is particularly hard to decipher because it is extremely difficult to determine what circumstances to compare the economics of collaboration against. The DSB Study Group believes that this subject requires continuing and critical review.

The DSB Study Group calls attention, in particular, to one frequently overlooked aspect of this problem. That is the possible significance of military technology transfer. Within the DSB Study Group, there were widely varied judgments on this issue: some fearing that a liberal military technology transfer policy in armaments collaboration would lead to a progressive weakening of the competitive position and, therefore, health of the US economy in the world and eventually be counterproductive to the military strength of the US and thus of NATO; others feeling that only by a more liberal sharing of US military technology with NATO Europe could Europe and the US be mutually strengthened and that to withhold military technology would be counterproductive to the US by failing to secure US technological superiority (European technology is as energetic and sophisticated as and even superior to US technology in many respects) and by stimulating a protectionist atmosphere.

The DSB Study Group was agreed, however, in regarding technology as playing a crucial role in the health of the US economy. Varied evidence from a Department of Commerce study was adduced to support this point. For example, in an 18 year period from 1957 to 1975, US technology intensive industries showed annual rates of growth almost 1.5 times higher in real output, almost twice as high in employment, and almost 40 percent higher in productivity. Moreover, technology intensive industries contributed to inflation at an annual rate that was only about 60 percent as fast as for all other industries. Finally, the technology intensive industries averaged over \$8 billion in net exports compared to an average of \$4 billion in net imports in all other industries.

Other statistics tend to indicate that the US may be losing some of the technological drive it enjoyed in previous years. Statistics on patents issued to US and other nationals are an example. While US nationals were issued 4 percent fewer patents worldwide in 1975 than in 1963, other nationals obtained 37 percent more patents in the later year. Other nationals were issued 106 percent more patents in 1975 by the US Patent Office than in 1963, while patents obtained within the US by US nationals increased by only 10 percent. Within the US, less than 20 percent of all patents were obtained by foreign nationals in 1963. By 1975 this proportion had grown to over 30 percent.

Statistics also show that only technology intensive and agricultural products have consistently contributed to the favorable side of the balance of trade from 1971 to the present, while non-technology intensive products and raw materials have consistently shown negative balances. In illustrating specific characteristics of the US/West European balance of trade, figures show that while the US has consistently maintained a favorable balance of trade with Western Europe in both military hardware and in all technology-intensive products (\$4 billion in 1976), the unfavorable balance of trade in non-technology intensive products with Europe (-\$3 billion in 1976) has brought the total balance close to zero.

Although US military trade with Western Europe is imbalanced

strongly in the US favor, it is useful to consider US military sales in comparison to all US direct defense expenditures in Europe, most of which derive from stationing US forces there. For example, in 1977, the US direct defense expenditures in Europe were approximately \$3 billion, while Foreign Military Sales to Europe amounted to about \$1 billion. Hence, because of this disparity, the US could be said to have a deficit of close to \$2 billion.

To sum up this aspect of the economic issue, the DSB Study Group is concerned that armaments collaboration not contribute to an erosion of the US technology lead and thus to a weakened US economic posture. Technology transfer in armaments collaboration needs to be handled very carefully. Dual production means total transfer of technology including production technology and, generally, technological improvement. Military technology is used in civilian products to a degree that is not well understood, and production technology for military products can improve commercial production capability. Military technology transfer therefore could weaken the US competitive edge in some segments of the commercial market and contribute to a further weakening of the dollar and the US economy. The DSB Study Group believes that this economic issue merits continuing intense study in an inter-agency context and that the issue should be addressed on a program-by-program basis in DSARC reviews for all armaments collaborations.

In the absence of further evidence about the impact on the economy of military technology transfer, the DSB Study Group supports technology transfer only if the tradeoffs are balanced and:

- It is implemented directly by industry-to-industry negotiations and not primarily by government transfer of data packages.
- It is appropriately compensated in the light of immediate and long-term economic value.
- Industry is consulted in the selection of what is to be traded.
- Government regulations are simplified and the time required for approval is reduced.

Appendix A

STUDY PARTICIPANTS

DSB STUDY GROUP

The DSB members who constituted the Study Group on "Achieving Improved NATO Effectiveness Through Armaments Collaboration" were the following:

Dr. Walter B. LaBerge, Chairman of the Study
Under Secretary of the Army

Mr. Oliver C. Boileau, Vice Chairman of the Study
President
Boeing Aerospace

Dr. Betsy Ancker-Johnson
Associate Director
Argonne National Laboratory

Mr. Norman Augustine
Vice President
Martin Marietta Aerospace

Dr. John Baldeschwieler
Division of Chemistry and Chemical Engineering
California Institute of Technology

Dr. Richard DeLauer
Executive Vice President
TRW

Dr. Charles Herzfeld
Technical Director
ITT Telecommunications and Electronics

Dr. Robert Noyce
Chairman of the Board
Intel Corporation

Dr. George Sebestyen
President
Defense Systems, Inc.

MANAGEMENT REPRESENTATIVES FROM INDUSTRY

The following invited guests from industry spent two or three days each in discussions with DSB members:

Mr. W. Crawford
General Manager
General Electric

Mr. P. Devirian
Vice President
FMC

Mr. W. Hawkins
President
Lockheed-California

Mr. L. Heilig
Vice President
Ford Aerospace

Mr. B. Holmes
President
Raytheon

Mr. R. Johnson
President
McDonnell Douglas Astronautics

Mr. J. Richardson
Executive Vice President
Hughes Aircraft

Dr. J. Shea
Senior Vice President
Raytheon

Mr. T. Stuelpnagel
President
Hughes Helicopters

Mr. J. Stuntz
Vice President, Science and Technology
Westinghouse

Mr. G. Tobias
President
Sikorsky Aircraft

TECHNOLOGY REPRESENTATIVES FROM INDUSTRY

The following invited guests from industry spent one to three days each in discussions with DSB members on problems and prospects for technology sharing and transfer:

Dr. F. Bagby
Director, Advanced Systems Laboratory
Battelle Institute

Mr. F. Cleveland
Vice President for Engineering
Lockheed

Mr. M. Fossier
Vice President and Assistant General Manager (Technical)
Raytheon Missiles System Division

Dr. D. Hicks
Senior Vice President, Technical
Northrop

Dr. P. McManigal
Director, Planning
Ford Aerospace

Mr. R. Race
Ordnance Systems
General Electric

Dr. K. Rosen
Sikorsky Aircraft Division

Dr. J. Sternberg
Director, Advanced Systems
Martin Marietta Aerospace

RAAdm K. Wallace (Ret.)
McDonnell Douglas Astronautics

Mr. T. Wilson
President
Teledyne Ryan Aeronautical

Mr. P. Wright
Division Vice President, Engineering
RCA Government Systems Division

Dr. R. Ying
Hughes Aircraft Company

US GOVERNMENT AND OTHER EXPERTS

The following persons briefed the DSB Study Group members on selected aspects of NATO RSI and armaments collaboration.

MG T. Ahern
Assistant Deputy Chief of Staff for Research,
Development, and Acquisition, USAF

LTG R. Baer
Deputy Commander for Materiel Development
US Army Materiel Development and Readiness Command

Mr. M. Boretsky
Department of Commerce

BG R. Boverie
Assistant Deputy Director of Plans, USAF

MG R. Bowman
Director, NATO Affairs
Office of the Assistant Secretary of Defense/
International Security Affairs

Mr. R. Calaway
Assistant for Program Planning
Office of the Under Secretary of Defense for
Research and Engineering

Mr. T. Callaghan
Center for Strategic and International Studies
Georgetown University

Mr. D. Church
Deputy Under Secretary of Defense for Research and
Engineering/Acquisition Policy

Ms. E. Frost
Deputy Assistant Secretary of Defense for
International Economic Affairs

Dr. V. Garber
Director, International Programs
Office of the Under Secretary of Defense for
Research and Engineering

Mr. R. Gessert
Principal Scientist
General Research Corporation

Mr. J. Goodby
Deputy Assistant Secretary of State/Europe

Dr. R. Hermann
Deputy Under Secretary of Defense for Research
and Engineering/C³I

RAAdm R. Hilton
Director, Strategy, Plans and Policy, USN

RAAdm F. Johnson
Director, Undersea and Strategic Warfare and
Nuclear Energy Development, USN

Ambassador R. Komer
Advisor to the Secretary of Defense/NATO Affairs

RAAdm J. Lyons
Office of the Joint Chiefs of Staff

Dr. J. Martin
Assistant Secretary of the Air Force/Research,
Development and Logistics

GEN D. Starry
Commanding General
US Army Training and Doctrine Command

Dr. J. Walsh
Assistant Secretary General for Defense Support
NATO