

4

NTIS FILE CODE

AD _____

REPORT NO. T20-88

AD-A200 923

QUANTIFICATION OF ENVIRONMENTAL CHAMBERS BY AIR VELOCITY MAPPING

U S ARMY RESEARCH INSTITUTE
OF
ENVIRONMENTAL MEDICINE
Natick, Massachusetts

DTIC
ELECTE
OCT 3 1 1988
S D
D C

SEPTEMBER 1988



Approved for public release. distribution unlimited

UNITED STATES ARMY
MEDICAL RESEARCH & DEVELOPMENT COMMAND

The findings in this report are not to be construed as an official Department of the Army position, unless so designated by other authorized documents.

DISPOSITION INSTRUCTIONS

Destroy this report when no longer needed.

Do not return to the originator.

UNCLASSIFIED

SECURITY CLASSIFICATION OF THIS PAGE

REPORT DOCUMENTATION PAGE				Form Approved OMB No. 0704-0188	
1a. REPORT SECURITY CLASSIFICATION Unclassified			1b. RESTRICTIVE MARKINGS		
2a. SECURITY CLASSIFICATION AUTHORITY			3. DISTRIBUTION / AVAILABILITY OF REPORT Approved for public release; distribution is unlimited		
2b. DECLASSIFICATION / DOWNGRADING SCHEDULE					
4. PERFORMING ORGANIZATION REPORT NUMBER(S)			5. MONITORING ORGANIZATION REPORT NUMBER(S)		
6a. NAME OF PERFORMING ORGANIZATION U.S. Army Rsch Inst of Env Med		6b. OFFICE SYMBOL (If applicable) SGRD-UE-MEB	7a. NAME OF MONITORING ORGANIZATION U.S. Army Rsch Inst of Env Med		
6c. ADDRESS (City, State, and ZIP Code) Natick, MA 01760-5007			7b. ADDRESS (City, State, and ZIP Code) Natick, MA 01760-5007		
8a. NAME OF FUNDING / SPONSORING ORGANIZATION Same as 6a.		8b. OFFICE SYMBOL (If applicable)	9. PROCUREMENT INSTRUMENT IDENTIFICATION NUMBER		
8c. ADDRESS (City, State, and ZIP Code) Same as 6c.			10. SOURCE OF FUNDING NUMBERS	PROGRAM ELEMENT NO.	PROJECT NO. 3E1627 87A878 ✓
				TASK NO. 878/AE	WORK UNIT ACCESSION NO. 083
11. TITLE (Include Security Classification)(U)Quantification of Environmental Chambers by Air Velocity Mapping					
12. PERSONAL AUTHOR(S) Stephen KW. Chang, MSEE., Ph.D. and Richard R. Gonzalez, Ph.D.					
13a. TYPE OF REPORT Technical Report		13b. TIME COVERED FROM _____ TO _____		14. DATE OF REPORT (Year, Month, Day) 1988	15. PAGE COUNT 25
16. SUPPLEMENTARY NOTATION					
17. COSATI CODES			18. SUBJECT TERMS (Continue on reverse if necessary and identify by block number) air velocity map; environmental chambers; wind speed measurement. (SDU) ←		
FIELD	GROUP	SUB-GROUP			
19. ABSTRACT (Continue on reverse if necessary and identify by block number) The air velocity profile of a U.S. Army Research Institute of Environmental Medicine (USARIEM) test chamber was mapped using an anemometer tree system. This particular chamber houses an articulated copper manikin. It was found that the air velocity within the chamber is a disparate property. Airflow patterns are significantly different at different chamber fan speed settings, and the practice of employing a single thermal or cup anemometer to monitor chamber air velocity, in general, is inadequate. It is recommended that the air velocity profile of a given test chamber should be mapped by techniques described in this report, for all protocol studies in which air velocity data are important, such as clothing insulation evaluation and convective heat transfer studies. <i>Keywords...</i>					
20. DISTRIBUTION / AVAILABILITY OF ABSTRACT <input checked="" type="checkbox"/> UNCLASSIFIED/UNLIMITED <input type="checkbox"/> SAME AS RPT. <input type="checkbox"/> DTIC USERS			21. ABSTRACT SECURITY CLASSIFICATION Unclassified		
22a. NAME OF RESPONSIBLE INDIVIDUAL Stephen KW. Chang, Ph.D.			22b. TELEPHONE (Include Area Code) 508/651-4817	22c. OFFICE SYMBOL SGRD-UE-MEB	

DD Form 1473, JUN 86

Previous editions are obsolete.

SECURITY CLASSIFICATION OF THIS PAGE
UNCLASSIFIED

The views, opinions, and/or findings contained in this report are those of the authors and should not be construed as an official Department of the Army position, policy, or decision, unless so designated by other official documentation.



Accession For	
NTIS CRA&I	<input checked="" type="checkbox"/>
DTIC TAB	<input type="checkbox"/>
Unannounced	<input type="checkbox"/>
Justification	
By	
Distribution /	
Availability Codes	
ORR	Avail and/or Special
A-1	

AD

TECHNICAL REPORT

NO.

QUANTIFICATION OF ENVIRONMENTAL CHAMBERS
BY AIR VELOCITY MAPPING

by

Stephen KW. Chang, MSEE., Ph.D. and Richard R. Gonzalez, Ph.D.

U. S. Army Research Institute of Environmental Medicine
Natick, MA 01760-5007

TABLE OF CONTENTS

	Page
ABSTRACT	v
INTRODUCTION	1
METHOD	1
RESULTS	3
DISCUSSION	4
CONCLUSION	6
TABLES	7
FIGURES	11
APPENDIX	21

ABSTRACT

The air velocity profile of a U. S. Army Research Institute of Environmental Medicine (USARIEM) test chamber was mapped using an anemometer tree system. This particular chamber houses an articulated copper manikin. It was found that the air velocity within the chamber is a disparate property. Airflow patterns are significantly different at different chamber fan speed settings, and the practice of employing a single thermal or cup anemometer to monitor chamber air velocity, in general, is inadequate. It is recommended that the air velocity profile of a given test chamber should be mapped by techniques described in this report, for all protocol studies in which air velocity data are important, such as clothing insulation evaluation and convective heat transfer studies.

INTRODUCTION

Selection of proper clothing has an important influence on the performance of military personnel. Biophysical models which allow prediction of clothing performance under field conditions can be a valuable tool for development and validation. However, all models are limited by the accuracy of the available test data. Since environmental chambers provide proper control for simulation of field conditions, they are often relied upon to provide the initial data for development and the final data for validation.

In clothing performance evaluation, the convective heat exchange is a critical variable, and accurate air velocity data are necessary. Currently, air velocity profiles within a test chamber are, in general, not available. In many test chambers, the airflow is assumed to be uniform throughout. A single thermal or cup anemometer is used to monitor the air velocity for the entire chamber. This present study reports on a technique to validate the air velocity scenarios. A fast responding multi-anemometer system (TSI anemometer tree, see Figure 1) was used to map the air velocity profile of one USARIEM chamber, which houses an articulated copper manikin.

METHOD

The test chamber was cleared of all articles except the articulated manikin and its supporting frame. The chamber temperature was set at 27° C. Chamber fan speeds were set to 20%, 40%, 60% and 80% of maximum fan speed. These four settings provided chamber air velocity ranges between 0.2 m/s to 2.5 m/s. On the anemometer tree stack, six omni-directional thermal anemometers were positioned, each at a different height level. The distance between each anemometer probe was 30 cm, with the lowest probe 30 cm above the chamber

floor. The highest probe was, therefore, 180 cm above ground. The 30 cm and 180 cm levels corresponded approximately to the ankle and the head positions, respectively, of the articulated manikin.

Figure 2 shows the placements (O) of the anemometer tree within the chamber. In Figure 2, the row designation of A, B, C, D, and E and the column number 1, 2, 3, 4, and 5 help to identify each tree placement location. The anemometer tree was first placed at the A1 location in the chamber. Chamber fan speed was set to 20% and air velocity measured. The chamber fan speed was then increased to the next level for the next measurement. After all four wind speeds (20%, 40%, 60%, and 80%) were completed, the anemometer tree was then moved to another location, to begin another round of measurement. The sequence of anemometer tree placement was A1, A2, A3, A4, A5, B1, B2, ... B5, C1, ... C5, D1, ... D5, E1, ... E5.

Wind speed was measured using a portable (COMPAQ) computer. The thermal anemometer signal was converted through a analog-to-digital (A/D) converter, to digital data. The digital data were then sampled and stored in the computer. Figure 3 shows a schematic diagram of the signal/data path. At each tree location, for each chamber fan speed setting, the anemometer data were collected continuously over a thirty minute period. The measured air velocity shown in Tables 1-4 represent the average of the 30 minute period. With twenty-five tree placements, each at four different chamber wind speeds, a total of 100 sets of air velocity profile data were collected.

RESULTS

The entire set of the measured anemometer data are included as Tables 1 through 4. Tables 1, 2, 3 and 4 contain, respectively, the air velocity data at

20%, 40%, 60% and 80% of maximum chamber fan speed. The anemometer tree locations are designated using row A, B, C, D, and E, and column 1, 2, 3, 4, and 5 (refer to Figure 2). The air velocity profiles are plotted in three dimensional maps, shown in Figures 5 through 10. Figure 4 is used as an example to explain the map schematics. The chamber floor is represented by a rectangle. Direction of airflow is from right to left. On the chamber floor, each anemometer tree placement location is designated by a '+' symbol. The human figure represents the position of the articulated manikin. The manikin is deleted in most plots to provide a clearer background for the air velocity map. The level label (120 cm) indicates the height level of the anemometers. The air velocity data are mapped in a grid plot. The grid in Figure 4 represents the air velocity map from anemometer measurement at the 60 cm level (at 80% fan speed). If the air velocity of a particular level is fairly uniform, then a flat grid is the result. An uneven grid map indicates large variations in the air velocity pattern. The maximum and minimum air velocity values for the data set represented in the grid are also displayed to show the range. The two digit number at the upper right hand corner gives the fan speed and anemometer level. The first digit, range 1 to 4, gives the fan speed: 1 = 20%, 2 = 40%, 3 = 60%, and 4 = 80% of maximum chamber fan speed. The second digit, range 1 to 6, indicates the anemometer level: 1 = 30 cm, 2 = 60 cm, ... 6 = 180 cm. The anemometer level is, of course, already explicitly displayed.

Figures 5 - 10 display the full set of air velocity data contained in Tables 1 - 4. Each of the six figures represent one anemometer height level. Within each figure, four plots <a>, , <c>, and <d> are derived from the four fan speed settings 20%, 40%, 60%, and 80%, respectively.

The computer algorithm used to produce the simulated three dimensional air velocity map is included as Appendix. The program was written using QuickBASIC Compiler (version 4.0). It can be easily converted to run on a BASIC interpreter.

DISCUSSION

Several observations can be made from Figures 5 - 10. One immediately apparent is that the variation in air velocity was much more pronounced at higher fan speed than at lower fan speed. Plots <a> in Figures 5-10 show at 20% fan speed, air velocity was nearly uniform throughout the chamber, at all height levels. It should be mentioned that the 20% fan speed is the minimal air circulation required to maintain chamber temperature regulation. In contrast, plots <d> of Figures 5-10 displayed large variation in air velocity when 80% chamber fan speed was employed.

The second observation is that, as expected, structures within the chamber alter significantly the airflow pattern. This includes all test equipment used in the chamber and other built-in structures and constructions within the chamber. In this particular testing chamber, the articulated manikin and its supporting frame are the most prominent structures. In Figure 8, at 120 cm, it can be seen that air velocity decreased not only behind but also in front of the manikin. In comparison to Figure 10, where the anemometer height (180 cm) was slightly above the head of the manikin, interference of the airflow was much less noticeable.

There were also variations in the air velocity maps which are not as easily explained. In Figure 9, plot <d>, aside from the well around the manikin, there were two other dips in the air velocity grid: at positions B2 and D3 (refer to

Figure 2 for position designation). Also, dips at positions B2 and E2 in Figure 8<d>, and at positions B2 and D4 in Figure 7<d>, were evident. These decreases might be caused by the manikin supporting frame, although the evidence is not conclusive. If the supporting frame were the culprit, symmetrical effect should have been found, i.e., the dip at B2 should couple with another dip at D2, since the frame is symmetrical about the manikin. No symmetry was evident, and no conclusion can be made. Nevertheless, these variations must be accepted as inherent to the particular chamber construction, and their effects must be properly considered when using any given chamber.

In a recent study in another environmental chamber, the USARIEM High Elevation Simulation Facility (altitude chamber), the authors noticed that not only does the chamber exhibit a characteristic airflow pattern but also variants in airflow can be attributed to different simulated elevations. For example, during the ascending and descending phases, the airflow showed marked variation during a transient period before slowly stabilizing to a new characteristic pattern of the new chamber environment.

It seems clear that no environmental chamber should be assumed to exhibit a laminar or uniform flow pattern. Each individual chamber has its own inherent air velocity profile, perhaps due to its construction, and the profile invariably changes as the chamber condition is altered. The standardized technique described in this report could be easily employed prior to or along with specific studies requiring precise estimation of heat transfer coefficients attributed to airflow variations.

CONCLUSION

The USARIEM articulated manikin chamber air velocity profile was mapped using an anemometer tree system. It was found that the air velocity within the chamber is far from uniform, and the airflow patterns can be significantly different at different chamber fan speed setting. As expected, equipment and structure within the chamber do alter the airflow pattern. Furthermore, there are also variations in the airflow which are apparently inherent to the chamber construction itself, but can not otherwise be explained. The assumption of uniform airflow within a chamber is inaccurate and the practice of employing a single anemometer to monitor the chamber air velocity is inadequate. It is recommended that an air velocity profile of given chamber should be mapped for all protocol studies in which air velocity and/or precise heat transfer coefficients are important.

Table 1 Air velocity data (m/s) at 20% maximum fan speed
refer to Figure 2 for anemometer location designation

20% maximum fan speed

<u>Anemometer Probe Height</u>						<u>Anemometer Location</u>
180cm	150cm	120cm	90cm	60cm	30cm	
0.226	0.239	0.264	0.235	0.295	0.274	A1
0.274	0.264	0.343	0.314	0.375	0.327	A2
0.287	0.286	0.349	0.348	0.346	0.348	A3
0.302	0.246	0.336	0.325	0.366	0.317	A4
0.258	0.272	0.322	0.350	0.336	0.364	A5
0.325	0.254	0.349	0.339	0.361	0.334	B1
0.287	0.151	0.238	0.164	0.287	0.229	B2
0.183	0.126	0.249	0.205	0.311	0.264	B3
0.225	0.169	0.184	0.245	0.295	0.265	B4
0.201	0.194	0.113	0.187	0.241	0.260	B5
0.307	0.246	0.302	0.247	0.288	0.215	C1
0.298	0.241	0.285	0.234	0.286	0.199	C2
0.252	0.250	0.304	0.301	0.340	0.249	C3
0.237	0.148	0.216	0.208	0.280	0.210	C4
0.178	0.110	0.070	0.210	0.163	0.221	C5
0.258	0.270	0.305	0.291	0.303	0.305	D1
0.283	0.207	0.242	0.180	0.262	0.229	D2
0.268	0.060	0.249	0.105	0.107	0.100	D3
0.205	0.177	0.185	0.095	0.105	0.148	D4
0.256	0.089	0.165	0.166	0.166	0.167	D5
0.163	0.169	0.194	0.230	0.321	0.357	E1
0.172	0.183	0.231	0.313	0.409	0.428	E2
0.259	0.342	0.402	0.406	0.385	0.408	E3
0.257	0.387	0.385	0.299	0.263	0.262	E4
0.288	0.288	0.284	0.262	0.227	0.217	E5

Table 2 Air velocity data (m/s) at 40% maximum fan speed
refer to Figure 2 for anemometer location designation

40% maximum fan speed

<u>Anemometer Probe Height</u>						<u>Anemometer Location</u>
180cm	150cm	120cm	90cm	60cm	30cm	
0.609	0.579	0.670	0.550	0.818	0.671	A1
0.737	0.689	0.876	0.798	0.969	0.847	A2
0.765	0.658	0.883	0.837	0.942	0.821	A3
0.796	0.646	0.867	0.836	0.918	0.812	A4
0.748	0.624	0.799	0.804	0.816	0.802	A5
0.768	0.535	0.825	0.722	0.878	0.645	B1
0.715	0.391	0.527	0.365	0.661	0.504	B2
0.539	0.279	0.619	0.497	0.787	0.599	B3
0.430	0.345	0.381	0.462	0.758	0.540	B4
0.415	0.495	0.274	0.490	0.583	0.551	B5
0.756	0.592	0.705	0.615	0.833	0.526	C1
0.760	0.681	0.653	0.626	0.922	0.585	C2
0.762	0.411	0.693	0.719	0.906	0.560	C3
0.584	0.370	0.480	0.542	0.752	0.495	C4
0.432	0.195	0.211	0.479	0.391	0.503	C5
0.649	0.627	0.707	0.611	0.823	0.731	D1
0.800	0.590	0.657	0.557	0.686	0.576	D2
0.660	0.188	0.608	0.367	0.638	0.270	D3
0.613	0.310	0.461	0.307	0.496	0.413	D4
0.584	0.307	0.514	0.483	0.563	0.498	D5
0.376	0.501	0.420	0.407	0.555	0.519	E1
0.486	0.506	0.371	0.351	0.507	0.544	E2
0.596	0.780	0.664	0.548	0.723	0.811	E3
0.528	0.980	0.880	0.729	0.744	0.760	E4
0.554	0.834	0.808	0.669	0.649	0.627	E5

Table 3 Air velocity data (m/s) at 60% maximum fan speed
refer to Figure 2 for anemometer location designation

60% maximum fan speed

<u>Anemometer Probe Height</u>						<u>Anemometer Location</u>
<u>180cm</u>	<u>150cm</u>	<u>120cm</u>	<u>90cm</u>	<u>60cm</u>	<u>30cm</u>	
1.262	1.096	1.255	1.063	1.625	1.245	A1
1.513	1.365	1.655	1.553	1.896	1.539	A2
1.556	1.303	1.676	1.630	1.789	1.515	A3
1.546	1.324	1.658	1.621	1.707	1.451	A4
1.366	1.258	1.553	1.533	1.458	1.408	A5
1.402	0.996	1.547	1.301	1.579	1.139	B1
1.452	0.724	1.004	0.698	1.264	0.965	B2
1.094	0.558	1.223	1.049	1.602	1.098	B3
0.849	0.740	0.696	0.920	1.562	1.001	B4
0.698	0.978	0.489	0.974	1.127	0.974	B5
1.530	1.229	1.360	1.242	1.760	1.057	C1
1.597	1.395	1.288	1.253	1.909	1.185	C2
1.531	0.799	1.379	1.410	1.712	1.048	C3
1.107	0.642	0.956	1.028	1.451	0.862	C4
0.852	0.379	0.359	0.911	0.805	0.934	C5
1.280	1.251	1.320	1.282	1.470	1.281	D1
1.628	1.276	1.288	1.185	1.309	1.115	D2
1.378	0.358	1.214	0.759	1.304	0.575	D3
1.275	0.574	0.883	0.630	1.029	0.863	D4
1.133	0.532	0.989	0.884	1.082	0.942	D5
0.591	0.764	0.659	0.614	0.960	0.811	E1
0.699	0.721	0.595	0.531	0.740	0.718	E2
1.034	1.210	1.080	0.853	1.017	1.140	E3
0.837	1.536	1.444	1.132	1.197	1.297	E4
0.924	1.599	1.514	1.233	1.162	1.174	E5

Table 4 Air velocity data (m/s) at 80% maximum fan speed
refer to Figure 2 for anemometer location designation

80% maximum fan speed

Anemometer Probe Height						Anemometer Location
180cm	150cm	120cm	90cm	60cm	30cm	
1.945	1.592	1.845	1.590	2.394	1.766	A1
2.299	2.032	2.400	2.287	2.804	2.170	A2
2.287	2.047	2.431	2.406	2.625	2.026	A3
2.210	2.019	2.359	2.360	2.395	1.981	A4
1.969	1.938	2.305	2.263	2.048	1.933	A5
2.087	1.548	2.295	1.879	2.293	1.609	B1
2.227	1.067	1.470	1.041	1.856	1.418	B2
1.711	0.845	1.852	1.623	2.359	1.590	B3
1.288	1.147	1.039	1.463	2.412	1.383	B4
0.975	1.456	0.734	1.512	1.665	1.291	B5
2.327	1.880	2.042	1.880	2.569	1.589	C1
2.467	2.130	2.086	1.965	2.832	1.842	C2
2.329	1.264	2.163	2.131	2.576	1.579	C3
1.556	0.943	1.524	1.574	2.229	1.305	C4
1.274	0.536	0.519	1.429	1.224	1.371	C5
1.974	1.971	1.996	1.972	2.054	1.810	D1
2.460	2.005	1.961	1.752	1.844	1.650	D2
2.166	0.545	1.884	1.205	1.928	0.837	D3
1.918	0.893	1.365	0.993	1.499	1.268	D4
1.630	0.852	1.397	1.301	1.585	1.355	D5
0.786	0.986	0.933	0.812	1.364	1.155	E1
0.962	0.932	0.785	0.737	0.985	1.013	E2
1.499	1.669	1.493	1.148	1.422	1.542	E3
1.137	2.090	1.909	1.517	1.673	1.846	E4
1.375	2.298	2.181	1.756	1.644	1.689	E5

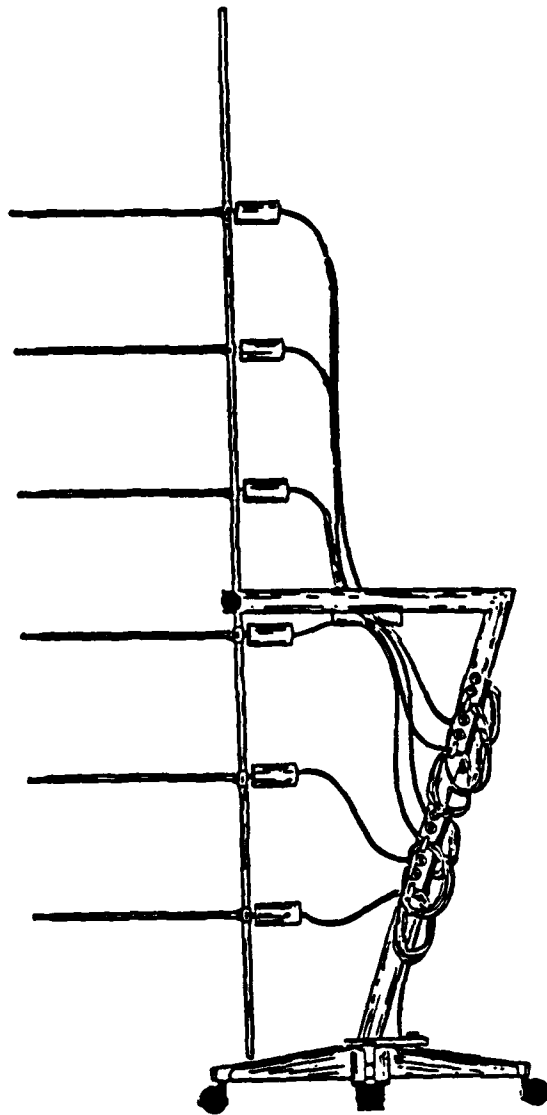

Figure 1 Anemometer tree (modified from TSI contract manual)

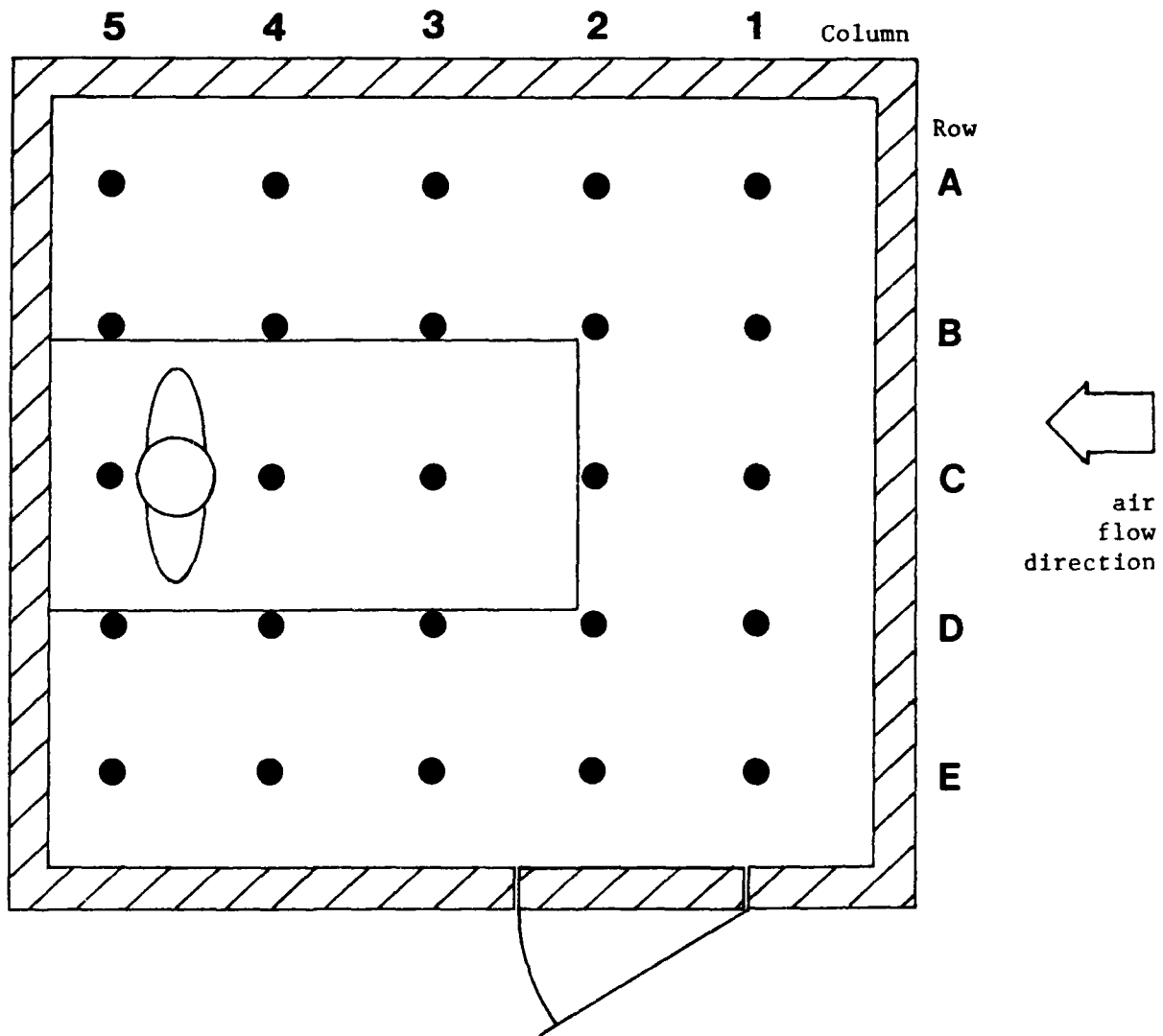

Figure 2 Articulated mannikin chamber schematic diagram with the mannikin and supporting frame anemometer tree placement location (●) direction of air flow is from right to left

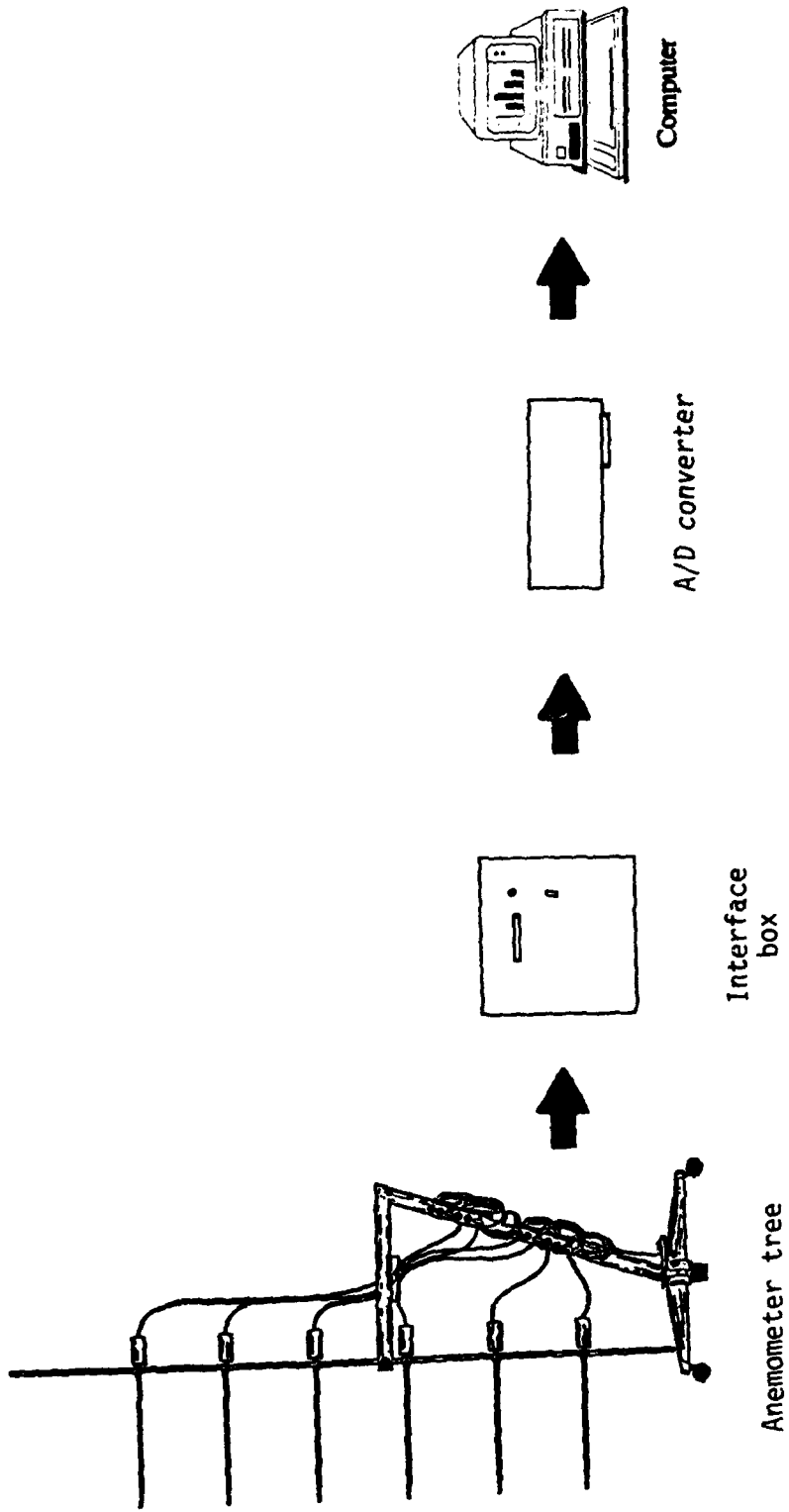

Figure 3 Diagram showing signal/data path from the anemometer tree to the computer

APPENDIX

This program plots a simulated three dimensional air velocity map from data gathered using the Anemometer Tree System in an environmental chamber. The entire data set collected from the articulated manikin chamber are included in this report as Tables 1-4, and are deleted from this program to save space. A few examples of the data set are left to show the input data format. This program is written using QuickBASIC Compiler (version 4.0). It can be converted to run on BASIC Interpreter by adding line numbers, and replacing all the Labels after a GOTO statement with the appropriate line numbers.

```

                                                                    chamber level labels
DATA "180cm", "150cm", "120cm", "90cm", "60cm", "30cm"
.
DATA 1.945, 1.592, 1.845, 1.590, 2.394, 1.766
'DATA . air velocity data
'DATA . (80% fan speed)
'DATA . see data set in Table 4
.
DATA 1.262, 1.096, 1.255, 1.063, 1.625, 1.245
'DATA . air velocity data
'DATA . (60% fan speed)
'DATA . see data set in Table 3
.
DATA 0.609, 0.579, 0.670, 0.550, 0.818, 0.671
'DATA . air velocity data
'DATA . (40% fan speed)
'DATA . see data set in Table 2
.
DATA 0.226, 0.239, 0.264, 0.235, 0.295, 0.274
'DATA . air velocity data
'DATA . (20% fan speed)
'DATA . see data set in Table 1
.
DIM Manp(14944) AS INTEGER ' mannikin plot storage array
DIM Bord(14102) AS INTEGER ' screen border plot storage array
DIM cham(4, 5, 5, 6) AS SINGLE ' air velocity data array
DIM level$(6) ' anemometer level labels
DIM wmax(4, 6), wmin(4, 6) ' max & min air velocity
DIM vx(5, 5), vy(5, 5) AS INTEGER ' air velocity map points
.
SCREEN 9
CLS
.
backgd = 1 ' mannikin background indicator (1=display, 0=no)
.
px = 375: py = 305 ' pset (starting) location
ax = 25: ay = 80 ' turn angle DRAW degrees
lx = 270: ly = 270 ' border DRAW statement values
sx = 50: sy = 55 ' probe location DRAW values
dx = 30: dy = 75 ' wind direction arrow angle DRAW degrees

```

```

CIRCLE (176, 85), 14, . . . , 16 / 15 ' draw mannikin
DRAW "AO BD15" + "TA=" + VARPTR$(ax) + "R31 AO D70"
DRAW "TA=" + VARPTR$(ax) + "L11 AO NU30 D70"
DRAW "TA=" + VARPTR$(ax) + "L20 AO NU60"
DRAW "TA=" + VARPTR$(ax) + "L20 AO U70 NU30"
DRAW "TA=" + VARPTR$(ax) + "L11 AO U70"
DRAW "TA=" + VARPTR$(ax) + "R31"
.
GET (70, 70)-(560, 310), Manp ' SAVE mannikin
.
CLS
PSET (px, py) ' draw probe locations
FOR y = 1 TO 5
  FOR x = 1 TO 5
    DRAW "AO NU2 ND2 NR2 NL2"
    DRAW "TA=" + VARPTR$(ax) + "BR=" + VARPTR$(sx)
  NEXT x
  PSET (px, py): yy = sy * y
  DRAW "TA=" + VARPTR$(ay) + "BU=" + VARPTR$(yy)
NEXT y
.
.
.
PSET (px + 4, py + 15) ' draw border outline
FOR i = 1 TO 8 ' draw front border
  DRAW "TA=" + VARPTR$(ax) + "NR=" + VARPTR$(ix) + "AO BD1"
NEXT i
PSET (px + 4, py + 15) ' right side
DRAW "TA=" + VARPTR$(ax) + "BR=" + VARPTR$(ix)
DRAW "TA=" + VARPTR$(ay) + "U270"
PSET (px + 4, py + 15)
FOR j = 1 TO 8 ' thick y side
  DRAW "TA=" + VARPTR$(ay) + "NU=" + VARPTR$(iy) + "AO BD1"
NEXT j
PSET (px + 4, py + 15) ' back side
DRAW "TA=" + VARPTR$(ay) + "BU=" + VARPTR$(iy)
DRAW "TA=" + VARPTR$(ax) + "R270"
.
dy3 = dy - 3 ' draw wind direction arrow
PSET (px + 192, py + 6)
DRAW "TA=" + VARPTR$(dy) + "U18" + "TA=" + VARPTR$(dx) + "L10"
PSET (px + 192, py + 6)
DRAW "TA=" + VARPTR$(dx) + "R40" + "TA=" + VARPTR$(dy3) + "U21"
DRAW "TA=" + VARPTR$(dx) + "R12 TA90 U37 TA180 U26"
LOCATE 24, 63: PRINT "wind direction";
.
GET (0, 180)-(639, 349), Bord ' save border outline & probe loc.
.
PUT (70, 70), Manp, OR ' put back mannikin
.
FOR z = 6 TO 1 STEP -1
  READ level$(z) ' read in anemometer level labels
NEXT z
.

```

max air = 2.431 m/s
min air = 0.519 m/s

44

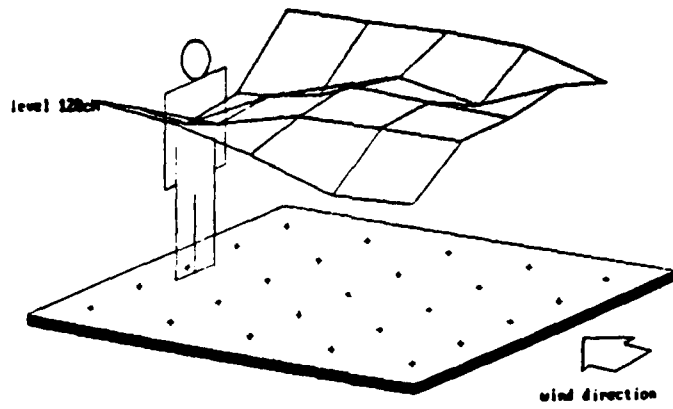

Figure 4 Illustration of air velocity map
(120cm height level)

max air = 2.170 m/s
min air = 0.837 m/s

41

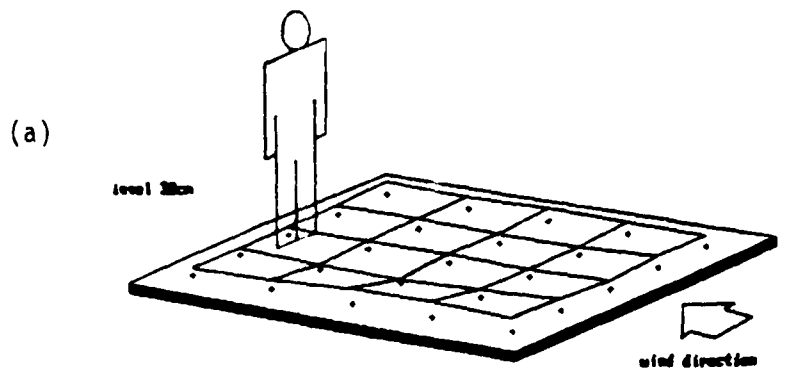
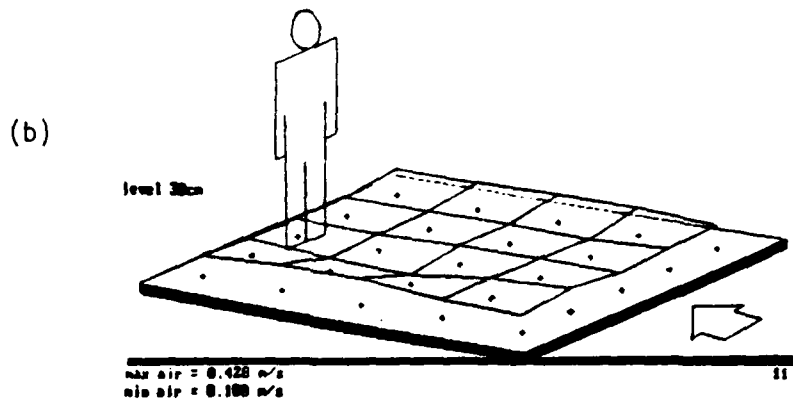
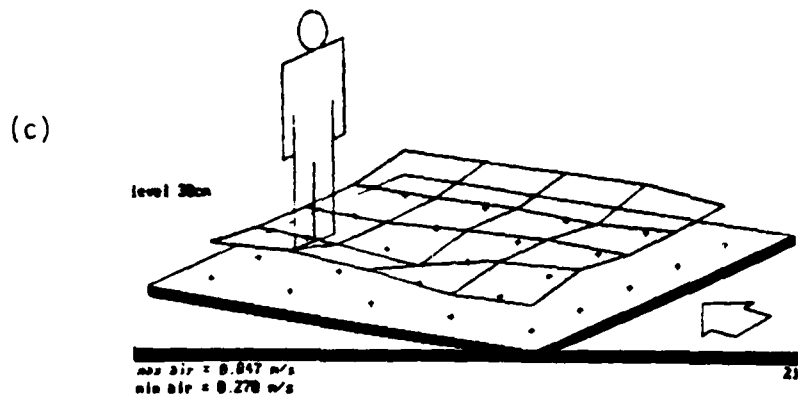
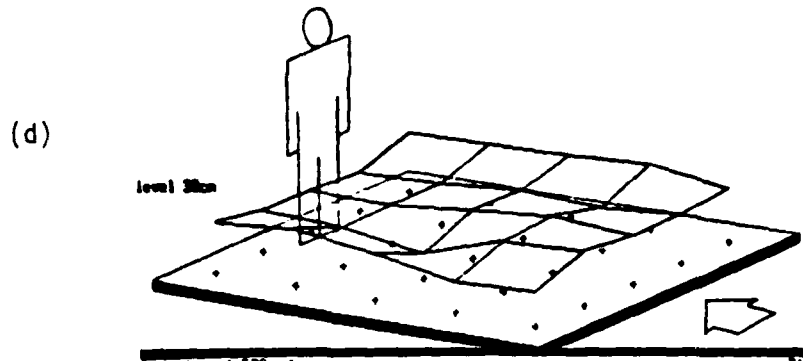

Figure 5 Air velocity map at 30cm height level, schematic of manikin included

max air = 2.832 m/s
min air = 0.906 m/s

42

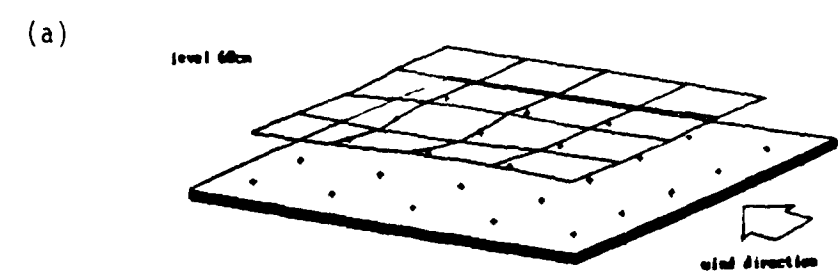
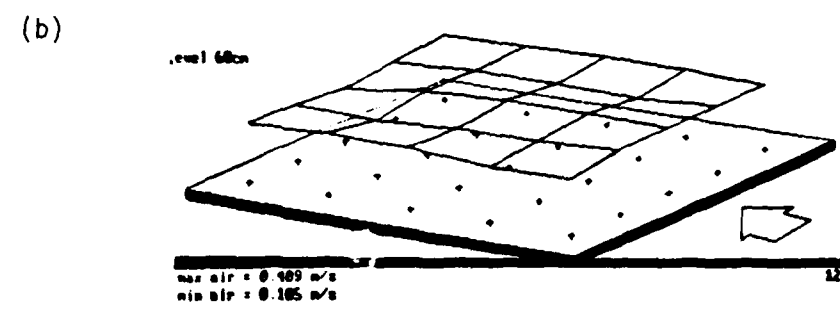
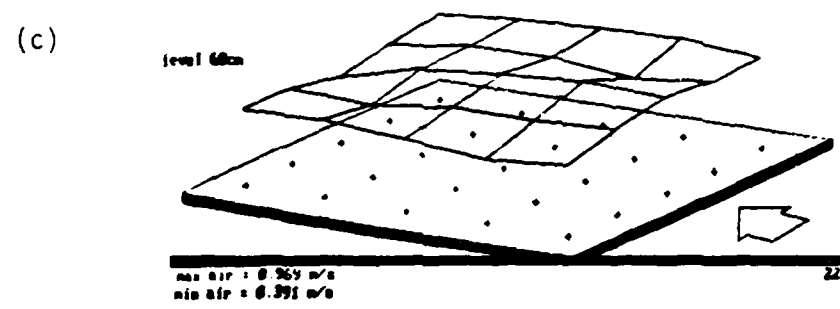
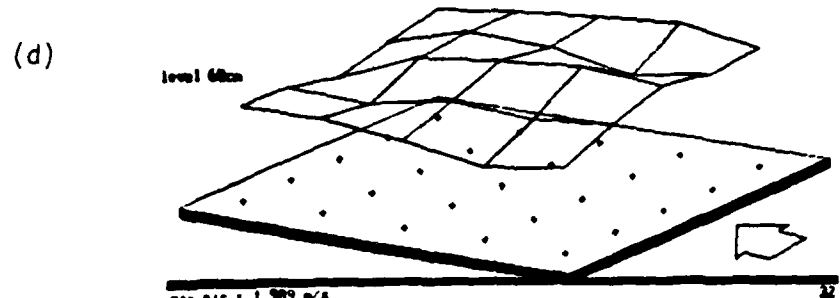

Figure 6 Air velocity map at 60cm height level, schematic of manikin removed

max air = 2.986 m/s
min air = 0.737 m/s

6

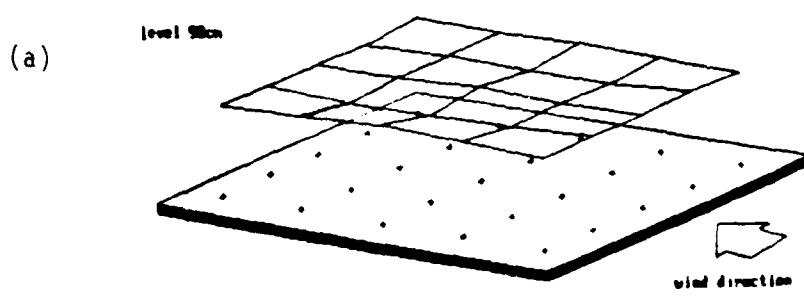
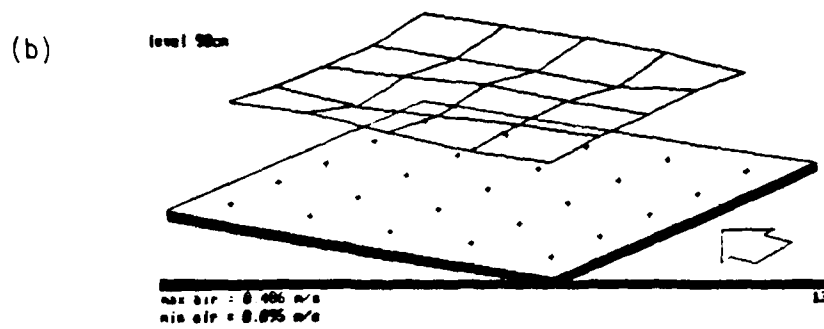
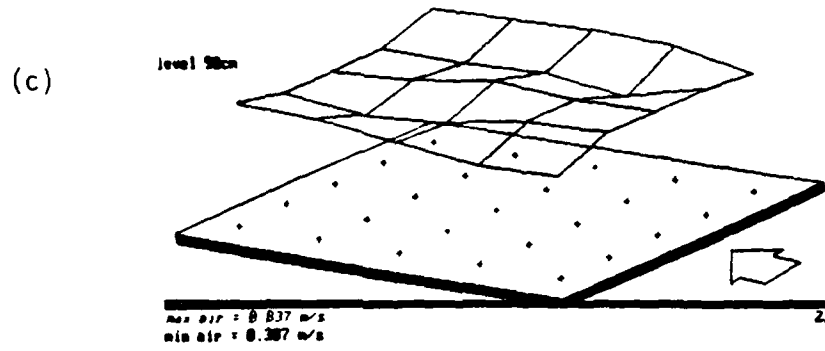
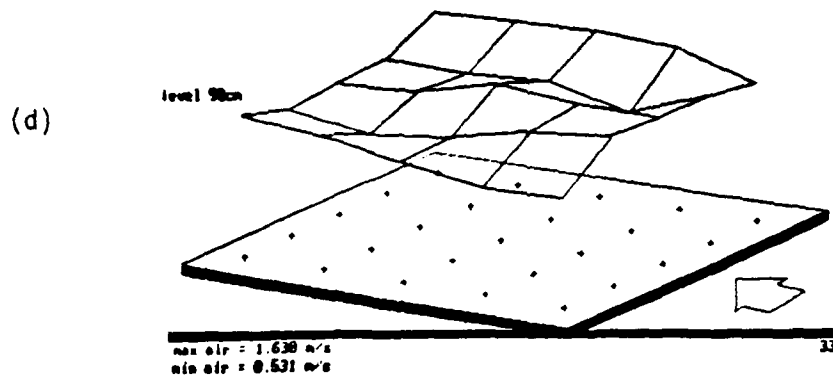

Figure 7 Air velocity map at 90cm height level, schematic of manikin removed

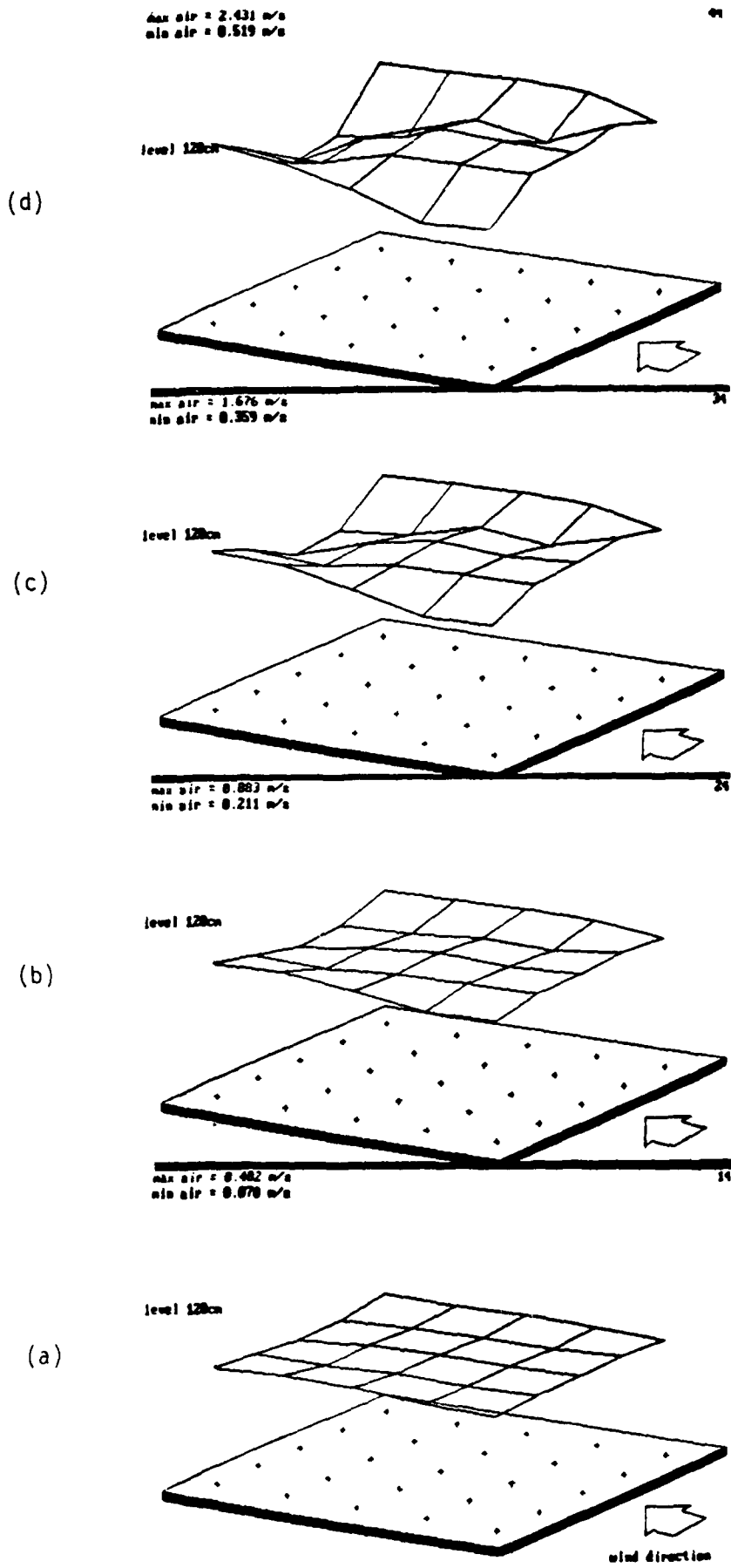

Figure 8 Air velocity map at 120cm height level, schematic of manikin removed

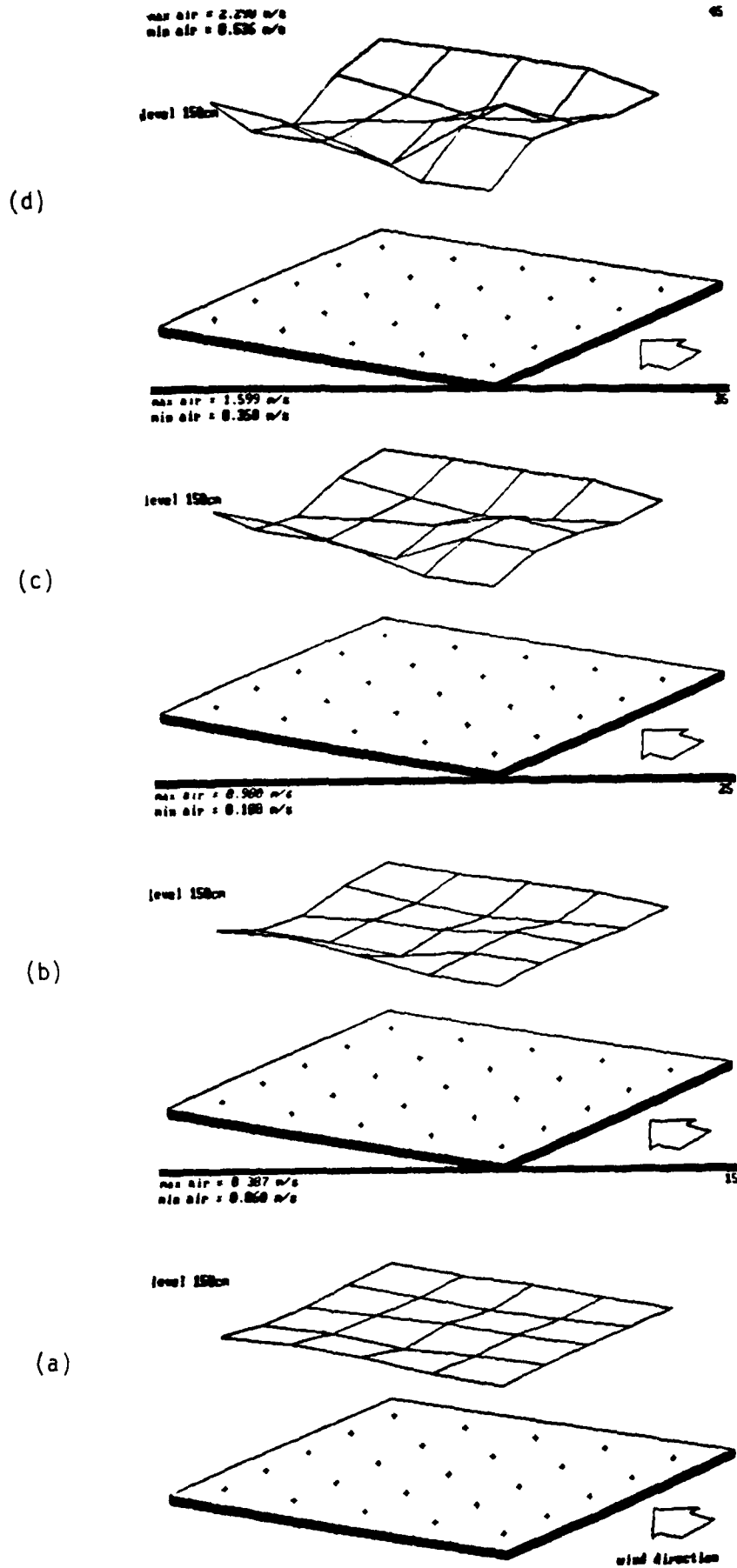

Figure 9 Air velocity map at 150cm height level, schematic of manikin removed

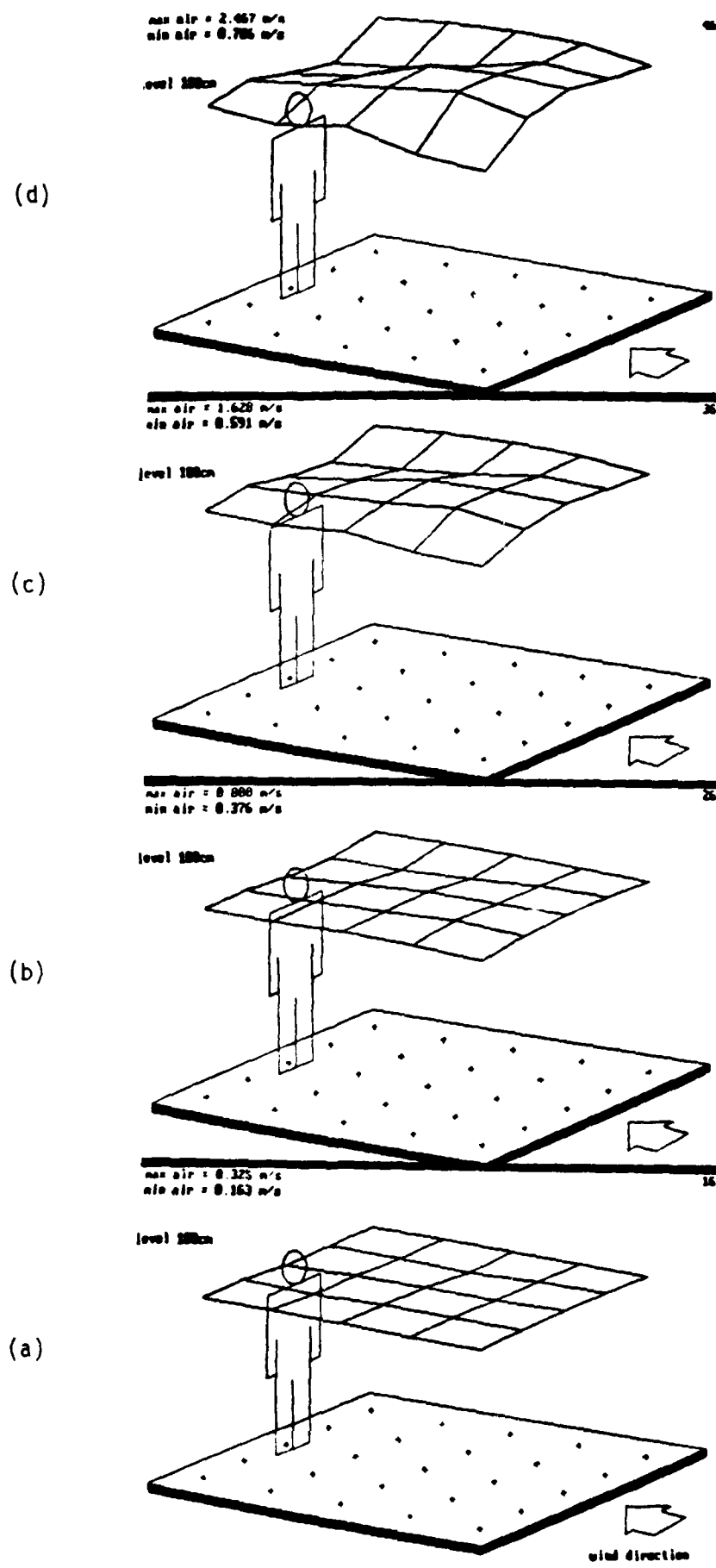

Figure 10 Air velocity map at 180cm height level, schematic of manikin included

```

      wind speed = 4; chamber dim. = 5 * 5 ; anemometer level = 6
      w                                x * y                                z
highest wind setting = 4                                6 = 180 cm
lowest wind setting = 1                                1 = 30 cm
FOR w = 4 TO 1 STEP -1 ' for 4 chamber wind speed settings
  FOR z = 6 TO 1 STEP -1
    wmax(w, z) = 0
    wmin(w, z) = 1000 ' initialize max & min air velocity
  NEXT z
  read in chamber air velocity data
  FOR x = 1 TO 5 ' cham(w, x, y, z)
    FOR y = 1 TO 5 ' chamber dim. = x * y
      FOR z = 6 TO 1 STEP -1 ' anemometer level = z
        READ cham(w, x, y, z) ' chamber wind speed = w
        IF cham(w, x, y, z) > wmax(w, z) THEN
          wmax(w, z) = cham(w, x, y, z)
        END IF
        IF cham(w, x, y, z) < wmin(w, z) THEN
          wmin(w, z) = cham(w, x, y, z)
        END IF
      NEXT z
    NEXT y
  NEXT x
NEXT w

ScrLevel: ' misc input & screen displays
LOCATE 25, 1: PRINT SPC(79);
LOCATE 25, 1
PRINT "Enter wind speed (1-4), chamber level (1-6), ";
INPUT "{11 to 46}, 0 to quit "; pp%

SELECT CASE pp%:
CASE 0 ' Quit
  SCREEN 0: CLS : END
CASE 11 TO 16
  w% = 1 ' w% = selected chamber wind speed
  z% = pp% - w% * 10 ' z% = selected chamber level
CASE 21 TO 26
  w% = 2
  z% = pp% - w% * 10
CASE 31 TO 36
  w% = 3
  z% = pp% - w% * 10
CASE 41 TO 46
  w% = 4
  z% = pp% - w% * 10
CASE ELSE
  BEEP
  LOCATE 24, 1: PRINT SPC(79);
  LOCATE 24, 1
  PRINT "acceptable input: 11-16, 21-26, 31-36, 41-46";
  GOTO ScrLevel
END SELECT

```

```

CLS ' start displaying air velocity map
PUT (0, 180), Bord ' display border outline
IF backgd = 1 THEN PUT (70, 70), Manp ' display mannikin
LOCATE 20 - (2 * z% + 3), 1: PRINT "level "; level$(z%)
LOCATE 1, 2
PRINT "max air = ";
PRINT USING "#.###"; wmax(w%, z%); : PRINT " m/s"
LOCATE 2, 2
PRINT "min air = ";
PRINT USING "#.###"; wmin(w%, z%); : PRINT " m/s"
LOCATE 1, 77: PRINT pp%; ' print input selection
PSET (px, py) ' Compute air velocity map
range = (wmax(w%, z%) - wmin(w%, z%))
FOR y = 1 TO 5
FOR x = 1 TO 5
tt = (cham(w%, 5 - x + 1, y, z%) / wmax(w%, z%)) * range * 37
tt = CINT(30 * (z% - 1) + tt)
vx(x, y) = POINT(0)
vy(x, y) = POINT(1) - tt
DRAW "TA=" + VARPTR$(ax) + "BR=" + VARPTR$(ix)
NEXT x
PSET (px, py): yy = sy * y
DRAW "TA=" + VARPTR$(ay) + "BU=" + VARPTR$(yy)
NEXT y
FOR y = 1 TO 5 ' Plot air velocity map (simulated 3D)
FOR x = 1 TO 5
IF x < 5 THEN
LINE (vx(x, y), vy(x, y))-(vx(x + 1, y), vy(x + 1, y))
END IF
IF y < 5 THEN
LINE (vx(x, y), vy(x, y))-(vx(x, y + 1), vy(x, y + 1))
END IF
NEXT x
NEXT y
LOCATE 25, 1
PRINT "<ENTER>=new wind/level,";
PRINT "<SPACE>=remove/add mannikin, <ESC>=quit";
NextSel1:
b$ = INKEY$
IF b$ = "" THEN
GOTO NextSel1
ELSEIF b$ = CHR$(27) THEN ' <ESC> to quit
SCREEN 0: CLS : END
ELSEIF b$ = CHR$(32) THEN ' <SPACE> to remove/add mannikin
PUT (70, 70), Manp
IF backgd = 1 THEN backgd = 0 ELSE backgd = 1 ' toggle
GOTO NextSel1 ' background display indicator
ELSEIF b$ = CHR$(13) THEN ' go to display
GOTO ScrLevel ' new wind speed/chamber level

```

```
ELSE BEEP  
GOTO NextSel1  
END IF
```

DISTRIBUTION LIST

2 Copies to:

Commander
U.S. Army Medical Research and Development Command
ATTN: SGRD-RMS
Fort Detrick
Frederick, MD 21701-5012

1 Copy to:

Commandant
U.S. Army Academy of Health Sciences
ATTN: AHS-COM
Fort Sam Houston, TX 78234

1 Copy to:

Director, Biological and Med Sciences Division
Office of Naval Research
800 N. Quincy Street
Arlington, VA 22217

1 Copy to:

Commanding Officer
Naval Medical Research and Development Command
National Naval Medical Center
Bethesda, MD 20014

1 Copy to:

Commander
HQS, AFMSC/SGPA
Brooks Air Force Base, TX 78235-5000

1 Copy to:

Director, Defense Research and Engineering
ATTN: Assistant Director (Environment and Life Sciences)
Washington D.C. 20301

1 Copy to:

Dean
School of Medicine
Uniformed Services University Of The Health Sciences
4301 Jones Bridge Road
Bethesda, MD 20814-4799

2 Copies to:

Commander
U.S. Army Medical Research Institute of Chemical Defense
Aberdeen Proving Ground, MD 21010-5425

2 Copies:

Commander
U.S. Army Chemical Research and Development Center
Aberdeen Proving Ground, MD 21010-5423

2 Copies:

Commandant
U.S. Army Chemical School
Fort McClellan, AL 36205-5020

2 Copies:

Commander
U.S. Army Medical Research and Development Command
ATTN: SGRD-PLE
Fort Detrick
Frederick, MD 20701-5012

2 Copies:

Commander
U.S. Air Force School of Aerospace Medicine
Brooks Air Force Base, TX 78235-5000

2 Copies:

Commander
Naval Health Research Center
P.O. Box 85122
San Diego, CA 92138-9174

2 Copies:

Commander
U.S. Army Biomedical Research and Development Laboratory
Fort Detrick
Frederick, MD 21701-5010

2 Copies:

Commander
U.S. Army Medical Materiel Development Activity
Fort Detrick
Frederick, MD 21701-5009

2 Copies:

U.S. Army Military Liaison Officer to DCIEM
1133 Sheppard Avenue W.
P.O. Box 2000
Downsview, Ontario
CANADA M3M 3B9

1 Copy:

Walter Reed Army Institute of Research
ATTN: SGRD-UWE-C
Washington D.C. 20307

1 Copy:

Commander
U.S. Army Environmental Hygiene Agency
Aberdeen Proving Ground, MD 21010-5422