

DTIC FILE COPY

2

# NAVAL POSTGRADUATE SCHOOL Monterey, California

AD-A199 979



## THESIS

STRATEGIC PLANNING IN THE  
U. S. COAST GUARD:  
A CASE STUDY OF THE OFFICE OF  
COMMAND, CONTROL AND COMMUNICATIONS

by

Francis X. Irr, Jr.

June 1988

Co-Advisor  
Co-Advisor

Roger D. Evered  
Benjamin J. Roberts

Approved for public release: distribution is unlimited.

DTIC  
ELECTE  
NOV 01 1988  
S E D

88 1031 136

Unclassified

security classification of this page

REPORT DOCUMENTATION PAGE				
1a Report Security Classification <b>Unclassified</b>		1b Restrictive Markings		
2a Security Classification Authority		3 Distribution Availability of Report		
2b Declassification Downgrading Schedule		Approved for public release; distribution is unlimited.		
4 Performing Organization Report Number(s)		5 Monitoring Organization Report Number(s)		
6a Name of Performing Organization Naval Postgraduate School	6b Office Symbol (if applicable) 62	7a Name of Monitoring Organization Naval Postgraduate School		
6c Address (city, state, and ZIP code) Monterey, CA 93943-5000		7b Address (city, state, and ZIP code) Monterey, CA 93943-5000		
8a Name of Funding Sponsoring Organization	8b Office Symbol (if applicable)	9 Procurement Instrument Identification Number		
8c Address (city, state, and ZIP code)		10 Source of Funding Numbers		
		Program Element No	Project No	Task No
		Work Unit Accession No		
11 Title (include security classification) <b>STRATEGIC PLANNING IN THE U. S. COAST GUARD: A CASE STUDY OF THE OFFICE OF COMMAND, CONTROL AND COMMUNICATIONS</b>				
12 Personal Author(s) <b>Francis X. Irr, Jr.</b>				
13a Type of Report Master's Thesis		13b Time Covered From To		15 Page Count 106
				14 Date of Report (year, month, day) June 1988
16 Supplementary Notation The views expressed in this thesis are those of the author and do not reflect the official policy or position of the Department of Defense or the U.S. Government.				
17 Cosati Codes			18 Subject Terms (continue on reverse if necessary and identify by block number)	
Field	Group	Subgroup	Strategic Management, Management Systems, Strategic Planning	
19 Abstract (continue on reverse if necessary and identify by block number)				
<p>The Coast Guard's planning system is in need of improvement. Questions remain, however, about how much and in what areas the changes need to be made to effect the improvements.</p> <p>The study uses the Coast Guard's Office of Command, Control and Communications (G-T) as an example for improving the overall Coast Guard planning system. It describes the current planning system and identifies its successes and problems. A method for formally analyzing the quality and effectiveness of the planning system is illustrated through the use of Tichy's model for strategic change management. Recommendations for changes to the strategic planning system are derived from the analysis of G-T.</p> <p>The study shows the strategic planning system in G-T is in need of improvement. The current system has some advantages, but its problems make the system less effective than it should be. Further, the Tichy model provides a comprehensive insight into planning problems and makes possible the identification of solutions to improve the planning system. It is recommended that managers in G-T become familiar with the Tichy model for future use in aligning the organization with its environment.</p>				
20 Distribution Availability of Abstract			21 Abstract Security Classification	
<input checked="" type="checkbox"/> unclassified unlimited <input type="checkbox"/> same as report <input type="checkbox"/> DTIC users			Unclassified	
22a Name of Responsible Individual Roger D. Evered		22b Telephone (include Area code) (408)646-2646		22c Office Symbol 54Ev

DD FORM 1473.84 MAR

83 APR edition may be used until exhausted  
All other editions are obsolete

security classification of this page

Unclassified

Approved for public release; distribution is unlimited.

Strategic Planning in the  
U. S. Coast Guard:  
A Case Study of the Office of  
Command, Control and Communications

by

Francis X. Irr, Jr.  
Lieutenant, United States Coast Guard  
B. S., U. S. Coast Guard Academy, 1981

Submitted in partial fulfillment of the  
requirements for the degree of

MASTER OF SCIENCE IN TELECOMMUNICATIONS SYSTEMS  
MANAGEMENT

from the

NAVAL POSTGRADUATE SCHOOL  
June 1988

Author:

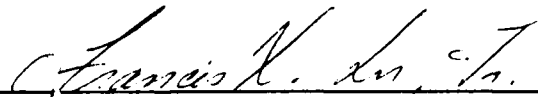

Francis X. Irr, Jr.

Approved by:

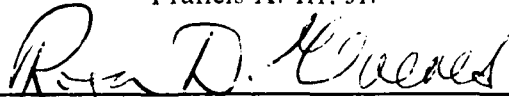

Roger D. Evered, Co-Advisor

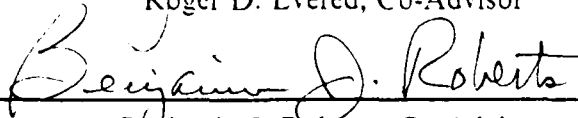

Benjamin J. Roberts, Co-Advisor

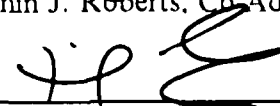

David R. Whipple, Chairman,  
Department of Administrative Sciences

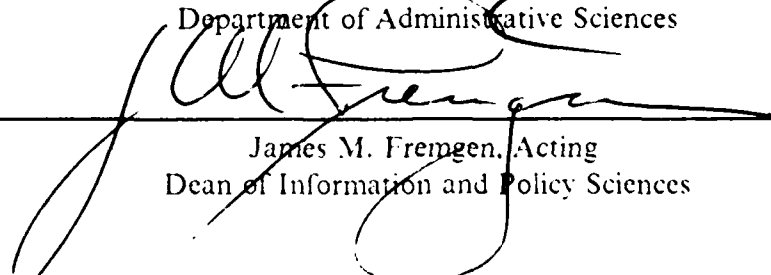

James M. Fremgen, Acting  
Dean of Information and Policy Sciences

## ABSTRACT

The Coast Guard's planning system is in need of improvement. Questions remain, however, about how much and in what areas the changes need to be made to effect the improvements.

The study uses the Coast Guard's Office of Command, Control and Communications (G-T) as an example for improving the overall Coast Guard planning system. It describes the current planning system and identifies its successes and problems. A method for formally analyzing the quality and effectiveness of the planning system is illustrated through the use of Tichy's model for strategic change management. Recommendations for changes to the strategic planning system are derived from the analysis of G-T.

The study shows the strategic planning system in G-T is in need of improvement. The current system has some advantages, but its problems make the system less effective than it should be. Further, the Tichy model provides a comprehensive insight into planning problems and makes possible the identification of solutions to improve the planning system. It is recommended that managers in G-T become familiar with the Tichy model for future use in aligning the organization with its environment.

TABLE OF CONTENTS

	Page
I. INTRODUCTION .....	1
A. RESEARCH QUESTION.....	2
B. METHODOLOGY OF THE STUDY.....	4
1. Purpose/Research Question.....	4
2. Literature Review and Data Collection.....	5
3. Facts And Problems.....	6
4. Analysis And Alternatives.....	7
5. Recommendations And Conclusions.....	7
C. THESIS ORGANIZATION.....	7
II. THE OFFICE OF COMMAND, CONTROL AND COMMUNICATIONS....	9
A. THE U. S. COAST GUARD.....	9
1. Missions.....	10
2. Organization.....	11
B. COAST GUARD HEADQUARTERS ORGANIZATION.....	13
C. HISTORY OF THE OFFICE OF C <sup>3</sup> (G-T).....	14
1. Concept Of The Office.....	14
2. Original Organization.....	15
D. SETTLING ON AN EFFECTIVE ORGANIZATONAL STRUCTURE.....	18
1. Problems With The Original Structure.....	18
2. The Present Organizational Structure.....	20
a. Office Staff.....	20
b. Plans And Policy Division (G-TPP).....	20

	c.	Informations Systems Division (G-TIS).....	22
	d.	Telecommunications Systems..... Division (G-TTS)	22
	e.	Electronic Systems Division (G-TES).....	22
	f.	Headquarters Command Center (G-TGC).....	23
	3.	G-T Councils.....	23
III.		THE G-T PLANNING SYSTEM.....	26
	A.	THE COMMANDANT'S LONG RANGE VIEW.....	26
	B.	THE OPERATING AND SUPPORT PROGRAM PLANS.....	27
	C.	THE LINK TO THE PROGRAMMING AND BUDGETING..... PROCESS	29
	D.	PROGRAM DESCRIPTIONS.....	31
IV.		SUCSESSES AND CURRENT PROBLEMS.....	33
	A.	SUCSESSES.....	33
		1. The Coast Guard Standard Terminal.....	33
		2. Interoperability With The Navy.....	36
		3. Career Development.....	37
	B.	CURRENT PROBLEMS.....	38
		1. Organizational Structure.....	39
		2. Communications.....	41
		3. Credibility.....	42
		4. Overtasking.....	43
		5. Planning And Guidance.....	44
	C.	SUMMARY.....	46

V.	ORGANIZATIONAL ANALYSIS MODEL.....	48
A.	HOW TO USE TICHY'S MODEL.....	49
	1. Guideline 1.....	51
	2. Guideline 2.....	51
B.	METHODOLOGY FOR ANALYZING ALIGNMENT WITHIN G-T...51	
C.	THE ENVIRONMENT.....	52
	1. Technical System.....	52
	2. Political System.....	53
	3. Cultural System.....	53
D.	ANALYSIS OF THE COMPONENTS OF THE MODEL.....	57
	1. Mission/Strategy.....	57
	2. Tasks.....	58
	3. Prescribed Networks.....	59
	4. People.....	61
	5. Process.....	62
	6. Emergent Networks.....	64
E.	ALIGNMENT OF THE THREE SYSTEMS.....	64
F.	SUMMARY OF RESULTS.....	65
VI.	RECOMMENDATIONS FOR IMPROVEMENT.....	69
A.	COUNCILS.....	69
B.	NEW PLANNING SYSTEM.....	71
C.	KEEP G-TPP WHERE IT IS.....	73
D.	INCREASE TOP MANAGEMENT'S VISIBILITY.....	74
E.	REWARDS.....	76
VII.	CONCLUSIONS.....	78
	LIST OF REFERENCES.....	81

APPENDIX: TICHY'S MODEL FOR STRATEGIC CHANGE.....83  
MANAGEMENT

A. COMPONENTS OF THE MODEL.....84

1. Inputs.....84
2. Mission/Strategy.....86
3. Tasks.....86
4. Prescribed Networks.....87
5. People.....87
6. Process.....87
7. Emergent Networks.....88
8. Output.....89

B. INTERRELATIONSHIPS BETWEEN MODEL COMPONENTS.....89

1. Technical Alignment.....91
2. Political Alignment.....91
3. Cultural Alignment.....92
4. Testing Consistency Between The Three.....93  
Systems

INITIAL DISTRIBUTION LIST.....95

<b>Accession For</b>	
NTIS GRA&I	<input checked="" type="checkbox"/>
DTIC TAB	<input type="checkbox"/>
Unannounced	<input type="checkbox"/>
Justification	
By _____	
Distribution/	
Availability Codes	
Dist	Avail and/or Special
A-1	





LIST OF TABLES

Table 4.1	G-T Problem Summary.....	47
Table 5.1	Summary Format for Analysis of Alignments	50
Table 5.2	Summary of Analysis of Alignments..... for G-T	66

LIST OF FIGURES

Figure 2.1 Coast Guard Geographical Distribution....12

Figure 2.2 Coast Guard Organization Chart.....13

Figure 2.3 Coast Guard Headquarters Organization....14  
Chart

Figure 2.4 Coast Guard Headquarters Pre-T.....16  
Organization

Figure 2.5 G-T Pre-1986.....17

Figure 2.6 G-T Post-1986 Reorganization.....21

Figure 2.7 The G-T Councils.....24

Figure 3.1 Coast Guard Headquarters Planning.....27  
Process

Figure 3.2 The Planning, Programing and Budgeting...29  
System

Figure 6.1 The Proposed Planning Process.....72

Figure A.1 Tichy's Organizational Model.....85

Figure A.2 Tichy's Managerial Tools.....90

## I. INTRODUCTION

In 1990 the United States Coast Guard celebrates its two hundredth birthday. Over of the past two hundred years the service has grown in size and responsibility while being given less resources to perform its additional missions. How does the service survive in the today's turbulent environment under these conditions?

Sound strategic planning is one of the areas of management that can ensure the long term survival of an organization [Ref. 1]. If an organization is doing the right things its products will be in demand and the organization will be supported. What is the state of the Coast Guard's strategic planning system?

This thesis studies the Office of Command, Control and Communications (G-T) to gain an insight into how the Coast Guard actually does its planning. Like the rest of the Coast Guard, G-T has had many successes and failures since its creation in 1981. Its effectiveness throughout the period has been questioned by many, including the top G-T managers. As a result, the Office has re-evaluated its own capabilities and reorganized itself four times in the last seven years. It is still reorganizing today.

This research project has helped reinforce the author's learning experience at the Naval Postgraduate School. It

is hoped that some of the analyses and recommendations contained in this thesis may provide G-T and the Coast Guard with a new way of evaluating its strategic planning systems to ensure a successful strategic posture in today's environment.

#### A. RESEARCH QUESTION

The research question this study will attempt to answer is as follows:

**Is it possible to improve Coast Guard planning and, if so, how?**

A study of the entire Coast Guard planning system would require more time and resources than are available. However, a unit responsible for planning and management of a Coast Guard program can provide insight into how the service as a whole plans.

The Coast Guard Office of Command, Control and Communications (G-T) was chosen as a representative unit of the Coast Guard to serve as a sample of Coast Guard planning for the study. It is located in Coast Guard Headquarters and performs all planning functions for the Command, Control and Communications (C<sup>3</sup>) program in the service. Further, G-T requires a well developed planning system due to its turbulent environment.

To break down the main research question into manageable parts, four sub-questions have been formulated:

- 1) How does G-T currently do its planning?
- 2) What are the successes and current problems of G-T's existing planning system?
- 3) What processes or procedures might be used to formally assess the quality of an organization's planning system?
- 4) What kind of changes in management/organization might be recommended to improve the existing planning system in G-T?

These four questions provide the framework for the study.

First, the G-T planning system will be described. Coast Guard Headquarters (CGHQ) has a planning system that is used by each office that manages a Coast Guard program. G-T serves as a good representation of how planning is done in other offices at CGHQ.

Secondly, the successes resulting from the good planning efforts in G-T, as well as the problems will be presented. These successes and problems were identified through informal interviews conducted with G-T personnel and studies conducted in G-T during the past four years.

Thirdly, Noel Tichy's model for strategic change management will be demonstrated as a formal way to assess or evaluate an organization's planning system. This model is used to analyze the organization and management processes that ensure G-T's strategic alignment with its environment. The assumption is, if the organization can reorient itself to technical, political or cultural change, the planning system is sound. [Ref. 2]

Finally, the study will make recommendations, based on the analysis, for G-T to improve its planning system. It is assumed that most of the recommendations will be applicable to the rest of the Coast Guard, as well.

#### **B. METHODOLOGY OF THE STUDY**

The study follows the scientific method of problem solving:

- 1) State the purpose of the study.
- 2) Review the literature and collect data about the organization relating to the purpose.
- 3) Present the facts of the case and identify the problems.
- 4) Analyze the facts and present alternatives to the problems.
- 5) Offer recommendations for change.

A summary of the methodology used in each part of the study is presented in this section.

##### **1. Purpose/Research Question**

The study questions were based on the author's interests, future career path and perceived Coast Guard needs. Strategic planning is an important topic in today's ever-changing world and this study has given the author an opportunity to explore this topic. Further, the author's future career path in communications management made it practical to explore the Coast Guard's C<sup>3</sup> management techniques.

## 2. Literature Review and Data Collection

The literature review was conducted onboard the Naval Postgraduate School in Monterey, CA. Most of the initial review was directed towards the subject of strategic planning.

Collection of data consisted of interviews of personnel in the Coast Guard Office of Command, Control and Communications (G-T) and collection of various documents and studies during the interview period in Washington D.C.

The interviews were conducted in March 1988 during a trip by the author to G-T. The interviews were concentrated in the Strategic Planning Branch of the Plans and Policy Division of the office. However, interviews were also conducted in other divisions of the office and at all levels of the G-T organization. Unfortunately, access to the top managers of the organization was limited due to time constraints.

During the interview process two studies commissioned by G-T top managers were discovered. These studies were:

- 1) The Culbertson Study--This study was commissioned by the Chief of the Office of Command, Control and Communications in 1984. The study chairman, Coast Guard Captain James F. Culbertson, was tasked with examining the role and effectiveness of the office and identifying successes and major problems areas within the organization, both at Headquarters and in the field. He was to highlight the specific issues underlying the problems identified and propose solutions leading to their elimination; [Ref. 3: Encl 1] and

- 2) The Critical Success Factor Study--Commissioned in 1987 by the Chief of the Office of Command, Control and Communications, this study was conducted by the U.S. Department of Transportation, Transportation Systems Center and Index Group, Inc., a commercial consulting group. The study was implemented to clarify the steps required to produce a system for management of on-going and future activities. The study involved participation of all management levels in the office. [Ref. 4]

Because the study groups had more time and access to more people in the organization, their collection of data was more complete. Data quoted from the studies have been used to fill the information gaps missed in the author's interviews.

### 3. Facts And Problems

The facts extracted from the data collected above are presented as a case study. The case is intended to answer sub-questions one and two and is presented in two parts:

- 1) The organizational structure and planning processes; and
- 2) The organization's successes and current problems.

The case study provides the background information about the Coast Guard and G-T collected during the interviews, from G-T studies and from office documents. This background prepares the reader to follow the evaluation of G-T's planning system.



#### **4. Analysis And Alternatives**

Noel Tichy's Model for Strategic Change Management was chosen to be used in illustrating how G-T can formally assess its planning system. The model is taken from Tichy's book, **Managing Strategic Change**. The analysis of G-T is performed using the concepts and procedures developed in this book. Alternative solutions to problems are given throughout the analysis.

#### **5. Recommendations And Conclusions**

The recommendations for improvement of the organization's processes and planning practices are based on Tichy's model. The recommendations given are the implementable solutions to problems. Conclusions about the Coast Guard and G-T planning systems are drawn from the study.

#### **C. THESIS ORGANIZATION**

The thesis is organized consistent with the parts of the study discussed above. A brief overview of the thesis organization follows.

Chapters II, III and IV constitute the case study of the G-T organization. Chapter II describes the Coast Guard's mission and organization, G-T's mission and formal and informal structure. Chapter III describes G-T's planning system. Chapter IV discusses the successes of the organization, since its creation in 1981, as well as the

problems with the planning system identified during the research phase.

Chapter V gives a brief explanation of how Noel Tichy's Model for Strategic Change Management is used in the study to assess the quality of G-T's planning system. The evaluation technique is demonstrated using the information gathered about G-T during the research phase of the study. A discussion of how it will be used in the analysis of the G-T organization follows the explanation.

Chapter VI gives recommendations for organizational change to help G-T reorient itself to its environment. The recommended adjustments will presumably improve the organization's planning system, putting G-T in closer touch with its environment. The recommendations are based on the analysis in Chapter IV.

Finally, Chapter VII makes conclusions about the study and the possible implications of techniques derived herein.

## **II. THE OFFICE OF COMMAND, CONTROL AND COMMUNICATIONS**

This chapter presents the purpose and structure in which the Office of Command, Control and Communications (G-T) operates. It discusses the creation and structural evolution of the office, as well as some of its processes. The information in this chapter will provide the background necessary to follow the analysis of the organization later in the thesis.

G-T is a functional unit of the Coast Guard Headquarters Staff. It is a Support Program which controls resources at every level of the Coast Guard organization. In order to appreciate the functions and responsibilities of G-T, the environmental context in which the organization operates must be understood.

### **A. THE U.S. COAST GUARD**

The U.S. Coast Guard was created in 1790 by President George Washington to enforce customs laws in the navigable waters of the United States. Since that time, the service has undergone tremendous growth, taking on additional law enforcement, maritime safety and defense missions.

The organization is made up of 40,000 people with an annual budget of approximately two billion dollars. Given the Coast Guard's missions and the service it provides to

the public, the Coast Guard is one of the best values to the American taxpayer. Dollar-for-dollar the Coast Guard returns as much benefit to the public as any other federal agency and far more than is appropriated to the service.

To maintain this high level of performance in a budget cutting environment the Coast Guard reorganized support functions in 1986. The intent was to eliminate overhead, concentrating on operation and the deliverables to the public. A discussion of the Coast Guard's missions and present organization follows.

1. Missions

The Coast Guard's missions can be divided into three functional areas: maritime law enforcement, maritime safety and national defense.

Maritime law enforcement is the Coast Guard's oldest and most important mission. It was established as a mission in 1790 with the creation of the Revenue Cutter Service, the Coast Guard's predecessor. The original statutory mandate, enforcement of customs laws, is still the Coast Guard's major authority for law enforcement operations. Law enforcement responsibilities range from drug interdiction to immigration laws to treasury laws. The Coast Guard is the federal law enforcement arm on the high seas and in U.S. territorial waters.

Maritime safety is the most publicized mission of the Coast Guard. Search and Rescue is the service's most

successful and rewarding mission. Other areas of maritime safety, however, are just as important. Aids to navigation, marine vessel inspection, port safety and pollution response are all statutory assignments to the Coast Guard.

National defense is the third mission area the Coast Guard is involved in. The Coast Guard works closely with the Navy in times of war and is assigned coastal defense responsibilities. Coast Guard ships regularly participate in Navy exercises and training programs. The Coast Guard is an Armed Force of the U.S. and participates in the defense of the country.

As a support function, G-T is tasked with developing Command, Control and Communications (C<sup>3</sup>) systems for the diverse missions of the service. It is apparent that the Coast Guard is a multi-missioned service, working with a variety of federal, state and local agencies. Developing C<sup>3</sup> systems that are interoperable with these agencies is a formidable task.

## 2. Organization

The Coast Guard is organized hierarchically by geographic location. As shown in Figure 2.1 the Coast Guard is divided into two Area Commands: Pacific and Atlantic. Area Commanders, located on Governor's Island, NY and at Alameda, CA, are in charge of carrying out the missions specified above within their areas. To aid the Area

Commanders in managing their large Areas, Districts were formed. [Ref. 5]

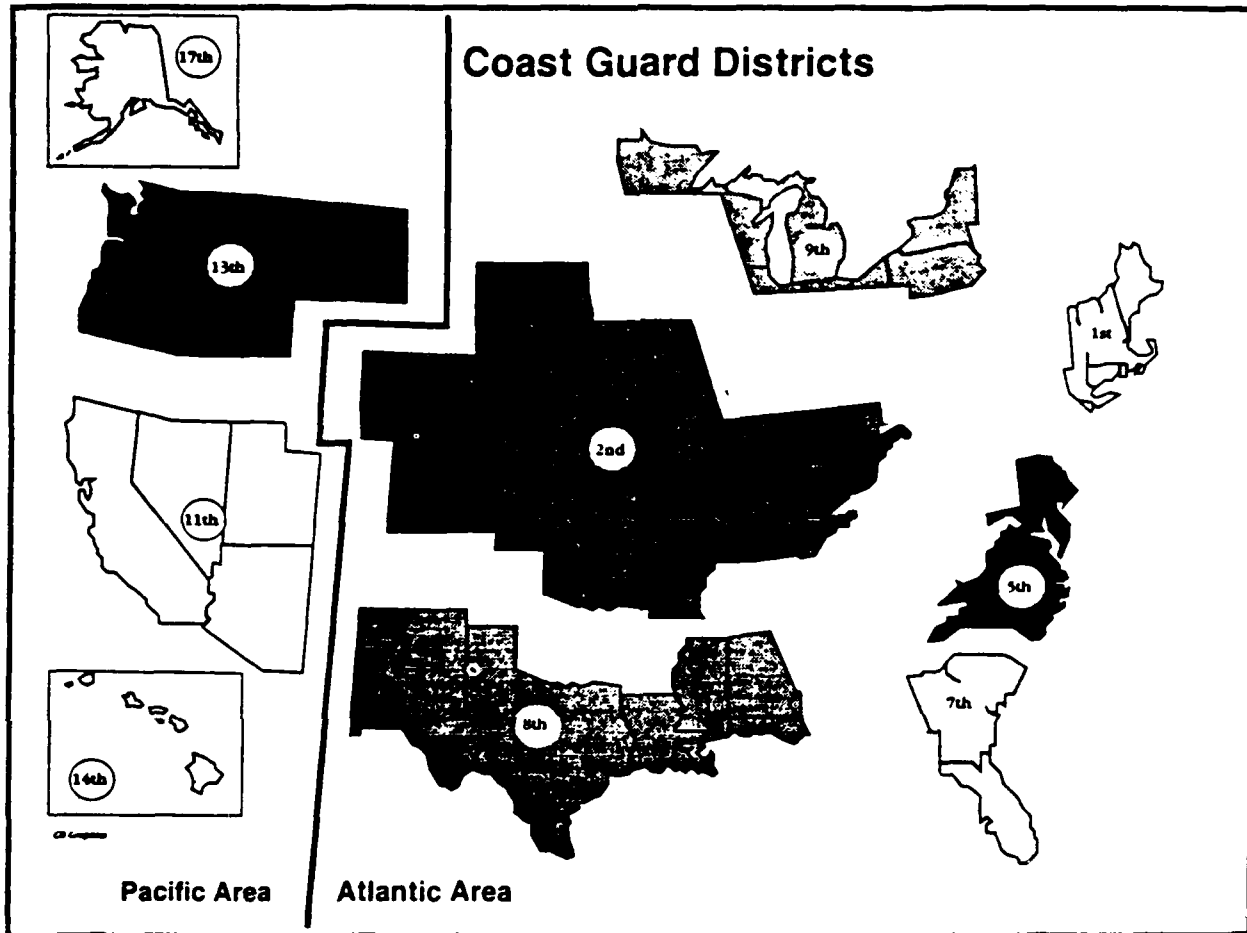

Figure 2.1: Coast Guard Geographical Distribution

The Atlantic Area has six Districts and the Pacific has four. The District Office, headed by a two-star admiral is the hub of operations within its geographic area. The Area Commanders have jurisdiction over operations that cross these District boundaries. As seen in Figure 2.2, there is a

Maintenance and Logistics Command located in each Area to provide support to all the Districts and operational forces.

[Ref. 6]

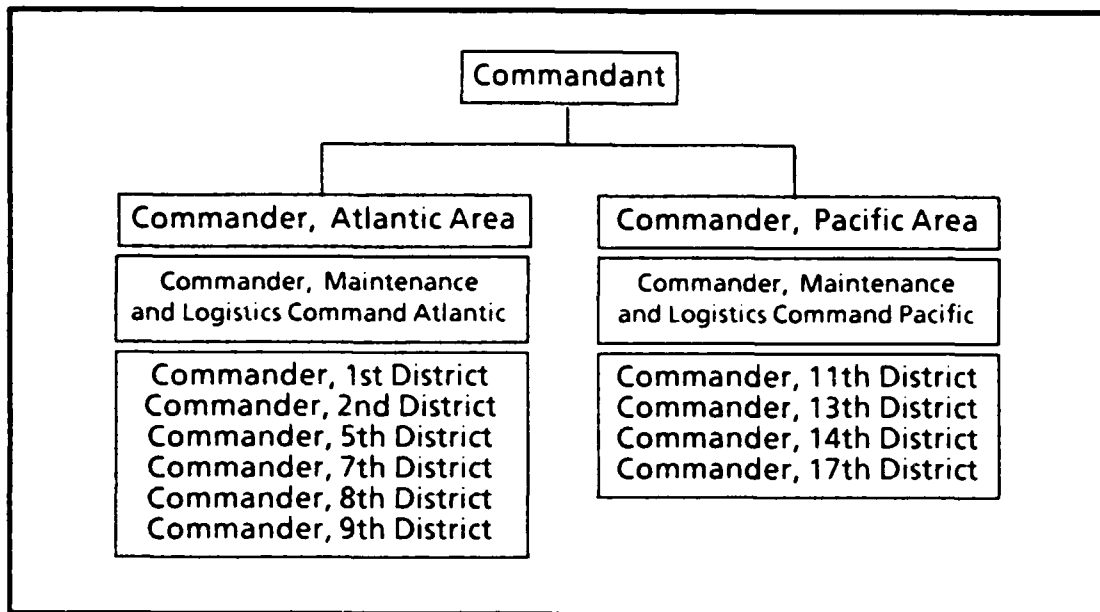

Figure 2.2: Coast Guard Organization Chart

G-T's interests are concentrated in the Area and District Command Centers which provide the Commanders C<sup>3</sup> support of their forces in the field. It is at these C<sup>3</sup> centers that the products of G-T meet the customers, the operational or field units.

#### B. COAST GUARD HEADQUARTERS ORGANIZATION

Figure 2.3 shows the command structure of Coast Guard Headquarters (CGHQ). The offices of Operations, Marine

Safety and Navigation manage Operating Programs because they provide direct service to the public. The other

offices manage Support Programs. Support Programs, such as the ones G-T manages, provide services to the Operating Program offices so that they can carry out their missions and responsibilities.

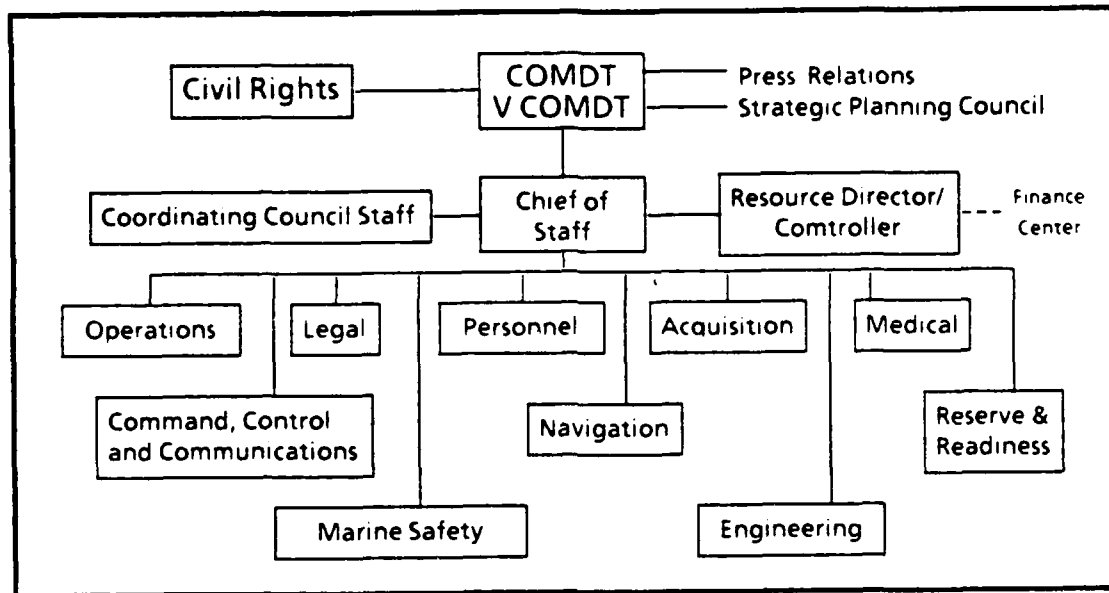

Figure 2.3: Coast Guard Headquarters Organization Chart

### C. HISTORY OF THE OFFICE OF C<sup>3</sup> (G-T)

This section discusses the creation and early evolution of the Office of Command, Control and Communications (G-T). Most of the historical data in this section was obtained from a Reorganization Request G-T submitted to the CGHQ Chief of Staff in January of 1986. [Ref. 7]

#### 1. Concept of the Office

G-T was established in May of 1981. The office was established to focus attention on Coast Guard Information



Resources Management (IRM) and Command, Control and Communications (C<sup>3</sup>) as special areas of management emphasis. The Coast Guard made the investment in organization, personnel and money through the establishment of the T organization. By focusing on C<sup>3</sup>/IRM, Coast Guard leaders expected to gain significant improvements in overall mission effectiveness and efficiency.

At the headquarters level, the G-T organizational structure reflected an integrated approach to information resource management (IRM) primarily by mixing the previously independent specialties and responsibilities of electronics engineering, telecommunications, and automated data processing (ADP). The move was consistent with current IRM and C<sup>3</sup> approaches in both industry and government, including DOD. It was intended to move the Coast Guard more aggressively into the information technology field. The thrust of G-T's mission was to identify and provide telecommunications and ADP resources required to support the Coast Guard's operational and support functions.

## 2. Original Organization

The Office of Command, Control and Communications was established in two phases. Initially, the staffs from the:

- 1) Electronics Engineering (G-EEE);
- 2) Telecommunications Management (G-OTM); and
- 3) Information Systems (G-FIS) Divisions

were transferred essentially intact from their traditional offices as shown in Figure 2.4. Also transferred to G-T were the Coast Guard Command Center staffs from:

- 1) Flag Plot (G-OFP or the Coast Guard Operations Center); and the
- 2) National Response Center (G-WER-1).

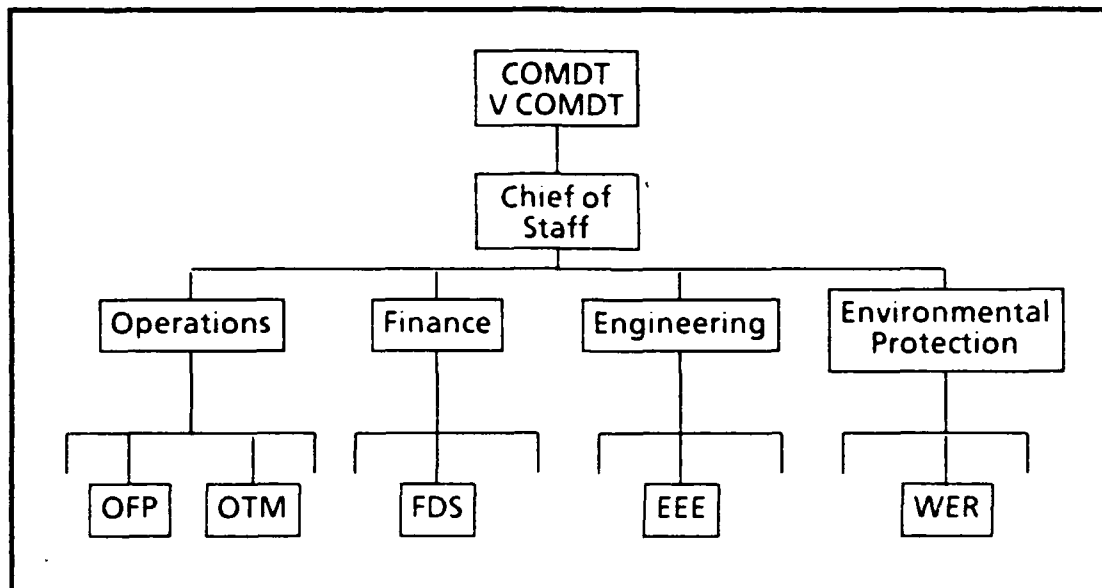

**Figure 2.4: Coast Guard Headquarters Pre-T Organization**

A year later, after studying the best way to coordinate these individual groups, the second phase of the reorganization occurred. Figure 2.5 shows the newly synthesized G-T organizational structure.

First, two Systems Divisions were created:

- 1) Data Systems Division (G-TDS); and
- 2) Electronic Systems Division (G-TES).

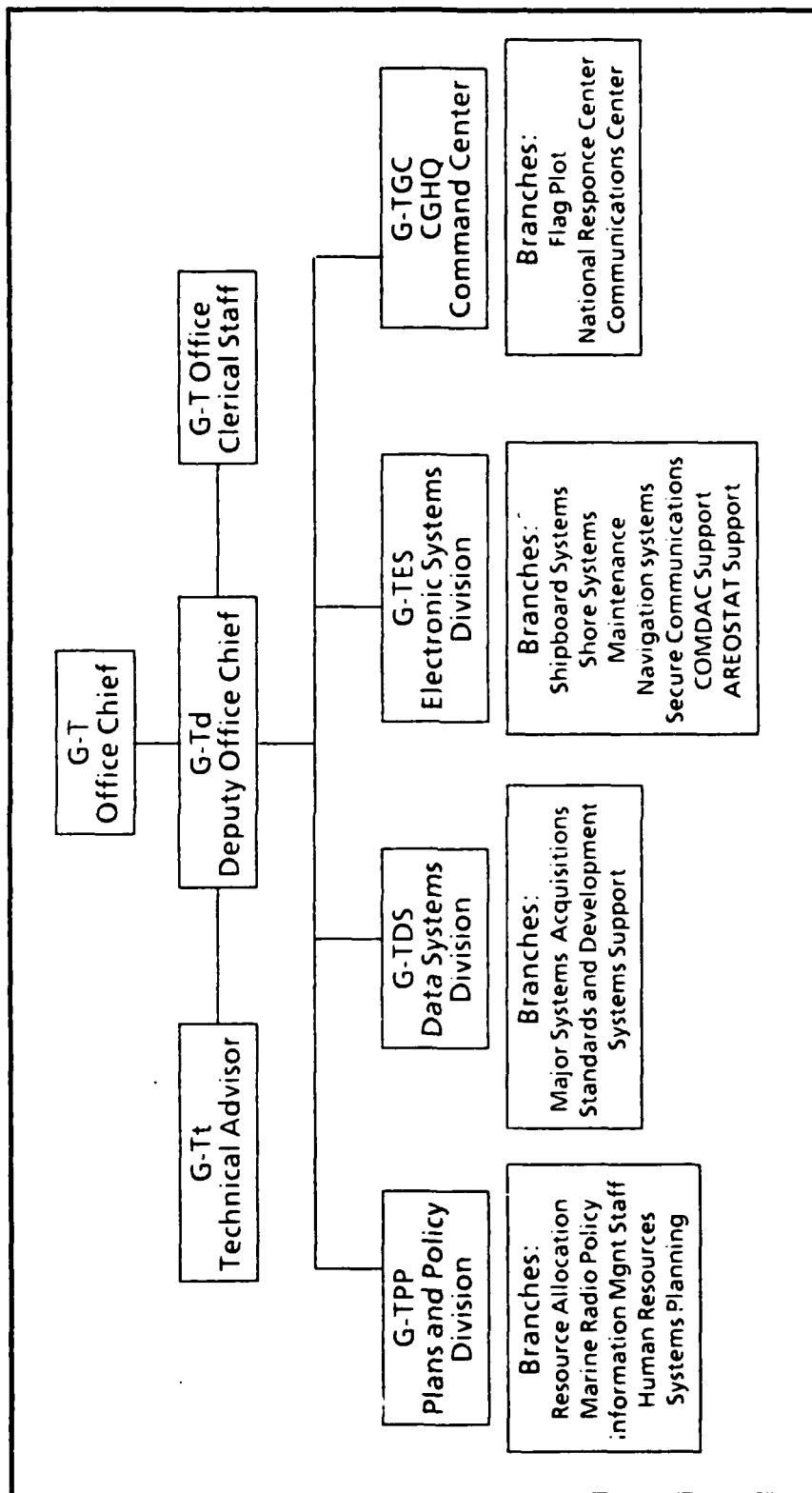

Figure 2.5: G-T Pre-1986

Then, a Plans and Policy Division (G-TPP) was created. Finally, Flag Plot, the National Response Center and the Telecommunications Center were combined into the Coast Guard Headquarters Command Center (G-TGC).

The telecommunications functions were split up between G-TES, G-TPP, and G-TGC. Area Office were expected to pick-up management of the "operational telecommunications".

#### **D. SETTLING ON AN EFFECTIVE ORGANIZATIONAL STRUCTURE**

This section explains the development of G-T's present organizational structure. Again, the information reconstructing the facts of the reorganization effort were extracted from the Reorganization Request. [Ref. 7]

##### **1. Problems With The Original Structure**

In 1986 G-T again evaluated its organizational structure and effectiveness. It was found that the structure which the office operated under for its first five years was far superior to the traditional orientation of spreading the electronics, telecommunications, and ADP functions over three offices. The new structure integrated the Coast Guard's approach to management of information resources and evaluation of emerging technologies. For example, the success of the standard terminal can be attributed to the synergy created in this organization. The Coast Guard Standard Terminal, which will be discussed in

detail later, was considered a major leap forward into the world of office automation and computer literacy for the Coast Guard. Internal studies, however, identified several problems that were hampering an otherwise good concept of managing T programs.

First, there was no longer a focus on telecommunications due to the dismantling and distribution of these functions (previously held by G-OTM). The Coast Guard was faced with new problems like Federal Telephone Service (FTS) cost containment, network interaction and the AT&T divestiture. A coordinated telecommunications focus was needed at this point to grapple effectively with these problems.

Secondly, the Plans and Policy Division (G-TPP) was seen as having too large a span of control. Because the original people that staffed G-TPP were so powerful, they were able to gain control of a lot of strategic functions in G-T. As a result G-TPP had accumulated important divisional duties and office staff functions.

G-TPP's divisional duties pertained mainly to allocations of the current year's budget and managing T resources. It's staff duties were human resource planning and executing G-T's Planning, Programming and Budgeting System (PPBS) responsibilities. These functions were too much for one division to manage effectively. Consequently,

G-TPP typically short changed the long-range strategic plans in order to accomplish near term plans.

Thirdly, other T divisions lacked the resources for product-line planning. Although G-TPP was tasked with this activity, it was felt that the other divisions should have this capability in-house because it dealt directly with their products.

## **2. The Present Organizational Structure**

The solution to these problems was to:

- 1) create a Telecommunications Systems Division to handle telecommunications problems; and
- 2) reallocate office functions and responsibilities to gain a more equitable distribution of power.

The reorganization of G-T divisional responsibilities in 1986 resulted in the present G-T structure (shown in Figure 2.6). The following is a breakdown of G-T's organization:

### **a. Office Staff**

Consists of the office chief, his deputy, technical advisor and clerical staff. The staff was deliberately kept small to reduce the administrative tasks for top level managers. Divisions have been delegated sufficient authority and responsibility to execute their programs within the constraints of broad policy guidance.

### **b. Plans And Policy Division (G-TPP)**

Responsible for managing all G-T resources including money and personnel. It coordinates all

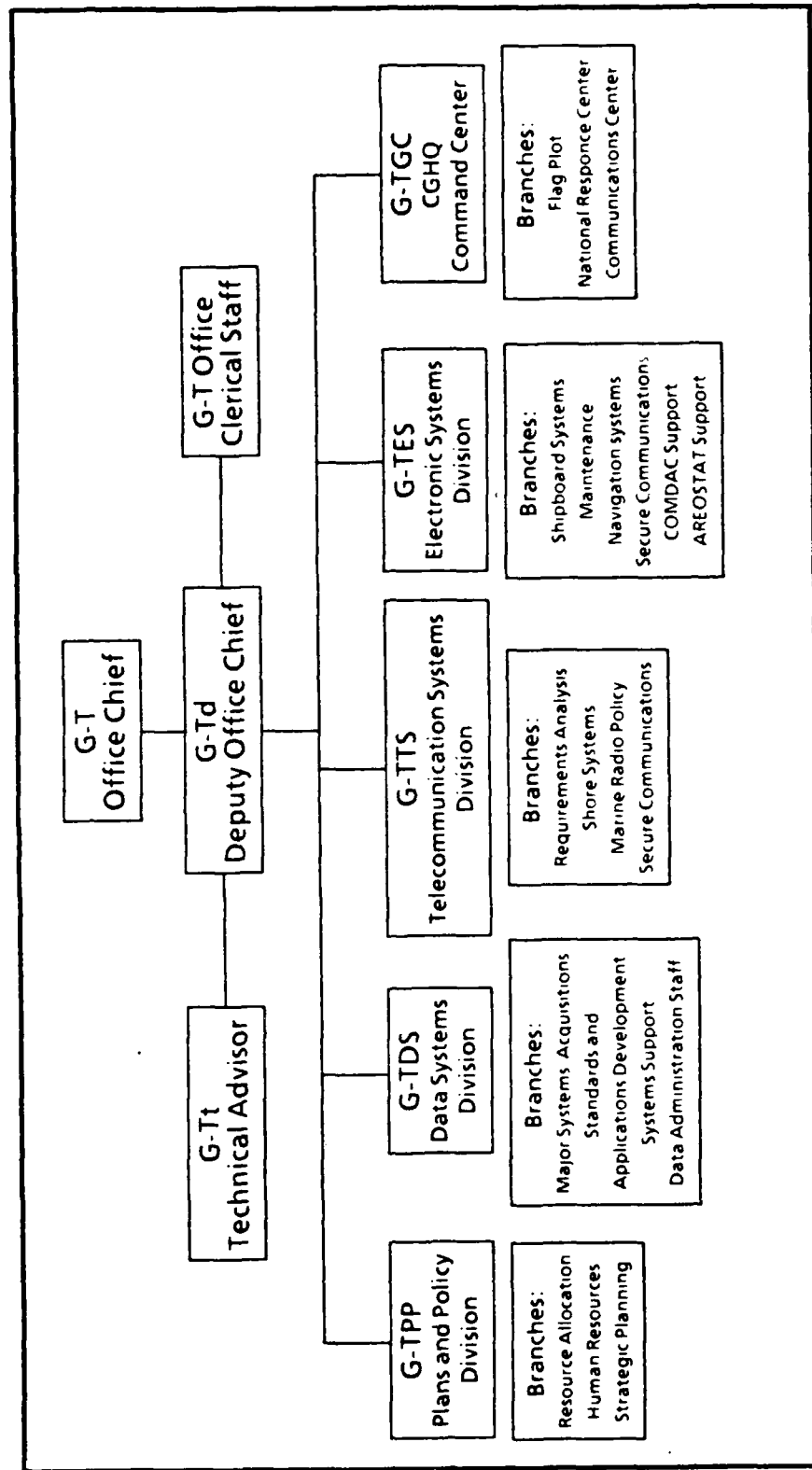

Figure 2.6: G-T Post-1986 Reorganization

planning, programming and budgeting (PPBS) activities and is responsible for strategic planning in the office.

**c. Information Systems Division (G-TIS)**

Responsible for all major field computer systems and associated software. This includes the development of service-wide standards for operation and security of ADP systems, as well as support for the Coast Guard Standard Terminal. It oversees the daily operations of the Transportation Computer Center (a DOT resource).

**d. Telecommunications Systems Division (G-TTS)**

Responsible for managing the Coast Guard Telecommunications System (CGTS). This includes landlines, radio communications, radio frequency management, AUTODIN, secure communications, etc. It also manages the Coast Guard's TEMPEST program (secure communications equipment) and coordinates the distribution of classified key materials in the Coast Guard.

**e. Electronics Systems Division (G-TES)**

Responsible for the management, acquisition and support of all Coast Guard electronics equipment. It works closely to the Electronics Engineering Center and Lab, Command and Control (COMDAC) Support Facility, districts, and all program managers on electronic issues. This division manages all electronics related project resources.



**f. Headquarters Command Center (G-TGC)**

Responsible for the operational and support functions of Flag Plot, the National Response Center and the Telecommunications Center. This Command Center is manned 24-hours per day and is not considered part of the daily management of the T program.

**3. G-T Councils**

Thus far the G-T organization has been described as being only functional in construction. However, three councils have been recently established to help integrate issues that cross divisional lines. The councils have been formed at the top, middle and bottom levels of the organization as shown in Figure 2.7. They were established to foster better communications between divisions, address interdivisional planning issues and define project management requirements which transcend divisions.

The councils are defined as follows:

- 1) Board of Directors (BOD)--Consists of office staff and all division chiefs. Responsible for the overall strategic decision making in G-T.
- 2) Deputy Division Chiefs Council (DDCC)--Consists of all assistant division chiefs in G-T. Responsible for improving communications between divisions and addressing issues whose scope crosses division boundaries.
- 3) Planning Council--Consists of a planning officer from each division. Chaired by a member of the DDCC, it is tasked by and reports to the DDCC. It is responsible for formulation and review of all G-T planning documents, coordination of projects crossing division lines and proposing annual goals and objectives for review by G-T.

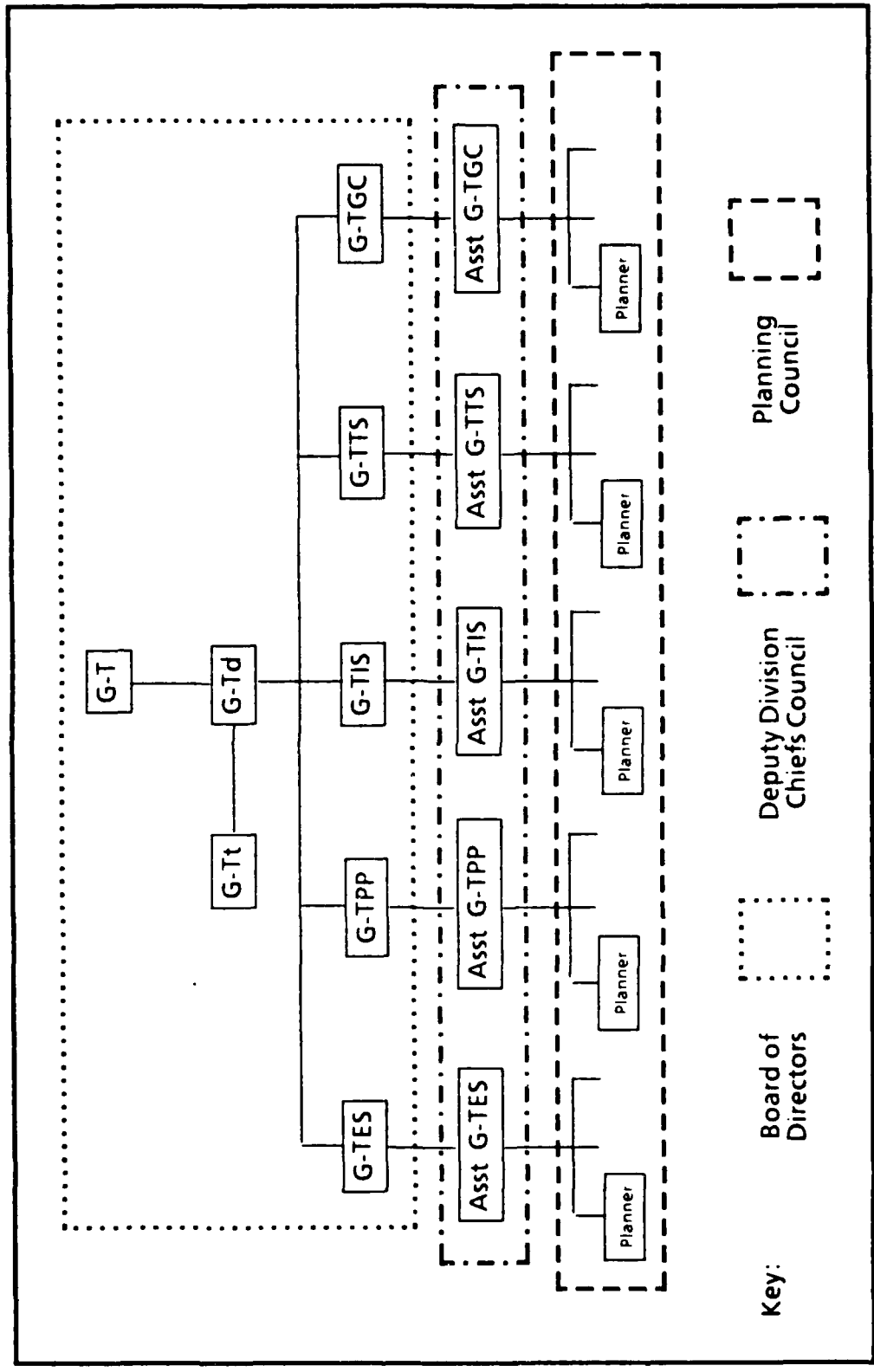

Figure 2.7: The G-T Councils

These councils have been in effect only a short time; therefore, their impact on the organization's management process has not been determined. Presently, they have had little effect on the problems addressed in this thesis.

### III. THE G-T PLANNING SYSTEM

The G-T planning system is described in this chapter. The methods and procedures used to formulate the strategic plan and the planning documents will be presented. Further, the link between the strategic planning system, the budget and the budget execution will be discussed.

#### A. THE COMMANDANT'S LONG RANGE VIEW

Figure 3.1 depicts the planning process in Coast Guard Headquarters. It begins with the Commandant and his staff assessing and evaluating the scenario or setting in which the Coast Guard will be operating during the next 15 years. He evaluates challenges that are operational, administrative or budgetary in nature and will have a significant impact on the way the Coast Guard will have to do business in the future. [Ref. 8]

Upon completing this evaluation the Commandant issues the Commandant's Long Range View. The document, issued biannually, is divided into two parts:

- 1) Overview--Briefly describes the scenario in the next 15 years and sets forth The Commandant's direction for addressing it.
- 2) Policy Guidance--Discusses specific issues and policy provided to serve as a focal point for use in developing plans in the service.

The Commandant's Long Range View serves as a basis for the preparation of other Coast Guard planning documents. [Ref. 8]

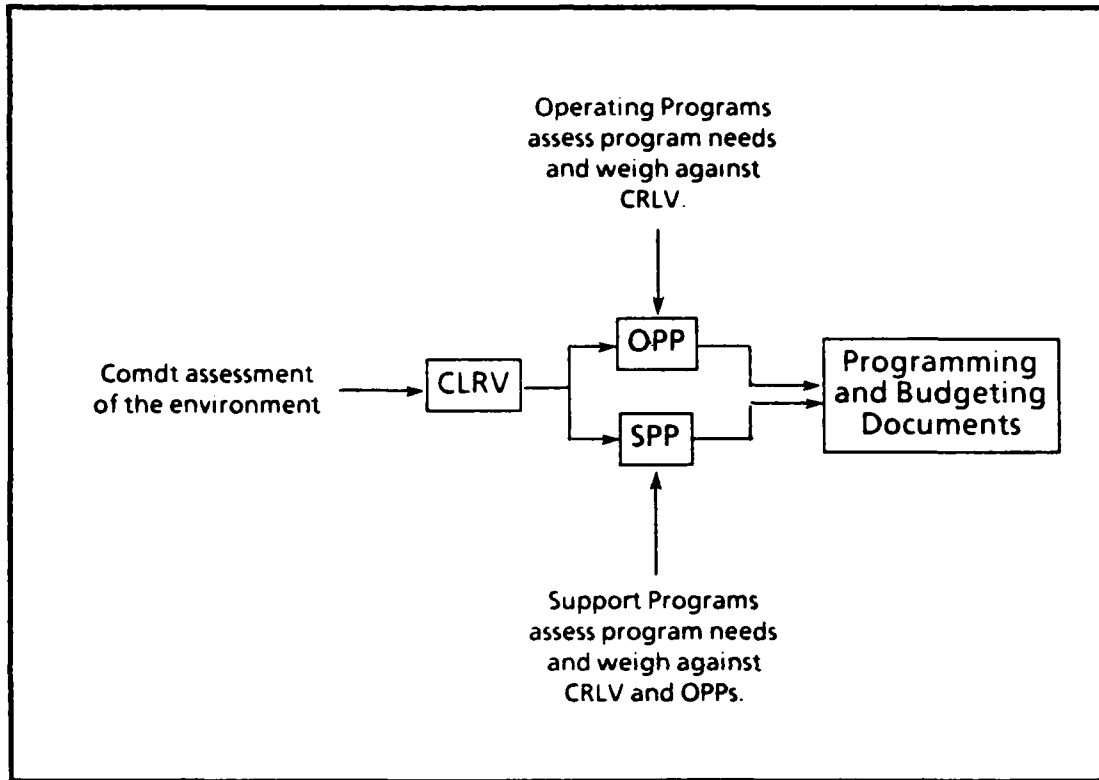

**Figure 3.1: Coast Guard Headquarters Planning Process**

#### **B. THE OPERATING AND SUPPORT PROGRAM PLANS**

G-T is considered to be a Support Program, that is, a program that serves other Coast Guard programs. In contrast, Operating Programs directly serve the public (e.g. Search and Rescue or Law Enforcement).

Support Program Directors provide support or logistic capacity, subject to the needs and requirements of the

Operating Programs Directors. The Operating Program Directors must make sure the needs of their program are made know to the Support Program Directors who provide support to their program. A common source of this information is the Operating Program Plan (OPP). Using the OPPs in conjunction with the Commandant's Long Range View (CLRV), Support Program Directors can develop the Support Program Plan (SPP).

Both the OPP and the SPP translate the forecasts and guidance from the Commandant's Long Range View (CLRV) into five year plans. The Program Directors use these plans to direct the course of their programs and set mid-range budget priorities. These plans, issued annually, must be consistent with the CLRV. They describe the intent of the Program, why it should be done, how and when it will be done, the outputs to be delivered and the analysis of the preferred and other alternatives for accomplishment of the Program's goals. [Ref. 9]

The SPP in G-T is developed by the Strategic Planning Branch of G-TTP. The project is assigned to an O-3 or O-4 grade officer or equivalent civilian. The officer assigned to the development of the plan reviews the previous year's plan making minor modifications to come up with the new SPP. Very little interaction with the Operating Program Directors occurs. Therefore, the plan doesn't change much from year.

It does, however, reflect the current state of projects for future years developed in other G-T divisions.

The SPP is reviewed and revised as it travels up the chain-of-command. These minor modifications are finalized in the the SPP and the document is signed by the office chief. It is then put on the shelf until the next year when it is revised again.

### C. THE LINK TO THE PROGRAMMING AND BUDGETING PROCESS

Figure 3.2 shows how the SPP supposedly links the planning phase to the programming phase. It is intended to

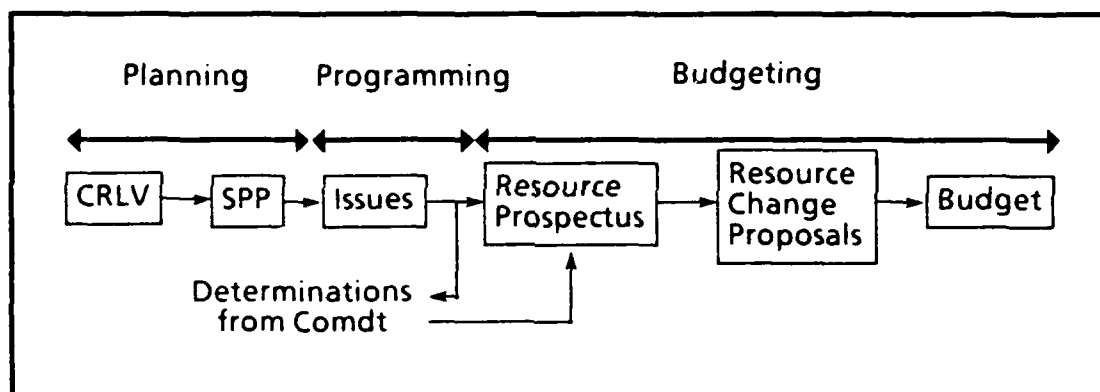

Figure 3.2: The Planning, Programming and Budgeting System

be used to develop the Issues document, the initial document of the programming and budgeting phase. The Issues document is a one to two page document prepared by G-T for the Chief of Staff. The document, which should focus on G-T's potential requirements discussed and approved as part of the SPP, is divided into two parts:

those Issues which require budgetary resources and those that require policy decisions.

During the Issues phase the Operating and Support Program Directors meet one-on-one with the Chief of Staff to reach an understanding on each program's goals and objectives requiring emphasis in the upcoming budget cycle. Note that these are one-on-one meetings with the Chief of Staff. The Chief of Staff must, therefore, have a deep understanding about the direction the Commandant wants to lead the service. He must also be familiar with the capabilities of all the Operating and Support Programs. [Ref. 10]

After each program director meets with the Chief of Staff, the Issues are reviewed by the Chief of Staff's programming staff for budget and policy impact. They are then reassembled to serve as basis for Determinations provided by the Commandant. Determinations will incorporate Commandant decisions on program direction and will identify solutions to problems that require further quantitative development. [Ref. 10]

Upon issuing Determinations, the process of developing the Program Budget is started. The Resource Allocation Branch of G-TPP develops the Resource Prospectus (RP), a one page summary of each problem identified in the Issues phase, the possible solutions, including the preferred solution and the impact of denial. The Resource Prospectus is then



reviewed by the Chief of Staff who prioritizes the proposed project plans in order of their importance in meeting the goals and objectives of the Coast Guard. [Ref. 10]

Resource Change Proposals (RCP) are the final budget documents prepared by the Resource Allocation Branch of G-TTP. Division personnel responsible for projects relating to the problem solutions input the information necessary to arrive at detailed cost analysis, and quantification of benefits. The RCPs then serve as basis for the G-T budget. [Ref. 10]

The programming and budgeting process is designed to be highly dependent on the planning done in developing the SPP. Although the Strategic Planning Branch invests a lot of time and effort in developing the SPP, without direct interaction with top level managers from G-T and the Operating Programs, the document doesn't carry the impact it should. Because the quality of the SPP in G-T is suspect, G-T has, traditionally, used very little of the SPP to develop their budget documents. The SPP serves no useful purpose to G-T except to fulfill a Chief of Staff annual requirement.

#### **D. PROGRAM DESCRIPTIONS**

G-T is not alone in its difficulty with the SPP. Many other Program Directors throughout headquarters have complained to the Chief of Staff about the workload and total volume of paper resulting from the current OPP/SPP

system. Further, they feel that the OPP/SPPs are simply not designed to provide the link to the programming and budgeting system they should.

A major movement is presently underway to change the planning system at headquarters by the Chief of Staff's Plans Evaluation Division. Program Descriptions are to take the place of the current OPP/SPPs. The Program Descriptions are defined as tools used to describe and analyze a program's goals and activities, their implementation and their accomplishments. It is intended to be used as a basis for discussion at Issues.

Before Issues are discussed between the Program Directors and the Chief of Staff, each program must make an in-depth review of the current program status and the approaching trends that may cause change. This process is designed to force the link between the planning and programming phases of the PPBS cycle. Because the system is new and untested, this thesis will not address the management implications of this system. [Ref. 11]

#### **IV. SUCCESSSES AND CURRENT PROBLEMS**

This chapter will examine some of the past successes and current problems in the Office of Command, Control and Communications (G-T). These successes and problems are a direct result of G-T's planning system.

##### **A. SUCCESSSES**

The G-T organization was created in 1981 during a very volatile and uncertain time in the information revolution. Office automation and advances in electronics overwhelmed the Coast Guard before G-T was formed. In the short time since its creation, however, G-T has chalked-up some impressive successes. This section looks at a few of these.

##### **1. The Coast Guard Standard Terminal**

Office automation has been a high priority on G-T's agenda since the creation of the office. In the late 1970's technology moved from centralized mainframes and minicomputers for office automation to distributed personal micro-computers. Apple and IBM were the industry leaders in microcomputer sales during this revolution. Coast Guard shore and shipboard offices began purchasing office automation equipment from these and other companies during the late '70s with little regard for the long term costs of software support and equipment maintenance. The result was

ad hoc purchases of incompatible computer systems and services. G-T saw the need to standardize these purchases to realize the economies of scale that standardization allows.

One of the first actions by G-T was to halt the ad hoc purchase practice of Automated Data Processing (ADP) equipment. They formed local review boards at the district office level called Information Resource Aquisition Boards (IRAB). The boards were to monitor the purchase of ADP equipment ensuring standardization of equipment and services within individual headquarters and district units. This ensured that some economies were realized at the district and headquarters level; however, G-T wasn't satisfied with the result.

G-T began to developed specifications for purchasing of a state-of-the-art microcomputer to be named the Coast Guard Standard Terminal. The standard terminal was to be purchased for distribution throughout the entire Coast Guard. Hardware, software and maintenance equipment and services were to be provided by one source, thus maximizing economies of scale and providing a standard throughout the service.

The specifications for the computer were far advanced from the products IBM and Apple were providing at the time. For instance, multi-server operations in

clustered workstations were specified. This capability has only recently been developed and marketed by IBM and Apple.

Moreover, the software for word and spreadsheet processing, along with software development packages was required to be standard on each machine. The computer purchase was intended to help automate the Coast Guard and give the service the ability to share data between many users with the help of its highly developed communications package.

G-T was very successful in the automation effort. There is no place in the Coast Guard one can go where these terminals aren't the center of operations. One major advantage to this is that wherever an individual is transferred, he is already trained on the office automation equipment. Standardization is often rigid and slow, however, G-T has assured that the system possesses maximum flexibility. This can be proven by the diverse types of users the computer supports today.

Equally responsible for the success of the standard terminal are the wide in-house support services G-T has developed. A Systems Maintenance and Engineering Facility (SMEF) was established to develop software applications in the Coast Guard, as well as act as final acceptance officer for software releases. Information Centers act as customer representatives for computer problems. These centers give advice and support to standard terminal users throughout the

service. Numerous bulletin boards exist to help the user through the myriad of applications and difficulties automation has brought to the Coast Guard.

This has been one of the most challenging and far reaching projects ever given to a Coast Guard Headquarters office. It has also been one of the most successful. It brings the Coast Guard into the 1980's in an equal or better position in automation than most other government agencies, including DOD.

## 2. Interoperability With The Navy

In 1980 the Navy and Coast Guard formed the NAVGUARD Board to look into ways the Coast Guard could be used to help the Navy Reserve in the coastal defense mission of the United States. The Coast Guard and Navy started a new era of cooperation with the formation of Maritime Defense Zones in 1982. Implementing this concept required the Coast Guard to have a high degree of interoperability with the Navy. G-T has taken a big part in this effort ensuring Coast Guard C<sup>3</sup> systems not only meet unique Coast Guard requirements, but also promote interoperability with the Navy.

G-T now works closely with the Navy's SPAWAR Command reviewing interoperability questions. Procedures for operations and equipment requirements are now coordinated through a Coast Guard liaison officer stationed in SPAWAR. This operation has been highly successful in getting Coast Guard equipment requirements funded by DOD and the Navy.

The funding has been extremely important in the recent budget-cutting environment.

The cooperation with the Navy may have also had an indirect effect on the Coast Guard's ability to get money from Congress. The competencies required in working with Congress have never been a strong point in the service. Having an opportunity to learn these skills from a successful agency in this regard has strengthened the Coast Guard's ability to work within the Congressional budget authorization and appropriation system.

### 3. Career Development

The early years of G-T were exciting and challenging to T specialists. They were also very career damaging. The Culbertson study noted:

T officer specialists are faced with continuing dilemmas in career planning and promotability. They may stay in speciality assignments too long or cannot compete effectively with peers for rotational tours. Without "blue-suit" credentials, they risk being passed-over. [Ref. 3: p 35]

Indeed, a higher percentage of T officers have been passed over in past years than the Coast Guard average. Out-of-speciality tours have been rare due to the shortage of T specialists coupled with the pressing needs of the service in the T area.

A couple of years ago a campaign was started to increase the attractiveness of the T speciality, along with the retention and promotability of T officers. In 1987 the

T program selection rate was 76-percent which is competitive with the main stream of the Coast Guard. The promotion rate was a significant improvement over past years' results [Ref. 12]. It has also encouraged officers, previously having reservations about a career in the T speciality, to join the program.

Other successes have been achieved in the area of rotational tours given to T specialists. Today, the T program is nearly adequately staffed and can afford to let officers "punch the blue-suit ticket." Only recently has the T leadership emphasized maintenance of operational leadership and management abilities, as well as technical expertise. No longer do T officers find themselves staying in the speciality against their will. This is a big change in attitude from years past and it seems to be paying the program dividends.

#### **B. CURRENT PROBLEMS**

Despite the successes of the G-T organization, severe leadership and management problems have been identified in the interviews and studies. These problems have a direct effect on G-T's ability to plan in its environment.

Some of these problems can be attributed to the fact that G-T is relatively new and hasn't gone through enough iterations of structure and policy to eliminate them. This section will explore the structure, communication,



credibility, overtasking and planning system problems identified in the research.

### 1. Organizational Structure

The Culbertson Study noted that:

the G-T organization is confusing to people in the field and to many people at Headquarters, even within the G-T organization. [Ref. 3: p 18]

Most of the confusion stemmed from the position that the Planning and Programming Branch (G-TPP) held within the office. G-TPP was and still is a division with staff responsibilities. The human resources and budget planning and allocation functions are unmistakably office level responsibilities, since they cross all division and span all levels of the organization.

Early on, G-TPP was headed up by a group of very powerful individuals. G-TPP was able to take on the office level functions at the division level because of the personal power of its leadership, coupled with its support from top management. G-TPP integrated all the plans of the divisions and divided-up the projects to the divisions. Culbertson noted that G-TPP was too involved in the implementation of the projects as well. G-TPP not only planned the work, but apparently followed-up on projects very closely. [Ref. 3: p 18-19]

The way G-TPP conducted project planning and implementation fostered poor relations between the divisions and G-TPP. When the powerful individuals left the

organization, new, less powerful and less knowledgeable people took their places. It was then that the divisions seized the opportunity to gain more autonomy over their own operations.

The division chiefs cooperated less with G-TTP, only to the extent of getting project funding. They began cutting off information flows to G-TTP. Starting as a reaction to the dictatorial manner in which the original members of G-TTP managed projects, all the divisions contributed in eliminating the integrating force G-TTP provided the organization. G-TTP was powerless to do anything about the situation because there was no formal organizational structure to prevent the other divisions from circumventing G-TTP's authority.

The functional organization of G-T can be related back to pre-T days. Electronics (G-EEE), telecommunications (G-OTM) and data processing (G-FDS) had, historically, been separate. It is the perception of many in the office of T that they still operate that way today. One G-T officer commented that the only thing the T organization did was bring the three functional disciplines together on the same floor of the building, but it did nothing for having them work together. This functional structure gave rise to many communications problems. These problems will be addressed in the next section.

Turf battles often arise within this functional organization. Fighting for resources and project money is an everyday occurrence in G-T. Without control of resources and projects, divisions cannot implement their parochial interests.

## 2. Communications

Lack of communications within the office of T, within Headquarters and with field commands seriously detracts from the program's performance. During the interviews this problem was the most frequently articulated. Further, both the Culbertson and Critical Success Factor studies listed lack of communications as a major obstacle to achieving the optimal program performance.

Culbertson found that the communication problem was a subset of the larger problem of developing a corporate T culture. It stated:

This is actually a subset of the more general problem resulting from a lack of awareness as to just what the T-organization is, what its goals are, how it fits into the overall Coast Guard organization and what it should be doing vice what it actually is doing. [Ref. 3: p 6]

In other words, top management doesn't articulate the purpose and mission of the organization very effectively.

Another important problem is the lack of communications across divisional lines. The Critical Success Factor study found that the interdivisional lines of communications were "limited and in some cases non-existent." Members of divisions know little about what is

going on in T, outside of their own area of expertise [Ref. 4]. Given these facts, it is easy to imagine how the lack of communication and cooperation between divisions can lead to some duplication of project efforts. It has been found in the past that two separate divisions have been working on the same project without the other division's knowledge. Duplication of effort is both wasteful and counter-productive.

Moreover, the communication problem has severely limited management and coordination of projects. With many of today's C<sup>3</sup> projects requiring a coordinated effort in electronics, computers and communications, its is surprising how anything gets accomplished within the office of T.

### 3. Credibility

G-T has had trouble in the past with its image from the customer's viewpoint. Culbertson noted:

...the T-organization is not perceived as being responsive or effective in meeting the needs of program and support managers. [Ref. 3: p 10]

Many people outside the T-organization have looked to G-T for help in developing computer automation of office or shipboard functions. As the requests for assistance in developing these functions increased, G-T was slower in accommodating the individual requests. This behavior resulted in the perceived lack of responsiveness.

Other factors attributing to this perception are the many small failures of automation projects attempted by G-T.

The pure nature of the field of automation in the early 1980's was the development of new untested concepts. As can be expected, developing these new applications from scratch required many years of effort and constant evolution. The misunderstanding of this concept by users expecting the capability to be developed quickly has contributed to the perception of lack of credibility of G-T. [Ref. 3: p 11]

Many small projects which get started in G-T whether computer or electronics fall by the wayside as priorities change. The Critical Success Factor study held that the lack of:

rigorous planning and priority setting within the office has led to incomplete projects. [Ref. 4]

The priority problem will be taken up later; however, it is safe to say that every project that fails to come to fruition hurts G-T's credibility in the long run.

#### 4. Overtasking

Overtasking is taking on so many projects, that it is impossible to finish them all. A contributor to the credibility problem, overtasking has its roots in two areas:

- 1) Prioritization of projects; and
- 2) The organization of G-T (addressed earlier).

The pressures put of T to get the Coast Guard up-to-date with the latest in office automation or electronics gear has made it difficult for individuals to say "no" to taking on new projects. Because there is no priority

setting mechanism to distinguish important projects from non-important ones, all projects seemed important. Project managers were, therefore, unsure of what projects G-T recognized as important. Consequently, project officers became too bogged-down to finish any of their assigned projects. Normally, where choices were made, project managers preferred to work on their own "pet" projects first.

Overtasking was especially prevalent when funds became available at the end of the fiscal year. In many cases, poor planning led to extra work at the last moment to avoid losing funds. The increase in pressure to spend money quickly made it difficult to successfully complete projects without a sufficient planning system in place. Unfortunately, one has never been in place in the past.

#### 5. Planning and Guidance

Strategic planning in G-T has been found to be almost non-existent. The lack of planning and top level guidance in G-T were intertwined with many of the previously mentioned problems and contributed to the overall break down of effectiveness in the organization.

Although the Coast Guard planning system was formally in place, it meant very little in the way business was conducted in G-T. The Support Program Plan (SPP), for instance, was supposed to be an office planning document to describe and analyze the objectives, goals and activities of

the T program. The document was developed at a low level in the organization, based on the Commandant's Long-Range View and sketchy Operating Program Plans (OPPs). Although it was reviewed and signed by the G-T Board of Directors, the document was shelved after fulfilling the "requirement" that it be done annually.

More importantly, the SPP was not in a useful format for G-T to use as a planning document. It was designed to be a Chief of Staff document, used to derive and justify the program's budget. Further, in developing the SPP, G-T used very little input from the operating programs that it is supposed to support. How much use is the SPP if little planning effort is put into the document? Because the SPP was not a functional planning document, the office of T seems to have run its everyday operations without the luxury of a long-range plan.

Planning in G-T is shortsighted with priorities in the office seemingly changing from day to day. The Critical Success Factor study states:

Planning, for the most part, has been focused in the very near term, with most efforts involving more than six month horizons not seen worthwhile given the volatile environment. [Ref. 4]

G-T operates in a reaction mode using what little information it has at the moment to make decisions. The result is a confusing, constantly changing focus, making it impossible to prioritize projects.

Lack of guidance from top level managers has been identified as contributing to the priority problem. A common complaint heard during interviews was that top managers weren't visible on a daily basis. Middle and low level managers feel that the top level managers are so involved in every day operations that it hinders their ability to provide adequate vision about the future. Without the vision from the top, planning is not productive.

### **C. SUMMARY**

This chapter has cited some of the successes and existing problems in the Office of Command, Control and Communications. The data, accumulated during the interviews and from recent studies, is the basis of the information provided. Table 4.1 summarizes the problems and from what sources they have been identified.

Next, a model used for analysis of strategic change management will be presented. This will be followed by an analysis of the G-T planning organization and processes. The rest of the thesis will discuss the ways the G-T managers can improve their strategic planning system.



Table 4.1: Problem Summary

Problem	Source that identified the problem.			
	Culbertson Study	Critical Success Factor Study	Thesis Interviews	
G-TPP is in the wrong place in the organization.	X		X	
Functional organization gets in way of working together.	X	X	X	
Turf battles are normal occurrences.	X		X	
Lack of communications.	X	X	X	
Lack of coordination across Division lines.	X	X	X	
G-T lacks credibility with field units.	X			
There is no formal priority setting mechanism.	X	X	X	
G-T cannot spend fallout funds when they become available.	X		X	
The planning system in G-T is not useful for day-to-day decision making and priority setting.	X	X	X	
The SPP is not developed at the top manager's level of the organization. It doesn't get the proper emphasis.			X	
G-T managers operate in a reactive mode (crisis mgmt).	X	X	X	
Top managers are too wrapped up in the everyday operation of the T program. They do not look at the big picture.			X	

## V. ORGANIZATIONAL ANALYSIS MODEL

In light of future large-scale environmental changes, the Coast Guard will be required to continually reorient itself. It must ensure proper alignment of strategy, structure, human resources and management processes to solve the organization's technical, political and cultural problems. The key to the Coast Guard's success in this endeavor is its strategic planning system. This chapter discusses how the Coast Guard can assess the quality of its planning system to ensure it provides the proper reorientation focus.

Noel Tichy's model for strategic change management can be used as a tool to assist managers in the reorientation effort. The use of the Tichy model for the assessment of the G-T planning system is based on the assumption that organizations with sound strategic planning systems are technically, politically and culturally aligned with their environment. Tichy's model analyzes this alignment.

First, an explanation of how to use the model in analyzing an organization's alignment will be presented. Then, the analysis of G-T will follow, illustrating how this model can be applied.

#### A. HOW TO USE TICHY'S MODEL

The analysis of alignment of the technical, political and cultural systems in organizations is a complex process. However, Tichy's model, described in the Appendix, provides a framework for a comprehensive study of an organization's strategy, structure, human resources and management processes.

Figure 5.1 is the format used in summarizing the analysis of alignments. A judgment is made for each cell of the matrix regarding the amount of change needed to create alignment. Working across the matrix, the alignment is within a system: technical, political and cultural. Working down the matrix alignment is between systems.

Points are assigned to each box in the matrix based on the degree of change needed. A "0" indicates that no change is needed, "1" indicates moderate change and "2" indicates a great deal of change. Once judgments are made for each box the number totals are summed up in both directions and recorded in the margins.

The right margin indicates that amount of realignment required within the technical, political or cultural system. The bottom margin indicates the amount of change required by the component parts of the organization.

The guidelines to be followed in making the assessment of alignment are discussed below.

Table 5.1: Summary Format for Analysis of Alignments

Organizational Components

Core Systems	Mission/ Strategy	Task	Prescribed Networks	People	Process	Emergent Networks
Technical						
Political						
Cultural						

1. Guideline 1

The analysis should follow the description of the model's components and systems in the Appendix. The analysis should be carried out one system at a time (technical, political, or cultural) and then across the systems. This is accomplished by working, first across each row, and then, down each column.

2. Guideline 2

The next step is to evaluate the degree of alignment between the technical, political and cultural systems of the organization.

**B. METHODOLOGY FOR ANALYZING ALIGNMENT WITHIN G-T**

Tichy recommends that the analysis be carried out by a committee of individuals that represents the key power figures and groups most likely effected by the changes. He, further, recommends that each individual in the groups complete a private assessment of the analysis of alignments before sharing it in committee. [Ref. 2: p 166]

In the analysis this procedure was not followed due to the time and resource constraints on the study. The analysis presented here is intended to be an illustration of how G-T managers could use the Tichy model to analyze their organizational alignments.

The analysis was performed by the author without consultation with anyone in the G-T organization. The

results are based solely on the data collected in the interviews, information gathered from Coast Guard and G-T documents, as well as studies conducted in G-T in the past four years.

### **C. THE ENVIRONMENT**

Before performing the analysis of the model components, the environmental factors should be discussed. This section describes the technical, political and cultural systems in the G-T environment.

#### **1. Technical System**

There is no doubt that the electronics, computer and telecommunication fields have undergone many major technical revolutions in the past 25 years. Managing the explosion of information in the Coast Guard's wide variety of mission areas is impossible using manual Command, Control and Communications (C<sup>3</sup>) systems. The Coast Guard's dedicated move towards automated C<sup>3</sup> systems began in 1980 with the creation of the Office of T. Since that time a new generation of computer, the personal computer and several generations of software have become available for use by the service.

High demand for computer services and upgrade in communications equipment from analog to digital have challenged the T-community to be extremely up-to-date on the latest technological changes.

Further, the nature of Command, Control and Communications has changed dramatically as DOD and other agencies with which the Coast Guard works wage their own wars on technological obsolescence. Interoperability has become the watch word of the 80s in C<sup>3</sup>. Yet, with its myriad of sensors and decision support systems, the Coast Guard struggles within itself to integrate these stand-alone, single-missioned systems. Pressure from outside sources to integrate these systems has further complicated the technological equation.

## 2. Political System

G-T operates in an environment which is by definition political in nature. The Coast Guard, in general, is a service oriented organization, funded by Congress and managed by a dedicated group of professional individuals, catering to the needs of multiple constituencies. With this in mind, the political future of the Coast Guard looks very uncertain and ambiguous indeed.

Other environmental factors exist which make it difficult to adapt to the uncertainties in the environment are: [Ref. 13]

- 1) Assigned personnel, military and civilian, limit manager's ability to change or improve the quality of personnel assigned to G-T billets.
- 2) Existing structure and resource allocations are legislated and are difficult to alter. Where change is allowed, the manager is unusually limited in scope of change.

- 3) The legislative system forces planning in G-T and the Coast Guard to center around the annual budget. This process is subject to multiple internal and external influences resulting in uncertainty in budget allocation from year to year. Because of this, long-term planning is difficult due to the lack of long-term funding.
- 4) Policies change with change in Presidential administrations and Congressional leadership. Programs advocated by one elected official may be cut by the next one that assumes the office. The length of term elected officials can force short range planning and execution of programs to show short term results in time for re-election. This factor supports the official's agenda, but may not be in the best interest of the program manager in the service.

The G-T organization, being military and bureaucratic in nature, is politically mechanistic and is slow to adapt to politically uncertain environments. The poor match between G-T and its environment is detrimental to the organization's effectiveness.

### 3. Cultural System

G-T is made up of three different technical fields of expertise. These technical specialities make up one aspect of the culture of G-T.

Electronics Engineers are the most technical oriented of the group. They are hardware driven, leaving the application of their technology to others. They, generally, prefer to work in hard facts and disregard the management implications of their technological breakthroughs.

Computer technicians are the next most technical group. Although they are becoming increasingly user aware,



they have a tendency to become too involved in the efficiencies of their computer systems, disregarding the effectiveness concerns.

Communication specialists or communicators are managers of the telecommunications systems in the Coast Guard. They are the most management oriented of the group and depend heavily on the support of the electronics engineers and computer technicians.

Another aspect of the G-T culture is its operational orientation. G-T operates within the overall cultural environment of the Coast Guard. Officers that specialize in the T field often rotate into non-T specialities every other tour. This is done purposely to cultivate the "blue suit" qualities of T officers. This exposure to the general duty Coast Guard imparts many of the Coast Guard's norms and roles on these officers.

A "blue suiter" is operations oriented, having been assigned to billets, normally, as CO or XO onboard ships or operational shore units. Similar to the Navy's "warfare speciality" billets, these operational tours are seen as essential to the experience of every general duty Coast Guard Officer. This requirement is further enforced by the promotion boards in that those without "blue suit" experience usually don't get promoted.

Besides the operational orientation of most senior officers, there are other norms in the Coast Guard which

attribute to the characteristics of Coast Guard managers. For instance, look at the Coast Guard's motto "Semper Paratus" meaning Forever Ready. The motto itself encourages short range thinking. Unit commanders are taught to be ready to get underway immediately to respond to any emergency. This in itself fosters planning for today or tomorrow and not to worry about next year or the year after that. This short-term view of the world is taken from the field to staff jobs where longer range views of issues are needed.

The concept of independent operation of Coast Guard units helps perpetuate the idea of ownership of "turf" in G-T divisions. Because most Coast Guard units are independent units and are not required to work in groups with other units, sharing resources, the concept of cooperation is not learned or reinforced in Coast Guard managers. This "independent steamer" norm is then carried back to headquarters where lack of communications and cooperation abound.

Not all the cultural characteristics of the organization are negative. Coast Guard Officers have an ability to operate in extremely volatile and uncertain environments. Crisis management is a very useful tool, especially in Washington D.C. The need to be flexible and react to a constantly changing environment is essential for

success in uncertain technological and political environments.

#### D. ANALYSIS OF THE COMPONENTS OF THE MODEL

Given the environment as described and the organization as discussed in earlier chapters, this section analyzes G-T by model component. The analysis draws heavily on the background and facts presented in the earlier chapters.

##### 1. Mission/Strategy

The constantly changing technological environment requires a strategy of constantly assessing the environmental opportunities and threats, the organizational strengths and weaknesses, defining the mission and reallocating resources. G-T does not have a formal system set-up for scanning the outside environment, however, it does perform the other assessments rather well.

For instance, the mission of G-T is:

To enhance the effectiveness of Coast Guard mission performance by acquiring and managing information, telecommunications and electronics resources. [Ref. 14: p 2]

The mission statement is flexible and easily adaptable to changes in the internal and external environment.

Likewise, the Board of Directors, which meets on a regular basis, constantly looks at the organizational strengths and weaknesses and reallocates resources according to the perceived need of the service.

For the most part, the Board of Directors has the major influence in the mission and strategy of the organization. Coalitions, however, are represented by the division officers, who are generally products of their area of expertise. Managing change in G-T is subject to the normal resistance experienced in any organization.

A major weakness of the organization is that mission objectives are not articulated by top management. The development of a culture aligned to the mission and strategy cannot occur without all members of G-T knowing the direction of the organization.

## 2. Tasks

Tasks include environmental scanning activities and strategic planning activities.

Environmental scanning activities in G-T consist of work at the Electronics Engineering Lab and Center. These facilities search for new and emerging technologies and research their application in the Coast Guard. Economic evaluation of these technologies occur at G-T only when a use for these technologies is found.

It was noted earlier that G-T has no formal strategic planning system in effect. Without an understood strategic plan, priorities cannot be set effectively and projects in the organization are mismanaged. The constructs for proper strategic planning, however, are in place. For whatever reason, G-T does not make effective use of them.

The problem of lack of priority setting mechanisms was identified as detrimental to the technical effectiveness of the office. Care must be taken to make sure that the needs of the different technical coalitions in G-T are kept involved if and when any kind of prioritizing process that is developed.

Early in the history of G-T the organization had not developed its own culture. It was made up of the separate cultures that the divisions brought with them from the other offices. Now, however, the organization is gaining its own culture, norms and roles models.

Even so, top management needs to do more to perpetuate this culture. Strong leadership is essential in clarifying and further defining the values of the organization. Without top level managers imparting their philosophy on subordinates, the T culture cannot grow.

### 3. Prescribed Networks

The structure of G-T is along product lines. With the exception of G-TPP, all other divisions are organized to take the best advantage of the G-T strategy. The weakness in this organization is the lack of integrating mechanisms. The newly formed DDCC and Planning councils are designed to perform this function, however, the data on their effectiveness in G-T was not available.

G-TPP is not in a position to perform the integrating or planning functions in the most efficient

manner. It has been difficult for G-TPP to accomplish these assigned staff functions at the division level.

Presently, the power distribution is balanced across all divisions. When G-TPP had the functional responsibilities of resource and project allocation, the balance of power was in G-TPP's favor. However, with the reallocation of divisional responsibilities in the 1986 reorganization, this imbalance was remedied.

An argument can be made that this structure and power distribution makes G-TPP's human resource and budgeting planning functions less effective. These are staff functions which transcend all divisions and levels of the organization. However, moving G-TPP into a staff position may create an imbalance of power with respect to the divisions. Design of the responsibilities and authorities of G-TPP's new position in the organization must be done with power conflicts in mind.

The "independent steaming" culture of many Coast Guard officers gets in the way of cooperation and communication. This characteristic of Coast Guard managers fosters over-protection of turf.

Management style in headquarters must be aligned with the technical and political structure of the organization. A trend of these structures, from the separate divisional units to one integrated organization,

requires that much attention be paid to the development of a cooperative managerial culture in headquarters.

The existence of the various subcultures discussed above requires integration mechanisms to create the overall organizational culture of working together. This is presently being accomplished through the assignment process. Personnel with a computer specialty, for instance, can be assigned to a communications billet, if necessary. The Human Resources Branch should continue this practice to help eliminate the sharp lines of distinction between the three areas of technical specialty.

#### 4. People

G-T has very little problem obtaining skilled technical people to carry out the mission. Its managers are compatible in style with the technical tasks.

Matching political skills of individuals with the political needs of the organization is difficult in the military. The tour length and rank structure places constraints on the flexibility of G-T managers to place individuals with particular skills where they want them in the organization. This area of concern is beyond control of G-T change agents.

Again, the leadership of the T organization must articulate the corporate culture to all members of T. A problem identified earlier was the lack of proper management training given officers at headquarters. G-T must continue

to pursue the education of its officers, not only in the technical areas, but in the management areas as well.

#### 5. Process

G-T has been slow in the past in adapting the office information and planning systems to support the strategy and tasks. However, the constant reevaluation of the organization shows a willingness of the G-T leadership to align process with its environment.

Lack of a priority setting mechanism has been identified as having a detrimental effect on getting projects completed at G-T. A change in this area is essential.

Performance measuring criteria for the services G-T provides are slow in developing also. It is very hard to quantify the types of services the organization provides to the Coast Guard, but efforts are underway to accomplish this.

The reward system in the Coast Guard is standard throughout the service and constrained by law. The promotion system is fairly rigid, providing managers almost no mechanism to immediately reward individuals who perform exceptionally. The only way a manager can affect a promotion of an individual is through use of the performance evaluation system. These reports are used by promotion boards in making decisions to promote individuals to the next rank when their time comes up to be evaluated.



Further, they are used by the assignment officers for making assignments to rotational tours. The performance evaluation system, however, results in long-term benefits for the office, not immediate results.

Managing the politics of appraisal is not a problem since a single manager's appraisal of an individual does not carry much weight with the promotion board.

Managing the politics of information flow is a consideration that top managers should concern themselves with in formulating a planning system. No one division has all the information, however, it is important that they all participate in the planning process so that strategic decisions can be made with adequate information.

Process in the cultural system consists of selecting people with the skills to build and solidify the culture and developing a reward system that reinforces the culture.

The T field has had problems in the past getting personnel willing to pursue careers in the T field. However, there is evidence that this trend is changing. Tremendous gains have been made in career development and retention through the planning efforts of the Human Resources Branch and the efforts of the latest office chief. The T organization is gaining a reputation of being a professional, career enhancing subspecialty.

## 6. Emergent Networks

G-T exists in a military environment, characterized by formal chains of command and rank structures. Although some emergent networks evolve, they, for the most part, are healthy, assisting in the effectiveness of members in the networks.

However, mismanaging the politics of emergent networks can affect the effectiveness of organizations of this size. Management of the different coalitions must be in forefront of the organizational designer's mind and G-T is no exception.

Throughout the Coast Guard friendships and effective cultural networks exist service-wide. The size of the Coast Guard and the T organization make it easy to cultivate the family atmosphere. This atmosphere should continue and will help to reinforce the corporate culture of cooperation that the T organization needs to be effective.

### D. ALIGNMENT OF THE THREE SYSTEMS

The increase in technical uncertainty in recent years has promoted changes in the need to increase information-processing capability. G-T must increase its ability to scan the environment and create integrating mechanisms to accommodate the task interdependence of today's  $C^3$  environment. This will involve changes in organizational structures and processes.

These changes in the technical system must be accomplished, keeping mind the political and cultural changes that may obstruct the change effort. G-T leaders must evaluate the organization's ability to manage the power to allocate resources and decide on goals in an uncertain environment. This becomes extremely difficult in bureaucratic organizations and requires a change from the politically mechanistic organization of the military to a more politically organic one. Keeping in mind the limitations on managers to change the organization radically, G-T can move towards setting up informal integrating mechanisms to deal with the political uncertainty.

Culturally, the top leadership should articulate more the direction of the organization. The values to be shared, the objectives worth striving for and the beliefs the employees of G-T should be committed to are all part of the culture that must be communicated. Cultural congruence and consistency is essential given the environment.

#### **E. SUMMARY OF RESULTS**

Table 5.2 summarizes the results of the analysis of G-T. Note that the areas diagnosed as needing the most change are in the following organizational components:

- 1) Mission/strategy in the political system. Influence in the formulation of strategy must lie with all members of the organization. Further, better control must be maintained over the behavior of the different coalitions in G-T once strategic decisions are made.

Table 5.2: Summary of Analysis of Alignments for G-T

Organizational Components

Core Systems	Mission/Strategy	Task	Prescribed Networks	People	Process	Emergent Networks
Technical	1	2	1	0	1	0
Political	2	2	1	1	2	1
Cultural	1	1	2	0	1	0
	4	5	4	1	4	1
						19

- 2) Tasks in the technical and political systems. Outside environmental scanning activities must be improved. Strategic planning activities in G-T are virtually non-existent and need further development. Moreover, the organization must be able to lobby and influence outside external constituencies to be successful in carrying out its plans. Internal coalition management must be improved as well to eliminate in-fighting.
- 3) Prescribed networks in the cultural system. The management style of top managers in G-T are not aligned with the technical and political structure. Integration of the different coalitions and sub-cultures in the organization is essential for managers to maintain alignment with the environment.
- 4) Process in the political system. Administration of the reward system needs to be improved to reinforce desired behaviors. The politics of information control and the planning and priority setting processes must also be managed better.

The areas needing no change at all were in the organizational components of people and emergent networks. It is felt by the author that these are two areas that military managers have little influence over. Military managers have been conditioned to do the best with the skills of the personnel they are given and they do a fairly good job at utilizing these skills.

What do these results mean with regard to the strategic planning system in G-T? Given the premise that an organization that is well aligned with its environment has a good planning system, the results indicate that G-T needs to make some improvements in its strategic planning system.

The components of the organization that require major changes are indicated above. This analysis illustrates how

G-T managers can pinpoint where to concentrate their change efforts. The following chapter uses this analysis to formulate recommendations for improvements to the strategic planning system in the office.

## VI. RECOMMENDATIONS FOR IMPROVEMENT

The analysis in the previous chapter highlights weaknesses in the G-T management and planning systems that inhibit the organization's ability to reorient its strategic posture. This chapter recommends changes in the management and planning systems which might improve the existing planning system in G-T.

The recommendations are based on the analysis presented in Chapter V and are the author's solutions to the problems indicated.

### A. COUNCILS

G-T should establish mechanisms for and encourage the practice of cross-divisional cooperation and planning through the use of integrating committees or councils. Chapter II discussed the three councils already in place in the G-T organization. The councils (refer to Figure 2.7) were formed as a result of recommendations provided to G-T in the Critical Success Factor study. The councils will help eliminate problems in many of the areas previously discussed.

First, the council mechanism makes the organization more politically organic by increasing G-T's bargaining capacity. In a politically uncertain environment, this is important.

The councils accomplish this by providing a mechanism for the three product-line divisions to get together to discuss problems and bargain for project resources.

The council structure encourages communication between divisions, thus increasing the information processing capabilities of G-T. The councils have been formed to specifically combat this problem. By providing a mechanism to channel information flows between divisions, uncertainty about what is going on in the organization is reduced. The cross-talk will be useful in increasing the environmental scanning capabilities of the organization. The diversity of technical expertise in the divisions is useful in processing information about future technologies, future service needs and future management trends. These can be discussed, processed and disseminated easier through the use of the councils.

The councils also encourage cooperation between divisions. The information channels open the door for resource sharing between divisions. The problem of two divisions working on the same project will likely occur less, as long as the information channels are truly open.

Another problem that the councils address is the lack of a priority setting mechanism. It will be easier to formulate priorities through this integrated approach. Although priority setting must ultimately come from the top, the councils can provide meaningful, integrated guidance to



help G-T arrive at priorities the entire organization can understand and live with.

Finally, the councils helps to cultivate a G-T corporate culture. The integrating mechanism brings together the three sub-cultures of electronics, computers and communications. Cultural values can be discussed freely and constructively. Organizational norms and roles can be learned and passed laterally throughout the organization. The entire organization will, therefore, develop a homogeneous cultural identity which makes translates into higher productivity and better organizational effectiveness.

#### **B. NEW PLANNING SYSTEM**

A functional link between the strategic planning system and the programming and budgeting process needs to be established. Chapter III discussed the Chief of Staff's efforts to overhaul the Coast Guard Headquarters planning system. G-T should use this opportunity to discard the poor planning emphasis it had in the past and develop new planning procedures in the office. Figure 6.1 shows how this can be accomplished.

Through the Planning Council, divisional needs can be integrated and coordinated. Although closer ties with the Operating Programs are needed, the planning council can provide a wealth of resources and experience to make strategic planning useful.

Information from the field, Operating Programs and the G-T divisions can be integrated at the planning council

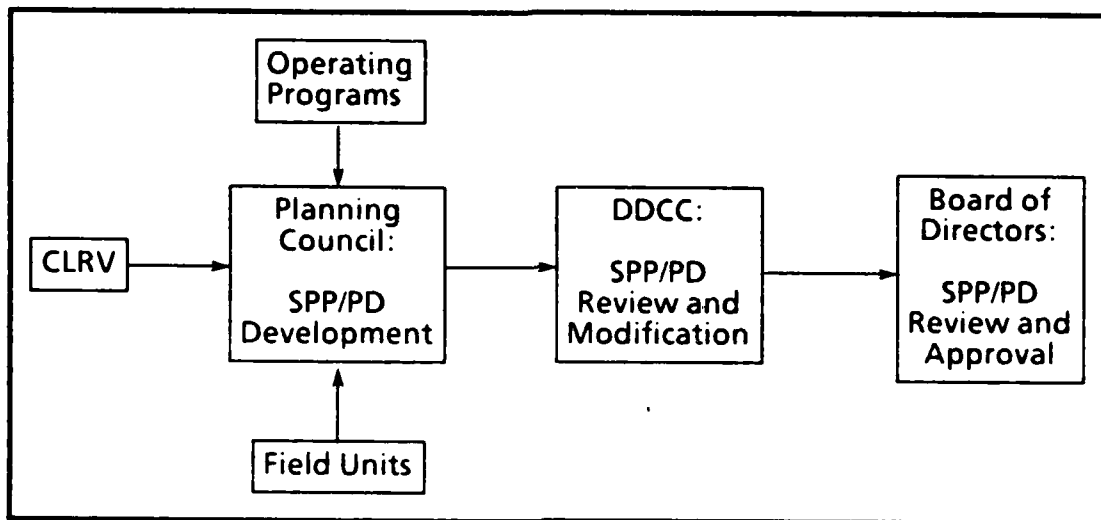

Figure 6.1: The Proposed Planning Process

level and passed up to the DDCC. The DDCC can then review the planning document, interjecting their special needs and expertise.

Finally, the document is passed to the Board of Directors. Here strategic planning decisions should be made using all the information passed up through the chain-of-command and the councils. Coupled with the BOD's top level view of the organization, a first rate strategic plan and planning document can be developed.

The key to the success of the planning system, however, is its use in the programming and budgeting system. The Chief of Staff has committed to using the Program Description, each offices strategic planning document, as

the basis for issues and the budget. This will help force G-T to develop the Program Description into as a useful office plan, using it throughout the budget process.

A side benefit is that everyone in the organization will know the direction G-T is headed making priority setting more certain.

### **C. KEEP G-TPP WHERE IT IS**

Although G-TPP should logically reside as an office staff, there is too much resistance from all levels of the organization for the move. The political and power issues cannot be overcome at this point in time.

Instead, G-TPP should be used to facilitate the strategic planning process described above. Sitting on the councils and providing clerical support, the division can be useful in developing the written documents and executing the plans. G-TPP, however, should not be the only player in strategic planning.

G-TPP's allocation of resources and budgeting functions should be closely supervised and supported by the office chief. The G-TPP Division Chief should also have the seniority to settle disputes between other division chiefs. A senior Coast Guard Captain (O-6) should be assigned to the job.

Human Resource Planning is a key office function that has received much attention and support in recent years.

The present structure seems to be working in this regard. However, top management must not become content with the successes of late. The T organization continues to grow and needs to attract more personnel resources. By strengthening the T career sub-specialty, through increasing the promotability of officers and assignment to career enhancing jobs, top management can ensure a steady growth in the T field.

#### **D. INCREASE TOP MANAGEMENT'S VISIBILITY**

Top management needs to be more visible and accessible to lower levels of the organization. This management technique can help top managers keep in touch with what's going on in the office, first hand. It can also help them cultivate the preferred culture by spreading their philosophy directly to organizational members. This shows subordinates that top management is interested and involved in what they are doing.

Common complaints in the interviews were that top management was never seen around the office. They were viewed as being so busy attending to the details of everyday operations that they didn't have the big picture. However, in actuality, top managers had the big picture. This can be attributed to the manager's position and experience in the organization. The perception of their inattentiveness, however, was very real in the minds of lower level managers.

As a result of this perception, overall organizational effectiveness was not being optimized.

Top managers need to employ a technique of "management by walking around" (referred to as MBWA) [Ref. 15]. A principle advocated by Tom Peters, this simple and obvious technique can do wonders for organizational effectiveness. Unfortunately, this simple and obvious technique is neglected in the Coast Guard. Reasons for this vary from the hierarchical culture of the military to the simplicity of the technique.

MBWA can help G-T managers keep in touch with their environment by familiarizing them with what problems exist in the office and in the field. MBWA also provides a means by which the cultural values and norms of the organization can be spread. Coming directly from top management's example, the culture is more visible, and therefore, can be adopted by the rest of the organization more readily. Finally, MBWA shows that top management is interested in everything the organization does. It sends the message that everyone is important. Even the smallest function, done well, improves the overall effectiveness of the organization.

The effectiveness of the MBWA technique has been proven time and again in companies like Federal Express and the Louisville Redbirds Minor League baseball team [Ref. 15]. It's time the Coast Guard employed it.

## E. REWARDS

Rewards should be given to reinforce desired behavior. For example, recognizing people who practice and encourage cooperation or planning when managing projects can reinforce these types of behavior. Too often the organization recognizes undesirable behavior, using it as an example of what not to do.

The recognition can come through meetings of all G-T personnel or write-ups in the weekly T Staff Notes. This can go a long way towards letting people know what top managers perceive as beneficial to the effectiveness of the organization.

Better use of the performance evaluation reports can also help reinforce desired behavior. Creative ways of writing up accomplishments that exhibit good long-range planning or cooperative efforts between division must be found and used in evaluating performance.

Likewise, the assignment process can provide needed rewards for outstanding performance. Because the Human Resources Branch has a strong influence in the assignment process, it can be used as a vehicle for rewarding these behaviors. Career enhancing and desirable jobs can be awarded to good performers.

However, care must be taken to maintain the technical and managerial competency of the T organization. Desirable

jobs, for instance, must not be assigned as rewards to top performers if the jobs are training grounds for T specialists who need the experience.

## VII. CONCLUSIONS

The study researched the possibility of improving Coast Guard planning. Because of the time and resource constraints, the Office of Command, Control and Communications (G-T) was chosen as a representative unit of the Coast Guard to serve as a sample to study the planning system. It was felt that G-T with its volatile environment would be an excellent of how the Coast Guard would be required to plan in the future.

It was dicovered that G-T had real problems with its planning system. The organization was slow to react to the changes in its environment and did not possess either the structure or management processes to adequately perform strategic planning.

Noel Tichy's model was demonstrated to be a useful tool in identifying the organizational components in G-T on which managers should concentrate their change efforts. The Tichy model provides guidance to changes in the planning system to ensure the alignment of organizational components and the technical, political and cultural systems with the environment.

It is important to recognize that other models can be used to identify an organization's planning weaknesses. Managers should be aware that the use of a model such as



Tichy's model helps guide them through the complex analysis process. Without the models, the analysis would most likely be incomplete.

Recommendations for improvement of the G-T planning system were:

- 1) Establish management councils to provide the integrating mechanism needed for strategic planning.
- 2) Promote a new planning system that links strategic planning with operational plans.
- 3) Maintain the present formal structure in G-T, but emphasize cooperation and communication between divisions.
- 4) Employ "Management By Walking Around" techniques by the top office managers to give them more exposure to their environment.
- 5) Use the reward system to reinforce desired behaviors. This may require some innovative techniques because the formal reward system is too rigid and controlled.

The author believes that these changes will emphasize the importance strategic planning in G-T.

The results of the study in G-T can probably be applied to other areas of the Coast Guard. It is safe to say that the Coast Guard as a whole has a problem with strategic planning given the technical, political and cultural systems used to manage its programs. The techniques used in the study to identify weaknesses in G-T's planning system can reasonably be applied to any other organization within the service.

It is not unusual for organizations to have trouble with strategic planning. The present day environment is

turbulent and the future environment looks to be even more complex. The Coast Guard has had some remarkable successes in the past two hundred years and will most likely have many more. The employment of a strategic planning system that enables the organization to move forward would facilitate more successes and help to reduce the problems.

### LIST OF REFERENCES

1. Stoner, J.A.F. and Wankel, Charles, Management, 3rd Ed., Prentice-Hall Inc., 1986, p 9.
2. Tichy, Noel M., Managing Strategic Change, John Wiley, 1983.
3. U. S. Coast Guard, Command, Control and Communications Review Study, U. S. Coast Guard Headquarters, Washington, D.C., March 22, 1984.
4. U. S. Dept of Transportation, Transportation Systems Center, and Index Group, Inc., U. S. Coast Guard, Office of Command, Control and Communications, Critical Success Factor Study Final Assessment, Washington, D.C., January 22, 1988.
5. U. S. Coast Guard, "Budget in Brief", Commandant's Bulletin, p 7, February 25, 1988.
6. U. S. Naval Institute, "Coast Guard Command Structure", Proceedings, Naval Review Issue, May 1988.
7. Commandant (G-T), Memorandum 5400 to G-CCS, Subject: Reorganization Request, Enclosure (1), January 17, 1986.
8. U. S. Coast Guard, Commandant's Long Range View, COMDTINST M16014.1C, Washington, D.C., October 1, 1986.
9. U. S. Coast Guard, Planning and Programming Manual, COMDTINST M16010.1A, Washington, D.C., March 1, 1986.
10. U. S. Coast Guard, Office of Command, Control and Communications, Standard Operating Procedures Manual-Draft, p 3-16 - 3-18, Washington, D.C., April 8, 1988.
11. Commandant (G-PTE), Memorandum 16015.1 to G-TTP, Subject: Coast Guard Planning System, Enclosure (2), March 4, 1986.
12. Commandant (G-T), Letter 1000 to Lt Francis X. Irr, Jr., USCG, Subject: G-T Roster and Career Information, December 1, 1987.

13. Hosmer, LaRue T., Strategic Management, p 420-421, Prentice-Hall, Inc., 1982.
14. Commandant (G-Td), G-T Critical Success Factor Study-Status Report, p 2, Washington, D.C., March 14, 1988.
15. Peters, Thomas J. and Austin, Nancy K., A Passion For Excellence, Random House, 1985.

## APPENDIX: TICHY'S MODEL FOR STRATEGIC CHANGE MANAGEMENT

Tichy views organizations as social networks. They are composed of people and groups that join together in a variety of relationships. Many of these groups are not joined directly while other have multiple relationships. The perception he is concerned with is how these relationships are patterned and the causes and consequences of these relationships.

Tichy's social network organizational model aims to:

- 1) Integrate technical, political and cultural organizations.
- 2) Point to pragmatic diagnostic questions.
- 3) Help formulate specific change strategies for use in the technical, political and cultural areas.

The model analyzes three systems in the organization: the technical, political and cultural system. The analysis of information networks--who exchanges information with whom--provides the concepts and tools for technical analysis. Analysis of influence networks--seeing who influences whom about what--provides the concepts and tools for political analysis. Finally, the analysis of the friendship relationships provides insight into the way values and norms of a culture are disseminated and reinforced. [Ref. 2: pp 71-73]

## A. COMPONENTS OF THE MODEL

The components Tichy's of the network model are shown in Figure A.1. They are used to guide the strategic management change process. The model is based on the assumption that organizational effectiveness (indicated here as Output) is a function of the characteristics of each of the components of the model, as well as a function of how the components interrelate and align themselves into a functioning system. This section will examine each component of Tichy's model. [Ref. 2: pp 74-94]

### 1. Inputs

Inputs are the background factors out of which an organization arises and in which it operates. These factors are the organization's history, environment and resources.

The history of an organization and how it came to be is useful in understanding how the organization works. Organizations are often prisoners of their own histories. Therefore, history can uncover some interesting material which explains how things are today and may be in the future.

Every organization is embedded in an environment that provides opportunities and constraints. The environment has a large impact on the performance of the organization. Reducing the uncertainty of the environment should be a major goal of organizations that wish to

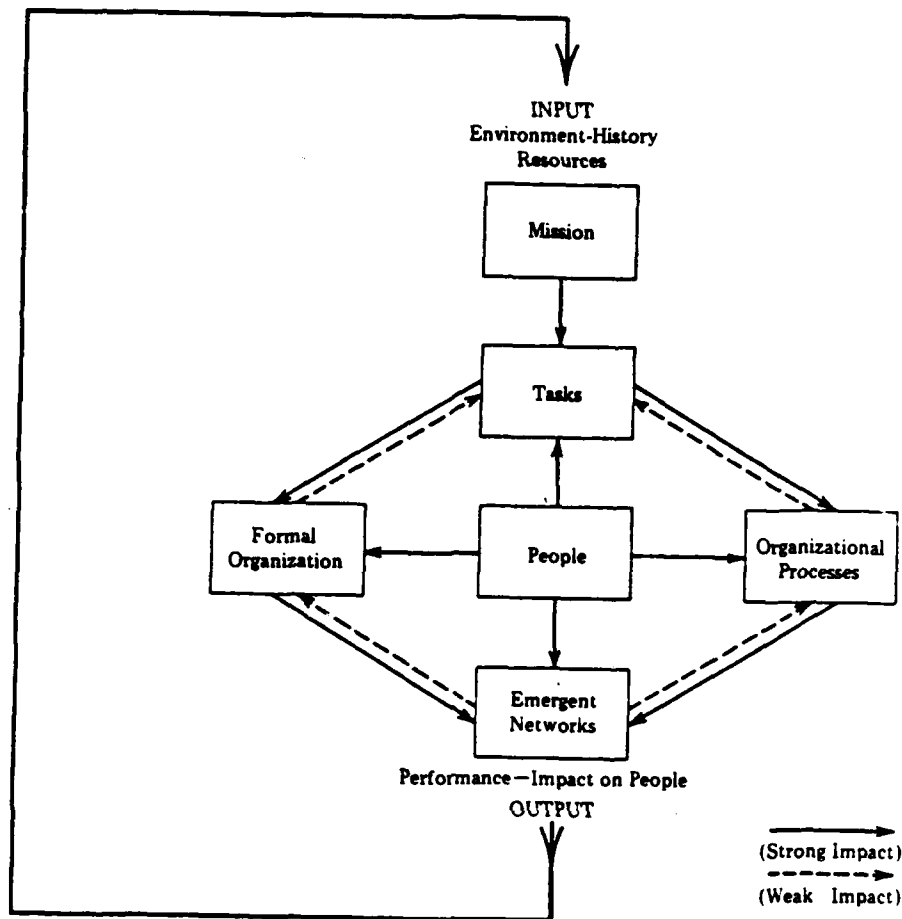

**Description of Components**

**Mission/Strategy:** This includes the organization's reason for being, its basic approach to carrying out its mission, its strategy, and its criteria for effectiveness.

**Tasks:** This refers to the technology by which the organization's work is accomplished.

**People:** This includes the characteristics of the members of the organization including background, motivational patterns, managerial style.

**Formal Organization:** This refers to the explicitly designed social structure of the organization. It includes the organization of subunits, communication and authority networks, as well as structural mechanisms for integrating the organization.

**Organizational Processes:** These are the mechanisms (communication, decision making, conflict management, control, and reward) which enable the formal organization to carry out the dynamics of work.

**Emergent Networks:** These are the structures and processes which, although not planned or formally prescribed, inevitably emerge in the organization.

**Figure A.1: Tichy's Organizational Model**

maximize their performance. Components of the environment are the industry, political climate, social expectations, economic climate inside and outside the organization, as well as the expectations of employees in the organization.

Resources are the third category of organizational input. Resources include the organization's capital, technological capabilities, people, including the skills they possess, reputation and goodwill.

## 2. Mission/Strategy

Mission is the organization's reason for being. It is determined by top managers to meet the needs of its stakeholders. Large organizations may have many missions due to the multiple coalitions or stakeholders that exist.

Strategy is the organizations's basic approach to carrying out the mission. It includes a set of guidelines, which determine the organization's future objectives. Strategy is often neither explicit nor agreed upon by organizational members.

## 3. Tasks

Tasks are specific activities which the organization must perform in order to carry out its mission and strategy. Tasks differ greatly from organization to organization. They depend on the amount of interaction required between people, variety of activities, routineness of tasks and breadth of skills involved in the task.



#### 4. Prescribed Networks

Prescribed Networks refer to the definition of jobs and the expected interrelationships among jobs. They define the structure of the organization and are, typically, represented by organization charts. The organization of communications and authority networks, as well as structural mechanisms for integrating the organization are included in prescribed networks.

#### 5. People

People of the organization can be characterized by the following:

- 1) The skills and interests individual members of the organization have.
- 2) Individual members' styles of learning.
- 3) The values and assumptions individual members hold, especially their expectations about leadership.
- 4) Individual members' preferences for variety, definition and structure, and individual challenge. In short, the individuals' motivation.

#### 6. Process

For people to carry out their prescribed tasks in organizations there must exist dynamic processes of communications, control, problem solving, reward and conflict management.

Communications is the central process that makes the organization work. Because organizations are information-processing mechanisms, information is the glue by which the

organizations is held together. Communications networks transport all types of social task oriented information.

Control processes are the tools for observing and providing information to make the necessary adjustments when problems arise. These processes exist in two types: one aimed at catching errors and the other aimed at collecting problem-solving information.

Reward system processes are crucial to driving the organizations towards change. They are what motivates individuals toward new goals. These are important tools for strategic change management.

#### 7. Emergent Networks

Organizations develop extensive informal or emergent structures and processes as a result of human interaction. These networks of relationships and processes emerge because individuals tend to:

- 1) Formulate, re-formulate and interpret the mission.
- 2) Understand, abide by and/or change the prescribed organization and processes.
- 3) Use, abuse and alter technology.
- 4) Respond to changing environmental conditions.

As a result, a new set of unplanned and often unanticipated structures and processes emerges.

These emergent networks may either hinder or help the accomplishment of the organizational mission.

## 8. Output

Tichy looks at output as organizational effectiveness. Effectiveness has three components:

- 1) Goal optimization--Evaluates the organization in relationship to its intended behavior.
- 2) Systems perspective--Emphasizes the importance of viewing the organizations as an open system with interdependent parts. These parts must be in harmony if effectiveness is to be achieved. The organizations must exhibit alignment between the technical, political and cultural systems.
- 3) Behavioral emphasis--Focuses on the interface between the organization and its members. In other words what impact does the organization have on its members in terms of satisfaction, quality of working life and growth opportunities.

### B. INTERRELATIONSHIPS BETWEEN MODEL COMPONENTS

The goal of Tichy's change management is to align the components of an organization technically, politically, and culturally. Figure A.2 shows what needs managing in this change process. Tichy believes that if there is harmony between these components and systems, the organizational effectiveness will be optimized.

Because organizations are dynamic and exist in changing environments none of the three systems are ever stable. Achieving strategic alignment is the responsibility of the leaders of the organization. Knowing when these systems are aligned, however, is difficult.

The four strategic alignment tests Tichy advocates to measure this alignment are discussed below: [Ref. 2: pp 124-138]

**Managerial Tools**

Managerial Area	Mission and Strategy	Tasks	Prescribed Network	People	Processes	Emergent Networks
Technical System	Assessing environmental threats and opportunities Assessing organizational strengths and weaknesses Defining mission and fitting resources to accomplish it	Environmental scanning activities Strategic planning activities	Differentiation: organization of work into roles (production, marketing, etc.) Integration: recombining roles into departments, divisions, regions, etc. Aligning structure to strategy	Selecting or developing technical skills and abilities Matching management style with technical tasks	Fitting people to roles Specifying performance criteria (or roles) Measuring performance Staffing and development to fill roles (present and future) Developing information and planning systems to support strategy and tasks	Fostering the development of information returns which facilitate task accomplishment
Political System	Who gets to influence the mission and strategy? Managing coalitional behavior around strategic decisions	Lobbying and influencing external constituencies Internal governance structure Coalitional activities to influence decisions	Distribution of power across the role structure Balancing power across groups of roles (e.g., sales vs. marketing, production vs. R&D, etc.)	Utilizing political skills Matching political needs and operating with organizational opportunities	Managing succession politics (who gets ahead, how do they get ahead) Decision and administration of reward system (who gets what and how) Managing the politics of appraisal (who is appraised by whom and how) Managing the politics of information control and the planning process	Management of emergent influence networks, coalitions, and cliques
Cultural System	Managing influence of values and philosophy on mission and strategy Developing culture aligned with mission and strategy	Use of symbolic events to reinforce culture Role modeling by key people Clarifying and defining values	Developing managerial style aligned with technical and political structure Development of subcultures to support roles (production culture, R&D culture, etc.) Integration of subcultures to create company culture	Utilizing cultural leadership skills Matching values of people with organization culture	Selection of people to build or reinforce culture Development (socialization) to mold organization culture Management of rewards to shape and reinforce the culture Management of information and planning systems to shape and reinforce the culture	Fostering friendship and affective networks, coalitions and cliques to shape and reinforce the culture

**Figure A.2: Tichy's Managerial Tools**

## 1. Technical Alignment

Technical alignment strives to match organizational designs to the complexity and uncertainty of environments and the organization's technology. The following principle applies:

An organization is technologically effective to the degree that the uncertainty it faces matches its capacity to process information and to eliminate the uncertainty. [Ref. 2: p 126]

Uncertainty arises because information required to complete tasks exceed the information processed. The sources of uncertainty in organizations are: environment, tasks, and task interdependencies.

Two options are available to deal with uncertainty:

- 1) Reduce the uncertainty. This is accomplished only by changing the organization's relation to its environment; or
- 2) Change the tasks or task interdependencies. This implies altering the organization's information-processing capabilities.

Care must be taken when adjusting the technological system because it may have detrimental effects on the political or cultural systems.

## 2. Political Alignment

Political alignment is based on the view that organizational behaviors are shaped by political bargaining which will guide the allocation of organizational resources. The political drive of an organization is for survival and growth. Survival and growth depend on continuing exchanges

between members of the organization of labor, money or support. The more an organization depends on the contributions of one individual or group, the more power that individual or group exerts on the allocation process.

The objective of the political test of alignment is to reduce or manage uncertainty. The focus is on the uncertainty surrounding the power to allocate resources and decide on the organization's goals. There two ways of dealing with this uncertainty:

- 1) Alter the uncertainty. This entails changing the political environment by forming political coalitions to maintain control; or
- 2) Develop a consensus over goals and means. This requires adjustments in the fit between political bargaining needs and political bargaining processing capacity.

A political adjustment may also trigger technological or cultural adjustments.

### 3. Cultural Alignment

Cultural alignment is harder to define, and therefore, harder to identify. However, it is far too important a part of every organization to ignore.

Cultural alignment or congruence is a product of two conditions:

- 1) A majority of the organizational members should accept the beliefs, endorse the values, and abide by the norms; and
- 2) Individual members should be made aware that the beliefs, values and norms have collective support.

Cultural congruence varies over time with the change in the environment. Organizations must have ways to reduce incongruence or have ways of managing incongruence. (An analogy can be made between incongruence and uncertainty.)

Testing the cultural alignment of the organization is done by analyzing amount of cultural uncertainty the organizations faces and the managerial responses to the cultural uncertainty. In general, as cultural incongruence increases, the need for cultural adjustments increases.

There are two way of dealing with cultural incongruence:

- 1) Change the organization's relation to the environment or change the diversity of the organization's people; or
- 2) Alter the organizations ability to adjust to incongruence.

As with the other systems, changes in the cultural system may trigger changes in the technical system or political system.

#### **4. Testing Consistency between the Three Systems**

The basic task for change managers is to make sure that the three systems not only are aligned from within, but also between the systems. Organizations that constantly attend to the technical issues, for instance, often give too little attention to the political or cultural issues.

Most organizations have a dominant system. For instance, religious organizations are dominated by cultural

systems, political parties by political systems and manufacturing firms by technical systems. A rule of thumb is that the dominant system is usually in balance with the environment, but the subordinate systems are likely to be out of balance.



INITIAL DISTRIBUTION LIST

	No. Copies
1. Defense Technical Information Center Cameron Station Alexandria, VA 22304-6145	2
2. Library, Code 0142 Naval Postgraduate School Monterey, CA 93943-5002	2
3. Dan C. Boger, Code 54Bo Department of Administrative Sciences Naval Postgraduate School Monterey, CA 93943-5000	1
4. Roger D. Evered, Code 54Ev Department of Administrative Sciences Naval Postgraduate School Monterey, CA 93943-5000	1
5. Benjamin J. Roberts, Code 54Ro Department of Administrative Sciences Naval Postgraduate School Monterey, CA 93943-5000	1
6. Commandant (G-PTE) 2100 2nd Street, S.W. Washington, D.C. 20593-0001	2
7. LT F. X. Irr Commander (dtm) Eighth Coast Guard District Hale Boggs Federal Building 500 Camp Street New Orleans, LA 70130-3396	3
8. LT M. W. Cerasale SMC 1443 Naval Postgraduate School Monterey, CA 93943-5000	1