

AD-A196105

BRL-TR-2911

TECHNICAL REPORT BRL-TR-2911

BRL

1938 - Serving the Army for Fifty Years - 1988



ELECTRICAL FEEDTHROUGH DEVICE
FOR USE IN A BALLISTIC ENVIRONMENT

R. E. TOMPKINS

MAY 1988

APPROVED FOR PUBLIC RELEASE; DISTRIBUTION UNLIMITED.

U.S. ARMY LABORATORY COMMAND

BALLISTIC RESEARCH LABORATORY
ABERDEEN PROVING GROUND, MARYLAND

DESTRUCTION NOTICE

Destroy this report when it is no longer needed. DO NOT return it to the originator.

Additional copies of this report may be obtained from the National Technical Information Service, U.S. Department of Commerce, Springfield, VA 22161.

The findings of this report are not to be construed as an official Department of the Army position, unless so designated by other authorized documents.

The use of trade names or manufacturers' names in this report does not constitute indorsement of any commercial product.

REPORT DOCUMENTATION PAGE

Form Approved
OMB No. 0704-0188

1a. REPORT SECURITY CLASSIFICATION Unclassified		1b. RESTRICTIVE MARKINGS		
2a. SECURITY CLASSIFICATION AUTHORITY		3. DISTRIBUTION / AVAILABILITY OF REPORT		
2b. DECLASSIFICATION / DOWNGRADING SCHEDULE				
4. PERFORMING ORGANIZATION REPORT NUMBER(S) BRL-TR-2911		5. MONITORING ORGANIZATION REPORT NUMBER(S)		
6a. NAME OF PERFORMING ORGANIZATION US Army Ballistic Rsch Lab	6b. OFFICE SYMBOL (If applicable) SLCBR-IB-B	7a. NAME OF MONITORING ORGANIZATION		
6c. ADDRESS (City, State, and ZIP Code) Aberdeen Proving Ground, MD 21005-5066		7b. ADDRESS (City, State, and ZIP Code)		
8a. NAME OF FUNDING / SPONSORING ORGANIZATION	8b. OFFICE SYMBOL (If applicable)	9. PROCUREMENT INSTRUMENT IDENTIFICATION NUMBER		
8c. ADDRESS (City, State, and ZIP Code)		10. SOURCE OF FUNDING NUMBERS		
		PROGRAM ELEMENT NO.	PROJECT NO.	TASK NO.
11. TITLE (Include Security Classification) Electrical Feedthrough Device for Use in a Ballistic Environment				
12. PERSONAL AUTHOR(S) Tompkins, R.E.				
13a. TYPE OF REPORT TR	13b. TIME COVERED FROM _____ TO _____	14. DATE OF REPORT (Year, Month, Day)	15. PAGE COUNT	
16. SUPPLEMENTARY NOTATION				
17. COSATI CODES		18. SUBJECT TERMS (Continue on reverse if necessary and identify by block number)		
FIELD	GROUP			SUB-GROUP
19. ABSTRACT (Continue on reverse if necessary and identify by block number) An electrical feedthrough device for use at pressures up to 700 MPa in a ballistic environment has been designed, built, and tested. This unit was designed around existing seal technology and can be installed in cavities machined to accept the Kistler 607C and the PCB 118 pressure transducers.				
20. DISTRIBUTION / AVAILABILITY OF ABSTRACT <input type="checkbox"/> UNCLASSIFIED/UNLIMITED <input checked="" type="checkbox"/> SAME AS RPT. <input type="checkbox"/> DTIC USERS		21. ABSTRACT SECURITY CLASSIFICATION Unclassified		
22a. NAME OF RESPONSIBLE INDIVIDUAL Robert E. Tompkins		22b. TELEPHONE (Include Area Code) (301) 278-6200	22c. OFFICE SYMBOL SLCBR-IB-B	

BLANK

ACKNOWLEDGMENTS

The author wishes to thank Dr. Juhasz, who proposed the conceptual idea for the device, for valuable insight and helpful suggestions throughout the design and testing phase of the electrode. I would also like to thank Mr. Charles D. Bullock for doing the hydrostatic testing in excess of 700 MPa.

BLANK

TABLE OF CONTENTS

	<u>Page</u>
LIST OF FIGURES	vii
I. INTRODUCTION	1
II. DESIGN OF THE ELECTRICAL FEEDTHROUGH	3
III. ASSEMBLY AND INSTALLATION	8
IV. CONCLUSIONS AND FUTURE PLANS	10
REFERENCES	11
APPENDIX A	13
DISTRIBUTION LIST	17

BLANK

LIST OF FIGURES

<u>Figure</u>		<u>Page</u>
1	Photograph Showing the Electrical Feedthrough Both Assembled and Unassembled	2
2	Igniter Body	5
3	Igniter Center Electrode	6
4	Center Electrode Extension	7
5	Igniter Mounting Cavity	9

I. INTRODUCTION

Interior ballistic studies at the BRL encompass a wide range of experiments dealing with the ignition, flamespread, and combustion of propellants. These studies may deal with an examination of process phenomena as in optical, flash x-ray, or interrupted burner studies, the derivation of high pressure propellant burning rates, as in closed bomb studies, or the chemistry of the processes involved in the combustion sequence of propellants. One common concern of each type of study is the reliable delivery of the energy necessary to initiate the process. Generally, whether the sequence is initiated by a hot wire, electric primer, or electric match, an electric feedthrough device is required to conduct the required current/voltage into the experimental fixture. The electric feedthrough can pose nettlesome problems, especially in experiments where gas temperatures can reach 3000 K and pressures approach 700 MPA.

There are many methods for constructing electrical feedthroughs for high pressure vessels. These include multiple variations of the traditional unsupported area design of Bridgman¹ from the 1930's using pipestone cones to act as both sealing agent and as electrical insulator. A not so reliable method is to seal small diameter wires into holes with the use of epoxies, highly compacted ceramic powders, or oils frozen with liquid gases.² A good review of the above methods has been done by Downs and Payne.² A fairly recent approach that has seen good success has been the use of spherical sealing seats in conjunction with ball bearings and thin pieces of plastic.³⁻⁴ As many high pressure experimenters can verify, the actual execution of a successful electrical feedthrough design for a given application frequently involves a number of trials and failures which, especially in the case of high pressure combustion experiments, can lead to significant equipment damage and repair costs.

A wide range of igniter electrode configurations have been explored in the BRL high pressure propellant characterization effort. In fact, the diversity of electrical feedthrough devices in the fixtures has resulted in a myriad of small parts and seals which has become clearly undesirable. To eliminate the potpourri of seal parts the decision was made to design a general purpose electrical feedthrough device for use up to 700 MPa (101,500 psi) in the closed bomb propellant combustion vessels. To simplify use in general range operations, this device has been designed specifically to be installed in the mounting cavity for Kistler 607 or PCB 118 piezoelectric pressure transducers, both of which are in common use at BRL. A picture of the resultant electrical feedthrough is shown in Figure 1.

HOUSING



(Vascomax 350)

**ELECTRICAL
FEEDTHROUGH**



(316 Stainless)

INSULATION



(Shrink Tubing)



(Nylon Washer)

WASHER



NUT



ASSEMBLY



Figure 1. Photograph Showing the Electrical Feedthrough
Both Assembled and Unassembled

II. DESIGN OF THE ELECTRICAL FEEDTHROUGH

The design requirements for the ignition device were as follows:

1. The mechanical aspects of the device are to be designed for pressures of 1000 MPa (145,000 psi).
2. The device must be reusable at 690 MPa.
3. The device must withstand the temperature extremes of up to 3000 K.
4. The device must fit into a Kistler 607C and a PCB 118 pressure transducer hole.
5. The device must be simple enough to be quickly rebuilt by virtually anyone with a minimum of instruction.

The actual design of the igniter was straightforward. The outer body dimensions and pressure sealing technique were determined by design requirement number four, compatibility with two commonly used pressure transducers. See Figures 2, 3, and 4 for drawings of the principle components of the electrical feedthrough. The outer body of the device (Figure 2) is machined out of a precipitation hardened steel, Vascomax 350, and heat treated to a 0.2% yield stress of 2300 MPa. While this is a fairly high yield stress for this material, the decision was made that the fixture body housing this device should fail before the feedthrough. The additional driving force for using this high value of yield stress is to insure that the fixture fails electrically before it fails mechanically. The center electrode (Figure 3) is machined from type 316 stainless steel. This is a work hardening stainless with excellent corrosion resistance. An electrode tip extension (Figure 4) is screwed on the end of the center electrode to prevent the combustion event from continually eroding the center electrode. This allows the user to inexpensively replace the one item that is in intimate contact with the harsh combustion environment.

The weakest area is the threaded section of the igniter body which must contain all of the force that is transmitted to the front face. An analysis of the threads follow.⁵

For the device in question, the pressure acts over a maximum diameter of 6.4 mm. At a pressure as high as 1000 MPa, the total axial force is 32,000 N. The total force that can be restrained may be calculated as follows:

The material that the electrode screws into has a 0.2% Yield Stress of 1100 MPa (160,000 psi). The shear stress is limited to 25% of the yield stress or 275 MPa. The effective diameter of the threads (3/8-24-UNF) is 8.6 mm, with an engaged thread length of 8 mm. The equivalent area resisting shear, including a 60% factor to allow for various stress raising effects, will be:

$$3.1416 \times 8.6 \times 8 \times .60 = 130 \text{ mm}^2$$

The total force able to be contained is:

$$275 \text{ MPa} \times 130 \text{E-6 m}^2 = 36,000 \text{ N}$$

This is above the maximum axial load force, at 1000 MPa (145,000 psi), of 32,000 N so the threads should not fail.

The average contact pressure on the area normal to the axis of the flanks of the threads should also be examined for possible thread seizure. With a mean diameter of 8.6 mm, the thread depth will be about 0.75 mm and the projected area will be 20 mm^2 . Allowing a factor of 75% for mating imperfections and truncating, the net area is 15 mm^2 . Since the engaged length is 8/1.06 pitches (thread length/thread pitch), the total flank area will be $15 \times 8/1.06$ or 113 mm^2 . This gives a mean bearing pressure of about 283 MPa. While this bearing pressure seems a little high, this is taking into account the 50% over-design pressure. If the engaged threads are properly cut and lubricated with a small amount of molybdenum disulfide there should not be any problem with seizure.

If the threads are not going to fail, then the only other failure consideration is extrusion of the center electrode. An analysis of that possibility, by calculating the force necessary to cold extrude the center electrode,⁶ quickly yields the fact that extrusion will not occur until pressures well past 1000 MPa.

Insulating the center electrode from the outer housing is easily accomplished using thin-walled heat-shrink tubing. Other materials may also be used depending on what is available or desirable. This includes: teflon tape, electrical tape, scotch tape, or even paper. For applications involving a vacuum, the use of an epoxy is recommended.

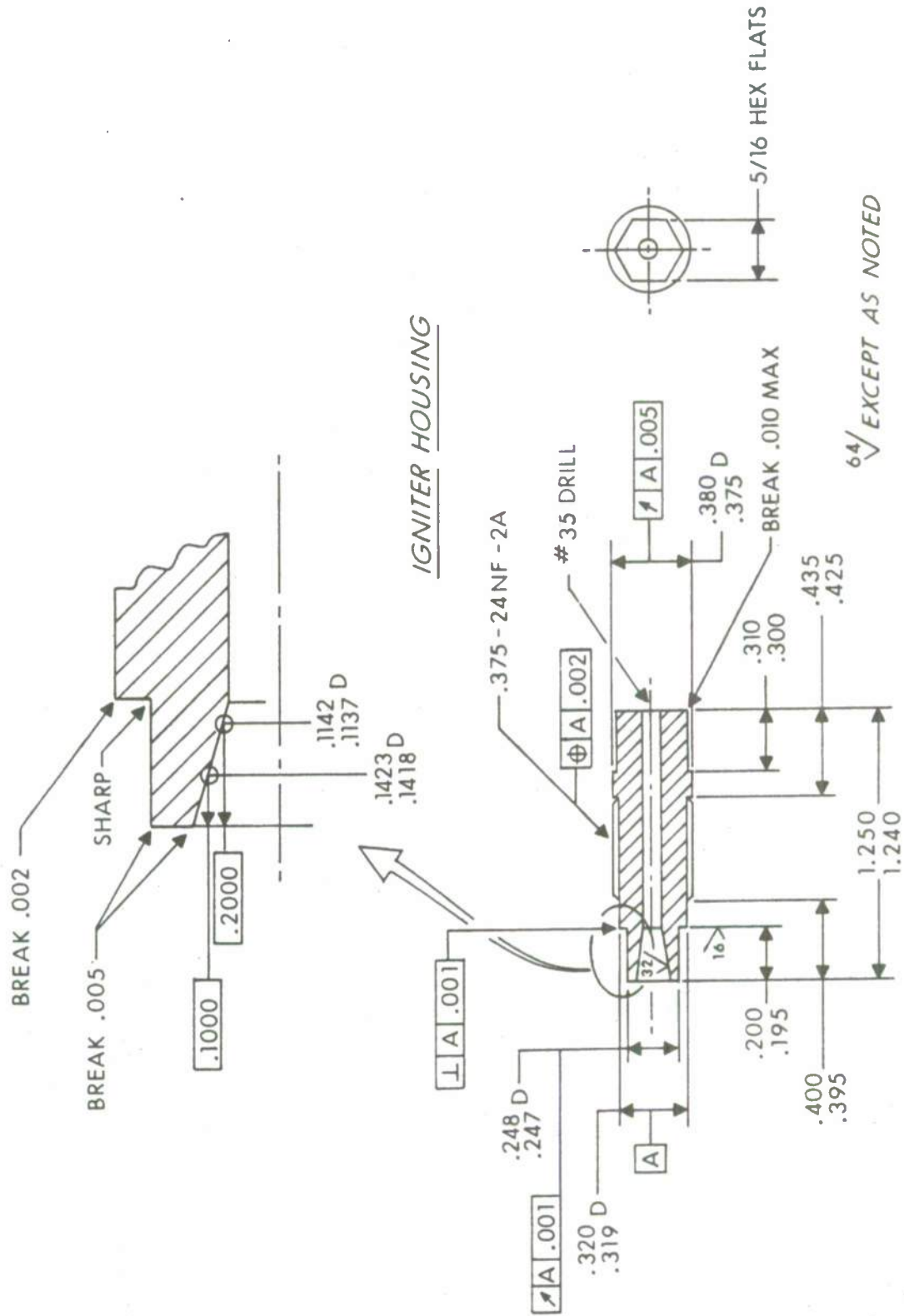
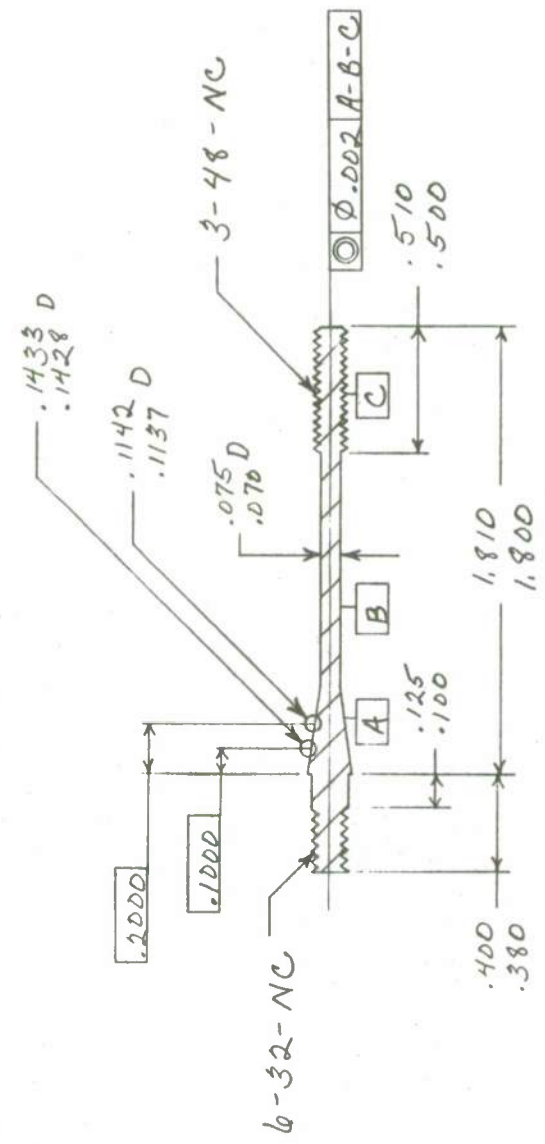

Figure 2. Igniter Body

DATE	SWM	REVISION RECORD	AUTH	DR.	CK.



63 ✓ FOR ALL SURFACES

TOLERANCES (EXCEPT AS NOTED)	SCALE	DRAWN BY
DECIMAL		APPROVED BY
FRACTIONAL		TITLE
ANGULAR		DATE
		DRAWING NUMBER

Figure 3. Igniter Center Electrode

DATE	BY	REVISION RECORD	AUTH. DR.	CHK.

DRILL & TAP
 G-32-NC
 .400-.050 DEEP B.C.

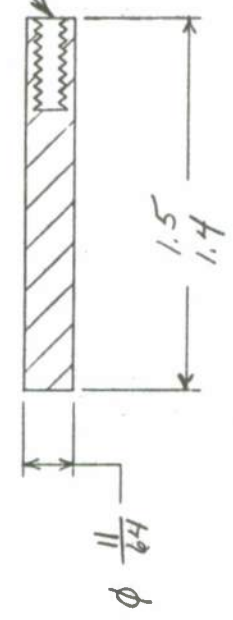

MATL. - DRILL ROD

TOLERANCES (UNLESS OTHERWISE SPECIFIED)	SCALE		DRAWN BY
DECIMAL			APPROVED BY
FRACTIONAL	TITLE		
ANGULAR	DATE		
	DRAWING NUMBER		

Electrode Tip
 28 Apr 67

Figure 4. Center Electrode Extension

III. ASSEMBLY AND INSTALLATION

While assembly of the device is fairly simple, it is not foolproof and care must be taken to insure reliable operation. The insulation must be installed carefully to avoid shorting out the electrical signal. Before applying the insulator, insure that the electrode, the outer body, and the insulation are all clean and free of grit. Apply the insulation to the electrode in such a manner as to end with a uniform thickness of insulation, especially on the tapered portion of the electrode. Now insert the insulated electrode into the body, install the insulating washer, the steel washer, and snug the nut onto the screw threads. At this point it is recommended that the electrode be seated in the outer housing. This may be accomplished by rapping the interior end of the electrode on a hard surface or preferably by squeezing the assembly in a vise by using a 5/16 socket to protect the exterior threads of the electrode.

The device should be checked for continuity between the outer housing and the inner electrode after assembly. Once the user is satisfied that the insulation is integral, the device may be installed in a suitable cavity. Special care should be taken to make sure that there are no foreign particles in the cavity or on the feedthrough. The mounting threads should receive a scant coating of molybdenum disulfide lubricant prior to installation. The feedthrough should be tightened to 15-18 foot-pounds of torque to obtain a leakproof seal. A drawing of the mounting cavity is shown in Figure 5. There are special tools available from Kistler that will facilitate the machining of the mounting cavity. A list of these special tools and the sealing washers which may be purchased from Kistler may be found in Appendix A.

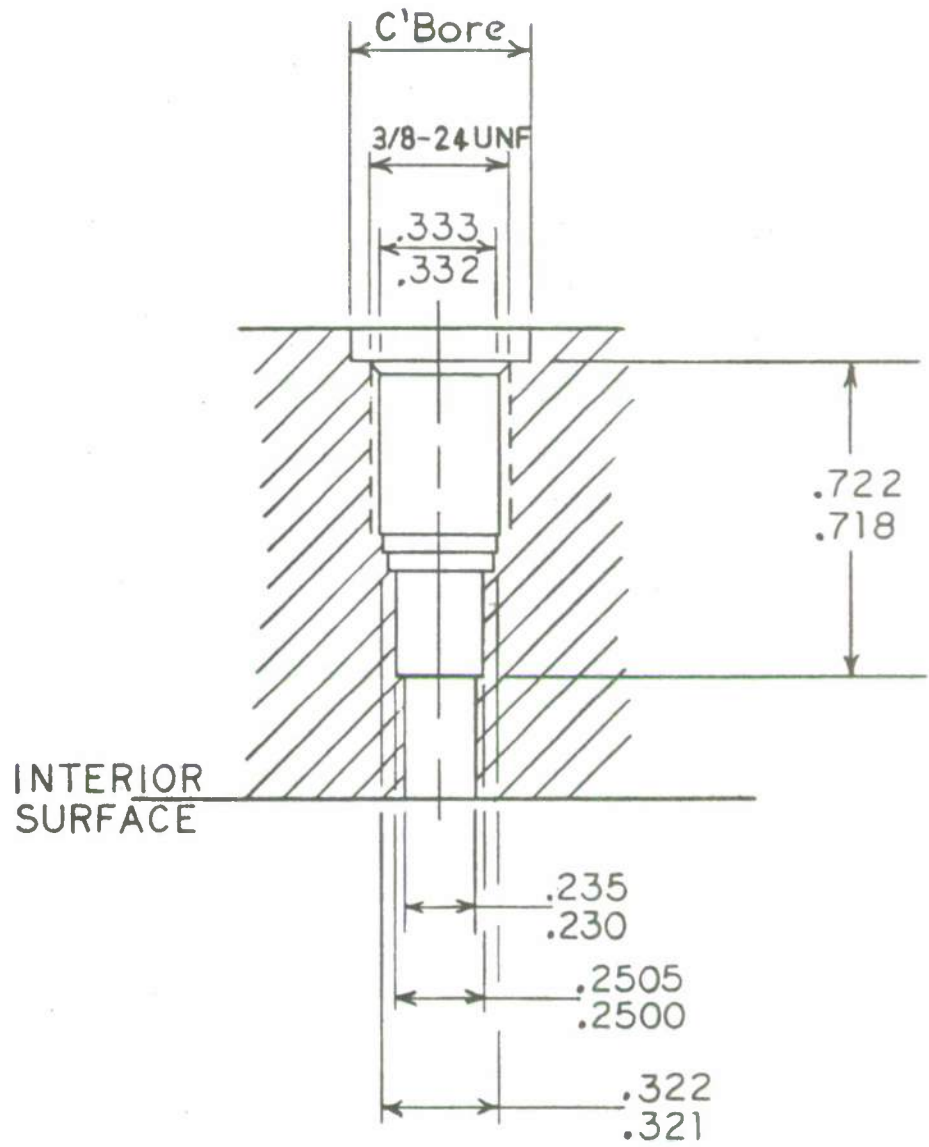

Figure 5. Igniter Mounting Cavity

IV. CONCLUSIONS AND FUTURE PLANS

An electrical feedthrough device has been designed, built and tested at 700 MPa in an environment of burning propellant. There are two parts to be machined and heat treated by trained personnel. Assembly and installation takes a minimum of time, especially for one familiar with installing piezoelectric transducers. This design has been routinely used at pressures of 690 MPa during closed bomb tests at the Ballistic Research Lab for over a year. It is expected that usage will extend to other experimental fixtures as well.

This type of electrical feedthrough device can easily be adapted to other pressure gauge configurations. There are also plans to build some optical or laser diagnostic ports using sapphire to replace the center electrode. In addition, there have been discussions about modifying the basic configuration to do heat flux measurements and bore surface temperature measurements.

REFERENCES

1. Bridgman, P.W., The Physics Of High Pressure, Bell And Sons, London, 1949.
2. Downs, J.L. and Payne R.T., "A Review of Electrical Feedthrough Techniques for High Pressure Gas Systems," Rev. Sci. Instrum., Vol. 40, No. 10, p. 1278, October 1969.
3. Benzing, W.M., Jamieson, J.C., and Halleck, P.M., "Spherical Electrical Feedthroughs for High Pressure Vessels," Rev. Sci. Instrum., Vol. 43, No. 7, p. 1052, July 1972.
4. Vassillou, J.K. and Jamieson, J.C., "Improved Spherical Electrical Feedthroughs For High Pressure, Nonambient Temperature Vessels," Rev. Sci. Instrum., Vol. 51, No. 11, p. 1577, November 1980.
5. Manning, W.R.D. and Labrow, S., High Pressure Engineering, Godwin LTD., London, 1976.
6. John A. Schey, Introduction To Manufacturing Processes, McGraw-Hill, Inc., New York, 1977.

BLANK

APPENDIX A
AVAILABLE SEALS AND TOOLING FOR MOUNTING
THE ELECTRICAL FEEDTHROUGH

BLANK

This Appendix is included to list seals and tools that are available from the Kistler Instrument Corporation. The use and application of all of the items listed are described in the instruction manual for the 207C and the 607C high pressure transducers which is also available from the company.

Table 1A

Kistler Part Number	Description of Part
6000E42	Copper Seal
600A10	Stainless Steel Seal
600R1	Flat End Chucking Reamer
600R6	Flat End Chucking Reamer
600R8	Piloted Step-diameter Reamer

BLANK

DISTRIBUTION LIST

<u>No. of</u> <u>Copies</u>	<u>Organization</u>	<u>No. of</u> <u>Copies</u>	<u>Organization</u>
12	Commander Defense Technical Info Center ATTN: DTIC-DDA Cameron Station Alexandria, VA 22304-6145	1	Commander US Army Materiel Command ATTN: AMCPM-GCM-WF 5001 Eisenhower Avenue Alexandria, VA 22333
1	Commander USA Concepts Analysis Agency ATTN: D. Hardison 8120 Woodmont Avenue Bethesda, MD 20014	1	Commander US Army Materiel Command ATTN: AMCDRA-ST 5001 Eisenhower Avenue Alexandria, VA 22333-0001
1	HQDA/DAMA-ZA Washington, DC 20310	5	Project Manager Cannon Artillery Weapons System, ARDEC, AMCCOM ATTN: AMCPM-CW, F. Menke AMCPM-CWW AMCPM-CWS, M. Fisette AMCPM-CWA, R. DeKleine H. Hassmann Picatinny Arsenal, NJ 07806-5000
1	HQDA, DAMA-CSM, E. Lippi Washington, DC 20310		
1	HQDA, DAMA-ART-M Washington, DC 20310		
1	HQDA/SARDA Washington, DC 20310		
1	Commander US Army War College ATTN: Library-FF229 Carlisle Barracks, PA 17013	2	Project Manager Munitions Production Base Modernization and Expansion ATTN: AMCPM-PBM, A. Siklosi AMCPM-PBM-E, L. Laibson Picatinny Arsenal, NJ 07806-5000
1	Director US Army BMD Advanced Technology Center PO Box 1500 Huntsville, AL 35807		
1	Chairman DOD Explosives Safety Board Room 856-C Hoffman Bldg 1 2461 Eisenhower Avenue Alexandria, VA 22331	3	Project Manager Tank Main Armament System ATTN: AMCPM-TMA, K. Russell AMCPM-TMA-105 AMCPM-TMA-120 Picatinny Arsenal, NJ 07806-5000

DISTRIBUTION LIST

<u>No. of</u> <u>Copies</u>	<u>Organization</u>	<u>No. of</u> <u>Copies</u>	<u>Organization</u>
1	Commander US Army Watervliet Arsenal ATTN: SARWV-RD, R. Thierry Watervliet, NY 12189	4	Commander US AMCCOM ATTN: SMCAR-ESP-L AMSMC-IRC, G. Cowan SMCAR-ESM(R), W. Fortune R. Zastrow Rock Island, IL 61299-7300
22	Commander Armament RD&E Center US Army AMCCOM ATTN: SMCAR-IMI-I SMCAR-TDC SMCAR-AE SMCAR-AEE-B, A. Beardell D. Downs S. Einstein S. Westley S. Bernstein N. Baron A. Bracuti J. Rutkowski L. Stiefel B. Brodman SMCAR-CCD, D. Spring SMCAR-AEE, J. Lannon SMCAR-AES, S. Kaplowitz SMCAR-CCS SMCAR-CCH-T, L. Rosendorf SMCAR-CCH-V, E. Fennell SMCAR-FSA-T, M. Salsbury Picatinny Arsenal, NJ 07806-5000	1	Director Benet Weapons Laboratory Armament R&D Center US Army AMCCOM ATTN: SMCAR-CCB-TL Watervliet, NY 12189
		1	Commander US Army Aviation Research and Development Command ATTN: AMSAV-E 4300 Goodfellow Blvd St. Louis, MO 63120
		1	Commander US Army TSARCOM 4300 Goodfellow Blvd St. Louis, MO 63120
		1	Director US Army Air Mobility Research and Development Laboratory Ames Research Center Moffett Field, CA 94035
		1	Commander US Army Communications Electronics Command ATTN: AMSEL-ED Fort Monmouth, NJ 07703
		1	Commander ERADCOM Technical Library ATTN: STET-L Fort Monmouth, NJ 07703-5301

DISTRIBUTION LIST

<u>No. of</u> <u>Copies</u>	<u>Organization</u>	<u>No. of</u> <u>Copies</u>	<u>Organization</u>
1	Commander US Army Harry Diamond Lab ATTN: DELHD-TA-L 2800 Powder Mill Road Adelphi, MD 20783	1	Project Manager Fighting Vehicle Systems ATTN: AMCPM-FVS Warren, MI 48090
1	Commander US Army Missile Command Rsch, Dev, & Engr Ctr ATTN: AMSMI-RD Redstone Arsenal, AL 35898	1	President USA Armor & Engineer Board ATTN: ATZK-AD-S Ft. Knox, KY 40121
1	Director US Army Missile & Space Intelligence Center ATTN: AIAMS-YDL Redstone Arsenal, AL 35898-5500	1	Project Manager M-60 Tank Development ATTN: AMCPM-M60TD Warren, MI 48090
1	Commandant US Army Aviation School ATTN: Aviation Agency Fort Rucker, AL 36360	1	Director US Army TRADOC Systems Analysis Activity ATTN: ATAA-SL White Sands Missile Range, NM 88002
1	Commander US Army Tank Automotive Cmd ATTN: AMSTA-TSL Warren, MI 48397-5000	1	Commander USA Training & Doctrine Cmd ATTN: ATCD-MA/MAJ Williams Ft. Monroe, VA 23651
1	Commander US Army Tank Automotive Cmd ATTN: AMSTA-CG Warren, MI 48090	1	Commander USA Materials Technology Lab Dyna East Corporation ATTN: Christine P. Brandt, Document Control 3132 Market Street Philadelphia, PA 19104-2855
1	Project Manager Improved TOW Vehicle US Army Tank Automotive Cmd ATTN: AMCPM-ITV Warren, MI 48090	1	Commander US Army Research Office ATTN: Tech Library PO Box 12211 Research Triangle Park, NC 27709-2211
1	Program Manager M1 Abrams Tank System ATTN: AMCPM-GMC-SA, T. Dean Warren, MI 48090		

DISTRIBUTION LIST

<u>No. of</u> <u>Copies</u>	<u>Organization</u>	<u>No. of</u> <u>Copies</u>	<u>Organization</u>
1	Commander US Army Belvoir R&D Ctr ATTN: STRBE-WC Tech Library (Vault) Bldg 315 Ft. Belvoir, VA 22060-5606	1	Commandant US Army Field Artillery Center & School ATTN: ATSF-CO-MW, B. Willis Ft. Sill, OK 73503
1	Commander US Army Logistics Ctr Defense Logistics Studies Ft. Lee, VA 23801	1	Commander US Army Development and Employment Agency ATTN: MODE-TED-SAB Ft. Lewis, WA 98433
1	Commandant US Army Infantry School ATTN: ATSH-CD-CSO-OR Ft. Benning, GA 31905	1	Office of Naval Research ATTN: Code 473, R.S. Miller 800 N. Quincy Street Arlington, VA 22217
1	President US Army Artillery Board Ft. Sill, OK 73503	2	Commander Naval Sea Systems Command ATTN: SEA 62R SEA 64 Washington, DC 20362-5101
1	Commandant US Army Command and General Staff College Ft. Leavenworth, KS 66027-5080	1	Commander Naval Air Systems Command ATTN: AIR-954-Tech Lib Washington, DC 20360
1	Commandant USA Special Warfare School ATTN: Rev & Tng Lit Div Ft. Bragg, NC 28307	1	Assistant Secretary of the Navy (R, E, and S) ATTN: R. Reichenbach Room 5E787 Pentagon Bldg Washington, DC 20350
1	Commander Radford Army Ammo Plant ATTN: SMCRA-QA/HI LIB Radford, VA 24141	1	Naval Research Lab Tech Library Washington, DC 20375
1	Commander US Army Foreign Science & Technology Center ATTN: AMXST-MC-3 220 Seventh Street, NE Charlottesville, VA 22901	2	Commander US Naval Surface Weapons Ctr ATTN: J.P. Consaga C. Gotzmer Silver Spring, MD 20902-5000

DISTRIBUTION LIST

<u>No. of</u> <u>Copies</u>	<u>Organization</u>	<u>No. of</u> <u>Copies</u>	<u>Organization</u>
3	Naval Surface Weapons Center ATTN: S. Jacobs/R10 Code 730 K. Kim/Code R-13 R. Bernecker/Code R-13 Silver Spring, MD 20902-5000	4	Commander Naval Ordnance Station ATTN: J. Birkett D. Brooks W. Vienne Tech Library Indian Head, MD 20640
5	Commander Naval Surface Weapons Center ATTN: Code G33, J.L. East W. Burrell J. Johndrow Code G23, D. McClure Code DX-21 Tech Lib Dahlgren, VA 22448-5000	1	HQ AFSC/SDOA Andrews AFB, MD 20334
2	Commander Naval Underwater Systems Ctr Energy Conversion Dept ATTN: Code 5B331, R.S. Lazar Tech Library Newport, RI 02840	1	AFRPL/DY, Stop 24 ATTN: J.N. Levine/DYCR Edwards AFB, CA 93523-5000
3	Commander Naval Weapons Center ATTN: Code 388, R.L. Derr C.F. Price T. Boggs Info Science Div China Lake, CA 93555-6001	1	AFRPL/TSTL (Tech Library) Stop 24 Edwards AFB, CA 93523-5000
1	Superintendent Naval Postgraduate School Dept of Mechanical Engr Code 1424 Library Monterey, CA 93943	1	AFRPL/MKPB, Stop 24 ATTN: B. Goshgarian Edwards AFB, CA 93523-5000
1	Program Manager AFOSR Directorate of Aerospace Sciences ATTN: L.H. Caveny Bolling AFB, DC 20332	1	AFFTC ATTN: SSD-Tech Lib Edwards AFB, CA 93523
		1	AFATL/DLYV ATTN: George C. Crews Eglin AFB, FL 32542-5000
		1	AFATL/DLJE Eglin AFB, FL 32542-5000
		1	Air Force Armament Lab AFATL/DLODL Eglin AFB, FL 32542-5000
		1	AFWL/SUL Kirtland AFB, NM 87117
		1	Commandant USAFAS ATTN: STSF-TSM-CN Ft. Sill, OK 73503-5600

DISTRIBUTION LIST

<u>No. of Copies</u>	<u>Organization</u>	<u>No. of Copies</u>	<u>Organization</u>
10	Central Intelligence Agency Office of Central Reference Dissemination Branch Room GE-47 HQS Washington, DC 20502	1	IITRI ATTN: M.J. Klein 10W. 35th Street Chicago, Il 60616
1	Central Intelligence Agency ATTN: Joseph E. Backofen HQ Room 5F22 Washington, DC 20505	1	Hercules Powder Co Allegany Ballistics Lab ATTN: R.B. Miller PO Box 210 Cumberland, MD 21501
1	General Applied Sciences Lab ATTN: J. Erdos Merrick & Stewart Avenues Westbury, NY 11590	1	Hercules, Inc Bacchus Works ATTN: K.P. McCarty PO Box 98 Magna, UT 84044
1	Aerodyne Research, Inc. Bedford Research Park ATTN: V. Yousefian Bedford, MA 01730	2	Director Lawrence Livermore National Laboratory ATTN: M.S. L-355, A. Buckingham PO Box 808 Livermore, CA 94550
1	Aeroproject Solid Propulsion Co ATTN: P. Micheli Sacramento, CA 95813	1	Lawrence Livermore National Laboratory ATTN: M.S. L-355 M. Finger PO Box 808 Livermore, CA 94550
1	Atlantic Research Corporation ATTN: M.K. King 5390 Cheorokee Avenue Alexandria, VA 22314	1	Olin Corporation Badger Army Ammunition Plant ATTN: R.J. Thiede Baraboo, WI 53913
1	AVCO Everett Rsch Lab ATTN: D. Stickler 2385 Revere Beach Parkway Everett, MA 02149	1	Olin Corp/Smokeless Powder Operations R&D Library ATTN: V. McDonald PO Box 222 St. Marks, FL 32355
1	Calspan Corporation ATTN: Tech Library PO Box 400 Buffalo, NY 14225		
1	General Electric Company Armament Systems Dept ATTN: M.J. Bulman, R-1311 Lakeside Avenue Burlington, VT 05401		

DISTRIBUTION LIST

<u>No. of</u> <u>Copies</u>	<u>Organization</u>	<u>No. of</u> <u>Copies</u>	<u>Organization</u>
1	Paul Gough Associates, Inc. ATTN: P.S. Gough PO Box 1614 1048 South St. Portsmouth, NH 03801	1	Thiokol Corporation Wasatch Division ATTN: Tech Library PO Box 524 Brigham City, UT 84302
1	Physics International Company ATTN: Library H. Wayne Wampler 2700 Merced Street San Leandro, CA 94577	2	Thiokol Corporation Elkton Division ATTN: R. Biddle Tech Library PO Box 241 Elkton, MD 21921
2	Rockwell International Rocketdyne Division ATTN: BA08 J.E. Flanagan J. Gray 6633 Canoga Avenue Canoga Park, CA 91304	1	Universal Propulsion Company ATTN: H.J. McSpadden Black Canyon Stage 1 Box 1140 Phoenix, AZ 85029
1	Princeton Combustion Rsch Lab ATTN: M. Summerfield 475 US Highway One Monmouth Junction, NJ 08852	2	United Technologies Chemical Systems Division ATTN: R. Brown Tech Library PO Box 358 Sunnyvale, CA 94086
1	Science Applications, Inc. ATTN: R.B. Edelman 23146 Cumorah Crest Woodland Hills, CA 91364	1	Veritay Technology, Inc. 4845 Millersport Hwy PO Box 305 East Amherst, NY 14051-0305
3	Thiokol Corporation Huntsville Division ATTN: D. Flanagan R. Glick Tech Library Huntsville, AL 35807	1	Battelle Memorial Institute ATTN: Tech Library 505 King Avenue Columbus, OH 43201
1	Scientific Rsch Assoc, Inc ATTN: H. McDonald PO Box 498 Glastonbury, CT 06033	1	Brigham Young University Dept of Chemical Engr ATTN: M. Beckstead Provo, UT 84601

DISTRIBUTION LIST

<u>No. of</u> <u>Copies</u>	<u>Organization</u>	<u>No. of</u> <u>Copies</u>	<u>Organization</u>
1	California Institute of Tech 204 Karman Lab Main Stop 301-46 ATTN: F.E.C. Culick 1201 E. California Street Pasadena, CA 91109	1	Institute of Gas Technology ATTN: D. Gidaspow 3424 S. State Street Chicago, IL 60616
1	California Institute of Tech Jet Propulsion Laboratory ATTN: L.D. Strand 4800 Oak Grove Drive Pasadena, CA 91103	1	Johns Hopkins University Applied Physics Laboratory Chemical Propulsion Information Agency ATTN: T. Christian Johns Hopkins Road Laurel, MD 20707
1	Professor Herman Krier Dept of Mech/Indust Engr University of Illinois 144 MEB; 1206 N. Green St Urbana, IL 61801	1	Massachusetts Institute of Technology Dept of Mechanical Engr ATTN: T. Toong 77 Massachusetts Avenue Cambridge, MA 02139
1	University of Minnesota Dept of Mechanical Engr ATTN: E. Fletcher Minneapolis, MN 55455	1	Pennsylvania State Univ. Dept of Mechanical Engr ATTN: K. Kuo University Park, PA 16802
1	Washington State University Dept of Mechanical Engr ATTN: C.T. Crowe Pullman, WA 99163	1	University of Michigan Gas Dynamics Lab Aerospace Engr Bldg ATTN: Dr. G.M. Faeth Ann Harbor, MI 48109-2140
1	Case Western Reserve U. Division of Aerospace Sciences ATTN: J. Tien Cleveland, OH 44135	1	Purdue University School of Mechanical Engr ATTN: J.R. Osborn TSPC Chaffee Hall West Lafayette, IN 47906
3	Georgia Institute of Tech School of Aerospace Engr ATTN: B.T. Zinn E. Price W.C. Strahle Atlanta, GA 30332	1	SRI International Propulsion Sciences Division ATTN: Tech Library 333 Ravenswood Avenue Menlo Park, CA 94025

DISTRIBUTION LIST

<u>No. of</u> <u>Copies</u>	<u>Organization</u>	<u>No. of</u> <u>Copies</u>	<u>Organization</u>
1	Rensselaer Polytechnic Inst. Department of Mathematics Troy, NY 12181		Cdr, CRDEC, AMCCOM ATTN: SMCCR-RSP-A SMCCR-MU SMCCR-SPS-IL
1	Director Los Alamos National Lab ATTN: M. Division, B. Craig T-3 MS B216 Los Alamos, NM 87545		Cdr, USACSTA ATTN: S. Walton G. Rice D. Lacey C. Herud
1	Stevens Inst. of Tech Davidson Laboratory ATTN: R. McAlevy, III Castle Point Station Hoboken, NJ 07030		Dir, HEL ATTN: J. Weisz
1	Rutgers University Dept of Mechanical and Aerospace Engr ATTN: S. Temkin University Heights Campus New Brunswick, NJ 08903		
1	U. of Southern California Mechanical Engr Dept ATTN: OHE200, M. Gerstein Los Angeles, CA 90007		
2	University of Utah Dept of Chemical Engineering ATTN: A. Baer G. Flandro Salt Lake City, UT 84112		

Aberdeen Proving Ground

Dir, USAMSAA
ATTN: AMXSY-D
AMXSY-MP, H. Cohen

Cdr, USATECOM
ATTN: AMSTE-TO-F

BLANK



DEPARTMENT OF THE ARMY

USA LABCOM/BRL
APG, MD 21005-5066
OFFICIAL BUSINESS
PENALTY FOR PRIVATE USE. \$300

FIRST CLASS

DA Label 18-1, Sep 83
Edition of Oct 74 will be used until exhausted

Chairman
DOD Explosives Safety Board
Room 856-C
Hoffman Bldg. 1
2461 Eisenhower Avenue
Alexandria, VA 22331