

DTIC FILE COPY

TECH. MEMO  
78(F) 457

TECH. MEMO  
78(F) 457

① *James 2*



*Supersedes James 1,  
DRIC-BR-84221*

AD-A191 992

ROYAL AIRCRAFT ESTABLISHMENT

EQUIPMENT TEST METHODS FOR EXTERNALLY PRODUCED  
ELECTROMAGNETIC TRANSIENTS

by

R. A. Hobbs

July 1987

DTIC  
ELECTE  
MAR 02 1988  
S D  
E

Procurement Executive, Ministry of Defence  
Farnborough, Hants

Best Available Copy

88 2 26 071

ROYAL AIRCRAFT ESTABLISHMENT

RAE TECHNICAL MEMORANDUM FS(F) 457

ISSUE 2

Received for Printing; 25 June 1987

EQUIPMENT TEST METHODS FOR  
EXTERNALLY PRODUCED ELECTROMAGNETIC TRANSIENTS

by

R.A.Hobbs

*This Memorandum assesses*

SUMMARY

This Memorandum is the result of the work at the Royal Aircraft Establishment in assessing the effect of electromagnetic pulse and lightning strike produced transients to aircraft systems. It details suitable tests for the simulation of these effects and should be used to form the basis of any future aircraft project transient specifications with suitable tailoring to meet specific requirements with the formal approval of the Project Director.

*(Great Britain)*

Copyright

©  
Controller HMSO London  
1987

This Memorandum expresses the opinions of the author and does not necessarily represent the official view of the Royal Aircraft Establishment.

( i )

## CONTENTS

Section/paragraph	Subject	Page No.
1.	INTRODUCTION	1
1.1	NEMP environment	1
1.2	Transient effects produced by lightning strikes	
1.2.1	High frequency transients	2
1.2.2	Resistive/diffusion flux coupling	2
1.2.3	Aperture flux coupling	2
1.2.4	Ground voltage spikes	2
1.3	Validity of testing at equipment level	2
2.	EQUIPMENT LAYOUT FOR NEMP AND LEMP TEST METHOD	4
2.1	Ground plane	4
2.2	Line impedance stabilisation networks	4
2.3	Equipment layout and lead lengths	5
2.4	Bonding of equipment under test	5
2.5	EUT interface loads and test jigs	6
2.6	Excitation of equipment under test	6
2.7	Current probes	6
2.7.1	Injection probes	6
2.7.2	Monitoring probes	7
2.8	Oscilloscope and probes	7
3.	SUSCEPTIBILITY CRITERIA	8
4.	TRANSIENT GENERATORS	8
4.1	NEMP and HF lightning induced transients	8
4.2	Ground voltage transient generators	8
5.	HEALTH AND SAFETY AT WORK	9
6.	TEST METHODS	9
6.1	EMP and lightning HF transients effects	9
6.1.1	Selection of transient injection frequencies	10
6.1.2	Transient injection testing	10
6.1.3	Test limits for damped sinusoidal testing	11
6.2	Lightning ground voltage injection	12
6.2.1	Transient testing	13
6.2.2	Test limits for ground voltage injection	13



Accession For	
NCIS GRA&I	<input checked="" type="checkbox"/>
DTIC TAB	<input type="checkbox"/>
Unannounced	<input type="checkbox"/>
Justification	
By _____	
Distribution/	
Availability Codes	
Dist	Avail and/or Special
A-1	

7.	ACCEPTANCE TESTING OF EQUIPMENT POST TRIAL	15
8.	CONCLUSION	15
9.	ACKNOWLEDGEMENT	15
TABLE 1	Test frequencies	16
REFERENCES		17
INDEX TO ILLUSTRATIONS		18
ILLUSTRATIONS	Figures 1-13	

## **1. INTRODUCTION**

This issue of RAE Technical Memorandum FS(F) 457 replaces the original 1982 version (Ref 1) which should no longer be used. Since the publication of that version there have been considerable improvements to the test methods for the effects of exo-atmospheric nuclear burst (NEMP) and the similar transients produced as a result of lightning strike (LEMP). This Memorandum covers the testing of avionic systems that are to be installed in aircraft and similar vehicles, including those of hybrid metallic/composite construction.

### **1.1 NEMP Environment**

The electromagnetic pulses produced by an endo or exo-atmospheric burst have been well accepted in terms of the definition of amplitude, rise and fall times, polarization and impedance. They are defined in QStag 244 as 'The NATO Standard EMP Pulses'. When an aircraft is subjected to a NEMP there are large currents induced in the skin and these will excite resonances in the aircraft structure and wiring looms. The aircraft can be thought of as a 'tuned receiver' which couples strongly in the HF band but only weakly at other frequencies. Hence for aircraft the exoatmospheric EMP is more severe than the endoatmospheric EMP. The current flow in the cable looms will be of a damped sinusoidal nature. Since the aircraft size and loom lengths/impedances are mainly resonant in the frequency range 2 to 30 MHz and the main energy content of the EMP extends up to this frequency band, the test method described simulates these currents.

### **1.2 Transient Effects produced by lightning strikes**

A detailed explanation of the three types of lightning induced transient that can affect aircraft avionic equipment together with a review of test methods used by some lightning experts and the rationale for the tests proposed in this document will be given in an RAE Technical Memorandum (Ref 2), however the three types of transient are briefly described below. Design certification and testing requirements for Group I (direct) and Group II (indirect) effects of lightning which this Memorandum does not address will be found in RAE Technical Memorandum FS(F)632 (Ref 3) which will require equipment tests to be made in accordance with this document.

The tests described apply to items of avionics such as engine control systems etc, but not to the high voltage insulation testing that is performed on items such as the Pitot tube heater supply or to aircraft antennas.

### **1.2.1 High frequency transients**

The energy contained in the rapid rate of change of E and H fields at the instant of lightning current attachment to the aircraft will excite electrical resonances in the structure and wiring looms that will respond in the same way as for NEMP described above. As such, the testing for this effect is similar to NEMP.

### **1.2.2 Resistive/diffusion flux coupling**

A cable voltage will be produced which is approximately proportional to the lightning current, due to resistive coupling (for example, the voltage gradient on the inside of an aircraft skin), or to inductive coupling where the magnetic flux has diffused through a high resistivity skin (such as carbon-fibre composite) and in doing so has effectively undergone an integrating process.

### **1.2.3 Aperture Flux Coupling**

A cable voltage will be produced which is proportional to the derivative (slope) of the lightning current, due to direct (aperture flux) magnetic coupling. The voltage will then be proportional to the maximum rate of rise of the lightning current, taken to be 100 kA/us for a severe stroke.

### **1.2.4 Ground Voltage Spikes**

The resistive/diffusion and aperture flux coupling described above will give rise to large current flow in cables and voltage stresses to filter components etc where equipments are in different parts of the aircraft but connected by wiring looms. These effects are simulated by tests described in this Memorandum; the resistive/diffusion coupling by the 1/150us waveform test and aperture flux coupling by the 0.05/2us waveform test.

#### **Note:**

For an equipment operating within an airframe of metallic construction the effects of aperture flux coupling and resistive diffusion flux coupling may be of less significance compared with the high frequency transients. This may not be the case for equipments that are to be installed in aircraft where large areas, such as wings, are of composite construction.

### **1.3 Validity of testing at equipment level**

As with EMC test methods it must be realised that the test house environment and equipment layout are inevitably not as found in an aircraft or any other vehicle's actual installation. The test methods for equipment level testing are devised such that as realistic an environment as possible is created. Divergence from the actual installation will necessitate simulation of loads or cable types and thus there will exist the possibility of introducing non-representative failures/upsets. These aspects should be considered and if

appropriate discussed in the trial report at the conclusion of testing. Experience gained in the development of EMC test methods shows that good correlation is normally obtained between failures found by current injection test methods and those obtained as a function of the on-board environment.

## 2. EQUIPMENT LAYOUT FOR NEMP AND LEMP TEST METHOD

The equipment layout for this test method shall be the same as is specified in RAE Technical Memorandum FS(F) 510 (Ref 4), Recommended Test Specification For The Electromagnetic Compatibility of Aircraft Equipment, section 6. This is defined such that the equipment under test is operated in as representative manner as possible and that repeatability between test houses for the testing may be obtained.

### 2.1 Ground Plane

In order to provide a reference plane, the equipment under test (EUT) shall normally be mounted on a solid-plate metallic ground plane having a minimum thickness of 0.25 mm for copper, 0.5 mm for aluminium (non-preferred because of oxidisation) and 0.63 mm for brass, with a minimum area of 2.25 m<sup>2</sup> and minimum side of 0.7 m. The ground plane shall be bonded to the screened room walls, solid sheet bonds being preferred, the bonds being not more than 0.9 m apart. The dc resistance between the ground plane and the walls shall not exceed 2.5 milliohms.

For large equipment mounted in a metal rack or cabinet, the metal rack or cabinet shall be considered a part of the ground plane for testing purposes and shall be bonded to the ground plane by the normal rack or cabinet bonding arrangements.

### 2.2 Line Impedance Stabilising Networks (LISN)

In order to eliminate possible differences in power supply impedance at the different EMC Test Houses, and to provide a defined impedance that is based on typical aircraft bus-bar impedances, a LISN shall be included in all power supply leads to the EUT.

The circuit diagram of the LISNs shall be as shown in Figure 1, further design details are given in RAE Technical Memorandum FS(F) 613 (Ref 5).

The characteristics for the LISN shall be as shown in Figure 2 when loaded with a 50 ohm termination at the measuring set terminal and with the supply or load terminal shorted to the case.

The measuring set terminal shall be terminated by a 50 ohm low-reactance load.

A 10 uF feedthrough capacitor shall be connected on the supply side of the LISN, being bonded to ground.

When used on dc power supplies an additional 30,000 uF capacitor shall be connected between positive and negative in the power supply side of the LISN to improve its low frequency performance. Figure 3 shows protection circuitry which may be necessary to reduce switch-on surges. For safety reasons a bleed resistor (1000 ohms, 1 watt) should be connected across the capacitor.



### 2.3 Equipment layout and lead lengths

Figure 4 shows a typical EUT set-up on a ground plane. A photograph or detailed sketch of the test layout shall be included in the Test Report.

The EUT's power leads and interconnecting cableforms shall whenever possible be of the length, type and layout representative of the aircraft, an installation as similar as possible to that of aircraft should be used. Interconnecting cables shall be supported above the ground plane on 50 mm insulated stand-offs (e.g. Styrofoam). The purpose of this is to simulate the ground loop area of a typical installation where wiring runs cannot always be clamped directly to the vehicle structure over the whole of the cable length.

When the aircraft cableform length is not known, control and signal cable lengths shall be  $2m \pm 0.1m$ . Primary power lines shall always be  $1m \pm 0.1m$ .

When the length of an interconnecting cableform is greater than 2m, the leads must be deployed in a defined manner. The cableform shall be arranged as in Figure 4 with the excess length zig-zagged at the back of the test bench on 50 mm supports. This method is preferred to that of coiling the cable as coiling could increase the cable inductance by as much as ten times for a very long cableform. Some installations require very long cable runs and these cannot be accommodated on the test bench; therefore the maximum length of the interconnecting cableform for these tests shall not exceed 15m. Duplication of an actual installation cableform shall be considered the ideal representation. The lengths of the cableforms must be recorded in the equipment test report.

### 2.4 Bonding of Equipment Under Test

The provisions included in the design of the EUT and specified in the installation instruction shall be used:

- (a) to bond the EUT items together, such as equipment case and mount, and/or
- (b) to bond the EUT to the ground plane.

When used, bonding jumpers and routing shall be as close as possible to those specified for the installation including the method of connection and type of bonding lead.

Equipments intended to be grounded through a third wire should be grounded via that method unless a special installation requires otherwise. When this method is used the EUT shall be placed on an insulating mat.

When EUTs are secured to mounting bases having shock or vibration isolators, bonding straps when furnished with mounting bases, shall be connected to the ground plane. If bonding straps are not specified none shall be fitted.

Portable equipment shall not be bonded to the ground plane during testing unless this is required by the installation specification. Portable equipment that is grounded through the power cable shall not be bonded to the ground plane but shall be mounted on insulating material 50 mm above the ground plane.

When an external terminal lug, stud or connector pin is available for a ground connection on the EUT, it shall be used if normal installation so indicates. When the installation is unknown, the ground terminal or pin shall not be used.

## **2.5 EUT Interface Loads and Test Jigs**

Ideally the transient test should be performed on a complete system or sub-system.

EUTs interfacing with other units, which for practical reasons are not part of the EUT, shall be suitably loaded. The loads may be electrical, electronic, and/or mechanical, as applicable. Electrical/electronic loads should simulate the impedance of the actual load as far as is practical. Care should be taken to ensure that any active loads do not contribute to the susceptibility of the EUT. This may be achieved by filtering the load inputs or outputs.

## **2.6 Excitation of Equipment Under Test**

In addition to the requirements of 2.5 above the following consideration shall be made.

An EMC/EMP Test Plan shall be produced by the manufacturer which defines the mode(s) of operation of the equipment to be used for the tests and the various criteria for performance verification. The test plan shall define the standard of the equipment under test together with details of the interface to support equipment if appropriate.

When practically possible the EUT shall be exercised by the same means as in the actual installation. For example, if a solenoid or a relay is switched by a thyristor or similar semiconductor device do not use a mechanical switch to operate the solenoid or relay. Voltage and/or current regulators which function intermittently shall be exercised during the test, as described in the EMC Test Plan, to simulate real life conditions.

## **2.7 Current Probes**

### **2.7.1 Injection Probes**

The injection probe to be used for the injection of the damped sinusoidal test waveform shall be as described in RAE Technical Memorandum FS(F) 588 (Ref 6), in which design details and performance requirements are specified.

### 2.7.2 Monitoring Probes

The current probes to be used for the measurement of the induced transient must be capable of accurately recording the transient without saturation either by the primary current flow in the loom under test or when combined with the level of injected transient. The transfer characteristic of the probe from the lower -3dB point to the upper -3dB point over the frequency range 0.1 to 50 MHz shall have a uniform flat characteristic such that the correct waveshape is recorded. The probe winding should be electrostatically shielded and the connecting instrumentation cables shall be double screened or 'superscreened', or similar in order to prevent signal breakthrough.

### 2.8 Oscilloscope and Probes

The oscilloscope shall be such that it records the levels and waveforms of both fast and slow transients as required by the test limits. The use of a fast digitising oscilloscope or similar instrument is recommended.

The oscilloscope shall have a 3dB bandwidth of dc to at least 50 MHz for single shot events with facilities for external triggering of the timebase. A suitable means of termination (50 ohm feedthrough or 50 ohm input impedance) shall be provided for the current probes where appropriate. A means of recording the oscilloscope trace shall be provided such that representative waveforms may be included in the test report. For the voltage measurements to be made a suitable high voltage probe or high impedance, high voltage divider will be required that has a frequency response as defined for the oscilloscope. It should be noted that as the duration of the transients is short the voltage rating of the probe may be higher than the dc rating.

### **3. SUSCEPTIBILITY CRITERIA**

The Equipment Test Plan shall specify the criteria for malfunction or degradation of performance such that the test engineer may readily determine whether or not the EUT has failed during test. Whilst not every possible failure mode can be predicted none the less the normal operating requirements of the EUT should be clearly described. The threshold of susceptibility is the minimum level of interfering signal at which a specified malfunction or degradation takes place and should be noted.

### **4. TRANSIENT GENERATORS**

#### **4.1 NEMP and HF Lightning induced Transients**

The transient generator for this test method shall provide a damped sinusoidal waveform, the resonant frequency of which shall be tuneable anywhere in the frequency range 2 to 30 MHz. The injection probe shall be an ERA Type 36 or 45. The use of the ERA Type 36 probe is preferred where space on the loom permits. The damping of the waveform shall be such that the amplitude of the eighth half cycle shall be at least 25 per cent but not more than 75 per cent that of the second half cycle as shown in Figure 5. The damping of the waveform shall be verified by injecting into a calibration jig terminated at each end in a 50 ohm load resistance. The damping of the waveform shall comply with the requirements specified above for all transients above 50 volts. The probe calibration jig shall be as shown in Figure 6.

It should be noted that the damping is specified when injecting into an effective loop impedance of 100 ohms. When applying the transient to a cable loom the damping may vary considerably from the calibration value. This is normal and is a function of the response of the loom under test. Additional information on the design of the pulse generator may be found in RAE Technical Memorandum FS(F) 550 (Ref 7)

#### **4.2 Ground Voltage Transient Generators**

The pulse generator for this test method shall produce a unipolar pulse of both positive and negative polarities, selectable by the test engineer during the test. The waveforms shall be as shown in Figures 7 and 8 and shall be verified for both open circuit output and for a load resistance of 1 ohm. The waveform shall be as specified for all transient voltages above 50 volts, with a time accuracy of  $\pm 20$  per cent.

\*\*\*\*\* WARNING \*\*\*\*\*

## 5. HEALTH AND SAFETY AT WORK.

IT MUST BE NOTED BY ALL OPERATORS AND TRIALS ENGINEERS THAT BOTH THE PULSE GENERATORS DESCRIBED ABOVE CONTAIN AND WILL PRODUCE LETHAL VOLTAGES. IT IS ESSENTIAL THAT GREAT CARE IS EXERCISED IN THE USE OF THESE GENERATORS AND THAT THE NECESSARY SAFETY PROCEDURES ARE USED.

\*\*\*\*\* WARNING \*\*\*\*\*

## 6. TEST METHODS

### 6.1 EMP and HF Lightning Effects

If cw bulk current injection testing is to be performed according to the test methods described in RAE Technical Memorandum FS(F)510 this shall be undertaken prior to the transient test method to be described here. This is in order to determine if the EUT has any susceptibilities in the frequency range 2 to 30 MHz. If any susceptibilities are found they shall be recorded for use in this test.

Before transients are applied to the cable looms of the EUT it will be necessary to measure the bulk rf impedance of the looms over the frequency range 2 to 30 MHz at the entry points to the EUT boxes. These measurements will determine whether there are frequencies where the cable looms have maximum and minimum impedances (i.e. maximum voltage and current coupling to the cable). These cable loom resonances could have a significant effect on the apparent equipment susceptibility and hence need to be determined.

The test has two main sections: (a) the selection of transient injection frequencies from cable impedance measurements and the cw current injection testing if it has been performed. (b) the transient injection testing and monitoring the EUT for susceptibility. For both of these tests it will be necessary to measure the induced cable current and the induced cable loop voltage. The current induced in the cable shall be measured by a suitable current probe as defined in section 2.7.2. A small single turn monitor loop is fitted around the injection probe for monitoring the voltage. This shall be connected to the measuring instrument such that the load impedance on the output of this loop is not greater than 20 pF or less than 4000 ohms, thus ensuring that the coil is neither loaded nor has resonances induced. Figure 9 shows such a loop.

For primary power lines the test shall be made at the EUT connector end of the cable. For other cables the test shall be applied at each end of the cable where the cable under test is linking two or more EUT boxes. A spacing of 50 mm shall be maintained between the EUT connector shell or any extension of

that shell and the faces of the current monitoring probe and the injection probe. This is shown in Figure 10.

#### **6.1.1 Selection of transient Injection Frequencies**

To measure the cable loom impedance, low level swept cw signals shall be injected into the interconnecting cableforms or powerlines under test over the frequency range 2 to 30 MHz, using the ERA 45 injection probe. The ratio of the injected cable voltage to injected cable current is a measure of the modulus of the cable's bulk rf impedance.

Prior to the measurement of the loom impedance the measurement system shall be calibrated such that any aberrations in the system may be removed. This is performed by the use of the setup shown in Figure 11. The use of a network analyser or similar is required. Approximately 1mW of power is applied to an ERA45 probe sweeping the frequency range 2 to 30 MHz. A short turn of wire is placed around the probe as shown such that the induced driving voltage around the loop may be measured. The use of a loop as defined in section 6.1 above is advised. The ERA45 probe is placed on a short loop of wire that is terminated in a known value of resistance, typically 100 ohms. The resulting induced current in this loop is monitored with a measurement probe as defined in section 2.7.2 above. The network analyser is set to display the voltage divided by current against frequency hence impedance is obtained. The display should at this stage have no major aberrations. Normalisation may be used to obtain a flat amplitude response at this stage. The terminating resistor may be changed to a different value, that is for example 20dB higher and then 20dB lower, in order to demonstrate that the measurement system is functioning correctly.

The measurement system is now ready to measure the bulk rf impedance of the interconnecting cable looms. If the normalisation has been applied then the resonances that may be present in the impedance of the loom will have the correct relative amplitudes. The test set up for these measurements is shown in Figure 10. A plot of the cable loom impedance shall be included in the test report.

#### **6.1.2 Transient Injection Testing**

Having measured the cable loom impedances the transient injection shall take place. Transients shall be injected at the frequencies listed in the following three sections:-

(a) The most susceptible frequencies in the range 2 to 30 MHz found from the cw bulk current injection test (assuming that this test has been performed and that any susceptibilities were found).

(b) The frequencies at which maxima and minima cable impedances occurred (found from the method of section, 6.1.1).

(c) Over the frequency range 2 to 30 MHz inclusive not less than 50 frequencies such that any resonances in the EUT

internal circuitry are excited so subjecting any active or passive devices to maximum voltage or current threat. These frequencies shall be spaced evenly with a logarithmic increment. The frequency of each injection is obtained by the use of the following equation:

$$\text{Test frequency (MHz)} = 10 \wedge (0.301 + 0.024 * K)$$

for K = 0,1,2,3 to 49 for 50 increments.

NB. There are 50 test frequencies. Table 1 gives the frequencies obtained with this formula for 50 increments

The requirement is for a minimum of 50 frequencies and the selection of individual frequencies as defined above is such that an even distribution is obtained. Obtaining exact frequencies is not critical, it is more important that the frequency range be covered adequately. It may be found that the tuning arrangement on the pulse generator used, will lend itself to a higher number of injection frequencies with greater ease of use, this is acceptable.

The transients shall be injected using the test configuration shown in Figure 12. The frequency of the generator shall be finely tuned for (a) above. The frequency shall also be finely tuned for (b) above such that maximum induced voltage for high impedance or maximum induced current for low impedance is produced. It should be noted that the resonant frequency of the damped sinusoid varies slightly during the transient as a result of coupling effects with loom resonances. The frequency measurement should thus be obtained from an average over several zero crossings of the waveform.

### 6.1.3 Test Limits for Damped Sinusoidal Testing

The EUT shall not exhibit any malfunction, degradation of performance, damage or deviation from the equipment's individual specification when subjected to pulses up to and including the following test limits and conditions. The transient induced cable current shall be measured with the current probe and the transient voltage shall be measured by means of the loop around the injection probe.

At least 5 transients shall be injected at each frequency and at maximum amplitude as defined below whilst the EUT is monitored for degradation or malfunction. The time interval between transients shall be a minimum of 2 seconds in order to ensure that the generator gives the required output for each pulse. It should be noted that with digital systems if the EMP/lightning pulse coincides with clocking pulses or other data transfer actions data corruption could occur. It may be necessary to inject more pulses in order to achieve confidence of required error rates. This latter situation should be identified in the test plan. If a susceptibility occurs the transient level shall be reduced to obtain the threshold of malfunction. The test report shall contain details of the induced transient current and probe loop voltage in addition to the frequencies selected for test. The loom current at each

frequency is to be recorded graphically together with an indication of where failure has occurred during this test.

Suggested levels for the maximum induced current, the maximum probe loop voltage and the maximum volt-amp product of the current and voltage are:

20 amperes peak current  
2000 volts peak voltage  
10 kilo volt-amperes.

The test limit will have been reached when any one of the above criteria has been met. For low impedance cables the current limit will usually be reached first, for high impedance cables the voltage limit will be reached first and for others the volt-amp product. The volt-amp product is that obtained by taking the product of the maximum induced current value and the maximum probe voltage taking no account of the relative time at which the maxima occur or of their sign. Using this approach gives a reasonably simple method of ensuring that the test takes account of variations of cable impedance and hence reduces the possibility of an overtest.

The above test limits are based upon the estimated current induced into equipment cables in the fuselage of an attack type military aircraft. For any project application, test levels should be the subject of an assessment taking account of the aircraft size, fuselage screening and degree of overtest required to meet hardness assurance requirements. The values given above should only be used as guidelines.

## **6.2 Lightning Ground Voltage Injection**

For this test method the effects of variations in the "ground potential" of the grounding point of the EUT during a lightning strike are assessed. Where equipments are mounted within 0.5 m of each other with ground bonding within 0.5 m to the same part of the aircraft structure then such equipments shall be treated as one for this test. If the equipments are close together but with connections or bonds to different parts of the structure, such as equipments mounted on an engine casing connecting with an equipment mounted within the engine nacelle, then such equipments shall be treated as separate devices.

It is necessary to insulate the case of the EUT from the ground plane with an insulation material capable of withstanding 1600 volts. Any ground bonding straps to the EUT shall be removed together with any connections to ground as described above.

A connection between the output of the pulse generator and the EUT case bonding location, or if this is not provided then a suitably cleaned attachment point, shall be made. Any electrical wiring as described above shall also be connected to the pulse generator output. Figure 13 shows a typical test arrangement. These connections shall be both short and of as low an impedance as possible.



The pulse generator shall be earthed to the ground plane with a short, low inductance bonding strap, the impedance to ground being less than 10 milliohms at dc.

The output voltage and current of the pulse generator shall be measured with a storage oscilloscope with the input terminated by a suitable 50 ohm feedthrough. The pulse generator described in RAE Technical Memorandum FS(F)550 incorporates outputs for both current and voltage measurements by an oscilloscope with a 50 ohm input impedance.

### **6.2.1 Transient Testing**

The EUT shall be set up as detailed in sections 2 and 6.2 then operated in accordance with the Test Plan. Two test waveforms are to be applied, the first has a rise time of approximately 2us and fall time of 150us, whilst the second has a 50ns rise time and 2us fall time. At least 10 transients of each type shall be applied at the amplitudes listed in section 6.2.2 within a period of one minute. The amplitude should be increased gradually to these levels whilst the EUT is monitored for malfunction or degradation.

### **6.2.2 Test Limits For Ground Voltage Injection**

The test limit will be deemed to have been met when either the voltage or the current limits tabled below have been reached. If a degradation in performance or malfunction occurs then the output level of the pulse generator shall be adjusted to determine the threshold of malfunction. The current and voltage levels at the threshold of malfunction shall be recorded. The test report shall record the currents and voltages whether or not a susceptibility occurs, if a susceptibility has occurred then the nature of that shall also be recorded.

The levels of voltage and current to be applied are based on those levels recommended in the SAE AE4L committee report: Test Waveforms and Techniques for Assessing the Effects of Lightning-Induced Transients dated 15th December 1981. The level to be applied is based on the type of equipment and position within the aircraft. To be consistent with the SAE document the same level classifications are used. These are:

Level 1. Not considered appropriate for military equipments.

Level 2. Intended for equipment which will be installed in environments where lightning induced transients would be controlled to a level which is consistent with that represented by FS(F)510 or DEF STAN 59-41 or similar standards. This level is considered to be consistent with good engineering practice for such equipment and should have a relatively minor impact on the associated design practices.

Level 3. Is representative of the more intense transients which may be experienced during normal operations.

Level 4. Is representative of severe transients which may appear on power lines. The power associated with this level is relatively severe and its impact on equipment design practices will probably be significant.

Level 5. This is an upper limit on transients to which subsystem equipment should be exposed. Transients which lightning could induce in long and/or exposed wiring should be controlled to be consistent with this test level. The power level associated with this level represents a severe threat to most electronic circuits and the impact on equipment design will be significant. The voltage levels will in addition stress insulation materials of items such as connectors and transformers.

These levels have the following voltage and current limits:

Level	Voltage Limit Volts	Current Limit Amperes
2	125	25
3	300	60
4	750	150
5	1600	320

The Equipment Test Plan shall indicate which of the test levels shall apply to each EUT, or indeed another level which is seen as realistically representing the stress to an equipment in a particular application. Both polarities of pulse shall be applied to the appropriate limit as specified above.

## **7. ACCEPTANCE TESTING OF EQUIPMENT POST TRIAL**

The transients described in this Memorandum may have damaging effects on the EUT which may not preclude apparently normal functioning of the EUT. Such effects may be the destruction of filter components etc. In order to verify that this has not occurred a full acceptance test of the EUT shall be made at the end of the trials. Details of any such damage must be included in the Test Report.

## **8. CONCLUSION**

The test methods described in this Memorandum are based on extensive application at the Royal Aircraft Establishment and have been modified to make them more easily used. The pulse generators to perform the tests are available and also described in the documents referenced.

It is emphasised that the test levels given are for guidance only and the levels to be used need to be defined for a particular project and application.

The test methods and limits may well be changed in the future to reflect better knowledge of the problems and changes in equipment designs. It is intended to produce modified test documents in the future as further issues of this Memorandum.

Whilst the test levels may at first seem high, they have been used on avionic equipments. In general if adequate EMC hardening has been applied equipments should pass the EMP test with little or no modification.

## **9. ACKNOWLEDGEMENTS**

The author is grateful for the help and guidance of Dr J. Bishop, Supt. of FS(F)5 Division, in the development of the EMP test method in this Memorandum.

**TABLE 1. TEST FREQUENCIES GIVEN BY EQUATION 6.1.2(c)**

Test number	MHz	Test number	MHz
1	2.0	26	8.0
2	2.1	27	8.3
3	2.2	28	8.8
4	2.4	29	9.3
5	2.5	30	9.8
6	2.6	31	10.5
7	2.8	32	11.1
8	2.9	33	11.7
9	3.1	34	12.4
10	3.3	35	13.1
11	3.5	36	13.8
12	3.7	37	14.6
13	3.9	38	15.5
14	4.1	39	16.3
15	4.3	40	17.3
16	4.6	41	18.2
17	4.8	42	19.3
18	5.1	43	20.4
19	5.4	44	21.5
20	5.7	45	22.8
21	6.0	46	24.0
22	6.4	47	25.4
23	6.7	48	26.9
24	7.1	49	28.4
25	7.5	50	30.0

As stated previously in section 6.1.2 the requirement is that the frequency range be covered evenly on a logarithmic basis. Thus the individual frequency accuracy is less important than the need to cover the frequency range.

## REFERENCES

- | No. | Author     | Title, etc  |
|-----|------------|---|
| 1.  | R. Penny   | An EMP hardness control plan for avionic systems. RAE Technical Memorandum FS(F)457 (1982)  |
| 2.  | G A Odam   | Lightning transients that affect aircraft avionic equipment; a review of waveforms, levels and test methods. RAE Technical Memorandum (in preparation)                      |
| 3.  | G A Odam   | Lightning protection requirements for aerospace vehicles. RAE Technical Memorandum FS(F)632 (in preparation)  |
| 4.  | N J Carter | Recommended test specification for the electromagnetic compatibility of aircraft equipment. RAE Technical Memorandum FS(F)510 (1986)  |
| 5.  | R A Hobbs  | Design and construction of line impedance stabilising networks. RAE Technical Memorandum FS(F)613   |
| 6.  | G D Barber | The design, performance and calibration of probes 36A, 37A, 40A, 43A, 45A and 50A for bulk current susceptibility tests. RAE Technical Memorandum FS(F)588 (in preparation) |
| 7.  | R A Hobbs  | The design and construction of pulse generators to comply with the requirements of RAE Technical Memoranda FS(F)457 issue 2 and FS(F)510 (in preparation)                   |

### INDEX TO FIGURES

- Figure 1. Details of line impedance stabilisation network (LISN)
- Figure 2. Impedance characteristics of LISN
- Figure 3. Modification to dc supplies to limit surge current
- Figure 4. Typical test layout on ground plane
- Figure 5. Damped sinusoidal waveform requirements
- Figure 6. Calibration jig and monitoring for verification of waveform
- Figure 7. Waveform for long ground voltage transient
- Figure 8. Waveform for short ground voltage transient
- Figure 9. Voltage measurement loop on injection probe
- Figure 10. Test set up for loom impedance measurements
- Figure 11. Calibration of impedance measurement system
- Figure 12. Test set up for sinusoid injection
- Figure 13. Test set up for ground voltage injection

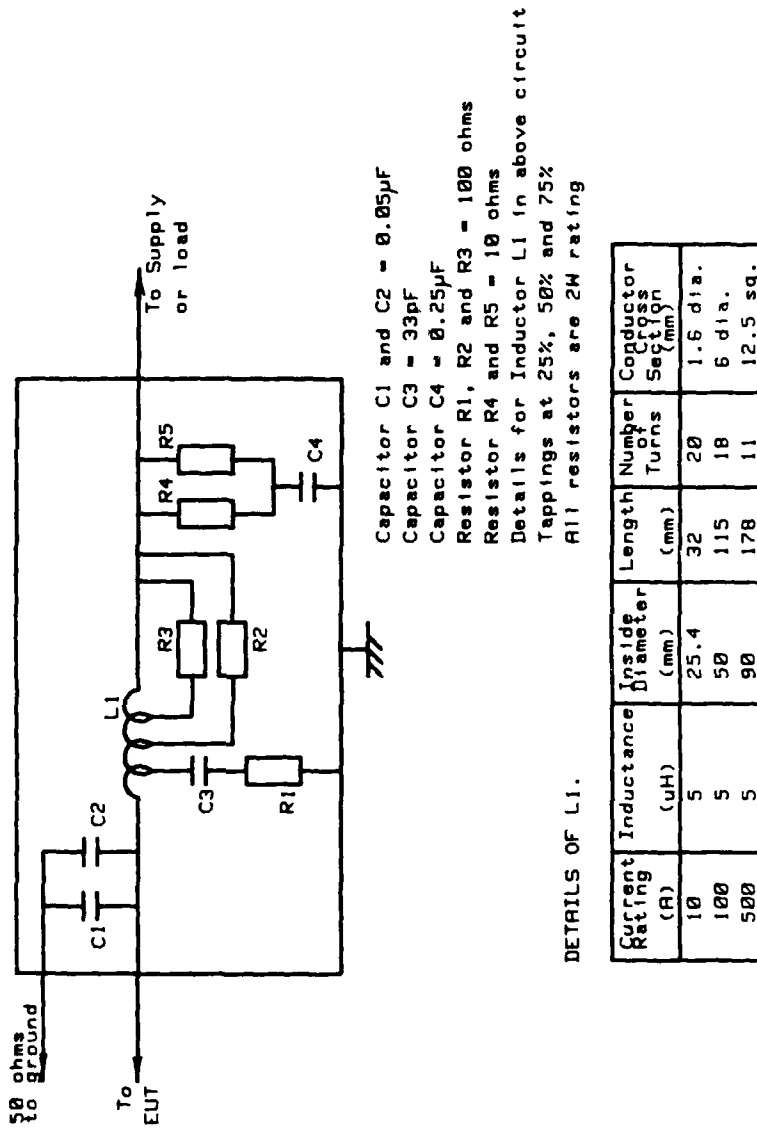

Capacitor C1 and C2 = 0.05 $\mu$ F  
 Capacitor C3 = 33pF  
 Capacitor C4 = 0.25 $\mu$ F  
 Resistor R1, R2 and R3 = 100 ohms  
 Resistor R4 and R5 = 10 ohms  
 Details for Inductor L1 in above circuit  
 Tappings at 25%, 50% and 75%  
 All resistors are 2W rating

DETAILS OF L1.

Current Rating (A)	Inductance ( $\mu$ H)	Inside Diameter (mm)	Length (mm)	Number of Turns	Conductor Cross Section (mm)
10	5	25.4	32	20	1.6 dia.
100	5	50	115	18	6 dia.
500	5	90	178	11	12.5 sq.

Figure 1. Details of line impedance stabilisation network (LISN)

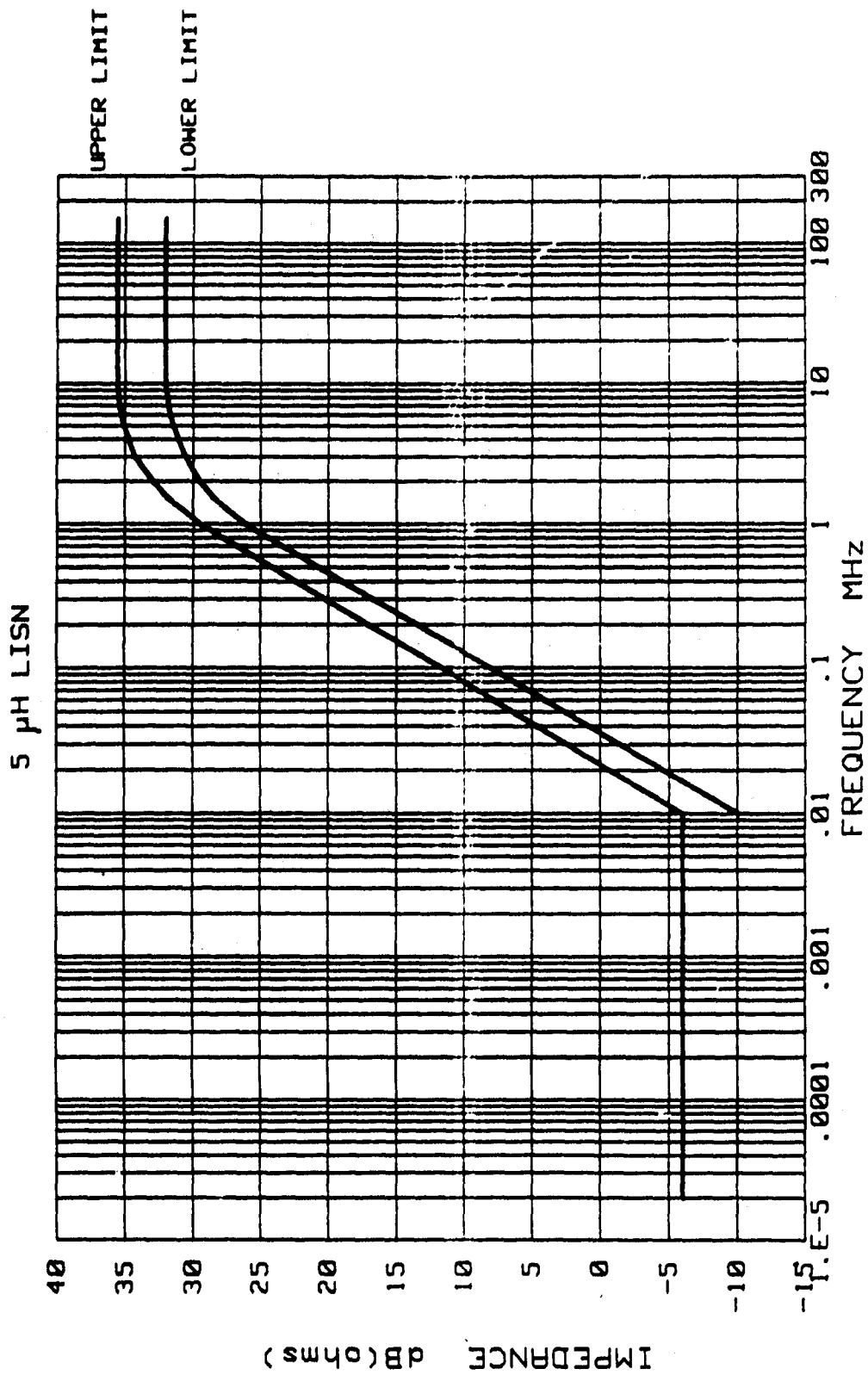

Figure 2. Impedance characteristics of LISN



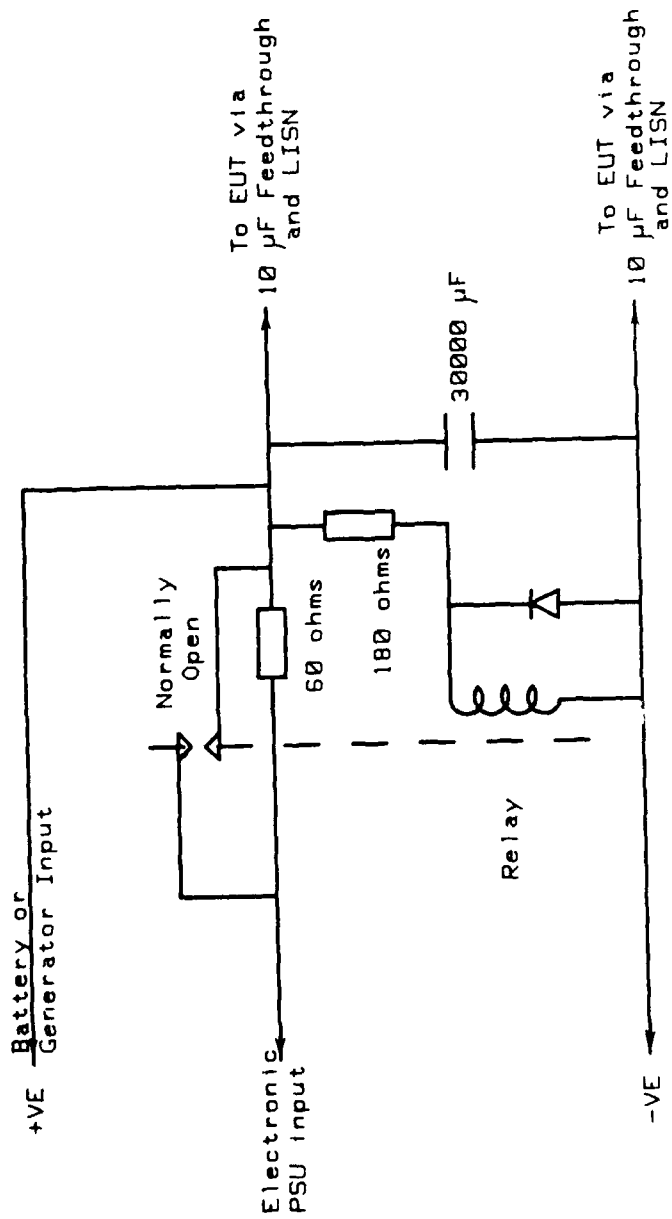

Figure 3. Modification to dc supplies to limit surge current

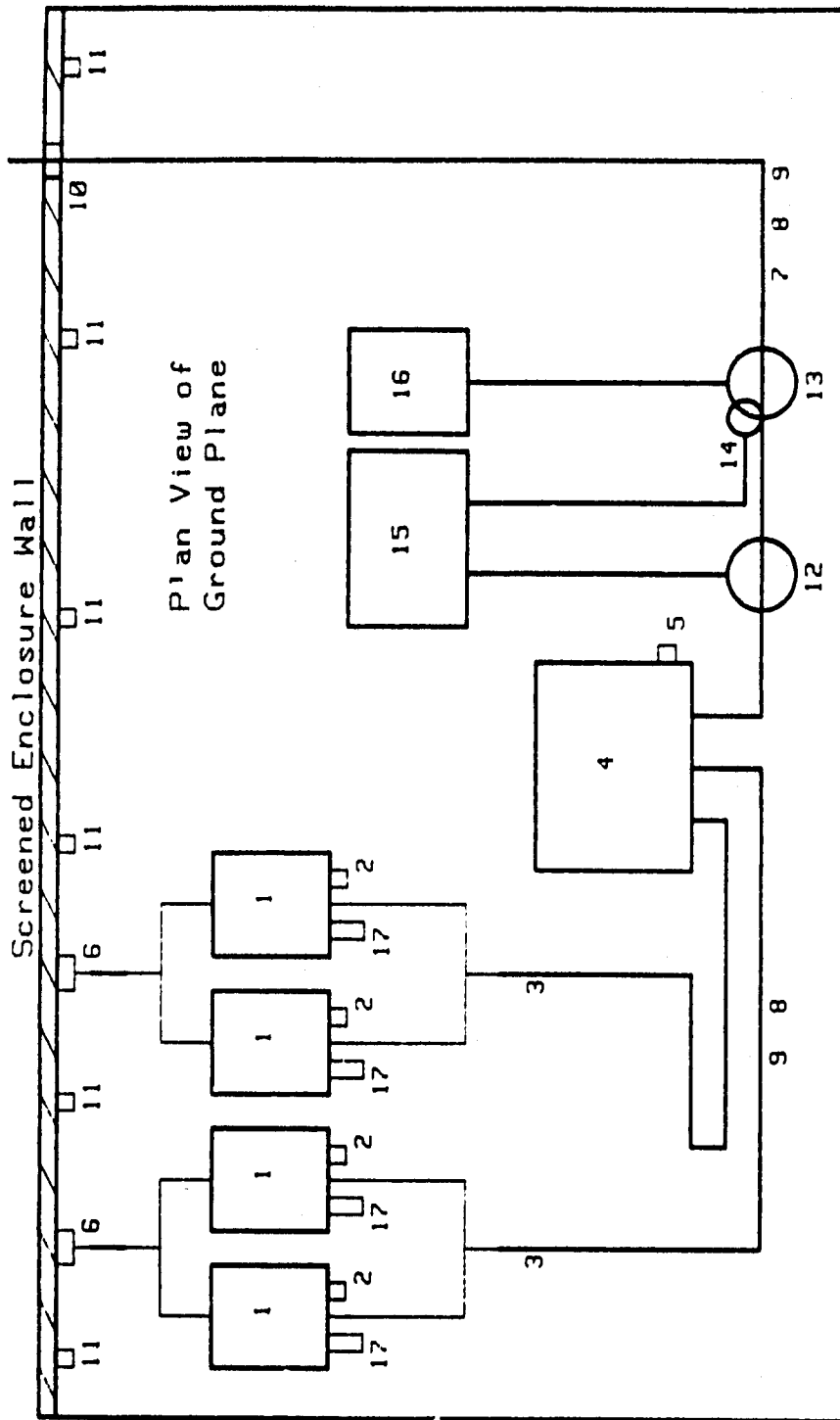
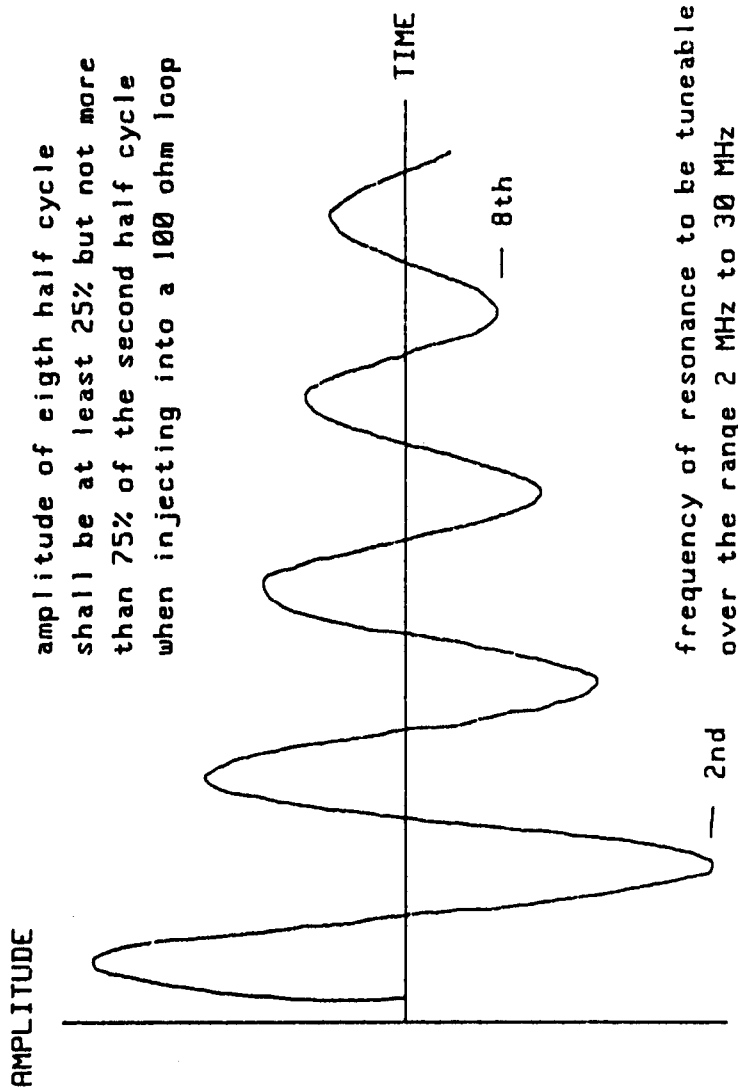

Figure 4. Typical test layout on ground plane

1. LISN and 10uF feedthrough capacitor.
2. Bond to ground plane.
3. EUT power leads, 1 metre total length, separated 300 mm from LISN.
4. EUT situated with its face 100 mm +/- 20 mm from front edge of ground plane.
5. Bond to ground plane for EUT; as defined.
6. Filtered power supply terminals at screened enclosure wall.
7. EUT interconnecting lead; length as defined in Test Set-Up and Para. 5.8.
8. Power leads and interconnecting leads to be situated 100 mm +/- 20 mm from front edge of ground plane.
9. Power leads and interconnecting leads to be supported 50 mm above ground plane via insulated stand-offs.
10. Interconnecting lead to monitoring equipment; test set via conduit, feedthrough connectors or filters.
11. Ground plane dc bond to screened enclosure wall shall be less than 2.5 milliohms.
12. Measuring Current Probe. 13. Injection Probe.
14. Monitor Turn around Injection Probe together with Oscilloscope Probe. 15. Receiver or Oscilloscope.
16. Spike Generator or cw Signal Source.



WAVEFORM REQUIREMENTS FOR DAMPED SINUSOIDS

Figure 5. Damped sinusoidal waveform requirements

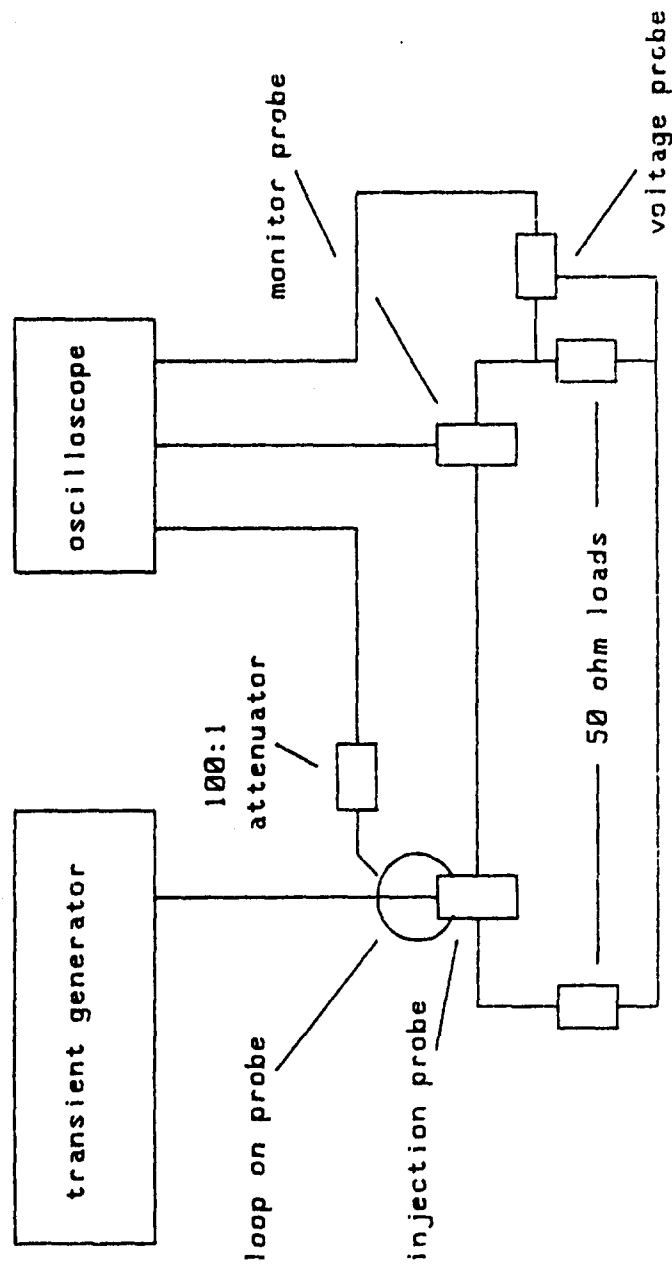

CALIBRATION OF TRANSIENT GENERATOR

Figure 6. Calibration jig and monitoring for verification of waveform

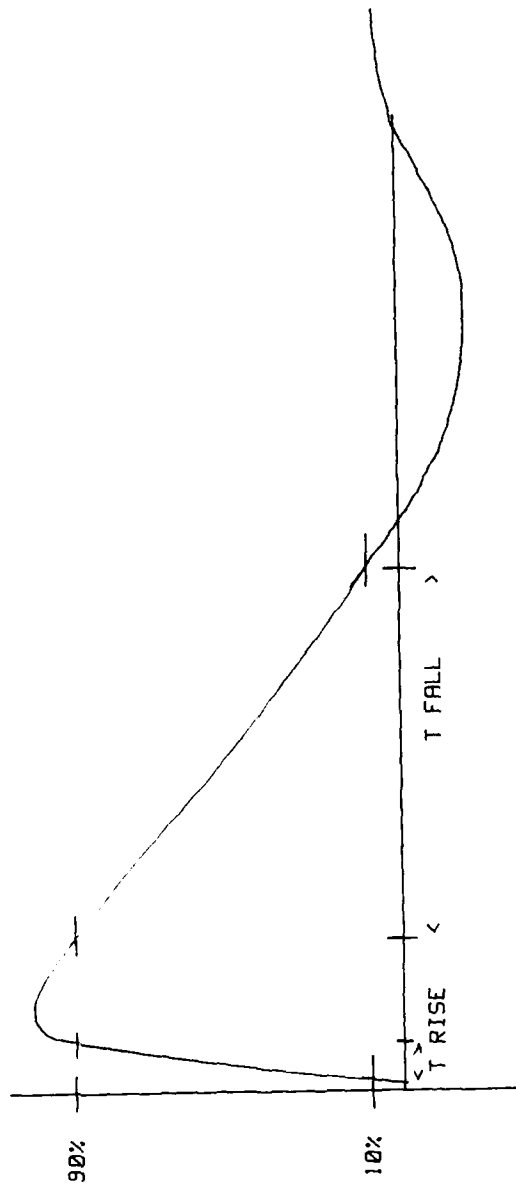

10% - 90% risetime shall be 1 microsecond  $\pm 20\%$   
 90% - 10% falltime shall be 150 microseconds  
 overshoot in resistive load shall be less than 20% of max amplitude

LIGHTNING GROUND VOLTAGE INJECTION - LONG PULSE

Figure 7. Waveform for long ground voltage transient

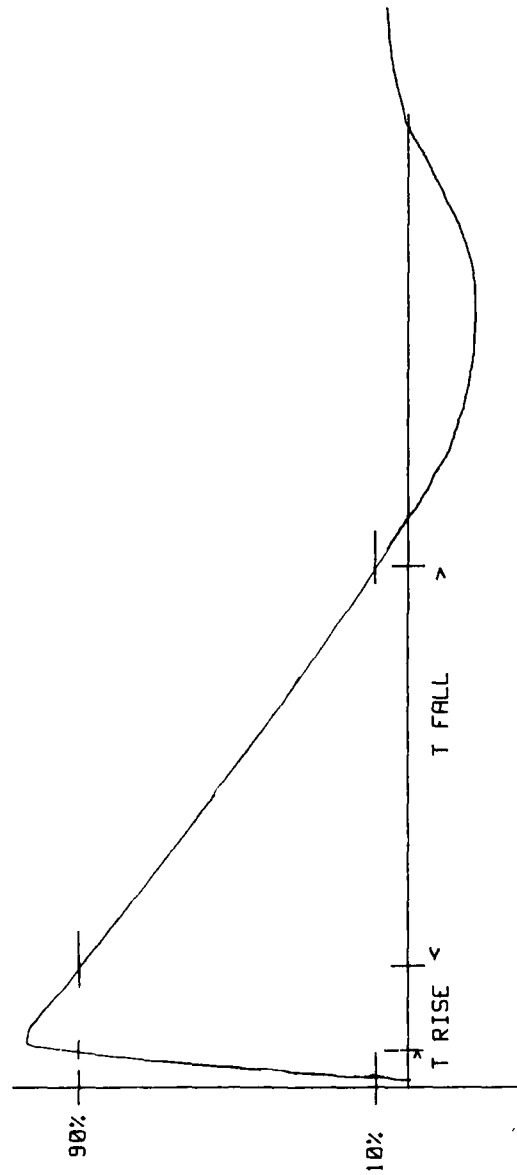

10% - 90% risetime shall be 50 nanoseconds or less

90% - 10% falltime shall be 2 microseconds  $\pm 20\%$

overshoot in resistive load shall be less than 40% of max amplitude

LIGHTNING GROUND VOLTAGE INJECTION - SHORT PULSE

Figure 8. Waveform for short ground voltage transient

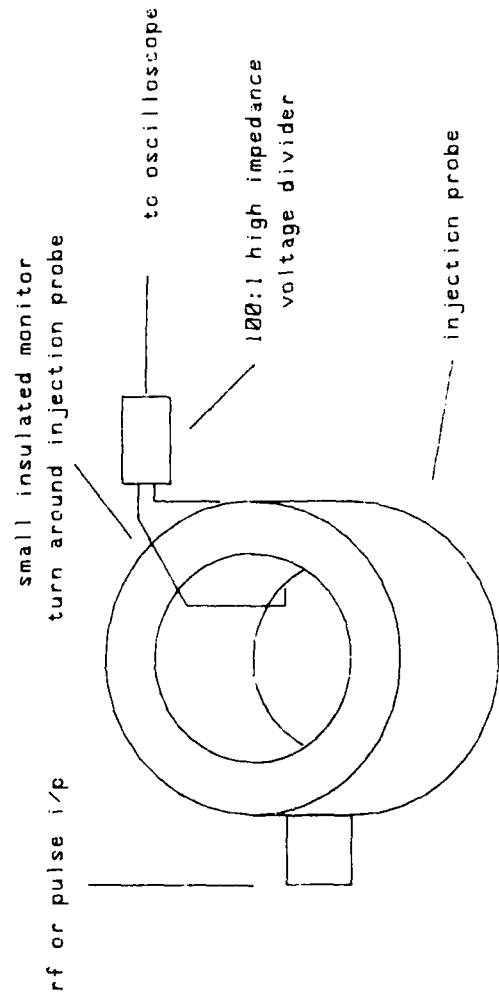

MONITOR LOOP ON INJECTION PROBE

Figure 9. Voltage measurement loop on injection probe

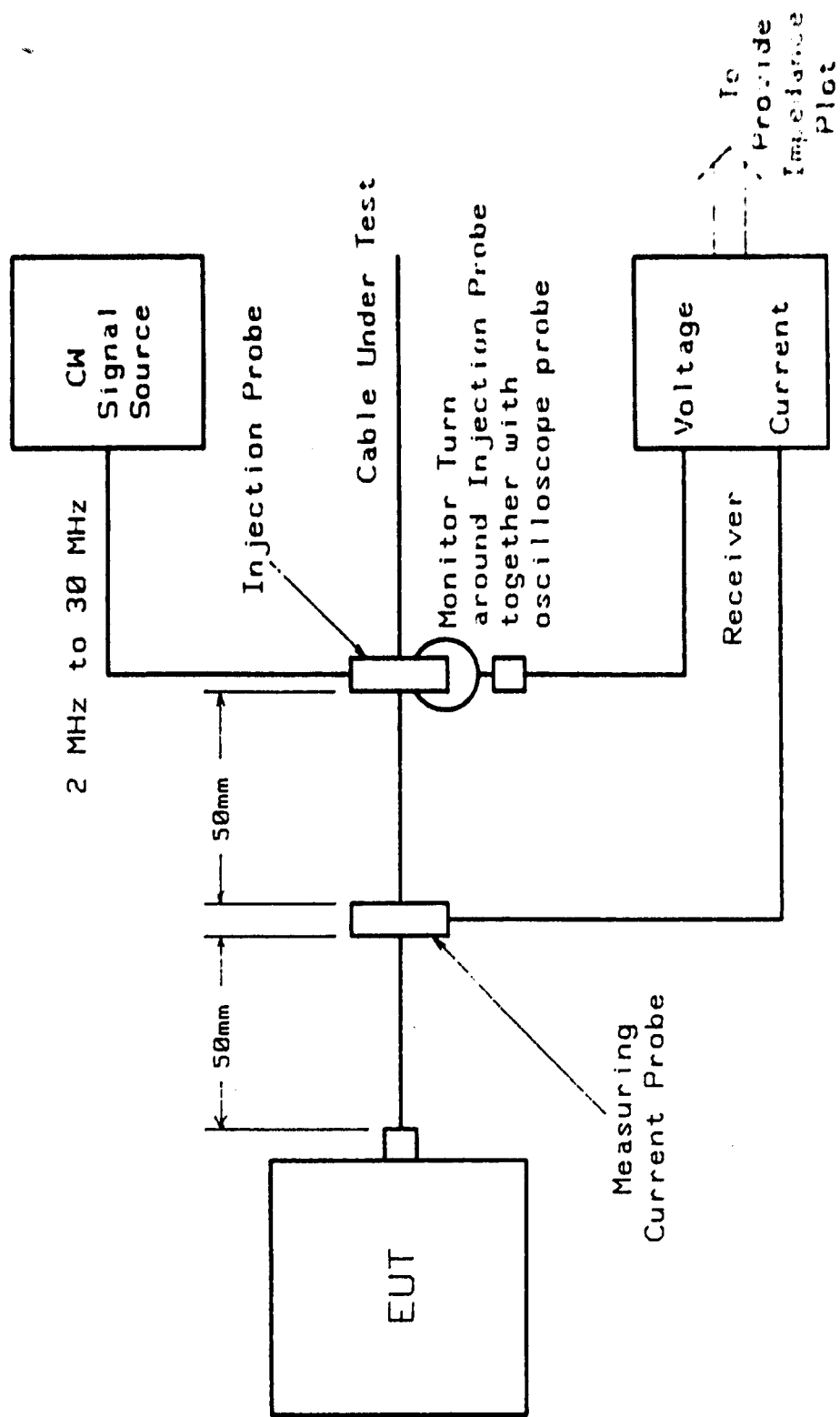
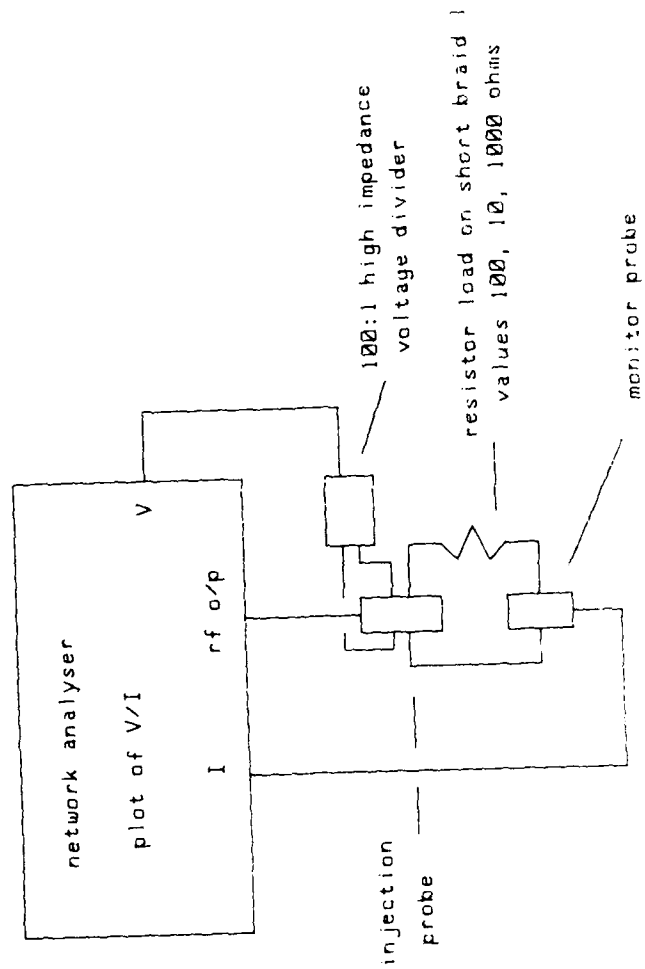

Figure 10. Test set up for 100m impedance measurements





CALIBRATION OF CW MEASUREMENT SYSTEM

Figure 11. Calibration of impedance measurement system

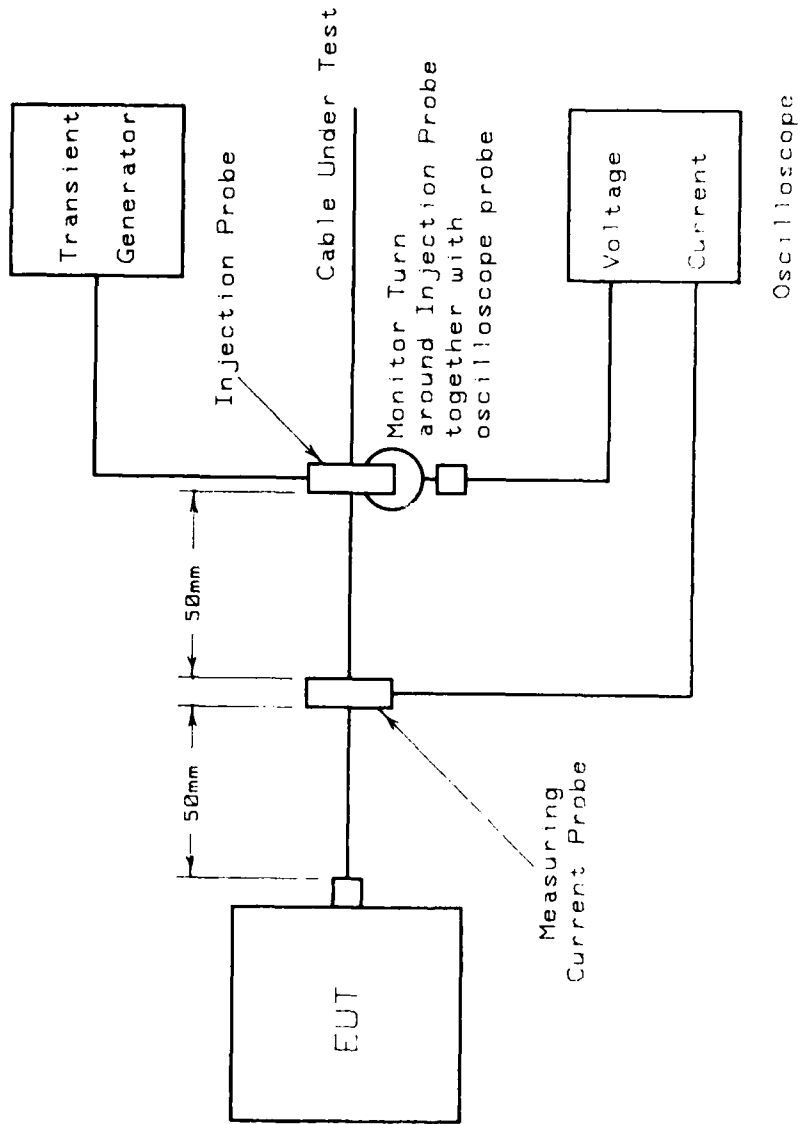
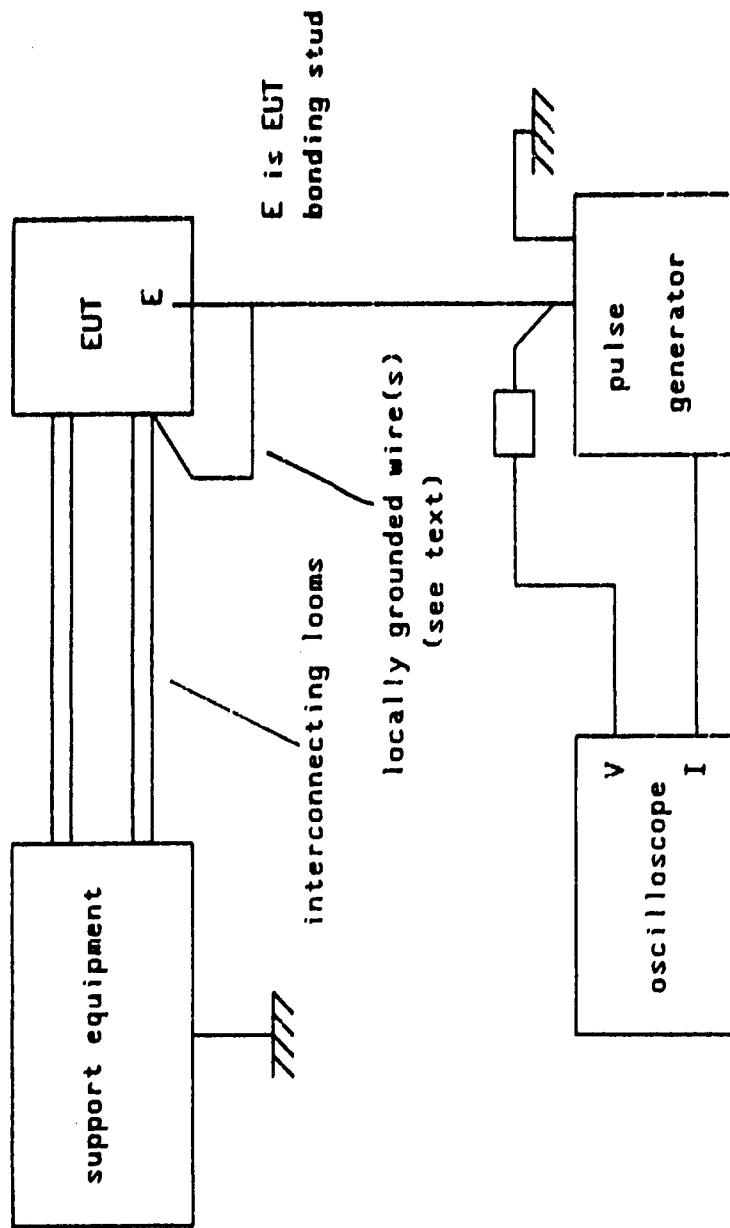

Figure 12. Test set up for sinusoid injection



TEST SETUP FOR GROUND VOLTAGE INJECTION

Figure 13. Test set up for ground voltage injection

REPORT DOCUMENTATION PAGE

Overall security classification of this page

UNCLASSIFIED

As far as possible this page should contain only unclassified information. If it is necessary to enter classified information, the box above must be marked to indicate the classification, e.g. Restricted, Confidential or Secret.

1. DRIC Reference (to be added by DRIC)	2. Originator's Reference RAE TM FS(Y) 457	3. Agency Reference	4. Security Classification/Marking <b>UNCLASSIFIED</b>
5. DRIC Code for Originator 7673000W		6. Originator (Corporate Author) Name and Location Royal Aircraft Establishment, Farnborough, Hants, UK	
5a. Sponsoring Agency's Code		6a. Sponsoring Agency (Contract Authority) Name and Location	
7. Title Equipment test methods for externally produced electromagnetic transients			
7a. (For Translations) Title in Foreign Language			
7b. (For Conference Papers) Title, Place and Date of Conference			
8. Author 1. Surname, Initials Hobbs, R.A.	9a. Author 2	9b. Authors 3, 4 ...	10. Date July 1987   Pages 34   Refs. 7
11. Contract Number	12. Period	13. Project	14. Other Reference Nos.
15. Distribution statement (a) Controlled by –  (b) Special limitations (if any) – If it is intended that a copy of this document shall be released overseas refer to RAE Leaflet No.3 to Supplement 6 of MOD Manual 4.			
16. Descriptors (Keywords) (Descriptors marked * are selected from TEST)			
17. Abstract  This Memorandum is the result of the work at the Royal Aircraft Establishment in assessing the effect of electromagnetic pulse and lightning strike produced transients to aircraft systems. It details suitable tests for the simulation of these effects and should be used to form the basis of any future aircraft project transient specifications with suitable tailoring to meet specific requirements with the formal approval of the Project Director.			

F3910/1