

AD-A190 686

PROCESS FOR ASSESSING THE STABILITY OF HAN  
(HYDROXYLAMINE)-BASED LIQUID B. (U) FRAUNHOFER-INST  
FUER TREIB- UND EXPLOSTOFFE PFINZTAL-BERCH.

1/1

UNCLASSIFIED

R HANSEN ET AL. 29 MAY 87 DAJA45-86-C-0056 F/G 21/9.1 ML

END  
28

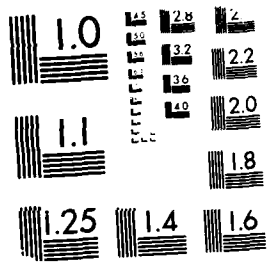

MICROCOPY RESOLUTION TEST CHART  
NATIONAL BUREAU OF STANDARDS-1963-A

FRAUNHOFER-INSTITUT  
FÜR TREIB- UND EXPLOSIVSTOFFE



③

DTIC FILE COPY

AD-A190 686

PROCESS FOR ASSESSING THE STABILITY  
OF HAN-BASED LIQUID PROPELLANTS  
1st Interim Report

by

Dr. R. Hansen

Dr. E. Backof

Dr. H.J. de Greiff

February 1987

United States Army

EUROPEAN RESEARCH OFFICE OF THE U.S. ARMY

London England

CONTRACT NUMBER DAJA 45-86-C-0056

DTIC  
ELECTE  
FEB 1 2 1988  
S E D

This document has been approved  
for public release and sale; its  
distribution is unlimited.

7507 PFINTAL - BERGHAUSEN  
BEI KARLSRUHE

SECURITY CLASSIFICATION OF THIS PAGE (When Data Entered)

REPORT DOCUMENTATION PAGE		READ INSTRUCTIONS BEFORE COMPLETING FORM
1. REPORT NUMBER 1st Interim Report	2. GOVT ACCESSION NO.	3. RECIPIENT'S CATALOG NUMBER
4. TITLE (and Subtitle) Process for Assessing the Stability of HAN-Based Liquid Propellants		5. TYPE OF REPORT & PERIOD COVERED 1st Interim Report 9 December 86-9 February 87
		6. PERFORMING ORG. REPORT NUMBER 19-101-664
7. AUTHOR(s) Dr. K. Hansen Dr. E. Backof Dr. H. J. de Greiff		8. CONTRACT OR GRANT NUMBER(s) DAJA 45-86-C-0056
9. PERFORMING ORGANIZATION NAME AND ADDRESS Fraunhofer-Institut für Treib- und Explosivstoffe (ICT), Joseph-von-Fraunhofer-Strabe D-7507 Pfinztal-Berghausen (West Germany)		10. PROGRAM ELEMENT, PROJECT, TASK AREA & WORK UNIT NUMBERS Task description 4.2 (work schedule 2.2, 3.1.1)
11. CONTROLLING OFFICE NAME AND ADDRESS Fraunhofer-Gesellschaft Leonrodstr. 54 D-8000 München, West Germany		12. REPORT DATE 29 May 1987
		13. NUMBER OF PAGES 20
14. MONITORING AGENCY NAME & ADDRESS (if different from Controlling Office) Bundesministerium der Verteidigung, 5300 Bonn 1 (MOD) der Bundesrepublik Deutschland, West Germany		15. SECURITY CLASS. (of this report) Unclassified
		15a. DECLASSIFICATION/DOWNGRADING SCHEDULE
16. DISTRIBUTION STATEMENT (of this Report) To be decided by the USA CCE		
17. DISTRIBUTION STATEMENT (of the abstract entered in Block 20, if different from Report)		
18. SUPPLEMENTARY NOTES		
19. KEY WORDS (Continue on reverse side if necessary and identify by block number) Liquid Propellants, monergols (HAN-Based); Chemical Stability, Long Term Stability		
20. ABSTRACT (Continue on reverse side if necessary and identify by block number) The first intermediate report covers the selection of work materials and the subsequent treatment of work materials for the pressure sensors. During storage of the monergols containing HAN at a higher temperature (90 °C) hydroxylamine and nitric acid are produced apart from water vapor in the gas phase of the pressure container. The presence of these substances can be demonstrated in the distillate of LP 1846. Consequently, they are also capable of reacting with the work material of the pressure sensors and contaminating the sample during long-term storage of the liquid propellants. Continuation please see on the back		

DD FORM 1473 EDITION OF 1 NOV 65 IS OBSOLETE

SECURITY CLASSIFICATION OF THIS PAGE (When Data Entered)

88 2 09 157

Abstract (continued)

A report is given on storage trials with LP 1846 in glass ampules with the work material 17/4 PH of the provided pressure sensor, with alternative alloys (stainless steels), with weapon steel types and with alloy components and with precious metals coming into consideration as protective coating for pressure sensors.

The trial setup for determining the chemical stability of liquid propellants is described. A number of possibilities for long-term storage of monergols at increased temperatures and pressure recording are also discussed.

FRAUNHOFER-INSTITUT  
FÜR TREIB- UND EXPLOSIVSTOFFE



PROCESS FOR ASSESSING THE STABILITY  
OF HAN-BASED LIQUID PROPELLANTS  
1st Interim Report

by

Dr. R. Hansen  
Dr. E. Backof  
Dr. H. J. de Greiff

February 1987

United States Army

EUROPEAN RESEARCH OFFICE OF THE U.S. ARMY

London England

CONTRACT NUMBER DAJA 45-86-C-0056

Accession For	
NTIS GRA&I	<input checked="" type="checkbox"/>
PCIS DA	<input type="checkbox"/>
Unannounced	<input type="checkbox"/>
Justification	
By	
Distribution/	
Availability Codes	
Avail and/or	
Dist Special	
A-1	

BY  
FILED

7507 PFINTAL-BERGHAUSEN  
BEI KARLSRUHE

LIST OF CONTENTS

	page
1. <u>Abstract</u>	2
2. <u>Work Schedule of Project DAJA45-86-C-0056</u>	3
2.1 The development of analysis methods	
2.2 The determination of relevant test methods	
2.3 The provision of experimental proof of the influence of different impurities on chemical stability	
2.4 The improvement of stability through optimization of the pH value / decomposition during long-term storage	
2.5 Optimization of storage capacity through the addition of different stabilizers	
2.6 Measurement of gas composition after ignition	
3. <u>Test arrangement to determine the stability of liquid propellants</u>	5
3.1 <u>Long-term storage of monergols at raised temperatures</u>	5
3.1.1 <u>Storage in glass ampoules</u>	6
3.1.2 <u>Storage in glass containers with pressure sensors</u>	8
3.1.3 <u>Storage in glass ampoules with strain-gauges</u>	9
4. <u>The influence of pressure sensor materials on the life of liquid propellant samples</u>	11
5. <u>Annex (Figures and Tables)</u>	14

### 1. Abstract

The first intermediate report covers the selection of work materials and the subsequent treatment of work materials for the pressure sensors.

During storage of the monergols containing HAN at a higher temperature (90 °C) hydroxylamine and nitric acid are produced apart from water vapor in the gas phase of the pressure container. The presence of these substances can be demonstrated in the distillate of LP 1846. Consequently, they are also capable of reacting with the work material of the pressure sensors and contaminating the sample during long-term storage of the liquid propellants.

A report is given on storage trials with LP 1846 in glass ampoules with the work material 17/4 PH of the provided pressure sensor, with alternative alloys (stainless steels), with weapon steel types and with alloy components and with precious metals coming into consideration as protective coating for pressure sensors.

The trial setup for determining the chemical stability of liquid propellants is described. A number of possibilities for long-term storage of monergols at increased temperatures and pressure recording are also discussed.



## 2. Work Schedule of Project DAJA45-86-C-0056

The aim is to establish analysis procedures for the quantitative determination of the individual components of liquid propellants to be named by BRL and to conduct tests to determine its chemical stability, the influence of impurities on its storage, behaviour, its safety during handling and its storage life and to attempt to improve its chemical stability.

In order to determine and assess the decomposition products and the stability of the BRL monergol under consideration, the following test procedures are to be carried out:

- 2.1 The development of analysis methods to determine the components, decomposition products and impurities in the monergol
- 2.2 The determination of relevant test methods to simulate aging processes
- 2.3 The provision of experimental proof of the influence of different impurities (transition metal ions) on the chemical stability, giving details on the maximum effective limit concentrations in each case through:
  - The measurement of concentration changes in the individual components and determination of disintegration products ( $\text{NH}_4\text{NO}_3$ ,  $\text{HNO}_3$ ) during long-term storage in sealed containers at increased temperature
  - Measuring the pressure of the material through time during long-term storage in sealed pressure containers at increased temperature.

- Quantitative determination of disintegration gases given off as dependent on storage duration at increased temperature.

- 2.4 The improvement of stability through optimization of the pH value, and proof of stability improvement via the determination of component decomposition during long-term storage at increased temperature.
- 2.5 The attempt to optimize the shelf life (storage capacity) through the addition of different stabilizers additives).
- 2.6 The measurement of gas composition after ignition in a burning chamber subjected to increasing burning chamber initial pressures.

For performance of the trials, original US samples of NOS-365 (Lot H 240) and LP 1846 (Lot 49-1) were made available to us. The analysis values we determined are given, in summarized form, in Table 1: here, by way of comparison, the analysis values for LP 1845 samples made by ourselves from HAN produced by BASF and Thiokol. According to our analysis, the composition of the two US monergols, Lots H 240 and 49-1, differs from the formulation given to a considerable extent.

### 3. Test arrangement to determine the stability of liquid propellants

In the case of solid propellants, testing of the chemical stability is laid down by work specifications. Parameters for stability assessment can be obtained, for example, from tests on weight loss, stabilizer decomposition, demonstrating the presence of decomposition products, rise in pressure or also from the heat developed during thermic loading.

In the case of liquid propellants, however, it has not been possible to lay down any specific test specifications up till now. Test procedures - analogous to those for solid ones - are problematic for liquid propellants: this is because, during long-term storage, a continuous evaporation of the readily volatile components takes place, producing - instead of the originally insensitized propellant - an instable material sensitive to manipulation. For this reason, a test procedure must be applied which prevents a partial evaporation of substances from the liquid during the simulation of aging processes. From this it follows that the test substances must be enclosed in a hermetically sealed system capable of withstanding the pressure occurring during the storage period. All test methods in which this problem cannot be mastered are only capable of producing inaccurate results.

#### 3.1 Long-term storage of monergols at raised temperatures

In order to assess their storability, the propellant samples are subjected to a simulated aging process at a raised temperature, at the end of which the gaseous and

condensed products of decomposition are determined quantitatively. Storage of the propellant samples at increased temperature takes place in a pressure container in order to prevent the evaporation of water from the propellant mixture.

It is the aim of our work to propose processes for testing chemical stability in which long-term storage of liquid propellants in a closed system can be carried out under conditions not presenting any risk.

### 3.1.1 Storage in glass ampoules

One simple method for testing the chemical stability of liquid propellants is storage in glass ampoules at a raised temperature until the ampoules burst. We found the best ampoules to be those commercially available and manufactured on an industrial scale holding a volume of 5 ml and having walls 0.6 mm thick. At isothermic storage, these containers withstand an internal pressure of 10 bar. Decomposition of the monergols takes place in sealed containers under a rapid rise in pressure, whereby values of over 30 bar can be built up during a few days. However, bursting of the ampoules already occurs at 10 bar. Due to this rapid building up of pressure, the glass ampoules burst with an identical test solution at short time intervals and thus supply significant measurement results. Each individual measurement value is obtained as an average parameter over 5 parallel tests. Although it would have been more desirable for statistical reasons, we nevertheless had to abandon employing a larger number of parallel reference samples due to economic considerations. Only when a number of "exceptional cases" occurred did we have to repeat the measurement series. Under these conditions, the times up to bursting of the ampoules (in one test series) varied by 20 % at the most. In spite of

the disadvantages evident (faultless filling, a possibility of partial decomposition when sealing the ampoules by melting the glass), the validity of the values obtained is very high. For example, the bursting time of the ampoules is shortened from 86 to 21 days when LP 1846 with impurities of 10 ppm iron ions is used in place of the pure substance.

The monergols are filled into the containers in quantities of 0.700 g. When filling, great care must be taken to obtain the highest degree of purity, as traces of impurities at 1 - 2 ppm are already capable of initiating a premature decomposition. After sealing (by melting the glass), the ampoules are stored in a heating block thermostat at 90 °C.

We have one possibility of testing by determining the time it takes before an ampoule bursts. Assessment of the bursting time takes place at intervals of 24 hours. The period of time up to decomposition of the samples stored under isochoric and isothermic conditions is a measure for the chemical stability of liquid propellants.

Table 2 provides a summary of the results of measurements obtained according to this method. The influence of impurities at concentrations of 10 ppm on the decomposition times of monergols NOS-365 and LP 1846 are compared.

The duration of decomposition of the monergols examined differs considerably. The life terms of LP 1846 is approximately one third longer than that of NOS 365. When one compares the relative decomposition times of both contaminated monergols (the decomposition times of the non-contaminated samples were fixed from the beginning at 100 %), a good agreement of the specific influence of the added metal ions on the life terms of the two propellant

samples is found. The chemical stability of the two monergols decreases in the following order of metal ions added as impurities: nickel, cobalt, copper, iron. Molybdenum and tungsten salts show a slight effect on stability similar to that of nickel ions.

A further simple possibility for testing monergols in glass ampoules consists of storing them in heating block thermostats for predetermined periods of time (e.g. 5, 10 and 15 days), whereby the tests are discontinued prior to destruction of the containers and the samples subjected to thermic loading finally analyzed.

The ampoules are cooled in liquid nitrogen, opened and their components analyzed. By means of this method, the degree of decomposition can be determined as dependent on storage duration.

### 3.1.2 Storage in glass containers with pressure sensors

Measurement of the pressure rise using sensors is an elegant method for testing the stability of these monergols. The rise in pressure due to the gases produced by decomposition - as depending on storage duration - is a measure for the chemical stability of the products involved. As a method, pressure measurement provides the advantage that a change of the test substance over time can be monitored directly. The tests can be discontinued when a certain internal pressure is exceeded.

Fig. 1 gives detailed information on the measuring equipment. The glass containers with an exterior diameter of 14 mm, a length of 100 mm and a wall thickness of 1.5 mm are equipped with a threaded sealing cap. They are capable of withstanding an interior pressure of 30 bar. A cali-

brated pressure sensor made of stainless steel of the type 17-4 PH (Mat. No. 1.4542) Armco Steel Corp. is fitted in a hole drilled through the sealing cap with a foil-type strain-gauge full bridge for C 0.07 %, Mn 1.0 %, P 0.04 %, S 0.03 %, Si 1.0 %, Cr 15,5 - 17.5 %, Ni 3-5 %, Cu 3-5 % and Nb + Ta 0.15-0.45 %. The pressure is recorded via a UPM 60 multisite measurement unit manufactured by Messrs. Hottinger Baldwin Meßtechnik.

This universally applicable unit is designed to accommodate a maximum of 60 measurement leads and is equipped with integrated measuring amplifiers, HD transducers and a microprocessor, measurement value processing system, a 24 computer interface and paper strip printer.

### 3.1.3 Storage in glass ampoules with strain-gauges

According to the test arrangement described in Section 3.1.2 above, the pressure sensor is located directly over the test solution and is subjected to the temperature and the acid atmosphere of the monergol during the entire storage period. It is here a prerequisite that the material of the pressure sensor be insensitive to humidity and gases produced by decomposition to avoid the release of ions which would in turn accelerate decomposition of the propellant tested. In order to exclude these disturbing factors during the test process, a material is used for the pressure sensors which is similar to that for electrodes in the manufacture of HAN by the electrolytic reduction of nitric acid. At the present time, the purest HAN products with very low concentrations of metal ions can be obtained through the electrolytic reduction of  $\text{HNO}_3$  with precious metal electrodes (Au, Pt).

As an alternative to measurement of the pressure rise with the sensor fitted in the test container, the pressure can also be measured with the aid of strain gauges adhered to the outside wall of a thin-walled glass ampoule ( $< 0.5$ ). The advantage of this test procedure is found in the fact that the strain-gauge pressure sensor does not come into contact with the liquid tested, thus excluding the possibility of results being influenced by metal ions from the sensors used.

On account of the interior pressure generated by the decomposition gases, the wall of the molten-sealed glass ampoule are subjected to a transverse and longitudinal expansion.

Test measurements in half-bridge circuits with temperature compensation were carried out in which an active strip was adhered to the molten-sealed glass container and a compensation strip onto an empty, open test container. This method can be employed for evaluation with the UPM 60 multi-site measurement unit internally for 10 measurement points in each case. Further sample tests in half-bridge circuitry without temperature compensation were carried out in which a fixed resistance was used in place of the compensation strain gauge. The measurements showed that - in both test arrangements - the strain gauge sensitive to longitudinal force showed a low rate of expansion but that sensitive to transverse forces recorded relatively high expansion values of  $12.5 \mu\text{m}/\text{bar}$ . Fig. 2 shows the pressure curves. These testing methods provide us with statements on the decomposition and influences on the stability of monopropellants containing HAN. They show changes during the reaction period with high sensitivity. Disturbances from metal ions released from the material of the pressure sensor used are here excluded.



4. The influence of pressure sensor materials on the life terms of liquid propellant samples

As a disadvantage in the storage of monopropellants in glass ampoules with strain gauges attached to them by adhesion, we found that each glass ampoule had to be calibrated separately for the test temperature coming into consideration each time.

We therefore tried to monitor the progression of pressure changes in the liquid propellant samples during long-term storage with pressure sensors. This had the prerequisite that work material components from the pressure sensors and the sealing elements exert no influence on the life terms of the sample propellants.

Preliminary trials with various pressure sensors had shown that - after the influence of NOS-365 at 90 °C (194 °F) over a period of several months - the surfaces of the sensors manifested corrosion phenomena. Apart from water vapors, hydroxylamine and nitric acid also occur in the containers in the gaseous phase during the storage of monergols containing HAN at raised temperature. The presence of these substances was found in the distillate of LP 1846 via potentiometric titration.

To examine the influence of materials intended for use in the pressure sensors manufactured by Messrs. Burster Präzisionsmeßtechnik, samples of sensors with different materials as alternatives (see Table 3 for compositions). alloy components and coating materials were stored in glass ampoules with LP 1846 at 90 °C. At the same time, two types of weapon steel for nitroaliphatic-based monergols were tested (Table 4). The time was measured up to bursting of the ampoules.

The samples of sensor materials were stored either in the form of powders or filings at different quantities. The influencing factors of surface area and surface passivity could not be determined in this test. As some of the samples became dissolved in the liquid propellant surrounding them, it was only possible to make qualitative statements using the storage test with metal work materials.

We observed that Fe, Co and Ni already entered into solution in cold LP 1846, yielding a green and pink color respectively. As with ammoniac - hydroxylamine tends to form metal complexes, thus encouraging the dissolving of metals in propellants containing HAN. This should also exert an influence on the corrosion resistance of all parts of weapon systems coming into contact with the liquid (pump, supply line and loading system). Furthermore, the chemical stability of liquid propellants deteriorates due to contact with unsuited metals: this is why return flow of the monergols contaminated in this way back to their containers must be avoided at all events.

Protection of that part of the pressure sensor coming into contact with the product (Fig. 1) by means of Teflon coating to avoid contamination of the monergol during long-term storage was here also taken into consideration. However, coating of the pressure sensor with Teflon presents difficulties from a processing technology point of view. The use of Teflon layers also restricts the measuring accuracy of pressure sensors as Teflon foil is only gastight at thicknesses greater than 4.5 mm.

Long-term storage tests with metal materials in glass ampoules (Tab. 4) have shown that only gold causes no reduction in storage duration. From this observation, we considered the use of gold-coated pressure sensors. The supplier was therefore commissioned to coat the pressure

sensors made of the basic material 17/4 PH galvanically with a gold layer 10  $\mu\text{m}$  thick according to a special process. This guarantees a pore-tight coating of the membrane and the sensor fitted with such a membrane. The measurement accuracy of the sensor is in no way restricted by gold coating of this type.

At the present time we are still working on what materials are most suitable for sealing of the pressure containers with circular washers.

5. Annex (Figures and Tables)

Fig. 1: Test arrangement for pressure measurements on liquid propellants

Fig. 2: Measurement of longitudinal and transverse expansion as dependent on internal pressure using strain gauges on glass ampoules

Tab. 1: Analysis values for monergols containing HAN

Tab. 2: Comparison of the influence of metal ions (10 ppm) on the storability of NDS-365 and LP 1846 at 90 °C.  
Storage period in days and relative storage period in %.

Tab. 3: The composition of stainless steels

Tab. 4: The influence of metals on the chemical stability of LP 1846

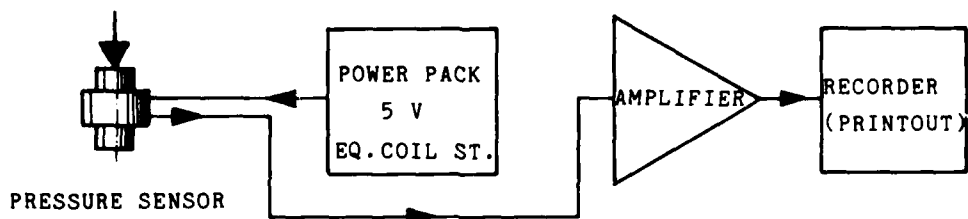

TRANSDUCER MODEL No. G./13992 - 02

SERIAL No. 120966 0 - 20 BAR

SUPPLIER: BURSTER PRECISION MEASUREMENT EQUIPMENT, FRG  
(BURSTER PRÄZISIONSMESSTECHNIK)

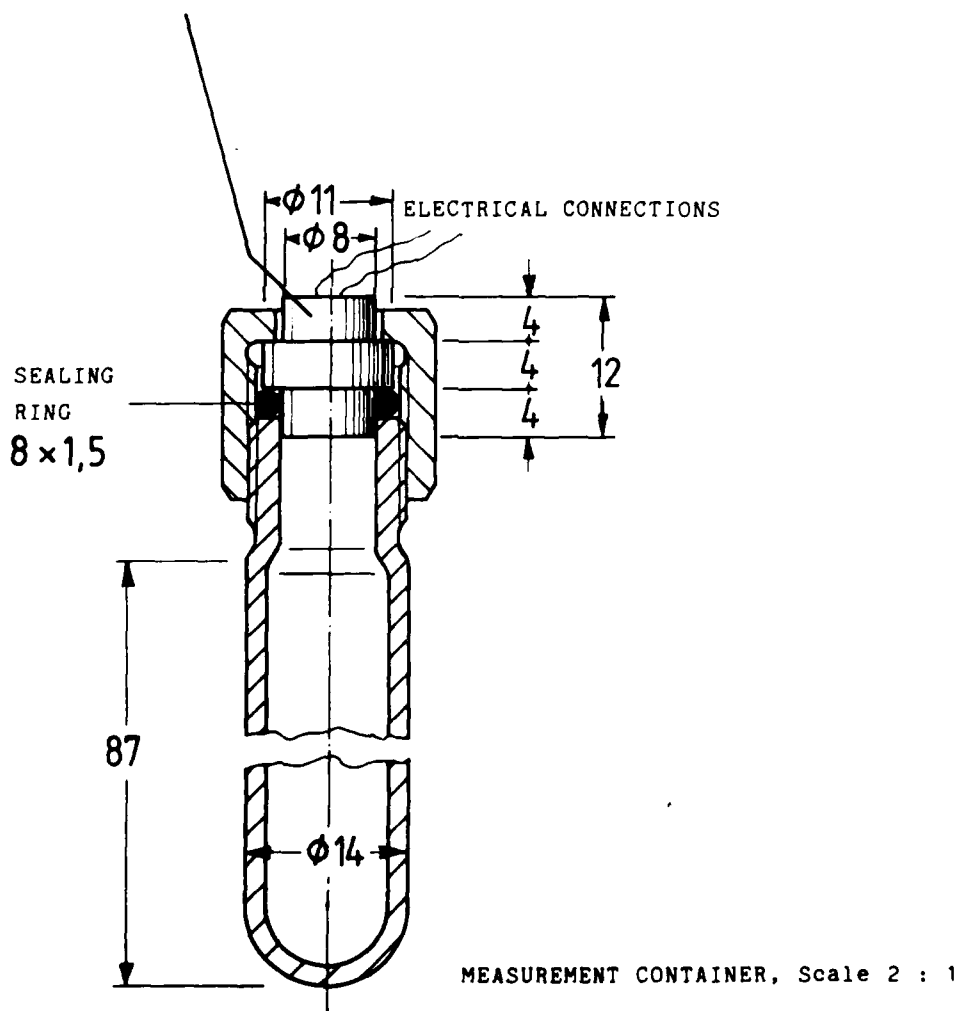

**Fig. 1:** TEST ARRANGEMENT FOR PRESSURE MEASUREMENTS ON LIQUID PROPELLANTS (all dimensions are metric)

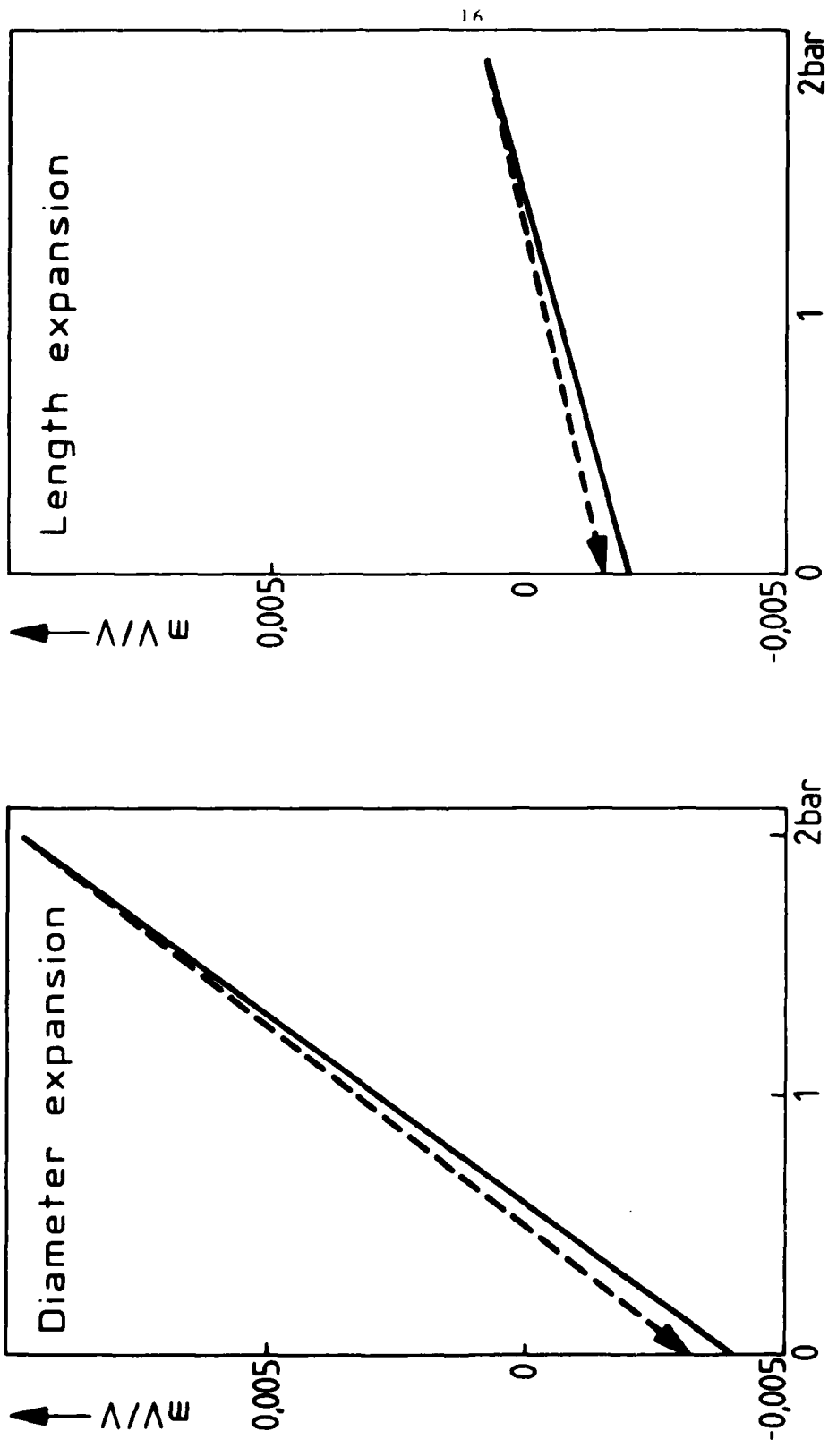

Fig. 2: Measurement of longitudinal and transverse expansion as dependent on internal pressure using strain gauges on glass ampoules

LP-Type		LP 1845	LP 1845	NOS-365	LP 1846
HAN-producer or LOT-No.		BASF	THIOKOL	LOT H 240	LOT 49-1
HAN [wt-%]		60,04	63,01	58,58	61,43
TEAN [wt-%]		18,37	20,14	-	18,54
IPAN [wt-%]		-	-	17,73	-
H <sub>2</sub> O [wt-%]		19,49	16,07	21,88	19,50
NH <sub>4</sub> NO <sub>3</sub> [wt-%]		2,10	0,47	1,56	0,53
HNO <sub>3</sub> [wt-%]		0,00	0,31	0,25	0,00
HNO <sub>3</sub> [moles/l]		0,00	0,05	0,04	0,00
pH (diluted 1:1)		2,741	0,974	1,413	1,705
Density 25 °C [g/cm <sup>3</sup> ]		1,462	1,466	1,385	1,445
AAS in ppm	Detection limit				
Cu	0,1	0,02	0,02	0,04	0,02
Zn	0,2	-	-	-	-
V	1,7	<1,9	<2,0	<1,0	<2,0
Cr	0,2	0,33	0,02	0,10	0,13
Mo	0,6	<2,0	<2,0	<2,0	<2,0
W	11,0	<11	<11	<11	<11
Mn	0,05	0,00	0,01	0,05	0,03
Fe	0,1	0,90	0,10	1,1	0,10
Co	-	-	-	-	-
Ni	0,1	0,37	0,37	0,27	0,26
Sn	1,0	-	-	-	-
Na	0,1	-	-	-	-
Ca	-	-	-	-	-

Table 1: Analysis values for monergols containing HAN

Substance	Decomposition Time in Ampoules			
	NOS-365 (LOT H 240)		LP 1846 (LOT 49-1)	
	in days	in %	in days	in %
-	63,3	100	86,6	100
Fe (NO <sub>3</sub> ) <sub>3</sub> ·9 H <sub>2</sub> O	18,5	29,2	21,1	24
Ni (NO <sub>3</sub> ) <sub>2</sub> ·6 H <sub>2</sub> O	54,1	85,5	65,3	75,4
Co (NO <sub>3</sub> ) <sub>2</sub> ·6 H <sub>2</sub> O	41,0	64,8	56,6	65,4
Cu (NO <sub>3</sub> ) <sub>2</sub> ·3 H <sub>2</sub> O	27,5	43,4	41,6	48,0
Na <sub>2</sub> WO <sub>4</sub> ·2 H <sub>2</sub> O	53,5	84,5	58,3	67,3
(NH <sub>4</sub> ) <sub>6</sub> Mo <sub>7</sub> O <sub>24</sub> ·4H <sub>2</sub> O	53,8	84,6	65,4	75,4

Table 2: Comparison of the influence of metal ions (10 ppm) on the storability of NOS-365 and LP 1846 at 90 °C.  
Storage period in days and relative storage period in %



Material	17/4 PH	V 2A	V 4A	30 Cr Ni Mo 8V	35 Ni Cr Mo V 125
Material No.	1.4542	1.4541	1.4571	1.6580	1.2760
C	< 0,07	≤ 0,06	0,06	0,26-0,33	0,35
Si	< 1	≤ 1	≤ 1	0,25	0,2
Mn	< 1,00	≤ 2	≤ 2	0,45	0,5
P	< 0,04			0,035	
S	< 0,03				
Cr	15,5-17,5	17-19	16,5-18,5	2,0	1,4
Mo	-		2-2,5	0,4	0,3
Ni	3,00-5,00	9-11,5	10,5-13,5	2,0	4,0
Cu	3,00-5,00				
Nb + Ta	0,15-0,45				
Ti		0,3	0,3		

Table 3: The composition of stainless steels

Substance	Decomposition Time [d]	Relativ Storage Period [%]
-	68,6	100
17/4 PH	15,7	22,9
V 2 A	1,8	2,6
V 4 A	50,4	73,5
30 Cr Ni Mo 8 V	0,8	1,1
35 Ni Cr Mo V 125	0,5	0,7
Platinum	56,7	82,7
Tantalum	47,5	69,2
Gold	69,5	101,3
Nickel	56,8	82,8
Cobalt	55,6	81,0
Tin	45	65,6
Copper	1,6	2,3
Titanium	42	61,2
Iron	1	1,5
Silicon	57	83,1
Chromium	23,4	34,1
Tungsten	34,1	49,7
Molybdenum	47,8	69,7
Rhenium	1,5	2,2

Table 4: The influence of metals on the chemical stability of  
LP 1846

END

DATE

~~FILED~~ MED

4 88