

NO-A190 374

LOW COST ELECTROMAGNETIC SHIELDING USING DRYHALL  
COMPOSITES: RESULTS OF R. (U) CONSTRUCTION ENGINEERING  
RESEARCH LAB (ARMY) CHAMPAIGN IL P F WILLIAMS ET AL.

1/1

UNCLASSIFIED

OCT 87 CERL-TR-M-88/02

F/G 11/4

ML

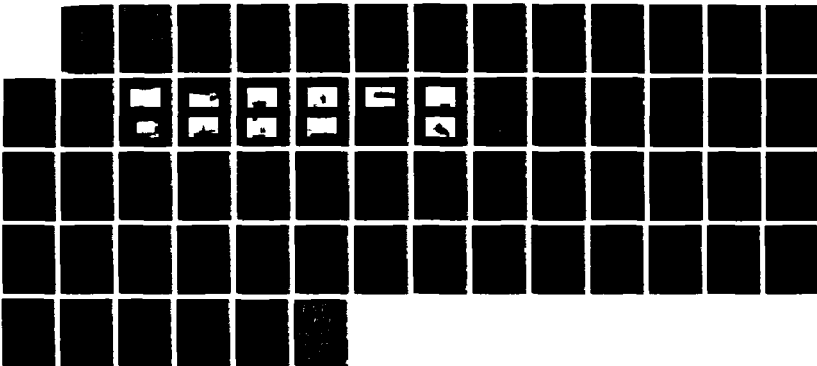

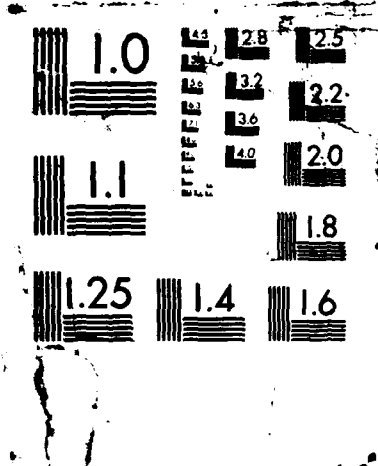



**US Army Corps  
of Engineers**  
Construction Engineering  
Research Laboratory

USA-CERL TECHNICAL REPORT M-88/02  
October 1987

**AD-A190 374**

**DTIC FILE COPY**

# Low Cost Electromagnetic Shielding Using Drywall Composites: Results of RFI Testing of Shielding Effectiveness

by  
Peter F. Williams  
Kevin K. Heyen  
Ray G. McCormack

Because of developments in electronics technology, the need for electromagnetic shielding has increased. To reduce the cost of this shielding, new materials are needed. The U.S. Army Corps of Engineers, Fort Worth District (FWD), and the U.S. Army Construction Engineering Research Laboratory (USA-CERL) have developed composite materials which use standard, construction grade, aluminum foil-backed gypsum board in combination with either a metal mesh or lead foil. Special seams for these composites have been designed by U.S. Gypsum Company.

USA-CERL evaluated the adequacy of each material and seam design by using radio frequency antennas and receivers to measure its shielding effectiveness when mounted in the wall of a shielded room. These evaluations showed that the composite panels met the specified requirement of 60 decibels (dB) of shielding. The composites were also shown to be adequate for most commercial security applications. However, the addition of a seam decreased shielding by as much as 10 dB.

Approved for public release; distribution is unlimited.

**DTIC  
ELECTE**  
S JAN 19 1988 D  
H

**88 1 12 034**

REPORT DOCUMENTATION PAGE				Form Approved OMB No 0704 0188 Exp Date Jun 30 1986	
1a REPORT SECURITY CLASSIFICATION <b>UNCLASSIFIED</b>		1b RESTRICTIVE MARKINGS			
2a SECURITY CLASSIFICATION AUTHORITY		3 DISTRIBUTION / AVAILABILITY OF REPORT Approved for public release; distribution is unlimited.			
2b DECLASSIFICATION / DOWNGRADING SCHEDULE					
4 PERFORMING ORGANIZATION REPORT NUMBER(S)  USA-CERL TR M-88/02		5 MONITORING ORGANIZATION REPORT NUMBER(S)			
6a NAME OF PERFORMING ORGANIZATION U.S. Army Construction Engr Research Laboratory		6b OFFICE SYMBOL (if applicable)	7a NAME OF MONITORING ORGANIZATION		
6c ADDRESS (City, State, and ZIP Code) P.O. Box 4005 Champaign, IL 61820-1305		7b ADDRESS (City, State, and ZIP Code)			
8a NAME OF FUNDING / SPONSORING ORGANIZATION USACE FWD		8b OFFICE SYMBOL (if applicable) CESWF-ED-DA	9 PROCUREMENT INSTRUMENT IDENTIFICATION NUMBER FAD E87860014, dated November 1985		
8c ADDRESS (City, State, and ZIP Code) P.O. Box 17300 Fort Worth, TX 76102-0300		10 SOURCE OF FUNDING NUMBERS			
		PROGRAM ELEMENT NO	PROJECT NO	TASK NO	WORK UNIT ACCESSION NO
11 TITLE (Include Security Classification) Low Cost Electromagnetic Shielding Using Drywall Composites: Results of RFI Testing of Shielding Effectiveness (Unclassified)					
12 PERSONAL AUTHOR(S) Williams, Peter F.; Heyen, Kevin K.; McCormack, Ray G.					
13a TYPE OF REPORT Final		13b TIME COVERED FROM _____ TO _____		14 DATE OF REPORT (Year, Month, Day) October 1987	15 PAGE COUNT 58
16 SUPPLEMENTARY NOTATION Copies are available from the National Technical Information Service Springfield, VA 22161					
17 COSATI CODES		18 SUBJECT TERMS (Continue on reverse if necessary and identify by block number)			
FIELD	GROUP	SUB-GROUP			
09	07		electromagnetic shielding		
			drywall		
			gypsum board		
19 ABSTRACT (Continue on reverse if necessary and identify by block number)					
<p>Because of developments in electronics technology, the need for electromagnetic shielding has increased. To reduce the cost of this shielding, new materials are needed. The U.S. Army Corps of Engineers, Fort Worth District (FWD), and the U.S. Army Construction Engineering Research Laboratory (USA-CERL) have developed composite materials which use standard, construction grade, aluminum foil-backed gypsum board in combination with either a metal mesh or lead foil. Special seams for these composites have been designed by U.S. Gypsum Company.</p> <p>USA-CERL evaluated the adequacy of each material and seam design by using radio frequency antennas and receivers to measure its shielding effectiveness when mounted in the wall of a shielded room. These evaluations showed that the composite panels met the</p>					
(Cont'd)					
20 DISTRIBUTION / AVAILABILITY OF ABSTRACT <input type="checkbox"/> UNCLASSIFIED-UNLIMITED <input checked="" type="checkbox"/> SAME AS RPT <input type="checkbox"/> DTIC USERS			21 ABSTRACT SECURITY CLASSIFICATION <b>UNCLASSIFIED</b>		
22a NAME OF RESPONSIBLE INDIVIDUAL Jane Andrew		22b TELEPHONE (Include Area Code) (217) 352-6511 (Ext 388)		22c OFFICE SYMBOL CECER-INT	

UNCLASSIFIED

BLOCK 19 (Cont'd)

specified requirement of 60 decibels (dB) of shielding. The composites were also shown to be adequate for most communications security applications. However, the addition of a seam decreased shielding by as much as 10 dB.



UNCLASSIFIED

## FOREWORD

This investigation was conducted for the U.S. Army Corps of Engineers, Fort Worth District (FWD), under Funding Authorization Document E87860014, dated November 1985. The work was performed by the Engineering and Materials (EM) Division of the U.S. Army Construction Engineering Research Laboratory (USA-CERL). Mr. Allen Fine, Architectural Section, Fort Worth District (CESWF-ED-DA) originated the concept of using foil-backed gypsum board in combination with metal mesh as a shielding material. Mr. J. Uriel Quinones is the Chief of the Architectural Section and COL A. J. Genetti, Jr., is the Commander of Fort Worth District. The technical editor was Jane Andrew, USA-CERL Information Management Office.

Appreciation is expressed to the U.S. Gypsum Company for their assistance in supplying some of the materials for testing, along with technical information on those materials.

COL Norman C. Hintz is the Commander and Director of USA-CERL, Dr. L. R. Shaffer is the Technical Director, and Dr. R. Quattrone is the Chief of the EM Division.



Accession For	
NTIS GRA&I	<input checked="" type="checkbox"/>
DTIC TAB	<input type="checkbox"/>
Unannounced	<input type="checkbox"/>
Justification	
By _____	
Distribution/	
Availability Codes	
AVAIL AND STATE	
Dist _____	

A-1

## CONTENTS

	Page
DD FORM 1473	1
FOREWORD	3
LIST OF FIGURES AND TABLES	5
1 INTRODUCTION .....	9
Background	
Objectives	
Approach	
Scope	
Mode of Technology Transfer	
2 TEST PROCEDURE .....	11
Test Facility	
Test Samples	
Seam Designs	
Instrumentation and Setup	
Measurement Techniques	
3 TEST RESULTS .....	27
4 DISCUSSION OF TEST RESULTS .....	28
5 CONCLUSIONS AND RECOMMENDATIONS .....	30
Conclusions	
Recommendations	
APPENDIX A: Data Tables and Graphs	31
APPENDIX B: Calculation of Theoretical Shielding Effectiveness	55
APPENDIX C: Symbols and Abbreviations	58
DISTRIBUTION	

## FIGURES

Number		Page
1	Outside of CERL Test Aperture	15
2	Inside of CERL Test Aperture	15
3	Two Layers of Double Mesh Gaskets on Test Aperture	16
4	Aluminum-Backed Sheetrock Test Panel	16
5	Bronze Mesh Test Panel	17
6	Copper Mesh Test Panel	17
7	Lead Foil Test Panel	18
8	Bronze Mesh Test Panel With Tack Solder Every 6 in. on Each Edge	18
9	Metal Drywall Stud Showing Screw Spacing	19
10	Seam Design #2 or #3: Wooden Stud Inside Mesh	20
11	Seam Design #2 or #3: Metal Drywall Stud	20
12	Diagram of Seam Design #1	21
13	Diagram of Seam Design #2 and #3	21
14	Shielding Effectiveness Measurement Setups	24
15	Correction Factor Scale	26
A1	Shielding Effectiveness Vs. Log of Frequency for 0.00035 in. Aluminum-Backed Sheetrock	33
A2	Shielding Effectiveness Vs. Log of Frequency for 18 by 18 Bronze Mesh	35
A3	Shielding Effectiveness Vs. Log of Frequency for 18 by 18 Copper Mesh	37
A4	Shielding Effectiveness Vs. Log of Frequency for 0.002 in. Lead Foil	39
A5	Shielding Effectiveness Vs. Log of Frequency for Bronze Mesh Composite	41
A6	Shielding Effectiveness Vs. Log of Frequency for Copper Mesh Composite	43



## FIGURES (Cont'd)

Number		Page
A7	Shielding Effectiveness Vs. Log of Frequency for Lead Foil Composite	45
A8	Shielding Effectiveness Vs. Log of Frequency for Bronze Mesh Composite: Seam Design #1	46
A9	Shielding Effectiveness Vs. Log of Frequency for Bronze Mesh Composite: Seam Design #2	49
A10	Shielding Effectiveness Vs. Log of Frequency for Bronze Mesh Composite: Seam Design #3	51
A11	Shielding Effectiveness Vs. Log of Frequency for 0.00035 in. Aluminum Foil--Theory	52
A12	Shielding Effectiveness Vs. Log of Frequency for 0.00125 in. Aluminum Foil--Theory	53
A13	Shielding Effectiveness Vs. Log of Frequency for 0.00035 in. Aluminum Foil--Theory, for 0.00125 in. Aluminum Foil--Theory, and for 0.00035 in. Aluminum Foil--Data	54

## TABLES

1	Seam Designs	19
2	MIL-STD-285 Setups	22
3	IEEE 299 Setups	22
4	USA-CERL Setups	22
5	Test Equipment	23
6	Test Frequencies	26
A1	Maximum Dynamic Ranges for Each Test Setup	31
A2	Data for 0.00035 in. Aluminum-Backed Sheetrock	32
A3	Data for 18 by 18 Bronze Mesh	34
A4	Data for 18 by 18 Copper Mesh	36
A5	Data for 0.002 in. Lead Foil	38
A6	Data for Bronze Mesh Composite	40

**TABLES (Cont'd)**

<b>Number</b>		<b>Page</b>
A7	Data for Copper Mesh Composite	42
A8	Data for Lead Foil Composite	44
A9	Data for Bronze Mesh Composite: Seam Design #1	47
A10	Data for Bronze Mesh Composite: Seam Design #2	48
A11	Data for Bronze Mesh Composite: Seam Design #3	50

# **LOW COST ELECTROMAGNETIC SHIELDING USING DRYWALL COMPOSITES: RESULTS OF RFI TESTING OF SHIELDING EFFECTIVENESS**

## **1 INTRODUCTION**

### **Background**

Several trends have created a need for more effective electromagnetic shielding of Army electrical and electronic equipment. Aside from sheer complexity, this equipment is becoming more sensitive to electromagnetic interference (EMI), especially when very large scale integration (VLSI) semiconductors are used. This sensitivity poses a problem, given the critical roles such equipment plays: controlling large and small weapons systems, gathering intelligence, monitoring and controlling energy use, and assisting command and control, among many others. Furthermore, the quantity of classified information continues to increase, placing greater demands on electromagnetic security.

Obviously, shielding is extremely important, but it can be costly. Typically, such shielding represents a substantial percentage of the cost of facilities which house electronic equipment. For that reason, electromagnetic shielding designers and researchers are continuously seeking methods, materials, and designs to reduce shielding costs.

One innovative solution--using standard, aluminum foil-backed drywall along with metal mesh--was developed at the Fort Worth District (FWD) of the U. S. Army Corps of Engineers. FWD needed to evaluate the proposed designs, but since the district does not have a laboratory test capability, the U.S. Army Construction Engineering Research Laboratory (USA-CERL) was asked to perform laboratory experiments to evaluate them. In addition, several designs for shielding seams in these composites were devised by U.S. Gypsum Company. These also needed to be tested.

### **Objectives**

The objectives of this evaluation were to determine whether the proposed composite shielding materials would provide 60 decibels (dB) of shielding, and to evaluate the proposed designs for joining panels of the composite materials.

### **Approach**

Panels of the test materials were mounted in an aperture of a shielded room at USA-CERL. The room is shielded against radio-frequency interference (RFI) up to 120 dB. Test procedures specified in Military Standard (MIL-STD) 285<sup>1</sup> and the Institute of

---

<sup>1</sup>Military Standard 285, *Attenuation Measurements for Enclosure, Electromagnetic Shielding, for Electronic Test Purposes, Method of* (25 June 1956).

Electrical and Electronic Engineers (IEEE) Proposed Standard Procedures 299<sup>2</sup> (with some modifications) were used to determine the shielding effectiveness (SE) of the various panels. The standard procedures were modified slightly to allow for more modern equipment and for testing at more frequencies. Composite panels were made by pressing two panel types together in the panel test fixture of the shielded room. Seam designs were implemented in the center of the test panels, and more shielding tests were performed. The tests were analyzed manually but were graphed using a personal computer. The shielding tests were demonstrated at USA-CERL for representatives of the gypsum board manufacturer.

### **Scope**

The researchers restricted their evaluation to the performance of test panels under radio frequency continuous wave (RFCW) tests. Walls or rooms were not tested, and no transient effects were measured. The evaluation did not address the question of whether the materials would withstand the rigors of construction and the passing of time.

### **Mode of Technology Transfer**

It is recommended that the results of this research be incorporated into Army Technical Manual (TM) 5-855-5, *Nuclear Electromagnetic Pulse Protection* (Department of the Army, 15 February 1974).

---

<sup>2</sup>Institute of Electrical and Electronic Engineers Proposed Standard Procedures 299, *Trial-Use Recommended Practice for Measurement of Shielding Effectiveness of High-Performance Shielding Enclosures* (Institute of Electrical and Electronics Engineers, Inc., 1969).

## 2 TEST PROCEDURE

### Test Facility

The shielding effectiveness tests were conducted by mounting the test samples in a standard USA-CERL test aperture, located in a 120 dB shielded enclosure (an 11-gauge steel box with welded seams and a 3-1/2 by 7 ft\* shielded entry door). Outside, the aperture's dimensions are 4-1/2 by 2-1/2 ft (Figure 1),\*\* while the inside measures 4 ft 1 in. by 2 ft 1 in. (Figure 2). Figure 3 shows the two layers of double mesh gaskets which surround the test aperture. All of the test samples were cut to fit the aperture, so they had dimensions 4-1/2 by 2-1/2 ft. The two sides of the test panels were electrically connected by means of 3M conductive copper foil tape (3M #1245). This conductive tape was folded in half so that the adhesive was inside. It was then folded over the edges of the panel. Thus, the foil made electrical contact with both sides of the panel and with the aperture along all four edges.

### Test Samples

The materials to be evaluated were tested both separately and as composites. Each composite started with commercial grade drywall\*\*\* (also called plasterboard or gyp board) which had a sheet of aluminum foil affixed to one side. There were two thicknesses of aluminum used with the drywall: 0.00035 in. and 0.00125 in. When testing began, the manufacturer supplied only the drywall with the thinner foil. After learning that this drywall could be used for EMI/RFI Shielding, the thicker foil type was supplied. This thicker foil was used only for the copper composite. (In standard construction practice the aluminum serves as a moisture barrier.) Then one of three other materials--lead foil, bronze mesh, or copper mesh--was bonded onto the drywall side with commercial grade glue. The following are the seven samples that were tested.

1. Aluminum-Backed Sheetrock (alone)--1/2 in. Sheetrock with 0.00035 in. aluminum foil (Figure 4).
2. 18 by 18 Bronze Mesh--18 hole/in. bronze wire mesh with wire 0.010 in. thick (Figure 5).
3. 18 by 18 Copper Mesh--18 hole/in. copper wire mesh with wire 0.017 in. thick (Figure 6).
4. Lead Foil--two pieces of lead foil 1-1/3 ft by 4-1/2 ft by 0.002 in. glued to 1/4 in. masonite (Figure 7). The lead foil overlapped 2 in. in the center. This seam was sealed with 2 in. wide conductive copper electrical tape (3M #1245).
5. Bronze Mesh Composite--the above Sheetrock (0.00035 in. of aluminum) and the above 18 by 18 bronze mesh (Figures 4 and 5, aluminum and mesh sides respectively).
6. Copper Mesh Composite--Sheetrock with 0.00125 in. of aluminum and the above 18 by 18 copper mesh (Figures 4 and 6).

\*1 in. = 0.0254 m; 1 ft = 0.3048 m.

\*\*Figures and tables are at the end of the chapter.

\*\*\*The specific brand of drywall used was Sheetrock,<sup>®</sup> which is a registered name of U.S. Gypsum Company.

7. Lead Foil Composite--Sheetrock with 0.00125 in. of aluminum and the above lead foil (Figures 4 and 7).

### Seam Designs

No building can be constructed without joints or seams, but joints can cause buildings to become "leaky" due to changes in the impedance across joints and seams. Among other things, this makes the equipment inside them vulnerable to EMI. Therefore, in addition to the composite materials, three seam designs were tested.

The three designs have several elements in common. They were all made using the bronze mesh composite. The designs begin with a test panel that has been cut in half. Aluminum electrical tape on the aluminum side of the drywall provides electrical contact across the cut. Contact on the mesh side is achieved by providing a 6 in. overlap in the mesh, which is then tack soldered every 6 in. along both edges (Figure 8). The mesh is also stapled down. Finally, the seam is solidly fastened by sandwiching the halves of drywall between a metal stud and a 2 by 1 in. piece of lumber, then screwing them together (Figure 9).

The three designs differ in the spacing of screws, type of tape, placement of the wood, and placement of staples, as given in Table 1. Figures 10 and 11 show the mesh and aluminum sides (respectively) for design #2. Figure 12 is a diagram of design #1, and Figure 13 shows designs #2 and #3 (which differ only in screw spacing).

### Instrumentation and Setup

The testing was performed by following procedures similar to those outlined in IEEE Standard 299 and MIL-STD-285; the modifications to those standards (made to take advantage of current technology) were as follows.

- A logarithmic spiral (conical) antenna replaced the dipole antenna.
- The transmission line connector went through the shelter instead of through the test material.
- Tests were made at more frequencies than outlined in the standards.
- IEEE 299 suggests that a low frequency loop test be done in the frequency range of 100 Hz to 200 kHz. At USA-CERL no tests were done in this frequency range.
- For the intermediate wave measurement test setup, IEEE 299 requires that the dipole antennas be 1.3 wavelengths from the shield. At USA-CERL the distance used was 36 in.
- The antenna-to-shield distances differed for the 400 MHz test. MIL-STD-285 requires, for the reference test, that the source antennas be 72 in. from the shield, with the receiving antenna 2 to 24 in. from the shield on the same side as the source. It requires the source antenna for the signal test to be at the same distance from the shield as for the reference test, with the receiving antenna at 2 in. from the shield on the opposite side. At USA-CERL, for the reference test, source and receiving antennas were separated by 2 m, instead of 72 in., plus shield thickness. For the signal test, each antenna was placed 1 m from the shield.

Tables 2 and 3 give the frequencies and equipment recommended in the standards, while Table 4 gives the setup used at USA-CERL. Finally, Table 5 lists all the equipment used for each of the four setups. This equipment was used for both reference and signal measurements. Figure 14 shows how the equipment was arranged for each test.

### Measurement Techniques

The key measurement in these tests was the signal level (in decibels) detected by the receiver with the test panel in place. By defining  $O_r$  as the reference power level detected by the receiver without the test panel in place, and  $S_r$  as the signal level detected by the receiver with the test panel in place, the SE can be expressed in decibels as:

$$SE \text{ (dB)} = O_r - S_r^* \quad [\text{Eq 1}]$$

This equation is derived from equations that would be used if voltage or power were being measured.

$$SE \text{ (dB)} = 20 \text{ Log}_{10} E_1/E_2 \quad [\text{Eq 2}]$$

or

$$SE \text{ (dB)} = 10 \text{ Log}_{10} P_1/P_2 \quad [\text{Eq 3}]$$

where  $E_1$  = voltage level detected by the receiver without test panel in place

$E_2$  = voltage level detected by the receiver with test panel in place

$P_1$  = power level detected by the receiver without test panel in place

$P_2$  = power level detected by the receiver with the test panel in place.

The SE measurements were obtained by conducting reference tests and panel tests. For each measurement, the reference signal was recorded, with the transmitting antenna radiating a continuous wave (CW) signal directly into the receiving antenna, as in Figure 14. (This signal is the maximum the receiver will register at a particular power level and antenna spacing.) Then, once a panel was in place in the shielded enclosure, a CW signal was transmitted through it and then detected by a field-intensity receiver and antenna tuned to the CW transmitter frequency. The number of test frequencies required by MIL-STD-285 or IEEE 299 was not sufficient to reveal trends in the data. Therefore, the samples were tested at several frequencies between 150 kHz to 10 GHz, and graphs were plotted to note the trends. The exact frequencies at which tests were conducted are listed in Table 6.

As a measure of the sensitivity of the equipment, the dynamic range was calculated at each test frequency for each setup. It was determined by subtracting the receiver

---

\*Symbols are also listed in Appendix C.

noise level (with no radiating signal) from the receiver signal (with the transmitting antenna radiating directly into the receiving antenna as shown in Figure 14).

$$\text{Dynamic Range} = S_{\text{reference}} - S_{\text{noise}} \quad [\text{Eq 4}]$$

Of all the reference signals at a frequency, the largest one was used to calculate the maximum dynamic range at that frequency. These maximum dynamic ranges are listed in Table A1. These measurements apply only for the equipment listed in Table 5, when arranged as in Figure 14. The SE measured for any particular frequency using the specific equipment will never exceed the value of the maximum dynamic range at that frequency. The actual shielding may be greater, but the equipment cannot measure it because of limitations on the output power of the transmitter, the sensitivity of the receiver, and the coupling losses and efficiency of the antennas.

Technically, the dynamic range is actually greater than shown because rms (root mean square) signals add as the square root of the sum of squares. Thus, the instrument indicates 1 dB above noise for a signal which is actually below noise. A correction factor can be used to calculate the precise dynamic ranges when the signal is less than 10 dB above noise. Figure 15 and Equation 5 can be used to make the correction. The top scale is the meter reading of the signal level plus the noise level. The top scale also represents the decibel increase in meter reading over the noise level when an input signal is applied to the EMC-25 receiver. The bottom scale is the amount in decibels to be subtracted from the total meter reading to find the actual signal level.

$$\text{Correction Factor (dB)} = 10 \log [1/(1 - 10^{-(r/10)})] \quad [\text{Eq 5}]$$

This equation was derived from the scale of Figure 15, where  $r$  is the meter reading above noise.



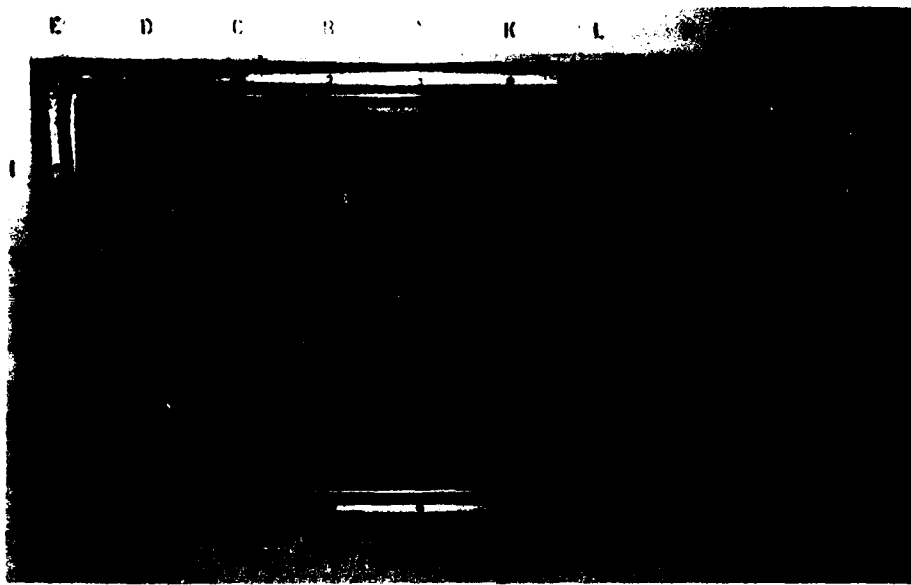

Figure 1. Outside of CERL test aperture.

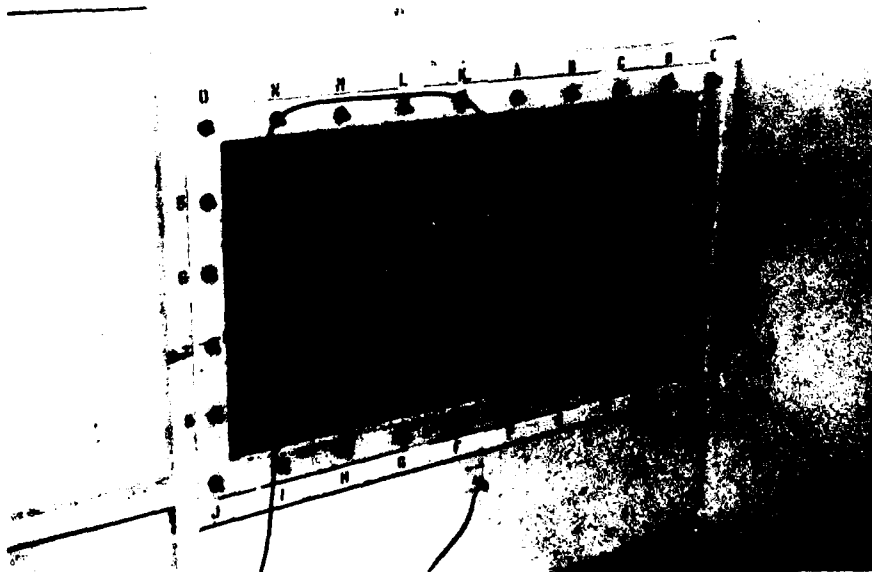
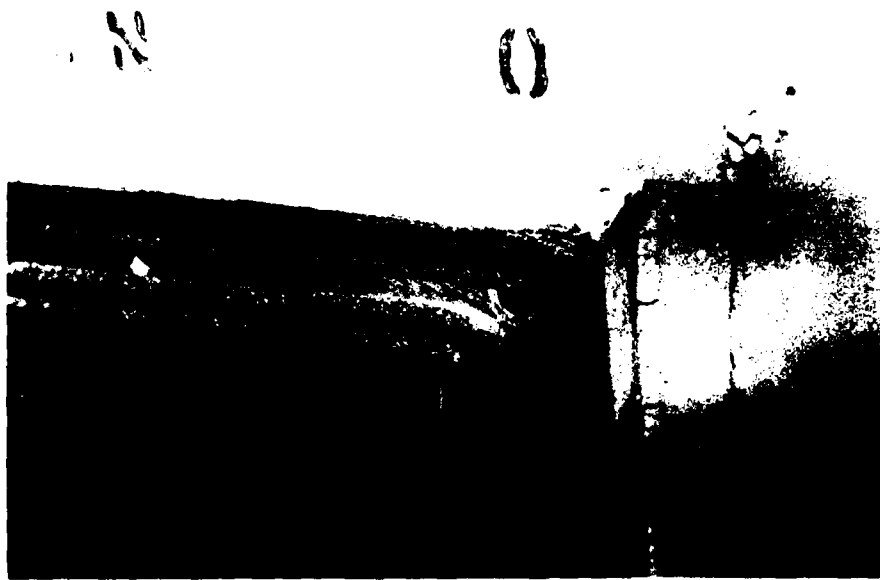

Figure 2. Inside of CERL test aperture.



**Figure 3. Two layers of double mesh gaskets on test aperture.**



**Figure 4. Aluminum-backed Sheetrock test panel.**



**Figure 5. Bronze mesh test panel.**

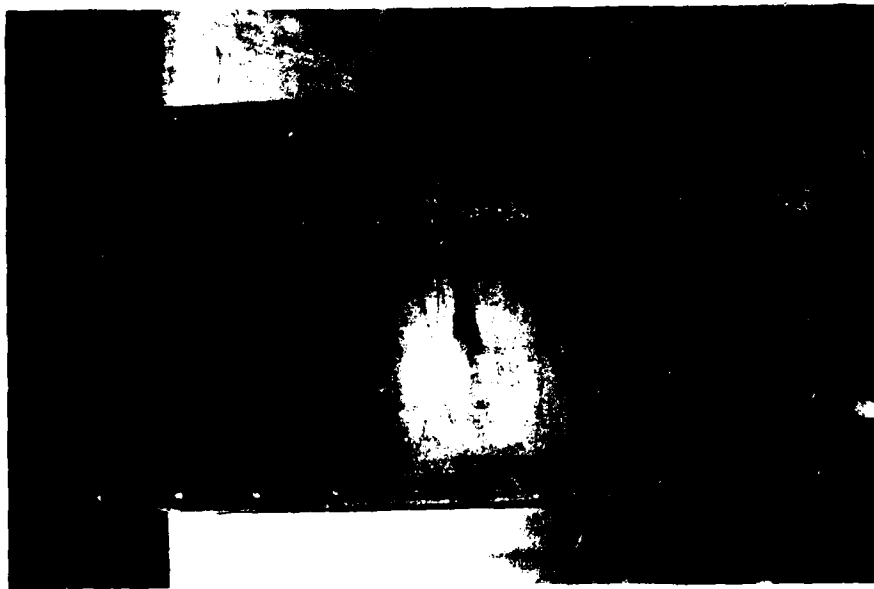

**Figure 6. Copper mesh test panel.**

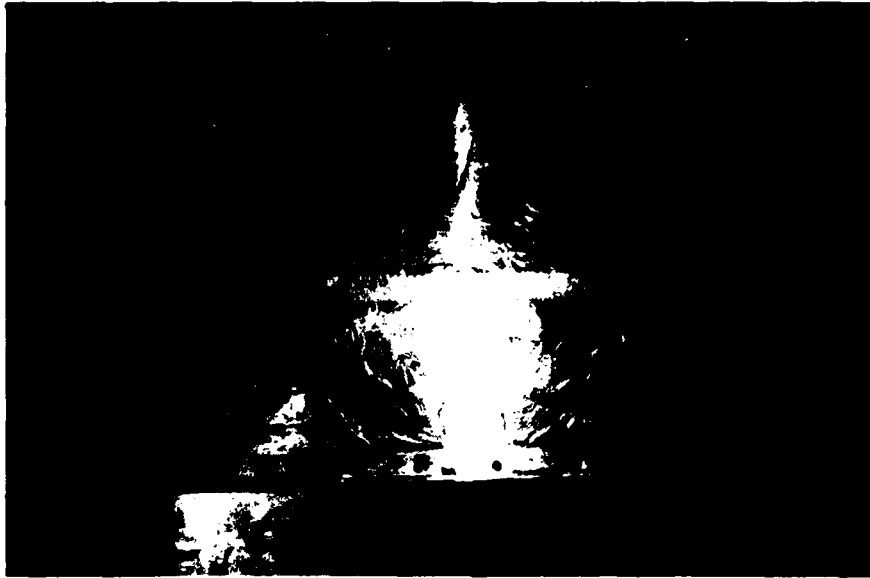

**Figure 7. Lead foil test panel.**

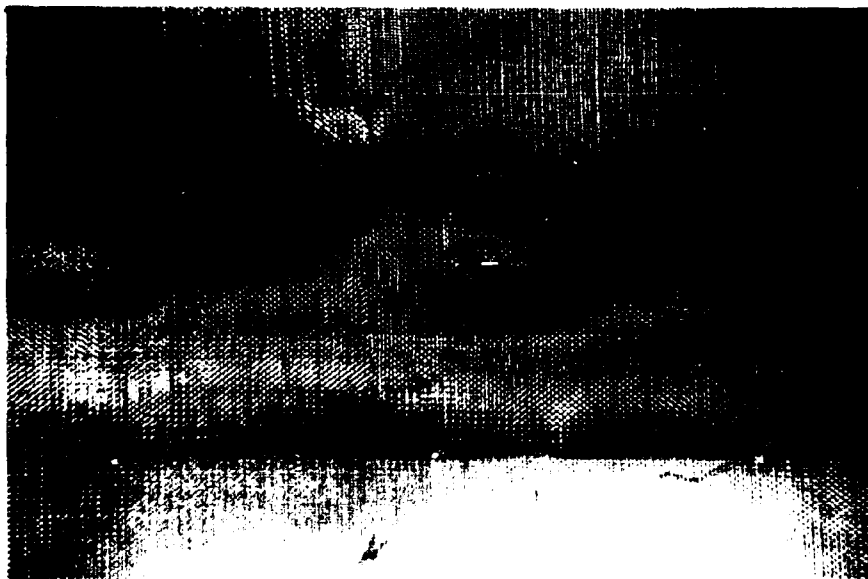

**Figure 8. Bronze mesh test panel with tack solder every 6 in. on each edge.**

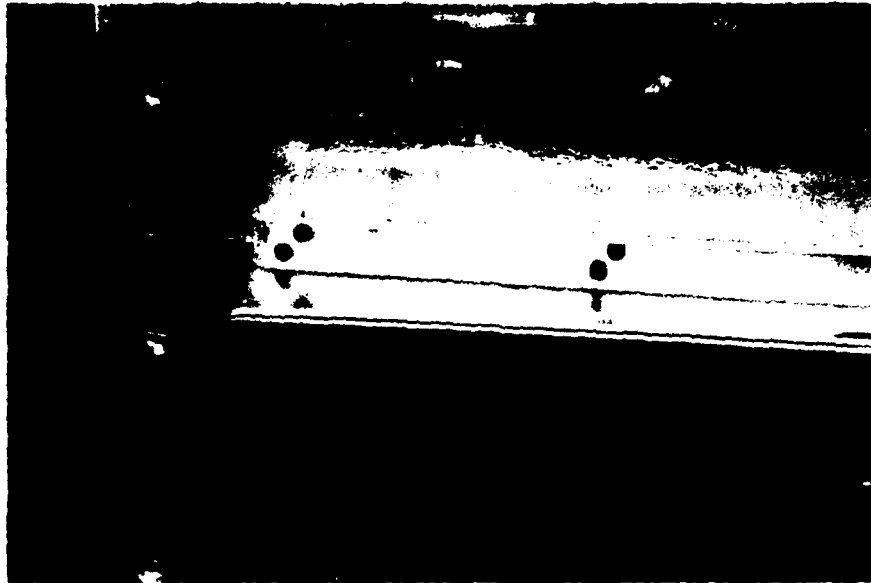

**Figure 9. Metal drywall stud showing screw spacing.**

**Table 1**

**Seam Designs**

<b>Seam Design</b>	<b>Screw Spacing (in.)</b>	<b>Tape Type</b>	<b>Wood Placement</b>	<b>Staple Placement</b>
1	12 - 18	3M #1170 (smooth aluminum)	On top of mesh	Into drywall
2	12 - 18	3M #1267 (embossed aluminum)	Under mesh	Into wood
3	6 - 9	3M #1267 (embossed aluminum)	Under mesh	Into wood



**Figure 10. Seam design #2 or #3: wooden stud inside mesh.**



**Figure 11. Seam design #2 or #3: metal drywall stud.**

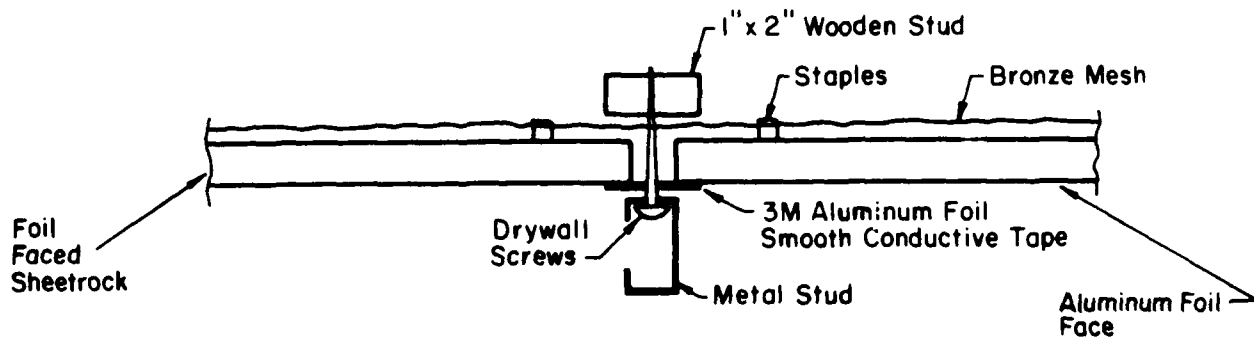

Figure 12. Diagram of seam design #1.

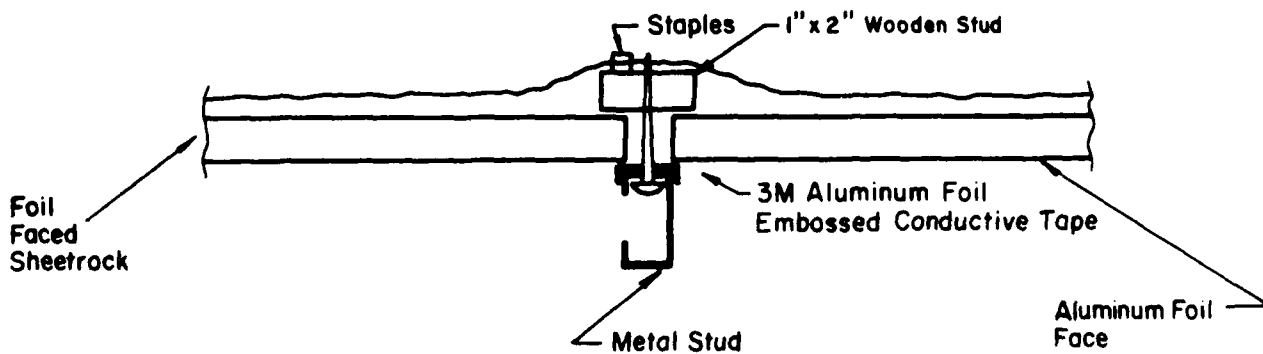

Figure 13. Diagram of seam design #2 and #3.

**Table 2****MIL-STD-285 Setups**

Field Type	Freq. Range	Antenna Type
Low impedance electric	150 - 200 kHz*	12 in. loop
High impedance electric	200 kHz	41 in. monopole (whip)
High impedance electric	1 MHz	41 in. monopole (whip)
High impedance electric	18 MHz	41 in. loop
Plane wave	400 MHz	balanced dipole

\*Test at one frequency in this range.

**Table 3****IEEE 299 Setups**

Field Type	Freq. Range	Antenna Type
Low impedance magnetic	100 Hz - 200 kHz	Large twisted lead
Low impedance magnetic	100 Hz - 20 MHz	12 in. loop
Intermediate Wave (UHF)	300 MHz - 1 GHz	balanced dipole
Plane Wave	1.7 - 12.4 GHz	x-band horn

**Table 4****USA-CERL Setups**

Field Type	Freq. Range	Antenna Type	Antenna Space
Low impedance magnetic	0.150 - 10 MHz	12 in. loop	24 in.
High impedance electric	0.150 - 500 MHz	41 in. whip	24 in.
Intermediate wave	200 - 1000 MHz	1 m log spiral	2 m
Plane wave	1 - 5 GHz	1 m log spiral	2 m
Plane wave	4 - 10 GHz	x-band horn	2 m



**Table 5**  
**Test Equipment**

<b>Setup</b>	<b>Frequency Range</b>	<b>Equipment</b>
12 in. loop	150 kHz - 10Mhz	1 CERL 12 in. copper loop HP signal generator model 8601 ENI power amp model 310L 2 velbon tripods VE-3 1 Empire 12 in. loop model LP105 Assorted cables and connectors 1 Electrometrics interference analyzer (receiver) model EMC-25 MKIII 1 Fairchild interference analyzer (receiver) model EMC-25
41 in. monopole	150 kHz - 500 MHz	2 Empire 41 in. whips model VA 10 HP signal generator model 8601 ENI power amp model 310L 2 velbon tripods VE-3 Ailtech power oscillator model 445 Ailtech power plug-in model 187 Ailtech power plug-in model 186 Assorted cables and connectors 1 Electrometrics interference analyzer (receiver) model EMC-25 MKIII 1 Fairchild interference analyzer (receiver) model EMC-25
1 M log spiral	200 MHz - 5 GHz	2 Eaton spiral antennas 93490-1 Ailtech power oscillator 445 Ailtech power plug-in 187 Ailtech power plug-in 186 Wiltron generator 6609A Wiltron generator 6637A Hughes TWT amp 1177H 2 velbon tripods VGB-3C Assorted cables and connectors 1 Electrometrics interference analyzer (receiver) model EMC-25 MKIII 1 AILTECH radio interference analyzer/receiver model NM-65T
X-band horn	4 GHz - 10 GHz	2 Waveline x-band antennas 499 2 HP adapter model J281A Wiltron generator 6637A Hughes TWT amp 1177H 2 velbon tripods VE-3 Assorted cables and connectors 1 AILTECH radio interference analyzer/receiver model NM-65T

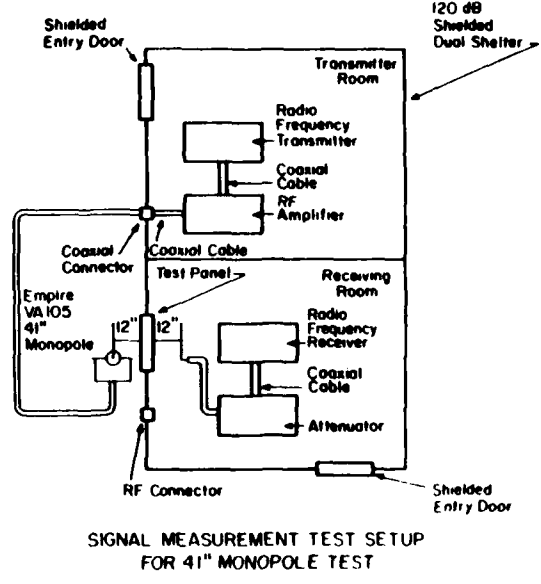
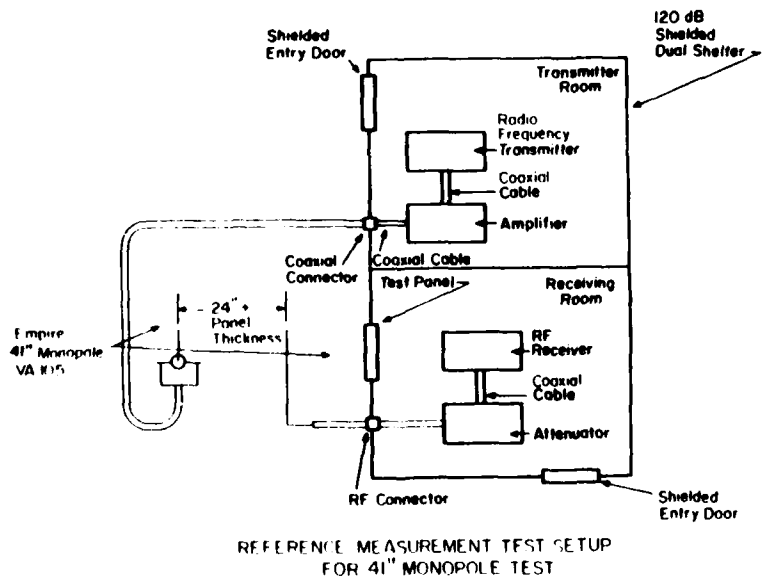
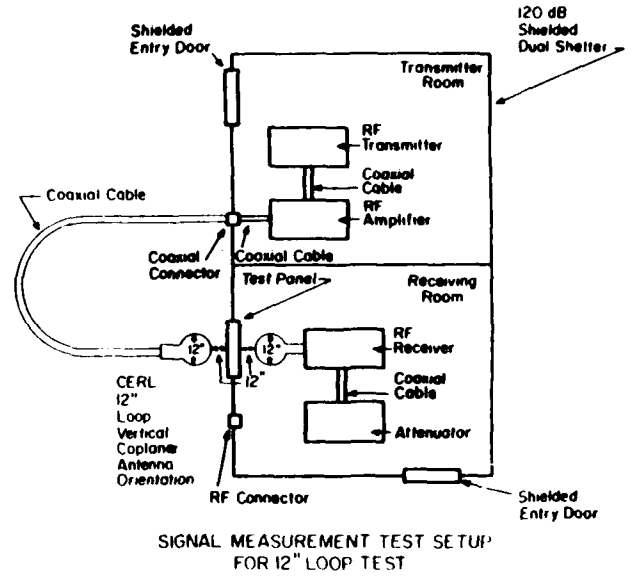
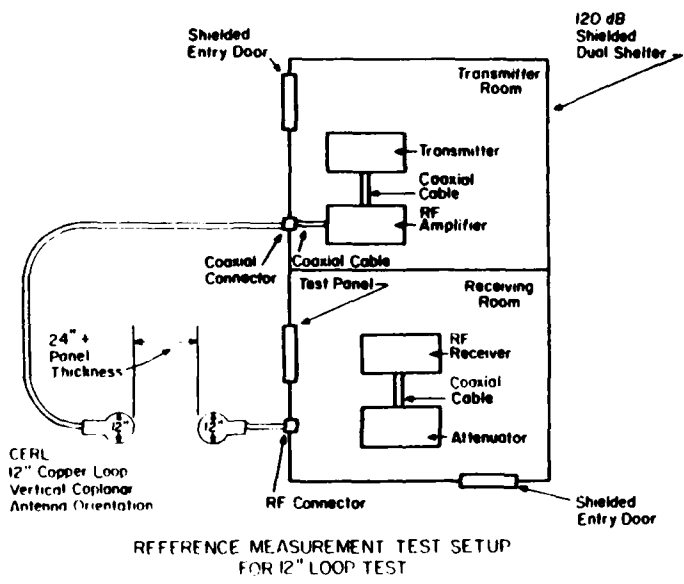
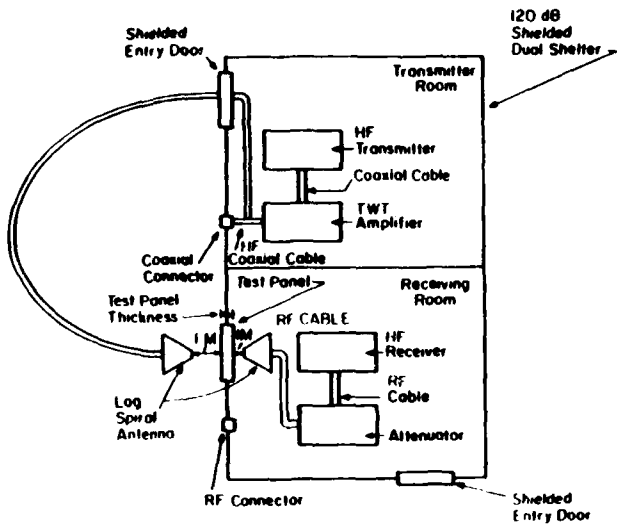
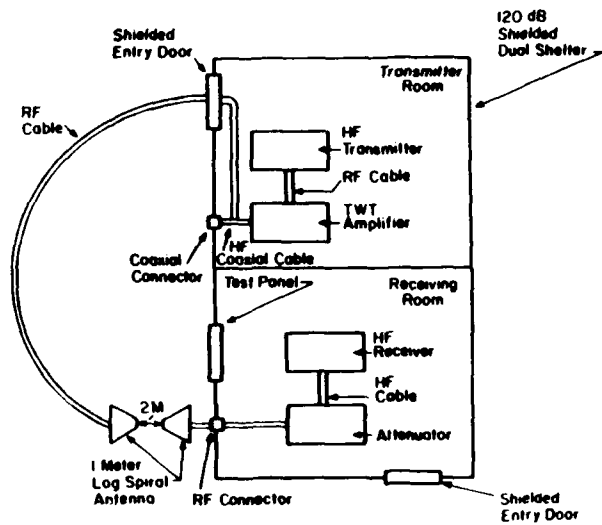

Figure 14. Shielding effectiveness measurement setups.



SIGNAL MEASUREMENT TEST SETUP  
FOR I METER LOG SPIRAL ANTENNA



REFERENCE MEASUREMENT TEST SETUP  
FOR I METER LOG SPIRAL ANTENNA

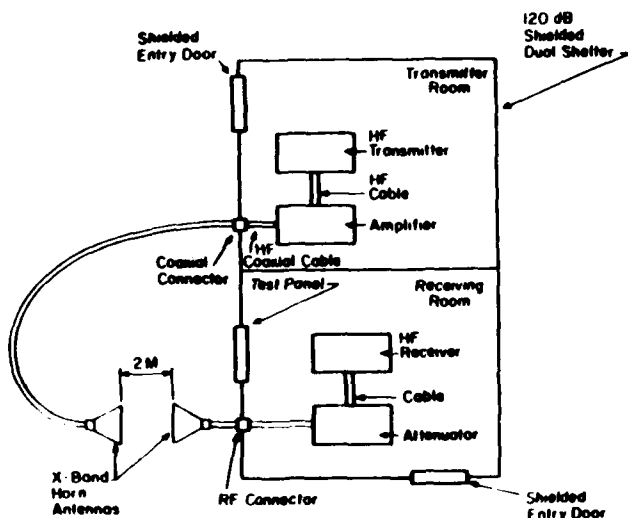

REFERENCE FOR MEASUREMENT TEST SETUP

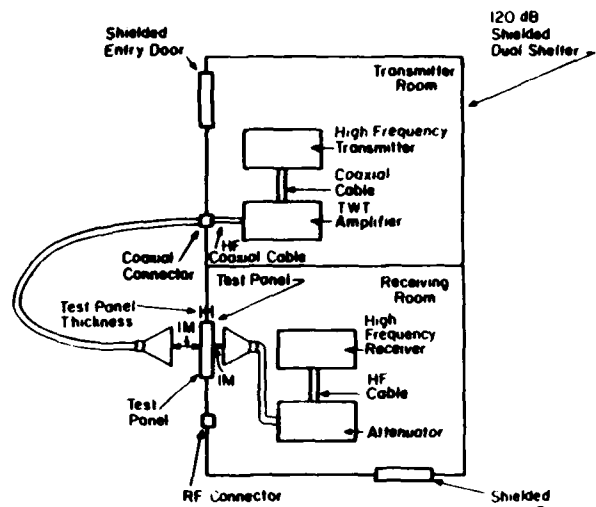

SIGNAL MEASUREMENT TEST SETUP  
FOR X-BAND HORN ANTENNA

Figure 14 (Cont'd).

**Table 6**  
**Test Frequencies**

<b>Magnetic Field (12 in. Loops)</b>	<b>Electric Field (41 in. Monopole)</b>	<b>Plane Wave (1 M Conical)</b>	<b>Plane Wave (X-Band Horn)</b>
150kHz	150kHz	200MHz	4000MHz
200kHz	200kHz	300MHz	5000MHz
300kHz	300kHz	400MHz	6000MHz
700kHz	700kHz	450MHz	7000MHz
1MHz	1MHz	600MHz	8000MHz
3MHz	3MHz	700MHz	9000MHz
10MHz	10MHz	800MHz	10000MHz
	15MHz	1000MHz	
	17MHz	2000MHz	
	18MHz	3000MHz	
	20MHz	4000MHz	
	25MHz	5000MHz	
	50MHz		
	200MHz		
	300MHz		
	350MHz		
	400MHz		
	500MHz		

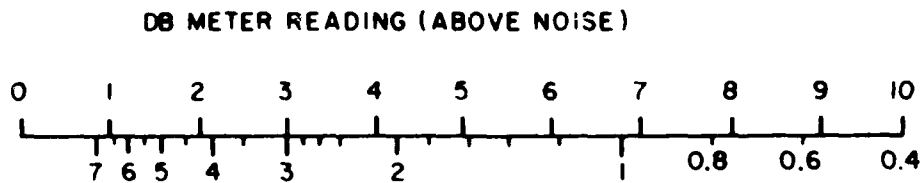

**CORRECTION FACTOR (SUBTRACT)**

**Figure 15.** Correction factor scale (from *Instruction Manual: Interference Analyzer Model EMC-25* [Electro-metrics, January 1978], p 3-1).

### 3 TEST RESULTS

The data are tabulated in Appendix A (Tables A2 through A11). The graphed data is also presented in Figures A1 through A10. In the tables, plus signs indicate readings which exceeded the dynamic range of the test equipment. This means that with the test panel mounted there was no detectable signal at these frequencies. That is, these measurements were close to or below the noise level of the receiver and for them, the recorded signal is actually the value of the noise level. These values for the dynamic ranges differ from those tabulated in Table A1 (maximum dynamic ranges) because of day-to-day changes in the receivers' sensitivity, in the power outputs of the transmitters, and in the human receiver operators.

For comparison, Appendix A includes theoretical plots for drywall faced with 0.00035 in. of aluminum foil (Figure A11) and with 0.00125 in. of aluminum foil (Figure A12). (For the equations and computer program used to generate these plots, see Appendix B.) Figure A13 combines these plots with another plot of the experimental data for the panel backed with 0.00035 in. foil. These graphs reveal that the measured data in the plane wave region does not agree with theory. This is probably due to leakage around or through the gaskets which surround the test aperture. The data for this material at all other frequencies agrees with theory. Theoretical data was calculated only for aluminum.

There are some differences between the theoretical assumptions used in the derivation of the theoretical shielding values and the way the shielding measurements were performed. These theoretical values are for an infinitely large sheet and an infinitely large antenna, and they are not affected by the aperture or the orientation of the antenna. In practice, a finite sheet and a finite antenna were used, and the values were affected by the aperture and the antenna's orientation.

#### 4 DISCUSSION OF TEST RESULTS

The procedures specified in MIL-STD-285 and IEEE Standard 299 provide for testing the entire area of material between the two antennas and not for any particular point or section on the test panel. The data presented in this report measure the SE of the entire test panel, including test aperture and gaskets. However, because of the antenna placement, the area directly between the two antennas has more effect on the SE measurements than the peripheral areas and gaskets do.

Many factors could cause the data to deviate from theoretical values.

- The cables (based on length) could resonate at certain frequencies.
- Metal objects in the vicinity of the test setup can change wave impedance.
- The shielded enclosure acts as a resonant cavity at frequencies which are multiples of 100 MHz.
- Rebar in the concrete floor could affect the wave impedance and thus change the tests.
- People walking around the test setup cause impedance changes in transmitted waves at higher frequencies.
- Using the 120 dB shielded enclosure affects the data by slightly increasing the SE of the materials.

In most security communication facilities the specific level of shielding demanded by security personnel is based on many different factors, such as distance to nearest unsecured area, the amount of emanations from the secured equipment, and the sensitivity of the information being transferred. When each of these factors is taken into account, the shielding in some cases only needs to be as little as 30 dB.<sup>3</sup>

From Figure A13 it can be seen that at many frequencies much of the real data for the 0.00035 in. aluminum foil agrees with the theoretical calculations. In the magnetic field region from 150 kHz to 10 MHz, three of six points graphed agree exactly, while the remaining three points are off by no more than 3 to 5 dB.

The materials being studied were tested alone and as part of composites, to see if they could meet the minimum of 60 dB of shielding at all frequencies. In the tables and figures, a plus sign by the number or over the data point indicates that the shielding at that frequency was greater than could be measured by the equipment used. In general, SE in the magnetic field region increases with sheer bulk of material, while in the plane wave region seams, gaps, and penetrations decrease shielding.

The materials were tested alone first. The 0.00035 in. aluminum sheeting alone is adequate except at low frequencies, in the magnetic field region (Figure A1). The bronze mesh tested alone fails the requirement at all frequencies (Figure A2), while the copper mesh and lead foil fail at high and low frequencies, respectively (Figures A3 and A4).

<sup>3</sup>Ray G. McCormack and Peter F. Williams, *Development, Design, Construction, and Testing of a Copper-Arc-Sprayed Shielded Enclosure*, Technical Report M-86/11/ADB106252 (USA-CERL, July 1986) p 28, Figure 13.

In the composite tests, the bronze and copper composites exceed the 60 dB minimum at all frequencies (Figures A5 and A6), but the lead foil composite fails at 150 kHz (Figure A7). The bronze composite barely exceeds 60 dB at the lower frequencies but provides much greater shielding at higher ones. Overall, the copper composite proved to be the best, providing shielding of 90 dB or greater across the test spectrum.

Three seam designs were tested, all using the bronze composite. The most effective design is #1, which has a wooden stud over the seam. Comparing design #1 (Figure A8) to design #2 (Figure A9), which has the wooden stud under the seam but has the same screw spacing, design #1 provides up to 22 dB more shielding in the plane wave region. Designs #2 and #3 differ only in that design #3 has more screws, and by comparing Figures A9 and A10 it can be seen that using more screws increases the shielding to nearly the level of design #1. So designs #1 and #3 are similar, but #1 provides as much as 10 dB more shielding in the electric field and plane wave regions, as shown in Figure A8 (#1) and A10 (#3). This is probably because the wooden stud improves the electrical contact along the mesh and thus improves the shielding. (The wooden studs initially were used only as anchors for the screws and as a connection to hold the drywall in the test aperture. In actual construction, these screws would be fastened directly to the metal stud through the aluminum-faced Sheetrock.)

In Figures A8 to A10, the shielding in the magnetic field region is approximately the same for each seam design. This is consistent with expectations because bulk is the critical factor in the magnetic region and the amount of material is the same in each design. However, in the plane wave region, differences in seams and other openings have the most effect.

As expected, the seams degrade the SE of the composite. Comparing the data for the whole bronze composite (Figure A5) to that for the composite with a seam (Figures A8 through A10), it can be seen that a seam decreases shielding by 10 to 13 dB in the 150 kHz to 3 MHz magnetic field region. In the bronze composite, including a seam, using design #1 drops the SE to around 52 dB. A seam in either of the other two composites would have the same effect. If design #1 were used with the lead composite, the maximum shielding would probably be 47 to 49 dB. If the same design were used with the copper composite, the SE would be 80 dB or greater.

## 5 CONCLUSIONS AND RECOMMENDATIONS

### Conclusions

Shielding levels of the composite panels are adequate for most communications security applications, and two of the composites exceed the minimum requirement of 60 dB set for this investigation. If the requirement is 50 dB or greater, the lead composite may not meet it because the composite's already low effectiveness will be further reduced by a seam. However, both the bronze mesh composite and the copper mesh composite will provide shielding up to 60 dB. If the shielding requirement is above 60 dB, only the copper mesh composite will meet it at all frequencies considered.

In addition, the following conclusions were reached after evaluating the three seam designs. A seam degrades the SE by as much as 10 dB in the low-frequency magnetic field region. However, spacing the screws more closely improves the SE. Overall, the best seam design was design #1, which had a 1 in. by 2 in. piece of lumber placed over the seam. Thus, with a seam, the maximum SE of each of the composites would probably be as follows: lead, 47 to 49 dB; bronze, 52 dB; and copper, 80 dB.

### Recommendations

It is difficult to make definitive statements about electromagnetic shielding because its uses vary, and the shielding requirements vary with the use. However, the following general recommendations are made.

- For seams, a 1 by 2 in. piece of standard lumber should be attached on top of each overlapping mesh seam. This forms a good electrical and mechanical connection, eliminating the need to tack solder every 6 in. on each edge. This method will not only increase the SE, but it will also save construction time and decrease the cost of the shelter.
- For maximum shielding, the copper mesh and the 0.00125 in. aluminum faced gypboard should be used, rather than the bronze mesh with the 0.00035 in. aluminum faced board. This will increase the cost, but the SE will increase by 10 to 30 dB.
- Construction applicability and construction costs should be determined for the composite designs.
- Long term aging tests should be performed in a field demonstration facility: the aluminum seams may oxidize and corrode, which will change the SE over time.

Aside from the question of adequate shielding levels, which this report addressed, the issue of low cost shielding raises several other questions that should be considered.

- Are these materials appropriate for an electromagnetic pulse (EMP) environment?
- What kind of quality assurance is there or will there be?
- What kind of maintenance is required to insure that these materials will continue to meet the requirements?



**APPENDIX A:**

**DATA TABLES AND GRAPHS**

**Table A1**

**Maximum Dynamic Ranges for Each Test Setup**

Freq. (MHz)	Ref. (dB)	Noise Level (dB)	Dynamic Range (dB)
-------------	-----------	------------------	--------------------

**12 in. Loop Test**

0.150	81	-29	110
0.200	80	-30	110
0.300	77	-30	107
0.700	73	-31	104
1.00	75	-30	105
3.00	71	-24	95
10.0	67	-25	92

**41 in. Monopole Test**

0.150	122	-29	151
0.200	111	-31	142
0.300	115	-30	145
0.700	118	-31	149
1.00	120	-30	150
3.00	121	-24	145
10.0	123	-25	148
15.0	126	-24	150
18.0	120	-24	144
20.0	113	-24	137
25.0	121	-24	145
50.0	103	-10	113
200.0	120	- 8	128
300.0	121	- 5	126
350.0	122	- 6	128
400.0	98	- 6	104
500.0	95	- 5	100

**1 M Log Spiral Test**

200.0	104	-11	115
300.0	126	- 9	135
400.0	123	- 7	130
450.0	120	- 7	127
600.0	105	-1	106
700.0	104	0	104
800.0	102	0	102
1000.0	105	0	105
2000.0	86	12	74
3000.0	88	13	75
4000.0	84	13	71
5000.0	82	13	79

**X-Band Horn Test**

4000.0	69	11	58
5000.0	122	11	111
6000.0	123	13	110
7000.0	122	13	109
8000.0	123	13	110
9000.0	116	13	103
10000.0	110	13	97

Table A2

Data for 0.00035 in. Aluminum-Backed Sheetrock

ALUMINUM COATED SHEETROCK  
 KEVIN HEYEN-TRANS, PETER WILLIAMS-REC., MARC MORRIS-TRANS.  
 9/30/85 10:30 - 13:00

FREQ(MHz)	REF dB	SIGNAL dB	SE dB
Magnetic Field (12 in. Loops)			
0.15	77.0	37.0	40.0
0.20	76.0	34.0	42.0
0.30	78.0	32.0	46.0
0.70	75.0	23.0	52.0
1.00	73.0	19.0	54.0
3.00	69.0	3.0	66.0
Electric Field (Monopole Antennas)			
0.15	107.0	-18.0	125.0 +
0.20	108.0	-15.0	123.0
0.30	113.0	-28.0	141.0
0.70	116.0	0.0	116.0
1.00	119.0	-9.0	128.0
3.00	121.0	-3.0	124.0
10.00	111.0	5.0	106.0
15.00	100.0	6.0	94.0
17.00	114.0	11.0	103.0
18.00	114.0	11.0	103.0
20.00	111.0	12.0	99.0
25.00	118.0	12.0	106.0
50.00	83.0	-10.0	93.0
200.00	87.0	-7.0	94.0
300.00	89.0	-7.0	96.0
350.00	88.0	-14.0	102.0
400.00	78.0	-16.0	94.0
500.00	69.0	-22.0	91.0
Plane Wave (Conical Antennas)			
200.00	87.0	-13.0	100.0
300.00	100.0	-6.0	106.0
400.00	99.0	-3.0	102.0
450.00	97.0	-7.0	104.0
600.00	95.0	-9.0	104.0
700.00	87.0	-15.0	102.0
800.00	86.0	-17.0	103.0
1000.00	84.0	-19.0	103.0
Plane Wave (Horn Antennas)			
5000.00	89.0	21.0	68.0 +
6000.00	87.0	18.0	69.0 +
7000.00	86.0	17.0	69.0 +
8000.00	85.0	15.0	70.0 +
9000.00	82.0	19.0	63.0 +
10000.00	82.0	21.0	61.0 +

+Exceeded dynamic range of test equipment.

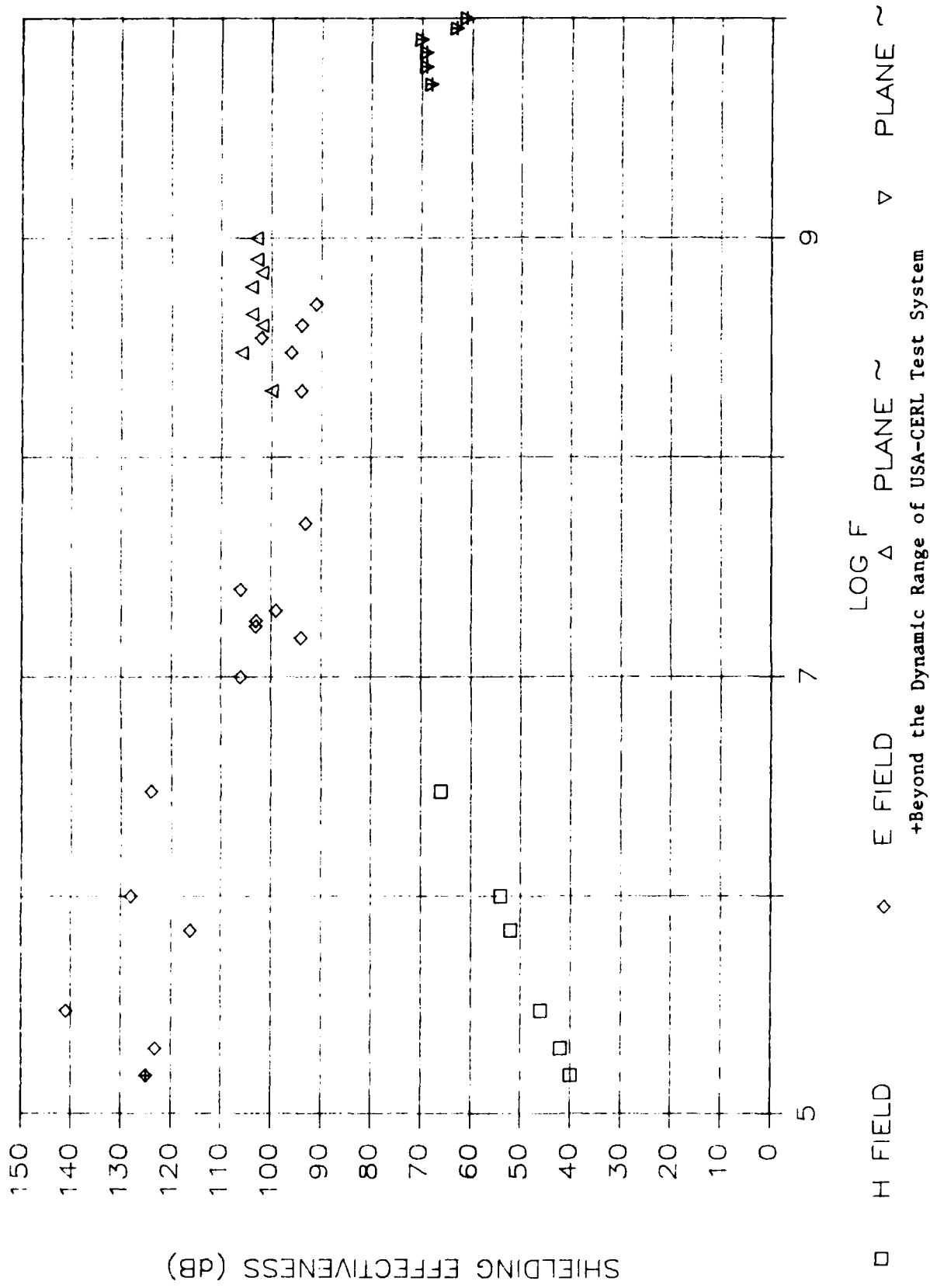

Figure A1. Shielding effectiveness vs. log of frequency for 0.00035 in. aluminum-backed Sheetrock.

Table A3

Data for 18 by 18 Bronze Mesh

HANOVER 18 BY 18 BRONZE MESH  
 KEVIN HEYEN-TRANS, PETER WILLIAMS-REC., MARC MORRIS-TRANS.  
 9/29/85 13:00 - 14:30

FREQ(MHz)	REF dB	SIGNAL dB	SE dB
Magnetic Field (12 in. Loops)			
0.15	83.0	38.0	45.0
0.20	81.0	34.0	47.0
0.30	80.0	31.0	49.0
0.70	73.0	22.0	57.0
1.00	77.0	20.0	57.0
3.00	70.0	12.0	58.0
Electric Field (Monopole Antennas)			
0.15	110.0	35.0	75.0
0.20	111.0	35.0	76.0
0.30	115.0	35.0	80.0
0.70	118.0	38.0	80.0
1.00	120.0	41.0	79.0
3.00	121.0	41.0	80.0
10.00	107.0	25.0	82.0
15.00	101.0	21.0	80.0
17.00	114.0	32.0	82.0
18.00	113.0	31.0	82.0
20.00	111.0	22.0	89.0
25.00	114.0	3.0	111.0
50.00	83.0	24.0	59.0
200.00	91.0	31.0	60.0
300.00	88.0	36.0	52.0
350.00	87.0	30.0	57.0
400.00	80.0	17.0	63.0
500.00	72.0	15.0	57.0
Plane Wave (Conical Antennas)			
200.00	90.0	27.0	63.0
300.00	101.0	40.0	61.0
400.00	100.0	44.0	56.0
450.00	98.0	44.0	54.0
600.00	98.0	44.0	54.0
700.00	93.0	42.0	51.0
800.00	91.0	39.0	52.0
1000.00	87.0	42.0	45.0
Plane Wave (Horn Antennas)			
5000.00	90.0	57.0	33.0
6000.00	88.0	55.0	33.0
7000.00	87.0	54.0	33.0
8000.00	85.0	51.0	34.0
9000.00	82.0	50.0	32.0
10000.00	80.0	48.0	32.0

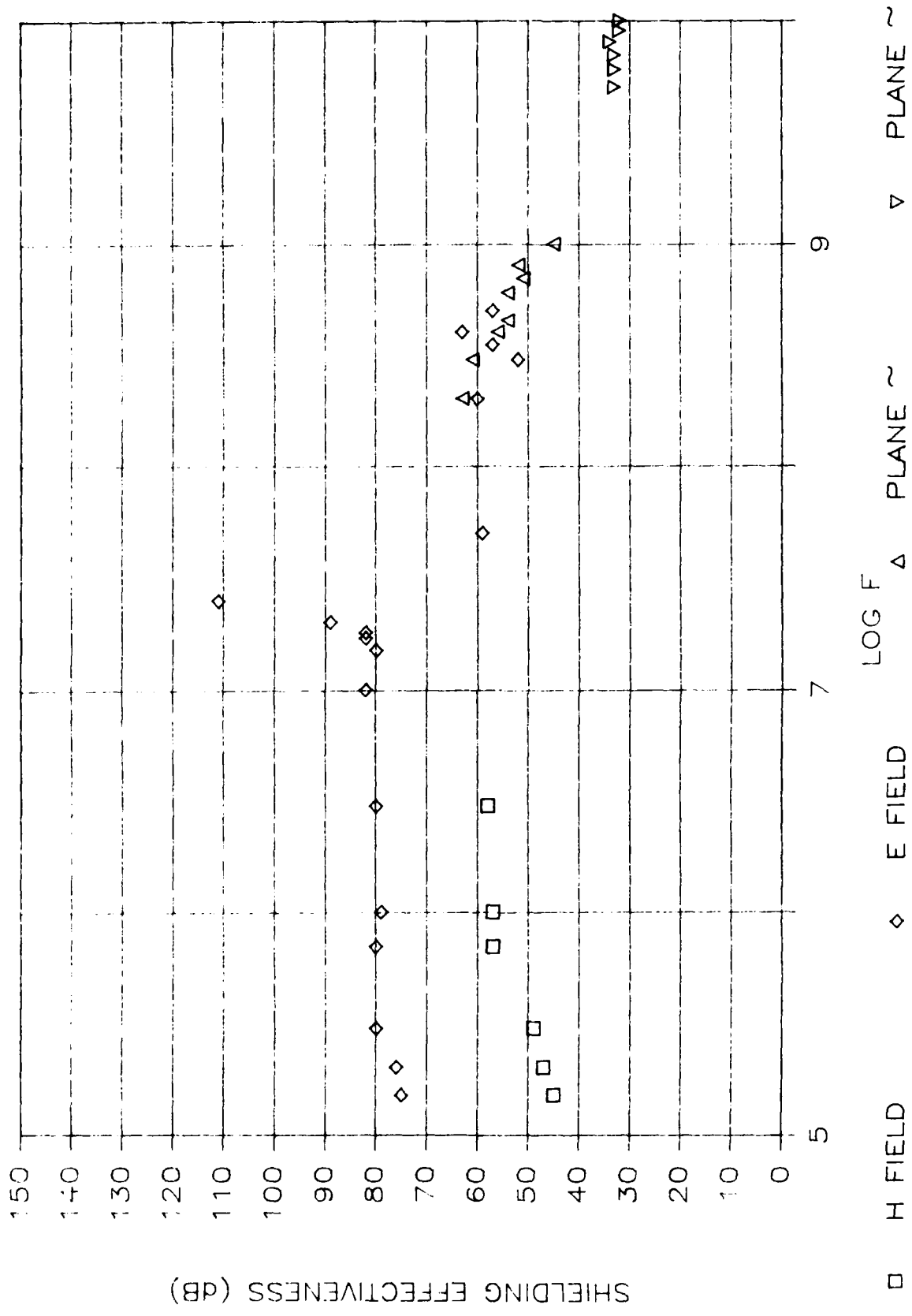

Figure A2. Shielding effectiveness vs. log of frequency for 18 by 18 bronze mesh.

Table A4

Data for 18 by 18 Copper Mesh

COPPER MESH  
 5/28/86 Peter Williams-Receive and Kevin Heyen-Trans.  
 9:45 - 14:45

FREQ(MHz)	REF dB	SIGNAL dB	SE dB
Coplanar Magnetic (12 in. Loops)			
0.15	64.0	-4.0	68.0
0.20	67.0	-3.0	70.0
0.30	65.0	-3.0	68.0
0.70	63.0	-5.0	68.0
1.00	61.0	-7.0	68.0
3.00	60.0	-12.0	72.0
10.00	50.0	-24.0	74.0
Electric Field (Monopole Antennas)			
0.15	113.0	17.0	96.0
0.20	110.0	15.0	95.0
0.30	110.0	15.0	95.0
0.70	111.0	17.0	94.0
1.00	118.0	20.0	98.0
3.00	118.0	23.0	95.0
10.00	123.0	9.0	114.0
15.00	114.0	13.0	101.0
17.00	114.0	8.0	106.0
18.00	114.0	8.0	106.0
20.00	112.0	4.0	108.0
25.00	121.0	0.0	121.0
50.00	96.0	23.0	73.0
200.00	103.0	36.0	67.0
300.00	106.0	40.0	66.0
350.00	105.0	37.0	68.0
400.00	98.0	29.0	69.0
500.00	90.0	42.0	48.0
Plane Wave (Conical Antennas)			
200.00	75.0	7.0	68.0
300.00	110.0	32.0	78.0
400.00	104.0	35.0	69.0
450.00	100.0	33.0	67.0
600.00	81.0	22.0	59.0
700.00	80.0	23.0	57.0
800.00	78.0	25.0	53.0
1000.00	76.0	26.0	50.0
1000.00	105.0	54.0	51.0
2000.00	86.0	42.0	44.0
3000.00	88.0	37.0	51.0
4000.00	84.0	45.0	39.0
5000.00	82.0	40.0	42.0
Plane Wave (Horn Antennas)			
4000.00	62.0	16.0	46.0
5000.00	108.0	61.0	47.0
6000.00	113.0	68.0	45.0
7000.00	111.0	77.0	34.0
8000.00	110.0	79.0	31.0
9000.00	107.0	73.0	34.0
10000.00	99.0	66.0	33.0

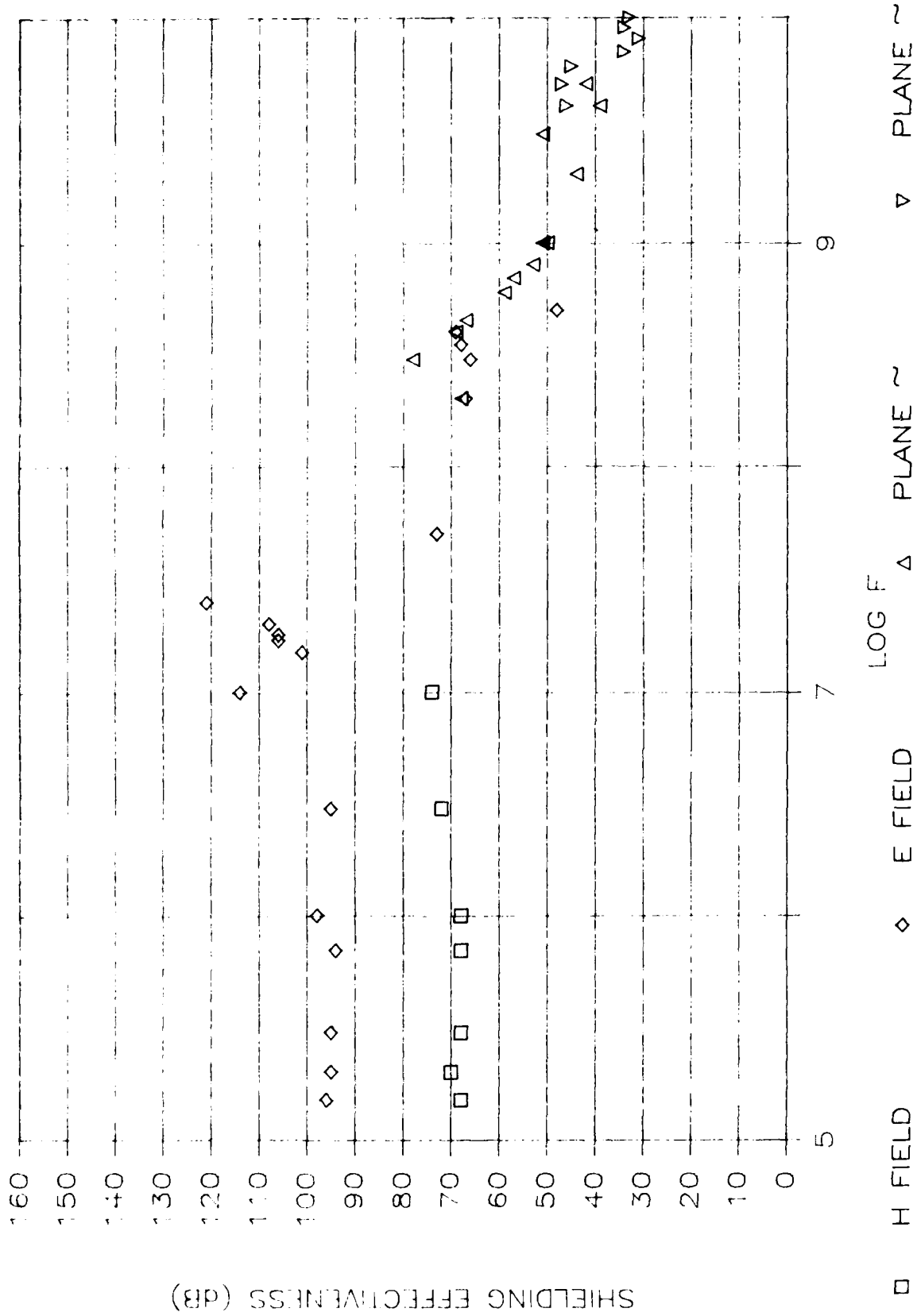

Figure A3. Shielding effectiveness vs. log of frequency for 18 by 18 copper mesh.

Table A5

Data for 0.002 in. Lead Foil

U.S. GYPSUM LEAD FOIL WITH 3M 2" COPPER FOIL TAPE SEAM  
 6/04/86 Peter Williams-Receive and Kevin Heyen-Trans.  
 10:26 - 16:45

FREQ(MHz)	REF dB	SIGNAL dB	SE dB
Coplanar Magnetic (12 in. Loops)			
0.15	71.0	51.0	20.0
0.20	70.0	48.0	22.0
0.30	73.0	47.0	26.0
0.70	71.0	39.0	32.0
1.00	69.0	33.0	36.0
3.00	65.0	20.0	45.0
10.00	61.0	5.0	56.0
Electric Field (Monopole Antennas)			
0.15	113.0	-25.0	138.0
0.20	110.0	-18.0	128.0
0.30	110.0	-19.0	129.0
0.70	111.0	-10.0	121.0
1.00	118.0	-5.0	123.0
3.00	118.0	9.0	109.0
10.00	123.0	5.0	118.0
15.00	114.0	19.0	95.0
17.00	114.0	23.0	91.0
18.00	114.0	23.0	91.0
20.00	112.0	22.0	90.0
25.00	121.0	27.0	94.0
50.00	96.0	23.0	73.0
200.00	103.0	29.0	74.0
300.00	106.0	15.0	91.0
350.00	105.0	24.0	81.0
400.00	98.0	21.0	77.0
500.00	90.0	14.0	76.0
Plane Wave (Conical Antennas)			
200.00	103.0	17.0	86.0
300.00	126.0	44.0	82.0
400.00	123.0	43.0	80.0
450.00	120.0	43.0	77.0
600.00	103.0	16.0	87.0
700.00	99.0	21.0	78.0
800.00	95.0	27.0	68.0
1000.00	92.0	30.0	62.0
1000.00	101.0	36.0	65.0
2000.00	83.0	7.0	76.0
3000.00	82.0	18.0	64.0
4000.00	81.0	20.0	61.0
5000.00	83.0	17.0	66.0
Plane Wave (Horn Antennas)			
4000.00	69.0	17.0	52.0 +
5000.00	122.0	43.0	79.0
6000.00	123.0	52.0	71.0
7000.00	122.0	57.0	65.0
8000.00	123.0	52.0	71.0
9000.00	116.0	44.0	72.0
10000.00	110.0	29.0	81.0

+Exceeded dynamic range of test equipment.



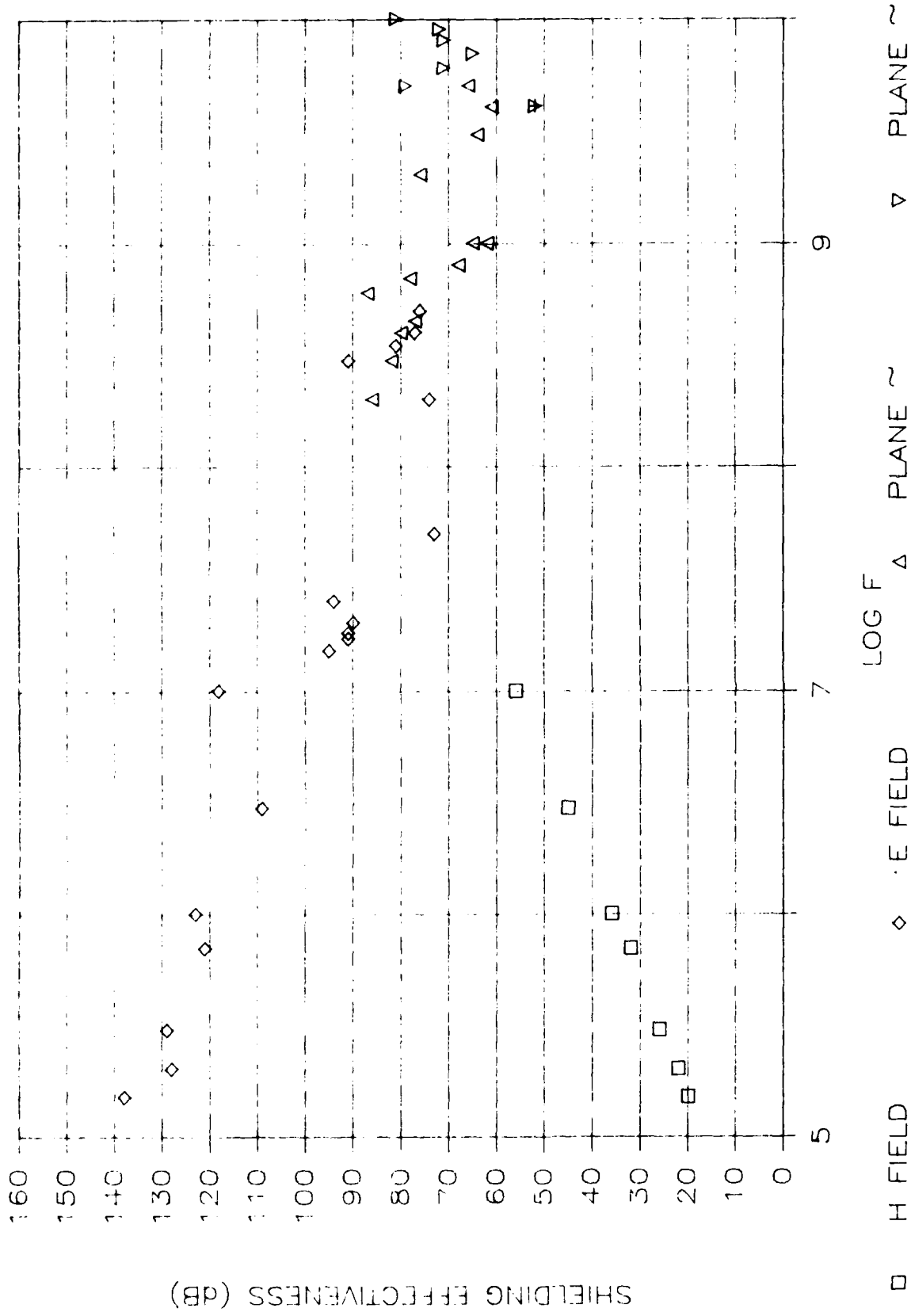

Figure A4. Shielding effectiveness vs. log of frequency for 0.002 in. lead foil.

Table A6

Data for Bronze Mesh Composite

ALUMINUM COATED SHEETROCK + BRONZE HANOVER MESH  
 PETER WILLIAMS  
 9/30/85 16:00 - 17:30

FREQ(MHz)	REF dB	SIGNAL dB	SE dB
Magnetic Field (12 in. Loops)			
0.15	77.0	16.0	61.0
0.20	76.0	9.0	67.0
0.30	78.0	8.0	70.0
0.70	75.0	-3.0	78.0
1.00	73.0	-9.0	82.0
3.00	69.0	-21.0	90.0
Electric Field (Monopole Antennas)			
0.15	107.0	-18.0	125.0 +
0.20	108.0	-27.0	135.0
0.30	113.0	-28.0	141.0 +
0.70	116.0	-24.0	140.0 +
1.00	119.0	-26.0	145.0 +
3.00	121.0	-22.0	143.0 +
10.00	111.0	6.0	105.0
15.00	100.0	-1.0	101.0
17.00	114.0	-6.0	120.0
18.00	114.0	-8.0	122.0
20.00	111.0	-7.0	118.0
25.00	118.0	-20.0	138.0 +
50.00	83.0	-28.0	111.0
200.00	87.0	-25.0	112.0
300.00	89.0	-24.0	113.0
350.00	88.0	-25.0	113.0
400.00	78.0	-23.0	101.0
500.00	79.0	-23.0	102.0
Plane Wave (Conical Antennas)			
200.00	87.0	-17.0	104.0
300.00	100.0	-12.0	112.0
400.00	99.0	-23.0	122.0
450.00	97.0	-15.0	112.0
600.00	95.0	-11.0	106.0
700.00	87.0	-9.0	96.0
800.00	86.0	-17.0	103.0
1000.00	84.0	-19.0	103.0
Plane Wave (Horn Antennas)			
5000.00	89.0	21.0	68.0 +
6000.00	87.0	18.0	69.0 +
7000.00	86.0	17.0	69.0 +
8000.00	85.0	15.0	70.0 +
9000.00	82.0	19.0	63.0 +
10000.00	82.0	21.0	61.0 +

+Exceeded dynamic range of test equipment.

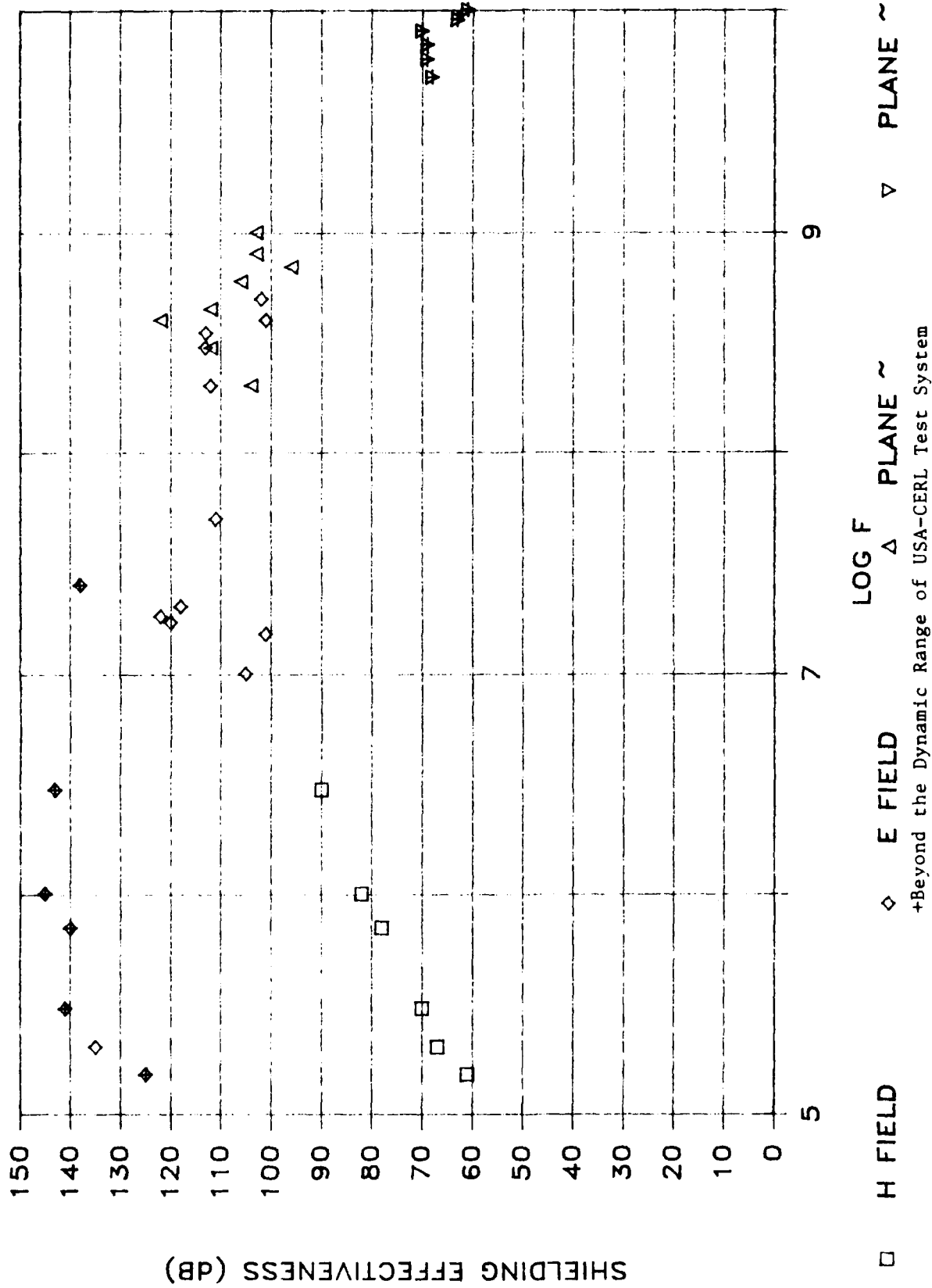

Figure A5. Shielding effectiveness vs. log of frequency for bronze mesh composite.

Table A7

Data for Copper Mesh Composite

U.S. GYPSUM COPPER MESH AND ALUMINUM FACED SHEETROCK COMPOSITE  
 5/06/86 Peter Williams-Receive and Kevin Heyen-Trans.  
 9:30 - 14:00

FREQ(MHz)	REF dB	SIGNAL dB	SE dB
Coplanar Magnetic (12 in. Loops)			
0.15	75.0	-19.0	94.0
0.20	74.0	-20.0	94.0
0.30	77.0	-20.0	97.0
0.70	73.0	-27.0	100.0
1.00	72.0	-29.0	101.0
3.00	70.0	-20.0	90.0 +
10.00	65.0	-26.0	91.0 +
Electric Field (Monopole Antennas)			
0.15	122.0	-30.0	152.0 +
0.20	111.0	-31.0	142.0 +
0.30	110.0	-32.0	142.0 +
0.70	110.0	-31.0	141.0 +
1.00	118.0	-31.0	149.0 +
3.00	118.0	-26.0	144.0 +
10.00	109.0	-1.0	110.0
15.00	126.0	-8.0	134.0
17.00	120.0	-4.0	124.0
18.00	120.0	-4.0	124.0
20.00	113.0	-4.0	117.0
25.00	121.0	-16.0	137.0
50.00	98.0	-6.0	104.0 +
200.00	104.0	-8.0	112.0 +
300.00	107.0	-5.0	112.0
350.00	105.0	-6.0	111.0
400.00	93.0	-6.0	99.0
500.00	84.0	-5.0	89.0
Plane Wave (Conical Antennas)			
200.00	69.0	-11.0	80.0 +
300.00	88.0	-9.0	97.0 +
400.00	94.0	-7.0	101.0 +
450.00	93.0	-7.0	100.0 +
600.00	99.0	0.0	99.0
700.00	92.0	0.0	92.0 +
800.00	89.0	0.0	89.0 +
1000.00	87.0	0.0	87.0 +
1000.00	81.0	12.0	69.0 +
2000.00	64.0	13.0	51.0 +
3000.00	64.0	13.0	51.0 +
4000.00	68.0	13.0	55.0 +
5000.00	67.0	12.0	55.0 +
Plane Wave (Horn Antennas)			
4000.00	61.0	11.0	50.0 +
5000.00	105.0	11.0	94.0 +
6000.00	108.0	13.0	95.0 +
7000.00	107.0	13.0	94.0 +
8000.00	110.0	13.0	97.0 +
9000.00	103.0	13.0	90.0 +
10000.00	99.0	13.0	86.0 +

+Exceeded dynamic range of test equipment.

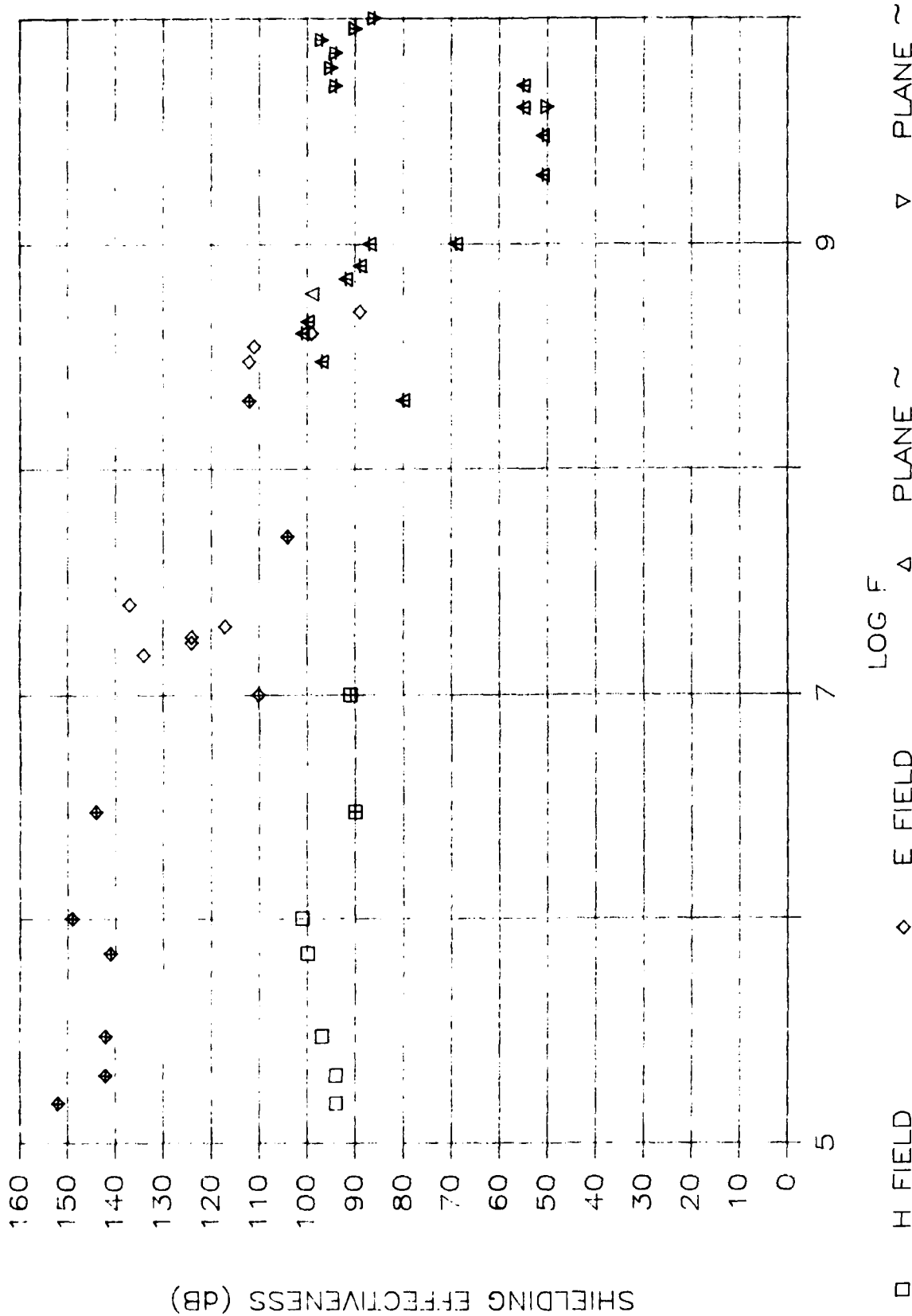

Figure A6. Shielding effectiveness vs. log of frequency for copper mesh composite.

Table A8

Data for Lead Foil Composite

U.S. GYPSUM LEAD FOIL AND ALUMINUM FACED SHEETROCK COMPOSITE  
 5/08/86 Peter Williams-Receive and Kevin Heyen-Trans.  
 9:00 - 16:00

FREQ(MHz)	REF dB	SIGNAL dB	SE dB
Coplanar Magnetic (12 in. Loops)			
0.15	72.0	15.0	57.0
0.20	71.0	11.0	60.0
0.30	73.0	10.0	63.0
0.70	71.0	-4.0	75.0
1.00	70.0	-11.0	81.0
3.00	66.0	-24.0	90.0 +
10.00	62.0	-26.0	88.0 +
Electric Field (Monopole Antennas)			
0.15	122.0	-30.0	152.0 +
0.20	111.0	-31.0	142.0 +
0.30	110.0	-32.0	142.0 +
0.70	110.0	-31.0	141.0 +
1.00	118.0	-31.0	149.0 +
3.00	118.0	-26.0	144.0 +
10.00	109.0	3.0	106.0
15.00	126.0	-6.0	132.0
17.00	120.0	-6.0	126.0
18.00	120.0	-10.0	130.0
20.00	113.0	-8.0	121.0
25.00	121.0	-17.0	138.0
50.00	98.0	-7.0	105.0
200.00	104.0	-7.0	111.0 +
300.00	107.0	-6.0	113.0
350.00	105.0	-7.0	112.0
400.00	93.0	-7.0	100.0 +
500.00	84.0	-6.0	90.0 +
Plane Wave (Conical Antennas)			
200.00	74.0	-7.0	81.0 +
300.00	86.0	-7.0	93.0 +
400.00	98.0	-7.0	105.0 +
450.00	95.0	-7.0	102.0 +
600.00	59.0	0.0	59.0
700.00	63.0	-1.0	64.0 +
800.00	59.0	3.0	56.0
1000.00	72.0	-2.0	74.0 +
1000.00	82.0	6.0	76.0 +
2000.00	63.0	7.0	56.0 +
3000.00	52.0	7.0	45.0 +
4000.00	54.0	7.0	47.0 +
5000.00	48.0	6.0	42.0 +
Plane Wave (Horn Antennas)			
4000.00	61.0	13.0	48.0 +
5000.00	105.0	12.0	93.0 +
6000.00	108.0	13.0	95.0 +
7000.00	107.0	13.0	94.0 +
8000.00	110.0	13.0	97.0 +
9000.00	103.0	13.0	90.0 +
10000.00	99.0	13.0	86.0 +

+Exceeded dynamic range of test equipment.

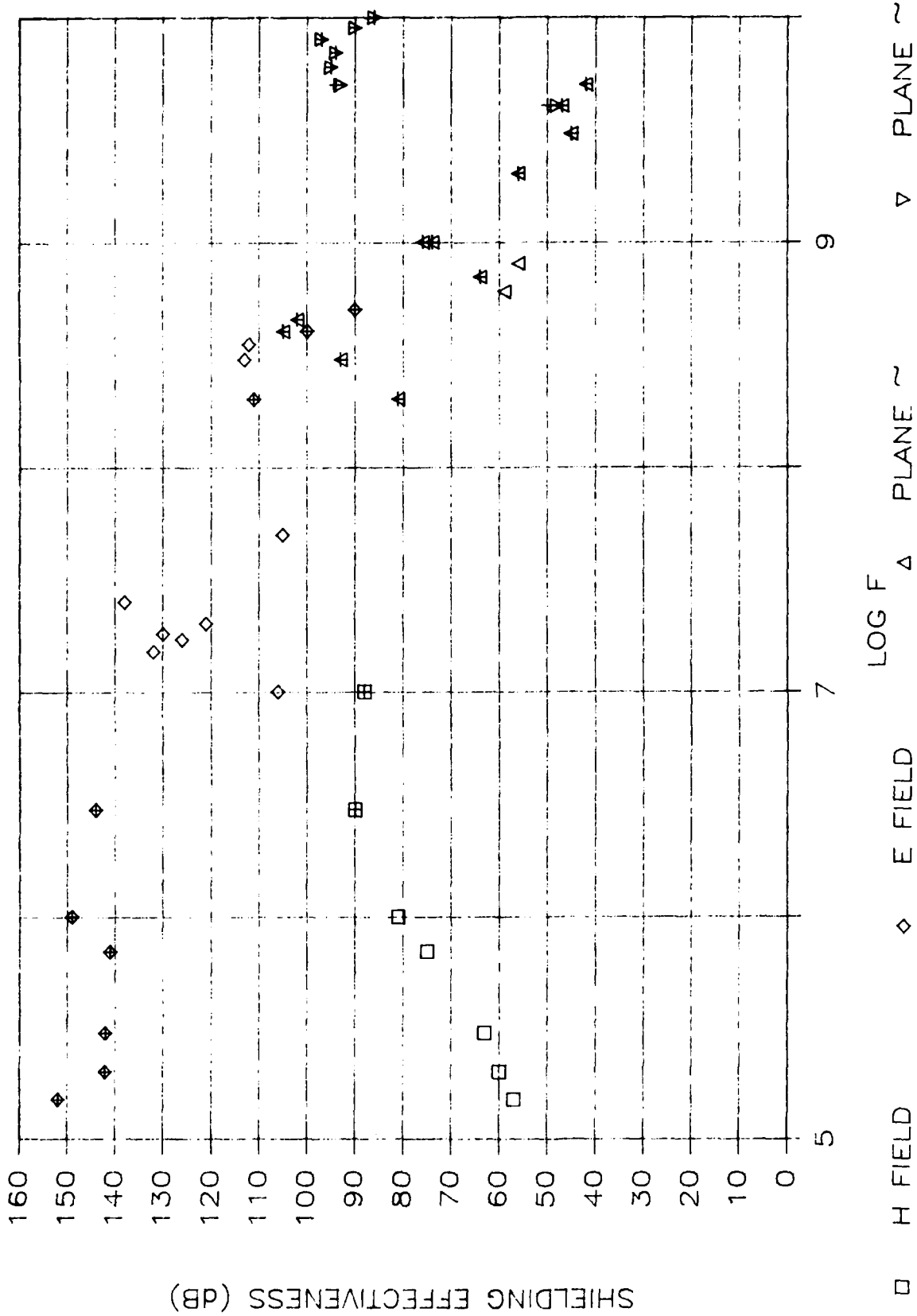

+Beyond the Dynamic Range of USA-CERL Test System

Figure A7. Shielding effectiveness vs. log of frequency for lead foil composite.

Table A9

Data for Bronze Mesh Composite: Seam Design #1

ALUMINUM COATED SHEETROCK + BRONZE HANOVER MESH  
 MOUNTING TECHNIQUE WITH SMOOTH COPPER TAPE  
 WOOD STRIP ON TOP OF SCREEN  
 PETER WILLIAMS & KEN TELEZ-REC. KEVIN HEYEN-TRANS.  
 2/07/86 16:00 - 17:30

FREQ(MHz)	REF dB	SIGNAL dB	SE dB
Magnetic Field (12 in. Loops)			
0.15	82.0	29.0	53.0
0.20	79.0	23.0	56.0
0.30	76.0	16.0	60.0
0.70	73.0	1.0	72.0
1.00	75.0	-20.0	95.0 +
3.00	71.0	-20.0	91.0 +
10.00	67.0	-20.0	87.0 +
Electric Field (Monopole Antennas)			
0.15	108.0	-20.0	128.0 +
0.20	102.0	-20.0	122.0 +
0.30	106.0	-20.0	126.0 +
0.70	110.0	-20.0	130.0 +
1.00	111.0	-20.0	131.0 +
3.00	118.0	-20.0	138.0 +
10.00	103.0	-20.0	123.0 +
15.00	109.0	-20.0	129.0 +
17.00	117.0	-20.0	137.0 +
18.00	115.0	-20.0	135.0 +
20.00	112.0	-20.0	132.0 +
25.00	115.0	-20.0	135.0 +
50.00	94.0	0.0	94.0
200.00	120.0	4.0	116.0 +
300.00	121.0	10.0	111.0
350.00	122.0	9.0	113.0
400.00	89.0	5.0	84.0 +
500.00	90.0	7.0	83.0
Plane Wave (Conical Antennas)			
200.00	104.0	1.0	103.0 +
300.00	111.0	13.0	98.0
400.00	107.0	1.0	106.0 +
450.00	108.0	10.0	98.0
600.00	107.0	12.0	95.0
700.00	102.0	9.0	93.0
800.00	103.0	9.0	94.0
1000.00	105.0	11.0	94.0
Plane Wave (Horn Antennas)			
5000.00	117.0	36.0	81.0
6000.00	115.0	35.0	80.0
7000.00	114.0	37.0	77.0
8000.00	115.0	48.0	67.0
9000.00	113.0	43.0	70.0
10000.00	108.0	38.0	70.0

+Exceeded dynamic range of test equipment.



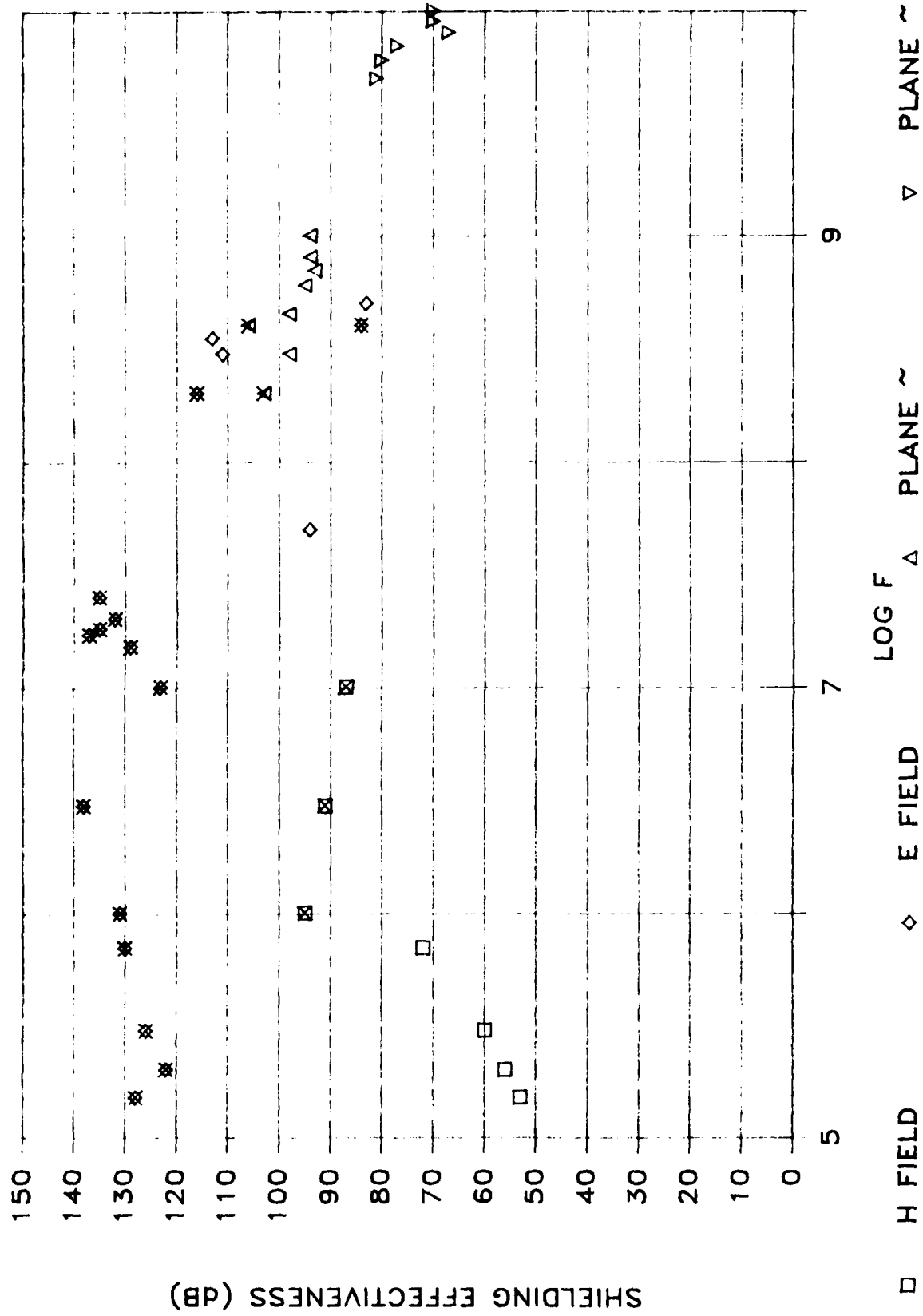

Figure A8. Shielding effectiveness vs. log of frequency for bronze mesh composite: seam design #1.

Table A10

Data for Bronze Mesh Composite: Seam Design #2

ALUMINUM COATED SHEETROCK + BRONZE HANOVER MESH  
 MOUNTING TECHNIQUE WITH EMBOSSED COPPER TAPE  
 WOOD STRIP ON INSIDE OF SCREEN  
 PETER WILLIAMS & KEN TELEZ-REC. KEVIN HEYEN-TRANS.  
 2/21/86 9:30 - 11:30

FREQ(MHz)	REF dB	SIGNAL dB	SE dB
Magnetic Field (12 in. Loops)			
0.15	81.0	30.0	51.0
0.20	80.0	24.0	56.0
0.30	77.0	16.0	61.0
0.70	73.0	-2.0	75.0
1.00	75.0	-6.0	81.0
3.00	71.0	-10.0	81.0
10.00	67.0	-20.0	87.0 +
Electric Field (Monopole Antennas)			
0.15	110.0	-20.0	130.0 +
0.20	109.0	-20.0	129.0 +
0.30	108.0	-20.0	128.0 +
0.70	109.0	-20.0	129.0 +
1.00	113.0	-20.0	133.0 +
3.00	116.0	-20.0	136.0 +
10.00	106.0	-6.0	112.0
15.00	98.0	-10.0	108.0 +
17.00	107.0	-6.0	113.0
18.00	108.0	-8.0	116.0
20.00	106.0	-10.0	116.0
25.00	110.0	-2.0	112.0
50.00	103.0	17.0	86.0
200.00	108.0	27.0	81.0
300.00	103.0	34.0	69.0
350.00	102.0	37.0	65.0
400.00	89.0	30.0	59.0
500.00	95.0	23.0	72.0
Plane Wave (Conical Antennas)			
200.00	99.0	12.0	87.0
300.00	112.0	51.0	61.0
400.00	108.0	52.0	56.0
450.00	105.0	50.0	55.0
600.00	105.0	63.0	42.0
700.00	104.0	42.0	62.0
800.00	102.0	32.0	70.0
1000.00	103.0	38.0	65.0
Plane Wave (Horn Antennas)			
5000.00	110.0	50.0	60.0
6000.00	110.0	53.0	57.0
7000.00	112.0	50.0	62.0
8000.00	114.0	58.0	56.0
9000.00	109.0	53.0	56.0
10000.00	104.0	47.0	57.0

+Exceeded dynamic range of test equipment.

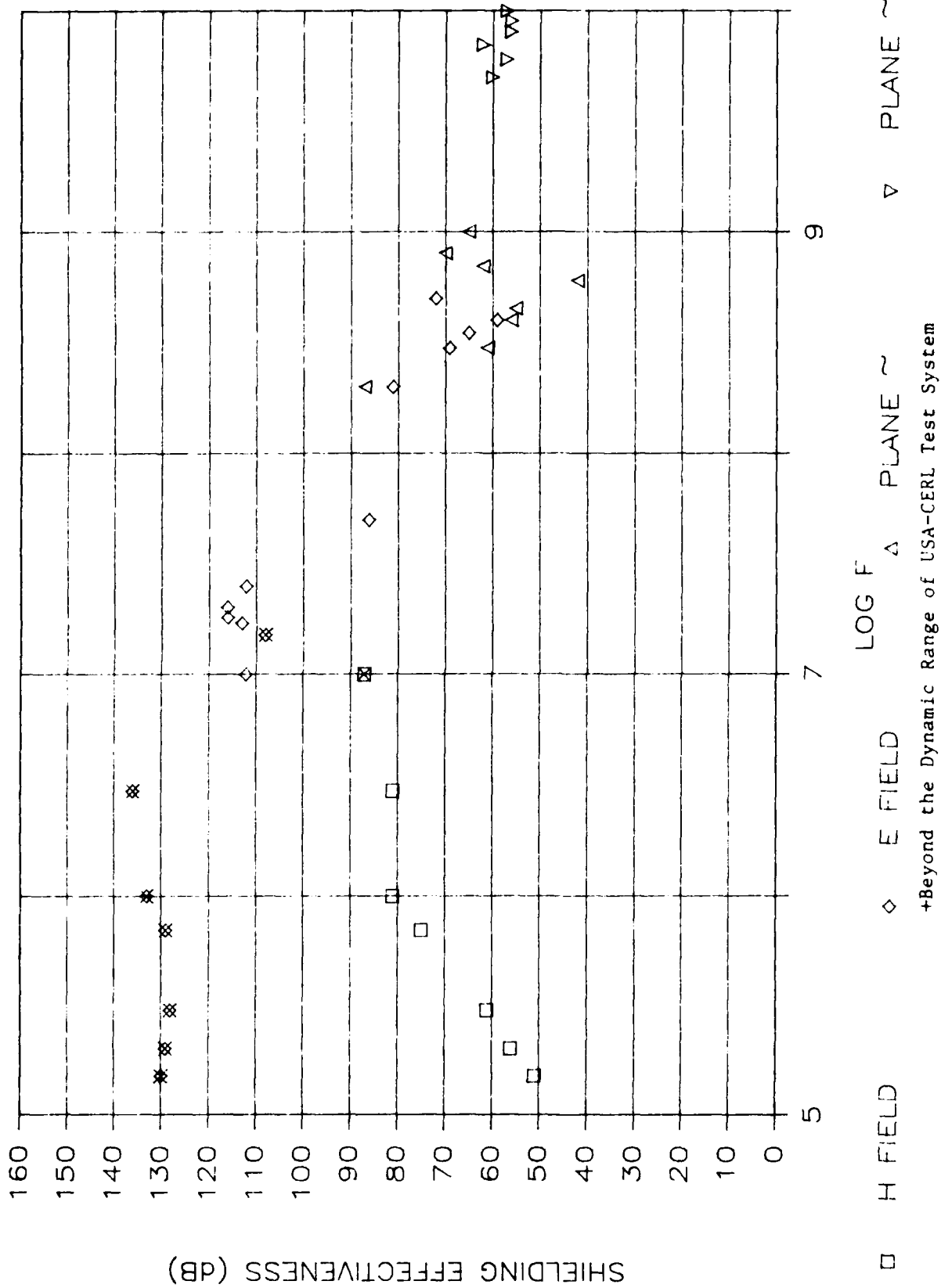

Figure A9. Shielding effectiveness vs. log of frequency for bronze mesh composite: seam design #2.

Table A11

Data for Bronze Mesh Composite: Seam Design #3

ALUMINUM COATED SHEETROCK + BRONZE HANOVER MESH  
 MOUNTING TECHNIQUE WITH EMBOSSED COPPER TAPE  
 WOOD STRIP ON INSIDE OF SCREEN: MORE SCREWS ADDED  
 PETER WILLIAMS & KEN TELEZ-REC. KEVIN HEYEN-TRANS.  
 2/24/86 9:30 - 11:30

FREQ(MHz)	REF dB	SIGNAL dB	SE dB
Magnetic Field (12 in. Loops)			
0.15	81.0	27.0	54.0
0.20	80.0	21.0	59.0
0.30	77.0	11.0	66.0
0.70	73.0	-6.0	79.0
1.00	75.0	-10.0	85.0
3.00	71.0	-20.0	91.0 +
10.00	67.0	-20.0	87.0 +
Electric Field (Monopole Antennas)			
0.15	110.0	-20.0	130.0 +
0.20	109.0	-20.0	129.0 +
0.30	108.0	-20.0	128.0 +
0.70	109.0	-20.0	129.0 +
1.00	113.0	-20.0	133.0 +
3.00	116.0	-20.0	136.0 +
10.00	106.0	-6.0	112.0
15.00	93.0	-15.0	113.0
17.00	107.0	-20.0	127.0 +
18.00	108.0	-20.0	128.0 +
20.00	106.0	-20.0	126.0 +
25.00	110.0	-20.0	130.0 +
50.00	103.0	-20.0	123.0 +
200.00	108.0	4.0	104.0
300.00	103.0	5.0	98.0
350.00	102.0	9.0	93.0
400.00	89.0	3.0	86.0
500.00	95.0	6.0	89.0
Plane Wave (Conical Antennas)			
200.00	99.0	1.0	98.0 +
300.00	112.0	12.0	100.0
400.00	108.0	4.0	104.0
450.00	105.0	4.0	101.0 +
600.00	105.0	22.0	83.0
700.00	104.0	17.0	87.0
800.00	102.0	6.0	96.0 +
1000.00	103.0	7.0	96.0 +
Plane Wave (Horn Antennas)			
5000.00	110.0	48.0	62.0
6000.00	110.0	35.0	75.0
7000.00	112.0	46.0	66.0
8000.00	114.0	48.0	66.0
9000.00	109.0	42.0	67.0
10000.00	104.0	45.0	59.0

+Exceeded dynamic range of test equipment.

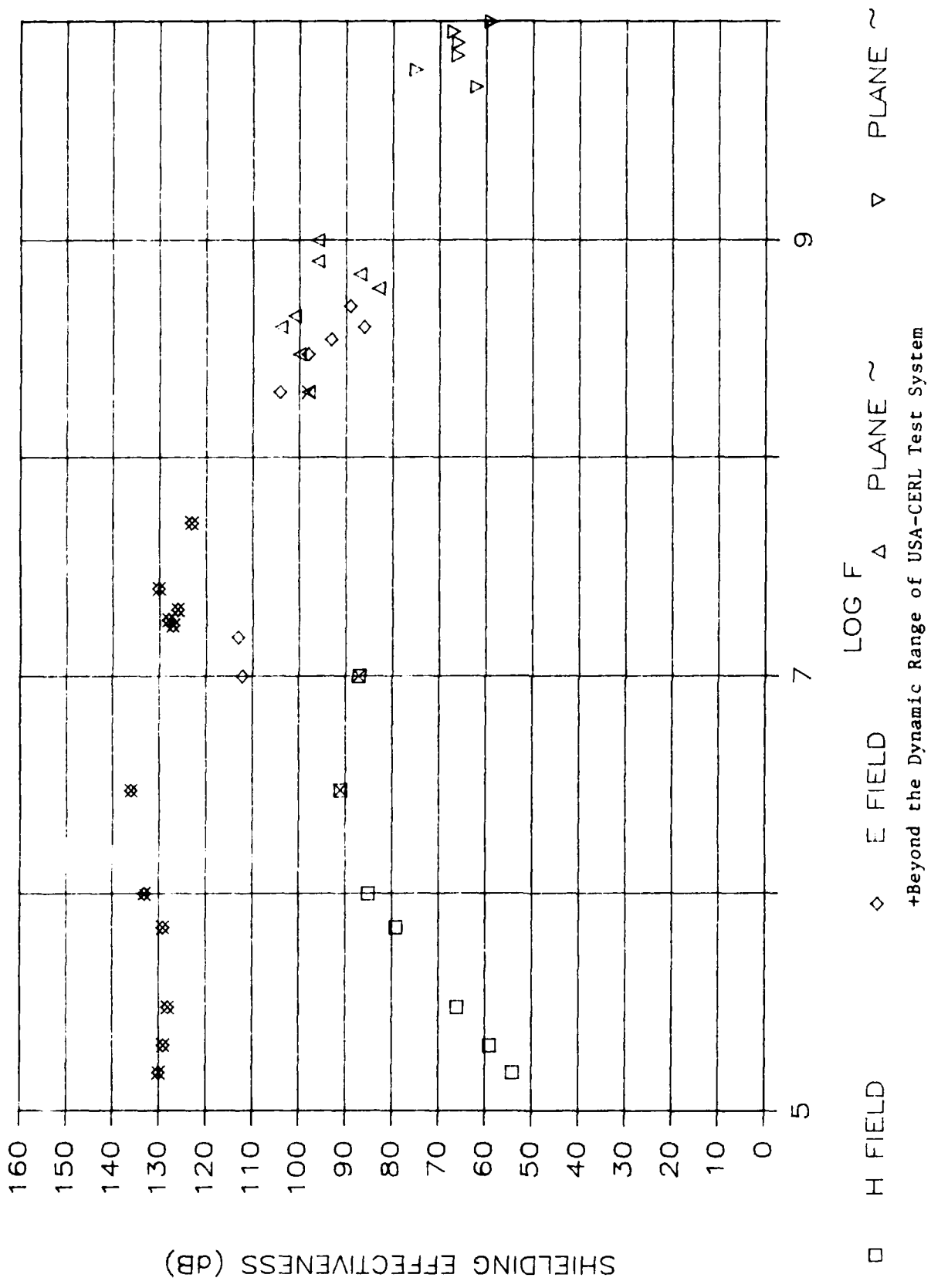

Figure A10. Shielding effectiveness vs. log of frequency for bronze mesh composite: seam design #3.

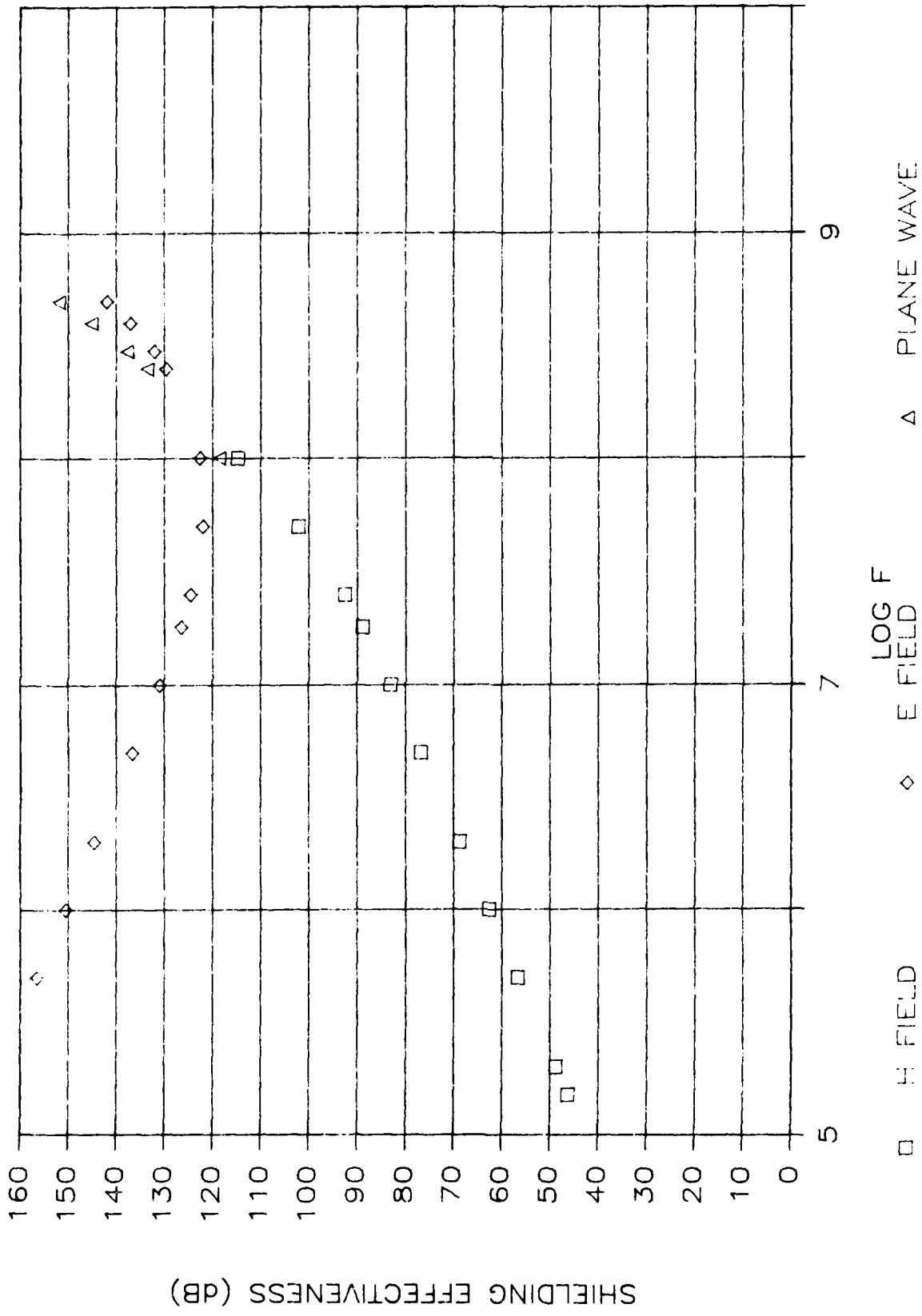

Figure A11. Shielding effectiveness vs. log of frequency for 0.00035 in. aluminum foil--theory.

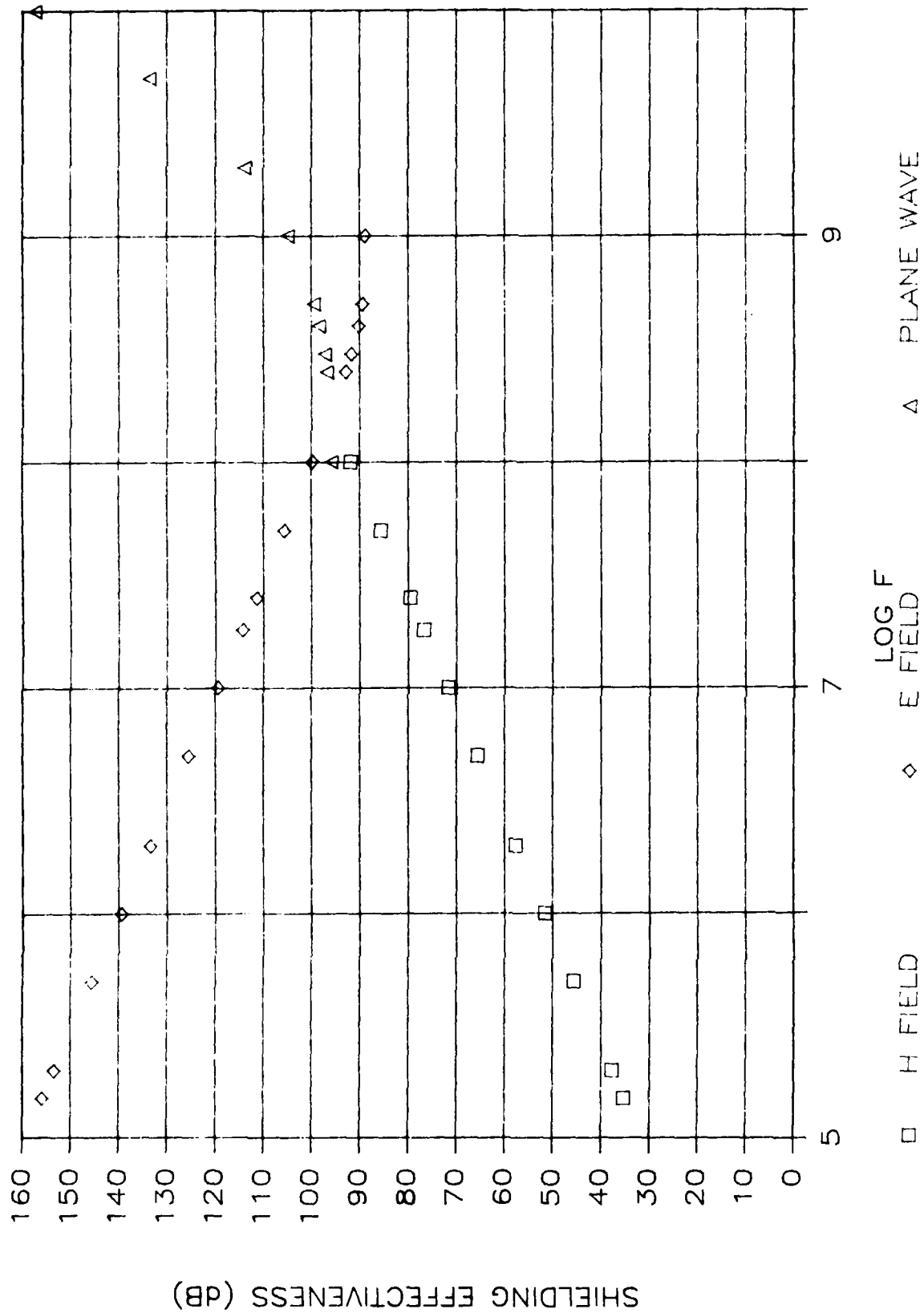

Figure A12. Shielding effectiveness vs. log of frequency for 0.00125 in. aluminum foil—theory.

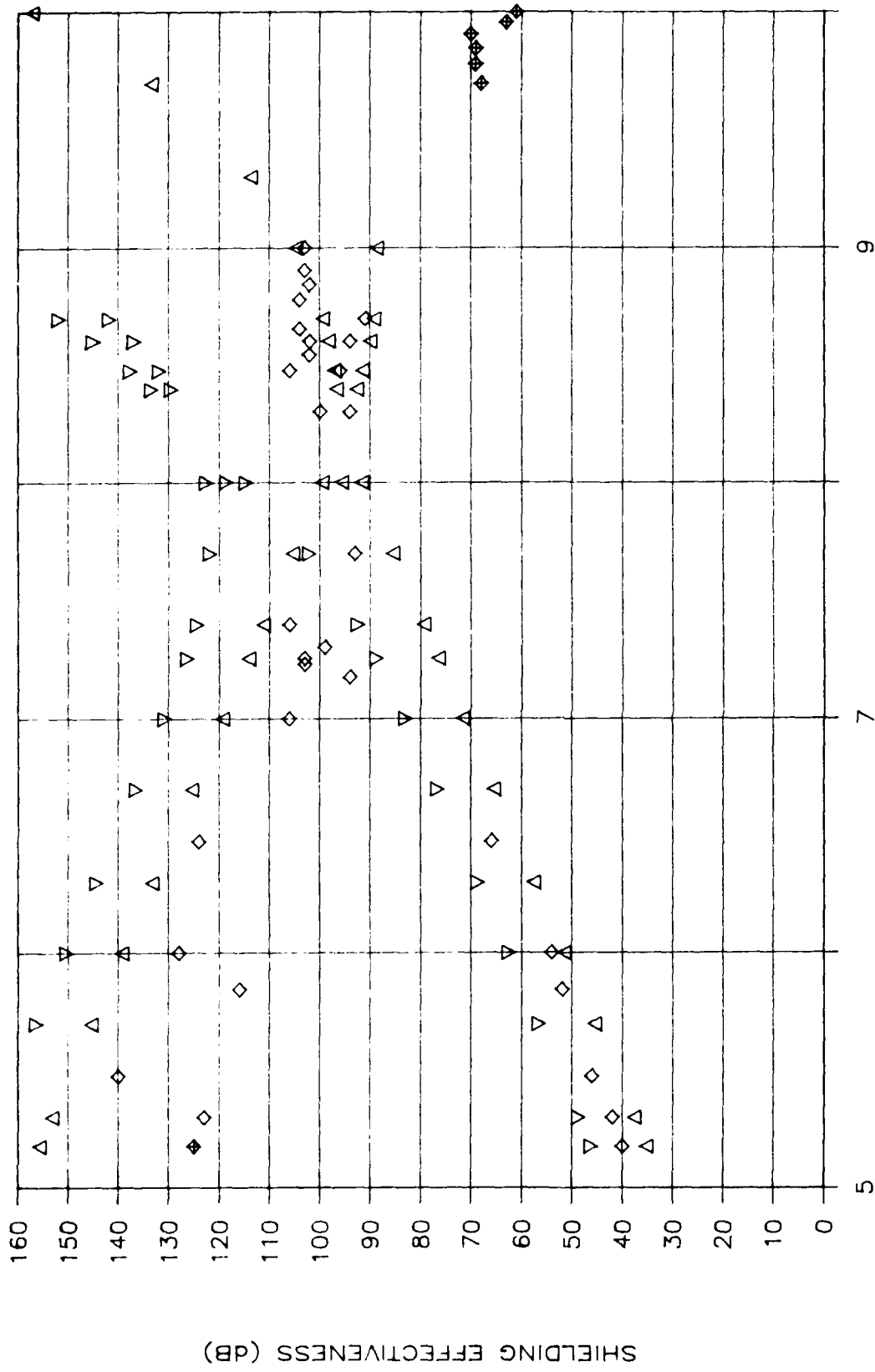

Figure A13. Shielding effectiveness vs. log of frequency for 0.00035 in. aluminum foil—theory, for 0.00125 in. aluminum foil—theory, and for 0.00035 in. aluminum foil—data.



## APPENDIX B:

### CALCULATION OF THEORETICAL SHIELDING EFFECTIVENESS

The shielding effectiveness (SE) is a figure which describes the performance of a shield in reducing electromagnetic energy. Thus, the shielding effectiveness can be described as a loss in field strength. The shielding effectiveness can be modeled by several equations,<sup>4</sup> the first of which is:

$$SE_{dB} = A_{dB} + R_{dB} + B_{dB} - \text{Leakage Effects} - \text{Standing Waves} \quad [\text{Eq B1}]$$

where  $A_{dB}$  = the absorption loss,  $R_{dB}$  = the reflection loss, and  $B_{dB}$  = the re-reflection loss. Each of these terms can be defined by various equations.

The absorption term can be defined in terms of thickness (t) in mils (thousandths of an inch) and frequency (f) in MHz in english units as:

$$A_{dB} = 3.338t_{\text{mils}} \sqrt{f \text{ MHz } \mu_r \sigma_r} \text{ dB} \quad [\text{Eq B2}]$$

where,  $\mu$  and  $\sigma$  are the permeability and the conductivity of the shield material relative to copper.

The reflection loss relations are predicated upon an impedance mismatch at the metal-barrier interfaces. The reflection term can be defined as:

$$R_{dB} = 20 \log_{10} [(1 + K)^2 / 4K] \text{ dB} \quad [\text{Eq B3}]$$

Where K is defined as the ratio of the wave impedance to the metal-barrier impedance:

$$K = \frac{1}{2} \pi r f \epsilon_0 \sqrt{2 \pi f \mu / \sigma} \text{ for high impedance (magnetic fields)} \quad [\text{Eq B4}]$$

$$= r \sqrt{2 \pi f \sigma \mu_0 / \mu_r} \text{ for low impedance (electric) fields} \quad [\text{Eq B5}]$$

$$= 1 / \sqrt{2 \pi f \mu \epsilon_0 / \sigma_0} \text{ for plane waves} \quad [\text{Eq B6}]$$

The re-reflection term can be described in terms of the wave and metal-barrier impedance:

$$B_{dB} = 20 \log_{10} (1 - [(K - 1)/(K + 1)]^2 \times 10^{-0.1A_{dB}} (\cos 0.23A_{dB} - \sin 0.23A_{dB})) \quad [\text{Eq B7}]$$

where  $A_{dB}$  is defined in Equation B2.

<sup>4</sup>Donald R. J. White, *A Handbook on Electromagnetic Shielding Materials and Performance* (Don White Consultants, Inc., 1980) pp 1.14-1.35

A BASIC program incorporating these equations was written to calculate the theoretical shielding effectiveness. (A printout of this program is included below.)

Leakage effects may be due to one or more of the following situations which exist in any real life shield: seams, doors, cover plates, vents, holes, apertures, and non-homogeneous materials.

Losses due to standing waves involve resonance effects at higher frequencies where the enclosures act as microwave cavities. This results in areas within a shielded enclosure which exhibit poorer performance (lower shielding effectiveness).

<sup>5</sup>White, p 1.35.

<sup>6</sup>White, p 1.36.

```
10 REM   This program calculates theoretical shielding
20 REM   effectiveness.
30 REM
40 REM   Written by Pete Williams      March 1984
50 REM
60 REM   Modified by Mike McInerney   May 1984
70 REM
80 REM
90 REM
100 CLS
110 DIM AB(23),RE(23),RR(23),SH(23),F(23),K(23)
120 DATA .025,.050,.150,.200,.500,1.00,2.00,5.00,10.00,18.00
130 DATA 25.00,50.00,100.00,250.00,300.00,400.00,500.00
140 DATA 1000.00,2000.00,5000.00,10000.00
150 PRINT "WHAT TYPE OF FIELD"
160 PRINT "TYPE HIGH FOR HIGH IMPEDANCE FIELD"
170 PRINT "TYPE LOW FOR LOW IMPEDANCE FIELD"
180 PRINT "TYPE PLANE FOR PLANE WAVE"
190 PRINT:INPUT E$
200 IF (ASC(E$)=72) OR (ASC(E$)=104) THEN 240
210 IF (ASC(E$)=76) OR (ASC(E$)=108) THEN 240
220 IF (ASC(E$)=80) OR (ASC(E$)=112) THEN 240
230 GOTO 150
240 P=3.1415927#
250 N=1.257E-06
260 PRINT "INPUT PERMEABILITY OF METAL"
270 INPUT U
280 PRINT "INPUT RELATIVE PERMEABILITY OF METAL"
290 INPUT Y
300 PRINT "INPUT CONDUCTIVITY OF METAL"
310 INPUT C
320 PRINT "INPUT CONDUCTIVITY RELATIVE TO COPPER"
330 INPUT G
340 E=8.854E-12
350 D=.3048
360 CC=5.8E+07
370 PRINT "INPUT PERMITIVITY OF METAL"
380 INPUT EE
390 PRINT "INPUT RELATIVE PERMITIVITY OF METAL"
400 INPUT ER
410 CLS:PRINT "INPUT METAL THICKNESS IN INCHES"
420 INPUT T
430 PRINT "INPUT TYPE OF METAL"
440 INPUT M$
```

```

450 PRINT: PRINT :PRINT "Calculating Shielding Effectiveness."
460 RESTORE:FOR I=1 TO 21:READ F(I)
470 IF (ASC(E$)=80) OR (ASC(E$)=112) THEN 510
480 IF (ASC(E$)=72) OR (ASC(E$)=104) THEN 500
490 K=D*SQR(2*P*F(I)*1000000!*C*N/Y):GOTO 520
500 K=1/(2*P*.3048*F(I)*1000000!*E*SQR(2*P*F(I)*1000000!*U/C)):GOTO 520
510 K=1/SQR(2*P*F(I)*1000000!*Y*E/C)
520 Z=(1+K)^2/(4*K)
530 RE(I)=20*(LOG(Z)/LOG(10))
540 AB(I)=3.338*T*SQR(F(I)*1000000!*Y*G)
550 X=((K-1)/(K+1))^2*10^(-.1*AB(I)):K(I)=K
560 W=(1-X*COS(.23*AB(I)))^2
570 V=(X*SIN(.23*AB(I)))^2
580 S=SQR(W+V)
590 RR(I)=20*(LOG(S)/LOG(10))
600 SH(I)=RE(I)+AB(I)+RR(I)
610 NEXT I
620 CLS
630 IF (ASC(E$)=72) OR (ASC(E$)=104) THEN 660
640 IF (ASC(E$)=80) OR (ASC(E$)=112) THEN 670
650 LPRINT "          ", "LOW IMPEDANCE FIELD":LPRINT "          "
   (LOOP TEST)":GOTO 680
660 LPRINT "          ", "HIGH IMPEDANCE FIELD":LPRINT "          "
   (DIPOLE TEST)":GOTO 680
670 LPRINT "          ", "PLANE WAVE FIELD":LPRINT "          "
   (HORN TEST)"
680 LPRINT:LPRINT "          ";T*1000;" MILS OF ";M$:LPRINT
690 LPRINT "          CONDUCTIVITY=",C," RELATIVE CONDUCTIVITY=",G
700 LPRINT:LPRINT "          PERMITIVITY=",EE," RELATIVE PERMITIVITY=",ER
710 LPRINT:LPRINT "          PERMEABILITY=",U," RELATIVE PERMEABILITY=",Y
720 LPRINT
730 LPRINT " FREQUENCY";"          ABSORPTION";"          REFLECTION";"          REREFLECTION
";" SHIELDING"
740 LPRINT " (MHZ) ";"          (dB) ";"          (dB) ";"          (dB)
";" (dB)
750 LPRINT "-----";"-----";"-----";"-----";"-----";"-----":LPRINT
760 FOR J=1 TO 21
770 LPRINT USING "#####.####          ";F(J);
780 LPRINT USING "####.####          ";AB(J);RE(J);RR(J);SH(J)
790 NEXT J
800 LPRINT CHR$(12)
810 PRINT:PRINT"WANT TO DO MORE CALCULATIONS FOR A NEW THICKNESS"
820 INPUT Y$
830 IF (ASC(Y$)=89) OR (ASC(Y$)=121) THEN 410
840 IF (ASC(Y$)<>78) AND (ASC(Y$)<>110) THEN 810
850 PRINT"WANT TO DO CALCULATIONS FOR A DIFFERENT METAL"
860 INPUT D$
870 IF (ASC(D$)=89) OR (ASC(D$)=121) THEN 150
880 IF (ASC(D$)<>78) AND (ASC(D$)<>110) THEN 850
890 PRINT"WANT TO DO CALCULATIONS FOR A DIFFERENT WAVE BUT SAME MATERIAL?"
900 INPUT N$
910 IF (ASC(N$)=78) OR (ASC(N$)=110) THEN 980
920 IF (ASC(N$)<>89) AND (ASC(N$)<>121) THEN 890
930 PRINT "INPUT NEW TYPE OF FIELD"
940 PRINT "TYPE HIGH FOR HIGH IMPEDANCE FIELD"
950 PRINT "TYPE LOW FOR LOW IMPEDANCE FIELD"
960 PRINT "TYPE PLANE FOR PLANE WAVE"
970 INPUT E$:RESTORE:GOTO 460
980 END

```

## APPENDIX C:

### SYMBOLS AND ABBREVIATIONS

- dB = decibels
- r = source to shield distance
- f = frequency
- t = thickness
- M = meters
- Hz = hertz or cycles per second
- KHz = kilohertz or thousands of hertz
- MHz = megahertz or millions of hertz
- GHz = gigahertz or billions of hertz
- SE = shielding effectiveness
- $O_r$  = reference power level
- $S_r$  = signal level
- $E_1$  = voltage without panel
- $E_2$  = voltage with panel
- $P_1$  = power without panel
- $P_2$  = power with panel
- $\epsilon_o$  = permittivity of free space and copper
- mils = thousandths of an inch
- whips = monopole antennas
- $\mu$  = permeability of shielding material =  $\mu_o \mu_r$
- $\sigma$  = conductivity of shielding material in mhos/m
- $\mu_o$  = absolute permeability of air =  $4 \times 10^{-7}$  henrys/m
- $\mu_r$  = permeability shield material relative to air or copper
- $\sigma_r$  = conductivity of shield material relative to copper
- $\pi \approx = 3.14159$
- A = absorption loss
- R = reflection loss
- B = re-reflection loss

## USA-CERL DISTRIBUTION

Chief of Engineers  
ATTN: CEEC-E  
ATTN: CEEC-RS

FESA, ATTN: Library 22060  
ATTN: DET III 79906

US Army Engineer Districts  
ATTN: Library (41)

US Army Engineer Divisions  
ATTN: Library (14)

DNA ATTN: NADS 20305

INSCOM - Ch, Instl. Div  
ATTN: Facilities Engineer (3)

USACC, ATTN: Facilities Engr (2)

SHAPE 09055  
ATTN: Surv. Section, CCB-OPS  
Infrastructure Branch, LANDA

US Army Engineer District  
New York 10007

ATTN: Chief, Design Br

Pittsburgh 15222

ATTN: Chief, Engr Div

Philadelphia 19106

ATTN: Chief, NAPEN-D

Baltimore 21203

ATTN: Chief, Engr Div

Norfolk 23510

ATTN: Chief, NAOEN-M

ATTN: Chief, NAOEN-D

Huntington 25721

ATTN: Chief, ORHED-D

Wilmington 28401

ATTN: Chief, SAWEN-DS

ATTN: Chief, SAWEN-D

Charleston 29402

ATTN: Chief, Engr Div

Savannah 31402

ATTN: Chief, SASAS-L

Jacksonville 32232

ATTN: Const Div

ATTN: Design Br., Structures Sec.

Mobile 36628

ATTN: Chief, SAMEN-D

ATTN: Chief, SAMEN-C

Nashville 37202

ATTN: Chief, ORNED-D

Memphis 38103

ATTN: Chief, LMMED-DT

ATTN: Chief, LMMED-DM

Vicksburg 39180

ATTN: Chief, Engr Div

Louisville 40201

ATTN: Chief, Engr Div

Detroit 48231

ATTN: Chief, NCEED-T

St. Paul 55101

ATTN: Chief, ED-D

Chicago 60604

ATTN: Chief, NCCED-DS

Rock Island, 61201

ATTN: Chief, Engr Div

ATTN: Chief, NCRE-D

St. Louis 63101

ATTN: Chief, ED-D

Kansas City 64106

ATTN: Chief, Engr Div

Omaha 68102

ATTN: Chief, Engr Div

New Orleans 70180

ATTN: Chief, LMMED-DG

Little Rock 72203

ATTN: Chief, Engr Div

Tulsa 74102

ATTN: Chief, Engr Div

Fort Worth 76102

ATTN: Chief, CESWF-ED-D

ATTN: CESWF-IM-C (Library)

ATTN: CESWF-ED-DA (5)

Galveston 77550

ATTN: Chief, SWGAS-L

ATTN: Chief, SWGED-DS

ATTN: Chief, SWGED-DM

Albuquerque 87103

ATTN: Chief, Engr Div

Los Angeles 90053

ATTN: Chief, SPLED-D

San Francisco 94105

ATTN: Chief, Engr Div

Sacramento 95814

ATTN: Chief, SPKED-D

US Army Engineer District

Far East 96301

ATTN: Chief, Engr Div

Portland 97208

ATTN: Chief, DB-6

ATTN: Chief, DB-3

Seattle 98124

ATTN: Chief, NPSCO

ATTN: Chief, EN-DB-EM

ATTN: Chief, EN-DB-ST

ATTN: Chief, NPSEN-PL-WC

Walla Walla 99382

ATTN: Chief, Engr Div

Alaska 99501

ATTN: Chief, NPASA-R

US Army Engineer Division

New England 02154

ATTN: Chief, NEDED-T

Middle East (Rear) 22601

ATTN: Chief, MEDED-T

North Atlantic 10007

ATTN: Chief, NADEN-T

South Atlantic 30303

ATTN: Chief, SADEN-TS

ATTN: Chief, SADEN-TE/TM

Huntsville 35807

ATTN: Chief, HNDED-CS

ATTN: Chief, HNDED-ME

ATTN: Chief, HNDED-SR

ATTN: Chief, HNDED-FD

Ohio River 45201

ATTN: Chief, Engr Div

North Central 60605

ATTN: Chief, Engr Div

Missouri River 68101

ATTN: Chief, MRDED-T

Southwestern 75202

ATTN: Chief, SWEDE-TS

ATTN: Chief, SWEDE-TM

ATTN: Chief, SWDED-T

ATTN: SWDED (Library)

South Pacific 94111

ATTN: Chief, SPDED-TG

Pacific Ocean 96858

ATTN: Chief, Engr Div

ATTN: Chief, FM&S Branch

ATTN: Chief, PODED-D

North Pacific 97208

ATTN: Chief, Engr Div

ADEA Fort Lewis, WA 98116-5000  
ATTN: AFVO-TRA-EN

USA NATICK  
R&D Cntr 01760-5017

Harry Diamond Labs 20783

ATTN: DELHD-NW-E

ATTN: DELHD-NW-EA

ATTN: DELHD-NW-EC

ATTN: DELHD-NW-ED

ATTN: DELHD-NW-EE

Naval Air Systems Command

ATTN: Library

Hanson AFB, MA 01731

ATTN: HQ AFSC

ATTN: ESD/OCR-3

Kirtland AFB, NM 87117

ATTN: AFWL/DES

ATTN: AFWL/DYC

Tyndall AFB, FL 32403

ATTN: AFESC/TBT

ATTN: AFESC/RDCF

Wright-Patterson AFB, OH 45433

ATTN: ASD/ENAMA

ATTN: AFWAL/MLSE

Naval Civil Engr Lab

ATTN: Library 93041

Defense Technical Info. Center 22314

ATTN: DDA (2)

US Govt Print Office 22304

Receiving Sect/Depository Copies (2)

National Bureau of Standards 20899

END

DATE

FILMED

5-88

DTIC