

AO-A190 293

BLISTERING OF BUILT-UP ROOF MEMBRANES PRESSURE
MEASUREMENTS(U) COLD REGIONS RESEARCH AND ENGINEERING
LAB HANNOVER NH C KORHONEN OCT 86 CRREL-SR-86-29

1/1

UNCLASSIFIED

F/G 13/13

ML

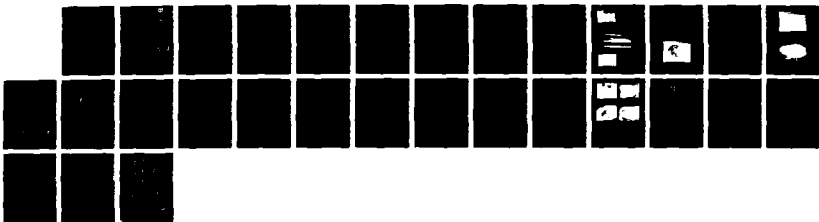

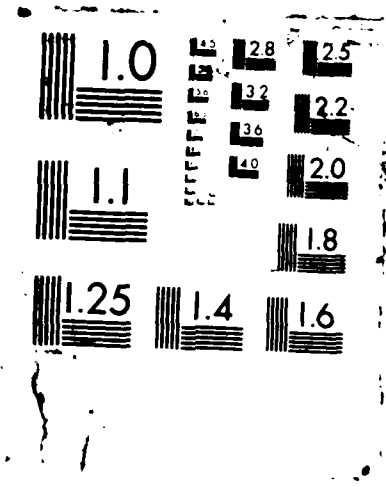

4

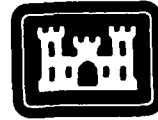

**US Army Corps
of Engineers**

Cold Regions Research &
Engineering Laboratory

Special Report 86-29

October 1986

DTIC FILE COPY

Blistering of built-up roof membranes Pressure measurements

Charles Korhonen

AD-A190 293

DTIC
ELECTE
FEB 09 1988
S D
H

Prepared for
OFFICE OF THE CHIEF OF ENGINEERS

Approved for public release; distribution is unlimited.

88 2 2 006

AD-A190293

SECURITY CLASSIFICATION OF THIS PAGE

REPORT DOCUMENTATION PAGE

Form Approved
OMB No 0704-0188
Exp Date Jun 30, 1986

1a. REPORT SECURITY CLASSIFICATION Unclassified		1b. RESTRICTIVE MARKINGS	
2a. SECURITY CLASSIFICATION AUTHORITY		3. DISTRIBUTION / AVAILABILITY OF REPORT Approved for public release; distribution is unlimited.	
2b. DECLASSIFICATION / DOWNGRADING SCHEDULE		5. MONITORING ORGANIZATION REPORT NUMBER(S)	
4. PERFORMING ORGANIZATION REPORT NUMBER(S) Special Report 86-29		7a. NAME OF MONITORING ORGANIZATION Office of the Chief of Engineers	
6a. NAME OF PERFORMING ORGANIZATION U.S. Army Cold Regions Research and Engineering Laboratory	6b. OFFICE SYMBOL (if applicable) CRREL	7b. ADDRESS (City, State, and ZIP Code) Washington, D.C. 20314-1000	
6c. ADDRESS (City, State, and ZIP Code) Hanover, New Hampshire 03755-1290		9. PROCUREMENT INSTRUMENT IDENTIFICATION NUMBER	
8a. NAME OF FUNDING / SPONSORING ORGANIZATION	8b. OFFICE SYMBOL (if applicable)	10. SOURCE OF FUNDING NUMBERS	
8c. ADDRESS (City, State, and ZIP Code)		PROGRAM ELEMENT NO. 6.27.30A	PROJECT NO. 4A762730 AT42
		TASK NO. BS	WORK UNIT ACCESSION NO. 017
11. TITLE (Include Security Classification) Blistering of Built-up Roof Membranes: Pressure Measurements			
12. PERSONAL AUTHOR(S) Charles Korhonen			
13a. TYPE OF REPORT	13b. TIME COVERED FROM _____ TO _____	14. DATE OF REPORT (Year, Month, Day) October 1986	15. PAGE COUNT 28
16. SUPPLEMENTARY NOTATION			
17. COSATI CODES		18. SUBJECT TERMS (Continue on reverse if necessary and identify by block number)	
FIELD	GROUP	Built-up roofs	
		Roof repair	
		Roofs	
19. ABSTRACT (Continue on reverse if necessary and identify by block number) Several blisters in built-up roof membranes were instrumented with pressure and temperature sensors. Internal blister pressures varied from positive during the heat of the day to negative during the cool of the night; these pressure changes cause blisters to grow. Air is drawn into the blister at night. When exposed to sunshine, the air rapidly expands before it can escape. Water is not necessary to cause growth. Blisters grow best when the days are hot and the nights are cool. Pressures apparently do not occur within the insulated space of a roof to cause blisters. Reflective coatings may help to slow blister growth. Growth can be stopped by using a miniature pressure relief valve.			
20. DISTRIBUTION / AVAILABILITY OF ABSTRACT <input checked="" type="checkbox"/> UNCLASSIFIED/UNLIMITED <input type="checkbox"/> SAME AS RPT <input type="checkbox"/> DTIC USERS		21. ABSTRACT SECURITY CLASSIFICATION Unclassified	
22a. NAME OF RESPONSIBLE INDIVIDUAL Charles Korhonen		22b. TELEPHONE (Include Area Code) 603-646-4438	22c. OFFICE SYMBOL CRREL-EC

PREFACE

This report was prepared by Charles J. Korhonen, Research Civil Engineer, Civil Engineering Research Branch, Experimental Engineering Division, U.S. Army Cold Regions Research and Engineering Laboratory. The work was funded under DA Project 4A762730AT42, Design, Construction and Operations Technology for Cold Regions, Base Support, Cold Regions Facilities Maintenance Technology, Work Unit 017, Maintenance and Rehabilitation of Military Facilities in Cold Regions. Wayne Tobiasson, Charles McKenna and John Kalafut of CRREL technically reviewed this report.

The contents of this report are not to be used for advertising or promotional purposes. Citation of brand names does not constitute an official endorsement or approval of the use of such commercial products.

CONTENTS

	Page
Abstract.....	i
Preface.....	ii
Conversion factors.....	v
Introduction.....	1
Field study.....	2
Instrumentation.....	2
The blisters.....	4
Results.....	7
Positive pressures.....	12
Negative pressures.....	15
Insulation pressures.....	16
Maintenance techniques.....	16
Traditional.....	16
Reflective coating.....	16
Pressure relief valve.....	17
Summary and conclusions.....	19
Literature cited.....	19
Appendix A: Data acquisition system.....	21

ILLUSTRATIONS

Figure

1. Blister that had been instrumented with a pressure sensor and then opened to show the needle position.....	3
2. Close-up of the side-vented needle fabricated from 1/8-in. O.D. stainless steel tubing.....	3
3. Blister instrumented with a pressure transducer and a thermocouple.....	3
4. The Devens blister after it was cut.....	4
5. Underside of the Devens blister.....	6
6. Evidence of foaming on the Devens blister.....	6
7. Temperatures and pressures for the Devens blister.....	7
8. Temperatures and pressures for CRREL blister #1.....	9
9. Temperatures and pressures for CRREL blister #2.....	9
10. Temperatures and pressures for CRREL blister #3.....	10

Accession For	
NTIS GRA&I	<input checked="" type="checkbox"/>
DTIC TAB	<input type="checkbox"/>
Unannounced	<input type="checkbox"/>
Justification	
By	
Distribution/	
Availability Codes	
Avail and/or	
Dist	Special
A-1	



11. Temperatures and pressures for CRREL blister #4.....	11
12. Pressure increases of dry and saturated air.....	11
13. Possible air paths.....	12
14. Blister force diagram.....	13
15. Perimeter uplift force vs time prior to growth.....	14
16. One of two traditional methods of patching a ruptured blister...	17
17. Blister pressure relief valve.....	18
18. Temperatures and pressures before and after valve was installed.....	18

TABLES

Table

1. Blister measurements.....	5
2. Forces on the Devens blister just prior to growth.....	15

CONVERSION FACTORS: U.S. CUSTOMARY TO METRIC (SI) UNITS OF MEASUREMENT

These conversion factors include all the significant digits given in the conversion tables in the ASTM Metric Practic Guide (E 380), which has been approved for use by the Department of Defense. Converted values should be rounded to have the same precision as the original (See E 380).

Multiply	By	To obtain
inch	0.0254*	meter
pound	0.4535924	kilogram
lb/in. ²	6894.757	pascal
degrees Fahrenheit	$^{\circ}\text{C} = (^{\circ}\text{F} - 32)/1.8$	degrees Celsius

*Exact

BLISTERING OF BUILT-UP ROOF MEMBRANES:
PRESSURE MEASUREMENTS

Charles Korhonen

INTRODUCTION

Blisters are voids caused by the expansion of a gas within a roofing system. They usually occur between the plies of a built-up membrane, but they can also occur between the built-up membrane and its substrate. Although blisters are considered to be a major roofing problem (The Roofing Spec 1979), they will not leak if they are intact. But because the roof surface is raised and unsupported at a blister, the potential for damage and subsequent leakage is great. Foot traffic, dropped objects and increased weathering on the raised, stretched surface of a blister are all likely to lead to damage. Of course, once a blister is damaged, water can enter. Even if they do not leak, blisters can contribute to the general deterioration of a roof by affecting drainage patterns and creating ponds.

Currently there are few options available for dealing with a blister. It is common to recoat portions of blisters where gravel has eroded off and the felts are exposed. When a blister ruptures, it is cut open, dried (if water is present), and patched with cement and reinforcing fabric. Patching is a slow, tedious process and is often delayed as long as possible. The U.S. Army Corps of Engineers (1974), in its guidance on roofing, stated that blisters should be disregarded if they are intact: "Only if the felts disintegrate or are cracked should they (blisters) be repaired."

The mechanics of blisters has not been well documented. Over the years several theories have been developed to explain them. One theory suggests that blisters arise from pockets of air and water. Whether it is in the roofing felts or in the insulation, water can vaporize in the intense heat of the sun and expand to displace the membrane, forming a blister. The hotter the climate, the greater the chance for blisters. Without question, water can significantly increase air pressures in a confined space, but some experts doubt that water is needed at all. They feel

that blisters will develop as long as there is a small void built into the mopping bitumens. However, these voids will not develop into blisters unless they can breathe. The mere expansion of the air within a void does not account for large blisters. The voids must take on new air at night and expand a bit more the following day. Without some mechanism such as this, growth, or at least large blisters, would not be possible.

I conducted this study to develop a clearer picture of blister mechanics and to improve current maintenance techniques. I measured the diurnal changes in pressure inside several blisters and developed some new approaches for dealing with blisters.

FIELD STUDY

Instrumentation

A differential pressure sensor was used to measure blister pressures in this study. A Microswitch (Model 143PC03D) was chosen because it was small, environmentally tough and capable of sensing the expected range of pressures. The sensor's output signal was modified to be read by either a Hewlett Packard model 7155B strip chart recorder or an Omnidata Model DP 212 (Datapod) electronic recorder. Both devices functioned well at recording data, but the Datapod proved to be superior for data reduction. It was a simple matter to remove the memory chip from the Datapod and read the data into a computer for processing. Manual tabulation of strip chart data, on the other hand, was tedious. Appendix A describes the Datapod set-up used in this study.

Internal pressures were measured by inserting a hypodermic-type needle through the wall of a blister (Fig. 1). For this operation a side-vented needle (Fig. 2) worked best. Needles that were open only at the end became plugged with bitumen. The needle was sealed to the pressure sensing port of the Microswitch sensor. The sensor's other port was connected to a plastic tube vented in a bottle of desiccant at atmospheric pressure. This prevented moisture from entering the port and damaging the sensor.

Care was taken to insert the needle during the early morning or late afternoon when blister pressures were low. Inserting the needle when pressures were high often allowed some of the pressurized air to escape. When the internal pressures were nearly atmospheric, no pressure loss was



Figure 1. Blister that had been instrumented with a pressure sensor (2) and then opened to show the needle position (1).

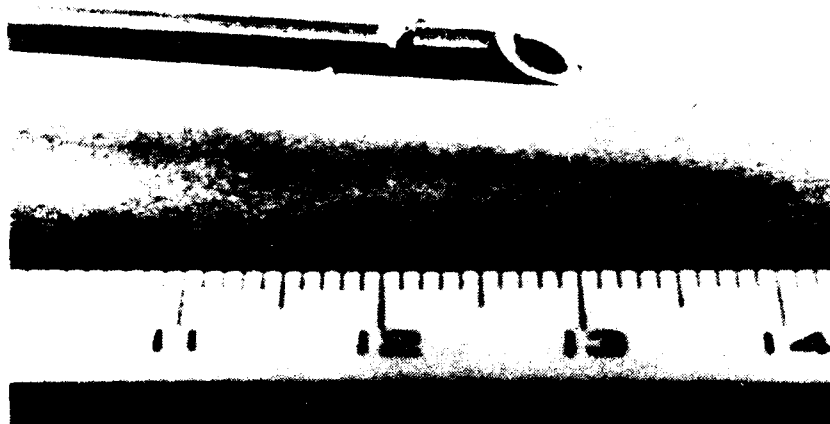

Figure 2. Close-up of the side-vented needle fabricated from 1/8-in. O.D. stainless steel tubing.



Figure 3. Blister instrumented with a pressure transducer (1) and a thermocouple (2).

evident when the needle was inserted. As a safeguard against subsequent leakage the surface bitumen was melted with a small propane torch to form a seal around the needle. A thermocouple was then embedded in the surface bitumen a short distance away from the needle (Fig. 3).

The Blisters

Five blisters on two roofs were measured and instrumented with pressure and temperature sensors. One blister was on the roof of the Vehicle Maintenance Shop (Bldg. 3713) at Fort Devens, Massachusetts. The other four blisters were on the lab-addition roof at CRREL. Table 1 shows the measurements of each blister.

For the Devens blister, the area, length and weight were measured after the blister was removed from the roof and trimmed. Trimming was necessary because the cut edges did not coincide with the actual perimeter. As shown in Figure 4 the cut edge ran both inside and outside of the bond line. The membrane weight shown in Table 1 includes the weight of the surface gravel. The height was determined with the aid of a carpenter's

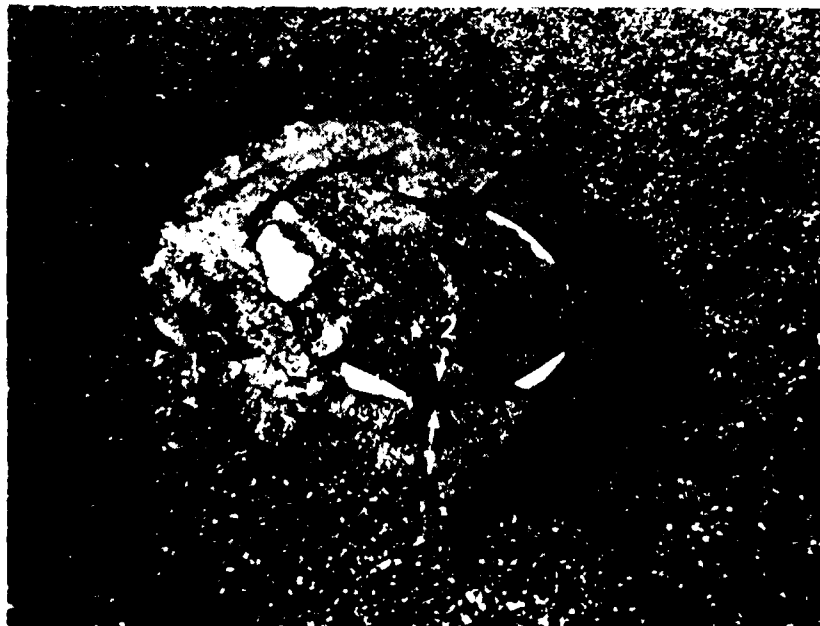

Figure 4. The Devens blister after it was cut. The assumed perimeter (1) did not always coincide with actual perimeter (2).

Table 1. Blister measurements.

Blister	Surface area (in. ²)	Perimeter length (in.)	Height (in.)	Membrane weight (lb)	Slope angle (degrees)	Roof Insulation
Devens	570	81.5	1.9	20.0	9.1	urethane/perlite
CRREL #1	252*	58*	1.5	9*	10.6	urethane/perlite
CRREL #2	365*	74*	1.4	13*	9.8	urethane/perlite
CRREL #3	670*	115*	2.0	23*	14.0	urethane/perlite
CRREL #4	300*	70*	1.6	11*	15.0	urethane/perlite

* estimated

level before the blister was removed from the roof. The slope was calculated from the height and radius of the blister.

Due to inclement weather the CRREL blisters were not removed from the roof. The dimensions were estimated by outlining the shape of each blister with a string and measuring its length to obtain perimeter lengths, and tracing the outline of each blister on a sheet of paper to obtain surface area. The weight was estimated by prorating the weight of the Devens blister to the size of each CRREL blister.

Clues to the origin of the Devens blister are evident on its bottom surface. Figure 5 shows three spots of felt left untouched by bitumen. Eight voids, ranging from 1/16 in. to 5/8 in. in diameter, were noted on the entire blister. These voids probably resulted from poor mopping or brooming practices. Figure 6 shows evidence of foaming (many tiny bubbles), which has been identified in numerous articles as a major cause of blistering over urethane insulation (Roofing/Siding/Insulation 1980a-c, 1982a-d, The Roofing Spec 1981). Together these defects, which were built into the roof, probably caused this blister.

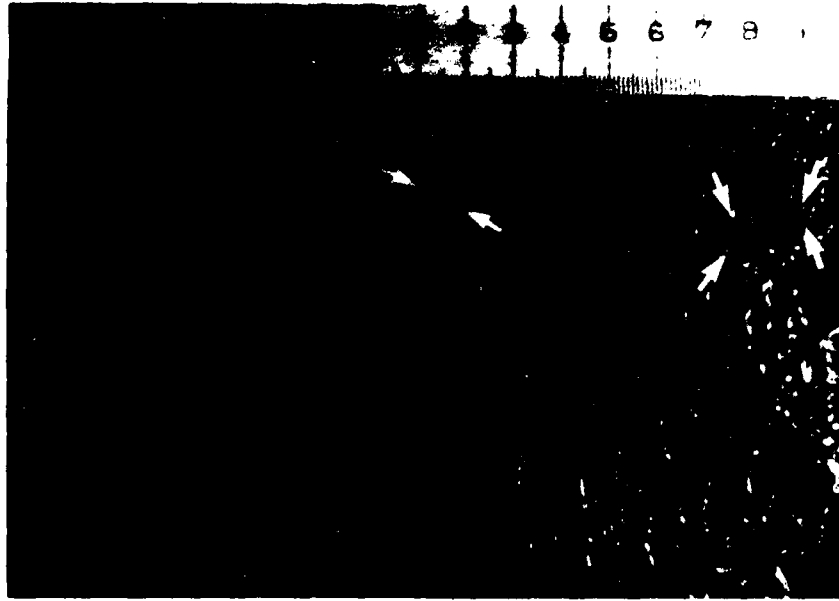

Figure 5. Underside of the Devens blister. The arrows point to mopping voids. Each major division on the scale equals 1 cm.



Figure 6. Evidence of foaming on the Devens blister. The long axis was oriented with the laying direction of the felts. The arrows point to an area of bubbled bitumen.

The blister in Figure 6 was elongated and its long axis was oriented with the laying direction of the felts. I found both circular and elongated blisters at Devens. The elongated ones were generally all oriented in the same direction. I cut into two circular blisters and saw no evidence of a felt lap joint like that in Figure 6. Perhaps felt laps provide a line of weakness along which blisters can expand.

RESULTS

Surface temperatures and internal pressures for each blister are shown in Figures 7-11. As can be seen, changes in roof surface temperature reflect changes in blister pressure. The pressures range from positive (above atmospheric pressure) during the heat of the day to negative (partial vacuum) during the cool of the night. If a blister were completely sealed and rigid, its internal pressures could be determined by referring to Figure 12, which was derived from the ideal gas law.

Comparison with Figures 7-11 shows that measured pressures are significantly less than Figure 12 would suggest. Figure 12 shows, for example, that dry air at 70°F and atmospheric pressure, when elevated to 100°F,

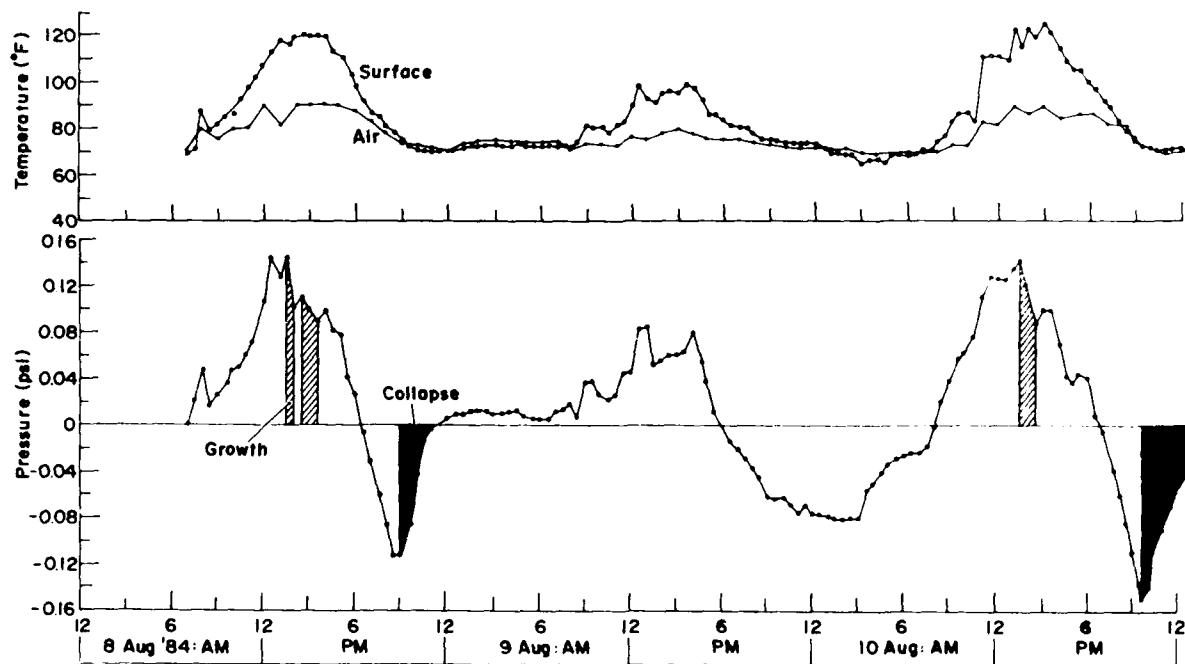

Figure 7. Temperatures and pressures for the Devens blister.

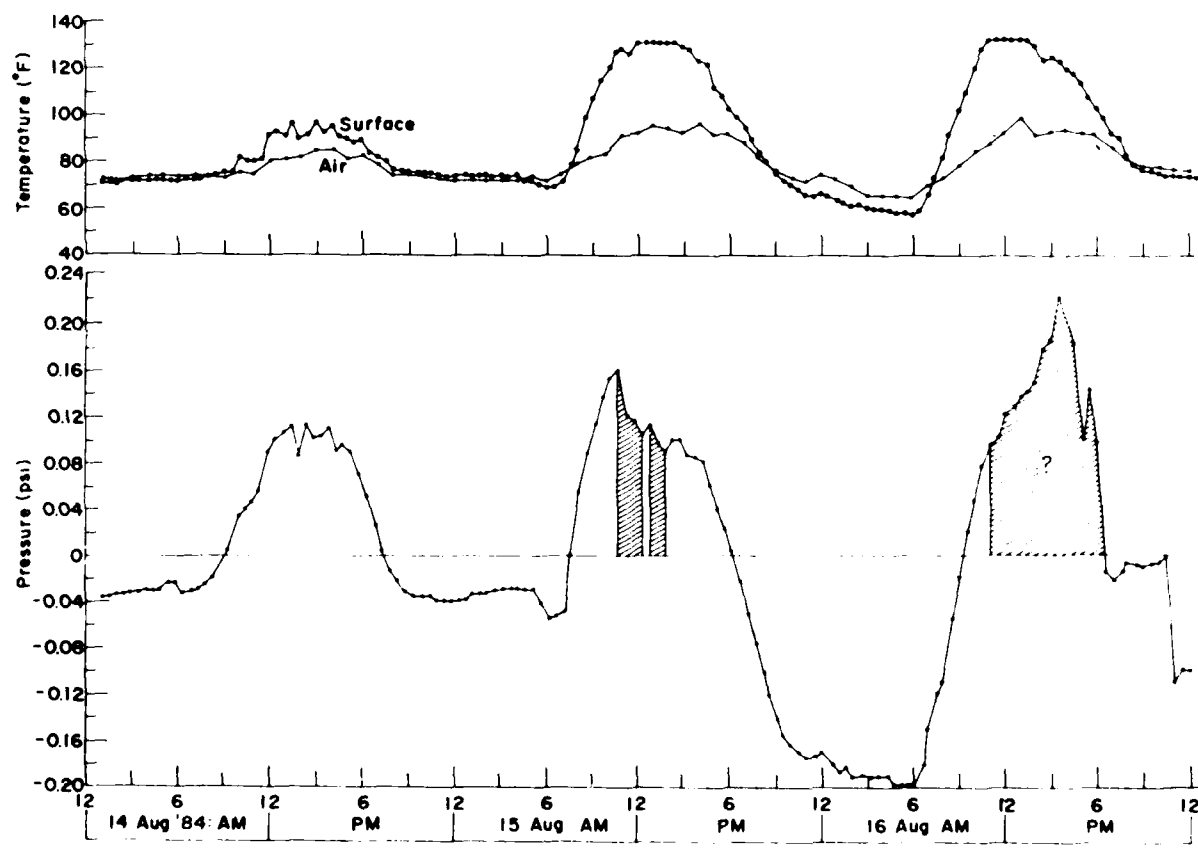
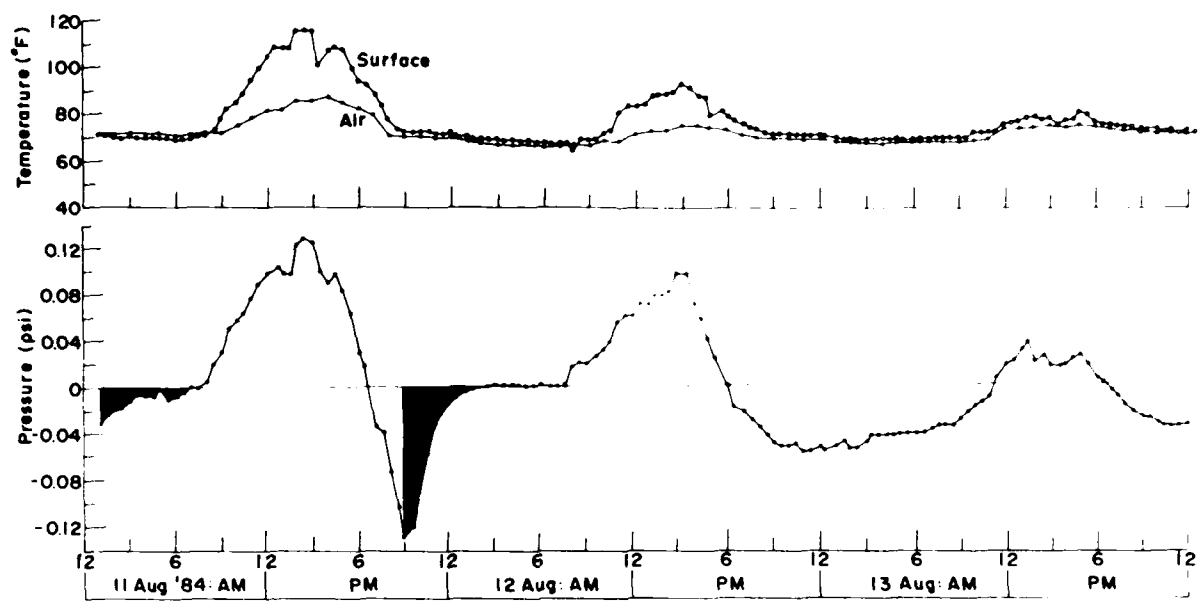

Figure 7 (cont'd). Temperature and pressures for the Devens blister.

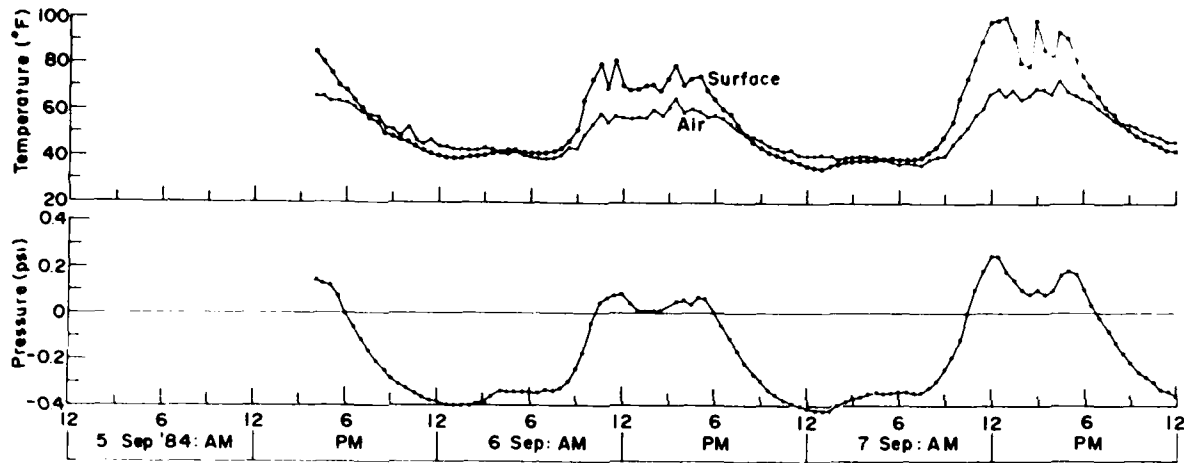

Figure 8. Temperatures and pressures for CRREL blister #1.

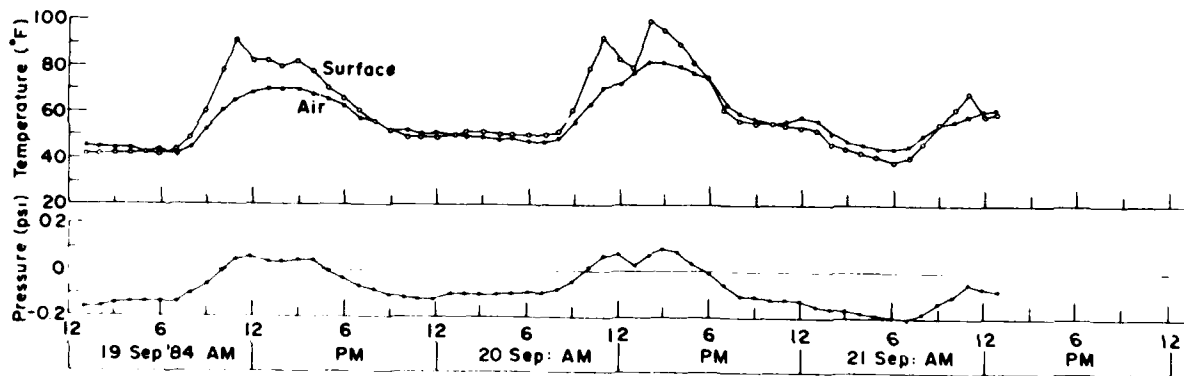
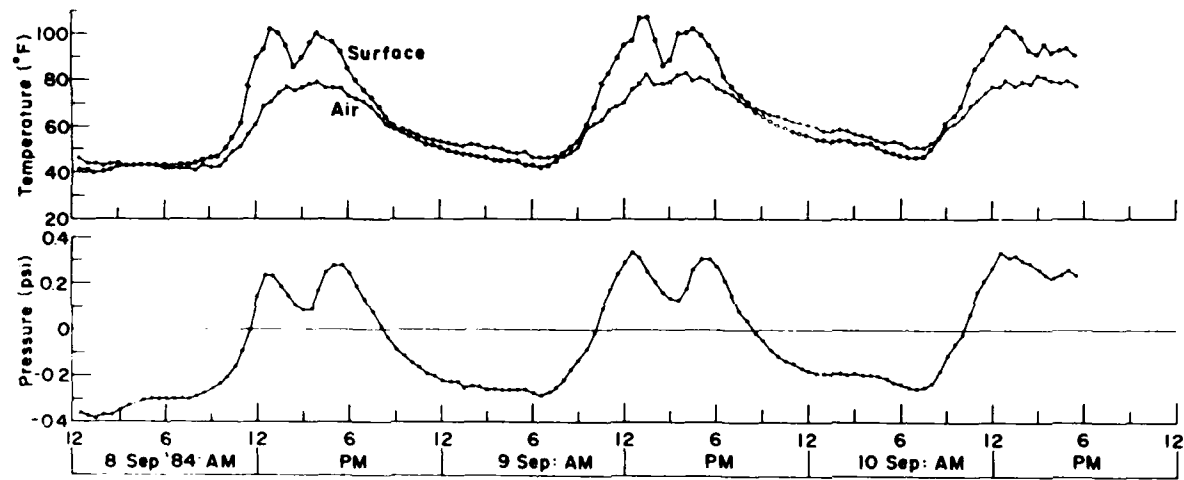

Figure 9. Temperatures and pressures for CRREL blister #2.

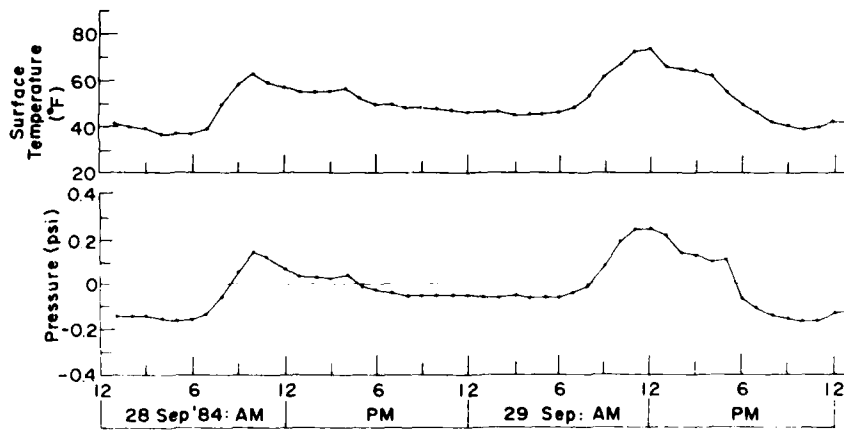
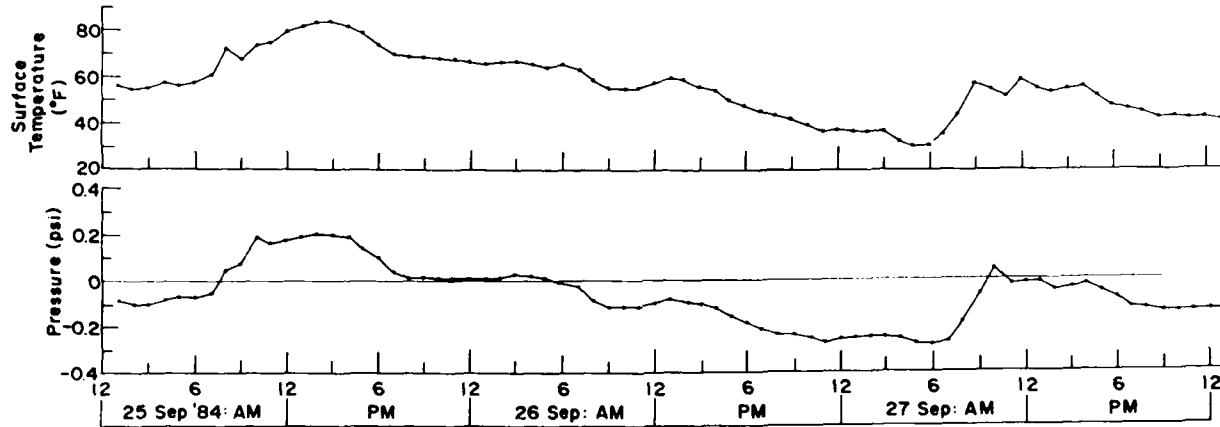
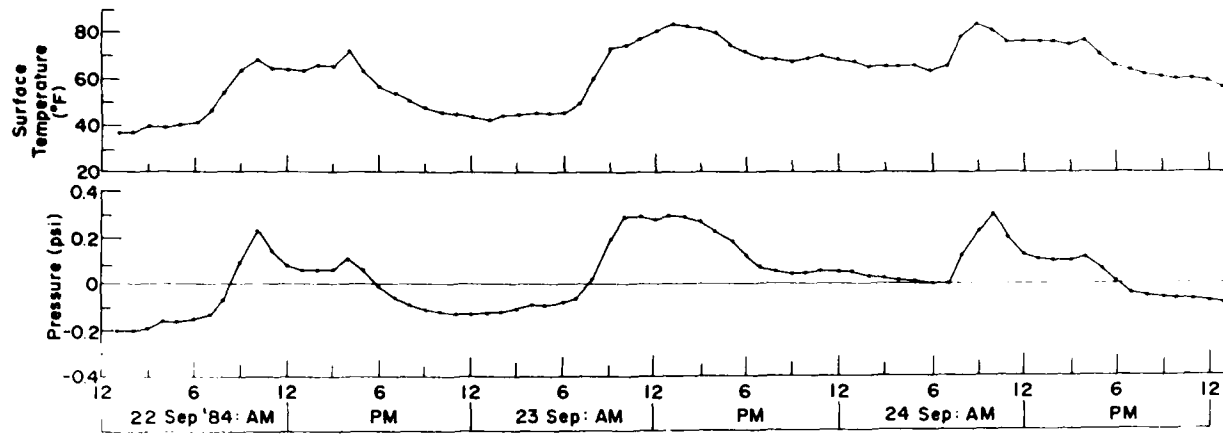

Figure 10. Temperatures and pressures for CRREL blister #3.

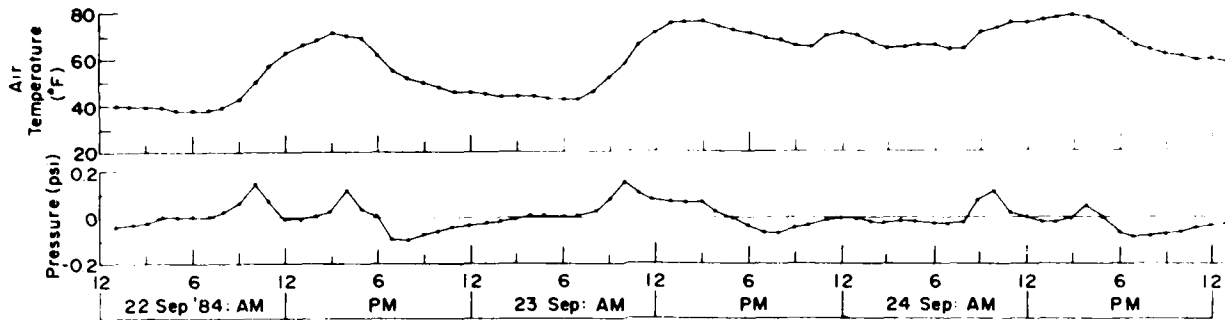

Figure 11. Temperatures and pressures for CRREL blister #4.

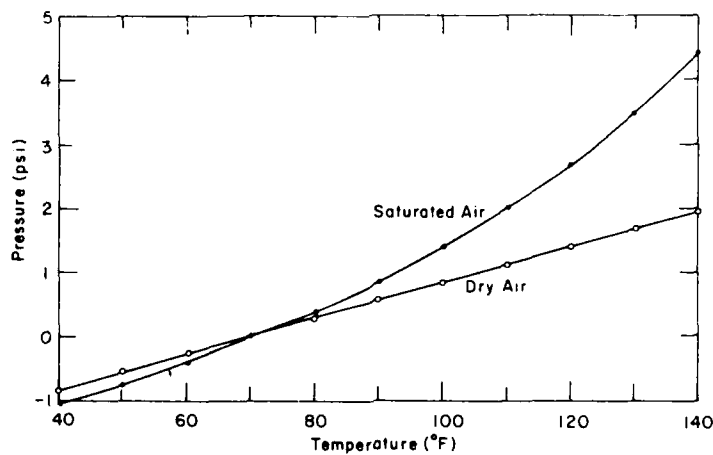
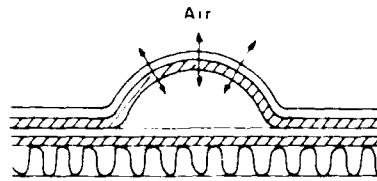

Figure 12. Pressure increases of dry and saturated air.

increases in pressure by 0.8 psi. If that air were saturated with moisture, the pressure increase would be 1.4 psi -- a considerable increase. In comparison, at 11:30 a.m. on 10 August (Fig. 7), the roof surface temperature at Devens was 112°F but the internal blister pressure was only 0.13 psi. Thus, theoretically, dry air alone is all that is required to create these pressures. This lower-than-expected pressure also indicates that air may be slowly escaping from the blister or that the blister may be expanding in volume or both.

Warden (1960) showed that water vapor and oxygen can migrate through a built-up membrane. He felt that a blister, instead of fully containing pressures, could relieve pressure by diffusing gas through its walls. This makes sense in light of my findings. Another and perhaps more likely route of air movement is along the roof felts themselves. Since felts are some-



a. Through membrane.

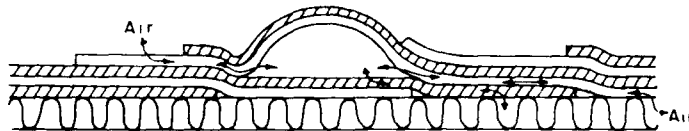

b. Along felts.

Figure 13. Possible air paths.

what porous and are laid on a roof in shingle fashion whereby the top felt eventually becomes the bottom felt, air could find access through microscopic cracks in the flood coat or through mopping voids on the insulation surface (Fig. 13). Since blisters experience positive to negative pressures on a daily basis, it is likely that a blister could breathe in at night and exhale during the day through the routes. If more air were to be drawn in during the vacuum part of the cycle than escapes during the day, then growth would be likely.

Blisters do grow but only under the right temperature and pressure combinations. The optimum conditions do not occur during the hottest part of the summer as might be expected.

Positive Pressures

In over thirty days of field testing I found obvious indications of blister growth on only four days. On 8 August (Fig. 7), for example, the roof surface temperature at Fort Devens rose to a high of 120°F at 2 pm and held there for two hours. The pressure, meanwhile, rose to a high of 0.14 psi at 12:30 pm, dropped to 0.13 psi at 1 pm, and rose again to 0.14 psi at 1:30 pm. At 2 pm, when the surface temperature was still high, the pressure rapidly fell to 0.09 psi. This rapid drop in pressure, when it should have remained high, must be caused by an increase in the volume of the blister, as opposed to a sudden venting. In other words, the blister grew.

The growth patterns were similar on 10, 15 and 16 August. For the remainder of the days (Fig. 7-11) the positive pressures corresponded to changes in surface temperatures: the pressure rose when the temperature rose and fell when the temperature fell. Growth may have occurred during these days as well but my instrumentation was not sensitive enough to detect it. Certainly whatever growth may have occurred was not as dramatic as on the four days mentioned above.

Blisters can grow if the internal pressures can become great enough to cause the roofing felts to deform, by breaking their perimeter bond, by stretching, by slipping over one another, or by a combination of these. Resistance to perimeter uplift results from the weight of the membrane and from the interply bond (peal) strength of the bitumen. Stretching is resisted by the tensile strength of the felt(s). Slipping is resisted by the shear strength of the interply moppings.

Figure 14 shows a force diagram of a blister. The uplift force F_u acting at the perimeter of a blister can be estimated from

$$F_u = \frac{(P A) - W}{L} \quad (1)$$

where

- F_u = uplift force at base (lb/in.)
- P = internal pressure (lb/in.² or psi)
- A_g = surface area (in.²)
- W = weight of roofing (lb)
- L = perimeter (in.).

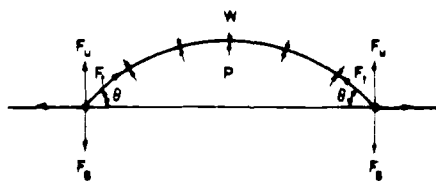

Figure 14. Blister force diagram. F_B , F_u , F_t , P , W and θ are perimeter bond strength, uplift force, tensile force, uplift pressure, membrane weight and slope angle, respectively.

The force tending to stretch the membrane or to cause slipping can be determined from

$$F_t = F_u / \sin\theta \quad (2)$$

where

F_t = tensile force (lb/in.)

F_u = uplift force (lb/in.)

θ = slope of membrane (degrees)

Table 2 lists these forces along with the roof temperature for the four days when growth was evident. The rate of increase in uplift force along the perimeter of each blister just prior to growth (sudden pressure drop) is shown in Figure 15.

Interestingly growth did not occur until the roof temperature reached 118°F (Table 2). At that temperature the blister became soft enough to be deformed by the internally generated forces. The uplift force was 0.73 lb/in. and the tensile force was 4.6 lb/in. Since the minimum tensile strength of an organic felt is 15 lb/in. in the cross-machine direction (ASTM 1981) and the raised portion of the blister resisting this force consisted of the entire four-ply membrane, it is not likely that the felts stretched much. A four-ply membrane should be able to resist at least 60 lb/in. The elongated shape of the blister and the orientation of its long axis along the felt lines indicates that growth was probably accommodated by slipping of the felts or yielding of the bitumen at the perimeter of the blister or both. My measurement techniques were not precise enough to detect which of these modes predominated. However, Griffin (1982) reported

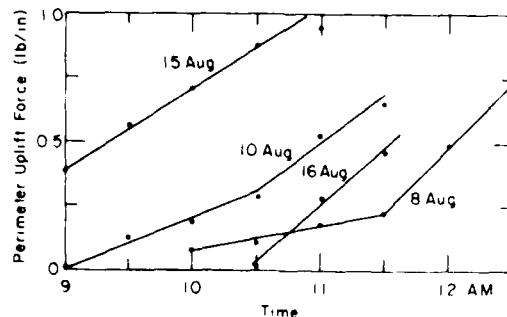

Figure 15. Perimeter uplift force vs time prior to growth.

Table 2. Forces on the Devens blister just prior to growth.

Date	Time	Uplift, F_u (lb/in.)	Tensile, F_t (lb/in.)	Load rate (lb/in. hr)	Membrane temperature (°F)
8 August	1:30 pm	0.73	4.6	0.49	118
10 August	1:30 pm	0.75	4.7	0.38	121
15 August	11:00 am	0.87	5.5	0.35	128
16 August	12:00 noon	0.47	3.0	0.35	132

that steep asphalt at 160°F has a bond strength of 1.0 lb/in., which suggests that the blister could have grown solely by yielding at the perimeter. (More work is needed to define bitumen shear and bond strengths with temperature and load rates to understand growth better.)

Negative Pressures

Nighttime temperatures significantly affect the daytime growth of a blister. During the evenings of 8, 10 and 11 August (Fig. 7) the roof surface temperatures remained at approximately 70°F from 11 pm until morning. The vacuum, instead of also remaining stable, began to rise rapidly shortly before midnight on each night. In these cases the blister walls were not rigid enough to resist the vacuum, so they partially collapsed, as indicated by the rapid pressure change. Collapses such as these inhibit growth the following day by reducing the amount of air that is drawn into a blister at night. For example, on the day following the 10 August collapse, no growth (that is, no sudden drop in pressure) was evident even though the temperatures were sufficiently high.

When nighttime collapses do not occur, on the other hand, the potential for growth is increased. On the evening of 15 August (Fig. 7), for example, the blister vacuum steadily increased as the temperature dropped. No sudden pressure change, indicating a collapse, was evident, so air must have been drawn into the blister all night. Consequently, daytime blister pressures were considerably higher on 16 August than on 15 August even though surface temperatures were essentially the same on each day. Of the four days of growth, the most growth appears to have occurred on 16 August (Fig. 7).

The data show that nighttime collapses occurred only when the nighttime roof surface temperature was above 70°F. No apparent collapses occurred at lower temperatures. Although these relationships may not apply to blisters on other roofs, they do suggest that blisters grow most rapidly when the days are warm and the nights are cool. A series of hot summer days followed by warm evenings are not conducive to blister growth.

Insulation Pressures

To determine whether or not the blisters were caused by pressures within the roof insulation, a pressure sensor needle was inserted into the CRREL roof under a blister. After several days no positive or negative pressures were recorded. Thus it appears that pressures do not occur within the insulated space of a built-up roof, at least not within a board of urethane insulation.

MAINTENANCE TECHNIQUES

One objective of this study was to identify improved maintenance techniques for blisters. I have listed several options below.

Traditional

The current practice is to ignore a blister until its surface begins to erode. Then it is recoated. Once a blister breaks, it is cut open and patched as shown in Figure 16. This approach has met with some degree of success when the blisters are few. It is not, however, feasible to patch a roof covered with blisters. Also, when patching, extreme care must be taken to completely fill each blister with roofing cement to prevent a crop of new blisters caused by entrapped air. The extra roof traffic and disturbance caused by patching blisters is also likely to damage other roof areas that are not problematic.

Reflective Coating

It may be possible to slow the growth rate of a blister by coating its surface with a reflective material. Such a coating would reduce pressures by keeping the blister cooler during the day by reflecting the sun's heat. It would also keep the blister warmer at night by reducing nighttime radiational cooling, making it more susceptible to collapse. Blisters are more likely to collapse when nighttime roof surface temperatures are above 70°F,



a. Blister is x-cut and opened.



b. Felt tabs are trimmed and pressed down once the blister void is filled with roof cement.



c. Several successively large layers of felt and cement are used to patch the cement-filled blister.



d. The final layer of cement is covered with gravel.

Figure 16. One of two traditional methods of patching a ruptured blister. The other way is to completely remove the raised surface before patching.

and collapse inhibits blister growth. If growth could be slowed, then the need for repairs could be postponed a bit longer.

Pressure Relief Valve

Blister growth could be stopped if the pressure is not allowed to build up. If growth could be stopped while a blister is small, then extra

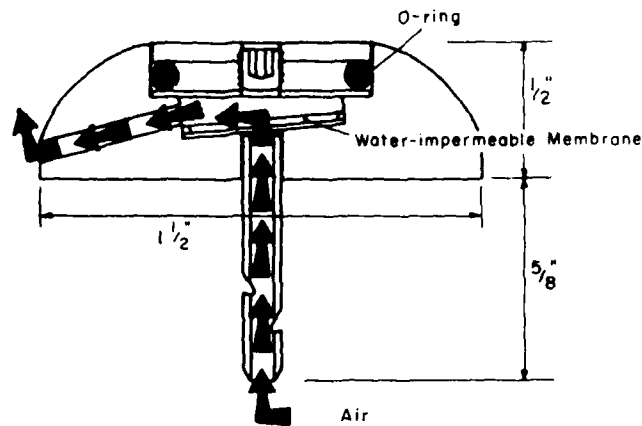

Figure 17. Blister pressure relief valve.

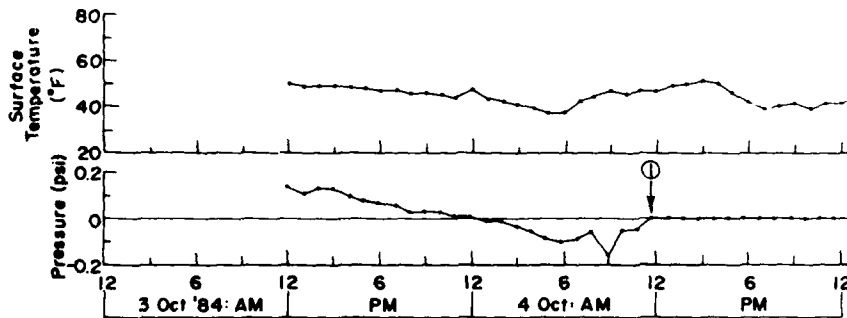

Figure 18. Temperatures and pressures before and after valve was installed (1) into blister.

maintenance might not be required at all. To stop blister growth, I devised a pressure relief valve (Fig. 17). It consists of a membrane, permeable to air but impermeable to liquid water, enclosed in a small housing attached to a needle. I tested this device by inserting the needle into a blister. Figure 18 shows that it worked as planned. No pressure developed after the valve was installed. Because the pressure valve is small, its vulnerability to damage from foot traffic is also small. I walked on it several times on a cool day without dislodging it from the roof. In fact, when it was necessary to remove it, I had to pry it loose with a screwdriver. Although more field testing is needed, these devices appear to have the potential to "kill" blisters when they are small. An application for Army patent rights has been filed.

SUMMARY AND CONCLUSIONS

Blisters are a major problem on built-up roofing systems. To determine their mechanics several blisters were instrumented with pressure and temperature sensors. Blister pressures ranged from positive during the day to negative during the night. The pressures were much smaller than expected, which showed that water is not needed to pressurize a blister and that a blister can breathe. It slowly draws in air at night and allows some of it to escape the next day. Positive and negative pressures develop because the air expands and contracts faster than it can enter or escape from the void. Blisters become bigger with time, making them increasingly more vulnerable to damage.

Reflective coatings may help to slow blister growth. They would reduce daytime surface temperatures and blister pressures and increase nighttime surface temperatures, making a blister more susceptible to collapse. If the blister collapses, then less air is drawn into the blister and growth is inhibited the next day.

Blister growth can be stopped if pressures are eliminated. A pressure relief valve was designed, built, tested and shown to work well at preventing growth. Although more testing is needed, these devices have promise of preventing blisters from becoming maintenance problems.

LITERATURE CITED

ASTM (1981) Standard specification for asphalt-saturated organic felt used in roofing and waterproofing. ASTM D 226-80, in 1981 Annual Book of ASTM Standards, Part 15, American Society for Testing and Materials, Philadelphia, Pa.

Griffin, C. (1982) Manual of Built-Up Roof Systems. Second Edition. New York: McGraw-Hill Inc.

Roof/Siding/Insulation (1980a) Blistering: Still looking for answers. February, pp. 68-71.

Roofing/Siding/Insulation (1980b) NRCA position on blistering over urethane. August, pp. 60-62.

Roofing/Siding/Insulation (1980c) Review, conclusions and discussion of RIC/TIMA testing program. August, pp. 56-58.

Roofing/Siding/Insulation (1982a) TIMA test: BUR is blister free. February, p. 112.

Roofing/Siding/Insulation (1982b) The aging of urethane boardstock. July, pp. 34-41.

Roofing/Siding/Insulation (1982c) RIC/TIMA: Roof a-okay, few problems. July, pp. 44-45.

Roofing/Siding/Insulation (1982d) Blistering controversy rages on. October, pp. 57-62.

The Roofing Spec (1979) The Shape of Roof Construction, November, pp. 38-40.

The Roofing Spec (1981) RIC/TIMA puts roof insulation blistering to the test. January, pp. 55-57.

U.S. Army Corps of Engineers (1974) Facilities engineering maintenance and repair of roofs. Army TM 5-617.

Warden, W. (1960) A theory of the mechanism of blistering: A study to improve bituminous built-up roofs. Building Research Institute, Washington, D.C., Monograph 1.

APPENDIX A: DATA ACQUISITION SYSTEM

The Microswitch model 143PC03D is a high-output, solid-state differential pressure transducer with integrated electronics. It has a ± 2.5 psi range using barometric pressure as a reference. The transducer allows output scaling over a wide range by adjusting the supply voltage. The recommended supply voltage is from 7 to 16 V DC.

An 8.0-V DC supply voltage was selected to produce a transducer output of exactly 1.0 V per psi, with a 3.5-V offset at ambient atmospheric pressure (Fig. A1). A 2-K Ω , 22-turn resistance potentiometer,* connected across the transducer's voltage supply, was adjusted to produce a transducer offset of 0.50 V at atmospheric pressure. This allowed pressures to be read in the range of -0.50 psi to 1.5 with a 0-2.0 V output.

The recording device was an Omnidata Datapod Model DP212. It is one of a series of small solid-state data collection systems that use a programmable read-only memory as the data storage device. The model DP 212 is a two-channel device. Channel one is dedicated to measuring temperature and is usable with a temperature probe available only from Omnidata. Channel two is usable with a temperature probe or can be used to record voltage in the range of 0-2.0 V; this option can be selected with an internal switch.

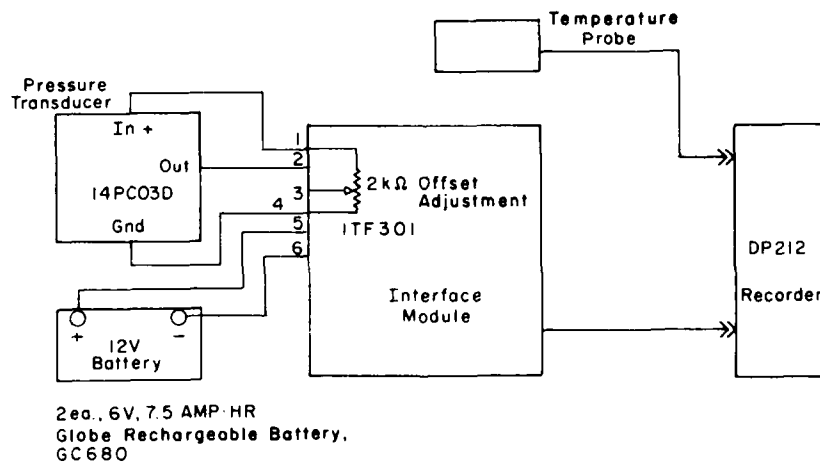

Figure A1. Data acquisition system.

* The potentiometer was placed inside the case of the Interface Module. Should the Interface Module be used in another application, this modification must be removed.

The DP212 was used with an Omnidata Model 1TF301 Interface Module. The transducer was directly connected to a terminal strip on the interface module. An external 12-V battery was connected to the terminal strip also. An adjustable voltage regulator contained in the interface module supplied the 8.0 V required for pressure transducer excitation. The module also contained a voltage divider so that the transducer output could be matched to the 0-2.0 V range expected by the Datapod. (The user must refer to the 1TF301 Interface Module manual for these range and voltage adjustments.) The pressure transducer was powered only on demand by the Datapod, which controlled a relay in the Interface Module. The transducer was excited just prior to recording data to conserve battery power. (The rate of data collection is user programmable with an internal switch bank, explained in the user manual for the Datapod Model DP212.)

Both the Interface Module and the Datapod are sealed with rubber gaskets, leaving only the terminal strip and external battery terminals exposed. This provided environmental protection.

☆ U.S. GOVERNMENT PRINTING OFFICE: 1987-700-050/62011

END

DATE

FILMED

4-88

DTIC