

AD-A185 001

DATA BASE ACQUISITION FOR MULTIPLE-SENSOR PROCESSING  
(U) ARMY ENGINEER WATERWAYS EXPERIMENT STATION  
VICKSBURG MS ENVIRONMENTAL LAB J C DUKE AUG 87

1/1

UNCLASSIFIED

MES/TR/EL-87-10

F/G 17/6

NL

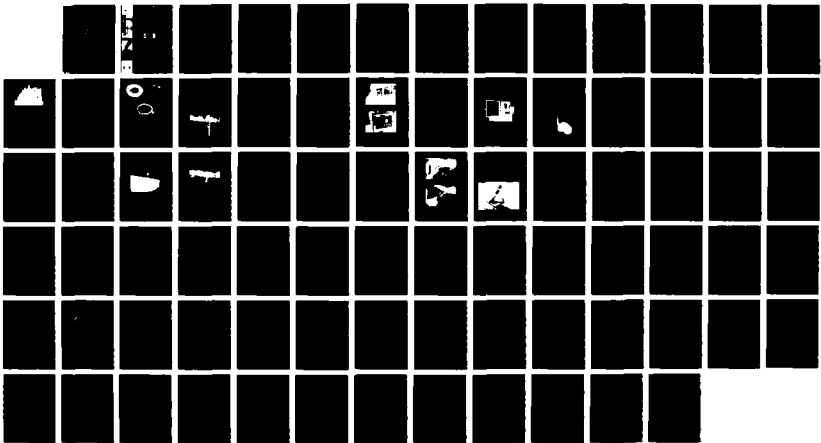

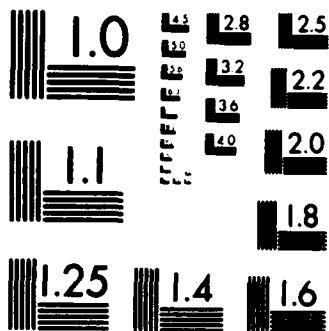

MICROCOPY RESOLUTION TEST CHART  
NATIONAL BUREAU OF STANDARDS 1963 A

DTIC FILE COPY

2

TECHNICAL REPORT EL-87-10

# DATA BASE ACQUISITION FOR MULTIPLE-SENSOR PROCESSING

by

Jonathan C. Duke, Jr.

Environmental Laboratory

DEPARTMENT OF THE ARMY  
Waterways Experiment Station, Corps of Engineers  
PO Box 631, Vicksburg, Mississippi 39180-0631

DTIC  
ELECTE  
SEP 25 1987  
S D



August 1987  
Final Report

Approved For Public Release. Distribution Unlimited

Prepared for Defense Nuclear Agency  
Washington, DC 20305

87 9 18 081



US Army Corps  
of Engineers

AD-A185 001



ADA185001

REPORT DOCUMENTATION PAGE				Form Approved OMB No 0704-0188 Exp Date Jun 30, 1986	
1a. REPORT SECURITY CLASSIFICATION Unclassified			1b. RESTRICTIVE MARKINGS		
2a. SECURITY CLASSIFICATION AUTHORITY			3. DISTRIBUTION / AVAILABILITY OF REPORT		
2b. DECLASSIFICATION / DOWNGRADING SCHEDULE			Approved for public release; distribution unlimited.		
4. PERFORMING ORGANIZATION REPORT NUMBER(S) Technical Report EL-87-10			5. MONITORING ORGANIZATION REPORT NUMBER(S)		
6a. NAME OF PERFORMING ORGANIZATION USAEWES Environmental Laboratory		6b. OFFICE SYMBOL (if applicable) WESEN-B	7a. NAME OF MONITORING ORGANIZATION		
6c. ADDRESS (City, State, and ZIP Code) PO Box 631 Vicksburg, MS 39180-0631			7b. ADDRESS (City, State, and ZIP Code)		
8a. NAME OF FUNDING / SPONSORING ORGANIZATION Defense Nuclear Agency		8b. OFFICE SYMBOL (if applicable)	9. PROCUREMENT INSTRUMENT IDENTIFICATION NUMBER		
8c. ADDRESS (City, State, and ZIP Code) Washington, DC 20305			10. SOURCE OF FUNDING NUMBERS		
			PROGRAM ELEMENT NO.	PROJECT NO.	TASK NO.
			WORK UNIT ACCESSION NO.		
11. TITLE (Include Security Classification) Data Base Acquisition for Multiple-Sensor Processing					
12. PERSONAL AUTHOR(S) Duke, Jonathan C., Jr.					
13a. TYPE OF REPORT Final report		13b. TIME COVERED FROM _____ TO _____		14. DATE OF REPORT (Year, Month, Day) August 1987	15. PAGE COUNT 77
16. SUPPLEMENTARY NOTATION Available from National Technical Information Service, 5285 Port Royal Road, Springfield, VA 22161.					
17. COSATI CODES		18. SUBJECT TERMS (Continue on reverse if necessary and identify by block number)			
FIELD	GROUP	SUB-GROUP	Electronic intrusion detection Security systems		
			Intrusion detection Seismic detection		
			Microwave sensor Transducer cable		
19. ABSTRACT (Continue on reverse if necessary and identify by block number) → This study was conducted to develop a data base of multiple-sensor perimeter security system response signatures to a variety of environmental and intrusion conditions. Six different perimeter security systems were installed at two locations: a temperate climate test facility and a northern latitude test site. The responses of the installed systems to intrusions, changing environmental conditions, and nuisance noise sources were recorded using 32-track analog recording equipment. This report describes the security systems, the environmental constraints of each system, the testing program, the instrumentation developed, the recording techniques, and the multiple-sensor data base developed.					
20. DISTRIBUTION / AVAILABILITY OF ABSTRACT <input checked="" type="checkbox"/> UNCLASSIFIED/UNLIMITED <input type="checkbox"/> SAME AS RPT <input type="checkbox"/> DTIC USERS			21. ABSTRACT SECURITY CLASSIFICATION Unclassified		
22a. NAME OF RESPONSIBLE INDIVIDUAL			22b. TELEPHONE (Include Area Code)		22c. OFFICE SYMBOL

## SUMMARY

A data base of multiple-sensor security system signatures was collected for the purpose of training an adaptive learning network being developed by the General Research Corporation under contract to the Defense Nuclear Agency.

Techniques were developed to allow accurate, efficient analog recording of multiple-sensor security systems' response to various environmental and intrusion conditions. These techniques, coupled with installation in a temperature climate multiple-sensor test facility (US Army Engineer Waterways Experiment Station, Vicksburg, MS) and a cold climate test site (Cold Regions Research and Engineering Laboratory, Hanover, NH), allowed the collection of more than 1,700 signature tests: 700 temperature climate controlled tests, 500 frozen soil controlled tests, and more than 500 summer tests at the frozen soil site.

In addition, records of more than 200 uncontrolled tests made during adverse weather conditions were collected at the multiple-sensor test site. A need for the development of specialized meteorological equipment and advanced data collection techniques identified in earlier research with sensor systems and was verified during this study. To satisfy the needs for meteorologically supportive data, a lightning detection system was designed and analog anemometers were installed on the system. The need for a high-speed digital data acquisition computer was identified.



Accession For	
NTIS CRA&I	<input checked="" type="checkbox"/>
DTIC TAB	<input type="checkbox"/>
Unannounced	<input type="checkbox"/>
Justification	
By	
Distribution /	
Availability Codes	
Dist	Availability or Special
<b>A-1</b>	

## PREFACE

This study was conducted by personnel of the Environmental Laboratory (EL), US Army Engineer Waterways Experiment Station (WES), during the period May 1983 through June 1985, as part of an overall program of support to the Defense Nuclear Agency (DNA), under Military Intradepartmental Purchase Request Nos. 84-505 and 85-510. Technical Managers for the study were LTC Ray Bitler, MAJ George Flowers (P), and MAJ Keith Weber, DNA. This report describes the results obtained in a program to provide a data base of multiple-sensor security system responses for varying environmental and intrusion conditions.

The study was conducted under the general supervision of Dr. John Harrison, Chief, EL, and Mr. Bob O. Benn and Dr. Lewis E. Link, former Chief and Chief, respectively, Environmental Systems Division, EL, and under the direct supervision of Mr. Jerry R. Lundien, Chief, Battlefield Environment Group (BEG), EL.

This report was prepared by Mr. Jonathan C. Duke, Jr., of the BEG. Project Manager was Mr. Charles A. Miller, BEG. Acknowledgment is made to Messrs. Monroe B. Savage and David Daily, Instrumentation Services Division, WES, who designed, constructed, and operated the specialized instrumentation and interfacing required to support this study. The report was edited by Ms. Jessica S. Ruff of the WES Information Products Division.

COL Allen F. Grum, USA, was the previous Director of WES. COL Dwayne G. Lee, CE, is the present Commander and Director. Dr. Robert W. Whalin is Technical Director.

This report should be cited as follows:

Duke, Jonathan C., Jr. 1986. "Data Base Acquisition for Multiple-Sensor Processing," Technical Report EL-87-10, US Army Engineer Waterways Experiment Station, Vicksburg, Miss.

## TABLE OF CONTENTS

<u>Section</u>		<u>Page</u>
	SUMMARY .....	iii
	PREFACE .....	iv
	LIST OF TABLES .....	vi
	LIST OF ILLUSTRATIONS .....	vi
1	INTRODUCTION .....	1
	1.1 BACKGROUND .....	1
	1.2 PURPOSE AND SCOPE .....	4
2	SENSOR SYSTEMS/INSTRUMENTATION AND SUPPORT EQUIPMENT/INSTRUMENTATION .....	6
	2.1 SENSOR SYSTEMS .....	6
	2.2 RECORDING INSTRUMENTATION .....	18
	2.3 SUPPORTIVE EQUIPMENT AND INSTRUMENTATION .....	22
3	SITE DESCRIPTION AND TEST PROGRAM .....	29
	3.1 TEST SITES .....	29
	3.2 SENSOR INSTALLATION .....	34
	3.3 TEST PROGRAM .....	37
4	PRESENTATION OF DATA .....	41
	4.1 DATA BASE AND DATA BASE HANDLING .....	41
	4.2 DATA PRESENTATION .....	41
5	CONCLUSIONS AND RECOMMENDATIONS .....	69
	5.1 CONCLUSIONS .....	69
	5.2 RECOMMENDATIONS .....	70
	REFERENCES .....	71

## LIST OF TABLES

<u>Table</u>		<u>Page</u>
1	Abbreviated log of WES testing .....	51
2	Abbreviated log of CRREL testing .....	58

## LIST OF ILLUSTRATIONS

<u>Figure</u>		<u>Page</u>
1	MAID processor .....	7
2	Components of Honeywell BLS-1000 system .....	9
3	Sylvania FPS-2 processor .....	10
4	Sentrax System modules .....	13
5	Single-zone E-field system controller .....	15
6	Post-mounted Racon 14000 transmitter .....	16
7	Block diagram of signal flow .....	20
8	B&K outdoor microphone .....	23
9	Campbell meteorological station .....	24
10	Calibrated creeper .....	26
11	Fence drop hammer, used to measure response of FPS .....	28
12	Aerial photograph of WES multiple-sensor test facility .....	29
13	Diagram of WES multiple-sensor test facility .....	31
14	Diagram of CRREL multiple-sensor test site .....	33
15	Sentrax sensor signature and alarm response plots .....	43
16	Racon sensor signature and alarm response plots .....	44
17	Racon sensor signature and alarm response plots .....	45
18	BLS sensor signature and electronic module alarm response plots .....	47
19	E-field sensor signature and alarm response plots .....	48
20	FPS sensor signature and alarm response plots .....	49
21	Geophone responses to intrusions .....	50



# DATA BASE ACQUISITION FOR MULTIPLE-SENSOR PROCESSING

## SECTION 1

### INTRODUCTION

#### 1.1 BACKGROUND.

A primary design consideration for perimeter security intrusion detection systems is the maintenance of the appropriate sensitivity levels both to achieve a high probability of target detection and to reduce the probability of false alarms from nuisance and background sources. Since the sensitivity of a system varies according to specific physical environmental factors, no consistent optimum sensitivity level can be specified for a particular type of sensing task. Thus, the optimum sensitivity level of a sensor type may vary from site to site and from season to season at any one site (Benn and Link 1972; Link, West, and Benn 1972; Marcuson and Leach 1973).

The phenomenon by which a system detects intrusions dictates the physical environmental factors and the types of background/nuisance sources that affect the overall detection capabilities (performance) of the system. In some cases, changes in environmental factors that cause a decrease in sensitivity in one sensor type may cause increased sensitivity in another (Benn and Smith 1975).

In view of the above factors, security system developers have investigated perimeter security designs that employ multiple sensors that exploit more than one sensing phenomenon. For the most part, this work has focused on combination-of-alarm processing (assessment of alarm data only) and, therefore, is somewhat limited. New concepts involving multiple-channel high-throughput signal processing make possible the development of capabilities involving at-the-sensor preprocessing such as coherence and correlation processing of sensor signals from more than one type of sensor and for more than one detection zone. This higher level correlative processing can aid in reducing background and nuisance alarms, which increases the probability-of-detection capabilities of the total system.

Intrusion detection system sensors are of two basic types: active and passive. Active systems modify their environment in some manner, usually by means of a system-generated signal such as radio frequency waves. Passive

systems use transducers to measure changes in some environmental parameter; an example is the magnetostrictive buried-line transducer. Generally, intrusion detection sensors measure only one environmental parameter to determine the absence or presence of an intruder within the sensor's detection zone. The use of multiple-sensor systems with each sensor using different principles of detection increases the possibility of intruder detection and reduces the nuisance alarm rate if signals from the sensor systems are properly processed.

Although a great deal of data have been obtained under various test and field conditions for individual sensor systems (Cress 1978, Miller 1978, Zappi 1978, and Miller 1979), little work has been done to develop a data base of sensor signatures and sensor alarms from multiple-sensor security systems (i.e., except for the limited work in processing of the combination-of-alarm data mentioned above).

It is unlikely that the processing of alarm data from multiple security systems without considering sensor transducer signatures can provide an acceptable nuisance/false alarm rate (NAR/FAR) for several reasons. Most security systems do not have adequate signal conditioning to compensate for the dynamics of the environment, nor do most systems allow for environmental changes in the feedback loop other than through user recalibration. Also, combinational processing of alarm data alone does not allow for the dynamic weighting of intrusion data that can be allowed for with transducer signals.

To achieve the advantages that a multiple-sensor security system can offer (i.e., increased probability of detection with a reduction in the NAR/FAR), five primary topics must be addressed:

- a. Families of security systems (methods of detection).
- b. Environmental factors that affect the response of the security systems.
- c. Alarm data.
- d. Transducer signatures.
- e. Methods of intrusion.

Remembering that perimeter security systems either measure some change in their environment or measure the change in some condition imposed on the environment, one can readily see the importance of quantifying the response of sensor systems to environmental changes, both the changes that occur naturally and those that occur as the result of an intrusion. Changes in the environment of a sensor generally produce sensitivity and variability changes

resulting in the alteration of detection reliability. This alteration of detection sensitivities can cause changes in the probability of detection with subsequent changes in the NAR/FAR. A change in sensor performance can occur over a period of seconds, hours, or months, depending upon many natural or man-induced changes in the sensor's environment (Cress 1978, Miller and Ballard 1981).

With multiple-sensor security systems, the environment has varying effects on each of a system's sensors, with all changes in the environment affecting each system simultaneously or nearly simultaneously. Although some of the systems may not be sensitive to a specific environmental change, some environmental changes can affect all of the systems, with some systems being more affected than others. Under optimum conditions, the penetration of a zone of detection might be classified as an intrusion by all systems monitoring the zone. However, in less-than-optimum conditions, the sensors may detect the presence of an intruder but not to the degree required to register a violation as an intrusion.

Because of the many environmental and security system variables associated with multiple-sensor perimeter security systems, combined with the environmental changes (including intrusions) that may affect each sensor within a zone differently, development of integrated multiple-sensor monitoring systems requires a data base of intrusion events occurring under a variety of environmental conditions. Both the responses of the system controller's alarms and the signatures generated by the individual transducers that measure environmental responses within the security zones are important components.

For a data base to be of maximum utility for designing and testing multiple-sensor security systems, it must contain a wide variety of environmental and noise backgrounds and deliberate and incidental intruder signatures representative of the intrusion techniques that a multiple-sensor system would be required to detect.

Because many environmental conditions that induce nuisance alarms cannot be controlled or generated on command and occur only on an intermittent basis, provisions must be made for security system designers and researchers to access a repository of nuisance alarm data. The alarm-triggering event and any precursor events must be recorded for adequate definition of the event. To capture a complete nuisance-alarm triggering event signature requires special high-speed digital recording equipment and special software to identify these conditions.

Because of the US Army Engineer Waterways Experiment Station (WES) extensive research of microwave, seismic, and acoustic wave propagation, descriptive and predictive modeling, and classification in a wide variety of environmental mediums, and its close association with the development and testing of the US Army's REMBASS sensor technology (an adaptive learning system), WES was requested by the Defense Nuclear Agency to provide assistance in the development, collection, and analysis of a multiple-sensor data base.

## 1.2 PURPOSE AND SCOPE.

### 1.2.1 Purpose.

The study described herein was conducted with the following objectives:

a. Develop a data base of sensor and alarm signatures that are representative of those that might be expected in temperate and frozen-soil conditions for typical perimeter security systems under a variety of environmental noises and intrusion techniques.

b. Develop instrumentation for efficient recording, monitoring, and cataloging of sensor signatures gained during multiple-sensor testing.

c. Identify the hardware necessary to catalog the data base of intrusion and nuisance tests (controlled and uncontrolled tests) into a matrix, thus allowing rapid and efficient retrieval of categories of events for systems testing and emulation as well as for software and hardware development.

d. Develop a data-acquisition system with complete sensor signature (i.e., prealarm, alarm, and postalarm) collection capabilities.

e. Identify the computer hardware and identify an operating system that would allow testing of the applicability of various processing techniques on representative data sets to determine the technique's utility in increasing the probability of detection and reducing the incidence of nuisance/false alarms. The analytical techniques such a system must be capable of evaluating included:

(1) Correlation and coherence for various types of detection sensors in a single zone.

(2) Correlation and coherence for similar types of detection sensor types in adjacent zones.

(3) Time correlation between detection, environmental, and other nondetection sensor types.

- (4) Combination-of-alarm analysis.
- (5) Variation of sensor response with time-dependent changes in environmental conditions.
- (6) Digital filtering and digital analysis techniques.

#### 1.2.2 Scope.

Section 2 provides a description of the families of security systems considered, the sensor systems tested, the environmental factors that affect the systems used to develop a data base, the instrumentation techniques used to develop a data base, and special testing devices developed or utilized to provide standard target responses or to allow for uniform tests under various environmental conditions.

Section 3 describes the test sites, sensor installations, methods of intrusion, and the test program. Section 4 presents a qualitative analysis of several representative tests, including transducer signatures and the associated alarm data. Section 5 summarizes the study conclusions and recommendations.

## SECTION 2

### SENSOR SYSTEMS/INSTRUMENTATION AND SUPPORT EQUIPMENT/INSTRUMENTATION

#### 2.1 SENSOR SYSTEMS.

The six security sensor systems deployed for the study described herein included active and passive systems, briefly described below.

##### a. Passive.

(1) MAID processor/MILES cable military magnetostrictive line sensor, which uses a single conductor winding with directional reversal at regular intervals.

(2) Honeywell Buried-Line Sensor (Model BLS 1000), a commercial magnetostrictive line sensor that uses two counter-wrapped conductor windings.

(3) Sylvania Fence Protection System (Model FPS-2), a fence disturbance sensor.

##### b. Active.

(1) Senstar Sentrax Buried Line Perimeter Intrusion Detection System (Sentrax), a buried leaky coaxial cable that leaks radio waves from the transmitter to the receiver.

(2) Stellar System E-field Perimeter Protection System, a fence-mounted electrostatic system that consists of field and sense wires that sense a change in the environment near the wires.

(3) Racon Series 14000 Microwave Fence Sensor bistatic microwave intrusion detection system.

The Racon and MILES sensors were installed according to Siting Criteria for SAFE Programs. The remaining security systems were installed using the manufacturer's installation procedure recommended for the highest probability of detection.

#### 2.1.1 Passive Systems.

2.1.1.1 MAID/MILES. The AN/GSS-26(A) MAID/MILES (Magnetic Anti-Intrusion Detector/Magnetic Intrusion Line Sensor) alarm set consists of two basic components: a MAID processor (Figure 1) and a MILES magnetostrictive sensor cable. The MAID/MILES generates an alarm signal if a local disturbance in the earth's magnetic field is produced by movements of a ferrous material over or near the transducer cable, or in response to minute cable displacements in the

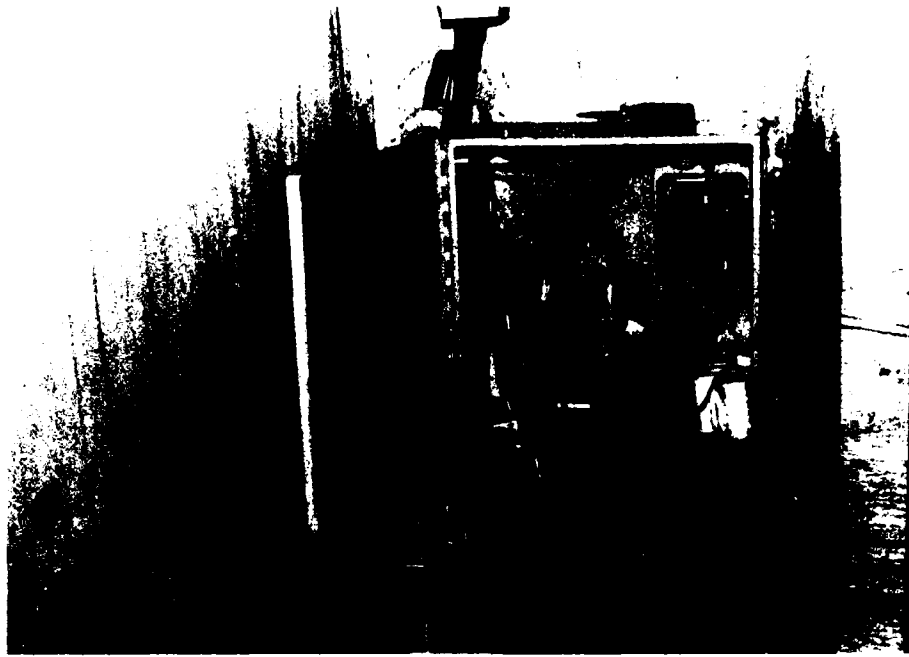

Figure 1. MAID processor.

seismic environment. The MAID/MILES alarm set is presently the primary perimeter line sensor for the SAFE program. The following description of the MILES cable was taken from Starr (1976).

The MILES cable is a shielded coaxial cable with an inner core of stranded heavy gauge Permaloy wire having magnetostrictive properties. Surrounding the core is a continuous coil of copper wire which is electrically insulated from the core and the outside shielding. During operation, an electrical current is induced in the coil of the wire due to either tension loading of the cable which causes a change in the magnetic flux of the core or by changes in magnetic fields external to the cable. The tension loading of the cable is caused by transient displacements in the media (soil) surrounding the cable. As an intruder travels in the vicinity of the cable, each footstep generates soil displacements radiating away from the foot in all directions in the ground. One component of these displacements will produce a transient tension loading on the cable. To suppress the response of the cable to background seismic (and electrical) energy, the direction of the sensing winding is reversed at regular intervals. These transpositions have a typical spacing of 1.05 meters. Previous studies have shown that within the frequency limits of the MAID processor (i.e. less than 5 Hz) the transducer output is dependent on the frequency and amplitude of the tension loading on the cable.

A descriptive analysis of the seismic response of the MILES sensor as a function of (a) the properties (shear and compression moduli) of the burial medium, (b) depth of burial, (c) the backfill material, and (d) the magnetic history was conducted by Cress (1978).

The MILES cable is responsive to both seismic and electromagnetic energies, and many possible sources of noise are potentially troublesome for users. The SAFE siting criteria provide installation guidance and siting considerations that also take into account the environmental constraints upon the MAID/MILES system. These considerations include many sources of seismic signals and electrical/electronic noises. Among the limitations and siting considerations given in the "Siting Criteria for SAFE Programs" (SAFE-SIT-0001) are:

- a. Proximity and alignment with perimeter fencing.
- b. Fence crossings.
- c. MILES end effect.
- d. Electrical and moving equipment.
- e. Power distribution systems.
- f. Nonelectrical infrastructure (e.g., facility sewerage, storm drainages) that can generate low-frequency seismic signals.

More detailed analysis of these siting considerations is provided in SAFE-SIT-0001.

2.1.1.2 Honeywell BLS. The BLS buried-line sensor (Honeywell 1979) consists of a transducer cable, an electronic module, and a power/alarm cable assembly (Figure 2).

The BLS functions similarly to the MAID/MILES system, and the sensor cable of the BLS can be easily interfaced to the MAID processor. As with the MAID/MILES system, it was the response of the buried-line transducer and not the signal-processing package (electronics module or MAID processor) that was of primary concern in this study, although the sensor's processor alarm was also recorded.

The following description of the BLS was taken from the manufacturer's publication "BLS-1000 Technical Data and Installation Instructions."

The transducer cable, a flexible assembly approximately 1 inch (25 mm) wide by 3/8 inch (10 mm) thick, is jacketed with an extruded plastic material which provides excellent moisture resistance. Under this jacket, stainless steel tape is wrapped to provide rejection of EMI



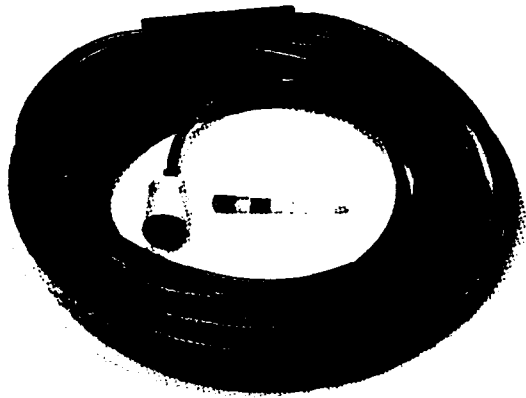

a. Transducer cable.



b. Electronic module.

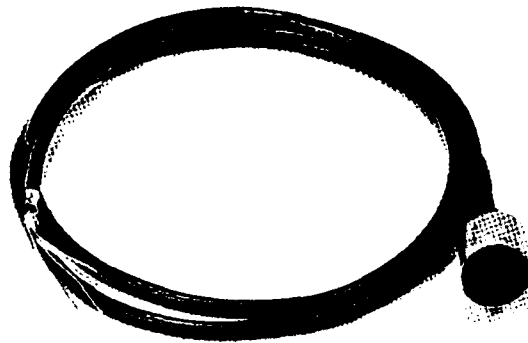

c. Power/alarm cable assembly.

Figure 2. Components of Honeywell BLS-1000 system.

(electromagnetic interference) and to provide protection from rodents. The BLS-1000 transducer cable is designed to reject many potential nuisance alarms by utilizing a gradiometer construction which significantly reduces effects of farfield disturbances.

The deployment considerations and limitations of the BLS are similar to those of the MAID/MILES and differ significantly only in degree or magnitude. One employment limitation of the BLS that has not been determined to exist with the MAID/MILES is that of transducer orientation. The BLS siting criteria for cable orientation are quoted as follows.

The transducer cable must be installed in such a manner that a (magnetic) direction reversal does not occur at the north end or south end of a site. This requirement is necessary because a single cable (zone) must be magnetized in the same direction as the earth's magnetic field.

The BLS's installation requirement for geomagnetic orientation is due to the method used by the BLS to magnetize its core. The BLS can be magnetized remotely (at the cable connector) by applying a voltage source to the coils surrounding its core. This method is much easier than magnetization of the MILES cable because the MILES must have an external field applied to the cable.

2.1.1.3 Sylvania Fence Protection System. The third passive intrusion detection system employed in the testing program was the Sylvania Model FPS-2 (Sylvania (GTE), Inc. 1978). The two basic components of the FPS are a sensor cable and a signal processor (Figure 3). The FPS uses a noisy coaxial cable that senses the vibrations of chain-link fencing. The fence vibrations, converted into high-frequency, amplitude-modulated bursts, are analyzed in the processor unit for frequency and amplitude content to detect the presence of an intruder on the fence.

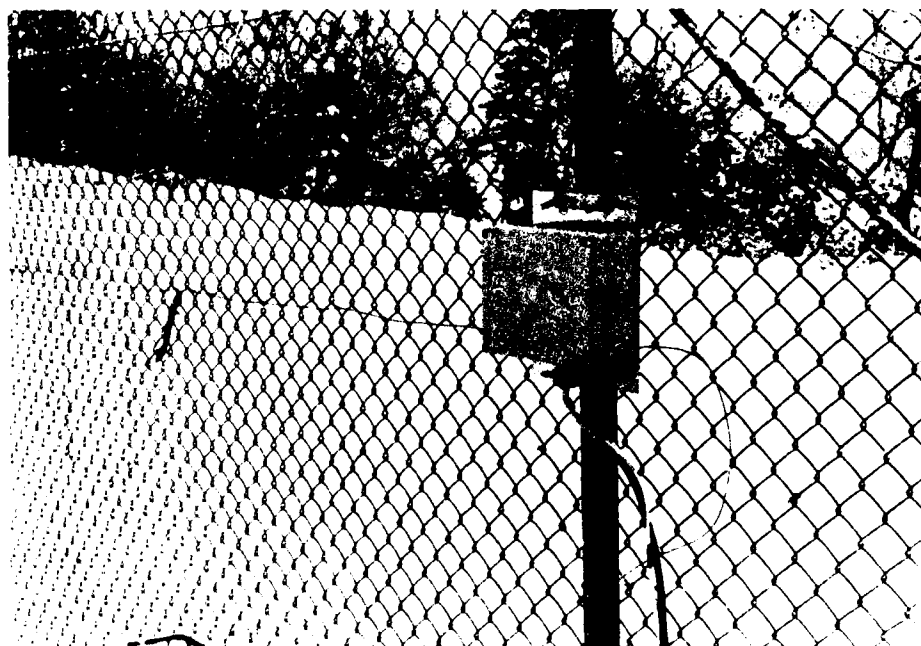

Figure 3. Sylvania FPS-2 processor.

The FPS sensor consists of a 3.175-mm coaxial cable (up to 1,000 feet, or approximately 300 meters, in length) that is attached to perimeter fencing using tie wraps at 45.7-cm intervals. The noisy coaxial cable line sensor is a patented Electret Cable, which, according to manufacturer's specifications, detects a movement in the fence as small as a 39-millionths of an inch. The FPS processor contains signal analyzing and processing circuitry that allows user-controlled amplifier gain levels as well as a count of distinct impulses or vibrations that the processor senses to cause an alarm.

The FPS is termed passive because it does not emit any form of environment-altering emissions such as radio waves; however, the system is not passive in the sense that the cable is a source of current, as are the MILES and BLS cables. The FPS cable, which requires a source of current, alters the current flow similar to the feedback loop of an amplifier. Thus, unlike the MILES and BLS cables that can be employed by amplifying a sensor-generated signal/signature, the FPS sensor cannot be readily employed without the use of a signal processor.

The employment considerations and limitations of the system are natural or man-made environmental conditions that impart motion to the fence that resembles an intruder to the processor, as well as fence conditions that can shorten the life or damage the sensor. Conditions that might contribute to an increased nuisance alarm rate or alter the sensitivity of the system include the following:

- a. Loose fence fabric and hardware.
- b. Loosely mounted barb wire, concertina wire, or ribbon cable.
- c. Swing/slide gates producing mechanical vibrations.
- d. Signs or other fence objects mounted loosely on the fence.
- e. The condition of the fence (e.g., old, rusty, rough, excessive galvanizing material).
- f. Objects that may strike the fence when moved by the wind (e.g., cables, pipes, wires, limbs, large bushes, or objects mounted loosely on the fence).

#### 2.1.2 Active Systems.

2.1.2.1 Sentrax. The Senstar Corporation (1982a,b; 1983) Sentrax security system is a buried-line leaky coaxial cable security system that contains three principal components:

- a. Transceiver module (TM).
- b. Cable set (CS).
- c. Control module (CM).

The TM and CS form the basic sensor system with one transceiver that allows for the use of two sets of sensor cable, each up to 150 m in length. The TM and CM are illustrated in Figure 4.

A single transmitter, receiver, and signal processor are time-multiplexed between two sectors. The radio frequency (RF) signal transmitted along one cable causes an external surface wave to propagate along the cable set. An intruder creates a disturbance in the surface wave that produces a reflected wave on the receiver cable. The reflected wave is demodulated and digitized for processing in the TM's microprocessor. Digital processing is used to detect the disturbance created by an intruder while excluding many disturbances created by small animals and environmental changes.

The TM also includes the necessary hardware and firmware to provide a communications data link over the sensor cable system to the CM. This standard RS-232 data link to the CM can operate over either coaxial cable in which apertures are produced in the outer conductor to provide a controlled amount of coupling. The Sentrax uses contradirectionally coupled continuous wave (CW) leaky cable sensor technology. The contradirectionally coupled CW leaky cable sensor transmits RF energy (40.68 MHz) along one cable and the receiver is connected to the same end of the adjacent cable. The use of contradirectionally coupled technology has the primary advantage of the sensor system, being much less sensitive to environmental changes than codirectionally coupled CW leaky cable sensor system (Harman 1982, 1983). Codirectionally coupled systems transmit along one cable, and the receiver is located on the opposite end of the adjacent cable.

The primary limitations and deployment considerations of the Sentrax are associated with the soil medium in which the security system is placed. The Sentrax RF waves that are emitted from transmitter to receiver form a zone of protection that varies in height and width. The zone of protection is not a uniform field for the length of the sensor. Due to many factors, the dimensions of the detection zone (and the coupling between the cables) vary along the length of the zone. The factors that affect the dimensions of the detection zone include any variable that causes a change in soil conductivity, such as an uneven distribution of soil moisture, nonhomogeneous soil, buried

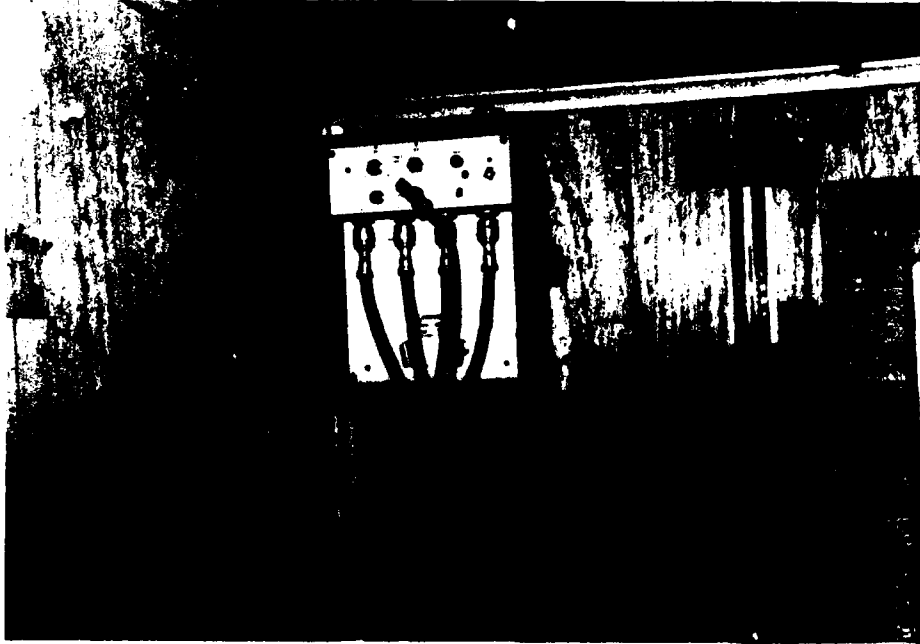

a. Transceiver module.



b. Control module.

Figure 4. Sentrax System modules.

objects, and cable placement (Ballard and Miller 1985).

The use of leaky coaxial cable security technology offers, for the most part, a buried-line sensor system with high probabilities of detection and a low NAR/FAR because of the system's relative immunity to seismic activity and many other environmental noises, such as from small animals, wind, and rain. The weakness of the leaky coaxial system is, as with any buried-line sensor system, the environment into which the system is placed. Any environmental change that affects the initial wave propagation medium is subsequently reflected as a change in the probability of detection and as a change in the nuisance alarm rate.

With the Sentrax, changes in the initial wave propagation layer (the soil) are user-compensated by adjusting the alarm threshold. The alarm threshold can have a range of more than 30 dB for a site that has a seasonal freeze-thaw cycle. The alarm-threshold adjustment is accomplished manually by adjusting a potentiometer on the TM.

2.1.2.2 Stellar System E-field. The basic components of the E-field are:

- a. Field and sense wires with tensioning and insulator hardware.
- b. Terminators.
- c. Sense filters.
- d. Control unit.
- e. Fence poles, poles, roof, or wall to mount the sense and field wires.
- f. Motion Meter/Sonalert.

The Stellar System E-field is an electrostatic field motion detection system (Stellar Systems 1980; undated). The system consists of a pair of long field wires with sense wires running parallel to the field wire. The sense wires are connected to the control unit where the E-field sense signals are monitored and analyzed. The control unit of the E-field is designed to detect a compound signal consisting of an E-field change of amplitude corresponding to the mass of an intruder, the time an intruder is in the field, the rate of field change corresponding to the movement of an intruder, and a preset intrusion time.

The E-field can be employed in several mountings and several different sense wire and field wire configurations, each having advantages and disadvantages. The E-field requires a greater hardware count than any other system tested. The E-field fences employed during this study were in a

free-standing four-wire balanced phase configuration, which offers maximum sensitivity and is operationally identical to the five-wire configuration in use at many locations. (The fifth wire is inactive and serves as a physical barrier.) As installed, each 100-meter section of E-field has a single terminator and two sense filters. The field and sense wires are electrically isolated from the mounting post using standoffs and insulators. The field and sense wires are tensioned to 50 pounds (222 N) using the spring and winder assemblies. Although a single dual-zone controller could have been used during the study, two single-zone controllers (see Figure 5) were used to facilitate comparative testing and to simplify maintenance (Stellar Systems 1980; Stella Systems, undated) and diagnostic testing.



Figure 5. Single-zone E-field system controller.

The Motion Meter/Sonalert, required for setup and trouble-shooting of the system, is an invaluable tool for system operators. After a period of use, a security system operator can monitor the motion meter needle and judge the difference between an E-field violation and a nuisance alarm with a high degree of accuracy.

Some security system designs are difficult to characterize for sources of nuisance/false alarms or the environmental factors that contribute to the NAR/FAR. The E-field and security systems that function similarly are among the systems difficult to diagnose. Environmental factors that were judged as

significant during this study included lightning, wind gusts, grass height, rain, snow, freezing rain, loose security fencing, drifting snow, and a possible change in ground potential due to changing soil conductivity.

One should not make preemptory judgments of the E-field's effectiveness based on the discussion thus far. The system does have a very high probability of detection. However, even when optimally tuned (calibrated), the systems tested demonstrated a high NAR/FAR, and an inordinate investment of effort is required to reduce the NAR/FAR to the level acceptable and necessary for high-priority assets. Fortunately, the system is one that could lend itself readily to advanced computer signal-processing techniques that are generally difficult to achieve using discrete analog hardware and processing techniques.

2.1.2.3 Racon 14000. There are only two components for the RACON system: a transmitter and a receiver. The transmitter and receiver units are mechanically the same and are post-mounted (Figure 6). The posts are offset laterally from the center line of a detection zone to allow beam alignment and longitudinally to allow development of the zone of detection.

The Racon Model 14000-04 is employed as a bistatic microwave intrusion detector (Racon, Inc. 1977). The system operates as a field disturbance sensor that detects movement of personnel or objects through a microwave field



Figure 6. Post-mounted Racon 14000 transmitter.



established between the transmitter and the receiver antenna (parabolic dish). A single zone consists of one transmitter and one receiver. A single line-of-sight, aboveground zone of detection is established between the transmitter and the receiver.

The Racon generates a three-dimensional detection volume (zone). The following description was taken from the SAFE siting criteria (paragraph 17.52.2) (US Air Force 1983).

The received signal is the vector sum of the direct transmitted signal and indirect signals which are reflected from the ground and nearby structures and objects. Moving objects, e.g. humans and vehicles, produce changes in the net vector sum of the received signal. Detection occurs when the resulting received signal crosses a predetermined threshold. The primary detection mode is the beam break where the target passes directly between the Racon transmitter and receiver antennas. A second and equally important mode is the multipath reflection mode in which the reflected wave from an off-axis target destructively interferes with the direct wave at the receiver. The transmitted signal is tone modulated to eliminate mutual interference when multiple RACON sensors are operated in close proximity to one another. Alarms are produced when motion is detected as described above, when the transmitted signal or its modulation is disturbed, when the equipment is jammed or when the enclosure tamper switches are actuated.

The Racon operates at a frequency of 10.525 GHz,  $\pm 25$  MHz, modulated by one of four frequencies: 3, 5, 8, or 13 KHz. The transmitter output power is 0.003 Mw.

The volume of the Racon's detection zone varies according to its installation configuration and the environment of the zone. Among the installation and environmental variables that are significant in determining zonal dimensions are:

- a. Reflection characteristics of the surface under the detection zone.
- b. Reflection characteristics of surfaces adjacent to the detection zone.
- c. Distance between the transmitter and the receiver.
- d. Antenna heights.
- e. Antenna alignment (height, azimuth, elevation angle, and polarization angle).

A partial listing of the environmental constraints that are associated

with the Racon includes electromagnetic interference (EMI) occurring on the sensor's operating frequency, nearby structures, and the surface under the zone of consideration changing in response to changing meteorological conditions--wind, rain, snow, etc.

## 2.2 RECORDING INSTRUMENTATION.

One of the primary goals of this study was to develop efficient methods for recording a data base of environmental factors and the responses of sensors as sensor signatures from multiple-sensor security sites. This report will concentrate on presenting the analog techniques that have been developed, although a powerful data-acquisition computer will soon be added to the data collection and analysis effort, which will expand the multiple-sensor data acquisition and processing capabilities.

### 2.2.1 System Components.

The major components of the analog recording system are described in the following paragraphs.

2.2.1.1 Preamplifiers and Preconditioners. The MILES and the BLS generate seismically/magnetically induced sensor signals of only a few nano-amperes. The signal of the MAID processor and the BLS electronic module must be preamplified to provide isolation, impedance matching, line driving capabilities, and paralleling of the sensor's processor unit. Concurrent with preamplification, the preamplified signal is filtered to reduce the 60-Hz and the 60-Hz primary harmonics noise level.

2.2.1.2 Filters. Both simple resistor-capacitor filters and WES-designed, tunable notch filters were used to reduce the 60-Hz noise level, when required.

2.2.1.3 Amplifiers. Both single integrated-circuit operational amplifiers and ganged general-purpose (100-dB DC) amplifiers were used for signal conditioning, isolation, and buffering, when required.

2.2.1.4 Analog Recorders. A Sangamo Sabre VI 32-channel analog recorder was used to record intrusion and environmental background noises. For intrusion testing and recording of storm data, the record speed was 3-3/4 in/s (approximately 9.5 cm/s). Long-term, unattended data were recorded at 1-7/8 in/s (approximately 4.8 cm/s).

2.2.1.5 Time-Code Generator. A Flow Corporation IRIG-B time code

generator was used to place Julian date, hours, minutes, and seconds on the edge track of the 32-channel analog recording, allowing for selection of exact locationing along a tape for playback and data analysis.

2.2.1.6 Digital Event Controller. A digital event controller was evaluated for collecting uncontrolled test data. A microcomputer controller was used to scan and compare signal levels for preprogrammed alarm conditions and then to actuate recording with the 32-channel recorder. (The controller proved to be inadequate for sensor signature collection, and use was discontinued after development of a digital data acquisition system was initiated.)

## 2.2.2 Sensor/Data-Acquisition Systems Interface.

Figure 7 gives a block diagram of the recording system and the sensor systems. The interface of each sensor to the analog system (and later to the data acquisition computer) required slightly different hardware and interfacing techniques.

2.2.2.1 MILES and BLS. The MILES and BLS transducer cables generate extremely low voltages of a few nanovolts. Because of their relatively low output voltages, several stages of amplification and filtering were necessary to obtain recordable/digitizable voltage levels. The preamplifier interface from sensor cable to recorder consisted of a WES-designed differential input/output selectable-gain preamplifier (set to 500) with an onboard 60-Hz notch filter. The frequency response of the preamplifier was 0.2 to 200 Hz. The preamplifier served as a line driver for the cabling to the instrumentation building where the boosted signal was routed through a WES-designed differential-input 100-dB DC post amplifier, to ganged 60-, 120-, and 180-Hz filters, and then to the Sabre VI analog tape recorder.

The MILES and BLS cables are functionally similar and as such share a common problem of an extremely high susceptibility to 60-Hz noise. Even with four stages of filtering and the utmost attention and care paid to various optimized grounding schemes during the recording and single-stage digital filtering during data reduction, 60 Hz and its primary harmonics are still evident on most of the data collected during this study period.

Note that the simplest transducers, the MILES and BLS cables, require the greatest amount of interfacing hardware.

Both the MAID processor and the Honeywell electronic module have relay closures as alarm signals. These relay closure signals were wired through

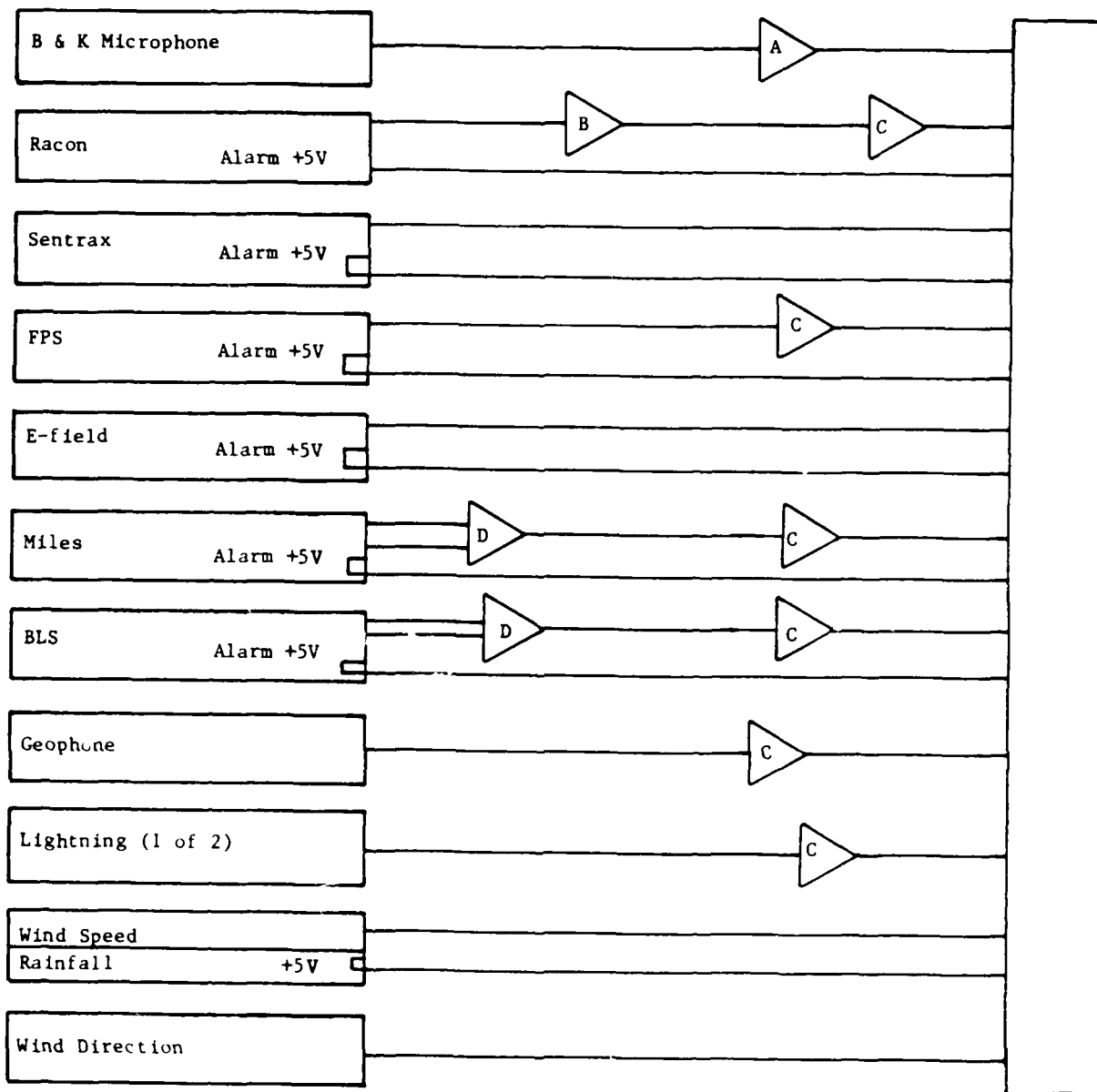

LEGEND

- A - AC Amplifier
- B - Active Rectifier
- C - DC Amplifier
- D - Differential Amplifier

Figure 7. Block diagram of signal flow.

patch panels directly to the recorder. Initially, a 1.5-volt alarm signal was recorded using a 1.5-volt D-cell battery as the voltage source. However, alarm signal voltages were later changed to 0.0- to +5.0-volt levels to allow transistor-to-transistor compatibility of alarm signals.

2.2.2.2 Sylvania FPS. Recording the FPS system responses required far less signal conditioning than for the MILES or BLS. A semiprocessed audio output signal from the signal processor, which varies in frequency and amplitude during fence vibrations, is routed through the WES-designed 100-dB DC amplifiers and then recorded.

The FPS's alarm signal is also a relay closure and is treated in the same way as the MAID and BLS electronic module's alarm relay (see paragraph 2.2.2.1). An alarm signal is produced when a user-selectable number of threshold crossings is detected.

2.2.2.3 Senstar Sentrax. The Senstar Sentrax has provisions to monitor the degree of signal coupling between the sensor cable either at the CM or the TM. For this study, analog data ( $\pm 2.5$  volts DC) representing the magnitude of the coupling of the sensor cables normalized to the threshold setting were taken from BNC outputs (A and B) located on the front panel of the TM. These signals were recorded directly by the tape recorder without amplification.

The Sentrax alarm switch closures (one from each zone) were taken from the communications adapter on the CM and wired through a patch panel directly to the tape recorder. Initially, a 1.5-volt DC alarm signal was recorded using a 1.5-volt D-cell battery as the voltage source although, later in the data collection effort, the alarm voltage was converted to 5-volt DC using power taken from the Sentrax. The alarm response was recorded directly onto tape without buffering.

2.2.2.4 E-field. The E-field sense signals undergo extensive preprocessing in the hermetically sealed sensor module unit of the E-field controller and were unavailable for recording. The signal recorded was a controller-processed measure of the capacitance between sense and field wires and was taken from Test Point 1 of the control panel, the field motion meter test/monitoring connection. The signal reflects the degree of coupling between the field sense wires with a +5 to -5 volt range, in which a positive voltage reflects an intruder entering the field, a near-zero voltage reflects a stable field, and negative voltages are indicative of a mass leaving the field. Because of the high voltages ( $\pm 5$  volts DC), no signal conditioning is

required and the E-field controller output is recorded directly.

The E-field's alarm response is reflected as a relay closure that is interfaced to the recording system in the same way as the MAID alarm signal.

2.2.2.5 Racon. The Racon's microwave carrier is amplitude-modulated with a field-selectable 3-, 5-, 8-, or 13-kHz triangular waveform. The 3-kHz modulator frequency was selected for use during these tests. While the signal can be recorded directly at 15 in/s, a rectifier circuit was developed to simplify visual interpretation of the RACON data, to reduce the sample frequency required during digital data acquisition and to allow analog recording at 3-3/4 in/s (approximately 9.5 cm/s). The rectifier circuit is a simple unity gain capacitively coupled instrumentation amplifier feeding into a signal diode bridge rectifier circuit. The rectifier circuit, installed in the Racon receiver housing, also acts as a line driver to the instrumentation building. The rectified Racon signal is approximately 2-volt peak value and does not require further amplification to be recorded; however, a 100-dB DC amplifier set to unity gain is used to isolate the Racon signal from the data collection system.

The Racon alarm circuit, also a relay switch closure, is interfaced to the recorder without amplification. A 5-volt DC alarm signal is generated using the Racon's 9-volt DC power and a resistive voltage divider.

2.2.2.6 Digital Event Controller. The digital event controller was used in an attempt to obtain uncontrolled target test data by monitoring alarm and data channels. A Z-80-based STD Bus microcomputer and analog-to-digital converters were used. The system was designed to monitor all sensor data and sensor alarm channels as well as wind speed and rate of rainfall. Upon measuring a preset voltage level on one or more channels, singly or combinationally selected, the controller initiated event recording with the Sabre tape recorder. When the tape recorder was activated, integrated wind speed and rate of rainfall data stored by the controller were recorded as analog voltages.

## 2.3 SUPPORTIVE EQUIPMENT AND INSTRUMENTATION.

Acoustic, lightning, and meteorological parameters were measured. These data were necessary for proper evaluation of sensor performance, sensor signature, and response of the sensors to environmental stimuli.

### 2.3.1 Environmental Measurements.

2.3.1.1 Acoustic Data. The acoustic data were taken with a B&K outdoor microphone (Figure 8) with an approximate recorded frequency range of 20 to about 3,000 Hz. There was attenuation of the microphone's signal response above approximately 1,250 Hz due to the 3-3/4-in/s recording speed selected for the tests. The frequency attenuation above about 1,200 Hz should not have an adverse impact on usefulness of the data because the maximum frequencies of interest were from 200 to 500 Hz.

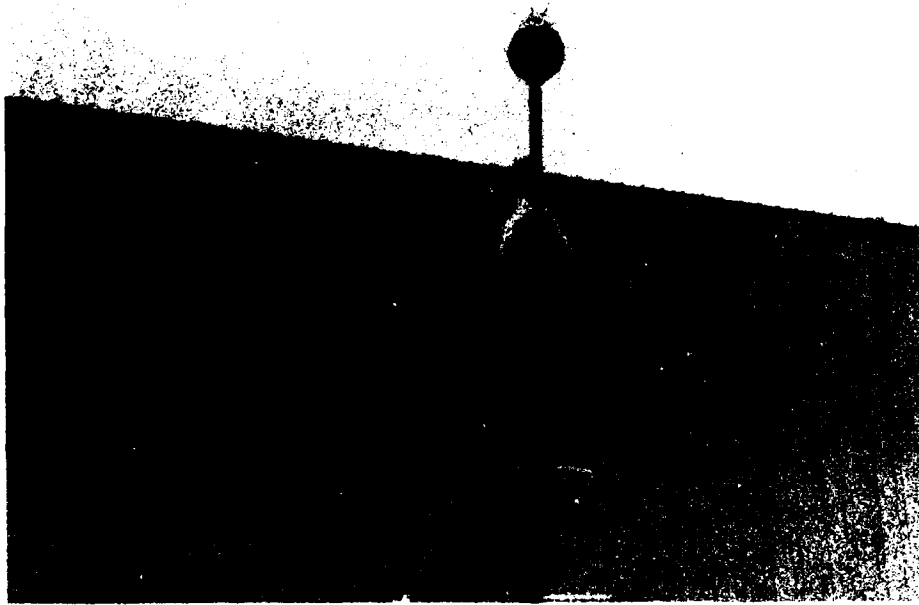

Figure 8. B&K outdoor microphone.

The frequency response of the L4-vertical geophone, 1 to 200 Hz, more than adequately covered intruder-generated responses, on the order of 1 to 200 Hz. The geophone signal was amplified by a WES 100-dB DC amplifier and recorded onto tape.

2.3.1.2 Lightning Detector. The WES-designed lightning detector includes a two-loop (E-W, N-S) antenna system followed by broad-band differential AC amplifiers interfaced to the recording system through 100-dB DC amplifiers. The detector was colocated with the meteorological station amplifier to prevent any possible pickup of EMI associated with the instrumentation building. This gave excellent response not only to observed lightning but to the ionizing feelers that are generated prior to stroke development.

2.3.1.3 Meteorological Parameters. A Campbell Meteorological Station (Figure 9) was used to measure air and soil temperature, relative humidity, wind direction and speed, rainfall, incident solar radiation, and soil moisture. The meteorological station was designed to measure all of these parameters with timed interrogations of the sensors.

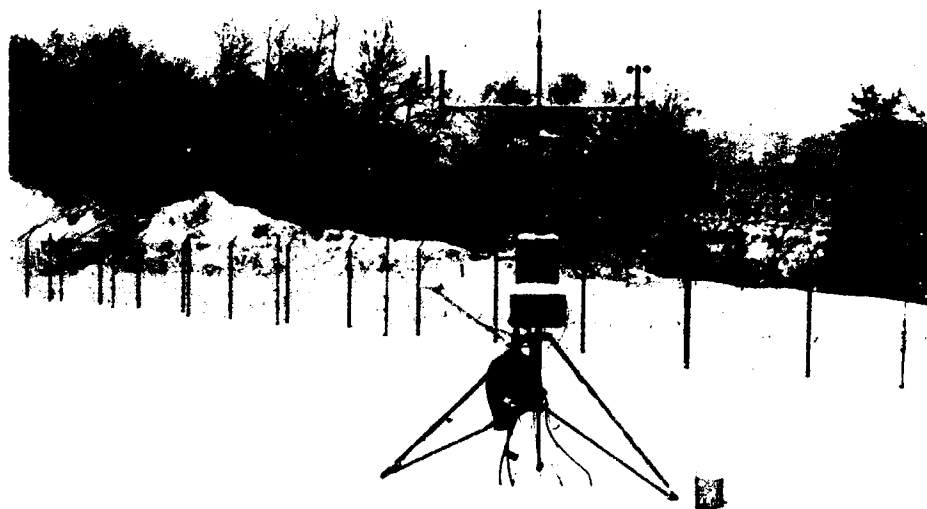

Figure 9. Campbell meteorological station.

Several of the meteorological parameters can be considered as ancillary in the sense that they provide information that is only indirectly applicable to determining the performance of the sensors. Some of the ancillary parameters are relative humidity, incident solar radiation, and air temperature. These measurements are generally applicable only for modeling soil moisture balances or perhaps acoustic/seismic coupling. Other measurements, such as soil moisture and soil temperature, are functions that permit a quantitative analysis of a sensor's response to a given event.

Meteorological parameters that can directly invoke a sensor's response include wind speed, wind direction, rainfall rate, and lightning although, for purposes of this study, lightning should be considered EMI. Generally speaking, wind speeds/directions and rainfall rates that generate nuisance alarms have been observed to be impulse type of events, i.e., events occurring within a few seconds, although the wind might have been high or the rain heavy for an



extended period. In some cases, high winds or heavy rainfall appear to apply a necessary environmental bias to the sensor prior to an impulse generating an alarm. The development of the instrumentation and techniques necessary to record the responses of the sensors to severe weather events has been one of trial and error, due partially to the intermittent nature of such weather and partially to instrument limitations.

Initial efforts were made to use a digital event controller to measure the pulse or triggering effect of wind speed and rainfall. A Z-80-based microprocessor digitally integrated the pulses generated by the anemometer and the rain gage tipping bucket; when preset rates of rainfall and wind speed were exceeded, the controller turned on the Sabre recorder and recorded the sensors' response to the rain or wind. However, this system proved to be unsatisfactory because of the long integration times of the digital event recorder and the time required for the Sabre recorder to stabilize. By the time the recording system was functioning, the event had passed. This "hindsight" view of an event offered by the digital event recorder limited the system's worth.

To circumvent the lack of utility of the digital event controller and to allow recording of wind velocities and rainfall rates during controlled testing and thunderstorms, the anemometer switch closures and rainfall bucket tipplings were recorded directly by the Sabre recorder. Later in the study, the digital anemometer was replaced by an analog anemometer.

The shortcomings of the weather station and the digital event controller will be easily compensated for with the use of a Masscomp data-acquisition computer, which to be added to the instrumentation during 1985-86 because of its high data-acquisition speed and ability to make rapid data conversions and evaluations.

### 2.3.2 Special Equipment.

Four items of special equipment were employed to provide responses from "standard" sources that could be used to determine the uniformity of response by sensor systems in a repeatable manner. Three standard targets (a WES-designed calibrated creeper, a man silhouette, and foil ball) and a small drop hammer were used.

2.3.2.1 Calibrated Creeper. The calibrated creeper (Figure 10), a surface force-generating device, was designed to excite the response of

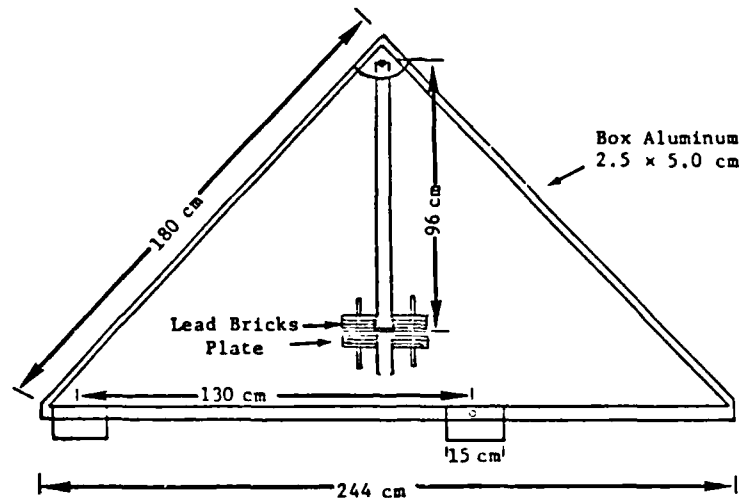

Figure 10. Calibrated creeper.

buried-line sensors to personnel-type sources as a function of the sensors' placement media (Cress 1978). The calibrated creeper consists of triangular aluminum frame from which a 56-kg lead mass is suspended on an aluminum pendulum. The base of the aluminum triangular frame has two 15- by 15-cm pads to allow adjustment of the location and surface force characteristics. In operation, the pendulum is swung and the response of the sensor is recorded. By relocating the pads along the base of the creeper, a peak to peak surface force induced by one pad can be varied from 220 to 800 N (peak to peak). The natural frequency of the creeper pendulum is 0.5 Hz, and the natural frequency and its harmonics are imparted into the soil medium.

The primary purpose of the calibrated creeper during this test program was to allow quantification of the uniformity of sensor responses along the length of the buried-line sensors and to allow correlation of data between a temperate soil site (Vicksburg, MS) and a frozen soil site (Hanover, NH).

2.3.2.2 Man Silhouette. A target made of styrofoam and window screen was fabricated to determine the response of the Sentrax. The target consists of 2 meters of No. 4 aluminum screen (window screen) laced with wire around four hollow construction-grade styrofoam ribs to form a screen cylinder 24 cm in diameter and 152 cm in height. In use, the screen cylinder was suspended from a nylon rope held taut between the security fencing and a support post held upright outside the sensor field. The man silhouette, suspended from a pulley, was then pulled through the Sentrax field at a uniform crossing velocity. The target profile (sensor signature) generated by the man silhouette

was very similar in amplitude and shape to that of a human intruder.

2.3.2.3 Foil Ball. A foil ball was used to generate a uniform response from the Racon and from the E-field sensor. A 25.4-cm-diameter playground utility ball was covered with two layers of aluminum foil, three layers of gray electrical tape, and then laced into a cotton cord net. The ball is towed through the sensor field until it touches the bottom E-field wire.

2.3.2.4 Drop Hammer. A field-expedient drop hammer (Figure 11) was developed to allow testing of the ability of the FPS to detect cutting of the security fencing. The drop hammer consists of a 20-cm length of 1.59-cm-diameter reinforcing bar bent into the shape of an elongated question mark with a small hook on the bottom and six flat 1.59-cm-diameter flat washers taped to it. In use, the drop hammer was suspended from the fence, either from the fence's reinforcing wire or from a wire hanger, and dropped onto a 30.48-cm steel carpenter's rule that was laced into the fence's grid. The hammer was dropped once and caught before the hammer rebounded (Figure 11b). The drop hammer was developed by recording the FPS's response to the fencing being cut (along the bottom and top) and then comparing oscillographic recordings of the FPS's response to various size drop hammers and differing drop hammer masses.



a. Hammer lifted for use.

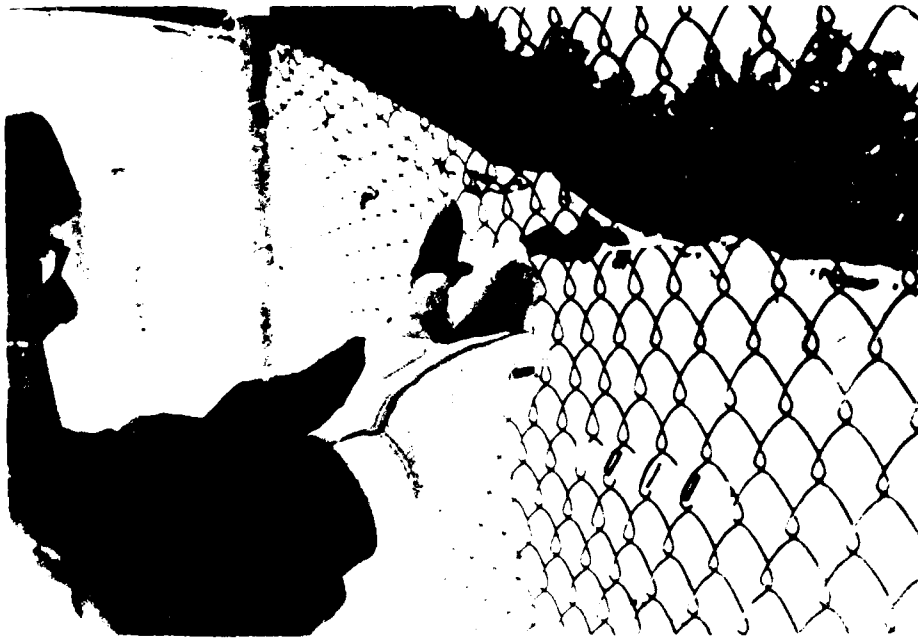

b. Hammer caught before rebound.

Figure 11. Fence drop hammer, used to measure response of FPS.

## SECTION 3

### SITE DESCRIPTION AND TEST PROGRAM

#### 3.1 TEST SITES.

The data base of sensor signatures was collected in both unfrozen and frozen soil test conditions. Unfrozen soil testing was conducted throughout the year at the temperate multiple-sensor test facility located at the WES. Both frozen and unfrozen soil testing was conducted at a site constructed at the Cold Regions Research and Engineering Laboratory (CRREL), Hanover, NH. Descriptions of the WES and CRREL test sites are given in the following paragraphs.

##### 3.1.1 WES Test Facility.

The multiple-sensor test facility (Figure 12) is located on the WES



Figure 12. Aerial photograph of WES multiple-sensor test facility.

reservation on a flat area that is approximately 120 meters wide and 600 meters long, sloping slightly to the northeast. The site is bordered to the south by a gravel road and a drainage ditch. The western border is a continuation of the southern boundary gravel road and a bluff (approximately 7 meters high) adjacent to Durden Creek. The creek and the gravel road form the northern boundary of the site. The eastern boundary is a 20-meter-high hill that is covered with secondary and tertiary vegetation, predominantly hardwoods. The test facility has reasonable drainage. Testing was usually delayed only 1 or 2 days by the heaviest of rains. The site is divided roughly into two test sections: the perimeter security section and the open-field test bed.

The perimeter security test section (Figure 13) consists of a 40- by 150-meter L-shaped high-security perimeter fence (3.04 meters in height) topped with razor wire. The instrumentation building is located within this L-section. The perimeter security sensors were sited 10 meters outside the security fencing.

The open-field test bed includes all of the open flat area beyond the perimeter sensor field. A REMBASS Seismic/Acoustic Classifier Sensor Model DT-562, a three-axis magnetometer head, and a L4 vertical geophone are installed at the 100-meter marker along the 150-meter length of perimeter fencing, 20 meters from the fence. The Campbell meteorological station and the lightning detector are sited 20 meters from the intersection of the L of the fence and in line with the short (40-meter) section of fence. Initially the open-field test area was used to develop vehicular traffic signatures on security sensors (with and without intruders) at various ranges. Currently, the open-field test area has been subdivided into many small test plots to test individual sensors, thus limiting vehicle traffic to lanes parallel to the security test site (12 to 15 meters from the security fence and along the gravel road bordering the test facility at 50 meters from the security fencing).

The test facility contains two 100-meter-long (nominal) security zones. The "B" side is straight and lies along a magnetic azimuth of 315 degrees; the "A" side is L-shaped with a 50-meter length along a 315-degree orientation and a 42-meter length on a magnetic azimuth of 45 degrees. Locations of the sensors with regard to the security fencing are described below.

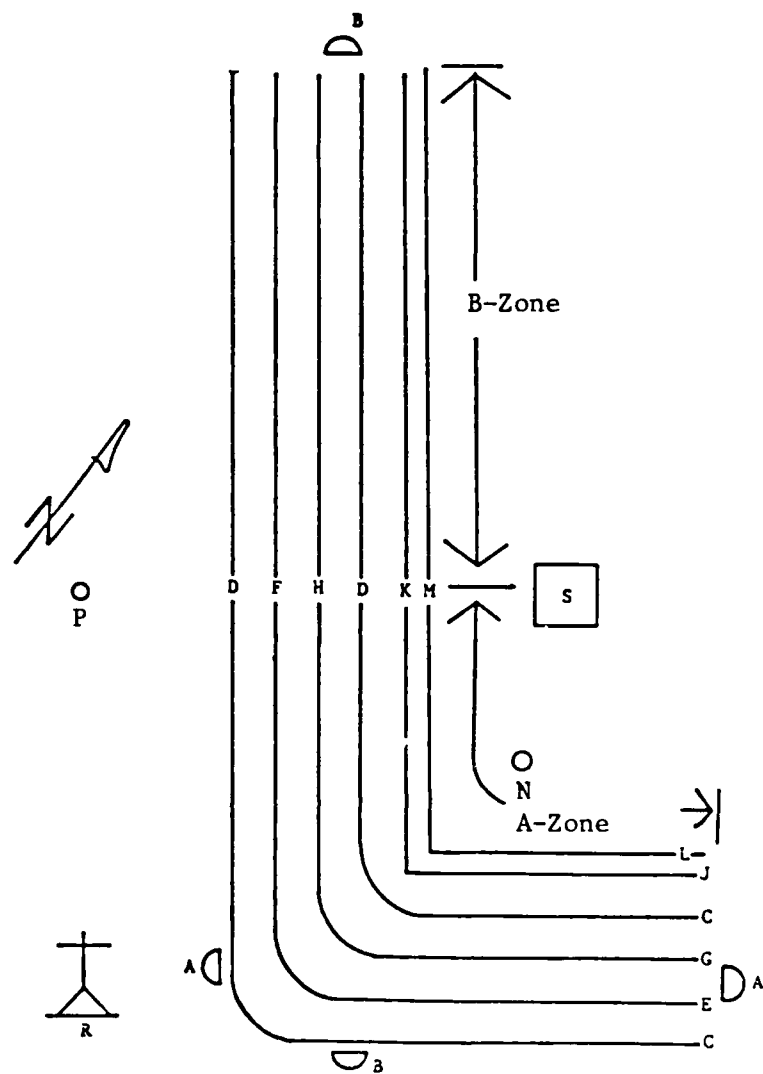

LEGEND

- |                              |  |
|------------------------------|--|
| A - A-zone Racon             | B - B-zone Racon   |
| C - A-zone Sentrax           | D - B-zone Sentrax   |
| E - A-zone BLS               | F - B-zone BLS   |
| G - Z-zone MILES             | H - B-zone MILES   |
| J - A-zone E-field           | K - B-zone E-field   |
| L - A-zone FPS               | M - B-zone FPS   |
| N - Microphone               | P - Geophone, REMBASS, magnetometer<br>with lightning detector |
| R - Meteorological station   |  |
| S - Instrumentation building |  |

Figure 13. Diagram of WES multiple-sensor test facility.

<u>Sensor</u>	<u>Distance from security fence (m)</u>		<u>Depth or configuration</u>
	<u>WES</u>	<u>CRREL</u>	
FPS	0.0	0.0	Sensor cable mounted 1.5 m above ground, on security fencing
E-field	1.0	1.0	4-wire, free standing
Sentrax	5.0	5.0	Buried at a depth of 22 cm, receiver cable at 5.0 m from fence, and transmit cable at 8.0 m from fence
MILES	6.0	6.5	22.5 cm
BLS	7.0	--	45 cm

### 3.1.2 CRREL Test Site

The frozen soil test site was located within the boundaries of CRREL. The site was positioned along a 100-meter section of the western boundary of the reservation. The permanent boundary fence, used to emulate priority fencing, was somewhat loose, unsecured along the bottom, and had several torn and stretched sections. Some places along the fence were washed out to a depth of 0.6 meter or more. The site was in an area that had been a large gully but had been backfilled with a heterogeneous mixture of construction wastes, construction spoils, and silty loam from a nearby borrow pit. The filled area had been graded to an incline that varied in slope from approximately 15 to 20 degrees with the fencing along the base of the slope. The site was approximately 30 to 35 meters wide with approximately 130 meters of usable length.

The eastern boundary of the test site was the Frost Engineering Research Facility, a large metal building of small aircraft hangar dimensions. Construction was still in progress within the building at the time of both winter and summer testing. The southern, western, and northern boundaries of the site were reservation fencing. Immediately beyond the southern fencing was a bare hill approximately 60 meters in height, a portion of which was being used as a borrow pit that closed for the winter. Located 20 meters beyond the western fencing of the reservation was an approximately 80-meter embankment that dipped at approximately 60 degrees to the Connecticut River floodplain. Beyond the northern fence boundary, the terrain is rolling with scrub woody timber.



The layout of the frozen soil test site is shown in Figure 14. Note that the CRREL test site consisted of only one multiple-sensor test zone and that no BLS buried-line sensor was installed.

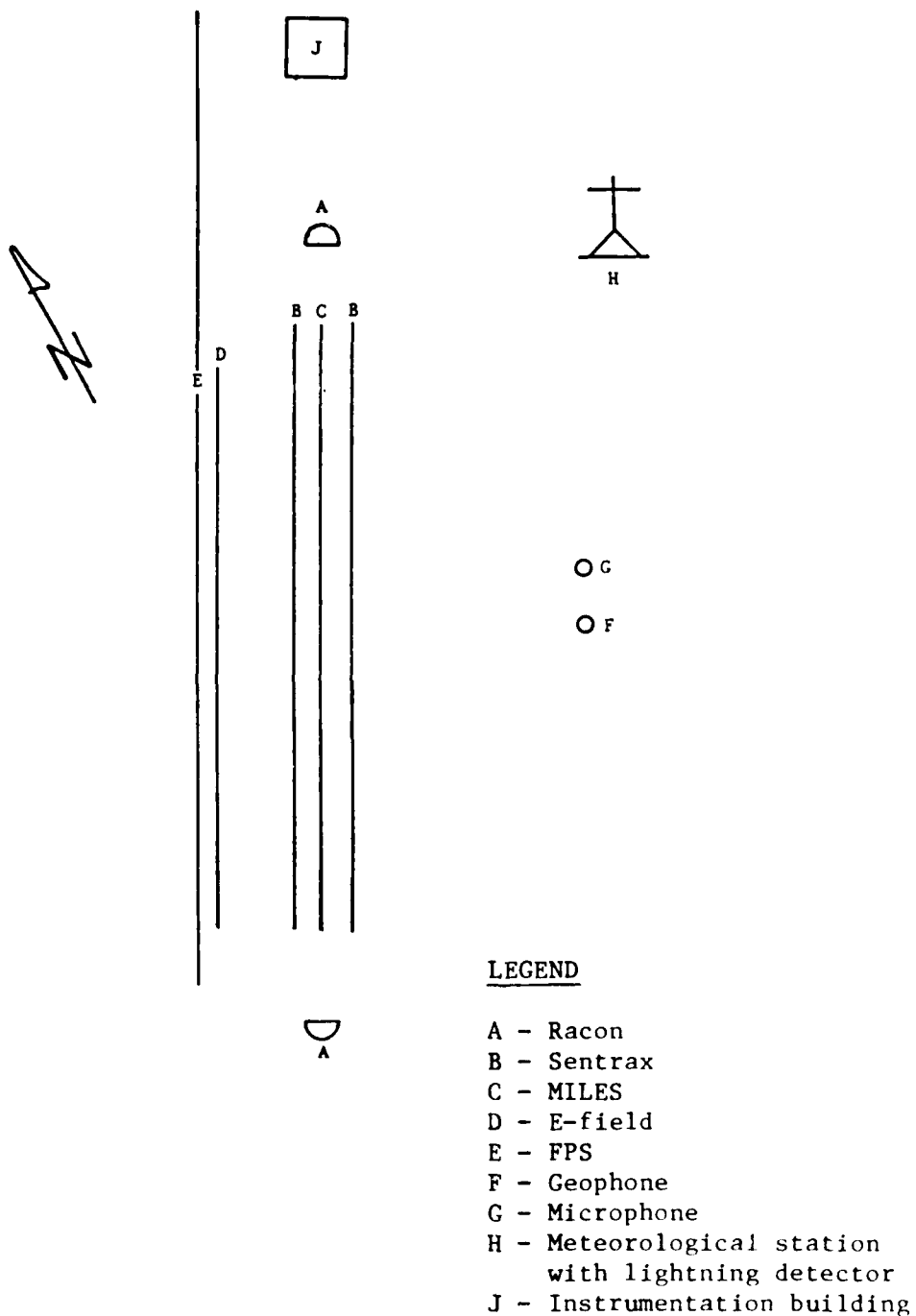

Figure 14. Diagram of CRREL multiple-sensor test site.

### 3.2 SENSOR INSTALLATION.

Where installation specifics such as burial depth were defined in the "Siting Criteria for SAFE Programs," the guidelines were used for sensor installation. If the system was of commercial manufacture and guidance was not prescribed in SAFE-SIT-001, the installation described by the manufacturer that allowed for the highest probability of detection was employed. The sensor installation depths, spatial distributions, and configurations are tabulated in paragraph 3.1.1.

The following paragraphs provide information supplementary to each sensor's installation manual. Where possible, the same technique was used to install each system at both the WES site and the CRREL site.

#### 3.2.1 Sentrax.

The Sentrax cables were buried to a depth of 25.4 cm at both sites. At WES, the cables were placed in trenches excavated using a Ditch-Witch with a 10.16-cm-wide cutting tool. The trenches were backfilled by hand, and the surface material was restored to near initial density using a gasoline-powered construction tamper. Within a few days after placement, detection of the location of the trenches was almost impossible.

Installation at the CRREL site during January 1983 was extremely difficult. The 7- to 10-cm-wide cable trenches were cut into the ground using a ground saw. At the time the cables were placed, air temperatures fell in the  $-35^{\circ}$  to  $-10^{\circ}$  C range and the frost depth extended between 20 and 24 cm. It was felt that the only way the buried sensors could be placed into the frozen soil was to place the cabling in the trench, backfill, and compact the fill immediately behind the ground saw before the friction-heated spoils could freeze. However, extremely low air temperatures and high winds chilled the spoil too rapidly to allow backfilling with unfrozen material. The backfill, heated by the saw blade, rapidly refroze upon exposure to the extreme cold and forced backfilling with a material that ranged in size and texture from a sandy loam of sawdust size, to gravel and cobble size with similar hardness. Although difficult to approximate, it is estimated that only 60 to 70 pct of original compaction was achieved during cable placement.

During succeeding weeks, temperatures rose to above freezing. During the warm periods, frost heaving along the trench occurred and a muddy ridge along the width of the trench developed that extended to a maximum height of about

3 cm. Also, during the periods of warming, snowmelt was observed running into the buried sensor trench, refreezing during the nighttime cooling period or after contact with the frozen strata beneath the surface.

The installation at CRREL was anticipated to have frozen water cavities that developed around the Sentrax cables; however, walk tests along the center line of the zone, between the two cables, indicated a field coupling that, while higher in amplitude than that developed at WES (expected), was not dissimilar in uniformity. Although not as uniform as the WES site, the CRREL site was considered to be representative of conditions in many winter-season environments, and would help to establish limits on installation procedures.

### 3.2.2 MILES Cable.

The MILES cable trenches at WES and CRREL were excavated to a depth of 30 cm. In each case, the trench was backfilled with sand to a depth of 22 cm, the sensor cable was laid, an additional 3 inches of sand was added, and then the trench was backfilled with native material. The descriptions of the relative levels of success achieved in placing the Sentrax cable are equally applicable to the MILES cable.

The MILES cable installed at WES exhibits a high degree of response uniformity to equidistant tests with the calibrated creeper, indicating both soil homogeneity and uniform placement and compaction. Only a very limited response was expected from the frozen soil MILES, and these expectations were verified both with the calibrated creeper and during intrusion tests. Later in the study, in intrusion testing conducted during periods of thaw, an occasional response and alarm was generated, which indicated that perhaps a frozen soil plug had been deflected by an intruder.

### 3.2.3 E-field.

The E-field for both sites was installed using the four-wire end-feed system. The two 100-meter zones at the WES site used two controllers; one operating on the A frequency and the other operating on the B frequency. The use of two separate controllers, instead of one controller in phased operation, was chosen to allow comparative performance analysis between controller systems and also to allow a redundancy of systems. The E-field at the WES site was installed in strict accordance with the manufacturer's recommendations for the free-standing E-field, and the system performed well.

The CRREL installation proved far from optimum, and a great deal of the difficulty may be attributable to the manner in which the E-field posts were placed. The steel posts for the frozen soil site were cast in 30.4-cm sono tubes and then placed into holes that had been drilled using a trailer-mounted auger. Initially the method appeared to be satisfactory; the extreme cold weather at the time of installation did not allow occurrence of freeze-thaw cycles. However, at the onset of daily freeze-thaw cycles and subsequent ground softening due to snowmelt draining into the voids around the tubes, two things happened. First, the 320 pounds (1,423 N) of spring tension on the E-field wires pulled the posts off vertical and caused a loss of E-field tension. (This was corrected with stakes, guy wires, and turnbuckles.) A second more serious problem that could not be corrected was the snowmelt running down the sides of the concrete-filled tubes, freezing, and jacking up the E-field posts in their holes. The bases of some posts were thrust upward more than 12 cm during the testing. Because the posts were ice-jacked upward unevenly, testing indicated that a nonuniform electrostatic field was maintained along the length of the E-field.

#### 3.2.4 FPS.

The FPS installation procedure was the same at both the WES and CRREL sites: the 3.175-mm-diameter coaxial cable was mounted about 1.5 meters above the ground onto the fence with tie wraps at 45-cm intervals. Although tedious, the FPS was the easiest sensor to install. It should be noted that during early testing (prior to May 1985), the WES site had only one FPS processor and, during controlled testing, the FPS sensors were alternately attached and reattached to the processor to reflect the zone being tested.

#### 3.2.5 Racon.

Two Racon systems were installed at the WES: one covered the A zone and the other, the B zone. Both systems operated at the same frequency and used the 3-kHz modulator. There was no cross talk because of the orientation of the zones. The transmitter and receiver units were mounted on 1.5-meter high 10.16-cm-diameter pipes placed in cast-in-place concrete. Receivers were located at the corner of the perimeter fencing with transmitters located at opposing ends of the zone. Both the receiver and the transmitter were offset 6.5 meters from the end of the security zones, with a 45.72-cm

contrapositional axis offset between receiver and transmitter. Only one transmitter and receiver were required for the single-zone CRREL site.

The Racon units were aligned using the method of least AGC voltages, then deliberately misaligned to improve sensitivity. The foil ball target was found to be a most effective method for rapidly determining the degree and direction of misalignment required.

### 3.2.6 BLS.

The BLS cable was installed at a depth of 45.7 cm at the WES site, without the sand protective liner that was placed around the MILES. No BLS was installed at the CRREL site.

## 3.3 TEST PROGRAM.

The testing program was divided into three categories: calibration, controlled, and uncontrolled tests. Calibration tests included sensor probability-of-detection testing and system NAR/FAR tests. The controlled tests were deliberate penetrations (crossings) of the perimeter security system's control zones with and without controlled background noises (vehicular traffic). Uncontrolled tests were records of events that were taken automatically when preset thresholds and/or logic criteria were met by sensor systems using either the digital event controller or continuous recording for extended periods of up to 12 hours using the Sabre tape recorder.

### 3.3.1 Sensor Calibration Tests.

Calibration testing included a sensor probability-of-detection testing phase and a system NAR/FAR testing phase. Intrusion testing was started only after successful completion of all calibration testing.

3.3.1.1 Probability-of-Detection Tests. Sensor calibration was conducted on an individual sensor basis using intrusion techniques to which the sensor was known to be least responsive. The sensitivity and/or detection threshold was adjusted to allow a 90-pct probability of detection. During sensor calibration, the intruder penetrated the detection zone at random locations in a path perpendicular to the detection zone.

Each sensor system was calibrated using the intrusion techniques listed below. The sensitivity/gain/detection threshold was adjusted until each system achieved a 90-pct probability of detection at the 90-pct confidence level.

<u>Sensor</u>	<u>Intrusion technique</u>
Racon	Belly crawl
MAID/MILES	Man creep
BLS	Man creep
Sentrax	Man run
E-field	Man creep
FPS	Fence climb

3.3.1.2 NAR/FAR Testing. Immediately following system calibration, NAR/FAR testing was begun at the test site or facility. A successful NAR/FAR was considered to be a 24-hour period in which no more than two unexplained alarms occurred on any single system. If more than two unexplained alarms occurred on any system within a 24-hour period, the system's sensitivities were reduced and another probability-of-detection test was conducted for that system.

### 3.3.2 Controlled Tests.

Over 1,700 controlled tests were recorded during the data base acquisition tests. Approximately 1,000 tests were conducted at the CRREL site (500 each for frozen and unfrozen conditions), and approximately 700 tests were run at the WES test facility. The following types of tests were conducted:

- a. Single-intruder tests.
- b. Multiple-intruder tests.
- c. Calibrated-source tests.
- d. Controlled-background and nuisance tests.

Controlled testing required that the data-acquisition system operator start and stop the Sabre analog recorder, optimize amplifier gains for different tests, add a voice-track description of the tests, and prepare an abbreviated tape log description of the tests. For safety reasons, a successful penetration of the FPS was defined as the point at which the intruder's full weight was borne by the fence and his/her feet were at least 15 cm off the ground. Each type of controlled test is described in the following paragraphs.

3.3.2.1 Single- and Multiple-Intruder Tests. Single-intruder tests were violations of the zone of detection by a lone individual. Normally, all systems were tested. When more than one person violated a zone of detection (a

multiple intrusion), the intrusion technique could be different for each intruder as well as the entry and exit times. One or more of the intruders might not completely penetrate the zone of detection before exiting.

Intrusion tests included five types of locomotion by two weight classes of intruders: heavy and light individuals weighing approximately 180 pounds (82 kg) or less than 120 pounds (54 kg), respectively. The following is an abbreviated description of each of the five types of locomotion.

a. Walking - a normal walk simulating a pedestrian who was not intentionally penetrating for nefarious purposes and was not attempting to foil the FPS or the E-field.

b. Running - a sprint attempting to violate the zone as expeditiously as possible without any attempt to defeat the FPS or the E-field.

c. Creeping - a slow, deliberate penetration in which the intruder attempted to foil the sensors by light, slow movements and made every attempt to distribute footfalls evenly on the ground. Slow deliberate movements were made through the E-field, easing onto and off the protective fencing.

d. Belly crawling - an attempt to allow maximum spatial distribution of weight along the ground and present a minimum silhouette to the Racon; slow deliberate movements were made through the E-field, and easing onto and off the protective fencing.

e. Duck walking - a walk made in a squatting position in which a maximum effort is made to maintain heel-to-buttock contact and thus a minimum height profile. Slow deliberate movements are made through the E-field, easing onto and off the protective fencing.

3.3.2.2 Calibrated-Source Tests. Several calibrated-source tests were used to allow repetitive measurements between the WES and the CRREL sites and to determine relative changes of sensor response/signature in response to changing environmental conditions. These tests were conducted using three targets (i.e., calibrated creeper, man silhouette, and foil ball) and the drop hammer, all of which were described earlier.

3.3.2.3 Controlled-Background and Nuisance Tests. The controlled-background testing was designed primarily to provide seismic noise sources that characterized noises typically occurring near high-security areas (i.e., light, heavy, and tracked vehicular traffic). A light pickup, a jeep, dump truck (single and dual rear axle), and an M113 armored personnel carrier were driven parallel to the detection zones at ranges of 10, 15, and 25 meters.

Three different-sized dogs that represented different animal types were used to simulate nuisance zone penetrations by wild and domestic animals. The dogs included Great Danes, a German shepherd, a golden Labrador retriever, and miniature dachshund. Where possible, testing included unaccompanied approaches through all sensor fields and movement of the fence by the animals, as well as intrusion of dog and handler within the detection zone.

### 3.3.3 Uncontrolled Tests.

Uncontrolled testing included data taken using the digital event controller and data taken manually during adverse environmental conditions (primarily thunderstorms). The digital event controller monitored all alarm and sensor data channels as well as the microphone, geophone, wind speed, and rainfall for voltage thresholds and logic conditions between channels. The storm data were all collected at the WES facility by recording the responses of all environmental and security sensors over periods of several hours, although no single event generally lasted more than 30 minutes.



## SECTION 4

### PRESENTATION OF DATA

#### 4.1 DATA BASE AND DATA BASE HANDLING.

The multiple-sensor data base maintained at the WES includes analog tape records of over 1,700 controlled tests collected during 1983-85 and over 200 controlled tests collected in 1982. There are also approximately 200 uncontrolled test records. These records together contain more than 100,000 channel-minutes of multiple-sensor data.

Past methods of analyzing tape-recorded analog data (i.e., having tests or selected channels of tests digitized and written to nine-track digital tapes for computer analysis) would be unsatisfactory for such a large data base. An alternate method for accessing and analyzing tests or selected portions of tests had to be developed to reduce the fiscal, logistic, and manpower requirements of data base management.

Because any of the computer options being explored for digital sensor signature acquisition would have some capability for processing analog tape data, it was decided to delay initiation of the data demonstration/analysis phase of this study until a capabilities assessment had been made on the data acquisition computer.

A Masscomp computer, intended primarily as a means of capturing uncontrolled event signatures, has the speed, memory, and hardware necessary to streamline analysis of analog tape data and could provide both an economical and timely end product.

With relatively minor modifications to the software currently being developed for sensor signature acquisition, the Masscomp will be capable of digitizing the existing multiple-sensor 32-channel analog tape library.

#### 4.2 DATA PRESENTATION.

The tabulation below summarizes the tests completed at the WES and CRREL sites. Tables 1 and 2 (presented at the conclusion of this section) provide the tests completed at the WES and CRREL sites, respectively.

Because the software being developed for data acquisition and analog tape reduction is not yet complete, data analysis for this report was limited to displaying a representative sampling of typical sensor responses and associated annunciator alarms.

<u>Test site</u>		<u>WES</u>	<u>CRREL</u>
<u>Test type</u>			
Walk		147	285
Run		159	180
Creep		157	209
Low crawl		108	142
Background and standards, etc.		259	431

Two separate deliberate intrusions are given in the following figures, a run by a 180-pound (82-kg) intruder and a nuisance intrusion by an 80-pound (36-kg) dog. Both intrusions were perpendicular to the zone center line and conducted 30 meters from the origin of the zone. The intrusions were recorded without a background noise source on an analog tape recorder. The sensor response plots were prepared by digitizing the analog tape records at 2,000 Hz and plotting with a line plotter. The alarms generated during the intrusions were projected onto the x-axis. The figures are presented in the order in which intruders are normally detected by the sensors (i.e., Sentrax, Racon, MILES, BLS, E-field, and FPS); additionally, the geophone (far-field noise) responses recorded in the test are given.

Responses typical of the Sentrax to an intrusion by a man-run (Figure 15a) and a dog (Figure 15b) are given. The additional signal displacement caused by the man intruder is due to mass and height of the human intruder. The resultant alarm generation for each event is plotted on the x-axis. The alarm signal for the Sentrax must be acknowledged (reset) at the CM before another alarm signal will be generated.

Figure 16a illustrates a man-run intrusion signature generated by the Racon, and Figure 16b is a plot of the response of the Racon to intrusion by a dog. Alarms generated are plotted along the x-axis. An intrusion at the 30-meter position of zone 2 places the intruder violaters at 80 m from the Racon transmitter. Had the intrusion (assuming the same target and a constant intrusion velocity) taken place at a different distance from the Racon, the area of the sensor signature would depend upon sensor alignment and distance from the transmitter.

Figures 17a and 17b give the response of the MILES cable to the intrusion of a 180-pound man run and 80-pound dog (fast walk), respectively. The alarm

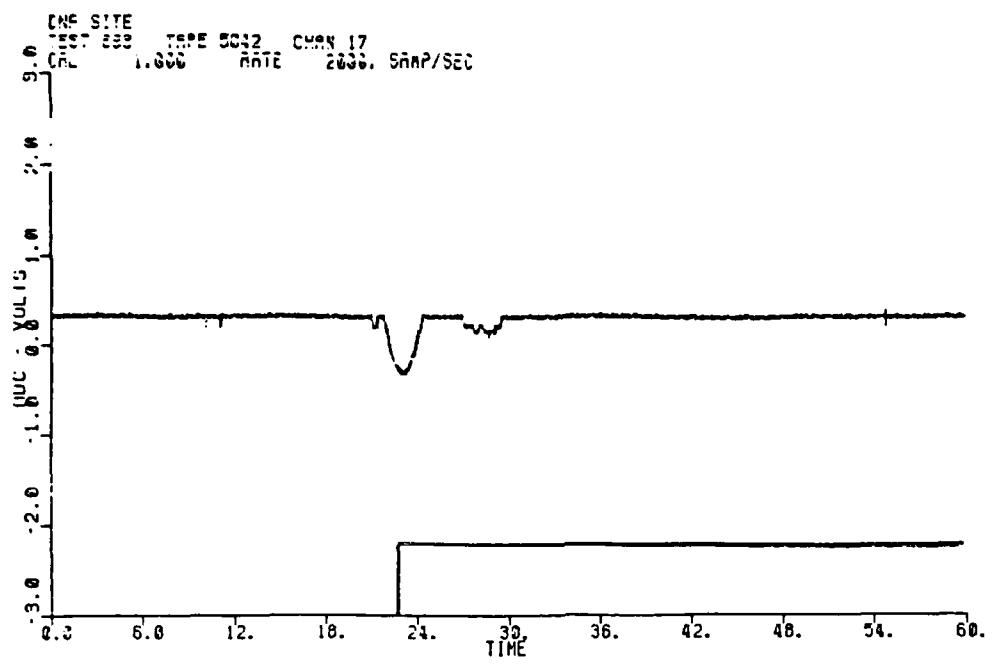

a. Sentrax responses to a man-run.

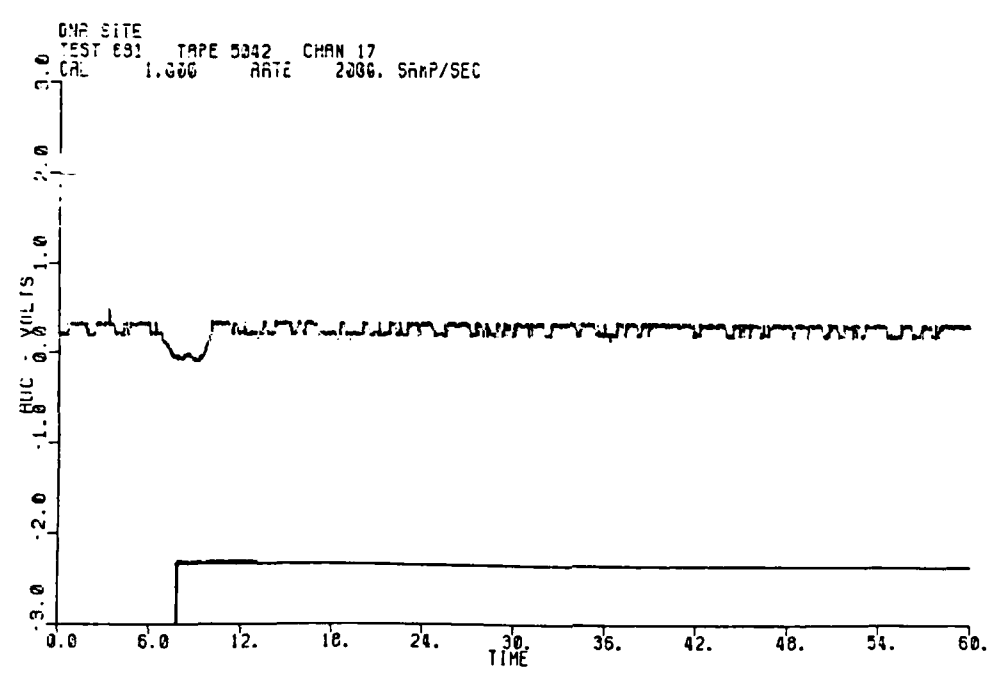

b. Sentrax response to a dog intrusion.

Figure 15. Sentrax sensor signature and alarm response plots.

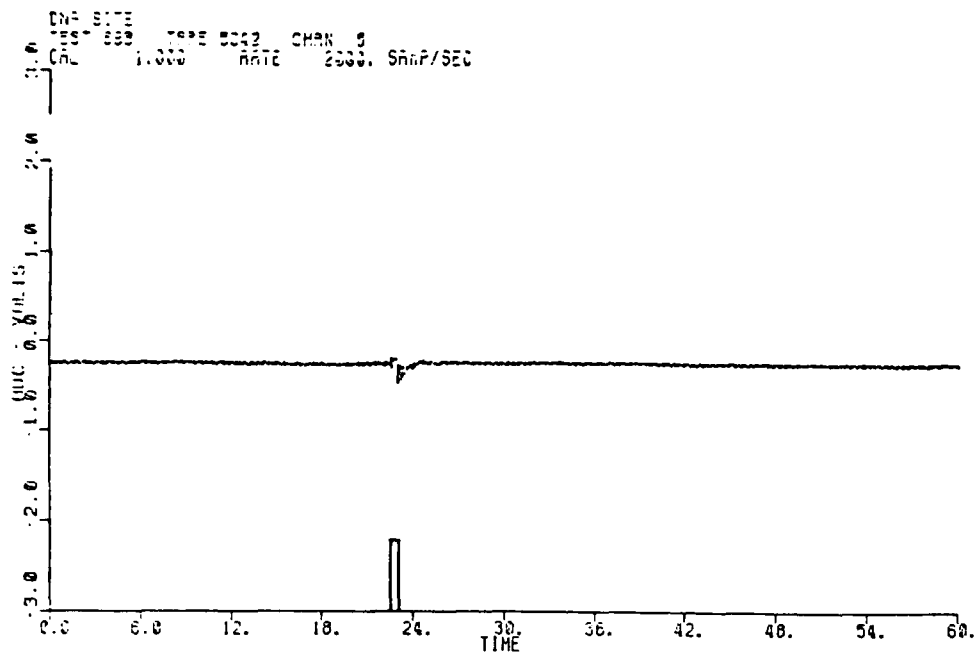

a. Racon responses to a man-run.

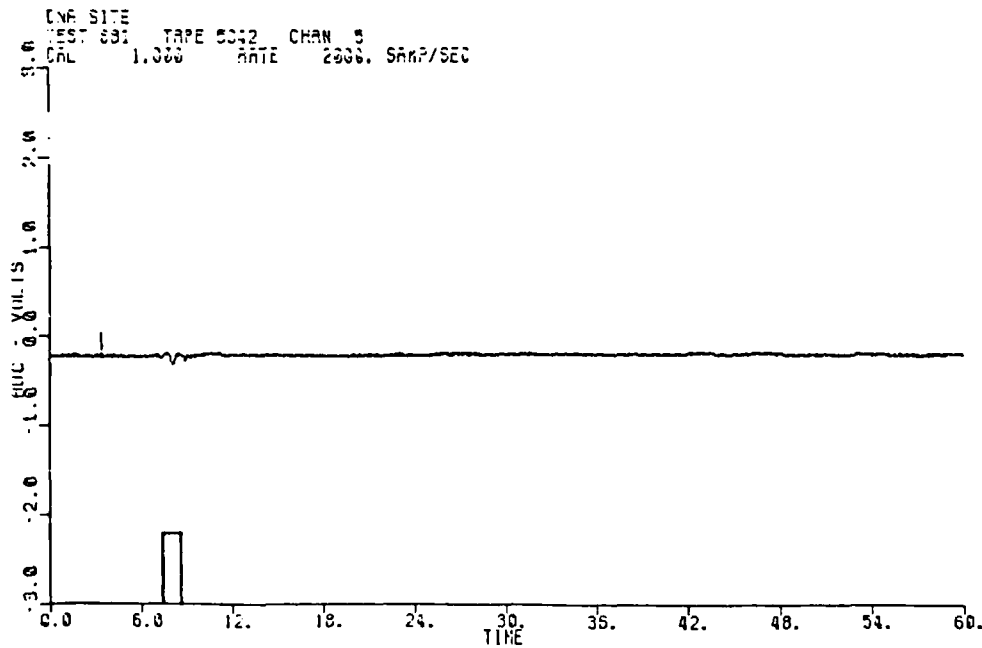

b. Racon response to a dog intrusion.

Figure 16. Racon sensor signature and alarm response plots.

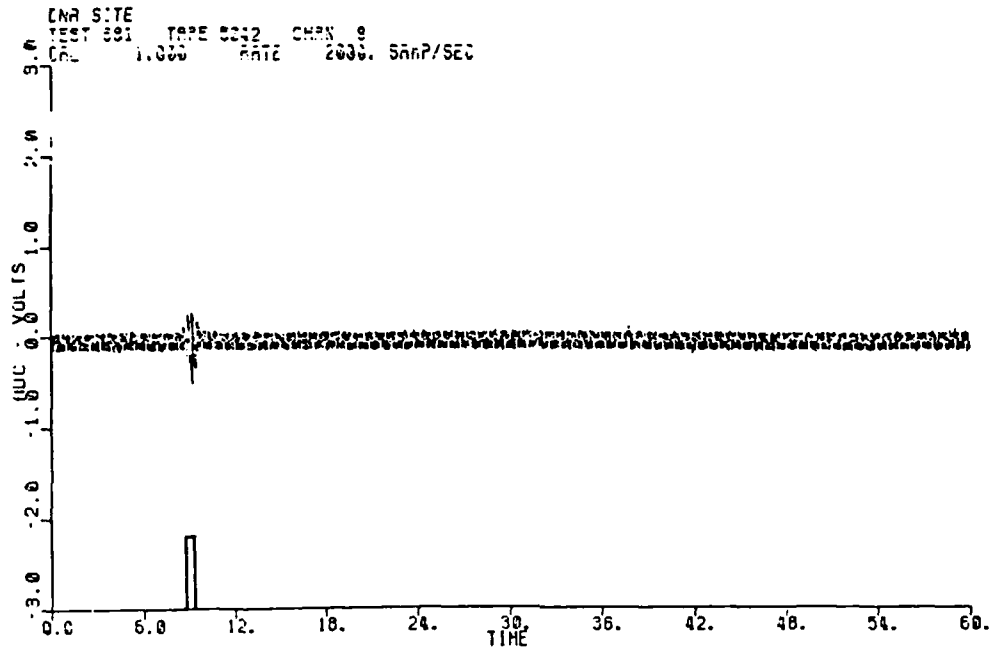

a. MAID/MILES responses to a man-run.

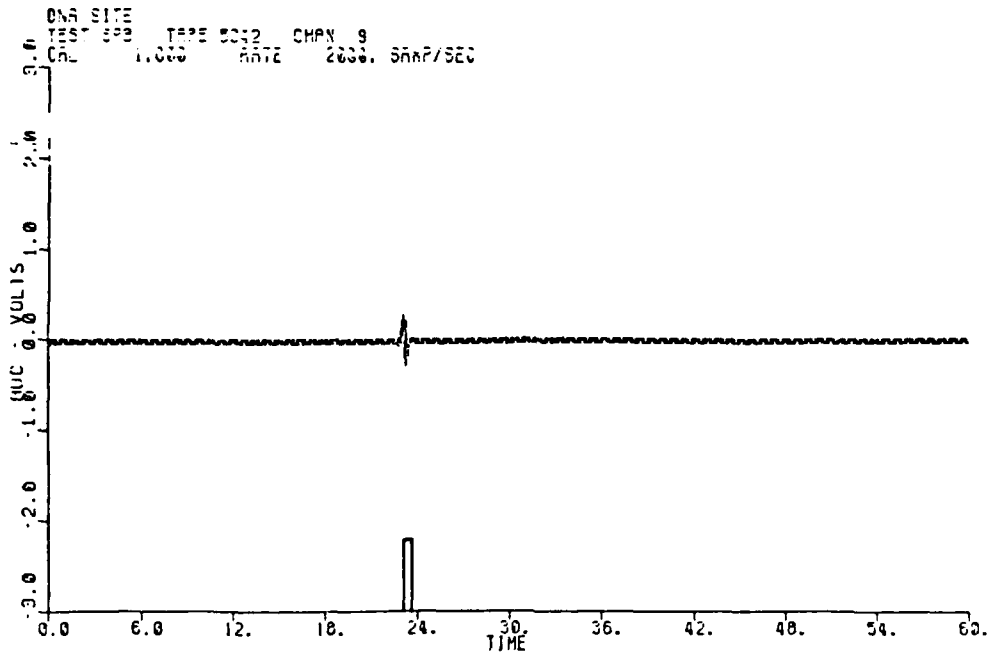

b. MAID/MILES responses to a dog intrusion.

Figure 17. Racon sensor signature and alarm response plots.

response of the MAID processor is plotted along the x-axis for each event. To optimize recorded voltages, 10 dB of gain was used during the animal intrusions. Figure 17b reflects the recorded voltages. Figures 18a and 18b give the response of the BLS cable to a man running and a dog intrusion, respectively. The alarms generated by the electronic module to the intrusions are plotted along the x-axis. The gains applied to the BLS are the same as those applied to the MILES. It is interesting to compare the response of the MILES cable with the MAID processor (Figures 17a and 17b) to the response of the BLS sensor cable with the electronic module (Figures 18a and 18b) for the same tests. Although the responses of the cables and the processors to the intrusions were similar, the background noise responses of the cables were dissimilar, with the BLS demonstrating a much greater 60-Hz component than the MILES cable.

The response of the E-field sensor to the aforementioned intrusions and the resultant alarms is shown in Figures 19a and 19b. The displacements of the digitized analog signal correspond to the movement of the intruder's body limbs through the electrostatic field. The associated alarms are plotted along the x-axis of each figure.

Figures 20a and 20b give the response of the FPS sensor and annunciator to the man running intrusion and the dog intrusion. The dog was made to jump repeatedly against the fence by giving him food through the perimeter fencing. The associated alarms are plotted along the x-axis of each figure.

The response of the geophone to the intrusions is given in Figures 21a and 21b. As with the MILES and BLS sensors, the geophone gain was adjusted to compensate (maximize recorded signal without clipping) for intruder weight.

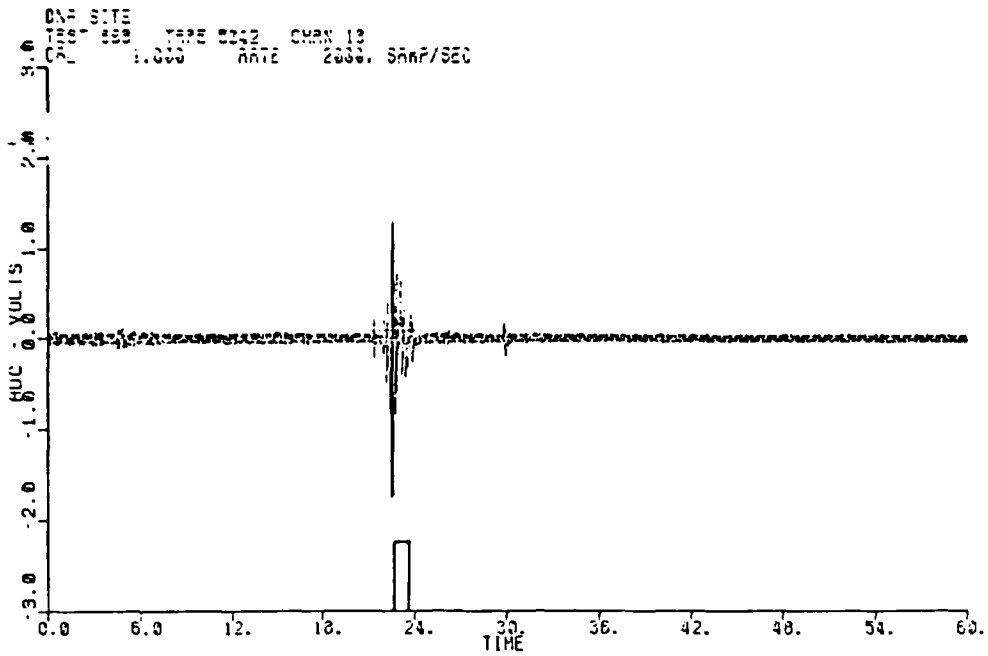

a. BLS sensor and electronic module responses to a man-run.

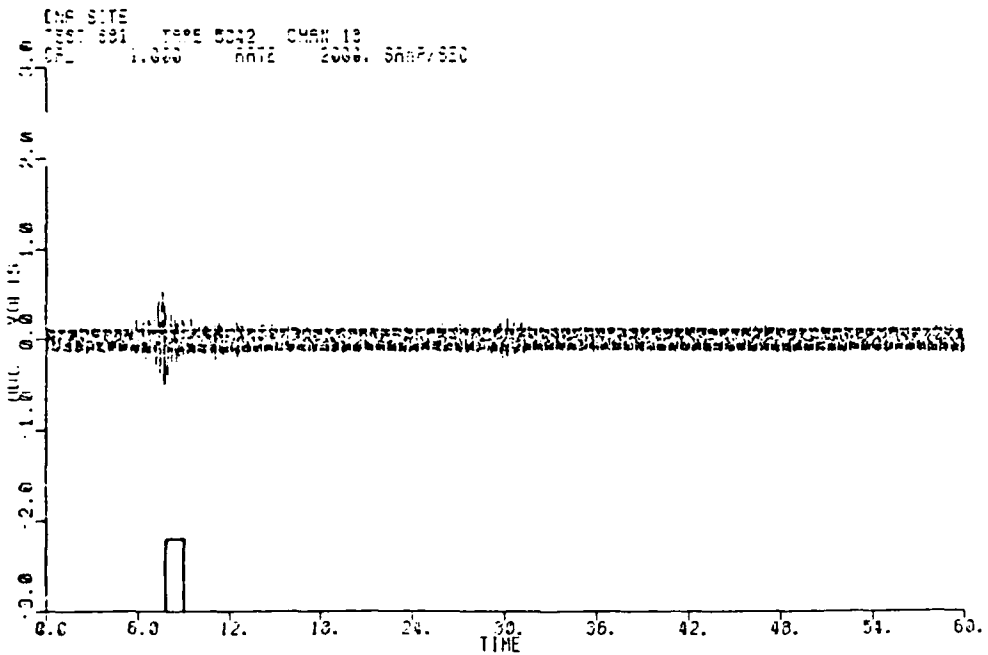

b. BLS sensor and electronic module responses to a dog intrusion.

Figure 18. BLS sensor signature and electronic module alarm response plots.

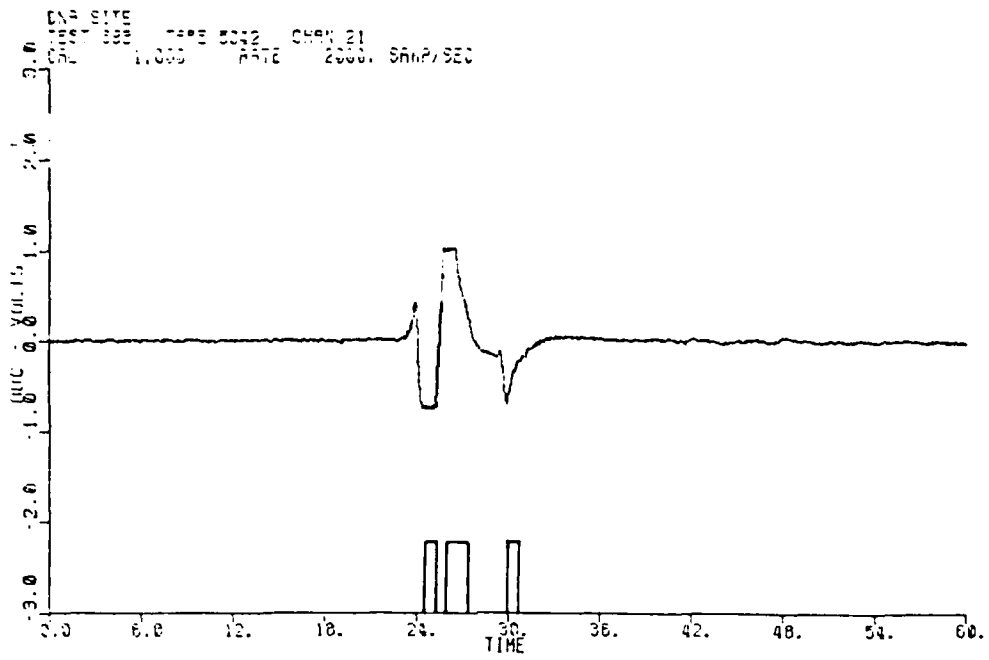

a. E-field responses to a man-run.

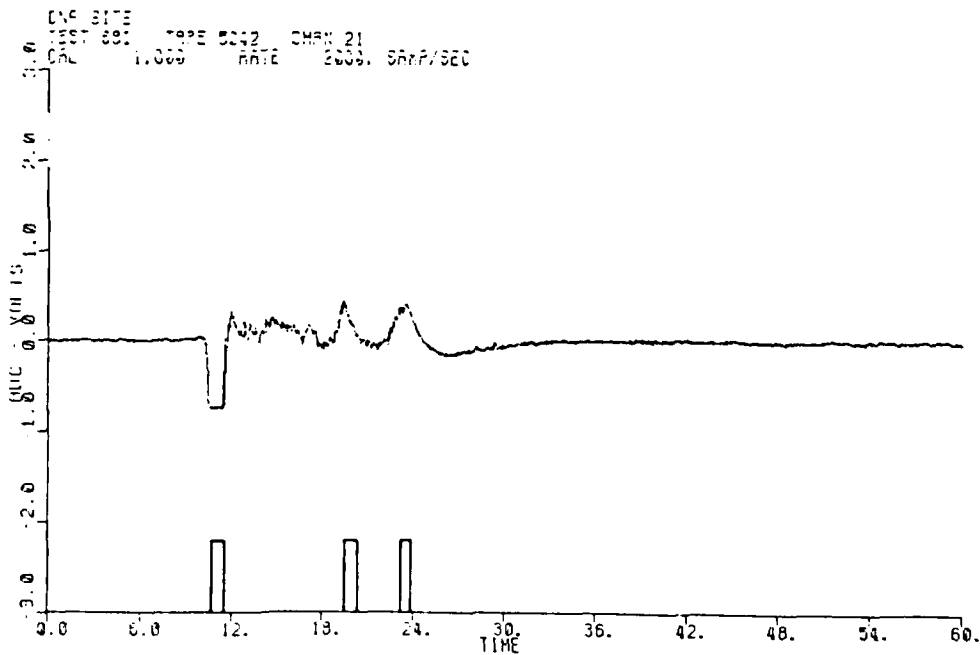

b. E-field response to a dog intrusion.

Figure 19. E-field sensor signature and alarm response plots.



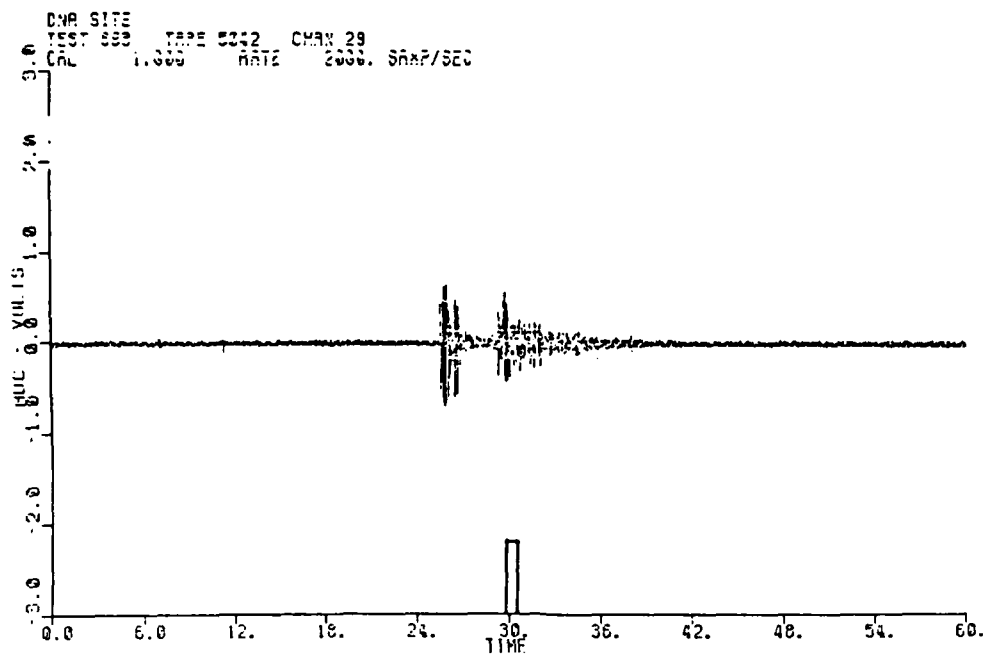

a. FPS responses to a man-run.

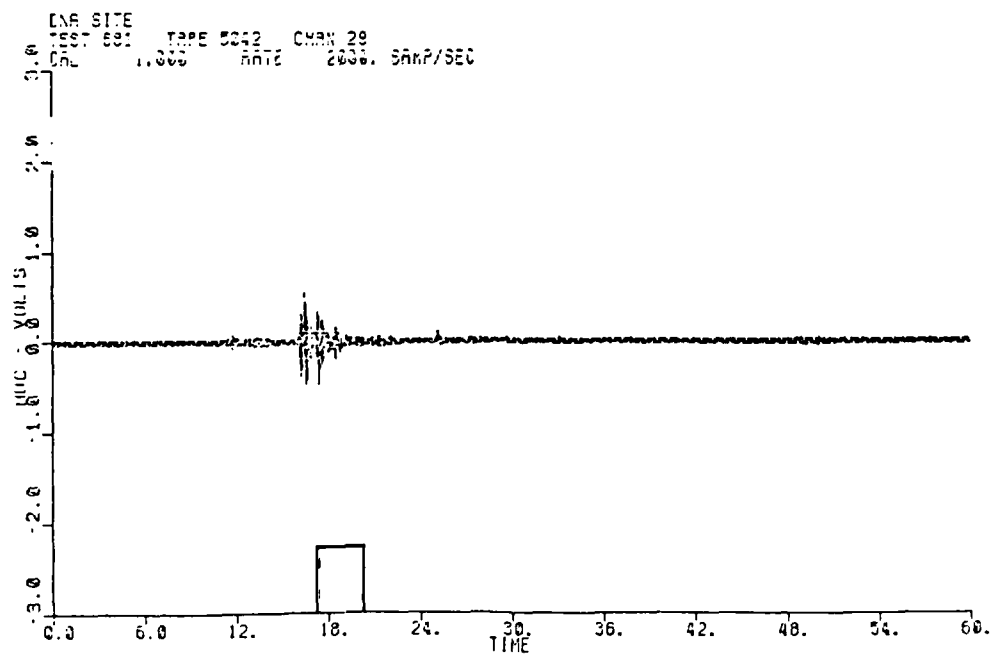

b. FPS response to a dog intrusion.

Figure 20. FPS sensor signature and alarm response plot.

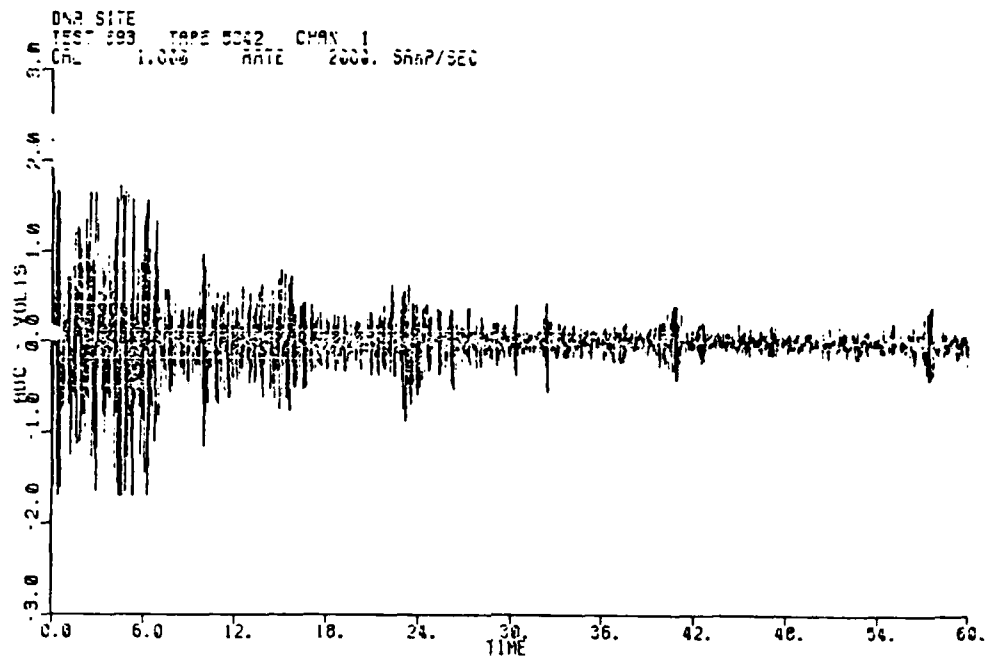

a. Geophone responses to a man-run.

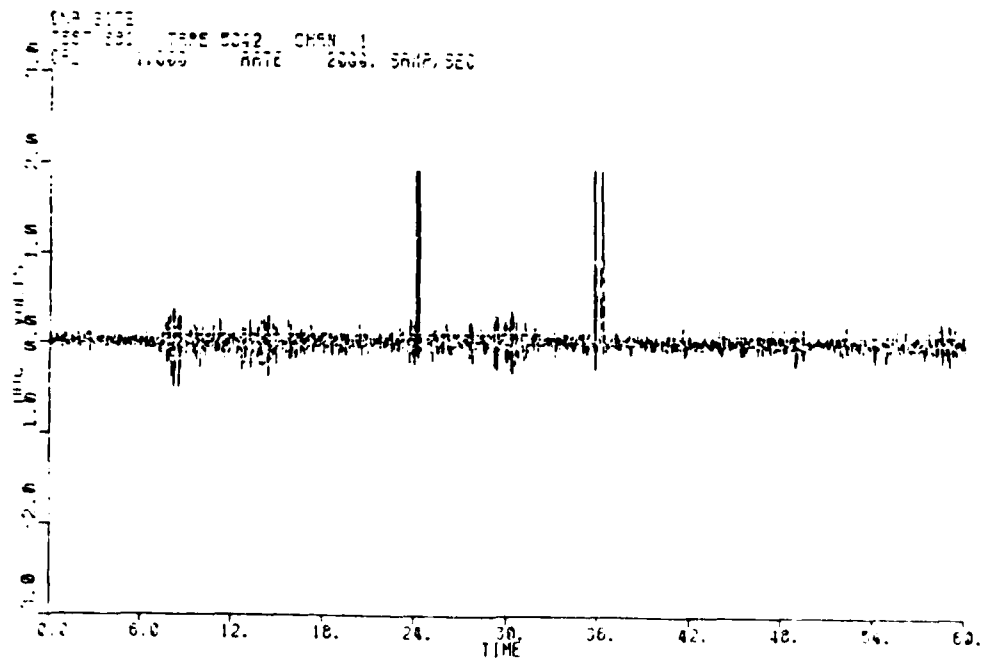

b. Geophone response to a dog intrusion.

Figure 21. Geophone Responses to intrusions.

Table 1. Abbreviated log of WES testing.

<u>Tape No.</u>	<u>Test No.</u>	<u>Julian Date</u>	<u>Type*</u>	<u>Weight†</u>	<u>Background‡</u>	<u>Description/Comments</u>
<u>Summer/Fall 1983</u>						
4159	1-10	83/293	W			Walks
	11-20		DR			
	21-27		C			Creep
4160	28-20		DC			Diagonal creep
	31-40		G			Crawl
	--		W			Trial walk 2, zigzag walk
	CAL #2					141710h, Cal at 20 Hz, 1.750 VRMS all signal ch
	--	83/294	X			Trial walk 3
			X			No Sentrax b data 1-40
	41-50		W	L		80-lb walk
	51-60		R	L		80-lb run
	61-70		C	L		80-lb creep
	71-75		G	L		80-lb low crawl
	CAL #3		X			142715h, 20 Hz, 1.750 VRMS, GAIN =1, B&K, 90 Db, 1 kHz
	--	83/297	X			Trial walk 4
4161	76-85		S			80-lb dog
	CAL #4	83/297	X			Same values CAL #3
	86-92	83/300	B		L	Light vehicle, background
	93-108		C		L	
	109-112	83/301	B		H	Heavy vehicle, background
	113-130		C		H	
	131-134		B		H	Heavy vehicle background
	CAL #5		X			No notch filter in FPS, same values as CAL #4
	135-145	83/319	B		T	Background M113 APC
	CAL #6	83/319				
4162	CAL #7	83/319				
	146-200	83/319	C	H	T	180-lb creep
	201-203		B		T	
	204-225	83/320	S			Fence drop hammer
			S			Calibrated creeper trial
	CAL #8	83/320				

(Continued)

\* W = walk; D (as a prefix) = diagonal (otherwise straight); R = run; C = creep; G = crawl; X = trial walk, test, etc.; S = special; B = background; M (as a prefix) = multiple; D = duck walk.

† L = light weight (100-180 pounds); H = heavy weight (>180 pounds); UL = ultralight weight (<80 pounds).

‡ L = light vehicle; H = heavy vehicle; T = tracked (otherwise, none).

(Sheet 1 of 7)

Table 1. (Continued).

<u>Tape No.</u>	<u>Test No.</u>	<u>Julian Date</u>	<u>Type</u>	<u>Weight</u>	<u>Background</u>	<u>Description/Comments</u>
<u>Summer/Fall 1983 (Continued)</u>						
4163		83/320	S			60-Hz noise test
	CAL #8	83/320				
	226-257	83/322	S			Calibrated creeper
	258-267		G	H		
	268-277		W	H		
	278-290		R	H		
	291-295		S			Speed gun tests
	CAL #9					
4244	CAL #10					
	296-297	83/333	S			UH-1B, helicopter
	CAL #10					
	492-501		R	L	L	
	502		S			Sentrax walk
	503-504		B		L	
<u>Spring/Summer 1985</u>						
4816	505-507	85/98	W			
	CAL #20	85/118				
	508		W	L		
	509-510		R	L		
	511-512		C	L		
	513		W	L	H	15-m dump truck
	514-515		R	L	H	15-m dump truck
	516		C	L	H	15-m dump truck
	517		MW	L		Two intruders
	518-519		MWC	L		
	520		MC	L		
	521		MWR	L	H	
	522		MCR	L	H	
	523		MC	L	H	
	524		MRW	L		
	525		MWC	L		
	526		MC	L		
	527-528		MW	L	L	Two intruders, ranger pickup
	529		MRC	L	L	Two intruders, ranger pickup
	530		MR	L	L	Two intruders, ranger pickup
4817	531		MRW	L	H	Dump truck, 15 m
	532		MRC	L	H	Dump truck, 15 m
	533		MC	LH	H	Dump truck, 15 m
	534		B		H	Dump truck, 15 m
	535	85/124	B			
	536-537		B		H	8-ton bridge truck

(Continued)

(Sheet 2 of 7)

Table 1. (Continued).

<u>Tape No.</u>	<u>Test No.</u>	<u>Julian Date</u>	<u>Type</u>	<u>Weight</u>	<u>Background</u>	<u>Description/Comments</u>
<u>Spring/Summer 1985 (Continued)</u>						
4817	538-539		B		L	Ranger pickup
Cont.	540-542		MW	LH		
	543		MRW	LLH		Three intruders
	544		MRC	LLH		Three intruders
	545		MRW	LLH		Three intruders
	546		B			
	547		MRW	LLH		Three intruders
	548		MWC	LH		Two intruders
	549		MW	LH		Walk parallel to zones
	550		MR	LH		Run parallel to zones
	551		MC	LH		Creep parallel to zones
	552		C	L		
	553		B			
	554-555		MC	L	L	Two intruders, pickup truck
	556		MGC	L	L	
	557		MC	L	L	
	558		MR	L	L	
	559		MRW	L	L	
	560		MW	L	L	
	561		B		L	
<u>WES March 1984</u>						
4354	1	84/91	X			Trial test
	2		X			Trial test
	299-303	84/91	X			Sweep test of MILES/BLS
	CAL #11	84/91				
	304	84/92	B			NAR/FAR test
	305	84/93	S			Storm data
	306	84/93	S			Storm data
	CAL #12	84/93				
4578	307-309	84/93	S			Storm data
	CAL #13	84/93				
4579	310	84/95	S			Storm data
	CAL #14	84/93				
	311	84/120	B			
	312-324		W	H		
	325-326		D	H		
	327		B			Joggers on gravel
	328-337		D	H		
	338-348		R	H		
	349-359		C	H		
	360-368		MW	H		Three intruders

(Continued)

(Sheet 3 of 7)

Table 1. (Continued).

<u>Tape No.</u>	<u>Test No.</u>	<u>Julian Date</u>	<u>Type</u>	<u>Weight</u>	<u>Background</u>	<u>Description/Comments</u>
<u>WES March 1984 (Continued)</u>						
4579	369		B			
Cont.	370-378		MC	H		Three intruders
	379-381		MR	H		
	382-384		MD	H		
	385-389		MDG	H		
	390-391		MDW	H		
	392		MDW	H		Two intruders
	393	84/122	S			Storm data
	394		X			Tape recorder test
	395-399		W	L		
	400-404	84/140	W	L		
	405-414		D	L		
	415-424		C	L		
	425-434		R	L		
	435-437		MR	L		Two intruders
	438		MR	L		Three intruders
	439-441		MR	L		Two intruders
	442		MR	L		Three intruders
	443-445		MR	L		Two intruders
	CAL #16					
	446	84/141	B			
	447	84/148	S			Rain
	CAL					FPS cal
	448-457		G	L		
	CAL #17					
	458-467		G	L	L	Light pickup
	468-471		B		L	
	472-481		W	L	L	
	482-491		C	L	L	
4818	562		MWR	HHL	H	Three intruders, bridge truck
	563		MWRC	HHL	H	
	564		MRW	HHL	H	
	565		MCWG	HHL	H	
	566		MGR	HHL	H	
	567		G	H	H	
	568		MWRG	HHL	H	Three intruders, bridge truck
	569		MGW	HHL	H	Three intruders, bridge truck
	570		MG	LLH	L	Three intruders, pickup truck
	571		MC	LLH	L	Three intruders, pickup truck

(Continued)

(Sheet 4 of 7)

Table 1. (Continued).

<u>Tape No.</u>	<u>Test No.</u>	<u>Julian Date</u>	<u>Type</u>	<u>Weight</u>	<u>Background</u>	<u>Description/Comments</u>
<u>WES March 1984 (Continued)</u>						
4818 Cont.	572		MCW	LLH	L	Three intruders, pickup truck
	573		MCW	HLL	L	↓
	574		MRW	LLH	L	
	575		MCG	LLH	L	
	576		MWG	LLH	L	
	577		B	--	L	
	578		B	--		
	579-584	85/125	B	--	L	Pickup truck
	585-592		B	--	H	Bridge truck
	593		B			
	594		MRG	H	H	Three intruders, bridge truck
	595		MRW	H	H	Three intruders, bridge truck
	596		MWC	H	H	Three intruders, bridge truck
	597		MG	H	H	Three intruders, bridge truck
	598		MGR	H	H	Four intruders, bridge truck
	599		MRCG	H	H	Three intruders
4968	600		MW	H	H	Two intruders
	601		MWG	H	H	↓
	602		MGC	H	H	
	603		MW	H	H	
	604		MWR	H	H	
	605		MR	H	H	
	606		MC	H	H	
	607		MCG	H	H	
	608		MG	H	H	
	609-610		B	--	H	
	CAL #23					
5078	611-612	85/158	S	--		Lightning and rain
	CAL #24					
5184	CAL #24	86/167				
	CAL #24A					
	613		MW	L		Two intruders
	614		MW	H		↓
	615		MC	L		
	616		MC	H		
	617		MG	L		
	618		MG	H		
	619		MR	L		

(Continued)

(Sheet 5 of 7)

Table 1. (Continued).

<u>Tape No.</u>	<u>Test No.</u>	<u>Julian Date</u>	<u>Type</u>	<u>Weight</u>	<u>Background</u>	<u>Description/Comments</u>
<u>WES March 1984 (Continued)</u>						
5184	620		MR	H		Two intruders
Cont.	621		MW	L		Two intruders
	622	85/167	S	UL		Back handsprings
	623		MC	L		Two intruders
	624		MG	L		Two intruders, high crawl
	625		MR	L		Two intruders
	626		MW	L		
	627		MW	H		
	628		MC	L		
	629		MC	H		
	630		MG	L		
	631		MG	H		
	632		MR	L		
	633-634		MR	H		
	635		MG	L		
	636		MC	H		
	637		MW	H		
	638		MR	H		
	639		B			
5041	640	85/181	B			
	641		MW	H		Two intruders
	642		MC	L		
	643		MC	H		
	644		MG	L		
	645		MG	H		
	646		MR	L		
	647		MR	H		
	648		MW	L		
	649		MW	H		
	650		MC	L		
	651		MC	H		
	652		MG	L		
	653		MG	H		
	654		MR	L		
	655		MR	H		
	656		MC	H		
	657		G	L		
	658		MR	H		Two intruders
	659		MW	H		
	660		MW	HL		
	661		MW	HL		
	662		MC	L		
	663		MC	H		
	664		MG	L		

(Continued)

(Sheet 6 of 7)



Table 1. (Concluded).

<u>Tape No.</u>	<u>Test No.</u>	<u>Julian Date</u>	<u>Type</u>	<u>Weight</u>	<u>Background</u>	<u>Description/Comments</u>
<u>WES March 1984 (Concluded)</u>						
5041	665		MG	H		Two intruders
Cont.	666		MR	L		↓
	667		MR	H		
	668		MW	L		
	669		MW	H		
	670		MC	L		
	671		MC	H		
	672		B			
	CAL #25					
5042	CAL #26	85/184				
	673-683		S			80-lb dog
	684		S	H		80-lb dog and handler
	685		S			Zigzag down field
	686		G	H		Center-line run by dog
	687		W	H		
	688		C	H		
	689		R	H		
	690		MW	H		Two intruders
	691		MC	H		Two intruders
	692		MR	H		Two intruders
	693		R	H		Two intruders
	694		B			
	695	85/190	MR	H		13 runs in 3 min

Table 2. Abbreviated log of CRREL testing.

<u>Tape No.</u>	<u>Test No.</u>	<u>Julian Date</u>	<u>Type*</u>	<u>Weight†</u>	<u>Background‡</u>	<u>Description/Comments</u>
<u>CRREL Data Winter 1984</u>						
4245	CAL #1					
	1-4	84/38	B		L	CJ-5, jeep
	5		B			Vehicle off
	6-10		B		L	
	11-20		C	H	L	Vehicle at 15 m
	21-28		G	H	L	
	29-33		W	H		
	34-38		G	H		
	39-43		R	H		
	44-48		C	H		
	CAL #2	84/39	B			
	50		B		L	Vehicle at 15 m
	51		G	H	L	
	52-55		W	H	L	
	56-59		DG	H	L	
	60-61		B		L	
	62-65		DR	H	L	
	66-69		DG	H	L	
	70-73		DG	H	L	
	74-77		DW	H	L	
	78-81		DC	H	L	
	82-83		DR	H	L	Tape ran off reel
4246	83-85		DR	H	L	Repeat #85
	86-89		DR	H	L	
	90		S		L	Jeep starting
	91-92		B		L	Jeep at 15 m
	CAL #3					
	93	84/40	B			
	94-95		B		L	
	96-99		DG	H	L	
	100		DC	H	L	
	102-104		DC	H	L	
	105-108		DR	H	L	
	109-115		DW	H	L	Jeep at 25 m
	116		B			

(Continued)

\* B = background; C = creep; G = crawl; W = walk; R = run; D (as a prefix) = diagonal (otherwise straight); S = special; M = multiple; U (as a prefix) = unattended; D = duck walk; X = trial walk, test, etc.

† H = heavy weight (180 lb); L = light weight (<180 lb).

‡ L = light vehicle; H = heavy vehicle.

(Sheet 1 of 11)

Table 2. (Continued).

<u>Tape No.</u>	<u>Test No.</u>	<u>Julian Date</u>	<u>Type</u>	<u>Weight</u>	<u>Background</u>	<u>Description/Comments</u>
<u>CRREL Data Winter 1984 (Continued)</u>						
4246	117-119		W	H	L	
Cont.	120-129		G	H	L	
	130-141		R	H	L	
	142-151		C	H	L	
4247	CAL #4	84/40				
	152-159		B		H	5-ton AWD dump truck loaded with sand at 15 m
	160-161		B		H	Truck at 25 m
	162-166		B		H	
	167	84/41	B			
	168-177		W	H	H	Truck at 15 m
	178-181		B			
	182		S	H		Sentrax center-line walk
	183-184		B			Welder in FERF bldg
4248	CAL #5	84/41				
	185	84/42	B			
	187-195		G	H	H	Truck at 15 m
	196-205		G	H	H	Truck at 25 m
	206-212		W	L		Intruder (wt 110 lb)
	213-217		G	L		
	218-222		C	L		
	223-224		S			Sentrax walk
	225-229		R	L		
	230-239		W	L	L	Jeep at 15 m
	240-245		G	L	L	
	246-255		C	L	L	
	256-261		R	L	L	
	262-271		W	L	L	Jeep at 25 m
	272		G	H		
	273-278		G	L	L	Jeep at 25 m
	279-284		C	L	L	
	285-290		R	L	L	
	291		MW	LH		2L, 2H intruders
	292		MC	LH		↓
	293		MR	LH		
	294		MG	LH		
	295		MR	LH		
	CAL #6	84/42				Note cal number duplicate
4349	CAL #6	84/42				
	296-307	84/42	G	L	H	Dump truck at 15 m
	308		B			
	309	84/43	B			

(Continued)

(Sheet 2 of 11)

Table 2. (Continued).

<u>Tape No.</u>	<u>Test No.</u>	<u>Julian Date</u>	<u>Type</u>	<u>Weight</u>	<u>Background</u>	<u>Description/Comments</u>
<u>CRREL Data Winter 1984 (Continued)</u>						
4349	310-316		S			Foil ball
Cont.	317-320		W	L	H	Dump truck at 15 m
	321-333		S	--	--	Great Dane dog
	334-339		W	L	H	Dump truck at 15 m
	340-345		C	L	H	
	346-351		R	L	H	
	352-361		W	L	H	Dump truck at 25 m
	362-367		R	L	H	
	368-373		C	L	L	
	374-375		S	H		MILES cable walk
	376-381		S			Foil ball
	CAL #7					
4350	CAL #7	84/43				
	382	84/44	B			
	383-393		S			German shepherd
	394-395		B			
	396-402	84/45	S			FPS drop hammer
	403-407	84/46	S			Calibrated creeper
	CAL #8	84/46				
4351	CAL #8	84/46				
	408	84/46	S			Fiberglass pole into E-field
	409-414		S			Fiberglass pole w/foil ball
	415		S	H		Sentrax CL walk
	416		B			
	417		S	H		MILES cable walk
	DDD-SSS	84/47	UB			Tape controller
	418-422	84/48	W	H		Walk at 0 m
	423		S			Man silhouette
	424		W	H		0 m
	425		W	H		0 m, not into E-field
	426		S			Man silhouette
	427		W	H		
	428		S			Man silhouette
	429		W	H		
	430		S			Man silhouette
	431		W	H		
	432		S			Man silhouette
	433		W	H		
	434		S			Man silhouette
	435		W	H		
	436		S			Man silhouette
	437		W	H		

(Continued)

(Sheet 3 of 11)

Table 2. (Continued).

<u>Tape No.</u>	<u>Test No.</u>	<u>Julian Date</u>	<u>Type</u>	<u>Weight</u>	<u>Background</u>	<u>Description/Comments</u>
<u>CRREL Data Winter 1984 (Continued)</u>						
4351	CAL #8	84/46				
Cont.	445		B			
	446		S			Foil ball drag
	UUU-ZZZ	84/49	UB			Tape controller
	C1-C8	84/49	UB			Tape controller
	447	84/49	B			
	448-449		D	H		
	450		D	L		
	451		D	H		
	452		B			
	453		D	L		
	454		D	H		
	455		D	L		
	456		D	H		
	457		D	L		
	458		D	H		
	459		D	L		
	460-463		MW	LH		Four intruders
	464-465		MC	LH		Four intruders
	466-467		MW	LH		Four intruders
	CAL #9	84/49				
4352	CAL #9	84/49				
	468		MDW	LH		Four intruders
	469		MC	LH		Four intruders
	470-472		MR	LH		Four intruders
	473		MW	LH		Four intruders, stopping in field
	474		MC	LH		Four intruders, stopping in field
	475		MW	LH		Four intruders, W and D, stopping in field
	476-479		MW	LH		Four intruders, stopping in field
	480		MW	LH		Three intruders
	481-483		DMW	LH		Three intruders
	484		DMW	LH		Four intruders
	485-487		MW	LH		Four intruders
	488-489		MW	LH		Three intruders
	490		MW	LH		Two intruders
	491		MW	LH		Three intruders
	492		MW	LH		Three-Two walking, 1 duck walk
	493		MDW	LH		Four
	494		MDW	LH		Four, 1 left behind E-field

(Continued)

(Sheet 4 of 11)

Table 2. (Continued).

<u>Tape No.</u>	<u>Test No.</u>	<u>Julian Date</u>	<u>Type</u>	<u>Weight</u>	<u>Background</u>	<u>Description/Comments</u>
<u>CRREL Data Winter 1984 (Concluded)</u>						
4352	495		DMW	LH		Four, multiple diagonal walk
Cont	496-498		W	L		Walk out behind E-field
	499-501		S	H		Walk parallel to MILES, carrying 12-in piece of iron
		84/50	UB			Tape controller
	C29-C63	84/51	UB			Tape controller
	C64-C68	84/52	UB			Tape controller
	CAL #10	84/52				
4353	CAL #10	84/52				
	C69-C92	84/52	UB			Tape controller
	C93-C106	84/53	UB			
	C107-C124	84/54	UB			
	C125-C146	84/55	UB			
	C147-C172	84/56	UB			
	C173-C196	84/57	UB			
<u>CRREL, Fall 1984</u>						
4580	CAL #10	84/269				
	505-506	84/270	B			Loaded dump truck from quarry
	507		B			
	508-518		S			Foil ball, Racon drag
	519-525		S			FPS drop hammer
	526-527		S	H		Sentrax CL walk
	528		B			
	529-538		W	H		
	539-543		C	H		
	544-548		D	H		
	549-553		G	H		
	554-557		W	H		
	558-561		R	H		
	562-565		C	H		
	566-569		D	H		
	570-573		C	H		
	574		B			
	575	84/271	B			
	576-577		B		L	Jeep in background
	578-587		W	H	L	
	588-597		R	H	L	
	598		B			
	599-608		C	H	L	

(Continued)

(Sheet 5 of 11)

Table 2. (Continued).

<u>Tape No.</u>	<u>Test No.</u>	<u>Julian Date</u>	<u>Type</u>	<u>Weight</u>	<u>Background</u>	<u>Description/Comments</u>
<u>CRREL, Fall 1984 (Continued)</u>						
4580	609-618		G	H	L	
Cont.	619-628		W	H	L	
	CAL #11	84/271				
4581	CAL #11	84/271				
	629-637		DW	H	L	
	638-645		DG	H	L	
	646-653		DR	H	L	
	654-661		DC	H	L	
	662-669		DD	H	L	
	670-674		B		L	
	675-676	84/272	B			Gravel pit in operation
	677-680		B		H	5-ton truck at 20 m
	681		X			Jarring of Racon post
	682-695		W	H	H	
	696-713		C	H	H	
	714-723		D	H	H	
	724-725		B			
	726-735		R	H	H	
	736-745		G	H	H	
	746-753		DW	H	H	
	754-761		DG	H	H	
	762-769		DD	H	H	
	770-777		DR	H	H	
	778-785		DC	H	H	
	786-788		B		H	Truck at 20 m
	789	84/272	B			
	790	84/273	B			
	791-792		B		L	Jeep at 20 m
	793-806		W	L	L	
	807-818		R	L	L	
	819-828		C	L	L	
	829		B			Truck exiting from quarry
	830-839		D	L	L	
	840		B			
	841-848		DW	L	L	
	849-858		DC	L	L	
	859-864		DR	L	L	
4804	CAL #12	84/273				
	865		B			
	866-867		X			Sentrax walk
	868	84/274	B			
	869-870		B		H	
	871-880		W	L	H	

(Continued)

(Sheet 6 of 11)

Table 2. (Continued).

<u>Tape No.</u>	<u>Test No.</u>	<u>Julian Date</u>	<u>Type</u>	<u>Weight</u>	<u>Background</u>	<u>Description/Comments</u>
<u>CRREL, Fall 1984 (Continued)</u>						
4804	881-890		C	L	H	
Cont.	891-900		D	L	H	
	901-910		R	L	H	
	911-920		G	L	H	
	921		B			
	922-926		W	L		
	927-931		C	L		
	932-936		D	L		
	937-941		R	L		
	942-946		G	L		
	CAL #13	84/274				
4805	CAL #13	84/274				
	947-951		DW	L		
	952-955		DC	L		
	956-959		DD			
	961-962		DR	L		
	963		B			Airplane
	964		DR	L		
	965-968		DG	L		
	969-970		X	L		Sentrax walk
	971-976		DW	L	H	
	977-982		DC	L	H	
	983-988		DR	L	H	
	989		B			
	990-992	84 275	B			
	993	84 276	B			Raining
	994-997			X	H	Sentrax walk
	998		S			Calibrated creeper
	999-1000		X			Sentrax walk
	1001-1005		W	H		
	1006-1010		C	H		
	1011-1020		R	H		
	1021		B			
	1022	84 276	B			
4805	CAL #14					
	1023		X			Random noise signal
4806	1024	84 277	X			Random noise signal
	CAL #14					
	1025-1026		B			
	1027	84 278	B			
	1028-1033		B			Fast dump walk
	1034		B			
	1035-1040		B			



Table 2. (Continued).

<u>Tape No.</u>	<u>Test No.</u>	<u>Julian Date</u>	<u>Type</u>	<u>Weight</u>	<u>Background</u>	<u>Description/Comments</u>
<u>CRREL, Fall 1984 (Continued)</u>						
4806	1041-1042		X		H	Sentrax walk
Cont.	1043		X			Cal anemometer
	1044-1045		X		H	Sentrax walk
	1046		B			
	1047	84/279	B			
	1048-1061		S			Boy and small dog
	1062-1063		X	H		Sentrax walk
	1064-1069		B		H	
	1070		S	H		E-field target
4807	1071-1072		X			Sentrax walk
	1073/ CAL#15					
	1074-1085		S			Calibrated creeper
	1086		B			
	1087	84/280	B			
	1088-1089		X	H		Sentrax walk
	1090-1091		X	L		Sentrax walk
	1092		MW	L		Two intruders
	1093		MC	L		
	1094		MW	L		
	1095		MC	L		
	1096		MW	L		
	1097		MC	L		
	1098		MW	L		
	1099		MC	L		
	1100		MW	L		Three intruders
	1101		MC	L		Two intruders
	1102-1103		MW	LH		Three intruders
	1104		MC	LH		Three intruders
	1105		X			Hammer swing over MILES
	1106		MC	LH		Three intruders
	1107		MW	LH		Two intruders
	1108		MW	L		
	1109		MC	L		
	1110		MW	L		
	1111		MC	L		
	1112		MW	L		
	1113		MC	L		
	1114		MW	L		
	1115		MC	L		
	1116		MW	L		Three intruders
	1117		MC	L		Three intruders
	1118		MW	L		Three intruders

(Continued)

(Sheet 8 of 11)

Table 2. (Continued).

<u>Tape No.</u>	<u>Test No.</u>	<u>Julian Date</u>	<u>Type</u>	<u>Weight</u>	<u>Background</u>	<u>Description/Comments</u>
<u>CRREL, Fall 1984 (Continued)</u>						
4807	1119-1122		MR	L		Three intruders
Cont.	1123		MG	L		Three intruders
	1124-1127		MG	L		Two intruders
	1128-1129		B	L		
	1130-1131		MW	L	L	Three intruders
	1132-1133		MC	L	L	Three intruders
	1134-1135		MR	L	L	Three intruders
	1136-1137		MG	L	L	Three intruders
	1138-1139		MW	L	L	Two intruders
	1140-1141		X	H		Sentrax walk
	1142		B			
4808	1143-1144	84/280	MW	L	L	Two intruders
	1145-1146		MC	L	L	
	1147-1148		MR	L	L	
	1149-1150		MG	L	L	
	1151-1152		MW	L	L	
	1153-1154		MC	L	L	
	1155-1156		MR	L	L	
	1157-1158		MG	L	L	
	1159-1160		MW	L	L	
	1161-1162		MC	L	L	
	1163-1164		MR	L	L	
	1165-1166		MG	L	L	
	1167-1168		MW	L	L	
	1169-1170		MC	L	L	
	1171-1172		MR	L	L	
	1173-1174		MG	L	L	
	1175-1184		G	L	L	
	1185-1190		DD	L	L	
	1191-1192		DG	L	L	
	1193-1194		DD	L	L	
	1195-1196		DG	L	L	
	1197-1203		S			Foil target
	1204-1205		B		H	
	1206-1207		W	L	H	
	1208-1209		MC	L	H	Two intruders
	1210-1211		MW	L	H	Two intruders
	1212-1213		MC	L	H	Two intruders
	1214		B			
	1215	85/281	B			
	1216-1217		X	H		Sentrax walk
	1218-1222		S			Medium-size dog and handler
	CAL #16					

(Continued)

(Sheet 9 of 11)

Table 2. (Continued).

<u>Tape No.</u>	<u>Test No.</u>	<u>Julian Date</u>	<u>Type</u>	<u>Weight</u>	<u>Background</u>	<u>Description/Comments</u>
<u>CRREL, Fall 1984 (Continued)</u>						
4814	CAL #16	85/281				
	1223-1224		MW	L	H	Two intruders
	1225-1226		MC	L	H	
	1227-1228		MW	L	H	
	1229-1230		MC	L	H	
	1231-1232		MW	L	H	
	1233-1234		MC	L	H	
	1235-1236		MR	L	H	
	1237-1238		MG	L	H	
	1239-1240		MR	L	H	
	1241-1242		MD	L	H	
	1243-1246		MR	L	H	
	1247		MW	LH		Three intruders
	1248		MC	LH		
	1249		MR	LH		
	1250-1251		MR	LH	H	
	1252-1253		MC	LH	H	
	1254-1255		MR	LH	H	
	1256		MW	LH		Two intruders
	1257		MC	LH		
	1258		MR	LH		
	1259		MW	LH		
	1260		MC	LH		
	1261		MR	LH		
	1262		MW	LH		
	1263		MC	LH		
	1264		MR	LH		
	1265-1266		MW	LH	H	
	1267-1268		MC	LH	H	
	1269-1270		MR	LH	H	
	1271-1272		MW	LH	H	
	1273-1274		MC	LH	H	
	1275-1276		MR	LH	H	
	1277-1278		MW	LH	H	
	1279-1280		MC	LH	H	
	1281-1282		MR	LH	H	
	1283-1284		B		H	
	1285		B			
	1286	84/282	B			
	1287		W	H		
<u>CRREL, Winter 1985</u>						
4815	1895	85/34	X			Shovel swing over miles
	1896-1898		W	L		

(Continued)

(Sheet 10 of 11)

Table 2. (Concluded).

<u>Tape No.</u>	<u>Test No.</u>	<u>Julian Date</u>	<u>Type</u>	<u>Weight</u>	<u>Background</u>	<u>Description/Comments</u>
<u>CRREL, Winter 1984 (Concluded)</u>						
4815	1899-1902		C	L		
Cont.	1903-1906		R	L		
	1907		W	H		
	1908-1909		B		L	Jeep at 15 m
	1910-1922		W	L	L	
	1923-1926		C	L	L	
	1927-1930		R	L	L	
	1931-1932		S	L		Sentrax walk
	1933-1936		W	H	L	
	1937-1940		C	H	L	
	1941-1944		R	H	L	
	1945-1946		B		L	
	1947		B			
	1948-1951		W	H		
	1952-1955		R	H		
	1956-1959		C	H		
	CAL #21					
	1960-1961		S			Sentrax walk
	CAL #22					
"C"	CAL #22					
	1962	85/34	B			7250' BKGND, XCRREL "C"
"D"	CAL #23	85/35				
	1963-1966	85/35	S			Foil ball, Racon
	1967		W	H		
	1968-1970		S			Foil ball, Racon
	1971-1974		DW	H		
	1975		S			Calibrated creeper
	1976-1977		B			
	1978-1979		S	H		Sentrax walk
	1980		B			0 - night background
4816	CAL #24	85/36				
	1981		W	H		
	1982		X			Cut E-field wires

## SECTION 5

### CONCLUSIONS AND RECOMMENDATIONS

#### 5.1 CONCLUSIONS.

The analog recorder system used during this study was adequate for collecting a large volume of data, particularly continuous data collected over a period of several hours. The frequency response of the tape recording equipment and instrumentation was responsive from DC to greater than 1,500 Hz.

A digital computer data collection system programmed to initiate data collection under specific ranges of environmental conditions, background noises, intruder modes, etc., could improve data processing, intrusion sensor annunciator systems testing, and alarm system evaluation by allowing rapid accurate reproduction of sensor signatures that produce alarm and nuisance alarm conditions.

Support sensors were generally adequate for recording impulse meteorological events, or meteorological events of short duration. The analog anemometer and wind direction indicator performed well, as did the direct recording of rain bucket impulses. The lightning detector performed exceptionally well. The simultaneous collection of quantitative lightning data and perimeter security sensor systems' response to lightning could be useful in designing circuitry or software to mitigate the effects of lightning on security system annunciators.

The support sensor system for long-term monitoring of environmental conditions changes was inadequate. The Campbell meteorological station proved to be unreliable, and the use of audio cassette recording of digital data is unsatisfactory because tone frequency encoding of the data is dependent upon not only individual cassette recorders, but also the supply battery voltage to the cassette recorder.

The perimeter security system sensor signature data base collected covers two major weather seasons at FBBI and multiple samples of temperature, humidity, and pressure. The range of data collected on the temperature, humidity, and pressure data base is seasonal variation at a wide range of humidity and pressure and through wide temperature variations.

## 5.2 RECOMMENDATIONS.

Recommendations for future research in multiple-sensor data base development are as follows:

- a. Testing should be accomplished on more than two zones.
- b. Testing and threshold characterizations should be accomplished during a freeze/thaw cycle and a thawed-to-frozen cycle.
- c. Software should be developed to allow emulation of more than two security zones using the Masscomp computer system.
- d. Attention should be directed to developing mobile site characterization equipment that will allow recording spurious events/data, particularly at industrial-type sites.
- e. Hardware should be developed to allow ground-truthing of intruder location within the sensor field.
- f. Meteorological equipment suitable for long-term monitoring of environmental changes should be developed and installed.

## REFERENCES

- Ballard, J. H., and Miller, C. A. 1985 (Aug). "Effects of Soil State and Geometry on Leaky Coaxial Cable Sensor Response," Technical Report EL-85-14, US Army Engineer Waterways Experiment Station, Vicksburg, MS.
- Benn, B. O., and Link, L. E. 1972 (Apr). "Effects of Environment on Seismic Intrusion Detector Performance; A Preliminary Report," Miscellaneous Paper M-72-4, US Army Engineer Waterways Experiment Station, Vicksburg, MS.
- Benn, B. O., and Smith, P. A. 1975 (Jan). "A Guide for Collecting Seismic, Acoustic, and Magnetic Data for Multiple Uses," Technical Report M-75-2, US Army Engineer Waterways Experiment Station, Vicksburg, MS.
- Cress, D. H. 1978 (May). "Terrain Considerations and Data Base Development for the Design and Testing of Devices to Detect Intruder-Induced Ground Motion," Technical Report M-78-1, US Army Engineer Waterways Experiment Station, Vicksburg, MS.
- Harman, R. K. 1982 (May). "Advancements in Leaky Cable Technology for Intrusion Detection," 1982 Canadian Conference on Security Technology, University of Kentucky, Lexington, KY.
- \_\_\_\_\_. 1983 (May). "Sentrax--A Perimeter Security System," 1983 Conference on Crime Countermeasures, University of Kentucky, Lexington, KY.
- Honeywell Defense Systems Division. 1979 (Mar). "BLS 1000, BURIED LINE SENSOR, Technical Data and Installation Instructions," Tactical Support Center, St. Petersburg, FL.
- Link, L. E., West, H. W., and Benn, B. O. 1972 (Jun). "Seismic and Environmental Characteristics of Sensor Test Areas in the Panama Canal Zone; Report 1: Dry Season Conditions," Technical Report M-72-2, US Army Engineer Waterways Experiment Station, Vicksburg, MS.
- Marcuson, W. F., III, and Leach, R. E. 1973 (May). "Seismic and Environmental Characteristics of Sensor Test Areas in the Panama Canal Zone; Report 2: Wet Season Conditions," Technical Report M-72-2, US Army Engineer Waterways Experiment Station, Vicksburg, MS.
- Miller, C. A. 1978 (Jun). "Preinstallation Survey Guide for MAID/MILES System," Miscellaneous Paper M-78-6, US Army Engineer Waterways Experiment Station, Vicksburg, MS.
- \_\_\_\_\_. 1979 (Apr). "Effects of Freezing Temperatures and Frozen Ground Conditions on Enclosed Wire-in-Tube Response," Miscellaneous Paper M-79-2, US Army Engineer Waterways Experiment Station, Vicksburg, MS.
- Miller, C. A. and Ballard, J. H. 1981 (Nov). "Environmental Constraints on the Ported Coaxial Cable Sensor (PCCS) (U)," Technical Report EL-81-10, US Army Engineer Waterways Experiment Station, Vicksburg, MS.
- Racon, Inc. 1977. "Installation, Operation and Maintenance Manual," Document No. 10006-007-04(C), Seattle, WA.
- Senstar Corporation. 1982a (Feb). "Sentrax Operating Guide (Preliminary)," Kanata, Ontario, Canada.
- \_\_\_\_\_. 1982b (Apr). "Sentrax Installation Manual (Preliminary)," Kanata, Ontario, Canada.

\_\_\_\_\_. 1983. "Sentrax Maintenance Manual, Sentax 1 Perimeter Security System, Draft 1," Kanata, Ontario, Canada.

Starr, J. B. 1976 (Aug). "Energy Propagation and Coupling Studies for Line Transducers," Final Technical Report, USAE Contract F30602-75-C-0186, FRADC-RE-76-239 (A031741), Honeywell Defense Systems Division, Hopkins, MN.

Stellar Systems. Undated. "Maintenance Manual, Single and Dual Zone Control Units, E-Field Perimeter Protection System," FN 78-8/4/79, Santa Clara, CA.

\_\_\_\_\_. 1980 (Nov). "Installation Manual, Single and Dual Zone Control Units, E-Field Perimeter Protection System, FN 78-8/4/79, Santa Clara, CA.

Sylvania (GTE), Inc. 1978 (Aug). "Installation and Operating Instructions, Fence Protection System, FPS-2," Electronic System Group-Western Division, Mountain View, CA.

US Air Force. 1983 (Jan). "Siting Criteria for SAFE Programs," SAFE-SIT-0001 (Change 3), prepared by Deputy for Surveillance and Control, Physical Security Systems Directorate, Electronic Systems Division, Air Force Systems Command, Hanscom Air Force Base, MA.

Zappi, M. A. 1978 (Jan). "Status Report for Selection of Sites for Background Noise Signature Data Development," Miscellaneous Paper M-78-1, US Army Engineer Waterways Experiment Station, Vicksburg, MS.



DISTRIBUTION LIST

Scott Air Force Base  
ATTN: COL Douglas A. Abbott

US Army Cold Regions Research and  
Engineering Laboratory  
ATTN: Mr. Donald G. Albert

US Army Air Defense School  
ATTN: ATSA-CDM-C (Mr. Pete Baker)

University of Mississippi  
ATTN: Dr. Henry Bass

US Army Corps of Engineers  
ATTN: DAEN-RDM (Mr. Bob O. Benn)

US Army Engineer Division, Huntsville  
ATTN: HNDED-PM (Mr. Philip D. Brown)

Naval Electronics Systems Engineering  
Center  
ATTN: Mr. James E. Broyles

US Army Engineer Division, Huntsville  
ATTN: HNDED-ME (Mr. Frank Carlen)

Sandia National Laboratories  
ATTN: Mr. Glenn R. Elliott

US Army Corps of Engineers  
ATTN: DAEN-ECE-E (Mr. Robert Fite)

Sandia National Laboratories  
ATTN: Mr. Robert Joseph Fogler

US Army Construction Engineering  
Research Laboratory  
ATTN: Mr. Paul Howdyshell

US Army Human Engineering Laboratory  
ATTN: SLCHE-BR (Dr. Kalb)

US Army Electronic Proving Ground  
ATTN: STEEP-DT-DS  
(Mr. Richard C. Keller)

Norton Air Force Base  
ATTN: CPT Ernest Krausman

US Army Cold Regions Research and  
Engineering Laboratory  
ATTN: Dr. L. E. Link,  
Technical Director

Naval Electronic Systems  
Engineering Center  
ATTN: 501 FM/727 (Mr. Frank Mazzone)

US Army Construction Engineering  
Research Laboratory  
ATTN: CERL-EM (Mr. Ray G. McCormack)

US Army Field Artillery Board  
ATTN: ATZR-BDT (Mr. Eugene Minietta)

Program Manager, REMBASS  
ATTN: AMCPM-RB

Sandia National Laboratories  
ATTN: Mr. John L. Mitchner

US Army Research Office  
ATTN: Dr. Steven J. Mock

Marine Corps Development and  
Education Command  
ATTN: Intelligence Division,  
Code D-023

US Army Intelligence Center and School  
ATTN: ATSI-CD-CS

Defense Nuclear Agency  
ATTN: NSNS

Hanscom Air Force Base  
ATTN: ESD/OCB (Mr. Neil Anderson)

US Army Cold Regions Research and  
Engineering Laboratory  
ATTN: Dr. Lindamae Peck

US Army Intelligence Center and School  
ATTN: ATSI-TSM-AS  
(MAJ Stephen V. Reeves)

US Army Armament Research and  
Development Command  
ATTN: Mr. Clifford D. Shook

Sandia National Laboratories  
ATTN: Mr. Basil Steele

US Army Field Artillery School  
ATTN: ATSF-CMS (Mr. Charles Taylor)

General Research Corporation  
ATTN: Dr. Richard Bartek

END

11-87

DTIC