

REPORT NO. T13-87

DEVELOPMENT OF A TISSUE FREEZING AND REWARMING DEVICE THAT USES COMPRESSED AIR AS A MEDIUM

AD-A184 982

By

Mark W. Sharp SSG, Neil W. Ahle CPT,
Rodrigo A. Mariano SGT and William Sawyer SGT

May 4, 1987

DTIC
ELECTE
SEP 25 1987
S D
D



DISTRIBUTION STATEMENT A
Approved for public release
Distribution Unlimited

US ARMY RESEARCH INSTITUTE OF ENVIRONMENTAL MEDICINE

NATICK, MA 01760

87 9 23 023

The findings in this report are not to be construed as an official Department of the Army position, unless so designated by other authorized documents.

DISPOSITION INSTRUCTIONS

Destroy this report when no longer needed.

Do not return to the originator.

AD 2124 982

REPORT DOCUMENTATION PAGE

Form Approved
OMB No. 0704-0188

1a. REPORT SECURITY CLASSIFICATION UNCLASSIFIED		1b. RESTRICTIVE MARKINGS	
2a. SECURITY CLASSIFICATION AUTHORITY		3. DISTRIBUTION / AVAILABILITY OF REPORT Approved for public release; distribution is unlimited	
2b. DECLASSIFICATION / DOWNGRADING SCHEDULE			
4. PERFORMING ORGANIZATION REPORT NUMBER(S)		5. MONITORING ORGANIZATION REPORT NUMBER(S)	
6a. NAME OF PERFORMING ORGANIZATION U.S. Army Res. Inst. of Environmental Medicine	6b. OFFICE SYMBOL (if applicable) SGRD-UE-MEP	7a. NAME OF MONITORING ORGANIZATION U.S. Army Research Institute of Environmental Medicine	
6c. ADDRESS (City, State, and ZIP Code) Kansas Street Natick, MA. 01760-5007		7b. ADDRESS (City, State, and ZIP Code) Kansas Street Natick, MA. 01760-5007	
8a. NAME OF FUNDING / SPONSORING ORGANIZATION	8b. OFFICE SYMBOL (if applicable)	9. PROCUREMENT INSTRUMENT IDENTIFICATION NUMBER	
8c. ADDRESS (City, State, and ZIP Code)		10. SOURCE OF FUNDING NUMBERS	
		PROGRAM ELEMENT NO.	PROJECT NO. 3E162 777A879
		TASK NO.	WORK UNIT ACCESSION NO. 124
11. TITLE (Include Security Classification) (U) Development of a Tissue Freezing and Rewarming Device that uses Compressed Air as a Medium.			
12. PERSONAL AUTHOR(S) Mark W. Sharp SSG, Neil W. Ahle CPT, Rodrigo A. Mariano SGT, William Sawyer SGT			
13a. TYPE OF REPORT Technical Report	13b. TIME COVERED FROM _____ TO _____	14. DATE OF REPORT (Year, Month, Day) 1987, May, 04	15. PAGE COUNT 9
16. SUPPLEMENTARY NOTATION			
17. COSATI CODES		18. SUBJECT TERMS (Continue on reverse if necessary and identify by block number)	
FIELD	GROUP	Frostbite, Swine, Frostbite Model, Freezing Chamber	
19. ABSTRACT (Continue on reverse if necessary and identify by block number)			
<p>This report describes a tissue cooling/rewarming system (TCRS) which uses dried, super-cooled, compressed air as a medium. It allows the user, in a manner close to that which occurs in a natural arctic environment, to freeze and rewarm animal tissue producing the first three degrees of frostbite. Temperature, wind speed and time of freeze can all be varied. The TCRS consist of an air compressor, air dryer, air jet cooler with controller, and a acrylic animal tissue freezing chamber. Temperatures are monitored by utilizing the Hewlett Packard 3054 A Data Acquisition System, which is driven by the Hewlett Packard 236 table top computer. The TCRS has been used to produce approximately 500 precisely controlled frostbite injuries to date. This TCRS should prove to be a useful means of developing a reproducible, realistic, animal frostbite model. ←</p>			
20. DISTRIBUTION / AVAILABILITY OF ABSTRACT <input checked="" type="checkbox"/> UNCLASSIFIED/UNLIMITED <input type="checkbox"/> SAME AS RPT. <input type="checkbox"/> DTIC USERS		21. ABSTRACT SECURITY CLASSIFICATION UNCLASSIFIED	
22a. NAME OF RESPONSIBLE INDIVIDUAL MARK W. SHARP SSG		22b. TELEPHONE (Include Area Code) (617) 651-4867	22c. OFFICE SYMBOL SGRD-UE-MEP

DISCLAIMER STATEMENT

The views, opinions, and/or findings contained in this report are those of the authors and should not be construed as official Department of the Army position, policy, or decision, unless so designated by other official documentation. In conducting the research described in this report, the investigators adhered to the "Guide for Laboratory Animal Facilities and Care," as promulgated by the Committee on the Guide for Laboratory Animal Facilities and Care of the Institute of Laboratory Animal Resources, National Academy of Sciences, National Research Council.



Accession For	
NTIS CR&I	<input checked="" type="checkbox"/>
DTIC TAB	<input type="checkbox"/>
Unannounced	<input type="checkbox"/>
Justification	
By	
Distribution of	
Availability of	
Dist	Availability of
A-1	Continued

TECHNICAL REPORT

NO. T13-87

DEVELOPMENT OF A TISSUE FREEZING AND REWARMING
DEVICE THAT USES COMPRESSED AIR AS A MEDIUM

by

Mark W. Sharp SSG, Neil W. Ahle CPT,
Rodrigo A. Mariano SGT and William Sawyer SGT

US Army Research Institute of Environmental Medicine
Natick, Massachusetts 01760

TABLE OF CONTENTS

	<u>Page</u>
List of Figures	iv
Abstract	v
Introduction	1
The Production of Super Cooled or Warm Air	2
The Acrylic Animal Tissue Freezer	4
The Data Acquisition System	4
The Animal Model	7
Discussion	7
References	9

List of Figures

	<u>Page</u>
Fig.1	3
Fig.2	5
Fig.3	6
Fig.4	6

ABSTRACT:

This report describes a tissue cooling/rewarming system (TCRS) which uses dried, super-cooled, compressed air as a medium. It allows the user, in a manner close to that which occurs in a natural arctic environment, to freeze and rewarm animal tissue producing the first three degrees of frostbite. Temperature, wind speed and time of freeze can all be varied. The TCRS consists of an air compressor, air dryer, air jet cooler with controller, and a acrylic animal tissue freezing chamber. Temperatures are monitored by utilizing the Hewlett Packard 3054A Data Acquisition system, which is driven by the the Hewlett Packard 236 table top computer. The TCRS has been used to produce approximately 500 precisely controlled frostbite injuries to date. This TCRS should prove to be a useful means of developing a reproducible, realistic, animal frostbite model.

INTRODUCTION:

Frostbite research has long suffered from the lack of a reproducible freezing method that mimics a natural arctic environment. Frostbite investigators have used many different methods to produce frostbite injuries. Examples of such methods include: direct contact liquid nitrogen cooling (1), direct contact immersion in a super-cooled bath (2), tissue protected by a barrier and then immersed into a liquid medium (3), and a method using a previously chilled branding iron (4). Limited control of the cooling variables and the exclusion of a wind chill factor prohibits any of the above methods from generating a realistic, reproducible animal frostbite model. To obtain such a model, a freezing technique, with precise cooling controls that is capable of mimicking an arctic environment is needed.

The objective of this report is to describe, (1) the means of producing super cooled or warm air as a medium for generating frostbite and rewarming the injured tissue, (2) the chamber that is deployed in freezing the tissue, (3) the methods of monitoring the temperature, flow rates, and duration of the freeze, and (4) the animal model and anesthetic that was utilized.

The Production of Super Cooled or Warm Air

The cooling or warming of air is accomplished by a system comprised of four components: a Quincy Model 5120 air compressor, a FTS model AD-80 Air Dryer, a FTS model XR-85-1 Air-Jet Crystal Cooler and a FTS model TC-44 Temperature Controller. The compressor requires 220 volts and has the capacity of providing 50 cubic feet per minute at 120 PSI. The air dryer operates on 115 volts and is capable of reducing 100 psi compressed air to a dew point of -80 degree centigrade. The air dryer contains a pressure regulator, pressure gauge, oil and particle filter and a heatless regenerative dryer. The dried air flow rate can be adjusted from .1 to 6 cfm. All flow rates were verified by utilizing a Alnor Velometer type 3002. After the air is dried it is then directed to the Air-Jet Cooler. The Air-Jet Cooler provides the cooling or warming of dry air. A thermocouple located in the nozzle is connected to a remote digital indicator/controller where the temperature is continuously displayed to 0.1 degree centigrade. A potentiometer is rotated to set any temperature over the range to the nearest 0.1 degree centigrade. The fast cycle rate controller provides power to the heater to bring the nozzle temperature to a previously determined set point. The controller

contains circuitry to prevent overshooting and automatic reset to provide control accuracy to ± 0.1 degree centigrade. The air flow can be adjusted from .1 to a maximum of 6 cfm although this alters the maximum and minimum achievable temperature range. (See fig.1.)

Maximum and Minimum Temperature Limits for the TCRS

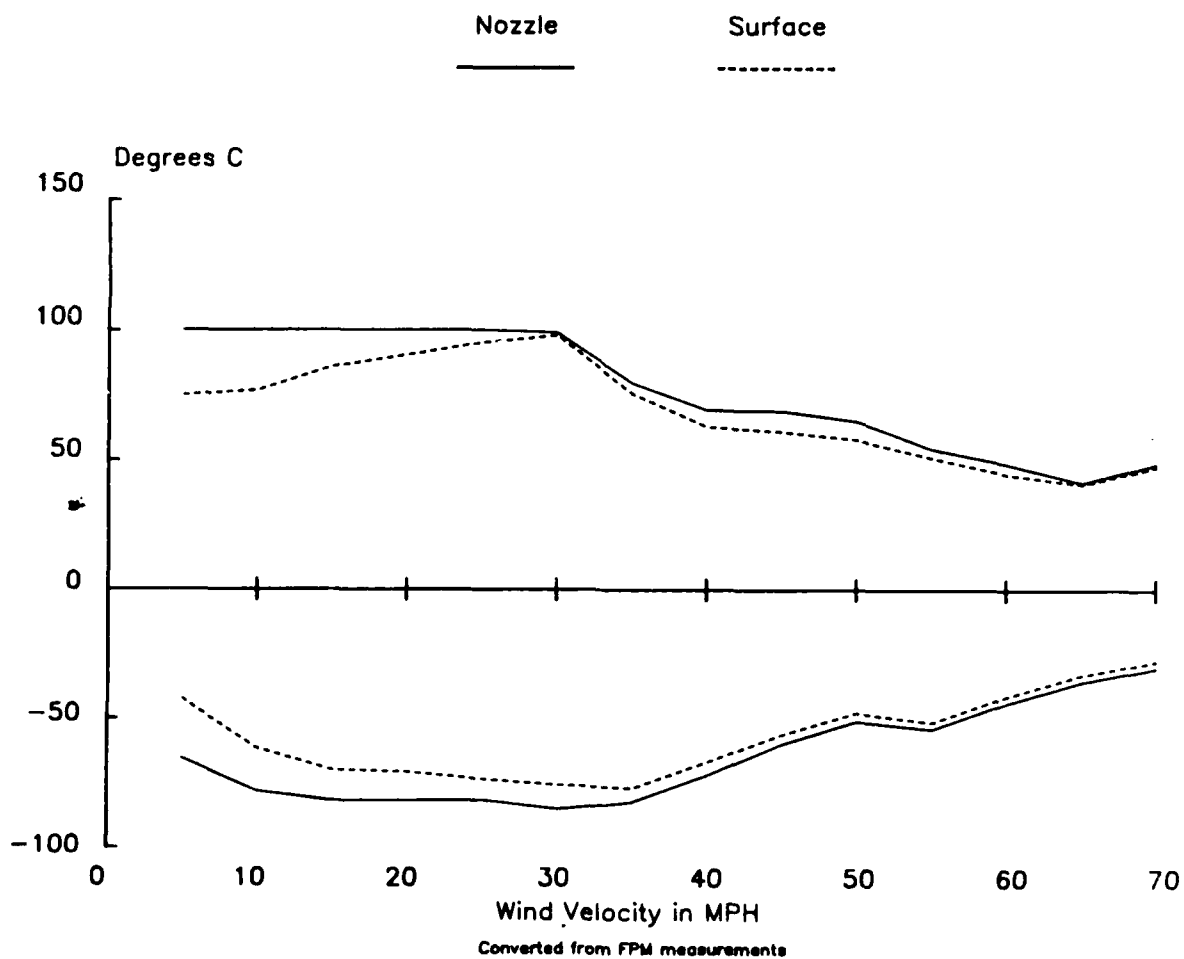

The Acrylic Animal Tissue Freezer

The Acrylic Animal Tissue Freezer, (AATF) was fabricated by the Biomedical Engineering Branch of the United States Army Institute of Environmental Medicine. (See fig.2.) The AATF is attached over the intended freeze area by utilizing double stick tape, model #A-20 tape #4016, manufactured by 3M, (St. Paul, Minnesota). A 7mil. paper air baffle was fabricated for the base of the AATF that would divert expelled air and reduce the possibility of accidentally freezing the surrounding tissue. This baffle was critical when freezing soft, easily depressed areas of the animal. (See fig.3&4)

The Data Acquisition System

The data acquisition system is comprised of four components: (1) a Hewlett Packard 3054A Data Acquisition system, (2) a Hewlett Packard 236 table top computer, (3) a Hewlett Packard Think Jet Printer, and (4) three different models of Omega T-type thermocouples. The three models deployed were the: (1) Omega Veterinary Implantation Probes used to measure rectal temperatures, (2) Omega HYP-0 used to measure intradermal temperatures, and (3) the Omega Insulated Teflon/Teflon .005 Dia. thermocouples utilized to

ACRYLIC ANIMAL TISSUE FREEZER

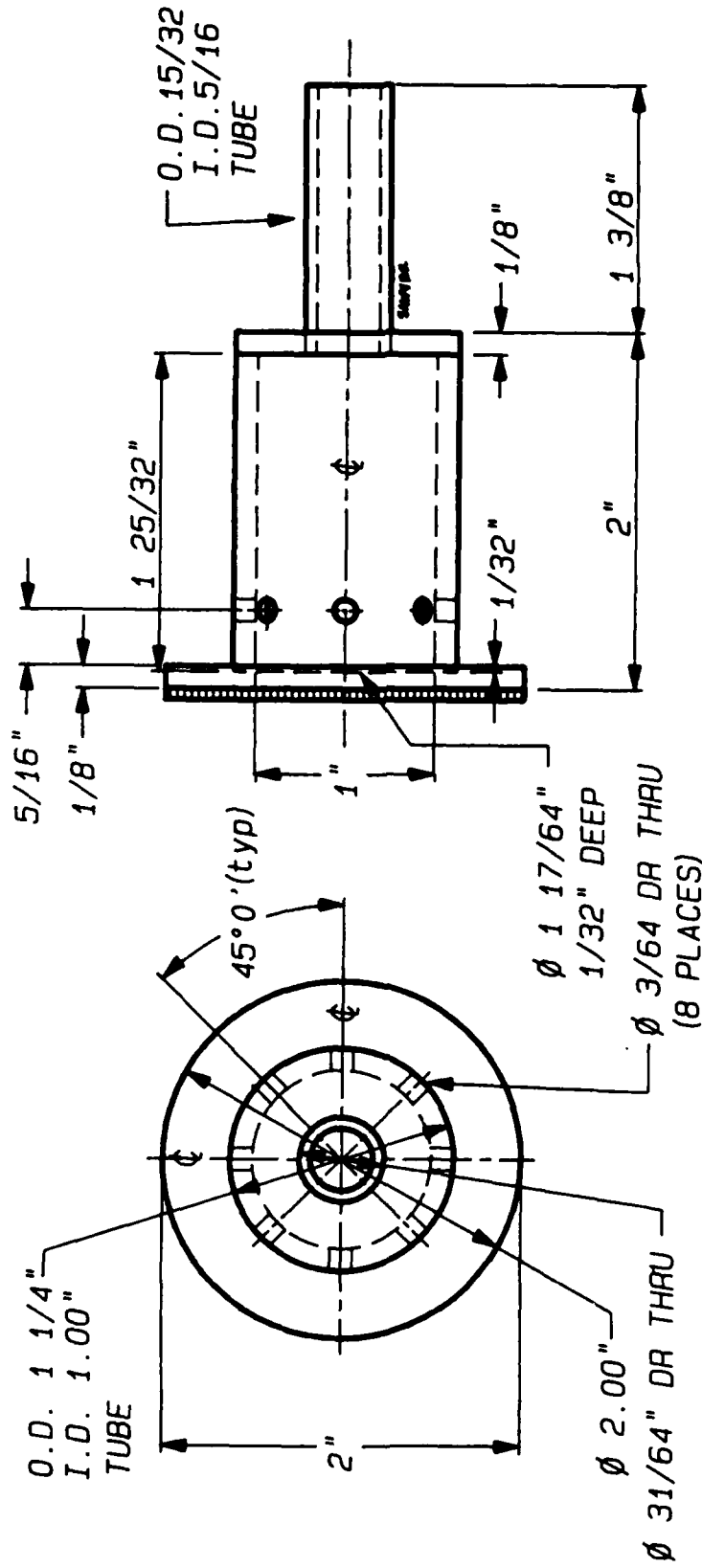

MATERIALS:

1. Acrylic body construction
2. Paper baffle, 7 mils thick see fig. 3 & 4
3. Acrylic adhesive (trichloroethane)
4. Tape, urethane foam, double coated .065" thick

FIG 2

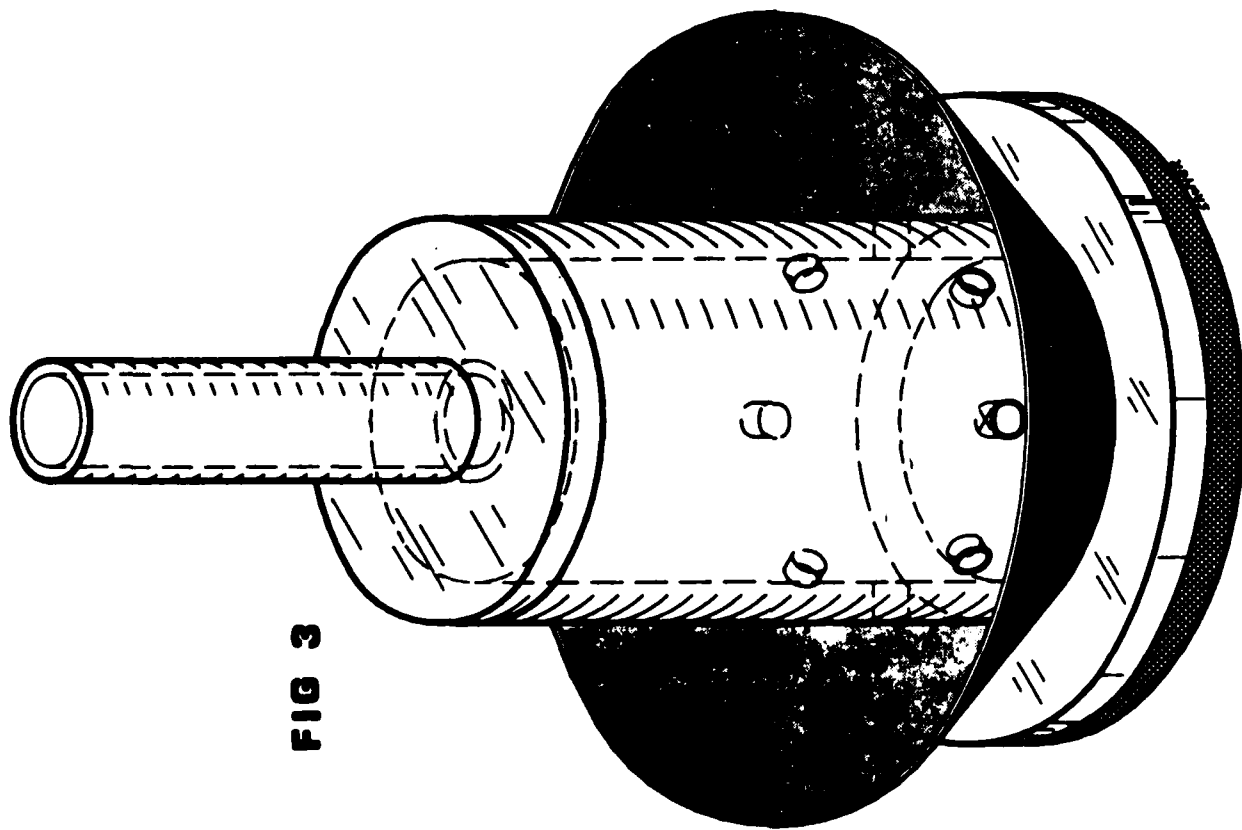

FIG 3

ORTHOGRAPHIC VIEW

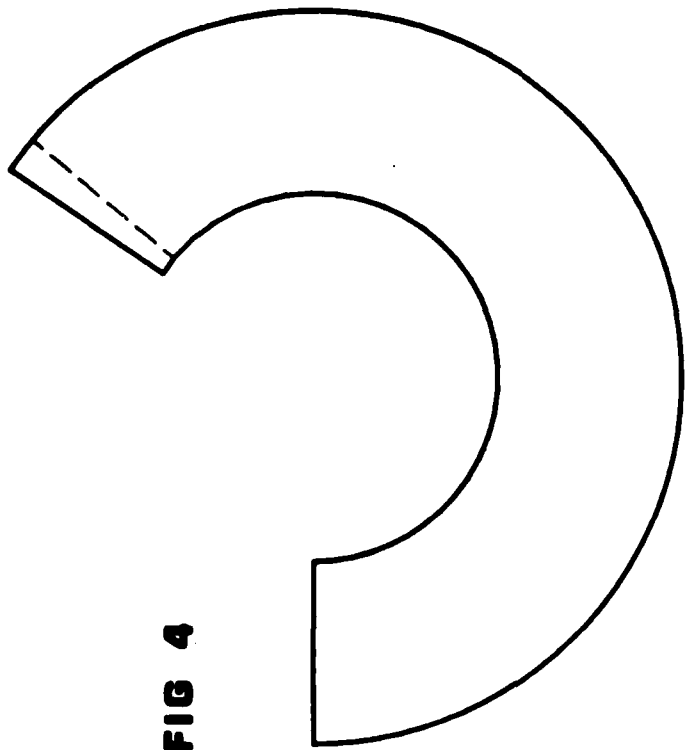

FIG 4

**BAFFLE PATTERN
(actual size)**

measure skin, AAFT, air jet nozzle, and ambient temperatures. The computer is programmed to read the thermocouples every 4.5 seconds. A hard copy of the time and temperature information is generated by utilizing the HP Think Jet Printer. Simultaneously the same information is stored on one of the computer's internal 5-1/4 inch floppy disc drives for later analysis.

The Animal Model

The animal model that was selected was the Hanford (HMS tm) Miniature Swine which is bred by Charles River Breeding Laboratories, Inc. (Willmington, Massachusetts). Two successful methods of anesthesia employed during the freezing process were a Ketamine/Xylazine cocktail (20 mg/kg and 2 mg/kg respectively) given by intramuscular injection, or Halothane delivered by mask to effect. The animals were restrained by the Panepinto Sling Model #DL800, which is manufactured by the Dutton-Lainson Co. (Hasting, Nebraska).

Discussion

Frostbite researchers over the years have tried many different techniques in producing frostbite, most of which had either limited variability in the cooling process or did

not include factors such as wind chill. The AATF will give frostbite investigators a cooling method that has precise cooling controls, and is capable of mimicking a normal arctic environment. By possessing these two unique characteristics this cooling system should give future investigators the vehicle in which to produce a realistic, animal, frostbite model.

REFERENCES

1. Ehrlich, H.P., A.L. Needle, J. Rajaratham, M.E. White, and B.S. White. The Role of Prostacyclin and Thromboxane in Rat Burn and Freeze Injuries. *Experimental and Molecular Pathology*. 38, 357-367, 1983.
2. Lazarus, H.M., and W. Hutto. Electric Burns and Frostbite: Patterns of Vascular Injury. *Journal of Trauma*. 22, #7, 581-585, 1982.
3. Gadarowski, J.J., and J.D. Esce. Acute Systemic Changes in Blood Cells, Proteins, Coagulation, Fibrinolysis, and Platelet Aggregation after Frostbite Injury in the Rabbit. *Cryobiology*. 21, 359-370, 1984.
4. Ehrlich, H.P., R.L. Trelstad, and J.T. Fallon. Dermal Vascular Patterns in Response to Burn or Freeze Injury in Rats. *Experimental and Molecular Pathology*. 34, 281-289, 1981.

DISTRIBUTION LIST

2 Copies to:

Commander
US Army Medical Research and Development Command
SGRD-RMS
Fort Detrick
Frederick, MD 21701

1 Copy to:

Commandant
Academy of Health Sciences, US Army
ATTN: AHS-COM
Fort Sam Houston, TX 78234

1 Copy to:

Dir of Biol & Med Sciences Division
Office of Naval Research
800 N. Quincy Street
Arlington, VA 22217

1 Copy to:

CO, Naval Medical R&D Command
National Naval Medical Center
Bethesda, MD 20014

1 Copy to:

HQ AFMSC/SGPA
Brooks AFB, TX 78235

1 Copy to:

Director of Defense Research and Engineering
ATTN: Assistant Director (Environment and Life Sciences)
Washington, DC 20301

1 Copy to:

Dean
School of Medicine Uniformed Services
University of Health Sciences
4301 Jones Bridge Road
Bethesda, MD 20014