

MICROCOPY RESOLUTION TEST CHART  
NATIONAL BUREAU OF STANDARDS-1963-A

AD-A184 290

①

DTIC FILE COPY

SMSU

CD

ARCHAEOLOGY  
IN THE MISSISSIPPI RIVER FLOODPLA  
AT SAND RUN SLOUGH, IOWA

CAR-690

DTIC  
ELECTE  
SEP 03 1987  
S D  
CD

DISTRIBUTION STATEMENT A  
Approved for public release  
Distribution Unlimited

CENTER FOR  
ARCHAEOLOGICAL  
RESEARCH

87 9 3 042

①

DTIC  
ELECTE  
SEP 03 1987  
S D  
C D

ARCHAEOLOGY  
IN THE MISSISSIPPI RIVER FLOODPLAIN  
AT SAND RUN SLOUGH, IOWA

CAR-690

by

David W. Benn (principal investigator)  
Research Archaeologist

with contributions by:

E. A. Bettis III  
Arthur Hoppin  
Lucretia S. Kelly  
Neal H. Lopinot  
David G. Stanley

A phase III data recovery at site 13LA38  
for the U. S. Army Corps of Engineers,  
Rock Island District,  
under terms of Contract Number DACW25-86-C-0025.

by the

Center for Archaeological Research  
Southwest Missouri State University  
Springfield, Missouri 65804

June 1987

DISTRIBUTION STATEMENT A  
Approved for public release;  
Distribution Unlimited



REPLY TO  
ATTENTION OF:

DEPARTMENT OF THE ARMY  
ROCK ISLAND DISTRICT, CORPS OF ENGINEERS  
CLOCK TOWER BUILDING - P.O. BOX 2004  
ROCK ISLAND, ILLINOIS 61204-2004

August 26, 1987

Planning Division

SEE DISTRIBUTION LIST

We are enclosing the report entitled Archaeology in the Mississippi River Floodplain at Sand Run Slough, Iowa, prepared for us by David Benn from the Center for Archaeological Research under Contract DACW25-86-C-0025. The report covers intensive archaeological investigations at the Sand Run West site (13LA38), Louisa County, Iowa. The purpose of the excavations was to recover significant cultural remains from a stratified Woodland and Late Archaic deposit being eroded by the Mississippi River.

We hope this report is useful for your cultural resource management work along the Mississippi River Valley. The report contains much information on the cultural history of eastern Iowa as well as the Upper Mississippi River Basin. A detailed inventory of the Woodland and Late Archaic occupations is presented, as well as information on the local geomorphological and pedological setting.

If you have any questions, please call Mr. Kenneth Barr at 309/788-6361, Ext. 349, or you may write to the following address:

District Engineer  
U.S. Army Engineer District, Rock Island  
ATTN: Planning Division  
Clock Tower Building - P.O. Box 2004  
Rock Island, Illinois 61204-2004

Sincerely,

J. Paul VanHoorebeke  
Contracting Officer's Representative

Enclosure

**Copy Furnished:**

**Dr. David Benn  
Center for Archaeological Research  
Southwest Missouri State University  
Springfield, Missouri 65804 wo/enclosure**

DISTRIBUTION LIST

Archeology in the Mississippi River Floodplain  
at Sand Run Slough, Iowa

<u>NAME</u>	<u>NO. OF COPIES</u>
Mr. Adrian Anderson Linn County Historical Museum P.O. Box 823 Cedar Rapids, Iowa 52406	1
Mr. Charles J. Bareis Illinois Archeological Survey 396B Davenport Hall University of Illinois Urbana, Illinois 61801	1
Ms. Elizabeth Benchley Board of Regents of University of Wisconsin System Graduate School University of Wisconsin - Milwaukee P.O. Box 340 Milwaukee, Wisconsin 53201	1
Dr. David W. Benn Center for Archaeological Research Southwest Missouri State University Springfield, Missouri 65804-0089	0
Mr. E. Arthur Bettis III Iowa Geological Survey 123 North Capitol Street Iowa City, Iowa 52242	0
Mr. Lawrence Conrad Archeological Research Lab Western Illinois University Macomb, Illinois 61455	1
Mr. David Cook Office of Project Planning Iowa Department of Transportation 800 Lincoln Way Ames, Iowa 50010	1
Mr. David Crosson Iowa State Historic Preservation Officer Historical Building East 12th and Grand Avenue Des Moines, Iowa 50319	2

DISTRIBUTION LIST (Cont'd)

<u>NAME</u>	<u>NO. OF COPIES</u>
Mr. Tom Emerson Illinois Historic Preservation Agency Old State Capitol Springfield, Illinois 62704	1
Mr. Kenneth Farnsworth Center for American Archaeology P.O. Box 22 Kampsville, Illinois 62053	1
Mr. Bill Green Office of State Archaeology Eastlawn Building University of Iowa Iowa City, Iowa 52242	1
Dr. Dale Henning Luther College Decorah, Iowa 52101	1
Mr. Don L. Klima Chief, Eastern Division Project Review Advisory Council on Historic Preservation Old Post Office Building, #809 1100 Pennsylvania Avenue Northwest Washington, D.C. 20004	1
Mr. Michael J. McNerney President American Resources Group, Ltd. 127 North Washington Street Carbondale, Illinois 62901	1
Dr. Joe Nixon Archaeological Survey University of Missouri - St. Louis 2354 Bellerive Drive St. Louis, Missouri 63121	1
Dr. David F. Overstreet Great Lakes Archaeological Research Center P.O. Box 17767 Milwaukee, Wisconsin 53213	1



DISTRIBUTION LIST (Cont'd)

<u>NAME</u>	<u>NO. OF COPIES</u>
Mr. Stanley Riggle Midwest National Technical Information Center Soil Conservation Service 100 Centennial Mall North Federal Building, Room 345 Lincoln, Nebraska 68508	1
Dr. Donna Roper Gilbert Commonwealth 209 East Washington Avenue Jackson, Michigan 49201	1
Mr. David Stanley Highland Cultural Research Center P.O. Box 27 Highlandville, Iowa 52149	0
Dr. John Walthall Chief Archeologist Illinois Department of Transportation Bureau of Location and Environment 2300 South Dirksen Parkway Springfield, Illinois 62704	1
Mr. Michael D. Wiant Illinois State Museum Archeological Lab No. 5 Old Capitol Plaza Springfield, Illinois 62704	1

# CONTENTS

	Page
I. Introduction to the Investigations at Sand Run Slough.....	1
Site Location.....	1
Research Problems.....	3
Previous Investigations.....	6
Natural Setting.....	9
II. Methods, Excavations & Stratigraphy.....	16
13LA38.....	16
13LA30.....	20
Radiocarbon Dates.....	20
Geomorphology, Pedology & Cultural Stratigraphy. with E.A. Bettis III	21
Cultural Features.....	26
III. Ceramic Analysis.....	51
The Ceramic Assemblage.....	51
Body Sherds.....	52
Diagnostic Pottery.....	53
Chronology & Culture Patterns in Ceramics.....	70
Conclusion.....	74
IV. Lithic Analysis.....	101
by David G. Stanley	
Methodology.....	102
Lithic Debitage and Cores.....	102
Flake Tools.....	106
Chipped Stone Tools: Stratum I.....	112
Chipped Stone Tools: Stratum II.....	122
Chipped Stone Tools: Stratum III.....	133
Discussion.....	147
V. Analysis of Fire-Cracked Rock, Ground Stone and Metal.....	188
Unmodified Cobbles & Fire-Cracked Rocks.....	188
Ground Stone & Metal Items.....	189
Discussion.....	194
VI. Archaeobotany.....	203
by Neal H. Lopinot	
Analysis Methods.....	203
Results.....	205
Summary.....	217
Addendum.....	220



A-1

VII. Faunal Remains.....	226
with Lucretia S. Kelly	
The Assemblage.....	226
Discussion.....	229
VIII. Interpretations.....	236
Site Preservation and Natural Contexts.....	236
Culture Patterns.....	239
IX. Recommendations.....	261
13LA38 & 13LA30.....	261
The Upper Mississippi Basin.....	261
References Cited.....	266
Appendix A	
Request for Proposal, SMS Proposal, Correspondence.	290
Appendix B	
Soil Descriptions.....	323
Appendix C	
Ceramic Definitions.....	332
Appendix D	
Lithic Attributes and Definitions.....	339
Appendix E	
Archaeobotany.....	345
Appendix F	
Human Remains.....	355

Figures	Page
Figure 1.1. The location of Sand Run on the Prairie Penninsula & in the Sand Run locality.....	13
Figure 1.2. Detail of Sand Run Slough site.....	15
Figure 2.1. Sand Run West (13LA38).....	32
Figure 2.2. Sand Run Slough Test Unit Profiles.....	33
Figure 2.3. Block B Stratigraphy.....	34
Figure 2.4. Block C Stratigraphy.....	35
Figure 2.5. Sand Run West N-S Section.....	36
Figure 2.6. Block A. Stratigraphy 13LA38.....	37
Figure 2.7. Block A Excavation 13LA38.....	38
Figure 2.8. 13LA38 Block A Features, Middle Woodland Component.....	39
Figure 2.9. 13LA38 Stratum II Features.....	40
Figure 2.10. 13LA38 Block B Features, Middle Woodland Component.....	41
Figure 2.11. 13LA38 Stratum IIIa Features & Artifacts.....	42
Figure 2.12. 13LA38 Block B Features, Late Archaic Stratum IIIa Component.....	43
Figure 2.13. 13LA38 Stratum IIIb Features & Artifacts.....	44
Figure 2.14. 13LA38 Block B Features, Late Archaic Stratum IIIb Component.....	45
Figure 2.15. 13LA38 Stratum IIIc Artifacts and Features...	46
Figure 2.16. 13LA38 Block B Features, Late Archaic Stratum IIIc Component.....	47
Figure 2.17. 13LA38 Block C Excavations.....	48
Figure 2.18. 13LA38 Block C Features.....	49
Figure 2.19. 13LA38 Test Unit Features.....	50
Figure 3.1. Detail of Black Sand Incised sherds.....	75

Figure 3.2.	Details of the late Late Woodland cord roughened sherds from 13LA38.....	75
Figure 3.3.	Marion Thick sherds from 13LA38.....	76
Figure 3.4.	Liverpool Cordmarked from 13LA30 and 13LA38..	77
Figure 3.5.	Black Sand Incised sherds from 13LA30 and 13LA38.....	77
Figure 3.6.	Sister Creeks Punctated from 13LA30 and 13LA38.....	78
Figure 3.7.	Morton/Fettie Incised from 13LA30 and 13LA38.....	78
Figure 3.8.	Stamped Havana ware from 13LA38.....	79
Figure 3.9.	Havana ware from 13LA30 and 13LA38.....	79
Figure 3.10.	Havana ware from 13LA30 and 13LA38.....	80
Figure 3.11.	Sherds from 13LA38.....	80
Figure 3.12.	Weaver ware from 13LA30 and 13LA38.....	81
Figure 3.13.	Linn ware from 13LA30 and 13LA38.....	81
Figure 3.14.	Late Late Woodland corded ceramics from 13LA30 and 13LA38.....	82
Figure 3.15.	Late Late Woodland plain rims from 13LA30....	82
Figure 3.16.	Miscellaneous ceramic items from 13LA38.....	83
Figure 4.1.	Stratum I chipped stone tools.....	157
Figure 4.2.	Blades from 13LA38 excavations.....	157
Figure 4.3.	Three gun flints from Stratum I, dihedral blade core from Stratum II, disk blade from Stratum II.....	158
Figure 4.4.	Chipped Stone bifaces from Stratum I.....	158
Figure 4.5.	Projectile points from Stratum I.....	159
Figure 4.6.	Chipped stone biaces.....	159
Figure 4.7.	Bifacial digging tools.....	160
Figure 4.8.	Chipped stone drills from 13LA38.....	160
Figure 4.9.	Stratum II projectile points.....	161

Figure 4.10.	Stratum III projectile points.....	161
Figure 5.1.	Items from the 13LA38 excavation blocks.....	196
Figure 5.2.	Limonite cobbles from the 13LA38 excavations.....	196
Figure 5.3.	Hammerstones from the 13LA38 excavation.....	197
Figure 5.4.	Grinding stones from the 13LA38 excavations..	197
Figure 5.5.	Tools from the 13LA38 excavations.....	198
Figure 5.6.	Large metate on igneous cobble with heavily pitted and smoothed surface and edges.....	199
Figure 8.1.	Early Woodland Period.....	258
Figure 8.2.	Middle Woodland Period.....	259
Figure 8.3.	Woodland Age Sites.....	260
 <u>Tables</u>		
Table 2.1	Estimated Sedimentation Rates at Sand Run....	23
Table 2.2	Typed Ceramics Block A.....	28
Table 2.3	Typed Ceramics Block B & TU 6,7.....	28
Table 2.4	Typed Ceramics Block C & TU 5.....	29
Table 2.5	13LA38 Feature Data.....	30
Table 3.1	All Excavated & Surface Pottery.....	84
Table 3.2	Body Sherds in Excavation Levels.....	85
Table 3.3	Liverpool Cordmarked Attributes.....	86
Table 3.4	Black Sand Incised Attributes.....	87
Table 3.5	Sister Creeks and Morton Incised Attributes..	88
Table 3.6	Attributes of Havana Ware.....	89-90
Table 3.7	Composition of Middle Woodland Ceramics Assemblages.....	91
Table 3.8	Attributes of Hopewell, Baehr & Baehr/ Pike Ceramics.....	92
Table 3.9	Attributes of Weaver Ware.....	93

Table 3.10	Attributes of Linn Ware.....	94
Table 3.11	Attributes of Minature Vessels.....	95
Table 3.12	Composition of Early Late Woodland Ceramics Assemblages.....	96
Table 3.13	Attributes of Late Late Woodland Wares.....	97
Table 3.14	Trans-Iowa Comparison of Cord Decorated Types.....	98- 99
Table 3.15	Ceramic Ware Stratigraphy.....	100
Table 4.1	Typological, Technological and morphological characteristics of the lithic debitage from Stratum I. 13LA38.....	162
Table 4.2	Lithic debitage technological characteristics and types. Stratum II.....	163
Table 4.3	Lithic debitage characteristics and types from Stratum II features.....	164
Table 4.4	Lithic debitage technological characteristics and types. Stratum III.....	165
Table 4.5	Lithic debitage technological characteristics and types. Stratum III features.....	166
Table 4.6	Typological, technological and morphological characteristics of the lithic debitage from three strata.....	167
Table 4.7	Lithic debitage chert types.....	168
Table 4.8	Core types, weights and block distributions from 13LA38.....	169
Table 4.9	Total number and percentages of the technological and morphological characteristics of unhafted flakes tools.....	170
Table 4.10	Chert types and unhafted flake tool types from Stratum I, 13LA38.....	171
Table 4.11	Technological characteristics associated with unhafted flake tools recovered from Stratum II. 13LA38.....	172
Table 4.12	Tool uses, retouch, wear, and chert types of the unhafted flake tools from Stratum II. 13LA38.....	173

Table 4.13	Technological characteristics associated with unhafted flake tools from Stratum III. 13LA38.....	174
Table 4.14	Tool uses, retouch, wear, and chert types of the unhafted flake tools from Stratum II. 13LA38.....	175
Table 4.15	Total number and percentages of the technological and morphological characteristics of unhafted flakes tools....	176
Table 4.16	Dimensions of unhafted flake tools from Stratum I, 13LA38.....	177
Table 4.17	Dimensions of unhafted flake tools from Stratum II. 13LA38.....	178
Table 4.18	Dimensions of unhafted flake tools from Stratum III.....	179
Table 4.19	Hafted flake tool chert type, blank types and dimensions. Stratum I, 13LA38.....	180
Table 4.20	Technological characteristics associated with hafted flake tools from Stratum I, 13LA38.....	181
Table 4.21	Attributes defining the blade industry at 13LA38.....	182
Table 4.22	Dimensions, chert types uses for blades, 13LA38.....	183
Table 4.23	Chipped stone tools attributes, not including projectile points or retouched flakes. Stratum I.....	184
Table 4.24	Projectile point characteristics from 13LA38.....	185
Table 4.25	Projectile point attributes and chert types.	186
Table 4.26	Dimensions of projectile points from Stratum I.....	187
Table 4.27	Block B Projectile Points.....	154
Table 5.1	13LA38 Block A, Cobbles & Fire-Cracked Rocks.	200
Table 5.2	13LA38 Block B & Test Units 6, 7.....	201
Table 5.3	13LA38 Block C & Test Unit 5, Cobbles and Fire-Cracked Rocks.....	202



Table 5.4	Metal and Ground Stone, 13LA38.....	190
Table 6.1	Soil Samples Processed by Flotation, 13LA38..	221
Table 6.2	Counts (ct) and Weights (wt-gm) for Major Classes of Archaeobotanical Materials.....	222
Table 6.3	Wood Charcoal Identifications.....	223
Table 6.4	Carbonized Seed Number Estimates (SNE) per Taxon.....	224
Table 6.5	Measurements of Chenopodium Seeds.....	213
Table 6.6	Selected Seed Species from Samples Not Processed for the Archaeobotany Study.....	225
Table 7.1	13LA38, Tabulation of all Bone Remains from General Excavations.....	231
Table 7.2	Identified Faunal Remains, 13LA38 General Excavations.....	232
Table 7.3	Faunal Remains from Flotation Samples, 13LA38 Blocks A and C.....	234
Table 7.4	Faunal Remains from Flotation Samples, 13LA38 Block B.....	233
Table 7.5	Fish Remains from Flotation Samples, 13LA38..	235
Table 7.6	Seasons of Death in Sand Run Fish Vertebrae..	230

## ABSTRACT

*Site supported by TALS*

This report covers intensive archaeological investigations at the Sand Run West site (13LA38), Louisa County, Iowa. The work was performed by the Center for Archaeological Research, Southwest Missouri State University, for the Rock Island District Corps of Engineers under terms of contract number DACW25-86-C-0025. The purpose of the excavations was to recover significant cultural remains from a stratified Woodland and Late Archaic deposit being eroded by high water levels and recreational traffic on Sand Run Slough.

Research at Sand Run West followed four avenues of investigation. Geomorphic and pedogenic analysis of the site deposits resulted in the separation of cultural components based on their association with conspicuous soil horizons. Sediments stemming from alluvial fan and terrace (overbank) sources were identified and differentiated. Natural depositional processes and radiocarbon dates were used to develop a model of site formation which recognized cultural components as aggregated middens, not single occupations.

Research focused on the cultural inventory from the site. A ceramic sequence spanning all of the Woodland periods in the Midwest was described by attribute analysis and tied to existing ceramic sequences in Iowa and Illinois. The Mississippi River and lower reaches of major river valleys in southeastern Iowa were distinguished as a region, the Three Rivers region. The culture history of this region was shown to parallel the sequence in the Central Illinois River valley. Chipped stone tool remains reveal similar relationships. Also found in the chipped stone tool analysis were significant differences between Late Woodland and Middle Woodland/Late Archaic industries. The Late Woodland assemblage is characterized by small tools and cores and more softhammer percussion, in contrast to the larger flakes and cores and hardhammer percussion of the earlier periods. Analysis of the fire-cracked rock and cobble assemblage revealed the presence of several types of cobble tools, most of which had been recycled as heating stones. The assemblages of Woodland and Late Archaic components also included hematite and galena.

Investigation of the subsistence and resource utilization at Sand Run West revealed that the site was used as a base camp throughout most of the occupations. Bone preservation was poor and inconsistent, offering only the broad conclusion that subsistence patterns focused on woodland mammals and riparian resources. The botanical assemblage included the presence of the native seed horticultural complex in the Middle Woodland components and probably in the Late Archaic components. Wild rice also was an important resource used by Late Archaic peoples.

The geomorphic and pedogenic contexts of the cultural deposits were employed to establish a model for floodplain contexts of archaeological materials in the Mississippi River valley. Results of the investigation differentiated between preservation potentials in alluvium and colluvium and identified soil horizons that might be used as stratigraphic markers in future excavations.

Interpretation regarding the cultural history of eastern Iowa and the Upper Mississippi basin are presented as they relate to the evidence from Sand Run. The Late Archaic and Woodland cultural sequences of the Mississippi River valley and interior Iowa are compared and contrasted to point out similarities in cultural evolution as well as time lags in technical developments.

The final portion of the report presents recommendations for future work in the Upper Mississippi basin. Suggestions are made in the areas of archaeobotany, lithic and ceramic analyses, how to deal with relative preservation of faunal remains, landform analysis, procedures for archaeological investigations in the floodplain, and how to approach the problem of mitigating site impacts.

David W. Benn  
principal investigator

I  
INTRODUCTION TO THE INVESTIGATIONS  
AT SAND RUN SLOUGH

This is a report of intensive archaeological investigations of the Sand Run West site (13LA38), Louisa County, Iowa (Figure 1.1). This work was performed by the Center for Archaeological Research, Southwest Missouri State University under contract with the Rock Island District, Corps of Engineers (contract no. DACW-25-86-C-0025). Investigations began with site testing on May 21-25, 1986. Block excavations were accomplished from July 26 to August 23, 1986. David W. Benn functioned as principal investigator by directing all fieldwork and doing the analysis of material remains.

The Sand Run project was done pursuant to the intent of federal legislation and guidelines which protect cultural resources. The federal actions that apply to this project include the National Environmental Policy Act, Executive Order 11593 (protection and enhancement of cultural environment), Section 106 of the National Historic Preservation Act (PL 89-665) as amended, guidelines by the Advisory Council on Historic Preservation (36 CFR 66), and procedures for the Protection of Historic and Cultural Properties (36 CFR 800 amended).

The present volume is divided into nine chapters. The Introduction contains descriptions of the project location, research objectives and the natural setting. The second chapter contains the field investigations and an analysis of the geomorphology and cultural stratigraphy. The ceramic assemblage is analyzed in the next chapter, followed by descriptive analyses of chipped stone in Chapter IV, cobble tools in Chapter V, archaeobotanical remains in Chapter VI, and faunal remains in Chapter VII. A cultural overview and interpretation is presented in Chapter VIII, and recommendations for future work in the Mississippi valley are discussed in Chapter IX. Appendices describe the Scope-of-Work (A), soil profiles (B), pottery wares (C), lithic typology (D), archaeobotany (E) and human remains (F).

#### Site Location

Sand Run Slough is the southern outlet of Lake Odessa, a backwater of the Mississippi River in eastern Louisa County, Iowa (Figure 1.1). The slough runs at the base of the west (right) bluffline of the Mississippi valley. The Iowa River confluence is three miles east of the site.

The site now designated as Sand Run West (13LA38) is one of many prehistoric deposits along Sand Run Slough south of Lake Odessa (Figure 1.1). These sites have been visited by local collectors and professional archaeologists for more than two decades. The official site records at the Office of the State Archaeologist, Iowa City, reflect several changes in site numbers and site locations for the Sand Run Slough locality. Dale Henning appears to have recorded the first site, 13LA3, on Sand Run during his 1958 reconnaissance survey of Louisa County (Till 1977:192). The records do not pinpoint 13LA3 precisely, but the site has since become established in the records as the large alluvial fan at Sand Run, long developed with a boat access, beach and summer cottages. The 1977 Great River Road survey (Hotopp ed. 1977:Map 5) shows two site numbers (13LA3, 13LA91) on this fan. The site on the shoreline north of the fan is numbered 13LA100 and called the Ray Green A site (Till 1977:224). It was recorded in 1976 by J.M. Higgins. 13LA100 is described as "just below" the Sand Run access road, which today would place it below the red cabin on the access road or not more than 61m (200ft) north of the 13LA3 fan. The red cabin is on a bench that extends to the shoreline. North of this bench along the shoreline for a distance of 185m (600ft) north of the fan are segments of inset terrace and small fans that comprise 13LA38 (Figure 1.2). Site 13LA38 was recorded by Zieglowsky in 1980 as the Guenther site and in 1981 by Duane Miller as Sand Run West. Across the slough the Sand Run Access site (13LA30) was recorded in 1980 by Tiffany. Site 13LA30 extends at least 215m (600ft) north of the point across from the Sand Run access.

Sand Run West (13LA38) has been visited by professional archaeologists from the Office of the State Archaeologist (OSA) since 1980, and surface collections numbering more than a thousand pottery sherds, lithics and bones have been accessioned at the OSA (see Appendix C in Corps of Engineers 1985). Local collectors also have obtained quantities of material from the shoreline. In July, 1985 the Corps of Engineers (COE) was notified that human remains might be eroding from the site. Charles Smith and Kenneth Barr (COE) visited and later conducted an investigation of the river bank stratigraphy and made collections from 13LA38 and 13LA30 (Corps of Engineers 1985). They identified a full range of Woodland ceramic types and observed that at least two buried soil horizons (i.e. Archaic and Woodland aged) were present. No human remains were present.

Because sites 13LA30/38 were eroding into a navigable channel under the jurisdiction of the COE, part 800.2c of 36CFR 800 ("area of potential impacts") applied to the site impacts. Procedures were implemented to identify and evaluate the extent of site impacts (part 800.4b,c), and a finding of "adverse impacts" (part 800.5e) was made. Charles Smith recommended that the Sand Run sites (13LA30, -38) be declared eligible for inclusion on the National Register of Historic Places. Kay Simpson, Iowa SHPO archaeologist, agreed that the sites were eligible for listing on the National Register. The sites were

approved by the Keeper of the NRHP on 15 November 1985, and the Advisory Council approved the plan for data recovery proposed by the COE.

### Research Problems

The project research plan is described below as initially proposed (see the Data Recovery Proposal, Appendix A). The plan also is evaluated as it was carried out in the field and laboratory.

The COE requested that excavations be conducted on 13LA38 and 13LA30. The sites were believed to contain a stratified cultural sequence that could elucidate the culture history in the Mississippi River floodplain. The work on 13LA30 was expected to be relegated to testing, since this cultural deposit is much larger and less impacted than 13LA38. The spring and summer field season of 1986 saw continuous high water levels due to an exceptionally large amount of rain during June and July in eastern Iowa. The high water level of Sand Run Slough never dropped below near bankful at 13LA30, and the site was not thoroughly tested. Site 13LA38 is a meter higher in elevation. Excavation of the entire depth of the cultural deposit was possible on 13LA38, although water entered the bottoms of the excavation blocks. High water also abrogated plans to visit nearby floodplain sites.

Seasonal high water became another limitation added to the list of three constraints foreseen in the original research plan (Appendix A, "Assumptions"). The first of the anticipated constraints was the recognition that excavations had to focus on a narrow, linear impact zone along the slough bank and could not presume to sample all of the variability within the sites. Also, the excavations had to dig deep to reach the Archaic components, so digging methods had to be economical. Rainy days and high water during the fieldwork exacerbated constraints in the excavation plan.

The second project constraint was that geoarchaeologic interpretations from a single locus (13LA30/38) could not be applied cavalierly on a regional scale (cf. Gladfelter 1985:42). At best, it was hoped that the context of 13LA30/38 could be matched with floodplain models from the Midwest (e.g. Church n.d.; Gladfelter 1981). This constraint became more significant when high water and dense forest cover at the site locality prevented wide-ranging examination of soil profiles and on-site drilling.

The third project constraint involved focusing material analysis and interpretations on a limited range of research subjects. The concern here was that finite project funds would be dissipated ineffectively if research goals were too divergent. This became a real issue when the excavation yielded large

quantities of remains from several discrete components in three different soils. Much of the labor during analysis involved sorting, tabulating and regrouping categories of information for lucid presentation in this report.

Given these constraints, four topics of research were proposed for the work at Sand Run Slough (Appendix A).

#### 1) Geomorphic/Pedogenic Contexts:

The proposal addressed the question of whether 13LA38 and 13LA30 were a single site cut by a recent chute, now Sand Run Slough, or have always been two sites on opposite banks of an abandoned channel. If two sites existed, then their depositional histories could be different (topics 1a,b). The footslope position of 13LA38 would make it a vertical accretion deposit which might contain older material than 13LA30, a horizontal accretion deposit of the backchannel system in the floodplain (cf. Church n.d.:48-49). Another topic (1c) involved the application of geomorphic/pedogenic analyses in the digging methods. It was proposed that attention paid to the minor fluctuations of natural stratigraphy in the excavation blocks would result in clearer definition of cultural components, particularly mixed ones, thus an improved perspective of cultural assemblages and culture change.

Present and previous investigations show that Sand Run Slough is a paleo-channel, therefore there are two sites. The stratigraphic profile at 13LA30 has the same soil sequence and same artifact content as 13LA38, so the two sites are not significantly different as accretionary deposits. The three soils on the alluvial fan and terrace at 13LA38 correspond with the three major components: Late Woodland, Early/Middle Woodland and Late Archaic periods. The co-occurrence of episodes of sedimentation and soil formation, and certain culture periods is not presumed to be a causal relationship. Rather, because certain cultural components were deposited during periods of soil formation, their assemblages became mixed due to natural soil formation processes. If the correspondence between certain components and certain soils or sediments can be shown to have a pan-regional distribution, then we have a pedogenic/geomorphic explanation for the archaeological visibility of some cultures (cf. Bettis and Thompson 1981).

#### 2) Cultural Inventory:

Topic 2 recognized that materials from the Sand Run sites could be related to existing typed assemblages in the Midwest. Emphasis in the research focused on identifying types and assemblages from Sand Run and fitting them into known regional patterns. This, basically, was an exercise of filling "gaps" in knowledge about prehistoric southeastern Iowa. As pieces of

information fitted together, specific research problems were considered.

Research problems (2a) concerned the relationships and distributions of ceramic types from Sand Run. A full range of Woodland potteries came from the site. The Marion component is minor, but the Black Sand tradition is found to be well represented in eastern Iowa (Spring Hollow Incised was excluded from the typology). The inception of the Havana tradition also is evidenced by the presence of Morton and Fettle ceramic types. This raises the possibility that the Black Sand and Havana traditions were contemporaries. The Sand Run sites are on the periphery of the distribution of Linn ware. Weaver ware dominates the assemblage. Late Woodland potteries are organized into regional series of three time periods, but nomenclature is not applied to every ceramic type and ware.

Research on chipped stone remains (2b,c) concentrated on identifying diagnostic types among projectile points and informal (flake) tools with the overall goal of specifying the composition of assemblages. Signs of use-wear were recognized to relate tool functions to other parts of the Sand Run assemblage (e.g. faunal and floral remains, cobble tools, features). Projectile points were recovered in disappointingly small numbers--too few for elaboration of Iowa typologies (e.g. Morrow 1984). Informal tools and lithic debitage are grouped chronologically and culturally into distinct industries that employed hard or soft hammer percussion techniques. The chipped stone industries of the Late Archaic and Middle Woodland periods were found to be more similar than the small tool industry of the Late Woodland period.

The regional relationships and chronological sequence of Sand Run artifact types (2d) indicates that there was a cultural pattern specific to a portion of the Upper Mississippi River valley for (at least) the Woodland periods. The Three Rivers region is the term coined to describe this zone of similarities in content and culture tradition. The Three Rivers region encompasses the Mississippi valley from above the Rock River (e.g. up to Clinton, Iowa) south to the mouth of the Des Moines River. The region includes the lower reaches of tributaries to the Mississippi and probably extends several tens of miles up the Skunk and Iowa/Cedar rivers. In short this is a "large valley" region which is interfaced with the small interior valleys and uplands.

### 3) Resources, Subsistence & Setting:

The patterns of subsistence and settlement at Sand Run are areas of research because bones occur with abundant lithics and ceramics, a situation not always common in the floodplain. An intact Sand Run assemblage is available from comparison to other recent published sites. Among specific research issues are the



sources of raw materials (3a), which is a reflection of regional socio-economic patterning. Another problem is the investigation of the species/habitat composition represented at Sand Run (3b), and how the composition fits the patterns of other Woodland and Late Archaic communities in the Midwest. Also part of the investigation is the comparison between Sand Run components to see if changes took place in technology, subsistence and settlement patterns through time (3c).

In terms of subsistence analyses, a critical deficiency that appeared in the Sand Run excavation was inconsistent and generally poor bone preservation. No mussel shell was preserved. There was enough bone from the Late Archaic component to estimate the species composition, but comparisons with the bone-poor Middle Woodland component and boneless Late Woodland component were impossible. Archaeobotanical remains were adequate to reveal the presence of simple horticulture during the Late Archaic and Middle Woodland periods. Lithic tool types showed a wide range of domestic and technical activities were pursued at the site, indicating that Sand Run functioned as a base camp for extended periods of occupation.

The contrast between Late Woodland and Late Archaic components was especially distinct in the lithic assemblages. The Late Archaic pattern of hard hammer percussion that produced coarse flakes differed from the Woodland pattern of soft hammer percussion and finer flakes. The Late Archaic cobble tool assemblage also was larger and more diverse. These tools generally reflect growing regional interaction through time.

#### 4) Cultural Resource Management:

The proposed research at Sand Run was directed toward analyzing the horizontal and vertical extent of the cultural deposit to determine if it conformed to the structure of the geomorphological landscape, i.e. linear relative to the channel and horizontal accretionary deposits. Investigation of this simple notion was abrogated by high water which prevented work on 13LA30. However, excavation of 13LA38 revealed that cultural components could be correlated with soils and sediments in the Mississippi floodplain (see topic 1, third paragraph). If periods of sedimentation and pedogenesis can be correlated on a regional scale, then site associations might be predicted from analysis of floodplain sediments (cf. Bettis and Benn 1984).

#### Previous Investigations

Louisa County contains the Iowa, Cedar and Mississippi Rivers. The confluence of these streams and Muscatine Slough in the Mississippi River floodplain certainly were attractive to many aboriginal peoples. And so, archaeologists and private

collectors have been attracted to the rich archaeological resources of Louisa County. Records of these archaeological activities have accumulated for 100 years, but the vast majority of records are initial impressions of prehistoric evidence (e.g. Rev. Gass' terse descriptions of mound digging, +250 site records in the OSA, reconnaissance surveys since 1950, brief field reports in the Iowa Archeological Society Newsletter). These references contain gems of insight and pieces of long-lost evidence, but their information is not presented in a systematic, detailed manner useful for comparative research. This section will present a review of the major sources and authors of archaeological investigations with the intention of identifying references relevant to the Sand Run project.

The earliest recorded investigations were strictly antiquarian in interest and approach (Willey and Sabloff 1974). Members of the Davenport Academy of Natural Science and local people dug in mounds in Louisa County (e.g. Farquarharson 1876; Gass 1881; Blumer 1882; Starr 1895). They were pursuing the "Mound Builders," a myth about ancient civilized people who had been displaced by modern Indians. What early antiquarians encountered along the Mississippi River bluffs in Louisa County were numerous mound groups, big conical mounds with log chambered tombs, animal effigy pipes, copper and obsidian (Starr 1895; McKusick 1970) and an occasional earthwork like the enclosure at McKinney (Newhall 1841). Much of this evidence is now gone but not forgotten thanks to the publications of this period.

More recording of mound groups and village sites occurred as a result of the travels of Ellison Orr and Charles R. Keyes during the first four decades of the twentieth century (see Orr 1935). The Keyes/Orr records mention 18 sites in Louisa County (Tiffany 1981) but represent less intense survey and recording of sites than in some other parts of the state.

Survey and recording of sites coupled with excavations commenced in 1958 with a project by R. J. Ruppe' of the University of Iowa. Ruppe' and his student, Adrian Anderson, recorded many of the most significant sites (e.g. Old Peter Haas Farm 13LA10, Smith Village 13LA3, Smith Mounds 13LA15, Gast Farm 13LA12) on the bluffs north of the Iowa River, and they initiated contacts with local collectors which have lasted for years and resulted in many more recorded sites (cf. Till 1977). Much of Ruppe's work has not been published (see Iowa Archaeological Society Newsletter 1958:1; Anderson 1958, 1971a; Scholtz 1958).

The decade of the 1970s witnessed renewed excavation activities. The McKinney Oneota site was tested (Slattery et al. 1975) and subsequently excavated by Iowa Archaeological Society Fieldschools (see Tiffany 1979, 1982). The multi-component Poison Ivy site (13LA84) at the mouth of the Iowa River also was tested by the University of Iowa (Alex 1978) as was the nearby Helen Smith site (13LA71). The McKinney and Poison Ivy site investigations were precipitated by an interest in the variant of

Oneota culture that occurred in southeastern Iowa. Government review and compliance archaeology also began during the mid-1970s. Weichman (1974) conducted a wide ranging survey of the Muscatine Island area prior to the construction of levees. He recorded occupation sites on the Sand Mound, on levees in the floodplain and on the talus slope of the bluff and relocated mounds on the bluff crest. His survey was followed by the Tandarich (1976) and Luther College surveys (Benn and McKay 1977; Benn and Bettis 1978) of the Sand Mound, now the location of the Iowa-Illinois Gas and Electric Company power plant. Sites on the Sand Mound were found to be temporary camps containing mostly lithic debitage. These sites contrast with many of the village sites with pottery and lithic tools located by Weichman and the University of Iowa crews along the bluffline.

The most comprehensive catalogue of Louisa County sites was produced by the initial Great River Road survey (Till 1977). Site records, collections and locations were compiled for the first time. However, this work lacked analysis of the materials and an overview of cultural manifestations. The survey was followed by phase II testing of sites in the road alignment (Perry 1982) and by intensive excavation of six sites determined eligible for the National Register (Fokken and Finn 1984). The latter was the Michaels Creek investigation in which blufftop and talus slope occupation sites were excavated. Although few of the sites were stratified, the Michaels Creek report contains the most complete overview of culture periods in the region and a complete analysis of lithic and ceramic remains from the excavations. Site 13LA56 at Michaels Creek is similar to 13LA38 in geomorphic structure and culture content.

Another thorough contract report is the phase II testing of 17 sites along the Great River Road west of Lake Odessa (Fokken and Marcucci 1984). None of the sites was judged to be significant or impacted by the road, including mound groups and historic cabins on the blufftop above Sand Run. The most recent investigation in the Sand Run vicinity was testing by the University of Iowa at the Smith site (Billeck 1986b). Billeck analyzed the material from Ruppe's 1958 work and his own, part of which is a substantial assemblage of Early Woodland Marion-like pottery. These ceramics have decorations of large, round impressions. Recent archaeological survey of Kilpeck's Landing and Ferry Landing on the Mississippi River yielded no cultural remains (Johnson et al. 1985).

Other literature representing archaeological work outside Louisa County is relevant to the Sand Run investigation. Most of these sources are referenced later in this report. Across the Mississippi River in Illinois there have been test excavations at the Sloan site (Benchley et al. 1979), Albany Mounds (Benchley et al. 1977), Deere Creek (Markman and Kreisa (1986), 11R1337 at Moline (Van Dyke et al. 1980), and Middle Woodland sites in Henderson County (Gregg 1974; Lippincott and Herold 1965; Bailey 1977; Riggle 1981). Benchley et al. (1981) also present an

overview of settlement patterns in the Mississippi River valley. Farther afield the investigations in the American Bottom (Bareis and Porter eds. 1984), the Upper Mississippi River valley (McGimsey and Conner 1985; Morgan et al. 1986), the Lower Illinois River valley (Stafford and Sant ed. 1985; Farnsworth and Asch 1986), and in Wisconsin (Stoltman 1979, 1986; Overstreet 1984b) are significant for comparison to the Sand Run materials. In Iowa the major projects with materials that can be compared with Sand Run include Logan's dissertation (1976), the F-518 road project (Lensink ed. 1986), the FTD site (Benn 1978), the Pleasant Creek project (Benn and Thompson 1977) and the Saylorville Lake project (Benn and Rogers 1985). Other review and compliance projects in southeastern Iowa are enumerated by Jacobs and Perry (in Lensink ed. 1986:19-23).

### Natural Setting

The Sand Run site is situated at the base of the Mississippi River bluff and faces east with the expanse of the floodplain before it. The bluff is 30m (100ft) high and affords the site excellent protection from foul weather. This setting has not changed significantly since the site was first occupied (ca. 4500 B.P.). By analogy with the Illinois River Valley (Asch et al. 1972; Styles 1981), it is presumed that the native vegetation around Sand Run also has not changed significantly during the Late Holocene period (ca. 10,000 years).

The present climate in the Louisa County area (Thorntwaite 1941; Fokken and Marcucci 1984:2-8) is moist subhumid continental, meaning there are hot, humid summers and relatively mild winters that have subzero cold spells. The average frost-free season is 159 days, and the annual precipitation average is 44 inches (March, June and July are the months with highest precipitation). The spring and early summer months also are times of the year when the Mississippi River floods its backchannels.

Reconstructions of past climatic episodes (Wright 1968; Webb and Bryson 1972; Wendland 1978) outline a series of environmental changes that happened in the Midwest. It has not been demonstrated that any of these changes profoundly affected floodplain environments like that at Sand Run, although the fluvial system was modified. Any change in the fluvial system certainly affected the sedimentary record at Sand Run. Past climatic episodes are easiest to see in the dominant vegetation. During the late glacial period (prior to ca. 13,500 B.P.) a mixed coniferous-deciduous forest of birch, spruce and larch covered southeastern Iowa. During the early Holocene the coniferous forest was succeeded by a deciduous forest of oak and elm (ca. 9000 B.P.). The Midwest continued to become drier between ca. 9000 and 7000 B.P., the Hypsithermal interval, causing prairie to expand into eastern Iowa. By ca. 6200 B.P. the prairie covered all but the protected slopes and mesic floodplains in eastern

Iowa. Since ca. 6000 B.P. the climate has returned to conditions like the present day with minor oscillations of wet/cool and warm/dry episodes.

The native biota of Louisa County (Guldner 1960; Christiansen 1981; Menzel 1981; Bowles 1975; see Fokken and Marcucci 1984:2-10 for a tabular summary of biota) included the habitats of prairie, forest edge, sideslope and bottomland forest, floodplain meadows and marshes, and stream banks. All of these habitats occurred within a one mile radius of the Sand Run site. The upland prairie contained mid- to tall-grass species and a wide range of forbs and herbs (see Schimek 1911). Elk, prairie chicken and bison (later) were important creatures on the prairie. Burr oak, crab, red cedar and other zeric adapted trees interfaced with the prairie, creating an edge habitat with a very high biomass of animals (e.g. box turtle, bobwhite, badger, coyote, deer) and edible plants. This edge habitat probably occurred on the blufftop above Sand Run. Along the bluff edge and on valley sideslopes the vegetation was oak/hickory forest, which was a zone of nut resources and animals like deer, black bear, the wolf, raccoon, opossum, squirrels, bobcat, turkey and passenger pigeon. The floodplain forest had a closed canopy of maples, black walnut, hackberry, sycamore, red elm, green ash and Kentucky coffee tree and animals such as woodland turtles, lizards, turkey, opossum, porcupine, squirrels, ermine and skunk. Interspersed on the floodplain were sedge meadow (seasonally flooded), marshland (standing water) and stream bank communities. In these communities were canary-reed grasses, cattail, bulrushes, amaranths, goosefoots, willow trees, lotus, duck potato and marshelder as well as salamanders, frogs, turtles, snakes, migratory waterfowl, river otter, mink, muskrat and beaver. The aquatic community contained at least 80 species of fish, several types of turtles, more than four dozen species of freshwater mussels and several kinds of snakes.

The surficial bedrock of the region is important for the types of chert that were available for the manufacture chipped stone tools. While maps of the bedrock are widely available from the geological surveys of each state, the identification of cherty stones and their primary sources is in a preliminary stage. An overview of the region's bedrock and chert resources is depicted in Figure 1.3.

Rock outcrops are rare in Louisa County, most being along tributaries of the Iowa River and at the mouth of the Iowa River valley in southern Louisa County (Kirkpatrick 1967). Cherts in glacial tills would be the only local sources within 5-10mi of Sand Run. West and south in Iowa and across the river in west-central Illinois the types of cherts that were quarried came from formations of the Mississippian age. These cherts are typified by inclusions of crinoids and other fossils and are highly variable in color and morphology. The attributes, sources and distributions of all Mississippian cherts have not been

defined, but major categories that are recognized include the following (see Moore 1981; Morrow 1984:99).

Burlington: white to gray to tan in color with light banding; varying amounts of crinoid and other fossils; fine texture; heating causes pink hues and luster; outcrops in the Burlington formation west, south and east (across the river) from Sand Run. (White Crescent chert from the St. Louis, Missouri vicinity is fossil-free.)

Wassonville: cream to moderate gray in color with numerous fossil bits or patches and speckles of color; fine-medium texture; heating produces pink hues and luster; outcrops in the Hampton formation west and northwest of Sand Run.

Keokuk (Montrose in Illinois): mostly gray to cream and tan in color; finely fossiliferous; fine-medium texture; heating produces luster and occasionally pink hues; outcrops in the Keokuk formation in the Des Moines valley south of Sand Run.

Warsaw: the chalcedonic form is white to blue-white or gray and pink and occurs in rounded nodules; coarse-fine texture and often somewhat translucent; heat treating causes slight luster; outcrops in the Warsaw formation more than 30mi west of Sand Run; the tabular and banded forms occur in flat plates (.5-5cm thick) of gray-banded chert with a chalky rind of cream or tan; fine-medium texture; heating gives a reddish hue, especially to the cortex; the tabular variety outcrops ca. 30mi west of Sand Run; the banded variety seems to occur sporadically throughout southeast Iowa and western Illinois.

La Moines: gray to dark reddish gray color with white fossil inclusions; coarse texture; heating causes a smoother texture; outcrops in the St. Louis formation in the La Moines River basin, west-central Illinois.

Cobden: medium to dark gray and olive gray or blue gray colors with concentric banding; fine texture, satiny luster; outcrops in the St. Louis formation in Union County, southern Illinois.

One Pennsylvanian age rock unit yields workable chert that has been identified in archaeological contexts in Iowa.

Moline: blue, dark blue and blue gray bands with black and white speckling and streaking; medium-fine texture; heat treating gives slight luster and perhaps darker colors; outcrops in the Spoon formation in the vicinity of the Quad-Cities, Iowa and Illinois (Birmingham 1985).

While conducting the fieldwork at Sand Run the writer talked with local collectors who recognized chert outcrops not yet reported in the archaeological literature. None of these were

close to Sand Run, but it is clear that some bedrock outcrops in the Mississippi River trench are not yet recognized. For instance, the distribution of Warsaw Tabular and Banded cherts probably extends to the Mississippi Valley from interior Iowa and perhaps into western Illinois.

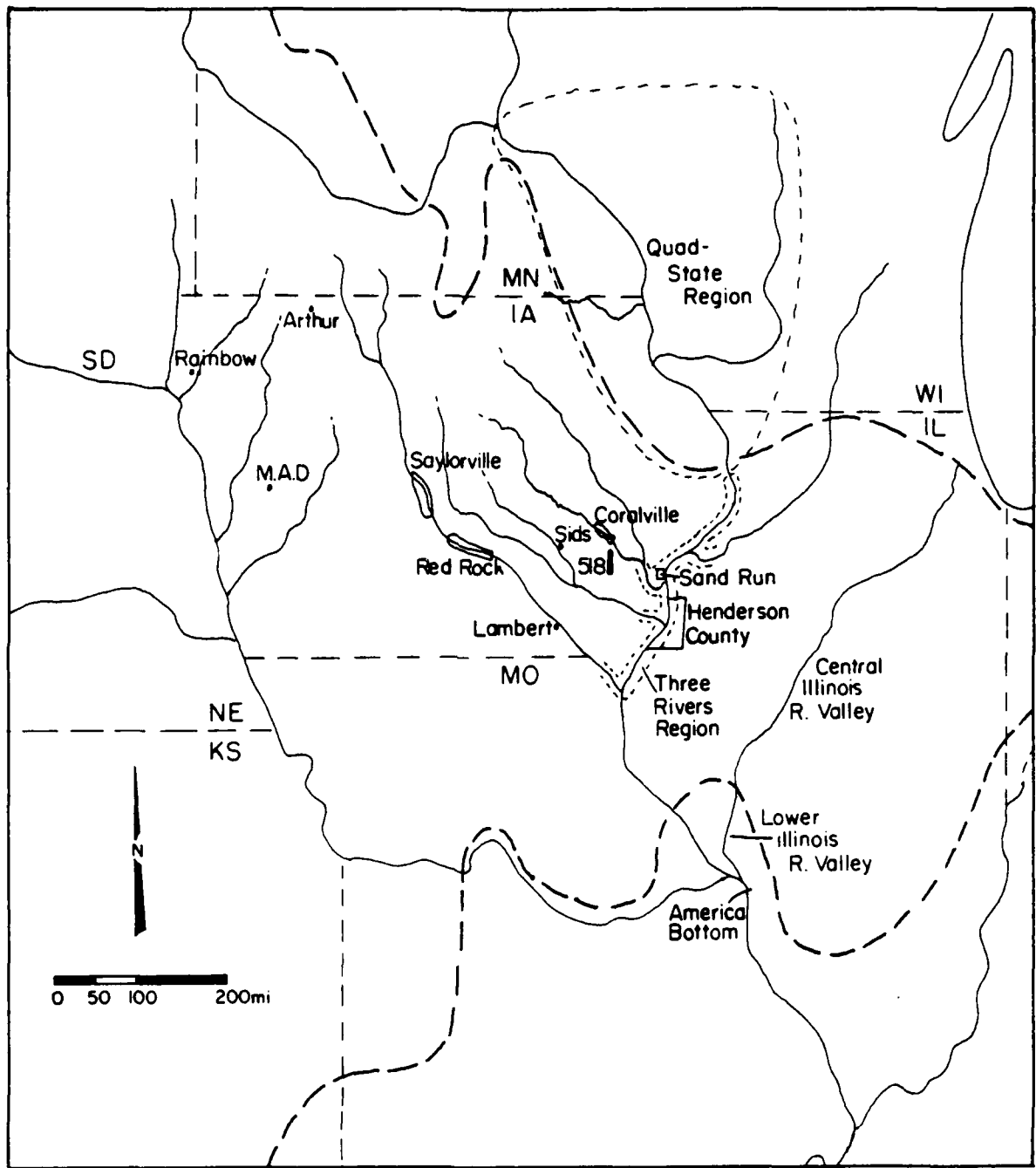
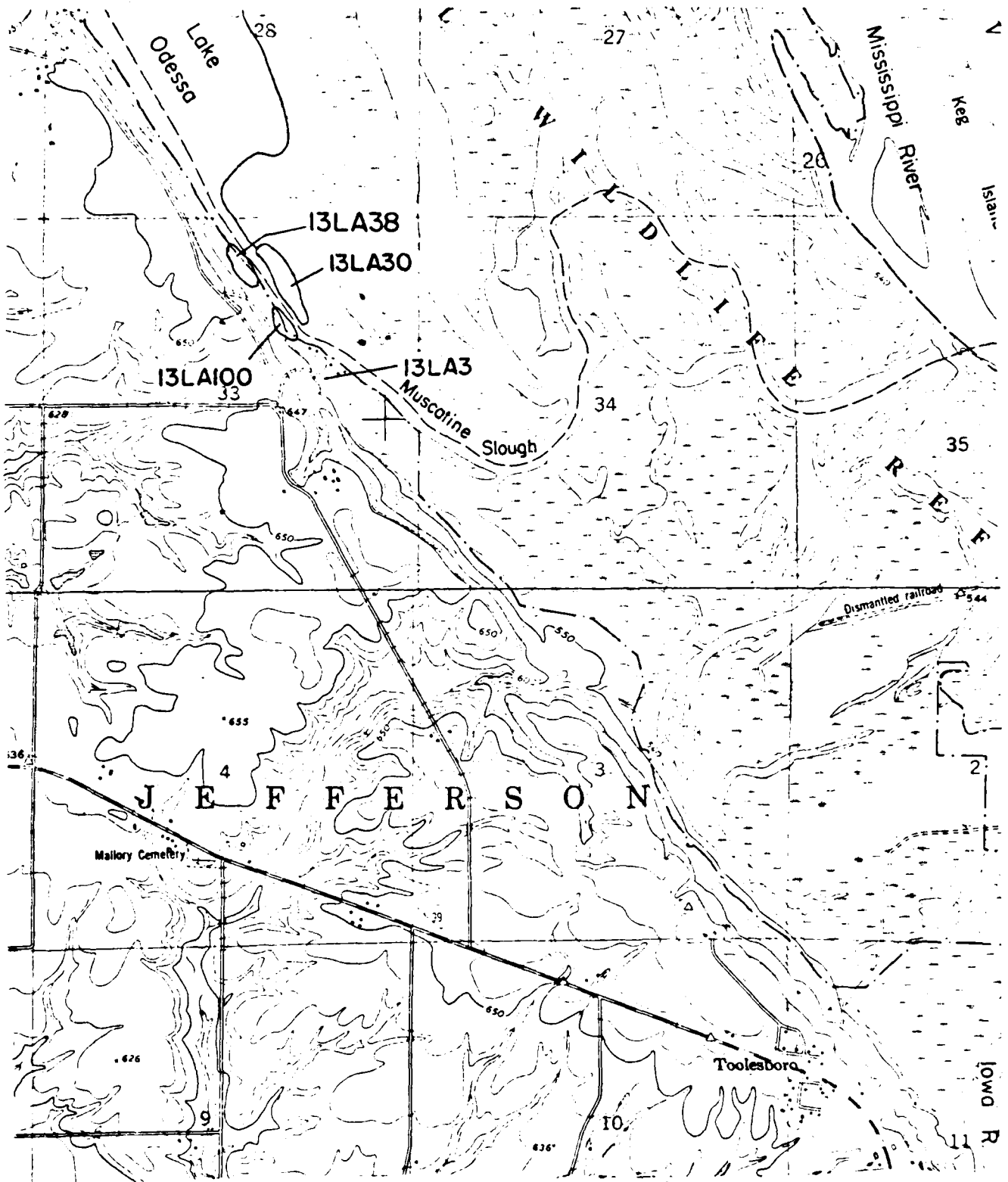
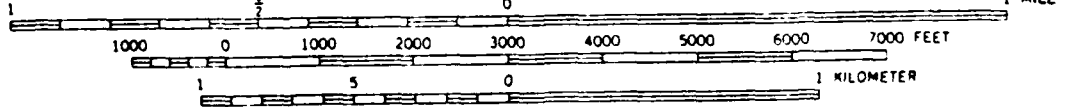
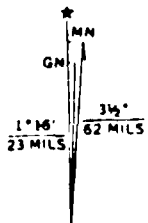

Figure 1.1: The location of Sand Run on the Prairie Peninsula (above), and in the Sand Run locality (right)





SCALE 1:24 000



CONTOUR INTERVAL 10 FEET

From: USGS Toolesboro quadrangle.





## II METHODS, EXCAVATIONS & STRATIGRAPHY

Sand Run Slough is part of the fluvial system on Muscatine Island, a backwater of the Mississippi River. Muscatine Island is leveed. Its high water level is determined by gradual seepage from the river channel during flood stage on the Mississippi River, and its low water level is controlled by a pump-back system. During normal years low water (ca. 535ft ASL) is achieved during August, then the water level is raised a few feet to accommodate fall season duck hunting in the marshes. During 1986, spring, summer and fall floods on the Mississippi River kept water levels high on Muscatine Island. The water level never dropped enough to expose normal beach lines, and much of the year the water level was near bankful.

Crews of archaeologists and local people entered the wet Sand Run Slough locality to excavate the site during the third week of May and during August. Although the timing of the excavations was disrupted due to water levels, the two-part excavation scheme was carried out as originally proposed. The initial phase of testing in May was intended to recover diagnostic material from stratigraphic contexts and to delineate locations for future block excavations. Then, the writer returned to the laboratory to process and analyze the excavated materials and to evaluate existing surface collections. The interim phase for evaluation was necessary for planning the block excavations to be conducted in the most efficient manner possible (field time and project funding were at a premium). Through the summer the crew waited for water levels to drop so that block excavations could be started. When the water dropped slightly and appeared to be on a downward cycle, the crew began excavating in late July. Through the subsequent 29 day field session, there were five days of heavy (+1in) rains, and the slough water level never dropped much below bankful.

### 13LA38

Sand Run Slough West site (13LA38) is a narrow (6-10m) band of cultural deposits along the eroding bank of the slough (Figures 1.1, 2.1). The site is in a forest of mature oaks and dense stands of small trees. The north and south ends of the site are demarcated by benches that extend from the sideslope to the bank. Between the benches and undulations of the steep sideslope are segments of nearly level river terrace in the footslope position. Two small (house-sized) alluvial fans interface with the terrace to form the context of the cultural deposit. The south fan is actively accumulating because it is fed by a gully from the county road above the site. The north

fan is stable today but has been active in the last 1000 years. In the lifetime of several local people the slough bank has eroded more than 10m into the site. Occasional chert flakes are seen in bare spots on the steep sideslope behind the site, but this is a deflated and non-significant part of the site. All of 13LA38 is contained within flood-prone land under the auspices of the COE.

Sand Run Slough Access site (13LA30) occupies the east (left) bank of the island across from 13LA38. Materials are found from the point across from the Sand Run boat access to ca. 300m upstream (i.e. past the north end of 13LA38). It is not known how far (east) and how deep the site extends into the island. This site is entirely terrace and is mostly flooded when water reaches the bankful stage.

The testing in May consisted of excavating four 1m test units in the fan and terrace deposits of 13LA38 (13LA30 was flooded) and beginning the site map (Figure 2.1). Two test units (#1,2) were positioned on the longitudinal axis of the north alluvial fan, a third unit (#3) was placed on the north apron of the fan, and the unit 4 was located on the terrace at the edge of the south apron of the fan. The south fan was too active to dig, and the lowest elevation on the terrace was too close to the water level. Excavation was by hand trowelling and shovel-skimming arbitrary 10cm levels. The damp clayey soils were not screened. A preliminary report of the testing results dated 13 June 1986 was sent to the COE. This report contained Figure 2.2, which represents the stratigraphy in the alluvial fan and terrace at 13LA38.

Three major soil horizons, sometimes splitting into 4-7 layers, were evident in the test units (Figure 2.2). A fourth test unit (#1 not shown) higher on the fan than I.U.2 contained only the upper and lower soils and little archaeological material (Appendix B). The soils were alfisols with relatively thin A horizons, pale (leached) E horizons and B horizons with clay accumulation. The surface soil sometimes split into two thin, closely-spaced sola (e.g. I.U.2,4), both of which contained ceramics and projectile points of the Late Woodland period (post-A.D. 600). The first major buried soil (3Ab in I.U.2,3; 2Ab in I.U.3) had an organic-rich A horizon and numerous cultural pits in the B horizon. This soil yielded Weaver, Havana and Black Sand ceramics (ca. 300 B.C.-A.D. 600) in no obvious stratigraphic arrangement. Woodland pits extended down to the lower buried soil (4Ab in I.U.4; 3 & 4Bb in I.U.3), a soil that yielded Osceola projectile points from I.U.2. In test unit 4 the 4Ab was organically rich and black. Soil 4Ab yielded practically no ceramics and was presumed to be the Late Archaic horizon. In test units 2 and 3 the additions of fan sediments had splayed the stratigraphy so that the lowest paleosol seen in I.U.4 was subdivided into three lighter colored soils. Each of these buried soils in I.U.2 contained a concentration of cultural

debris but no ceramics. Practically no Archaic aged material came from I.U.3.

In May, test Unit 1 reached a human digging limit of 2.5m, and soil probes to 3m in the bottom yielded no carbon or other human evidence. Units 2,3 and 4 were terminated at ground water level. A 100cm probe beneath the unit 3 floor encountered nothing but yellow sandy loam. Probes in unit 2 hit carbon flecks at 215cm depth but nothing else and no soil horizons. A probe in unit 4 reveal about 70cm more of soil and cultural midden (which later proved to be a pit) but no soils or cultural deposits below that. Because sandy sediments lacking soils were encountered beneath the test unit floors, it was assumed that no additional cultural horizons existed below ca. 2m.

The procedures for the August excavations were designed from the testing evidence. The surface of Sand Run West was gridded in 5m intervals after establishing a temporary datum at I.U.1 (oak stakes left in the ground) and a permanent elevation datum near Block B (a large nail in a large white oak tree; Figure 2.1). Three excavation blocks were gridded where openings in the large trees allowed sufficient space for digging and screening. Three blocks were established at test units: Block A at I.U.3, Block B at I.U.2, Block C at I.U.4. Stratum I was designated as the topsoil(s), i.e. the Late Woodland levels. Stratum II encompassed the middle buried soil, i.e. the Middle and Early Woodland components. Stratum III was the lower buried soil, the Archaic component(s). In Block B (I.U.2) the lower soil was subdivided (top to bottom) into Strata IIIa, b and c according to the three thin paleosols. The top of each stratum began at the top of each buried A horizon, and strata were excavated by arbitrary 10cm levels.

Excavation floors were oriented to the strike and dip of the paleosols by probing ahead of the level being excavated. Excavation was by hand trowelling, shovel-skimming and screening (quarter inch) cultural levels and shovel-skimming sterile levels. Field bags were marked for the grid provenience and by level within each stratum. Only diagnostic chipped stone artifacts and ceramics were piece-plotted in the field.

Block A covered seven square meters, including I.U.3--all the space that could be found between huge trees. This block was excavated for the Late and Middle Woodland components in strata I and II. After nine days, Block A was abandoned when Stratum II had been excavated.

Block B was opened to probe the buried Middle Woodland and Archaic components. The block began as 10 square meters, including I.U.2, and was expanded later to a 12 square meter rectangular block. Almost no cultural material came from Stratum I levels 1-4 in two squares (I.U.2, 1N8E), so the remainder of levels 1-4 in the block was shovelled away. The rest of Stratum I (levels 5,6) and Stratum II (levels 7-10) was excavated by

hand. The Bb horizon of Stratum II had no cultural midden but was pockmarked by cultural features extending below level 9. After removing the features, only two of which extended to the Archaic levels below (see Fea. 1, Figure 2.2), the rest of the sterile Bb horizon of Stratum II was shovelled out of the block. Hand excavation then proceeded through strata IIIa, IIIb and IIIc, each time removing a thin cultural midden in a buried A horizon and then removing cultural features from the Bb. Test Unit 2 was excavated to a depth of 290cm (ground water) ahead of the Block B work to check for additional cultural deposits. None were located, and the Block B excavation was terminated at 200cm.

Block C consisted of a 12 square meter rectangular block, including T.U.4. A one meter square was added at the northeast corner at the end of the session to obtain soil samples from general excavation levels. Test Unit 4 was excavated to a depth of 230cm (ground water), again to check for deeper cultural deposits. None were found beneath Stratum III. The entire Block C excavation proceeded by hand trowelling and screening 10cm levels to a final depth of 150cm, the base of the Stratum III midden. From the ground surface to the bottoms of the Archaic features at +150cm the soil in Block C was dark gray-brown or black and filled with cultural artifacts (see Appendix B soil descriptions). Slightly lighter brown soil was discerned in the upper two B soil horizons, and the 4Bb horizon below Stratum III was yellow-brown. Because of the dark soil, Woodland features were almost impossible to identify. Thus, the excavation floor was trowelled clean at level 4 (the B horizon for Stratum I) and levels 11 and 12 (the lower 3Bb of Stratum II and upper 4Ab for Stratum III) to search for pits. At levels 14 and 15 the dark Archaic pits showed clearly against the yellow sediments of the 4Bb horizon. Unfortunately, ground water was encountered at the level of Archaic pits in the lower (southeast quadrant) of the block. Water turned pit fill into mud and rendered screening a messy business.

To complete the site stratigraphic profile, Test Units 5, 6 and 7 were excavated. Units 6 and 7 were placed at 5m intervals across the fan between Blocks B and C. Both units were excavated through Stratum III to a depth of 160cm. Unit 5 was placed on a lower terrace elevation 17m south of Block C. It was excavated through Stratum II to a depth of 100cm before hitting ground water. Initially, unit 5 was intended to be the location of a fourth block, but rising water levels cancelled this notion.

The total amount of excavations on 13LA38 was 35 square meters and 52 cubic meters. All excavations were backfilled by hand, since machinery could not reach 13LA38 through the forest and over wet ground. Artifact collections are catalogued and boxed for storage. The disposition of collections is not decided, but they will be stored in Iowa. Written and photographic records are stored at the Center for Archaeological Research.

## 13LA30

The Sand Run Access Site (13LA30) is on an island. The island's sediment source is river alluvium without alluvial fans that are present at 13LA38. Site 13LA30 is about 1m lower in elevation and prone to flooding when 13LA38 is higher and drier. During the May and August field sessions, 13LA30 was watched for the moment when the water level dropped low enough to expose stratigraphy on the bank and to allow for excavation. This never happened. At the end of the August field session, a morning was spent digging a stratigraphic pit directly across the slough from the red cabin south of 13LA38. This pit reached 120cm depth--well below the slough water level, although experience on 13LA38 proved that ground water permeated slowly through loamy soils and eventually filled deep pits within 48 hours.

## Radiocarbon Dates

About a dozen carbon samples were retained from all components in the 13LA38 excavation, and carbon was floated from most of the feature soil samples. The stratified Archaic components in Block B yielded the most samples, and Stratum I had only one sample. Much of the carbon was soft and weathered into small pieces, and several of the largest samples were composed of bark. When processed with water, some of the "best" samples (i.e. ones from the clearest contexts) disintegrated. One of the lost samples was the deepest from 270cm in T.U.2. Four samples were run at the Beta Analytic Laboratory, giving results that correlate with the site stratigraphy and with previously known cultural periods. The ages are presented uncorrected.

950+70 B.P.: A.D. 1000 (Beta-17665): This date was taken from solid charcoal deposited with a ceramic vessel and fire-cracked rocks (Fea. 3) in level 3 Stratum I Block A. The vessel has a globular body and uniform, low-relief exterior cord roughening (Figure 3.2b) typical of Late Woodland (Minotts ware) vessels in eastern Iowa.

1760+80 B.P.: A.D. 190 (Beta-18292): Carbon floated from features 4 and 31 was combined to create this sample. Both features were pits extending from the Stratum II midden below level 9 in Block B. Feature 31 contained one Levsen Dentate Stamped sherd and one Havana Cordwrapped Stick Stamped sherd, both late Middle Woodland period pottery types.

4140+110 B.P.: 2190 B.C. (Beta-18293): This carbon came from a sample removed in the field from the bottom of a roasting pit, feature 18 in Stratum IIIa Block B. The sample came from a context unmixed by other components of the Late Archaic or Woodland levels.



4270±90 B.P.: 2320 B.C. (Beta-17937): This was a massive sample of carbonized bark and wood on the bottom of feature 28, a roasting pit in Stratum IIIc Block B.

### Geomorphology, Pedology & Cultural Stratigraphy

by E. Arthur Bettis III (Iowa Geological Survey Bureau) and David W. Benn

The Sand Run West site is situated at the base of a steep bluff along the western (right) wall of the Mississippi River valley in Louisa County (Figure 1.1). The site is bordered on the east by Sand Run Slough which functions as the southern outlet for Lake Odessa, an abandoned Mississippi River channel. The Iowa River, a major right bank tributary of the Mississippi River, joins the master stream approximately 8km (5mi) southeast of the site. The upland immediately to the west and about 33m (100ft) above the site is part of the loess-mantled Illinoian till plain of southeastern Iowa and adjacent Illinois. On the upland 3-5m of late Wisconsinan-age Peoria Loess buries the Sangamon Soil developed in the early Illinoian-age Kellerville Till Member of the Glassford Formation (Hallberg 1980; Hallberg et al. 1980). Glassford Formation deposits bury older, Pre-Illinoian-age glacial deposits of the Wolf Creek and Alburnett Formations. Depth to bedrock in this area varies from 61-76m in the uplands (Hansen 1973). Depth to bedrock in the Mississippi trench is unknown, but it is well below the level of bedrock beneath the uplands.

The Mississippi Valley in Louisa County, Iowa and adjacent Mercer County, Illinois is composed of a mosaic of landforms and underlying sediments of varying age and origin. The oldest alluvial landform in this valley reach is the high sandy terrace on the east side of the valley in Mercer County. The surface of this landform, known as the New Boston Terrace, lies between 560ft and 580ft ASL and has the town of New Boston located on its western limit (opposite the confluence of the Iowa and Mississippi rivers). The New Boston Terrace was the active floodplain during the latest Wisconsinan period when the Mississippi River carried sandy and gravelly outwash from glaciers located in Minnesota, Wisconsin and Illinois. Approximately 10,000 B.P. the Mississippi River entrenched into the late glacial floodplain when relatively sediment-free water from glacial lakes, such as Lake Agassiz, flowed down the valley. This entrenchment topographically separated the New Boston Terrace from the early Holocene floodplain.

The large terrace complex between the New Boston Terrace and the present Mississippi channel probably accumulated during the early and middle Holocene (ca. 10,000-4500 B.P.) as the river migrated west in this valley reach. By ca. 4500 B.P. the Mississippi channel was against and actively eroding the western

valley wall. Investigations by Bettis and Hoyer at the Michaels Creek Fan (Bettis and Hoyer 1984:2.9-2.18), located 7.2km (4.5mi) north of Sand Run, disclosed that Lake Odessa was the active Mississippi channel before ca. 4000 B.P. The western bluffline of the valley from Klum Lake in the north to the Iowa River junction at the south end of Muscatine Island is a very young feature--Middle Holocene in age. The evidence for the youthfulness of the bluffline is two-fold. Large slump blocks are actively moving down the bluff slope. Additionally, several upland valleys draining to the west into the Iowa River valley were beheaded during the westward movement of the Mississippi channel. Many of the valleys of the Iowa drainage system now have short steep Mississippi tributaries in their former headwater areas.

Alluvial fans and colluvial slopes are located along the lower flanks of the steep western valley wall of the Mississippi River. These features began developing immediately after the main Mississippi channel shifted away (east) from the west valley wall. At the Michaels Creek fan, Bettis and Hoyer (Ibid.) found that the fans and associated colluvial slopes at the north end of Lake Odessa began developing shortly before 4500 B.P. Stratigraphic relationships and radiocarbon dates from the Sand Run investigations allow us to extend this landform pattern to the south end of Lake Odessa.

At the Sand Run excavations detailed descriptions of block walls were made using standard USDA-SCS methods and terminology (Soil Survey Staff 1951, 1975; Bettis 1984). Colors are standard Munsell. Profiles were sampled in the field and analyzed for particle size distribution (Walter et al. 1978) and for organic carbon content (Walkley-Black method) at the Iowa Geological Survey Bureau soils laboratory.

Block profiles studied for detailed descriptions were 58SR1 on the west wall of Block B near the center of a small alluvial fan (Figures 2.1, 2.3, 2.5) and 58SR2 on the west wall of Block C on the downvalley side of the fan (Figures 2.1, 2.4, 2.5; Appendix B). Three depositional units (Strata I, II, III top to bottom) and several subunits (lettered a-c top to bottom) were recognized in the excavations. The top of each unit or subunit was marked by a paleosol surface. Significant modification of the original deposits occurred during prehistoric occupation of the site. Some of this modification probably occurred during the accumulation of the sediments. The most obvious form of alteration was the extensive pit digging by aboriginal inhabitants. This activity acted to mix soil horizons and sometimes obliterated the contact between depositional units (strata). Another form of cultural modification of the deposits was the significant addition of organic matter, artifacts and other refuse. These additions resulted in the formation of middens which now dominate the character of the site deposits.

Each depositional unit consisted of loamy alluvial and colluvial deposits which have their coarsest size fraction (usually fine-medium pebbles) in the lower part of the unit. This is a typical alluvial fan sedimentary sequence (Hoyer 1980; Bettis and Hoyer 1986). The fan sequence is produced by an initial episode of rapid sedimentation during which relatively coarse material is eroded from the contributory basin (i.e. a nickpoint in the steep valley wall adjacent to the site at Sand Run) and deposited on the alluvial fan. This is followed by episodes of slower, increasingly less frequent sedimentation of finer grained materials. As sedimentation slows, pedogenesis occurs in the upper part of the sediment package. After a period of relative stability when there is little or no sedimentation, the sequence of events repeats and the former fan surface is buried. This fan sequence is illustrated by the strata IIIc,b,a, II and I soils and intervening sediments in the Block B stratigraphy (Figure 2.5).

At Sand Run the Mississippi River deposits are buried by and interfinger with the alluvial fan deposits. The Mississippi River deposits are loamy like the fan deposits, but the former have fewer pebbles, contain much less coarse sand grains and are better sorted (i.e. have less variable grain size). The greater sorting of the Mississippi River alluvium is evident when comparing the particle size profiles of description 58SR1 (Block B), located on the northern alluvial fan, with 58SR2 (Block C), located on the fan margin closer to Sand Run Slough (see descriptions, Appendix B). Mississippi River deposits are the dominant facies in the lower part of Block B (below 257cm) and occupy all of depositional unit III in Block C.

Radiocarbon dates permit rough estimates of sedimentation rates at the site. In Table 2.1 calculated sedimentation rates are low, ranging from .02 to .12cm/yr. The highest rate is calculated for Stratum III in Block B, the zone of coarsest alluvial fan deposits (see especially IIb). The sedimentation rates have little meaning other than to indicate that most of the last 4500 years witnessed relative stability and soil formation.

Table 2.1  
Estimated Sedimentation Rates at Sand Run

Location	Thickness	Years	Rate
Block B I	64cm	800	.08
Block B II	66cm	2200	.03
Block B IIIa	23cm	200	.12
Block C I	42cm	800	.05
Block C II	41cm	2200	.02

Organic carbon content of the Sand Run deposits provides evidence for significant additions of organic material to the alluvial/colluvial sediments. Increases in organic carbon content (Appendix B) occur at or near the surface of all the paleosols. These increases are both natural and cultural in origin. Organic carbon content is naturally higher in the A soil horizon. However, the total amount of organic carbon in the Sand Run deposits is greater than normal for a moderately well to well drained soil developed under forest vegetation in Iowa.

The soils at Sand Run West are mapped as the Douds-Lindley complex, a grouping of soils formed in sandy, loamy and pebbly (Lindley) sediments in the footslope position (Brown n.d.). Olmitz loam, a soil formed in coarser deposits on alluvial fans, also is typical of the Sand Run West location (Ibid.). The Sand Run soil profiles (Appendix B) show more complex horizonation than the type profiles for these soil series. Associated diagnostic artifacts and radiocarbon dates indicate periods of stability and pedogenesis were roughly uniform across the site (Figure 2.5). Comparison of the morphology of the modern surface soil with the two prominent buried soils (II, III) suggests that the buried soils represent about the same degree of development as the surface soil. All exhibit a similar degree of clay translocation into the B horizon of the three major soils. That the soils of Blocks B and C do not have the same thickness is the result of different rates of sedimentation on the fan and terrace. Close examination of the profiles reveals that the surface and buried soils actually consist of two or more soils which are closely spaced and, in some cases, not distinguishable.

The age of A.D. 1000 for Stratum I dates the period when development of the surface soil began. Feature 3, which produced the datable material, was a shallow basin where trash was disposed on the prehistoric ground surface. Since that event another 20cm of sediment has accumulated over the feature. Also since that event the uppermost .5m of the profile has weathered sufficiently to result in a moderately developed Alfisol at the present ground surface.

The date of A.D. 190 approximates the end of an episode of soil formation which resulted in the Stratum II soil. This conjecture is based on the position of several pits in Blocks A, B and C profile walls. A number of pits with bottoms in the Bb horizon extended up to the 2ABb or even the 2Ab horizon before their distinctive coloration vanished in dark A horizon colors (Figures 2.6, 2.3, 2.4). Furthermore, two pits in Block B clearly cut through the 2Ab from its surface (#3,5; Figures 2.3, 2.5). Thus, the cultural component was concentrated on the surface and in the upper 10cm of the buried A horizon. This relationship holds for the Stratum II pits in Block A. Of course, the contents of Stratum II in Blocks A and B belong (typologically) to the late Middle Woodland period. There are earlier Middle and Early Woodland materials throughout Stratum II

and Block C, so materials of these ages must predate A.D. 190 and originally were deposited deeper in Stratum II.

The degree of mixing between strata soils is illustrated best by the distribution of typed ceramics in Tables 2.2, 2.3 and 2.4. In all three blocks the Middle Woodland component (i.e. Havana Ware) is in Stratum II. Some sherds infused into the upper horizon of Stratum III due to disturbances, and other Havana sherds were brought into Stratum I (Blocks A, C) by subsequent cultural activity. Where the strata were most compacted in Block C, mixing is more evident. In the thickest deposits at Block B, no mixing up or down is evident. In Blocks A and C the distribution of weaver pottery (late Middle to early Late Woodland periods) straddles the strata I/II boundary just as pits were observed to cut this boundary (see previous paragraph). The disposition of Liverpool and Marion potteries (Table 2.4) seems to show the most evidence of mixing. Marion, the earliest ware, has been moved upward in the profile, as has Liverpool ware to a lesser extent (Liverpool ware may be contemporary with Havana--see CERAMICS). These wares were the first to be deposited in the Stratum II soil, and they were scattered by subsequent intense pit digging activity during the Havana occupation.

Stratum III is easiest to analyze in Block B where higher sedimentation rates have separated the Late Archaic into components about 200 years apart. The soil in Stratum IIIa is developed into the soil in IIIb (Figures 2.3, 2.5). On the west wall (Figure 2.5) a cultural "surface" in IIIb dips toward a roasting pit, feature 24. This was the only "surface" noted during the excavations, and it was defined only after the profile walls were studied. Perhaps the surface was a house floor. Stratum IIIc was not defined as a soil in the block excavations, only in the original T.U.2 (Figure 2.2). A fortunate circumstance of excavation exposed the most stratified portion of the fan in the northeast corner of Block B (stake 9E4N, Figure 2.3). Here, the Stratum IIIa soil separated into two soils with an intervening feature (#34), IIIc had soil development, and an empty pit (feature 29) had been filled slowly with sediments and culture debris of at least three components. This is a total of seven verified components for all of Stratum III. Clearly, the excavation strata do not represent actual single occupations, rather they are components of similar but mixed materials that happen to be deposited in soil horizons.

Across the slough at the Sand Run Access site (13LA30) a soil profile pit was dug to compare with 13LA38. The island soils are mapped as the Coland-Perks-Lawson complex, a group of bottomland soils with thick, dark loamy and sandy A horizons (Brown n.d.). In the profile pit the same tripartate soil sequence was present with fragments of burned earth, a chert flake and occasional fire-cracked rocks. The surface soil was dark gray to brown loam with a morphologic expression similar to the surface soil at 13LA38 but lacking an E horizon. A buried

soil located between 50-90cm was similar to but darker and heavier textured than the stratum II soil at 13LA38. The lowest soil, not completely exposed, was black and heavy textured like the Stratum III soil. Generally, the alluvial sediments at 13LA30 are heavy textured because they are in an island environ where overbank deposition of silt and clay predominates.

### Cultural Features

Features were recognized where concentrations of the same kinds of materials were found or where pit digging activity had occurred. In the field, features were numbered consecutively in each block and test unit (e.g. 1A, 23B, T.U.7-1, etc.; Figures 2.7-2.19), and feature descriptions and profiles were recorded on separate sheets for permanent accessioning. Excavation of hearth and pit features was by sectioning. Soil samples were taken after the cross-section profile had been recorded.

The types of features consisted of two smashed ceramic vessels, two piles of rocks, a post hole, several diffuse hearths lacking excavated basins, deep roasting pits, one or more "dog burials" and a large number of basin and cylindrical shaped pits (Figures 2.7-2.18). One broken vessel with rocks and carbon was feature 3 Stratum I in Block A. Another was a broken Baehr/Pike vessel probably in a pit (feature 5a) at the bottom of Stratum II Block C. The rock piles (features 21, 26) in Stratum III Block B appeared to be small basket-loads of fire-cracked rocks and tools (see "Cobble Tools"). The post hole (feature 17; Figure 2.10) at the bottom of Stratum II Block B was 40cm deep and pointed. Hearths without basins were difficult to delineate. They consisted of small (25-40cm), mottled spots of burned-orange soil (e.g. feature 10 Block A, feature 3 Block C; Figure 2.8). Hearths established on the ground surface of loamy soils often become diffused in archaeological contexts. In contrast, roasting pits were clearly defined. These were deep, basin shaped pits with burned-orange and black edges and fills of mottled burned soil or layers of carbon and midden (e.g. features 2/20, 9, 18, 24, 32 Block B; Figures 2.11-2.16). Small fragments of fire-cracked rocks occurred in the orange fills but large concentrations of fire-cracked rocks were not found in roasting pits.

The remaining type of feature was the pit, which was filled usually with dark midden soil. Pits varied in size from 20cm to 1m in diameter. Most were basin shaped and less than .5m deep, while a half dozen Middle Woodland pits were deeper and with cylindrical sides (e.g. feature 5b Block C, feature 5 Block B; Figure 2.18). The two mostly intact canid skeletons came from pits--one each from strata II and III Block C (Figure 2.17). One was dog-sized (feature 4), and the other larger one (wolf?) came from the Late Archaic feature 12. No notable concentrations of non-local materials were recovered from pits, nor were numerous fill zones or evidence of seasonality indicated in pits.

The overlap of features in all strata indicates that there were multiple episodes of activities. This was confirmed in the cultural stratigraphy as well (see above). The excavation blocks were too small to confidently define activity areas around features. Therefore, the horizontal distributions of features and piece-plotted materials in blocks probably are not significant (Figures 2.7, 2.9, 2.11, 2.13, 2.15, 2.17). Surely, this is true for Stratum II Block B (Figure 2.9), where features were overlapped at least three times.

In Block B a pattern emerged of most hearths in the eastern half of the block in strata II and III. This may be a figment of house positions on the site: i.e. a line of structures placed against the backslope of the bluffline would result in hearths being concentrated in the excavation blocks.

Another pattern seen in the profiles is that Woodland pits tended to be larger and deeper than Late Archaic pits. Most of the Late Archaic pits were roasting features, not storage pits--the presumed function of Woodland pits. Increased use of pits during the Woodland periods correlates with other parts of the productive system, specifically intensive native seed horticulture and caching of materials in anticipation of exchange.

Table 2.2  
 Typed Ceramics from Block A Excavations  
 13LA38

Stratum lev	Late W. C.I.	CR b.s.	Weaver Plain	Levsen	Baehr	Havana Incised	Havana Zoned Den.	Havana CWS	Naples
I	1	21	-	-	-	-	-	1	-
	2	65	-	2	-	-	-	-	-
	3	35	1	1	-	-	1	-	-
	4	12	3	-	1	-	-	-	2
Fea(#)	-	(3)ves	1(3)	-	-	-	-	-	-
II	5	-	1	-	-	-	-	-	2
	6	1	-	-	-	1	-	-	2
	7	-	-	-	1	-	-	-	1
Fea(#)	-	-	1(5)	-	1(9)	-	1(8)	1(1)	3(1) 3(9)

Table 2.3  
 Typed Ceramics Block B & TU 6, 7

Stratum lev.	Late Wood C. I.	Late CR b.s.	Weaver Plain	Trailed	Levsen CWS	Levsen Den.	Havana Incised	Havana Zoned Den.	Havana CWS	Hummel	Naples
I	3-4	-	-	-	-	-	-	-	-	-	-
	5	7	-	-	-	-	-	-	1	-	2
	6	11	-	-	-	-	-	-	-	-	-
Fea(#)	-	(16) 1	(17) 1	(7) 1	-	(31) 1	(9) 1	(7) 1	(7) 5	(7) 1	(3) 1
II	7	4	-	-	1	-	1	-	-	-	1
	8	1	2	-	-	-	-	-	1	-	2
	9	-	-	-	-	-	-	-	-	-	-
Fea(#)	-	-	(9) 1	(7) 1	-	(31) 1	(9) 1	(7) 1	(4) 1	(7) 1	(9,10) 5
	-	-	(7) 1	-	-	(6) 1	(6) 1	(6) 1	(10) 1	(10) 1	(10) 1
	-	-	(6-3) 1	-	-	-	-	-	-	-	-



Table 2.4  
 Typed Ceramics Block C & TU 5

Stratum	lev	Late W		Late CR		Weaver		Levsen		Hopewell		Pike/ Zoned		Havana		Havana		Havana		Motion		Sister		Liverpool		Black		Marion			
		C.I.	b.s.	Plain	Trilled	Den	Hopewell	Den	Den	Den	Den	Den	Den	Den	Den	Den	Den	Den	Den	Den	Den	Den	Den	Den	Den	Den	Den	Den	Den	Den	
I	1	2	3	-	-	-	-	-	-	-	-	-	-	-	-	-	-	-	-	-	-	-	-	-	-	-	-	-	-		
	2	3	13	-	-	-	-	-	-	-	-	-	-	-	-	-	-	-	-	-	-	-	-	-	-	-	-	-	-		
	3	2	60	1	-	-	-	-	-	-	-	-	-	-	-	-	-	-	-	-	-	-	-	-	-	-	-	-	-		
	4	11	80	1	-	-	-	-	-	-	-	-	-	-	-	-	-	-	-	-	-	-	-	-	-	-	-	-	-		
	5	2	41	4	-	-	-	-	-	-	-	-	-	-	-	-	-	-	-	-	-	-	-	-	-	-	-	-	-		
	fea(1#)																														
II	6	3	16	6	-	-	-	-	-	-	-	-	-	-	-	-	-	-	-	-	-	-	-	-	-	-	-	-	-	-	
	7	3	1	2	2	1	-	-	-	-	-	-	-	-	-	-	-	-	-	-	-	-	-	-	-	-	-	-	-	-	
	8	-	-	5	-	-	-	-	-	-	-	-	-	-	-	-	-	-	-	-	-	-	-	-	-	-	-	-	-	-	
	9	1	1	-	1	-	-	-	-	-	-	-	-	-	-	-	-	-	-	-	-	-	-	-	-	-	-	-	-	-	
	fea(1#)																														
III	10	-	-	-	-	-	-	-	-	-	-	-	-	-	-	-	-	-	-	-	-	-	-	-	-	-	-	-	-	-	-
	11	-	-	-	-	-	-	-	-	-	-	-	-	-	-	-	-	-	-	-	-	-	-	-	-	-	-	-	-	-	-

Key: W=Woodland, CI=cord impressed, CR=cord roughened, bs=body sherd, Den=dentate, CMS=cord-wrapped stick, CM=cord marked, decor=decorated, fea=feature

Table 2.5  
13LA38 Feature Data

Block/Test Unit						
Fea.	Level	Size (horiz. x depth)	Type	Contents		
Block A						
1	II-5	74dia x +16cm	pit	fcr. flakes, bones, Havana ware		
2	II-6	65dia x +11cm	pit	carbon, flakes, fcr		
3	I-4	28dia x +8cm	vessel	carbon, fcr, Minotts pottery		
4	II-5	86dia x +21cm	pit	carbon, burned earth, fcr		
5	II-6	105dia x +30cm	pit	carbon, fcr, flakes, Weaver ware		
6	II-6	50dia x +6cm	pit	carbon, fcr, flakes		
7	II-6	90dia x +11cm	pit	flecks of midden		
8	II-6	91dia x +24cm	pit	carbon, flakes, fcr, Havana ware		
9	II-6	+100dia x +32cm	pit	carbon, flakes, fcr, Havana ware		
10	II-6	44dia x +5cm	hearth	burned earth		
T.U. 6						
1	II-10	50dia x +10cm	pit	carbon, burned earth, 2 sherds		
2	II-10	+50dia x +29cm	pit	burned earth, mixed soil		
3	II-10	+60dia x +9cm	pit	fcr, flakes, Weaver vessel		
T.U. 7						
1	III-16	+100dia x 18cm	hearth	burned soil, midden flecks, fcr		
Block B						
1	II-8	100dia x 60cm	pit	midden flecks, fcr, sherds, flakes		
2	IIIa-13	100x20 x 27cm	pit	fcr, flakes, bones, Osceola pt.		
3	II-8	65dia x +25cm	pit	flakes, fcr, carbon, Havana ware		
4	II-8	108dia x +29cm	pit	flakes, fcr, carbon, Havana ware		
5	II-8	70dia x +21cm	pit	carbon, fcr		
6	II-8	+70dia x +33cm	pit	flakes, fcr, carbon, Havana ware, Gibson pt.		
7	II-8	180x140 x +20cm	pit	flakes, bones, fcr, Weaver & Havana wares, Manker pt.		
8	II-8	70dia x +10cm	pit	flakes, sherds, bones, fcr, carbon		
9	II-8	100dia x +50cm	pit	flakes, fcr, bones, carbon, Weaver & Havana wares		
10	II-8	98dia x +20cm	pit	flakes, fcr, Havana ware		
11	II-8	75dia x +18cm	hearth	flakes, fcr, sherd, carbon		
12	II-8	80dia x +30cm	pit	flakes, bone, sherds, carbon		
13	II-8	+90dia x +10cm	pit	flakes, fcr, carbon, biface		
14	II-8	20dia x +20cm	pit	flakes, carbon		
15	II-8	90dia x +20cm	hearth	carbon		
16	II-8	90dia x +28cm	hearth	flakes, carbon, Late Wood. sherd		
17	II-10	13dia x +42cm	post	flakes, carbon, sherds, net weight Havana ware		
18	IIIa-12	90dia x +40cm	pit	flakes, fcr, carbon, bones		
19	IIIa-13	66dia x +8cm	hearth	burned earth		
20/2	see above					
21	IIIa-13	40dia x 10cm	dump	fcr		
22	IIIa-13	+70dia x +10cm	hearth	carbon, burned bone		
23	IIIb-15	90dia x +13cm	hearth	carbon, bone, fcr, drill frag.		

24	IIIb-16	60dia x 39cm	hearth	layers of carbon, midden, fcr
25	IIIb-17	110x60 x +10cm	pit	carbon, bone flecks
26	IIIc-18	30dia x 8cm	dump	basket load of fcr, bone bits
27	IIIc-18	26dia x +13cm	pit	carbon, fcr, cobble
28	IIIc-18	60dia x +20cm	hearth	carbon, fcr
29	IIIc-18	100dia x +30cm	pit	carbon, bones
30	IIIc-30	100dia x +10cm	pit	flakes, fcr, bone, carbon
31	II-8	+70dia x +30cm	pit	flakes, fcr, carbon, Levensen ware, flake point
32	II-8	80dia x +8cm	hearth	flakes, fcr, carbon, Havana ware
33	IIIa-12	72dia x +18cm	hearth	fcr, flakes, carbon
34	IIIa-15	80dia x +30cm	pit	flakes, carbon, bone
35	IIIb-15	120dia x +30cm	pit	flakes, carbon, bone
36	IIIb-15	60dia x 10cm	hearth	fcr, burned bone
37	IIIc-18	50dia x +18cm	hearth	flakes, fcr, bone, carbon
38	IIIc-18	75dia x +31cm	pit	hammerstone, fcr, flakes

Block C

1	I-3	68dia x 3cm	hearth	burned earth, sherds
2	III-15	80dia x +16cm	pit	flakes, fcr, bone, carbon
3	II-8	23dia x 6cm	hearth	flakes, fcr, carbon, Havana ware
4	III-105	30dia x 5cm	(pit?)	"dog" skeleton
5a	II-11	30dia x 5cm	(pit?)	crushed Pike vessel
5b	II-11	90dia x +40cm	pit	flakes, fcr, Pike sherds, pipe bowl
6	III-12	15dia x 8cm	pit	carbon concen.
7	III-14	80dia x +24cm	pit	flakes, fcr, bone, carbon
8	III-14	87dia x +26cm	pit	carbon, flakes, fcr
9	III-14	56dia x +18cm	pit	flakes, fcr, bone, carbon
10	III-14	+95dia x +10cm	pit	fcr concen., carbon
11	III-13	+60dia x +38cm	pit/post	flakes, fcr, carbon
12	III-14	60dia x +10cm	pit	flakes, fcr, "dog" bones, carbon
13	III-15	80dia x +10cm	pit	flakes, bone, fcr, carbon, ax frag
14	III-14	120dia x +16cm	pit	flakes, fcr, bones, carbon
15	III-15	+80x60 x +31cm	pit	flakes, fcr, bones, carbon
16	III-14	+80dia x +20cm	pit	fcr, carbon
17	III-14	41dia x +15cm	hearth	bone, carbon, flakes

# Sand Run Slough—

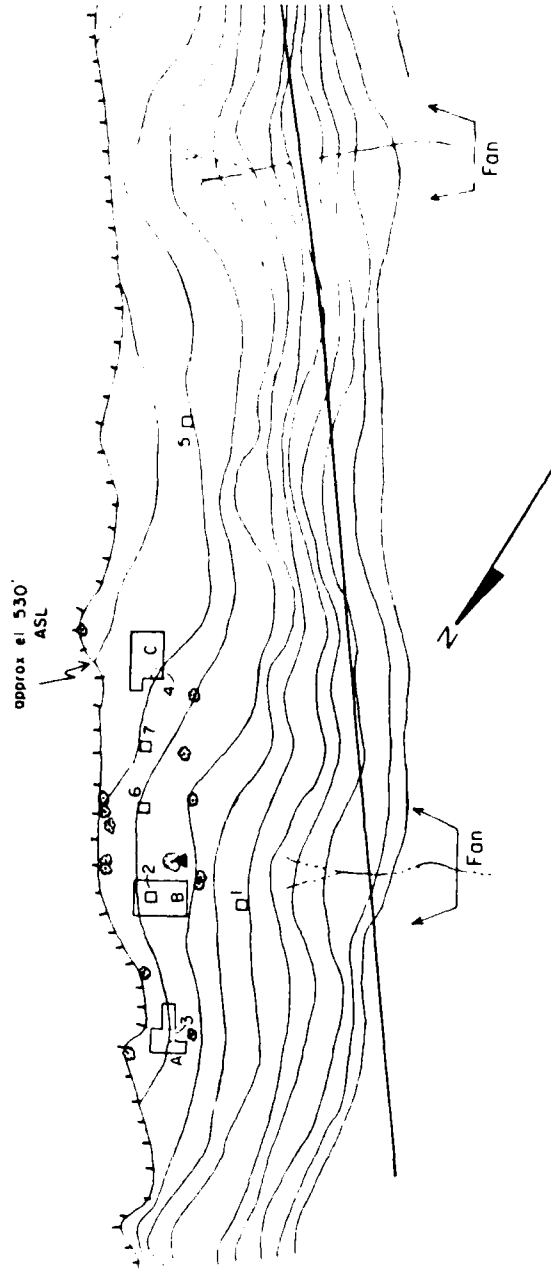
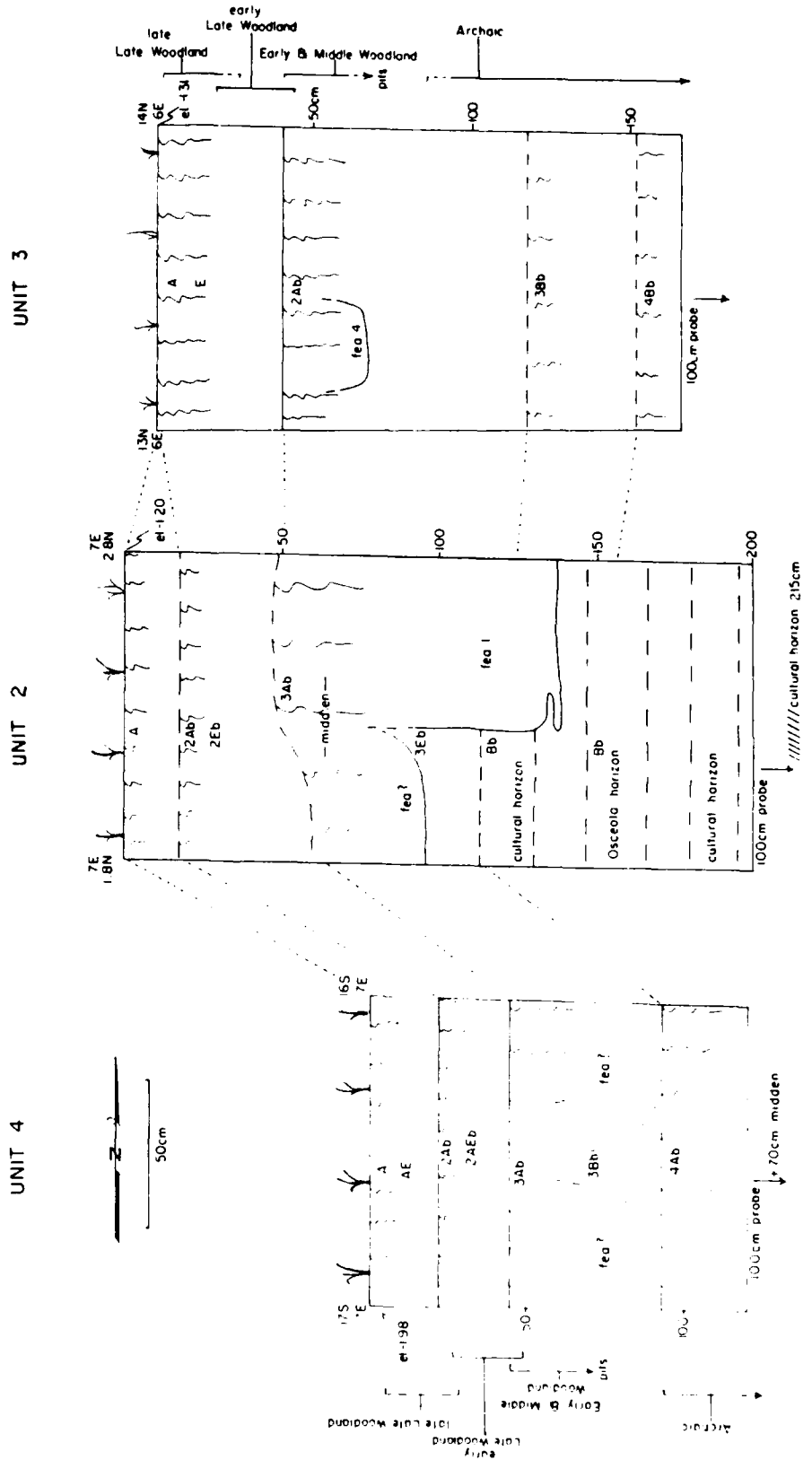

Figure 2.1  
Sand Run West (13LA3)  
1986  
Contour 5m intervals

FIGURE 2.2  
 SAND RUN SLOUGH (13LA38)  
 TEST UNIT PROFILES (May 1986)



# FIGURE 2.3 BLOCK B STRATIGRAPHY 13LA38

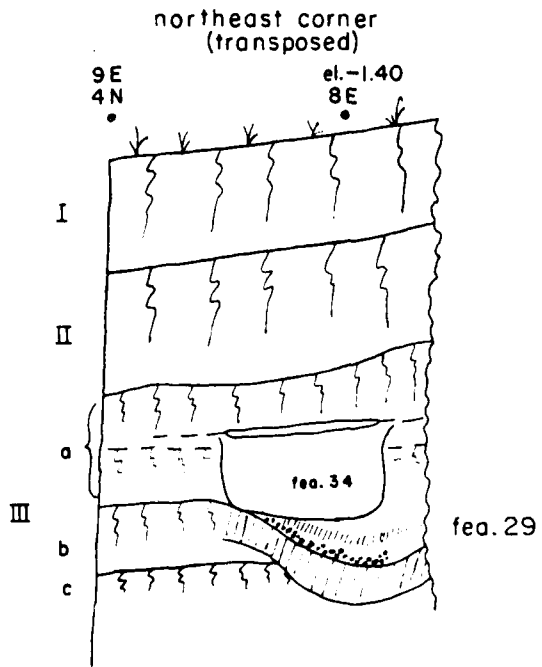
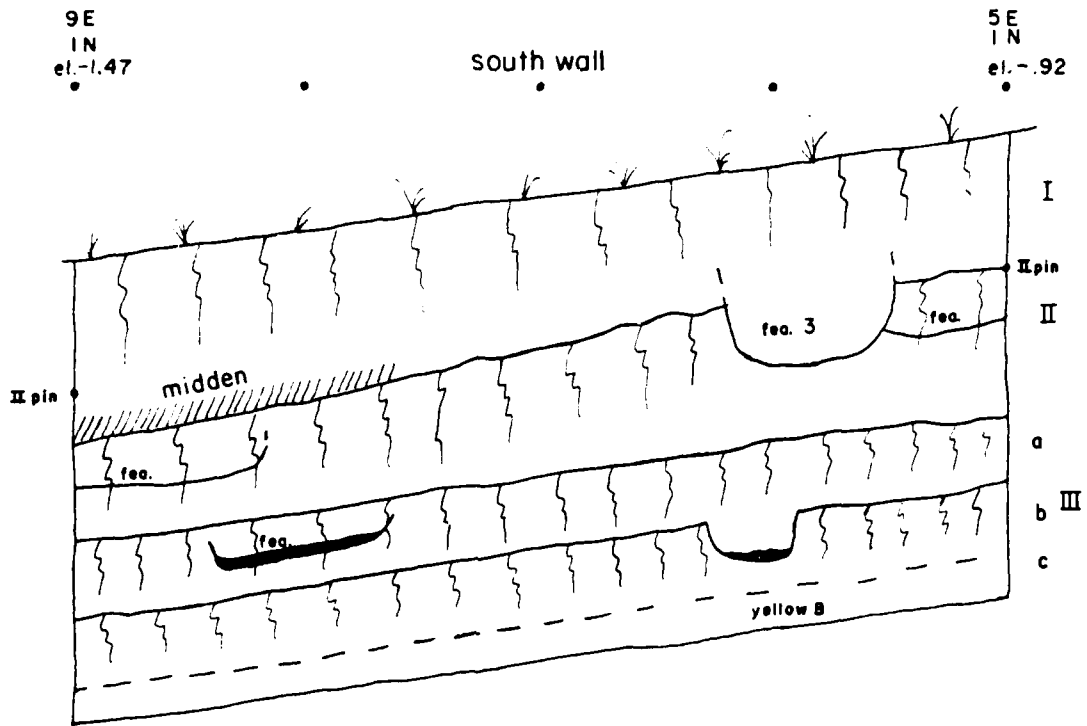
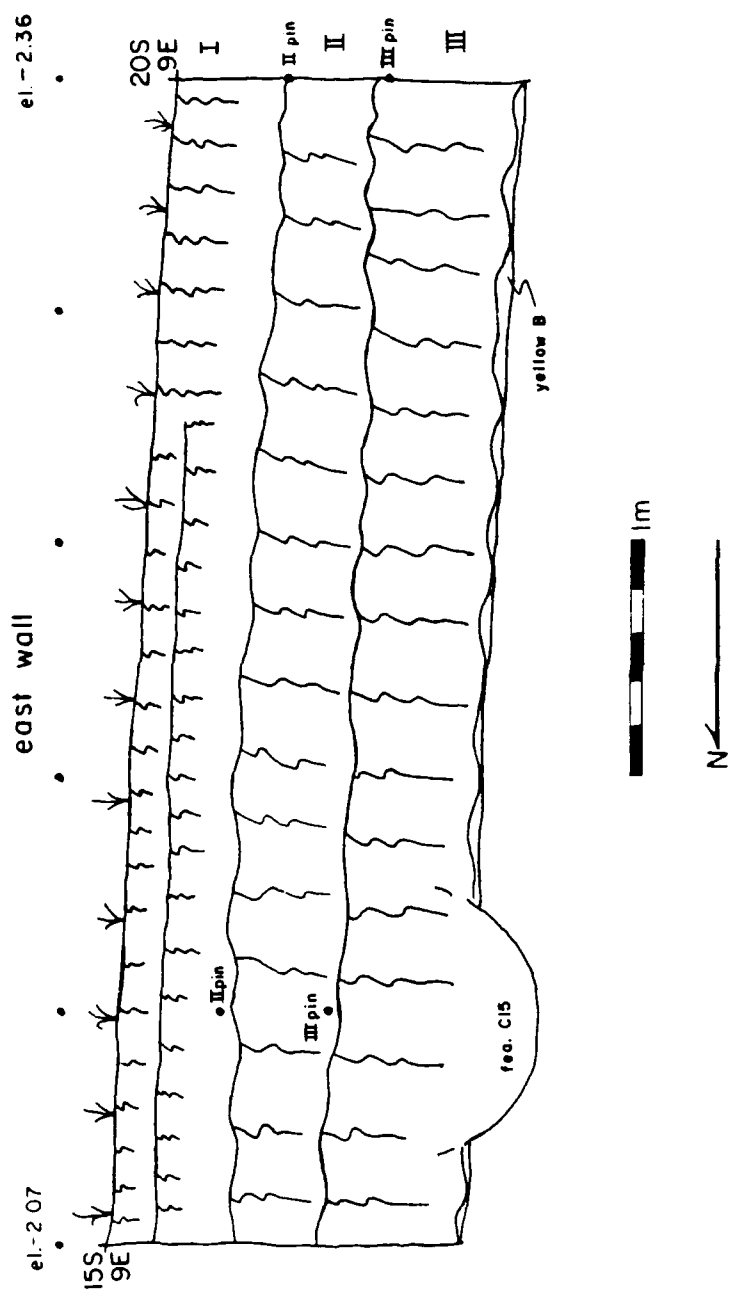

FIGURE 2.4: BLOCK C STRATIGRAPHY  
13LA38



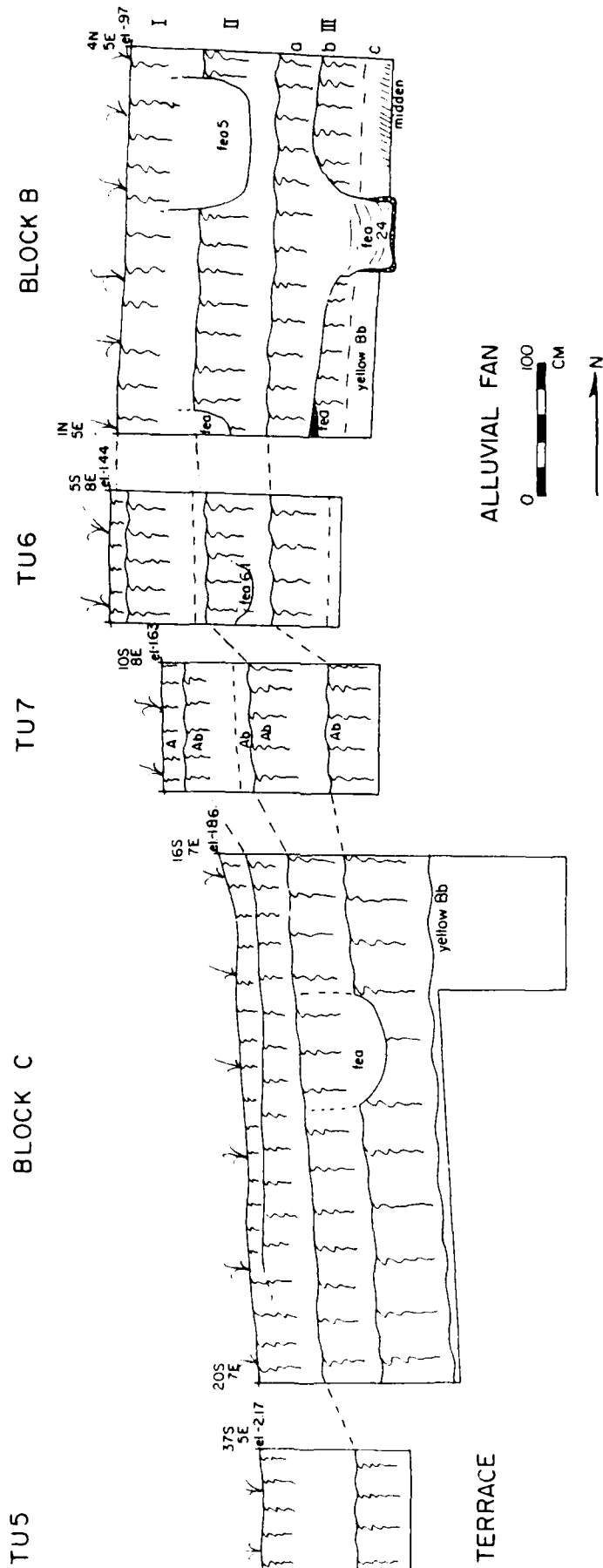
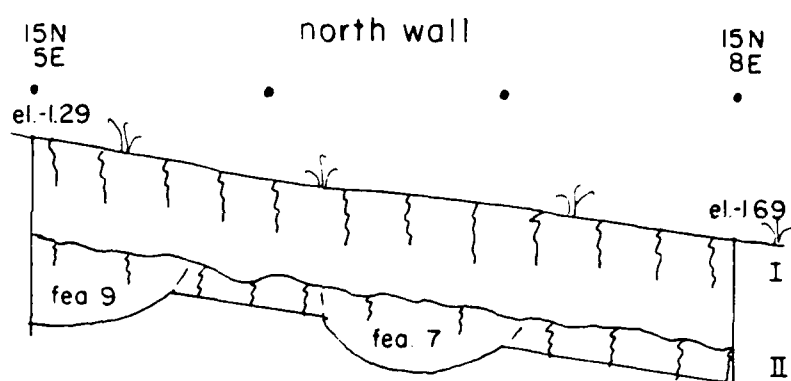

FIGURE 2.5: SAND RUN WEST N-S SECTION



FIGURE 2.6  
BLOCK A STRATIGRAPHY  
13LA38



1 m

W ←

Figure 2.7  
 13LA38  
 Block A Excavation  
 Strata I & II

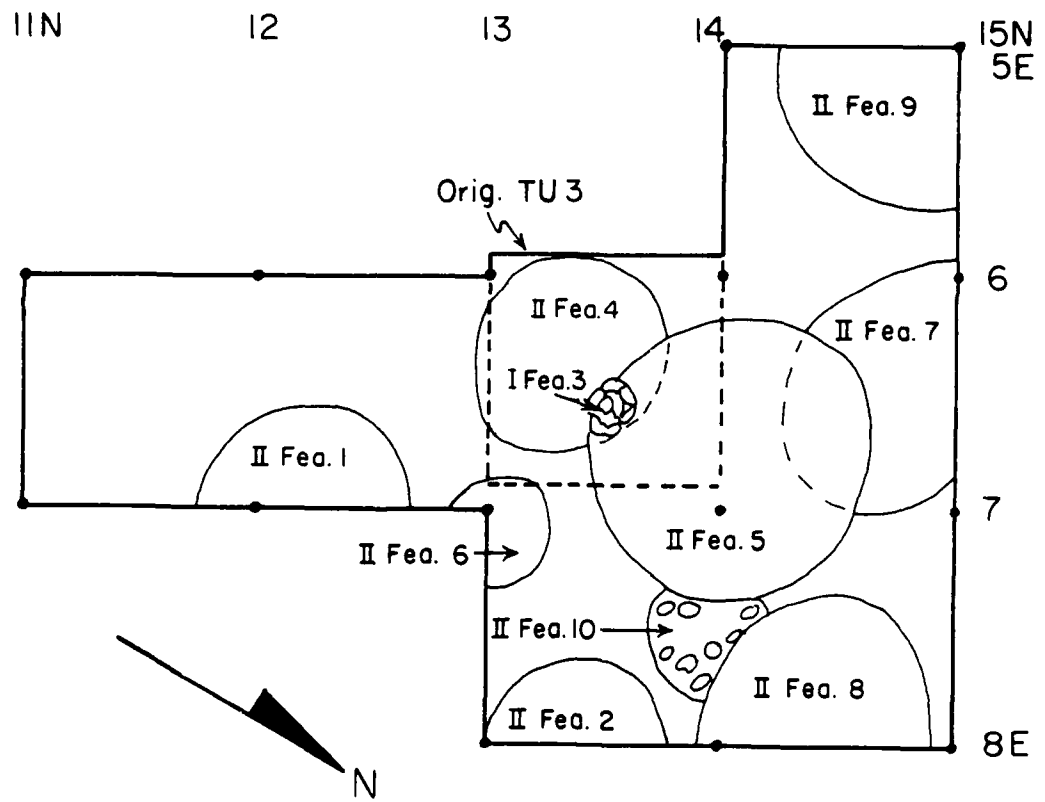

 Burned earth

 Carbon

0 100  
 CM.

# Figure 2.8 13LA38 Block A Features Middle Woodland Component

Fea 1 II-5  
Pit 11-12N6E

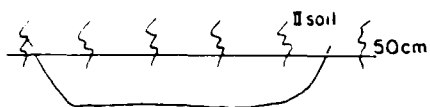

Fea 2 II-5  
Pit 13N7E



Fea 4 II-6  
Pit 13N6E

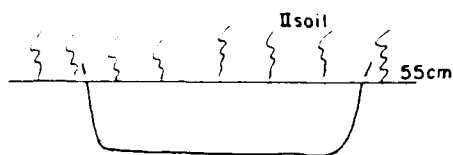

Fea 5 III-6  
Pit 13-14N6-7E

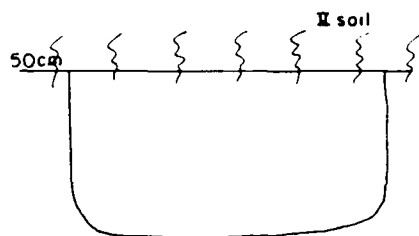

Fea 6 II-6  
Pit 13N7E

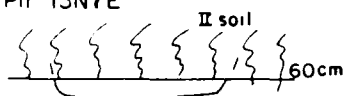

Fea 7 II-7  
Pit 14N6E

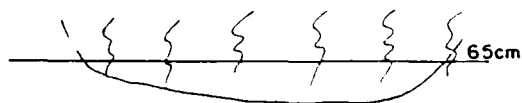

Fea 8 II-6  
Pit 14S7E

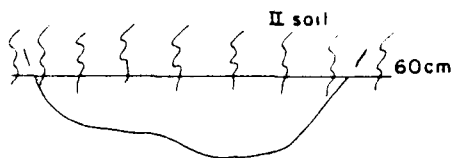

Fea 9 II-6  
Pit 14N5E

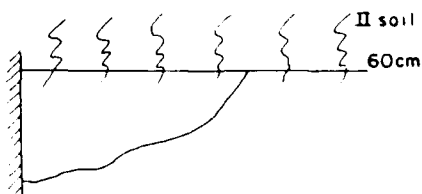

Fea 10 II-6  
Hearth 13-14N7E

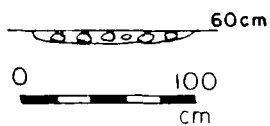

 Burned earth

 Carbon

 Soil

Figure 2.9  
 13LA38  
 Stratum II Features



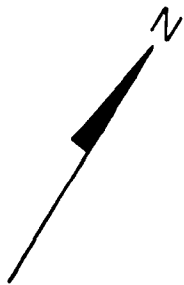
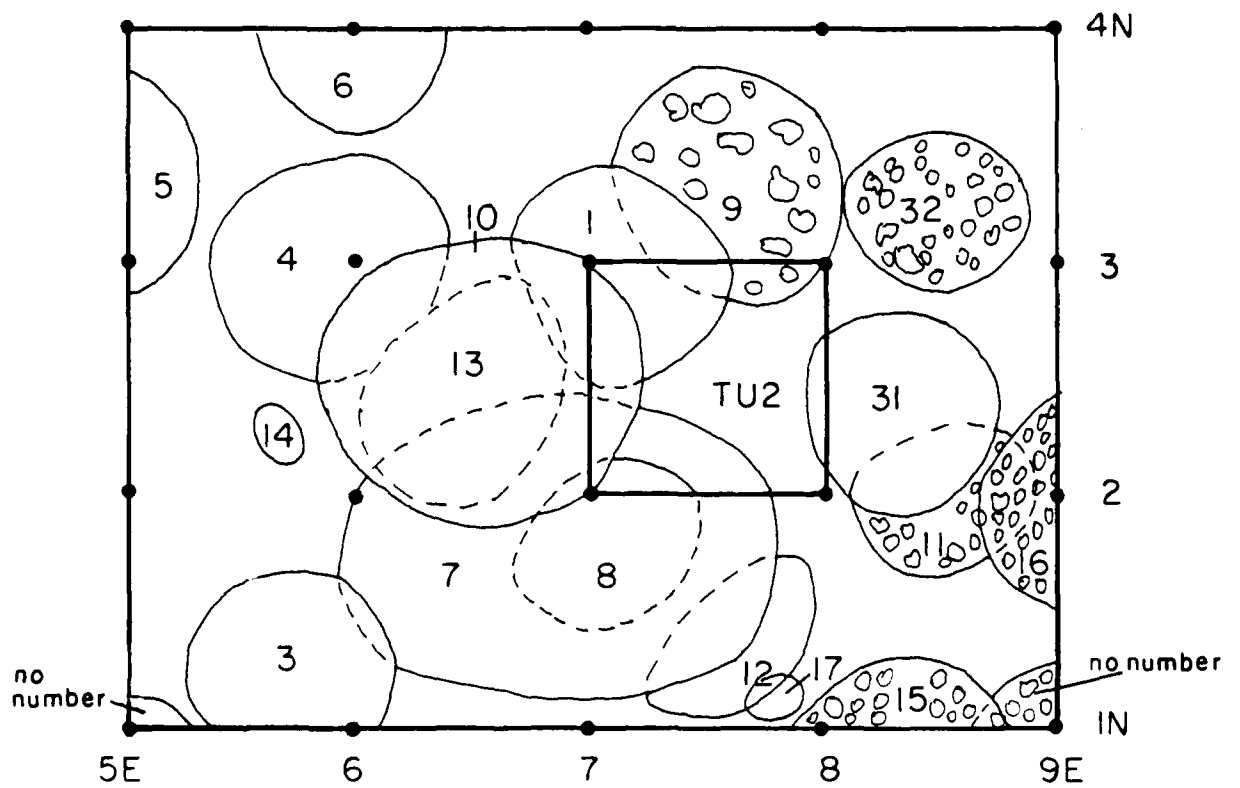

-  Burned earth
-  Carbon

Figure 2.10  
 13LA38  
 Block B Features  
 Middle Woodland Component

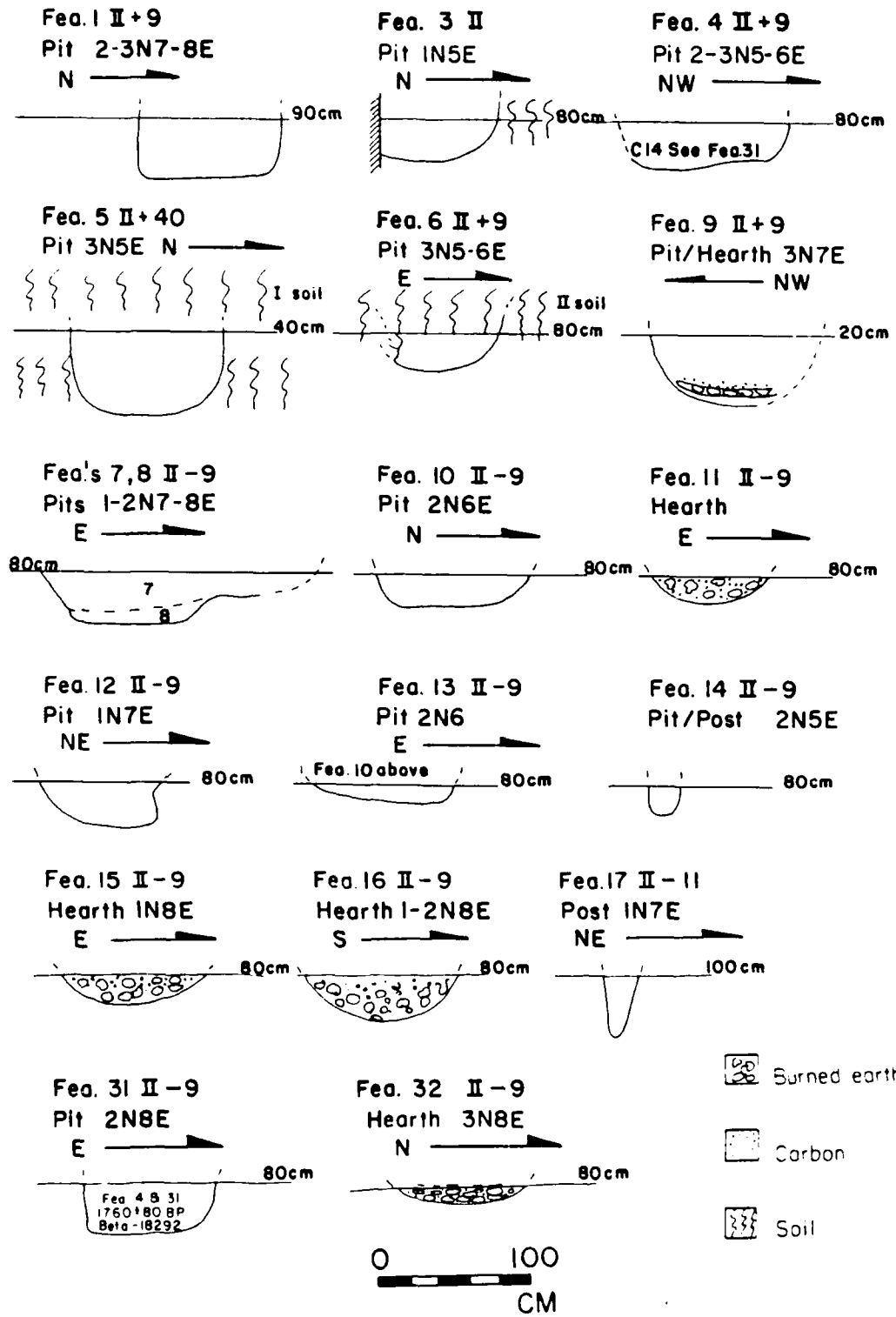

Figure 2.11  
 13LA38  
 Stratum IIIa Features & Artifacts

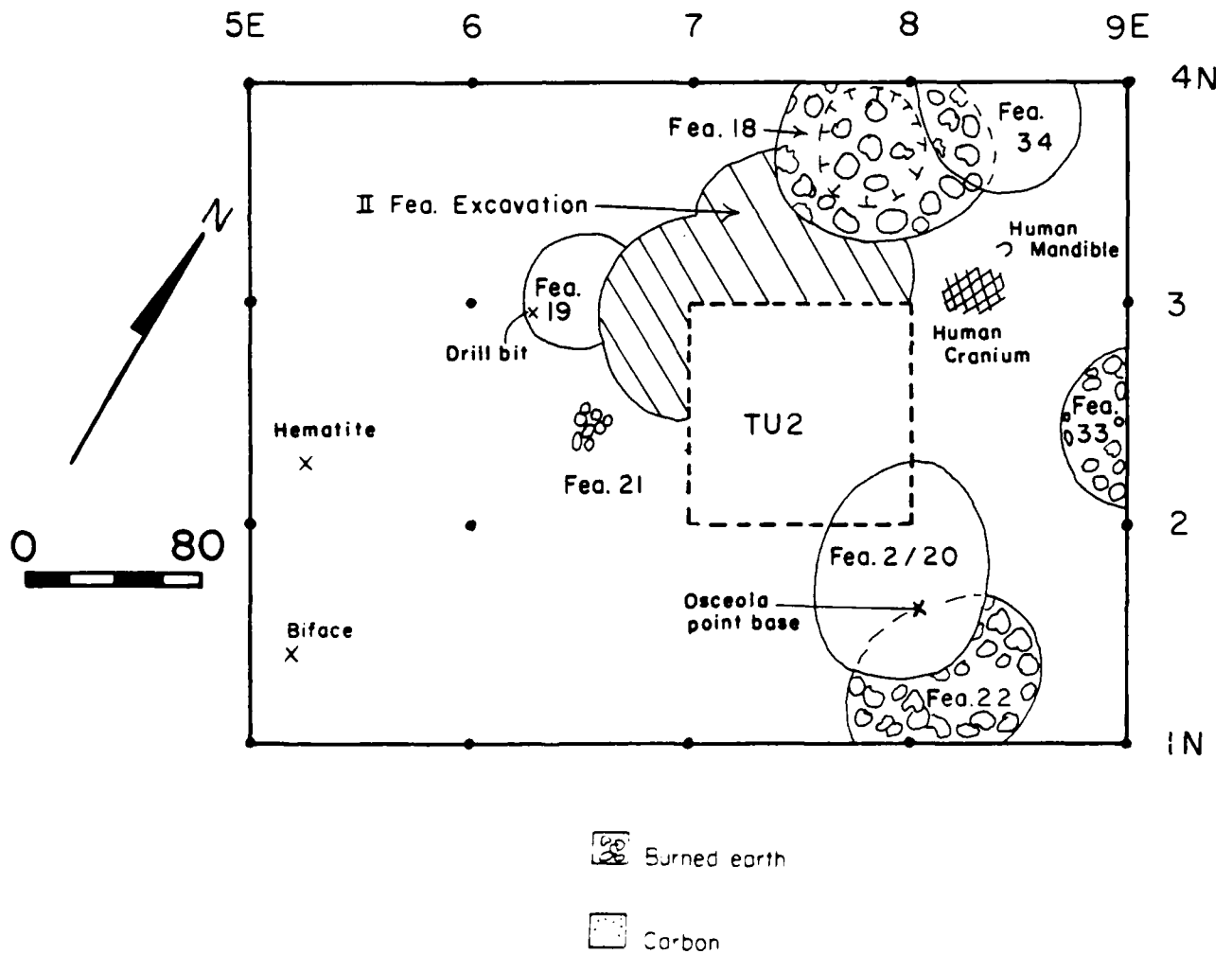

Figure 2.12  
13LA38  
Block B Features

Late Archaic Stratum IIIa Component

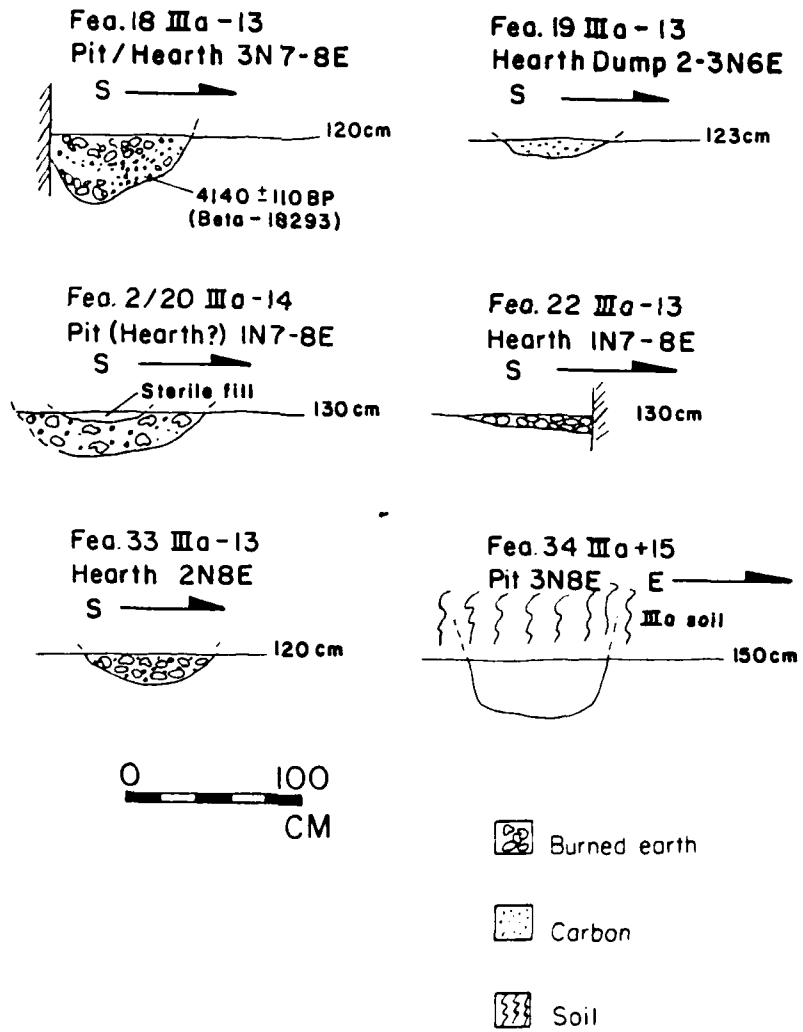

Figure 2.13  
 13LA38  
 Stratum IIIb Features & Artifacts

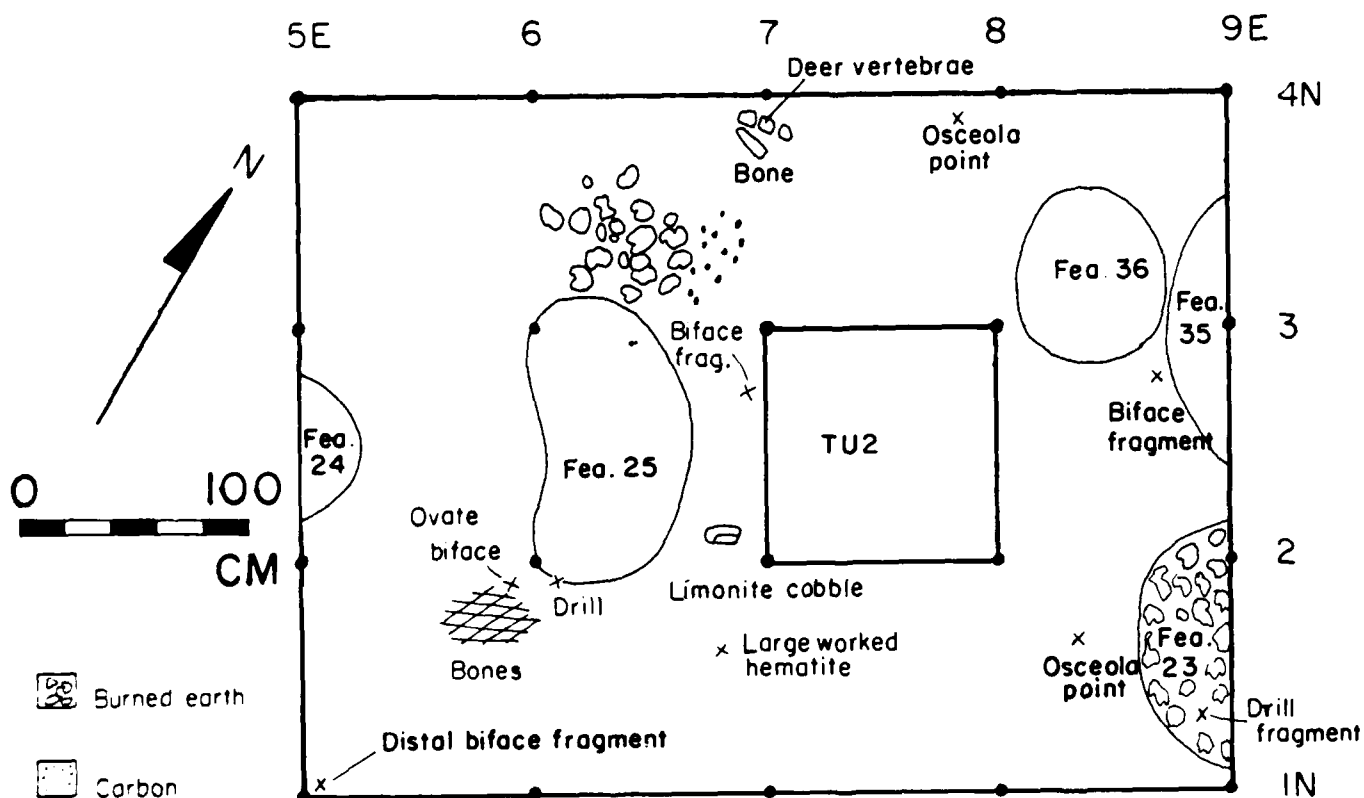



Figure 2.14  
 13LA38  
 Block B Features  
 Late Archaic Stratum IIIb Component

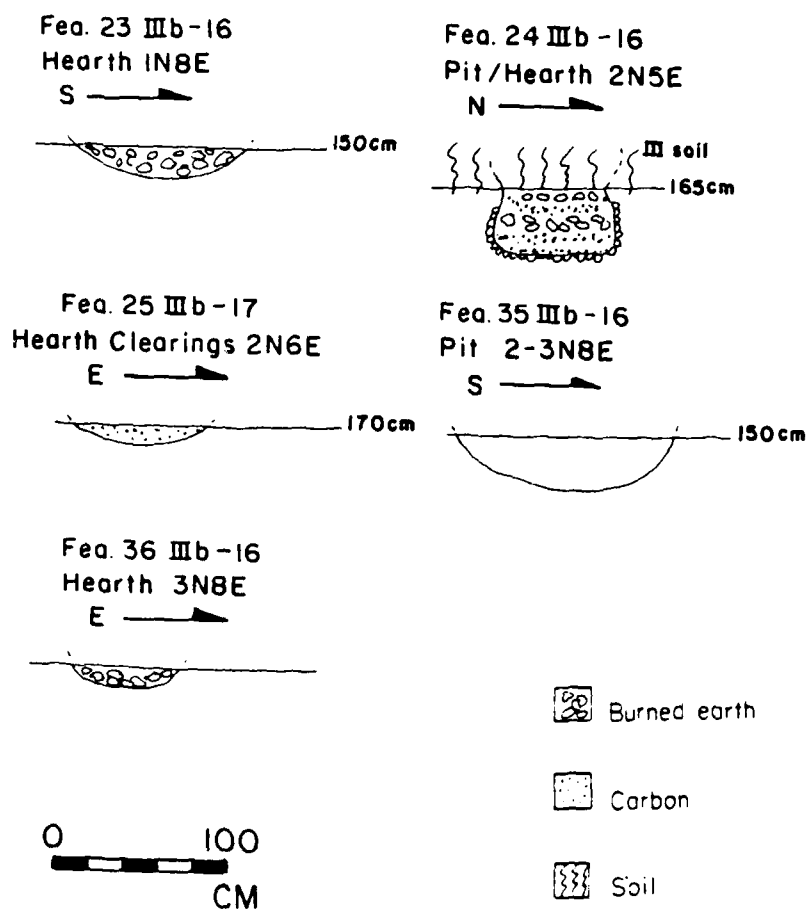

Figure 2.15  
 13LA38  
 Stratum IIIc Artifacts and Features

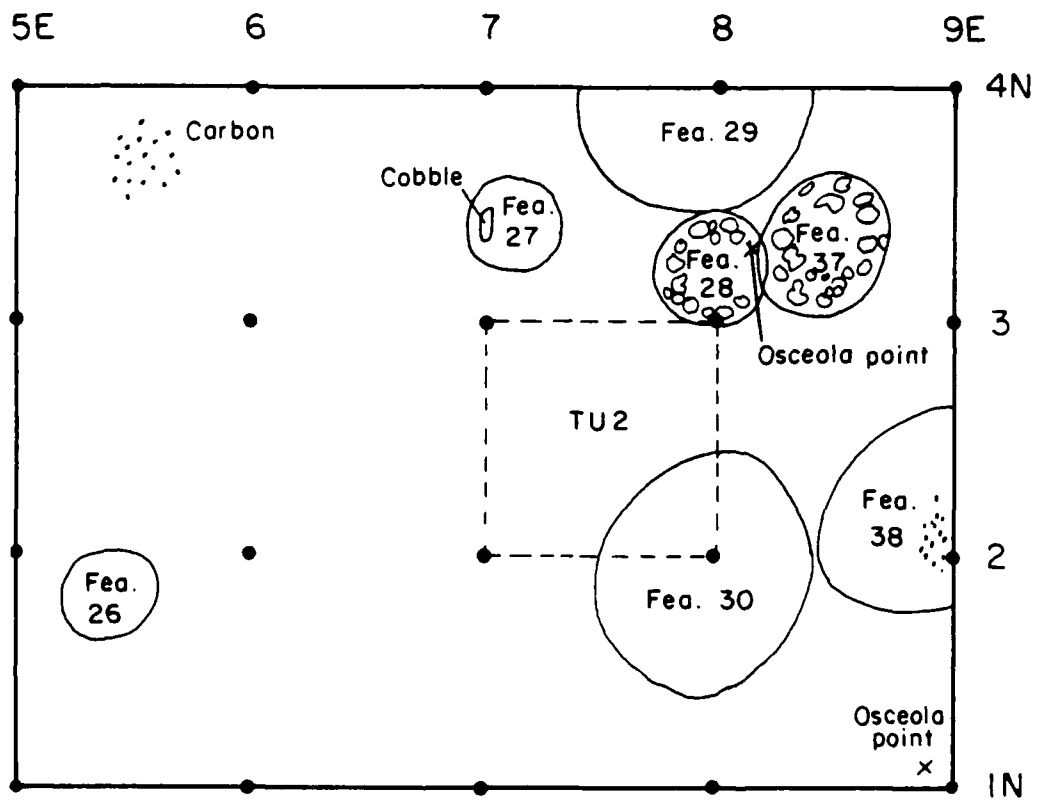

Figure 2.16  
 13LA38  
 Block B Features  
 Late Archaic Stratum IIIc Component

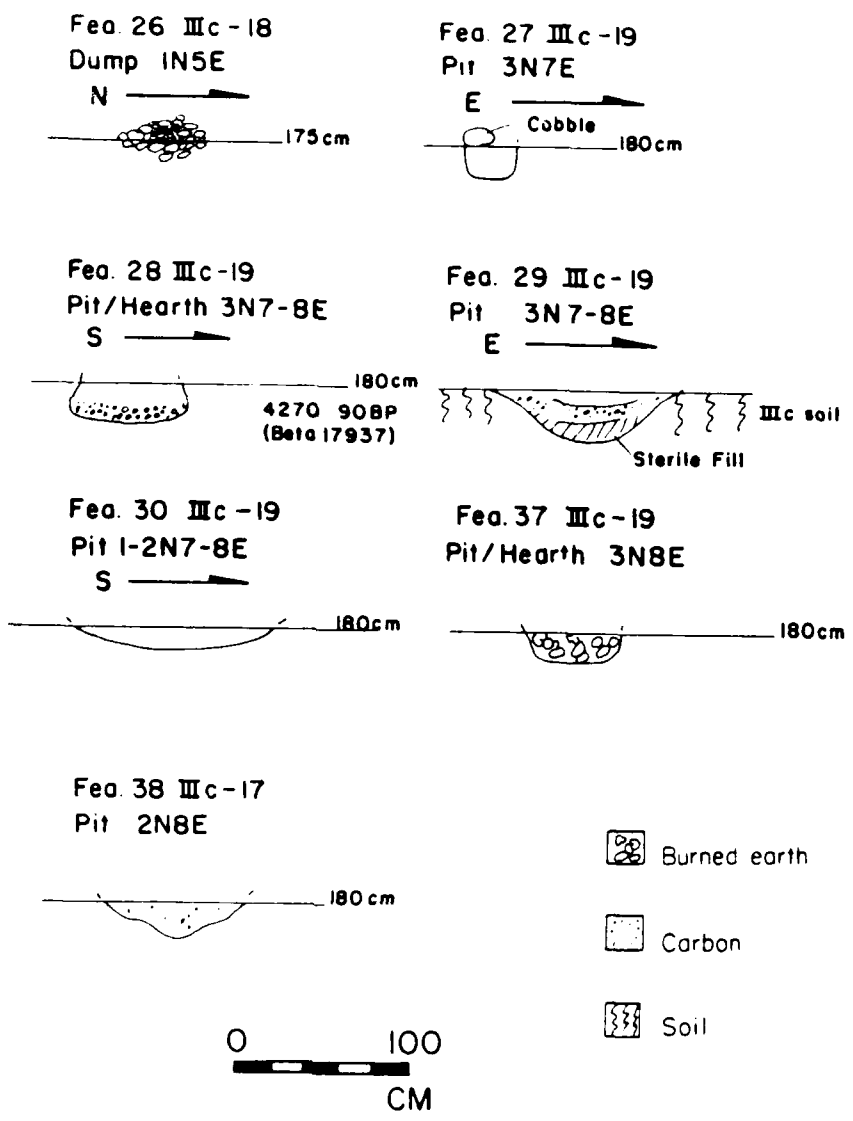

Figure 2.17  
 13LA38  
 Block C Excavations

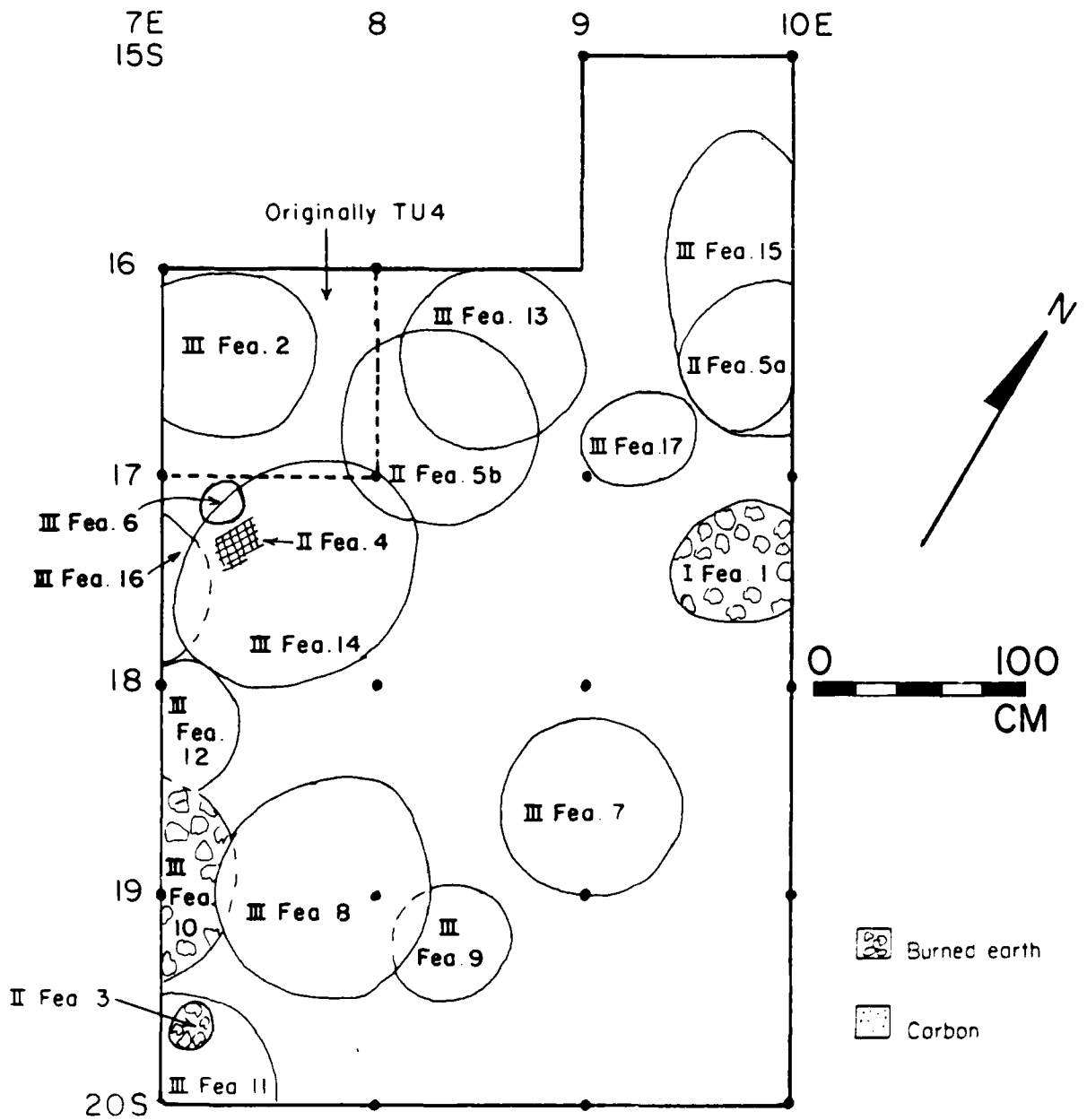
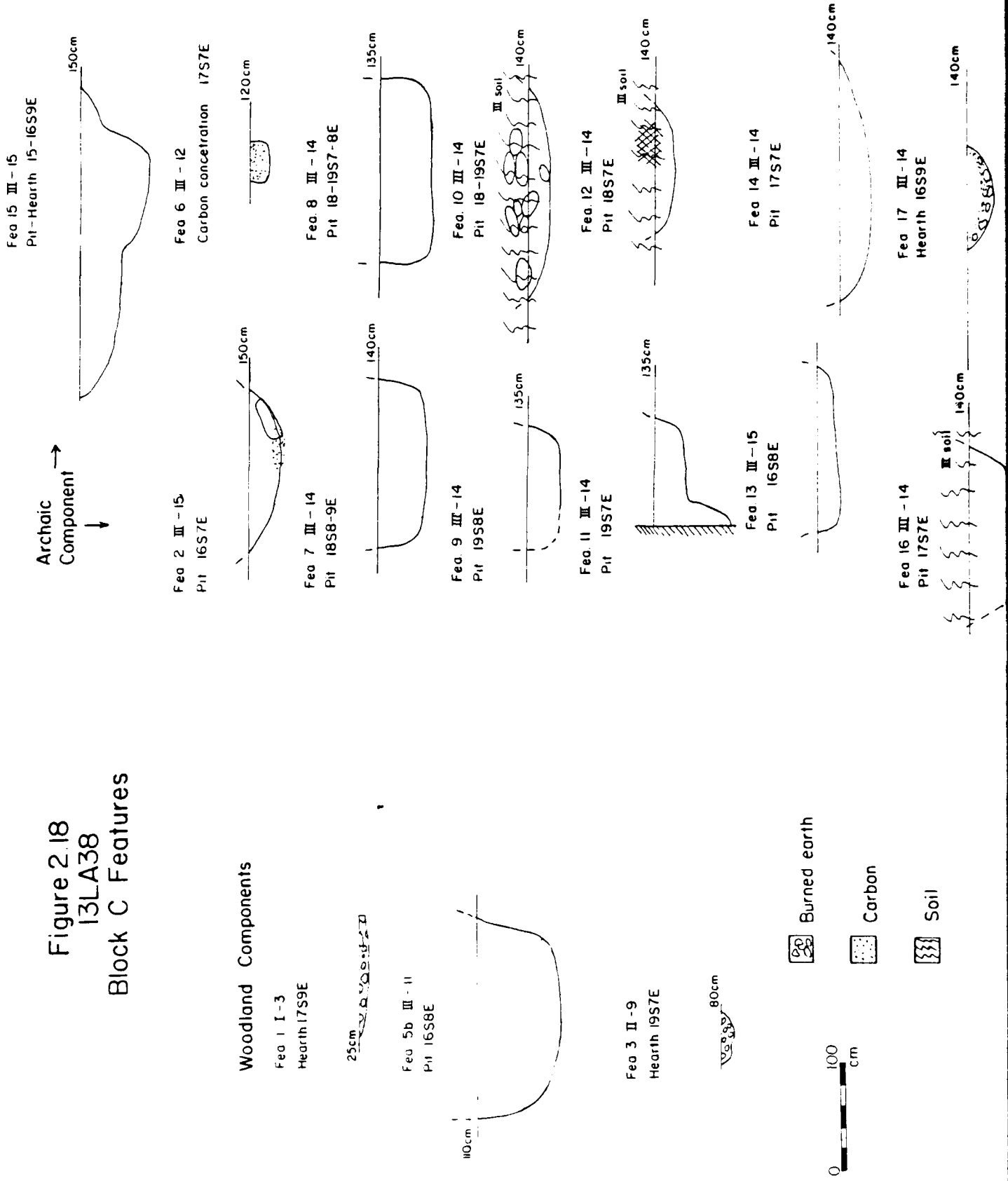
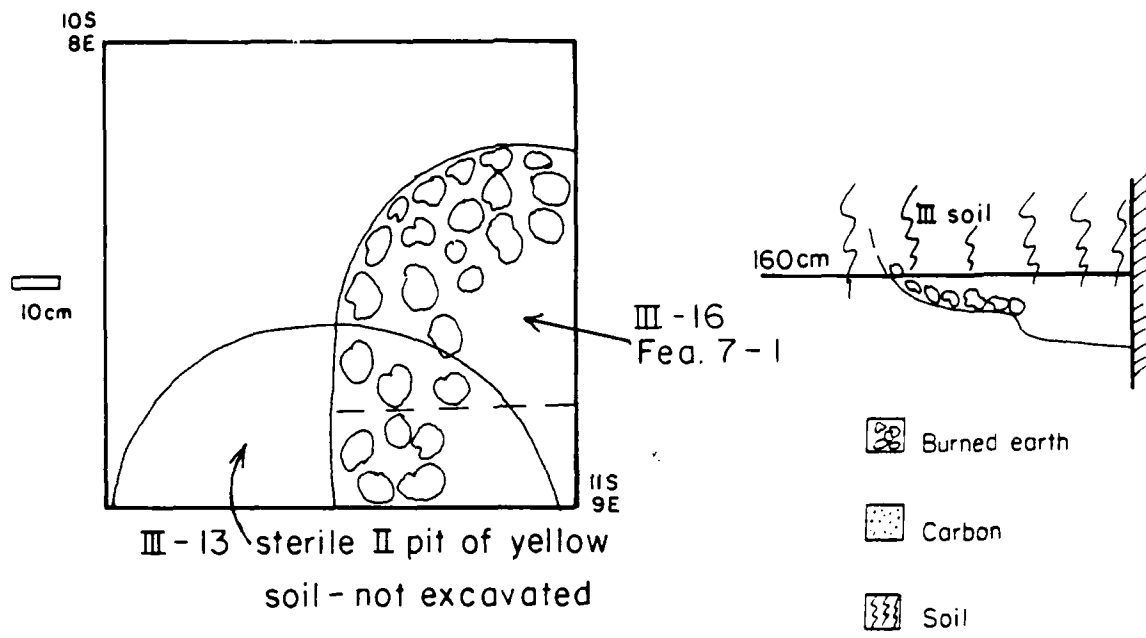

Figure 2.18  
13LA38  
Block C Features



# Figure 2.19 13LA38 Test Unit Features

## Test Unit 6



## Test Unit 7

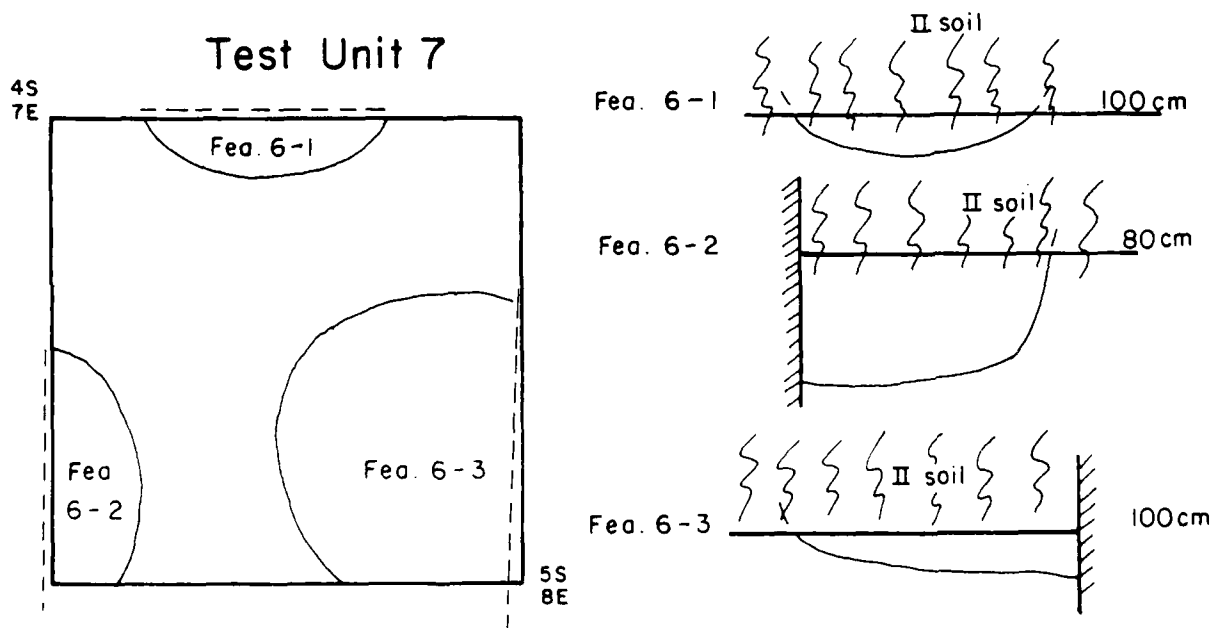

### III CERAMIC ANALYSIS

Materials made from fired clays are among the most important elements of the Sand Run site Woodland assemblage. In this material are expressed human technical and social relationships, and temporal changes in the ceramic assemblage reflect shifts in social affiliations and culture change. The Sand Run collections are composed of thousands of pieces of ceramic vessels, a few hundred fragments of fired clay and special items like pipes.

The analysis of Sand Run ceramics will follow traditional methodologies by first tabulating the collection, then describing all materials, and finally making regional correlations between ceramic types. The goal of the analysis is to fit the Sand Run ceramics into regional patterns that are already described in numerous publications. Specifically, a critical part of this overall goal will be the analysis of attributes on all diagnostic sherds from Sand Run. The writer has been gathering attributes from collections of ceramics across the state of Iowa for a decade, and the lists of attributes have been standardized. With the addition of the Sand Run material from the Mississippi River valley, it is now possible to span the prairies with comparisons of pottery types that represent the Woodland periods in culture history. Similar comparisons can also be made with published materials from the state of Illinois. Wide ranging comparisons will make it possible to answer the research questions posed in the project scope-of-work (see Chapter I and Appendix A).

#### The Ceramic Assemblage

The sites on Sand Run Slough have been surface collected for many years. Substantial collections of pottery, bone and lithics have accumulated in the hands of private collectors and at the Office of the State Archaeologist (OSA) in Iowa City. Pottery sherds in the possession of private collectors are jumbled among sites and have no reliable provenience. The collection at Iowa City is from several visits to the beachline at sites 13LA30 and 13LA38, which are constantly picked-over by local people. The diagnostic sherds from the OSA surface collections have been included in the present study to boost the numbers in the attribute analysis. Only body sherds from the 1986 excavation on 13LA38 have been analyzed.

Ceramic material analyzed herein numbers 2655 sherds, 852 burned clay lumps and 6 other ceramic items (Tables 3.1, 3.2). In the laboratory the ceramics were sorted into diagnostic (i.e. rims and decorated sherds) and non-diagnostic (i.e. body sherds, lumps, damaged) groups, the former being individually catalogued for attribute analysis. Non-diagnostic items were tabulated by

provenience, and those catalogue sheets are stored with the collections. All items in the following analyses are tabulated by levels within excavation blocks, not by each provenience, to simplify matters. Horizontal proveniences from the small excavation blocks at Sand Run probably are not significant. Explanations of the methods of measurement and analysis for this study are presented in Appendix C.

### Body Sherds

A total of 2177 undecorated body sherds was recovered from the Sand Run excavations (Tables 3.1, 3.2). Body sherds taken from mixed culture middens are impossible to sort precisely into types because their attributes overlap too much. However, combinations of surface treatments, temper types and relative thickness (cf. Braun 1983) make it possible to sort body sherds into groups that relate to known ceramic wares. This has been done in Table 3.2. Sherds in the "Liverpool Ware" column have reddish colors and deep, coarse cord roughening in soft, sandy pastes (see Figure 3.1). Sherds in the central columns have been sorted according to thickness and surface treatment. The 7.4mm measurement represents the division between the average thicknesses of Linn and Havana wares plus and minus one standard deviation (data from Benn 1978). The "Late Wood.(land) Corded Ware" column contains thin sherds (<7.4mm) with uniform, low-relief cord roughening completely covering the surface (see Figure 3.2).

The data in Table 3.2 show that ware distributions relate to the stratigraphy at 13LA38. Liverpool sherds occur only in Stratum II, the Early-Middle Woodland levels. Thicker sherds tend to be concentrated in Stratum II, while thinner sherds in the Late Woodland Corded sherds tend to be in Stratum I. There is substantial overlap between the thick (>7.4mm) and thin (<7.4mm) categories. A closer look shows that a very high proportion of the thin sherds have plain surfaces (76%), and many of these are burnished (14%). Baehr, Weaver and Linn wares, all thin-walled potteries of the late Middle Woodland and early Late Woodland periods, have high proportions of plain surfaces and conspicuous amounts of burnishing. Limestone temper, also a trait of Baehr and Pike wares, occurs only among the thin sherds. The thick walled potteries tend to be found in Havana ware, and the cord roughened and smoothed-over-cord roughened surface categories comprise 63% of these body sherds. Some Late woodland Corded sherds are grouped with the thick category, but the unique cord (fabric?) surface treatment distinguishes the Late Woodland sherds from Havana types in the thick sherd column.

From the results of this exercise with body sherds, it would seem that Woodland wares can be distinguished even in site collections with few or no diagnostic sherds. Additional correlations with grades of temper particles and the technologies



of surface finishes would add to the precision of typing body sherds.

### Diagnostic Pottery

The 13LA38/30 collections contained 429 rims and decorated sherds (Table 3.1). Attribute analysis of this material resulted in the definition of 11 ceramic wares, 27 types and three untyped groups (i.e. Baehr/Pike, miscellaneous miniature vessels, one carinated shoulder sherd). Definitions of wares and types follow common usage by midwestern archaeologists (see Griffin 1952). A pottery ware is a group types with similar vessel shapes, surface finishes, tempers and a common theme in decorative motifs. Wares supercede types, which are groups of vessels with the same combinations of decoration, surface finish and rim form. Variants also may distinguish some unusual, often minor combinations of traits within a type. All of the wares and types found at Sand Run have been described previously in published sources. Ware descriptions are presented in Appendix C.

#### Marion Thick

Five body sherds and one rim of this ware, the oldest pottery in the Midwest, came from 13LA38 (Figure 3.3). The sample is not large enough for statistical tabulation, so its attributes will be described. The one rim has a flattened lip and straight, vertical rim with no shoulder. Both vessel surfaces on all sherds and the one lip are cord/fabric roughened, although the impressions tend to be vague or superimposed. The fabric is coarse with very thick cords (one Z, one S twist) woven into a wavy surface. There is no decoration. Walls of the body sherds average 12.8mm thick (8.3-17.5mm range), and one orifice has a diameter of 190mm. The rim is 8.3mm thick (8.2mm lip), a size that fits the range of the later variant, Marion Thin. Pastes of the sherds are coarse and somewhat sandy with additions of very coarse igneous temper (chunks up to 8mm). In every respect the sherds from 13LA38 match the type definition (Griffin 1952) and recent descriptions of the ware (cf. Farnsworth and Emerson eds. 1986).

#### Liverpool Ware

This group consisted of 32 rims and 67 decorated sherds from 13LA30 and 13LA38 (Tables 3.3, 3.4). The ware was defined in collections from the Central Illinois River valley (Griffin 1952; Fowler 1955), and its basic definition has persisted into widespread use today. The ware is characterized by coarse pastes with massive structure, oxidized colors and large amounts of sand inclusions. Conoidal shaped vessels have little or no shoulder or rim curvature, but lips are often everted. Coarse, often oblique cord roughening made of S-cords covers the exterior

surface (Figure 3.1). Rectilinear decorations of zoned, parallel lines trailed in soft pastes typically cover the rim and shoulder of vessels. A row of embossing is usually set close to the lip. There are two types. A small proportion of rims of Liverpool Cordmarked are either undecorated or too small to evidence trailing on the rest of the vessel. Black Sand Incised is the majority type.

Liverpool Cordmarked (Table 3.3; Figure 3.4): The only decoration on these 17 rims occurs as a tool impression on the interior upper rim and lip of three specimens. Attributes that separate the Liverpool type from Havana ware include a high proportion of cord roughened or partially smoothed surfaces, even on lips (44%), thinned and everted lips, oblique cord roughening on the body, and a row of embossing set close to the lip.

Black Sand Incised (Table 3.4; Figure 3.5): Fifteen rims and 67 decorated sherds of this type came from 13LA30 and 13LA38. This assemblage conforms to the type and ware definition in every respect, with round and everted lips, straight in-sloping rims, cord roughened surfaces and thick walls predominating. Forty percent of the rims have CWS or fingernail impressions on the interior upper rim, but only one lip is tool decorated. Exterior decorations consist of zones of parallel horizontal or oblique trailed lines sometimes in combinations with columns of stabs. Zones of lines in herringbone, cross-hatch or nested patterns make up less than 10% of the sample. Thirty-seven percent of the upper rim zones are not decorated, but the occurrence of decorations in this zone on the rest of the sample does not mean that a separate upper rim zone was usually differentiated by the potters.

Liverpool Ware Discussion: Black Sand Incised is one of the most easily identified ceramic types of Woodland pottery. On the other hand, Liverpool Cordmarked proved to be the most difficult type to sort from the Sand Run collections because rims are small and nondescript. Much has been written about Liverpool ware, especially the Black Sand type and its affines (cf. Farnsworth and Emerson eds. 1986), but only recently have lists of attributes been presented in statistical form in published reports.

Tables 3.3 and 3.4 show comparisons between the Sand Run material and collections from the Central Illinois River valley (Munson 1986) and the Central Des Moines River valley (Benn and Rogers 1985). The tabular information confirms what researchers have stated in written descriptions for many years; that Black Sand (and Liverpool CM) ceramics from sites on the midwestern prairies are very similar. The Sand Run pottery is virtually the same as Munson's ceramic data. The pottery from the Central Des Moines River valley, called McBride Trailed, also is statistically very similar to Black Sand Incised. McBride Trailed paste is slightly less sandy and has large amounts of crushed rock temper. Following Stoltman (1986:123), there may be

justification for "splitters" to name a separate regional ware when there are differences in tempering agents. However, the microscopic attributes of temper and clay inclusions are difficult for every archaeologist to assess in every collection, and furthermore, archaeologists probably will never agree on what level of detail wares and types should be defined. In general, wares and types tend to be defined on a regional scale with new names being applied in "newly studied" regions. Thus, Fox Lake Trilled of northwestern Iowa and southwestern Minnesota (Hudak 1976; Benn 1982) and Crawford Trilled from the M.A.D. sites in central western Iowa (Benn 1983) are essentially regional varieties of Black Sand Incised (and probably contemporaries during the early Middle Woodland period).

In eastern Iowa there is another type to consider: Spring Hollow Incised (Logan 1976), now subsumed under Prairie ware (Stoltman 1986). Logan (1976:90) clearly differentiated between sherds similar to Black Sand Incised and others that contained crushed rock temper and a wider variety of decorations. Sherds viewed by this writer that Logan called Spring Hollow Incised have pastes more similar to Havana ware--i.e. coarse temper, blocky structure--and some of these vessels are quite crudely manufactured. These vessels appear to be typologically different from Black Sand Incised. The few trilled sherds from the FID site near Prairie du Chien (Benn 1978) fit with Black Sand Incised, as do the small collections of pottery from the Coralville Reservoir (Anderson 1971a) and Rock Run shelter (Alex 1968). Other unpublished materials from sites in interior eastern Iowa also viewed by the writer contain a variety of paste types and sometimes curious decorative combinations.

Stoltman has renamed Spring Hollow Incised as Prairie Incised to alleviate the problem of nomenclature--i.e. the association of an incised pottery type with Linn ware and the Spring Hollow nomen. This is a necessary housekeeping measure and a good idea. I am not optimistic that "splitting" the incised potteries into regional wares based on minor variations like temper will result in clear definitions of culture history. The earliest potteries on the prairies were by definition variable because they represented the initial full-scale application of this technology and because potters seem to have exploited the closest sources of raw material: i.e. alluvial soils at their habitation sites. The association of Havana and Black Sand sites and the influences of Havana decorative techniques in Black Sand assemblages would seem to be a more lucrative avenue of research (see INTERPRETATIONS, Chapter VIII).

#### Morton Ware

This ware is associated with the initial phase of the Havana tradition in the early Middle Woodland period (Griffin 1952). Sherds of this ware from mixed middens often occur in relatively small numbers, so types are difficult to recognize, sort and

describe. This is true of Morton type in the Sand Run collection (Table 3.5). While sites 13LA30 and 13LA38 yielded a total of nine rims and 26 decorated sherds of Sister Creeks Punctated, only two rims and six other sherds of the Morton/Fettie types were found. Morton ware consists of large, conoidal vessels with heavy walls (ave. rim thickness 8.3-8.8mm). Lips may be round or flattened, and rims usually are slightly curved and insloping or vertical. Interior surfaces are plain, while a high proportion of exterior surfaces are cord roughened or entirely covered by decoration. Decorations consist of a row of embossing below the lip and zones of punctating (Sister Creeks) or closely-spaced, parallel trailing (Morton/Fettie) on the exterior rim and body. The pastes of the Sand Run vessels tend to have massive structure because of large amounts of sand inclusions and medium-coarse sand temper. However, some vessels have less sand and a moderate amount of fine-medium (.25-2mm) crushed igneous rock temper, rendering their pastes like Havana ware. The Morton/Fettie vessels have more Havana-like pastes.

Sister Creeks Punctated (Table 3.5; Figure 3.6): The paste, form and surface finish of these vessels is very close to Black Sand Incised, the difference being primarily in decorations. A few punctated sherds may be parts of a larger incised design on Black Sand vessels. Otherwise, fewer lips are extruded, lips are flatter and there is more smoothing of the cord roughening in the Sister Creeks type. Sister Creeks vessels have designs composed of pinches, fingernail impressions, stabs, solid tools or hollow reeds in rows and columns. Impressions organized in vertical arrays on the exterior rim and body are the dominant motifs. Other decorations in other locations are rare.

Morton/Fettie Incised (Table 3.5; Figure 3.7): Morton and Fettie are separate pottery types in the literature (Griffin 1952; Munson 1986a), but the Sand Run sample is too small to give separate definitions in this analysis. Morton Incised has a cord roughened exterior surface, while Fettie surfaces are plain. Both have decorations of densely packed parallel trailed lines in bands and zones on the rim and body of vessels. Lines often occur in oblique or herringbone patterns with trailed borders. The small Sand Run collection has both plain and cord roughened sherds. Embossing is present on the three large specimens with the bosses being placed farther below the lip than in Liverpool ware. Stamps also occur on the interior upper rim.

Morton Ware Discussion: Griffin (1952:100-101) and Munson (1986a:284-287) state that the types in Morton ware show evidence of early Havana ware traits: e.g. less sandy pastes, more plain surfaces, lip flattening, rigorous design zonation. Morton ceramics are considered to represent part of the initial development of the Havana tradition in the Central Illinois River valley. This presumption seems to hold for parts of the Upper Mississippi River valley as well. A few Sister Creeks Punctated sherds have appeared in eastern Iowa (Logan 1976:90, Benn 1978; Tiffany 1986:163) and more go unrecognized in unpublished

collections. Morton and Fettle Incised sherds are less common in terms of real numbers (and because of their poor recognition among field archaeologists). These Morton ware potteries occur in rock shelter and open village sites with other Middle Woodland and Black Sand types.

A problem for making cultural interpretations from typologies appears when one moves farther west and north from east-central Iowa and the adjacent Mississippi River valley. Stoltman includes a Prairie Incised var. plain and a Prairie Linear Stamped within his Prairie phase ceramics of the Quad-State region (1986). These types are similar to Fettle Incised and Sister Creeks Punctated, respectively, and apparently were contemporaries. In the Central Des Moines River valley there is a relatively contemporary type, High Bridge Punctated, that is like the Sister Creeks type but has Havana-like paste (Benn and Rogers 1985). Likewise, the Sand Run collection contains Morton and Sister Creeks sherds that are difficult to separate from Black Sand Incised (cf. Munson 1986:285). It seems obvious that these typological inconsistencies are reflections of the actual evolution of the earlier Woodland ceramics. Munson, for instance (1986:298), suggests that people of the Black Sand tradition borrowed some notions of ceramic technology from the makers of early Havana potteries.

#### Havana Ware

This ware was defined at the 1951 conference at the Illinois State Museum. Definitions of the ware and its types have remained largely intact and applicable to a wide area since their initial publication (Griffin 1952; Fowler 1955). The Sand Run collections contain 105 examples of diagnostic Havana ceramics in nine types (Table 3.6). Havana ware is characterized by blocky pastes of coarse silts and clays tempered with moderate to heavy amounts of crushed igneous rock. Conoidal shaped vessels are large with bulky walls and slightly curved rims that are vertical or slightly flaring. Almost all vessels show intentional flattening and inward beveling of lips. Thus, lips tend to be thicker (Naples ave. 9.5mm) than rim walls (Naples ave. 8.5mm). More than 90% of exterior rim surfaces have been smoothed, although evidence for cord roughening occurs more frequently on body sherds (about 25%). Embossing is present on all upper rims in the Sand Run collection, and the row of bosses is positioned about one-third lower on the rim than in the type, Black Sand Incised. Decoration is rare on the interior rim surface, and none occurs on the lip. The exterior rim and body is divided into zones of decoration (often a narrow upper band and a wide lower zone), which usually consists of bands or fields of stamps demarcated by undecorated fields or trailed lines.

Naples Dentate Stamped (Table 3.6; Figure 3.8): This is the most common type in Havana ware with 22 rims and 38 other sherds in the Sand Run collection. Long, narrow dentate stamps are grouped

in columns, bands, fields or in continuous rows around the vessel for the main body of decorations. Complex motifs such as zigzag bands and alternating fields of oblique stamps are less common. The upper rim band often has a simpler vertical or oblique stamp. Three-quarters of the decorations are placed on plain surfaces, the others being superimposed on cord roughened or partially smoothed (SCLR) surfaces. The Naples type has been recovered from rock shelters in central-eastern Iowa (e.g. Levsen; Logan 1976), and it occurs in open sites in the Iowa and Cedar River valleys (e.g. Weichman and Iandarich 1974). Levsen Stamped, a late Middle woodland type in Linn ware (Logan 1976; Benn 1978; Stoltman 1979), has the same distribution as the Naples type in eastern Iowa and the Quad-State region. Naples Dentate Stamped is distinguished from Levsen Stamped by these characters: thicker flattened lips, bulkier walls, embossing and bolder dentate teeth in Naples; thinned rounded lips, hard thin walls, punctating and finer dentate teeth in Levsen (Benn 1978). In the central Des Moines River valley there is a comparable and contemporary type, High Bridge Stamped (Benn and Rogers 1985), which has notably less lip flattening and bevelling and slightly finer dentate teeth.

Havana Cordwrapped Stick (Table 3.6; Figure 3.9): This type name has been changed to distinguish it from a variety of Naples Stamped (Griffin 1952; Loy 1968). There are three rims and six other sherds in the collection. The characteristics of the Naples type also apply to Havana CWS, except that a cord-wrapped dowel was employed as the decorative implement. The dowel was wide, and cords were thicker than similar stamps in Linn ware (see Benn 1978).

Havana Incised (Table 3.6; Figure 3.10): Only a small sample of 5 sherds was recovered from Sand Run. This type has been recognized more recently than other Havana types (Loy 1968). The Sand Run sherds have parallel or cross-hatched lines trailed over plain surfaces, and in two cases a dentate stamp or slash has been alternated with the line. The lines are relatively fine--less average width than those in Hopewell and Baehr wares.

Havana Zoned Dentate (Table 3.6; Figure 3.10): Sixteen sherds from Sand Run have plain surfaces with decorations composed of wide (ave. 3.6mm) lines carefully trailed to form curved and intersecting bands. Bands between lines may be plain or filled with parallel dentate stamps. Vessels and decorations in this type were more carefully executed than other Havana types.

Havana Cordmarked (Table 3.6; Figure 3.9): Three rims have no exterior decoration and belong to this category by "default". The rims do have cord-wrapped stick stamps on the interior upper rim, and one is embossed. Considering the proliferation of decoration in all Havana pottery types, it is doubtful that even these few rims each represent an undecorated vessel.

Havana Plain (Table 3.6; Figure 3.9): Four rims and one upper rim without a lip have no decoration and plain surfaces. The four rims are too small to reveal if the lower rims and bodies were undecorated, but the remaining neck sherd is plain above and below a row of bosses as if it were from an undecorated vessel.

Hummel Stamped (Table 3.6; Figure 3.10): One rim and three other sherds have curved dentate stamps that are about 20mm long (see Loy 1968). Otherwise, the stamped decoration is the same as Naples Dentate Stamped.

Havana ware Discussion: Traits associated with Havana ware are widespread in the Eastern Woodlands and mid-continental prairies (cf. Griffin et al. 1970; Brose and Greber eds. 1979). Even Havana-like pastes are recognized in many regions, presumably because one pottery technology spread widely during the Middle Woodland period. For decades there has been speculation among archaeologists about whether certain potteries from interior eastern Iowa belong to the Havana tradition (e.g. "Amana Havana"; Tiffany 1986:160). The issue of whether a particular assemblage is part of Havana ware or a regional variant requiring different nomenclature can only be resolved by attribute analysis. Once the attributes are acquired, the comparison with Havana ware should be made at three levels: attributes, types, and chronological sequence of types. Strong similarities must be present at all three levels to fulfill the definition of Havana ware.

First, combinations of attributes that are characteristic of Havana ware should be present. Foremost among these is the flat, bevelled lip--a trait Griffin emphasizes (1966:613). Also important are high proportions of plain surfaces, embossing and elaborate zoned decorations with bold stamping and trailing. A good example of an equivocating application of attributes is to be found in Logan's (1976:92-93) description of Naples Stamped and other Havana potteries from sites such as the Levsen shelter. His Naples type includes several vessels with round lips, and tabulation of other attributes was not done for comparison. This writer has seen the Levsen collection, and Naples Dentate rims with flat lips are present. However, the entire collection from rock shelters numbers 104 sherds by Logan's count, and some of these rims deviate from the type definition. Havana ware with a complete array of attributes has been recognized in the Quad-State region, specifically at the FID site (Benn 1978) and in descriptions of Wisconsin material by Stoltman (1979). Farther west in the central Des Moines River valley the attributes of High Bridge ware have been shown to be different from Havana ware because of the low incidence of bevelled lips, ovoid stamping, elaborate zonation of stamps and trailed lines (Benn and Rogers 1985:46). Downriver in the Red Rock Reservoir, Roper (1986:179) has compared the local Middle Woodland stamped pottery with High Bridge Stamped and found her's to have a higher incidence of bevelled lips. She indicates examples of the Naples Stamped type probably are present. No other ceramic collections

from eastern Iowa sites have been subjected to attribute analysis.

The second comparison with Havana ware should be made with the combination of types in the assemblage. This information is tabulated in Table 3.7 for Illinois River valley sites and for the three Iowa collections where attributes have been analyzed. Notice that the four Illinois valley sites, Sand Run and FID yielded a variety of types representing several kinds of stamped, zoned and trailed designs. If body sherds were removed from the Illinois site counts, cord roughened and plain rims would be a much smaller proportion of the assemblage. By contrast, the Des Moines valley collections contain a paucity of stamped types and many more cord roughened, plain and trailed sherds (cf. Benn and Rogers 1985; Roper 1986:179). If tabulated, a similar limited range of types would be found in the rock shelter collections analyzed by Logan, with the Naples, Hummel/Neteler, and Cordmarked types being present. The issue of how many Havana types are present still exists for other unstudied manifestations like the "Amana Havana" and potteries from Middle Woodland villages in the lower Iowa, Cedar, Skunk and Des Moines River valleys.

The third comparison with Havana ware involves identifying the sequence of pottery types. Havana is a tradition that spanned a time period when pottery types evolved (cf. Griffin 1952; Munson 1986a:290). Fettle Incised and Sister Creeks Punctated were made early, followed by the wide range of stamped and zoned types, and finished with baehr and types with much less decoration. It is, basically, good methodology to recognize most of this evolutionary sequence of pottery types in an assemblage before it can be placed within the Havana tradition. The Sand Run collection has a complete sequence. FID lacks some of the earlier types (e.g. Morton, Fettle), and the place of the later types is taken by Linn ware. No other sites in interior Iowa have been shown to contain a substantial part of the Havana pottery sequence.

The foregoing discussion is not intended to destroy the notion that the Havana tradition spread beyond the Mississippi valley into interior Iowa. That will have to be investigated in pottery collections from the major river valleys. The point has been made that the Hopewellian manifestation in the central Des Moines valley (i.e. Van Hynning Phase, Benn and Rogers 1985) is not part of the Havana tradition. Because all three criteria are at least partly fulfilled in the ceramics, there are Havana components along the Mississippi River in the Quad State region. No definite statements can be made (based on pottery alone) about eastern Iowa rock shelters being part of the Havana tradition. Rock shelters were seasonally occupied during irregular periods in the past. Only parts of whole assemblages may have been left at these sites, even if the pottery actually was left by Havana people.



## Baehr/Pike & Hopewell Wares

Hopewell ware (Griffin 1952; Fowler 1955) has sufficiently strict standards to be recognized in only five sherds from 13LA38. Baehr (Griffin 1952) and Pike (Struever 1960; Morgan 1985a) wares and types are too complex to completely segregate among the small sample of eight sherds from 13LA30 and 13LA38.

Hopewell ware (Table 3.8; Figure 3.11): This ware is uniformly thin (ave. rim thickness 4.4mm), smoothed and carefully finished. Sherds are dark gray throughout. Pastes consist of fine silts and clays tempered with very finely ground rock (4 limestone jars, one grit bowl). Paste structure is very fine blocky. Lips are smooth and rounded, and three rims are slightly s-shaped (channelled) and vertical to slightly insloping. Another rim is from an open-mouthed bowl with a rolled lip. Interior channelling has sharp edges and is carefully executed. Decorations of very fine rocker stamping, trailing and annular punctating are delicate, shallow and precisely positioned on the exterior rim and body. The rocker stamps have shallow arcs.

Baehr/Pike wares (Table 3.8; Figure 3.11): One rim and three decorated sherds have been isolated as Baehr ware, while two rims and two decorated sherds are grouped as Baehr/Pike-like. The Baehr sherds are more carefully manufactured, although the remaining four are untyped because they are smaller and less well preserved. All eight sherds have pastes of medium-coarse silts and clays tempered with moderate amounts of crushed rock (6 grit/igneous rock, one limestone, one limestone and grit). The rims have flat bevelled lips (n=2/3) and s-shaped curves due to broad channels. Vessel surfaces are plain. These sherds are thicker (rim ave. 5.8-7.7mm), and have medium blocky pastes. Variable colors range from reddish-brown to dark grays to light brown hues with smudging and firing clouds. Interior rim channels are broad with vague edges. Exterior upper rims have cross-hatched decoration above a row of punctates. Rim and body decorations consist of fine brushing, rocker stamps with a wide arc, dentate stamps and trailed lines, all executed carefully but not as delicately as Hopewell designs.

Hopewell and Baehr/Pike Discussion: Morgan's (1985a) evaluation of Pike and Baehr ceramics does not distinguish the two wares except in "extreme cases." Subjectively, Baehr appears to be more refined than Pike and retains more strictly the attributes of Hopewell ware decorative elements. I doubt that this topological issue is relevant in Iowa. The Sand Run Baehr/Pike sherds compare with Baehr ware from the Central Illinois River valley and were manufactured at Sand Run. They represent a Baehr ceramic horizon in the Mississippi River valley between Iowa and Illinois (cf. Benchley et al. 1979: Figure 37). The Baehr type probably penetrated interior Iowa, since a locally made sherd was recovered from the Young site on the Cedar River (Benn and Thompson 1977: Figure 2a). In the Quad-State region Baehr is replaced by a similar and very strong local ceramic tradition.

Linn ware, which includes types with thin walls, rocker stamping and rim channelling (Logan 1976; Benn 1978; Stoltman 1979). A few elements of Linn ware also appear in Madrid ware in the central Des Moines River valley (Benn and Rogers 1985).

Without petrographic analysis it is impossible to know that the Hopewell ware at Sand Run was locally manufactured. Since there are Hopewell mound centers on the Iowa side of the river, local manufacture of this fine ware is probable. Besides Sand Run, Hopewell sherds have turned up with Havana ware at the Wolf site (Straffin 1971) and at Gast Farm just north of Sand Run. Fine Baehr and Hopewell sherds from interior Iowa do not match with the local assemblages and probably represent trade vessels. A Hopewell Cross-Hatched rim came from 138N262 in the central Des Moines valley (Benn and Rogers 1985:Figure B.2), and a limestone tempered Baehr rim was found at the Young site on the Cedar River (Benn and Thompson 1977:Figure 2b). These rims came from non-Havana, Middle Woodland contexts and probably were imported vessels.

#### Weaver & Linn Wares

These wares of the early Late Woodland period are considered together because issues of their typologies overlap.

Weaver ware was defined in the central Illinois River valley (Griffin 1952; Fowler 1955; Wray and MacNeish 1961). There are 81 rims of Weaver ware from 13LA30 and 13LA38. Weaver pastes are composed of coarse silts and clays with moderate to large amounts of finely crushed igneous rock (.25-2mm) and some particles of coarser (up to 5mm) temper. Sherd walls have a fine blocky structure and pale brown to gray colors. Weaver pastes are denser and less crumbly than Havana ware. Except for a small number of cord roughened rims, exterior rim surfaces are smoothed plain. Body cord roughening or partially smoothed cord roughening is more common. About 10% of weaver sherds retain evidence of burnishing due to the practice of rubbing leather-hard vessel surfaces. Weaver vessels have constricted necks, leading to flaring upper rims and expanding shoulders. Lips tend to be round and thinned, and rim walls are thinner (ave. 5.5mm) than Havana ware. Embossing occurs close to the lip on cord roughened rims. Otherwise, decoration is limited to various stamps on the exterior upper rim zone.

The definition of Linn ware (Logan 1976; Benn 1978; Stoltman 1979) is similar to weaver. The technical attributes are the same except for a high incidence of rim channelling and flattened, bevelled lips in Linn ware (i.e. the Levsen type). Another major difference is that Linn ware has much more decoration, including elaborate dentate and cord-wrapped-stick stamping, punctate motifs, corded rim designs and rocker stamping. The Sand Run collection has only 14 sherds of Linn ware.

Weaver Cordmarked (Table 3.9; Figure 3.12): Site 13LA38 yielded only three rim sherds that have cord roughening up to the lip. All three have a row of embossing placed close to the lip.

Weaver Plain (Table 3.9; Figure 3.12): There are 78 rims from 13LA30 and 13LA38. Almost 30% of the rims are undecorated. On the remaining rims practically all of the decoration consists of cord-wrapped-stick or plain tool impressions on the exterior upper rim. These impressions are vertical or oblique (down to the left) and may be so deeply impressed that the lip and upper rim assume a scalloped form. Decorations on the lip and interior upper rim are very rare.

Levsen Dentate Stamped, Levsen Cord-Wrapped-Stick Stamped (Table 3.10; Figure 3.13): Levsen Dentate has three rims and two decorated sherds, while Levsen Cord-Wrapped-Stick has two rims and three sherds, all but one being from 13LA38. Both types have the same rim form--thin, bevelled lips and shallow channels. Mostly plain surfaces are superimposed by decorations of dentate or cord-wrapped stick stamps that define the two types. Decoration consists of a band of oblique stamps on the exterior upper rim and decorative zones of similar stamps on the lower rim and body. One rim has embossing, which is rare for Levsen pottery, while another has shallow punctates like the Beahr type.

Levsen Punctated (Figure 3.13): One rim sherd came from the surface of 13LA38. This specimen has a thin wall and very thin lip. A decoration of large reed punctates in rows/columns is impressed on the rim and shoulder.

Miscellaneous trailed sherds (Table 3.10; Figure 3.13): Four sherds from 13LA38 have Linn ware pastes, plain surfaces and one or more fine trailed lines. These are not Spring Hollow incised; otherwise, Linn ware does not (yet) have a type name for vessels with trailed decorations only, in the manner of Beahr ware.

Miscellaneous miniature vessels (Table 3.11): Eleven rim sherds from the 13LA38 excavation units represent small "pinch pot" vessels. Their pastes are uniformly blocky, buff colored (oxidized), and are not tempered (n=5) or contain sand and grit inclusions (n=6). Surfaces are plain, and decorations are applied haphazardly when present. Two upper rims have oblique lines and dentate stamps, and one vessel has a row of punctates. Two rims are embossed. These sherds were recovered from Middle and Late Woodland proveniences and could belong to Havana, Weaver and Linn wares.

Weaver & Linn Ware Discussion: Everyone working in the Upper Mississippi River valley has confronted the issue of differentiating between Linn ware's Spring Hollow Plain and Cordmarked and Weaver Plain and Cordmarked. The simplistic approach is to use the Spring Hollow name in Iowa and the Quad-State region and Weaver in Illinois (cf. Logan 1976; Stoltman 1979; Benchley et al. 1979). However, this creates a

dilemma for analyzing potteries taken from the floodplain of the Mississippi River (cf. Boszhardt and Overstreet 1963:Table 1). The Sand Run attribute analysis offers an opportunity to investigate this problem by bridging several other site analyses. This has been done in Table 3.12.

The comparison of sites in Illinois, Iowa and the Quad-State region in Table 3.12 should be viewed for the relative representation of plain, cord roughened and highly decorated types. Note that the Sand Run collection falls in line with the Illinois sites in having very high proportions of plain rims and few examples of cord roughened rims. Sand Run also has low percentages of the decorated Levsen types, and Illinois sites show none. The latter information is incorrect. A few examples of Levsen Stamped exist in collections from the Illinois side of the Mississippi River (for instance in the Bud Hansen collection, Moline, Illinois), but they have been overlooked probably as Havana ware. Also noteworthy is the similarity in stamp types that appear on Weaver rims from Illinois and Sand Run. Embossing occurs on Weaver Cordmarked, but it is rarely found in Linn ware. Taken as a complete assemblage, the Sand Run pottery fits the properties of Weaver ware with a few Linn ware sherds being a different element.

The Weaver assemblage contrasts with ceramics from FID and the Quad-State region, and Madrid ware from the central Des Moines River valley (Table 3.12). The latter assemblages contain much lower proportions of plain surfaced rims, larger amounts of cord roughened rims and many heavily decorated vessel types. Additionally, the cord decorated and rocker stamped Lane Farm types are in Linn ware with nothing comparable in Weaver ware.

Another factor in the typology issue is the chronology of types in Weaver and Linn wares. Levsen types precede the Lane Farm types in Linn ware, whereas there is no clear chronology for Weaver ware. Until chronological controls are available for comparison between the wares, the Linn and Weaver dichotomy should be maintained in its present form. Mississippi River site assemblages should be typed according to their compositions, viz. Table 3.12.

#### Late Late Woodland Wares

The 62 sherds from Sand Run sites 13LA30 and 13LA38 represent at least three wares and perhaps more. Presently, researchers face two problems in analyzing materials of this culture period. First, types and wares have not been fully defined and integrated into a regional system as earlier Woodland potteries. Secondly, collections of late Late Woodland ceramics usually consist of small, poorly preserved sherds, or the sherd number is small. The former is the case at Sand Run, where almost all sherds have weathered surfaces that prohibit complete analysis of the fiber impressions.

This analysis will not result in new or revised nomenclature for late Late Woodland ceramics. Such a chore will have to be done by a committee. I will offer some patterns that emerge from attribute analysis of corded ceramics across the Prairie Peninsula.

Cord Decorated Ware(s): Pastes of this ware are composed of coarse silts and clays tempered with moderate amounts of fine crushed rock and grit (.25-2mm) and variable amounts of coarser rock (up to 5mm). Wall structure is fine blocky to laminated, and colors have a definite reddish hue that ranges from yellowish to dark gray. Smudging and firing clouds are common. Splices where sections of vessel were joined are sometimes evident. Vessels have globular forms with expanding shoulders, constricted necks and curved (everted) rims. Sometimes there are sharp bends at the rim-shoulder juncture. Lips are slightly thinned and round, and orifices may be castellated and/or squared. Interior and lip surfaces are plain, and some exterior rims also are smoothed and plain. Exterior body surfaces and most rims are covered by low-relief cord/fabric roughening of two forms. One form is composed of large, soft, loosely-twisted cords which make a shallow impression in paste sometimes described as "simple stamping" (Figure 3.2a). The other form is a tightly twisted cord which makes a deeper, clearer impression in paste (Figure 3.2b). Decoration is confined to corded designs on the interior upper rim, lip and exterior rim, with occasional reed punctates or lip tool marks associated with the corded design. Corded wares have been described by many writers (Fowler 1955; Hurley 1975; Logan 1976; Benn 1980; Morgan 1985b).

Cord Roughened type (Table 3.13; Figure 3.14): Four rims from 13LA38 lack exterior rim decoration. Two rims have tool notches on the interior upper rim, and one has deep cord impressions on the lip that give a scalloped effect. This type is like Morgan's (1985b:269) "cordmarked group" and is analogous to Madison Plain from farther north (Hurley 1975; Benn 1978).

Cord Decorated type (Table 3.13; Figure 3.14): Sites 13LA30 and 13LA38 yielded a total of 16 rims with lips, 16 mid-rim sherds and 16 shoulder sherds. Exterior surface finishes consist of 80% cord roughened/decorated, 17% plain (or mostly smoothed-over), and 3% (n=1) brushed. Interior decoration of horizontal or vertical cord impressions occurs on almost 30% of the sample. Tool and cord impressions are found on about 60% of the lips. Exterior rim surfaces are usually decorated with parallel horizontal cord impressions bordered above by vertical cord impressions and below by a row of knots, cord twists, cord loops, hollow reed punctates or CWS stamps. Complex designs of oblique cord impressions comprise about 10% of the mid-rim design. In the decorations, 2-twisted cords far outnumber S-twisted, while 2-twisted cords and replied cords occur in almost equal numbers. Cord decorated potteries include Canton ware (Fowler 1955), Lane Cord Impressed (Logan 1976), Lane Farr Cord Impressed

(Ibid.), Madison Cord/Fabric Impressed (Baerreis 1953; Hurley 1975; Benn 1980) and Feye Cord Impressed (Kivett 1952).

Collared type: A small sherd from the 13LA38 excavation represents this category. The (plain) surfaced rim has a strip of paste added to the exterior upper rim, and a short twisted cord is impressed on the collar. The sherd is too small for additional analysis.

Plain ware (Table 3.13; Figure 3.15): Though the sample is small, a group of seven rim sherds from the surfaces of 13LA30 and 13LA38 clearly do not fit with Weaver or Linn wares. The paste of the rims is composed of coarse silts and clays tempered with moderate amounts of coarse crushed igneous rock (.5-4mm). Paste structure is fine blocky, and walls are dense and compact. Exterior colors range from buff to dark gray with firing clouds present. Core colors tend to be darker grays (reduced). Vessel forms are not entirely known. Shoulders probably are sharply expanding, and rims are curved and mostly flaring. Lips are round or slightly flattened and bevelled outward. Lip smoothing usually results in extruding of paste over the exterior rim wall. Interior surfaces are smooth and uniform. Exteriors are rough and plain, often retaining horizontal wiping marks. Decoration is restricted to tool impressed lips on two rims, and one of these has a (row?) of vertical tool slashes on the exterior lower rim. Potteries with plain surfaces and tooled lips include Minotts Plain (Logan 1976:105), Sepo Plain (Harn 1975:412), Saylor Plain (Theis 1979) and Hartley ware (Tiffany 1982a).

Carinated shoulder sherd: A single sharply curved shoulder sherd was recovered from the 13LA38 excavation. Its exterior surface is covered by low relief cord roughening ("simple stamping"). Some late Late Woodland vessels exhibit abruptly curved or carinated shoulder forms (e.g. Bauer Branch pottery; Green 1976).

Late Late Woodland Pottery Discussion: The best approach to dealing with ceramics of this period is a pan-regional perspective. Attribute analyses are available for comparison of collections across the Prairie Peninsula.

The attributes of cord decorated potteries in Table 3.14 are from collections in eastern, central and western Iowa. Among the notable trends in this data is exterior surface finish: it usually is cord roughening in Madison Fabric Impressed (FI) and the Sand Run pottery, while Lane Farm and Loseke wares have high proportions of plain surfaces (cf. Haas 1985 for Loseke ware). Lane Farm is the earliest ceramic type in Table 3.14 and belongs to Linn ware. The distribution of Loseke ware is in central and western Iowa. Thus, cord roughened surface treatment is seen to be sensitive in both chronological and geographic dimensions. The other notable trend occurs in the types of decorative cords: the majority of decorative cords in Madison FI and the Sand Run potteries are replied cords, while Loseke and Lane Farm ceramics have more plied cords. This is interpreted to mean that the

simpler cord industries are associated with the earliest pottery (i.e. Lane Farm) and with the western Loseke ware. The most complicated cord industry is found in Madison FI with conspicuous amounts of replied cords and grouped and countered cord decorations. The Sand Run pottery falls somewhere between these extremes of simple-to-complex cords. If Minotts Cord Impressed were added to Table 3.14, it would show high proportions of plain surfaces and plied cords, i.e. "late" traits (cf. Tiffany 1986:229-236; Benn 1980:52-72, 1978:224).

Moving beyond attribute analysis to whole assemblages, cord decorated potteries have been described from several sites in central western Illinois (Riggle 1981; Morgan 1985b; McGimsey and White 1985). These potteries are thin-walled with cord roughened (some "simple stamped") surfaces. One type is decorated with tool impressions on the lip and occasionally at the rim-shoulder juncture (Morgan's "cordmarked series"), while the other has parallel, single cord decorations on the rim (Morgan's "cord-impressed series"). Many of these vessels have castellated rims and squared orifices. At the Schroeder site, Riggle (1981) found the cordmarked type beneath the cord impressed type. Riggle also recognized the presence of these types in Iowa at the Jollyville Hill locality south of the Skunk River confluence with the Mississippi River. Morgan (1985b:273) distinguishes between thin-walled types and what he terms "coarser" cord impressed and castellated pottery in the Maples Mills/Canton series (Fowler 1955). Many of the ceramics from Sand Run fit comfortably with the thin-walled Illinois pottery seen by this writer (although Sand Run sherds are too small to have visible castellations), but the incidence of cord roughened rims is low at Sand Run. Such a rim was found on the surface of a nearby site (13LA261). Some cord roughened or decorated rim sherds from Sand Run also have walls thicker than 7mm (4 rims, 5 body sherds in Table 3.2). I suspect that the thick/thin wall dichotomy should be considered in conjunction with surface treatment to render this trait diagnostic.

The preceding Illinois and Sand Run ceramics compare favorably with Madison FI in body form, thin walls, the consistency of surface cord roughening and cord impressed decorations. Madison ware is different in having no squared or castellated rims, a small proportion of cord roughened vessels, few other decorative elements (e.g. tool) besides cord impressions, and in possessing the most complex combinations of decorative cord types. In short, Madison ware and the Illinois corded potteries are not the same ware but appear to be analogues. Lane Farm Cord Impressed precedes Madison ware in the Quad-State region, and recent radiocarbon dates show Madison ware was contemporary with the Illinois ceramic series from Schroeder, Deer Track and the other sites (cf. Morgan 1985b). Also contemporary with Madison ware was Loseke ware in the central and western portions of Iowa. Interior southeastern Iowa still is a vast unknown in terms of corded ceramics. This writer has seen a few sherds in the Keyes' Collection (State Historical Society,

Iowa City) that conform to attributes of the western Illinois potteries, but many more sherds in this collection are Minotts Cord Impressed.

Minotts Cord Impressed (Logan 1976:103) has high proportion of plain surfaces and decorations of plied or replied cords in simple arrays of parallel cords. Rim castellations occur with the most complex corded designs: e.g. nested triangles and chevrons. Rim walls are moderately thick (ca. 5-6mm; Tiffany 1986) for Late Woodland wares, and sherd colors tend toward buff (oxidized). Associated with the cord decorated rims are plain rims, sometimes with lip notches. The Minotts assemblage was dated 900±80 B.P.: 1050 A.D. (Beta-12688) at 13WS61 in the Iowa River drainage (Lensink ed. 1986:105). Pottery with similar attributes, particularly plain surface treatment and a post-800 A.D. chronology, includes Hartley and French Creek wares in northeastern Iowa (Tiffany 1982a) and Saylor ware from the central Des Moines River valley (Theis 1979).

The seven plain rims from Sand Run, the Group 1 rims from 13WS61 (Tiffany 1986:229), Minotts Plain (Logan 1976:105) and the plain pottery from the Walters site near Iowa City (Anderson 1971b) constitute a single type. Lip notching and extruded lips are significant attributes in the plain types. Together with the cord decorated and castellated type, this assemblage is what researchers have been calling Minotts pottery (ware) for more than two decades. An analogous ceramic series probably is present in Maples Mills/Canton ware in the Central Illinois River valley, just as the Hartley and French Creek wares exist in the Upper Iowa River valley of northeastern Iowa. I also point to similarities between Minotts and Great Oasis ceramics (e.g. plain surfaces, high rim form, decorative motifs) to the west, for they represent contemporary cultural horizons.

#### Other Ceramic Items

Pipes (Figure 3.16d,e,f): Three broken pieces of ceramic pipes were recovered from the Middle Woodland stratum II. Two contracting stem sections at least 14mm wide and more than 28mm long have 3.5mm diameter reed stem holes. The one stem from feature 4, an articulated dog that extended into the stratum III midden in Block C, has untempered paste. Another stem from level II-6 in Block A is grit tempered. The pipe bowl from pit feature 5b in Block C has a 33x46.5mm bowl with an 18.3mm diameter bowl orifice and 3mm diameter stem hole. The Havana-like paste is tempered with fine crushed igneous rock. The bowl is slightly expanding on the stem side, and its surface is smoothed close to burnishing. The mouthpiece stem extended from the lower corner of the bowl at a ca. 130 degree angle. Extending down from the bowl base at a slight angle was a thick (20.5mm) handle or platform. Perino (1973:83) describes this stem/handle pipe form as a late version of the Hopewell V-base pipe and further indicates that the nearly vertical base, like the Sand Run pipe,



is the latest variety of this pipe before the appearance of the elbow form.

Disk (Figure 3.16g): A fragment of a ceramic disk measuring at least 37mm in diameter and 16.7mm in thickness was found in level 4, Stratum I, Block C. The disk is perforated off-center. One flat face has two concentric rows of shallow punctates, and the other face has a single concentric row of irregular punctates. On the convex edge nearer the double-punctated face is another row of punctates. The object is tempered with moderate amounts of grit. Its function is unknown, but the positioning of punctations on the edge and faces resembles drilled holes on Hopewell stone ear spoons.

Figurine Head (Figure 3.16h): A 39mm tall and 28mm diameter human figurine head came from Stratum I, level 4 in Block C. The object is buff colored and tempered with large amounts of sand and at least one pebble. The head is oblong with no neck constriction. Its surface is smooth and featureless except for pinched nose and ears and a faint impression of one slanted eye. This figurine form is the "Casper the Ghost" variety usually associated with the late Middle Woodland period.

Shaped Items (Figure 3.16b): Four items, two from Stratum I and two from Stratum II, appear to be shaped from ceramic paste. Three have sand inclusions, and one is tempered with small amounts of crushed rock. One object has a reed hole. Two are cylindrical in shape (6mm diameter). The fourth is flattened and may be an arm or leg broken from a crude figurine.

Daub (Figure 3.16c): Two pieces from Stratum II and one from Stratum I were recovered from Block C. These are the only pieces of daub recovered from hundreds of burned clay lumps. The daub paste has sand inclusions. Grass and pole impressions are clearly evident.

Burned Clay Lumps (Figure 3.16a): A total of 852 pieces of burned clay were examined and tabulated (Table 3.2). Many small pieces were not recovered during the fieldwork. These objects range from rough, partially fired clay and clayey soil to lumps of ceramic clay that show evidence of kneading and forming. Most are finger-sized, but a few are palm-sized. Sand inclusions tend to be the only other materials in the pastes. Fired clay is not relegated to the ceramic bearing strata at Sand Run. Many lumps came from Stratum III in Block C, the Late Archaic component, where there was no pottery. Some fired lumps were the bi-products of ceramic manufacture, but others probably were produced incidentally in the hearth during normal domestic activities.

## Chronology & Culture Patterns In Ceramics

Ceramic relationships discussed in the preceding sections are connected to a cultural chronology in the next paragraphs. Some speculations about regional patterning are developed as well.

The ceramic stratigraphy from Sand Run (Table 3.15) has the look of the chronology known for three decades in the Midwest. Cord decorated potteries dominate the upper four levels. The peak for Weaver and Linn wares occurs below the bulge in the curve for cord decorated, and Weaver/Linn pottery also is deposited in features in Stratum II. Havana ware has the most extensive curve with its largest percentages in the lower half of Stratum II. Baehr ware conforms to the Havana curve and is largely below that for Weaver and Linn wares. Morton ware is concentrated with Havana in the lowest levels of Stratum II. Interestingly, the concentration of Liverpool sherds is not below that of Havana or Morton wares, raising speculation that the people who made Liverpool and Havana wares were contemporaries at Sand Run. On the other hand, the curve for Marion ware is far too high in the stratigraphy. Undoubtedly, Marion Thick sherds and some Liverpool ware have been displaced upward by extensive pit digging during the Middle Woodland period. Despite this anomaly in the lower levels of Stratum II, a full ordering of ceramic types characteristic of the Central Illinois River valley is present in Sand Run. There is no reason not to assume that the Illinois River ceramic chronology is applicable to the Three Rivers region of the Upper Mississippi River valley.

Marion Thick was manufactured mostly between 600 and 200 B.C. in the Midwest (Emerson 1986:629). The only Marion sites in Iowa occur along or very close to the Mississippi River trench: the Elephant site (13AM59)(Logan 1976:65-70) in northeastern Iowa; the Smith site (13LA2) and 13LA3 near Sand Run (Anderson 1971:3; Billeck 1986b). Collections from three unpublished sites on Lake Odessa a mile north of Sand Run also contain Marion-like sherds. Likewise, most of the Minnesota version, LaMoille Thick, has been found in the southeastern part of the state (Anfinson ed. 1979:117). All of these sites are not stratified and have yielded no dates. The most likely locations for future finds of Marion Thick will be the large interior river valleys of Eastern Iowa, where substantial Middle Woodland aged sites have yet to be investigated.

The Black Sand tradition has undergone major renovations with the announcement of Munson's (1982) twin-tradition model (i.e. Black Sand and Havana) and the publication of the Early Woodland Archeology volume (Farnsworth and Emerson eds. 1986). A current perception is that the Black Sand tradition developed by ca. 550 B.C. as the Cypress phase in the southern part of the Upper Mississippi River Basin, i.e. the vicinity of the confluence of the Mississippi, Missouri and Illinois rivers (Farnsworth 1986). The tradition moved north to the Central

Illinois River valley and to the southern edge of the Three Rivers region by ca. 400 B.C. Farnsworth and other writers in the Early Woodland Archeology volume (e.g. Stoltman 1986; Tiffany 1986) place the Black Sand tradition in interior eastern Iowa by ca. 100 B.C. and in the Quad-State region by the time of Christ. The implication is that the Havana tradition displaced or assimilated the Black Sand population. The northern and western reaches of the Upper Mississippi Basin apparently harbored the Black Sand tradition later in time as the Havana tradition blossomed to the east and south (Ibid.; Munson 1982; Farnsworth 1986:638), and elements of the Havana tradition appeared quite suddenly about A.D. 1 in interior Iowa and the Quad-State region.

Modelling in the last sentence seems to match the evidence from interior Iowa. For instance, in the central Des Moines valley a dichotomous settlement pattern between the Polk City phase (people making McBride ware) and the Van Hyning phase (people making High Bride ware) implies at least partial contemporaneity of the phases (Benn and Rogers 1985:44). But, there is a problem with applying the model in the Three Rivers region. The presence of Marion Thick, Morton ware and a full range of early and late Havana pottery types from sites in the Mississippi River valley are evidence for the local development of the Havana tradition beginning with the Late Morton/Caldwell phase (ca. 250-150B.C.; Munson 1986:292). According to the model, either 1) early Havana and Black Sand traditions were co-residents in the Three Rivers region, or 2) the Havana tradition in the Mississippi valley displaced Black Sand peoples to the interior. The presence of Prairie Incised and Havana pottery types in interior Iowa rock shelters supports the latter pattern (2). The ceramic stratigraphy from Sand Run can be taken as evidence that Black Sand and Havana populations occupied the site during the same time period (1).

Due to the mixed components at Sand Run and other Iowa sites, it is impossible to precisely define where and when the Havana tradition had its inception. We can compare the ceramic inventories from a few sites to grasp some notions of the cultural chronology as it relates to the Central Illinois River valley (Griffin et al, 1970; Cantwell 1980; Munson 1986a).

The Late Marion/Early Morton phase (ca. 400-250 B.C.; Munson 1986a:291), which Griffin (1986:613) excludes from the Havana tradition, includes the use of Marion Thick and "Thin," and later Sister Creeks Punctated and Morton Incised. The Sand Run collection contains little evidence of a well developed sequence of Marion ware (i.e. the early half of this phase), but Sister Creeks and Morton types are present. Significantly, these types from Sand Run evidence little lip flattening and beveling and regular occurrences of cord roughening, even on the lip. These are traits that predate Havana ware and, therefore, should be indicative of a Sand Run occupation that correlates with the Late Marion/Early Morton phase in Illinois. In interior Iowa and the Quad-States region, Morton ware is not prominent, and Sister

Creeks Punctated has a paste like Black Sand Incised. This material probably belongs to the Black Sand tradition.

Munson's next phase, Late Morton/Caldwell (ca. 250-150 B.C.), is not obvious at Sand Run. The diagnostic types of the phase, Morton Incised, Sister Creeks Punctated, Fettle Incised and Neteler Stamped are present, but the latter two do not occur in large numbers. Furthermore, there is not a significant amount of rectilinear trailed designs over plain surfaces, nor are there many vessels without embossing but with flattened, bevelled lips. No collections I have seen from eastern Iowa contain these type and attribute combinations, nor are they present in the Quad-State region. Perhaps my view is a figment of inadequate ceramic samples from large village sites, especially along the Mississippi River. However, the widespread application of trailing in complex nested chevrons and herringbone designs on Black Sand rims from interior Iowa sites suggests that the Black Sand tradition persisted after ca. 150 B.C. and assimilated many Morton/Fettle attributes (see also Prairie Incised var. smoothed in Stoltman 1986:131). Something like the Early Morton phase described in the preceding paragraph may have persisted in the Mississippi trench as well.

The next two phases, Fulton (ca. 150 B.C.-A.D. 1) and Ogden (ca. A.D. 1-200), are inseparable in a mixed collection like Sand Run. Both phases probably are present, as they are at other major Havana sites in the Three Rivers region (e.g. Wolf, Gast Farm, Albany), because large numbers of most Havana pottery types occur. Stamped designs (straight and curved dentate, ovoid and other shapes) and Havana Zoned potteries are prolifically represented, as is "classic" Hopewell ware in the latter phase. The Sand Run collection contains Naples pottery with cord roughened surfaces, an earlier attribute than the largely plain surfaced vessels of the Ogden phase. Compared with the Putney's Landing collection across and slightly downriver, Sand Run has less diversity in bold stamping and zoned motifs. Braun (1977) has observed that the most diverse decorations were made during the middle portion of the Havana tradition. According to this generalization, the Sand Run occupations may represent more of the Fulton phase.

There is no question that some manifestation of the Fulton and/or Ogden phases happened along the major rivers of interior eastern Iowa and along the Mississippi River in the Quad-State region. Actual types and local varieties of Neteler, Hummel and Naples Stamped and Havana Zoned occur in rock shelter sites (Logan 1976) and in open villages (cf. Weichman and Tandarich 1974). Sometimes oddly trailed and punctated decorations reminiscent of Black Sand Incised and Sister Creeks Punctated were added to the Middle Woodland pottery assemblage (e.g. High Bridge Punctated and Trailed; Benn and Rogers 1985). There seems little doubt that populations away from the Three Rivers region shifted rapidly to Havana styles during the late Fulton and Ogden phases (known in Iowa and the Quad-States region as the

Trempealeau and McGregor phases, ca. 100 B.C.-A.D. 300; Logan 1976; Stoltman 1979; Benn 1979).

Munson's succeeding phase is Frazier (ca. A.D. 200-400), also called the Steuben phase by Griffin (1970). Sand Run contains a substantial component like this phase, with Baehr and Weaver wares and the Naples type being present. Also present in small amounts is Levsen Stamped, a post-A.D. 200 pottery of the Allamakee phase in northeastern Iowa (Logan 1976; Benn 1978). The Sand Run assemblage must be compared directly with the Frazier phase, however, because of the dominance of Weaver and Baehr wares. These wares do not appear to penetrate interior eastern Iowa, nor are they evident in the Quad-State region. For example, the assemblage at the Young site on the Cedar River (Benn and Thompson 1977\*) and ceramics from the Quad-State region (Stoltman 1979; Benn 1978) are dominated by the dentate stamped and punctated types in Linn ware.

The Weaver phase (ca. A.D. 400-700) and Allamakee phase (ca. A.D. 300-650) constitute the transitional cultures after the Hopewell horizon in Iowa. Weaver pottery with spartan decoration is the majority series in ceramic assemblages in the Three Rivers region, while Linn ware of the Allamakee phase is distributed in central-eastern and northeastern Iowa. There is enough Levsen Stamped pottery in many site assemblages from the Mississippi River trench to raise the issue of whether Weaver-making people comprised a separate population from those who made Linn ware. Another interpretation also is possible. Levsen Stamped may have only been made early in this phase as a companion type to Baehr in the Three Rivers region, but it was discontinued quickly in favor of Weaver types. Elsewhere in interior eastern Iowa and the Quad-State region, Linn ware continued to be manufactured with the Levsen type being replaced later by Lane Farm Cord Impressed and Stamped (cf. Benn 1979).

What happened immediately after the Hopewell horizon in southeastern and southern Iowa, particularly along the Des Moines River, is open to question. The ceramics from the Lambert site (Fulmer et al. 1977) have the Weaver pattern of upper rim impressions. However, the similarities with Weaver end by noting that the color of the Lambert pottery is brown and that decorations occur on every rim as does cord roughening up to the lip on the exterior surface. The rims of these pots look like

\*The reader is advised to ignore the typing of Cedar ware in the Young site assemblage. Some of the pottery is a Middle Woodland aged ware, but the rims with fine dentate stamps, a row of punctates and rounded lips are Levsen Stamped (e.g. Benn and Thompson 1977: Figure 2c,d). This example of bad typology can be attributed to a deadly combination of youthful exuberance and imprecision on the part of this writer.

material illustrated for the Late Woodland phases in the Salt River valley in northeastern Missouri (Donham and O'Brien 1985). Farther upriver in the central Des Moines valley, Madrid ware has cord roughened and plain surfaces like Weaver but more decorative variation like Linn ware. In general for areas in Iowa away from the Three Rivers region there is a substantial divergence from Weaver which indicates the development of strong local ceramic traditions.

The regionalization of ceramic complexes continued to be manifested after ca. A.D. 650 in Iowa. This is evident in the fact that Munson's Sepo phase of Illinois (ca. A.D. 700-1100) is not relevant to this discussion (see "Cord Decorated" pottery description above). Beginning with Lane Farm Cord Impressed (ca. A.D. 500 or earlier) in the Quad-State region, the notion of decorating pottery rims with cord impressions, fabrics and sometimes rows of small tool marks swept across the prairies. Later, I will relate this decorative horizon to political changes in tribal society. For now, five regional styles (wares?) of corded potteries are recognized in Iowa. 1) The earliest is Lane Farm Cord Impressed, the precursor to any or all of the rest, yet not actually a corded ceramic ware. In the Quad-State region, Madison ware (2) replaced Lane Farm in a continuum of cultural tradition. In the Three Rivers region cord decorated (impressed) potteries with castellations (3) appeared by ca. A.D. 650 and probably were replaced by a more elaborately decorated and plain surfaced series during the later half of the Late Late Woodland period. The cord decorated and plain types with smoothed surfaces, e.g. Minotts ware (4), were manufactured throughout interior eastern Iowa in the latter half of the Late Late Woodland period. In the central and western portions of Iowa Loseke ware (5) was produced after A.D. 700. Where to place the Late Woodland cultures of southern interior Iowa is not yet clear. Roper's (1986:182-194) "undecorated" categories with plain or cord roughened surfaces and the collared rims do not all fit with the Minotts assemblage.

### Conclusion

Discussion about ceramic types and other aspects of the site assemblage will be continued in Chapter VIII. A good way to end this discussion and overview of ceramics is to note problems for future investigation. One difficulty is that some interesting collections housed in public and private institutions have not been studied. This has not prevented writers (like yours truly) from referencing their existence. Additionally, many ceramics are described in published reports without inclusion of metric and tabulated attributes. This perpetuates speculative associations between types and wares. Thirdly, there should be a priority in review and compliance archaeology on studying the Late Woodland ceramic assemblages from Iowa.

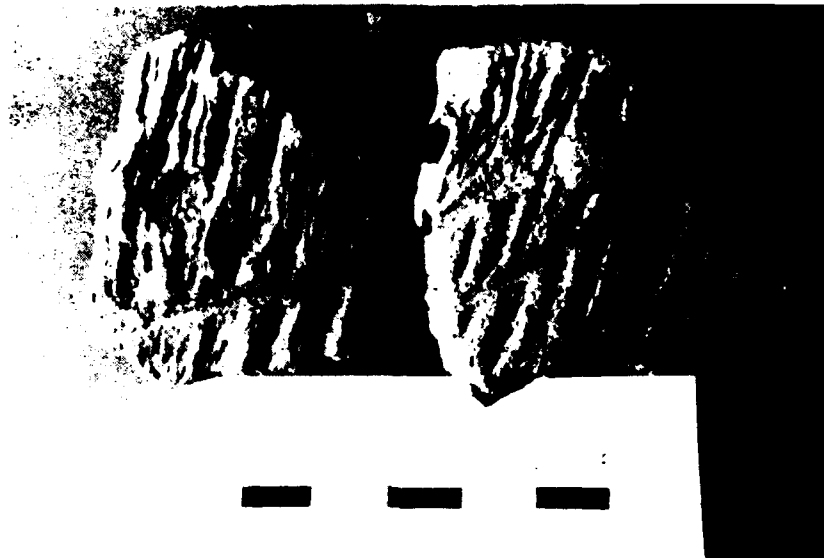

Figure 3.1: Detail of Black Sand Incised sherds showing deeply impressed, coarse cord roughening (13LA38 sherds).

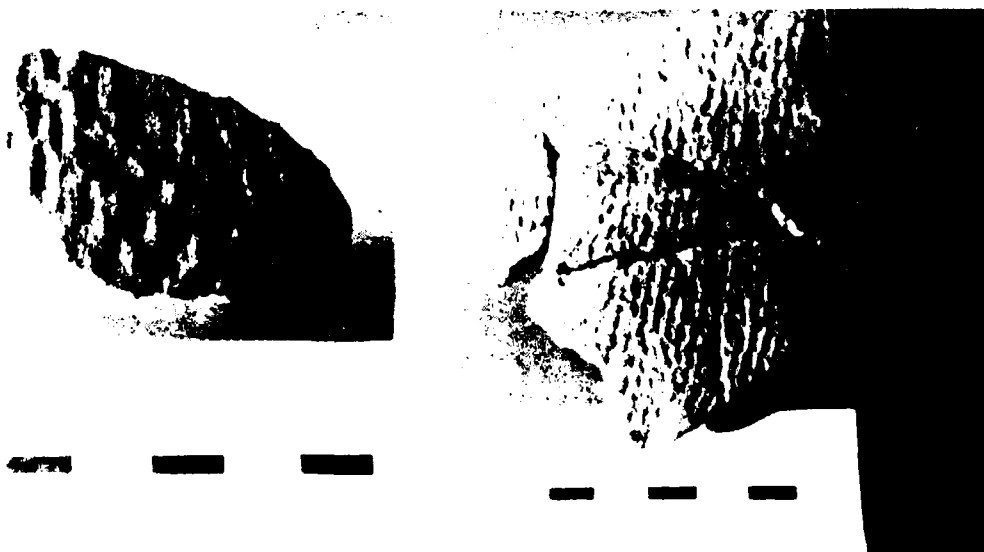

Figure 3.2: Details of late Late J. cord roughened sherds from site 13LA38. Left view, which may result in a "simple cord" roughening; right view, lower left, which may result in a "twisted cord" roughening.

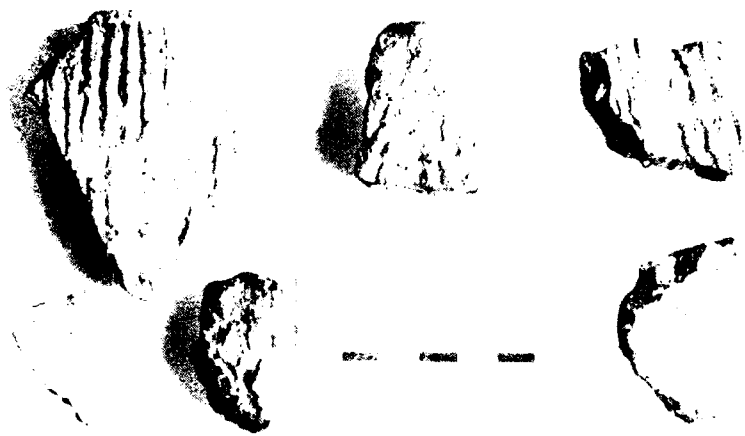





Figure 3.4: Liverpool Cordmarked from 13LA30 and 13LA38; all sherds are rims; lower right specimen is reversed to show the interior lip/rim CWS stamp.



Figure 3.5: Black Sand Incised sherds from 13LA30 and 13LA38; upper two rows are rim sherds (3rd from right, second row is reversed to show interior stamp); lower two rows are lower rim and body sherds.

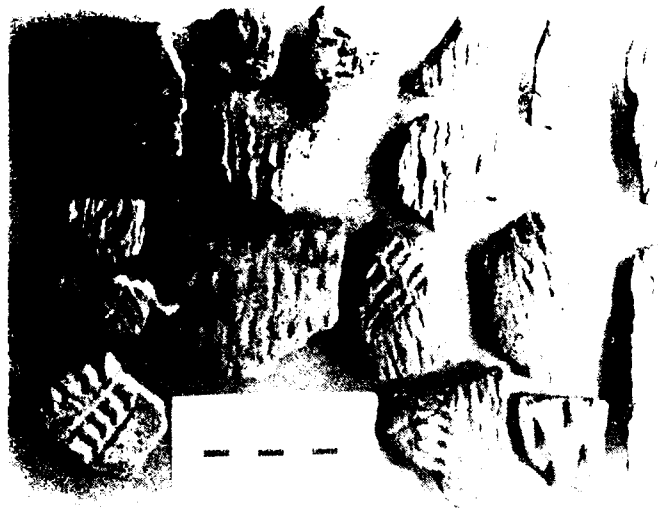
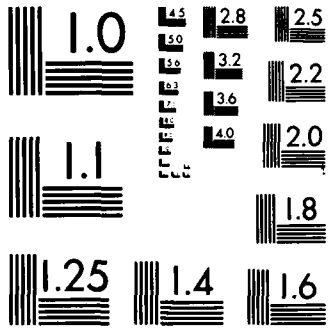

Figure 10: Sister Creeks Punctated from 13LA30 and 13LA55; upper row are rims, lower rows are body sherds; the left specimen in the bottom row is reversed to show a pinched design on the interior.







MICROCOPY RESOLUTION TEST CHART  
NATIONAL BUREAU OF STANDARDS-1963-A



Figure 3.8: Stamped Havana ware from 13LA30 and 13LA38; a) rims (top two rows) and body sherds (bottom two rows) of Naples Stamped; b) Naples Stamped variety diamond; c) Neteler Stamped.

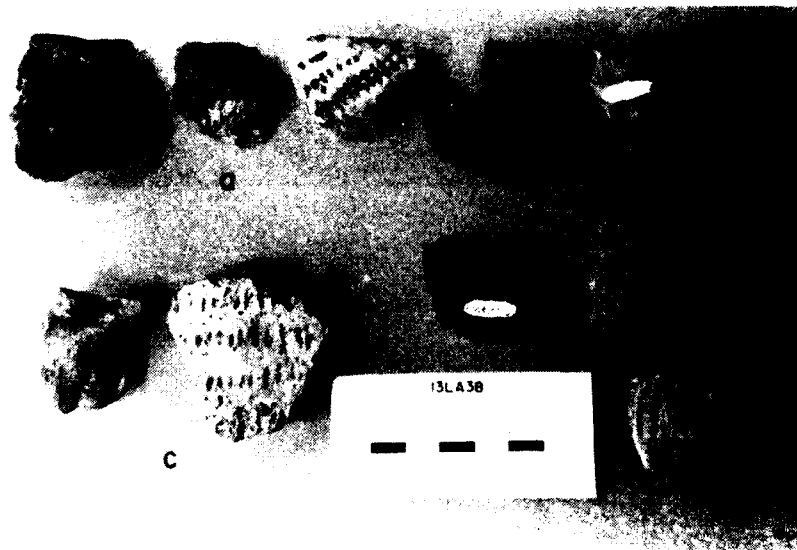

Figure 3.9: Havana ware from 13LA30 and 13LA38; a) Havana Cordwrapped Stick rims; b) Havana Plain rims; c) Havana Cordwrapped Stick body sherds; d) Havana Cordmarked rims (upper left is reversed to show interior lip stamp).

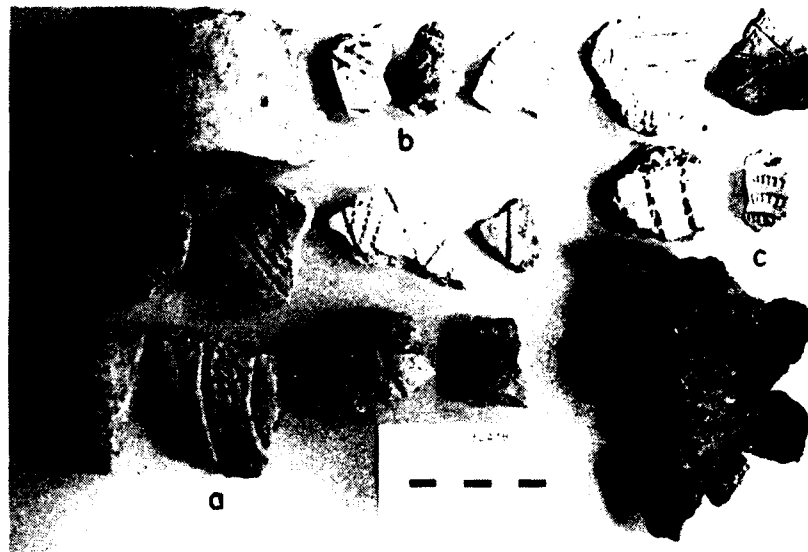

Figure 3.10: Havana ware from 13LA30 and 13LA38; a) Havana Zoned Dentate body sherds; b) Havana Incised body sherds; c) Hummel Stamped (rim at lower right).



Figure 3.11: Sherds from 13LA38; a) (top row) three rims and one zoned rocker body sherd of Hopewell ware; b) (middle row 3 left sherds) limestone tempered Baehr-like with rocker (n=2) and trailed (n=1); (middle row 1 right sherd) grit tempered Pike-like with trailing; c) grit tempered bowl with flanged rim; d) grit tempered Pike-like vessel; e) grit tempered cross-hatched rim and rocker body sherd.

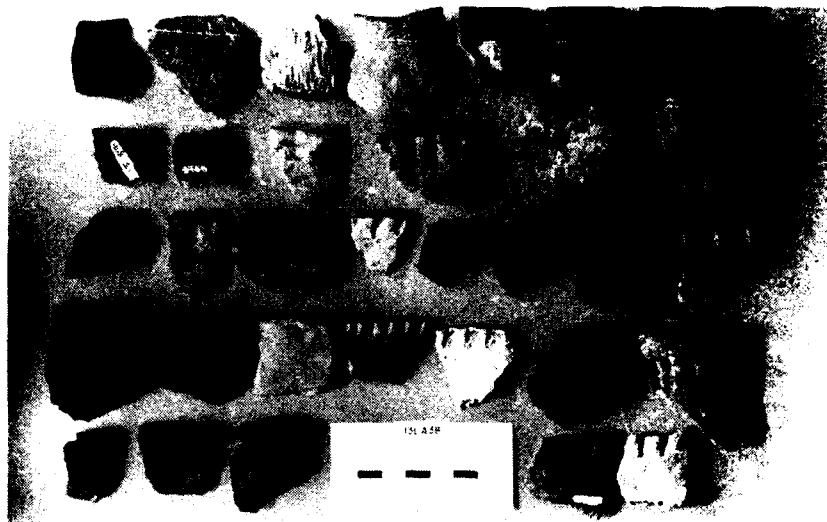

Figure 3.12: Weaver ware from 13LA30 and 13LA38; (upper left) three Weaver Cordmarked rims; (the rest) Weaver Plain rims without decoration (upper row right), with cord-wrapped stick stamps (second row) and with plain tool stamps (bottom three rows).

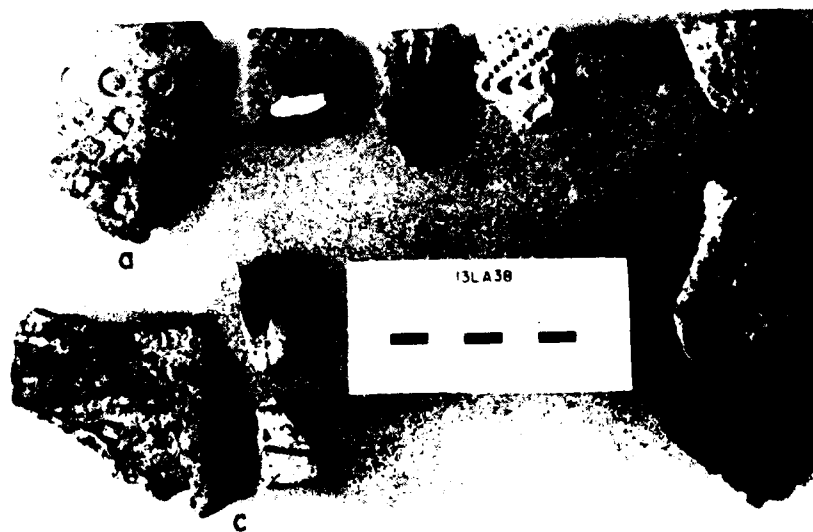

Figure 3.13: Linn ware from 13LA30 and 13LA38; a) Levsen Punctated; b) Levsen Stamped (second from left is CWS, others are Dentate); c) incised body sherds; d) CWS stamped body sherds.

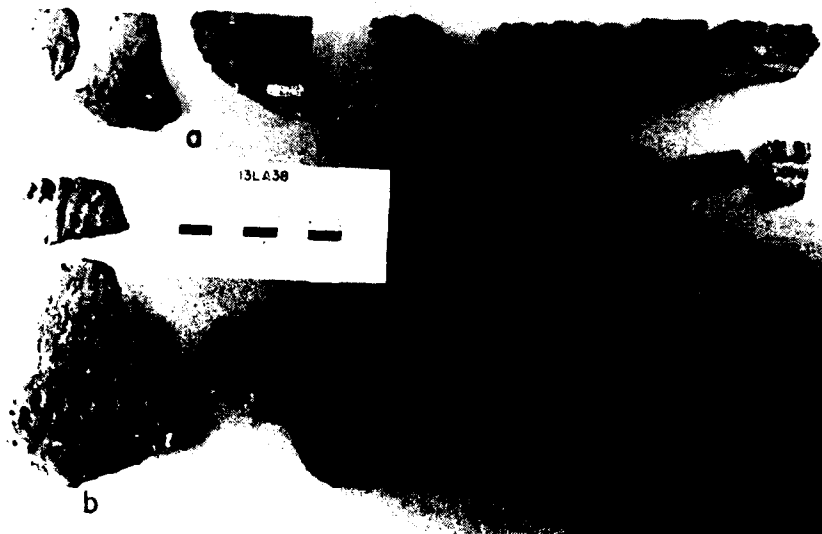

Figure 3.14: Late Late Woodland corded ceramics from 13LA30 and 13LA38; a)(upper left row) three cord roughened rims; b)(lower left) thick cord roughened rim and shoulder sherds with rows of twists; c)(right half all rows) cord decorated rims (top two rows), mid-rims (third row) and rim/shoulders (bottom row).



Figure 3.15: Late Late Woodland plain rims from 13LA30 (Minotts Plain).



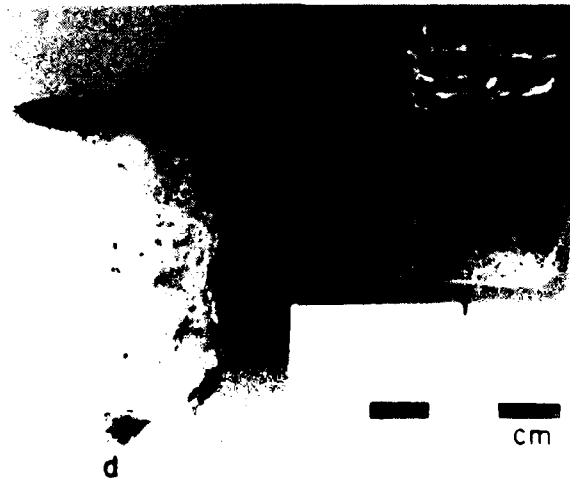
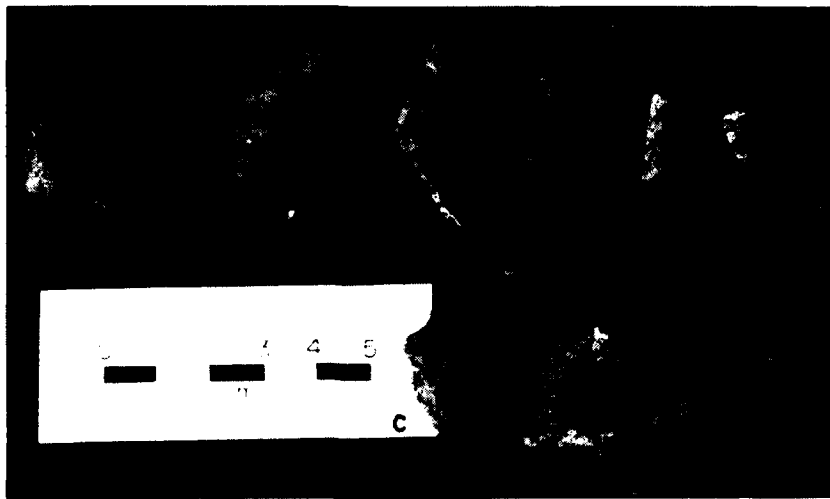

Figure 3.16: Miscellaneous ceramic items from 13LA38; a) two burned clay lumps; b) four shaped fired clay pieces; c) three daub pieces with pole and thatch impressions; d) pipe bowl (stem toward right); e,f) pipe stem fragments; g) "Casper-the-ghost" figure head; h) fragment of disk with punctations (center hole to left).

Table 3.1  
All Excavated and Surface Ceramics  
13LA30/38

Ware Type	rims w/lip	diagnostic w/out lip	% of ware	body sherds	% of assemblage
Oneota	-	-		1	.0
Late Woodland Corded					
Cord Roughened	4	-	6	373	
Cord Impressed	18	37	82.1		
Collared	1	-	1.5		
Late Late Woodland Plain	7	-	10.4		
Sub-total		67		441	16.6
Weaver					
Weaver Plain	78	-	81.3		
Weaver Cordmarked	3	-	3.1		
Linn					
(Levsen) Punctated	1	-	1.0		
(Levsen) Trilled	-	4	4.2		
Levsen CWS	2	3	5.2		
Levsen Dentate	4	1	5.2		
Sub-total		96		96	3.6
Misc Miniature	11	-			
Misc Carinated Shoulder	-	1			
Sub-total				12	.5
Baehr					
Baehr (various)	1	3	50		
Baehr/Pike	2	2	50		
Sub-total		8			.3
Hopewell	4	1	100		
Sub-total		5		5	.2
Havana					
H. Plain	4	1	4.8		
H. Cordmarked	3	-	2.9		
H. Incised	-	5	4.8		
H. Zoned Dentate	-	15	14.3		
H. CWS	3	6	8.6		
Neteler Stamped	1	1	1.9		
Hummel Stamped	1	4	4.8		
Naples Stamped var diamond	-	1	1.0		
Naples Straight Dentate	22	38	57.1		
Sub-total		105		105	4.0
Morton					
Morton/Fettie Incised	2	6	18.6		
Sister Creeks Punctated	10	25	81.4		
Sub-total		43		43	1.6
Liverpool					
L. Cordmarked	17	-	17.2	12	
Black Sand Incised	15	67	82.8		
Sub-total		93		12	4.2
Marion Thick	1	5	100		
Sub-total		6		6	.2
Others					
Thick (> 4mm) Cord Roughened				36	
SOCP				34	1.1
Plain				2	4.1
Thin (< 4mm) Cord Roughened				222	3.8
SOCP				193	3.3
Plain				29	0.5
Damaged body sherds				407	16.1
Damaged rims & decorated				42	1.6
				2657	100

see appendix C for key to ceramic

Table 3.2  
Body Sherds in Excavation Levels  
13LA38

Stratum Lev	A	Damaged	Liverpool Ware	< 7.4mm			> 7.4mm			Late Wood. Corded Ware	Burned Clay	
				Cr	SOCR	P1	CR	SOCR	P1			
I	1	10	-	1*	-	-	-	1	10	21	-	
	2	25	-	-	-	1	4	4	30	65	2	
	3	16	-	1	-	1	2	2	44	35	1	
	4	9	-	2	-	6	2	3	52	12	14	
	fea's									ves.		
II	5	2	-	-	2	-	2	11	19	-	4	
	6	1	-	-	-	1	-	4	30	1	-	
	7	-	-	-	-	-	-	-	-	-	-	
	7	10	-	1*	1	1	4	7	38	-	27	
							(6 bur)	(33 bur)				
B, TU 647												
I	3-4	-	-	-	-	-	-	-	1	-	1	
	5	26	-	-	-	-	-	-	14	-	10	
	6	22	-	-	-	-	1	2	18	11	21	
	6	fea's	-	-	-	-	-	-	-	1	-	
	7	11	-	-	1	2	2	6	27	4	41	
	8	7	-	1	-	2	3	7	26	1	63	
	9	4	-	-	7	-	-	-	2	-	15	
	10	2	-	-	3	-	-	-	2	-	7	
	11	-	-	-	-	-	-	-	1	-	-	
	11	fea's	27	-	25ves	49 2ves	39ves	19	16	100	-	126
	12	12	-	-	-	-	-	-	-	-	-	4
	13	-	-	-	-	-	-	-	-	-	-	3
	14	-	-	-	-	-	-	-	-	-	-	7
	14	fea's	-	-	-	-	-	-	-	-	-	13
15	15	-	-	-	-	-	-	-	-	-	8	
16	-	-	-	-	-	-	-	-	-	-	2	
17	-	-	-	-	-	-	-	-	Burrow 3	-	-	
17	17	-	-	-	-	-	-	-	-	-	1	
17	17	-	-	-	-	-	-	-	-	-	-	
18	-	-	-	-	-	-	-	-	-	-	-	
19	-	-	-	-	-	-	-	-	-	-	-	
19	19	-	-	-	-	-	-	-	-	-	1	
	fea's											
									(41 bur)			
C & TUS												
I	1	8	-	-	-	-	-	-	5	3	2	
	2	7	-	32*	-	-	-	1	6	13	2	
	3	28	-	2*	1	3	4	51 <sup>a</sup>	29	60	5	
	4	39	-	1	-	1	10	2	47	80	25	
	5	66	-	5	1	3	9	8	63	41	24	
	fea's											
II	6	34	3	5	1	3	15	16	33	16	25	
	7	22	3	17	12	11	11	8	55	1	68	
	8	10	2	12	2	14	12	13	37	-	25	
	9	24	3	15	5	13	13	11	21	1	47	
	9	fea's	2	-	1	-	-	-	3	-	2	
III	10	14	-	3	3	6	8	2	25	-	21	
	11	1	1	-	-	1	-	-	7	-	18	
	12	-	-	1	-	-	1	-	-	-	42	
	13	-	-	-	-	-	-	-	-	-	23	
	14	-	-	-	-	-	-	-	-	-	56	
	15	-	-	-	-	-	-	-	-	-	6	
	16	-	-	-	-	-	-	-	-	-	-	
16	16	-	-	-	-	-	-	-	-	-	13	
	fea's											
						(1bur)		(2 bur)	(34bur)			
				338	308	378	118	128	768			

\*Thick Late Woodland Corded Ware  
bur - burnished  
# limestone temper

Table 3.3  
Liverpool Cordmarked Attributes

13LA30/38  
n = 17 rims

Central IL R. Valley  
(Munson 1986 :284)  
3 rims, 107 sherds

Form	n	% or metrics	n	%/metrics	
lip: round	10	59%	2	67%	
round-flat	5	29%	-	-	
flat	2	12%	1	33%	
extruded	9/17	53%	1/3	33%	
rim: straight	12	71%	NA	-	
slightly curved	5	29%	NA	-	
orientation: in	8	67%	-	-	
vertical	3	25%	2	67%	
flare	1	8%	1	33%	
<b>Surfaces</b>					
lip: plain	9	56%	3	100%	
SOCR	3	19%	-	-	
CR	4	25%	-	-	
rim: CR	17	100%	110	100%	
<b>Size(mm)</b>					
		$\bar{x}$	s	$\bar{x}$	s
lip thickness	17	7.4	1.9	NA	-
rim wall thickness	17	8.8	1.3	3	7.1
body wall thickness	--			107	7.8
orifice dia	10	171	40.4	3	153
<b>Inter. Upper Rim Decor</b>					
none	15		88%	3	100%
CSW	2	lg wd 18.5x6.8	12%	-	-
<b>Lip Decor</b>					
none	16		94%	3	100%
tool	1		6%	-	-
<b>Exter. Decor</b>					
none	17		100%	110	100%
<b>Embossing</b>					
		$\bar{x}$	s	$\bar{x}$	s
none	1/13		8%	NA	-
Node dia.	9	10.4	1.68	NA	-
Node to lip dist.	12	19.	-	2	22
Node to node dist.	9	19.9	-	1	15
<b>Cord type - S</b>					
	11/11		100%	60	100%
<b>Cord direction lower</b>					
lt to upper rt	5/17		29%	1/3	33%

Table 3.4  
Black Sand Incised Attributes

Form	13LA30/38 15 rims, 67 other sherds		Central Illinois River Valley (Munson 1986a:281)		Central Des Moines River Valley (Benn & Rogers 1985)			
	n	metrics or %	n	metrics or %	n	metrics or %		
lip: round	8	53%	12	70%	7	64%		
round-flat	6	40%	4	24%	2	18%		
flat	1	7%	1 (bev)	6%	1 groove & 1 pt	18%		
everted/extruded	8/15	53%	3/17	-	-	-		
rim: straight	9	56%	na	-	10	91%		
slightly curved	7	44%	na	-	1	9%		
rim orientation: in	5	38%	1	8%	5	45%		
vert.	6	46%	9	75%	5	45%		
flare	2	15%	2	17%	1	10%		
shoulder: none	5	62%	-	-	-	-		
steep	3	38%	-	-	8	100%		
<b>Surface (interior plain)</b>								
lip: plain	11	73%	17	100%	9	82%		
SOCR	1	7%	-	-	-	-		
CR	3	20%	-	-	2	18%		
rim: SOCR	1	6%	-	-	-	-		
CR & decor.	17	94%	17	100%	11	100%		
body: SOCR	2	3%	-	-	-	-		
CR & decor.	68	97%	152	100%	9	100%		
<b>Size (mm)</b>								
		$\bar{x}$	s	$\bar{x}$	s	$\bar{x}$	s	
lip thickness	14	6.1	1.06	na	-	11	5.9	1.9
rim wall thick.	19	9.	1.74	17	7.8	11	7.1	1.3
body wall thick.	61	8.3	1.56	na	-	8	8.6	1.6
orifice dia	12	176.7	47.93	6	167	10	181	39.3
body dia.	27	207.4	49.43	na	-	7	215.7	48.6
<b>Interior upper rim decor.</b> ("int. lip")								
none	9	60%	12	71%	10	91%		
fingernail	4.4mm	2	13%	(tool) 1	6%	(tool) 1	9%	
CWS	apart	4	27%	4	24%	-	-	
<b>Lip Decoration</b> ("ext. lip")								
none	14	93%	15	88%	5	71%		
tool	1	7%	2	12%	2 (1 groove)	29%		
<b>Ext. Upper Rim Decor.</b> ("vert. lip")								
none	7	37%	15	88%	1	10%		
horz. lines	2	11%	-	-	7	70%		
oblique lines	4	21%	-	-	1 (zone)	10%		
stabs	3	16%	2	12%	1	10%		
fingernail	3	16%	-	-	-	-		
<b>Lower Rim Body Decor</b>								
horiz. paral. lines	52	56%	9	56%	4	50%		
oblique lines & zones	27	29%	4	25%	1 (vert)	12%		
stabs/slashes	7	8%	1	6%	-	-		
herringbone	4	4%	-	-	-	-		
x-hatch	1	1%	1	6%	1	12%		
nested lines	2	2%	1 (chevron)	6%	2 (1 chevron)	25%		
line width	82	2.8	.87	-	-	-		
line dist. apart	77	4.1	2.24	-	-	-		
<b>Embossing - none</b> 2/18 11%								
node diameter (mm)	14	10.3	1.37	na	-	9	7.4	1.5
node to lip dist.	12	18.4	-	15	23.0	9	12.2	-
node to node dist.	9	19.5	-	7	17.4	9	14.8	-
Cord type - S	52	100%	45	100%	9	100%		
					1 punctated			
Cord Direction (body)	14/68	lower lt- 20%	9/13	69%	1/10	10%		
		upper rt						

Table 3.5  
Sister Creeks and Morton Incised Attributes  
13LA30/38

Form:	Sister Creeks Punctate 9 rims, 26 sherds		Morton/Fettie Incised 2 rims, 6 sherds			
	n	%	n	%		
lip: round	4	44%	1	50%		
round-flat	3	33%	1	50%		
flat	2	22%	-	-		
extruded	3	33%	2	100%		
beveled	1	11%	-	-		
rim: straight	6	54%	2	100%		
slightly curved	5	46%	-	-		
orientation: in	4	44%	-	-		
vertical	5	56%	2	100%		
flare	-	-	-	-		
<b>Surfaces</b>						
lip: plain	6	67%	1	50%		
SOCR	1	11%	-	-		
CR	2	22%	1	50%		
rim: plain	3	21%	1	25%		
SOCR	1	7%	-	-		
CR/decor	10	71%	3	75%		
body: SOCR	2	8%	2	40%		
CR	23	92%	-	-		
decor	-	-	3	60%		
<b>Size:</b>						
lip thickness	9	$\bar{x}$ 7.6	$s$ 1.75	2	$\bar{x}$ 9.65	$s$ -
rim wall thickness	14	8.3	1.44	3	8.8	-
body wall thickness	21	8.5	1.30	5	8.9	-
oriface dia.	8	195	41.75	2	190	-
body dia.	7	234.3	68.03	3	212	-
<b>Interior Upper Rim Decoration</b>						
none	9	100%	-	-	-	
CWS	-	-	2	100%	-	
<b>Lip Decoration</b>						
none	7	78%	2	100%	-	
CWS	1	11%	-	-	-	
punctate	1	11%	-	-	-	
<b>Exterior Upper Rim Decor</b>						
none	3	33%	-	-	-	
fingernail row	1	11%	-	-	-	
stab columns	stabs	-	-	-	-	
oblique lines w/stabs	2.5x6.8	56%	(stab) 2	6.6x2m	100%	
<b>Lower Rim/Body Decor.</b>						
interior pinches	1	3%	-	-	-	
rows(horiz) of designs	6	18%	2	29%	-	
columns of designs	24	71%	-	-	-	
design zones (nested w/ line)	3	9%	3	43%	-	
oblique designs	-	-	1	14%	-	
herringbone	-	-	1	14%	-	
design size	30	$\bar{x}$ 3.3x8.6	$s$ -	-	-	
dist. apart	27	2.39	-	-	-	
Incised line width	3	3.0	-	8	2.2	.59
Distance between lines	-	-	-	9	2.9	1.58
<b>Embossing</b>						
none	1	10%	-	-	-	
node diameter (mm)	8	9.5	.86	3	10.5	-
node to lip dist.	7	19.8	-	3	23.4	-
node to node dist.	5	17.9	-	3	27.1	-
Cord type - S	20/20	100%	-	2/2	100%	-
Body Cord Direction(lower lt. to upper rt.)	4/27	15%	-	1/8	12%	-

Table 3.6  
Attributes of Havana Ware  
13LA30/38

Form	Naples Dentate Stamped 22 rims 38 sherds		Havana CWS 3 rims 6 sherds		Havana Cordmarked 3 rims		Havana Plain 4 rims 1 sherd		Havana Incised 5 sherds		Havana Zoned Dentate 15 sherds		Hummel Stamped 1 rim 3 sherds	
	n	% metrics	n	% metrics	n	% metrics	n	% metrics	n	% metrics	n	% metrics	n	% metrics
lip: round	1	4%	-	-	1	-	1	25%	-	-	na	-	-	-
lip: round-flat	4	18%	1	33%	2	-	1	25%	-	-	-	-	-	
lip: flat	17	77%	2	67%	-	-	2	50%	-	-	-	-	-	
lip: bevelled	19/22	86%	2/3	1/3	-	-	2/4	50%	-	-	-	-	-	
rim: straight	14	42%	1	17%	1	-	3	60%	-	-	1	-	1/1	
rim: slightly curved	17	52%	4	67%	2	-	2	40%	-	-	2	-	3	
rim: curved	2	6%	1	17%	-	-	-	-	-	-	-	-	-	
rim: channelled	5/22	23%	2/6	33%	-	-	-	-	-	-	-	-	-	
orientation:	-	-	-	-	-	-	-	-	-	-	-	-	-	
in	-	-	-	-	-	-	-	-	-	-	-	-	-	
vertical	9	50%	3	100%	3	-	1	-	-	-	na	-	-	
flare	9	50%	-	-	-	-	-	-	-	-	-	-	-	
Surfaces	-	-	-	-	-	-	-	-	-	-	-	-	-	
lip: SOCR	1	5%	-	-	1	-	4	100%	-	-	na	-	-	
lip: pl	20	95%	3	100%	3	-	-	-	-	-	-	-	1	
rim: CR	5	9%	1	11%	3	-	-	-	-	-	-	-	-	
rim: SOCR	8	14%	2	22%	-	-	-	-	1	-	-	-	-	
lip: pl	45	78%	6	67%	-	-	5	100%	2	-	6	100%	4	
body: CR	1	9%	-	-	-	-	-	-	1	-	-	-	-	
body: SOCR	2	18%	-	-	-	-	-	-	-	-	-	-	-	
lip: pl	8	73%	-	-	-	-	1	100%	3	-	10	100%	1	
Size	-	-	-	-	-	-	-	-	-	-	-	-	-	
lip thickness	21	9.5	3	6.7	3	8.5	4	7.8	na	-	na	-	1	6.1
rim thickness	53	8.9	9	9.0	3	9.6	5	8.6	3	7.5	5	7.0	4	8.9
body wall thickness	5	8.5	-	-	-	-	-	-	3	9.0	10	7.9	1	7.3
orifice dia.	15	210.3	2	197.5	3	196.7	1	210	2	195	-	-	1	230
body dia.	8	236.2	45.05	-	-	-	-	-	-	-	6	193.3	-	-





Table 3.7  
Composition of Middle Woodland Ceramic Assemblages

Ware Type	Clear Lake (Flowler 1952)		Steuben (Morse 1970)		Kuhne (Loy 1968)		Apple Creek (Loy 1968)		Sand Run 13LA38		FTD Site (Benn 1978)		Central Des Moines River Valley (Benn & Rogers 1985)	
	n	%	n	%	n	*	n	*	n	%	n	%	n	%
Havana	1316	12.4	37	2.2	297		221		60	50.8	139	65.	16	19.5
Naples Stamped	17	0.2	-	-	32		46		9	7.6	28	13.1	-	-
Havana CMS	459	4.3	33	1.9	44		188		15	12.7	11	5.1	-	-
Havana Zoned (all)	102	1.0	-	-	5		119		1	0.8	6	2.8	-	-
Naples Ovoid	220	2.1	104	6.1	139		30		5	4.2	-	-	-	-
Hummel Stamped	66	0.6	1	0.1	22		82		2	1.7	-	-	-	-
Neteler Stamped	18	0.2	9	0.5	-		-		-	-	-	-	3	3.7
Victory Brushed	48	0.5	-	-	-		-		-	-	-	-	-	-
Fettie Incised	1960	18.4	540	31.9	present		present		3	2.5	9	4.2	36	43.9
Havana Plain	6157	57.9	197	11.6	present		present		5	4.2	8	3.7	16	19.5
Havana Incised (Trailed)	-	-	73	4.3	43		present		5	4.2	13	6.1	10	12.2
Havana Bossed	-	-	-	-	9		-		-	-	-	-	-	-
Steuben Punctated	-	-	620	36.6	281		5		-	-	-	-	-	-
Hopewell	258	2.4	55	3.2	present		present		5	4.2	-	-	1	1.2
Baehr	14	0.1	24	1.4	present		present		8	6.8	-	-	-	-
Totals	10635		1693		872		691		118		214		82	

\* Plain & Cordmarked types  
not available to  
calculate %

Table 3.8  
 Attributes of Hopewell, Baehr & Beahr/Pike Ceramics  
 13LA30/38

Form	Hopewell Incised 3 rims, 1 sherd		Baehr 1 rim, 3 sherds		Baehr/Pike 2 rims, 2 sherds	
	n	% metrics	n	% metrics	n	% metrics
lip: round	1	-	-	-	-	-
round-flat	2	-	-	-	1	-
flat	-	-	1	-	1	-
bevelled	-	-	1/1	100%	1/2	50%
rim: straight	-	-	-	-	1	-
slightly curved	4	100%	2	-	1	-
curved	-	-	-	-	-	-
channelled	3/3	100%	1/1	100%	2/2	100%
orientation: in	1	-	-	-	-	-
vertical	2	-	1	-	-	-
flare	-	-	-	-	1	-
<b>Surfaces</b>						
lip: pl	3	100%	1	-	2	100%
rim: pl	4	100%	2	100%	3	100%
body: pl	1	100%	2	67%	2	100%
brushed	-	-	1	33%	-	-
<b>Size</b>						
lip thickness	3	$\bar{x}$ 4.4	1	$\bar{x}$ 4.5	2	$\bar{x}$ 7.3
rim thickness	4	4.4	2	5.8	3	7.7
body wall thickness	-	-	2	6.0	2	7.7
orifice dia.	3	156.7	1	120	2	190
body dia.	1	200	-	-	2	255
channel wd/dp.	3	11 x 1.4mm	1	9 x 1mm	2	24.6x1.9
Interior Rim Decor. - None	3	100%	1	100%	2	100%
Lip Decoration - None	3	100%	1	-	2	100%
<b>Exterior Upper Rim decor</b>			<b>Present</b>			
x-hatch	1	-	-	-	2	100%
brushing	1	-	-	-	-	-
pl rocker	1 w/cws	-	-	-	-	-
zone wd.		14.9mm		15mm		20.4mm
<b>Ext. Lower Rim/Body Decor.</b>						
horiz. line	1	-	1 x-hatch lines w/den.	-	1 pl. rocker	-
column of rocker den	1	-	1 none	-	1 line	-
curved band pl. rocker	1	-	1 pl. rocker	-	1 line w/ brush & den	-
Incised Line Width	2	2.4mm	1	2.9mm	4	1.9mm
<b>Punctuation</b>						
none	1	-	-	-	-	-
size	2	3.6 x 2.2	1	3.2 x 3.8	1	4.5 x 4.3
from left	-	-	1	-	1	-
from right	2/2	-	-	-	-	-
Dentate tooth (lg, wd)		1.5 x 1		3.2 x 1.0		
Temper Types	4 limestone		3 grit, 1 limestone		3 grit, 1 grit/limestone	

Table 3.9  
Attributes of Weaver Ware  
13LA30/38

Form	Weaver Cordmarked 3 rims		Weaver Plain 78 rims		
	n	% metrics	n	% metrics	
lip: round	2	-	50	65%	
round-flat	1	-	25	32%	
flat	-	-	1	1%	
point	-	-	1	1%	
extruded	-	-	6/50	12%	
rim: straight	3	-	13	17%	
slightly curved	-	-	33	44%	
curved	-	-	29	39%	
channelled	-	-	4/77	5%	
orientation: in	1	-	4	7%	
vertical	2	-	17	31%	
flare	-	-	34	62%	
<b>Surfaces</b>					
lip: plain	3	100%	78	100%	
rim: CR	3	100%	-	-	
plain	-	-	78	100% 9 bur	
body: CR	-	-	1	1%	
SOCR	-	-	1	1%	
plain	-	-	8	80%	
<b>Site</b>					
		$\bar{x}$		$\bar{x}$	s
lip thickness:	3	5.2	77	4.6	1.06
rim thickness:	3	6.8	78	5.5	1.16
orifice dia.	2	190	44	199.3	45.97
<b>Inter. Upper Rim Decor</b>					
none	2	-	77	99%	
tool	1	-	1	1%	
<b>Lip Decoration</b>					
none	3	100%	73	95%	
tool	-	-	3	4%	
punctate	-	-	1	1%	
<b>Exter. Upper Rim Decor</b>					
		$\bar{x}$		$\bar{x}$	s
none	2	67%	21	28%	
tool	-	-	43	8 obl lt 1 obl rt	57%
CWS	1 obl	-	11	3 obl lt	14%
reed punctate	-	-	1		1%
impression lg x wd	1	18.9 x 4.9	53	9.9 x 5.0	
distance apart	1	7.1	49	5.2	2.18
<b>Embossing</b>					
		$\bar{x}$		$\bar{x}$	
none	-	-	55	98%	
dia.	3	8.1			
node to lip	3	16.8	1	18.3	
node to node	2	15.3			
Body Cord Type	3/3 S		5 S		
CWS Cord Type	1 S		7 S		

Table 3.10  
Attributes of Linn Ware  
13LA30/38

Form	Levsen Dentate 3 rims, 2 sherds		Levsen CWS 2 rims, 3 sherds		Misc Trailed 4 sherds	
	n	% metrics	n	% metrics	n	% metrics
lip: round	1	-	-	-	-	-
round-flat	1	-	1	-	-	-
flat	1	-	1	-	-	-
bevelled	1/3	33%	2/2	100%	-	-
rim: straight	2	-	-	-	-	-
slightly curved	1	-	2	40%	-	-
curved	-	-	3	60%	1	-
channelled	1/3	33%	2/2	100%	-	-
orientation: vertical	1	-	-	-	-	-
flare	2	-	2	-	-	-
<b>Surfaces</b>						
lip: plain	3	100%	2	100%	-	-
rim: plain	5	100%	5	100%	1	-
body: CR	-	-	1	-	-	-
plain	1	-	2	-	3	100%
<b>Site</b>						
lip thickness	3	$\bar{x}$ 5.3	2	$\bar{x}$ 5.8	-	-
rim thickness	5	6.1	5	6.1	1	5.1
bodywall thickness	1	6.5	1	5.6	3	5.1
orifice dia	3	150	2	130	1	150
channel wd/dp		irregular	2	16.3x1	-	-
Interior Rim Decor - none	3	100%	2	100%	NA	-
Lip Decoration - none	3	100%	2	100%	NA	-
<b>Exterior Upper Rim Decor</b>						
dentate	3(2obl)	-	-	-	-	-
CWS	-	-	2obl	-	-	-
stamp lg x wd	3	12.1 x 2.7	2	16.2 x 1.8	-	-
<b>Ext. Lower Rim/Body Decor</b>						
horiz. den	1	-	1cws	-	1 line	-
vert. den	1	-	2cws	-	2 obl lines	-
vert den. w/line	1	-	-	-	1 paral. lines	-
rocker den.?	1	-	-	-	-	-
<b>Punctates/Embossing</b>						
none		$\bar{x}$		$\bar{x}$		
dia.	1B	7.3	1P	rt 3.7 x 4.4	-	-
node to lip	1	15.8	1	13.5	-	-
node to node	-	-	1	2.4	-	-
Cord Type	-	-	2S	-	NA	-
Dentate tooth lg x wd	6	2.0 x 2.0	1	replied S stamp	1 line wd. $\bar{x}$ = 2	-

Table 3.11  
 Attributes of Miniature Vessels  
 13LA38

Form	n	ll rims	% metrics
lip: round	7		64%
point	4		36%
rim: straight	2		18%
slightly curved	5		45%
curved	3		27%
bowl	1		9%
orientation: in	1		20%
vertical	3		60%
flare	1		20%
shoulder: none	4		67%
expanding	2		33%
<b>Surfaces</b>			
lip: plain	11		100%
rim: brushed	1		9%
SOCR	1		9%
pl	9		82%
<b>Size</b>			
rim thickness	11	$\bar{x}$ 5.9	s 1.90
orifice dia.	3		50, 60, 100 mm
body dia.	2		50mm
<b>Inter. Rim Decor - None</b>			
	9		100%
<b>Lip Decoration - None</b>			
	11		100%
<b>Exter. Upper Rim Decor</b>			
None	9		82%
Oblique Lines	1		9%
Oblique dentate	1		9%
<b>Lower Rim/Body Decor</b>			
none	9		90%
punctate row	1	dia. 2.2	10%
<b>Embossing</b>			
dia.	2	$\bar{x}$ 6.0	
node to lip	1	20.5	
node to node	1	14.5	
<b>Temper</b>			
none	5		45%
sand	4		36%
grit	2		18%

Table 3.12  
Composition of Early Late Woodland Ceramic Assemblages

	Albany Village (Benchley et al. 1977)	Weaver Village (Wray & McNeish 1961)	Clear Lake (Fowler 1952)	Sand Run	FTD Site (Benn 1978)	SW Wisconsin (Stoltzman 1979)	Central Des Moines River Valley (Benn & Rogers 1985)
Weaver Plain	n=72	1586	8202**	78	9.3%	35	Madrid 19
Rocker	5	-	-	-	-	-	-
Brushed	2	-	-	-	-	-	-
CWS	12	na	668	11	-	2	-
Plain stamp	42	-	71	43	-	25	-
Undecorated rim	10	-	248	21	14	18	15
Punctated	1	-	45	1	-	-	-
Decorated lip	-	-	246	4	-	-	4
Weaver CM	7	257	5581**	3	0.7%	23*	Madrid 43
Undecorated rim	5	-	-	2	1	11	37
Plain stamp	2	na	-	-	-	-	-
CWS	-	-	-	1	-	8	6 on lip
Linn Ware							
Levsen Dentate (linear) Stamped	-	-	-	5	47	43	24
Levsen CWS	-	-	-	5	2	16	-
Levsen Punctated	-	-	-	1	1.3%	10.9%	-
(Levsen) Trilled	-	-	-	1	-	12	10
Lane Farm Cord	-	-	-	1	-	-	-
Impressed	-	-	-	-	86	15	-
Plain Bossed	-	-	-	-	57.3%	10.2%	-
						2.0%	-

\*included 4 "smooth band" variety

\*\* includes body sherds

Table 3.13  
Attributes of Late Late Woodland Wares  
13LA30/38

Form	n	Plain 7 rims		Cord Roughened 4 rims		Cord Decorated 18 rims, 16 mid rim, 16 shoulder		
		%	metrics	%	metrics	%	metrics	
lip: round	3	43%		3	75%	13	72%	
round-flat	4	57%		-	-	3	17%	
flat	-	-		-	-	1	6%	
pointed	-	-		1	25%	1	6%	
bevelled out	2/7	29%		1/4 thickened	25%	2/18 thickened	11%	
extruded	4/7	57%		-	-	1/18	6%	
rim: straight	1	14%		-	-	7	18%	
slightly curved	2	29%		1	25%	16	41%	
curved	4	57%		3	75%	16	41%	
orientation: in	-	-		-	-	1	12%	
vertical	2	33%		2	67%	5	62%	
flare	4	67%		1	33%	2	25%	
<b>Surfaces</b>								
lip: CR	-	-		1	25%	1	6%	
plain	7	100%		3	75%	15	94%	
rim: CR/decor	-	-		3	75%	29	80%	
brushed	-	-		-	-	1	3%	
pl	7 6bur	100%		1 SOCR	25%	6	17%	
<b>Site</b>								
lip thickness	7	6.8	.80	4	4.4	18	4.7	1.08
rim thickness	7	6.6	.89	4	5.2	47	5.6	1.17
orifice dia.	5	214	-	2	160	17	204.1	48.48
<b>Inter. Upper Rim Decor</b>								
none	7	100%		2	50%	13	72%	
horiz. cords	-	-		-	-	4	22%	
vert. cords	-	-		2 tool	50%	1	6%	
<b>Lip Decoration</b>								
none	5	71%		3	75%	5	28%	
tool	2	29%		-	-	-	-	
cord imp.	-	-		-	-	6	33%	
cord scalloped	-	-		1	25%	7	39%	
<b>Exter. Upper Rim Decor.*</b>								
none	7	100%		4	100%	1	17%	
horiz. cord. imp.	-	-		-	-	1	17%	
vert. cord. imp.	-	-		-	-	4	67%	
<b>Exter. Middle Rim Decor</b>								
none	6	86%		4	100%	1	2%	
horiz. cord. imp.	-	-		-	-	40	87%	
horiz. & vert. cord imp.	1 (tool)	14%		-	-	1	2%	
cord chevron	-	-		-	-	3	6%	
oblique cord imp.	-	-		-	-	1	2%	
<b>Exter Lower Rim Decor</b>								
none	-	-		2	100%	2	10%	
cord knots	-	-		-	-	1	10%	
cord twists	-	-		-	-	5	31%	
cord loops	-	-		-	-	1	10%	
punctate row	-	-		-	-	2	10%	
CWS stamp	-	-		-	-	1	5%	
<b>Cord Decoration Type</b>								
cord diameter	na	-		1	3.8	41	2.3	56
cord beads per CM	-	-		1	3	42	2.7	.81
cord spacing	-	-		1	3.2	18	2.6	68
cord type	-	-		1 Z	-	18Z 25	23 replied Z, 3 replied S	
<b>Body Cord Type</b>								
Lower Rim Decoration Size	na	-		1 Z	-	1S 7Z (3"simple stamped")		
	-	-		-	-	lg 6.9 x wd 1.7mm		

\* differs from Middle Rim Decoration

Table 3.14: Trans-Iowa Comparison of Cord Decorated Types

Form	13LA38/30 n=50		Madison Fabric Impressed n=135 (Benn 1978:275)			
	n	% - metrics	n	% - metrics		
lip: round	16	89%	63	57%		
flat	1	6%	45	41%		
point	1	6%	2	2%		
rim: straight	7	18%	18	13%		
curved	32	82%	117	87%		
channelled	-	-	-	-		
orientation: in	1	12%	29	29%		
vertical	5	62%	40	40%		
flare	2	25%	32	32%		
<b>Surfaces</b>						
rim: pl & socr	6	17%	5	4%		
br/cr/decor	29	83%	125	96%		
<b>Size</b>						
lip thickness	18	4.7	1.08	109	3.37-3.90	.71-1.46
rim thickness	47	5.6	1.17	118	4.14-4.86	.64-1.10
lip-rim difference	-	.9	-	109	.62-1.5	-
<b>Inter Upper Rim Decor</b>						
none	13	72%	57	52%		
horiz. cords	4	22%	19	17%		
vert. cords	1	6%	33	30%		
<b>Lip Decoration</b>						
none	5	28%	69	63%		
cord imp.	13	72%	41	37%		
<b>Exter. Upper Rim Decor.*</b>						
present	6	13%	46	42%		
absent	40	87%	63	58%		
<b>Exter Middle Rim Decor</b>						
Plain or SOCR	-	-	-	-		
rocker stamp	-	-	-	-		
horiz cords	40	87%	117	88%		
vert cords	-	-	-	-		
oblique cords	1	2%	7	5%		
horiz & vert cords	1	2%	1	1%		
horiz. & oblique cords (Chevron)	3	6%	8	6%		
cords & knots	-	-	1	1%		
cord twist rows	-	-	-	-		
none	1	2%	-	-		
<b>Exter Lower Rim Decor.</b>						
rocker stamping	14/16	88%	41/49	84%		
horiz & vert twists	5	31%	16	39%		
knots	3	19%	9	22%		
loops	3	19%	9	22%		
paired twists	-	-	1	2%		
punctate row	2	12%	4	10%		
zigzag or pendent	-	-	2	5%		
CSW stamp row	1	6%	-	-		
<b>Decorative Cord Type</b>						
plied	182	90%	25	10%	41%	41%
replied	232	88%	35	12%	51%	51%
cord diameter	41	2.3	5.6	135	1.82-2.05	.46-.54
cord spacing	38	2.6	68	134	1.16-1.76	.60-1.17

\* vertical elements; differs from Middle Rim Decor  
 # includes countered cords  
 # includes grouped (paired, tripled, quadrupled) cords



Table 3.14 (cont.)

Loseke Ware Central Des Moines R. Valley n = 16 (Benn & Rogers 1985: Table B.3)			Loseke Ware Western Iowa n=29 (Benn et al n.d.: Table 3.9) (Benn 1982: Table 8)			Lane Farm Cord Impressed n=51 (Benn 1978:275)					
n	% - metrics		n	% - metrics		n	% - metrics				
13	87%		6	67%		23	49%				
2	13%		3	33%		23	49%				
-	-		-	-		1	2%				
3	20%		9	39%		10	20%				
12	80%		14	61%		41	80%				
-	-		1/23	4%		6/45	13%				
-	-		2	18%		10	21%				
6	50%		8	73%		25	53%				
6	50%		1	9%		12	25%				
<hr/>											
15	94%		22	85%		51	100%				
2	6%		4	15%		-	-				
<hr/>											
	$\bar{x}$	s		$\bar{x}$ ranges	s		$\bar{x}$ ranges	s			
15	4.1	.8	9	4.7-4.8	-	47	3.4-3.9	.59-1.27			
16	5.6	1.1	27	5.4-6.2	.5-1.1	50	6.3-6.6	1.10-1.24			
	1.5	-	-	.7-1.4	-	47	2.9-3.6	-			
<hr/>											
14	93%		5	56%		38	81%				
1	7%		1 obl	11%		2	4%				
-	-		1 cws cord	33%		7	15%				
<hr/>											
9	69%		9	100%		6	13%				
4	31%		-	-		41	87%				
<hr/>											
9	69%		10	100%		40	85%				
4	31%		-	-		7	15%				
<hr/>											
-	-		-	-		3	6%				
-	-		-	-		1	2%				
12	75%		26	93%		32	64%				
-	-		1	4%		1	2%				
2	12%		1	4%		6	12%				
-	-		-	-		1	2%				
2	12%		-	-		4	8%				
-	-		-	-		-	-				
-	-		-	-		1	2%				
-	-		-	-		-	-				
3/3	100%		8/14	57%		18/25	72%				
-	-		-	-		2	11%				
-	-		1	12%		10	56%				
-	-		3	38%		-	-				
-	-		2	25%		4	22%				
-	-		-	-		-	-				
-	-		-	-		2	11%				
3	-		1	12%		-	-				
-	-		1	12%		-	-				
<hr/>											
	$\bar{x}$	s		$\bar{x}$	s		$\bar{x}$	s			
12	30%	75-70%	62%	112-69%	55	31%	59%	292-76%	95-24%	76%	
22	33%	45-67%	38%	102-91%	15-9%	41%	82-67%	45-33%	33%	24%	
16	-	1.2	5	25	1.8	1.9	.3-4	46	1.6	1.8	42-56
				25	2.0	2.9	9-11	45	2.4	3.0	1.18-1.44

Table 3.15  
Ceramic Ware Stratigraphy  
13LA38

Sherd Numbers

Stratum level	Late Woodland		Weaver & Linn	Baehr/ Pike	Havana	Morton	Liverpool	Marion
	CI	bs.						
I	1	3 24			1			
	2	9 78	2		1			
	3	7 95	3		2			
	4	12 92	4	1	4			1
	5	2 48	5		2		4	
II	6	6 29	6		4		6	
	7	4 5	6	1	10	5	5	1
	8	1 1	7	2	13	2	7	
	9	1 1	1	1	4	1	11	1
fea		7	2	24				
III	10				8	4	3	
	11						2	

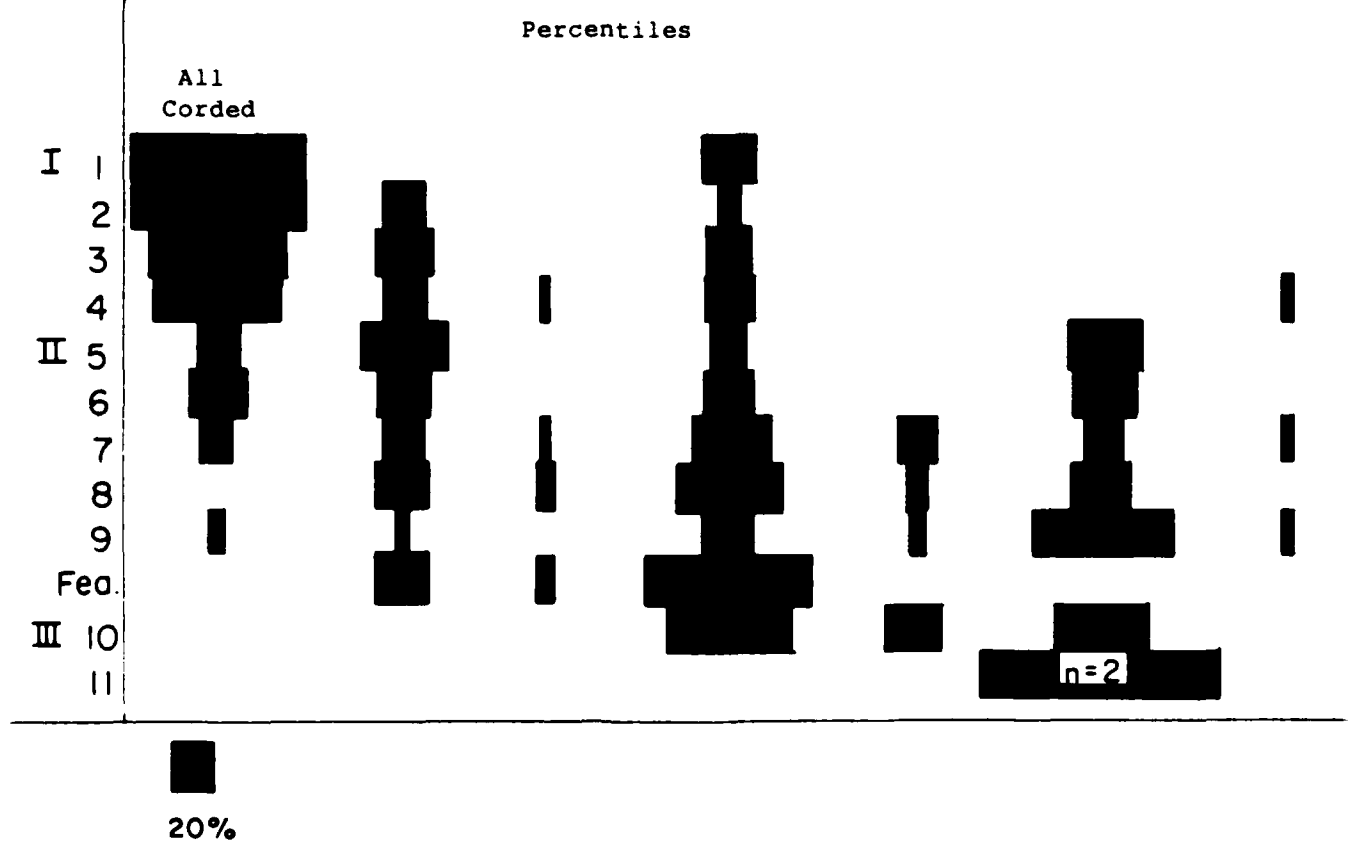

IU  
LITHIC ANALYSIS

by David G. Stanley & Arthur Hoppin  
Highland Cultural Research Center

This analysis focuses on the lithic assemblage recovered from 13LA38 (Sand Run). The discussion and tabular material are organized according to the three excavation blocks and three cultural/natural strata. Stratum I contains the late Late Woodland and portions of the early Late Woodland. The Early and Middle Woodland and the rest of the early Late Woodland deposits are in Stratum II. Stratum III includes the Late Archaic.

The thrust of this analysis is to conduct a detailed examination of the artifact classes that best represents site 13LA38 as a whole yet recognizes differences related to cultural association and geological context. Implicit in the analytical approach is the assumption that assemblages represent a sequence of logical steps, including the reduction of raw nodules to cores, then to flake blanks or core tools, then preforms, then finished tools, and inclusive of the production of all types of flakes during every step. Each specimen which represents a stage in the lithic reduction sequence could have been used as a tool.

There are a wide variety of techniques and approaches in stone tool manufacture that produce tools with essentially the same function. The impetus behind these individual decisions to utilize one approach instead of another may be the direct result of the general constraints of raw material, or the decision may relate to other cultural factors.

The intent of this analysis is to produce data which can be viewed in relation to three archeological issues:

1. **Function:** This category consists of attributes related to use, such as morphology (size, edge angle, shape, etc.) and use-wear (edge damage, polish, etc.). Use-wear variables were not recorded individually. However, each tool was examined beneath a x20 Baush and Lomb binocular microscope, and functional determinations (e.g. graver, cutting or scraping knife, perforator, etc) were based on use-wear variables outlined by a number of researchers (Semenov 1964; Hayden ed. 1979; Odell and Odell-Vereecken 1979; Keeley 1980). Recorded morphological variables not only contribute greatly towards functional determinations but also give information relating to technological aspects of stone tool manufacture.
2. **Technology:** This category consists of attributes relating to the manufacture of stone tools (detachment techniques,

platform types, raw material type, heat treatment, size, shape, etc.). The technological characteristics utilized for this analysis borrow from those outlined by Honea (1965), White (1968) and Callahan (1979).

3. Culture: These are the functional and technological characteristics related to or the result of cultural characteristics, i.e. the passing of knowledge from generation to generation in order to maintain social and biological reproduction. Cultural decisions are not the result of available raw materials and the task at hand. A key cultural feature may be the choice between alternative technological approaches which might all produce a tool that serves the same function. The main difference between approaches is the length of time and effort expended to achieve the same result.

### Methodology

Because of limited time and money, an in depth use-wear analysis was not conducted. However, tool types, especially flake tools, were defined on the basis of wear patterns as well as morphological characteristics. Tool types are defined using use-wear criteria developed by several researchers (Semenov 1964; Hayden, ed. 1979; Keeley 1980; Odell and Odell-Vereecken 1980). Use-wear and morphological attributes are defined in Appendix D. Technological characteristics include a variety of terms developed from the work of several researchers, including Honea 1965; Movius et al. 1968; White 1968; Callahan 1979). Attribute definitions are available in Appendix D.

Lithic debitage was recorded by provenience (1X1m square). Each specimen was examined and identified individually according to flake type. Technological characteristics were noted (e.g. heat treatment, platform type, flake morphology, detachment technique) as were raw material types and breakage.

Cores and tools were separated from the debitage at the initial sorting stage of the analysis. Tool types were categorized on the basis of technology, function, and the presence or absence of diagnostic characteristics (e.g. hafted bifaces). Each tool and core was identified and individually grouped according to type (i.e. double-platform core, pyramidal core, etc. or flake tool, drill, blade, projectile point, etc.).

### Lithic Debitage and Cores

A total of 6,465 pieces of lithic debitage was recovered from 13LA38. This total represents 87% of the entire chert assemblage. The debitage recovered during the flotation process (281 items) has not been included in this analysis. Debitage recovered from the features total 507 specimens. The remaining

6,184 pieces were recovered from the excavation levels and have been tabulated by individual blocks within each stratum (Tables 4.1-4.7). Eight basic characteristics were documented for each specimen. These characteristics, totalling 35 variables, are:

1. Flake type
2. Condition
3. Type of striking platform
4. The detachment technique
5. Shape of the artifact
6. Flake proportions
7. Raw material

Each variable was totalled and the percentage was figured in relation to the excavation blocks and the three main strata. There is some variability between blocks, but this discussion will focus on the relationships between strata.

Table 4.1 illustrates the relationship between the excavation blocks in Stratum I. There are 1,998 specimens, and "secondary thinning flake" is the most numerous flake type. This type represents 29-40% of the individual block totals and 33% of the debitage recovered from Stratum I.

The next most numerous flake type is angular shatter and the catch-all category of flake fragments. Both of these types retain an 18% share of the overall totals and range from 10-20% in the individual blocks. Decortication flakes are rare. Together primary and secondary decortication flakes represent less than 6% of the total. Interior flakes are equally low at 9%. Flakes deemed large enough for flake blanks (suitable for manufacturing a tool) consisted of only 3% of the entire sample.

The large proportion of secondary thinning flakes may be explained by the position of this category in the lithic reduction sequence. But, it also indicates that production of secondary bifaces and projectile points was a major activity.

Stratum II totals 1,809 examples with very similar proportion of flake types (Table 4.2). Again, secondary thinning flakes is the most numerous type representing 28% of the overall total. Flake fragments and angular shatter are next at 12% and 19% respectively. However the percentage of decortication flakes rises considerably. Primary decortication flakes constitute 2% of the total, and secondary decortication flakes increases to 14%. The increase in decortication flakes may be directly related to the use of Warsaw tabular chert to manufacture bifacial tools during the Stratum II occupations. But, the general increase in decortication flakes is also noticeable for Burlington chert.

Stratum III contained 1,870 pieces of debitage of which only 4 examples are from Block A and 407 are from Block B (Table 4.4). As with Strata I and II, the secondary thinning flake (26%) is

the most numerous type, followed by flake fragments (15%) and angular shatter (18%). Secondary decortication flakes dropped to 11%, slightly lower than Stratum II but still over twice the percentage in Stratum I. Primary decortication flakes increased to their largest share at 4%.

It is notable that the percentage of secondary thinning decreases from 33% in Stratum I to 28% in Stratum II and 26% in Stratum III. This decrease occurs as the percentage of decortication flakes rises from Stratum I (6%) to 16% in Stratum II and 15% in Stratum III. These percentage changes may not be dramatic (the variation between blocks is similar), but they are consistent (Table 4.6).

The condition of the flakes from each stratum is very consistent. The whole specimens ranged from 44-46% of the totals, with the next largest percentage consisting of unidentifiable fragments (29-32%). Distal and proximal fragments varied from 4-12%, and medial fragments represent the remaining examples (1-6%).

Although there is little deviation of flake type percentages between strata, there are differences in regard to technology (Table 4.6). The most numerous type of striking platform is unafaceted, but this type is only 42% in Stratum I. Other platform types, such as faceted (10%), dihedral (16%) and edge faceting (3%), also occur (Table 4.1) and indicate platform preparation. The second most numerous platform from Stratum I is pseudo-faceted (24%). This category consists of all specimens which suffered sufficient damage from the force of application to destroy all evidence of a striking platform, yet not break the flake itself.

There is a big increase of unafaceted striking platforms in Stratum II (Table 4.2) as the proportion increases to 68%. The use of this platform type increases in Stratum III as well, representing 75% of the total. The increase of unafaceted platforms reflects a decrease in the use of the platform types associated with preparation. Pseudo-faceted types total 22% in Stratum II and 17% in Stratum III.

The reason for these technological changes associated with striking platforms is evident when one examines the detachment techniques that were utilized (Table 4.6). In Stratum I softhammer percussion is the dominant detachment technique, occurring 72% of the time. Hardhammer percussion is evident only on 28% of the observable specimens. This is not the case in Stratum II, where hardhammer percussion occurs 65% of the time and softhammer percussion is used on only 34% of the examples. This trend is also evident in Stratum III.

This change in technology is also evident in viewing flake morphology and proportions (Table 4.6). In Stratum I expanding flakes occur 62% of the time, with contracting and parallel

flakes totalling 19% each. In Stratum II expanding flakes drop to 26%, contracting flakes increase to 53%, and parallel flakes remain steady at 20%. This trend is also apparent in stratum III: expanding flakes decrease to 25%, contracting flakes increase to 66% and parallel flakes drop to 9%.

Flake proportions also change. End flakes (those longer than they are wide) represent 45% of the specimens in Stratum I. Side flakes (those which are wider than they are long) are 55%. In Stratum II, end flakes increase to 77%, and side flakes decrease to 23%. As with the other technological characteristics this change is also present in Stratum III, with end flakes totalling 67% and side flakes 33%.

The results of the debitage analysis indicate a substantial change in lithic technology (i.e. in the use of softhammer techniques) between Stratum I and the two lower strata. The debitage reveals a technological continuum between Stratum II and Stratum III.

The limited number of decortication flakes in Stratum I suggests the use of prepared cores, obtained and trimmed elsewhere. Although there is an increase in decortication flakes in Strata II and III, it is likely that prepared cores were also brought from elsewhere after being trimmed. The larger number of decortication flakes in Strata II and III may indicate larger cores were being used.

Table 4.8 illustrates the core types and their weights. A total of 117 cores were recovered from 13LA38. Of this total 31 examples were from Stratum I, 38 from Stratum II, and 48 from Stratum III. It is difficult to examine these artifacts statistically because of the limited sample size per core type. However, some general observations can be made.

Two specific core types, double platform and pyramidal, occur throughout all three strata. Double platform cores tend to cluster in Stratum I (7) and Stratum III (11), with only 3 specimens from Stratum II. Pyramidal cores cluster in a similar manner: 8 examples in Stratum I, 5 in Stratum III and 3 in Stratum II.

Strata I and II do have single platform cores in common, with 2 and 3 specimens respectively being present. This type of core does not appear in Stratum III. Discoidal cores occur only in Stratum I (3) as do 3 of the 4 tested cobbles. The tested cobbles are small stream rolled nodules. All five of the exhausted cores are from Stratum III.

The largest cores (Table 4.8) weigh over 80 grams. There are 18 specimens in this category: 13 from Stratum III, 2 from Stratum I and 3 from Stratum II. The smallest cores weigh less than 25 grams and total 42 specimens. Fifteen are from Stratum I, 20 from Stratum II and only 7 from Stratum III.

Probably the most distinctive characteristic of the cores from Stratum I is their small size (Table 4.3). Only 2 (6%) specimens weigh over 80 grams, and 24 (77%) weigh less than 50 grams. This characteristic would seem to suggest that Late Woodland cultures made smaller tools from smaller cores than cultures of the preceding periods.

### Flake Tools

To accurately interpret the debitage and core data, one must also take a detailed look at a tool types. Flake tools often are treated as debitage and not given a close examination. Flake tools (other than blades) retain a significant position in the lithic reduction sequence and are closely related to the the debitage and core artifact types. Most of these tools, but certainly not all of them, were manufactured by detaching flakes from cores in a manner similar to the general debitage.

There are 3 categories of flake tools. Unhafted flake tools occur throughout all 3 strata (Tables 4.9, 4.11, 4.13, 4.15). Hafted flake tools are present only in Stratum I. Most blades are in Stratum II, although several specimens occur in Stratum III.

#### Unhafted Flake Tools: N=474

Unhafted flake tools have little or no modification and consist of flake blanks representing any of the stages of the lithic reduction sequence as well as shatter or natural flakes. Flake blanks may have been detached by pressure, hard-, or softhammer percussion and appear to have been hand-held. Some of the unhafted flake tools have been retouched, and all show evidence of use. Specific tool types within the unhafted flake tool category are determined by the general morphology and specific wear patterns (i.e. wear orientation, types of flake scars, polish, edge angle and configuration, etc.). Over 90% of the unhafted flake tools were used as knives in either a scraping or cutting motion (Tables 4.10, 4.12, 4.14).

Interior flakes dominate the unhafted flake tools in Stratum I (52%). The large number of unhafted flake tools explains the small sample of flake blanks of all types present in the general debitage. Decortication flakes represent 15% of the blanks, while secondary thinning flakes constituted 12% and primary thinning flakes 8%. The remaining specimens consisted of flake fragments and shatter.

In Stratum II unhafted flake tools made from interior flakes are still the most numerous at 34%, but there are increases in secondary decortication flakes to 21% and primary decortication flakes to 8%. This trend continues in Stratum III as secondary decortication flakes become the most numerous at 30%, interior



flakes decrease to 19% and primary decortication flakes represent only 6%. Secondary and primary thinning flakes also show an increase in use as unhafted flake tools in Strata II and III

From a technological perspective unhafted flake tools from Stratum I have a similar proportion of platform types as the debitage. Unfaceted platforms total 45%, and prepared platforms combine for 34% of unhafted flake tool sample. There is a considerable difference in the detachment techniques, however. The general debitage from Stratum I was detached by softhammer percussion 71% of the time, but softhammer was used only 37% of the time to detach flake tool blanks. Hardhammer detachment reflects a similar relationship and was used 63% of the time to detach flake tool blanks but only 28% to detach the debitage.

The unhafted flake tools from Strata I and II that were detached from cores by hardhammer percussion total 72%. Those detached by softhammer percussion represent 28% of the total. There is distinct increase of pseudo-faceted platforms on the unhafted flake tools from Strata I and II. Platform damage of this nature occurs on only 20% of the specimens from Stratum I, but increases to 32% of the time in Stratum II and 37% in Stratum III. The opposite is true for the debitage as pseudo-platforms decrease from 24% in Stratum I to 17% in Stratum III.

The striking platforms on the unhafted flake tools from Strata II and III are unfaceted only 38% and 36% of time respectively, but platform preparation is evident on 15% and 27% of the examples respectively. The latter figure, taken from the Stratum III specimens, includes the occurrence of edge grinding on 20% of the total sample. Edge grinding was not observed on a single example of the Stratum III debitage.

Evidence of heat treatment in Stratum I was present on only 10% of the debitage but was present on 26% of the unhafted flake tools. Heat treated debitage from Stratum II occurred 11% of the time, and heat treated unhafted tools occur 13%. The Stratum III heat treated debitage represents only 8% of the sample but 17% of the unhafted tools.

End flakes were preferred over side flakes in Stratum I by 62% to 38% respectively. The opposite was true in Stratum II and Stratum III with side flakes being preferred over end flakes by 53% to 47% and 72% to 28% margin respectively. This preference of side flakes over end flakes may help support the suggestion of a technological continuum between Strata II and III with an abrupt change occurring in Stratum I.

The most common unhafted flake tool type were knives. These knives were used for both cutting and scraping, although one may occur without evidence of the other. Only one spokeshave and one hide scraper were present, both in Block C. The remaining tool type consisted of 7 perforators (Figure 4.1d). All but one were found in Block C.

Although all of the unhafted flake tools had evidence of use or retouch, less than 40% of the specimens actually were broken. The mean size of unhafted flake tools are almost identical for Strata I and II. The length is 3.0cm, the width 2.6cm, and the thickness is .6cm. The mean edge angle is slightly higher in Stratum I at 39 degrees than the Stratum II mean edge angle (36 degrees). The mean size of unhafted flake tools from Stratum III is somewhat larger with a 3.3cm length, 2.9cm width, and .7cm thickness. The mean edge angle is much higher (45 degrees) than those in Stratum I and II.

Hafted Flake Tools: N=18

The second category of flake tools consists of hafted specimens. This category tends to be restricted to end flakes produced by softhammer percussion that fit in the typological category of secondary thinning flakes. Some specimens may have cortex on their dorsal surfaces. Unlike their unhafted counterparts, none of the hafted tools have been retouched. However, 12 of the 18 specimens had distinctive evidence of platform preparation prior to detachment of the flake blank.

Unhafted flake tools are somewhat larger than hafted flakes. The former were generally detached by hardhammer percussion and decortication, and interior flake blanks were preferred. Unhafted flake tools are somewhat wider and are twice thick as hafted flake tools (Tables 4.16-4.19). Both flake tool types from Stratum I were heat treated 26% of the time, over twice the percentage of the heat treated debitage.

Tables 4.19 and 4.20 document the characteristics associated with hafted flake tools. A total of 18 specimens are from Stratum I (Figure 4.1c): one from Block A, 3 from Block B, and 14 from Block C. Since the sample size is so small (less than 20), percentages were not calculated for this tool category. It was felt comparisons between strata as well as other tool categories would not be accurate.

Only one of the hafted flake tools has evidence of cortex. All were detached by soft-hammer and have relatively high platform angles (greater than 65 degrees) unlike standard secondary thinning flakes, which have relatively low platform angles (less than 65 degrees). Two specimens were expanding flakes, while the rest were parallel (5) or contracting (7) flakes. All but 3 represent varieties of Burlington Chert. Almost a third of the specimens (5) are heat treated

The majority platform type is continuous faceting (6). Four other hafted flake tools have evidence of platform preparation: one dihedral, 2 edge faceted and one double-faceted platform. There are 3 unfaceted platforms and the remainder were pseudo-faceted. Grinding occurred on 4 specimens.

The most distinctive characteristic of the hafted flake tools is, of course, evidence of hafting. Very small notches (1-2mm) occurred on 3 specimens. On two specimens the notches were created by the removal of a single tiny notch flake. These notches are on lateral edges approximately 3mm from the proximal end (base). The third specimen has a single lateral notch on the right edge created by the removal of 3-4 pressure flakes.

Ten of the hafted flake tools have stemmed bases. The stems are contracting, generally contoured to the configuration of the flake blank by pressure flaking or lateral grinding. Included in this category are flake blanks which were not altered but do have evidence of hafting as indicated by slight edge rounding and/or a dull polish of the type associated with use on dried leather (Hayden ed. 1979; Keeley 1980). This type of wear is located on the lower lateral edges and/or the proximal end. Some specimens are altered either by grinding or limited pressure flaking or both. The hafting attributes of all of these tools are on the proximal ends of the flake blanks, the thickest end because of the bulb of percussion.

Four of the hafted flakes functioned as perforators, and 14 were used as knives for cutting or scraping relatively soft materials. The edge angles are very low, ranging from 20-22 degrees.

Two the hafted flake tools are made of Burlington fossiliferous chert. This chert type is very limited in relation to the overall lithic assemblage from Stratum I, representing less than 1%. However, there is a Mills projectile point and a large primary bifacial digging tool made of Burlington fossiliferous chert identical in color and texture to the hafted flake tools.

Blades: N=128

Blades are distinctive tool types that are associated with specific prehistoric cultures world wide. In the North American Midwest they are generally associated with the Middle Woodland period (White 1968). Blades are defined as being at least twice as long as they are wide with more or less parallel sides (Honea 1965; Movius et al. 1968;) However, blade-like flakes occur in almost any lithic assemblage. Consequently, the use of the term "blade" needs to be restricted to "the products of a systematic flaking technique" (White 1963). Cores and striking platforms are prepared in such a manner as to produce the maximum number of blades.

The point of impact of the percussion tool on the platform was determined by a careful preparation which consisted in trimming the ridges left by previously detached bladelets (White 1968:21)

Other blade attributes include triangular and trapezoidal cross-sections, and medial ridges on the dorsal surface that indicate prior removal of previous blades. Generally, blades with triangular cross-sections have one medial ridge, while those with trapezoidal cross-sections have two.

In many cases blades may be used directly as tools, or they may be modified into specific tool types. The blades and hafted tools may be related from a technological and functional standpoint, and possibly from a cultural perspective as well. Blade-like tools are included in the hafted flake tool category from Stratum I, but these do not have the distinctive characteristics associated with blade production. However, hafting characteristics are similar.

There were a total of 121 blades recovered from Stratum II and 7 specimens from Stratum III (Table 4.21; Figure 4.2). Block A Stratum II contained 14 examples. Block B Stratum II produced 65 blades, 47 of which came from features. Forty-two specimens are from Block C Stratum II.

Two blade cores were also recovered, both from level 7 but in separate blocks, B and C. The first specimen is a relatively thin discoidal core (Figure 4.3c). The inner surface served as the striking platform and was manufactured by removing 3 lamellar flakes that extended the length of the core creating two ridges. Blades were removed from the entire circumference of the core by softhammer percussion, with the distal ends of the negative scars meeting in the center of the outer surface. Platform preparation, in the form of edge faceting, is evident along the platform edge. This specimen is made of a fine grain gray Burlington chert and does not appear to have been heat treated.

The second blade core is a polymorphic core with numerous striking platforms, some of which display edge faceting (Figure 4.3b). This specimen retains some cortical surfaces and is made of heat treated fine grain white and gray Burlington chert. Both specimens are small. The discoidal core weighs 39 grams, and the polymorphic core is 54 grams.

Table 4.21 illustrates the characteristics associated with the blade tool industry from 13LA38. Parallel sided flakes occur most often and represent 52% of the total. Contracting flakes total 26% and expanding flakes 18%. Decortication flakes are present and consist of 12% of the total. The remaining 88% are interior flakes.

Only 19% of the blades had unfaceted platforms, although edge grinding was evident on many of the unfaceted platforms. Edge grinding occurred on 36% of the blades, edge faceting totals 30%, multi-faceted 8%, single flake facet 2%, dihedral 5%, and pseudo-faceted represents 21%. Detachment was primarily by softhammer percussion (92%), although hardhammer percussion is evident on 4%. Only one blade appeared to have been detached

with the aid of an anvil. It has two bulbs of percussion (i.e. bipolar). Three specimens had backing, and only 6 have been retouched.

Almost half (44%) of the dorsal surfaces on blades have a single ridge. Thirty specimens (23%) have double ridges, and 3 had triple ridges (2%). Twenty-two examples (17%) have Y-shaped dorsal surfaces, where two longer flake scars, initially separated by a shorter scar, merge toward the distal end of the blade. Two other types of dorsal surfaces were noted. The X-shape surfaces have two negative flake scars with distal ends that meet in the center of the blades's dorsal face and are flanked on either side by full length scars. This type of face may indicate the use of double-platform blade cores. There are 8 specimens of this nature (6% of the total). The final type of dorsal surface is V-shaped similar to the Y-shape, except the negative flake scar in the center extends the length of the blade tool. There are only 3 examples of this type in the collection.

Over half of the blades appear to have been hafted (54%). For the most part the hafting element consists of a contracting stem that measures between .5 and 1.0cm in length. The stems are usually shaped by pressure flaking or lateral grinding. Only 2 specimens have hafting elements created by notching. Another indication of hafting is the occurrence of bulbar thinning. Although softhammer bulbs of percussion are generally diffuse, they may be too thick for some hafting styles. Fourteen examples (11%) have evidence of bulbar thinning, which generally was accomplished by removing one or 2 pressure flakes. All but 2 of the hafted blades use the proximal end for the hafting element. The other two are hafted on the distal end. The mean size of the blades is 3.4cm long, 1.6cm wide, and .4cm thick (Table 4.22). The edge angles were all very low, all being less than 25 degrees.

Only 23 specimens (18%) have no evidence of use-wear. For the most part, blades functioned in a manner very similar to the unhafted and hafted flake tools. Over 70% of them were used as knives in cutting and scraping motions on soft or moderately hard materials. The low edge angles and sharp edges probably were ideal for delicate tasks that require precision cutting or scraping. Six specimens functioned as drills and closely resemble the simple drills described by White (1968). Six other blades had graver spurs, 2 may have been used as spokeshaves and one was a perforator.

The blade industry at 13LA38 raises the nagging question of why go to all the time and trouble to produce this specific type of tool when unhafted flake tools, or even debitage, are readily available and certainly less time consuming to produce.

### Chipped Stone Tools: Stratum I

A total of 67 chipped stone tools was recovered from Stratum I, 22 of which are classified as projectile points. The other 45 tools are categorized as drills, bifaces, or unifaces. The chipped stone tool types are based on the characteristics outlined in Appendix A. The most distinctive characters are technological, such as hafting (notching, constriction, grinding), and the degree of flaking (i.e. primary, secondary, tertiary, initial edging). Functional and morphological attributes also were used to identify tool types.

#### Unifacial Chipped Stone Tools: N=4

There is only one secondary uniface in the chipped stone tool collection from Stratum I. This specimen is from Block B. This distal fragment is small (1.9cm wide, .8cm thick) with a transverse break. It has a plano-triangular cross-section. The dorsal surface was shaped by lamellar softhammer flaking resulting in flake scars which merge along a central ridge. The lateral edges are straight, but the distal end has been formed into a point and appears to have been used as a graver or perforator.

There are 3 primary unifaces were in Block C. One specimen is whole and has a blunt ovate shape. It measures 6.1cm long, 3.4cm wide and 1.9cm thick. The edge angle is very steep (63 degrees). The second specimen is broken transversely but measures 3.2cm wide and 1.5cm thick. It also has a steep edge angle (58 degrees). Both of these tools are multi-functional. They were initially pyramidal cores and were shaped by expanding hardhammer flaking except for the graver spurs on the distal ends. These spurs were constructed by detaching short expanding pressure flakes. The lateral margins of the tools were used as spokeshaves.

The final specimen is a flat tabular artifact which measures 4.7cm long, 3.0cm wide and 1.4cm thick. Unlike the others it has a relatively low edge angle (33 degrees) and probably functioned as a knife. A flat cortical surface directly opposite the working edge served as backing. The flaked surface was formed by expanding hardhammer flaking. Some of the flakes hinged in the center of the tool, which is somewhat thicker. This may have been an accident, but by the same token the thickened center adds to the durability of the tool. This specimen initially may have been a single-platform tabular core.

Unifacial tool types of this nature suggest that specific core types are designed for functions that go beyond flake blank production. This may explain why some core types were preferred over others.

Initially Edged Bifaces: N=3

There is one fragment from Block A which fits in this category. It appears to be a portion of a longitudinal edge and is relatively thick. Both faces of the flake blank edge were thinned by expanding softhammer flaking and pressure flaking. Two other initial biface fragments were from Block C. These specimens, a small medial fragment and another almost whole piece minus the distal tip, are small, relatively thin (.4cm, .6cm) tools shaped by short expanding softhammer flaking.

Primary Bifaces: N=10 (Figure 4.4b)

Block A contains one primary biface fragment. It is a longitudinal edge fragment with expanding hardhammer flake scars. A snap fracture suggests this tool may have been used as wedge. Edge wear is moderate, however.

There are 2 primary biface fragments from Block B. One is a longitudinal fragment, and the other appears to be a hoe or digging tool. The latter item consists of the distal and medial portion of a large rectangular primary biface. It is 7.5cm long, 5.1cm wide at the bit and 4.8 at the opposite end, and is 1.7cm thick. The entire dorsal face was thinned by the removal of several large shallow expanding softhammer flakes. The ventral face was thinned by detaching numerous smaller expanding flakes along the lateral margins leaving a portion of the original surface. Both faces have evidence of short, expanding and lamellar softhammer flaking along the lateral margins. The bit was formed by using the ventral face as a striking platform and removing several large expanding flakes to create a concave shape to the dorsal face. The convex bit was thinned by removing a series of short expanding softhammer flake from both faces. It was resharpened unifacially by using the ventral face as a striking platform. This technique also helped maintain the concave shape of the dorsal surface. The edge angles range from 30 degrees at the bit to 48 degrees on the lateral edges. Extensive polish and edge rounding suggests this tool may have functioned as a hoe or digging tool. It is made of Burlington fossiliferous chert, as is the Mills projectile point and several hafted flake tools from Stratum I.

There are 7 primary bifaces from Block C. One specimen is a longitudinal fragment, and two others are corner fragments. Two of these fragments were shaped by expanding softhammer flaking and the third by lamellar softhammer flaking.

The fourth specimen from Block C is whole. It is an ovoid medium-sized biface with a biconvex cross-section and is 5.2cm long, 3.2cm wide and 2cm thick. This tool is relatively thick for its overall dimensions, yet there was no attempt to thin it. It was formed by softhammer flaking of shallow lamellar and expanding flake scars that meet along a central ridge but left a

small portion of the original surface at the thickest area of the tool. The edge angles are relatively thick, ranging from 42 degrees along the working edge to 70 degrees along the backing. It does not appear to have been hafted. The edge damage consists of intensive rounding and abrasion. Bright polish on the dorsal face suggests that this specimen is a woodworking tool. One of the lateral margins and the two ends do not have evidence of wear, and intensive edge grinding may represent backing.

The fifth specimen has a blunt ovate shape, a plano-convex cross-section and measures 4.3cm long, 3.1cm wide and 1.7cm thick. It resembles the preceding specimen and probably was hafted. The hafted portion of the tool is .3cm thinner than the bit and is 2cm long. It was thinned by lamellar softhammer flaking on the ventral surface only. These flakes are step terminated at the midpoint of the tool, suggesting this point represents the limits of the hafted portion. The rest of the tool, including the dorsal surface of the hafting element, was thinned by expanding hardhammer flaking. The bit was re-sharpened by lamellar softhammer flaking. The use-wear consists of edge crushing and rounding. This specimen appears to have been a digging tool.

The sixth specimen also was hafted. It is broken transversely, and the distal portion of the blade is missing. The hafting element is a parallel-sided stem with a straight base and is 1.0cm long, 1.9cm wide and .8cm thick. The blade shoulders are 2.7cm wide and 1.0cm thick. The haft was manufactured by removing two steep expanding hardhammer flakes, one from each lower lateral margin. The ventral surface was used as the striking platform. The base was thinned and straightened by short expanding softhammer flaking. The triangular blade was thinned and formed by short expanding hardhammer flaking. This tool may have functioned as knife.

The final specimen from Block C is the proximal end of a discoidal shaped primary biface with a transverse break and biconvex cross-section. One surface was thinned by the removal of large shallow lamellar flakes by softhammer percussion. The opposite face was thinned by removing short expanding softhammer flakes, leaving a portion of the original surface in the center of the tool. This primary biface may have functioned as digging tool. It appears to have been hafted. The haft element was manufactured by bifacial pressure flaking which created small notches isolating a .7cm long stem from the rest of the tool. The base is slightly convex with a rounded edge. Portions of the left lateral edge on the blade have extensive edge rounding. The distal portion of the blade is missing.



Secondary Bifaces: N=14 (Figure 4.4c)

There are 6 secondary bifaces from Block A. One specimen is whole, 2 are small distal fragments, 2 are unidentifiable and the final specimen is missing only the base. The four fragments are not discussed.

The large triangular specimen from Block A has parallel lateral edges and convex end and is broken transversely. This specimen, shaped by lamellar and expanding softhammer flaking, is relatively thin (.7cm) and narrow (2.0cm) with a biconvex cross-section. The edges are heavily battered and rounded, suggesting extensive use. This specimen may represent the blade portion of a projectile point but appears to have functioned as a knife.

The whole specimen from Block A may have been a digging tool (Figure 4.4a). It is a longitudinally edged secondary biface which is whole except for an oblique break on a portion of the proximal (hafted ?) end. It measures 7.8cm long, 3.6cm wide, 1.2cm thick, and has a ovoid shape with a convex distal end and relatively parallel lateral edges. The tool was formed by transverse expanding softhammer secondary flaking and expanding softhammer tertiary flaking. The cross-section is biconvex. Edge damage includes rounding and a dull polish on the proximal end. This type of edge damage is not evident anywhere else on the tool. However, crushed edges and tiny step terminated flake scars along the lateral edges and distal end are evident. Edge angles are relatively low ranging from 30-40 degrees. The most interesting characteristic of this tool is that the proximal one-half of the tool is much thinner (.8cm) than the distal one-half (1.3cm). I suspect this difference is attributed to the hafting style.

Block B contained one secondary biface and the distal fragment of a triangular blade.

There are 7 specimens from Block C. Two are longitudinal fragments, one is a distal fragment, 3 are medial fragments, the and final specimen is a corner fragment.

Drills: N=12 (Figure 4.1b)

There are 7 specimens in this tool class from Block A and 5 from Block C. Three separate types are represented.

The first type consists of winged drills which have expanding bases, very narrow bits, and steep bitriangular cross-sections. There is at least one specimen in this category and possibly 3 others, all of which are broken transversely. Three are made of Burlington chert, and the fourth is Warsaw chert. Two represent distal ends, one is a proximal end, and the remaining drill is a medial fragment. All 4 are made of

Burlington chert, and one specimen is heat treated. The use-wear on 3 of these specimens consists of heavily crushed and battered edges, whereas the fourth specimen has very smooth and rounded edges. Wear differences indicate these tools were not used on the same raw material. They range in thickness from .5-.8cm.

Block C contains one whole winged drill, which is in two pieces. It also has a steep bitriangular cross-section with a thickened proximal end.

The second category of drills are similar to the simple or double-backed drills described by White (1968:88) and associated with the blade industry of the Middle Woodland period. The specimens from Block A, however, do not appear to be constructed on blades and have some characteristics not compatible with White's descriptions. All three of these drills are made of Burlington chert, and one is heat treated. There are 3 specimens in this category. They have biconvex or plano-convex cross-sections and are much flatter than the winged drills. They lack expanding proximal ends. Two specimens are whole. The broken drill consists of the distal portion of a tool. It is relatively flat and wide (1.5cm) but is about the same thickness as other specimens (.5cm). This tool is shaped by pressure flaking only along the lateral margins. The original flake blank surfaces are visible on both faces. Bifacial edge crushing occurs on both lateral edges and the distal end.

Both of the whole drills were bifacially thinned using secondary softhammer flaking to form isosceles triangles. One specimen was constructed on a lamellar secondary thinning flake blank. Both specimens are 3.5cm long, 1.0cm wide, and .5cm thick. The ventral face of the first specimen was thinned by removing 4 transverse expanding flakes. A similar approach was taken on the dorsal face, but the flakes did not extend the width of the dorsal surface, leaving a flat, planar surface on the lower left lateral edge. The dorsal portion of the right lateral edge was retouched by steep pressure flaking leaving shallow lamellar flake scars. This area may have been utilized as a knife in a scraping motion. Extensive edge damage on the lower lateral margins and the distal end indicate use as a drill as well.

The second specimen was manufactured by using softhammer percussion to remove broad, shallow expanding flakes which met along a central ridge. Steep, continuous pressure flaking was used to maintain a working edge.

The use-wear suggests that both of these drills were used to bore holes approximately .9cm in diameter. It also appears that the proximal end was hafted. The effort to thin the bulbs of percussion and striking platforms of the original flake blanks suggests these tools may have been hafted by insertion in a handle.

The third drill category consists of flat bifacial drills with wide bits. There are one whole specimen and 2 medial fragments from Block C. The bits on these tools range from 1.4-1.7cm in width. The whole specimen has a very narrow triangular bit and a squared hafting element. The latter is very thick (1.7cm) and is 2.4cm wide and 1.8cm long. The blade is 3.2cm long, 1.7cm wide and .9cm thick. This drill was shaped by steep expanding softhammer flaking and has a bitriangular cross-section.

The 2 medial fragments have biconvex cross-sections and are relatively thin (.7cm) and wide (1.5,1.7cm). One specimen was thinned by shallow lamellar softhammer flaking that left flake scars meeting along a central ridge. The second specimen was not flaked over the entire surface, but edges were created by steep bifacial pressure flaking.

The remaining drill is an expedient tool which has use-wear evidence indicating it is drill. It is a narrow broken flake with an elongated point (the bit).

Projectile Points: N=23

Four projectile points were found in Block A, 3 in Block B, and 15 specimens are from Block C. Thirteen of the total specimens from Stratum I are whole, 2 are basal fragments, 3 are distal fragments, 2 are proximal fragments, and the remaining 3 are blade fragments.

Ansell Constricted: N=1 (Figure 4.5f)

Description: This projectile point type is described by White (1968:75) as having a subtriangular blade with a convex base. Two lateral indentations placed along the proximal section of the blade edges form an irregular expanding stem. This point style is similar to the Steuben type and is associated with the late Middle Woodland period.

Block A contains one specimen that closely resembles the Ansell constricted point style. It measures 4.9cm long, 2.1cm wide, and .8cm thick and is made on a Burlington chert interior flake blank. It has a plano-convex cross-section that probably was directly related to the initial configuration of the flake blank. The dorsal surface is convex and the ventral is flat. Secondary thinning was accomplished by softhammer percussion, resulting in shallow expanding flake scars that join along a central ridge running the length of the tool. Tertiary flaking is represented by discontinuous softhammer and pressure flaking, resulting in short shallow expanding and lamellar flake scars. The base has a small oblique break on one corner. Use-wear is limited to edge rounding and crushing.

Flake & Madison Points: N=5 (Figure 4.5h)

Description: Four flake points are small, irregularly shaped isosceles triangular points with no notching. These points are constructed by minimal pressure flaking along the lateral margins and by secondary thinning flakes on the original bulb of percussion. The shape of the original flake blank usually determined the overall form of the finished point. The one Madison point has an isosceles triangle shape with a straight base and slightly convex blade (cf. Morrow 1984:80), but otherwise is manufactured in the same manner. These projectile point types have been associated with the late Late Woodland period.

The 4 flake points specimens are from Blocks A and C and T.U. 6 Stratum I, and range in size from 2-3cm long, 1.2-1.5cm wide, and .3-.6cm thick. All are made on Burlington chert, and one specimen is heat treated. One of the flake points is thick and has overlapping types of softhammer retouch as if it were made on a previously broken tool. Another flake point has a single side notch. The flake point type has technological characteristics very similar to the hafted flake tool industry. The Madison point of white Burlington chert is 3.2x1.5x.3cm. It is shaped more carefully on one face with lamellar softhammer secondary flaking and continuous pressure tertiary retouch. The other face has only tertiary edge retouch. The Madison point is from Stratum I Block C.

Haskell Points: N=1 (Figure 4.5d)

Description: Small side-notched point with a concave base. The blade is triangular and the basal ears are lobed or pointed. In Iowa the Haskell type is thought to be related to the Reed type (Morrow 1984:84) and the late Late Woodland period.

The single specimen from Stratum I is from Block C. It was formed by shallow softhammer lamellar flaking. Tertiary flaking is continuous along only one lateral margin and the basal area. It is made of heat treated Burlington chert. It is 2.5cm long, 1.5cm wide, and .6cm thick.

Manker Corner Notched: N=2 (Figure 4.5a)

Description: Manker projectile points are broad, medium-sized corner-notched to stemmed points generally associated with the late Middle Woodland period (White 1968; Morrow 1984). The notches are orientated at a 45 degree angle from the corner of the blade. The blades are relatively thick with convex edges.

The projectile point blade from Block A is triangular with a bi-plano cross-section. It was manufactured by softhammer secondary flaking and continuous tertiary pressure flaking along

one lateral edge. This specimen has a concave transverse break across the neck of the base and an oblique break along a portion of the lateral edge. A small remnant of a corner notch is visible. Secondary thinning flake scars are broad and shallow, meeting along a central ridge. Tertiary flaking left short, very shallow expanding scars. This specimen is 3.1cm wide and .6cm thick. This blade fragment is classified as a Manker point because of the corner notch remnant and is identical to the blade on the following specimen.

Block A also includes a whole Manker Corner Notched point. This specimen, constructed on Warsaw Tabular chert, is 5.0cm long, 3.4cm wide and .7cm thick. The notches are deep (.7cm) and wide (.8cm), and the base is convex. Secondary thinning was achieved by softhammer percussion resulting in shallow, broad expanding flake scars that meet in the center of the blade. Tertiary softhammer flaking is discontinuous with short, shallow expanding and lamellar shaped scars. There is some edge crushing, but this specimen does not appear to have been used as knife.

Marshall Points: N=1 (Figure 4.5g)

Description: These are medium sized points with deep corner notches, long barbs, thin ovate blades and straight to convex blades (White 1968; Morrow 1984:75). The points are usually found in the eastern half of Iowa and are associated with Middle Woodland period contexts.

The specimen from Stratum I Block C is made from heat treated Burlington chert. It is a large point, now missing the distal blade and shattered in several pieces. The base is concave because of a number of softhammer thinning flakes. The point was shaped by lamellar and expanding softhammer percussion crossing the center of the point. The edges are finished with finer softhammer percussion and tertiary retouch. The edges of the point have been resharpened. The point is about 3.2cm wide and .65cm thick.

Mills Points: N=1 (Figure 4.5c)

Description: Mills Points are named for examples in southwest Iowa and are described as small, narrow points with narrow necks, deep corner-notches, slightly barbed shoulders and straight to concave bases (Morrow 1984:78). They are associated with the late Late Woodland period. Similar unamed styles have been found in northeast Iowa (Logan 1976). In Missouri there is a variation of the Reed style point that closely resembles the illustrations of Mill points (Chapman 1980).

Block B contained an example of a Mills point. This specimen is very small, measuring 2.5cm long, 1.5cm wide and .3cm thick. The notches actually are set more on the than side than the corner, and they are relatively broad (.6cm) and deep (.2cm). The basal ears are squared and resemble the basal ears of Keed point styles. The blade is very narrow and has a straight-edged isosceles triangular shape. The base is concave. This specimen is made of Burlington fossiliferous chert on what appears to be a secondary thinning flake. The tool was thinned on the dorsal surface by the removal of several expanding softhammer flakes that meet along the central ridge. The edges were formed continuous pressure flaking. The ventral face still retains portions of the original surface. Although there is evidence of at least one flake removed by softhammer percussion, for the most part the ventral face was shaped by continuous pressure flaking. From a technological standpoint this tool relates to the hafted flake tool industry.

Reed Points: N=4 (Figure 4.5b)

Description: Reed points are small triangular points with moderately deep side notches set close to the base. The basal ears are parallel-sided to contracting and well out of line with the blade configuration. The base is generally straight to convex. This point style is usually associated with Late Woodland cultures (Chapman 1980; Morrow 1984).

There is a single specimen in this category from Block B. It is small, measuring 2.4cm long, 1.6cm wide and .4cm thick. It is made on a secondary thinning flake of Moline chert. The blade is short (1.3cm) and the notches are relatively deep (.3cm) and wide (.5). This specimen was manufactured by pressure flaking along only the margins of the tool. Portions of the ventral and dorsal faces of the original flake blank are still visible. Steep, bifacial pressure flaking along occurs along the entire tool outline, including the notches, distal and proximal ends, and the lateral margins. This technique is a quick and efficient method of manufacture that enhances the tool's longevity by allowing for easy tool retouch and maintenance. Because of similar technological characteristics, this projectile point is associated with the hafted flake tool industry.

There are three examples of Reed style points from Block C. They are somewhat smaller than the above specimen, ranging in size from 2-2.1cm long, 1.2-1.5cm wide and .4-.6cm thick. The notches are .5cm wide and .2cm deep. Two of the Block C specimens are made on white Burlington chert. The third specimen is heat treated Burlington chert.

Table Rock Pointed Stem: N=1 (Figure 4.5e)

Description: Small contracting stem specimen with the stem ending in a pointed base. The blade is triangular with the widest portion at the shoulder. Shoulders are often slight, creating a somewhat elongated diamond-shaped appearance. There are no barbs. This type is associated with the Late Woodland and Mississippian periods in Missouri (Chapman 1980:313).

The single specimen in this class was recovered from Block C and is 4.9cm long, 1.9cm wide and .9cm thick. It was formed by secondary softhammer flaking, leaving small expanding flake scars which meet along a central ridge. Tertiary flaking is discontinuous and limited to retouching. This specimen is heat treated and probably functioned as a knife.

Unidentified Projectile Points: N=2 (Figure 4.5i)

There is one specimen from Block A that cannot be categorized. It is a small, triangular, unifacially shaped, side-notched projectile point. A small portion of the distal tip is broken transversely, and retouch along the right lateral edge has created an asymmetrical shape and removed much of the side-notch. The remaining notch is very shallow (.1cm) and the base is straight. This specimen measures 2.7cm long, 1.4 wide and .5cm thick. It is constructed on a small Burlington chert interior flake removed by hardhammer percussion and closely resembles the hafted flake tools recovered from Stratum I. The flake was shaped by initial edging only. Softhammer percussion, resulting in shallow, short lamellar flake scars that do not reach the center of the blade, was used to shape the flake. Beveled retouching was done by pressure flaking. Edge damage suggests this tool was used as knife in a scraping motion on relatively soft material.

The second specimen in this category came from Block C. It is a small triangular projectile point blade. It is broken at the neck and the stem is missing. This point appears to have been corner or side notched. It is finely made with a very thin biconvex cross-section. Secondary thinning consists of lamellar softhammer flaking. Tertiary flaking was accomplished by continuous pressure flaking. This specimen closely resembles Pelican Lake or possibly Cahokia projectile point blades (Morrow 1984).

Unidentifiable Projectile Point Fragments

Block A contained no members of this class, but in Block B were two fragments of what appear to be projectile points. One specimen consists of a triangular distal fragment that has a diagonal transverse break. This specimen is relatively thick (.7cm) for its width (1.5) and of Burlington chert. Evidence of

the original ventral and dorsal faces is visible. It was thinned by steep lamellar softhammer flaking and retouched by pressure flaking. The steep flaking and evidence of the original flake blank surface suggests this fragment was manufactured in a manner similar to the Reed and Mills points. The second specimen is a very thin (.5cm) medial fragment of Warsaw chert.

There are 4 unidentifiable fragments from Block C. They include two very small distal tips that are finely made and very similar to the unidentified blade fragment noted above. Included in this category are a small medial fragment and a basal corner fragment.

#### Gun Flints: N=3 (Figure 4.3a)

These items from Stratum I consist of small, rectangular shaped tools that range in size from 2.0-2.1cm long and 1.8-1.9cm thick. The thickness is more variable (.5-1.0cm). Edge angles are 40-45 degrees. Two specimens have triangular convex cross-sections, and the third (thinnest) example is plano-convex. All 3 examples have straight steep working edges on both lateral margins and the distal end. Continuous bifacial retouch occurs on all the working edges. Use-wear is continuous and bifacial and consists of heavily crushed and battered edges. One specimen is manufactured from coarse white Burlington chert. Another is a red and cream mottled chert, and the third is a fossiliferous gray mottled chert (possibly fire-smudged). All three have an equilateral tabular shape, flat flaking on the face and steep edge retouch, and two specimens have impact-type crushing typical of gun flints (identification confirmed by T. M. Hamilton of Miami, Missouri, and by Terry Norris, St. Louis Corps of Engineers, 3/25/87). Norris also indicates that gun flints manufactured of native cherts are more typical of the early Historic period and often are associated with triangular flake points, like those from Sand Run (see above).

#### Chipped Stone Tools: Stratum II

A total of 69 chipped stone tools was recovered from Stratum II (Table 4.23). Of this total 29 are diagnostic hafted tools, e.g. projectile points, re-worked scrapers or drills (Tables 4.24 and 4.25). The remaining 40 specimens include one primary uniface, 5 initially edged bifaces, 14 primary bifaces, 10 secondary bifaces and 10 drills. Hide scrapers occur only on reworked projectile points.

#### Unifacial Chipped Stone Tools: N=1

Block B produced one primary uniface fragment. This specimen came from level 8 and appears to be a distal end measuring 3.7cm wide and .9cm thick. It was shaped into a blunt



ovate by steep expanding hardhammer percussion. Use-wear consists of perpendicular step terminated flake scars on the ventral surface. The edge angle is 42 degrees. This specimen was probably used as a scraping tool on a relatively hard material.

Initial Bifaces: N=5

There is one initial biface fragment from Block A. It is manufactured on a piece of warsaw tabular chert. This fragment, broken diagonally as well as obliquely, was shaped by lamellar softhammer flaking. It is relatively thin with an edge angle of 34 degrees.

The second specimen in this class, made of Burlington chert, is from feature 13 Block B. It is triangular in shape with a biplano cross-section and was made from an expanding secondary decortication flake blank. Initial edging was accomplished by short expanding softhammer flaking along all three edges. This tool appears to have functioned as a knife and was not hafted. It is 4.3cm long, 3.3cm wide and 1.0cm thick with an edge angle of 29 degrees.

Three initial bifacial tools were recovered from Block C. One of which is a whole specimen made on a fine grain dark gray and blue speckled white chert. It was found in level 9 and is relatively small, measuring 3cm long, 2.9cm wide and .9cm thick. It has an edge angle of 35 degrees, a triangular shape and a biplano cross-section. Initial edging was carried out by removing a discontinuous series of expanding hardhammer flakes.

The second specimen, found in level 8, was manufactured in a manner similar to the piece of warsaw tabular chert, but it has lamellar softhammer retouching as well. The edge angle is 36 degrees, and the tool is .7cm thick.

The third initial biface, made on coarse grain Burlington chert, was found in level 6. It has a disk shape and biconvex cross-section. The raw material has numerous fracture lines so that flaking was limited to the edges and the striking platform of the original flake blank. Thinning and retouch was accomplished using expanding softhammer flaking. This tool measures 5.1cm long, 5.0cm wide and 1.1cm thick. The edge angle is 32 degrees. It appears to have functioned as knife, with the striking platform used as backing.

Primary Bifaces: N=14 (Figure 4.6c,d)

The single primary biface in Block A is a thick (1.9cm) longitudinal fragment with 44 degree edge angles. This specimen was shaped by expanding hardhammer flaking and may actually be a double-platform core fragment.

There is a total of six primary bifaces from Block B. Three specimens, a corner fragment, a distal portion and a whole primary biface are from level 7. One corner fragment is from level 8. The other two, a corner fragment and a medial fragment, are from features 3 and 16 Block B.

The whole specimen is 5.2cm long, 4.2cm wide and 1.6cm thick. It has a steep edge angle (44 degrees) and an oblique break on the distal end. This tool was shaped by steep broad expanding hardhammer flaking as well as shallow expanding softhammer flaking. There is no indication of a hafting element and very limited use-wear.

A primary biface distal fragment is narrow (3.2cm) but relatively thick (1.8cm) with a bitriangular cross-section and moderately steep edge angle (40 degrees). This specimen was formed by steep expanding hardhammer flaking. The distal tip is very narrow (1.2cm) and may have functioned as a perforator or a drill.

Seven primary bifaces were recovered from Block C: one each in levels 6, 7 and 8, 3 in level 9 and one in level 10. All of these tools are made of Burlington chert, except for one corner fragment consisting of heat treated Warsaw tabular chert. Five specimens are whole, one is a corner fragment and one is a longitudinal fragment.

The 5 whole specimens all appear to have functioned as digging tools (Figure 4.6d). Four of them have evidence suggesting they were hafted. The general size of these primary bifaces are indicated below. All measurements are in centimeters, except for the edge angles which are degrees.

N=5	Mean	Standard Deviation	Max.	Min.
Length	5.0cm	1.0	6.4	3.7
width	3.9	.6	4.5	2.9
Thickness	2.0	.5	2.5	1.5
Edge Angle	47.0 degrees	4.0	52.0	42.0

Three of the digging tools are rectangular, and 2 are pointed ovates. The cross-sections include 3 biconvex and 2 plano-triangular types. The hafting elements are characterized by contracting stems with convex or straight bases. The stems were manufactured by the unifacial bilateral removal of steep expanding hardhammer flakes. In some cases basal thinning, using softhammer percussion, also is evident. The blade portions were shaped by steep expanding hardhammer flaking, and in some cases both lamellar and expanding softhammer thinning is evident. Use-wear evidence includes rounding and polishing.

Secondary Bifaces: N=12 (Figures 4.6a, 4.7a)

Block A contained the medial fragment of one secondary biface from Feature 5. This specimen, measuring 3.7cm wide and 1.2cm thick, is broken transversely in two locations and has an edge angle of 38 degrees. It is made of heat treated Burlington chert and has expanding softhammer flake scars.

There are two specimens in this category from Block B. The first one, made of Warsaw tabular chert, comes from feature 1 Block B level 9. It is broken diagonally, and the distal end is missing. It has a plano-convex cross-section typical of tools made of Warsaw tabular chert. This specimen was thinned by softhammer percussion, resulting in shallow expanding flake scars which meet along a central ridge that consists of cortical remnants on both faces. This specimen appears to have been hafted. The hafting element consists of a wide expanding stem approximately 1.3cm long and 3.0cm wide. It is separated from the tool's blade by ground and abraded contracting edges. The widest portion of the tool is 3.5cm. The base is straight and basal thinning is evident in the form of a series of contiguous lamellar softhammer flake scars. The blade has parallel edges with moderate damage.

The second specimen, consisting of Burlington chert, was recovered from level 9. It has a triangular shape with a plano-convex cross-section and measures 4.4cm long, 3.1cm wide and 1.0cm thick. The base is straight with a flat edge retaining a cortical surface. Basal thinning occurs on the dorsal face and is indicated by 3 expanding softhammer flake scars. The ventral face was thinned by the removal of several expanding softhammer flakes. The dorsal surface was thinned in a similar manner, but most of the flakes hinged toward the center of the tool creating a "humped" appearance. Discontinuous pressure flaking is evident on the distal tip of the dorsal surface. This specimen was hafted in a manner similar to the preceding specimen, but the stem is much shorter (.9cm) with the same width (3.0cm). Both this and the previous tool functioned as knives and have been re-sharpened.

Eight secondary biface fragments were recovered from Block C. There is one distal end, 2 proximal ends, one medial fragment, one longitudinal fragment and 3 unidentifiable fragments. The distal end, found in level 7, appears to have been broken during the manufacture stage. It has plano-convex cross-section and is shaped into a pointed ovate by expanding softhammer flaking supplemented by pressure flaking. An assortment of hinge and step fractures on the dorsal face resulted in a "humped area" where the transverse break occurs. This specimen is 2.8cm wide and .6 thick. The humped area is much thicker than the remaining portion of the tool (1.5cm).

One of the proximal fragments is manufactured on a piece of Warsaw tabular chert and is very close in size to the preceding

tool (2.8cm wide, .6cm thick). This specimen was thinned by lamellar softhammer flaking and has a plano-convex cross-section. The base is straight. The lower lateral edges are contracting, but there are no obvious indications of hafting. Use-wear along the upper portions of the lateral margins suggests this specimen may have functioned as a knife.

The second proximal fragment, made of Burlington chert, is narrower (2.3cm) and thicker (.9) than the preceding specimen and has a biconvex cross-section. Thinning was accomplished by softhammer flaking. The base is a straight edged unaltered flat cortical surface.

The medial fragment is made of heat treated Burlington chert and measures 2.0cm wide and .8cm thick. It was manufactured by softhammer flaking and discontinuous pressure flaking that formed a biconvex cross-section.

The remaining fragments consist of 2 Burlington chert specimens, one Warsaw chert specimen and one blue-grau-tan speckled chert specimen.

Drills: N=10 (Figure 4.8a,b)

Two drills were recovered from Block A. One specimen from Feature 8 Block A is relatively wide (2.1cm) with a thick (1.1cm) bitriangular cross-section. The working edges are crushed and battered. It is made of heat treated Warsaw tabular chert. The second specimen, made of Burlington chert, fits into the simple drill category. It has an oblique break along the left lateral margin, a flat biplane cross-section and was shaped by shallow expanding softhammer flaking with discontinuous pressure flaking.

There were two drills recovered from Block B. One specimen, found in feature 1, is broken transversely and represents the distal portion of a relatively large tool. Although broken, it is relatively long (5.2cm) and thick (1.5cm) with a bitriangular cross-section. It is not very wide (2.3cm). Made on a coarse grain fossiliferous Burlington chert, this tool was thinned by expanding softhammer flaking. Many of the flakes are hinge or step terminated along the central ridge of the artifact, which contributes to the shape of the cross-section and adds to the thickness of the tool. The second specimen is a simple drill made on a blade. This tool is discussed in detail under the heading of "blade tools."

There are 5 drills from Block C. The two whole specimens and one distal fragment are from level 7, the other distal fragment is from level 9, and there are two medial fragments, one from level 6 and one from level 7.

The two whole drills are about the same length (6.0 & 6.5cm) and thickness (1.1cm and .9cm), however one specimen is half

again as wide as the other (2.1cm and 1.4cm). The narrow specimen has a biplano cross-section and both working edges. All of the flake scar ridges on both faces are intensely rounded. The widest portion of the tool is in the center, and both ends taper into elongated points with rounded tips. This specimen is made on a fine grain heat treated tan chert. It was formed by steep expanding softhammer flaking and retouched by pressure flaking.

The wider drill has a plano-triangular cross-section and a long narrow ovate shape. The proximal end is straight and the parallel lateral margins taper into a chisel-like distal end. This tool was manufactured by removing a series of contiguous expanding softhammer flakes resulting in scars which meet along a central ridge (the thickest portion of tool). The lateral margins are heavily abraded with numerous step and hinge terminated flake scars perpendicular to the working edges. The distal end does not appear to have been utilized or retouched. This specimen is made on a Burlington chert.

One of the medial fragments made of Burlington chert is very small with two transverse breaks. However, it is relatively narrow with a bitriangular cross-section and closely resembles a drill. The second medial fragment made of very coarse grain fossiliferous Burlington chert is a somewhat larger specimen. It has a steep biplano cross-section with heavily battered lateral edges.

The distal fragment from level 9 is made of Warsaw tabular chert. This specimen is relatively flat with a plano-convex cross-section. It is broken transversely with the proximal end missing. This specimen was manufactured by removing shallow expanding softhammer flakes, resulting in flake scars which meet along a central ridge. It is shaped into an elongated point producing a bit resembling a chisel. The lateral edges are heavily battered.

The second distal fragment represents the tip of a drill bit. It is made of Burlington chert and has a bitriangular cross-section. It was shaped by steep pressure flaking along the lateral edges.

Projectile Points and Diagnostic Hafted Tools: N=29

Ansell Constricted: N=2 (Figure 4.91)

Description: This projectile point type is described by White (1968:75) as having a subtriangular blade with a convex base. Two lateral indentations placed along the lateral margins of the proximal section of the long narrow blade form an irregular expanding stem. This point is similar to the Steuben type and is associated with the late Middle Woodland period.

There are 2 specimens from Stratum II, both found in level 6 Block C. One point is made of Keokuk chert and is relatively long (4.8cm) and thick (.9cm) for its width (1.8). The edge angle is steep (45 degrees), and the cross-section is bitriangular. The shoulders are wider than the base and slightly rounded. The basal edge is faceted like the Ansell point recovered from Stratum I. The blade was formed by steep shallow expanding softhammer flaking, resulting in flake scars meeting along a central ridge. The edges are heavily battered with perpendicular hinge and step terminated wear scars evident on both faces. This tool functioned as a knife in a scraping motion on hard material. A similar projectile point was recovered from Stratum I, but was not as heavily used.

The second specimen is shorter (3.9cm) but wider (2.0cm) and much thinner (.6cm) than the first specimen. The edge angle is lower (30 degrees) as well. The base is narrower than the shoulders, which are rounded. The basal edge was thinned by softhammer and pressure flaking on the ventral face. Although manufactured in a manner similar to the preceding specimen, the blade still retains portions of the original ventral surface. Use-wear is similar to what is observable on the first specimen, implying that both tools are functionally as well as technically related.

Besant: N=1 (Figure 4.9f)

Description: This type is a medium- to small-sized point with a broad blade and shallow side notches which create a short stem. The shoulders are the widest part of the tool, and the basal ears are convex. This type is similar to Matanzas points but are usually associated with the Middle Woodland period. This style of projectile point is rare in Iowa (Morrow 1984).

The single example in this class, found in level 10, measures 3.2cm long, 2.1cm wide, and .6cm thick with a 28 degree edge angle. The notches are relatively small (.5cm wide, .3cm deep), perpendicular to the central axis of the tool, and were manufactured by removing one small notch flake from each face. This specimen has a diagonal break along the base, and the portion of the lower lateral margin and one basal corner are missing. The remaining basal ear is rounded, and the base appears to have been straight or slightly concave. The blade has a pointed ovate shape with convex lateral margins. It was manufactured by removing expanding softhammer flakes, which extend the width of the blade. Continuous tertiary pressure flaking occurs along the edges.

Cedar Valley: N=2 (Figure 4.9e)

Description: Small points with short narrow expanding stems and barbed shoulders. Blades range from triangular to slightly

convex. Bases are frequently ground. This type may be related to Late Woodland Koster type (Morrow 1964:44).

The two specimens in this class are from block L levels 6 and 9. The first specimen is small (3.2cm long, 2.3cm wide, .5cm thick) with a low edge angle (24 degrees) and a biconvex cross-section. The notches are relatively large, .8cm wide and .4cm deep. The blade is triangular with straight edges and barbed shoulders. The base is slightly convex and heavily ground. This specimen is made of heated Burlington chert. It was shaped by shallow lamellar softhammer flaking and continuous expanding pressure flaking. The second specimen is somewhat larger (4.0cm long, 2.4cm wide, .6cm thick) and is made on Warsaw tabular chert. It is almost identical to the preceding specimen, except the blade edges are slightly convex instead of straight.

Gibson: N=4 (Figure 4.9j)

Description: Medium-sized point with a triangular blade, deep and wide corner notches, and a convex base with pointed basal ears. Gibson points are associated with the late Middle Woodland Period (White 1968:75)

The first specimen in this class is from Block C level 8. It has a diagonal break and is missing the distal end as well as most of the right lateral margin. It is relatively wide (2.8cm) and thin (.6cm) with a low edge angle (31 degrees). The notches are very wide (1.0cm) and deep (.6cm). The base is narrower than the shoulders and is slightly convex. Basal thinning was carried out by removing a series of bifacial lamellar softhammer flakes that extend the length of the stem. The blade was formed by broad expanding softhammer flaking with expanding pressure and lamellar softhammer retouch flaking. The blade is triangular with straight lateral edges.

The second specimen from Block B level 7 has an oblique break along the distal lateral margin and a diagonal break on one basal ear. It is 5.4cm long, 2.8cm wide and .8cm thick. The notches are .7cm wide and .5cm deep. This specimen was shaped by expanding softhammer flaking and appears to have functioned as a knife. Basal thinning was done in the same manner as the preceding specimen.

The third specimen made of Warsaw tabular chert is from Feature 6 Block B. It is large (9.5cm long, 3.8cm wide, 1.1cm thick) with a long incurvate blade. The blade has a bitriangular cross-section and is obviously a drill. It was shaped by steep short expanding softhammer flaking that resulted in flake scars converging along a central ridge. The hafting element has biconvex cross-section. The stem is narrower than the shoulders, but the deep (.4cm) and wide (1.4cm) corner notches give it an expanding shape. The base is convex and was thinned on the

dorsal face by the removal of one large expanding softhammer flake plus a series of tiny pressure flakes. The ventral face was thinned by removing a series of contiguous lamellar softhammer flakes. Basal grinding is extensive. The barbs on both shoulders are broken, but the pointed basal ears remain.

The fourth specimen has been reworked into a hide scraper, one of only two hide scraping tools in the Stratum II assemblage. The base is convex with pointed basal ears. Basal thinning was conducted by lamellar softhammer flaking on both faces. Basal grinding also is evident. The notches now appear as side notches, but this is a result of the transverse retouching and wear along the distal (working) edge of the tool. Originally, the notches probably looked like the traditional Gibson corner notches. The notches are presently very wide (1.4cm) in relation to their depth (.4cm). The distal portion of the tool represents a typical hide scraper with a convex working edge (in order not to damage the hide) and steep transverse retouching. The working edge is undercut and rounded.

Godar/Raddatz Side-Notched: N=2 (Figure 4.3g)

Description: The Godar/Raddatz types are medium-sized side notched projectile points with triangular blades. The notches are generally medium sized with a deep U-shape. Stems are as wide as the shoulders, and the bases are straight. Basal thinning scars often extend beyond the length of the hafting element. These types often are associated with the Late Archaic period (Morrow 1984; Cook 1976).

Both specimens in this class are from Block B. One example, from level 8 is whole except for a lateral break along each basal ear. This specimen is 5.3cm long, 3.1cm wide, and .9cm thick. The notches, orientated perpendicular to the central axis of the tool, are .6cm wide and .5cm deep. The blade is triangular with straight edges and was fashioned by broad shallow expanding softhammer flaking with discontinuous pressure flaking. Basal thinning was conducted by lamellar softhammer flaking that extends almost the length of the hafting element on one face.

The second example is from Test Unit 7 level 7. The basal area is broken transversely, so it is difficult to accurately assign this specimen to the Godar/Raddatz category. However, it appears to have been laterally notched. The blade is almost identical to the first specimen, having a triangular shape and straight lateral edges. The blade was formed by broad shallow expanding softhammer flaking and discontinuous pressure flaking. The U-shaped notches are deep (.6cm) and orientated perpendicular to the central axis of the tool.



Manker Corner-Notched: N=2 (Figure 4.9h)

Description: Broad, medium-sized corner-notched to stemmed points generally associated with the late Middle Woodland period (White 1968; Morrow 1984). The notches are generally orientated at a 45 degree angle from the corner of the blade, which is relatively thick. Bases generally are convex.

The first example made of Warsaw tabular chert is missing the distal tip. Approximately one-third of the blade and is very thin (.9cm) in relation to its maximum width (3.8cm). The notches are almost twice as deep (.8cm) as they are wide (.5cm). The secondary flake scars were created by broad shallow softhammer flaking. Tertiary flaking consists of continuous expanding pressure flaking. The cross-section is biconvex. This specimen does not appear to have functioned as a knife.

The second specimen made of Warsaw tabular chert represents only a corner fragment that is broken both transversely and longitudinally. It includes a portion of the base, stem and lower lateral margin. The fragment is .9cm thick. The notches, orientated at a 45 degree angle to the central axis of the tool, are .8cm wide and .5cm deep. The edge angles vary from 31-34 degrees. Two similar specimens came from Stratum 1.

Manker Stemmed: N=2 (Figure 4.9a)

Description: Medium-sized modified notched point with a straight expanding stem and short barbs. Bases are straight to convex. This type is generally associated with the late Middle Woodland period (White 1968:73).

There are two specimens in this category. The first specimen made of Warsaw tabular chert is from Block B level 8 feature 7. It has an expanding stem and an incurvate blade as a result from extensive re-sharpening. This tool appears to have functioned as a drill. The base is straight and has been ground. The second specimen made of Knife River flint is from Block C level 9. It also has an expanding stem, an incurvate blade, straight base, basal grinding and functioned as drill. Extensive edge rounding occurs on the lateral margins and the distal end.

Snyders Corner Notched, modified stem category: N=1 (Figure 4.9c)

Description: Medium to large ovate point with deep round corner-notches. These notches are described as "occasionally developing into a modified form which produces a straight-sided expanding stem ("Modified stem category"; White 1968:71). This point is associated with the Middle Woodland period.

There is one specimen from Block A that closely resembles the modified stem category or Victory variety described by White (1968:68). This specimen is missing most of the blade, but the remaining part is very wide (4.9cm) and was shaped by broad shallow expanding softhammer flaking. The stem is short (1.0cm). The notches are shallow (.3cm) and wide (.8cm), creating a roughly straight-sided expanding stem.

Unidentifiable Blade Fragments: N=5

The five specimens in this category are divided into two groups: those with wide triangular shapes and those with narrow isocetes triangular shapes. The first group contains 3 specimens that range from 2.5-3.3cm in width. All three are from Block B: two from level 9 and one from level 7. Two members of this group have flat biplane cross-sections, while a third specimen has a thicker biconvex cross-section. All 3 were shaped by shallow expanding softhammer flaking, and 2 have discontinuous pressure flaking. One is made of warsaw tabular chert. The remaining two consist of the an unidentified dark gray-blue-white speckled chert. All three blades are triangular with straight (knife-like) lateral edges and have transverse breaks across the neck of the hafting element. However, the upper portions of the notches remain. At least one specimen appears to be corner notched, and evidence of a barbed shoulder is present. The notch remnants on all three specimens have a concave appearance, which may indicate all were corner notched. One of these artifacts has an oblique break on a upper lateral margin and all three have crushed edges as well as perpendicular and/or oblique step terminated flake scars along the lateral margins. These tools appear to have served as knives for cutting and scraping relatively hard materials. The general manufacturing techniques, the blade morphology, and the provenience of these artifacts suggests that they are related to the Manker/Gibson projectile point styles.

The second group also contains 3 specimens: one from Block B level 8, one from Test Unit 6 level 10 and one from Block C level 7. This group represents blade fragments which are very narrow (1.7cm). The first specimen made of heat treated warsaw tabular chert has a transverse break across the neck of the hafting element. The upper portions of the notches remain and are perpendicular to the central axis of the tool. The shoulders are rounded. This specimen has many similarities to the Ansell constricted point style (White 1968). The second member of the narrow blade group has slightly convex lateral margins, an oblique break at the distal end and a medial transverse break. This specimen is made of heat treated Burlington chert. The third artifact in this group is a distal tip with a diagonal break. This specimen is also made of heat treated warsaw chert.

Unidentified Fragments: N=5

The five specimens in this category consist of a partial stem/basal fragment, a longitudinal fragment, a distal tip, an end fragment of some sort, and a medial fragment. All of these artifacts are from Block B levels 8 and 9, and features 31, 7 and 9. Four specimens are made of Warsaw chert, and one is Burlington chert.

Chipped Stone Tools: Stratum III

There is a total of 114 chipped stone tools from Stratum III, 47 of which are projectile points (Tables 4.24-4.26). The remaining 67 artifacts consist of unifaces, bifaces and drills.

Unifacial Chipped Stone Tools: N=5

There are 3 unifacial tools from Block B, one each from levels 12, 15, and 19. All 3 are broken transversely and represent 2 distal and one medial fragments. The working edges are relatively steep, ranging from 42 to 49 degrees. They range in size from 2.4cm to 3.5cm wide and .8cm to 1.3cm thick.

One specimen is made on a Winterset chert, hardhammer interior flake. The dorsal surface was shaped unifacially into a blunt ovate by the removal of expanding hardhammer flakes, the distal portions of which converge in the center of the tool. Use-wear consists of edge rounding and unifacial perpendicular step and hinge terminated flake scars that indicate this tool functioned in a scraping manner on a relatively hard material.

The second specimen, made on a Burlington chert hardhammer interior flake, was shaped by shallow lamellar and expanding softhammer flaking orientated to the center of the tool. The use-wear is very similar to the preceding specimen, except it is bifacial, not unifacial. This tool apparently functioned as a cutting and scraping relatively hard material.

The third specimen is a medial fragment made of Burlington chert on a hardhammer interior flake. It was shaped by shallow lamellar and softhammer flaking which meets along a central ridge. The use-wear is unifacial and identical to what is present on the preceding two unifaces. It probably functioned in a similar manner.

Block C produced 2 unifaces. The first example from level 10 was manufactured from a hardhammer interior flake blank. This tool measures 4.3cm long, 3.8cm wide and .5cm thick. Although it is relatively thin, this tool has a steep edge angle (50 degrees). It has disk shape with expanding softhammer flaking and continuous pressure flaking along one edge. Bulbar thinning

is also present. This tool appears to have functioned as a knife.

The second specimen is 3 times as thick, measuring 1.6cm. It is 4.7cm long and 3.8cm wide with an edge angle of 65 degrees. This tool has characteristics similar to a backed knife. Expanding softhammer flaking occurs along the right lateral margin of the dorsal face and is supplemented with continuous pressure retouch. Although the use-wear is bifacial, only one flake was detached from the ventral face. This tool probably functioned as a knife.

#### Initially Edged Bifaces: N=4

The two blunt oval specimens in this class are from Block B, one each from levels 14 and 15. Both of these tools are made on Burlington chert flake blanks and range in size from 4.5-7.0cm long, 3.5-4.5cm wide, .9-1.7cm thick.

The largest specimen appears to have been a double-platform core that was bifacially flaked along one of the lateral edges to create a sharp straight cutting edge with a 44 degree angle. The opposite lateral edge is unifacially flaked to form a steep (65 degrees) convex scraping edge. The distal end is polished and rounded from hafting. A hafting element was formed by removing two expanding softhammer flakes, one from each lateral margin, to create a contracting stem 2.1cm long. The widest portion of the tool (4.5cm) is the shoulder. An oblique break along the distal portion of the left lateral edge as well as an assortment of use-wear suggest that this tool functioned as a cutting and scraping instrument and possibly as digging tool.

The smaller specimen has an edge angle of 47 degrees and has been heat treated. It was shaped into a blunt ovate by short bifacial expanding softhammer flaking. Use-wear includes crushed and rounded edges suggesting that this tool functioned as knife.

There is only one initially edged biface from Block C. It is a triangular shaped specimen made from a piece of Warsaw tabular chert. It has flat convex-plano cross-section. Bifacial expanding softhammer flaking occurs along both lateral margins and the proximal end. These flakes tended to hinge or step terminate in the center of the tool, leaving cortex on both faces. Continuous lamellar pressure flaking is present along the lateral margins. Unifacial use-wear suggests that this tool functioned as a knife used in a scraping motion.

#### Primary Bifaces: N=19

A total of 8 primary bifaces was recovered from Block B. One specimen was found in level 13, 2 in level 15, 4 in level 16 and one in level 17. Four specimens are whole, 3 are distal

fragments and one is broken longitudinally. Block C contained 11 primary bifaces, 6 whole specimens and 3 distal fragments. Four examples are from level 15, 3 are from level 12, 2 from level 10 and one specimen is from level 13. Feature 15 Block C also contained a primary biface. All 19 of these tools are made of Burlington chert. Primary bifaces are described according to groups. Each tool is assigned to a specific group on the basis of general morphological and technological characteristics.

#### Biface Group A: N=9 (Figure 4.6c)

Three broken specimens, 2 distals and the longitudinal fragment came from Block B. They are blunt ovate forms which were shaped by expanding hardhammer flaking. Flake scars tend to meet in the center of these tools. Edge angles range from 35-50 degrees. Tool thickness ranges from 1.2-1.6cm. The length of the longitudinal fragment is 5.3cm, and the width of the 2 distal ends are 3.9cm and 3.5cm. Use-wear indicates cutting and scraping functions on a relatively hard materials.

The whole primary biface is a pointed oval with a convex base. This tool is 7.2cm long, 4.7cm wide, and 1.5cm thick with an edge angle of 38 degrees. It was manufactured by expanding and lamellar softhammer flaking. The negative flake scars tend to converge toward the center of the tool. The dorsal face retains a small portion of the cortex in the center of the tool. This example was not hafted and appears to have functioned as a hand-held knife.

The final specimen from Block B is a long pointed ovate. It is broken transversely, and the proximal end is missing. Consequently, it is not known if this tool was hafted. Although broken, this primary biface still measures 8.2cm long and is 4.2cm wide and 1.4cm thick with a 35 degree edge angle. It was manufactured by removing broad expanding softhammer flakes so that they meet along a central ridge. Discontinuous softhammer retouch also is present. The use-wear indicates that this tool was a multi-purpose knife used in cutting and scraping motions on a wide range of materials.

The 4 specimens from Block C are very similar in shape and size. They are blunt ovals which may have been much longer than they were wide. However, all 4 of these tools are broken transversely; only the distal portions remain. They range in width from 3.4-4.9cm and in thickness from 1.4-1.8cm. The edge angles vary from 38-42 degrees. They were manufactured by a combination of expanding soft- and hardhammer flaking with very limited secondary softhammer retouch. As with the Block B tools, these examples appear to have functioned as knives used for cutting and scraping hard materials.

Biface Group B: N=3 (Figure 4.6c)

Three specimens appear to be backed knives. They are medium-sized primary bifaces with one lateral margin that has a flat, plane-like surface functioning as a striking platform as well as backing. When viewed in cross-section these tools resemble an isosceles triangle. The base of the triangle represents the backing while the apex is the working edge. The working edges have use-wear suggesting a knife function in a cutting and scraping motion on a hard material. There is no evidence of hafting. Both surfaces along the working margin were used as striking platforms for removing expanding soft- and hardhammer flakes to create a sharp durable bifacial edge. The opposite margin (e.g. the backing) is a flat plane-like edge. It was narrowed by removing several expanding softhammer flakes using the backing as a striking platform. These tools have edge angles of 48 and 44 degrees. They measure 6.1cm, 5.4cm and 4.7cm long, 3.5cm and 3.3cm wide, and 2.5cm, 1.9cm and 1.6cm thick. The backing measures 3.2x1.4cm, 3.7x2.4 and 3.8x2.1cm. One example was recovered from Feature 15 Block C. The other 2 specimens are from level 16.

This type of tool is distinguished from a primary biface with a longitudinal break by closely examining the flake scars near the backing. If the flat, plane-like surface was a result of breakage one would expect to see only a portion of the flake scar. This is not the case with the backed knives. This tool type probably is closely associated with the double-platform core technique.

Biface Group C: N=7 (Figures 4.6d, 4.7b)

There is one primary biface from Block B that closely resembles the backed knives with regard to manufacturing technique. However, this specimen lacks backing and appears to have been hafted. It was shaped into a short blunt ovate form by steep expanding hard- and softhammer flaking. The flake scars converge toward the center of the tool. This specimen measures 5.0cm long, 4.0cm wide and 2.3cm thick. The shoulder is the widest portion of the tool. The hafting element consists of a parallel-sided stem measuring 1.5cm long and 3.3cm wide. One lateral margin of the stem was shaped by unifacial lamellar softhammer flaking. The other lateral margin was modified by grinding. Unifacial basal thinning is also present. Portions of the blade are polished, indicating this tool functioned as a digging instrument.

Block C contained 6 examples very similar to the preceding tool. Five of the Block C tools are whole; their measurements are given below.

Stratum III

N=(6)	Mean	Standard Deviation	Max.	Min.
Length (5)	4.2cm	1.0	5.2	2.7
Width (6)	3.4	0.5	4.1	2.6
Thickness (6)	1.7	0.2	1.9	1.5
Edge Angle (6)	50.0 degrees	7.1	60.0	44.0

Four of these tools were shaped into a short blunt ovals, while the other two have disk shapes. Three examples have biconvex cross-sections, and the other 3 are plano-triangular. The two discoidal examples have been shaped by expanding softhammer flaking resulting in flake scars that converge in the center of the tool. Each of the discoidal shaped tools has a longitudinal break along one edge. Neither specimen has distinctive evidence of hafting, but it may be that the longitudinal break is actually a transverse break along the neck of the hafting element.

Of the 4 remaining tools, all appear to have been hafted. The hafting elements are characterized by contracting stems with convex or straight bases. These stems are manufactured by removing bilateral flakes, unilateral flakes or by grinding the edges. The tool shoulder is the widest portion. The length of the hafts range from 1.1-2.1cm. These tools were initially shaped in the same manner as the discoidal specimens. However, in some cases lamellar and expanding softhammer retouching of the working edges has eliminated evidence of the primary thinning.

Because of extensive retouching there is no evidence of the polish generally associated with digging tools. General edge damage, such as edge abrasion and steep perpendicular and hinge terminated flake scars is evident. This type of wear, the evidence of hafting, and the overall morphology of the tools is very similar to digging tools from stratum II, which do display distinctive polish and edge rounding.

Secondary Bifaces: N=8 (Figure 4.6b)

Block B contains two secondary bifaces: a distal and a medial fragment from level 15. The medial fragment is relatively wide (3.2cm) and thick (1.2cm). The lateral edges are almost parallel. It was manufactured by broad expanding softhammer flaking, which resulted in a series of flake scars that meet along a central ridge. Secondary softhammer flaking occurs bifacially along both lateral edges, creating short shallow expanding flake scars.

The second specimen is heat treated and somewhat smaller (2.7cm wide, .8cm thick) with 31 degree edge angle. It was manufactured in similar manner. The upper 1.3cm of the distal tip appears to have functioned as drill, since it is .5cm narrower than the rest of the blade. The use-wear consists of

heavily rounded and polished lateral edges. The lower portions of the blade near the transverse break appear to have functioned as a knife.

Block C produced 6 secondary bifaces. The 2 proximal fragments from levels 14 and 15 have flat thin (.9cm and 1.0cm) plano-convex cross-sections and are relatively wide (4.5cm and 3.9cm) with low edge angles (30 and 32 degrees). Both examples were manufactured by removing broad transverse softhammer flakes and short discontinuous expanding secondary flakes. The use-wear suggests both of these tools functioned as knives on a wide range of materials and in a variety of motions.

The 2 secondary biface distal fragments are somewhat narrower (3.1cm and 2.5cm) and thicker (both are 1.1cm) than the preceding tools. These specimens have triangular shapes and biconvex cross-sections. However, they were manufactured in a similar manner by initially removing broad transverse softhammer primary thinning flakes, followed by short expanding softhammer flakes along the margins. The edge angles of these tools are slightly higher than the preceding tool types, and the use-wear is heavier.

The remaining two specimens are whole. One is rectangular in shape and measures 5.1cm long, 2.5cm wide and 1.0cm thick with a 38 degree edge angle. Although this tool was manufactured by initially removing broad transverse softhammer flakes, only remnants of those flake scars are visible because intensive softhammer and pressure retouch. The use-wear is extensive and suggests multiple uses as a knife on hard materials. The second whole specimen is triangular in shape and has a straight base. It has a high edge angle (39 degrees) and a thick (3.2cm) convex-triangular cross-section because the secondary thinning and retouch flakes hinge in the middle of the tool. This was not the case on the opposite face, however, which reveals the broad transverse softhammer flaking described for other examples. Use-wear is extensive and indicates use as a knife on hard materials.

#### Drills: N=16 (Figure 4.8c)

There are a total of 10 drills recovered from Block B. They have been divided into two categories. The first category consists of 7 specimens, 2 of which are represented by 2 separate fragments. One drill each was recovered from levels 11, 12, 14, 17 and 2 from level 13. The remaining specimen is from Feature 23 level 16. All 7 drills are broken. There are 3 medial fragments and 2 distal fragments which represent 5 separate specimens, and two distal and medial fragments that constitute 2 drills (without proximal ends). These fragments are categorized together because they all have bitriangular cross-sections and have been flaked into elongated points that have tapered, almost chisel-like, bits (when present). They have been shaped by



removing steep short expanding pressure flakes and vary in width from .9-1.4cm wide and .8-1.1cm in thickness. Edge angles vary from 36-51 degrees. Use-wear is characterized by edge rounding and abrasion as well as steep perpendicular hinge and step terminated flake scars.

The remaining 3 specimens are all very different from one another. They are described separately.

The first specimen is a winged drill missing a portion of the proximal end. The bit measures 1.2cm wide and .9cm thick with an edge angle of 43 degrees. The winged element of the tool measures 2.4cm wide and is .9cm thick. It has biconvex cross-section.

The second specimen was created from a parallel-sided end flake that was detached from a core by hard hammer percussion. This example is heat treated and measures 3.5cm long, 1.2cm wide and .4cm thick with a biplano cross-section. The bit portion measures 1.3cm long and was shaped by steep pressure flaking. This tool appears to have been hand held.

The final specimen is an unusual type of drill that measures 6.0cm in length, 2.3cm in width and is 1.5cm thick. It was shaped into a narrow pointed ovate shape by expanding bifacial softhammer flaking. Steep unifacial retouching has eliminated the proximal ends of the flake scars on one surface and resulted in a thick convex-bitriangular cross-section. The bit is 2.3cm long and is 2.0cm at its widest portion near the midpoint of the tool, but eventually narrows into sharp point. One edge of the bit is characterized by steep continuous pressure retouch and extensive edge damage from use as a drill. The opposite edge appears to have been re-sharpened by removing one relatively large expanding softhammer flake. There is no evidence of use-wear on this edge. The proximal end is also pointed, but only one of the lateral margins has been flaked. The opposite margin is characterized by a flat plane-like edge. The tip of the proximal end has been worked into a tiny graver. No use-wear was observed.

Block C contained 7 drill fragments: 5 distal and 2 proximal ends. The first specimen, representing the distal and medial portions of the bit, was recovered from level 13. It has a relatively wide bit (2.1cm) and a bi-plano cross-section. This example was initially shaped into an isosceles triangle by broad expanding transverse softhammer flaking. Steep expanding bifacial pressure flaking along the lateral margins created a 48 degree edge angle. This example is broken transversely. Use-wear includes intensive rounding and polish on the distal end and lateral margins.

The second distal fragment is very similar to the first and was recovered from Feature 7 Block C. It is wide (1.9cm) with a thick (.9cm) convex-triangular cross-section and a steep edge

angle (50 degrees). This tool was shaped into a steeply edged isosceles triangular by short expanding softhammer flakes that meet along a central ridge. Discontinuous tertiary retouch is also present. The bifacial use-wear consists of intensive edge crushing.

The third example is missing the proximal end and represents the medial and distal portion of the drill bit. It was found in level 15. Although broken transversely this specimen measures 6.8cm long. It is very narrow (1.1cm) and thin (.9cm) with an edge angle of 36 degrees and a bitriangular cross-section. This superbly crafted tool was shaped and retouched into an elongated point by steep shallow expanding pressure flaking. The use-wear, perpendicular step and hinged terminated flake scars, edge rounding and crushing, is not like the intensive edge rounding and polishing found on the preceding specimen. There is no edge damage on the distal tip, only on the lateral margins. The distal tip is not like the worn chisel-like drill tips found in Block B.

The remaining two distal fragments are very small, representing a very limited portion of the lateral margins and the tool tip. The tips are pointed with one specimen having possible wear damage. The other has no evidence of use. The lateral edges, however, have use-wear very similar to what is present on the long narrow example noted above. One fragment came from level 10 the other from level 12 Block C.

The 2 proximal fragments retain hafting elements which are different from each other. The first specimen from level 14 is heat treated and has a T-shape hafting element that measures 3.2cm wide and 1.0cm long. It is the same thickness as the bit (.7cm). The bit is broken transversely, and only 2.3cm of it remains. The excellent craftsmanship of this tool matches that of the long narrow distal fragment. It was manufactured in a similar manner, is very close in size, and has identical use-wear. The edges of the hafting element are completely rounded.

The final specimen from level 10 is very different from the preceding drill but has characteristics similar to those associated with the wide-bit drill. The hafting element is relatively narrow (2.9cm) and long (2.8cm) with a square shape and biconvex cross-section. The bit is 1.4cm wide and .9cm thick with a bitriangular cross-section and an edge angle of 35 degrees. Because of a transverse break only 1.0cm of the bit remains, but it appears to have been shaped by steep expanding pressure flaking. The haft was manufactured by removing expanding softhammer flakes that converge toward the center of the tool. Basal thinning is indicated by a continuous series of bifacial expanding and lamellar pressure flake scars. Edge rounding and polish is observable on the edges and faces of the hafting element. Not enough of the bit is left to observe any use-wear evidence.

Unidentifiable Biface Fragments: N=9

There are 4 specimens in this class from Block C: one each from levels 11, 12, and 2 examples from 13. Three of these fragments appear to have been broken from larger tools and then discarded. The remaining fragment, however, was reworked into a graver. There are 5 examples from Block B: one each from levels 14 and 15, and 3 fragments from level 16. They represent longitudinal fragments with a wide variety of breakage angles.

Projectile Points: N=46

Etley Stemmed: N=1 (Figure 4.10e)

Description: This type is a medium to large sized narrow point with barbed shoulders and parallel to expanding stems. Blades are usually parallel ovates or recurvate. Barbs, if present, point toward the base of the tool. Flake scars are shallow, expanding and massive. Sometimes they meet to form a central ridge, but they may occasionally extend the width of the blade. Etley Stemmed projectile points are associated with the Late Archaic period (Morrow 1984; Cook 1976; Chapman 1975).

The single specimen resembling this type was recovered from level 14 in Block C. It is broken transversely along the neck of the hafting element leaving a portion of the stem but no base. This example is long, measuring 9.3cm even with basal end missing. It is 3.2cm wide and 1.0cm thick with an edge angle of 30 degrees. The lateral margins are parallel to slightly convex. This tool was manufactured by removing expanding softhammer flakes that overlap along the central axis of the blade. Secondary flaking is limited to one face and consists of short discontinuous expanding softhammer flakes. Tertiary pressure flaking also is discontinuous but occurs on both faces. The shoulders are pointed, but the barbs are perpendicular to the long axis of the blade, not orientated downward as is the case with some specimens. The notches appear to have been aligned in a 45 degree angle with respect to the central axis of the tool. They were manufactured by removing 1-3 deep notch flakes from each face. The use-wear is light and suggests that this tool may have been used in a scraping motion on a relatively hard material.

Godar/Raddatz Side Notched: N=7 (Figure 4.10h)

Description: The Godar/Raddatz types are medium-sized side notched projectile points with triangular blades. The notches are generally medium-sized and deeply U-shaped. Stems are as wide as the shoulders, and the bases are straight. Basal thinning scars often extend beyond the length of the hafting

element. These types are associated with the Late Archaic period (Morrow 1984; Cook 1976).

There are two examples from Block B: one is from level 15, and the other was found in Feature 20 Stratum IIIa level 13. The specimen from level 15 is whole and measures 5.6cm long and 2.6cm wide, with a 1.0cm thick biconvex cross-section and an edge angle of 34 degrees. The second example is broken transversely and missing most of the blade portion of the tool. This tool measures 3.2cm wide and is .8cm thick with a biconvex cross-section and an edge angle 30 degrees. Both specimens appear to have been initially shape by detaching expanding softhammer flakes, which resulted in scars that meet along a central ridge. There is also an limited amount of discontinuous pressure flaking. The notches are U-shaped, set close to the base (.7cm) and measure .7 and .6cm deep and .4 and .3cm wide. The notches were manufactured by removing at least 2 notch flakes from both surfaces. The bases are straight and were thinned on at least one surface by lamellar and expanding softhammer flaking that extends the length of the hafting elements (1.2-1.4cm long). The opposite faces were thinned by shorter expanding softhammer flakes. Grinding does not occur, however the basal ears and edges are rounded. The use-wear on the blade portion of the whole specimen indicates use as a knife.

Two of the five specimens from Block C are similar to those from Block B, with U-shaped notches, similar measurements, convex basal ears, notches set close to the base (.7cm), etc. There is one difference, however. The bases are slightly convex and were thinned by removing a single expanding softhammer flake from each face. The negative bulb of percussion gives the base a slightly convex shape. Basal thinning technology similar to this has been observed at a Late Archaic site in Van Buren County, less than 50 miles inland from 13LA38 (Stanley 1987). Both tools are broken transversely and the distal and medial portions of the blades are gone. The hafting elements measure 1.2-1.4cm in length.

The final 3 examples from Block C were recovered from levels 14 (2) and 17 (1). They are somewhat different than those in Block B, because the notches are set higher on the blade (.9-1.1cm from the base), and the basal ears are squared not convex. These points were manufactured differently as well. All three specimens were thinned by removing broad transverse expanding softhammer flakes from both faces. Secondary lamellar softhammer flaking is present the one whole specimen. The other 2 specimens are missing their distal tips and have discontinuous pressure retouch on the lateral margins. The hafting elements vary from 1.6-1.9cm in length. The notches are .3cm deep and .7cm and .6cm wide. The notches are U-shaped and were created by removing 1-3 deep flakes from both faces. The bases are straight and thinned by expanding and lamellar softhammer flaking. The basal thinning scars extend at least the length of the hafting element. All Raddatz/Godar points functioned as knives.

N=(7)	Mean	Standard Deviation	Max.	Min.
Length (2)	---	---	6.1	5.1
Width (7)	2.7	.4	3.2	2.4
Thickness (7)	.9	.1	1.0	.8
Edge Angle (6)	31	2.4	34	28
Notch Depth (7)	.3	.1	.4	.2
Notch Width (7)	.7	.1	.8	.6

Helton: N=1 (Figure 4.10g)

Description: This is a wide-bladed medium- to large-sized projectile point with perpendicular barbs, an expanding stem and a convex base. The blades have no central ridge line formed by flake scars. This projectile point style is associated with the Late Archaic period (Cook 1976).

There is a single specimen in this class from level 12 Block C. This example measures 6.5cm long, 4.1cm wide, and .9cm thick with an edge angle of 30 degrees. The blade is triangular with straight lateral margins and was shaped by softhammer percussion. The result of flaking is broad and shallow expanding flake scars that extend across the width of the tool. Secondary thinning is limited to short isolated expanding softhammer flaking along the lateral margins. Tertiary pressure retouch is evident on both edges, one of which is beveled.

The barbed shoulders are the widest portion of the tool. The notches are deep (.7cm) and wide (1.2cm) with a 48 degree orientation in relation to the long axis of the projectile point. Notches were manufactured by removing one large expanding softhammer flake from each face, then if necessary, one or more steep pressure flakes were unifacially detached within the notch concavity along the lateral margins of the stem. The hafting element measures 1.6cm. The base is slightly convex and was thinned by discontinuous expanding softhammer flaking. Use-wear is evident on both lateral margins and is of the type that suggests use as a knife.

Koster:

Description: Koster points are small corner notched specimens that closely resemble the Pelican Lake type but are smaller. The notches are moderate in size, projecting inward at approximately 45 degrees. The shoulders, the widest portion of the tool, are usually barbed. Stems expand to approximately two-thirds of the width of the shoulders. Bases are straight or convex with occasional grinding. Blade margins tend to be straight or slightly convex. Koster points are associated with the Late Woodland period (Morrow 1984).

There are 2 examples of this projectile point type from Block C. They measure 3.6cm and 3.7cm long, 1.9cm and 1.8cm

wide, and .5cm and .7cm thick, with 28 and 32 degree edge angles. Both specimens are broken and from level 10. One tool is missing the basal edge, although a stem remnant is present. The other example has a longitudinal break and is missing the shoulder and a portion of a lower lateral margin. They were shaped by fine lamellar and expanding pressure flaking creating scars that meet along a central ridge. The central face of one example retains evidence of the original flake blank that allows for a plano-convex cross-section. The second specimen is biconvex.

The notches were manufactured by removing one or two deep flake notches orientated in a 45 degree angle relative to the central axis of the tool. Basal thinning was accomplished by removing a series of contiguous pressure flakes which extend to the bottom of the notches. Edge rounding and a dull polish is evident along the base of one specimen. The basal ears on both specimens are straight but slope inward. The shoulder is the widest dimension of these tools. On one example the shoulders are barbed, while the other has convex shoulders. Both of these tools may have been used as knives.

Matanzas: N=8

Description: There are 5 varieties of Matanzas projectile points (Cook 1976:143): modal, deep side notched, faint side notched, flared stem and straight stem. As the category names indicate, their differences are associated with the hafting elements. Matanzas types are small to medium-sized projectile points with ovate to triangular blades and straight to slightly convex bases. The blades were manufactured by removing expanding softhammer flakes which leave scars that meet along an often poorly defined central ridge. Tertiary retouch is discontinuous and occurs in locations that need retouching or are not in line with the general configuration of the lateral margins. The principal defining characteristic is the placement of notches very close to the basal margin. The basal ears are convex, since the notches end as the basal curve begins. Matanzas points are affiliated with the Late Archaic period (Cook 1976).

Deep Side Notched Matanzas: N=4 (Figure 4.10d)

There are four examples in this category: one specimen from Block B level 15, and 3 specimens from Block C (one each from levels 14 and 15 and one which is catalogued as a surface find). All four specimens are very similar to the Godar/Raddatz group but are somewhat smaller with shallower notches placed closer to the basal margin (within .5cm or less). Unlike the Godar/Raddatz styles the basal thinning scars usually do not extend the length of the hafting element but are terminated at the midway point of the notches.

Two of the examples are broken transversely immediately above the notches. They have straight bases which were thinned by removing tiny contiguous lamellar pressure flakes from both faces. There is one whole specimen with a slightly concave base. The lateral margins are slightly convex giving an ovate shape to the blade. This example is small, measuring 4.0cm long, 1.8cm wide and .7cm thick with 30 degree edge angle. The basal ears and margin are heavily rounded. The final specimen in this category is somewhat larger, measuring 2.4cm wide and 1.0cm thick with a 33 degree edge angle. Although broken transversely and missing the distal end, this example is 4.0cm long. It is also broken obliquely, missing one the basal ears and a portion of the edge. The lateral margins are parallel and heavily battered suggesting use as a knife.

Flared Stem Matanzas: N=2 (Figure 4.10b)

This type is distinguished from the other specimens by relatively wide corner or side notches that give the stem an expanding shape. There are two examples in this class, one is whole and the other represents only a basal corner fragment. Both have been heat treated. The whole specimen has been re-sharpened extensively and has beveled edges with a triangular blade. It measures 3.7cm long, 2.5cm wide, and .8cm thick with a high edge angle (50 degrees) because of the beveled edges. The shoulder represents the widest portion of the tool with the base slightly narrower. Basal thinning consists of the bifacial removal of short contiguous expanding pressure flakes. The basal ears of both specimens are rounded points.

Faint Side Notched Matanzas: N=2 (Figure 4.10c)

There are two specimens that may represent this category. Both are from Block C. One example was recovered from level 12 and the other from level 13. Neither have distinctive side notches, faint or otherwise, but they closely resemble some of the faint side notched Matanzas projectile points illustrated by Cook (1976). However, Cook does note that this particular point style often has only the barest trace of hafting modifications (1976:145) and may often be classified as a knife or preform.

Both of these tools are whole and relatively small, measuring 3.6 and 4.4cm long, 1.8 and 2.1cm wide, and .8 and 1.0cm thick. The edge angles are 32 degrees. The smaller tool was manufactured by lamellar softhammer flaking and the larger tool by expanding softhammer flaking. In both cases the flake scars meet at the center of the projectile points. The hafting elements were made in the same fashion as the blades and in both cases represent squared parallel-sided stems with straight bases. No basal thinning was attempted. The blades are triangular and have been heavily retouched. Use-wear suggests that both examples were used as knives.

Osceola: N=9 (Figure 4.10f)

Description: Osceola points are long, narrow side-notched specimens that range from medium to large in size. Blades range from triangular to ovate. Notches are rounded or squared and moderate to large in size. They are usually set some distance away from the base. Shoulders are pointed or slightly convex. The base tends to be the same width as the shoulders and the basal ears may be squared or convex. This projectile point type is associated with the Late Archaic period (Morrow 1984; Ritzenthaler 1967). There is a total of 9 projectile points: 6 from Block B and 3 from Block C. Two of the Block C examples were recovered from level 15, and the third specimen was found in level 14. Two each came from levels 16 and 17, and one each came from level 15 Stratum IIIb and level 19 Stratum IIIc in Block B. The dimensions of these tools follow:

N=(9)	Mean	Standard Deviation	Max.	Min.
Length (4)	6.3	.6	7.2	5.9
Width (9)	2.8	.2	3.2	2.6
Thickness (9)	.9	.2	1.4	.8
Edge Angle (9)	32	2.5	37	30
Notch Depth (9)	.5	.1	.6	.3
Notch Width (9)	.9	.2	1.3	.8

These projectile points were manufactured by removing shallow expanding softhammer flakes creating scars that meet along a central ridge. Steep discontinuous and continuous pressure flaking occurs along the lateral edges. Four specimens have bevelled edges. The notches are deep, wide, and in all but one instance, rounded. They were manufactured by bifacially removing 2 or more deep alternating flakes. The basal concavities are set in as far as .5cm from the bottom of the basal ears and are 1.8-2.0cm long. These concavities and basal thinning in general were accomplished by removing either a series of tiny contiguous pressure flakes from both faces or several lamellar softhammer flakes extending the entire length of the hafting element.

The hafting element ranges from 1.5-2.0cm in length. The basal ears are either straight and slanting slightly inward or are convex. The basal edges are usually rounded and polished from the hafting apparatus. Wear patterns on the blades suggest these tools functioned as knives as well as projectiles.

Steuben: N=1 (Figure 4.9b)

Description: This type is a medium-sized projectile point with a broad expanding base and a triangular blade. The stems are often as wide or slightly narrower than the shoulders, which are generally straight and form obtuse angles with the lateral



margins of the stem. This point style is associated with the late Middle Woodland period (White 1968; Morrow 1984).

The single specimen in this class was recovered from level 10 Block C. The ventral face was thinned by removing short expanding softhammer flakes, which do not extend far enough across the blade to overlap or even reach each other. A portion of the original flake blank surface remains in the center of the blade. The dorsal surface was thinned in a similar manner only the flake scars tend to overlap or meet along a central ridge.

This specimen is 5.3cm long, 2.7cm wide, and .7cm thick with an edge angle of 33 degrees. The shoulders were manufactured by removing a deep notching flake from each face and perpendicular to the central axis of the tool. The stem was shaped by removing a series of bifacial pressure flakes along the lateral and basal margins. The use-wear indicates that the distal tip of this tool functioned as a drill and the lower lateral margins were used as knives in a scraping and cutting motion on a moderately hard material.

Unidentifiable Fragments: N=18

There is a total of 18 unidentified secondary bifaces in this class: 9 from Block C and 9 from Block B. Block B produced 7 distal ends: 2 from level 17 and one each from levels 12, 15, and 16. Feature 18 Block B contained two distal fragments. There were also 2 medial fragments from Block B: one from level 12 and the other from Feature 23. Block C produced one basal and one longitudinal fragment from level 13. Level 12 had 2 distal fragments, and levels 11, 14, and 15 contained one each. Two side-notched basal fragments were found in Features 11 and 15 Block C. All of these fragments are lumped with projectile points because they have edge angles below 34 degrees and generally have secondary and tertiary retouch.

### Discussion

This analysis focused on the entire chert artifact assemblage recovered from 13LA38, not just selected categories (e.g. projectile points, hide scrapers, etc.). The intent was to generate a data base which can be viewed in relation to three basic archaeological issues and to allow a comparative analysis between strata.

The first of these issues refers to the functional aspects of the assemblage, i.e. what specific information can be gleaned from an artifact that will reflect its actual use. This in turn will aid in interpreting activities that occurred at a site, and subsequently help place the site within a generalized hunting and gathering mode of production. Archaeologically, this issue

revolves around attributes related to use, such as morphology (size, edge angle, shape, etc.) and use-wear (edge damage, polish, etc.).

As noted earlier, there is little functional variability between the assemblages from Strata I, II, and III. This implies there was little change through time in the actual tasks carried out at 13LA38, even though there are obvious technological variations between components. Environmental constraints also remained constant; availability of raw materials like chert and other types of stone, animal and plant resources, etc. probably remained about the same.

There is a total of 50 primary bifacial and unifacial tools with steep edge angles and thick edges that lack an exceptionally sharp edge but are very durable and easily re-sharpened. Thirteen of these primary chipped stone tools were from Stratum I, 16 from Stratum II, and 21 from Stratum III. These tool types are well suited for such tasks as butchering, woodworking, cutting thick stalks, breaking up firewood, digging, etc. Use-wear patterns support these types of activities and indicate both cutting and scraping motions were used. Some of the primary chipped stone tools were hafted. Others gave no indication of hafting.

There is a total of 39 secondary bifaces and unifaces, 15 of which are from Stratum I, 11 from Stratum II, and 12 from Stratum III. These tools tend to have lower edge angles and thinner edges, creating a sharper but less durable edge than what is available with a primary chipped stone tool. Secondary tools appear to have been used in a similar manner to primary tools but may have been limited to specific aspects of the task at hand. Perhaps, secondary chipped was necessary when a sharp edge was needed.

Forty-six drills (21 fragments) were recovered from 13LA38. These drills with various widths appear to have all been used to bore relatively hard materials (e.g. bone, wood, antler, stone, etc.). Sixteen specimens were found in Stratum I, 10 in Stratum II and 20 in Stratum III.

No distinct hide scrapers were found in any of the strata, except one reworked projectile point from Stratum II. The lack of hide working tools may indicate that 13LA38 was occupied during a season that was not conducive for procuring premium hides, such as spring through early fall. Alternatively, other materials may have been utilized for processing hides.

The flake tools recovered from 13LA38 appear to have served functions as knives, graters, perforators and spokeshaves. There are stratigraphic differences, however. In Strata I and II (Table 4.12) 90% of the unhafted flake tools were used as knives in cutting or scraping motions on a variety of hard and soft materials. In Stratum III the percentage of unhafted flake tools

used as knives dropped to less than 70% (table 4.14). This difference is attributed to the greater use of unhafted flake tools as gravers during the Late Archaic. The Late Woodland cultures manufactured gravers and spokeshaves on many of their unifacial and bifacial tools. None of the flake tools from Stratum I was used as a graver. During the Middle Woodland period gravers and spokeshaves appear on both unhafted flake tools (2%) and blades (5%).

The graver spur itself appears to have been used in a similar manner in all three strata (e.g. as an incising tool), as does the spokeshave (e.g. used in a scraping motion on cylindrical objects). Consequently, for gravers the shift from flake tools in Stratum III to chipped stone tools in Stratum I is interpreted as a technological change, not functional. Other flake tool types reflect similar changes in technology, but not function, through time.

Which brings us to the second archeological issue being addressed in this summary: lithic technology. This issue is seen archaeologically in discreet attributes associated with stone tool manufacture. These attributes include detachment techniques, platform types, raw material selection, heat treatment, negative flake scars, flake configuration, plus tool size and shape. Lithic technology goes beyond the investigation of finished tools to include debitage and cores, the by-products of stone tool manufacture. This information is discussed in greater detail in the text, so it will only be summarized here.

Our research indicates distinct technological differences between the debitage associated with the Late Woodland component in Stratum I and the Late Archaic and Middle Woodland components of Strata III and II (Table 4.6). The Late Woodland lithic technology is dominated by softhammer percussion, striking platform preparation, and the use of small cores to produce flake blanks. Softhammer percussion and platform preparation allow the knapper greater control of the application of force, which in turn makes it easier to utilize small nodules and cores.

Heat treatment increases from the Late Archaic to Late Woodland period as well. It is not as evident in the general debitage (Table 4.6) as it is with the flake tools, including blades and hafted and unhafted flake types (Table 4.15). Heat treated debitage represents 8% of the total debitage assemblage from Stratum III. In Strata I and II, heat treated debitage retained a share of 11% within each assemblage.

The occurrence of heat treatment is difficult to approach, especially for an analyst who is not a flintknapper. It is assumed that thermal pretreatment enhances the quality of the raw material used to manufacture an incipient tool. When one looks at the frequency of heat treatment within the total site assemblage of 5,777 specimens, 10% (572 examples) of heat treatment does not seem a large amount. Why were 5,105 pieces

not heat treated? It is likely only prepared cores and chipped stone preforms and/or flake blanks were thermally altered. The vast majority of the debitage, therefore, may be related to core and preform or blank preparation which occurred prior to heat treatment.

A close look at the flake tools demonstrates a surge in the frequency of heat treatment. Of the 18 hafted flake tools recovered from Stratum I, 5 examples (28%) were heat treated. The blades from Stratum II (plus those intruding into stratum III) total 128, of which 85 (66%) were thermally altered. Unfortunately, the heat treatment of cores in general was not recorded. Several Stratum II cores were heated, and certainly both blade cores were heated.

The unhafted flake tools also demonstrate a rise in heat treatment. Of the 474 flake tools, 79 examples (17%) have evidence of this trait. Stratum I contains the highest percentage with 36 occurrences from a total of 140 (26%). The heat treatment of unhafted flake tools drops to 13% (19 of 145 artifacts) in Stratum II. This may be related to an increase in the amount of labor associated with blade production. In Stratum III there is a total of 36 examples of heat treatment (18%) out of the 189 unhafted flakes.

Chipped stone tools also have a high frequency of heat treatment when viewed in relationship with the debitage. A total of 99 projectile points were recovered from all three strata. Of this total, 36 (36%) had evidence of heat treatment. The comparison between components is similar to the total figure. Stratum III projectile points totalled 49 of which 18, or 38% were heat treated. Stratum II has an identical percentage with 11 of 29. In Stratum I the percentage drops to 27%, or 6 of 22 examples.

It is worth noting that the technology associated with chipped stone tool production, especially projectile points, changed considerably with the introduction of the bow and arrow and flake tool technology during the Late Woodland period. The projectile points from Strata II and III were not manufactured from small, soft-hammer flake blanks like those in Stratum I. Small, soft-hammer flake blanks could be mis-identified as secondary or primary thinning flakes were it not for high striking platform angles. Many of the chipped stone tools from Stratum II, especially the projectile points, were manufactured from flat tabular cores. The cores were naturally flat types such as Warsaw tabular chert or prepared double-platform or single-platform tabular cores. In Stratum III projectile points, as well as other chipped stone tools, were manufactured from relatively large flake blanks detached from large cores or from steep, angular double-platform cores.

One might expect that the production of chipped stone tools from flat tabular cores or nodules is somewhat less labor

intensive than using steep angular cores or large hardhammer flake blanks. This would certainly be the case with the small flake tool industry present in the Late Woodland component.

For the most part it appears that the fundamental shift in lithic technology from the Late Archaic to Late Woodland stone tool industries involved an emphasis on greater control of the application of force. This in turn may have reduced the level of labor output associated with stone tool manufacture. The trend is evident in the production of unhafted flake tools (Table 4.15). The difference between the use of hardhammer and softhammer percussion is not as dramatic in flake tools as it is in the general debitage. This shift in detachment techniques may be associated with the blade technology introduced during the Middle Woodland period and continued with the use of hafted flake tools during the Late Woodland period. Both flake tools and blades are detached almost exclusively by softhammer percussion (Tables 4.20 and 4.21) and in most cases have undergone some sort of platform preparation.

The introduction of the blade industry and subsequent hafting of flake tools did not result in the demise of the unhafted flake tool but may have contributed toward a general reduction in size of flakes. The unhafted flake tools of the Late Archaic have a mean length, width and thickness of 3.3cm, 2.9cm and .7cm respectively. During the Middle and Late Woodland periods the unhafted flake tools have a mean length, width and thickness of 3.0cm, 2.6cm and .7cm (MW)/.6cm (LW).

It is interesting to note that the general thickness of unhafted flakes remained the same throughout all three strata. However, the blades and unhafted flakes are much thinner: .4cm and .3cm respectively. It is assumed that the thickness of a flake tool plays a far greater role in its durability than the general length or width. Certainly thicker tools are much easier to retouch.

Blades tend to be longer (3.4cm) and narrower (1.6cm) than flake tools in general, which is probably directly related to their method of production. Hafted flake tools are much shorter (2.5cm) but not much narrower (1.4cm). Their length may be misleading, however, since the working edge in many cases is the distal end.

There appears to be a direct link between hafted flake tools and blades in regard to technology. Blanks were removed by softhammer percussion from prepared cores (e.g. striking platform preparation), and both flake types have similar hafting elements created by a variety of techniques: notching, lateral and basal grinding, bulbar thinning and edge flaking. Heat treatment occurs at much higher frequency than it does with the debitage assemblage.

The cores included in the 13LA38 collection also offer some insight concerning lithic technology. A total of 117 cores was recovered from the three strata. Forty-eight specimens (41%) are from Stratum III, 38 (32%) from Stratum II, and 31 (27%) from Stratum I. This total includes core fragments and exhausted cores. Exhausted cores are present only in Stratum III and should not to be confused with the smaller cores found in Stratum I. The reduction in the quantity of cores through time may be attributed to an increase in the production of tools directly from small, tabular nodules, as opposed to flake blanks detached from large cores. This technique is most apparent with the use of Warsaw Tabular chert and in other chert types are used as well. The use of small cores and tabular nodules has also been documented in the central Des Moines River valley (Stanley and Benn 1985).

One of the interesting aspects of this artifact class is the category designated as core fragments. This category consists of fragments detached from cores to rejuvenate shattered platforms or represents mistakes associated with the failure to adequately control the application of force. We think that the latter situation better explains the presence of core fragments. Their numbers and distribution tend to support this contention. There is a total of 54 core fragments in the collection; 23 (43%) are from Stratum III, and 24 (44%) are from Stratum II. Only seven specimens (13%) are from Stratum I, and these examples tend to be much smaller than the core fragments from Strata II and III.

Hardhammer percussion is the dominant detachment technique (Table 4.6) utilized in Strata II and III. As noted previously, this is not the case in Stratum I. Softhammer percussion is the dominant detachment technique in the Late Woodland component.

Discoidal cores are not present in Stratum III. They do appear in Stratum II in association with the blade industry and continue in Stratum I. Double-platform cores occur throughout all three strata (Table 4.8), but the quantity varies. Eleven specimens occur in Stratum III, and they represent 55% of the whole cores (not including core fragments and exhausted cores) recovered from the Late Archaic component. Only three double-platform cores were found in Stratum II, but the number increases to seven in Stratum I.

Double-platform cores serve a dual purpose. They are used for flake blank production, and can be easily be transformed into primary bifaces and other chipped stone tool types, including drills. They also allow for detaching the maximum number of large flakes. Whereas pyramidal and discoidal cores produce smaller and smaller flake blanks, double-platform cores make it possible to remove flakes which transverse the entire core face(s). The limited number of double-platform cores in Stratum II may be associated with the extensive use of Warsaw tabular chert for biface production during the Middle Woodland period.

Pyramidal cores were probably used only for flake blank production and occur throughout all three strata. They are most numerous in Stratum I, which makes sense when viewed in relation to the flake tool industry associated with the Late Woodland period. Single-platform tabular cores occur only in Strata I and II. This core type may be associated with the use of Warsaw Tabular chert and other types smaller raw nodules, as well as the desire to produce a flat, low-angled tool.

Tested cobbles also occur in only Strata I and II. The presence of this artifact type may indicate a shift from procuring and trimming nodules obtained from bedrock quarries during the Archaic to procuring raw nodules elsewhere. The tested cobbles, as well as other cores and decortication flakes from the Woodland strata, suggest that many of the raw nodules were water-worn and were being procured from outwash terraces or stream channels, as opposed to bedrock outcroppings.

The size of the cores also changes through time. Large cores tend to be associated with the Late Archaic, but cores get progressively smaller into the Late Woodland period. Since Late Woodland chipped stone tools tend to be manufactured on smaller flake blanks, one would expect the final product to be smaller than those types of tools produced during the Late Archaic and Middle Woodland periods. It is not surprising that with introduction of the bow and arrow one sees a reduction in the size of projectile points. However, the reduction in tool size is evident throughout the entire Late Woodland assemblage, especially the flake tools.

The primary and secondary bifacial knives from Strata I and II are for the most part formed by flat, shallow, expanding and lamellar softhammer percussion. Those which were recovered from Stratum III were also shaped using expanding and lamellar softhammer flaking but at a much steeper angle and usually with hardhammer percussion. This may have occurred because of the introduction of Warsaw Tabular chert and a decrease in the use of double-platform cores during the Middle Woodland period.

The digging tools from all three strata (except for two unusual specimens from Stratum I) were manufactured by removing steep but usually shallow hardhammer and softhammer expanding and lamellar flakes. The steep flaking created a relatively thick (mean of 2.0cm) and very durable tool that could endure a large amount of resharpening. One would suspect that stone digging tools tend to become dull very quickly and would need constant retouching. (Most archeologists spend time resharpening the edges of their digging tools. Some even spend more time resharpening than they do digging.) Almost all of the digging tools recovered from 13LA38 appear to have been hafted into the ends of digging sticks, not perpendicular to the stick as with hoes. The two relatively long rectangular primary bifaces (Figure 4.4a) from Stratum I may actually be hoes. They are much

wider and longer and lack the blunt ovate shape of the other digging tools.

There are three different types of drills included in the collection, plus a catch-all category referred to as drill fragments. The latter contains 21 specimens, 13 of which were found in Stratum III. The wide-bit drills totalled 13, six of which were recovered from Stratum II, four from Stratum III, and three specimens were found in Stratum I. Simple drills have been associated with Middle Woodland deposits in Illinois (White 1968) but only two specimens were recovered from Stratum II at 13LA38. The remaining five examples were associated with the early Late and Late Woodland deposits in Stratum I. Simple drills seem to be an outgrowth of the Middle Woodland blade industry and fit easily into the flake tool technology of the Late Woodland period. There were no simple drills associated with the Late Archaic. Only five drills could be identified as winged drills, none of which were associated with the Middle Woodland deposits. Two specimens were found in Stratum I, and the remaining three examples were in Stratum III.

The excavations at site 13LA38 produced a total of 99 projectile points. Twenty-seven specimens represent unidentifiable fragments and seven examples are unknown types. The remaining 55 projectile points were identified by type using the available literature for guidelines (cf. Stanley and Bann 1985; Morrow 1984; Chapman 1979, 1980; Cook 1976; White 1968).

The three Woodland aged points--2 Koster and one Steuben--are intrusive in the Late Archaic components. They came from level 10 Block C, the level which contained the bottoms of Woodland pits. Ceramics also began disappearing at level 10 (see Chapter II).

It is unfortunate that 5 of the 8 Archaic point types came only from Block C. This block contained a mixed midden without discrete cultural components. Block B had clearer stratigraphy, yet fewer points were recovered. Three point types came from the following Block B levels:

Table 4.27  
Block B Projectile Points

	Strata		
	IIIa	IIIb	IIIc
Osceola	-	2	3
Matanzas Deep Notch	-	1	-
Godar/Raddatz	1	-	-

These stratigraphic relationships do not indicate culture change because the sample size is inadequate. It is clear that large,



side notched points dominate the assemblage, and that the smaller Matanzas point type is associated in the same layer with the larger Osceola type. Small and large point types were found from top to bottom in the Stratum III Block C midden. Thus, the Late Archaic point assemblage appears to have been diverse with small and large tool forms. Different functions are not necessarily associated with point sizes, since both sizes functioned as knives among other uses. Larger samples of points from stratified contexts are required to work out functional patterns.

The third archeological issue to be addressed about the lithic assemblage from 13LA38 is cultural influences on the content of the assemblage. Often, archeologists explain certain functional and technological characteristics associated with stone tools by relating them directly to the local environment. These explanations focus on natural resources and assume the tool types used to procure resources were directly related to the resource, without reference to cultural variables: e.g. cultural tradition influencing behavior, territorial and/or kinship relationships, changes in the socio-economic structure, etc.

The archeological record at 13LA38 indicates a trend toward smaller, lightweight tool kits that may actually reflect increased mobility during the Late Woodland period. The amount of fire-cracked rock and groundstone tools--items that are much less portable--associated with the Late Archaic component would seem to support this contention. This trend toward smaller and more lightweight tool kits has been documented in the heart of Burlington chert country and consequently would seem have little to do with the availability, or lack of, chert resources. Late Woodland assemblages from Saylorville Lake in the central Des Moines River valley also reveal use of smaller and more lightweight tool kits during the Late Woodland period (Stanley and Benn 1985).

The Middle Woodland blade industry and the Late Woodland hafted tools have enough related traits (e.g. similar hafting elements, blanks almost exclusively detachment by softhammer percussion, extensive platform preparation, high frequency of heat treatment) to suggest a technological (or cultural) continuum. However, hafted flake tools are not as common as blades when considered as a proportion of their respective assemblages. Nor does the production of hafted tools require as much labor as blade production.

We might wonder, then, whether the blade industry and its technical function or variables have anything to do with environmental adaptation. Although the actual function of blades appears to be largely the same as other flake tools, there appears to be a significantly higher input of labor in their production, plus evidence of extensive curation of cores. Only the finest cherts were used in blade cores, many of which are exotic cherts that were unavailable locally. It would appear that much more labor went into producing blades than could be

recovered from actual use in cutting and scraping tasks. In other words, the energy expenditure in blade production was not optimal or efficient.

Blade production is largely limited to the Middle Woodland and Paleo-Indian periods. These were periods when highly stylized and sophisticated tool types were manufactured. It is reasonable to speculate that stylized bifaces and blade technology embodied a socio-political component not directly related to technical production and function. Otherwise, why was blade production discontinued in the Archaic and Late Woodland periods? Tool types such as blades need to be evaluated within a cultural context, not merely in functional, technical or environmental contexts. For instance, we might inquire whether blades were used by everybody during the periods of manufacture? Or, was the production and use of blades restricted to certain individuals? Did women use blades? What specific tasks, if any, were blades used for, and were blades (socially) required for some tasks (e.g. the burial program)?

What has been attempted in this lithic analysis and discussion is to move beyond the simple cause-and-effect relationship of raw material-technology-function. In a few attributes such as percussion techniques and core sizes and in tool types such as blades, chipped stone and hafted flake tools we have attempted to show that other factors influenced broad trends in the changes in lithic technologies from Late Archaic through Late Woodland periods. Those other factors were social and political, both of which are better seen in an analysis of economic systems (see Chapter VIII).

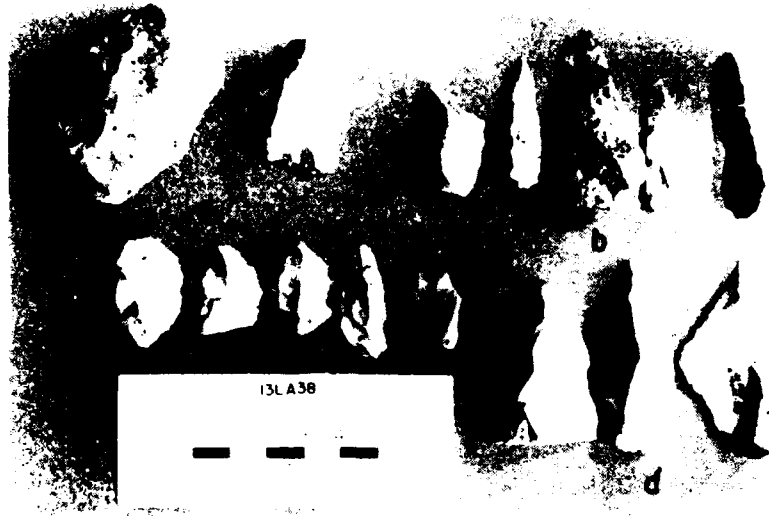

Figure 4.1: Stratum I chipped stone tools; a) two levallois or prepared flakes; b) drills (bits at top); c) hafted flake tools (striking platforms at top); d) unhafted flake tools (perforators).

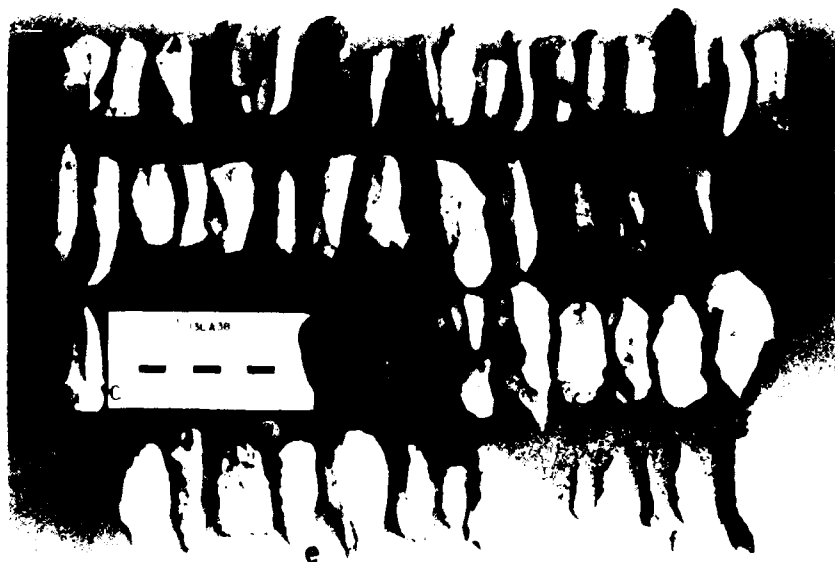

Figure 4.2: Blades from 13LA38 excavations; a) 1-2 ridge scars from Stratum II; b) Y-ridge scars from Stratum II; c) notched from Stratum II; d) multiple scars from Stratum II; e) Stratum III; f) perforators on blades from Stratum II.

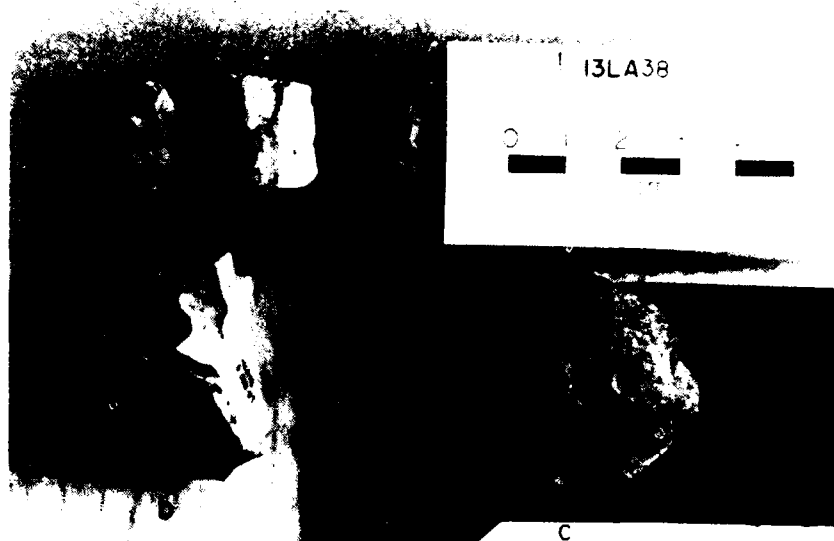

Figure 4.3: a) three gun flints (rt. definite, lt. probable, center ?);  
 b) dihedral blade core from Stratum II; c) disk blade core from  
 Stratum II.

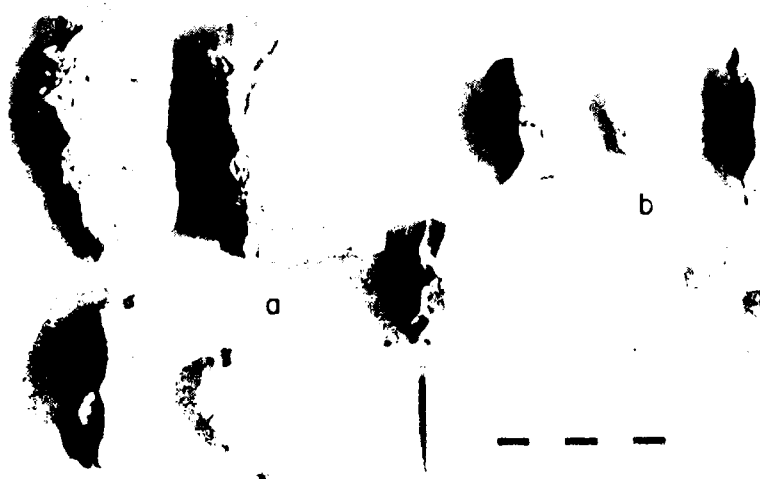

Figure 4.4: Chipped Stone bifaces from Stratum II: a) five secondary  
 bifaces used as digging tools; b) three primary bifaces; c) one  
 secondary biface fragment.



Figure 4.5: Projectile points from Stratum I; a) two Manker Corner Notched; b) four Reed Side Notched; c) Mills or Haskell points; d) Table Rock Pointed Stem; e) Ansell Constricted Stem; f) Marshall Barbed; g) Flake points (second from left is a Madison point); h) unidentified.



Figure 4.6: Chipped stone bifaces; a) two secondary bifaces from Stratum III; b) five secondary bifaces from Stratum III; c) four primary bifaces from Stratum III; d) four primary bifaces used as flaking tools from Stratum III.



Figure 4.7: Bifacial digging tools; a) Stratum II; b) Stratum III.



Figure 4.8: Chipped stone drills from 13LA38; a) narrow bits from Stratum III; b) thick bits from Stratum II; c) Stratum III drills (all bits oriented to top of picture).



Figure 4.9: Stratum II projectile points; a) two Manker Stemmed (left is Knife River flint); b) Steuben Stemmed; c) Snyders Corner Notched variety; d) unidentified; e) two Cedar Valley points; f) Besant-like; g) two Raddatz/Godar-like points; h) Manker Corner Notched (Warsaw Tabular chert with dark red central patch of cortex); i) two Ansell Constricted points; j) four Gibson points.

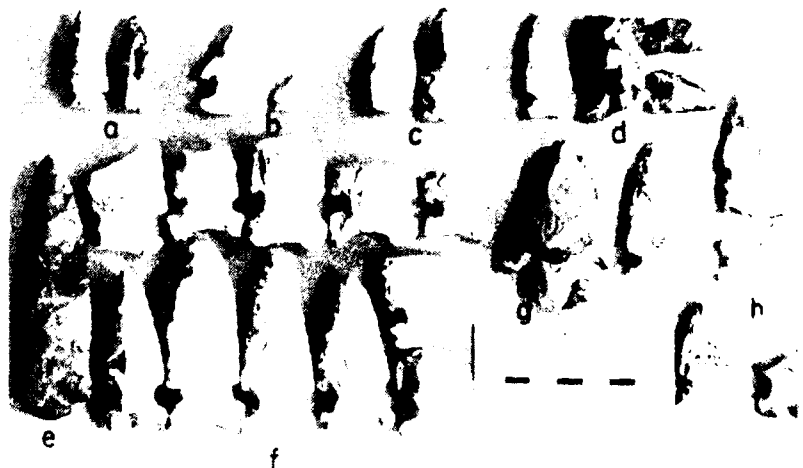

Figure 4.10: Stratum III projectile points; a) two Apple Blossom Stem; b) two Flared Stem Matanzas; c) two Faint Notched Matanzas; d) four Deep Notched Matanzas; e) Etley-like; f) eleven Osceola; g) Helton; h) five Raddatz/Godar points.

Excavation Block (I)	A	B	C	Total
<b>DEBITAGE</b>				
<u>Flake Types</u>	N=558	N=238	N=1202	N=1998
Primary Decortication	1/.02	4/.02	22/.02	27/.01
Secondary Decortication	29/.05	5/.02	57/.05	91/.05
Interior Flake	45/.08	33/.14	109/.09	187/.09
Flake Blanks	12/.02	14/.06	25/.02	51/.03
Primary Thinning	36/.06	23/.10	124/.10	183/.09
Secondary Thinning	226/.40	88/.37	347/.29	661/.33
Tertiary Flake	17/.03	4/.01	18/.02	38/.02
Retouch Flake	6/.01	2/---	9/---	14/---
Angular Shatter	91/.16	24/.10	237/.20	352/.18
Tabular Shatter	5/.01	3/.01	21/.02	29/.01
Flake Fragment	78/.14	49/.20	239/.20	366/.18
Core Rejuvenation Flake	9/.02	3/.01	14/.01	26/.01
Heat Treated	62/.11	28/.12	127/.10	217/.11
<u>Condition</u>				
Whole	254/.45	112/.47	550/.46	916/.46
Distal Fragment	59/.11	17/.07	75/.06	151/.08
Proximal Fragment	39/.07	21/.09	22/.02	82/.04
Unidentifiable	150/.27	56/.23	435/.48	641/.32
<b>TECHNOLOGY AND MORPHOLOGY</b>				
<u>Platform Types</u>	N=297	N=113	N=594	N=1004
Bifacial Edge	1/--	2/--	9/.01	12/.01
Unfaceted	105/.36	51/.45	258/.43	314/.42
Faceted	52/.18	26/.23	26/.04	104/.10
Dihedral	39/.13	14/.12	110/.18	163/.16
Edge Faceting Only	4/.01	3/.02	20/.03	27/.03
Double Facet	1/--	----	3/--	4/--
Pseudo Faceting	64/.21	21/.18	159/.25	244/.24
Grinding	7/.02	2/.01	1/--	10/.01
Single Flake Facet	8/.03	1/--	6/.01	15/.01
<u>Detachment Technique</u>				
Pressure Flaking	N=327	N=134	N=628	N=1089
Pressure Flaking	1/--	5/.03	---	6/--
Softhammer	252/.77	93/.70	432/.69	777/.72
Hardhammer	74/.23	36/.27	196/.32	306/.28
<u>Morphology</u>				
Morphology	N=297	N=132	N=662	N=1091
Expanding	183/.62	74/.56	422/.64	679/.62
Contracting	54/.18	27/.20	127/.19	208/.19
Parallel	60/.20	31/.23	113/.17	204/.19
<u>Configuration</u>				
Configuration	N=275	N=124	N=535	N=934
End Flake	133/.48	60/.48	228/.42	421/.45
Side Flake	142/.52	64/.52	307/.58	513/.55

Table 4.1. Typological, technological and morphological characteristics of the lithic debitage from Stratum I, 13LA38.



Excavation Block (II)	A	B	C	Total
<b>DEBITAGE</b>				
<u>Flake Types</u>	N=177	N=353	N=1279	N=1809
Primary Decortication	2/.01	5/.01	33/.03	40/.02
Secondary Decortication	9/.04	51/.15	196/.15	256/.14
Interior Flake	24/.13	16/.05	91/.07	131/.07
Flake Blanks	---	(1)/.00	(3)/.--	(4)/.--
Primary Thinning	19/.09	46/.13	167/.13	232/.13
Secondary Thinning	70/.40	123/.39	322/.25	515/.28
Tertiary Flake	8/.04	---	---	8/--
Retouch Flake	---	---	---	---
Angular Shatter	20/.11	64/.18	264/.20	348/.19
Tabular Shatter	2/.01	4/.01	31/.02	37/.02
Flake Fragment	20/.11	44/.12	184/.14	228/.12
Core Rejuvenation Flake	3/.01	---	1/--	4/--
Heat Treated	29/.15	65/.18	103/.08	197/.11
<u>Condition</u>				
Whole	93/.51	160/.45	550/.43	803/.44
Distal Fragment	24/.13	43/.12	82/.06	149/.08
Proximal Fragment	15/.08	30/.08	135/.10	180/.10
Medial Fragment	5/.02	8/.02	18/.01	31/.02
Unidentifiable	40/.22	112/.32	494/.39	646/.36
<b>TECHNOLOGY AND MORPHOLOGY</b>				
<u>Platform Types</u>	N=112	N=190	N=687	N=983
Bifacial Edge	---	---	---	---
Unfaceted	67/.60	109/.57	492/.72	667/.68
Faceted	7/.06	14/.07	10/.01	31/.03
Dihedral	7/.06	8/.04	22/.03	37/.03
Edge Faceting Only	7/.05	7/.03	12/.02	26/.02
Double Facet	---	---	3/--	3/--
Pseudo-Faceting	19/.17	51/.27	144/.21	214/.22
Grinding	4/.03	1/--	2/--	6/--
Single Flake Facet	1/.01	---	2/--	4/--
<u>Detachment Technique</u>				
Pressure Flaking	N=139	N=329	N=1182	N=1750
Pressure Flaking	2/.01	---	1/--	3/--
Soft Hammer	82/.59	159/.48	362/.31	603/.34
Hard Hammer	55/.40	170/.52	819/.69	1144/.65
<u>Morphology</u>				
Expanding	N=136	N=221	N=664	N=1021
Expanding	36/.26	53/.24	182/.27	271/.26
Contracting	62/.46	124/.55	359/.54	545/.53
Parallel	38/.28	44/.21	123/.18	205/.20
<u>End Flake</u>				
End Flake	N=135	N=230	N=712	N=1077
End Flake	109/.81	190/.81	531/.75	830/.77
Side Flake	26/.19	40/.19	181/.25	247/.23

Table 4.2. Lithic debitage technological characteristics and types, Stratum II.

Features Stratum II	A	B	Total
<b>DEBITAGE</b>			
<u>Flake Types</u>	N=118	N=189	N=307
Primary Decordication	3/.02	3/.01	6/.02
Secondary Decordication	16/.13	21/.11	37/.12
Interior Flake	9/.07	14/.07	23/.07
Flake Blank	---	---	---
Primary Thinning	7/.05	18/.09	25/.08
Secondary Thinning	55/.46	63/.33	118/.38
Tertiary Flake	---	1/--	1/--
Retouch Flake	---	---	---
Angular Shatter	17/.14	32/.17	49/.16
Tabular Shatter	1/.01	2/.01	3/.01
Flake Fragment	10/.08	35/.18	45/.15
Core Rejuvenation	---	---	---
Heat Treated	11/.09	33/.17	44/.14
<u>Condition</u>			
Whole	61/.51	100/.53	161/.52
Distal Fragment	18/.15	8/.04	26/.08
Proximal Fragment	8/.06	10/.05	18/.06
Medial Fragment	4/.03	---	4/.01
Unidentifiable	27/.22	71/.37	98/.32
<b>TECHNOLOGY AND MORPHOLOGY</b>			
<u>Platform Types</u>	N=69	N=110	N=179
Bifacial Edge	---	---	---
Unfaceted	37/.52	78/.71	115/.64
Faceted	3/.04	5/.04	8/.04
Dihedral	4/.05	5/.04	9/.05
Edge Faceting Only	2/.02	1/.01	3/.02
Double Facet	---	---	---
Pseudo Faceting	23/.34	21/.19	44/.24
Grinding	---	---	---
Single Flake Facet	---	---	---
<u>Detachment Technique</u>			
Pressure Flaking	N=111	N=183	N=294
Softhammer	60/.54	86/.47	146/.49
Hardhammer	51/.46	97/.53	148/.51
<u>Morphology.</u>	N=90	N=112	N=202
Expanding	18/.20	38/.34	56/.28
Contracting	36/.40	51/.45	87/.43
Parallel	36/.40	23/.20	59/.29
	N=87	N=115	N=202
End Flake	75/.86	85/.74	160/.79
Side Flake	12/.14	30/.26	42/.21

Table 4.3. Lithic debitage characteristics and types from Stratum II features.

Excavation Block III				
DEBITAGE	A	B	C	Total
	N=4	N=407	N=1459	N=1870
<u>Flake Types</u>				
Primary Decordication	---	8/.02	77/.05	85/.04
Secondary Decordication	2/.50	52/.12	150/.10	204/.11
Interior Flake	1/.25	38/.09	144/.10	183/.10
Flake Blank	(1).25	(10).02	(13).01	(24).01
Primary Thinning	---	68/.16	211/.14	279/.15
Secondary Thinning	1/.25	80/.20	405/.27	486/.26
Tertiary Flake	---	2/.01	4/.--	6/.--
Retouch Flake	---	---	1/.--	1/.--
Angular Shatter	---	91/.22	217/.15	308/.16
Tabular Shatter	---	4/.01	31/.02	35/.02
Flake Fragment	---	64/.16	219/.15	283/.15
Core Rejuvenation	---	---	---	---
Heat Treated	---	25/.06	133/.09	158/.08
<u>Condition</u>				
Whole	1/.25	173/.43	683/.46	857/.46
Distal Fragment	1/.25	22/.05	101/.47	124/.07
Proximal Fragment	1/.25	48/.11	182/.13	231/.12
Medial Fragment	---	2/.01	18/.01	20/.01
Unidentifiable	1/.2	162/.41	475/.33	538/.29
TECHNOLOGY AND MORPHOLOGY				
<u>Platform Types</u>				
	N=2	N=221	N=865	N=1088
Bifacial Edge	---	---	1/.--	1/.--
Unfaceted	2/100	171/.79	647/.75	820/.75
Faceted	---	---	6/.01	6/.--
Dihedral	---	5/.02	15/.02	20/.02
Edge Faceting Only	---	5/.02	47/.05	52/.05
Double Facet	---	1/.--	---	1/.--
Pseudo Faceting	---	39/.17	149/.17	188/.17
Grinding	---	---	---	---
Single Flake Facet	---	---	1/.--	1/.--
<u>Detachment Technique</u>				
	N=4	N=387	N=1440	N=1831
Pressure Flaking	---	1/.--	4/.--	5/.--
Softhammer	1/.25	119/.31	473/.32	593/.32
Hardhammer	3/.75	267/.69	963/.68	1233/.68
<u>Morphology</u>				
	N=3	N=199	N=794	N=996
Expanding	1/.33	49/.22	198/.25	248/.25
Contracting	2/.66	127/.61	526/.66	655/.66
Parallel	---	23/.11	70/.09	93/.09
	N=4	N=183	N=867	N=1054
End Flake	3/.75	138/.77	567/.65	708/.67
Side Flake	1/.25	45/.23	300/.35	346/.33

Table 4.4. Lithic debitage technological characteristics and types, Stratum III.

Lithic Debitage: Features Stratum III

Excavation Block	B	C	Total
<u>Flake Types</u>	N=70	N=130	N=200
Primary Decordication	1/.01	4/.03	5/.02
Secondary Decordication	12/.17	19/.14	31/.15
Interior	12/.17	19/.14	31/.15
Flake Blank	(2).02	(3).01	(5).02
Primary Thinning	6/.08	15/.12	21/.10
Secondary Thinning	16/.23	30/.23	46/.23
Tertiary Flake	1/.01	---	1/.--
Retouch Flake	---	---	---
Angular Shatter	15/.23	16/.13	31/.15
Tabular Shatter	3/.04	11/.09	14/.07
Flake Fragment	4/.06	16/.13	20/.10
Core Rejuvenation Flake	---	---	---
Heat Treated	7/.10	8/.05	15/.07
<u>Condition</u>			
Whole	38/.54	60/.45	98/.49
Distal Fragment	2/.02	8/.06	10/.05
Proximal Fragment	6/.08	17/.13	23/.11
Medial Fragment	2/.02	2/.01	4/.02
Unidentifiable	22/.31	43/.35	65/.32
<u>TECHNOLOGY AND MORPHOLOGY</u>			
<u>Platform Types</u>	N=44	N=77	N=121
Bifacial Edge	---	---	---
Unfaceted	37/.67	56/.74	93/.77
Faceted	1/.02	---	1/.01
Dihedral	---	---	---
Edge Faceting Only	1/.02	2/.03	3/.02
Double Faceted	---	---	---
Pseudo Faceting	5/.08	19/.23	24/.20
Grinding	---	---	---
Single Flake Facet	---	---	---
<u>Detachment Technique</u>	N=70	N=130	N=200
Pressure Flaking	---	---	---
Soft Hammer	22/.31	37/.28	59/.29
Hard Hammer	48/.69	93/.72	141/.71
<u>Morphology</u>	N=40	N=69	N=109
Expanding	12/.30	16/.24	28/.26
Contracting	22/.55	48/.68	70/.72
Parallel	6/.15	5/.08	11/.10
	N=45	N=76	N=121
End Flake	37/.82	50/.66	87/.72
Side Flake	8/.18	26/.34	34/.28

Table 4.5. Lithic debitage technological characteristics and types, Stratum III features.

Stratum	I	II	III	Total
<b>DEBITAGE TOTALS</b>				
<u>Flake Types</u>	N=1998	N=1809	N=1870	N=5677
Primary Decortication	27/.01	40/.02	85/.04	152/.03
Secondary Decortication	91/.05	256/.14	204/.11	551/.10
Interior Flake	187/.09	131/.07	183/.10	501/.09
Flake Blanks	51/.03	(4)/.--	(24)/.01	(79)/.01
Primary Thinning	183/.09	232/.13	279/.15	694/.12
Secondary Thinning	661/.33	515/.28	486/.26	1662/.29
Tertiary Flake	38/.02	8/--	6/--	52/--
Retouch Flake	14/--	----	----	14/--
Angular Shatter	352/.18	348/.19	308/.16	1008/.18
Tabular Shatter	29/.01	37/.02	35/.02	101/.02
Flake Fragment	366/.18	228/.12	283/.15	877/.15
Core Rejuvenation Flake	26/.01	4/--	----	30/--
Heat Treated	217/.11	197/.11	158/.08	572/.10
<u>Condition</u>				
Whole	916/.46	803/.44	857/.46	2576/.45
Distal Fragment	151/.08	149/.08	124/.07	424/.07
Proximal Fragment	82/.04	180/.10	231/.12	493/.09
Medial Fragment	121/.06	31/.02	20/.01	172/.03
Unidentifiable	641/.32	646/.36	538/.29	1825/.32
<b>TECHNOLOGY AND MORPHOLOGY</b>				
<u>Platform Types</u>	N=1004	N=983	N=1088	N=3075
Bifacial Edge	12/.01	----	----	----
Unfaceted	314/.42	667/.68	820/.75	1801/.59
Faceted	104/.10	31/.03	6/--	141/.05
Dihedral	163/.16	37/.03	20/.02	220/.07
Edge Faceting Only	27/.03	26/.02	52/.05	105/.03
Double Facet	4/--	3/--	1/--	8/--
Pseudo Faceting	244/.24	214/.22	188/.17	646/.21
Grinding	10/.01	6/--	----	16/--
Single Flake Facet	15/.01	4/--	1/--	20/--
<u>Detachment Technique</u>	N=1089	N=1750	N=1831	N=4670
Pressure Flaking	6/--	3/--	5/--	14/--
Softhammer	777/.72	603/.34	593/.32	1973/.42
Hardhammer	306/.28	1144/.65	1233/.68	2683/.57
<u>Morphology</u>	N=1091	N=1021	N=996	N=3108
Expanding	679/.62	271/.26	248/.25	1198/.38
Contracting	208/.19	545/.53	655/.66	1408/.45
Parallel	204/.19	205/.20	93/.09	502/.16
	N=934	N=1077	N=1054	N=3065
End Flake	421/.45	830/.77	708/.67	1959/.64
Side Flake	513/.55	247/.23	346/.33	1106/.36

Table 4.6. Typological, technological and morphological characteristics of the lithic debitage from three strata (I, II, III), 13LA38.

Excavation Block	A	B	C	Total
<u>Stratum II</u>	<u>N=177</u>	<u>N=353</u>	<u>N=1279</u>	<u>N=1809</u>
Burlington Chert	153/.86	309/.87	1159/.87	1621/.87
Igneous Rock	---	---	---	---
BGW Speckled Chert	8/.04	15/.04	85/.06	108/.06
Dark Red Chert	1/--	1/--	---	2/--
Warsaw Tabular	15/.09	27/.08	24/.02	66/.04
Winterset Chert	---	---	1/--	1/--
Quartz	---	1/--	9/--	10/--
Cobden	---	---	1/--	1/--
<u>Features: Stratum II</u>	<u>N=118</u>	<u>N=189</u>	<u>---</u>	<u>N=307</u>
Burlington Chert	107/.89	164/.85	---	271/.86
Igneous Rock	---	---	---	---
BGW Speckled Chert	2/.01	9/.05	---	11/.03
Dark Red Chert	2/.01	2/.01	---	4/.01
Warsaw Tabular	7/.05	14/.07	---	21/.07
<u>Stratum III</u>	<u>N=4</u>	<u>N=407</u>	<u>N=1459</u>	<u>N=1870</u>
Burlington Chert	4/100	359/.88	1238/.85	1702/.90
BGW Speckled Chert	---	34/.08	73/.05	107/.06
Warsaw Tabular	---	2/.01	14/.01	16/.01
Dark Red Chert	---	4/.01	7/--	12/--
Cobden	---	---	2/--	2/--
Quartz	---	2/.01	1/--	3/--
Rose-pink Banded	---	2/.01	22/.02	24/.01
Tan, Blue White Speckled	---	4/.01	---	4/--
<u>Features: Stratum III</u>	<u>N=0</u>	<u>N=70</u>	<u>N=130</u>	<u>N=200</u>
Burlington Chert	---	62/.87	119/.89	181/.88
BGW Speckled Chert	---	7/.10	4/.04	11/.05
Dark Red Chert	---	1/.01	2/.02	3/.01
Cobden	---	---	1/.01	1/--
Quartz	---	1/.01	---	1/--
Tan-blue Speckled Chert	---	3/.03	---	3/.01

Table 4.7. Lithic debitage chert types.

CORES

Block Excavation Stratum	A			B			C			Total		
	I	II	III	I	II	III	I	II	III	I	II	III
Double-Platform	2	0	---	1	2	4	4	1	7	7	3	11
Single-Plat-Tabular	1	0	---	0	1	0	1	2	0	2	3	0
Single-Platform	0	0	---	0	0	1	0	0	0	0	1	1
Polymorphic	1	0	---	0	0	1	0	0	2	1	0	3
Pyramidal	3	0	---	1	0	1	4	3	4	8	3	5
Discoidal	0	0	---	2	0	0	1	0	0	3	0	0
Blade Cores	0	0	---	0	2	0	0	0	0	0	0	0
Tested Cobbles	0	1	---	1	0	0	2	3	0	3	1	0
Exhausted Cores	0	0	---	0	0	2	0	0	3	0	0	5
Core Fragments	2	5	---	1	6	14	4	12	9	7	24	23
<b>Total</b>	<b>9</b>	<b>6</b>	<b>---</b>	<b>6</b>	<b>11</b>	<b>23</b>	<b>16</b>	<b>21</b>	<b>25</b>	<b>31</b>	<b>38</b>	<b>48</b>

Core Weights in grams (# of specimens)

Grams	>80	50-80	25-50	<25	TOTAL
Stratum I	2	5	9	15	31
Stratum II	3	6	9	20	38
Stratum III	13	8	20	7	48
<b>Totals</b>	<b>18</b>	<b>19</b>	<b>38</b>	<b>42</b>	<b>117</b>

Table 4.8. Core types, weights, and block distributions from 13LA38.

Excavation Block (I)	A	B	C	Total
<u>Flake Types</u>	N=56	N=19	N=65	N=140
Primary Decortication	1/.02	1/.05	3/.05	5/.03
Secondary Decortication	4/.07	2/.10	11/.17	17/.12
Interior Flake	32/.56	13/.65	29/.47	73/.52
Primary Thinning	7/.12	1/.05	3/.05	11/.08
Secondary Thinning	7/.12	2/.10	8/.12	17/.12
Tertiary Flake	----	----	----	----
Tabular Shatter	3/.05	1/.05	2/.04	6/.05
Angular Shatter	----	----	2/.02	2/----
Flake Fragment	1/.02	----	6/.09	7/.05
Natural Flake	1/.02	----	1/.02	2/.01
Heat Treated	16/.29	3/.16	17/.26	36/.26
Levallois Flake	4/.07	----	----	4/.03
<u>Condition</u>				
Whole	39/.70	9/.47	39/.60	87/.62
Proximal	3/.05	1/.05	8/.12	12/.09
Distal	10/.18	7/.37	6/.09	23/.16
Medial	1/.07	----	5/.08	6/.04
Unidentifiable	3/.05	2/.11	7/.13	12/.09
<u>TECHNOLOGY AND MORPHOLOGY</u>				
<u>Platform Types</u>	N=39	N=10	N=44	N=89
Bifacial Tool Edge	----	----	----	----
Unfaceted	18/.51	3/.30	19/.43	40/.45
Faceted	2/.06	2/.20	7/.16	11/.12
Dihedral	4/.11	2/.20	5/.11	11/.12
Edge Faceting Only	2/.06	1/.10	4/.10	7/.08
Double Facet	----	----	----	----
Pseudo-Faceting	8/.23	2/.20	8/.18	18/.20
Grinding	1/.03	----	2/.04	2/.02
<u>Detachment Technique</u>	N=50	N=13	N=51	N=114
Softhammer	19/.38	4/.31	18/.35	41/.36
Hardhammer	31/.62	9/.29	33/.65	73/.64
<u>Morphology</u>	N=41	N=12	N=49	N=102
End Flake	27/.66	7/.59	29/.59	63/.62
Side Flake	14/.	5/.41	20/.41	39/.38

Table 4.9. Total number and percentages of the technological and morphological characteristics of unhafted flakes tools, Stratum I, 13LA38.



Chert Types: Unhafted Flake Tools

Excavation Block	A	B	C	TOTAL
	N=56	N=19	N=65	N=140
Burlington Chert	51/.91	15/.79	61/.94	127/.91
Igneous Rocks	----	----	1/.02	1/----
BGW Speckled	1/.02	1/.05	1/.02	3/.02
RGB Chert	----	----	----	----
Moline Chert	1/.02	1/.05	2/.04	4/.03
Warsaw Chert	1/.02	----	----	1/----

Excavation Block	A	B	C	TOTAL
<u>Tool Type</u>	N=56	N=19	N=65	N=140
Knife (scraping)	22/.39	9/.47	25/.38	56/.40
Knife (cutting)	27/.48	9/.47	28/.43	64/.46
Backed Knife	4/.07	1/.06	3/.06	8/.06
Spokeshave	----	----	1/.02	1/----
Perforator	1/.02	----	7/.13	8/.06
Hide Scraper	----	----	1/.02	1/----
<u>Retouch and Wear</u>				
Bifacial Retouch	3/.05	2/.11	----	5/.03
Unifacial Retouch	8/.14	3/.16	11/.17	22/.16
Unifacial Wear	25/.45	10/.53	26/.40	61/.44
Bifacial Wear	30/.54	9/.47	37/.57	76/.54

Table 4.10. Chert types and unhafted flake tool types from Stratum I, 13LA38.

Unhafted Flake Tools: Stratum II

Excavation Block	A	B	C	Total
<u>Flake Types</u>	N=20	N=43	N=82	N=145
Primary Decortication	1/.05	5/.12	6/.07	12/.08
Secondary Decortication	3/.15	4/.16	23/.28	30/.21
Interior Flake	8/.40	17/.40	24/.29	49/.34
Primary Thinning	3/.15	8/.19	4/.05	16/.11
Secondary Thinning	5/.25	3/.07	13/.16	21/.14
Tertiary Flake	---	---	---	---
Tabular Shatter	---	---	---	---
Angular Shatter	1/.05	---	2/.05	3/.02
Flake Fragment	---	6/.14	9/.11	15/.10
Natural Flake	---	---	---	---
Heat Treated	3/.15	7/.16	14/.17	19/.13
Levallois Flake	---	---	---	---
<u>Condition</u>				
Whole	17/.85	27/.63	45/.55	89/.61
Proximal Fragment	2/.17	1/.02	11/.13	14/.10
Distal Fragment	---	9/.21	11/.13	20/.14
Medial Fragment	1/.05	4/.09	4/.05	9/.06
Unidentifiable	---	2/.05	11/.13	13/.09
<u>Platform Types</u>	N=19	N=28	N=56	N=103
Bifacial Tool Edge	---	---	---	---
Unfaceted	5/.26	14/.50	28/.50	39/.38
Faceted	3/.16	4/.14	2/.04	9/.02
Dihedral	4/.21	2/.07	4/.07	10/.10
Edge Faceting	2/.11	---	1/--	3/.03
Double Facet	---	---	---	---
Pseudo-Faceted	5/.26	8/.29	20/.36	33/.32
Edge Grinding	---	---	---	---
<u>Detachment Technique</u>	N=19	N=29	N=72	N=120
Softhammer	7/.37	8/.27	19/.26	34/.28
Hardhammer	12/.63	21/.73	53/.74	86/.72
	N=18	N=36	N=59	N=113
Side Flake	10/.71	15/.42	28/.48	53/.47
End Flake	8/.57	21/.58	31/.52	60/.53

Table 4.11. Technological characteristics associated with unhafted flake tools recovered from Stratum II, 13LA38.

Unhafted Flake Tool Uses and Chert Types: Stratum II

Excavation Block	A	B	C	Total
<u>Tool Use</u>	N=20	N=43	N=82	N=145
Knife (scraping)	14/.70	31/.72	23/.28	91/.63
Knife (cutting)	12/.60	29/.67	61/.74	102/.70
Backed Knife	2/.10	2/.05	---	5/.03
Spokeshave	---	---	---	---
Perforator	---	3/.07	4/.05	7/.05
Hide Scraper	---	---	---	1/--
Graver	---	---	3/.04	3/.02
<u>Retouch and Wear</u>				
Bifacial Retouch	---	4/.09	9/.11	13/.09
Unifacial Retouch	4/.20	3/.05	39/.48	46/.52
Unifacial Wear	8/.40	18/.42	30/.37	56/.39
Bifacial Wear	12/.60	31/.72	41/.50	84/.95
<u>Chert Types</u>				
Burlington Chert	17/.85	27/.62	84/.67	114/.79
BGW Speckled Chert	1/.05	12/.14	6/.16	19/.13
Warsaw Tabular Chert	1/.05	4/.04	3/.08	8/.05
Winterset Chert	1/.05	---	---	1/--
Cobden Chert	---	---	2/.05	2/.02
Igneous Rock	---	---	1/.03	1/--

Table 4.12. Tool uses, retouch, wear, and chert types of the unhafted flake tools from Stratum II, 13LA38.

Unhafted Flake Tools: Stratum III

Excavation Block	A	B	C	Total
<u>Flake Types</u>	N=1	N=46	N=142	N=189
Primary Decortication	---	---	12/.09	12/.06
Secondary Decortication	1	15/.33	41/.29	56/.42
Interior Flake	---	13/.28	23/.16	36/.19
Primary Thinning Flake	---	8/.17	26/.18	34/.18
Secondary Thinning Flake	---	3/.07	7/.05	10/.15
Tertiary Flake	---	---	---	---
Tabular Shatter	---	---	1/--	1/--
Angular Shatter	---	1/.02	2/.01	3/.02
Flake Fragment	---	6/.13	30/.21	36/.27
Natural Flake	---	---	---	---
Heat Treated	---	2/.02	22/.15	24/.18
Levallois Flake	---	---	---	---
<u>Condition</u>				
Whole	1	27/.59	69/.47	97/.73
Proximal Fragment	---	9/.20	22/.15	31/.24
Distal Fragment	---	5/.05	18/.13	23/.26
Medial Fragment	---	1/.02	4/.02	5/.04
Unidentifiable	---	5/.08	29/.20	34/.26
<u>Platform Types</u>	N=1	N=36	N=91	N=128
Bifacial Tool Edge	---	---	---	---
Unfaceted	1	11/.30	34/.37	46/.40
Faceted	---	2/.05	---	2/.02
Dihedral	---	4/.11	3/.03	7/.05
Edge Faceting	---	6/.17	19/.21	24/.20
Double Facet	---	---	---	---
Pseudo-Faceted	---	13/.36	35/.38	48/.37
Edge Grinding	---	---	---	---
<u>Detachment Technique</u>	N=1	N=43	N=114	N=158
Softhammer	1	10/.28	28/.29	45/.28
Hardhammer	---	29/.67	83/.73	113/.72
	N=1	N=35	N=97	N=133
Side Flake	---	10/.28	28/.29	38/.28
End Flake	1	25/.72	69/.71	95/.72

Table 4.13. Technological characteristics associated with unhafted flake tools from Stratum III, 13LA38

AD-A184 290    ARCHAEOLOGY IN THE MISSISSIPPI RIVER FLOODPLAIN AT SAND 3/4

RUN SLOUGH IOWA(U) SOUTHWEST MISSOURI STATE UNIV

SPRINGFIELD CENTER FOR ARCHAEOLOGY    D W BERN ET AL

UNCLASSIFIED

JUN 87 CAR-698 DACW25-86-C-0025

F/G 5/6

NL

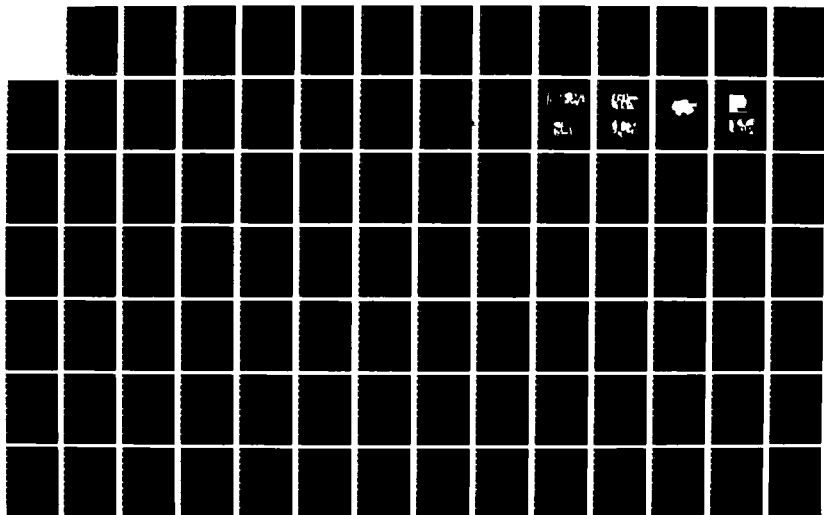

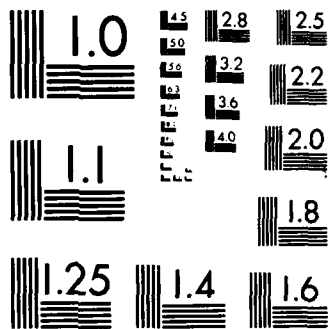

MICROCOPY RESOLUTION TEST CHART  
NATIONAL BUREAU OF STANDARDS-1963-A

Unhafted Flake Tools: Stratum III

Excavation Block <u>Tool Use</u>	A N=1	B N=46	C N=142	Total N=189
Knife (scraping)	---	12/.26	52/.37	64/.34
Knife (cutting)	1	31/.67	71/.50	103/.54
Backed Knife	---	---	---	---
Spokeshave	---	1/.02	2/.01	3/.02
Perforator	---	---	6/.04	6/.03
Hide Scraper	---	1/.02	2/.01	3/.02
Graver	---	8/.17	40/.28	48/.25
 <u>Retouch and Wear</u>				
Bifacial Retouch	---	6/.13	21/.15	27/.14
Unifacial Retouch	1	35/.76	95/.67	131/.69
Unifacial Wear	1	35/.76	93/.65	129/.68
Bifacial Wear	---	18/.39	61/.43	76/.43
 <u>Chert Types</u>				
Burlington Chert	1	41/.89	129/.91	170/.90
BGW Speckled	---	4/.07	12/.10	16/.08
Igneous Rock	---	---	1/--	1/--
Quartz	---	---	1/--	1/--

Table 4.14. Tool uses, retouch, wear, and chert types of the unhafted flake tools from Stratum II, 13LA38.

Stratum	I	II	III	Total
<u>Flake Types</u>	N=140	N=145	N=189	N=474
Primary Decortication	5/.03	12/.08	12/.06	29/.06
Secondary Decortication	17/.12	30/.21	56/.30	103/.22
Interior Flake	73/.52	49/.34	36/.19	158/.33
Primary Thinning	11/.08	16/.11	34/.18	61/.13
Secondary Thinning	17/.12	21/.14	10/.15	48/.10
Tertiary Flake	----	----	----	----
Tabular Shatter	6/.05	----	----	6/.01
Angular Shatter	2/----	3/.02	3/.02	8/.02
Flake Fragment	7/.05	15/.10	36/.27	58/.12
Natural Flake	2/.01	----	----	2/----
Heat Treated	36/.26	19/.13	24/.18	79/.17
Levallois Flake	4/.03	----	----	4/----
<u>Condition</u>				
Whole	87/.62	89/.61	97/.73	273/.58
Proximal	12/.09	14/.10	31/.24	57/.12
Distal	23/.16	20/.14	23/.26	66/.14
Medial	6/.04	9/.06	5/.04	20/.04
Unidentifiable	12/.09	13/.09	34/.26	59/.12
<b>TECHNOLOGY AND MORPHOLOGY</b>				
<u>Platform Types</u>	N=89	N=103	N=128	N=320
Bifacial Tool Edge	----	----	----	----
Unfaceted	40/.45	39/.38	46/.36	125/.39
Faceted	11/.12	9/.02	2/.02	22/.07
Dihedral	11/.12	10/.10	7/.05	28/.09
Edge Faceting Only	7/.08	3/.03	24/.20	34/.11
Double Facet	----	----	----	----
Pseudo-Faceting	18/.20	33/.32	48/.37	99/.31
Grinding	2/.02	----	----	2/----
<u>Detachment Technique</u>	N=114	N=120	N=158	N=392
Softhammer	41/.36	34/.28	45/.28	120/.31
Hardhammer	73/.64	86/.72	113/.72	272/.69
<u>Configuration</u>	N=102	N=113	N=133	N=348
End Flake	63/.62	53/.47	38/.28	154/.44
Side Flake	39/.38	60/.53	95/.72	194/.56

Table 4.15: Total number and percentages of the technological and morphological characteristics of unhafted flake tools, all strata, 13LA38.



Unhafted Flake Tool Dimensions

Block A: Stratum I					
	Total	Mean	SD	Max.	Min.
N=56					
Length	39	2.9	1.1	5.3	1.4
Width	52	2.4	.7	4.2	1.1
Thickness	56	.6	.3	1.1	.2
Edge Angle	56	37	15	80	22 degrees
Block B: Stratum I					
	Total	Mean	SD	Max.	Min.
N=19					
Length	9	2.8	1.3	4.5	1.0
Width	18	2.6	.9	4.6	1.2
Thickness	19	.7	.4	1.8	.2
Edge Angle	19	36	11	58	22 degrees
Block C: Stratum I					
	Total	Mean	SD	Max.	Min.
N=65					
Length	45	3.0	.9	5.0	1.6
Width	60	2.6	1.0	6.8	1.3
Thickness	65	.7	.3	1.5	.3
Edge Angle	65	41	15	70	22 degrees
Overall: Stratum I					
	Total	Mean	SD	Max.	Min.
N=140					
Length	84	3.0	.9	5.3	1.0
Width	119	2.6	.9	6.8	1.1
Thickness	140	.6	.3	1.8	.2
Edge Angle	140	39	15	80	22 degrees

Table 4.16: Dimensions of unhafted flake tools from Stratum I, 13LA38. All measurements in centimeters, except for edge angles in degrees.

Unhafted Flake Tool Dimensions: Stratum II

Block A: Stratum II

	Total	Mean	SD	Max.	Min.
N=20					
Length	17	3.0	1.0	5.2	1.9
Width	20	2.5	.9	5.2	1.2
Thickness	20	.7	.4	1.9	.2
Edge Angle	20	40	15	72	24 degrees

Block B: Stratum II

	Total	Mean	SD	Max.	Min.
N=43					
Length	27	3.0	1.0	6.4	1.7
Width	40	2.4	.7	4.1	1.1
Thickness	43	.6	.3	1.3	.2
Edge Angle	43	36	10	69	22

Block C: Stratum II

	Total	Mean	SD	Max.	Min.
N=82					
Length	46	3.0	1.3	5.4	1.0
Width	66	2.8	1.2	6.6	1.2
Thickness	82	.7	.4	1.8	.2
Edge Angle	82	35	12	75	22

Overall: Stratum II

	Total	Mean	SD	Max.	Min.
N=145					
Length	90	3.0	1.1	6.4	1.0
Width	124	2.6	1.0	6.6	1.1
Thickness	145	.7	.4	2.0	.1
Edge Angle	145	36	12	75	22

Table 4.17: Dimensions of unhafted flake tools from Stratum II, 13LA38.

Unhafted Flake Tool Dimensions: Stratum III

Block B: Stratum III					
N=46	Total	Mean	SD	Max.	Min.
Length	28	3.1	.9	4.5	1.3
Width	39	2.5	.9	5.2	1.1
Thickness	47	.6	.4	1.9	.2
Edge Angle	47	40	16	89	20
Block C: Stratum III					
N=142	Total	Mean	SD	Max.	Min.
Length	69	3.4	1.1	5.7	1.7
Width	98	3.1	1.1	7.1	.8
Thickness	142	.7	.4	1.8	.1
Edge Angle	142	47	15	78	22
Overall: Stratum III					
N=189	Total	Mean	SD	Max.	Min.
Length	97	3.3	1.0	5.7	1.7
Width	137	2.9	1.1	7.1	.8
Thickness	189	.7	.4	1.9	.1
Edge Angle	189	45	16	89	20

Table 4.18: Dimensions of unhafted flake tools from Stratum III, 13LA38.

Hafted Flake Tools: Stratum I

<u>Overall Dimensions</u>					
N=18	TOTAL	MEAN	STANDARD DIVIATION	MOST	LEAST
Length	18	2.55	.6	3.9	1.4
Width	18	1.41	.2	1.7	1.0
Thickness	18	.31	.12	.7	.2
Excavation Block		A	B	C	TOTAL
<u>Flake Types</u>		1	3	14	18
Primary Flake	---	---	---	---	---
Secondary Flake	---	---	---	1	1
Interior Flake		1	3	13	17
Blade		1	2	5	8
Flake	---	---	1	9	10
Contracting	---	---	1	6	7
Expanding	---	---	---	2	2
Parallel		1	2	2	5
<u>Chert Type</u>					
Burlington Chert		1	1	12	14
Peach/Burlington	---	---	---	1	1
BGW Chert	---	---	2	1	3

Table 4.19: Hafted flake tool chert type, blank types and dimensions, Stratum I, 13LA38.

Technology

Excavation Block	A	B	C	TOTAL
<u>Platform Types</u>	N= 1	3	14	18
Bifacial Edge	---	---	---	---
Unfaceted	1	---	2	3
Faceted	---	2	4	6
Dihedral	---	---	1	1
Edge Faceting Only	---	---	2	2
Double Facet	---	---	1	1
Pseudo-Faceted	---	---	3	3
Grinding	---	1	3	4
Softhammer	1	3	14	18
<u>Hafting</u>				
Notching	---	---	3	3
Stemmed	1	2	7	10
Grinding	1	1	5	7
Proximal	1	2	11	14
Distal	---	---	---	---
Lateral Edge	---	---	---	---
<u>Other Characteristics</u>				
Backing	---	---	1	1
Heat Treated	---	---	5	5
Single Dorsal Ridge	---	2	10	12
Double Dorsal Ridge	1	1	3	5
<u>Tool Type</u>				
Knife (scraping)	---	1	9	10
Knife (cutting)	1	---	3	4
Perforator	---	1	3	4
<u>Retouch and Wear</u>				
Bifacial Retouch	---	---	---	---
Unifacial Retouch	---	---	---	---
Bifacial Wear	---	1	12	13
Unifacial Wear	1	1	2	4

Table 4.20: Technological characteristics associated with hafted flake tools from Stratum I, 13LA38.

Blade Characteristics: Strata II & III						
N=	14	18	47	42	7	128
Provenience	AII	BII	B(F)II	CII	CIII	Total
<u>Morphology</u>						
Expanding	2/.14	----	12/.26	7/.17	2/---	23/.18
Parallel	10/.72	10/.55	26/.55	17/.40	4/---	67/.52
Contracting	2/.14	5/.28	8/.17	17/.40	1/---	33/.26
<u>Platform Type</u>						
Multi-faceted	----	----	5/.11	3/.07	2/---	10/.08
Single facet	----	----	1/.02	1/.02	----	2/.02
Edge faceting	7/.50	----	19/.40	11/.26	1/---	38/.30
Dihedral	1/.07	1/.05	1/.01	2/.04	2/---	2/.05
Unfaceted	2/.14	2/.11	8/.17	11/.23	1/---	24/.19
Pseudo-faceted	3/.21	4/.22	10/.21	9/.21	1/---	27/.21
Grinding	8/.57	8/.44	16/.34	11/.23	3/---	46/.36
<u>Haft Element</u>						
Notched	----	----	2/.04	----	----	2/.01
Stemmed	3/.21	9/.50	16/.34	14/.33	4/---	46/.36
Edge flaking	----	2/.11	11/.23	7/.17	2/---	22/.17
Edge grinding	2/.14	7/.39	13/.28	13/.31	3/---	40/.31
Bulbar thinning	----	3/.17	4/.09	3/.07	----	14/.11
Proximal haft	3/.21	8/.44	19/.40	12/.28	3/---	45/.35
Distal haft	----	1/.05	----	1/.01	----	2/.02
Unhafted	11/.78	9/.50	21/.45	18/.43	----	59/.46
<u>Miscellaneous</u>						
Double bulb	----	----	1/.01	----	----	1/---
Backing	1/.07	----	----	2/.04	----	3/.02
Retouched	1/.07	1/.05	3/.06	1/.02	----	6/.05
<u>Detachment</u>						
Hardhammer	2/.14	----	3/.06	----	----	5/.04
Softhammer	12/.86	14/.78	43/.91	42/.100	7/---	118/.92
<u>Dorsal Surface</u>						
Triple ridge	----	----	2/.04	1/.02	----	3/.02
Double ridge	5/.36	5/.28	9/.19	11/.26	----	30/.23
Single ridge	6/.43	7/.39	20/.42	21/.50	2/---	56/.44
Y-shape	1/.07	1/.05	10/.21	7/.17	3/---	22/.17
X-shape	1/.07	----	4/.09	2/.04	1/---	8/.06
V-shape	1/.07	1/.05	1/.02	----	1/---	4/.03
<u>Condition</u>						
Whole	11/.78	13/.72	34/.72	30/.71	7/---	95/.74
Medial fragment	1/.07	----	3/.06	1/.02	----	5/.04
Distal fragment	----	----	5/.11	5/.12	----	10/.08
Proximal fragment	2/.14	5/.28	5/.11	5/.12	----	17/.13
<u>Flake Type</u>						
Decortication	3/.21	1/.05	7/.15	5/.12	----	15/.12
Interior flake	11/.78	17/.94	40/.85	36/.86	7/---	111/.87

Table 4.21: Attributes defining the blade industry at 13LA38.

Dimensions of Blades from 13LA38

Block A (II)	Total	Mean	SD	Max.	Min.
Length	11	3.4	.6	4.4	2.8
Width	14	1.6	.4	2.6	.9
Thickness	14	.4	.2	.8	.2
Block B II					
Length	14	3.4	.8	5.1	2.1
Width	18	1.5	.4	2.0	1.0
Thickness	18	.4	.2	1.0	.2
Block B II (Fea.)					
Length	34	3.8	.8	5.2	2.3
Width	47	1.8	.5	3.4	.9
Thickness	47	.4	.1	.7	.2
Block C II					
Length	30	3.0	.7	4.2	2.1
Width	42	1.5	.4	2.4	.9
Thickness	42	.3	.1	.7	.2
Blocks B & C III					
Length	7	4.0	.5	4.9	3.5
Width	7	1.7	.4	2.3	1.1
Thickness	7	.4	.1	.5	.3
All Blades					
Length	96	3.4	.8	5.2	2.1
Width	128	1.6	.5	3.4	.9
Thickness	128	.4	.1	.8	.2

Blade use and chert types.

Provenience	AII	BII	BFII	CII	III	Total
<u>Tool Use</u>	N=14	N=18	N=47	N=42	N=7	N=128
Knife (cutting)	8/.57	5/.28	27/.57	31/.74	6/-.	77/.60
Knife (scraping)	7/.50	6/.33	29/.62	19/.45	5/-.	76/.59
Spokeshave	1/.07	----	----	1/.02	----	2/.01
Perforator	----	----	----	1/.02	----	1/-.
Hide Scraper	----	----	----	----	----	----
Drill	----	4/.22	2/.04	----	----	6/.05
Graver	----	1/.05	3/.06	2/.04	----	6/.05
No Use-wear	1/.07	5/.28	12/.25	5/.12	----	23/.18
<u>Chert Types</u>						
Burlington	12/.86	16/.89	37/.77	38/.90	7/-.	110/.86
Cobden	----	1/.05	1/.02	1/.02	----	3/.02
Warsaw	----	1/.05	3/.06	----	----	4/.03
BGM Speckled	2/.14	----	6/.13	3/.07	----	11/.08
Heat Treated	8/.57	12/.67	33/.70	28/.67	4/-.	85/.66

Table 4.22: Dimensions, chert types and uses for blades, 13LA38.

Excavation Block (I) Strata	A			B			C			Total
	I	II	III	I	II	III	I	II	III	
Initial Biface	1	2	---	---	1	2	2	2	2	13
Primary Biface	1	1	---	2	6	8	7	7	11	43
Secondary Biface	6	1	---	1	2	3	7	8	7	35
Winged Drill	1	---	---	---	---	1	1	---	2	5
Simple Drill	3	1	---	---	1	---	2	---	---	7
Drill Fragment	3	1	---	---	---	7	3	1	8	21
Wide-Bit Drill	---	---	---	---	1	1	3	5	3	13
Primary Uniface	---	1	---	---	1	1	3	---	1	7
Secondary Uniface	---	---	---	1	---	2	---	---	1	4
Unidentifiable	---	---	---	---	---	5	---	---	4	9
<b>TOTAL</b>	<b>15</b>	<b>7</b>	<b>---</b>	<b>4</b>	<b>12</b>	<b>30</b>	<b>28</b>	<b>24</b>	<b>37</b>	<b>157</b>
Rectangular	---	2	---	2	1	---	---	4	1	10
Triangular	6	---	---	1	3	---	6	1	7	24
Pointed Ovate	1	1	---	---	1	3	1	1	---	7
Blunt Ovate	4	3	---	---	3	5	4	12	8	39
Lanceolate	---	---	---	---	---	1	---	---	2	3
Discoidal	---	---	---	---	---	---	1	1	2	4
<b>TOTAL</b>										<b>87</b>
Whole	3	3	---	---	4	8	6	10	11	45
Longitudinal Fragment	3	1	---	1	---	1	3	4	3	15
Distal Fragment	7	---	---	3	3	11	2	2	13	41
Proximal Fragment	2	---	---	---	1	---	3	2	6	14
Medial Fragment	---	3	---	---	1	5	7	3	---	19
Corner Fragment	---	---	---	---	3	---	2	1	---	6
Unidentifiable	---	---	---	---	---	5	5	2	4	16
<b>TOTAL</b>	<b>15</b>	<b>7</b>	<b>---</b>	<b>4</b>	<b>12</b>	<b>30</b>	<b>28</b>	<b>24</b>	<b>37</b>	<b>157</b>
Transverse Break	10	4	---	4	4	17	17	9	36	91
Diagonal Break	1	2	---	---	1	5	6	1	4	20
Oblique Break	2	3	---	---	1	6	6	2	6	26
Heat Treated	8	3	---	---	2	5	6	2	5	31
Burlington Chert	10	5	---	4	11	30	28	12	36	143
Warsaw Chert	5	2	---	---	1	---	---	5	1	14

Table 4.23: Chipped stone tool attributes, not including projectile points or retouched flakes, Stratum I, 13LA38.



Excavation Block	A			B			C			Total
	I	II	III	I	II	III	I	II	III	
Stratum	1	II	III	1	II	III	1	II	III	
Side notched	2	---	---	1	6	8	6	2	15	40
Oblique side notches	---	---	---	1	---	---	---	---	---	1
Corner notched	1	1	---	---	2	---	1	3	3	11
Parallel stemmed	---	---	---	---	---	---	---	---	2	2
Expanding stemmed	---	---	---	---	1	---	---	1	1	3
Contracting stemmed	---	---	---	---	---	---	1	---	---	1
Triangular	---	---	---	---	---	---	4	---	---	4
Unidentifiable	1	1	---	1	12	9	3	1	9	37
TOTAL	4	2	---	3	21	17	15	7	30	99
Straight base	2	1	---	---	1	2	2	1	9	18
Concave base	---	---	---	1	---	4	2	---	4	11
Convex base	1	1	---	1	5	---	6	4	1	21
Slightly concave	---	---	---	---	---	2	---	---	2	4
Triangular blade	4	1	---	2	8	6	13	4	14	52
Ovate blade	---	---	---	---	1	8	---	---	1	10
Excavate blade	---	---	---	---	---	---	---	---	---	0
Incurvate blade	---	---	---	---	2	---	---	1	---	3
Parallel ovate blade	---	---	---	---	---	---	---	---	1	1
Biconvex X-section	1	2	---	1	9	15	5	4	13	50
Bitriangular X-sec	---	---	---	---	1	2	2	1	---	6
Biplano X-section	1	---	---	---	3	1	3	1	6	15
Plano-convex X-sec	2	---	---	2	3	---	4	1	3	15
Convex-triangular	---	---	---	---	---	---	---	---	1	1
Heat treated	---	---	---	---	11	7	6	---	12	36
Basal fragment	---	---	---	---	---	1	2	---	5	8
Whole	3	---	---	2	5	5	8	5	9	37
Blade fragment	---	1	---	1	3	2	1	3	1	12
Distal end	1	---	---	---	7	7	2	---	6	23
Proximal end	---	2	---	---	3	4	2	1	8	20
Oblique break	4	---	---	---	---	---	3	---	6	13
Transverse break	---	3	---	---	14	10	6	2	13	48
Diagonal break	1	---	---	---	---	---	1	---	3	5

Table 4.24: Projectile point characteristics, 13LA38.

Excavation Block	A			B			C			Total
	I	II	III	I	II	III	I	II	III	
Stratum	1	---	---	---	1	---	5	---	---	7
Unknown type	1	---	---	---	1	---	5	---	---	7
Ansell constricted	1	---	---	---	---	---	---	2	---	3
Apple Blossom stemmed	---	---	---	---	---	1	---	---	---	1
"Besant-like"	---	---	---	---	1	---	---	---	---	1
Cedar Valley	---	---	---	---	---	---	---	2	---	2
Etlev	---	---	---	---	---	---	---	---	1	1
Gibson	---	---	---	---	3	---	---	---	---	3
Godar/Raddatz	---	---	---	---	2	2	---	---	5	9
Helton	---	---	---	---	---	---	---	---	1	1
Koster	---	---	---	---	---	---	---	---	2	2
Madison	---	---	---	---	---	---	2	---	---	2
Mankar corner notched	2	1	---	---	---	---	---	---	---	3
Mankar stemmed	---	---	---	---	1	---	---	1	---	2
Marshall barbed	---	---	---	---	---	---	1	---	---	1
Matanzas deep notch	---	---	---	---	---	1	---	---	3	4
Matanzas flared stem	---	---	---	---	---	---	---	---	2	2
Matanzas faint notch	---	---	---	---	---	---	---	---	2	2
Mills	---	---	---	1	---	---	---	---	---	1
Osceola	---	---	---	---	---	6	---	---	3	9
Reed	0	---	---	3	---	---	1	---	---	4
Snyder corner notched	---	1	---	---	---	---	---	---	---	1
Table Rock Pointed Stem	---	---	---	---	---	---	1	---	---	1
Burlington chert	2	1	---	2	6	19	13	3	28	74
Warsaw Tabular	2	2	---	---	10	---	1	2	---	17
Moline chert	---	---	---	1	---	---	2	---	---	3
Knife River	---	---	---	---	---	---	---	1	---	1
Keokuk chert	---	---	---	---	---	---	---	1	---	1
Gray/black/blue/white	---	---	---	---	3	---	---	---	---	3

Table 4.25: Projectile point attributes and chert types, 13LA38.

Stratum I: N=22	Total	Mean	SD	Max.	Min.
Length	13	3.0	1.3	5.0	2.0
Width	18	1.8	.8	3.8	1.2
Thickness	22	.5	.2	.8	.2
Notch width	12	.6	.2	1.2	.4
Notch depth	13	.3	.2	.8	.1
Edge angle	22	27	3	34	22

Stratum II: N=29	Total	Mean	SD	Max.	Min.
Length	11	4.6	1.9	9.5	2.5
Width	19	2.7	.8	4.9	1.7
Thickness	29	.7	.2	1.1	.4
Notch width	16	.8	.2	1.2	.6
Notch depth	16	.4	.1	.6	.2
Edge angle	26	32	7	55	24

Stratum III: N=48	Total	Mean	SD	Max.	Min.
Length	14	5.0	1.2	7.2	3.6
Width	43	2.5	.5	4.1	1.7
Thickness	48	.9	.2	1.4	.6
Notch width	29	.8	.2	1.3	.4
Notch depth	29	.4	.1	.7	.2
Edge angle	42	32	3	50	28

Table 4.26: Dimensions of projectile points from Stratum I, 13LA38.

U  
ANALYSIS OF FIRE-CRACKED ROCK,  
GROUND STONE AND METAL

Rocks comprised the bulk of the Sand Run assemblage. There were rocks sized from cobbles to fine gravel throughout the site deposits. Since the 13LA38 deposit is positioned on the footslope of an upland composed of sand and gravel, stones grading from fine gravel to palm-sized pebbles were natural inclusions in the site sediments due to colluvial slopewash. Field sorting of the rock was done to avoid transporting unnecessary weight, yet fire-cracked rock had to be retained for analysis. Rock discarded in the field included unmodified pebbles up to 5cm and all fine-medium gravel, excepting hematite and modified chert. The majority of the discarded pebbles consisted of sandstone and conglomerate, cherts, quartzite, metamorphic and igneous types--all typical of glacial tills in southeast Iowa. What was retained and returned to the laboratory for analysis eventually weighed about 274kg (from 52 cubic meters of excavation).

Laboratory processing and analysis began with washing and preliminary sorting of gross categories: e.g. fire-cracked rock, pigment rocks, shaped tools, metal. Then, the writer sorted and weighed the whole cobbles and broken/fire-cracked rocks, at the same time inspecting each piece for evidence of use-wear. Fire-crack rocks included specimens that were split or spalled, discolored or crumbly as a result of exposure to heat. Rocks were sorted into seven categories for weighing: coarse "igneous" (i.e. where the crystalline structure was visible in igneous and metamorphic rocks), fine igneous (i.e. where crystals were too small to see with the naked eye), quartzite, sedimentary (e.g. sandstone, limestone, conglomerate), limonite, unmodified hematite, broken chert (i.e. crazed, spalled, split by heat only). Rocks lacking evidence of use-wear were discarded. Utilized rocks, hematite, limonite, metal and ground stone tools were catalogued and retained for permanent curation.

Unmodified Cobbles & Fire-Cracked Rocks

These remains are tabulated by excavation block and stratum in Tables 5.1, 5.2 and 5.3. The overall impression from this data is that fire-cracked rock is ubiquitous in all Woodland and Archaic components. Some variations in rock density are evident between components in different blocks (e.g. compare Strata I and III in Block A with I and III in Block C), but this is due in part to the incidental positioning of blocks over cultural middens. The ubiquity of rocks indicates that prehistoric people needed devices to retain heat in domestic hearths. This is a

general pattern in Woodland and Archaic sites across the Prairie Peninsula in Iowa.

The rocks from Sand Run do show a distribution pattern between the three strata. Stratum I, the Late Woodland period, has a rock density of 3112gm per cubic meter. Stratum II, the Middle Woodland period, has a density of 2114gm per cubic meter, while the Late Archaic Stratum III has a much higher density of 9419gm per cubic meter. While rock density probably has something to do with intensity and duration of activities, this is impossible to measure. For a rough comparison of rock density, we can look at the tabulations for Strata II and III in Blocks B and C (Tables 5.2, 5.3). Strata II and III in Block C were dark middens with many features, yet the density of rock in Stratum III is much higher. The same comparison and result can be seen between Block B Stratum II and Block C Stratum III, both being components with many features.

Another significant observation about the rocks is that whole cobbles are not common. They comprise about 10% of the weight of the entire assemblage (and whole stones have higher average weights than fragments). A small proportion of rock disintegration is due to post-occupation weathering, but the vast majority of broken and crumbled rock was excavated in fragments already scattered by the aboriginals. From this it is concluded that most rocks were used until they became too broken or crumbly to be functional. This would require several episodes of heating and battering, if we can judge the state of aboriginal rocks against the more intact condition of cobbles ringing modern campfires on shorelines today. Perhaps, it was the post-heating activities (e.g. hammering, moving, etc.) that caused aboriginal rocks to break.

The fire-cracked rock data also reveal a preponderance of coarse rock types (54-65%), with the "fine igneous" category comprising most of the rest of the rock (12-38%). This preference for coarse (igneous) rocks of all types was a pattern in the rock data from the central Des Moines valley (Benn 1985:149), and is a pattern other researchers have noticed as well (e.g. Stanley 1987). Igneous rocks are common in the glacial tills and are hard and dense enough to be applied in a variety of domestic activities.

#### Ground Stone & Metal Items

In this analysis the unmodified or broken rock has been separated from the rocks that exhibit intentional modification or use-wear. Human modifications in broken rocks were determined by comparing natural and worked facets so that weathering sheen and glacial striations could be excluded. The modified materials were segregated into "type" categories, an approach promoted by George Odell for rapid processing of use-wear evidence from the Smiling Dan site in Illinois. Odell's "type" is a combination of

stylistic, technical or functional criteria "...designed to isolate those attributes and objects judged to possess cultural significance." (1985:298) Fourteen types are tabulated below.

Table 5.4  
Metal and Ground Stone  
13LA38

type	Stratum		
	I	II	III
copper	awl (100%)	-	-
galena	-	1 (33%)	2 (67%)
hematite (color)	-	4 (15%)	23 (85%)
limonite (color)	-	1 (33%)	2 (67%)
hammerstones	4 (11%)	12 (32%)	22 (69%)
abraders	1 (20%)	-	4 (80%)
manos	5 (17%)	6 (21%)	18 (62%)
metates	-	2 (33%)	4 (67%)
paint pallets	-	-	2 (100%)
choppers	-	1 (50%)	1 (50%)
mullers	-	-	1 (100%)
grooved axes	-	-	8 (100%)
celts	1 (25%)	-	3 (75%)
bannerstones	-	-	2(1?) (100%)
net weight	-	1 (100%)	-
miscellaneous	-	-	1 (100%)

The distribution of items among the three strata shows a high concentration of ground stone tools and coloring minerals in the Late Archaic components. This pattern is paralleled in the fire-cracked rock remains. Noteworthy artifact patterns include all grooved axes, bannerstones, most celts and the majority of coloring minerals and galena from the Late Archaic components (Stratum III). The incidence of metals and coloring agents are noticeably low in the Middle Woodland components (Stratum II). The Late Woodland Stratum I yielded the only copper awl, a piece of galena and a celt. Other patterning breaks down within types, described below.

An unusual grouping in the Late Archaic assemblage is five limonite cobbles. These are tabular rocks with a 2-3mm thick rind of yellow cortex. Limonite cobbles and pebbles occur in the local glacial tills. Limonite was rubbed to produce yellow color, and two cobbles have pitting and rubbing typical of use as metates. Another limonite cobble was grooved. The cortical rind has formed over the flaking and wear on limonite since the occupation, making identification of artifact types difficult. During the fieldwork a local collector removed a tabular limonite cobble the size of a "welcome mat" from the river bank. No

use-wear was evident on this cobble, which was abandoned at the site before the significance of limonite was fully apparent.

Copper Awl (Figure 5.1a): A piece of thin copper sheet was tightly rolled to form an awl, 60mm long and 4mm thick. Both ends are sharply pointed.

Galena (Figure 5.1b): A 9gm cube came from Stratum I, and a 19gm cube and 50gm rounded pebble came from Stratum III. The pebble has an abraded facet.

Hematite Color (Figure 5.1c): All but one of the 27 hematite pieces is a pebble; the remaining piece is large (129gm) and heavily worked. The pebbles average 13gm. Eighty-five percent of the hematite is the metallic (specular) form, the rest being the soft, grainy form. Twenty pieces retain fine scratches and striations as a result of grinding to obtain red powder. Eight pieces are smoothed because of grinding, and nine are polished due to rubbing or because they have been stored in soft containers. The largest piece is flattened and completely smoothed, but a transverse break destroys any indication of other functions.

Limonite Color (Figure 5.2): One small pebble concretion from Stratum I is broken but retains a spot of heavy rubbing and striations from a sharp instrument (chert flake?). Two large, flat cobble concretions (455gm, 357gm) from Stratum III have broad faces with numerous, fine parallel striations from an abrader. One of these cobbles is broken, and its adz-shaped edge has been retouched unifacially (but not utilized).

Hammerstones (Figure 5.3): Rocks with patches of pitting and crushing were employed to hammer other materials. Hammers are made from granite (n=15), chert (7), diorite (4), rhyolite (3), quartzite (3), andesite (2), basalt (2) and sandstone (1). Most hammered patches occur on rounded edges (Figure 5.3b), but seven are found on flat faces of cobbles. Two of the latter from Stratum II consist of a single deep pit (Figure 5.3a,c), as if the cobbles were utilized as anvils to position an object (core?) in one spot. The average size of hammerstones varies by component: Stratum I 132gm (n=2), Stratum II 551gm (n=8), Stratum III 257gm (n=17). Four hammerstones were associated as a pile forming feature 21 Stratum IIIa: diorite 288gm, basalt 379gm, and two granite 263gm and 218gm.

Abraders (Figure 5.4a-c): These tools do not have a regular shape. Rather, pebbles and cobbles were employed as abraders because their granular structure fulfilled a functional need. An andesite cobble (585gm; also a grinder--see below) from Stratum I has three broad, irregular grooves on one facet (Figure 5.4a). The grooves are rough enough to be considered platform abraders used by flint knappers. Two sandstone pebbles (88gm, 26gm; Figure 5.4c) and one andesite fragment from Stratum III also have wide grooves that could be platform abraders or of use in working

bone or wood. A fourth sandstone abrader (120gm) from Stratum III has two smoothed, concave faces used to abrade wide objects (Figure 5.4b).

Manos (Figure 5.4d-h): These are the most common grinding tools. Manos are hand-sized cobbles (ave. weight 253gm; n=7) made from basalt (n=8), andesite (8), diorite (3), rhyolite (2), quartzite (2) and sandstone (1). Seventeen specimens have a single facet of wear, while six have two facets and one has three facets. Three-quarters of the sample have smooth wear (Figure 5.4e), and half the sample is marked by parallel striations (Figure 5.4d,f-h). Five have fine striations, and seven have medium-broad striations or grooves. Two are dulled, and four are pitted. Polish breaks down as bright (1), moderately bright (7) and dull (2), and one mano has red staining. The paucity of bright polish excludes the function of grinding plant materials with high cellulose contents. The manos with heavy striations were used on hard, coarse materials, while those with fine striations and smoothing were used on fine grained and/or soft materials. Grinding seeds and nuts, shredding fibers, pounding meat and fabricating other ground stone tools probably are the likely functions represented by this assemblage.

Metates (Figures 5.2, 5.6): Three metates are preserved only as small fragments, but three others are intact. The largest from feature 9 Stratum II is a tabular basalt cobble weighing 1500gm (Figure 5.6). Both surfaces are smoothed and relatively flat with numerous small pits broken into the smoothing. One rounded edge is extensively pitted. The surface has a dull polish. Pitting results from breaking hard materials (e.g. nuts) on the metate, while smoothing results from grinding with a mano. Thus, this was a multi-purpose grinder and anvil. It was associated with three granite hammerstones and an unmodified granite cobble in pit feature 9. Two limonite cobbles from Stratum II also have extensive pitting and dulling (grinding) on both flat faces (Figure 5.2). Metate fragments include a sandstone cobble from Stratum II and two quartzite cobbles from Stratum III. These are 13mm, 15mm and 13mm thick respectively. All three have opposite faces smoothed and somewhat depressed by grinding. Bright polish is present on one of the quartzite metates. Wear on the three metates indicates only grinding functions and coarse vegetable foods in the case of the polished specimen.

Paint Pallets (Figure 5.1d): Pieces of tabular basalt (110gm) and slate (200gm) from Stratum III have patches of smoothing on flat faces. One has dull polish and the other moderately bright polish. The small size and fine nature of the smoothing indicate these stones were used to grind and mix non-gritty materials, like coloring powder and grease.

Chopper (Figure 5.5c,d): Two choppers were recovered from Stratum II and III. The rhyolite specimen (540gm) was naturally wedge-shaped, and its pointed end has use-wear of flaking, battering and rounding. The basalt spall retains unifacial



flaking on a convex edge, which also is rounded, battered and has dull polish. A third (cutting?) tool from Stratum I consists of a basalt spall with steep, unifacial flaking on one concave edge. All three tools appear to have been used in heavy cutting and chopping of meats and soft vegetable foods.

Mullers (Figure 5.2, 5.5a,b): These cobbles from Stratum III tend to be heavier with wider working edges than choppers. One limonite cobble was grooved but now is broken (other incipient grooving indicates this object may have been used as a net weight). An andesite tool weighs 837gm, and a basalt tool weighs 173gm. All have wide edges with extensive battering, spalling and flaking. Some rounding and smoothing also is present, and the andesite specimen has dull polish. Mullers were used on a variety of hard and soft materials but not on plant fibers with high cellulose contents.

Grooved Axes (Figure 5.6d-h): A total of eight pieces of different axes was recovered from Stratum III. All comprise a small portion of the poll and groove sections. Two are made from granite, three from basalt, two from diorite and one from rhyolite. Two were three-quarter grooved axes, and two were squared or rectangular in cross-section. Half are finished with partial smoothing over pecking, while the others are completely smoothed (two are burnished). At least one partially smoothed surface may represent an unfinished ax. Overall sizes appear to have been small to moderately large. Two are measureable: poll length 62mm and 35mm, groove width 44mm and 37mm, groove depth 16mm and 7mm. No working surfaces are present for analysis.

Celts (Figure 5.6b): A shank spall made from diorite was found in Stratum I. This item retains bright polish from working wood. A whole diorite celt from Stratum III weighs 150gm and has dimensions of 88mm length, 46mm width and 22.5mm thickness. Its surface is partially smoothed over the pecking. The bit retains many wear flakes and some crushing. The bit and cheeks are asymmetrically ground (adz-like), and the working surface has extensive bright polish. Two other celts came from Stratum III: a granite poll fragment and a basalt shank fragment (49mm thick). The basalt specimen has moderately bright polish.

Bannerstones (Figure 5.6c): The corner of a "bow-tie" bannerstone was recovered from Stratum III. This diorite piece has bold black and white crystalline structure similar to bannerstones in the possession of local collectors in Louisa County and from the Osceola site (Overstreet 1984b:Plate XIc). The fragment's surface is very smooth and retains very fine parallel striations from the abrading process. It has a dull burnished surface. Another edge fragment from Stratum III is made from black diorite. This may also be a celt bit, but no use-wear is evident. The object has smoothed, burnished lenticular surfaces that converge at a rounded edge. The original striations from the smoothing process are evident.

Net weight (Figure 5.6a): This is a 302gm basalt object from posthole feature 17 in Stratum II. It appears to be a celt poll with the bit end broken. The weight has been grooved longitudinally by pecking completely around the circumference. Collectors in Louisa County have possession of several grooved but otherwise unmodified stones from sites that also yield grooved axes. Two grooved stones were said to have come from a site in the uplands.

Miscellaneous: A basalt cobble fragment has a broken straight edge with wear-flaking, crushing and rounding in one spot. Bright polish is present adjacent to the battered patch. The function of this object is uncertain, but its shape suggests use as a pounder or anvil, depending on orientation.

### Discussion

The variety of tools described above indicates that many different domestic activities were pursued at Sand Run. No specific seasons of occupation can be inferred from the tools, since the tool functions could cover processing of meat, vegetable products and nuts as well as the fabrication of a wide range of materials. However, the processing of grasses and other cellulite plants for functions like matting is not particularly evident. Occupations when the tools were used are inferred to have been intensive and long-term, since many tools evidence multiple functions and most have been recycled as heating rocks. The varied assemblage and damaged condition of the cobble tools from Sand Run contrasts sharply with many upland sites frequented by collectors in Louisa County. Upland sites often yield a narrower range of tool types and a noticeably larger proportion of whole tools (e.g. celts, grooved axes, bannerstones).

The tool assemblages in the three strata at Sand Run are different enough to require some interpretation. Differences probably are not related to sample size because of the position of excavation blocks within the site. Fire-cracked rock, ceramic and chipped stone are numerous enough in Strata I and II to indicate intensive occupations like Stratum III. On the other hand, the likelihood of recovering low density items like exotic metal probably is small in average-sized excavations like Sand Run, so we cannot take the relative percentages of artifact types in Table 5.4 too literally.

The Late Woodland age Stratum I is poor in ground stone implements, with only small hammerstones, a few grinding tools and a celt. Exotic metals also are present. Likewise, the Middle woodland Stratum II is surprisingly devoid of many types of ground stone. Hammerstones in Stratum II are large and probably were not used for knapping chert. The platform abrader and two pitted hammer/anvil stones could have been employed in knapping chert. Color sources like hematite are present to indicate participation in an interaction sphere.

All tool types except pallets and net weights are present in Late Archaic Stratum III to indicate intensive and long-term occupations. Galena probably from the Quad-State region and hematite (from the glacial tills?) are represented to demonstrate a network of commodity exchange. Hammerstones from Stratum III are small enough to be employed as knapping instruments (see "Chipped Stone" for a discussion of hard-hammer percussion). Aside from the tool functions, the presence of many examples of shaped tools (e.g. celts, axes, bannerstones) and numerous informal tools (e.g. grinders, abraders, hammers, etc.) suggests that Late Archaic peoples spent a large portion of their labor on the manufacture and use of ground stone tools. This amount of labor expenditure is not evident in the Woodland assemblages.



Figure 5.1: Items from the 13LA38 excavation blocks; a) copper awl; b) three lumps of galena; c) five pieces of specular hematite (upper left is scratched and smoothed; upper right is polished; lower middle is ground and faceted; lower corners are raw pebble forms); d) slate paint pallet with edge flaking.

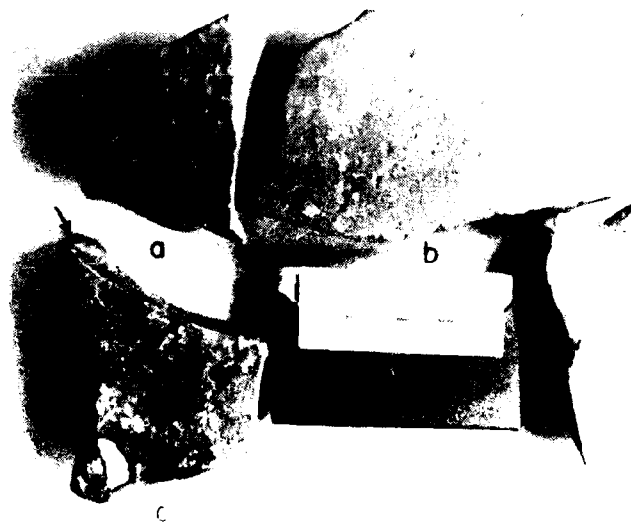

Figure 5.2: Limonite cobbles from the 13LA38 excavations; a) metate with coarse abrading; b) smoothed metate with pitting; c) cobble with "adz" retouch; d) grooved (broken) muller.

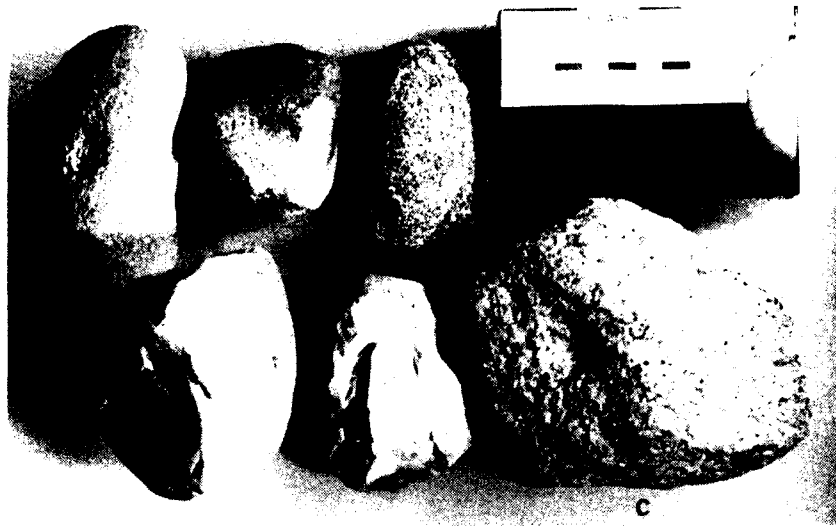

Figure 5.3: Hammerstones from the 13LA38 excavation; a,c) pitted;  
 b) four hammers with battered edges (above igneous, below chert).



Figure 5.4: Grinding stones from the 13LA38 excavations; a) grooved  
 and striated abrader; b) cupped sandstone abrader; c) two grooved  
 sandstone pebbles; d) striations on a faceted mano; e) smoothed and  
 faceted mano; f) three faceted and striated manos.

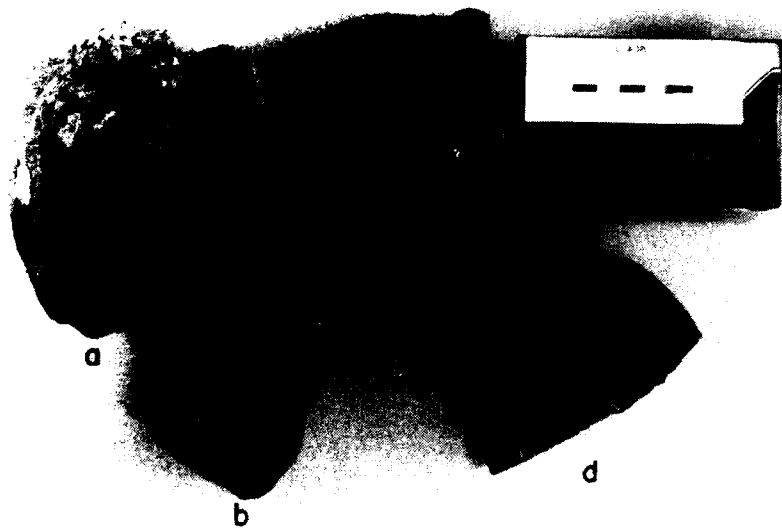

Figure 5.5: Tools from the 13LA38 excavations: a,b) mullers made on broken cobbles; c) chopper (working edge above); d) cutter/chopper on basalt cobble spall.

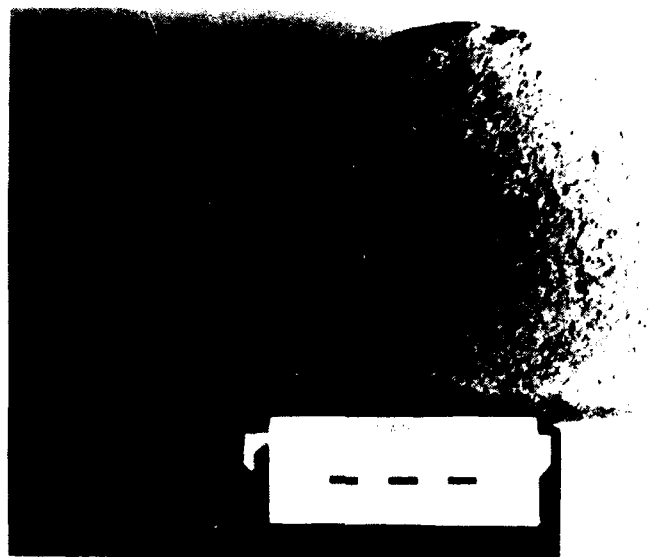

Figure 5.6: (top) Large metate on igneous cobble with heavily pitted and smoothed surface and edges; (below) a) grooved net weight made from a broken celt/ax; b) celt (bit to left); c) bannerstone fragment; d-h) grooved ax poll fragments (h is a squared poll).

Table 5.1  
13LA38 Block A  
Cobbles & Fire-Cracked Rocks

FIRE - CRACKED ROCK										
Stratum lev.	Whole Cobbles & Smoothed Pebbles	coarse igneous	fine igneous	quartzite	sedimentary	limonite	hematite	chert	Misc. Items	Excava. Area m <sup>3</sup>
I	1	-	141	199	--	--	--	8	Shotgun shell	
	2	granite-100	1399	421	114	46	6	28	26	
	3	f. igneous-419 pebble - 14	2274	791	90	223	16	--	51	
	4	-	2866	2346	--	--	--	211		
	fea 3	granite-1163 f. igneous-980	751	202	72	--	--	3		
		% all rock	58	36	2	2	0.1	0.2	2	total 14,949gm 5339 gm/m <sup>3</sup>
II	5	chert - 56	1095	463	79	--	--	27		
	6	-	970	833	--	--	37	8	13	
	7	-	37	71	--	--	--	--		
	fea 1	-	194	29	--	40	12	--	41	
	fea 2	-	46	70	--	--	--	--	--	
	fea 4	-	112	85	--	16	--	--	--	
	fea 5	granite - 186	1094	180	45	82	--	--	70	
	fea 7	-	95	133	--	--	--	--	--	
	fea 8	-	291	196	7	--	--	--	3	
	fea 9	-	82	87	--	109	79	--	9	
		% all rock	61	31	2	4	1	--	3	total 6897gm 3284 gm/m <sup>3</sup>
III	9	chert - 603 quartz - 76	--	--	--	--	--	--		
	10	granite - 137	126	130	28	--	27	--	46	
	11	f. igneous	244	--	--	--	--	--	43	
	12	-	456	57	--	--	--	--	--	
	13	-	260	--	--	--	--	--	--	
	15	-	53	--	--	--	--	--	--	
		% all rock	57	12	1	--	1	--	29	total 2375gm 3958 gm/m <sup>3</sup>



fea										
fea										
fea										
fea 3										
fea 4										
fea 6										
fea 7		518	328	--	--	--	--	38		
fea 8	chert 604	--	--	--	--	--	--	--		
fea 9	granite 380	982	12	--	--	--	--	--		
fea 10		270	--	35	--	--	--	20		
fea 11		321	--	15	122	--	--	--		
fea 13		298	--	--	--	--	--	--		
fea 16		113	--	--	--	--	--	--		
fea 31		333	20	16	5	--	--	--		
% of all rock		63	24	5	3	0.2	--	5	total 15837 1842 gm/m <sup>3</sup>	8.6

IIIa	11	chert 159	1876	146	--	121	22	--	--	
	12	chert 79	2872	726	76	103	--	--	133	
	13	granite 58 sedimentary 137	4926	1464	489	277	--	19	23	
	14	hematite 47 red ochre pebble	5625	2175	201	460	--	--	97	
fea	18		104	152	--	224	--	--	--	
fea	19		544							
fea	20/2		1454	265	4	--	--	--		
fea	21	schist 400 granite 482	282							
fea	33		78	36	--	29	--	--	--	
fea	34		226	46	27	--	--	--	14	
IIIb	15	basalt 108 granite 2024 sandstone 64 chert 116 sedimentary 845	6139	2914	230	547	--	--	148	
	16	chert 60 quartzite 59 hematite 14	3954	1889	280	263	--	--	49	
	17	sandstone 68	2861	871	221	24	--	--	61	
fea	23		251	--	56	37	--	--	--	
fea	24		373	184	10	106	--	14	--	
fea	25		255	--	--	--	--	--	--	
fea	35		610	247	--	--	--	--	--	
fea	36		6	--	--	--	--	--	--	
IIIc	17		973	138	152	--	--	--	--	
	18	granite 540	2458	1695	453	200	--	--	317	
	19		1343	394	38	131	--	--	22	
	20		112	45	20	28	--	--	--	
	21		107	--	--	--	--	--	--	
fea	26	granite 503	1716	655	--	213	--	--	--	
fea	27	quartzite 988	962	183	--	52	--	--	--	
fea	28		517	264	207	45	--	--	--	
fea	29		360	65	--	14	--	--	--	
fea	30		134	66	--	15	--	--	--	
fea	37		26	125	--	--	--	--	110	
fea	38		56	61	--	--	--	--	--	
% of all rock		65	22	5	6	0.0	0.1	28	total 69144 5668 gm/m <sup>3</sup>	12.2

Table 5.3  
13LA38 Block C & Test Unit 5  
Cobbles & Fire-Cracked Rocks

FIRE - CRACKED ROCK										
Stratum	lev.	Whole Cobbles & Smoothed Pebbles (gm)	coarse igneous	fine igneous	quartzite	sedimentary	limonite	hematite	chert	Extrava. Vol. m <sup>3</sup>
I	1	quartzite 135	245	142	15	--	--	--	52	
	2	granite 900 quartzite 55	267	418	113	58	91	--	39	
	3	granite 116	2464	1699	206	--	--	--	64	
	4	granite 1491	3499	2596	675	300	--	--	134	
	5	quartzite 136 f. igneous 111 sandstone 33 basalt 98 granite 246	4066	3093	367	117	67	--	265	
		% of all rock	54	33	7	2	0.6	--	2	total 24379gm 3483 gm/m <sup>3</sup>
II	6	quartz 247 sedimentary 68 f. igneous 81 chert 98	2682	1802	276	77	--	--	221	
	7	chert 280 granite 177	3507	1581	122	119	--	--	259	
	8	basalt 770 granite 39 sandstone 228	4798	1545	56	84	--	--	128	
	9	granite 202 sedimentary 75 basalt pebble 66	4694	1266	138	55	--	--	57	
		% of all rock	64	27	2	3	--	--	4	total 25717gm 4592gm/m <sup>3</sup>
III	10	quartzite 360	4054	2315	391	23	--	--	167	
	11	granite 307	6217	4478	598	271	--	--	95	
	12	granite 508 quartz pebble 15 basalt 452 chert 89 quartzite 448	12300	8465	1778	294	--	--	355	
	13	f. igneous	9865	6198	691	895	98	--	178	
	14	f. igneous chert 66	13615	8651	2038	1538	8	--	457	
	15	granite pebbles 141 granite 869 quartzite 244 basalt 115	8953	3846	617	136	--	12	66	
	16	granite 124 sedimentary 87	61	274	68	19	--	--	342	
	fea 2		168	189	--	101	--	--	--	
	fea 4		--	25	--	--	--	--	--	
	fea 7	granite 508 sedimentary 340	1822	1035	164	--	--	--	--	
	fea 8		1260	655	132	77	--	--	260	
	fea 9	granite 1200	267	--	--	--	--	--	--	
	fea 10	granite 960	1720	352	--	--	--	--	--	
	fea 11		36	--	--	--	--	--	--	
	fea 12		324	379	--	31	--	--	10	
	fea 13		614	85	--	--	--	--	--	
	fea 14		1824	1190	653	131	--	--	40	
	fea 15		1336	396	92	--	--	--	9	
	fea 16		372	9	--	--	--	--	--	
		% of all rock	56	32	7	3	0	0	2	total 123162gm 15628 gm/m <sup>3</sup>

VI  
ARCHAEOBOTANY

by  
Neal H. Lopinot  
Research Associate, Washington University

The analysis of flotation-recovered plant remains from Sand Run West provides a rather unique opportunity to examine Late Archaic and Middle Woodland human-plant relations in southeastern Iowa. In particular, the archaeobotanical remains from the Late Archaic component at the Sand Run West site include a rather interesting and diverse spectrum of seeds, as well as other plant materials. Virtually nothing is known about human-plant relations in southeastern Iowa during the Late Archaic period (cf. Lensink, ed. 1986), nor for adjacent portions of Illinois and Missouri. In addition, the record of Middle Woodland relations is almost equally void for this area. Although the analysis of systematically recovered plant remains from other sites in the region will eventually aid in refining our knowledge about changing subsistence patterns during the Late Archaic-Middle Woodland sequence, the following data provide a rather good basis for beginning to model plant resource procurement strategies and changes during this 3000 year span of prehistory.

Analysis Methods

A total of 20 flotation samples were analyzed. These represent 168.5 liters of feature fills (Table 6.1). The sampled Woodland features include: Feature 1 from Area C, Stratum I; two (Features 8 and 9) from Area A, Stratum II; five (Features 3, 6, 7, 9, and 31) from Area B, Stratum II; and Feature 5b from Area C, Stratum II. The single feature from Stratum I dates to the Late Woodland period, whereas the eight features from Stratum II date to Middle Woodland period. The sampled Late Archaic features include: three (features 18, 33, and 34) from Area B, Stratum IIIa; two (Features 23 and 25) from Area B, Stratum IIIb; three (Features 27, 28, and 38) from Area B, Stratum IIIc; and three (Features 7-1, 9, and 17) from Area C, Stratum III. Samples from these features were nonrandomly selected for analysis based on their relatively great abundance of plant remains. Flotation and some preliminary sorting of the samples were undertaken at the Center for Archaeological Research (see addendum) prior to their receipt by the author.

The analysis of flotation-recovered plant remains first involved pouring the light fractions into two nested sieves (U.S.A. Standard Testing Sieves Nos. 10 and 35) with a pan on the bottom. This sorted the remains into three size fractions:  $>2.0$

mm,  $<2.0$  mm but  $\geq 0.5$  mm, and  $<0.5$  mm. All materials captured in the larger sieve mesh were entirely sorted. The two smaller fractions were scanned for seeds, both carbonized and uncarbonized, and for other plant materials not represented in the larger fraction. The presence of nonseed materials only in the 0.5 mm size fractions was noted. This approach permits calculations of more reliable ubiquity indices, theoretically reflecting the frequency of usage better than counts and weights for size-biased remains. The smallest fraction, that which passed through the 0.5 mm sieve, also was scanned for very small seeds (e.g., tobacco, purslane, etc.).

Materials equal to or greater than 2.0 mm in diameter were sorted into general debris classes, each placed in individual plastic (7 dram) or glass (.5 dram) vials. They were then rechecked, counted and weighed on a Fisher Model 7204 electronic toploading balance, accurate to  $+0.01$  gm. If a particular debris class did not register one-hundredth of a gram, a "t" (trace amount) was given for the weight in that category. Weights also were obtained for all materials smaller than 2.0 mm in diameter, referred to here as the "residual" fraction. The residual fraction includes both the 2.0-0.5 mm and the 0.5-0.0 mm size fractions. The total weights of the size-sorted fractions were added to the weights for the residual fractions for the purpose of calculating approximate densities of archaeobotanical remains (gm/10 liters) per sample. Unfortunately, such density estimates must be considered less than ideal given the varying amounts of modern plantpart contaminants. Many of the flotation samples from Sand Run West contained abundant uncarbonized plant tissues. Regardless, there exists a general correlation between the quantities of sorted carbonized remains and the weights of residual fractions.

More detailed analyses were conducted for wood charcoal, Carua nutshell and seeds. Wood charcoal subsamples of 20 specimens per provenience were selected for taxonomic identifications. A similar subsampling strategy was invoked with respect to Carua nutshell fragments. Whereas each of the 20 samples contained more than 20 wood charcoal fragments, eleven samples contained less than 20 identifiable Carua nutshell fragments. When samples contained less than 20 specimens, then an attempt was made to analyze all fragments. If more than 20 fragments were present, analyzed specimens were selected from numbered cells within a gridded tray using a random numbers table. Identifications of wood charcoal fragments were conducted with the aid of the author's comparative carbonized wood collection and various manuals (e.g., Panshin and De Zeeuw 1980). The analysis of Carua nutshell fragments involved measurements of shell lobe thicknesses (see Lopinot 1984a). If a specimen was sufficiently large, the probable represented species was noted based on an elevation of external sculpturing and projected whole nut size.

Both uncarbonized and carbonized seeds were picked from the samples and, regardless of size, placed in a single vial per sample. The presented numbers of seeds represent SNEs (Seed Number Estimates) based on both whole seeds and fragments of seeds. The SNE for any given taxon was based on counts of particular morphological features (e.g., the hilum, cotyledon halves, etc.), weights of fragments relative to represented whole seeds, or both. Whereas uncarbonized seeds were collected and identified, it is assumed that uncarbonized plant materials represent recent contaminants (Lopinot and Brussell 1982). However, the types and quantities of uncarbonized seeds provide comparative bases for inferring possible prehistorically carbonized, fortuitous inclusions. Taxonomic identifications again were conducted with the aid of the author's comparative collections and various manuals or published articles (e.g., Martin and Barkley 1961; Montgomery 1977).

### Results

A total of 4040 non-seed fragments weighing 40.50 gm was sorted from the 20 samples. In addition, 149.39 gm of residual debris were scanned for seeds and other debris classes lacking from the sorted fraction. Besides seeds, 13 major classes of debris were represented. The counts and weights for these are given in Appendix E. These classes consisted of wood charcoal, bark, twig fragments, fungal tissues, grass/herb stem fragments, five different types of nutshell, two types of underground stems and squash rind. Of the total, 106 fragments weighing .85 gm could not be identified. The average density of plant remains is 11.27 gm/10 liters of fill.

Wood charcoal, hickory (Carva spp.) nutshell, Juglandaceae (indeterminate hickory or walnut) shell and acorn shell were represented in all 20 samples. Other material classes with high ubiquity indices include bark (90% or 18 samples), walnut (Juglans spp.) shell (60% or 12 samples) and tuber/rhizome fragments (55% or 11 samples). As can be expected, acorn shell was not identified in seven 2.0 mm fractions, nor did it occur abundantly in any of the other 13 samples. Yet acorn shell was present in all 20 residual fractions, sometimes occurring quite abundantly. These observations point out the importance of noting the presence of various classes of debris in residual fractions that are often lacking in larger sorted fractions. By so doing, the biasing effects of differential preservation are offset. Notably, the presence of squash rind, grass/herb stem fragments, and fungal tissues also were entirely or largely restricted to residual fractions (see Appendix E).

A summary of the counts and weights per debris class is given in Table 6.2 for Stratum II features (n=8) and Stratum III features (n=11). The data in Table 6.2 clearly indicate that plant remains in the 2.0 mm fractions were significantly more dense in Stratum III features than in Stratum II features. By

count, the density of plant remains was 143.7 for Stratum II and 306.1 for Stratum III, or more than twice as dense. By count, the density of plant remains was 1.32 for Stratum II and 3.12 for Stratum III. The density of nutshell, in particular, was much greater for Stratum III than for Stratum II. By count, the nutshell density is 25.7 for Stratum II and 118.4 for Stratum III. By weight, the nutshell density is .28 for Stratum II and 1.49 for Stratum III. Only the relative quantities of wood charcoal are less for Stratum III than for Stratum II.

It is also notable that plant remains generally were larger and in better condition in Stratum III features than in Stratum II features. This is illustrated by the fact that: (1) the average weight per specimen is 9.1 mg for Stratum II and 10.1 mg for Stratum III; and (2) the weight ratio of larger, sorted plant remains: residual material is .195 for Stratum II and .322 for Stratum III. These data indicate that larger plant remains are proportionately more common in Stratum III than in Stratum II. Interestingly, several of the Stratum III samples also contained semi-carbonized plant remains, including a few nutshell and wood fragments, numerous bark fragments, and occasional seeds. This may be an indication of better preservation conditions fostered by favorable geochemical conditions and/or fairly rapid burial, and concomitant decreases in surface exposure to weathering and trampling.

#### Wood Charcoal

Wood charcoal occurs in all 20 samples, numbering 1183 fragments and weighing 9.60 gm. Wood charcoal is numerically more abundant than any other type of charred material in the Stratum II feature samples, a typical characteristic of many Woodland and Mississippian archaeobotanical assemblages from sites to the south. In contrast, wood charcoal occurs as the most abundant material remain in only two of the 11 samples from the Archaic Stratum III features. The dominant materials in the remaining nine samples are nutshell (six samples) and bark (three samples). Again, the dominance of nutshell in particular appears to be common for Middle and Late Archaic archaeobotanical assemblages from sites to the south (e.g., N. Asch et al. 1972; D. Asch et al. 1979; King 1982; Johannessen 1984).

A total of 400 fragments was randomly sampled for taxonomic identification. Of this total, 311 or 77.8% were identified to at least the family level. The remainder were identified as knotwood fragments, or simply as ring porous, semi-ring porous, diffuse porous and indeterminate. By chance alone equal numbers of specimens (146) were identified for the Stratum II and Stratum III features. Summary data are presented in Table 6.3, whereas the sample-by-sample data are presented in Appendix E.

The spectra and proportions of identified wood taxa are basically identical for the Stratum II and Stratum III

assemblages. Oak and hickory wood charcoal fragments dominate both assemblages, comprising 59.7% or 87 of the identifiable fragments from Stratum II features and 61.8% or 90 of the identifiable fragments from Stratum III features. Those taxa which are moderately frequent in features from both strata include ash (Fraxinus spp.), hackberry/elm (Celtis/Ulmus spp.) or Ulmaceae, and cottonwood/willow (Populus/Salix spp.).

Differences between the two series of samples are slight, and such variability may be due to sampling error. One difference consists of slightly greater numbers of hickory/pecan charcoal fragments in Stratum III, offset by slightly greater numbers of oak charcoal fragments in Stratum II. However, it also may be noted that Carua wood charcoal occurs in 87.5% (7) of the Stratum II samples and in only 63.6% (7) of the Stratum III samples. Another difference relates to ubiquity indices for various taxa. For example, maple (Acer spp.) charcoal fragments occur in six of the eight (75%) Stratum II samples, in contrast to only three of the 11 (27%) Stratum III samples. In addition, hackberry/elm and ash (Fraxinus spp.) charcoal fragments have greater ubiquity indices for Stratum II samples (87.5% and 75.0%, respectively), than for Stratum III samples (54.5% and 45.4% respectively).

The quantities and types of wood taxa for features from both strata suggest very generalized wood exploitation from similar types of available habitats. A wide array of habitats are represented, including shorelines, floodplain forests, mesic ravines/slopes, and perhaps blufftops. Certainly, the Sand Run West site is well situated to take advantage of all of these types of forested habitats. The "firewood indifference hypothesis" presented by D. Asch and N. Asch (1976) may apply to both the Late Archaic and Early-Middle Woodland exploitation strategies. That is, least effort dictated the quantities and varieties of selected fuel woods. Thus, the nearest available fuel materials, principally in the form of deadwood, would be expected to have provided the bulk of the fuel wood supplies. The quantitative abundance and spectra of wood charcoal, in turn, should generally reflect the forest composition in the vicinity of the site.

#### Nutshell

Nutshell occurs in each of the 20 samples. A total of 1346 nutshell fragments weighing 16.48 gm was sorted from the 2.0 mm fractions. Four different genera are represented. These consist of hickory/pecan (Carua spp.), walnut (Juglans spp.), oak acorn (Quercus spp.) and hazelnut (Corylus americana). Nutshell fragments that were identified as Juglandaceae included indeterminate fragments of either hickory/pecan or walnut. These typically include septae fragments and fragments which were either too small or too eroded to differentiate smooth versus rugose pericarps.

Carua spp. nutshell represents 82.0% by count and 77.5% by weight of the nutshell fragments identified to the genus level (i.e., excludes Juglandaceae nutshell fragments) for Stratum II and Stratum III features combined. Undoubtedly, a vast majority of the nutshell identified only as Juglandaceae also comprises Carua spp. nutshell fragments. The dominance of Carua spp. nutshell, as opposed to Quercus spp. nutshell, could be regarded as evidence of nonrandom selection for hickory nuts. This suggestion is based on both the dominance of oak in the wood charcoal assemblage and the significantly greater frequencies of oaks than hickories in typical oak-hickory forest communities.

It is suggested here, however, that oak acorns were also extremely important, probably even more important than hickory nuts to the Middle Woodland occupants of the Sand Run Slough site. This suggestion can be illustrated by correcting for differential losses in mass weights from carbonization and by converting that product to quantitative estimates of nutmeat weights. Applications of nutmeat:nutshell ratios and nutshell mass conversion factors (for rationale and methods, see Lopinot 1984a:132-154) to the nutshell assemblages from Stratum II and Stratum III are as follows:

Nutshell Taxon	<u>Stratum II</u>		<u>Stratum III</u>	
	Wt (gm)	%	Wt (gm)	%
<u>Carua</u> spp.	1.78	19.3	10.93	65.3
<u>Juglans</u> spp.	.07	.8	2.48	14.8
<u>Quercus</u> spp.	7.35	79.9	2.94	17.6
<u>Corulus americana</u>	--	--	.39	2.3
Totals	9.20	100.0	16.74	100.0

It is reiterated that these data represent the quantities of estimated uncarbonized nutmeats, the real item of dietary significance, represented by carbonized nutshell (the inedible byproduct).

The estimated nutmeat data illustrate potential major differences between the Middle Woodland and the Late Archaic nut exploitation strategies. First, hickory does appear to have been the preferred resource to the Late Archaic occupants of the Sand Run Slough site. Given greater proportions of acorns during fall masts, as is typical today, the dominance of hickory suggests nonrandom selection from a pool of nut resources, quantitatively well beyond any realized carrying capacity. In other words, the natural supplies of nuts far exceeded the Late Archaic occupants' demand. In contrast, the Middle Woodland occupants appear to have utilized acorns much more so than hickory nuts. It is suggested here that the proportions of these two nut types would have been roughly equivalent to their availability in the forests during normal years. If hickory nuts were preferred over acorns, then the dominance of acorns indicates that the Middle Woodland



occupants were exploiting nut masts to their fullest. Consequently, the demands for nuts had caught up with the supplies, and therefore the realized nut carrying capacity had been reached.

Second, and perhaps contradictory to the above argument, is the fact that the data indicate greater nutfood diversity during Late Archaic times than during Middle Woodland times. Walnut shell is significantly more abundant in the Stratum III features than in the Stratum II features. Also, walnut shell occurs in all 11 Late Archaic features but is present in only one Middle Woodland feature. Similarly, hazelnut shell occurs in three Late Archaic features but is entirely lacking in the Middle Woodland features. The reasons for these differences are difficult to explain. The greater overall diversity in nutfoods during the Late Archaic period may be regarded as evidence that there was a desire or need to exploit a greater array of nuts. Alternatively, the content and diversity of resources in the forests surrounding the Late Archaic site may have been quite different from those characterizing the forests surrounding the Middle Woodland site.

The analysis of Carya nutshell specimens also indicates some possible differences between the Late Archaic and Middle Woodland nut exploitation strategies, but many if not all of these differences could be attributed to sampling error. Lobe thicknesses were obtained for 41 nutshell fragments from Stratum II samples and 157 nutshell fragments from Stratum III samples. The Carya nutshell sample from Stratum II has a mean of 1.01 mm, with a range of .2-2.1 mm. The Carya nutshell sample from Stratum III has a mean of .91 mm, with a range of .2-3.0 mm.

The analysis indicates that the vast majority of specimens from both nutshell samples have lobe thicknesses between about .5 and 1.1 mm. These are within the ranges primarily of pecan (Carya illinoensis) and shagbark hickory (C. ovata) nuts, as I have presented elsewhere precorrected for carbonization shrinkage (Lopinot 1984a: Table 8). No obvious specimens of pecan were noted in either of the nutshell assemblages, though several fragments of shagbark hickory appeared to be present. It is likely that most if not all of the nutshell within this lobe thickness range is that of shagbark hickory, since shagbark hickory is a very common tree in mesic forests southeastern Iowa. In contrast, Louisa County is very near the northern limits for the modern distribution of pecan (e.g., see Steyermark 1963; Fowells 1965; Mohlenbrock and Ladd 1978), and presumably the same was true in the past.

Several larger specimens were identified, especially in the Late Archaic nutshell assemblage. Bitternut (C. cordiformis) shell was present in Feature 31 of Stratum II, Area B, as well as in Features 23, 33, and 38 of Stratum IIIa-c, Area B. Specimens apparently of mockernut shell (C. tomentosa) were present in three Stratum III features. These included Features 25 and 34,

Area B and Feature 9, Area C. Finally, a probable shellbark (C. laciniosa) nutshell fragment was present in the sample from Feature 17 of Stratum III, Area C. Doubtless, at least some nutshell fragments having shell lobe thicknesses in the medium range (1.0-2.0) also represent pignut hickory (C. glabra) nuts.

The identification of species among other genera of nuts also was undertaken when possible. Of the 91 walnut shell specimens, all but one are identifiable as shell fragments of black walnut (Juglans nigra). A single specimen from a Late Archaic feature appears to be from a butternut (J. cinerea). The acorn shell fragments generally were too small for identification purposes.

### Seeds

A total SNE of 434 carbonized seeds is represented for the 20 samples. Of these, 393 or about 90% were identified to at least the family level. The total SNE of 434 is represented by 86 whole seeds and 645 seed fragments. Of the total SNE for the site, 251 or 57.8% were represented in two features (Features 25 and 33) from Area B, Stratum III. A single feature from Stratum III (Feature 28, Stratum IIIc) was the only feature to lack carbonized seeds. The taxa-specific SNEs per sample are given in Appendix E. In addition to carbonized seeds, all but two samples from Stratum III features (Feature 27 and 34) contained uncarbonized seeds.

Carbonized seeds were about twice as dense in the Stratum III feature samples (33.5/10 l) than in the Stratum II feature samples (16.3/10 l). The SNE of 109 carbonized seeds for the eight Stratum II feature samples is represented by 43 whole seeds and 98 seed fragments, whereas the SNE of 324 carbonized seeds in the eleven Stratum III features is represented by 43 whole seeds and 545 seed fragments. The SNE counts per taxa are given in Table 6.4.

The differences in density and abundance should not be regarded as evidence that the Late Archaic occupants of the Sand Run west site were more dependent on seeds than the Middle woodland occupants of the site. The greater density of seeds appears to relate only to the intensity of activities and resultant deposition of greater quantities of seeds. In fact, the seed (no.):nutshell (wt. in gm) ratios for the strata would suggest that the Late Archaic occupants were less involved in seed food exploitation than were the later Middle woodland occupants. The seed:nutshell ratio for the Stratum II features is 57.4, whereas it is 22.4 for Stratum III. The real significance of seed exploitation during the Late Archaic period also may be biased by the inclusion of two features (features 25 and 33) which contained abnormally high numbers of seeds. These two features contained 251 or 77.2% of the total carbonized SNE

from the 11 Late Archaic features. The seed:nutshell ratio for the remaining nine samples is 5.6.

The spectra of seeds are quite different among the Woodland and Late Archaic sets of samples. The seed taxa with the eight highest ubiquity indices among the eight Middle Woodland feature samples are as follows:

<u>Chenopodium berlandieri</u>	87.5
<u>Polygonum erectum</u>	50.0
<u>Panicum</u> spp.	50.0
<u>Phalaris caroliniana</u>	37.5
<u>Hordeum pusillum</u>	25.0
<u>Amaranthus</u> spp.	25.0
<u>Zizania aquatica</u>	25.0
<u>Verbena</u> sp.	25.0

Most, if not all of these, represent resources principally in the form of starchy seed foods.

For comparison the five seed taxa with the highest ubiquity indices for the 11 Late Archaic feature samples may be presented. These are as follows:

<u>Chenopodium</u> spp., primarily <u>berlandieri</u>	72.7
<u>Zizania aquatica</u>	45.4
<u>Ambrosia</u> spp.	27.3
<u>Amaranthus</u> spp.	18.2
<u>Polygonum</u> sp., not <u>erectum</u>	18.2

All of the remaining seed taxa (10) are represented by single sample occurrences. Notably, the ubiquity indices indicate at least one if not two or three common denominators. The major commonality is the relatively frequent occurrences of C. berlandieri seeds. Other items which may have been exploited as well during both periods were amaranth, wild rice and knotweed/smartweed.

Table 6.4 also illustrates some of the major differences between the seed assemblages for the Middle Woodland and Late Archaic components. Obviously, the starchy seed complex of chenopod, little barley, maygrass and erect knotweed is well represented in the Woodland features. Panic grass and perhaps amaranth could be added to this complex for the Sand Run West site. These six taxa represent 75 or 86.2% of the identifiable seeds (87) from Stratum II.

In contrast, only chenopod and amaranth seeds represent the starchy seed complex in the set of samples from Archaic Stratum III. Although not identified, it is noted that the two Polygonum spp. specimens from Stratum III samples do not represent erect knotweed seeds. The two starchy seeds, chenopod and amaranth, are represented by 137 or 44.9% of the identifiable seeds (305)

from Stratum III. The differences in representation may be due in part to sampling error. However, it is also reasonable to assume that they reflect real temporal variation in plantfood subsistence strategies.

#### Starchy Cultivated Seeds

The constituents of this seed group are typically considered to be goosefoot, maygrass, erect knotweed and, more recently, little barley. Of course, there are a number of other taxa which also may have been cultivated prehistorically for their starchy seeds or grains. Certain species of panic grass (Panicum sp.) and amaranth (Amaranthus sp.) may be among additional taxa which could be added or, in the case of amaranth, readded to this group. However, since the species of each of these two taxa were not identified, and their probable status as cultivated starchy seeds has not been demonstrated elsewhere, they have been classified herein as weed seeds (see below). Only the four recognized constituents of this group are considered in this section.

Chenopod seeds were represented by whole achenes as well as a wide array of parts. These parts included testa fragments of various sizes, perisperms or fragments thereof, and fragments of embryos. With the exception of two seed fragments in Stratum III samples (Features 25 and 34), all of the chenopod remains were identified as C. berlandieri. Virtually all but a few of the seeds and seed fragments identified to this taxon had alveolate testae or consisted of perisperms associated with alveolate testae. For Stratum II the total SNE of 38 is represented by 14 whole seeds and 48 seed fragments. For Stratum III the total SNE of 130 is represented by 22 whole seeds and 188 seed fragments.

Diameter measurements were obtained for 38 chenopod specimens from Stratum II feature samples and 83 chenopod specimens for Stratum III feature samples. The diameter measurements for these specimens bear out the identification as C. berlandieri, based on recent data provided by D. Asch and N. Asch (1985a, 1985b; also see Cowan 1985). The diameter measurements (in mm) for whole achenes and perisperms lacking embryos were as follows for each of the two seed assemblages:

Table 6.5  
Measurements of Chenopodium Seeds

Diameter (mm)	Stratum II		Stratum III	
	whole	perisperms	whole	perisperms
.6		1		
.7				1
.8		2		3
.9	1	4		4
1.0	2	1	1	10
1.1	5	1	2	17
1.2	8		4	13
1.3	5		8	5
1.4	2		9	2
1.5	1	2	3	1
1.6	2			
1.7	1			
Totals	27	11	27	56

In addition to these measurements the thicknesses of embryo fragments also were obtained whenever possible. Two embryo fragments from two Stratum II features measured .3 mm in thickness. Eleven embryo fragments from Stratum III features had a range of .1-.5 mm, with a mode of .2 mm (7 embryo fragments).

The identification of C. berlandieri seeds in abundance and of common occurrence in deposits dating to at least as early as 2300 B.C. is highly significant. At least in the lower Illinois Valley, several Titterington phase components that date to about the same period of time as the Late Archaic Sand Run West component also are characterized by abundant C. berlandieri seeds (D. Asch and N. Asch 1985a:172, 177). All of the seeds from these Illinois Valley sites are characterized as biconvex with thick alveolate testae. Nearly all of the chenopod seeds in the Sand Run West samples also are biconvex and have thick alveolate testae. Importantly, however, the C. berlandieri seeds from Late Archaic features at Sand Run West also include examples of seeds having truncated margins and what appear to be thin testae. These include three whole seeds from Feature 33 (1.2, 1.4, and 1.5 mm in diameter) and one whole seed from Feature 7 (1.5 mm in diameter). These characteristics, particularly the thin testae, are considered to represent traits specific to domesticated goosefoot.

A few seeds with truncated margins and thin testae also were noted for a few samples from Middle Woodland features. Such seeds are represented in the samples from Features 5b and 31. In addition, one whole seed measuring 1.2 mm in diameter was noted as having a smooth testae. It was present in the sample from Feature 3.

Occurrences of the other three members of the starchy seed complex were restricted entirely to Stratum II feature samples. These included relatively numerous seeds of erect knotweed (Polygonum erectum), but relatively few seeds of both maygrass (Phalaris caroliniana) and little barley (Hordeum pusillum).

Polygonum erectum was represented by six whole seeds and 17 fragments. Most of the 17 fragments consisted of complete or nearly complete kernels. Both reticulated and non-reticulated morphs of P. erectum are represented by whole seeds. Measurements for whole seeds indicate a length range of 1.6-3.2 mm, with a mean of 2.37 mm, and a width range of .8-2.2 mm with a mean of 1.48 mm. Measurements also were obtained for eight whole or nearly whole kernels. For these, the length range is 1.1-2.2, with a mean of 1.74 mm, and a width range of .8-1.5 with a mean of 1.23.

Phalaris caroliniana is represented by two whole grains, one each in Features 5b and 8, and a nearly complete grain in Feature 7. Measurements also were obtained for these three specimens. The seeds have lengths of 1.3, 1.2, and 1.3 mm and widths of .9, .7, and 1.1 mm, respectively. The two specimens of Hordeum pusillum consist of a whole grain from Feature 8 and a nearly complete grain from Feature 31. The whole grain measures 2.4 X .8 mm, whereas the nearly complete grain measures 2.2+ X 1.3 mm. All occurrences of maygrass and little barley comprised naked grains.

#### Oily Seeds

This seed group includes marsh elder (Iva sp.) and sunflower (Helianthus sp.). Both of these seeds are present in Feature 33, the Late Archaic feature for which an abundance of Chenopodium berlandieri seeds was noted. The only other occurrence of a member of the oily seed group consists of a single marsh elder kernel in Feature 5b, Stratum II. This kernel measured only 2.3 X 1.7 mm. Using the adjustments recommended by D. Asch and N. Asch (1985b:382) for loss of pericarp and shrinkage from carbonization, the estimated uncarbonized achene length is 3.3 X 2.53 mm. This size is between the dimensional ranges for Late Archaic and Middle Woodland achene populations from lower Illinois sites and within the range for wild marsh elder populations (see N. Asch and D. Asch 1978:Tables 7 and 8).

Three whole marsh elder kernels and one kernel fragment are present in the sample from Feature 33, Stratum IIIa. Similar adjustments for these kernels results in the following dimensional estimates:

<u>Length</u>	<u>Width</u>
3.30	2.38
3.16	2.53
--	2.67
2.62	2.09

Again, these measurements are within the ranges for achenes of wild marsh elder populations. Although smaller in comparison to the population from the Napoleon Hollow site, all of the measurements for the Sand Run specimens are within the length range for Horizons 6 and 7 (3900-2900 B.C.) of the Koster site (see D. Asch and N. Asch 1985a:Figure 6.3).

Sunflower achenes, identified only as Helianthus sp., are represented by four whole achenes and three achene fragments. These also occur in the sample from Feature 33, Stratum IIIa. Measurements on the four whole achenes, adjusted for carbonization shrinkage as per Waselkov and Yarnell (in Yarnell 1978:296), are as follows:

<u>Length</u>	<u>Width</u>
4.44	1.78
4.22	2.29
4.33	1.78
3.00	1.65

The length:width indices range from about 5.0 to 9.7, relatively small in comparison to collections from other Middle and Late Archaic sites in eastern North America (see Yarnell 1978:Table 1; D. Asch and N. Asch 1985a:Figure 6.5 and Table 6.2). It is notable, however, that one of the achene fragments appears to be from a significantly larger achene than the others. Unfortunately, it consists only of an apical fragment with a small portion of body of the achene still intact.

#### Economic Noncultivated Seeds

Two represented seed taxa have been classified as members of this group--wild rice (Zizania aquatica) and hogpeanut (Amphicarpa bracteata). Wild rice grains comprise the most abundant seed type in the Late Archaic samples, and have the second highest ubiquity index. Wild rice grains are represented by only two whole grains and 302 grain fragments. One whole grain and a grain fragment are present in Features 5b and 9 of Stratum II, whereas the remainder are present in Stratum III features. Of the remainder, the whole grain and 291 grain fragments are present in Feature 25, Stratum IIIb. In addition, grain fragments are present in samples from Features 7, 9, 23, and 34 of Stratum III.

Wild rice is quite frequently represented in seed assemblages in the Great Lakes region, where it was extensively exploited as a staple resource during historic times (see Stickney 1896). Its abundance in Feature 25 and its relatively high ubiquity index for the Late Archaic features is indicative of extensive exploitation of a nearby, quiet-water lake or slough. A number of the wild rice grain fragments, particularly some in the Feature 25 sample, exhibit moderately distorted

appearances and occasional tissue eruptions. However, they are not swollen as described and depicted by Ford and Brose (1975). The specimens from both the Late Archaic and the Middle Woodland features appear to represent fully mature grains.

Hogpeanut is represented by one whole bean and three fragments. Two fragments from one bean represent the only identifiable carbonized seed in the sample from Feature 1 in Stratum I (Late Woodland). The other two seeds consist of a whole bean and a large cotyledon fragment in Feature 38 of Stratum IIc. Ample ethnobotanical evidence has been compiled to indicate that it was widely exploited by Native American groups (e.g., see Yanovsky 1936:37). Carbonized hogpeanut beans were very abundant in a Late Archaic component at the Cahokia site that dated to 1200 B.C. (Lopinot 1983).

#### Weed Seeds

At least 12 different taxa are included within this group. Six taxa are represented in the Middle Woodland feature samples, and eight taxa are represented in the Late Archaic feature samples. Two occur in both sets of samples--amaranth and purslane (Portulaca oleracea).

Whereas examples of uses of several plants within this group could be cited, sound arguments cannot be made with respect to their uses by the occupants of the Sand Run West site. Only grains of panic grass (Panicum sp.) and to a lesser extent seeds of amaranth occur in a sufficient proportion of samples to suggest their possible uses as foods. Also, a single kernel fragment of an achene, identified as giant ragweed (Ambrosia cf. trifida), and a few kernels of dwarf ragweed (A. artemisiifolia) achenes occur in several Late Archaic feature (Features 27, 33, and 34) samples. The kernel of giant ragweed is estimated to have measured 3.0 mm in length and 2.0 mm in width. Considerable evidence exists for intensive utilization and possibly even cultivation of giant ragweed during Late Archaic and Early Woodland times (e.g., see Cowan 1985:214-217).

The taxa belonging to this group are good indicators of the degree of disturbance around a site, regardless of whether or not they are utilized. The fact that weed seeds are relatively more abundant in Stratum II features (20.7% of the identifiable seeds) than in Stratum III features (5.9% of the identifiable seeds) probably reflects an increase in the intentional modification of the surrounding landscape of the Sand Run slough. Taking this one step further, it is suggestive of increased cultivational activities and resultant disturbed habitats where such taxa would have thrived.



## Other Seeds

This catch-all group includes some rather unusual seed taxa. Avens (Geum canadense) and jewelweed (Impatiens sp.) seeds are good indicators of open forests in rich bottomlands, ravines, and slopes. The avens seed is represented by a whole kernel. The avens achene likely comprised an inadvertant "hitch-hiker" which, like bedstraw (Galium sp.) and tick-trefoil (Desmodium sp.), probably became attached to clothing, hair or some other host, was brought to the site, and was picked free and discarded.

The presence of the jewelweed seed is more difficult to explain, particularly since the seeds are relatively large. The young stems of this plant are noted as being edible (Medsger 1966: 167), and the abundant juice in the stems are commonly used for medicinal purposes, particularly in the prevention or treatment of poison ivy rashes.

The possible silver maple seed consisted of a complete seed body. It is the correct size and shape for silver maple (Acer saccharinum), except that the remainder of the samara had apparently burned away preventing any type of conclusive identification. Silver maple also thrives in low wet, open forested places, especially along sunlit edges of bodies of water.

## Summary

The analysis of plant remain has demonstrated that: (1) fuel wood collection strategies were generalized, involving exploitation from a wide range of habitats; (2) nuts, particularly hickory nuts and acorns, were important during both the Late Archaic and Middle Woodland periods; and (3) seed foods were quite diverse during both periods of time. The major difference between the two periods relates to the relative importance or increased intensity of horticultural activities during at least Middle Woodland times.

The identification of certain taxa, particularly from the Late Archaic component of the Sand Run West site, has important ramifications in understanding the evolution of agricultural systems in eastern North America. In particular, the identification of relatively abundant Chenopodium berlandieri along with several other taxa from deposits dating to ca. 2100-2300 B.C. adds to a growing body of evidence indicative of widespread involvement with these plants during the Late Archaic period. The other taxa minimally include marsh elder, sunflower and giant ragweed.

The basic plantfood subsistence strategy during the deposition of Stratum III, or during the Late Archaic occupation, revolved around hickory nuts, walnuts, acorns, chenopod seeds, wild rice and possibly edible underground stems. Other foods of

probable significance included the achenes of ragweed, sunflower and marsh elder. Whereas strong evidence for horticulture is lacking, the suite of represented oily and starchy seeds is suggestive of some form of cultivational activity. D. Asch and N. Asch (1985b) have argued for cultivation of sunflower and marsh elder, as well as perhaps chenopod and ragweed during the Late Archaic period in the lower Illinois Valley. At least one of the kernel fragments of sunflower from Feature 33 appears to represent a very large achene, perhaps of a semi-domesticated or fully domesticated sunflower. Although rind or seeds of gourd and squash were lacking from the Stratum III samples, intensive examination of more samples from these contexts may demonstrate the presence of one or both. Evidence which has accumulated during the last decade has amply demonstrated that both were being cultivated in many places in the midwest during the Late Archaic period (e.g., Chomko and Crawford 1978; Kay et al. 1980).

The samples from Stratum II have demonstrated a fairly well developed horticultural complex not unlike that which has been noted for Middle Woodland components to the south. This complex includes chenopod, little barley, maygrass, erect knotweed, squash and possibly panic grass. Other possible additions to this complex minimally would include amaranth and marsh elder.

Hickory nuts and acorns continued to be important, as possibly were edible underground stem foods. However, acorns apparently replaced hickory nuts as the more heavily exploited nut resources. Also, walnut appears to have been of very minor importance, in contrast to the pattern of extensive use as a secondary food source during the Late Archaic period.

The absence of hazelnut shell in the Middle Woodland archaeobotanical assemblage is intriguing, particularly in light of its dominance in many Middle Woodland assemblages from sites to the southeast and south in the lower Illinois Valley and latitudinally comparable parts of the Mississippi Valley (e.g., King and Roper 1976; N. Asch and D. Asch 1980; Lopinot 1984b; D. Asch and N. Asch 1985b). The possible explanations for the significantly heightened importance of hazelnuts characterizing only the Middle Woodland period have been many, but it does appear that not all Middle Woodland groups in Illinois (e.g., in the American Bottom), Missouri and now Iowa participated in this "experiment".

Also of interest is the fact that identifiable fleshy fruit remains are entirely lacking from both the Stratum II and Stratum III samples. Such remains tend to occur commonly in both Late Archaic and Middle Woodland archaeobotanical assemblages (e.g., see Munson et al. 1971; Asch et al. 1972; Lopinot 1984b; D. Asch and N. Asch 1985b). Their absence may be due to a number of factors. These include sampling error, their relative unimportance in the diet, the offsite processing of fruits and discard elsewhere of inedible parts, the nonuse of the site during periods of peak fruit production (July-early September),

or a combination of these. Certainly, their absence is rather unusual.

In summary, the archaeobotanical assemblage from the Late Archaic component contains a rather diverse array of resources suggestive of a generalized resource procurement strategy. Although unproven, it is tempting to suggest the cultivation minimally of goosefoot, marsh elder and sunflower by the Late Archaic occupants. An assortment of nut resources, but especially hickory nuts, and the grains of wild rice also were intensively exploited by the Late Archaic occupants of the Sand Run West site. The information obtained from this site adds to the growing body of archaeobotanical data on Late Archaic subsistence strategies in eastern North America.

Likewise, the archaeobotanical assemblage from the Middle woodland component of the site illustrates that the Middle woodland subsistence strategy represents variation on a common theme which existed throughout this portion of the midcontinent. This theme also was a very generalized one, involving considerable dependence on the cultivation of a wide latitude of seed foods. During the Middle Woodland occupation of the Sand Run west site, these minimally included goosefoot, erect knotweed, maygrass, little barley and squash. Others such as marsh elder and panic grass might be added to this list in the future. As with the Late Archaic occupation, however, collection of nuts, particularly acorns in this case, and certain other naturally available foods continued to occupy a significant portion of their food procurement efforts.

ADDENDUM  
ARCHAEOBOTANY STUDY

by David W. Benn

During the course of excavations, nine liter soil samples were retained from each cultural level and every pit or hearth feature. This soil was returned for processing to the Center for Archaeological Research. The samples were remeasured and air-dried for a few days to assist in deflocculating the clays. Drying sometimes increases the amount of breakage in some carbonized materials, but it also greatly speeds the process of floating and screening the soil matrix. Floating involved pouring the soil matrix into a bucket of water and gently agitating the water until all lumps of soil had broken into individual sediment grains. Floating carbon was poured into a #40 mesh brass screen, while the heavy fraction was sieved through nexted screens, the smallest being one-sixteenth inch (fly) screen. Light and heavy fractions were air-dried on newspaper.

The samples (Table 6.1) were picked by the writer to remove seeds and nut shell. Light fractions were sorted under a 10X binocular microscope. Heavy fractions were picked by eye for carbon, bones and flakes. Then, carbon, bone and lithic remains were sorted and distributed to specialists for analysis. Neal Lopinot received a selection of the most prolific carbon samples regardless of their species content. The carbon samples had to be sub-sampled for Lopinot's analysis because of time and monetary constraints.

The writer sorted all samples not sent to Lopinot for seeds that represent the native seed complex and for wild rice. This was done to confirm that Lopinot's findings applied to the rest of the assemblage. Samples producing horticultural seeds and wild rice are presented in Table 6.6. Chenopodium berlandieri is nearly ubiquitous, and wild rice also occurs in many samples, especially in the Late Archaic Stratum III. A single sunflower fragment with achene also came from Stratum III feature 2. Although broken, the sunflower fragment is slightly wider than 1.8mm (corrected measurement). No other horticultural seeds were found, nor was any squash rind recognized in the Late Archaic samples. These findings correlate with Lopinot's results.

Table 6.1  
Soil Samples Processed  
by Flotation  
13LA38

Block Stratum	lev/tea	Provenience	Liters of soil	Block		Liters of soil
				Stratum	lev/tea	
A II	tea 2	pit	8	C I	lev 1	9
	tea 6	pit	6		lev 2	9
	tea 8	pit	6		lev 3	9
	tea 9	pit	9		lev 4	9
B II	lev 7	gen	9		lev 5	9
	lev 8	gen	9		fea 1	4.5
	lev 3	pit	9	II	lev 6	9
	lev 4	pit	9		lev 7	9
	lev 6	pit	9		lev 8	9
	lev 7	pit	9		lev 9	9
	lev 9	hearth	9		lev 3	2
	lev 11	pit	9		lev 5b	7
	lev 12	gen	9	III	lev 10	9
	lev 18	hearth	9		lev 11	9
IIIa	lev 19	dump	7		lev 12	9
	lev 33	hearth	9		lev 13	9
	lev 34	pit	9		lev 14	9
	lev 23	hearth	9		lev 15	9
IIIb	lev 24	hearth	9		lev 16	9
	lev 25	pit	9		lev 2	9
	lev 35	pit	9		lev 7	9
	lev 36	hearth	9		lev 8	7
IIIc	lev 16-17	gen	9		lev 9	7
	lev 27	pit	9		lev 10	9
	lev 28	hearth	9		lev 12	9
	lev 29	pit	9		lev 14	9
	lev 37	hearth	9		lev 15	8
	lev 38	pit	9		lev 16	9
					III T.U.7 fea 7-1	hearth

Table 6.2

Counts (ct) and Weights (wt-gm)  
for Major Classes of  
Archaeobotanical Materials

Debris Type	Stratum II			Stratum III			
	ct	wt	%	ct	wt	%	
Fuel/Construction Remains				Totals	ct	wt	%
Wood Charcoal	702	5.88	72.9	66.7	424	3.22	14.3
Bark	22	.32	2.3	3.6	1289	11.44	43.4
Twig Fragments	-	-	-	-	2	.04	.1
Fungal/Tissues	-	-	-	-	3	.01	.1
Grass/Herb Stems	p						t
Subtotals	724	6.20	75.2	70.3	1718	14.71	57.9
							48.6
Nutshell Remains							
<i>Carya</i> spp.	92	1.35	9.6	15.3	511	8.29	17.2
<i>Juglans</i> spp.	4	.07	.4	.8	87	2.49	2.9
Juglandaceae	56	.38	5.8	4.3	528	3.52	17.8
<i>Quercus</i> spp.	20	.10	2.1	1.1	14	.04	.5
<i>Corylus americana</i>					8	.10	.3
Subtotals	172	1.90	17.9	21.5	1148	14.44	38.7
							47.7
Underground Stems							
Tubers/Rhizomes	26	.46	2.7	5.2	43	.54	1.4
Bulbs	-	-	-	-	p		1.8
Squash Rind	p						-
Unidentified	41	.26	4.2	2.9	60	.57	2.0
							1.9
TOTALS	963	8.82	100.0	99.9	2969	30.26	100.0
							100.0

Table 6.3

## Wood Charcoal Identifications

Wood Taxa	Stratum II		Stratum III	
	Ct	%	Ct	%
<u>Acer</u> cf. <u>rubrum</u>	4	2.7	2	1.4
<u>Acer</u> spp.	5	3.4	4	2.7
<u>Carya</u> spp. (true type)	13	8.9	20	13.7
<u>Carya</u> spp. (pecan type)	1	.7	-	-
<u>Carya</u> cf. <u>Cordiformis</u>	1	.7	3	2.0
<u>Carya</u> sp. (indeterminate)	-	-	4	2.7
<u>Celtis/Ulmus</u> spp.	11	7.5	13	8.9
<u>Fraxinus</u> spp.	15	10.3	9	6.2
<u>Gleditsia/Gymnocladus</u> spp.	4	2.7	1	.7
<u>Gleditsia triacanthos</u>	-	-	3	2.0
<u>Juglans</u> spp.	6	4.1	7	4.8
<u>Morus rubra</u>	2	1.4	2	1.4
<u>Populus/Salix</u> spp.	8	5.5	13	8.9
<u>Salix</u> spp.	2	1.4	-	-
cf. <u>Prunus</u> spp.	1	.7	-	-
<u>Quercus</u> spp. (white)	62	42.5	48	32.9
<u>Quercus</u> spp. (red)	9	6.2	5	3.4
<u>Quercus</u> spp. (indeterminate)	1	.7	10	6.8
<u>Tilia americana</u>	1	.7	2	1.4
Subtotals	146	100.1	146	99.9
Knotwood			4	
Ring Porous	5		43	
Semi-ring Porous	2		1	
Diffuse Porous	4		9	
Indeterminate	3		17	
TOTALS	160		220	

Table 6.4

Carbonized Seed Number  
Estimates (SNE) per Taxon

	Stratum II		Stratum III	
	SNE	%	SNE	%
<b>Starchy Cultivated Seeds</b>				
<u>Chenopodium</u> spp.*	38	43.7	130	42.5
<u>Hordeum pusillum</u>	3	3.4	-	-
<u>Phalaris caroliniana</u>	2	2.3	-	-
<u>Polygonum erectum</u>	22	25.3	-	-
Subtotals	65	74.7	130	42.5
<b>Oily Seeds</b>				
<u>Helianthus</u> sp.	-	-	7	2.3
<u>Iva</u> sp.	1	1.1	4	1.3
Subtotals	1	1.1	11	3.6
<b>Economic Noncultivated Seeds</b>				
<u>Amphicarpa bracteata</u>	-	-	2	.7
<u>Zizania aquatica</u>	2	2.3	141	46.2
Subtotals	2	2.3	143	46.9
<b>Weed Seeds</b>				
<u>Amaranthus</u> spp.	4	4.6	7	2.3
<u>Ambrosia artemisiifolia</u>	-	-	3	1.0
<u>A. cf. trifida</u>	-	-	1	.3
cf. <u>Amorpha canescens</u>	-	-	1	.3
<u>Desmodium</u> sp.	1	1.1	-	-
<u>Galium</u> sp.	-	-	1	.3
<u>Panicum</u> sp.	8	9.2	-	-
Poaceae	-	-	1	.3
<u>Polygonum</u> sp.	-	-	2	.6
<u>Portulaca oleracea</u>	2	2.3	2	.6
<u>Verbascum</u> sp.	1	1.1	-	-
<u>Verbena</u> sp.	2	2.3	-	-
Subtotals	18	20.7	18	5.9
<b>Other Seeds</b>				
cf. <u>Acer saccharinum</u>	1	1.1	-	-
Fabaceae	-	-	1	.3
<u>Geum canadense</u>	-	-	1	.3
<u>Impatiens</u> sp.	-	-	1	.3
Subtotals	1	1.1	3	1.0
Unidentified	22		19	
TOTALS	109	99.9	325	100.0

\*Includes all seeds identified as C. berlandieri, as well as those identified only as Chenopodium spp.



Table 6.6  
 Selected Seed Species from  
 Samples Not Processed for the Archaeobotany Study

Block	Providence		Zizania	Chenopodium	Helianthus	
	Stratum	lev/fea				
A	II-6	fea 2	-	2	-	
B	II	lev 8 gen	1	2	-	
		fea 4	-	3	-	
C	II	lev 9 gen	-	2	-	
Middle Woodland subtotal			1	9	0	
B	IIIa	fea 19	-	1	-	
		IIIb	fea 2	-	12	frag.
		fea 18	2	1	-	
		fea 35	1	-	-	
		fea 36	1	1	-	
C	III	lev 11 gen	-	1	-	
		lev 13 gen	-	2	-	
		lev 14 gen	-	6	-	
		fea 10	-	1	-	
		fea 12	1	-	-	
		fea 15	2	1	-	
Late Archaic subtotal			7	26	1	

## VII FAUNAL REMAINS

The aboriginal occupants of the Sand Run site may have left abundant evidence of the animals they captured and consumed. Unfortunately, the site's soils are not conducive to bone preservation. The buried and surface soils developed beneath forests, and the A and B soil horizons are leached and mildly acidic. There are middens and trash pits in the soils composed of dense masses of cultural debris. Here, bone preservation was better because the high organic content changed the natural soil chemistry. Thus, bone preservation was variable across the site; never adequate to preserve a complete range of aboriginal evidence but good enough to reveal broad patterns of faunal exploitation from some components.

Two kinds of faunal samples were obtained. All bones found during excavation and recovered from one-quarter inch field screens are tabulated in Tables 7.1 and 7.2. Generally, these bones, hereafter called "excavated bones," were in poor condition because they were difficult to extract from the soil without damage. Bones in the soil tended to be cracked and soft and were about the same hardness as the surrounding soil. Many bones were removed in a block of soil matrix, but they were just as friable in the laboratory. The other kind of bone sample was obtained from soil samples floated in the laboratory. Recovery by flotation and screening through one-sixteenth inch mesh yielded larger numbers and smaller sizes of bones than the field sample. "Floated bone" remains are listed in Tables 7.2, 7.4 and 7.5.

Excavated bones were sorted and identified by the writer. A handful of excavated bones representing unidentifiable birds, canids, human and miscellaneous categories were sent to Lucretia Kelly (Columbia, Illinois) for identification. All floated bone samples, except fish vertebrae, also were sent to Kelly for identification. Eight human teeth were evaluated by George Milner (Pennsylvania State University at State College), and a human cranium and mandible were analyzed by personnel of the Office of State Archaeologist, Iowa.

### The Assemblage

All of the bones processed and tabulated in the laboratory amount to 3949 pieces. Of these, 389 (10%) were identified to species or family. The rest (90%) are mainly small fragments that can be identified to class but provide no useful information about habitat preference. A large proportion of the assemblage, 1248 bones (32%), is calcined or burned bone, which is more likely to be preserved under acidic soil conditions.

The methods by which bones were recovered has some influence on the composition of the assemblage. The 1593 excavated bones include 734 (46%) calcined pieces, while calcined pieces comprise 22% (514) of the 2350 floated bones. Apparently, hard, white calcined bones are more visible and easier to recover than soft unheated bone in hard soil conditions. Water separation of bones and soil matrix yielded more unheated bone, especially bones of a wider range of sizes. Recovery of non-calcined fish remains was notably better in flotation samples.

The conditions of bone preservation can be visualized in the data in Table 7.1. Stratum I (Late Woodland period) in the site's topsoil has almost no bone preservation, not even calcined bones. The few bones present were well preserved and probably represent intrusions of modern faunal remains into the site. Among these intrusions are raccoon (P. lotor) and elk (C. canadensis) bones and a fragment of mussel shell (the only shell from the site). Stratum II (Middle Woodland period) in a buried soil yielded a small sample of bones, mostly calcined. Much of sample came from pit features. Lacking non-calcined bones, the Stratum II sample cannot be taken as representative of aboriginal use of fauna. Stratum III (Late Archaic period), a deeply buried midden soil, yielded the largest number of bones. A majority of the bones were not calcined. Bones were concentrated in the lower levels (C14, C15; B15, B18) with other cultural remains like fire-cracked rock. The Stratum III sample with bones from many proveniences can be considered broadly representative of aboriginal fauna exploitation.

The faunal assemblage is analyzed below by sample type (i.e. excavated, floated) and animal class.

Excavated bones: (Table 7.2)

Except for calcined turtle bones, there are no other animal species represented in Strata I and II. Preservation of bones in the Late Archaic levels was dependent on associations in pit features and in middens or on extremely deep burial (e.g. Stratum IIIc, Block B).

Mammals: White-tailed deer (O. virginianus) elements dominate the assemblage. Many unidentified bone fragments also represent longbone splinters from this species. Raccoon, beaver (Castor canadensis) and Canis spp. elements also occur in several levels, while squirrel has three occurrences. Most of an articulated dog skeleton came from level 11 Stratum III, although this probably was a dog interred in a Middle Woodland pit that extended into the Archaic component (a fragment of a ceramic pipe stem was found with the dog). An Archaic pit yielded many broken elements of a large canid skeleton the size of a wolf. Neither the dog or "wolf" skeleton was adequately preserved to study tooth eruptions or element sizes. A calcined fragment of cut (sawn?) deer antler also was recovered from Stratum IIIb, Block B.

Humans: Isolated molar teeth were found in two Archaic levels and one feature. One of these teeth (level 14 Block C) was identified by George Milner as an upper left second molar from a person about 11-13 years old. In level 11 Stratum IIIa (Block B) a complete human cranium and mandible were recovered in a very soft, crumbly condition. These remains were in the general midden, not buried in a pit. A report of these remains is appended (Appendix F).

Birds: Only three elements were recovered. They included a duck (A. platyrhynchos), turkey (M. gallopavo) and a large bird (not goose or turkey). This sample is inadequate for analysis.

Turtles: Calcined turtle shell was the only ubiquitous remains in the samples. Some cultural practice must be responsible for the high incidence of heated turtle shell. Perhaps turtle shell bowls were commonly used around the hearth locus (cf. Styles, Purdue and Colburn 1985:434). A turtle shell fragment with numerous scraping marks (tool striations) was found in level 8 Stratum II Block C. The only turtle species positively identified is Trionyx (soft-shell turtle) because of the distinctive pebbled surface of the shell. Bowls were not made from this species. According to variations in shell element shape other water species and the box turtle also are present and were made into bowls.

Fish: Only elements of fish from the catfish family (Ictaluridae) and drum (A. grunniens) were identified. The small numbers of fish remains from excavated proveniences is a reflection of poor recovery from quarter inch field screens and the small, fragile nature of these bones. One element, however, was from a very large member (e.g. +15 lbs.) of the catfish family.

Floated Bones: (Tables 7.3, 7.4, 7.5):

The assemblage of bones from floated soil, both general level and feature samples (see Table 6.1), is not more diverse in terms of species. But, there is much better recovery of small fish remains from all components at the site.

Mammals (Tables 7.3, 7.4): Elements from mammals are not more numerous in floated samples. Muskrat (Q. zibethicus), raccoon, canids and deer are each represented by a few elements. Bones from small rodents (Cricetidae) are common, but few elements are teeth useful for identification. The unidentified bone fragments show a preponderance of medium to large sized creatures.

Humans (Table 7.4): Five molars, a canine fragment and an incisor were washed from feature 31 Stratum II Block B. These were probably articulated, the jaw bones having been so soft they dissolved in water. George Milner observed that this individual was 2-3 years in age.

Birds: Only mallard duck bones were identifiable. A sternum fragment from a large bird also is present.

Turtles: Calcined turtle bone is, again, ubiquitous, but many shell fragments from Block C Archaic levels are not heated. Soft-shell turtle is identified, and other water and box turtles also seem to be represented.

Snakes: A number of snake vertebra were recovered from Archaic Stratum III, especially in Block C. Two of these are calcined, but there is no other direct evidence that snakes were utilized by the Sand Run inhabitants. The recovery of snake elements correlates with that of fish bones.

Fish (Table 7.5): The "indeterminant" category consists mostly of vertebra. The identified elements are dominated by the catfish family, especially bullheads (Ictalurus spp.), although three elements are from medium and large sized catfish. Other significant species include the bowfin (A. clava), sucker (Catastomidea) and drum. Species of the sunfish (Lepomis sp.), pike (Esox sp.), gar (Lepisosteus sp.) and minnow (Cypinidae) families are uncommon. The high incidence of bullheads indicates exploitation of backwater channels. The suckers are small-sized; suckers are spawned in the shallows of small streams. Gar and drum are more indicative of large rivers, but they enter backwater communities during flood stages. Generally, the habitat preferences of species in the collection match the slough conditions in front of the Sand Run site. The small size of most of the fish suggests they were captured with nets or scooped from drying backwater lakes.

### Discussion

Interpretations are limited to comments about bones that are present, since preservation problems have caused an obvious skewing in the representation of species (e.g. too few aquatic birds, mussels and deer). Generally, the assemblage is dominated by aquatic creatures (fish, turtles), woodland/edge species (deer, raccoon) and canids (presumably dogs). This is the typical pattern for woodland culture occupations in large valleys of the Midwest (Parmalee et al. 1972; Styles, Purdue and Colburn 1985:434). It also may be an emerging pattern for Late Archaic populations, if this writer is catching the common sentiment among research archaeologists in the Midwest. One species that is conspicuous by its absence is elk, a creature of the prairie. A few elk bones are in the surface collection from 13LA30, but elsewhere in eastern Iowa elk bones are not frequently represented in Woodland and Late Archaic assemblages.

Of course, exploitation of the prairie habitat could have occurred during seasons when the Sand Run site was not occupied. There are virtually no good seasonal indicators in the Sand Run bone assemblage, except annuli in the vertebra of fish (Appelget

and Smith 1950; Casteel 1972). Hundreds of vertebra were recovered in various states of preservation. Most did not retain their spines but the centra were frequently intact. Thus, identifications of species were not attempted from vertebra, but a sample was analyzed for seasons of death by noting the relative location of the last annulus. Lacking species control, this exercise is not intended to be an exacting study. Rather, the composition of seasons is sought.

Flotation samples containing the most vertebra were selected for analysis. Only bones retaining the centrum margin and exhibiting clearly defined annual rings and annuli (i.e. dark or clear winter growth ring) were read. Following Casteel (1972:408), three "seasons" were identified:

- vertebrae with annulus on the margin (March-June);
- vertebrae with a small amount of growth after the annulus (July-October);
- vertebrae with much growth after the annulus (November-February).

Table 7.6  
Seasons of Death in  
Sand Run Fish Vertebrae

provenience	March-June	July-October	November-February
Stratum II fea.s B9, B3 B4, C5b, C.lev8	n=6 35%	3 18%	8 47%
Stratum III fea.s C2, C7, C8, C9, C12, C14, B23, B27, B29, B36, B37 B38	n=71 36%	65 32%	64 32%

When reading this data, it is important to note that Casteel (1972:409) found a 12-14% error of inconsistent readings in his samples. The whole sample size for Stratum II is low, and the July-October percentage approaches the size that Casteel mentioned for his rate of error. Spring and late Fall-Winter seasons represent most of the kills in Stratum II. The Late Archaic Stratum III data are explicit in showing fish kills throughout the year. It appears that Late Archaic people took fish regularly and during the entire year. A year-round pattern is not consistent with the widespread conception that most wild resources were exploited seasonally, for instance the Stratum II pattern.

Table 7.1  
13LA38  
Tabulation of All Bone Remains  
from General Excavations

Stratum Level		Calcined/burned frags	Unheated frags	I.D.	
				calcined	unheated
Block A I	1	-	-	-	-
	2	-	-	-	-
	3	-	-	-	-
	4	2	-	-	-
	1 fea	-	-	-	-
	II	5	1	-	-
	6	-	-	2	1
	7	-	-	-	-
	9 fea's	6	-	2	-
Block B I	5	-	-	-	-
	6	-	-	-	-
	II	7	6	-	1
	8	8	-	-	-
	9-10	4	-	-	-
	15 fea's	41	-	6	-
	IIIa	11	-	-	+1
	12	3	-	-	-
	13	1	-	-	-
	14	17	+9	2	1
	7 fea's	23	6	-	-
	IIIb	15	40	+43	3
	16	30	16	1	2
	17	16	2	-	3
	5 fea's	11	-	-	1
	IIIc	17	28	7	2
	18	9	+51	-	2
	19	3	+31	-	1
	20	-	-	-	-
	7 fea's	2	+38	-	9
Block C I	1	-	1	-	2
	2	-	-	-	1
	3	4	2	-	1
	4	-	1	-	-
	5	4	-	-	-
	II	6	20	-	1
	7	22	1	2	-
	8	34	-	3	-
	9	35	2	3	1
	1 fea	+14	3	-	-
	III	10	37	11	-
	11	34	8	1	4
	12	33	41	-	6
	13	+80	42	1	16
	14	+113	+125	-	38
15	+19	+32	-	11	
13 fea's	5	+243	1	29*	
Totals	+705	+717	29	+141	

\*plus 2 "dog" skeletons

Table 7.2: Identified Faunal Remains, 13LA38 General Excavations.

Species	Block A					Block B					Block C					Totals			
	I	II	III	IV	V	1	II	III	IV	V	1	II	III	IV	V				
<u>Striatum</u> lev.	1	2	3	4	5	6	7	8	9-10	11	12	13	14	15	16	17	18	19	20
<b>Mammals</b>																			
<u>Squirrel</u> <u>Sciurus</u> spp.																			
<u>Raccoon</u> <u>P. lotor</u>																			
<u>Beaver</u> <u>C. canadensis</u>																			
<u>Dogs</u> <u>Canis</u> spp.																			
<u>deer</u> <u>O. virginianus</u>																			
<u>Elk</u> <u>C. canadensis</u>																			
<u>Human</u> <u>H. sapiens</u>																			
<b>Birds</b>																			
med. duck <u>Anas</u> sp.																			
turkey <u>M. gallinago</u>																			
lg. bird (not goose)																			
<b>Amphibians &amp; reptiles</b>																			
softshell turtle <u>Trionyx</u> sp.																			
misc. turtle																			
Snake																			
<b>Fish</b>																			
cattfish family <u>Ictaluridae</u>																			
drum <u>Aplodinotus grunniens</u>																			
misc. species																			
<b>Freshwater mussels</b>																			



Table 7.4  
Faunal Remains from Flotation Samples  
13LA38 Block B

Species	Block B		II		IIIa		IIIb		IIIc		T07								
	Lev. lev	fea#	18	33	23	24	25	35	36	lev	fea#	37	38	7-1	Totals				
<u>mammals</u>																			
small rodents																			
muskrat <u>O. zibethicus</u>	-	-	1	-	-	1	-	-	-	1	-	1	-	-	5				
raccoon <u>P. lotor</u>	-	-	-	-	-	-	-	-	-	-	-	1	-	-	1				
dog <u>Canis</u> pp.	-	-	-	-	-	-	-	-	-	-	-	-	-	-	0				
deer <u>O. virginianus</u>	-	-	-	-	-	-	4	-	-	-	-	-	1	-	5				
human <u>H. sapiens</u>	-	-	-	-	-	-	-	-	-	-	-	-	-	-	7				
indeter. small	-	-	-	-	-	-	-	-	1(1)	-	-	2	-	-	2				
trags - medium	-	-	-	-	-	-	-	-	-	-	-	-	-	-	1(1)				
med-large	-	-	-	-	-	-	-	4(4)	-	-	-	5	-	-	9(4)				
large	-	-	-	-	-	-	-	-	-	-	-	-	-	-	1				
no size	-	-	-	-	-	-	-	-	-	-	-	-	-	-	0				
<u>birds</u>																			
duck <u>A. platyrhynchos</u>	-	-	-	-	-	-	-	-	-	-	-	2	-	-	2				
indeter.	-	-	-	-	-	-	-	-	-	-	1(1)	1	1	-	14(1)				
<u>turtle</u>																			
softshell <u>Trionyx</u> sp.	-	-	-	-	-	-	-	-	-	-	-	-	-	-	0				
indeter.	2(2)	2(2)	2(2)	2(2)	2(2)	-	-	-	1(1)	-	2	1	-	-	39(38)				
<u>snake</u>																			
indeter	-	-	-	-	-	-	-	1	-	-	-	1	-	-	2				
indeter. to class	-	3(3)	4(4)	9(8)	5(5)	6(6)	5(5)	16(16)	44(42)	5(4)	54(52)	31(28)	-	24(8)	21	21(1)	25(5)	273(187)	
																			361(231)

Identifications by Lucretia Kelly  
All samples are 9 liters  
(# calculated or burned)

Table 7.3: Faunal Remains from Flotation Samples, 13LA38 Blocks A and C.

Species	Block C																					
	6	7	8	9	10	11	12	13	14	15	16	17	18	19	20	21	22					
<u>mammals</u>																						
small rodents					1(1)																	
muskrat <i>O. zibethicus</i>																						
raccoon <i>P. lotor</i>																						
dog <i>Canis</i> spp.																						
deer <i>O. virginianus</i>																						
indeter. small																						
medium																						
med. large																						
large																						
no. size																						
<u>birds</u>																						
duck <i>A. platyrhynchos</i>																						
indeter.																						
<u>turtle</u>																						
softshell <i>Trionyx</i> sp.																						
indeter.																						
<u>snake</u>																						
indeter.																						
indeter. to class	2(2)	7(7)	5(5)	5(5)	7(6)	10(6)	8(6)	8(8)	25(14)	14(5)	2(2)	2(2)	3(2)	20(8)	14(5)	50(4)	40(6)	64(6)	52(5)	100(4)	44(6)	25(9)

Species	Block A									Block C																
	2	6	8	9	Totals	6	7	8	9	10	11	12	13	14	15	16	17	18	19	20	21	22				
<u>mammals</u>																										
small rodents																										
muskrat <i>O. zibethicus</i>																										
raccoon <i>P. lotor</i>																										
dog <i>Canis</i> spp.																										
deer <i>O. virginianus</i>																										
indeter. small																										
medium																										
med. large																										
large																										
no. size																										
<u>birds</u>																										
duck <i>A. platyrhynchos</i>																										
indeter.																										
<u>turtle</u>																										
softshell <i>Trionyx</i> sp.																										
indeter.																										
<u>snake</u>																										
indeter.																										
indeter. to class	6(5)	3(3)	3(3)	9(9)	526(141)	9(2)	1	1	1	7	3	2	1	1	1	1	1	1	1	1	1	1	1	1		

identifications by Lucretia Kelly  
 all samples are 9 liters except:  
 (A) 2(8 L.), A fee 6(7 L.), A fee 8(6 L.),  
 (B) 5(4 L.), C fee 8(7 L.), C fee 9(7 L.),  
 (C) 1(4.5 L.), C fee 3(2 L.),  
 (D) 15(8 L.)

Table 7.5  
Fish Remains from Flotation Samples  
13LA38

Species	Block A							Block B							Block C							Totals									
	II			III				II			III				II			III													
	lev	10	11	12	13	14	15	16	17	18	19	20	21	22	23	24	25	26	27	28	29		30	31	32	33					
Gar <u>Lepisosteus</u> sp.																															
bowfin <u>Ameiobos</u>																															
bowfin or Pike <u>ESOX</u> sp.																															
Ictaluridae																															
bullhead <u>Ictalurus</u> sp.																															
Minnows <u>Cyprinidae</u>																															
Catostomidae																															
buffalo sucker <u>Ictalurus</u> sp.																															
Centrarchidae																															
Sunfish <u>Lepomis</u> sp.																															
Bass <u>Micropterus</u> sp.																															
drum <u>Aplodinotus grunniens</u>																															
indeter. fish																															
2																															
3																															
5																															
Block A																															
II																															
lev.	2	6	8	9																											
lev.																															
Block B																															
II																															
lev.	7	8																													
lev.																															
Block C																															
II																															
lev	6	7	8	9	10	11	12	13	14	15	16	17	18	19	20	21	22	23	24	25	26	27	28	29	30	31	32	33	34	35	
lev																															
Species																															
Gar <u>Lepisosteus</u> sp.																															
bowfin <u>Ameiobos</u>																															
bowfin or Pike <u>ESOX</u> sp.																															
Ictaluridae																															
bullhead <u>Ictalurus</u> sp.																															
Minnows <u>Cyprinidae</u>																															
Catostomidae																															
buffalo sucker <u>Ictalurus</u> sp.																															
Centrarchidae																															
Sunfish <u>Lepomis</u> sp.																															
Bass <u>Micropterus</u> sp.																															
drum <u>Aplodinotus grunniens</u>																															
indeter. fish																															
Totals																															

Identifications by Lucretia Kelly

## VIII INTERPRETATIONS

This chapter is divided into two parts. The first deals with the natural context of archaeological deposits through pedological and geomorphological evidence. The second is about prehistoric periods and culture processes in the Three Rivers region and the Midwest.

### Site Preservation and Natural Contexts

Nowadays, the first questions we ask about a region's prehistory are: where in the landscape are sites most likely to be located, and what conditions of preservation can be anticipated? The geomorphic contexts of cultural materials and radiocarbon dates from Sand Run do not provide answers to these profound issues, for Sand Run is but a single locus in the massive Mississippi Valley. The Sand Run evidence does illuminate avenues for research that could lead to modelling of site contexts on the valley floor.

The conditions of site preservation have to do with evidence that is preserved in spite of the effects of soil chemistry, leaching in the soil, transportation by moving water, tree falls and mixing due to burrowing animals. The latter effects--water and biota--are constant factors in a floodplain environment. The impacts of water, tree growth and burrowing animals will vary across small areas of the site depending on proximity to the water source and elevation of the ground above the water table. Both effects would have been contemporary with the prehistoric occupation and would have continued through archaeological time.

The impact of leaching may be amenable to modelling over broad areas. Forest soils, for instance, have heavily leached E horizons where cultural evidence is likely to be physically destroyed by turbations and likely to be chemically reduced because of acidic pH. If the A horizon in a forest soil is not cumulic because regular additions of overbank alluvium bury the surface, materials in the A and E horizons will be subjected to intense episodes of decomposition. This was the case for Late woodland materials on the fan in Stratum I Block A at Sand Run. Here, evidence in the lower A/upper E horizons was subjected to the highest degree of decomposition on the site. Feature stains were bleached, pottery sherd surfaces were decomposed, and even calcined bones were dissolved. Though strata II and III at Sand Run also contained forest soils, the over-thickening of the A horizon by additions of alluvium/colluvium and organic materials tended to insulate culture evidence from natural decomposition.

The interaction of soil chemistry and preservation may be modelled according to types of landforms. In particular, there is a tendency for pH values to increase moving downward in alluvial/colluvial fan deposits. This was evident in the Michaels Creek fan (Bettis and Hoyer 1983) and in the fans at Napoleon Hollow (Styles 1985:125). In fans the pH values increase from acidic to basic as the depletion of calcite decreases in lower levels, therefore the conditions for bone and shell preservation are better in lower levels of fans. The data from Michaels Creek and Napoleon Hollow also indicate the pH of river alluvium, which contains primary carbonates, is approximately neutral (ca. 7.). This pH level is conducive for preservation of bone and shell. Both trends are evident at Sand Run, as bone preservation increased toward the bottom of the fan (e.g. Block B; Table 7.1) and the terrace (e.g. Block C; Table 7.1). The simplest model of preservation from this evidence would be that sediments of overbank alluvium are more conducive to preservation of organic remains than alluvial/colluvial sediments from the valley walls. High rates of sedimentation, and therefore more rapid site burial, probably increase preservation potentials in both sedimentary environments.

The other issue to be investigated by modelling is where sites are likely to be found in the landscapes of the Mississippi River valley. Others have approached this problem through pool-wide archaeological/geomorphological surveys (cf. Church n.d.; Barnhardt et al. 1983; Boszhardt and Overstreet 1983; Overstreet 1984a). In general, researchers identify morphostratigraphic units and relate the units to time and major geological events in the fluvial system. The result for the Upper Mississippi Basin has been delineation of Late Wisconsinan terraces and alluvial fills, alluvial fans and colluvial slopes, a massive Holocene alluvial fill that dominates the floodplain, and a surficial layer of post-settlement alluvium. The Holocene alluvium presents the most formidable challenge because of its massive volume and structural complexity. Thus far the Holocene alluvium has been studied only in terms of its surface geomorphic features and how it interfaces with earlier and later fills (cf. Church n.d.). This approach has limited utility for prediction of site potentials because available data does not permit temporal divisions within the massive Holocene fill.

Because there are soils, both surface and buried, in the Holocene alluvium, we might cogently inquire why soils have not been investigated as stratigraphic markers within alluvial sediments. Elsewhere, soils have been employed as indicators of relative age and rates of sedimentation: in alluvial fans (Hoyer 1980; Styles 1985), in Des Moines River fans and terraces (Bettis and Hoyer 1986), and in the Middle Mississippi River floodplain (White in Hannus 1983). The three major soils at 13LA38 span the alluvial/colluvial sediments in the bluff footslope and the river alluvium adjacent to Sand Run Slough (see Chapter 11). Inclusion of diagnostic cultural materials demonstrate that the soils mark the same passages of time on both landforms. A similar

relationship between a three-part soil sequence and time was described in the Michaels Creek fan about 5mi north of Sand Run. Here, the first buried soil (2Ab) contained Weaver and Black Sand ceramics, and another buried soil (with an aceramic component?) existed below it (Bettis and Moyer 1983). An alluvial fan at Fort Madison, Iowa (40mi south of Sand Run) also contained a well expressed surface soil and a buried soil above a radiocarbon date of 3650±160 B.P. (Beta-15074; Stanley 1986). These correspondences between periods of pedogenesis, sediment stratigraphy and cultural inclusions have a distribution in the Three Rivers region that is too broad to ignore. Presumably, this sequence of soils, fans and terraces represents the Late Holocene stratigraphic record for this region of the Mississippi valley.

Fluvial systems develop through interrelated responses to climate, time and materials (i.e. complex response; Schumm 1977), so the Late Holocene stratigraphic sequence at Sand Run should correspond to other soils and fluvial stratigraphy in the Midwest. The morpho- and pedogenic stratigraphies from other regions will not necessarily be the same, but the same natural processes that act on the Mississippi fluvial system will impact on cultural evidence in similar patterns throughout that fluvial system. Thus, it is observed that Early Woodland and early Late Woodland remains were discovered in the first buried soil at the Mill Pond site (47Cr186) at Prairie du Chien, Wisconsin (Theler 1983, 1986). Had there been slower sedimentation at Mill Pond, the upper component would have intruded more into the Early Woodland component--precisely the relationship of the Weaver and Black Sand components in Stratum II Block C at Sand Run.

Perhaps there is a typical stratigraphic relationship between Woodland components in the Upper Mississippi basin because a major episode of pedogenesis occurred between ca. 800 B.C. and A.D. 300 (the Sub-Atlantic climatic episode, cf. Wendland 1978). In this scenario the Early Woodland materials were deposited first in the midst of a period of slowed sedimentation rates and pedogenesis. As sedimentation rates slowed more and pedogenesis continued, subsequent intensive occupations at the same site by later Woodland groups would have resulted in the intrusion of these components into the Early Woodland level. The product of these natural processes would have been kitchen middens of the kind that Fowler (1955) and Griffin (1952) used to seriate woodland ceramics into cultural sequences for the middle Illinois River valley.

Cultural interpretations do flow easily, and subconsciously, from perceptions about archaeological deposits. For instance, the weaver tradition of the early Late Woodland period is widely perceived by archaeologists to have developed gradually out of the Middle Woodland Havana tradition. But, this is exactly the view we should expect from the soil stratigraphy just described: i.e. that weaver was deposited in the upper solum, and its pits intruded into everything beneath it in the same soil (cf. Stratum

II Block B at Sand Run), thus mixing and generalizing the cultural stratigraphy. Where a soil relationship like this is a regular pattern throughout a large area, only single component sites or remains buried quickly by rapid sedimentation would provide a true picture of the processes of culture change.

The principals of natural stratigraphy also are applicable to the problem of locating Late Archaic components on the floor of the Mississippi River valley. Overstreet (1984a:13) states a familiar fact that Late Archaic sites are deeply buried and difficult to locate in Pool 10 of the upper valley. The same is true for the locality around Sand Run and Michaels Creek, where the Late Archaic was located 1.2-+2m below the surface. However, depth below surface is a relative concept in floodplains due to the process of lateral accretion of sediments. Overstreet focused on the aceramic component in sandy sediments beneath the buried soil at Mill Pond (Theler 1983) as a representative example of the stratigraphic context for Late Archaic materials in the floodplain. At Sand Run and Michaels Creek the Archaic components were beneath the major soil bearing the woodland components. Likewise, in the central Des Moines valley, late Middle and Late Archaic components occurred in the sandy deposits beneath major soils in Holocene terraces (Benn 1986). To be consistent with the stratigraphic model created for woodland materials (above), we must anticipate that (post-5000 B.P.) Archaic deposits will occur in the bottom or beneath the major buried soil(s) in the Mississippi floodplain. The major buried soils tend to be accessible for excavation (in the upper half of each pool), so Archaic components probably will occur near or below the average water table level. In alluvial fans the Late Archaic components are anticipated in the mid-stratigraphy position below the major upper (surface) soil(s).

### Culture Patterns

The following discussion is sub-divided into three culture periods represented by the strata at Sand Run.

#### Late Archaic Period

Restrictions in the archaeological data from Iowa impede speculative interpretation about this period. Excavated sites are few and widely scattered throughout the state, and their point assemblages do not match. The remains at Sand Run cover only the initial one-quarter of the period, ca. 4500-4000 B.P. Late Archaic records up-river from Sand Run are just as poor, with the majority of the remains assumed to be buried beneath floodplain alluvium or under colluvial slopes (cf. Overstreet 1984b:147).

There are at least four "complexes" of hafted bifaces (i.e. bifacial knives and projectile points) recognizable in eastern

Iowa. One group evidenced conspicuously at Sand Run and in many surface collections encompasses deeply side notched points with squared basal ears and straight or concave bases. These are usually large parallel-sided points, although often heavily resharpened, called Osceola and Raddatz (Morrow 1984:56, 59). A second group of medium sized points with ovate blades have smaller side notches, straight bases, less basal thinning and go by the names Matanzas (Morrow 1984:65) and Godar (Cook 1976). The third complex has more tool types and includes "diggers" and gouges as well as biface types: Wadlow, Karnak, Sedalia, Etle and Nebo Hill (Morrow 1984:16-20, 47). The fourth complex includes small-medium sized points with broad side notches or "constrictions" (e.g. Fort Dodge and Conrad point types; Morrow 1984:63-64) and stemmed points like Table Rock and Durst Stemmed (Morrow 1984:45). Nothing substantive is known about the regional distributions of the four "complexes" or even if these point types comprised distinct assemblages with other artifact types.

There is some evidence of temporal variations among the point complexes. This leads to speculations about possible connections to cultural phases already named in Illinois. For instance, the Osceola points at Sand Run were contemporary with other midwestern Osceola material (cf. Overstreet 1984b), and with Conrad's (1981) Hemphill phase in west-central Illinois and the Falling Springs phase in the American Bottoms (McElrath et al. 1984:36-40). Conrad places the Hemphill phase (ca. 4950-4250 B.P.) between the Helton and Titterington phases of the Lower Illinois River valley (Ibid.). The second complex of Matanzas and Godar points matches the Helton phase (ca. 5500-5000 B.P.), a late Middle Archaic manifestation in the lower Illinois River valley (Cook 1976:107). The third complex is represented by the Sedalia complex in northeastern Missouri (Chapman 1975:203) and the Titterington phase (ca. 4200-3800 B.P.) in the lower Illinois River valley (Cook 1976). My fourth complex may have post-dated Titterington/Sedalia. Two thermoluminescence dates on rock associated with Table Rock Stemmed points from 13WS65 are 2995±330 B.P. and 3633±360 B.P. (Lensink ed. 1986:198), and a radiocarbon date of 3015±65 B.P. (Wis-905) was associated with three Conrad points in 13PK149 at Saylorville Reservoir (Osborn and Gradwohl 1981:131).

This rough chronology implies considerable complexity for the Archaic periods after ca. 5500 B.P. Growing complexity is what researchers have been writing recently about the Archaic periods (cf. Brown and Vierra 1983). Those working in the American Bottom remark about a population influx (increase?), dense artifact middens with pits, and village partitioning in Late Archaic sites (McElrath et al. 1984). At the Koster site the Horizon 6 and 4 middens were prolific and reflected base camp occupations (Cook 1976; Brown and Vierra 1983). Also at Koster and other Late Archaic sites, like the Osceola site (Overstreet 1984b), there are artifacts and raw materials portending social-value: decorated pins, bannerstones, plummet, copper,



red pigments, galena, exotic cherts. Settlement patterns included permanently occupied base camps as well as resource extractive stations, and by the Late Archaic period the valleys and the uplands were extensively occupied (Cook 1976:118; O'Brien 1980:119; Emerson and McElrath 1983:231; Lewis 1983:108; Benn and Rogers 1985:33). Burial ceremonialism had become elaborated to indicate corporate ritual and organization associated with productive members of society (Charles and Buikstra 1983).

The evidence is still too scanty to tell where and when social complexity began to happen among Archaic peoples in eastern Iowa. The material remains of complexity are certainly evident after ca. 4500 B.P. at Sand Run, a year-round base camp with evidence for the native seed complex, bannerstones, galena and red pigment (hematite). This pattern is widespread locally. According to collectors, other sites on the upland salient between the Iowa and Mississippi Rivers yield bannerstones, hematite and other lithics like Sand Run. South of Sand Run and in interior southern Iowa collectors obtain the same kinds of elaborate ground stone and hematite. The Ryan (Red Ochre) complex of the Mississippi Valley in northeastern Iowa may be a Late Archaic burial manifestation (Logan 1976). The artifactual symbols of complexity are not evident, however, as far west as the central Des Moines River valley.

Many of the artifacts of Late Archaic period also were part of the Middle Woodland period assemblage. At Sand Run continuity between these periods is evidenced by blade production as part of a lithic industry that emphasized hard- and soft-hammer techniques. Likewise, the natural subsistence base and native seed complex was common to both periods. The exchange of exotic materials began during the Late Archaic and intensified during the Middle Woodland period. In tracing these continuities, it is evident that the processes leading to complex societies had their origins during the Archaic periods.

Elaborate artifacts and exotic raw materials are symbols of complexity for a common reason; i.e. they represent economic processes in which labor was expended for social purposes other than the simple use-value of the objects. Part of the labor that produced utilitarian objects like ground stone axes and bannerstones, tools of exotic materials and horticultural products was an investment anticipating a future return. Invested labor is "social-labor," i.e. labor-value that is accumulated ("surplus") to fulfill obligations and to pay social "debts" (Bender 1985b). This was the process of socio-economic evolution in hunting and gathering economies that happened during the latter half of the Archaic periods.

Price and Brown (1985:8) propose three conditions that fostered the development of complexity. 1) Social circumscription is the situation where productive units are too packed in territories to allow for emigration to avoid socio-economic problems. 2) Abundant resources allowed for

creation of annual surpluses. 3) Increasing population placed stress on subsistence strategies based on natural resources. Brown (1985:223) argues that exchange of valued commodities began the process of mitigating crowding during the Late Archaic period. I would extend Brown's reasoning by recognizing that the substantial labor investment in elaborate ground stone objects and chipped stone bifaces of quarried cherts would have been an important source of surplus-value for the Late Archaic exchange system. Indeed, one could argue that surplus-value in utilitarian items like axes and bifaces might have been the progeniture of commodities such as copper, hematite, galena and fine cherts.

#### Early and Middle Woodland Periods

These periods of occupation are mixed in Stratum II at Sand Run. Since the large majority of remains in Stratum II belong to the Middle woodland period, no definitive Early woodland period assemblage can be recognized. Interpretations will only be made from typological evidence, virtually all of which has been covered in the ceramics chapter (III) in this volume.

Along the 15mi stretch of bluffline in the vicinity of Sand Run there are 16 sites that have yielded Early Woodland Ceramics (Figure B.1). Most of these sites have other major Woodland components, so the pattern of site distributions has no other significance except collector bias. Five of the sites along Lake Odessa, including Sand Run Slough West, and the Smith site have Marion Thick ceramics. Almost all of the 16 sites have Liverpool ware as well. This is a fairly dense site pattern--probably as dense as anything along the Illinois River or farther south on the Mississippi River. The age of the Marion components is unknown, but it is assumed to have preceeded Black Sand. At Sand Run the stratigraphy appears to indicate that the Black Sand component(s) was contemporary with some of the Havana components, probably the earlier ones (e.g. Late Morton/Caldwell phase, ca. 250-150 B.C. and perhaps the Fulton phase, ca. 150 B.C.-A.D. 1). This overlap of materials from these phases lends support to Munson's (1982) model of a Black Sand tradition separate from the Havana tradition. No overlap of these traditions is recognized to the north in the Quad-States region, but a possible dichotomous settlement pattern in the central Des Moines River valley may be indicative of overlap between local phases (Benn and Rogers 1985).

A troublesome aspect of the Sand Run assemblage is that it did not include stemmed points of the Dickson-Beiknap-waubesa contracting stem and Kramer square stem styles. Neither did the sites with Early woodland ceramics at nearby Michaels Creek have many of these points (Fokken and Finn 1984). Stemmed point styles are widely associated with Early woodland ceramics in Illinois sites (cf. Farnsworth and Emerson eds. 1986). Straight and contracting stem points are well represented throughout

eastern Iowa (cf. Logan 1976:113; Benn and Rogers 1985:Appendix A) and in private collections from sites along Lake Odessa. Kramer points were found with non-Marion ceramics (Middle woodland) that dated by thermoluminescence at A.D. 70 $\pm$ 230 (1880 B.P.; Alpha-807) at Sid's site on the North Skunk River in interior Iowa (Benn 1984a). This failure to associate point styles with a ceramic ware and other artifact types in a recognizable cultural assemblage recalls comments made by two authors in the Early Woodland volume. Griffin (1986:617-618) remarks that projectile point types like Kramer seem to have spread irrespective of the fabric impressed ceramic complex (i.e. Marion Thick) north of St. Louis. James Brown's (1986:607) critique of Munson's conception of Black Sand is that the tradition "...does not seem to retain material integrity over the Midwest."

Brown's assessment of the Black Sand tradition is a small part of his examination of the concept, Early Woodland period. He points out that period systematics (viz. Willey and Phillips 1958) incorporate culture content and time. In Iowa when researchers rely solely on ceramic types the indicator of a culture period (e.g. Tiffany 1986), they are abrogating interpretation of local cultural variability. Perhaps the Early Woodland period never happened on the western Prairie Peninsula (cf. Gibbon 1986; Michlovic 1986). True, a Liverpool phase (Munson 1986:296) existed at Sand Run, and there was a Prairie phase in the Quad-States region (Stoltman 1986), a McBride phase in the central Des Moines valley (Benn and Rogers 1985) and a Crawford phase in western Iowa (Benn 1983). It is a serious issue, however, whether these phases were part of a chronological stage of development (and therefore a period) or merely transitional phases of either Archaic or Woodland periods.

The Middle woodland period presents no questions of taxonomy, only problems of classifying local cultural variants that resided on the prairies west of the Illinois River valley. The Middle Woodland assemblage from Sand Run contains traits in ceramics, chipped stone and Hopewell cult objects that make it part of the Havana tradition, probably belonging to the seven phases (Marion through weaver) of the central Illinois Valley. That exactly seven phases are represented at Sand Run is problematical, owing to mixing in the Stratum II midden. A chronological range is present: Marion and Morton (early), Hopewell and Naples (middle), Baehr and weaver (late).

Zonal styles of the Havana ceramic tradition have been developed for Illinois (Struever 1965; Loy 1968) but not for all of the Upper Mississippi River basin. Bailey (1977:30) names the Bennett-Roth zone for the north-central Mississippi Valley, presumably what is called the Three Rivers region herein. Havana pottery in this zone has a high proportion of dentate stamps on the upper rim and few rims of the type, Steuben Punctate. This terse description fits with the Sand Run collection, but there are too few studies of Havana ceramics in this part of the

Mississippi basin to know if the Bennett-Roth style zone is authentic. Logan (1976:177) divides the Middle woodland manifestations in eastern Iowa at Jackson County (i.e. the northern border of the Three River region). Other style zones probably exist to the west and north. In the Quad-States region the concentration of middle Havana types--Naples and Havana Zoned--the relative absence of earlier types, and the replacement of Baehr by Linn ware indicates a separate zone. The large valleys of interior eastern Iowa also may harbor another style zone of Havana (Amana Havana?), or perhaps a different Middle woodland tradition. The Havana tradition cannot be defined beyond these areas in the Upper Mississippi basin and in central Iowa.

Another important manifestation of the Havana assemblage is lithics. Chipped stone styles like corner notching, broad flat flaking and blade manufacture are key traits of this period. Another is the preferential use of exotic cherts and heating treating on blades and chipped stone. At Sand Run about 90% of the chipped stone debris is made of local Burlington cherts. However, a high proportion of the blades and finished chipped stone tools are made of cherts from more distant sources. This pattern of chert utilization is what Struever (1973) described for the Lower Illinois Valley, what Cook and Koski (1985) found at the Massey and Archie sites, and what Stafford (1985) found at the Smiling Dan site. Heat annealing of local cherts also substituted for the use of high quality exotic cherts in the making of blades and chipped stone tools. At Sand Run the major imported chert was Warsaw Tabular (Morrow 1984), a lenticular chert that occurs in bands thin enough to be chipped into stone tools but too thin to be made into cores. Manker and Snyders-like points found across eastern Iowa are often made from Warsaw Tabular. Other exotic materials from Sand Run--knife River and Cobden cherts, specular hematite and galena--are products of the pan-continental exchange system. The hematite could have come from across the river near Hardin, Illinois (Seeman 1979:294), and it also occurs in pebble form in southern Iowa and in the Late Wisconsinan glacial tills of central Iowa.

The parameters of the subsistence base and settlement type at Sand Run fit models developed in Illinois. Subsistence at Sand Run was based on fish, white-tailed deer, nuts and a horticultural complex of mostly native cultigens. Features yielded a ubiquitous pattern of these resources that suggests a consistent procurement strategy year after year (cf. Stafford and Sant 1985:433). The horticultural plant complex of chenopod, little barley, maygrass, erect knotweed, squash and possibly panic grass and marsh elder was established and, furthermore, lacked maize (cf. Asch, Farnsworth and Asch 1979; D. Asch and N. Asch 1985a:202; 1985b). Sand Run looks much like a "base settlement" in Struever's terminology (1968): a permanently occupied site on a backwater channel that yielded a wide range of task activities. Only the summer season (July-September) is

poorly represented in that there are no remains of fleshy fruits and a low incidence of this "season" in fish annuli.

Struever's model of settlement types (1968) could be applicable to the Sand Run locality if more research were available. Middle woodland sites in the Sand Run vicinity are depicted in Figure 8.2. There is survey bias in this meager number of 17 sites, but important variability in site types is evident. First, there are at three major base settlements with associated burial mounds (13LA12, -29, 104). Toolesboro (13LA29) has a group of huge mounds that yielded quantities of Hopewell interaction items. Seaman (1979) identifies Toolesboro as a "type-three" site in the interaction system. Site 13LA104 on a large fan has not been investigated, but there appears to be a mound on the village and a mound group on the bluff above the site. Site 13LA12 is the Gast Farm, a location that has yielded quantities of exotic artifacts like platform pipes. There is an enclosure on the bluff above Gast Farm and a mound on the village site. Either or both the Gast Farm and Toolesboro might qualify as a "regional exchange center" in Struever's system. Second, the other sites that produced Havana ceramics tend to be smaller and do not have clearly associated mound groups, although mounds may occur nearby. These are base settlements in the case of Sand Run or seasonal procurement stations and mortuary camps in the cases of upland sites.

The settlement pattern of large Havana villages and Hopewell mounds extends over the whole Three Rivers region--Burlington, Muscatine, Davenport/Moline, Clinton. The distribution is most apparent in the results of nineteenth century mound excavations by the Davenport Academy of Sciences (e.g. Tiffany 1876, Lindley 1876; Farquaharson 1876; Pratt 1876; Starr 1897), and it can be inferred from collector information. There are major Havana-Hopewell village/mound complexes south of the Iowa River mouth at Kingston and Burlington. The village at the Albany Mounds probably was a regional exchange center because quantities of interaction items come from its trash pits (Bud Hansen, personal communication). The Havana-Hopewell settlement pattern extends farther up-river, because of the Nickerson focus in northwest Illinois (Bennett 1945) and the Trempealeau site at LaCrosse, Wisconsin (McKern 1931). However, there are no spectacular mound groups that would suggest an intensive Hopewellian manifestation in northeastern Iowa (Logan 1976).

It seems pertinent to inquire why the Havana-Hopewell system was intensified in its "classic" form on the Upper Mississippi River in marked contrast to interior Iowa. There are two major environmental advantages in the Mississippi Valley. It was a major trade route to the copper resources of the north and to knife flint and obsidian of the northern Plains. Additionally, the Mississippi is a huge biosystem with prolific backwater channels for intensive collecting of aquatic resources. However, environmental advantages do not explain socio-economic prerogatives of human beings.

Struever (1968) was the first person to treat the Hopewell interaction system as a economic problem. The picture of Middle Woodland society that emerged from the Hopewell Archaeology volume (Brose and Greber 1979; cf. Hall 1980) was of corporate descent groups who intensively exploited natural resources. Corporate "rights" to the products of the natural system were legitimated by rituals of the Hopewell Burial Cult and were propagated and reinforced through participation in the pan-regional interaction system. Current thinking about social stratification in the Havana-Hopewell system is that a plurality of levels existed, with status being achieved through manipulation of the exchange and lineage systems (cf. Seaman 1979:411; Brown 1979; Braun 1981; Bender 1985b:47; Stafford and Sant 1985:455; Charles, Buikstra and Konigsberg 1986:459). Authors generally equate the most intensive Hopewell production systems with the most elaborate earthworks and mortuary associations in southern Ohio (cf. Seaman 1979). Therefore, the overall picture of the pan-continental Hopewell system is of "centers" of intensive development integrated with regional centers, and the whole surrounded by a periphery of peoples "copying" elements of the cult system.

Despite the sophistication of recent analyses of the social organization at Hopewell "centers," this model of cultural interaction does not explain participation of people on the "periphery," nor does it deal with changes in the system. This is an analytical problem for archaeologists: i.e. finding a basis for comparing all Hopewellian manifestations.

I prefer to analyze cultural systems according to how value is produced from the environment (cf. Wolf 1982). "Value" is natural resources that are transformed into products by human labor. In human economies the environment can be both an object of production, as when resources are merely extracted, and an instrument of production when the environment is modified as a tool of production (e.g. cultivation). In kin-based economies, the products of an individual's labor are shared with the corporate group (i.e. social-labor), and rights and obligations to social-labor are passed through generations of family members by application of rites of passage.

Two relationships between human labor and resources in the Middle Woodland systems are fundamental. First, the environment was treated as an object and an instrument of production. As an object, it was seasonally exploited by applying collecting methods to patches of the dense resources (Caldwell's Primary Forest Efficiency). As an instrument, parts of the environment were cultivated to yield an array of mostly native cultigens. Natural patches probably were "weeded" to encourage desirable species as well. Both treatments of the environment involved labor-intensive methods, with labor being contributed to a communal system of delay-return (more so for the cultivation complex). The second aspect is the presence of surplus production (cf. Bender 1985:210). Surplus is created when social

significance is added to the simple use-value of materials because they are exchanged for obligations ("debts"). Notice that surpluses are produced by social-labor under the direction of authority. The obvious material surpluses in the Hopewellian system were raw materials and objects of the interaction system and the mortuary/earthwork complex.

In the labor relations described above, Middle Woodland society was reproduced when authorities successfully directed and coordinated labor to produce necessary products from specific patches of natural or cultivated resources. In other words, labor allocation and established associations with resource patches were the critical elements. Mortuary rituals established and perpetuated the associations between the productive unit (corporate lineage) and its territory (resource patches), and between the society's leaders and their labor supply (cf. Charles 1985). The Hopewell exchange system was an extension of the local labor relations to other productive units in the sense that procurement of distant resources was another manifestation of the ability of authorities to control labor-value. Exchange of interaction items is the same as exchange of solidified labor-value, in this case surplus labor-value.

Everywhere in the Eastern United States where there is evidence of mound building and surplus production of artifacts during the Middle Woodland period, the labor-resource relation I have described must have existed. This arrangement of social-labor was made necessary by an historical process Bender (1985a:56) and others call "closure." Closure is the perception of packing among autonomous productive units; it means as packing increases, productive units must define themselves in relation to their future access to resources and to surrounding units. Closure became a significant factor by the Late Archaic period in the Midwest (cf. Price and Brown 1985). Since closure is a perception of the labor-resource relationship between potentially competing productive groups, the initial socio-economic responses to a condition of closure would have reverberated beyond the limits of the "packed" area--i.e. across the Prairie Peninsula in Iowa and Missouri.

The historical process called "Hopewell" involved a pan-regional stimulation of kin-based authorities to establish control of surplus labor-value. The stimulation for this process extended as far as there were human populations dense enough to appropriate value from surplus labor. The artifacts and styles of Hopewell were derived from ancient mythology and environmental relationships (Hall 1979) and were diffused by the managers of surplus-value.

Development of regional variants of Hopewell was an historical process affected by local conditions, most of which are not defined by researchers. In the Midwest, especially southern Ohio, where conditions of closure had existed for a couple of millennia during the Archaic period, the appropriation

of surplus-value had become a traditional aspect of the descent system, and much of a Hopewell manager's status might have been ascribed by birth. Still, the heavy reliance on natural resources would have exerted a strong pull away from ascribed status toward lifetime achievements. This seems to have been the case for the Havana tradition. In the Quad-State region and central Iowa, there is no evidence of closure conditions during the Late Archaic, so the mode of production during the Middle Woodland period was not preceded by a long historical development of the position of surplus manager. The symbolic Hopewell artifacts of a strong manager are fewer in the Quad-State region and virtually lacking in the central Des Moines Valley. However, elaborate mortuaries, large permanent villages and the native horticultural complex--aspects of the Middle Woodland mode of production--are present in both areas. This argument could be advanced for a Middle Woodland period on the eastern Plains (but see Venik 1983).

Because the Hopewell was a particular form of labor appropriation, the evolution of the system tended to be almost synchronous on a pan-regional scale. At its initiation, most archaeologists believe there was a population increase. Increased population probably was a product of managers manipulating a labor-intensive production system to yield more surpluses (cf. Bender 1985a:58). Whether increased population preceded or followed "complexity" (Charles, Buikstra and Konigsberg 1986:472; Griffin 1986:616) probably depended on local conditions. Pan-regionally, the height of the exchange system came between A.D. 100 and 200 (Ibid.), apparently because development of labor controls coincided with the packing of populations across the prairies. This was the time when regional florescences occurred in the Quad-State region, in interior eastern Iowa, in the central Des Moines Valley and in the Kansas City locality.

The demise of the Hopewell system signified changes in the mode of appropriating labor-value (i.e. the mode of production) and the end of the Middle Woodland period. These economic processes are difficult to pinpoint in late Middle Woodland cultures, because some artifacts of the interaction sphere seemed to have persisted in general use (e.g. copper awl, points of Warsaw chert, figurines at Sand Run). The clearest change involved a gradual shift to applying more labor to cultivation, first to the native seed complex and later to maize. Notice that the appropriation of surplus-value did not have to be abandoned in this economic change. Rather, the origin of raw materials shifted in favor of cultigens. The sources of labor-value also changed, since value in horticultural economies is derived solely from the labor of members of the productive unit. In this scenario, surplus-value would have been generated increasingly from the labor in horticulture by the productive unit, which would have made the unit more independent and matrilineal (assuming women did the cultivating).



## Late Woodland Period

Recent interest in this prehistoric period by professional archaeologists has expanded the numbers of cultural issues to be resolved without really settling any important questions for the area of eastern Iowa. South on the Mississippi River in the American Bottom the FAI-270 project (Bareis and Porter eds. 1984) has added depth and dimension to understanding the processes of culture change during the Late Woodland and Emergent Mississippian periods. But, comparison with the American Bottom experiences does not help much to elucidate what came to pass in Iowa, because there was a strong trend toward regionalism during the Late Woodland period. Regional characteristics must be identified, then interrelated as a systematic process across the prairies of Iowa and Illinois.

The Late Woodland period began (ca. A.D. 350) with the widespread manufacture of undecorated or minimally decorated potteries, the dissolution of the Hopewell Interaction Sphere, the fading of the use of sub-mound mortuary crypts, and the abandonment of lithic tool styles characteristic of the Havana tradition. When and where this period began in the Upper Mississippi River basin is open to interpretation based on combinations of material evidence. The ceramic evidence will be considered before other types of information.

The Weaver and Linn potteries developed out of the Havana and Hopewell ceramic industries. Indian experience with the technology of Hopewell ware is particularly evident in the hard pastes, thin walls and smoothed-over (often burnished) surfaces of Weaver and Linn potteries. Tool impressions on the exterior upper rim also are seen as derived from decorations in the same position on Hopewell and Baehr vessels. The stratigraphic evidence from Sand Run (Table 3.15) indicates that the vast majority of Weaver pottery succeeded Baehr and Hopewell pottery. These trends mean that the technology of a specialized ware (Hopewell) was subsequently applied to produce domestic wares (Baehr, then Weaver and Linn). Improvements in ceramic technology, i.e. thinner walls and more shock-resistant pastes, have been related by Braun (1983) to the requirements for simmering hard seed foods. Technical improvements in ceramics are evidenced across the Prairie Peninsula to western Iowa during the early Late Woodland period (Benn 1983; Benn and Rogers 1985:48). The drastic reduction in decoration on Weaver and Spring Hollow vessels undoubtedly related to socio-economic conditions, but it also may have been an outcome of the priority to manufacture stronger vessels.

Surface treatments on pottery of the early Late Woodland period may be an important indicator of regional differentiation. In the Three Rivers region and central Illinois, Weaver ware contains a low proportion of cord roughening up to the lip. In the Sand Run collection there was a clear preference for low relief cord impressions that were mostly obliterated by surface

smoothing. Smoothing often resulted in burnished patches. North in the Quad-States region the surfaces of Linn ware vessels are usually completely plain, although the prolific use of decorative elements in Linn ware takes precedence in the typology. The Lane Farm types are a particularly interesting parallel with Weaver types, since the Lane Farm types have burnished surfaces but substitute rocker stamping for a cord roughened body surface treatment. Moving up the Des Moines River to central Iowa, the proportions of body and rim cord roughening increase. South in the American Bottoms the proportions of cord roughened vessels are very high (Kelly et al. 1984a).

In Iowa it has not been determined that the occurrence of lip/upper rim decorations in Weaver or Weaver-like potteries have cultural or chronological significance. Perhaps the proportions of tool types and decorated/undecorated rims have regional significance. Two phenomena relating to decorations are observed. 1) The type definitions for Spring Hollow Plain and Cordmarked are based on surface treatment, not lip/rim decorations. Therefore, Tiffany's suggestion (made in the format of good Plains ceramic nomenclature; Lensink ed. 1986:243) that a "Spring Hollow Decorated Lip" type be created is premature to considering redefinition of the Spring Hollow assemblage. 2) There is no temporal overlap between Weaver/Linn wares and Minotts potteries, because the corded pottery industry intervened. Small Weaver and Spring Hollow rim sherds often are difficult to distinguish from later plain potteries (e.g. Minotts Plain) unless decorations are present. Tool impressions on the upper rim combined with the thin, round lips on Weaver vessels are distinctive from Minotts Plain, with its smoothed and flattened, often extruded lips and occasional tool notching on the lip. (Without decoration, there may be too few traits on small, plain rims to base a sound typological decision.) Thus, the question of whether to name a type, "Minotts Decorated Lip" (Ibid.), should be a separate typological issue from the Spring Hollow typology (see 1 above).

The initial date of the Late Woodland period is conjectural. The stratigraphy and radiocarbon dates from Sand Run do not contradict the Illinois Valley sequence, so A.D. 350 is taken to be the beginning of this period in the Three Rivers region. In the Quad-States region the earlier types in Linn ware (i.e. Levsen) were manufactured in a Middle Woodland milieu (the Allamakee and Millville phases; Stoltman 1979). However, I place Lane Farm Cord Impressed (CI) later in the Linn ware sequence than Stoltman and associate Lane Farm and perhaps much of Spring Hollow pottery with a post-Hopewellian horizon (Benn 1979:64). A date of A.D. 450 for the beginning of the Late Woodland period is proposed for the Quad-State region. In the central Des Moines River valley the beginning of the period is estimated at A.D. 400 because of fourth century radiocarbon dates from Middle Woodland villages (cf. Benn and Rogers 1985:40-46). These chronometric estimates suggest the Late Woodland period was time-transgressive up the Mississippi valley and west across the prairies of Iowa.

Once, I suggested a "Transition period" be named instead of "early Late Woodland period" for the time when Weaver and Linn wares were made in eastern Iowa (Benn 1980). This new nomenclature was a superfluous addition to an already established Woodland chronology and should be forgotten. But, a reality must be recognized in this notion. It is that during the time of Weaver/Linn manufacture few new traits were added to the assemblage while many Havana-Hopewell traits were abandoned gradually. For instance, Steuben, Weaver and Allamakee components along the Mississippi River seem to yield Hopewell artifacts such as pipes, exotic stone, copper and figurines. This was a true period of transition until the appearance of a new, distinctive ceramic industry, the corded wares.

Recalling the ceramic discussion (Chapter III), five groupings of corded pottery were recognized. Lane Farm CI in the Quad-States region was the earliest, with its classic forms (cf. Logan 1976) having been manufactured between A.D. 450 and 650. In a technical sense, Lane Farm pottery is analogous to Weaver and therefore is not a Weaver successor. Lane Farm is unique in having cord impressed decorations--a new post-Hopewell trait--but the definition of the ware takes precedence over decorative variations (note: Lane Farm Stamped is a companion type). Therefore, Lane Farm CI should not be considered as a corded ware in cultural typologies.

Major culture change and regionalization sought so diligently in potteries of the post-Havana-Hopewell period are apparent in the corded potteries that succeeded Weaver and Linn wares. In the Quad-State region, Madison ware was manufactured by ca. A.D. 650 and probably earlier. Madison Fabric Impressed (Hurley 1975; Benn 1980) was not simply a refined version of Lane Farm CI; it was a new technology. A fabric sheet with raised decorative elements was applied to the vessel surface, sometimes with the fabric selvage being lapped over the lip and onto the interior rim surface. In some instances the connection between paste and fabric was so close that fabrics must have been fired on the vessel. The bodies of Madison vessels were malleated with low-relief cord-wrapped paddle impressions so that the entire exterior surface was roughened.

Along the southern boundary of Driftless Zone (i.e. Quad-States region) Madison ware interfaces with an unnamed corded ware that is found in southeastern Iowa and west-central Illinois. These are the "cordmarked" and "cord-impressed" ceramics with squared and castellated orifices described by Riggle (1981) and Morgan (1986b) and present at Sand Run. Like Madison ware these potteries are covered by low-relief cord roughening and have single cord impressions for rim decorations. Fabrics seem to be present (Riggle 1981; Morgan 1985b), although Madison ware has more complex cords and fewer undecorated vessels. Also different from Madison ware, the walls of larger pots of the unnamed ware are quite thick (ca. 8mm). The unnamed ware is different from Sepo, which occurs in central Illinois and

the southern Upper Mississippi River basin (i.e. Deer Track site; White 1985). It also differs from Loseke ware, which has for its most easterly distribution the central Des Moines River valley (Benn and Rogers 1985). All four of these regional complexes--Madison, Sepo, unnamed (Sand Run), Loseke--were contemporaries for part of the time between ca. A.D. 650 and 800 and probably represented a locus of development for the corded ceramic industry, which eventually spanned the northern United States from the Atlantic seaboard to the eastern Plains (cf. White 1985:39).

The pan-midwestern proliferation of cord decorated wares after A.D. 800 involved the innovation of new rim forms along with the older styles, all of this in many regional variants. The literature authenticating these regional potteries is incomplete and disconnected, but some patterns in and around the Three Rivers region are recognized. East and northeast in Illinois the Maples Mills/Canton complex has complicated cord designs over the plain surfaces of castellated rims (Fowler 1955). This pottery is thought to have been brought into central Illinois later than Sepo (Harn 1975; see White 1985:96). At Sand Run and west in interior eastern Iowa the dominant ceramic complex has the types, Minotts Plain and Cord Impressed (Logan 1976). Besides castellations, the Minotts types show considerable emphasis on smooth-finishing and everting of the lip, and there may be significant variations in the height and curvature (i.e. rim/shoulder angle) of the rim, although the latter traits are not yet analyzed adequately. In northeastern Iowa the Hartley and French Creek wares contain many variations of rim form, thickness and height. In the Red Rock locality of south-central Iowa, Roper (1986:189-190) has found cord decorated collared ceramics like Aztalan Collared but not in any definitive context. Finally, in central Iowa the castellated Saylor ware belonged to the post-A.D. 800 period (Thies 1978; Benn and Rogers 1985), and Loseke ware probably continued to be produced as well.

A more significant pottery that dominated central and northwestern Iowa was made by Great Oasis people (Kenning 1971). Their's was a grit tempered pottery with fine incising rather than cord impressing in parallel and chevron motifs on the rim. Great Oasis ceramics are divided into two wares based on the relative height of the rim.

Aside from regionalism, there is another point to compiling the preceding list of ceramics. It is that rim form assumed greater emphasis in woodland ceramic styles after ca. A.D. 800. By rim form I mean relative height, thickness, lip shape and orientation, and angle above the shoulder. Obviously, body form also relates to some rim attributes. Those who have classified other contemporary potteries, for instance the Cahokia Mississippian pottery (e.g. O'Brien 1972) and Plains Villager ceramics (e.g. Wheeler 1952), recognized the need to use rim form in the definition of wares and types. Midwestern archaeologists

concerned with Late Woodland potteries have so far demonstrated less attention to form.

Rim form, I believe, is a key factor in the recognition of the "Mississippianization" of Late Woodland cultures. Late Woodland pottery with castellated, collared, corded, or plain attributes has turned up with shell tempered Mississippian wares where investigators have searched. For example, the Cook site (Markman 1986) and Rensch site (McConaughy, Jackson and King 1985) in northern Illinois had shell tempered Langford ware associated in pits with grit tempered Woodland wares (collared wares at Cook; Maples Mills variants at Rensch). Tiffany (1982) presents his own version of the Mississippian association by pointing out how similar the Hartley and French Creek potteries from northeastern Iowa are to Mill Creek ceramic wares from northwestern Iowa. Mill Creek people were part of the Plains Village tradition. From interior eastern Iowa the Mouse Hollow Rock Shelter (Logan 1976:81) was the one site that yielded both Ramey Incised and collared ceramics. It also is noteworthy that Minotts and Oneota ceramics have essentially the same form: globular bodies with sharply delineated rims. These are merely a few examples of the congruence of so-called Mississippian and Late Woodland attributes which were products of a broad process of culture change now known as Emergent Mississippian (cf. Kelly et al. 1984b; Markman 1986).

Besides ceramic evidence, technical changes that mark the Late Woodland period are evident in other tools, subsistence and mound building. Changes in these aspects are more difficult to pinpoint because there is less published evidence and fewer diagnostic traits.

Regarding chipped stone, the remains at Sand Run came from midden associations so the Weaver component cannot be considered separately from the Middle Woodland material. The presence of Manker and Marshall point types does suggest that there were Weaver lithics comparable to components from the central Illinois River valley (e.g. Wray and MacNeish 1961). The majority cord impressed pottery in Stratum I is associated with a lithic industry that emphasized small flakes, many of which were retouched to make hafted fabricating tools or triangular projectile points. The same reduction process for points is illustrated in greater detail by Billeck (1986:84) for 13WS61 in the F-S18 corridor west of Sand Run. This was not a new technology for Late Woodland peoples, for the production of blades and other micro-tools was a significant component of Middle Woodland lithic industries. Rather, the emphasis on flake tools is interpreted as a trend toward an expedient technology. The change entailed a profound shift in the proportions of different tool types (e.g. arrow points, hafted flake tools), the over-all production of smaller flakes and retouching by pressure techniques, and the use of stream cobble chert. Like the appearance of corded ceramics, the shift to smaller (arrow) projectiles was a pan-midwestern phenomenon (cf. Hall 1980).

The Stratum I lithic assemblage at Sand Run has few cobble and ground stone tools and a very high proportion of cherts derived from local sources. The use of few ground stone tools means that relatively little labor was expended on this tool category--a significant factor when compared with the larger amount of labor that must have been supplied to manufacture grooved axes, plummets and bannerstones during the Late Archaic period. The same labor formula can be applied to the fashioning of expedient flake tools and to the procurement of local cherts at Sand Run. Similar patterns of ground stone production and lithic procurement have been observed at other Late Woodland sites (e.g. American Bottoms in Kelly et. al. 1984a,b; Deer Track in McGimsey 1985; the F-518 project in Lensink ed. 1986).

I have posited a labor relation for lithics because this is a theme that links all kinds of tools with other socio-economic aspects of culture. Recall the labor relationship inherent in David Braun's (1983) contention that stronger, thinner-walled Late Woodland pots made extraction of nutrition from hard seeds more effective.

The horticultural plant complex that necessitated better pots became a widespread part Middle Woodland subsistence (cf. N. Asch and D. Asch 1985), and substantial labor inputs were necessary to sustain and expand this horticultural complex throughout the Late Woodland period. The labor-intensive crop added after ca. A.D. 600 was maize (op. cit.:196; D. Asch and N. Asch 1985:92; Bareis and Porter eds. 1984). The Aschs' review of recent evidence indicates maize production increased in importance between A.D. 600 and 800. This is consistent with the quantities of maize kernels from the pre-A.D. 800 components at Hadfields Cave in eastern Iowa (Benn 1980) and from the Brogley rock shelter in southwestern Wisconsin (Tiffany 1974). Maize cupules also have been recovered from an Allamakee phase context at the FID site, northeastern Iowa (Benn 1979:66). The FID samples came from levels with Lane Farm CI pottery, thus the association between maize cultivation and cord decorated pottery probably is appropos for the Upper Mississippi River basin.

Another labor relation is the one that produced earthen mounds. In eastern Iowa the internal mound structure changed during the Late Woodland period. Sub-floor tombs and grave goods from an interaction system were discontinued and replaced by more variable arrangements of pits, bundled bones, rock features, isolated artifacts and pottery, and mounds in effigy forms (cf. Orr n.d. Logan 1976:157-164; Mallam 1976; Benn, Mallam and Bettis 1978). Furthermore, mound building by Woodlanders seems to have waned by ca. A.D. 1000, for there are no examples of Minotts pottery from mounds. There are examples of Oneota burials and ceramics from Iowa mounds (e.g. Logan 1976:164; Benn and Bettis 1977). Perhaps, these represent usurping of Woodland ideology by the dominant Oneota--the culmination of socio-economic change I will describe shortly. In general, what is seen in Late Woodland mound building in the Upper Mississippi

Basin is an emphasis on community symbols (cf. Mallam 1976; Hall 1980): e.g. effigy mounds, domestic tools, empty (processing?) features, burned rocks, ashes, clam shells, manipulation of sod and mound fills, occasional inclusion of heirlooms, and burial of disarticulated human skeletal elements.

If mound building is closely related to communities and their symboling, what of the changes in community structure and settlement patterns during the Late Woodland period? This information is impossible to come by in definitive amounts. Along the 15mi stretch of bluffline around Sand Run there is a continuous array of Woodland mounds, most of the 32 groups probably being or having some Late Woodland aged structures (Figure 8.3). There are only 18 habitation sites with Late Woodland pottery in this stretch of river. Clearly, habitation sites are underrepresented probably for geomorphological reasons. The blufftop road survey and testing projects (Fokken and Finn 1984; Fokken and Marcucci 1984) show that the known sites were base camps or temporary camp/procurement stations. The Sand Run Stratum I component was a base camp. The same types of habitation sites seem to occur like the Middle Woodland pattern, but Late Woodland sites are more dense. In Illinois the pattern was a smaller community size (cf. Kelly et al. 1984a; McConnaughy, Jackson and King 1985; Markman 1986) and dispersion of Late Woodland sites over a wider range of environments (cf. Benchley, Hassen and Billeck 1979:158; N. Asch and D. Asch 1985:103). These patterns are consistent with the limited data from eastern (Lensink ed. 1986), northeastern (Mallam 1976) and central Iowa (Benn and Rogers 1985:47-57). Compared with the Middle Woodland pattern, the Late Woodland pattern is interpreted as evidence for the fissioning of the basic productive units of society.

The fissioning and dispersal of smaller-sized productive units is consistent with observations made earlier about tools, resources and labor investments. Small, autonomous productive units would have utilized local resources and exploited maize/native seed horticulture effectively. Lone hunters could have taken deer efficiently with the bow and arrow. The additional labor time needed for these endeavors would have been compensated by a reduction in efforts relating to the procurement, production and redistribution of materials associated with the system of burial cults and an interaction system of the previous period. However, the compensation between labor processes during periods of culture change is a process to be observed but does not provide an explanation for the change. Explanation resides with the corporate structure of kin-based social formations and why it changed.

The corporate descent groups of the Middle Woodland period were collecting natural resources, and they were transforming part of the environment through simple horticulture. These are two labor processes: the former uses the environment as an object of social labor; the latter uses the environment as an

instrument of social labor (cf. Marx in Wolf 1982:91-92). The Late Woodland period commenced when people began using the environment more as an instrument of production and less as a source for natural resources. There is no precise time when this transformation occurred, since the processes of change came as a feedback cycle. Barbara Bender (1985a:56) recognizes the period of change as the time when "social closure" (i.e. the perception of "crowding") impinged on the ability of producers to settle debts in exchange systems. For people of the late Middle Woodland period the economic transformation involved breaking out of traditional subsistence patterns which connected a corporate labor control system to patches of dense natural resources. Many kin groups must have abandoned familiar patches of natural resources to exploit the same resources in smaller, interior valleys, and many kin groups in all kinds of territories must have intensified their horticultural production by supplementing with maize. The size and territorial needs of the corporate productive unit decreased because of fissioning and because adequate production could be obtained from improvements in the instrument of production (i.e. a horticultural environment).

With modifications in the labor processes there were substantive changes in integration systems that related Late Woodland descent groups. The evidence for close interaction among Late Woodlanders is seen in common motifs in ceramic designs. In eastern Iowa there are numerous mound groups that attest to periodic congregations of production units (Mallam 1976). This appears to have been peaceable interaction--human bones with arrow wounds are very rare--which maintained a dispersed population in family territories. That interaction was more often coercive to the southeast in Illinois is probable, since mounds in the southern Illinois Valley have yielded a number of arrow-inflicted wounds in human burials.

The appearance of the Oneota in northeastern Iowa by A.D. 1000 indicates that processes were operating much earlier to intensify the interaction system around two aspects: centralization of authority and control of labor supplies (cf. Benn 1984b). Both aspects are theoretically anticipated to have occurred as part of Late Woodland production system. The only way to increase production in a kin-based, horticultural economy, barring introduction of new crops and technology, is to increase labor investment. This was accomplished by extending kin-based authority to control the labor of non-kin (i.e. politics) and by intensifying symbols and rituals that emphasized the leaders' monopoly over the control of production. The process of politicizing kin-based authority lies at the heart of "tribalization," an organizational level that typified aboriginal groups of the Historic period. The intensification of symbols and rituals to promote control of production is a process associated with the loose term, "mississippianization," in the Midwest. The concept of mississippianization is not employed here to mean diffusion of traits from a "center," i.e. Cahokia, for as Markman (1986) correctly points out, changes resulting in



the florescence at Cahokia were pan-regional in scope and occurred earlier on some parts of the Prairie Peninsula than at Cahokia.

The era of the Oneota in the Sand Run locality is barely evidenced by a single body sherd from the surface of the site. Sand Run Slough is the type of floodplain location not favored by the Oneota for their large, permanent villages. However, the banks and levees of Mississippi River sloughs were visited seasonally by Oneota (the evidence is turning up in the 1987 Pools 17-18 survey for the COE) probably in the course of their hunting and gathering activities. Even this kind of minimal evidence of Oneota presence should have political implications because of the manner in which the Oneota political-economic system was designed to attract and control large supplies of labor. By concentrating population in large villages surrounded by expansive hunting and gathering territories (cf. Benn 1984b), the Oneota affected the archaeological visibility of their settlement system. Those large villages are very prominent to archaeologists and artifact collectors, but small resource procurement stations and camps are almost invisible--like the Oneota component at Sand Run.

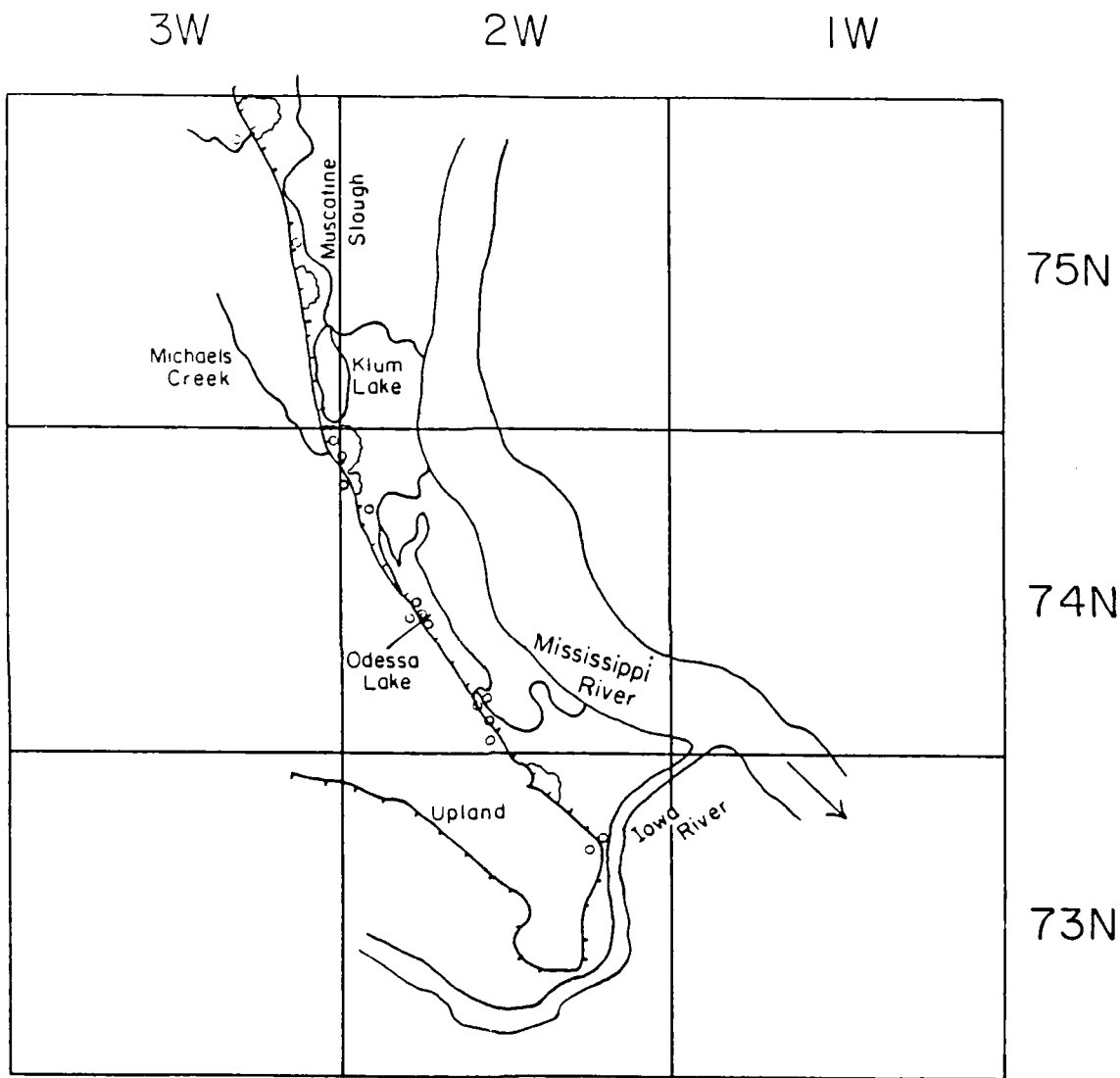

Figure 8.1  
 Early Woodland Period  
 ◦ Sites with Pottery\*

Bluff  
 Fan



\* Information from published reports and State collections

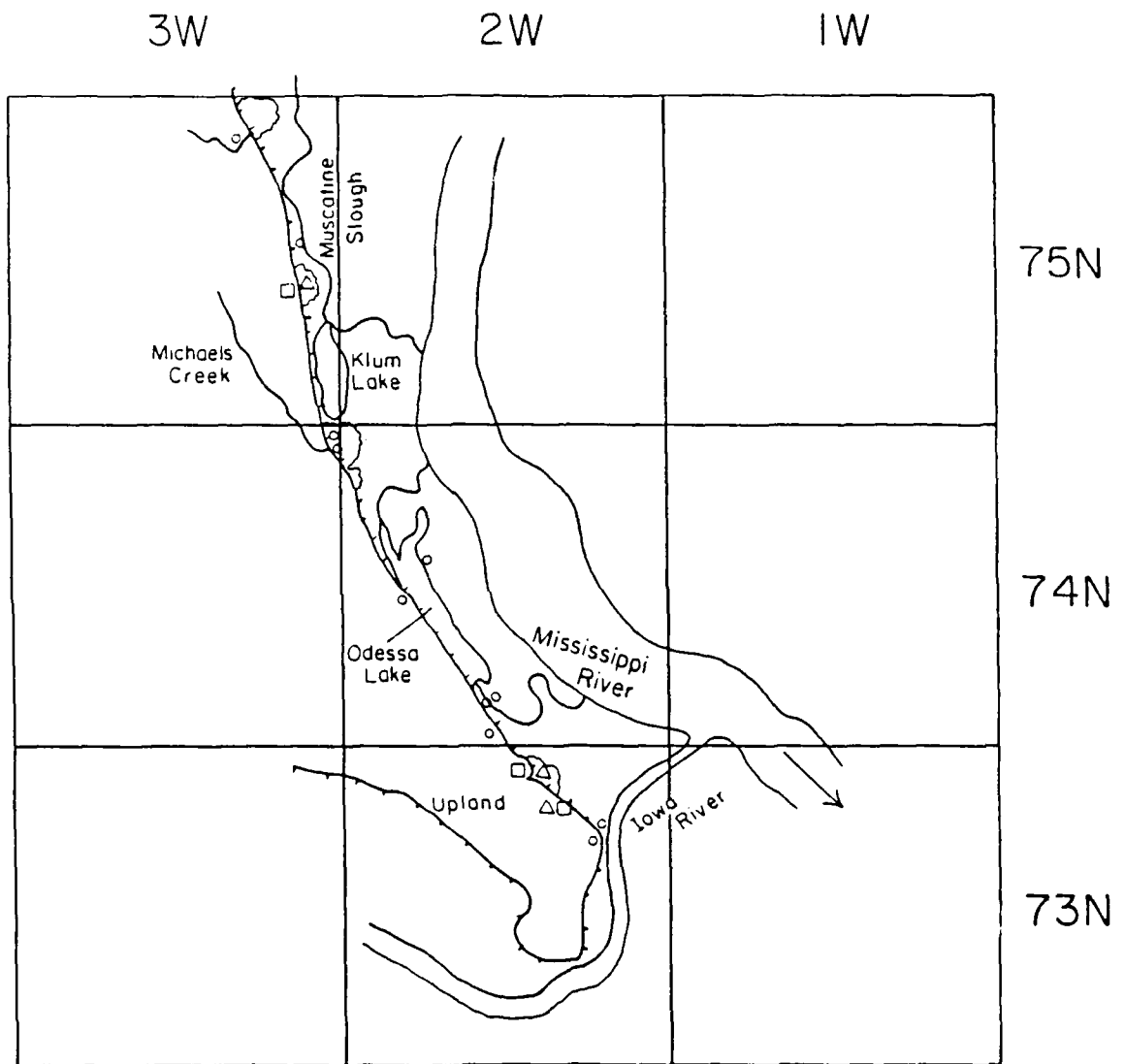

Figure 8.2  
 Middle Woodland Period  
 △ Major Villages  
 □ Major Mounds  
 ○ Sites with Pottery

Bluff

Fan

0 3  
 MI

N

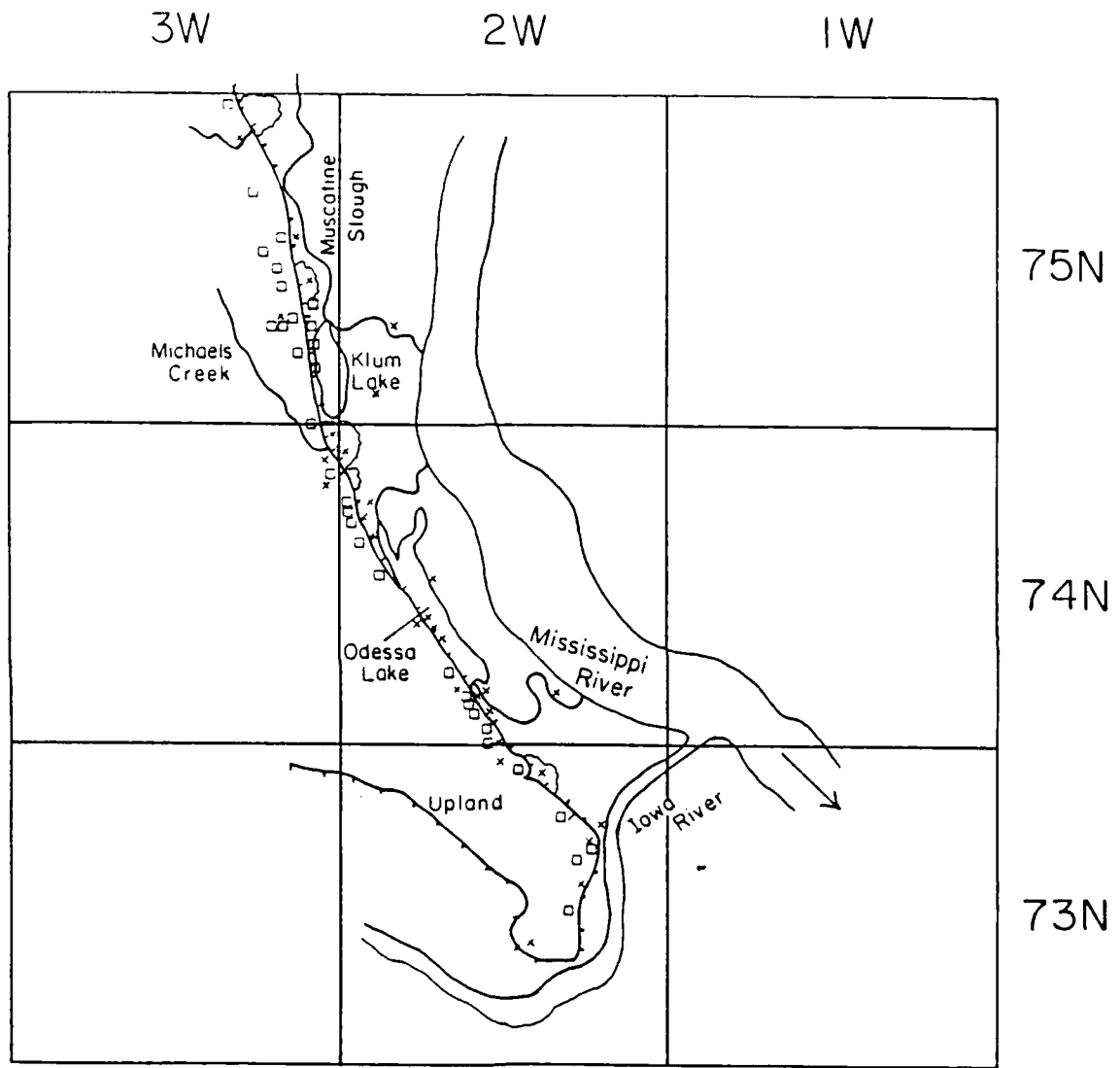

Figure 8.3  
Woodland Age Sites  
x Habitation  
□ Mounds

Bluff  
Fan



## IX RECOMMENDATIONS

### 13LA38 & 13LA30

A strip 5-10m wide and up to 100m long remains of 13LA38. The entire bank along the site is eroding due to the undercutting actions of waves generated by recreational boat traffic on Sand Run Slough. Even the reduced speed limit of "idle" along this section of slough will not halt bank erosion. Some portion of the erosion along the slough is natural, since pieces of the bluff are actively slipping toward the water along the length of the Lake Odessa channel complex. Now that the site has been sampled by the Sand Run investigations (reported here), 13LA38 can be allowed to erode. Bank stabilization would be prohibitively expensive for the small section of site that remains, and heavy equipment probably cannot reach the site anyway.

Site 13LA30 appears to be more intact, although it may be eroding at almost the same rate as 13LA38 (there is no bluff to push 13LA30 into the water). The 13LA30 bank is exposed to boat traffic and is visited by many local collectors who poke at the soil. When water levels are lower, another effort should be made to test the site by doing a controlled surface collections (note: collectors have moved a great deal of material around the site), then by excavating a small number of one meter units where Early Woodland and Late Archaic components are indicated. This site has produced a number of stemmed points and trailed ceramics of the Early Woodland period. Testing for selected purposes is proposed because this is a large site. Doing the 13LA38 excavation project has not diminished the need for investigating 13LA30. The latter site has cultural and natural stratigraphy that would be an important contribution to understanding regional geomorphic/cultural associations in the Mississippi floodplain. Following testing, the decision about mitigative action can be taken with more insight.

### The Upper Mississippi Basin

A summary of the basic results from the Sand Run investigations can be developed into a prospectus on how to deal with the rest of the archaeology of the Upper Mississippi River valley. This exercise will not be an application of findings about prehistoric cultures, however; that was presented in the previous chapters. Rather, a series of suggestions will be formulated about what to look for and what to anticipate in future sessions of floodplain archaeology.

There are three broad issues that override all the specific suggestions I will make shortly. These issues are water problems, coordination of research and funding.

The facts of existing impoundment pools and the maintenance of water levels for navigation means that a large portion of the Mississippi River floodplain is difficult to reach with traditional archaeological methods. Furthermore, recent siltation has buried prehistoric sediments farther beneath the water table. A rejoinder naming water as a factor prohibiting some kinds of data collection must be added to every effort to model prehistoric cultures in the valley. New, original ideas for dealing with the water problem are required if archaeological knowledge is to be advanced in the upper valley.

Coordination among researchers also is an issue. Compare, for instance, the proliferation and intensity of archaeological research in the Middle and Lower Illinois Valley, where the Kampsville Center and the Illinois State Museum have been working, with the fragmentary state of archaeological research in the Upper Mississippi River valley. Comparison of the two valleys is barely possible, yet the cultural sequences of both valleys were fundamentally alike. The Corps of Engineers is applying some coordination among archaeological contractors through its review and compliance program. Archaeologists themselves must take the initiative for the exchange of ideas and information by referring to past investigations and testing the hypotheses of previous researchers.

Funding of archaeology always will be an issue in a huge valley like the Mississippi. There are many sites with good stratigraphy and impressive artifact contents. If research and mitigation funds are allocated only to threatened sites on an ad hoc basis, there still will not be enough money. A plan for prioritizing research/mitigation efforts is needed, if funding continues to be restricted. Of course, an opportunity for a privately funded, region-wide research program, such as Kampsville operation, would profoundly enhance mitigation research in the Upper Mississippi Basin.

Other suggestions for future research in the Mississippi valley cover specific problems. These are annotated below.

\*\* Archaeobotany. Economic changes mean changes in the relations of social-labor; this is not the sort of direct evidence that can be dug from an archaeological site. The products of economic change materialize as changes in subsistence practices, the evidence for which can be excavated in the form of bones, plants and tools. Of all forms of hard evidence, plant remains are emerging as one of the most critical indicators of economic changes in the prehistoric Midwest. The development and spread of native seed horticulture and eventual cultivation of squash, maize and beans are the profound changes being referred to. The discipline of archaeobotany is relatively new and constantly

producing more sophisticated techniques and information about prehistoric plants. Specialization in the identification of plant and seed morphologies is becoming necessary for the recognition of evidence for early horticulture. This renders archaeobotanical studies more costly. Under present conditions of constrained funding, I would give archaeobotanical studies priority over analysis of faunal remains.

**\*\* Lithics.** There can be no issue with the observation that very detailed analyses of lithic remains provide evidence for a range of human behaviors: e.g. exchange, site function, technologies and industries, social status. The inherent problem with lithic studies is that massive numbers of attributes must be measured and observed before a limited number of attributes can be recognized for their social or economic significance. In other words, the study of lithics can be a situation of diminishing returns. I have four suggestions derived from experiences with Iowa collections. a) Expend less effort on identifying all the varieties of fire-cracked rock; simply weight gross categories, such as igneous/metamorphic and sedimentary rock. b) Use the time saved on fire-cracked rock to locate and analyze cobble tools. c) Commit the largest analytical efforts to lithic collections from stratified and single component sites, and expend less time and energy on sites with hopelessly mixed components. d) Pursue opportunities to survey outcrops of lithic materials and to develop comparative collections of these materials.

**\*\* Ceramics.** In the ceramics chapter, two suggestions were advanced. First, all ceramic analyses should include attribute and metric data so that direct comparisons can be made by other researchers. Second, more studies are needed on collections housed in public facilities. In terms of culture history, the development of ceramic typologies will be the central elements (along with lithic typologies and burial modes) in the delineation of prehistoric phases for Woodland cultures in eastern Iowa. Specifically, the phases of the Middle Woodland period (beyond the McGregor phase) need to be described and named--whether they belong to the Illinois valley sequence or to a new nomenclature. The Late Woodland period also needs phase definitions in terms of clarifying Minotts phase and naming phases for ca. A.D. 600-800 in southeastern Iowa, central Iowa and perhaps southern Iowa.

**\*\* Faunal Remains.** Preservation of bones is inconsistent in the Mississippi valley environ. Where evidence suggests the presence of more calcareous alluvium, shell heaps or middens, archaeologists should be prepared to commit time and funding to the analysis of faunal remains. It was observed at Sand Run that water screening of all excavated matrix would have improved the recovery of bones. When bone preservation is poor and the reasons for variable preservation are not clear, a detailed faunal analysis might be unnecessary and if done might lead to unfounded interpretations (e.g. based on "negative" evidence).

**\*\* Landforms.** The Sand Run investigation proffered another application of geoarchaeology besides its common use in regional studies. The internal structure of a terrace and fan formation determined the arrangement of the excavation blocks and stratigraphic levels. The actual digging of the site was practically an exercise in rote application of methods: trowelling and shovel-skimming a predetermined floor angle and reading feature stains at specified intervals within the soil stratigraphy. The significant point is that the parameters of research were preconceived because of the type and arrangement of landforms at the Sand Run Slough site. This approach can work in another way as well. Researchers can take advantage of certain conditions in a landform to examine specific kinds of evidence. For instance, fans are more likely to yield "pure" components and intra-site patterning from discrete soil horizons, while middens will yield assemblages large enough to be statistically relevant. Likewise, areas of rapid deposition produce more separation of components than vertically compressed sediments. Later, when soils are secured as horizon markers, the stratigraphic context of a soil will partially determine its research potential.

**\*\* Valley Floor Archaeology.** Local collectors know a great deal more about sites in the Muscatine Island area than archaeologists. They know where sites are located, how water levels affect sites, and where artifact concentrations occur on large sites. Archaeological surveys should start with collector information. When a site bigger than a few meters is located in alluvium, care should be taken to relate artifact concentrations to variations in sediments. The site surface should be gridded in 10m intervals and a controlled collection made of diagnostic materials. Surface controls will reveal the loci of major components and make subsequent testing more precise and effective. Test excavations might consist of patterned postholing to determine the extent of cultural layers and test squares to relate diagnostic artifacts to soil/sedimentary stratigraphy. From the experience in heavy textured alluvial sediments at Sand Run, test pits can sometimes be excavated well below (+50cm?) the apparent water table before water inundates the unit hours later.

**\*\* Site Mitigations.** Boat traffic in the Upper Mississippi basin has accelerated the destruction of sites because waves from boat wakes undercut bank vegetation. The consequence is the exposure and destruction of increasing numbers of sites. The costs of mitigating all site impacts is prohibitive, aside from the fact that excavating all threatened sites would produce redundant information. A plan is needed for prioritizing mitigative efforts. Here are a few suggestions.

**\*\*** The costly and long-term commitment to bank stabilization to preserve a site should be undertaken only for largely intact sites, such as mound groups, significant historic towns, large proto-historic villages and locations with unique historical significance. Temporary bank



stabilization to delay erosion until archaeological actions can be undertaken may be an alternative to long-term protection.

\*\* A mitigation program of testing and excavations should be done on a regional scale. Arrays of all impacted sites should be broken down into types of sites (e.g. cultural ages, number of components, landform stratigraphy, preservation potentials) so that it can be determined which sites will potentially resolve what research questions. Then, a sample of each type of site should be investigated according to a schedule prioritized by available funds and the degree of impacts. It is important to investigate sites by type rather than the relative richness of their assemblages, and to sample one of every site type before duplicating investigations on sites of the same type. This approach will help us to discover the variability of prehistoric cultures and to discover new kinds of information.

## REFERENCES CITED

- Alex, Lynn  
 1978 The Poison Ivy site: A new Oneota site in southeastern Iowa. *Journal of the Iowa Archeological Society* 25:78-91.
- Alex, Robert  
 1968 The Rock Run Shelter: A Stratified Woodland Site in East Central Iowa. Unpublished Masters Thesis, Department of Anthropology, University of Iowa, Iowa City.
- Anderson, Adrian D.  
 1958 Suggested manner of mound construction. *Newsletter of the Iowa Archeological Society* 28:7.
- 1971a Review of Iowa River valley archaeology. In *Prehistoric Investigations*, ed. Marshall McKusick. Pp. 1-23. Office of the State Archaeologist, Reports no. 3, Iowa City.
- 1971b The Late Woodland Walters site. In McKusick ed. Pp. 24-52.
- Anfinson, Scott F. ed.  
 1979 A handbook of Minnesota prehistoric ceramics. Occasional Publications in Minnesota Anthropology 5. Fort Snelling.
- Appelget, John and Lloyd L. Smith Jr.  
 1950 The determination of age and rate of growth from vertebrae of the channel catfish *Ictalurus Lacustris Punctatus*. *American Fisheries Society Transactions* 80:119-139.
- Asch, David L. and Nancy B. Asch  
 1976 Paleoethnobotany of the Koster site: an interim report. *Archeobotanical Laboratory Report* 10. Northwestern University Archeological Program, Evanston and Kampsville.
- 1985a Prehistoric plant cultivation in west-central Illinois. In *Prehistoric food production in North America*, ed. R. I. Ford. Pp. 149-203. *Museum of Anthropology University of Michigan Anthropological Papers* 75. Ann Arbor.

Asch & Asch (cont.)

- 1985b Archeobotany. In Smiling Dan: structure and function at a Middle Woodland settlement in the Illinois Valley, edited by B. D. Stafford and M. B. Sant. Pp. 327-401. Kampsville Archeological Center Research Series 2. Center for American Archeology, Kampsville, Illinois.

Asch, David L., Kenneth B. Farnsworth and Nancy B. Asch

- 1979 Woodland subsistence and settlement in west central Illinois. In Hopewell archaeology: the Chillicothe Conference, eds. D. S. Brose and N. Greber. Pp. 80-85. Kent State University Press, Kent, Ohio.

Asch, Nancy B. and David L. Asch

- 1978 The economic potential of Iva annua and its prehistoric importance in the lower Illinois Valley. In The nature and status of ethnobotany, ed. R. I. Ford. Pp. 300-341. University of Michigan Museum of Anthropology, Anthropological Papers 67. Ann Arbor.
- 1980 The Dickson Camp and Pond sites: Middle Woodland archaeobotany in Illinois. In Dickson Camp and Pond: two early Havana Tradition sites in the central Illinois Valley, by Anne-Marie Cantwell. Pp. 152-160. Illinois State Museum Reports of Investigations 36. Springfield.
- 1985 Archeobotany. In Deer Track: A Late Woodland Village in the Mississippi Valley, eds. C.R. McGimsey and M.C. Conner. Pp. 44-117. Center for American Archeology, Kampsville Archeological Center, Technical Report no. 1.

Asch, Nancy B., Richard I. Ford and David L. Asch

- 1972 Paleoethnobotany of the Koster site: the Archaic horizons. Illinois State Museum Reports of Investigations 24. Springfield.

Baerreis, David A.

- 1953 Blackhawk village site (Da5) Dane County, Wisconsin. Journal of the Iowa Archeological Society 2(4):5-20.

Bailey, Anthony W.

- 1977 A Report on the Bennett-Roth Site, 11HE62: A Surface-Collected Site in Henderson County, Illinois. Unpublished Masters Thesis, Department of Anthropology, Northern Illinois University, DeKalb.

Bareis, Charles J., and James W. Porter eds.

- 1984 American Bottom Archaeology. University of Illinois Press, Urbana.

- Barnhardt, Michael L., et al  
 1983 Preliminary cultural resource survey and geomorphological assessment of selected areas in navigation Pool 16, Mississippi River. *The Wisconsin Archeologist* 64(1,2):9-110.
- Benchley, Elizabeth, Michael Gregg and Mark J. Dudzik  
 1977 Recent Investigations at Albany Mounds, Whiteside County, Illinois. Illinois Archaeological Survey, Circular no. 2.
- Benchley, Elizabeth, Harold Hassen and William Billeck  
 1979 Final report of archaeological investigations at the Sloan site (11-Mc-86) FAS Project 1210, Mercer County, Illinois. Archaeological Research Laboratory Report of Investigations no. 36. Milwaukee.
- Benchley, Elizabeth, et al  
 1981 Rock River, Upper Mississippi River, Little Wabash River, Lower Wabash River Units (I, III-north, and VIII). *In Predictive Models in Illinois Archaeology*, ed. M. K. Brown. Pp. 1-20. Illinois Department of Conservation.
- Bender, Barbara  
 1979 Gatherer-Hunter to Farmer: A social perspective. *World Archaeology* 10(2):204-222.
- 1985a Emergent tribal formations in the American midcontinent. *American Antiquity* 50(1):52-62.
- 1985b Prehistoric developments in the American midcontinent and in Brittany, northwest France. *In Prehistoric Hunters-Gatherers*, eds. T. D. Price and J. A. Brown. Pp. 21-57. Academic Press, New York.
- Benn, David W.  
 1978 The Woodland ceramic sequence in the culture history of northeast Iowa. *Mid-Continental Journal of Archaeology* 3(2):215-283.
- 1979 Some trends and traditions in woodland cultures of the Quad-State region in the Upper Mississippi River basin. *The Wisconsin Archeologist* 60(1):47-82.
- 1980 Hadfields Cave. Office of the State Archaeologist of Iowa, Report 13. Iowa City.
- 1982 The ceramic assemblage. Pp.38-86. Arthur site ceramics in regional perspective, Pp.161-188. *In A Preliminary Report on the Arthur Site, East Okoboji Lake, Iowa*, ed. J. A. Tiffany. Research Papers Series 7(1). Office of the State Archaeologist, Iowa City.

Benn (cont.)

- 1983 Diffusion and acculturation in Woodland cultures on the western Prairie Peninsula. In Prairie Archaeology: Papers in Honor of David A. Baerreis, ed. G. E. Gibbon. 75-86. University of Minnesota Publications in Anthropology 3. Minneapolis.
- 1984a Archaeological salvage excavations at Sid's site (13KK16): a Woodland campsite in Keokuk County, Iowa: 1983. Center for Archaeological Research, project CAR-574. Springfield.
- 1984b Excavations at the Christenson Oneota Site (13PK407), Central Des Moines River Valley, Iowa. Saylorville, Iowa. Research Report No. 592, Center for Archaeological Research, Southwest Missouri State University, Springfield.
- 1986 Site Testing for the Interpretive Cultural Overview, Saylorville Lake, Iowa. Center for Archaeological Research Project 627-III. Springfield.

Benn, David W. ed.

- 1981 Archaeological Investigations at the Rainbow Site, Plymouth County, Iowa. Luther College Archaeological Research Center, Decorah.

Benn, David W. and E. Arthur Bettis

- 1977 Salvage Excavations at the John Henry Mound (13WH105), Winneshiek County, Iowa. Luther College Archaeological Research Center, Decorah.
- 1978 Phase II Investigations at the Louisa Project. Luther College Archaeological Research Center, Decorah.

Benn, David W. and Joyce McKay

- 1977 Archaeological, Historical and Cultural Studies in the Louisa Project. Luther College Archaeological Research Center, Decorah.

Benn, David W., R. Clark Mallam and E. Arthur Bettis III

- 1978 Archaeological investigations of the Keller Mounds (13AM69) and related manifestations: Insights into Woodland Indian mythology. Research Papers 3(3), Office of the State Archaeologist, Iowa City.

Benn, David W., and Leah D. Rogers

- 1985 Interpretive Overview of Cultural Resources in Saylorville Lake, Iowa. Center for Archaeological Research Project 627-II. Springfield.

- Benn, David W. and Dean M. Thompson  
 1977 The Young site, Linn County, Iowa, and comments on woodland ceramics. *Journal of the Iowa Archeological Society* 24:1-61.
- Bennett, John W.  
 1945 *Archaeological Explorations in Jo Daviess County, Illinois*. University of Chicago Press, Chicago.
- Bettis, E. Arthur III  
 1984 New Conventions for the Description of Soil Horizons and Layers. *Plains Anthropologist*, 29(103):57-59.
- Bettis, E. Arthur III and David W. Benn  
 1984 An archaeological and geomorphological survey in the central Des Moines River Valley, Iowa. *Plains Anthropologist* 29(105):211-227.
- Bettis, E. Arthur III and B. E. Hoyer  
 1983 Geomorphology and Pedology of the Michael's Creek Fan. In *Iowa's Great River Road, Louisa County*. Pp. 2.9-2.13. The Cultural Resource Group, Louis Berger and Associates, Inc., East Orange.
- 1986 Late Wisconsinan and Holocene landscape evolution and alluvial stratigraphy in the Saylorville Lake area, Central Des Moines River Valley, Iowa. *Iowa Geological Survey, Open File Report 86-1, 1986*.
- Bettis, E. Arthur III and Dean M. Thompson  
 1981 Holocene landscape evolution in western Iowa: concepts, methods and implications for archeology. *Current Directions in Midwestern Archaeology*. Papers from the Mankato Conference. Minnesota Historical Society Occasional Publications in Anthropology 9:1-14. St. Paul.
- Billeck, William T.  
 1986a Lithics. In *Archaeological Investigations of the F-518 Corridor*, ed. S. C. Lensink. *Quaternary Studies Contributions of the University of Iowa*, Iowa City.
- 1986b Excavations at the Smith site, Iowa: 1955 and 1985. Paper presented at the thirty-sixth annual meeting of the Iowa Archeological Society, Iowa City.



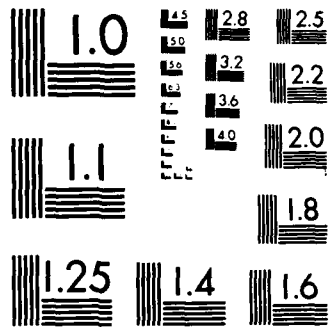

MICROCOPY RESOLUTION TEST CHART  
NATIONAL BUREAU OF STANDARDS-1963-A



- Birmingham, Nancy Ryden  
 1985 Lithic assemblages of the Moline chert source area, Rock Island and Henry Counties, Illinois. Lithic Resource Procurement: Proceedings from the Second Conference of Prehistoric Chert Exploitation, ed. S. C. Vehik. Pp. 133-152. Center for Archaeological Investigation, Occasional Paper no. 4, Southern Illinois University, Carbondale.
- Blumer, Reverend Adolph  
 1881 Explorations of mounds in Louisa County, Iowa. Proceedings of the Davenport Academy of Natural Sciences 3:132-133 (1879-1881).
- Boszhardt, Robert F. and David F. Overstreet  
 1983 Preliminary investigations: Archaeology and sediment geomorphology, navigation Pool 12, Upper Mississippi River. The Wisconsin Archeologist 64(1,2):111-183.
- Bowles, John B.  
 1975 Distribution and biogeography of mammals of Iowa. Texas Tech University Museum, Special Publication no. 9.
- Braun, David P.  
 1977 Middle Woodland-Early Late Woodland Social Change in the Prehistoric Central Midwestern U.S. Unpublished Ph.D Dissertation, Department of Anthropology, University of Michigan, Ann Arbor.  
 1981 A critique of some recent North American mortuary studies. American Antiquity 46(2):398-416.  
 1983 Pots as tools. In The Hammer Theory of Archaeological Research, eds. J. A. Moore and A. S. Keene. Pp. 107-134. Academic Press, New York.
- Brose, David S. and N'omi Greber, editors.  
 1979 Hopewell Archaeology. Kent State University Press, Kent.
- Brown, James A.  
 1979 Charnel houses and mortuary crypts: Disposal of the dead in the Middle Woodland period. In Hopewell Archaeology, eds. D.S. Brose and N. Greber. Pp. 211-219. Kent State University Press, Kent.  
 1985 Long-term trends in sedentism and the emergence of complexity in the American Midwest. In Prehistoric Hunters-Gatherers, eds. I. D. Price and J. A. Brown. Pp. 201-231. Academic Press, New York.

Brown (cont.)

- 1986 Early ceramics and culture: A review of interpretations. Pp. 598-608. In Farnsworth and Emerson eds.
- Brown, James A. and Robert K. Uierra  
1983 What happened in the Middle Archaic? Introduction to an ecological approach to Koster site archaeology. In Archaic Hunters and Gatherers in the American Midwest, eds. J. L. Phillips and J. A. Brown. Pp. 165-195. Academic Press, New York.
- Brown, Melvin D.  
n.d. Advance Report-Part I, Soil Survey of Louisa County, Iowa. (1984) United States Department of Agriculture, Soil Conservation Service.
- Callahan, Errett  
1979 The basics of biface knapping in the Eastern Fluted Point tradition: A manual for flintknappers and lithic analysts. Archeology of Eastern North America 7(1):1-180.
- Cantwell, Anne-Marie  
1980 Dickson Camp and Pond: Two early Havana tradition sites in the Central Illinois valley. Illinois State Museum, Reports of Investigations no. 36. Springfield.
- Casteel, Richard W.  
1972 Some archeological uses of fish remains. American Antiquity 37(3):404-419.
- Chapman, Carl H.  
1975 Archeology of Missouri, Vol. I. University of Missouri Press, Columbia.  
1980 Archeology of Missouri, Vol. II. University of Missouri Press, Columbia.
- Charles, Douglas K.  
1985 Corporate Symbols: An Interpretive Prehistory of Indian Burial Mounds in West-central Illinois. Unpublished Ph.D. Dissertation, Department of Anthropology, Northwestern University, Evanston.
- Charles, Douglas K. and Jane E. Buikstra.  
1983 Archaic mortuary sites in the central Mississippi drainage: distribution, structure, and behavioral implications. In Archaic Hunters and Gatherers in the American Midwest, eds. J. L. Phillips and J. A. Brown. Pp. 117-145. Academic Press, New York.

- Charles, Douglas K., Jane E. Buikstra and Lyle W. Konigsberg  
 1986 Behavioral implications of Terminal Archaic and Early Woodland mortuary practices in the Lower Illinois valley. Pp. 458-474. In Farnsworth and Emerson eds.
- Chomko, Stephen A., and Gary W. Crawford  
 1978 Plant husbandry in prehistoric eastern North America: new evidence for its development. *American Antiquity* 43(3):405-408.
- Christiansen, James  
 1981 Population trends among Iowa's amphibians and reptiles. *Proceedings of the Iowa Academy of Science* 88(1):24-27.
- Church, Peter E.  
 n.d. The archaeological Potential of Pool no. 10, Upper Mississippi River; a Geomorphological Perspective. U.S. Army Engineers Waterways Experiment Station, Vicksburg.
- Conrad, Lawrence A.  
 1981 An introduction to the archaeology of upland west central Illinois: A preliminary archaeological survey of the Canton to Quincy corridor for the proposed FAP-407 highway project. Archaeological Research Laboratory, Western Illinois University, Reports of Investigations 2.
- Cook, Thomas Genn.  
 1976 Koster: an artifact analysis of two Archaic phases in west-central Illinois. *Northwestern Archeological Program Prehistoric Records* no. 1. Evanston.
- Cook, Thomas G. and Ann L. Koski  
 1985 Analysis of stone tools and lithic debris. In Massey and Archie: A Study of Two Hopewellian Homesteads in the Western Illinois Uplands, eds. K. B. Farnsworth and A.L. Koski. Pp. 67-123. Center for American Archeology, Kampsville Archeological Center, Research Series Vol. 3. Kampsville.
- Corps of Engineers  
 1985 Cultural resources reconnaissance at prehistoric sites 13LA30 and 13LA38, Mississippi River Sand Run Slough, Louisa County, Iowa. Rock Island.
- Cowan, C. Wesley  
 1985 Understanding the evolution of plant husbandry in eastern North America: lessons from botany, ethnography and archaeology. In Prehistoric food production in North America, ed. R. I. Ford. Pp. 205-243. University of Michigan Museum of Anthropology, *Anthropological Papers* 75. Ann Arbor.

- Donham, Teresa K. and Michael J. O'Brien  
 1986 Ceramics and chronology. In Archaeology of the central Salt River valley: An overview of the prehistoric occupation, by M. J. O'Brien. The Missouri Archaeologist 46:191-202.
- Emerson, Thomas E.  
 1986 A retrospective look at the Earliest Woodland cultures in the American heartland. Pp. 621-633. In Farnsworth and Emerson eds.
- Emerson, Thomas E. and Dale L. McElrath  
 1983 A settlement-subsistence model of the Terminal Late Archaic adaptation in the American Bottom, Illinois. In Archaic Hunters and Gatherers in the American Midwest, eds. J. L. Phillips and J. A. Brown. Pp. 219-242. Academic Press, New York.
- Farnsworth, Kenneth B.  
 1986 Black Sand culture origins and distribution. Pp. 634-641. In Farnsworth and Emerson eds.
- Farnsworth, Kenneth B. and David L. Asch  
 1986 Early Woodland chronology, artifact styles, and settlement distribution in the Lower Illinois valley region. Pp. 326-457. In Farnsworth and Emerson eds.
- Farnsworth, Kenneth B. and Thomas E. Emerson eds.  
 1986 Early Woodland Archeology. Center for American Archeology, Kampsville Seminars in Archeology no. 2, Kampsville.
- Farquarson, R.J.  
 1876 Recent archaeological discoveries at Davenport, Iowa. Proceedings of the Davenport Academy of Natural Sciences 1:117-143.
- Fokken, Michael J. and Michael R. Finn  
 1984 Iowa's Great River Road, Louisa County. The Cultural Resource Group, Louis Berger & Associates, Inc., East Orange, N.J.
- Fokken, Michael J. and Derrick J. Marcucci  
 1984 Iowa's Great River Road Louisa County: Phase I and II Archaeological Investigations of the Northern and Southern Segments of County Road X-61. The Cultural Resource Group, Louis Berger & Associates, Inc., East Orange, N.J.
- Ford, Richard I. and David S. Brose  
 1975 Prehistoric wild rice from the Dunn Farm site, Leelanau County, Michigan. The Wisconsin Archeologist 56(1):9-15.

- Fowells, H. A.  
 1965 Silvics of forest trees of the United States. United States Department of Agriculture, Agricultural Handbook 271.
- Fowler, Melvin L.  
 1955 Ware groupings and decorations of woodland ceramics in Illinois. *American Antiquity* 20(3):213-225.
- Fulmer, Darrell, John Kotopp and Alton K. Fisher  
 1977 The Lambert Site 13V882. Office of the State Archaeologist of Iowa, Contract Completion Report no. 71, Iowa City.
- Gass, Reverend J.  
 1881 Explorations of mounds in Louisa County, Iowa. Pp. 140-146. *Ancient Fortifications in Louisa County, Iowa*. Pp. 183-184. *Mounds in Louisa County, Iowa*. Pp. 189-190. *Proceedings of the Davenport Academy of Natural Sciences* 3 (1879-1881).
- Gibbon, Guy  
 1986 Does Minnesota have an Early Woodland? Pp. 84-91. In Farnsworth and Emerson eds.
- Gladfelter, Bruce G.  
 1981 Investigations at the Labras Lake Site, volume III: geomorphological observations in the vicinity of the site. *Department of Geography, University of Illinois, Chicago*.
- 1985 On the interpretation of archaeological sites in alluvial settings. In *Archaeological Sediments in Context*, eds. J. K. Stein and W. R. Farrand. Pp. 41-52. Center for the Study of Early Man, University of Maine, Orono.
- Green, William  
 1976 Preliminary report on the Bauer Branch complex, a Late Woodland manifestation in west central Illinois. *The Wisconsin Archeologist* 57(3):172-188.
- Gregg, Michael L.  
 1974 Three Middle Woodland sites from Henderson County: An apparent congruity with Middle Woodland subsistence settlement systems in the Lower Illinois valley. *The Wisconsin Archeologist* 55(3):231-245.
- Griffin, James B.  
 1952 Some Early and Middle Woodland pottery types in Illinois. In *Hopewellian Communities in Illinois*, ed. T. Deuel. Pp. 95-129. *Illinois State Museum Scientific Papers* no. 5. Springfield.

- Griffin (cont.)  
 1986 Comments on the Kampsville Early Woodland conference.  
 Pp. 609-620. In Farnsworth and Emerson eds.
- Griffin, James B., Richard E. Flanders and Paul F. Titterington  
 1970 The burial complexes of the Knight and Norton Mounds in  
 Illinois and Michigan. Memoirs of the Museum of  
 Anthropology, University of Michigan, no. 2. Ann  
 Arbor.
- Guldner, Ludwig F.  
 1960 Vascular plants of Scott and Muscatine Counties.  
 Davenport Public Museum, Botanical Publication no. 1.  
 Davenport.
- Haas, Daniel R.  
 1985 A Ceramic Typology for the Loseke Creek Phase and Its  
 Potential Relationships with the Sterns Creek Phase.  
 Paper presented at the forty-third Plains  
 Anthropological Conference, Iowa City.
- Hall, Robert L.  
 1979 In search of the ideology of the Adena-Hopewell climax.  
 In Hopewell Archaeology, eds. D.S. Brose and N. Greber.  
 Pp. 258-265. Kent State University Press, Kent.
- 1980 An interpretation of the two-climax model of Illinois  
 prehistory. In Early Native Americans: Prehistoric  
 Demography, Economy, and Technology, ed. D. L. Browman.  
 Pp. 401-462. Mouton Publishers, The Hague.
- Hallberg, G. R.  
 1980 Pleistocene stratigraphy in east-central Iowa. Iowa  
 Geological Survey Technical Information Series No. 10,  
 Iowa City.
- Hallberg, G. R., Wollenhaupt, N. C. and Wickham, J. I.  
 1980 Pre-wisconsinan stratigraphy in southeast Iowa. Iowa  
 Geological Survey Technical Information Series No. 11,  
 pp. 1-110. Iowa City.
- Hansen, R. E.  
 1973 Bedrock topography of southeast Iowa. U.S.G.S.  
 Miscellaneous Geologic Investigations Map I-308.
- Harn, Alan D.  
 1975 Cahokia and Mississippian emergence in the Spoon River  
 are of Illinois. Transactions of the Illinois Academy  
 of Science 68:414-434.
- Hayden, Brian, editor  
 1979 Lithic Use-Wear Analysis. Academic Press, New York.

- Henning, Dale R.  
1971 Great Oasis culture distributions. In Prehistoric Investigations, ed. M. McKusick. Pp. 125-133. Report 3, Office of the State Archaeologist, Iowa City.
- Honea, Kenneth  
1965a A morphology of scrapers and their methods of production. Southwestern Lore 31(2):25-40.
- Hotopp, John ed.  
1977 Iowa's Great River Road Cultural-Natural Resources, Vol. II: Archaeology, Geology and Natural Areas. Iowa Department of Transportation.
- Hoyer, B. E.  
1980 The geology of the Cherokee Sewer Site. In The Cherokee Excavations, D. C. Anderson and H. A. Semken, Jr., eds. Pp. 21-66. Academic Press, New York.
- Hudak, Joseph G.  
1976 Woodland ceramics from the Petersen site. Scientific Publications 3(2). Science Museum of Minnesota, St. Paul.
- Hurley, William M.  
1975 An analysis of Effigy Mound complexes in Wisconsin. Museum of Anthropology, University of Michigan, Anthropological Papers no. 59. Ann Arbor.
- Johannessen, Sissel  
1984 Paleoethnobotany. In American Bottom Archaeology, eds. C. J. Bareis and J. W. Porter. Pp. 197-214. University of Illinois Press, Urbana.
- Johnson, Roger D., et al.  
1985 Cultural resources investigation for 17 public recreation areas, Navigation Pools 13-24, Mississippi River, Iowa, Illinois and Missouri. Contract Completion Report 217, Office of the State Archaeologist of Iowa, Iowa City.
- Kay, Marvin, Frances B. King and Christine K. Robinson  
1980 Cucurbits from Phillips Spring: new evidence and interpretations. American Antiquity 45(4):806-822.
- Keeley, Lawrence H.  
1980 Experimental Determination of Stone Tool Uses. University of Chicago Press, Chicago.
- Kelly, John E., et al  
1984a Late woodland period. In American Bottom Archaeology, eds. C. J. Bareis and J. W. Porter. Pp. 104-127. University of Illinois Press, Urbana.

- Kelly et al (cont.)  
 1984b Emergent Mississippian period. Pp. 128-157. In Bareis and Porter eds.
- King, Frances B. and Donna C. Roper  
 1976 Floral remains from two Middle to early Late Woodland sites in central Illinois and their implications. The Wisconsin Archeologist 57:142-151.
- Kirkpatrick, T.D.  
 1967 A Geologic Study of Louisa County, Iowa. Unpublished Masters Thesis, Department of Geology, University of Iowa, Iowa City.
- Kivett, Marvin F.  
 1949 A Woodland pottery type from Nebraska. Proceedings of the 5th Plains Conference for Archaeology, Notebook no. 1:67-69. Laboratory of Anthropology, University of Nebraska, Lincoln.  
 1952 Woodland sites in Nebraska. Publications in Anthropology 1. Nebraska State Historical Society, Lincoln.
- Lensink, Stephen C. ed.  
 1986 Archaeological investigations along the F-518 corridor: phase III mitigation of 12WS61, 13WS65, 13WS122, 13WS126. Iowa Quaternary Studies Contribution 9. University of Iowa, Iowa City.
- Lewis, Barry R.  
 1983 Archaic adaptations to the Illinois prairie: the Salt Creek region. In Archaic Hunters and Gatherers in the American Midwest, eds. J. L. Phillips and J. A. Brown. Pp. 99-116. Academic Press, New York.
- Lindley, Clarence  
 1876 Mound explorations in 1875. Proceedings of the Davenport Academy of Natural Sciences 1.
- Lippincott, Kerry A. and Elaine Bluhm Herold  
 1965 Archaeological investigation along Henderson Creek drainage projects, Henderson County, Illinois. In Middle Woodland Sites in Illinois. Pp. 95-128. Illinois Archaeological Survey, Bulletin no. 5.
- Logan, Wilfred D.  
 1976 Woodland Complexes in Northeastern Iowa. Publications in Archaeology 15, National Park Service. Washington, D.C.



- Lopinot, Neal H.  
 1983 Analysis of flotation sample material from the Late Archaic horizon. In The 1982 excavations at the Cahokia Interpretive Center Tract, St. Clair County, Illinois, by M. S. Nassaney, et al. Pp. 77-108. Center for Archaeological Investigations Research Paper 37, Southern Illinois University, Carbondale.
- 1984a Archaeobotanical Formation Processes and Late Middle Archaic Humanplant Interrelationships in the Midcontinental U.S.A. Ph.D. dissertation, Department of Anthropology, Southern Illinois University, Carbondale.
- 1984b Archaeobotanical remains. In Ancillary investigations at the O'Fallon site (23SC556), northcentral St. Charles County, Missouri, by Joseph M. Nixon, et al. Pp. 115-137. Archaeological Survey Research Report 18, University of Missouri, St. Louis.
- Lopinot, Neal H. and David E. Brussell  
 1982 Assessing uncarbonized seeds from open-air in mesic environments: an example from southern Illinois. Journal of Archaeological Science 9:95-108.
- Loy, James D.  
 1968 A comparative style analysis of Havana series pottery from two Illinois valley sites. In Hopewell and Woodland Site Archeology in Illinois. Pp. 129-196. Illinois Archaeological Survey Bulletin 6, Springfield.
- McConaughy, Mark A., Claude U. Jackson and Frances B. King  
 1985 Two Early Mississippian period structures from the Rench site (11P4), Peoria County, Illinois. Midcontinental Journal of Archaeology 10(2):171-194.
- McElrath, Dale L., et al.  
 1984 Late Archaic period. In American Bottom Archaeology, eds. C. J. Bareis and J. W. Porter. Pp. 36-58. University of Illinois Press, Urbana.
- McGimsey, Charles R.  
 1985 Lithics. In Deer Track: A Late Woodland Village in the Mississippi Valley, eds. C.R. McGimsey and M.D. Conner. Pp. 17-27. Center for American Archeology, Kampsville Archeological Center, Technical Report no. 1.
- McGimsey, Charles R. and Michael D. Conner eds.  
 1985 Deer Track: A Late Woodland Village in the Mississippi Valley. Center for American Archeology, Kampsville Archeological Center, Technical Report no. 1. Kampsville.

- McGregor, John C.  
1957 Prehistoric village distribution in the Illinois River valley. *American Antiquity* 22(3):272-279.
- McKern, William C.  
1931 A Wisconsin Variant of the Hopewell Culture. *Public Museum of the City of Milwaukee, Bulletin* 10(2).
- McKusick, Marshall  
1970 The Davenport Conspiracy. *Office of the State Archaeologist of Iowa, Report no. 1.* Iowa City.
- Mallam, R. Clark.  
1976 The Iowa Effigy Mound Manifestation: An Interpretive Model. *Report no. 9. Office of the State Archaeologist, Iowa City.*
- Markman, Charles W.  
1986 Above the American Bottom: The Late Woodland-Mississippian Transition in Northeastern Illinois. Paper presented at the Society for American Archaeology Meeting, New Orleans.
- Markman, Charles W. and Paul P. Kreisa  
1986 Early Woodland adaptation along the Lower Rock River, Illinois. Pp. 179-190. *In* Farnsworth and Emerson eds.
- Martin, A. C. and W. D. Barkley  
1961 Seed identification manual. *University of California Press, Berkeley.*
- Menzel, Bruce  
1981 Iowa waters and fishes: A century and a half of change. *Proceedings of the Iowa Academy of Science* 88(1):17-23.
- Michlovic, Michael G.  
1986 Cultural evolutionism and Plains archaeology. *Plains Anthropologist* 31(113):207-219.
- Mohlenbrock, Robert H., and Douglas M. Ladd  
1978 Distribution of Illinois vascular plants. *Southern Illinois University Press, Carbondale.*
- Moore, Kurt R.  
1981 Prehistoric Chert Exploitation in Cedar Creek and Northwest Central Illinois: A Preliminary Overview. Paper presented at the Conference on Prehistoric Chert Exploitation, Center for Archaeological Investigation, Southern Illinois University, Carbondale.

- Morgan, David T.  
 1985a Ceramic analysis. In Smiling Dan, eds. B.D. Stafford and M.B. Sant. Pp. 183-257. Center for American Archeology, Kampsville Archeological Center, Research Series Vol. 2. Kampsville.
- 1985b Late Woodland ceramics from the Fall Creek locality, Adams County, Illinois. The Wisconsin Archeologist 66(3):265-281.
- Morgan, David T., David L. Asch and C. Russel Stafford  
 1986 Marion and Black Sand occupations in the Sny Bottom of the Mississippi valley. Pp. 207-230. In Farnsworth and Emerson eds.
- Morrow, Toby  
 1984 Iowa Projectile Points. Special Publication, Office of the State Archaeologist, Iowa City.
- Movius, Hallam L., Jr., et al.  
 1968 The analysis of certain major classes of Upper Paleolithic tools. Bulletin no. 26, American School of Prehistoric Research, Peabody Museum, Harvard University, Cambridge.
- Munson, Patrick J.  
 1982 Marion, Black Sand, Morton and Havana relationships: an Illinois valley perspective. The Wisconsin Archeologist 63(1):1-17.
- 1986 Black Sand and Havana tradition ceramic assemblages and culture history in the Central Illinois River valley. Pp. 280-300. In Farnsworth and Emerson eds.
- Munson, Patrick J., Paul W. Parmalee and Richard A. Yarnell  
 1971 Subsistence ecology of Scovill, a terminal Middle Woodland village. American Antiquity 36(4):410-431.
- Newcomer, M.H.  
 1971 Some quantitative experiments in handaxe manufacture. World Archeology 3:85-93.
- Newhall, John  
 1841 Sketches of Iowa. J.H. Colton, New York.
- O'Brien, Michael J.  
 1980 Theoretical considerations concerning the study of Hunter-Gatherer societies. In Archaic Prehistory on the Prairie-Plains Border, ed. A.E. Johnson. Pp. 113-120. University of Kansas, Publications in Anthropology no. 12, Lawrence.

- O'Brien, Patricia J.  
 1972 A formal analysis of Cahokia ceramics from the Powell Tract. Illinois Archaeological Survey, Monograph 3.
- Odell, George H.  
 1985 Microwear analysis of Middle Woodland lithics. In Smiling Dan, eds. B.D. Stafford and M.B. Sant. Pp. 298-326. Center for American Archaeology, Kampsville Archeological Center, Research Series Vol. 2. Kampsville.
- Odell, George H. and Frieda Odell-Vereecken  
 1980 Verifying the Reliability of the Lithic Use-Wear Assessments by "Blind Tests", the Low-Power Approach. Journal of Field Archeology 7(1):87-120.
- Orr, Ellison  
 1935 Report of a state-wide reconnaissance survey of Indian mound groups and excavation of camp sites, under project 1047 of the Iowa Planning Board, Vol. 2. Manuscript on file at the Office of the State Archaeologist, Iowa City.
- Osborn, Nancy M. and David M. Gradwohl  
 1981 Saylorville Stage 2 Contract Completion Report: Archaeological Investigations in the Saylorville Lake Project, Iowa. Iowa State University Archaeological Laboratory, Ames.
- Overstreet, David F.  
 1984a Archaeological Reconnaissance Survey of Pool 10, Upper Mississippi River, Grant and Crawford Counties, Wisconsin, and Allamakee and Clayton Counties, Iowa. Reports of Investigations no. 139, Great Lakes Archaeological Research Center, Wauwatosa.
- 1984b Archaeological Investigations at the Grant River Public Use Area. Great Lakes Archaeological Research Center, Inc., Reports of Investigations no. 149. Wauwatosa.
- Panshin, A. J., and Carl De Zeeuw  
 1980 Textbook of wood technology, Volume I (4th edition). McGraw-Hill, New York.
- Parmalee, Paul W., Andreas A. Paloumpis and Nancy Wilson  
 1972 Animals utilized by Woodland peoples occupying the Apple Creek site, Illinois. Illinois State Museum, Reports of Investigations no. 23. Springfield.
- Perino, Gregory  
 1968 Guide to the Identification of Certain American Indian Projectile Points. Special Bulletin no. 3, Oklahoma Anthropological Society.

Perino (cont.)

- 1973 The Late Woodland component at the Pete Klunk site, Calhoun County, Illinois. Late Woodland Site Archaeology in Illinois I: Investigations in South-Central Illinois. Illinois Archaeological Survey, Inc., Bulletin no. 9, Urbana.

Perry, Michael

- 1982 Phase II investigation Louisa County. Office of the State Archaeologist, Contract Completion Report no. 5 (41). Iowa City.

Pratt, W.H.

- 1878 On the explorations of the mounds on the farm of Col. William Allen. Proceedings of the Davenport Academy of Natural Sciences 2:148-150.

Price, T. Douglas, and James A. Brown

- 1985 Aspects of Hunter-Gatherer Complexity. In Prehistoric Hunters-Gatherers, eds. T.D. Price and J.A. Brown. Pp. 3-20. Academic Press, New York.

Riggle, Stan

- 1981 The Late Woodland Transition in the central Mississippi valley: AD 700-1100. South Dakota Archaeology 5.

Ritzenthaler, Robert

- 1967 A Guide to Wisconsin Indian Projectile Point Types. Milwaukee Public Museum.

Roper, Donna

- 1984 A Preliminary Evaluation of Lithic Technology at Lake Red Rock. Newsletter of the Iowa Archeological Society, No. 111:3-6.
- 1986 Archeological Survey and Testing at Lake Red Rock, Iowa: The 1984 and 1985 Seasons. Gilbert/Commonwealth Inc., Jackson.

Scholtz, James A.

- 1958 Description of pottery vessels recovered from the burial chamber of a Middle Woodland burial mound. Newsletter of the Iowa Archeological Society 28:7.

Schumm, Stanley A.

- 1977 The Fluvial System. Wiley-Interscience, New York.

Seeman, Mark F.

- 1979 The Hopewell Interaction Sphere: The evidence for interregional trade and structural complexity. Indiana Historical Society, Prehistory Research Series 0(2). Indianapolis.

- Semenov, S.A.  
1964 Prehistoric Technology. Translated by M.W. Thompson. Adams and Dart, England.
- Shimek, Bohumil  
1911 The Prairies. Contributions from the Laboratories of Natural History 6(35). State University of Iowa, Ames.
- Slattery, R.G., G.A. Horton and M.E. Ruppert  
1975 The McKinney Village site: An Oneota site in southeastern Iowa. Journal of the Iowa Archaeological Society 22:35-61.
- Soil Survey Staff  
1951 Soil Survey Manual. U.S. Department of Agriculture Handbook 18, Washington, D.C.  
  
1975 Soil Taxonomy. U.S. Department of Agriculture Handbook 436, Washington, D.C.
- Stafford, Barbara D.  
1985 Lithic analysis. In Stafford and Sant eds. Pp. 258-287.
- Stafford, Barbara D. and Mark B. Sant eds.  
1985 Smiling Dan: Structure and Function at a Middle Woodland Settlement in the Illinois Valley. Center for American Archeology, Kampsville Archeological Center, Research Series Vol. 2. Kampsville.
- Stanley, David G.  
1986a Phase II Investigations at 13LE186, Fort Madison, Iowa. Highland Cultural Research Center Report 93. Highlandville.  
  
1986b Phase I Cultural Resource Survey for a Strip Mine Reclamation Project in Van Buren and Marion Counties, Iowa: Wilcox and Hughes/Phillips Tracts. Highland Cultural Research Center, Highlandville.  
  
1987 Phase II Archeological Investigations at 13VBS68, Van Buren County, Iowa. Prepared for the United States Department of Agriculture, Soil Conservation Service, Des Moines.
- Starr, Frederick  
1895 Summary of the archaeology of Iowa. Proceedings of the Davenport Academy of Natural Sciences 6:88-98.  
  
1897 Bibliography of Iowa antiquities and summary of the archaeology of Iowa. Proceedings of the Davenport Academy of Natural Sciences 6:1-24, 53-124.

- Steyermark, Julian A.  
1980 Flora of Missouri. Iowa State University Press, Ames.
- Stickney, Gardner P.  
1896 Indian use of wild rice. American Anthropologist 9(4):115-122.
- Stoltman, James B.  
1979 Middle Woodland stage communities of southwestern Wisconsin. In Hopewell Archaeology, eds. D. S. Brose and N. Greber. Pp. 122-139. Kent State University Press, Kent.
- 1986 The Prairie phase: An Early Woodland manifestation in the Upper Mississippi valley. Pp. 121-136. In Farnsworth and Emerson eds.
- Straffin, Dean F.  
1971 Wolfe Havana Hopewell site. In Prehistoric Investigations, ed. M. McKusick. Pp. 53-65. Office of the State Archaeologist, Report no. 3, Iowa City.
- Struever, Stuart  
1960 The Kamp Mound Group and a Hopewell Mortuary Complex in the Lower Illinois Valley. Unpublished Masters Thesis, Department of Anthropology, Northwestern University, Evanston.
- 1964 The Hopewell interaction sphere in riverine-western Great Lakes culture history. In Hopewellian Studies, eds J. R. Caldwell and R. L. Hall. Pp. 85-106. Illinois State Museum Scientific Papers no. 12. Springfield.
- 1965 Middle Woodland culture history in the Great Lakes-Riverine area. American Antiquity 31(2):211-223.
- 1968 Woodland Subsistence-Settlement Systems in the Lower Illinois River Valley. In New Perspectives in Archeology, edited by S. R. Binford and L. R. Binford. Pp. 285-312. Aldine Publishing Co., Chicago.
- 1973 Chert utilization in the Lower Illinois valley prehistory. In Variations in Anthropology: Essays in Honor of John C. McGregor, eds. D.W. Lathrop and J. Douglas. Pp. 61-73. Illinois Archaeological Survey, Urbana.
- Styles, Bonnie W.  
1981 Faunal exploitation and resource selection. Northwestern University Archaeological Program, Scientific Papers no. 3. Evanston.

- Styles, Bonnie W., James R. Purdue and Mona L. Colburn  
 1985 Faunal exploitation at the Smiling Dan site. In  
 Smiling Dan, eds. B.D. Stafford and M.B. Sant. Pp.  
 402-446. Center for American Archeology, Kampsville  
 Archeological Center, Research Series Vol. 2.  
 Kampsville.
- Styles, Thomas  
 1985 *Holocene and Late Pleistocene Geology of the Napoleon  
 Hollow Site in the Lower Illinois Valley.* Center for  
 American Archeology, Kampsville Archeological Center,  
 Research Series Vol. 5. Kampsville.
- Tandarich, John P.  
 1976 A cultural resource survey of the proposed site of the  
 Iowa-Illinois Gas and Electric Company power plant,  
 Louisa County, Iowa. Contract Completion Report no.  
 17, Office of the State Archaeologist, Iowa City.
- Theler, James L.  
 1983 *Woodland Tradition Economic Strategies: Animal  
 Resource Utilization in Southwestern Wisconsin and  
 Northeastern Iowa.* Unpublished Ph.D. dissertation,  
 University of Wisconsin-Madison.
- 1986 *The Early Woodland component at the Mill Pond site,  
 Wisconsin.* Pp. 137-158. In Farnsworth and Emerson  
 eds.
- Thies, Randall M.  
 1979 *The Archaeology and Ecology of the Brassica Bench Site  
 (13PK251), Polk County, Iowa.* Masters Thesis,  
 Department of Sociology and Anthropology, Iowa State  
 University, Ames.
- Thorntwaite, C. W.  
 1941 *Atlas of climatic types in the United States.*  
 Miscellaneous Publication 421:1-7. U.S. Department of  
 Agriculture, Washington, D.C.
- Tiffany, A.S.  
 1876 *Prehistoric cremation furnace. Report on the results  
 of the excursion to Albany, Illinois, November 7th and  
 8th, 1873. Mound explorations in 1875. Proceedings of  
 the Davenport Academy of Natural Sciences 1.*
- Tiffany, Joseph A.  
 1974 *An application of eigenvector techniques to the seed  
 analysis of the Brogley rockshelter (47Gt156). The  
 Wisconsin Archeologist 55(1):2-41.*



Tiffany (cont.)

- 1979 An overview of Oneota sites in southeastern Iowa: A perspective from the ceramic analysis of the Schmeiser site, 13DM101, Des Moines County, Iowa. Proceedings of the Iowa Academy of Science 86(3):89-101.
- 1981 The Keyes Archaeological Collection: A Finders Guide. Iowa State Historical Department, Division of the State Historical Society, Iowa City.
- 1982a Hartley Fort ceramics. Proceedings of the Iowa Academy of Science 89(4):133-150.
- 1982b Site catchment analysis of southeast Iowa Oneota sites. In Oneota Studies, ed. G. Gibbon. Pp. 1-14. University of Minnesota Publications in Anthropology no. 1. Minneapolis.
- 1986 The Early Woodland period in Iowa. Pp. 159-170. In Farnsworth and Emerson eds.

Hill, Anton

- 1977 Louisa County archaeology. In Iowa's Great River Road Cultural and Natural Resources Vol. II, by J. Kotopp. Pp. 187-176. Iowa Department of Transportation, Ames.

- Van Dyke, Allen P., David F. Overstreet and James L. Theler.  
1980 Archaeological recovery at 11-RI-337, an early Middle Woodland shell midden in East Moline, Illinois. The Wisconsin Archeologist 61(2):125-265.

Uehik, Susan C.

- 1983 Middle Woodland mortuary practices along the northeastern periphery of the Great Plains: a consideration of Hopewellian interactions. Midcontinental Journal of Archaeology 8(2):211-256.

Walter, N.F., G.R. Hallberg and T.E. Fenton

- 1978 Particle-size analysis by the Iowa State University Soil Survey Laboratory. In Standard Procedures for Evaluation of Quaternary Materials in Iowa. Pp. 61-74. Iowa Geological Survey Technical Information Series No. 8, Iowa City.

Webb, T., and R.A. Bryson

- 1972 Late and postglacial climatic change in the northern Midwest, U.S.A.: Quantitative estimates derived from fossil pollen spectra by multivariate statistical analysis. Quaternary Research 2:70-115.

- Weichman, Michael S.  
1974 An Appraisal of the Archaeological, Historical, and Architectural Resources within the Muscatine Island Levee District Project, Muscatine, Iowa. Report no. 1, Environmental Research Center, Iowa City.
- Weichman, Michael S., and John Tandarich.  
1974 Iowa River Overview. Environmental Research Center, Research Report 10, Iowa City.
- Wendland, Wayne M.  
1978 Holocene man in North America: the ecological setting and climatic background. Plains Anthropologist 23(82)pt.1:278-287.
- Wheeler, Richard  
1952 Plains ceramic analysis: A check list of features and descriptive terms. Newsletter no., 5:29-35. Plains Archaeological Conference.
- White, Anta Montet  
1963 Analytical description of the chipped-stone industry from the Snyders Site, Calhoun County, Illinois. In Miscellaneous Studies in Typology and Classification by A. M. White, L. R. Binford and M. L. Papworth. Anthropological Papers no. 19, Museum of Anthropology, University of Michigan, Ann Arbor.
- 1968 The Lithic Industries of the Illinois Valley in the Early and Middle Woodland Period. Anthropological Papers No. 35, Museum of Anthropology, University of Michigan, Ann Arbor.
- White, John K.  
1985 Ceramics. In Deer Track: A Late Woodland Village in the Mississippi Valley, eds. C.R. McGimsey and M.D. Conner. Pp. 27-43. Center for American Archeology, Kampsville Archeological Center, Technical Report no. 1.
- White, Everett M.  
1983 Geomorphology and soils of the project area, Mississippi River crossing-east loop expansion. In Cultural Resources Survey and Subsurface Testing of the Proposed Mississippi River-East Loop Expansion Project Iowa and Illinois, by L. A. Hannus. Chapter 3. InterNorth Environmental Section.
- Willey, Gordon R. and Phillip Phillips  
1958 Method and Theory in American Archaeology. University of Chicago Press, Chicago.

- willey, Gordon R. and Jeremy A. Sabloff  
1974 A History of American Archaeology. W. H. Freeman and  
Company, San Francisco.
- wolf, Eric  
1982 Europe and the People without History. University of  
California Press, Berkeley.
- wray, Donald E., and Richard S. MacNeish  
1961 The Hopewellian and weaver occupations of the weaver  
site, Fulton County, Illinois. Illinois State Museum,  
Scientific Papers 7(2).
- wright, H.E.  
1968 History of the Prairie Peninsula. In The Quaternary of  
Illinois, ed. R. E. Bergstrom. University of Illinois  
College of Agriculture, Special Publications No. 14.
- Yanovsky, Elias  
1936 Food plants of the North American Indians. United  
States Department of Agriculture Miscellaneous  
Publication 237.
- Yarnell, Richard A.  
1978 Domestication of sunflower and sumpweed in eastern  
North America. In The nature and status of  
ethnobotany, ed. R. I. Ford. Pp. 289-299. University  
of Michigan Museum of Anthropology, Anthropological  
Papers 67. Ann Arbor.

APPENDIX A  
Request for Proposal  
SMS Proposal  
Correspondence

PART I - SECTION C, Description/Specification/Work Statement.

I. OBJECTIVE.

1.1 The following described professional services contract requires the development and execution of a Data Recovery Plan (DRP) for prehistoric sites 13LA30 and 13LA38 located on Federal land for Mississippi River Pool 17 in Louisa County, Iowa. The major work elements under this solicitation are: (1) a comprehensive site-specific literature search with oral interviews; (2) development of a DRP; (3) execution of archeological and geomorphological fieldwork with detailed analysis in support of the DRP; and (4) the preparation of a high quality technical report on the results of field investigations and analysis.

1.2 The Contractor will be required to cooperate through information exchange with the organization conducting a survey for Mississippi River Pool 17 and the organization conducting DRP work for prehistoric site 11HE3 (Putney Landing, Henderson County, Illinois, Mississippi River Pool 18) to ensure the greatest contribution to an understanding of Midwestern prehistory for this portion of the Upper Mississippi River Valley. The Pool 17 survey and the 11HE3 DRP project will be procured under separate advertisements.

1.3 This action is in accordance with the National Historic Preservation Act (as amended in 1980), the Archeological and Historic Preservation Act of 1974, Executive Order 11593, the Archaeological Resources Protection Act (ARPA) of 1979 (as amended in 1984), and Title 36 of the Code of Federal Regulations, Parts 60-66 and 800, as appropriate. An ARPA permit will be issued by the Rock Island District based upon information contained in the successful proposal. Prospective offerors are advised to review this regulation, particularly Sections 6-9, to insure that proposals meet ARPA requirements.

1.4 Development and execution of a DRP is required to mitigate the adverse effects from operation of the Nine-Foot Channel Navigation Project, erosion, vandalism, and substantial losses of cultural deposits. The DRP will be developed by Offerors in the form of a technical proposal. This Scope of Work (SOW) was reviewed by the Iowa State Historic Preservation Officer (SHPO) and the Advisory Council on Historic Preservation (ACHP) prior to advertisement.

1.5 The Contractor shall continue to adhere to the minimum professional staffing requirements set forth in Title 36 of the Code of Federal Regulations. For the most part, these guidelines are compatible with standards set forth by the Society of Professional Archaeologists and standards recommended by the Iowa SHPO. Prospective Offerors also must adhere to the standards for archeology published in the Federal Register by the National Park Service (48:190:4-716-44742). The Contractor shall identify the Principal Investigator

and key personnel in the proposal. The Principal Investigator must be able to document their involvement in the project, and will be responsible for the technical quality of the work.

1.6 The DRP approach is only being undertaken because there is no feasible alternative mitigation strategy for information already lost and for establishing a sloped bank that can be stabilized.

## II. PROJECT BACKGROUND

2.1 On 29 July 1985, the Rock Island District, Corps of Engineers, received an inquiry from Dr. Duane C. Anderson, the Iowa State Archaeologist, concerning a recently exposed portion of previously recorded prehistoric site, 13LA38, near Lake Odessa (Exhibits 1 through 3). Dr. Anderson had received a report from Mr. Jerry Cross of Wapello, Iowa, who reported the possibility that human skeletal remains were being eroded out of the cut bank. Dr. Anderson heads the Office of the State Archaeologist of Iowa (OSA) which is responsible for the disposition of human skeletal remains from archeological sites. Because the site appeared to be on land under Federal jurisdiction, Dr. Anderson requested that Corps staff inspect the site and report the results to OSA and the Iowa SHPO.

2.2 Mr. Charles R. Smith, staff archeologist for the Rock Island District, made arrangements for Mr. Leon Hodges, a ranger from the Lock and Dam 16 Field Station, to visit the site and to contact Mr. Jerry Cross concerning the human skeletal remains. Mr. Hodges confirmed the fact that there was a rich archeological deposit exposed in a cut bank near the low water mark and that collectors were regularly visiting the site. A substantial amount of unidentified bone was reported to be present on the beach below the erosional cut. This information was reported to Dr. Anderson by telephone on 31 July 1985, along with plans for conducting an archeological reconnaissance.

2.3 On 2 August 1985, staff from the Environmental Analysis Branch, Rock Island District, visited the site. Staff members present were: 1) Smith; 2) Mr. Kenneth Barr - archeologist; 3) Mr. Robert Clevestine - biologist; and 4) Mr. Calvin Willingham - biologist. A second visit was made on 7 August 1985 to complete the reconnaissance work at 13LA38 and to examine site 13LA30 across Sand Run Slough. Reports from collectors suggested that the two sites contained similar cultural materials. An examination of available maps revealed the possibility that the two components were part of a single site at the time of occupation. Postsettlement river changes, exacerbated by artificial changes in water levels during the historic period, have bisected the site. The slough separating the two sites is approximately 60 meters wide.

2.4 The dense scatter of materials initially recorded by Mr. Duane Miller and again by OSA as 13LA38 is located approximately 1/4 mile upstream (north) of the cottage area at the Sand Run river access area at approximate river mile 436.5. The site is located in the NW1/4, NE1/4, SW1/4, NE1/4 of Section 33 in T. 74 N., R. 2 W., Louisa County, Iowa. Sand Run Slough is a narrow channel which drains Lake Odessa from its southern extremity into the Mississippi River. The primary surface scatter of site 13LA30 is located across the slough and about 20 meters downstream from 13LA38 in Section 33

(SE1/4, NE1/4, SW1/4, NE1/4). Based upon the ceramics collected from the sites, it appears that they were occupied during the same major subdivisions of the Woodland period.

2.5 The cultural deposits appear to be incorporated into a terrace remnant located beneath a fairly precipitous bluff line. Preliminary geomorphological analysis (Exhibit 4) suggests that the current "A" soil horizon developed in post-settlement colluvium washed down from the uplands. Historic period clearing activities likely are the main cause of this massive reworking of upland soils. Both the "IIA" and "IIIA" soil horizons appear to have been very slowly accreting surfaces during the prehistoric period. No laminae are observable in either horizon, and the quantity of artifacts present would seem to attest to the stability of the landform at the time of occupation. The "C" horizon probably correlates with other early Holocene slack water clay deposits found along the Mississippi River. Two moderately distinct artifact concentrations were noted in the cut bank profile, one apparently corresponding to the Archaic period (120 cm to 180 cm) and a second stratum containing the Woodland occupations (75 cm to 100 cm). These concentrations of chert and pottery were mixed with substantial quantities of fire-cracked rock, charcoal, and burned earth. Several hearth features were noted within the concentrations.

2.6 Summaries of lithic, ceramic, and faunal materials collected from the surface (actually a lag midden 10 cm thick) and from cut bank profiles are presented in tables 1 through 6. Note the substantial quantity of material in the 1-meter square at 13LA38 that was collected by sifting through the midden by hand, piece-by-piece. The density of 330 items (39 ceramic and 291 lithic) per square meter indicates the richness of the deposit. If the same procedure had been used for the entire beach area at 13LA38 (60 m X 5 m) it is estimated that a total of 99,000 items could have been collected. These estimates do not include a complete collection of rough or fire-cracked rock, the predominant material in the midden. Several pieces of quartz and diorite were noted along with granites, basalts, gabbros, schists, and hematites. These rocks were transported to the site by its occupants.

2.7 Four hundred and seventy (470) ceramic sherds were collected from disturbed contexts at sites 13LA38 (N=258) and 13LA30 (N=212). Due to the similarities between the ceramics recovered from the two sites (portions of the same vessel were recovered from each side of the slough), the ceramics are discussed together here. Approximately 66 percent of the combined sample (N=302) is undecorated body sherds with either plain or cord-roughened surface treatment. These are sorted by relative thickness and surface treatment (table 3). The vast majority of these sherds are grit tempered and are probably from Havana Plain and Havana Cordmarked vessels. A more detailed analysis of the body sherds would no doubt result in the identification of types relating to Early and Late Woodland activities at the site. However, due to the disturbed context, no further analysis is warranted at this time. It is intended that the collections will be reexamined by the Contractor performing the data recovery work as part of the detailed analysis and comparison to information derived from undisturbed depositional contexts.

2.8 The ceramics recovered from disturbed contexts at sites 13LA30 and 13LA38 date from the Early Woodland through Late Woodland periods and compare to types previously described for Illinois, Iowa, and Wisconsin. Future research designed to investigate the stratified deposits still intact at the sites could add significantly to our understanding of the relationships that existed between these regions during the Woodland period. For example, researchers could address the question of Illinois-related Middle Woodland ceramics which occur in a number of sites in a line which moves northwesterly across the Mississippi River Valley to sites along the Iowa River and at Coralville Lake, Iowa. Another avenue worth exploring is the emerging pattern of intensively occupied base camps on the floodplain. The intensity of occupation is demonstrated by the abundance of debris left behind, and the variety reflected in the ceramic assemblage.

2.9 Seventy-seven chipped stone tools were recovered from 13LA38. These include a variety of unifacial scrapers (n=21), bifacial tool fragments (n=38) and projectile point/knife fragments (n=17). The tools recovered indicate that a wide variety of functional activities took place at the site. However, because of the disturbed and mixed context that the tools were recovered from, few of the tools can be assigned to cultural periods. Therefore, it is not possible to discern whether the site functioned as a base camp throughout its use from Archaic through Woodland times or if the majority of the tools are from a single major component nested within a series of smaller ones.

2.10 The beaches at both sites were littered with burned rock. Most of the rock is extremely crazed, with reddening or blackening very evident. A small sample was collected for future reference in light of discussions by Van Dyke and Behm (1981), Van Dyke (et al. 1980), and Bettis and Benn (1984) concerning the significance of rough and fire-cracked rock for delineating site limits and determining activities carried out by prehistoric peoples. The substantial amounts of this material support hypotheses for sizeable and frequent roasting activities, and perhaps heat treatment of cherts. Smudge pits may be another possibility.

2.11 A summary of the faunal remains recovered from sites 13LA30 and 13LA38 is presented in table 6. Note that a variety of small and large mammals are represented, along with fish, turtles, and various birds. White-tailed deer was by far the most common species represented in the assemblage. The presence of elk bone smashed open for marrow and coyote-sized dog remains also are of interest. The major point to emphasize here is the fairly good preservation of faunal remains, a characteristic often missing from floodplain sites in the region. The potential for obtaining significant environmental and subsistence data during future excavations appears to be high.

2.12 The sites are not only rich in artifact content, but have portions which are geomorphologically intact. Finely controlled excavations can contribute much to our understanding of local Holocene fluvial history and prehistoric cultural development. Because the deposits are stratified, investigators can address questions concerning ceramic and lithic technology from chronological and typological perspectives in order to clarify concepts of Late Archaic and Woodland manifestations in the Tri-State region. Because of previous losses of site area and contents, archeological testing/data recovery



is the recommended strategy for preserving significant information in the short term. This work will be a part of the Upper Mississippi River Cultural Resources Management Program of the Rock Island District. Work in Mississippi River Pools 10, 11, 12, and 16 in recent years has revealed how little is known about the archeology of floodplain contexts. These investigations have indicated that substantial prehistoric activity occurred in these locations, that the floodplain consisted of vast areas of fairly dry landscape (oak-hickory forests), and that utilization was not limited to short-term/limited function extractive camps.

2.13 Future impacts (vandalism and erosion) warrant a data recovery orientation. The erosional processes of the Mississippi River in backwater channels such as the ones discussed in this report cannot be halted without the expenditure of staff effort and funds that is well beyond that required to address the public interest. The speed at which sites of this nature are lost requires that mitigation of impacts begin with excavations and end with more reasonable efforts to preserve sites which are not immediately endangered. Corps staff will investigate the alternatives for bank stabilization measures to halt further erosional loss. The work at sites 13LA30/13LA38 will proceed in conjunction with archeological/geomorphological surveys of Pools 17 or 18 and excavations at 11HE3, if funding is available. Taken together, the databases derived from these activities should stand as a major advance in Midwestern archeology, and serve as a sound basis for the Corps to make cultural resource management decisions for similar sites pursuant to Sections 106 and 110 of the National Historic Preservation Act, Executive Order 11593, and the Archaeological and Historic Preservation Act.

2.14 PROSPECTIVE OFFERORS SHOULD OBTAIN A COPY OF THE REPORT ENTITLED CULTURAL RESOURCES RECONNAISSANCE AT PREHISTORIC SITES 13LA30 AND 13LA38, SAND RUN SLOUGH, MISSISSIPPI RIVER, LOUISA COUNTY, IOWA. THIS REPORT DETAILS THE ABOVE-REFERENCED RESEARCH AND PRESENTS A PRELIMINARY EVALUATION OF THE SITES AND THEIR CULTURAL CONTENTS WITH MAPS AND ILLUSTRATIONS. THE REPORT ALSO OUTLINES POSSIBLE RESEARCH ORIENTATIONS FOR CONSIDERATION IN DRP DEVELOPMENT.

2.15 By letter dated 10 October 1985, the Iowa SHPO stated that in his opinion the sites are eligible for listing in the National Register of Historic Places. The Rock Island District concurred with this determination by letter dated 1 November 1985 to the Keeper of the National Register of Historic Places. The Keeper determined the sites eligible on 15 November 1985 (Exhibit 7).

### III. SPECIFICATIONS

3.1 Site 13LA38 covers approximately 320 square meters. Site 13LA30 also covers approximately 320 square meters. The cultural deposits at 13LA38 are present to a depth of 2 meters along the cut bank, but may be deeper closer to the slope due to burial by colluvium. The depth of the deposits at 13LA30 has not been determined but should be similar. Offerors must attempt to estimate the percentage of each site that will be investigated under the DRP. Refinement of site limits is expected. Excavations should focus along the riverbank to take advantage of the cut bank profile, to examine the exposed features and to collect data from the area where bank sloping and stabilization may occur. Some work will be required away from the bank to improve the overall understanding of site structure; however, this effort will be of a sample nature as preservation efforts will be attempted.

3.2 Little was done with the large sample of chert debitage (862 items) collected by Corps staff; however, once controlled excavations have been completed, the sample may be of use for comparison with Contractor excavated samples. This site may be a good candidate for testing methods of analyzing mixed assemblages of debitage based upon comparisons to assemblages derived from controlled excavations. Hundreds of sites on Federal land are primarily disturbed and mixed component manifestations. One of the problems shared by the Corps as a land managing agency and the Iowa SHPO as a review and compliance agency, is determining an appropriate treatment for these kinds of sites. In the past, sites of this type have been written off after sample surface collections have been made and the absence of subsurface features has been confirmed. Perhaps lag component materials from sites 13LA30 and 13LA38 can be used to develop procedures for maximizing informational return and for justifying certain kinds of analysis at other disturbed context sites, particularly those where features are not present. The problem of mixed component sites in the Upper Mississippi River Basin is a major problem for the Rock Island District cultural resource management staff and for the profession at large. The Corps is hesitant to ignore what might be a large portion of the extant cultural resource base under its jurisdiction; however, the expenditure of limited Federal funds and staff hours must be justified prior to any recommendation for extensive study of disturbed context sites. The principal investigator will be required to address this problem as part of the overall project. A similar position has been taken by Farnsworth and Koski (1985: 21 and 226) for small upland sites in west-central Illinois. Work at the Massey and Archie Sites as part of the FAP 408 Highway Project demonstrated that substantial amounts of data may be present which, when subjected to detailed analyses, can contribute to the understanding of prehistoric occupations in terms of site function, resource procurement, lithic and ceramic technologies, and settlement patterns. The strong statement for not automatically writing off such small, disturbed sites cogently summarizes concerns held by Corps staff for sites in the Upper Mississippi River Valley (Smith 1985), particularly in terms of the so-called "mundane" but important methodological advancements that can be realized which can improve management decisions District-wide.

3.3 After consulting relevant ceramic typology publications for the lower Illinois River Valley (Fortier et al. 1984; Griffin 1952; Griffin et al. 1970; Munson 1982; and Cole and Deuel 1937), northeastern Iowa (Alex 1980; Benn 1978, 1979; Logan 1976; Van Dyke and Behm 1981; and Van Dyke et al. 1980), and the driftless area of southwestern Wisconsin (Boszhardt and Overstreet 1981; Boszhardt, Theler, and Kehoe n.d.; Logan 1976; Overstreet 1983, 1984, 1985; Stoltman 1979, n.d.; and Theler 1983), decorated body sherds and rims were sorted into currently recognized Woodland types in the Corps report. Various type designations and cultural interpretations have been applied to similar-looking ceramic styles in each of the above geographic regions. Exhibit 5 is intended as a guide for cross-referencing the various cultural phases and ceramic types which appear in the literature. The type names used in the Corps reconnaissance report were selected based predominately on intuitive impressions and are not intended to convey any broad theoretical implications relating to cultural interactions that took place between the bordering regions. The primary objective was to insure that a reasonably accurate preliminary sorting was accomplished. This would facilitate the utility of this report as an attachment to the anticipated solicitation for archeological data recovery at sites 13LA38 and 13LA30. A major problem faced by Federal archeologists is the use of different terms for cultural periods, phases, complexes, and foci dependent primarily upon regional or localized biases. This contract should help clarify the major classifications used for the three primary research areas which border the sites.

illustrated on Exhibit 3, the DRP should address hypotheses concerning prehistoric cultural development in the Upper Mississippi River Valley region as discussed in the Corps reconnaissance report.

3.5 Due to the number of cultural components represented at the sites and the illustrated potential for recovering well preserved subsistence data, the winning contractor is required to show expertise in a number of archeological subdisciplines. These include, but are not limited to faunal and floral, Early, Middle and Late Woodland ceramic analysis, the Archaic period generally, and geomorphology. Because of the potential complexity in each of these areas, a team approach is highly recommended.

3.6 The Contractor shall include provisions for necessary professional level geomorphological studies to identify and define the sequence, depth, and extent of soils development. Geomorphic process and fluvial histories will be required. Of particular concern is the relationship between cultural resources and landforms. The question of what resources have been lost due to erosion and inundation must be addressed, as well as what kinds of resources remain for future management efforts. It is anticipated that geomorphological studies may identify surface and/or subsurface surfaces and landforms which can be defined as contexts likely to contain cultural resources as was done for the downstream corridor at Saylorville Lake, Iowa (Benn and Bettis 1981; Benn and Harris 1983), and for Pools 10, 11, 12, and 16. Prospective contractors are advised to obtain soils and landform maps, as well as maps on file at the Rock Island District.

3.7 In order to attain maximum cost effectiveness for any geomorphological fieldwork that will be performed, the Contractor shall make appropriate use of power machinery for test trenching, test pitting, and coring.

3.8 Resources of the SHPO, Mr. David Crosson, and the State Archaeologist, Dr. Duane Anderson, shall be investigated. The Contractor will be responsible for updating State site forms.

3.9 Written archival sources shall be utilized such as the USGS maps, 19th/20th century plat maps, land holding records, and Rock Island District files. The District has Mississippi River Charts from 1881, Brown's Survey maps from 1930, and hand-drawn plane table maps from 1938 to 1943. The successful Offeror shall be provided copies of these maps, as well as tract maps, for use. Oral interviews shall be conducted with local collectors, property owners, former property owners, and State/local Historical Society members.

3.10 Based upon Sections 3.1 through 3.13 above, the Contractor will provide information for cultural resources management program planning, identifying the following:

a. What data exist, as well as what data gaps exist geographically, temporally, and as guidance for research topics which can be approached through the performance of this and future contracts?

b. What RP3 study needs can be addressed through the performance of this contract?

c. How will data discovered during this contract contribute to our understanding of cultural resources for Pools 17 and 18 and the region (descriptive and interpretive)?

d. How do geomorphological and ecological data apply to cultural resource investigations at sites 13LA30 and 13LA38?

3.11 An explicit research design will be required that provides the rationale, goals, and methods for this investigation including, but not limited to:

a. The scientific and anthropological reasons for pursuing the proposed investigation.

b. What the investigator realistically hopes to determine about past human activity, including such topics as occupational sequences, settlement patterns, subsistence strategies, chronologies, trade and social networks, and geomorphological considerations.

c. What the investigator has learned concerning "b" above using the data actually generated under this contract.

d. The explicit manner in which data will be collected and analyzed, and how these relate to the research goals and results.

e. Geomorphic field strategies that were applied and their utility.

f. Descriptive analytic and interpretive techniques should be presented, including summaries of classification systems used.

g. Quantitative techniques used to interpret data shall be explained.

#### IV. PROPOSALS

4.1 The Contractor shall submit a technical proposal in the form of a DRP (Research Design). This plan shall be designed to make the greatest contribution to an understanding of Midwestern prehistory. The Contractor shall fully consider all extant documents relating to the development of Resource Protection Planning in the State of Iowa.

4.2 The DRP shall specify the following:

a. What research questions shall be investigated.

b. What kinds of data shall be collected to answer "a" above.

c. What methods shall be used for data recovery and what sampling procedure will be used.

d. What types and levels of analyses will be conducted.

e. What data may be lost or deemphasized as a result of "a" and "b" above.

f. How the data recovery plan will address Iowa RP3 topics (Elizabeth Henning 1985).

These are considered the minimum topics that must be addressed. The DRP is expected to go beyond them and must be as specific and detailed as the existing data allow.

4.3 Laboratory procedures shall be described in the DRP, particularly those which require use of consultants for special studies such as faunal, floral, pedological, and C-14 analyses.

4.4 In addition to the technical proposal, a separate cost proposal must be submitted to the Contracting Officer for evaluation. The cost proposal will be a detailed, itemized quotation for personnel, goods, and services needed to accomplish the technical proposal.

4.5 The Contractor shall conduct this investigation in a manner that insures the greatest contribution to an understanding of Midwestern prehistory and history. In an effort to insure this, prospective principal investigators shall submit a technical research proposal and a separate cost proposal to the Contracting Officer for evaluation. The technical proposal shall include sufficient discussion to fulfill the Scope of Work and how these needs will be met. Key personnel will be identified and manpower efforts (by hours) shall be included but without costs. The cost proposal will be a detailed, itemized quotation for personnel, goods, and services required to accomplish the technical proposal. Overhead and wage rate figures shall be clearly presented, as well as any costs for equipment, transportation, per diems, lodging, and consultant services. The cost proposal shall be sealed in a separate envelope to insure that the technical evaluation can be accomplished without prejudice prior to evaluating cost proposals.

4.6 The technical evaluation team will evaluate the technical proposals first without prior knowledge of the concurrently submitted cost proposals. Therefore, it is in the best interest of the Offeror to include the data necessary to evaluate the merits of technical proposals, independent of cost considerations. Proposals must demonstrate that the Offeror is knowledgeable of previous work in the region, current research objectives, and state-of-the-art methodologies and techniques. Proposals that simply restate the Scope of Work may be judged technically inadequate. A clear, well written, well thought-out research design is far more effective than fancy packaging and pages of stock text on the Offeror's abilities.

4.7 Particular emphasis in proposal evaluation will be given to proposals offering a high quality product which will best accomplish the project goals. (See SPECIFICATIONS, page 11 of this RFP.) Offerors should submit a comprehensive scheduling plan to document anticipated levels of effort per task and to provide this District with a monitoring schedule for contract performance. Contract award will not necessarily be based upon low estimated price, but on the most advantageous combination of method, price, and schedule that best meets the Government's needs. This will be a firm-fixed-price-negotiated contract. However, note that award may be made without negotiation if a competitive pool of proposals is received that can be awarded without modification or clarification. The objective is to obtain the maximum amount of useful information in the most cost-efficient manner.

4.8 Offerors are invited in their proposals to suggest improvements on the Scope of Work so long as the minimum requirements are met. Any substantive changes will be dealt with during the negotiation (best and final) process for those within the competitive range. The objective is to obtain the maximum amount of useful data in the most cost-efficient manner. Note that award may be made without negotiation if a competitive pool of proposals is received that can be awarded as is.

4.9 Laboratory procedures shall be described for special studies such as soils and C-14 analyses. Prospective contractors shall include in proposals a discussion of the capabilities and facilities to adequately perform required laboratory analyses and for curation upon the completion of the project.

4.10 Remote sensing applications should be described, if proposed, particularly in terms of the data sought and the efficiency of the application in relation to traditional collection procedures.

## V. REPORT

5.1 Report. The principal investigator shall be responsible for preparing a comprehensive technical report on the results of this investigation. This report will be in the format described in Exhibit 6 (attached). Basic data description, including provenience and metrics, photographs and drawings, will be provided for use both in support of the author's arguments and conclusions, and as a source of basic information that may find wider use by other archeologists as well as the Corps of Engineers.

5.2 Six copies of the draft report shall be submitted to the Contracting Officer for review 122 days after work begins on the contract (142 days after award). Draft reports shall be complete when submitted, unless other arrangements are made with the Contracting Officer, no less than 30 days prior to the due date. Changes directed by the Contracting Officer based upon draft review shall be made prior to submission of a final report. In the event that major revisions are required, the Contracting Officer may request, and the Contractor will supply, a revised draft report for review at no additional cost to the Government. In the event that a revised draft is required, it will be due 30 days after notice of the Contracting Officer. The final version will be due 30 days after the Contracting Officer approves the draft.

5.3 The draft review period may be as long as 60 days. The intervening time is necessary to obtain reviews from the State Historic Preservation Officers, the District, and the National Park Service (Interagency Archeological Services).

5.4 Any materials (documents, artifacts, or notes) collected under this contract shall be evaluated, analyzed, and referenced according to current professional standards for presentation in the report. These procedures must be specified in proposals. An inventory of these materials shall be supplied to the Contracting Officer with the final bill, as they remain Government property and are subject to review or recall at any time.

5.5 The Contractor shall furnish the Contracting Officer with thirty (30) copies of the final document, including all photographs and appendixes. A master copy of the final report in reproduction format will be furnished to the Contracting Officer with the final bill.

5.6 The Contractor will prepare an informational report on this work suitable for presentation to the lay public. This report should focus on the general prehistory and history of the area, the work done under the contract, and what has been contributed to our understanding of the area. Appropriate photographs, maps, or drawings shall be included to illustrate the project. A set of 35 mm color slides shall be provided to complement the text.

5.7 Prior to acceptance of the final reports by the Government, neither the Contractor nor their representatives shall release any information or materials of any nature obtained or prepared under contract without prior approval of the Contracting Officer. After acceptance of the final reports, their reproduction and use shall not be restricted by either party. Appendixes not intended for public release are identified in Exhibit 6.

#### VI. SCHEDULE

6.1 The overall contract period is 234 days. The Contractor will have up to 20 days after award to initiate the contract work. A schedule, in calendar days, is provided below for guidance:

Award	day 0
Startup	days 0-20
Literature Search/Fieldwork	days 21-51
Literature Search/Analysis	days 52-142 (draft due)
Draft Review	days 143-203
Final Report Submission	days 204-234

234 total days

This information is provided to guide Offerors in proposal preparation. Prospective Offerors may alter the fieldwork and analysis days, as appropriate, to carry out their proposals as long as the overall contract period does not change. Earlier startup times are also acceptable, however, if an award is made during the winter this built-in waiting period should be sufficient to allow the Contractor to wait for acceptable weather. Little, if any, billable work is anticipated to be required during the 60-day draft review period.

#### VII. CURATION

7.1 Any artifacts or cultural materials collected and any notes, photographs, or other data generated during the performance of contract services shall be curated with the Principal Investigator for preservation upon the discretion of the Rock Island District and the respective State Historic Preservation Officers. Successful Contractors outside of the State of Iowa may be required to move these materials to the approved curation facility at OSA. All of these materials remain the property of the Government and shall be made available upon request by the District for interpretive programs, additional research purposes, or any other reason approved by Rock Island District. All data generated under this contract will be curated in one place. It is the Contractor's responsibility to safeguard all of this material and to provide an inventory or catalog system to facilitate access. Copies of any inventories shall be submitted to the Contracting Officer with the final bill.

#### VIII. COORDINATION

8.1 Continuous coordination will be maintained with the appropriate State Historic Preservation Officers and the Rock Island District staff archeologist. Evidence of this coordination will be documented in the draft and final reports.

8.2 Monthly Progress Reports shall be submitted to the Contracting Officer by the 10th day of each month. This report will indicate specific activities and accomplishments during the preceding month and show any scheduled tasks for the following month. These reports will be used by this District to keep abreast of contract progress and to serve as a vehicle for identifying problems with performance of the contract or with significant cultural resources.

IX. GENERAL

9.1 Any arrangements for ingress or egress over non-Federal lands shall be the responsibility of the Contractor. The Contractor is responsible for obtaining permission from any landowners prior to trespass.

9.2 The Contractor will keep District staff informed as to where the work is being conducted and supply names of all field personnel. This contract will be managed by District Archeologist Charles R. Smith, Environmental Analysis Branch, Planning Division, Rock Island District, Corps of Engineers. The phone number is 309/788-6361, Ext. 349. The Contracting Officer's Representative shall be J. P. VanHoorebeke. While routine informational matters will be handled by C. Smith, all bills or contracting matters should be sent in writing to J. P. VanHoorebeke.

9.3 Payments shall be made through receipt of Contractor's billing invoices. Each payment request will be audited by District staff to insure that sufficient progress has been made in support of the bill. As a guideline, the payment schedule listed below shall be used. Recognizing that there is great variability in billing procedures, fractional amounts will be accepted; however, adherence to the schedule is preferred.

Completion of Documentary Work	20% of contract amount
Completion of Fieldwork	40% of contract amount
Completion of Analysis	60% of contract amount
Receipt of Acceptable Draft Report	70% of contract amount
Approval of Draft Report	80% of contract amount
Receipt of Final Reports	90% of contract amount
Receipt of Final Bill, Inventory Sheets, Reproduction Format Master	100% of contract amount

The Contracting Officer may approve payment for higher percentages than those shown in the above schedule if an appropriate amount of work can be identified as having been accomplished.



PROPOSAL FOR  
DATA RECOVERY AT SITES  
13LA30 & 13LA38, LOUISA COUNTY, IOWA

by David W. Benn  
Principal Investigator  
Center for Archaeological Research  
Southwest Missouri State University  
Springfield, Missouri 65804

7 February 1986

This is a research design for data recovery at two sites, 13LA30 and 13LA38, in Louisa County, Iowa. The purpose of the project is to mitigate impacts caused by operation of the Mississippi River navigation channel on the two sites, which have been determined eligible for the National Register of Historic Places. By making this proposal the principal investigator and the Center for Archaeological Research agree to comply with all stipulations and products indicated in the COE Request for Proposal No. DACW35-86-R-0014.

This presentation is divided into three parts. First, assumptions that will influence the writer's approach to the project are discussed. Secondly, four groups of research problems are developed for testing during the project. In the last part the methodology, scheduling and personnel in the project are described.

#### Assumptions

All archaeologists bring their preconceptions and personal biases (interests) into research projects. The funding and scope of a project, as proposed by the client agency, also impose limitations on the research plan. The most important constraints and preconceptions foreseen for this data recovery project are described below.

- a) Physical constraints in the sites. The two impacted sites have uncertain dimensions extending away from the river banks. However, direct impacts in the form of bank erosion are limited to linear areas of the sites along the slough. These narrow impact zones will be the focus of most of the research effort, and large portions of both sites will not be investigated. Additionally, dense vegetation on 13LA38 and a shallow water table in both sites will complicate the excavation procedure. One goal of the project must be to utilize in the most economical manner hand testing, backhoe trenching and solid core drilling to determine the sites' parameters beyond the loci of excavation blocks.
- b) Limitations of geoarchaeological interpretation. One critical component of the project will be geomorphological and pedological studies that will place the cultural deposit in its depositional context. But, there are inherent limitations in the interpretive potential of data from a single

limits of study. As Bruce Gladfelter put the issue somewhat conservatively, "Archaeological settlement in (floodbasin) settings can not properly be understood or correlated by an examination of the geostratigraphy at a single site; and...definitive interpretation of site-situation should neither be suggested nor inferred" if the investigations do not have an appropriately wide scope (1985:42). Because the fluvial system of the Mississippi River dwarfs the study area in question, we can hope at best to demonstrate that there are significant relationships between the context of 13LA30-38 and models of the floodplain such as Church (n.d.) and Gladfelter (1981).

- c) Cultural interpretations. The impacted sites will yield huge amounts of well preserved cultural data which will add substantially to knowledge about prehistoric cultures. However, the proposed excavations will sample only a small part of the sites, and both sites represent only a tiny portion of the vast cultural record in the Upper Mississippi Basin. It is certain, therefore, that cultural interpretations relating to a regional context and chronological sequence of cultures (i.e. synchronic and diachronic dimensions) must be constrained within a finite number of research problems. Otherwise, funds for the project will be ineffectively dissipated among divergent goals.

## Research Problems

There are four areas of research that can be appropriately fitted into the mitigation of 13LA30-38 with the amount of funding that is available and in consideration of the limitations described above. The writer considers these four areas to be the minimum of research that will be accomplished on both sites. The four research topics are inclusive of all suggested research problems presented in the COE Request for Proposals. When the fieldwork is finished, other avenues of research will open because of unanticipated findings.

### Topic 1

#### Geomorphic/Pedogenic Contexts

The descriptions and maps in the 13LA30-38 reconnaissance report (Corps of Engineers 1985) show that both sites are situated on floodplain terraces separated by Sand Run Chute (Muscatine Slough). Site 13LA38 is on the west bank in the foot/toeslope position beneath the bluff, while 13LA30 is in accretionary deposits of the floodplain on the east bank of the slough. If the slough has been in this position for a long period of time, then the sites are on landforms with different constructional histories because their local sources of alluvium are different. (A recent date for cutting of the slough would mean that a single site on one terrace has been sliced into two fragments, resulting in a substantial loss of information and site context.) Church (n.d.:41) and Gladfelter (1985:47) have found that the Mississippi River meanderbelt and many of its channels have been remarkably stable during the late Holocene period (ca. 4000 B.P. to present). This information supports the contention that some channel (now called Sand Run Chute) has been active while the terraces at both sites were constructed.

An adequate research design for the 13LA30-38 project must be able to investigate the most complex of the alternative constructional histories like the two described above. The research design also must produce a detailed natural stratigraphy for the contexts of all cultural materials. The following specific research problems are presented to fulfill these needs.

- 13) In the foot/slope position of 13LA38 the terrace is subject to alluvial deposition from several sources: channel sands, overbank deposits, colluvium from the bluff and alluvium from the nearby fan (to the south). Bank profiles in the COE reconnaissance report (1985:Plate 7) clearly indicate stratigraphy that varies horizontally (e.g. superposed soils, channel sediments, colluvium). The presence of superposed soil horizons and colluvium suggests that this terrace is primarily a vertical accretion deposit, yet its internal stratigraphy varies within a few meters due to the existence of channels and localized sources of sedimentation. Church's preliminary assessment of vertically accreted terraces (n.d.:48), especially those at the base of the bluff, is that they may contain an earlier record of Holocene sedimentation (and therefore cultural record) than the floodplain terraces.
- 14) Site 13LA30 is on a floodplain terrace where the sources of alluvial sediment are limited to channel bar formation and overbank deposits. This terrace is more likely to have been constructed from laterally accreted sediments capped by vertically deposited silt. Church (n.d.:49) predicts that lateral accretion terraces in the meanderbelt formed during the late Holocene period, their edges being younger than the interior island deposits. Archaeological site 13LA30 is at the edge of the island-terrace. Therefore, it is hypothesized that the sediments at 13LA30 and 13LA38 will contain different cultural records (although not necessarily non-contemporary) because the terraces have different constructional histories.
- 15) Given the potential complexity of the landforms in the project area, no successful archaeological excavation can be undertaken without a detailed knowledge of the natural stratigraphy: i.e. horizontal and vertical variations in soil horizons (colors, textures, structures), fluvial features, and orientations of strata. Terraces contain subsurface features that bear no relationship to surface appearances; the same can be true for cultural deposits in those terraces (cf. Overstreet 1984; Pettis and Benn 1984; Benn 1986). An excavation of 13LA30-38 that treated vertical stratigraphy in arbitrary 10cm units would inevitably cross-cut cultural stratigraphy and yield little more than the products from past excavations in middens of mixed components. On the other hand the excavation, being proposed herein, that distinguishes natural units of undulating deposits at the micro-stratigraphic level would likely result in separations of actual cultural components--a superior product for undertaking studies in settlement patterns and culture process.

### Topic 2 Cultural Inventory

Picks, bone tools, ceramics and chipped stone items from both sites are likely to relate closely to documented artifact types from the Mississippi and

Illinois River basins. One basic activity of the proposed project will be to identify artifact types in the site collections and to relate the types to regional cultural systems and to existing artifact sequences. Irregular rocks and many bone and stone tools may not have regional significance but can be analyzed for their function. Specific research problems relating to these pursuits are described below.

- 2a) The pottery classifications will involve several current issues that may be resolved by the large 13LA30-38 collections. The earliest ceramic technology may be represented by examples of Marion Thick. Good examples of this ware have appeared once in northeast Iowa (Logan 1976) and would be a welcome discovery in Louisa County. The problems of Early Woodland pottery classifications will be analyzed. Specifically, the attributes on 13LA30-38 ceramics will be compared to Black Sand Incised, Spring Hollow Incised and to material from farther north in the basin (e.g. Van Dyke and Behm 1981) and in the central Des Moines River valley (Benn and Rogers 1985) in an effort to settle issues of continuity in this ceramic tradition. The relationships to Morton types also will be considered, since this problem relates to the larger question of the origins of Middle Woodland cultures (Munson 1982).

With regard to Middle Woodland (Havana) and early Late Woodland (Linn) potteries, there exist several studies to which the 13LA30-38 types can be directly related (e.g. Griffin 1952; Loy 1968; Logan 1976; Benn 1978; Stoltman 1979). Aspects of interest in the sites' collection of Linn ware are: how far south does this ceramic tradition extend, and is an incised decorative type present in this ware? (The latter issue has been alive in Iowa for decades in the form of Spring Hollow Incised.)

The cord decorated potteries of the Late Woodland period need to be completely analyzed and given type names. The important problems in cord decorated potteries are the proper separation of Madison and Minotts types, the need for a definitive description of Minotts ware and documenting the relationships between the pottery types in Iowa and Maples Mills in Illinois (cf. Riggle 1981).

Finally, any pottery types associated with post-Woodland occupations of the sites need to be recognized and placed in a cultural context. For instance, a handful of Oneota sherds often appear in Woodland site collections; the question is why?

- 2b) At present the use of chipped stone tools as indicators of cultural affiliation and chronology is uncertain in eastern Iowa. Formal chipped stone tools, such as projectile points, knives and shaped scrapers, need to be typed and associated with the ceramic complexes. The projectile point sequence for Late Archaic through Late Woodland periods needs to be defined better for the eastern Iowa region, and other formal types of chipped stone tools must be placed with the point sequence to expand the range of culturally diagnostic tools.
- 2c) Studies of chipped stone, cobble tools and lithic debitage need to incorporate use-wear analyses to determine tool functions. Tool functions should then be related to faunal and floral remains from the

sites to insure a full interpretation of site functions and cultural processes.

- 2d) The RPS study units for the Eastern Woodlands Late Archaic and Mississippi Basin Woodland (E. Henning 1985:26, 37) need to have more robust definitions. The Late Archaic study unit suffers particularly from lack of evidence. Additionally, the artifact inventory and chronology of the Late Archaic must be compared with new information from studies in Illinois (e.g. Brown and Vierra 1983; McElrath et al 1984).

### Topic 3

#### Resources, Subsistence & Setting

New information about Archaic and Woodland subsistence and settlement patterns in the Mississippi valley is being published at a rapid rate (e.g. Stoltman 1983; Theler 1983; Fokken and Finn 1984; articles in Bareis and Porter eds. 1984). Some studies are so recent that a wide ranging literature review will be necessary to update interpretations for the 13LA30-38 project. The recent investigations present hypotheses that are still "green," i.e. they have not been critiqued in print by other authors. This is the case for the deluge of information and ideas in the FAI-270 project (Ibid.). The investigations done in the Prairie du Chien locality (Stoltman 1983; Theler 1983) offer insights into the development of Woodland subsistence and settlement systems which may be compared against the 13LA30-38 data. But, more recent geomorphic work in the Upper Mississippi basin (Church n.d.; Overstreet 1984) indicate that the Late Archaic evidence has not been adequately sampled because much of it is buried in the floodplain. Some directions for problem-oriented research in the proposed project are described below.

- 3a) Studies of raw stone materials, their natural outcrops and uses in chipped stone tools, often provide evidence about the movements and relationships of prehistoric peoples. Among components, shifts in the directions and distance of the origins of raw materials may indicate changing culture patterns and/or site functions. Identification of the lithic materials at 13LA30-38 also will add to an existing data base being accumulated by Toby Morrow (1984) in the State of Iowa.
- 3b) The species composition and association of faunal and floral remains in each of the 13LA30-38 components will be important indicators of site functions and human preferences for food and shelter and social organization. The mere fact that elk (a prairie animal) and fish (a floodplain resource) occur together in the site, but mussels are not common in the midden, suggests some procurement strategies were operating beyond the theoretical notion of catchment basin. These types of resource preferences must be correlated with the artifact inventories, chert types and midden features to achieve a total picture of the subsistence economy. From this information it will be possible to launch into interpretations about site functions: e.g. base camp, extractive site, length of occupation, etc.
- 3c) It will be interesting to see if a shift in subsistence/settlement patterns can be detected between the Archaic and Woodland components, or

if these periods show continuity of a basic floodplain adaptation. Here is an instance where geomorphic analysis of the landform context for the site will be a critical element in the fieldwork. This is because relative rates of sedimentation must be estimated prior to determining the lengths of occupation for each cultural component.

#### Topic 4 Cultural Resource Management

Each instance of site testing and data recovery offers the opportunity to evaluate archaeological methods and procedures. In the case of the 13LA30-38 project this opportunity is doubly significant. The sites are on terraces, an extremely complex landform that archaeologists are beginning to understand through drilling, trenching and hand excavation (cf. Gladfelter 1985; Church n.d.; Bettis and Hoyer 1986; Benn 1986). Secondly, the project is important because the sites are examples of many floodplain sites presently being damaged by the actions of the Mississippi fluvial system and related human development (cf. Overstreet 1984; Johnson et al 1985). One of many ways the proposed project will assist in managing other site impacts is determining the orientations of 13LA30 and 13LA38. The reasoning is this. Landforms in the Mississippi River floodplain form parallel to the flow of water; thus, levees, channel bars, islands, etc. tend to be linear and to occur in laterally accreted bands. Prehistoric humans might be expected to have occupied the better drained linear rises in the floodplain; therefore, site scatters should be linear. We need to know if renewed erosion of a site by a river channel has a greater impact on linear site scatters along channel banks than on round scatters.

#### Research Design

The presumption of this project is that natural formation processes of the fluvial system are independent of human activities; thus, the preservation of evidence at 13LA30-38 depended on the processes of alluviation. The appropriateness of the field methodology has profound effects on the quality of subsequent data analyses and cultural interpretations. This means that the natural terrace stratigraphy at 13LA30-38 must be analyzed prior to undertaking block excavations in cultural components. Basic subdivisions in the sites will be natural stratigraphic units that are divided further into cultural and/or arbitrary levels and horizontal units.

#### field methods:

Preparation for the fieldwork will include obtaining appropriate maps from the COE for the purpose of delineating changes in channels and terraces that have occurred in the last century. COE artifact collections also will be secured to begin assessing what cultural components are present. At this writing it is projected that about three-quarters of the field resources will be expended on 13LA38 and the other quarter on 13LA30. Site 13LA38 is more accessible for bank profiling and machinery and is more susceptible to damage by erosion.

During the initial week of fieldwork an axis of grid stakes tied to a permanent datum will be set on each site for horizontal control. A bench mark above the terrace will be employed for elevations. The next activity on the site will be obtaining surface collections from the shoreline. The shore will be divided into 10m running segments for control, and diagnostic pottery and chipped stone tools will be raked and picked from the deposits. Concurrent with this activity, a transect of solid cores will be drilled across both terraces to expose the deep stratigraphic record.

When the shore has been surface collected, work will begin on profiling representative sections of the 13LA38 bank along its entire length. Accessible parts of the 13LA30 bank also will be profiled. At the same time a backhoe will be employed to cut approximately four narrow trenches in 13LA38. One trench will transect the terrace (perhaps in segments) in an east-west direction from the bank to the bluff base. This will be the primary stratigraphic profile that complements the north-south bank profile. Three other short trenches will be cut east-west to provide vertical profiles for future excavation blocks. (Cutting one or more of the three short trenches might be delayed until preparations are complete for the block excavations.) Positioning of the backhoe trenches will depend on findings from the surface collection and bank profiles. Trench and bank profiling, and stratigraphic and soils descriptions will be done by the writer and E. A. Bettis, the geological consultant. Concurrent with the trenching, a crew person will excavate one meter test units in both sites to probe cultural components that might occur away from the bank exposures. (Site testing in isolated units will be pursued through the period of fieldwork to obtain a complete picture of site stratigraphy.) A line of test units will be excavated perpendicular to the bank on 13LA30 to expose horizontal stratigraphy.

Machine trenching that destroys small parts of an undisturbed site is defended for its long-term advantages and efficiency. The only way to gain access to detailed, vertical profiles of the terrace stratigraphy is to open trenches. Trenching by hand so that cultural artifacts are recovered would be too costly for the type of project being requested by the COE. Furthermore, artifacts from a trench are difficult to associate precisely with undulating stratigraphy that is being exposed at the same time.

After the initial week of fieldwork the testing results will be returned to the laboratory for preliminary assessment. Soil samples from terrace profiles will be sent to a commercial laboratory for analysis. Stratigraphic profiles will be inked and correlated. Material recovered from the shoreline and from excavated test units will be processed and perused to determine artifact patterns in the sites. This interim between field sessions will be 1-2 weeks depending on weather conditions, Mississippi River water levels and the logistics of organizing the field party.

The main term of fieldwork will be five weeks when block excavations are opened to excavate completely through the cultural deposits. Two blocks 2x5m or larger will be excavated along the bank in 13LA38, and a similar sized block will be excavated in 13LA30. Horizontal size of the blocks will depend on potential depth of the deposits and constraints due to ground water. The blocks on 13LA38 will be enclosed for stratigraphic controls on three sides by the vertical profiles in trenches and the river bank. Hand shovelling will be employed to excavate through sterile deposits; otherwise all excavation will

be by hand trowelling. Excavated soil will be dry screened through one-quarter inch hardware cloth, although if time and conditions permit the excavated soil may be water screened through window screen (1/16in). Artifact proveniences will be maintained in one meter horizontal units, and vertical controls will be 10cm arbitrary levels within natural levels. All artifacts associated with features will be piece-plotted. Features will be cross-sectioned and their entire contents retained for processing by floating and water screening. The main excavation blocks will be excavated through the lower (Archaic) components to the water table. Using a pump, attempts will be made to excavate test units below the water table to search for deeper cultural components. A complete written and photographic record of field investigations will be maintained.

informational visits:

It is expected that professional archaeologists and geologists and other persons will visit the site during the excavation. The professional community in Iowa and the COE will be notified in advance when the trenches are open for inspection and study. Trips to other locations in the region also may be organized to study site contexts.

laboratory & personnel:

The writer will function as principal investigator, field supervisor and author/editor of the report for the project. Benn also will work with E. A. Bettis III on the geomorphic/pedological studies.

Material from the excavation will be processed by the regular laboratory technician, Patsy Corbett, in Springfield, Missouri. All diagnostic material will be catalogued and sorted for distribution to specialists. Fragile materials (e.g. mussel shell, fragile bones) will be stabilized. The process of floating soil samples will include chemical flocculation if necessary. When studies are finished, the collections and records can be curated at the CAR or can be sent to a repository in Iowa.

The services of specialists in three sub-disciplines have been secured to analyze part of the collections (see attached vitae). Ms. Lucretia Kelly (R.R., Columbia, IL) has agreed to analyze the faunal remains, for which 150hrs. have been budgeted. Dr. Neal Lopinot (St. Louis) will analyze the paleobotanical remains in 15-20 flotation samples. David G. Stanley (Highlandville, IA) has been budgeted 100hrs. to analyze the chipped stone materials in terms of typologies and use-wear. All three specialist will produce written reports of their analyses, which will be integrated and summarized by the writer. All other material analyses, the discussion of site contexts and the cultural interpretations will be done by the writer during a period of 400hrs. Materials for dating will be sent to Beta Analytic, Inc. or Coral Gables, FL. The services of PIC Consultants (Des Moines, IA) will be retained to provide a drilling machine.



scheduling & reporting:

The writer is prepared to carry out the proposed project within the allotted time of 234 days. One would normally anticipate starting the field season in southeast Iowa by April 1. The initial week of testing should be completed during April, and the excavation should be completed by the end of May. Laboratory work would require approximately one month overlapping with the latter portion of the fieldwork. Collections will be distributed to sub-contractors in June and their reports returned later in the summer for collation by the writer.

Two circumstances could interfere with the scheduling proposed above. Spring rains and high river levels are likely to cause delays in the fieldwork, and it is always uncertain how water delays will affect the overall project schedule. The second mitigating circumstance would be that too much material is recovered from the site, resulting in an extension of the period for analysis and report production within the contract period of 234 days.

The draft report will conform to the stipulations in the Request for Proposals. Besides including a description of all work and findings on the site, the special studies will be incorporated into the writer's interpretations to make the analysis inter-disciplinary. The report also will include a catalogue of all materials by provenience. The ceramic analysis by the writer will be a special feature of the report. Benn will travel to Iowa City to study collections of Minotts pottery housed in the State Historical Society. Collections obtained from the recent Michaels Creek study (Fokken and Finn 1984) also will be analyzed. The writer has accumulated an array of statistical data on cord decorated potteries during a decade of travels throughout Iowa, and this information will be employed to study the materials from southeast Iowa.

## References Cited

- Bareis, Charles J., and James W. Porter eds.  
1984 American Bottom Archaeology. University of Illinois Press, Urbana.
- Benn, David W.  
1978 The Woodland ceramic sequence in the culture history of northeast Iowa. *Mid-Continental Journal of Archaeology* 3(2):215-283.  
1986 Site Testing for the Interpretive Cultural Overview, Saylorville Lake, Iowa. Center for Archaeological Research Project 627-III. Springfield.
- Benn, David W., and Leah D. Rogers.  
1985 Interpretive Overview of Cultural Resources in Saylorville Lake, Iowa. Center for Archaeological Research Project 627-II. Springfield.
- Bettis, E. Arthur III, and David W. Benn.  
1984 An archaeological and geomorphological survey in the central Des Moines River valley, Iowa. *Plains Anthropologist* 29(105):211-227.
- Bettis, E. Arthur III, and Bernard E. Hoyer.  
1986 Late Wisconsinan and Holocene Landscape Evolution and Alluvial Stratigraphy in the Saylorville Lake Area, Central Des Moines River Valley, Iowa. Iowa Geological Survey, Iowa City.
- Brown, James A., and Robert K. Vierra.  
1983 What happened in the Middle Archaic? Introduction to an ecological approach to Koster site archaeology. In *Archaic Hunters and Gatherers in the American Midwest*, eds. James L. Phillips and James A. Brown. 165-195. Academic Press, New York.
- Church, Peter E.  
n.d. The archaeological potential of Pool no. 10, Upper Mississippi River: a geomorphological perspective. US Army Engineers Waterways Experiment Station, Vicksburg.
- Corps of Engineers.  
1985 Cultural resources reconnaissance at prehistoric sites 13LA30 and 13LA38, Mississippi River Sand Run Slough, Louisa County, Iowa. Rock Island.
- Fokken, Michael J., and Michael R. Finn.  
1984 Iowa's Great River Road, Louisa County. The Cultural Resource Group, Louis Berger & Associates, Inc., East Orange, N.J.
- Gladfelter, Bruce G.  
1981 Investigations at the Labras Lake Site, volume III: geomorphological observations in the vicinity of the site. Department of Geography, University of Illinois, Chicago.

Gladfelter (cont.)

1985 On the interpretation of archaeological sites in alluvial settings. In Archaeological Sediments in Context, eds. Julie K. Stein and William R. Farrand. 41-52. Center for the Study of Early Man, University of Maine, Orono.

Griffin, James B.

1952 Some Early and Middle Woodland pottery types in Illinois. In Hopewellian Communities in Illinois, ed. Thorne Deuel. 95-129. Illinois State Museum Scientific Papers no. 5. Springfield, Illinois.

Henning, Elizabeth R.P.

1985 Initiating the Resource Protection Planning Process in Iowa. Iowa State Historical Department, Office of Historic Preservation. Des Moines.

Johnson, Roger D., et al.

1985 Cultural resources investigation for 17 public recreation areas, Navigation Pools 13-24, Mississippi River, Iowa, Illinois and Missouri. Contract Completion Report 217, Office of the State Archaeologist of Iowa, Iowa City.

Logan, Wilfred D.

1976 Woodland Complexes in Northeastern Iowa. Publications in Archaeology 15, National Park Service. Washington, D.C.

Loy, James D.

1968 A comparative style analysis of Havana series pottery from two Illinois valley sites. Hopewell and Woodland Site Archeology in Illinois. 129-196. Illinois Archaeological Survey Bulletin 6, Springfield.

McElrath, Dale L., et al.

1984 Late Archaic period. In American Bottom Archaeology, eds. Charles J. Bareis and James W. Porter. 36-58. University of Illinois Press, Urbana.

Morrow, Toby.

1984 Iowa Projectile Points. Special Publication, Office of the State Archaeologist, Iowa City.

Munson, Patrick J.

1982 Marion, Black Sand, Morton and Havana relationships: an Illinois valley perspective. The Wisconsin Archeologist 63(1):1-17.

Overstreet, David F.

1984 Archaeological Reconnaissance Survey of Pool 10, Upper Mississippi River, Grant and Crawford Counties, Wisconsin, and Allamakee and Clayton Counties, Iowa. Great Lakes Archaeological Research Center, Wauwatosa.

Riggle, Stan.

1981 The Late Woodland Transition in the central Mississippi valley: AD 700-1100. South Dakota Archaeology 5.

Stoltman, James B.

1979 Middle Woodland stage communities of southwestern Wisconsin. In Hopewell Archaeology, eds. David S. Brose and Naomi Greber. 122-139. Kent State University Press, Kent.

1983 Ancient peoples of the Upper Mississippi River valley. In Historic Lifestyles in the Upper Mississippi River Valley, ed. J. Wozniak. University Press of American, New York.

Thelen, James L.

1983 Woodland Tradition Economic Strategies: Animal Resource Utilization in Southwestern Wisconsin and Northeastern Iowa. Unpublished Ph.D. dissertation, University of Wisconsin-Madison.

Van Dyke, Allen P. and J. A. Behm.

1981 Archaeological recovery at 11-RI-217, an early Middle Woodland site at Milan, Illinois. The Wisconsin Archeologist 62(3):257-345.



REPLY TO  
ATTENTION OF

DEPARTMENT OF THE ARMY  
ROCK ISLAND DISTRICT CORPS OF ENGINEERS  
CLOCK TOWER BUILDING - P O BOX 2004  
ROCK ISLAND, ILLINOIS 61204 2004

May 13, 1987

Planning Division (1180)

Dr. David W. Benn  
Center for Archaeological  
Research  
Southwest Missouri  
State University  
Springfield, Missouri 65804-0089

Dear Dr. Benn:

We have completed our review of your draft report entitled Archaeology in the Mississippi River Floodplain at Sand Run Slough, Iowa, prepared for us under contract DACW25-86-C-0025. Overall, the report is acceptable and meets the requirements set forth in the Scope of Work.

Please make the changes or corrections indicated by reviewers prior to printing the final version. These changes, mostly of an editorial or format nature, should improve the report's readability and accuracy.

You are hereby directed to begin work on the final report. If you have any questions, please call Mr. Charles Smith at 309/788-6361, or write to the following address:

District Engineer  
U.S. Army Engineer District, Rock Island  
ATTN: Planning Division  
Clock Tower Building - P.O. Box 2004  
Rock Island, Illinois 61204-2004

Sincerely,

J. Paul VanHoorebeke  
Contracting Officer's  
Representative

Enclosures

# Project Review Comments

Type:   
 Concept:   
 Final:   
 Other: draft

Page 1 of     

Date:     

Project: CAR-690

Location: Archaeology in the Miss.  
River Flood Plain at  
Sand Run Slough

Reviewer:

Name: C. Smith

Organization: USAED Rock Island

Comment Number	Drawing/Page/		Comment	Action
	Number	Space		
1	1		Delete "National" before "Advisory Council ..." in the second paragraph and capitalize "Section 106."	
2	2		Delete the word "potentially" before "eligible for inclusion" in the second paragraph. Add a sentence describing the fact that Kay Simpson, SHPO Archeologist, agreed that the sites were eligible for listing on the National Register and that the Scope of Work for data recovery was reviewed and accepted by her and the ACHP's staff archeologist prior to advertisements.	
3	GEN		I think that your discussion of compliance issues and procedures could be improved by incorporating references and terms from the recently revised 36 CFR Part 800 regulation. For example, the following references should be used in the report: 800.2(c) area of potential effects 800.4(b) requirement to evaluate historic properties 800.4(c) application of National Register criteria 800.5(d)(1) no adverse effect procedures	
4	5		"Culturally" is misspelled.	
5	21		"Survey" is misspelled.	
6	35		What is the depth of the excavation planview.	

# Project Review Comments

Type: \_\_\_\_\_  
 Concept:   
 Final:   
 Other: \_\_\_\_\_

Page 2 of 4

Date: \_\_\_\_\_

Project: \_\_\_\_\_

Location: \_\_\_\_\_

Reviewer: \_\_\_\_\_

Name: \_\_\_\_\_

Organization: \_\_\_\_\_

Comment Number	Drawing/Page/		Comment	Action
	Number	Space		
7	GEN		There is a need to improve the separation of Sections, subsections, 3rd and 4th level subsections. It is not always clear what level of division applies and what subsections fit together.	
8	98		The second paragraph is inappropriate. It does not say much for your decision making process to state that time/money constraints were the most significant factors, particularly when you were in a proposal-driven procurement situation. If more resources were needed, they should have been proposed up front, or at the very least, early on in the analysis phase by a request for time or money. The last two lines of this paragraph are also very negative.	
9	100		There is a word missing in the third paragraph (the ?).	
10	101		There is a stratum number missing in the second paragraph (III ?).	
11	GEN		The use of classification data in tables 4 through 26 is a plus for future researchers and readers. While the quantity of information is overwhelming, it is easy to make comparisons between excavation blocks, strata, features, and debitage types. David Stanley is to be commended for a thorough and insightful analysis.	

# Project Review Comments

Type:   
 Concept:   
 Final:   
 Other:

Page 3 of \_\_\_\_\_

Date: \_\_\_\_\_

Project: \_\_\_\_\_

Location: \_\_\_\_\_

Reviewer: \_\_\_\_\_

Name: \_\_\_\_\_

Organization: \_\_\_\_\_

Comment Number	Drawing/Page/		Comment	Action
	Number	Space		
12	181		The word "of" is missing after the word "preponderance" in paragraph three.	
13	195		Write out the word "liter" in the second paragraph.	
14	224		How do you interpret the 6 elk bones found at 13LA30 as described in the USACE reconnaissance report (p. D-3)?	
15	233		The general discussion of the relationship between soils, landform evolution, presentation potentials, and cultural periods is intriguing and should be critical avenues for 1987 projects in Mississippi River Pools 17, 18, and 21.	
16	243		"Did" is misspelled in the last line.	
17	252		Chapter VIII is the reason this project was undertaken. All of the data that was classified, described, and tabulated in earlier chapters begin to assume meaning through the discussion of environment (object/instrument), technology, climate, social organization/change, and ideological-technological relationships. Whether the reader agrees with your interpretations or not is irrelevant, as you have provided clear lines of inquiry for the future. My only recommendation is that the discussion of Oneota (e.g. Christenson Site 13PK407) be expanded. The ending seems	





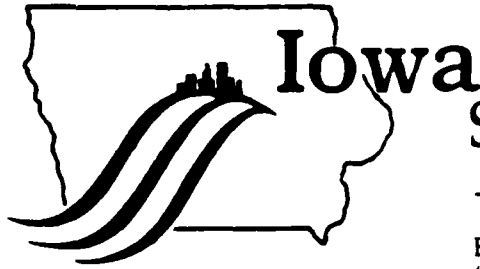

# Iowa State Historical Department

---

East 12th and Grand Avenue, Des Moines, Iowa 50319  
(515) 281-5111

May 5, 1987

Dudley M. Hanson P.E.  
Chief, Planning Division  
Rock Island District Corps of Engineers  
Clock Tower Building  
P.O. Box 2004  
Rock Island, IL 61204-2004

RE: DRAFT REPORT: ARCHAEOLOGY IN THE MISSISSIPPI RIVER  
FLOODPLAIN AT SAND RUN SLOUGH, IOWA. (DACW25-86-C-0025).

Dear Mr. Hanson:

I have reviewed the draft report for this project and make the following comments and recommendations. In general, the report meets the scope-of-work. All alterations to original contract appear to be the result of inclement weather and uncooperative water tables. The report is likely to be a significant contribution to the archeology of Woodland period sites in southeastern Iowa and to models of landscape archeology. Minor comments on report chapters follow.

Page 2. The last two sentences of the second paragraph should be amended to make it clear that 13LA38 and 30 were determined eligible by the Keeper, not listed on the National Register. Suggested wording: The COE and SHPO concurred that the Sand Run sites (13LA30 and 13LA38) met the criteria of eligibility for the National Register of Historic Places (NRHP). The Keeper of the NRHP determined the sites eligible on 15 November 1985.

Page 25-26. I felt the feature descriptions were too brief. What is contained in these two pages is a good summary, but I would like to see individual feature descriptions, perhaps in an appendix.

Page 27. I found Tables 2.2-2.4 difficult to read and correlate with the text and with Tables 3.1 and 3.2. All abbreviations should be keyed and consistent chapter to chapter (cf Table 3.2). Another table parallel to Table 3.2 should be included showing diagnostic sherds in relation to excavation levels and surface collections.

RICOE - SAND RUN SLOUGH  
PAGE 2

Page 71. The conclusion to such a useful chapter on southeastern Iowa ceramic assemblages is all too short. The third "difficulty" mentioned, that review and compliance archeology results in significant sites not being excavated, is perhaps negated by the very study at hand. How many of the truly significant sites excavated in Iowa have been excavated by research-oriented funding (and how many of these resulted in final reports?) and how many were excavated by Federal funding? At quick tabulation of projects listed in the author's own Previous Investigations section quickly leads to the conclusion that most of what we know about Louisa County was generated via R&C work.

Page 147. I have no basic complaint with the obviously well analyzed lithic section, but this chapter reads more like an appendix than a report chapter. The summary statements embedded within the text need to be highlighted and discussed in an introductory section and then reiterated in a concluding section. Sorely missed is a section on comparative chronology and stratigraphic seriation comparable to the ceramics discussion. Some of this is embedded in point and stratum discussions, but it is not well developed.

Page 255. I concur with the author that additional investigations still need to be persued at 13LA30. If additional funding is available, I urge the COE to develop a second testing program at 13LA30.

Page 256-57. The author has brought up a series of specialized studies that need to be completed at sites such as 13LA38. Most of these are not grant-eligible activities for SHPO funding, nor are they properly treated under an Agency's 106 responsibilities. However, there are general suggestions here which can be used to condition contracts to yield significant areal research when a site is under 106 review. These suggestions will also be useful if the COE develops a Preservation Treatment Plan for COE-managed properties in the Upper Mississippi.

I look forward to reading the final report.

Sincerely,



Kay Simpson  
Compliance and Archeological Survey



# Illinois Historic Preservation Agency

Old State Capitol • Springfield • 62701

217/785-4512

May 12, 1987

Mr. Dudley M. Hanson, P.E.  
Chief, Planning Division  
District Engineer  
U.S. Army Engineer District, Rock Island  
Attention: Planning Division  
Clock Tower Building - Post Office Box 2004  
Rock Island, Illinois 61204-2004

CF: \_\_\_\_\_

PD mea

PD-C \_\_\_\_\_

PD-E

PD-F \_\_\_\_\_

PD-P \_\_\_\_\_

PD-R \_\_\_\_\_

Dear Mr. Hanson:

It is with great pleasure that our staff reviewed the draft report entitled "Archaeology in the Mississippi River Floodplain at Sand Run Slough, Iowa" prepared by Dr. David Benn and Associates. Due to internal time restraints we have reviewed the draft for content only, however, it appears to be an extremely "clean" draft from a technical perspective.

This report is of the highest professional standards with regard to clarity of presentation, analysis and interpretive stance. The contribution of this work to our understanding of the culture history, especially the ceramic, lithic, and subsistence aspects, of this region will be significant. It will take on added importance once the analysis of the Putney Landing Middle and Late Woodland components from Illinois become available.

The only aspect of this research that is somewhat disturbing is the apparent lack of intra-stratum analysis and comparison. This makes it very difficult to fully comprehend the nature of component assemblages as cultural entities. This is not a major problem and to some extent stems from both the researchers explicit focus on cultural history and the decision to use as analytical units the categories of material culture. Organization and analysis by "specialties" rather than cultural components often provides very detailed diachronic views but seldom well-integrated assemblage perspectives.

The Corps of Engineers and Dr. Benn and his associates are both to be congratulated on an extremely successful archaeological research/compliance project. It is to be hoped that this report will be made available to a wide audience in the Upper Mississippi River Valley region.

Sincerely,

Thomas E. Emerson  
Chief Archaeologist

TEE:bv

APPENDIX B  
Soil Descriptions  
by  
E. A. Bettis III  
(Iowa Geological Survey Bureau)

58SR1

Location: 13LA38 unit B south wall 160cm east of west wall  
Landscape position: center of small alluvial/colluvial fan  
Slope: 9-14%  
Vegetation: hardwood forest  
Date described: 8/20/86  
Described by: E.A. Bettis III  
Remarks: described from hand probe below 180cm

<u>Depth (cm)</u>	<u>Soil Horizon</u>	<u>Description</u>
0-11	A	very dark grayish brown to dark grayish brown (10YR3/2-4/2) loam with occasional fine pebbles, weak to moderate fine granular, friable, noneffervescent, clear smooth boundary, abundant roots, occasional charcoal flecks
11-20	EB1	dark grayish brown (10YR4/2) silt loam with occasional fine and medium pebbles, weak fine subangular blocky, friable, noneffervescent, clear smooth boundary, abundant roots, very few thin discontinuous very dark grayish brown (10YR3/2) coatings on ped surfaces
20-27	EB2	dark grayish brown to brown (10YR4/2-4/3) silt loam, moderate fine to medium subangular blocky, friable, noneffervescent, clear smooth boundary, very few fine oxides, abundant roots, few thin discontinuous dark grayish brown (10YR4/2) coatings on peds, very few thin discontinuous grayish brown (10YR5/2) silt coatings
27-48	Bt1	brown to yellowish brown (10YR4/3-5/3) silt loam, moderate medium subangular blocky breaking to moderate fine angular blocky, friable, noneffervescent, abrupt wavy boundary, few fine oxides, common roots, common thin discontinuous very dark grayish brown to dark grayish brown

		(10YR3/2-4/2) cutans, few thin discontinuous grayish brown (10YR5/2) silt coatings on cutans
48-64	Bt2	dark brown to dark grayish brown (10YR3/3-4/2) silt loam, moderate medium subangular blocky, firm, noneffervescent, abrupt smooth boundary, common fine oxides, common roots, common thin almost continuous very dark grayish brown (10YR3/2) cutans, abundant charcoal and burned earth (midden)
64-70	2Atb	very dark grayish brown (10YR3/2) silt loam, moderate coarse subangular blocky breaking to moderate medium angular blocky, firm to friable, noneffervescent, gradual smooth boundary, oxides as above, few fine iron concretions, occasional roots, common thin continuous very dark gray (10YR3/1) cutans, abundant charcoal and burned earth (midden)
70-85	2ABtb	dark grayish brown to brown (10YR4/2-4/3) silt loam with abundant fine pebbles, moderate medium subangular blocky, friable, noneffervescent, clear smooth boundary, oxides and iron concretions as above, occasional roots, common thin continuous very dark gray to very dark grayish brown (10YR3/1-3/2) cutans, abundant charcoal and burned earth (midden)
85-102	2Bt1b	yellowish brown (10YR5/4) silt loam with common fine to medium pebbles, moderate medium columnar, firm, noneffervescent, gradual boundary, abundant fine oxides, very few fine iron concretions, common roots, common thin continuous dark grayish brown (10YR4/2) cutans
102-120	2Bt2b	brown(10YR4/3) silt loam with

		<p>common medium to fine pebbles, strong coarse columnar breaking to moderate medium angular blocky, firm, noneffervescent, abrupt smooth boundary, common fine oxides, common roots, common thin continuous very dark grayish brown to dark brown (10YR3/2-3/3) cutans, abundant charcoal and artifacts (midden)</p>
120-130	3ABtb	<p>dark brown to brown (10YR3/3-4/3) silt loam with common fine pebbles, moderate to strong medium angular blocky, firm, noneffervescent, clear wavy boundary, common roots, common thin almost continuous very dark grayish brown (10YR3/2) cutans, abundant charcoal and burned earth (midden)</p>
130-143	3Btb	<p>dark grayish brown to dark yellowish brown (10YR4/2-4/4) silt loam, moderate coarse columnar breaking to strong medium subangular blocky, firm, noneffervescent, abrupt smooth boundary, common fine oxides, few fine iron concretions, few roots, common thin continuous very dark grayish brown (10YR3/2) cutans</p>
143-166	4AeBtb	<p>dark brown to dark grayish brown (10YR3/3-4/2) loam, moderate coarse columnar, friable, noneffervescent, clear irregular boundary, common thin almost continuous very dark grayish brown (10YR3/2) cutans, this horizon is very disturbed by midden forming activity</p>
166-180	4Bt1b	<p>brown to dark yellowish brown (10YR4/3-4/4) loam, weak medium to fine subangular blocky, friable, noneffervescent, gradual smooth boundary, very few fine oxides, few thin discontinuous very dark grayish brown (10YR3/2) cutans, common charcoal and few fire cracked rocks</p>



180-205	4Bt2b	brown (10YR4/3) heavy loam with common medium pebbles, moderate medium columnar, friable, noneffervescent, gradual boundary, oxides as above, cutans as above
205-240	4BCb	brown (10YR4/3) loam, weak medium subangular blocky, friable, noneffervescent, abrupt boundary, common medium dark gray (10YR4/1) mottles along root channels, few thin discontinuous dark grayish brown (10YR4/2) cutans
240-257	5ACb	dark grayish brown to brown (10YR4/2-4/3) loam with common coarse sand grains, very weak medium to fine subangular blocky, friable, noneffervescent, gradual boundary, very few thin discontinuous very dark grayish brown to dark grayish brown (10YR3/2-4/2) cutans, abundant charcoal
257-base (297)	5C	dark yellowish brown to yellowish brown (10YR4/4-5/4) loam with occasional fine pebbles, massive, friable, noneffervescent, common medium to coarse grayish brown (2.5Y5/2) mottles along root channels, few fine iron concretions

58SR2

Location: 13LA38 unit C 17S7E west wall  
Landscape position: downstream side of small alluvial/colluvial fan  
Slope: 5-9%  
Vegetation: mixed hardwood forest  
Date described: 8/20/86  
Described by: E.A. Bettis III  
Remarks: described from hand probe below 154cm

<u>Depth (cm)</u>	<u>Soil Horizon</u>	<u>Description</u>
0-10	A	very dark grayish brown to dark brown (10YR3/2-3/3) loam, moderate medium granular, friable, noneffervescent, clear smooth boundary, abundant roots
10-22	AB	dark brown to brown (10YR3/3-4/3) loam, moderate fine subangular blocky, friable, noneffervescent, abrupt smooth boundary, abundant roots, few thin discontinuous very dark grayish brown (10YR3/2) coatings on ped surfaces
22-30	2Ab	dark grayish brown (10YR4/2) silt loam, weak to moderate medium to fine subangular blocky, friable, noneffervescent, clear smooth boundary, abundant roots, coatings on peds as above
30-42	2Bwb	brown (10YR4/3) loam with few fine pebbles, weak to moderate medium subangular blocky, friable, noneffervescent, abrupt smooth boundary, abundant roots, very few thin discontinuous grayish brown (10YR5/2) silt coatings on peds
42-51	3Ab	very dark grayish brown (10YR3/2) loam with common coarse sand grains, moderate medium to fine subangular blocky, friable, noneffervescent, gradual smooth boundary, common roots, few thin discontinuous grayish brown (10YR5/2) silt coatings on peds

51-69	3ABb	very dark grayish brown to dark brown (10YR3/2-3/3) heavy loam, moderate medium subangular blocky breaking to moderate fine subangular blocky, friable, noneffervescent, gradual smooth boundary, few roots, abundant charcoal and burned earth (midden)
69-83	3ABtb	very dark grayish brown to dark gray (10YR3/2-4/1) clay loam, moderate medium subangular blocky, friable, noneffervescent, abrupt smooth boundary, few roots, few thin discontinuous very dark gray (10YR3/1) cutans, abundant midden materials
83-98	4Atb	very dark gray to very dark grayish brown (10YR3/1-3/2) heavy loam, moderate medium subangular blocky, friable, noneffervescent, gradual smooth boundary, common roots, few thin discontinuous dark gray (10YR4/1) cutans
98-115	4AeBtb	very dark grayish brown (10YR3/2) loam, moderate medium columnar, friable, noneffervescent, clear smooth boundary, few roots, common thin discontinuous very dark gray (10YR3/1) cutans, common midden materials
115-125	4BtAeb	very dark grayish brown (10YR3/2) clay loam, moderate medium to fine subangular blocky, friable, noneffervescent, clear smooth boundary, very few roots, cutans as above, abundant midden materials
125-135	4Bt1b	very dark grayish brown to brown (10YR3/2-4/3) loam, weak to moderate medium subangular blocky, friable, noneffervescent, gradual smooth boundary, few roots, few thin discontinuous very dark grayish brown to very dark gray (10YR3/2-3/1) cutans
135-154	4Bt2b	dark yellowish brown (10YR4/4) loam, weak to moderate medium subangular blocky, friable, non-

		effervescent, gradual boundary, very few roots, few thin discontinuous dark grayish brown to brown (10YR4/2-4/3) cutans, occasional charcoal flecks
154-173	4BCb	brown (10YR4/3) loam, weak coarse columnar, friable, noneffervescent, clear boundary very few fine grayish brown (2.5Y5/2) mottles along root channels
173-base (223)	4CBb	brown to dark yellowish brown (10YR4/3-4/4) loam, massive, friable, noneffervescent, common medium dark gray (5Y4/1) mottles along root channels, abundant charcoal from 215 to 220cm

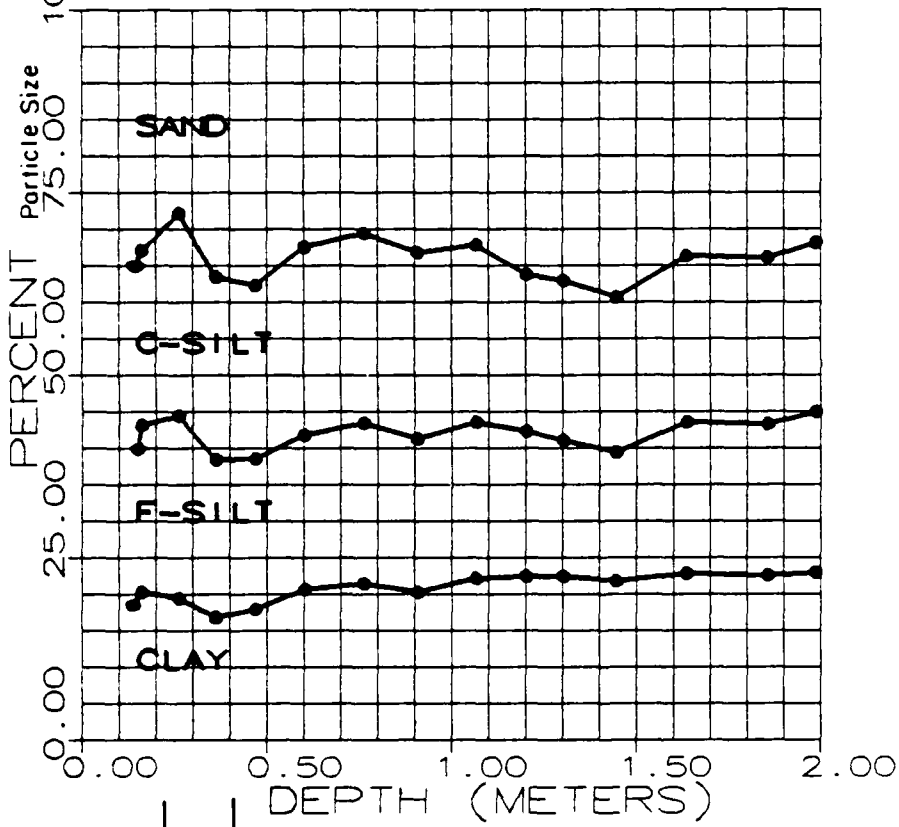
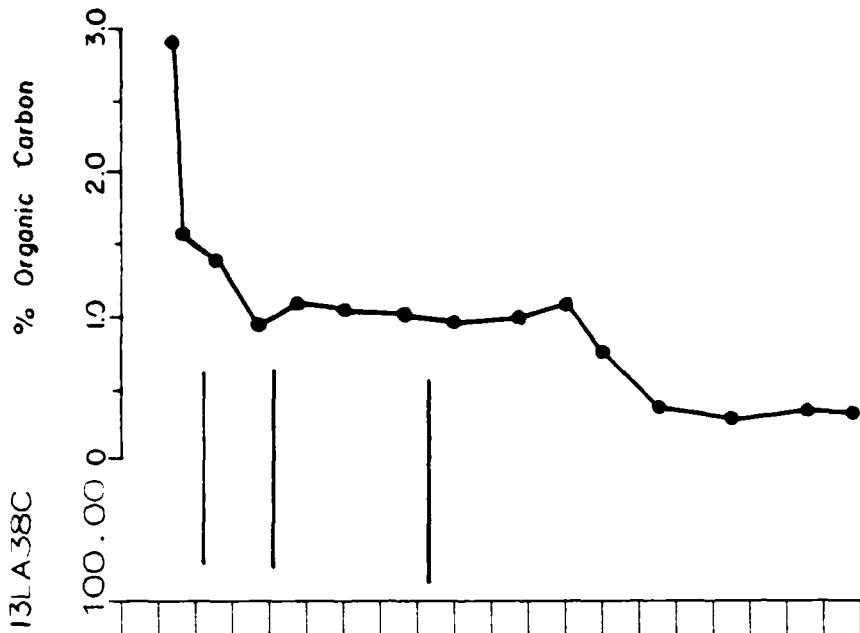

Depositional Unit

Ia

Ib

II

III

PROFILE 58SR2

APPENDIX C  
Ceramic Definitions  
Wares

## Ceramic Definitions

br = brushed  
 bur = burnished (light reflects from pottery surface)  
 ci = cord impressed  
 cr = cord roughened (also "cordmarked")  
 cws = cord-wrapped stick  
 den = dentate  
 dia = diameter  
 dp = depth (as in depth of a channel or impression)  
 embossing = ("node"; a dome of paste caused by an interior punctation)  
 imp = impressed  
 lg = length  
 lip form: round = no corners or sharp imflections  
           round-flat = corners are rounded, lip is slightly flat  
           flat = corners are sharp, lip is flat  
           bevelled = lip is oriented (usually 30-45 degrees) from horizontal  
           extruded = paste is pressed outward beyond vessel wall  
 pl = plain (surface is completely smoothed)  
 punctate = a round impression on the exterior surface  
 rim form: str = straight (virtually no perceptible curve)  
           sl cur = slightly curved (gentle bend usually less than 20 degrees)  
           cur = curved (even bend more than 20 degrees)  
 socr = smoothed-over-cord roughened  
 stab = slash  
 walls: thick >7.4mm, thin <7.4mm  
 wd = width

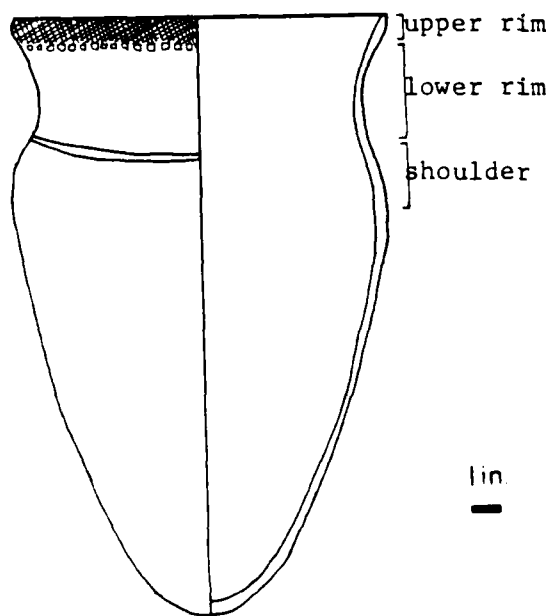

reconstructed Baehr/Pike vessel  
from fea. 5a Block C (see Fig. 3.11d)

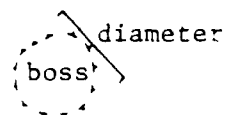

embossing measurements:  
 taken from center of boss  
 to lip, and from center to  
 center of bosses

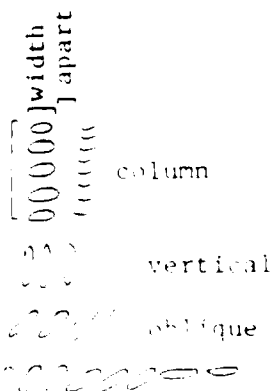

MARION WARE  
13LA30/38

Paste: coarse silts and clays with moderate amounts of fine-medium sand inclusions; tempered with moderate amounts of very coarse (1-8mm) crushed igneous rock; coarse textured, massive to slightly blocky structure; relatively hard (3-4 Mohs scale) and heavy walled.

Color: yellowish red (SYR5/8) to dark gray (10YR4/1) mottle on most surfaces; cores same colors or slightly reduced (darker).

Surface Treatment: sometimes vague and superimposed impressions of coarse cord roughening or coarse fabric on exterior and interior surfaces.

Form: (one vessel) straight, vertical rim with somewhat flattened lip; no shoulder; body walls average 12.8mm thick.

Decoration: none.

Synonymy: Griffin 1952.

LIVERPOOL WARE  
13LA30/38

Paste: coarse silts and clays with large amounts of fine-medium sand inclusions; medium-coarse sand (.5-5mm range) probably added as temper; very few sherds with crushed rock temper; coarse textured, massive structure; relatively hard (3-4 Mohs scale) and heavy walled.

Color: exterior and interior surfaces usually dark grayish brown (10YR4/2); some surfaces range from yellowish red (SYR5/8) to very dark gray (10YR3/1); cores same colors as surfaces or slightly more reduced (i.e. darker grays).

Surface Treatment: interiors broadly smoothed while damp, but retain many finger and molding impressions; lips occasionally retain cord roughening impressions; exteriors covered by deep impressions of loosely-twisted cords (always S twist); cord impressions are closely spaced and displace paste to surface ridges; cord directions are vertical or oblique (down to the left) and tend to bend left on the lower body.

Method of Manufacture: probably building and thinning by paddle and anvil.



Form: relatively small, squat conoidal vessels with vertical to insloping rim and little or no shoulder; lips round or slightly flattened and everted in half of the sample; rims mostly straight; lip thickness (ave. 6.1mm) is thinner than rim walls (ave. 9.0mm) or body walls (ave. 8.3mm); orifice diameters average about 177mm.

Decoration: a small proportion of rims lack exterior decoration; almost all rims have a row of embossing set close to the lip; 40% of the sample with tool or cord-wrapped-stick impressions on the interior upper rim; lips rarely decorated; exterior rim and body usually covered by zones of parallel lines trailed in soft paste so that paste is displaced in ridges; sometimes rows of stabs or fingernail impressions accompany the lines; lines almost always are rectilinear.

Synonymy: Black Sand Incised (Griffin 1952); Prairie ware (cf. Spring Hollow Incised) (Stoltman 1986; Logan 1976); Fox Lake ware (Hudak 1976; Anfinson ed. 1979); McBride ware (Benn and Rogers 1985); Crawford ware (Benn 1983).

Types: Liverpool Cordmarked is undecorated; Black Sand Incised is heavily decorated on the exterior surface.

MORTON WARE  
13LA30/38

Paste coarse silts and clays, often quite sandy like Liverpool ware; tempered with coarse sand (.5-3mm) in many Sister Creeks sherds, and tempered with small to moderated amounts of sand and crushed igneous rock (.25-2mm) in Morton Incised; coarse texture, massive structure except in some block structured Morton Incised rims; moderately hard (3-4 Mohs scale) and heavy walled.

Color: exteriors light brownish gray (10YR6/1) to dark gray (10YR4/1) to yellowish red (5YR5/6); interiors slightly darker; core colors are a blend of exterior colors; firing clouds evident on exteriors.

Surface Treatment: interiors plain; two-thirds of lips plain, and the others retain some cord roughing; one-quarter plain and three-quarters of exteriors covered by vertical, low-relief cord roughening when not covered by decoration.

Method of Manufacture: building.

Form: large, conoidal vessels with slightly constricted necks; lips are tool finished round or flat; rims may be straight or slightly curved, and are insloping or vertically oriented; shoulders are steep; lip thickness (ave. 7.6) is slightly less

than rim walls (ave. 8.3mm) in the Sister Creeks type; orifice diameters are large, averaging 234mm.

Decoration: none in Sister Creeks type; Morton/Fattie Incised has a row of cord-wrapped-stick stamps on both rim interiors; lips usually are not decorated; a row of embossing occurs on the upper rim; exterior rim and body decorations consist of rows and columns of fingernail or stab impressions in the Sister Creeks type, and of elaborate zones of nested trailed lines in the Morton Incised type.

Types: Sister Creeks Punctated, Morton Incised.

Synonymy: Griffin 1952; some Spring Hollow Incised (Logan 1976) rims similar to Morton Incised.

HAVANA WARE  
13LA30/38

Paste: coarse silts and clays; tempered with moderate to heavy amounts of crushed igneous rock (.5-4mm); coarse textured, blocky structure; somewhat soft to moderately hard (2-4 Mohs scale) and heavy walled; sherds sometimes friable or crumbly.

Color: most sherds brown (10YR5/3) with a range of light yellowish brown (10YR6/4) to black (10YR2.5/1); cores same as surfaces except for black smudges and pale firing clouds, which are common; some carbon incrustations.

Surface Treatment: interiors plain; exteriors 90% plain or smoothed-over-cord roughened; plain surfaces appear to be smoothed by wet tool, giving the appearance that a slip was applied; cord roughening is composed of low-relief, tightly-twisted cords applied vertically on the exterior.

Method of Manufacture: building.

Form: large, conoidal vessels with slightly constricted necks, slightly flaring rims and sharply rounded bases; almost all lips tooled flat and often bevelled inward (ca. 75%); rims straight or slightly curved, and vertical or slightly flaring; lip (Naples ave. 9.5mm) and rim (ave. 8.9mm) thicknesses tend to be close because of excessive lip flattening; orifice diameters average about 200mm.

Decoration: very few rims are undecorated; interior upper rim decorations are rare, and lip decoration is not present; almost all upper rims have a row of embossing; otherwise, many forms of decoration comprise the several types of Havana ware; decorations occur in zones piled from the upper rim to the mid-body of the

vessel; horizontal trailed lines often separate the decorative zones; bold dentate stamps dominate in the decorative assemblage.

Types: Naples Dentate Stamped, Havana Cordwrapped Stick Stamped, Havana Cordmarked, Havana Plain, Havana Zoned Dentate, Hummel Stamped, Neteler Stamped, Havana Incised.

Synonymy: Griffin 1952; High Bridge ware (Benn and Rogers 1985); Fox Lake ware (Anfinson ed. 1979); Valley ware (Kivett 1949; Benn 1983).

WEAVER WARE  
13LA30/38

Paste: coarse silts and clays; tempered with moderate to large amounts of finely crushed igneous rock (.25-2mm) and occasional pieces of coarse (2-5mm) crushed igneous rock; medium to coarse pastes with fine blocky structure; sherds moderately hard (3 Mohs scale) and dense.

Color: interiors and exteriors very pale brown (10YR7/4) to very dark gray (10YR3/1) with darker values predominant; cores same colors; firing clouds and smudging common; few carbon incrustations.

Surface Treatment: almost all rims smoothed and plain, with at least 10% being burnished; a few have exterior cord roughening (vertical); body sherds have a higher proportion of cord roughening or smoothed-over-cord roughening; cords are thin, tightly twisted and widely spaced.

Method of Manufacture: probably building.

Form: sub-conoidal vessels with constricted necks and flaring rims; lips round and slightly thinned; rims curved and vertical to flaring; shoulders gently expanding; lip thickness (ave. 4.6mm) thinner than rim walls (ave. 5.5mm); orifice diameter averages about 200mm.

Decoration: a row of embossing occurs on the cord roughened rims; 70% of the plain rims a row of vertical or oblique impressions on the exterior upper rim.

Synonymy: Griffin 1952; Spring Hollow Plain (Logan 1976); Madrid Cord Roughened and Plain (Benn and Rogers 1985); Arthur Cord Roughened (Benn 1982); Held Creek ware (Benn ed. 1981).

Types: Weaver Cordmarked, Weaver Plain.

CORD DECORATED WARE(S)  
13LA30/38

Paste: coarse silts and clays; tempered with moderate amounts of fine crushed rock and grit (.25-2mm) and variable amounts of coarse crushed rock (2-5mm); moderately coarse textured; fine blocky to laminated structure.

Color: most exterior and interiors brown (7.5YR4/2-5/2) with ranges from yellowish red (5YR4/6) to very dark gray (7.5YR3/0); interiors tend to be much darker (smudged); cores like surfaces or may be reduced or oxidized; firing clouds common.

Surface Treatment: interiors smoothed and even except for paste displaced by exterior decoration impressions; lips plain; 80% exteriors covered by low-relief cord roughening and decorations; remainder have plain rims.

Method of Manufacture: building and thinning by paddling.

Form: probably globular vessels with wide shoulders, constricted necks and flaring rims; thinned round lips; curved, vertical to flaring rims (there is no evidence of castellations, but they may be present with sherds of large size); expanded shoulders; lips thinner (ave. 4.7mm) than rim walls (ave. 5.6mm); orifice diameter averages 204mm.

Decoration: very few rims undecorated; about 70% interior upper rims undecorated, while remaining rims have cord or tool impressions; about two-thirds of lips impressed with cords (many "scalloped"); exterior rim decoration in three zones: upper and lower bands of short impressions bordering a central zone of cord roughening or evenly-spaced parallel cord impressions.

Synonymy: Riggle 1981; Morgan 1985b; Canton ware (Fowler 1955); Minotts Cord Impressed (Logan 1976); Madison ware (Hurley 1975; Benn 1978); Loseke ware (Kivett 1942; Benn and Rogers 1985).

Types: cord roughened, cord impressed (early, late).

APPENDIX D  
Lithic Attributes and Definitions

## LITHIC ATTRIBUTES AND DEFINITIONS

### Detachment Techniques

Hardhammer Percussion: refers to the use of a hammerstone as a percussor. Hammerstones may represent a variety of sizes and weights depending upon what's required of them. Flakes detached by hardhammer percussion are relatively thick and large with high platform angles, large protrusive bulbs of percussion, and a cone of percussion. The point of impact is near the ventral edge of the striking platform.

Softhammer Percussion: refers to the use of an antler, a piece of wood, or a bone as a percussor. This technique produces a thin flake with a low striking platform, a diffuse bulb of percussion, no cone of percussion, and a lip-like protrusion on the ventral edge of the platform. The point of impact is located on the dorsal edge of the platform.

Pressure Flaking: refers to the use of manual pressure by holding the incipient tool on a pad or cushion then apply pressure by pressing off the flake with a percussor, such as bone, wood, claw, tooth, or antler.

Bipolar Flaking: refers to the use of an anvil and is generally associated with working pebble tools and/or very small cores. Flakes usually exhibit bulbs of percussion at both ends (due to the rebounding of the secondary mechanical force produced by pressing the core to the anvil). Cores generally have heavily battered ends opposite the striking platforms.

### Technological Characteristics

#### 4. Striking Platform Types

Bifacial Tool Edge Platform: associated with re-sharpening or edge rejuvenation. A series of proximal ends of negative flake scars are visible on the platform which has a very low angle. If the tool being rejuvenated is bifacial then the dorsal surface of the flake also exhibits the proximal ends of the flake scars.

Unfaceted Platform: a flat, concave, or convex surface resulting from a previous flake scar that may or may not have been associated with preparing the platform.

Faceted Platform: intentional, more or less parallel, flake scars at a right angle to the width of the platform surface.

Edge-Faceted Platform: platform surface has not been prepared but the dorsal edge of the platform surface has had two or more contiguous flakes removed resulting in a serrated appearance. This type of edge faceting is not to be confused with the point of impact.

Double-Faceted Platform: the removal of two noncontiguous flakes along the dorsal edge of the platform resulting in a flat space in between which is used as the point of impact.

Single-Faceted Platform: convex, concave, or flat surface created by the removal of one small flake approximatel. the size of the visible platform.

Pseudo-Faceted Platform: this type of surface occurs when an area along the edge of a core or tool has fortuitous irregular flake scars, or damage associated with the detachment process.

Binedral Platform: a surface that has one prominent ridge which is the result of two adjoining flake scars.

Striding: may be a feature of any of the previously described platform types. It is distinguished by abrasion on either the edge or surface of the striking platform.

#### Flake Production

##### 4. Cores.

Unmodified and Nonlocal Cobbles: stones and cobbles without observable modifications; must be distinguished from natural rock in the soil at the site.

Test Cobbles: cobbles with one striking platform and a few flakes removed; must not show evidence of use-wear along the flaked edge (i.e. as a chopper).

Working Cores: more than 50mm in size; stone with one or more striking platforms, cortex removal, and evidence of primary flake production from at least 1 shaped flaking face. There are several types of working cores:

single-platform cores: flaked in a single direction along a portion or the entire circumference of the platform, either prismatic or in a tabular shape.

double-platform cores: there are two platforms at opposite ends of the core and flakes can be attached from either platform. They generally have biconical cross-sections and are often associated with core-tool production.

polymorphic cores: these cores have three or more striking platforms that are independent of each other.

disoidal cores: flat cores from which flakes of approximately equal size were detached around the entire circumference so that flake scars overlap or meet at the center.

bipolar cores: this category contains both single- and double-ended varieties. Bipolar cores display evidence of the use of an anvil while being struck by a percussor.

Exhausted cores: less than 50cm in size; stone with most or all of the core removed; 1 or more striking platforms, and evidence of primary flake production from 2 or more flake faces; typically, too small to handle effectively while knapping.

Core Fragments: broken fragments with one or more platforms or some other evidence of flake production.

b. Flakes and flake fragments removed from cores.

These flakes are usually detached by handhammer percussion and often serve as flake blanks, however, they may also represent thinning flakes if a raw nodule is being worked directly into a tool and could be detached by softhammer percussion or pressure flaking (e.g. small tabular nodules, such as Warsaw Tabular chert). All flakes must have some of the characteristics associated with flakes such as platforms, bulbs of percussion, ripple marks, etc.

Primary Deposition: flakes with the dorsal surface entirely covered by cortex or pre-cultural patina.

Secondary Deposition Flake: flakes with the dorsal surface partially covered by cortex or pre-cultural patina and negative flake scars.

Interior: flakes with dorsal surfaces that lack any evidence of cortex or pre-cultural patina and are covered entirely by negative flake scars.

Edge Renovation: flakes detached from a core for the purpose of reconstructing or altering a striking platform. Dorsal surfaces generally exhibit portions of a striking platform.

blades: flakes with 3:1 length-width ratio, parallel longitudinal flake scars on dorsal surface, and preparation of the striking platform blade production represents a distinctive stone tool industry and is analyzed separately, using subcategories.



#### Primary Thinning Flakes.

These flakes are the by-products of chipped stone tool manufacture and are associated not only with the sequential stages of manufacture but also with the production and function of certain tool types. Thinning flakes in general have relatively low platform angles.

Primary Thinning Flakes: It is at this stage of biface manufacture that a ventricular cross-section is obtained and major humps, ridges, and large in-step fractures are eliminated. Uniface manufacture produces similar flake types. The dorsal surfaces generally contain the features described above as well as negative flake scars, the platform angle is relatively low, and they were detached usually by softhammer percussion although hardhammer percussion may also occur.

Secondary Thinning Flakes: It is at this stage of biface manufacture that a flattened cross-section is obtained resulting in flake scars that often transverse the entire tool surface and undercut previous flake scars. The dorsal surfaces of these flake types generally have two or more shallow flake scars and have a one or more ridges. The platform angle is very low and there is usually evidence of platform preparation on a portion of the biface or uniface edge. These flake types, produced almost exclusively by softhammer percussion, are very thin.

Tertiary Thinning Flakes: These flakes are smaller than 1cm, have little or no evidence of a platform, and are wafer thin. They are detached exclusively by pressure flaking and are a result of edge thinning or spalling.

#### Other Flake Types.

Retouch Flakes: These flakes are the result of re-sharpening or re-orienting a tool edge. They are generally expanding side flakes which retain a portion of the uniface or biface edge, which is quite often re-used.

Ingots: Irregular angular or tabular shaped chunks of stone with uneven faces and leading edges and platforms, or less or no platform, middle barbs, etc.

Flake Fragments: Flake fragments that are unidentifiable, i.e., not distinguishable as to specific detachment.

ipped into the file

#### 4. Unifacial Flaked Tools

1. Primary Flaked Uniface: shaping consists of primary flaking on one face only.

2. Secondary Flaked Uniface: shaping consists of secondary flaking on one face only.

#### 5. Bifacial Flaking

Biface: a round, oval, triangular, or rectangular form with a regular cross-section that has been shaped by primary flaking on both faces; bifaces measured according to their thickness width proportion.

1. Primary Flaked Biface: shaping consists only of primary flaking.

2. Secondary Flaked Biface: faces and edges shaped by primary and secondary flaking.

3. Initial Edged Biface: only the edges of the tool have been bifacially flaked, not the entire face.

Edged Biface: surfaces and edges shaped by primary and secondary flaking; artifact is transversal, asymmetrical, one end with evidence of flaking.

1. Longitudinally Edged: artifact is longitudinally asymmetrical such that the working surface is the lateral edges.

2. Transversally Edged: distal end is shaped as the working edge.

3. Narrow Bifaced: distal end is narrowed by steep secondary flaking to give a crescent-shaped cross-section; working end is thick and blunt.

4. Pointed: longitudinally asymmetrical biface with primary and secondary flaking; distal element proximal adapted for banding tools by the sharp distal end is pointed.

APPENDIX E  
Archaeobotany  
Raw Data

# Stratum II

Fuel, Unsubstantiated Remains, Wood Charcoal, Bark, Living Fragments, Fungal Rescues, Insect/Herb stems, etc.	Area A			Area B			Area C			Station II Totals	
	Feb. 8	Feb. 9	Feb. 10	Feb. 3	Feb. 6	Feb. 7	Feb. 9	Feb. 31	Feb. 5b		
	wt.	wt.	wt.	wt.	wt.	wt.	wt.	wt.	wt.	wt.	
Arctostaphylos Remains	2	07	2	2	03	4	03	8	02	13	04
Poa spp.	7	03	7	7	05	3	02	2	03	13	02
Taraxacum spp.	7	03	7	3	02	4	01	3	02	2	01
Chenopodium spp.	7	03	7	3	02	4	01	3	02	2	01
Polypodium	1	02	1	1	02	1	02	1	02	1	02
Unidentified	1	02	1	1	02	1	02	1	02	1	02
Squash Rind	2	01	2	2	01	2	01	2	01	2	01
Unidentified	2	01	2	2	01	2	01	2	01	2	01
Totals	185	173	123	122	145	140	102	112	124	123	113
Residual Weight (g)	372	310	317	368	517	308	628	608	614	614	614
Simple Volume (cc)	8	4	4	9	4	7	9	9	7	7	7
Density (g/100cc)	708	819	824	1013	824	543	828	828	828	828	828



Miscellaneous Features - Area C

Description	Shaloom I Feb. 1		Shaloom III Feb. 7		Shaloom II Feb. 7-1		Site Totals All Features wt	Wigwag No. Samples	Indices % Total
	ct	wt	ct	wt	ct	wt			
Arch/Construction Remains	1	0.6	1	0.6	1	0.6	1	100	
Oval Charcoal	1	0.4	1	0.4	1	0.4	1	100	
Bark	1	0.2	1	0.2	1	0.2	1	100	
Twig Fragments	1	0.2	1	0.2	1	0.2	1	100	
Partial Fishbones	1	0.2	1	0.2	1	0.2	1	100	
Wraps/Herb Stems	1	0.2	1	0.2	1	0.2	1	100	
S. Totals	5	1.6	5	1.6	5	1.6	5	100	
Nutshell Remains	1	0.6	1	0.6	1	0.6	1	100	
Unsp. spp.	1	0.6	1	0.6	1	0.6	1	100	
Junco spp.	1	0.6	1	0.6	1	0.6	1	100	
Turdus spp.	1	0.6	1	0.6	1	0.6	1	100	
Spizella spp.	1	0.6	1	0.6	1	0.6	1	100	
Ceryle americana	1	0.6	1	0.6	1	0.6	1	100	
S. Totals	5	3.0	5	3.0	5	3.0	5	100	
Unidentified Stems	1	0.6	1	0.6	1	0.6	1	100	
Unident. Stems/Rhizomes	1	0.6	1	0.6	1	0.6	1	100	
Balls	1	0.6	1	0.6	1	0.6	1	100	
Unsp. Kind	1	0.6	1	0.6	1	0.6	1	100	
Unidentified	1	0.6	1	0.6	1	0.6	1	100	
Totals	5	3.0	5	3.0	5	3.0	5	100	
Residual Weight (g)	104	136	104	136	104	136	104	136	
Sample Volume (L)	10.08	12.5	10.08	12.5	10.08	12.5	10.08	12.5	
Density (g/100L)	10.31	10.88	10.31	10.88	10.31	10.88	10.31	10.88	









Station II

Species	Area A		Area B		Area C		Station II Totals	% total identified
	Sta. 8 Feb. 8	Sta. 4 Feb. 4	Sta. 3 Feb. 3	Sta. 6 Feb. 6	Sta. 7 Feb. 7	Sta. 9 Feb. 9		
Aster cf. cubanus Aster spp.			1					1
Carya spp. (true type)		2						2
Carya spp. (persim type)								
Carya cf. laciniosa								
Carya spp. (undetermined)								
Callis/Alnus spp.			2					2
Elaeagnus spp.			2					2
Gleditsia/Gonocarpus spp.								
Gleditsia triacanthos								
Juglans spp.								
Morus rubra								
Populus/Salix spp.								
Salix spp.								
cf. Pinus spp.								
Quercus spp. (white)								
Quercus spp. (oak)								
Quercus spp. (undetermined)								
Tilia americana								
Knotwood								
Ring Porous								
Scrubby Porous								
Diffuse Porous								
Undetermined								
Totals	20	20	20	20	20	20	146	100.1

All from Area B.

Species	Station IIIa Feb. 18		Station IIIa Feb. 23		Station IIIb Feb. 25		Station IIIc Feb. 27		Station IIIc Feb. 28		Station IIIc Totals	% total identified
	ct	at	ct	at	ct	at	ct	at	ct	at		
<i>Quercus</i> sp.												
<i>Quercus</i> sp. (live type)												
<i>Quercus</i> sp. (prugnifolia type)												
<i>Quercus</i> sp. (oblongifolia type)												
<i>Quercus</i> sp. (indeterminate)												
<i>Celtis/Vinus</i> spp.	6											
<i>Fraxinus</i> spp.												
<i>Salix/Populus/Eximius</i> spp.												
<i>Salix/Populus/Eximius</i> spp.												
<i>Juglans</i> spp.												
<i>Alnus</i> spp.												
<i>Populus/Salix</i> spp.	6											
<i>Salix</i> spp.												
<i>A. Prunus</i> spp.												
<i>Quercus</i> sp. (white)												
<i>Quercus</i> sp. (red)												
<i>Quercus</i> sp. (indeterminate)	2											
<i>Lilium americanum</i>												
<i>Knottwood</i>												
<i>Ring Porous</i>												
<i>Lept-Ring Porous</i>												
<i>Diffuse Porous</i>												
<i>Indeterminate</i>												
Totals	20	20	20	20	20	20	20	20	20	20	140	99.9

Miscellaneous Features - Area C

Station I Fea. I ct	Station II Fea. 9 ct	Station III Fea. 17 ct	Stratum III Fea. 1-1 ct	Site Totals All Features ct	Ubiquity Indices No. / Samples	Total %
				6	1	17
	2			9	1	24
		4		35	13	68
	2			4	1	15
			2	4	1	20
				24	13	65
			2	25	12	60
				5	3	10
				3	3	10
				13	9	45
				4	3	15
				21	9	45
				2	1	10
				1	1	3
				25	16	80
				15	7	36
				11	4	20
				3	2	10
				31	19	80
				4	1	10
				18	7	36
				3	1	10
				14	7	36
				20	10	50
				400	2	10
				20	9	45
				4	1	10
				18	7	36
				3	1	10
				14	7	36
				20	10	50
				400	2	10

- Alex cf. cubanus
- Alex spp.
- Carya spp. (true)
- Carya spp. (pican)
- Carya cf. cordiformis
- Carya spp. (indeterminate)
- Callis/Alnus spp.
- Erxinus spp.
- Castanea/Quercus spp.
- Castanea tricanthos
- Liquidans spp.
- Neris cubae
- Populus/Salix spp.
- Salix spp.
- cf. Alnus spp.
- Quercus spp. (white)
- Quercus spp. (red)
- Quercus spp. (indeterminate)
- Zizia americana
- Kryptopod
- Ring Porous
- Sink-ring Porous
- Diffuse Porous
- Indeterminate
- Totals

APPENDIX F  
Human Remains

## HUMAN CRANIAL FRAGMENTS FROM SITE 13LA38

Alton K. Fisher\*

This site is located on Sand Run Slough near Lake Odessa. The specimen received from Dr. David W. Benn consisted of approximately 210 ml of cranial fragments with approximately 7 ml of very fine gravel intermixed.

Three of the largest bone fragments were about 30 mm in greatest diameter, 14 fragments were between 20 and 30 mm in greatest diameter and the remainder were much smaller. The smallest fragments were around 2 to 3 mm in size. Vascular depressions on the endocranial surface of two of the largest fragments were similar to those found on adult parietal bones. The larger fragments tended to be thicker than the smaller ones, as might have been expected, because the greater bulk of bone was more resistant to breakage. The thickness of the larger fragments varied between 5 and 8 mm. This is compatible with adult status. The two largest fragments included segments of cranial vault sutures. Suture closure appeared complete on the endocranial surface and almost complete ecto-cranially. These limited observations suggest that the individual was somewhat older than 30 years of age at the time of death but there were no indications of sex or race.

\*Examination completed on 8 June 1987

END

10-87

DTIC