

AD-A183 403

A VERSATILE INTERFACE FOR INSTRUMENT CONTROL (U) EMORY  
UNIV ATLANTA GA DEPT OF CHEMISTRY G NELSON ET AL.  
85 AUG 87 EMORY/DC/TR/18 N00014-83-K-0026

1/1

UNCLASSIFIED

F/G 7/4

NL



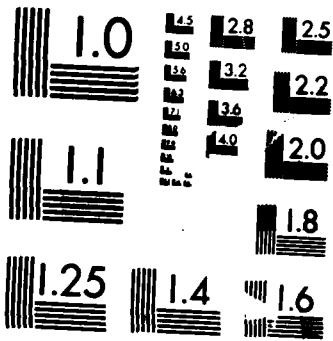

MICROCOPY RESOLUTION TEST CHART  
 NATIONAL BUREAU OF STANDARDS-1963-A

UNCLASSIFIED

1a. REPORT SECURITY CLASSIFICATION

AD-A183 403

2a. SECURITY CLASSIFICATION AUTHORITY

2b. DECLASSIFICATION/DOWNGRADING SCHEDULE

**S E U**  
AUG 12 1987  
CSD

3. DISTRIBUTION/AVAILABILITY OF REPORT

Approved for public release: distribution unlimited.

4. PERFORMING ORGANIZATION REPORT NUMBER(S)

Emory/DC/TR/18

5. MONITORING ORGANIZATION REPORT NUMBER(S)

6a. NAME OF PERFORMING ORGANIZATION

Emory University

6b. OFFICE SYMBOL (if applicable)

7a. NAME OF MONITORING ORGANIZATION

Office of Naval Research  
Chemistry Program

6c. ADDRESS (City, State, and ZIP Code)

Department of Chemistry  
Atlanta, GA 30322

7b. ADDRESS (City, State, and ZIP Code)

800 N. Quincy St.  
Arlington, VA 22217

8a. NAME OF FUNDING/SPONSORING ORGANIZATION

Office of Naval Research

8b. OFFICE SYMBOL (if applicable)

9. PROCUREMENT INSTRUMENT IDENTIFICATION NUMBER

N00014-83-K-0026

8c. ADDRESS (City, State, and ZIP Code)

10. SOURCE OF FUNDING NUMBERS

PROGRAM ELEMENT NO.	PROJECT NO.	TASK NO.	WORK UNIT ACCESSION NO.
		NR 051-841	

11. TITLE (Include Security Classification)

A Versatile Interface for Instrument Control

12. PERSONAL AUTHOR(S)

M. Thomas, G. Nelson, G. Patonay and I.M. Warner

13a. TYPE OF REPORT  
Technical

13b. TIME COVERED  
FROM TO

14. DATE OF REPORT (Year, Month, Day)  
August 5, 1987

15. PAGE COUNT  
8

16. SUPPLEMENTARY NOTATION

Accepted for publication in Laboratory Microcomputer

17. COSATI CODES

FIELD	GROUP	SUB-GROUP

18. SUBJECT TERMS (Continue on reverse if necessary and identify by block number)

Computer control, microprocessor interfacing, parallel and serial data handling, fluorescence lifetime, fluorescence detected circular dichroism

19. ABSTRACT (Continue on reverse if necessary and identify by block number)

An inexpensive interface which uses Zilog Z-80 microprocessor compatible interface chips and allows instrumental control and data acquisition using a Radio Shack TRS-80 Model 4 microcomputer is described. This interface provides parallel and serial data handling capabilities useful to a wide variety of instrumentation. A block diagram of the TRS-80 compatible interface is presented and the TTL signals which are used for chip selection, control and input/output functions are discussed. Examples of the application of this interface to a commercial Photochemical Research Associates fluorescence lifetime instrument and an in-house, multidimensional fluorescence detected circular dichroism spectrometer are provided.

20. DISTRIBUTION/AVAILABILITY OF ABSTRACT

UNCLASSIFIED/UNLIMITED  SAME AS RPT.  DTIC USERS

21. ABSTRACT SECURITY CLASSIFICATION

UNCLASSIFIED

22a. NAME OF RESPONSIBLE INDIVIDUAL  
Isiah M. Warner

22b. TELEPHONE (Include Area Code)  
(404) 727-6623

22c. OFFICE SYMBOL

OFFICE OF NAVAL RESEARCH

Contract N00014-83-K-0026

R&T Code No. 4131001

TECHNICAL REPORT NO. 18

A Versatile Interface for Instrument Control

by

M. Thomas, G. Nelson, G. Patonay and I.M. Warner

Accepted for Publication

in Laboratory Microcomputer

Emory University  
Department of Chemistry  
Atlanta, Georgia 30322

August 5, 1987

Accession For	
NTIS CRA&I	<input checked="" type="checkbox"/>
DTIC TAB	<input type="checkbox"/>
Unannounced	<input type="checkbox"/>
Justification .....	
By .....	
Distribution/	
Availability Codes	
Dist	Avail and/or Special
A-1	

Reproduction in whole or in part is permitted for any purpose of the United States Government.

This document has been approved for public release and sale; its distribution is unlimited.



87 8 11 005

## INTRODUCTION

The trend in modern instrumentation is computerization and automation. Most new commercial instruments are provided with input/output ports for control and data collection. This control is designed to be provided through compatible data stations. Instruments developed in the research laboratory may also utilize components which may be computer controlled. The cost of providing instrument control in such situations can be very large, yet the versatility and expandability of the control units is usually limited.

We describe here an expanded interface based on a Tandy TRS-80 microcomputer<sup>1</sup>. This interface can provide parallel and serial data handling capabilities useful to a wide variety of instrumentation. The TRS-80 is a Z-80A CPU based microcomputer which may use as much as 128 kilobytes of random access memory. The TRS-80 can support one to four 5.25" floppy disk drives and comes equipped with a serial port and communications software. This microcomputer is a very good choice for an intelligent interface, since several useful data storage and transfer functions have already been implemented. The TRS-80 also supports a wide variety of programming languages, including assembly language, Basic, and Pascal.

Examples of the application of this interface to a commercial Photochemical Research Associates Fluorescence Lifetime Instrumentation (London, Ontario, Canada), and an in-house, multidimensional fluorescence detected circular dichroism spectrometer are provided. These applications demonstrate the

versatility of the basic interface design presented here.

### INTERFACE DESIGN

The interface described here may be cheaply and easily constructed from double sided copper clad boards and electronics artwork supplies. Connecting the interface to the microcomputer is simple since the major signals from the TRS-80 to the peripheral parallel (PIO) and serial (SIO) interface chips are available through a 50 pin I/O connector on the CPU motherboard<sup>2</sup>.

Four address lines are used by the interface to control the selection of peripheral devices. Addresses 80H to FFH are reserved for system use. Care must therefore be taken to insure that these addresses are not assigned to a peripheral device. Address line A7 is used to enable a 74LS138 3-8 decoder demultiplexer for peripheral chip selection. Address lines A4-A6 are used to select which of eight possible interface chips are enabled. The selection of control and data bytes passed to the peripheral interface chips is made by address line A1. Each PIO and SIO contain two data channels which are selected by address line A0. This addressing scheme provides a total of eight peripheral devices or sixteen data channels. With 128 out of 256 possible Z-80 input/output ports available on the TRS-80, the number of data channels could be increased by further address line decoding. Each port is accessible through the OUT and INPUT Z-80 machine code commands.

In addition, as diagrammed in the schematic in Figure 1, the eight chip enable outputs are gated through a 74LS30 8 input positive NAND gate. This output is then NAND gated with the

logical NAND of the 50 pin I/O IN and OUT signals by a 74LS00 positive NAND gate. This signal is sent through the I/O bus as the EXIOSEL for the I/O port. The recoding of the chip enable lines is necessary only for input operations from the peripheral devices. The microcomputer will not relinquish control of the data bus without EXIOSEL.

Eight data lines are also available from the I/O connector. These lines carry eight bit information to and from the PIO and SIO interface chips. These lines are driven by buffers in the TRS-80, so no drivers are needed for the interface board. However, it is best to minimize distance from the I/O connector to the interface chips to decrease noise on the connecting cable.

Other signals which are required for PIO and SIO operation are M1 and RESET. These signals are directly input as SIO control signals. The logical AND of these signals is input to the M1 on the PIO using a 74LS08. Several signals needed to drive Z-80 peripheral devices are not provided on the I/O connector. A clock signal to control PIO and SIO timing, RD and IORQ signals for I/O operations are needed. These signals are supplied to the interface by soldering wires to the appropriate pins of the Z-80 microprocessor.

The Z-80 system PIO<sup>3</sup> has two eight bit parallel I/O ports on each chip. Therefore, sixteen bit numbers can be input or output from the interface using only one chip. Each port has handshaking lines which can be used to control the transfer of data to and from the PIO. Port B on the PIO chip has a driver circuit capable of supplying 1.5mA at 1.5V to drive Darlington

transistors. We have no difficulty in sending information over distances of up to ten feet using either port A or port B. Beyond this distance, line drivers and receivers may be needed to insure that interfacing cables do not pick up noise.

The Z-80 SIO<sup>3</sup> also contains two serial I/O ports which can transmit up to eight bit data and the desired number of parity and stop bits. The output baud rate is generated by an external clock signal input to the SIO chip. This signal may be generated by constructing a circuit to divide the microprocessor clock to an appropriate frequency. We accomplish this using an Intersil ICM7240 programmable timer/counter and an 74LS93 4-bit binary counter. This signal may be further divided by software control of the SIO. The number of data and stop bits, parity, and generation of modem control signals are all set through control bytes output to the SIO. The SIO has an extensive command library. Also, I/O buffering of up to three characters is also provided along with several status registers.

Although the hardware design shown in Figure 1 is not designed for interrupts, the Z-80 interface chips may be easily configured to service mode 1 Z-80 interrupts. Hardware considerations in this event require that the interrupt enable (IEI) line from the peripheral chip with the highest priority be connected to the chip interrupt enable of the chip of next highest priority to create a "daisy chain". The Z-80 microprocessor must be setup in the proper mode to allow interrupts and an interrupt vector must be supplied by software to service the interrupt routines.



In some cases, some of the control lines from the Z-80 microprocessor and TRS-80 I/O connector must be filtered to remove spurious signals from the lines. This may be accomplished using simple RC circuits with time constants in the hundreds of nanoseconds. We found the need for these filters was different for each interface built in our laboratory.

All chips on the interface board require 5 volt power supply and ground. The power supply for the TRS-80 is not designed to support additional peripheral boards. However, simple 5 volt power supplies are easy to construct and may be activated from the TRS-80 main power switch. It is also necessary to maintain logical ground between the TRS-80 and the interface described here.

#### APPLICATIONS

FDCD. The TRS-80 and interface system has been used to control a multidimensional fluorescence detected circular dichroism (FDCD) spectrophotometer<sup>4</sup>. This instrument is a special type of fluorometer which acquires fluorescence information as a function of multiple excitation and emission wavelengths as well as excitation polarization. The computer controls the acquisition, transfer and some mathematical manipulation of 512 data points read from a diode array detector system each second through the interface. Since the data volume is high, the interface must work fast. Assembly language routines allow the development of very fast data acquisition and manipulation programs.

The interface system must also control several I/O functions necessary to operate the spectrophotometer. Figure 2 shows the

peripheral devices that are included in the instrument. These devices must send and receive eight and sixteen bit data between the microcomputer, stepper motor controllers, and the fluorescence detector. The TRS-80 performs several mathematical calculations on the data as it is acquired. For example, the data from repetitive scans of the diode array detector are signal averaged to increase the signal to noise ratio for the measurement. Additionally, the 512 data points for each scan are spectrally averaged by the microcomputer to 32 data points. The data is then sent over a sixteen bit parallel interface to a Hewlett Packard 9845B minicomputer where it is permanently stored and displayed as isometric projections or contour plots. Figure 3 shows a typical fluorescence detected circular dichroism spectrum for the drug salicylic acid when it is bound to human serum albumin protein.

**Fluorescence Lifetime.** The interface described here has also been used to automate a Photochemical Research Associates fluorescence lifetime instrument as shown in Figure 4. The experimental data is collected by this instrument in a Tracor Northern TN-7200 multichannel analyzer (MCA). The MCA is equipped with a RS-232 serial remote control option and an additional serial port for data output. The operation of the MCA is fully controlled through the Z-80 SIO on the interface. In addition, excitation and emission wavelength, sample holder positioning, and lamp aperture are selected by stepper motor controllers. These controllers are operated through the interface PIO chips. Finally, the fluorescence rate of the

sample is read from a photon counter equipped with a parallel BCD output. This data is read by a PIO and converted to binary representation.

The data from the MCA is recorded by the TRS-80 on diskette. These data files are transferred to a MicroVax II minicomputer via a standard TRS-80 serial port. This port is used to log onto and transfer the TRS-80 file to the MicroVax. Each data file has VAX VMS commands embedded which create a file on the MicroVax and store it on disk. The data are analyzed using a computation intensive non-linear least squares curve fitting routine.

#### CONCLUSION

The interface described in this paper may be utilized in a variety of ways. The number of serial and parallel I/O channels can be tailored for many laboratory data collection situations. The hardware considerations are straightforward and sophisticated instrument control software algorithms can be developed and implemented. The total cost of such a system is less than \$1500 for the microcomputer and electronic component parts. The use of an inexpensive microcomputer-based interface allows one general interface design to service a variety of computer data acquisition and control needs. The flexibility of such a design offers a useful solution to changing laboratory interface needs and may easily be used as a universal laboratory interface.

#### ACKNOWLEDGEMENTS

We acknowledge The National Science Foundation (grant CHE-8210886) and Office of Naval Research for support of this research. Gregory Nelson acknowledges support from an American

Chemical Society Analytical Division Summer Fellowship sponsored  
by the Society of Analytical Chemists of Pittsburgh. I. M.  
Warner acknowledges support from a Presidential Young  
Investigator Award (CHE-8351675).

1. G. Nelson, G. Patonay, I. M. Warner, *Anal. Instrum.*, 15, 215-225 (1986).
2. *TRS-80 Model 4/4P Technical Reference Manual*, Tandy Corporation, Fort Worth, Texas (1982).
3. *Zilog 1982/83 Data Book*, Zilog, Inc., Campbell, California (1982)
4. M. P. Thomas, G. Patonay, I. M. Warner, *Rev. Sci. Instrum.*, 57, 1308-1313 (1986).

**FIGURE CAPTIONS**

1. Block diagram of TRS-80 compatible interface.
2. Block diagram of TRS-80 interfaced to a fluorescence detected circular dichroism spectrophotometer.
3. Isometric multidimensional projection of the FDCD spectrum of salicylic acid bound to human serum albumin protein.
4. Block diagram of TRS-80 interface coupled to PRA Lifetime Instrumentation.

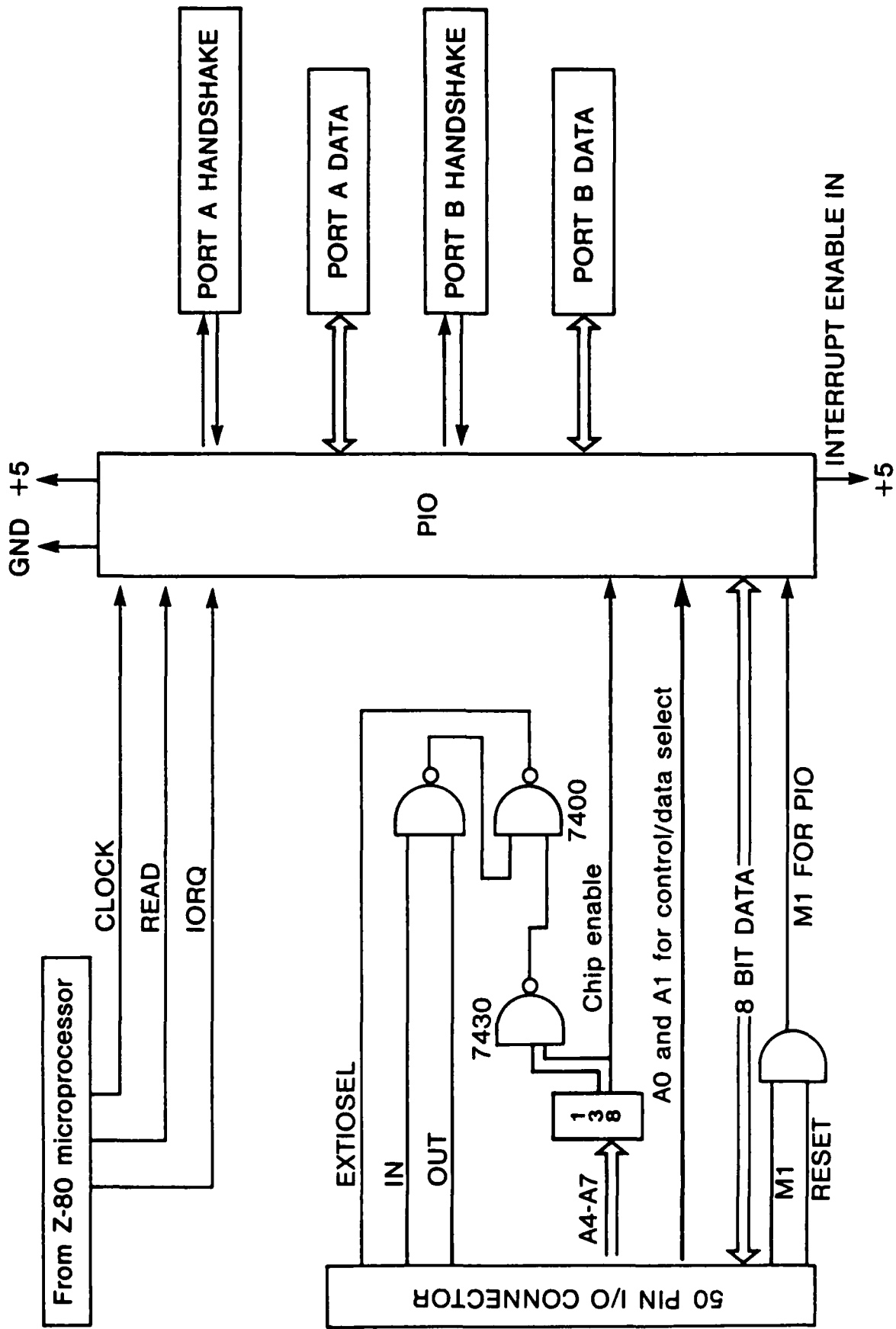

Figure 1.

Block diagram of TRS-80 compatible interface.

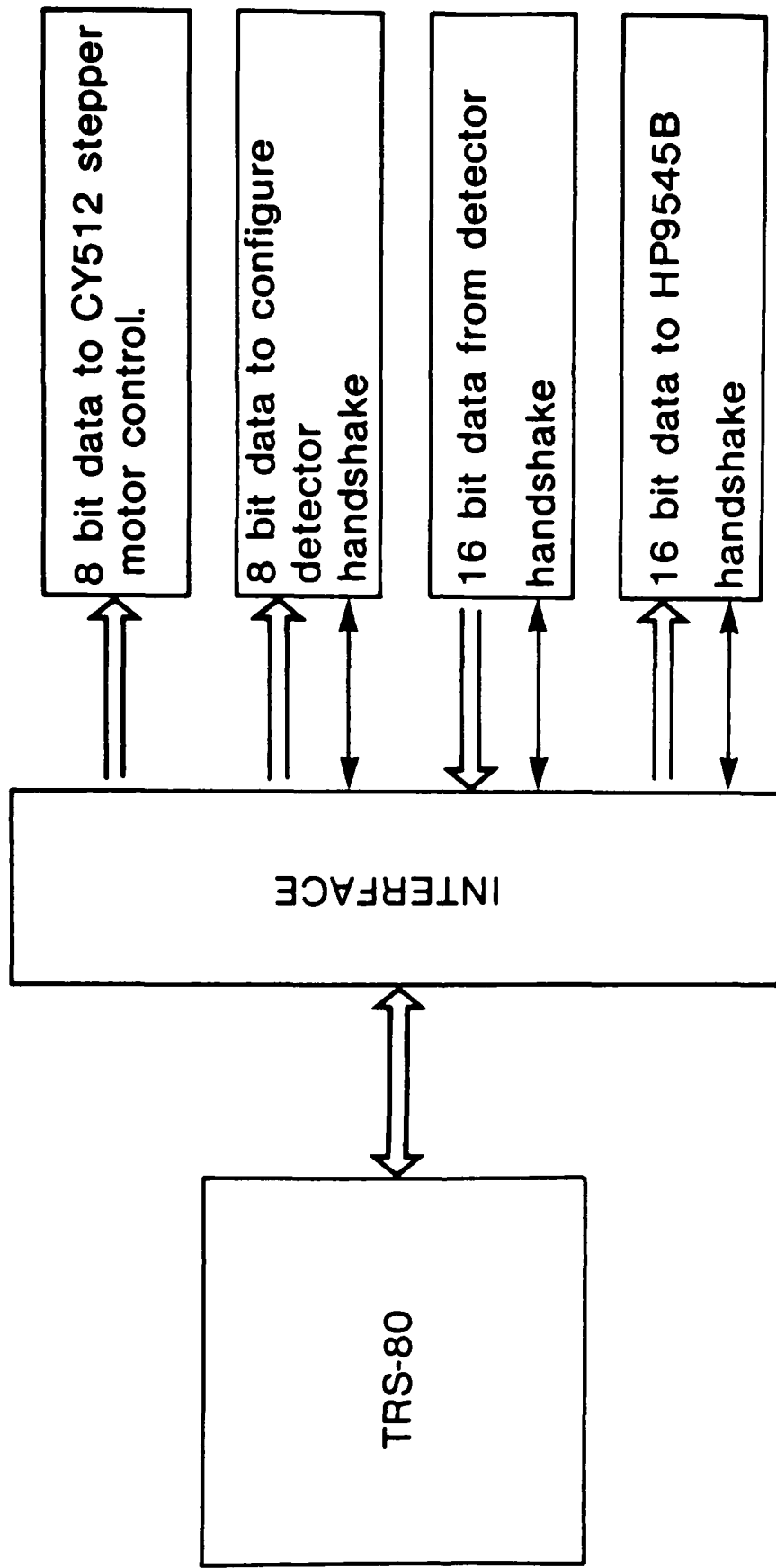

Figure 2.

Block diagram of TRS-80 interfaced to a fluorescence detected circular dichroism spectrophotometer.



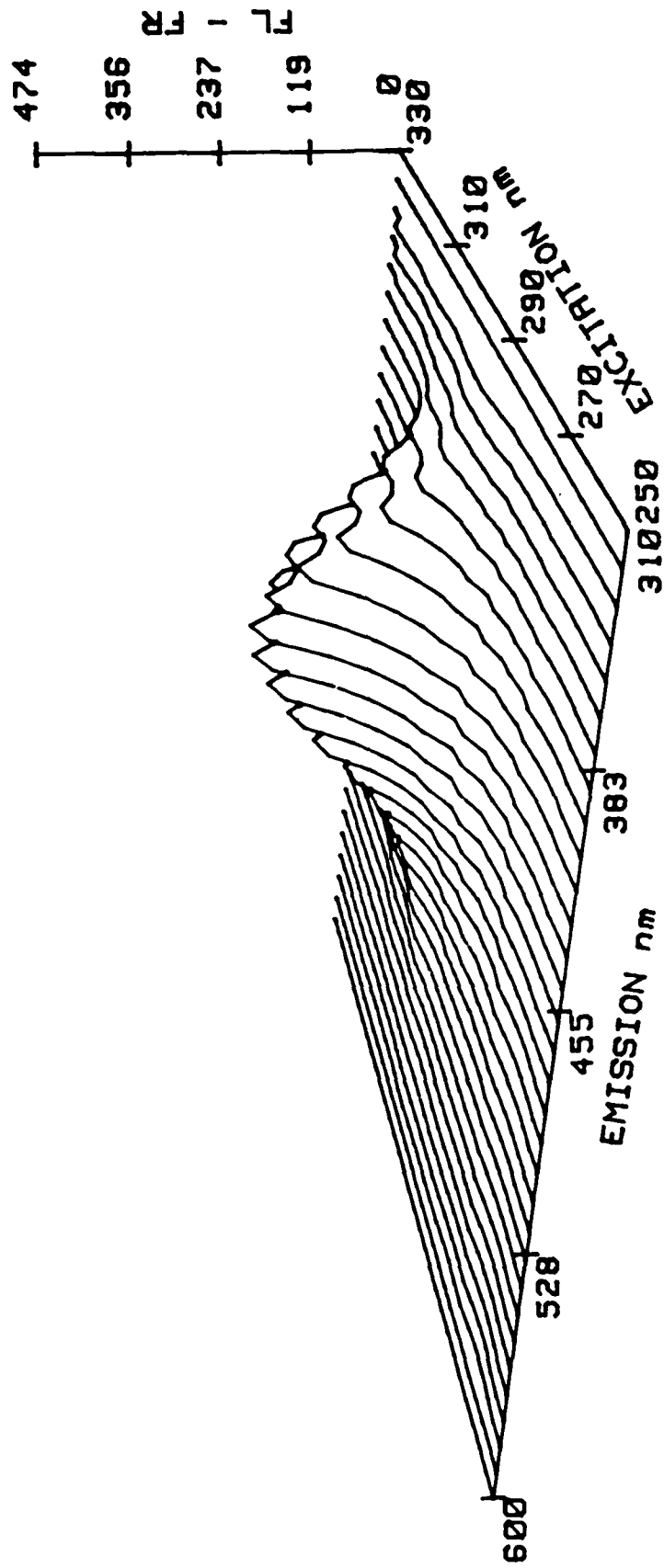

Figure 3.

Isometric multidimensional projection of the FDCD spectrum of salicylic acid bound to human serum albumin protein.

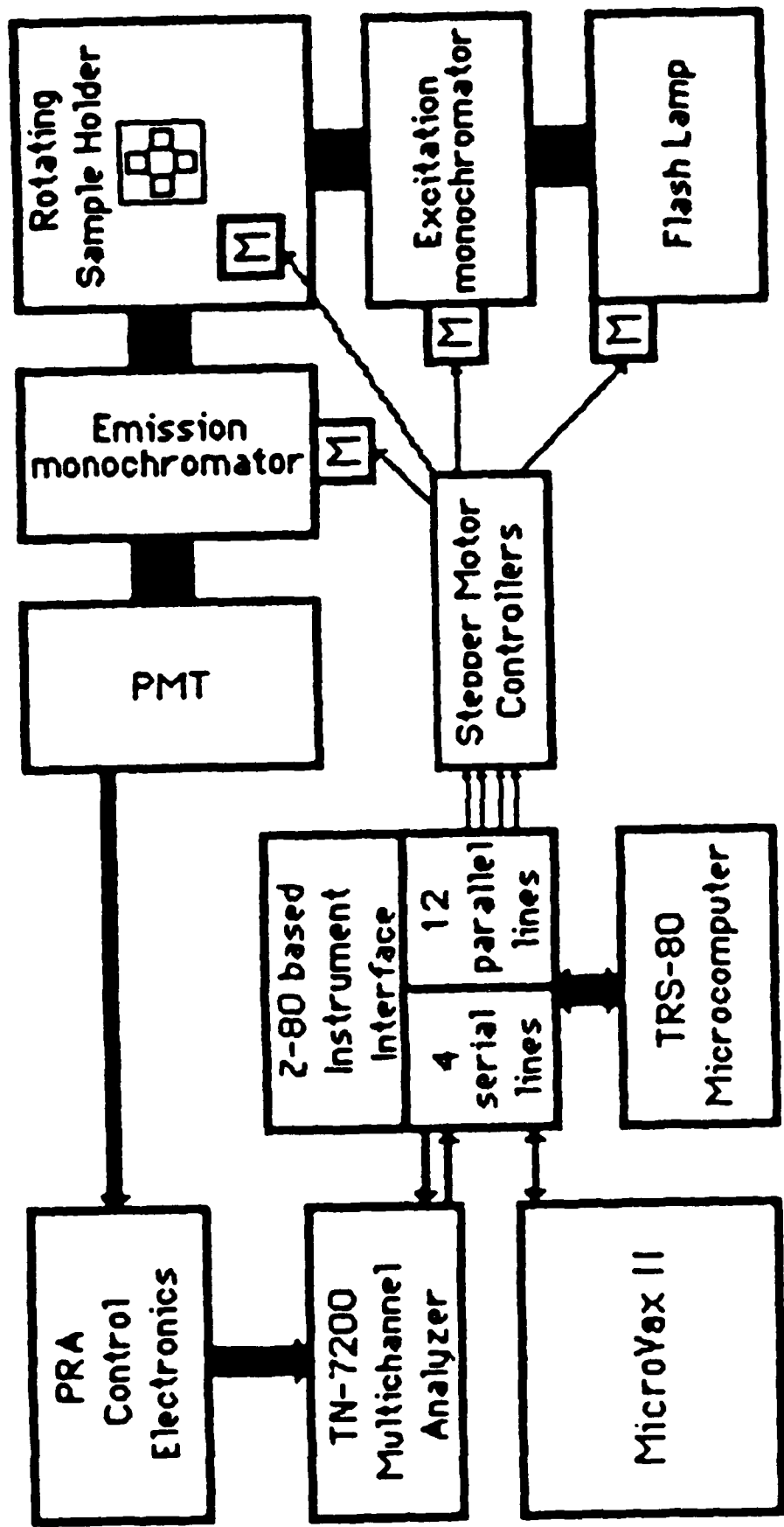

Figure 4.

Block diagram of TRS-80 interface coupled to PRA lifetime instrumentation.

TECHNICAL REPORT DISTRIBUTION LIST, GEN

	<u>No. Copies</u>		<u>No. Copies</u>
Office of Naval Research Attn: Code 1113 800 N. Quincy Street Arlington, Virginia 22217-5000	2	Dr. David Young Code 334 NORDA NSTL, Mississippi 39529	1
Dr. Bernard Duda Naval Weapons Support Center Code 50C Crane, Indiana 47522-5050	1	Naval Weapons Center Attn: Dr. Ron Atkins Chemistry Division China Lake, California 93555	1
Naval Civil Engineering Laboratory Attn: Dr. R. W. Drisko, Code L52 Port Hueneme, California 93401	1	Scientific Advisor Commandant of the Marine Corps Code RD-1 Washington, D.C. 20380	1
Defense Technical Information Center Building 5, Cameron Station Alexandria, Virginia 22314	12 high quality	U.S. Army Research Office Attn: CRD-AA-IP P.O. Box 12211 Research Triangle Park, NC 27709	1
DTNSRDC Attn: Dr. H. Singerman Applied Chemistry Division Annapolis, Maryland 21401	1	Mr. John Boyle Materials Branch Naval Ship Engineering Center Philadelphia, Pennsylvania 19112	1
Dr. William Tolles Superintendent Chemistry Division, Code 6100 Naval Research Laboratory Washington, D.C. 20375-5000	1	Naval Ocean Systems Center Attn: Dr. S. Yamamoto Marine Sciences Division San Diego, California 91232	1

END

9-87

Dtic