

AD-A183 363

THE TREATMENT OF NONHOMOGENEOUS DIRICHLET BOUNDARY  
CONDITIONS BY THE P-V.E. (U) MARYLAND UNIV COLLEGE PARK  
INST FOR PHYSICAL SCIENCE AND TECH. I BABUSKA ET AL.

1/1

UNCLASSIFIED

APR 87 BW-1063 N00014-85-K-0169

F/G 12/1

NL

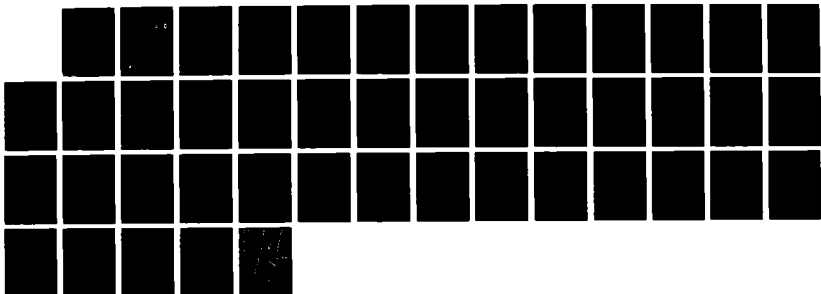

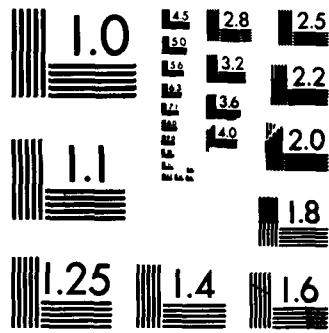

MICROCOPY RESOLUTION TEST CHART  
NATIONAL BUREAU OF STANDARDS-1963-A

15

DTIC FILE COPY

AD-A183 363

  
MARYLAND  
COLLEGE PARK CAMPUS

DTIC  
ELECTE  
AUG 14 1987  
S D  
D

THE TREATMENT OF NONHOMOGENEOUS DIRICHLET BOUNDARY CONDITIONS  
BY THE p-VERSION OF THE FINITE ELEMENT METHOD

I. Babuška and Manil Suri

Technical Note BN-1063

April 1987

DISTRIBUTION STATEMENT  
Approved for public release  
Distribution unlimited

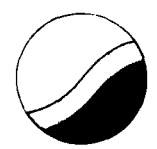

INSTITUTE FOR PHYSICAL SCIENCE  
AND TECHNOLOGY

87  
87 1 29 000

SECURITY CLASSIFICATION OF THIS PAGE (When Data Entered)

REPORT DOCUMENTATION PAGE		READ INSTRUCTIONS BEFORE COMPLETING FORM
1. REPORT NUMBER Technical Note BN-1063	2. GOVT ACCESSION NO. ADA183363	3. RECIPIENT'S CATALOG NUMBER
4. TITLE (and Subtitle) THE TREATMENT OF NONHOMOGENEOUS DIRICHLET BOUNDARY CONDITIONS BY THE p-VERSION OF THE FINITE ELEMENT METHOD	5. TYPE OF REPORT & PERIOD COVERED Final life of the contract	
	6. PERFORMING ORG. REPORT NUMBER	
7. AUTHOR(s) I. Babuska and Manil Suri	8. CONTRACT OR GRANT NUMBER(s) ONR N00014-85-K-0169 AFOSR 85-0322	
9. PERFORMING ORGANIZATION NAME AND ADDRESS Institute for Physical Science and Technology University of Maryland, College Park, MD 20742 & Dept. of Mathematics, UMBC, Catonsville, MD 21228	10. PROGRAM ELEMENT, PROJECT, TASK AREA & WORK UNIT NUMBERS	
11. CONTROLLING OFFICE NAME AND ADDRESS Department of the Navy Office of Naval Research Arlington, VA 22217	12. REPORT DATE April 1987	
	13. NUMBER OF PAGES 42	
14. MONITORING AGENCY NAME & ADDRESS (if different from Controlling Office)	15. SECURITY CLASS. (of this report)	
	15a. DECLASSIFICATION/DOWNGRADING SCHEDULE	
16. DISTRIBUTION STATEMENT (of this Report)  Approved for public release: distribution unlimited		
17. DISTRIBUTION STATEMENT (of the abstract entered in Block 20, if different from Report)		
18. SUPPLEMENTARY NOTES		
19. KEY WORDS (Continue on reverse side if necessary and identify by block number)		
20. ABSTRACT (Continue on reverse side if necessary and identify by block number) → The paper addresses the problem of the implementation of nonhomogeneous essential Dirichlet type boundary conditions in the p-version of the finite element method. ←		

DD FORM 1 JAN 73 1473

EDITION OF 1 NOV 65 IS OBSOLETE  
S/N 0102-LF-014-6601

SECURITY CLASSIFICATION OF THIS PAGE (When Data Entered)

THE TREATMENT OF NONHOMOGENEOUS DIRICHLET BOUNDARY CONDITIONS  
 BY THE p-VERSION OF THE FINITE ELEMENT METHOD



I. Babuška<sup>1</sup>  
 Institute for Physical Science and Technology  
 University of Maryland, College Park, MD 20742

Manil Suri<sup>2</sup>  
 University of Maryland Baltimore County  
 Catonsville, Maryland 21228

Accession For	
NTIS CRA&I	<input checked="" type="checkbox"/>
DTIC TAB	<input type="checkbox"/>
Unannounced	<input type="checkbox"/>
Justification	
By	
Distribution/	
Availability Codes	
DTIC	
A-1	

<sup>1</sup>Partially supported by the Office of Naval Research under Grant N-00014-85-K-0169.

<sup>2</sup>Research partially supported by the Air Force Office of Scientific Research, Air Force Systems Command, USAF, under Grant Number AFOSR 85-0322.

**ABSTRACT**

The paper addresses the problem of the implementation of nonhomogeneous essential Dirichlet type boundary conditions in the p-version of the finite element method.

## 1. INTRODUCTION

A recent addition to the field of finite element analysis has been the development of the  $p$  and  $h$ - $p$  versions of the finite element method. For two-dimensional problems the  $p$  and  $h$ - $p$  versions have been implemented in the commercial system PROBE by Noetic Tech., St. Louis with a first release in 1985 and the second in 1986 [13]. The three-dimensional commercial finite element code FIESTA having some  $p$ -version capabilities had been developed at ISMES (Istituto Sperimentali Modelli e Strutture) in Bergamo, Italy, and has been available since 1980 in the United States. An implementation of the three-dimensional  $p$  and  $h$ - $p$  versions for the Cray computers is presently being done at the Aeronautical Research Institute of Sweden (Flygtekniska Försöksanstalten-FFA) [1] and by Noetic Tech.

The  $p$  and  $h$ - $p$  versions are being used very successfully today in industry. See, for example [8]. A survey of today's state of the art may be found in [3] where pertinent references are given. For basic theoretical results we refer to [4], [5], [6], [10], [11]. For some implementational and engineering aspects, we refer, for example, to [8], [14], [15].

An important part of any code in finite element analysis is the problem of imposing nonhomogeneous essential boundary conditions of Dirichlet type. We addressed this question, among others, in [5] for the two dimensional problem. Our technique was implemented in PROBE - Release 2, and tested very successfully. In [5] we assumed that the nonhomogeneous boundary conditions had slightly higher smoothness than the minimal possible one, namely we assumed that the boundary data belongs to  $H_k(\Gamma)$ ,  $k > 1$  (instead of minimally  $k > \frac{1}{2}$ ). With this assumption we obtained an optimal error estimate. There are some indications that for  $\frac{1}{2} < k < 1$  the method proposed

in [5] could lead to a loss in the convergence rate and that for  $k < 3/4$  there exist boundary conditions for which convergence may not be achieved at all.

This paper proposes an implementation which guarantees convergence for all  $k > 1/2$ . We get the almost optimal estimate

$$\|u - u_p\|_{H^1(\Omega)} \leq C p^{-(k-1/2)} \log^{1/2} p \|u\|_{H^{k+1/2}(\Omega)}.$$

In addition, we discuss some other possible methods for imposing the nonhomogeneous boundary conditions of Dirichlet type. In a forthcoming paper we will discuss general boundary conditions with partial constraints for systems of equations. Such conditions are important in the theory of elasticity, for example.



## 2. PRELIMINARIES

### 2.1. NOTATION

Let  $\mathbb{R}^2$  denote the usual Euclidean space with  $x = (x_1, x_2) \in \mathbb{R}^2$ . By  $\Omega \subset \mathbb{R}^2$  we denote a bounded Lipschitzian domain with piecewise smooth boundary  $\partial\Omega = \Gamma = \bigcup_{i=1}^n \bar{\Gamma}_i$  where  $\Gamma_i$  are smooth (open) arcs. The end points  $A_i$ ,  $i = 1, \dots, n$  of  $\Gamma_i$  will be called the vertices of  $\Omega$ . For fixing the ideas we will restrict ourselves to simply connected Lipschitzian domains although our results hold in general. We will also consider  $\Omega \subset \mathbb{R}^1$ , i.e.,  $\Omega = I = (a, b)$ .

Let  $L_2(\Omega) = H^0(\Omega)$ ,  $H^k(\Omega)$ ,  $H_0^k(\Omega)$ ,  $k \geq 0$  denote the usual Sobolev spaces. For  $u \in H^k(\Omega)$  we denote by  $\|u\|_{H^k(\Omega)}$  and  $|u|_{H^k(\Omega)}$  the usual norm and seminorm, respectively. For  $k > 0$  not an integer, we define  $H^k(\Omega)$  and  $| \cdot |_{H^k(\Omega)}$  by the K-method of the theory of interpolation ([9], [12])

$$H^{l+\theta}(\Omega) = (H^l(\Omega), H^{l+1}(\Omega))_{\theta, 2}$$

$$0 < \theta < 1, \quad l + \theta = k, \quad l \text{ integer.}$$

The norm is defined accordingly, i.e., with

$$(2.1a) \quad K(u, t) = \inf_{\substack{v \in H^l(\Omega), w \in H^{l+1}(\Omega) \\ v+w=u}} (|v|_{H^l(\Omega)} + t |w|_{H^{l+1}(\Omega)})$$

we define

$$(2.1b) \quad |u|_{H^{l+\theta}(\Omega)} = \left( \int_0^\infty t^{-\theta} K(u, t)^2 \frac{dt}{t} \right)^{\frac{1}{2}}.$$

Analogously we define  $H_0^k(\Omega) = (H_0^l(\Omega), H_0^{l+1}(\Omega))_{\theta, 2}$  ( $k$  a noninteger) with the norm  $|u|_{H_0^{l+\theta}(\Omega)}$ .

We will be especially interested in the one dimensional case.

Let  $\Omega = I = (-1,1)$ . Then we define  $\|u\|_{H^k(I)}$  and  $\|u\|_{H_0^k(I)}$  by

(2.1b) for  $k$  a noninteger. For  $k \neq \text{integer} + \frac{1}{2}$ , we have for  $u \in H_0^k(I)$

$$(2.2) \quad \|u\|_{H_0^k(I)} = \|u\|_{H^k(I)}$$

where by  $=$  we denote the equivalency of norms.

For  $k = \text{integer} + \frac{1}{2}$  we have

$$(2.3) \quad \|u\|_{H_0^{\mu+\frac{1}{2}}(I)}^2 = \left( \|u\|_{H^{\mu+\frac{1}{2}}(I)}^2 + \left\| (1-x^2)^{-\frac{1}{2}} \frac{d^\mu u}{dx^\mu} \right\|_{H^0(I)}^2 \right).$$

This space is often denoted by  $H_{00}^{\mu+\frac{1}{2}}(I)$  in the literature and we will use this notation as well. Analogous results are true for general  $\Omega$ .

Now let  $\mathcal{H}$  be the space of  $2\pi$ -periodic functions. For  $u \in \mathcal{H}$  we will write

$$(2.4) \quad u(\xi) = \sum_{j=0}^{\infty} a_j \cos j \xi + \sum_{j=1}^{\infty} b_j \sin j \xi.$$

Then we define  $H^k$  and  $\|\cdot\|_{H^k}$  by (2.1a) and (2.1b) as before. We have then

$$(2.5) \quad \|u\|_{H^k} = \left[ \sum_{j=0}^{\infty} a_j^2 (1+j^2)^k + \sum_{j=1}^{\infty} b_j^2 (1+j^2)^k \right]^{\frac{1}{2}}.$$

Moreover, if  $a_j, b_j$  are such that the right hand side of (2.5) is finite, then  $u \in H^k$  and the norm  $\|u\|_{H^k}$  is defined by (2.5).

For  $I$  an open interval or straight line segment, we denote by  $s$  the length parameter. Then we define  $H^k(I)$ ,  $H_0^k(I)$ ,  $\|u\|_{H^k(I)}$ ,  $\|u\|_{H_0^k(I)}$  as before with respect to  $s$ .

So far we considered only spaces of scalars. We define now  $(H^k(\Omega))^m$

with  $u \in (H^k(\Omega))^m$ ,  $u = (u_1, \dots, u_m)$ ,  $u_i \in H^k(\Omega)$  and

$$\|u\|_{(H^k(\Omega))^m} = \left( \sum_{i=1}^m \|u_i\|_{H^k(\Omega)}^2 \right)^{1/2} \text{ and analogously } \|\cdot\|_{(H_0^k(\Omega))^m}, \text{ etc.}$$

By  $C^{(k)}(\Omega)$ , respectively  $C^{(k)}(\bar{\Omega})$ , we denote the space of all functions with continuous derivatives of order  $k \geq 0$  ( $k$  integer) on  $\Omega$ , respectively  $\bar{\Omega}$ .

The set of all algebraic polynomials of degree (total) less than or equal to  $p$  on  $\Omega$  will be denoted by  $P_p^1(\Omega)$ . By  $P_p^2(\Omega)$  we will denote the set of all polynomials of degree less than or equal to  $p$  in each variable on  $\Omega$ . For  $\Gamma \subset \mathbb{R}^2$  a straight segment, we define  $P_p(\Gamma)$  as the set of polynomials on  $\Gamma$  of degree less than or equal to  $p$  in  $s$  and by  $P_p^0(\Gamma)$  we denote the set of polynomials vanishing at the end points of  $\Gamma$ .

Let  $I = (-1, 1)$ . Then we will deal with two different polynomial bases on  $I$ :

- a) The Chebyshev polynomials  $T_k(x) = \cos(k \cos^{-1}(x))$ ,  $k = 0, 1, 2, \dots$
- b) The integrals of Legendre polynomials  $P_k(x)$ ,

$$\psi_k(x) = (2k-1) \int_{-1}^x P_{k-1}(t) dt = P_k(x) - P_{k-2}(x), \quad k = 2, 3, \dots$$

Obviously the set  $\{T_k\}$ ,  $k = 0, 1, \dots, p$  is a basis of  $P_p(I)$  and  $\{\psi_k\}$ ,  $k = 2, \dots, p$  is a basis of  $P_p^0(I)$ .

## 2.2. THE MODEL PROBLEM

Let  $H = (H^1(\Omega))^m$ ,  $H_0 = (H_0^1(\Omega))^m$ , and let  $B(u, v)$ ,  $u = (u_1, \dots, u_m) \in H$ ,  $v = (v_1, \dots, v_m) \in H$  be a continuous symmetric bilinear form on  $H \times H$  satisfying

$$(2.6) \quad B(u,u) \geq \gamma |u|_{H^1(\Omega)}^2, \quad \gamma > 0$$

for any  $u \in H_0$ . Further, let  $F$  be a continuous linear functional on  $H$ .

Let on  $\bar{\Gamma}_i$  the matrices  $A_i(s) = \{\alpha_{k,l}^{[i]}(s)\}$ ,  $k, l = 1, \dots, m$ ,  $i = 1, \dots, n$  of smooth functions be given. We shall assume that the matrices  $A_i$  are nonsingular. Further, let  $g^{[i]} = \{g_k^{[i]}\}$ ,  $k = 1, \dots, m$ ,  $i = 1, \dots, n$  be a function defined on  $\Gamma_i$ . We will say that  $g = \{g^{[i]}\} \in (H^{1/2}(\Gamma))^m$  if there is a  $U \in (H^1(\Omega))^m$  such that  $g = U|_{\Gamma}$ .

Let now  $h = \{h^{[i]}\}$ ,  $i = 1, \dots, n$  be such that with  $g^{[i]} = A_i^{-1}(s)h^{[i]}$ ,  $g = \{g^{[i]}\} \in (H^{1/2}(\Gamma))^m$ . Then our problem is:

Find  $u_0 \in (H^1(\Omega))^m$  such that

$$(2.7) \quad \begin{aligned} \alpha) \quad & A_i u_0|_{\Gamma_i} = h^{[i]} = A_i g^{[i]} \\ \beta) \quad & B(u_0, v) = F(v), \quad \forall v \in H_0 = (H_0^1(\Omega))^m. \end{aligned}$$

Because of the assumptions, the problem has a unique solution.

Remark 2.1. We could obviously transform  $\alpha$ ) into  $u_0|_{\Gamma_i} = A_i^{-1}h^{[i]} = g^{[i]}$ ,  $i = 1, \dots, n$  and assume that  $A_i$  is a unit matrix. Nevertheless, our formulation is more general and computationally natural. For example, in elasticity theory, although we formulate the problem in displacement components  $u, v$  (in directions of the axes  $x_1, x_2$ ), we prescribe the conditions for displacement in the direction of the normal and the tangent to the boundary.

From the general theory of interpolated spaces and our assumptions about  $A_i$ , we obviously have  $h^{[i]} \in H^{1/2}(\Gamma_i)$ .

So far we have assumed that the Dirichlet boundary conditions are given

on the entire boundary. Nevertheless our theory can be easily generalized when on one part of the boundary  $u_0$  is not constrained.

### 2.3. THE p-VERSION OF THE FINITE ELEMENT METHOD

Let us assume that domain  $\Omega$  has been partitioned into curved rectangles and triangles (see Fig. 2.1).

Let  $\bar{\Omega} = \bigcup_{i=1}^q \bar{\Omega}_i$  where  $\Omega_i$  are (open) curved quadrilaterals or triangles called elements of the partition of  $\Omega$ . The vertices of  $\Omega_i$  are called the nodes of the partition. We will assume that the vertices of  $\Omega$  are nodes of the partition.

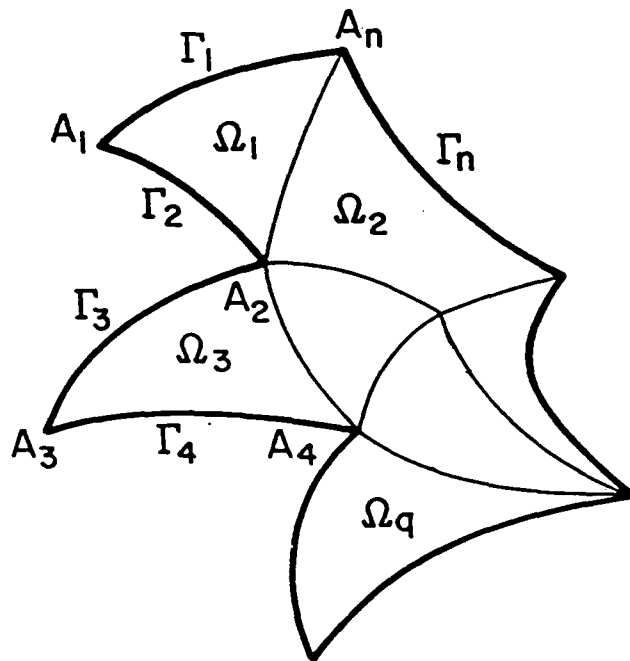

Fig. 2.1. The scheme of the partitioned domain.

By  $S = (-1, 1)^2$  and  $T = \{\xi, \eta \mid 0 < \eta < (\xi+1)\sqrt{3}, -1 < \xi \leq 0; 0 < \eta < (1-\xi)\sqrt{3}, 0 \leq \xi < 1\}$  (see Fig. 2.2), we denote the standard square and

standard triangle.

Assume that the mappings  $F_j := (x_i^{[j]} = x_i^{[j]})(\xi, \eta)$ ,  $i = 1, 2$ ,  $j = 1, \dots, q$  map  $\bar{S}$  on  $\bar{\Omega}_j$  if  $\Omega_j$  is a quadrilateral and  $\bar{T}$  on  $\bar{\Omega}_j$  if  $\Omega_j$  is a triangle. Let  $F_j, F_j^{-1}$  be smooth one-to-one mappings. Then we can speak about the vertices and sides of  $\Omega_j$  in an obvious way.

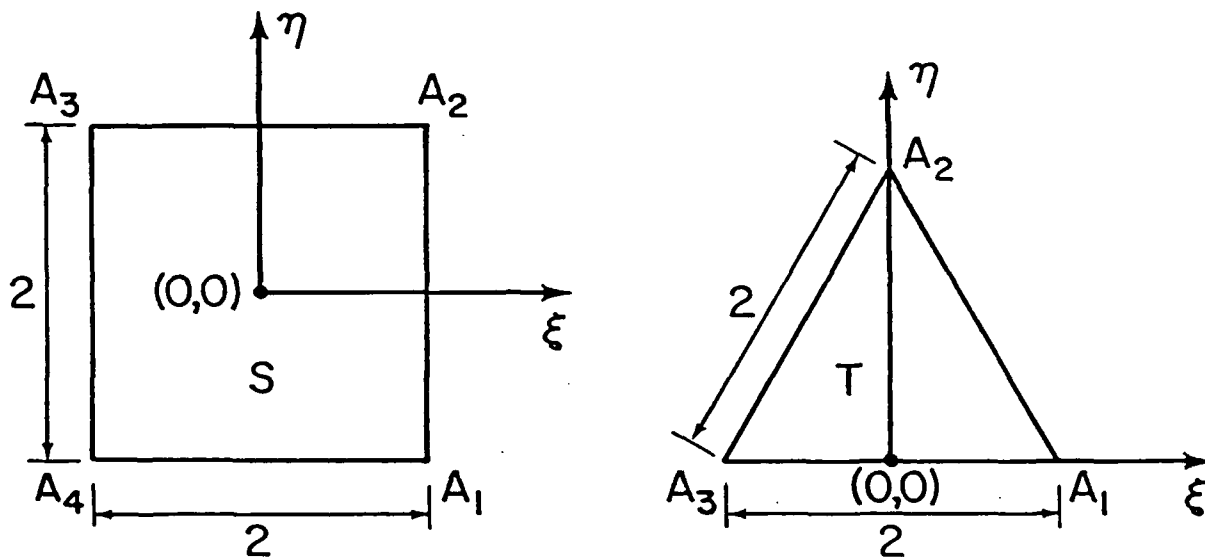

Fig. 2.2. The scheme of  $S$  and  $T$ .

We will assume the following

i) The intersection  $\bar{\Omega}_i \cap \bar{\Omega}_j$  is either empty or is the single common vertex of  $\Omega_i$  and  $\Omega_j$  or the single entire side of  $\Omega_i$  and  $\Omega_j$ .

ii) If  $\bar{\Omega}_i \cap \bar{\Omega}_j = \Gamma_{i,j}$  and  $P \in \Gamma_{i,j}$ ,  $P = F_i(P_i) = F_j(P_j)$ ,  $P_i \in \overline{A_k A_{k+1}}$ ,  $P_j \in \overline{A_l A_{l+1}}$  then  $d(P_i, A_k) = d(P_j, A_l)$  or  $d(P_j, A_{l+1})$ , where we denote by  $d(P_i, A_j)$  the Euclidean distance between  $P_i$  and  $A_j$ . Hence we can also identify  $\Gamma_{i,j}$  with  $I = (-1, 1)$  and the map  $F_i^* = F_j^* = F_{i,j}^*$  of

I onto  $\Gamma_{1,j}$ , where the relation between  $F_1$  and  $F_{1,j}^*$  is obvious (realizing that the sides of T and S have length 2).

Let now  $P_p(\Omega) = \{u \in H^1(\Omega) \mid u(F_1^{-1}(x_1, x_2)) \in P_p^1(T) \text{ if } \Omega_1 \text{ is a curvilinear triangle, } u(F_1^{-1}(x_1, x_2)) \in P_p^2(S) \text{ if } \Omega_1 \text{ is a quadrilateral}\}$ .

Further, we denote

$$P_p^m(\Omega) = (P_p(\Omega))^m \text{ and } u_p = (u_{p,1}, \dots, u_{p,m})^T.$$

Let  $u_p \in P_p^m(\Omega)$ , then  $u_{p,k}(F^{-1}(x_1, x_2))$ ,  $k = 1, 2, \dots, m$ , is obviously a polynomial of degree p on every side of T, respectively S. We will identify the sides of T, respectively S, with  $I = (-1, 1)$  in the obvious way. Assume now that a projection mapping  $\overset{\circ}{P}_p$  is given which maps  $H^k(I)$ ,  $k > \frac{1}{2}$  onto  $P_p(I)$  with  $(\overset{\circ}{P}_p u)(\pm 1) = u(\pm 1)$  and  $\overset{\circ}{P}_p u = u$  if  $u \in P_p(I)$ . We remark that  $H^k(I) \hookrightarrow C(\bar{I})$  for  $k > \frac{1}{2}$  and hence  $u(\pm 1)$  is well defined.

The p-version of the finite element method for solving our model problem consists of finding  $u_p \in P_p^m(\Omega)$  such that

$$(2.8) \quad \begin{aligned} \alpha) \quad u_p &= \overset{\circ}{P}_p g \text{ on } \Gamma_1 \\ \beta) \quad B(u_p, v) &= F(v), \quad \forall v \in P_p^m(\Omega) \cap (H_0^1(\Omega))^m. \end{aligned}$$

Obviously the method strongly depends on the choice of the projection  $\overset{\circ}{P}_p$ . This choice can be influenced by various factors like accuracy, implementation, the type of problems to be solved, their formulation, etc. For example, the matrices  $A_1$  in the model formulation in Section 2.2 can be used in (2.8) $\alpha$  instead. The main part of this paper consists of analyzing some choices of this projection.

### 3. THE PROJECTIONS $\overset{\circ}{P}_p$

#### 3.1. THE PROJECTION $\overset{\circ}{P}_p^{1/2}$ AND ITS BASIC PROPERTIES

In this section we will introduce projection operator  $\overset{\circ}{P}_p^{1/2}$ , respectively  $\overset{\circ}{P}_p^{1/2, A}$ , of  $H^k(I)$ , respectively  $(H^k(I))^m$ , onto  $P_p(I)$ , respectively  $P_p^m(I)$ .

We prove first

Lemma 3.1. Let  $I = (-1, 1)$  and  $\hat{I} = (0, \pi) = F^{-1}(I)$  where  $F(\xi) = \cos \xi$ ,  $\xi \in \hat{I}$ . For  $u(x)$ ,  $x \in I$ , let  $\hat{u}(\xi)$ ,  $\xi \in \hat{I}$  be such that  $u(\cos \xi) = \hat{u}(\xi)$ . Then for any  $u \in H^k(I)$ ,  $k \geq \frac{1}{2}$ , we have

$$(3.1) \quad c_1 |\hat{u}|_{H^{1/2}(\hat{I})} \leq |u|_{H^{1/2}(I)} \leq c_2 |\hat{u}|_{H^{1/2}(\hat{I})}$$

$$(3.2) \quad |u|_{H^k(I)} \geq C(k) |\hat{u}|_{H^k(\hat{I})}$$

where  $0 < C_1 < C_2$  and  $C(k)$  are independent of  $u$ .

Proof. Let  $S_0 = \{z = x+iy \mid |x| \leq 1, 0 \leq y < 1\}$  and  $Q = \{\zeta = \xi + i\eta \mid \cos \zeta \in S_0\}$ . (See Fig. 3.1).

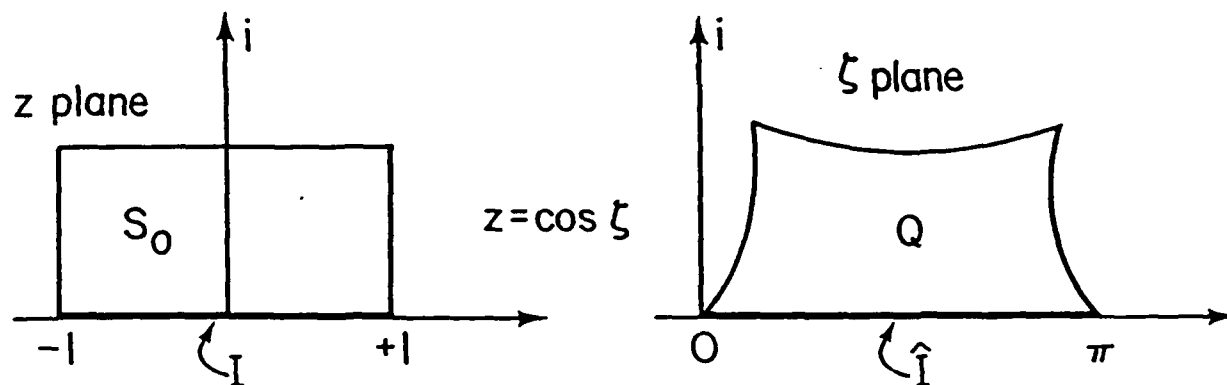

Fig. 3.1. The rectangle  $S_0$  and its image  $Q$ .



Let  $u \in H^{1/2}(I)$ . Then there exists  $U \in H^1(S_0)$  such that  
 $|u|_{H^1(S_0)} \leq C|u|_{H^{1/2}(I)}$  and  $U|_I = u$ . Let  $V(\xi) = U(\cos \xi)$ . Then

$$|v|_{H^1(Q)} = |u|_{H^1(S_0)}$$

and also

$$|v|_{H^1(Q)} \leq C|u|_{H^1(S_0)}$$

Hence, by the imbedding theorem we have with  $v = v|_{\hat{I}}$ ,

$$|\hat{u}|_{H^{1/2}(\hat{I})} = |v|_{H^{1/2}(\hat{I})} \leq C|v|_{H^1(Q)} \leq C|u|_{H^1(S_0)} \leq C|u|_{H^{1/2}(I)}$$

where  $C$  is independent of  $u$ . The inequality

$$|u|_{H^{1/2}(I)} \leq C|\hat{u}|_{H^{1/2}(\hat{I})}$$

can be proven analogously by changing the role of  $S_0$  and  $Q$ . Hence (3.1) is proven.

Let us prove (3.2) for  $k = 1$ . We have

$$\begin{aligned} \left| \frac{d\hat{u}}{d\xi} \right|_{H^0(\hat{I})}^2 &= \int_0^\pi \left( \frac{d\hat{u}}{d\xi} \right)^2 d\xi = \int_{-1}^{+1} \left( \frac{du}{dx} \right)^2 \sqrt{1-x^2} dx \\ &\leq \int_{-1}^{+1} \left( \frac{du}{dx} \right)^2 dx = \left| \frac{du}{dx} \right|_{H^0(I)}^2. \end{aligned}$$

Hence

$$\begin{aligned} |\hat{u}|_{H^1(\hat{I})}^2 &\leq \left| \frac{d\hat{u}}{d\xi} \right|_{H^0(\hat{I})}^2 + |\hat{u}|_{H^0(\hat{I})}^2 \\ &\leq \left| \frac{du}{dx} \right|_{H^0(I)}^2 + C|\hat{u}|_{H^{1/2}(\hat{I})}^2 \end{aligned}$$

$$\leq \|u\|_{H^1(I)}^2 + C \|u\|_{H^{1/2}(I)}^2 \leq C \|u\|_{H^1(I)}^2.$$

In the same way we prove the inequality for  $k > 1$ ,  $k$  integer. For  $k \geq \frac{1}{2}$  nonintegral the inequality follows from the standard interpolation theorem.  $\square$

Let  $u \in H^k(I)$ ,  $k \geq \frac{1}{2}$ . Then

$$\int_{-1}^{+1} \frac{1}{(1-x^2)^{1/2}} u^2 dx < \infty$$

and we can write

$$(3.3) \quad u(x) = \sum_{j=0}^{\infty} a_j T_j(x)$$

where  $T_j(x)$  are Chebyshev polynomials.

We define

i) for  $u \in H^k(I)$ ,  $k \geq \frac{1}{2}$

$$(3.4a) \quad P_p^{1/2} u = \sum_{j=0}^p a_j T_j(x) \in P_p(I)$$

ii) for  $u \in H^k(I)$ ,  $k > \frac{1}{2}$

$$(3.4b) \quad P_p^{1/2} u = P_p^{1/2} u + \bar{u}$$

where  $\bar{u}$  is linear on  $\bar{I}$  and  $(P_p^{1/2} u)(\pm 1) = u(\pm 1)$ .

Theorem 3.2. Let  $u \in H^k(I)$ . Then for  $k \geq \frac{1}{2}$

$$(3.5a) \quad \|u - P_p^{1/2} u\|_{H^{1/2}(I)} \leq C(k) p^{-(k-1/2)} \|u\|_{H^k(I)}$$

and for  $k > \frac{1}{2}$

$$(3.5b) \quad \left| u - \frac{p^{1/2}}{p} u \right|_{H^{1/2}(I)} \leq C(k) p^{-(k-1/2)} \|u\|_{H^k(I)}$$

$$(3.5c) \quad \left| u - \frac{p^{1/2}}{p} u \right|_{H_{00}^{1/2}(I)} \leq C(k) p^{-(k-1/2)} \log^{1/2} p \|u\|_{H^k(I)}$$

The constant  $C$  in (3.5a,b,c) is independent of  $u$  and  $p$  but depends on  $k$ .

Proof. Let  $\bar{u}(\xi) = u(\cos \xi)$ . Then  $\bar{u} \in H$  is an even  $2\pi$ -periodic function and

$$(3.6a) \quad \bar{u}(\xi) = \sum_{l=0}^{\infty} u_l \cos l\xi$$

$$(3.6b) \quad \bar{u}_p = \left( \frac{p^{1/2}}{p} u \right) = \sum_{l=0}^p u_l \cos l\xi.$$

This immediately yields (using (3.2) and (2.5))

$$(3.7) \quad \begin{aligned} \|\bar{u} - \bar{u}_p\|_{H^{1/2}(\hat{I})}^2 &= \sum_{p+1}^{\infty} |u_l|^2 (1+l^2)^{1/2} \\ &\leq C \left( \frac{1}{p+1} \right)^{2(k-1/2)} \sum_{l=p+1}^{\infty} |u_l|^2 (1+l^2)^k \leq C p^{-2(k-1/2)} \|\bar{u}\|_{H^k(\hat{I})}^2 \\ &\leq C p^{-2(k-1/2)} \|u\|_{H^k(I)}^2. \end{aligned}$$

Using (3.1) we get (3.5a).

For  $k > 1/2$

$$(3.8) \quad \begin{aligned} |(\bar{u} - \bar{u}_p)(x)| &\leq \sum_{j=p+1}^{\infty} |u_j| \leq \sum_{j=p+1}^{\infty} |u_j| (1+j^2)^{\frac{k}{2}} (1+j^2)^{-\frac{k}{2}} \\ &\leq \left( \sum_{j=p+1}^{\infty} |u_j|^2 (1+j^2)^k \right)^{1/2} \left( \sum_{j=p+1}^{\infty} (1+j^2)^{-k} \right)^{1/2} \leq C(k) p^{-(k-1/2)} \|\bar{u}\|_{H^k(\hat{I})} \end{aligned}$$

and hence

$$\|u - \frac{p^{1/2}}{p} u\|_{H^{1/2}(I)} \leq C(k)p^{-(k-1/2)} \|u\|_{H^k(I)}$$

and (3.5b) is proven.

Let us prove now (3.5c) for  $k > 1/2$  using (2.3). We have to show that

$$(3.10) \quad \left[ \int_{-1}^{+1} (u - \frac{p^{1/2}}{p} u)^2 (1-x^2)^{-1} dx \right]^{1/2} \leq Cp^{-(k-1/2)} \log^{1/2} p \|u\|_{H^k(I)}$$

which is equivalent to showing

$$(3.11) \quad \left[ \int_0^\pi (u - \frac{p^{1/2}}{p} u)^2 (\sin \xi)^{-1} d\xi \right]^{1/2} \leq Cp^{-(k-1/2)} \log^{1/2} p \|u\|_{H^k(I)}$$

Let us first observe that

$$(3.12) \quad \widetilde{(u - \frac{p^{1/2}}{p} u)} = \sum_{j=\lfloor \frac{p+2}{2} \rfloor}^{\infty} u_{2j} (\cos 2j\xi - 1) + \sum_{j=\lfloor \frac{p+1}{2} \rfloor}^{\infty} u_{2j+1} (\cos(2j+1)\xi - \cos \xi)$$

where by [a] we denote the integral part of a. Hence

$$\begin{aligned} \int_0^\pi \widetilde{(u - \frac{p^{1/2}}{p} u)^2} (\sin \xi)^{-1} d\xi &\leq 2 \left[ \int_0^\pi \left( \sum_{j=\lfloor \frac{p+2}{2} \rfloor}^{\infty} u_{2j} (\cos 2j\xi - 1) \right)^2 \frac{1}{\sin \xi} d\xi \right. \\ &\quad \left. + \int_0^\pi \left( \sum_{j=\lfloor \frac{p+1}{2} \rfloor}^{\infty} u_{2j+1} (\cos(2j+1)\xi - \cos \xi) \right)^2 \frac{1}{\sin \xi} d\xi \right] \\ &\leq 8 \left[ \int_0^\pi \left( \sum_{j=\lfloor \frac{p+2}{2} \rfloor}^{\infty} u_{2j} \sin^2 j\xi \right)^2 \frac{1}{\sin \xi} d\xi \right. \end{aligned}$$

$$\begin{aligned}
& + \int_0^\pi \left( \sum_{j=\lfloor \frac{p+1}{2} \rfloor}^{\infty} |u_{2j+1}| \sin(j+1)\xi \sin j\xi \right)^2 \frac{1}{\sin \xi} d\xi \\
\leq & C \int_0^\pi \left[ \left( \sum_{j=\lfloor \frac{p+2}{2} \rfloor}^{\infty} |u_{2j}| (1+j^2)^{k/2} \frac{(j\xi)^{\varepsilon_1(\xi)} (j(\pi-\xi))^{\varepsilon_2(\xi)} |\sin j\xi|^{2-\varepsilon_1(\xi)-\varepsilon_2(\xi)}}{(1+j^2)^{k/2}} \right)^2 \right. \\
& \left. + \left( \sum_{j=\lfloor \frac{p+1}{2} \rfloor}^{\infty} |u_{2j+1}| (1+j^2)^{\frac{k}{2}} \frac{(j\xi)^{\varepsilon_1(\xi)} (j(\pi-\xi))^{\varepsilon_2(\xi)} |\sin j\xi|^{2-\varepsilon_1(\xi)-\varepsilon_2(\xi)}}{(1+j^2)^{\frac{k}{2}}} \right)^2 \right] \frac{1}{\sin \xi} d\xi \\
\leq & C p^{-2(k-\frac{1}{2})} \left[ \int_0^\pi \xi^{\frac{2\varepsilon_1(\xi)}{p}} \frac{\xi^{2\varepsilon_2(\xi)} (\pi-\xi)^{2(\varepsilon_1(\xi)+\varepsilon_2(\xi))}}{\sin \xi} d\xi \right] \|u\|_{H^k(I)}^2
\end{aligned}$$

$$\text{for } 0 \leq \varepsilon_1(\xi) < \frac{2k-1}{4} = 2\varepsilon.$$

Choose

$$\varepsilon_1(\xi) = \varepsilon \text{ on } [0, \frac{1}{p}], = 0 \text{ otherwise}$$

$$\varepsilon_2(\xi) = \varepsilon \text{ on } [\pi - \frac{1}{p}, \pi], = 0 \text{ otherwise.}$$

Then we obtain

$$\begin{aligned}
\leq & C p^{-2(k-\frac{1}{2})} \left[ p^{2\varepsilon} \int_0^{\frac{1}{p}} \xi^{2\varepsilon-1} d\xi + \int_{\frac{1}{p}}^{\pi-\frac{1}{p}} (\sin \xi)^{-1} d\xi + p^{2\varepsilon} \int_{\pi-\frac{1}{p}}^\pi (\pi-\xi)^{2\varepsilon-1} d\xi \right] \|u\|_{H^k(I)}^2 \\
\leq & C p^{-2(k-\frac{1}{2})} \log p \|u\|_{H^k(I)}^2.
\end{aligned}$$

This proves (3.11). (3.5c) follows from (3.5b) and (2.3).  $\square$

Remark 3.1. The necessity of the term  $\log \frac{1}{p}$  in (3.5c) is an open question.

Remark 3.2. For  $u \in H^k(I)$  with  $k > \frac{1}{2}$ , we may prove (analogously to (3.7))

$$(3.13) \quad \|\bar{u} - \bar{u}_p\|_{H^l(\hat{I})}^2 \leq C p^{-2(k-l)} \|u\|_{H^k(I)}^2, \quad \frac{1}{2} \leq l < k.$$

Theorem 3.3. Let  $u \in P_p(I)$ ,  $u(\pm 1) = 0$ . Assume that  $\|u\|_{H^{\frac{1}{2}}(I)} \leq A$ ,  $\|u\|_{C^0(I)} \leq A$ . Then

$$(3.14) \quad \|u\|_{H_{00}^{\frac{1}{2}}(I)} \leq CA \log^{\frac{1}{2}} p.$$

Proof. As before we have

$$\bar{u} = \sum_{j=0}^{\lfloor \frac{p-1}{2} \rfloor} b_{2j} (\cos 2j\xi - 1) + \sum_{j=0}^{\lfloor \frac{p-1}{2} \rfloor} b_{2j+1} (\cos(2j+1)\xi - \cos \xi)$$

and

$$\sum_{j=0}^{\lfloor \frac{p-1}{2} \rfloor} b_j^2 (1+j^2)^{\frac{1}{2}} \leq A.$$

To prove (3.14) we have to show that

$$\int_0^\pi \frac{\bar{u}^2}{\sin \xi} d\xi \leq C \log p A^2.$$

We have analogously as before for  $\epsilon_1 = \epsilon$  on  $[0, \frac{1}{p}]$ ,  $= 0$  otherwise,  $\epsilon_2 = \epsilon$  on  $[\pi - \frac{1}{p}, \pi]$ ,  $= 0$  otherwise,  $\epsilon > 0$

$$\begin{aligned} \int_0^\pi \frac{\bar{u}^2}{\sin \xi} d\xi &\leq C \left[ \int_{\frac{1}{p}}^{\pi - \frac{1}{p}} \frac{1}{\sin \xi} d\xi \|u\|_{C^0(\hat{I})}^2 + p^{2\epsilon} \frac{1}{p^{2\epsilon}} \|\bar{u}\|_{H^{\frac{1}{2}}(\hat{I})}^2 \right] \\ &\leq C \log p A^2. \end{aligned}$$

Let us generalize the operator  $P_p^{\frac{1}{2}}$ . Assume that for  $x \in I$ ,

$0 < \bar{\alpha}_0 \leq \alpha(x) \leq \bar{\alpha}_1 < \infty$ . Let  $u \in H^k(I)$ ,  $k \geq \frac{1}{2}$ . Then we define  $P_p^{\frac{1}{2}, \alpha}$ , respectively  $\bar{P}_p^{\frac{1}{2}, \alpha}$ , as follows:

for  $k \geq \frac{1}{2}$ :

$$(3.15a) \quad P_p^{\frac{1}{2}, \alpha} (P_p^{\frac{1}{2}, \alpha} u) = P_p^{\frac{1}{2}, \alpha} (\alpha u),$$

for  $k > \frac{1}{2}$ :

$$(3.15b) \quad \bar{P}_p^{\frac{1}{2}, \alpha} u = P_p^{\frac{1}{2}, \alpha} u + \bar{u}$$

where  $\bar{u}$  is linear and  $(\bar{P}_p^{\frac{1}{2}, \alpha} u)(\pm 1) = u(\pm 1)$ .

We will show that (3.15a) and (3.15b) uniquely define  $P_p^{\frac{1}{2}, \alpha}$  and  $\bar{P}_p^{\frac{1}{2}, \alpha}$ .

Let

$$u(x) = \sum_{j=0}^{\infty} u_j T_j(x)$$

$$\alpha(x) = \sum_{j=0}^{\infty} a_j T_j(x)$$

and

$$(3.16) \quad u_p(x) = P_p^{\frac{1}{2}, \alpha} u = \sum_{j=0}^p b_j T_j(x).$$

Then using (3.6) we have

$$(3.17a) \quad \bar{u}(\xi) = \sum_{j=0}^{\infty} u_j \cos j\xi,$$

$$(3.17b) \quad \bar{\alpha}(\xi) = \sum_{j=0}^{\infty} a_j \cos j\xi,$$

$$(3.17c) \quad \bar{u}_p(\xi) = \bar{P}_p^{\frac{1}{2}, \alpha} \bar{u} = \sum_{j=0}^p b_j \cos j\xi$$

where  $\{b_j\}$  are determined from the system of  $p + 1$  linear equations

$$(3.18) \quad \int_{-\pi}^{+\pi} \left[ \left( \sum_{j=0}^{\infty} a_j \cos j\xi \right) \left( \sum_{j=0}^p b_j \cos j\xi \right) \right] \cos l\xi \, d\xi \\ = \int_{-\pi}^{+\pi} \left( \sum_{j=0}^{\infty} a_j \cos j\xi \right) \left( \sum_{j=0}^{\infty} u_j \cos j\xi \right) \cos l\xi \, d\xi, \quad l = 0, 1, \dots, p.$$

We have

$$(3.19) \quad \left( \sum_{j=0}^{\infty} a_j \cos j\xi \right) \left( \sum_{j=0}^{\infty} u_j \cos j\xi \right) = \sum_{j=0}^{\infty} c_j \cos j\xi$$

where

$$c_0 = \frac{1}{2} \left[ a_0 u_0 + \sum_{k=0}^{\infty} a_k u_k \right] \\ c_j = \frac{1}{2} \left[ \sum_{k=0}^j a_{j-k} u_k + \sum_{k=0}^{\infty} a_{j+k} u_k + \sum_{k=j}^{\infty} a_{k-j} u_k \right].$$

By (3.15), (3.17c) and (3.18) we see that  $\bar{u}_p(\xi)$  is such that

$$(3.20) \quad P_p^{1/2} \alpha u_p = P_p^{1/2} \alpha u.$$

Let  $\underline{u} = \{u_k\}^T$ ,  $\underline{\alpha} = \{\alpha_k\}^T$ ,  $\underline{b} = \{b_k\}^T$ ,  $\underline{c} = \{c_k\}^T$ ,  $k = 0, 1, \dots$ . Let  $\ell_2 = \{\underline{a} = \{a_k\}^T, k = 0, 1, \dots, \|\underline{a}\|_{\ell_2}^2 = \sum_0^{\infty} a_k^2 < \infty\}$ . Since  $\bar{a}$  is bounded, for any  $\underline{u} \in \ell_2$  we have  $\underline{c} \in \ell_2$  and we can write

$$(3.21) \quad \underline{c} = A(\alpha) \underline{u}$$

where  $A(\alpha)$  is the infinite matrix with coefficients stemming from (3.19).

Matrix  $A(\alpha)$  is then a mapping of  $\ell_2$  into  $\ell_2$ . For any integer  $p \geq 0$  we denote by  $A_p(\alpha)$  the  $(p+1) \times (p+1)$  principal submatrix of  $A(\alpha)$ . By

(3.17c)  $\bar{u}_p$  can be identified by a  $(p+1)$  dimensional vector  $\underline{b} \in \mathbb{R}^{p+1}$  with



(using 3.18)

$$(3.22) \quad A_p(\alpha)\underline{b} = [\underline{c}]_{p+1}$$

where

$$[\underline{c}]_{p+1} = \{c_j\}^T, \quad j = 0, \dots, p.$$

We will now show that for any  $\underline{d} \in \mathbb{R}^{p+1}$

$$\underline{d}^T(A_p(\alpha)\underline{d}) \geq \bar{\alpha}_0(\underline{d}^T\underline{d})$$

which guarantees unique solvability of (3.22) and hence the existence of  $p_{\frac{1}{2}, \alpha}$ .

Lemma 3.4. Let  $\underline{u} = \{u_j\}^T \in \ell_2$ . Then

$$\underline{u}^T(A(\alpha)\underline{u}) \geq \bar{\alpha}_0(\underline{u}^T\underline{u}) = \bar{\alpha}_0|\underline{u}|_{\ell_2}^2.$$

Proof. Let  $\underline{u} \in \ell_2$ . Then  $\bar{u} = \sum_{j=0}^{\infty} u_j \cos j\xi \in L_2(\bar{I})$ , ( $\bar{I} = (-\pi, \pi)$ )

and

$$\int_{-\pi}^{\pi} (\bar{\alpha}\bar{u})\bar{u}d\xi = \int_{-\pi}^{\pi} \bar{\alpha}\bar{u}^2d\xi \geq \bar{\alpha}_0|\bar{u}|_{L_2(\bar{I})}^2.$$

Using this with (3.21), we get

$$(3.23) \quad \underline{u}^T A(\alpha)\underline{u} = \frac{1}{\pi} \int_{-\pi}^{\pi} \bar{u}(\bar{\alpha}\bar{u})d\xi \geq \frac{\bar{\alpha}_0}{\pi} |\bar{u}|_{L_2(\bar{I})}^2$$

which yields the Lemma. □

Corollary 3.5. Let  $\underline{a}_p \in \mathbb{R}^{p+1}$ . Then

$$\underline{a}_p^T(A_p(\alpha)\underline{a}_p) = \underline{a}_p^T(A(\alpha)\underline{a}_p) \geq \bar{\alpha}_0(\underline{a}_p^T \underline{a}_p). \quad \square$$

Corollary 3.5. shows that  $\bar{p}_p^{-1/2, \alpha} \bar{u}$  exists and is unique when  $\bar{u} \in L_2(\bar{I})$  and that

$$(3.24) \quad \|\bar{u}_p\|_{H^0(\bar{I})} \leq C \|\bar{u}\|_{H^0(\bar{I})}$$

with  $C$  independent of  $\bar{u}$ .

We now note that

$$\bar{u}^{(1)} = \frac{d\bar{u}}{d\xi} = \sum_{j=0}^{\infty} (-jb_j) \sin j\xi$$

$$(\bar{\alpha}\bar{u})^{(1)} = \frac{d(\bar{\alpha}\bar{u})}{d\xi} = \sum_{j=0}^{\infty} (-jc_j) \sin j\xi.$$

Defining the matrix  $A^{(1)}$  and the vectors  $\underline{u}^{(1)}$ ,  $\underline{c}^{(1)}$  by

$$(A^{(1)})_{j\ell} = -j(A)_{j\ell}, \quad (\underline{u}^{(1)})_j = -jb_j, \quad (\underline{c}^{(1)})_j = -jc_j,$$

we see that

$$(3.25a) \quad (\underline{c}^{(1)})_j = -j(\underline{c})_j = -j(A\underline{u})_j = (A^{(1)}\underline{u})_j$$

$$(3.25b) \quad \bar{u}^{(1)} = \sum_{j=0}^{\infty} (\underline{u}^{(1)})_j \sin j\xi$$

$$(3.25c) \quad (\bar{\alpha}\bar{u})^{(1)} = \sum_{j=0}^{\infty} (\underline{c}^{(1)})_j \sin j\xi$$

so that

$$(3.26) \quad (\underline{u}^{(1)})^T (A^{(1)}\underline{u}) = \frac{1}{\pi} \int_{-\pi}^{\pi} \bar{u}^{(1)} (\bar{\alpha}\bar{u})^{(1)} d\xi$$

Let  $|\alpha^{(1)}(x)| \leq M_1$  on  $I$ . Then for  $C_0 > \epsilon + \frac{M_1^2}{4\bar{u}_0}$ ,  $\epsilon > 0$ , it may be easily verified that

$$\int_{-\pi}^{\pi} \bar{u}^{(1)}(\bar{\alpha}\bar{u})^{(1)} d\xi + C_0 \int_{-\pi}^{\pi} \bar{u}(\bar{\alpha}\bar{u}) d\xi \geq C |\bar{u}|_{H^1(\bar{I})}^2$$

with  $C > 0$  independent of  $\bar{u}$ . Using (3.23), (3.26), this shows that

$$(\underline{u}^{(1)})^T (A^{(1)} \underline{u}) + C_0 (\underline{u})^T (A \underline{u}) \geq C \{ (\underline{u}^{(1)})^T \underline{u}^{(1)} + \underline{u}^T \underline{u} \}.$$

For  $\underline{u} = \underline{a}_p \in \mathbb{R}^{p+1}$ , this gives

$$(3.27) \quad (\underline{a}_p^{(1)})^T (A_p^{(1)} \underline{a}_p) + C_0 (\underline{a}_p^T) (A_p \underline{a}_p) \geq C \{ (\underline{a}_p^{(1)})^T \underline{a}_p^{(1)} + \underline{a}_p^T \underline{a}_p \}.$$

Using the relations (3.21), (3.22) together with (3.25) and (3.27), we obtain

$$(3.28) \quad |\bar{u}_p|_{H^1(\bar{I})} \leq C |\bar{u}|_{H^1(\bar{I})}.$$

Combining (3.24), (3.28) we get the following theorem by a standard interpolation argument

**Theorem 3.6.** Let  $0 < \bar{\alpha}_0 \leq \alpha(x) \leq \bar{\alpha}_1 < \infty$ ,  $|\alpha^{(1)}(x)| \leq M_1$ ,  $\bar{u} \in H^{\ell}(\bar{I})$ ,  $\ell \geq \frac{1}{2}$ . Then if  $u_p = P_p^{\frac{1}{2}, \alpha} u$ , for  $0 \leq k \leq \min(1, \ell)$ ,

$$|\bar{u}_p|_{H^k(\bar{I})} \leq C(k) |\bar{u}|_{H^k(\bar{I})}. \quad \square$$

**Theorem 3.7.** Let  $u \in H^k(I)$ ,  $k \geq \frac{1}{2}$ ,  $0 < \bar{\alpha}_0 \leq \alpha(x) \leq \bar{\alpha}_1 < \infty$ ,  $|\alpha^{(1)}(x)| \leq M_1$ . Then for  $k \geq \frac{1}{2}$

$$(3.29a) \quad \|u - P_p^{\frac{1}{2}, \alpha} u\|_{H^{\frac{1}{2}}(I)} \leq C(k) p^{-(k-\frac{1}{2})} \|u\|_{H^k(I)}$$

and for  $k > \frac{1}{2}$

$$(3.29b) \quad \|u - P_p^{\frac{1}{2}, \alpha} u\|_{H^{\frac{1}{2}}(I)} \leq C(k) p^{-(k-\frac{1}{2})} \|u\|_{H^k(I)}$$

(with  $u(\pm 1) = (P_p^{1/2, \alpha} u)(\pm 1)$ )

$$(3.29c) \quad \|u - P_p^{1/2, \alpha} u\|_{H_{00}^{1/2}(I)} \leq C(k) p^{-(k-1/2)} \log^{1/2} p \|u\|_{H^k(I)}.$$

Proof. Let

$$u_p = P_p^{1/2, \alpha} u$$

$$\omega = u - P_p^{1/2} u$$

$$\omega_p = P_p^{1/2, \alpha} \omega$$

Since  $P_p^{1/2} u \in P_p(I)$ , we have

$$P_p^{1/2, \alpha} (P_p^{1/2} u) = P_p^{1/2} u$$

and we see that

$$\omega_p = u_p - P_p^{1/2} u.$$

By Theorem 3.6 with  $k = 1/2$ , we have

$$\|\bar{\omega}_p\|_{H^{1/2}(\bar{I})} \leq C \|\bar{\omega}\|_{H^{1/2}(\bar{I})}$$

which gives

$$\|\bar{u}_p - \widetilde{P_p^{1/2} u}\|_{H^{1/2}(\bar{I})} \leq C \|\bar{u} - \widetilde{P_p^{1/2} u}\|_{H^{1/2}(\bar{I})}$$

so that by the triangle inequality and (3.1), we obtain

$$\|u - u_p\|_{H^{1/2}(I)} \leq C \|u - P_p^{1/2} u\|_{H^{1/2}(I)}$$

(3.5a) now yields (3.29a).

Now let  $k > 1/2$ . Then we see that using (3.8), (3.15a), for  $1/2 < l < \min(k, 1)$ ,

$$\begin{aligned}
(3.30) \quad |(\bar{\alpha}\bar{u} - \bar{\alpha}\bar{u}_p)(\xi)| &= |(\bar{\alpha}(\bar{u} - \bar{u}_p) - \bar{p}^{1/2}(\bar{\alpha}(\bar{u} - \bar{u}_p))) (\xi)| \\
&\leq C_p^{-(l-1/2)} |\bar{\alpha}(\bar{u} - \bar{u}_p)|_{H^l(\bar{I})} \\
&\leq C_p^{-(l-1/2)} |\bar{u} - \bar{u}_p|_{H^l(\bar{I})} \\
&\leq C_p^{-(l-1/2)} p^{-(k-l)} |u|_{H^k(I)}
\end{aligned}$$

using (3.13). From this, (3.29b) follows. (3.29c) will be proven analogously as before. We have

$$\bar{u} - \widetilde{\bar{p}^{1/2, \alpha} u} = \sum_{j=0}^{\infty} d_{2j} (\cos 2j\xi - 1) + \sum_{j=0}^{\infty} d_{2j+1} (\cos(2j+1)\xi - \cos \xi)$$

with

$$(3.31a) \quad \sum_{j=0}^{\infty} d_j^2 (1+j^2)^l \leq C_p^{-2(k-l)} |u|_{H^k(I)}^2, \quad k > l, 0 \leq l \leq 1$$

and

$$(3.31b) \quad |\bar{u} - \widetilde{\bar{p}^{1/2, \alpha} u}| \leq p^{-(k-1/2)} |u|_{H^k(I)}.$$

Let  $l = \min(\frac{1}{2} + \frac{k-1/2}{2}, 1) > \frac{1}{2}$ ,  $\epsilon = \frac{l-1/2}{2}$ . Then analogously as before we get

$$\int_{\frac{1}{p^2}}^{\pi - \frac{1}{p^2}} (\bar{u} - \widetilde{\bar{p}^{1/2, \alpha} u})^2 \frac{1}{\sin \xi} d\xi \leq C_p^{-(2k-1)} \log p |u|_{H^k(I)}^2$$

using (3.31b). Further

$$\int_0^{\frac{1}{p^2}} (\bar{u} - \widetilde{\bar{p}^{1/2, \alpha} u})^2 \frac{1}{\sin \xi} d\xi \leq C_p^{-2(k-l)} \int_0^{\frac{1}{p^2}} \xi^{2\epsilon-1} \left( \sum_0^{\infty} \frac{j^{2\epsilon}}{(1+j^2)^l} \right) d\xi |u|_{H^k(I)}^2$$

$$\leq C p^{-2(k-1)} p^{-4\epsilon} \|u\|_{H^k(I)}^2 = C p^{-(2k-1)} \|u\|_{H^k(I)}^2.$$

An analogous expression holds for  $\int_{\pi - \frac{1}{p}}^{\pi} \cdot d\xi$ . This proves (3.29c).  $\square$

Let on  $I$  the equation

$$(3.32) \quad \alpha u = f$$

be given with  $(\frac{f}{\alpha}) \in H^k(I)$ ,  $k \geq \frac{1}{2}$ ,  $\alpha(x) \geq \bar{\alpha}_0 > 0$ , and  $|\alpha^{(1)}(x)| \leq M_1$ . Obviously now  $u = f/\alpha$  and  $u \in H^k(I)$ . Our aim is to find  $u_p \in P_p(I)$ ,

$$(3.33) \quad u_p = \sum_{j=0}^p a_j T_j(x)$$

so that

$$(3.34a) \quad \|u - u_p\|_{H^{\frac{1}{2}}(I)} \leq C p^{-(k-\frac{1}{2})} \|u\|_{H^k(I)},$$

respectively

$$(3.34b) \quad \|u - u_p\|_{H_{00}^{\frac{1}{2}}(I)} \leq C p^{-(k-\frac{1}{2})} \log^{\frac{1}{2}} p \|u\|_{H^k(I)}.$$

We have seen that (3.34a,b) can be achieved so that  $u_p = P_p^{\frac{1}{2}}(f/\alpha)$ , respectively  $u_p = P_p^{\frac{1}{2}, \alpha}(f/\alpha)$ . The coefficients  $a_j$  in (3.33) are then determined from the conditions

$$(3.35a) \quad \int_{-1}^{+1} \frac{1}{\sqrt{1-x^2}} u_p T_j dx = \int_{-1}^{+1} \frac{1}{\sqrt{1-x^2}} \frac{f}{\alpha} T_j dx, \quad j = 0, 1, \dots, p$$

respectively

$$(3.35b) \quad \int_{-1}^{+1} \frac{1}{\sqrt{1-x^2}} \alpha u_p T_j dx = \int_{-1}^{+1} \frac{1}{\sqrt{1-x^2}} f T_j dx, \quad j = 0, 1, \dots, p,$$

and (3.34a) is achieved for  $k \geq \frac{1}{2}$ . For  $k > \frac{1}{2}$  we achieve (3.34b) so that

we can then subtract a linear function. We have used here the expansion (3.33). Of course, we can interpret (3.35) as a projection and use any basis functions which are proper for implementation. For example, we can write

$$u_p = \sum_{k=0}^p b_k \psi_k$$

where  $\psi_0 = 1$ ,  $\psi_1 = x$ , and  $\psi_k$ ,  $k \geq 2$  are as defined in Section 2.1. Then condition (3.35a) gets the form

$$\int_{-1}^{+1} \frac{1}{\sqrt{1-x^2}} u_p \psi_k dx = \int_{-1}^{+1} \frac{1}{\sqrt{1-x^2}} \frac{f}{\alpha} \psi_k dx, \quad k = 0, 1, \dots, p$$

from which coefficients  $b_k$  may be determined. (3.35b) leads to an analogous form. Instead of (3.35a), (3.35b) we can also use the transformed form

$$(3.36a) \quad \int_{-1}^{+1} \bar{u}_p \cos j\xi d\xi = \int_{-\pi}^{+\pi} \frac{\bar{f}}{\alpha} \cos j\xi d\xi, \quad j = 0, 1, \dots, p$$

respectively

$$(3.36b) \quad \int_{-\pi}^{+\pi} \bar{\alpha} \bar{u}_p \cos j\xi d\xi = \int_{-\pi}^{+\pi} \bar{f} \cos j\xi d\xi, \quad j = 0, 1, \dots, p$$

where

$$\bar{u}_p = \sum_{j=0}^p a_j \cos j\xi.$$

Fast Fourier transform techniques may now be used on (3.36).

The mapping  $P_p^{1/2, \alpha}$  can be generalized easily. Let  $A(x) = \{\alpha_{i,j}(x)\}$  be a positive definite  $n \times n$  matrix (not necessarily symmetric). Let  $u = \{u_1, \dots, u_m\} \in (H^k(I))^m$ ,  $k \geq 1/2$ . Then we define  $u_p = \{u_{p,1}, \dots, u_{p,m}\}$ ,  $u_{p,j} \in P_p(I)$ ,  $j = 1, \dots, m$ , so that

$$P_p^{1/2}(A P_p^{1/2, A} u_p) = P_p^{1/2}(A u)$$

where  $P_p^{1/2} u = (P_p^{1/2} u_1, \dots, P_p^{1/2} u_m) \in P_p^m(I)$ .  $P_p^{1/2, A}$  is defined analogously.

Theorem 3.7 immediately generalizes to

**Theorem 3.8.** Let  $|\alpha_{ij}^{(1)}(x)| \leq M_1$ . Assume further that  $y^T A y \geq \alpha_0 |y|^2$ ,  $\alpha_0 > 0$ , for any  $y = (y_1, \dots, y_m) \in R^m$ ,  $|y|^2 = \sum_{i=1}^m y_i^2$ . Then for  $k \geq 1/2$

$$(3.37a) \quad \|u - P_p^{1/2, A} u\|_{(H^{1/2}(I))^m} \leq C(k) p^{-(k-1/2)} \|u\|_{(H^k(I))^m}$$

and for  $k > 1/2$

$$(3.37b) \quad \|u - P_p^{1/2, A} u\|_{(H^{1/2}(I))^m} \leq C(k) p^{-(k-1/2)} \|u\|_{(H^k(I))^m}$$

(with  $u(\pm 1) = (P_p^{1/2, A} u)(\pm 1)$ )

$$(3.37c) \quad \|u - P_p^{1/2, A} u\|_{(H_{00}^{1/2}(I))^m} \leq C(k) p^{-(k-1/2)} \log^{1/2} p \|u\|_{(H^k(I))^m} \quad \square$$

As before, we are interested in finding  $u_p$  so that it is an approximation to the solution of

$$(3.38) \quad A u = f.$$

Theorem 3.8 gives a constructive way for the determination of  $u_p$  and provides an estimate of the accuracy obtained.

We have assumed in Theorem 3.8 that  $A$  is positive definite (although not symmetric). If  $A$  is not positive definite but becomes positive definite after permuting columns, then such an approximation having the desired properties also exists. It is sufficient to use  $P_p^{1/2, A'}$  instead of  $P_p^{1/2, A}$ , where  $A'$  is the permuted, positive definite matrix.



The positive definiteness of  $A$  is only a sufficient condition for existence of the approximation satisfying (3.37) as can be seen from the following example. Let  $\alpha_{21}$  and  $\alpha_{22}$  be constants and  $\alpha_{11}\alpha_{22} - \alpha_{12}\alpha_{21} = \omega > \omega_0 > 0$  on  $I$ . Then (3.38) gets the form

$$(3.39a) \quad \alpha_{11}(x)u_1 + \alpha_{12}(x)u_2 = f_1$$

$$(3.39b) \quad \alpha_{21}u_1 + \alpha_{22}u_2 = f_2$$

and hence (because  $\alpha_{21}$  and  $\alpha_{22}$  are constants) we get

$$(3.40) \quad \alpha_{21}u_{p,1} + \alpha_{22}u_{p,2} = p^{\frac{1}{2}} f_2.$$

Since both  $\alpha_{21}$  and  $\alpha_{22}$  cannot be zero, we may assume that  $\alpha_{22} > 0$ . Then

$$(3.41) \quad u_{p,2} = \frac{1}{\alpha_{22}} (p^{\frac{1}{2}} f_2 - \alpha_{21}u_{p,1})$$

and hence

$$(3.42) \quad p^{\frac{1}{2}} (\alpha_{11}u_{p,1}) + p^{\frac{1}{2}} (\alpha_{12}u_{p,2}) = p^{\frac{1}{2}} f_1$$

so that

$$p^{\frac{1}{2}} \left( \alpha_{11} - \frac{\alpha_{12}\alpha_{21}}{\alpha_{22}} \right) u_{p,1} = - \frac{1}{\alpha_{22}} p^{\frac{1}{2}} (\alpha_{12} p^{\frac{1}{2}} f_2) + p^{\frac{1}{2}} f_1.$$

Using the fact

$$\alpha_{11} - \frac{\alpha_{12}\alpha_{21}}{\alpha_{22}} > \frac{\omega}{\alpha_{22}} > \frac{\omega_0}{\alpha_{22}} > 0,$$

we see that  $u_{p,1}$  having the desired properties exists by Theorem 3.7. By

(3.41), we see that  $u_{p,2}$  also has the desired properties.

3.2. NUMERICAL ASPECTS OF  $P^{\frac{1}{2}}$ 

Let us consider the problem (3.38) with  $m = 2$  on  $I = (-1, 1)$

$$a_{11}u_1 + a_{12}u_2 = f_1$$

$$a_{21}u_1 + a_{22}u_2 = f_2$$

Assume that  $f_1$  and  $f_2$  are selected so that  $u_1 = |x|^{1.7}$  and  $u_2 = \cosh x |x|^{1.7}$ . We will now consider coefficients  $a_{i,j}$  of various smoothness

I) 
$$\begin{aligned} a_{11} &= \sin x, & a_{12} &= \cos x \\ a_{21} &= -\cos x, & a_{22} &= \sin x \end{aligned}$$

II) 
$$\begin{aligned} a_{11}^{[q]} &= x^{q+2} & \text{for } x < 0 \\ & x^{q+1} & \text{for } x \geq 0 \end{aligned}$$

$$\begin{aligned} a_{12}^{[q]} &= (x + \frac{1}{2})^{q+2} & \text{for } x < -\frac{1}{2} \\ & (x + \frac{1}{2})^{q+1} & \text{for } x \geq -\frac{1}{2} \end{aligned}$$

$$\begin{aligned} a_{21}^{[q]} &= (x - \frac{1}{2})^{q+1} & \text{for } x < \frac{1}{2} \\ & (x - \frac{1}{2})^{q+2} & \text{for } x \geq \frac{1}{2} \end{aligned}$$

$$\begin{aligned} a_{22}^{[q]} &= -x^{q+1} & \text{for } x < 0 \\ & -x^{q+2} & \text{for } x \geq 0 \end{aligned}$$

III) 
$$\begin{aligned} a_{11} &= 1 & \text{for } -1 < x \leq -\frac{1}{2} \\ & 0 & \text{for } -\frac{1}{2} < x \leq 0 \\ & 1 & \text{for } 0 < x \leq \frac{1}{2} \\ & 0 & \text{for } \frac{1}{2} < x < 1 \end{aligned}$$

$a_{12} = 0$	for $-1 < x \leq -\frac{1}{2}$
1	for $-\frac{1}{2} < x \leq 0$
0	for $0 < x \leq \frac{1}{4}$
1	for $\frac{1}{4} < x < 1$
$a_{21} = 0$	for $-1 < x < -\frac{3}{4}$
2	for $-\frac{3}{4} < x \leq 0$
0	for $0 < x \leq \frac{1}{4}$
2	for $\frac{1}{4} < x < 1$
$a_{22} = -1$	for $-1 < x \leq -\frac{1}{4}$
0	for $-\frac{1}{4} < x \leq 0$
-1	for $0 < x \leq \frac{1}{4}$
0	for $\frac{1}{4} < x < 1$ .

We compute  $\epsilon_i(p) = \|u_i - p^{\frac{1}{2}} u_i\|_{H^{\frac{1}{2}}(I)}$  and  $\eta_i(p) = \|u_i - u_{i,p}\|_{H^{\frac{1}{2}}(I)}$ ,  $i = 1, 2$  where  $u_{i,p}$  is the  $i$ th component of  $p^{\frac{1}{2}} A u$ . Obviously,  $\epsilon_i \leq \eta_i$ . The purpose of the computation is to see the effect of the matrix  $A$  on the error of the approximation, especially in dependence on the smoothness of the coefficients  $a_{ij}$ . Table 3.1 shows some of the results. We see that the influence of the smoothness on the performance is small, as expected. Moreover, we see that the asymptotic rate of convergence from Theorem 3.8 is already observed for small  $p$ .

TABLE 3.1  
The errors  $\epsilon_1$  and  $\eta_1$ .

p	$\epsilon_1$	$\eta_1$	$\epsilon_2$	$\eta_2$
CASE I				
4	2.2683-2	2.2718-2	2.1070-2	2.1150-2
8	8.2301-3	8.2586-3	7.8898-3	7.9168-3
16	2.7841-3	2.7910-3	2.7534-3	2.7601-3
32	9.1103-4	9.1242-4	9.0843-4	9.0977-4
CASE II, q = 3				
4	2.2683-2	2.3788-2	2.1070-2	2.4886-2
8	8.2301-3	8.6852-3	7.8898-3	8.9047-3
16	2.7841-3	2.9217-3	2.7534-3	3.1241-3
32	9.1098-4	9.4950-4	9.0843-4	9.9006-4
CASE II, q = 0				
4	2.2683-2	2.3117-2	2.1070-2	2.3632-2
8	8.2301-3	8.3735-3	7.8898-3	8.7462-3
16	2.7841-3	2.8326-3	2.7534-3	2.9975-3
32	9.1098-4	9.2162-4	9.0849-4	9.5976-4
CASE III				
4	2.2683-2	2.2763-2	2.1070-2	2.1459-2
8	8.2302-3	8.2438-3	7.8898-3	8.1540-3
16	2.7841-3	2.8078-2	2.7534-3	2.9632-3
32	9.1104-4	9.2687-4	9.0843-4	1.0191-3

### 3.3. THE PROJECTIONS $\hat{P}_p^1$ AND $\hat{P}_p^0$ AND THEIR PROPERTIES

In the previous section we have been interested in the projection  $\hat{P}_p^{1/2}$ . We can introduce the  $\hat{P}_p^1$  projection as follows. Let  $u \in H_0^1(I)$ , then

$$(3.43) \quad \hat{P}_p^1 u = \sum_{k=2}^p a_k \psi_k(x)$$

where  $\psi_k(x)$  were defined in Section 2 and the coefficients  $a_k$  in (3.43) are determined from the conditions

$$(3.44) \quad \int_{-1}^{+1} (\hat{P}_p^1 u)' \psi_j' dx = \int_{-1}^{+1} u' \psi_j' dx \\ = - \int_{-1}^{+1} u \psi_j'' dx, \quad j = 2, \dots, p$$

(where the span of  $\{\psi_j''\}$  is the set of all polynomials of degree  $p-2$ ).

(3.44) may be used to define  $\hat{P}_p^1 u$  for  $u \in H^0(I)$  as well.

If  $u \in H^1(I)$ , then we define analogously as before

$$(3.45) \quad \hat{P}_p^1 u = v + \hat{P}_p^1(u-v)$$

where

$$v = \frac{1}{2} (-x+1)u(-1) + \frac{1}{2} (x+1)u(1)$$

and hence  $\hat{P}_p^1$  is well defined for all  $u \in H^k(I)$ ,  $k > 1/2$ . In [5] we have proven

Theorem 3.9. Let  $u \in H^k(I)$ ,  $k > 1$ . Then

$$(3.46) \quad \|u - \hat{P}_p^1 u\|_{H_0^1(I)} \leq C p^{-(k-1/2)} \|u\|_{H^k(I)}.$$

We see that this theorem is analogous to Theorem 3.2 (in fact, it gives a

slightly better estimate). Nevertheless, Theorem 3.9 assumes that  $k > 1$ . We conjecture that for  $\frac{1}{2} < k < 1$

$$(3.47) \quad \sup_{u \in H_0^k(I)} \frac{1}{\|u\|_{H^k(I)}} \|u - \mathcal{P}_p^1 u\|_{H^{1/2}(I)} \geq C p^{-(k-1/2)} p^{\frac{(1-k)}{2}}.$$

In [2], [7] we have proven

Theorem 3.10

$$\sup_{u \in H_0^1(I)} \frac{1}{\|u\|_{H^0(I)}} \|u - \mathcal{P}_p^1 u\|_{H^0(I)} \geq C p^{1/2},$$

$$\|u - \mathcal{P}_p^1 u\|_{H^0(I)} \leq C p^{1/2} \|u\|_{H^0(I)}. \quad \square$$

From Theorem 3.10 we get

$$(3.48) \quad \|u - \mathcal{P}_p^1 u\|_{H_{00}^{1/2}(I)} \leq C p^{1/2} \|u\|_{H_{00}^{1/2}(I)}$$

but not necessarily (3.47). Nevertheless, numerical experimentation suggests that (3.47) holds for  $k = \frac{1}{2}$ .

To show it let for  $\alpha > 0$

$$(3.49) \quad u_\alpha(x) = \sum_{i=1}^{100} d_i \psi_i(x)$$

with

$$d_i = e^{-\alpha i}.$$

Select  $\alpha = \frac{2}{p}$  and compute

$$\chi_p(\alpha) = \|u_\alpha - \beta_p^1 u_\alpha\|_{H^{\frac{1}{2}}(I)}$$

and

$$\eta_p(\alpha) = \frac{1}{p^{\frac{1}{2}}} \chi_p(\alpha).$$

Table 3.2 shows the values of  $\eta_p(\alpha)$ ,  $\alpha = \frac{2}{p}$  which clearly indicate our conjecture

TABLE 3.2

The values of  $\eta_p(\alpha)$ ,  $\alpha = \frac{2}{p}$ .

p	$\eta_p$	p	$\eta_p$
1	.371	11	.645
2	.479	12	.647
3	.539	13	.647
4	.576	14	.648
5	.600	15	.648
6	.616	16	.648
7	.626	17	.668
8	.634	18	.648
9	.639	19	.648
10	.643	20	.647

So far we considered the projection  $\beta_p^1$ . Let us briefly also consider the projection  $\beta_p^0$ , which is given once more by (3.43) but with (3.44) replaced by

$$(3.50) \quad \int_{-1}^{+1} (\beta_p^0 u) \psi_j(x) dx = \int_{-1}^{+1} u \psi_j(x) dx.$$

Using the results from [2], [7] it is possible to prove

Theorem 3.11

$$\sup_{u \in H_0^1(I)} \frac{1}{\|u\|_{H_0^1(I)}} \|u - \beta_p^0 u\|_{H^1(I)} \geq C p^{\frac{1}{2}}$$

$$\|u - \overset{\circ}{P}_p^0 u\|_{H_0^1(I)} \leq C p^{1/2} \|u\|_{H_0^1(I)}.$$

This theorem suggests that (3.47) holds also for the projection  $\overset{\circ}{P}_p^0$ .

### 3.4. COMPARISON OF THE PROJECTIONS $\overset{\circ}{P}_p^{1/2}$ , $\overset{\circ}{P}_p^1$ and $\overset{\circ}{P}_p^0$

We are mainly interested in the approximation properties with respect to the norm  $\|\cdot\|_{H_{00}^{1/2}(I)}$ . The previous results show that seemingly the most robust projection is the projection  $\overset{\circ}{P}_p^{1/2}$  which leads to the error

$$(3.51) \quad \|u - \overset{\circ}{P}_p^{1/2} u\|_{H_{00}^{1/2}(I)} \leq C(k) p^{-(k-1/2)} \log^{1/2} p \|u\|_{H^k(I)}$$

for all  $1/2 < k$ . (We conjecture that the term  $\log^{1/2} p$  is not needed.)

The projection  $\overset{\circ}{P}_p^1$  leads to (3.51) also (in fact, without the term  $\log^{1/2} p$ ) but only for  $k > 1$ . For  $1/2 < k < 3/4$  the possibility exists that the projection  $\overset{\circ}{P}_p^1$  may not converge at all. In addition, the projection  $\overset{\circ}{P}_p^{1/2}$  can easily be generalized to  $\overset{\circ}{P}_p^{1/2, A}$ . This indicates that the projection  $\overset{\circ}{P}_p^{1/2}$  is preferable, nevertheless the projection  $\overset{\circ}{P}_p^1$  is almost as good. On the other hand, in context of the implementation in a finite element code using shape functions based on  $\psi_j(x)$  as in the code PROBE, the projection  $\overset{\circ}{P}_p^1$  is slightly preferable. The projection  $\overset{\circ}{P}_p^0$  seems to have no advantages.



#### 4. THE $p$ -VERSION OF THE FINITE ELEMENT METHOD

Let us consider here the convergence of the  $p$ -version of the finite element method when Dirichlet boundary conditions are prescribed as in (2.7), (2.8). We shall prove the following theorem

Theorem 4.1. Let the  $p$ -version of the finite element method be based on the projection  $P_p$  (see (2.8)) such that

$$(4.1) \quad \|u_p - g^{[i]}\|_{(H_{00}^{1/2}(\Gamma_i))^m} \leq C(k)f(p,i)p^{-(k-1)} \|g^{[i]}\|_{(H^{k-1/2}(\Gamma_i))^m}$$

and let the exact solution  $u_0 \in (H^k(\Omega))^m$ ,  $k > 1$ . Then

$$(4.2) \quad \|u_0 - u_p\|_{(H^1(\Omega))^m} \leq C(k)p^{-(k-1)} \max_i [f(p,i), \log^{1/2} p] p^{-(k-1)} \|u_0\|_{(H^k(\Omega))^m}.$$

Proof. For simplicity of notation, we let  $m = 1$ . Let  $Q = T$  or  $S$ . Let  $U_i(\xi, \eta)$  be defined on  $Q$  so that  $U_i(\xi, \eta) = u_0(F_i(\xi, \eta))$ . Because  $F_i$  is assumed to be smooth,  $U_i \in H^k(Q)$ . Hence as in [5] there exists  $U_{i,p} \in P_p^1(T)$ , respectively  $P_p^2(S)$ , such that

$$(4.3a) \quad U_i(A_j) = U_{i,p}(A_j)$$

where  $\{A_j\}$  are the vertices of  $Q$

$$(4.3b) \quad \|U_i - U_{i,p}\|_{H^1(Q)} \leq Cp^{-(k-1)} \|U_i\|_{H^k(Q)} \\ \leq Cp^{-(k-1)} \|u_0\|_{H^k(\Omega)}$$

$$(4.3c) \quad \|U_i - U_{i,p}\|_{C^0(\bar{Q})} \leq Cp^{-(k-1)} \|u_0\|_{H^k(\Omega)}.$$

On every  $\Gamma_{i,j} \notin \Gamma$ ,  $U_{i,p}(F_i^{-1}(x,y)) - U_{j,p}(F_j^{-1}(x,y)) = u_{i,p} - u_{j,p} = \phi_{i,j,p} \neq 0$  and (see Section 2.3 for notation)  $\phi_{i,j,p}(\xi) = \phi_{i,j,p}(F_i^*(\xi))$ ,  $\xi \in I$  is a polynomial of degree  $p$  in one variable with  $\phi_{i,j,p}(\pm 1) = 0$ . By the imbedding theorem

$$(4.4) \quad \|\phi_{i,j,p}\|_{H^{1/2}(I)} \leq C p^{-(k-1)} [\|u_i\|_{H^k(Q)} + \|u_j\|_{H^k(Q)}] \\ \leq C p^{-(k-1)} \|u_0\|_{H^k(\Omega)}.$$

Using Theorem 3.3, (4.3c) and (4.4) yield

$$(4.5) \quad \|\phi_{i,j,p}\|_{H_{0,0}^{1/2}(I)} \leq C p^{-(k-1)} \log^{1/2} p \|u_0\|_{H^k(\Omega)}.$$

Applying now Lemma 4.7 of [6] there is a  $v_{i,j} \in P_p^1(T)$ , respectively  $P_p^2(S)$ , such that

$$v_{i,j} = v_{i,j}(F_i^{-1}(x,y)) = \phi_{i,j,p} \text{ on } \Gamma_{i,j},$$

$$v_{i,j} = 0 \text{ on } \partial\Omega_i - \Gamma_{i,j}$$

and

$$\|v_{i,j}\|_{H^1(\Omega_i)} \leq \|\phi_{i,j,p}\|_{H_{0,0}^{1/2}(I)} \leq C p^{-(k-1)} \log^{1/2} p \|u_0\|_{H^k(\Omega)}.$$

Let now  $\Gamma_\ell \subset \partial\Omega = \Gamma$  and let  $\Gamma_\ell \subset \partial\Omega_r$ . Denote  $g_p^{[\ell]} \in P_p(\Gamma_\ell)$  such that  $\circ^A_p g_p^{[\ell]} = \circ^A_p g^{[\ell]}$ . Then on  $\Gamma_\ell$ ,

$$g_p - u_{r,p} = u_0 - u_{r,p} + g_p - g$$

and hence

$$\|g_p - u_{r,p}\|_{H_{0,0}^{1/2}(\Gamma_\ell)} \leq C p^{-(k-1)} [\log^{1/2} p + f(p, \ell)] \|u_0\|_{H^k(\Omega)}$$

and  $\varphi_{r,p}(\xi) = (g_p - u_{r,p})(F_r^*(\xi))$  satisfies  $\varphi_{r,p} \in P_p(I)$ ,  $\varphi_{r,p}(\pm 1) = 0$  as before. Hence, in the same way as before, by Lemma 4.7 of [6] we can construct  $v_{r,l}$  such that  $v_{r,l} = g_p - u_{r,p}$  on  $\Gamma_l$ ,  $v_{r,l} = 0$  on  $\partial\Omega_r - \Gamma_l$  and  $\|v_{r,l}\|_{H^1(\Omega_r)} \leq \|g_p - u_{r,p}\|_{H_{00}^{1/2}(\Gamma_l)}$ .

Defining  $\bar{u}_p \in P_p(\Omega) \cap H^1(\Omega)$  by

$$(4.6) \quad \bar{u}_p|_{\Omega_i} = u_i - \sum_j v_{i,j},$$

we get

$$(4.7) \quad \|u_0 - \bar{u}_p\|_{H^1(\Omega)} \leq C(k)p^{-(k-1)} \max_i [\log^{1/2} p + f(p,i)] \|u_0\|_{H^k(\Omega)}$$

and

$$\bar{u}_p = g_p \text{ on } \Gamma.$$

This leads immediately to (4.2). In fact, by (2.8)

$$B(u_p, v) = B(u_0, v), \quad \forall v \in P_p(\Omega) \cap H_0^1(\Omega)$$

and hence

$$B(u_p - \bar{u}_p, v) = B(u_0 - \bar{u}_p, v), \quad \forall v \in P_p(\Omega) \cap H_0^1(\Omega)$$

where  $\bar{u}_p$  is defined by (4.6). Because  $u_p - \bar{u}_p \in P_p(\Omega) \cap H_0^1(\Omega)$ , let  $v = u_p - \bar{u}_p$ . Using (2.6), we get immediately

$$\|u_p - \bar{u}_p\|_{H^1(\Omega)} \leq C \|u_0 - \bar{u}_p\|_{H^1(\Omega)}$$

and hence also

$$\begin{aligned} \|u_0 - u_p\|_{H^1(\Omega)} &\leq \|u_p - \bar{u}_p\|_{H^1(\Omega)} + \|u_0 - \bar{u}_p\|_{H^1(\Omega)} \\ &\leq C \|u_0 - \bar{u}_p\|_{H^1(\Omega)}. \end{aligned}$$

This gives (4.2). □

Theorem 4.1 leads to the following corollary

Corollary 4.2. Let  $u_0 \in H^k(\Omega)$ ,  $k > 1$ , be the solution of the problem (2.7),  $u_0|_{\Gamma_i} = g^{[i]}$ ,  $i = 1, \dots, n$ . Let the  $p$ -version of the finite element be used with  $P_p = P_p^{\frac{1}{2}}$  or  $P_p = P_p^{\frac{1}{2}}$ ,  $i$  where  $i$  are positive definite matrices with  $C^1$  coefficients on  $\Gamma_i$  (see (2.7), (2.8)). Then

$$\|u_p - u_0\|_{(H^1(\Omega))^m} \leq C p^{-(k-1)} \log^{\frac{1}{2}} p \|u_0\|_{(H^k(\Omega))^m}. \quad \square$$

Remark 4.1. A similar estimate follows from Theorem 4.1 for the projection  $P_p^1$ . In fact, for this case, the following result, proved in [5], is true.

Let  $u_0 \in H^k(\Omega)$ ,  $k > 3/2$  be the solution of the problem (2.7),  $u_0|_{\Gamma_i} = g^{[i]}$ ,  $i = 1, \dots, n$ . Let the  $p$ -version of the finite element be used with  $P_p = P_p^1$ . Then

$$\|u_p - u_0\|_{(H^1(\Omega))^m} \leq C p^{-(k-1)} \|u_0\|_{(H^k(\Omega))^m}. \quad \square$$

References

- [1] Andersson, B., Falk, U.: Finite Element Analysis of Three-Dimensional Structures Using Adaptive p-Extensions. The Aeronautical Research Institute of Sweden, FFA 5-H-800, April 1986. (Presented at Nato ASI, Lisbon, Portugal, June 1986.)
- [2] Arnold, D., Babuška, I and Osborn, J.: Finite Element Methods: Principles for their Selection. Comput. Meth. Appl. Math. Engrg. 45 (1984), 57-96.
- [3] Babuška, I.: The p and h-p Versions of the Finite Element Method. The State of the Art. Tech. Note BN-1156, Institute for Physical Science and Technology, University of Maryland, Sept. 1986. To appear in Proceedings of Workshop on Finite Element Methods, Springer-Verlag, 1987.
- [4] Babuška, I., Guo, B.: The h-p version of the finite element method with curved boundary and curved elements. Tech. Note BN-1057, Institute for Physical Science and Technology, University of Maryland, Nov. 1986.
- [5] Babuška, I., Suri, M.: The optimal convergence rate of the p-version of the finite element method. Siam J. Numer. Anal., 1987.
- [6] Babuška, I., Suri, M.: The h-p version of the finite element method with quasiuniform meshes. RAIRO, 1987.
- [7] Babuška, I. and Szabo, B. A.: Lecture Notes on Finite Element Analysis, in preparation.
- [8] Barnhart, M. A., Eiseman, J. R.: Analysis of a Stiffened Plate Detail Using p-Version and h-Version Finite Element Techniques. Paper presented at the First World Congress on Computational Mechanics, Sept. 22-26, 1986. The University of Texas at Austin.

- [9] Bergh, I., Lofstrom J.: Interpolation Spaces, Springer-Verlag, Berlin, Heidelberg, New York, 1976.
- [10] Gui, W., Babuška, I.: The h, p and h-p versions of the finite element method for 1-dimension. Part I: The error analysis of the p-version Num. Math. 49 (1986), 577-612. Part II: The analysis of the h and h-p versions, Num. Math. 49 (1986), 613-657. Part III: The adaptive h-p version, Numer. Math. 49 (1986), 659-683.
- [11] Guo, B., Babuška, I.: The h-p version of the finite element method, Part 1: The basic approximation results. Computational Mechanics 1 (1986), 21-41. Part 2: General results and applications, Computational Mechanics 1 (1986), 203-220.
- [12] Lions, J. L., Magenes, E.: Non-Homogeneous Boundary Value Problems and Applications. Springer-Verlag, Berlin, Heidelberg, New York, 1972.
- [13] Szabo, B. A.: PROBE, Theoretical Manual. Noetic Tech., St. Louis, 1985.
- [14] Szabo, B. A.: Implementation of a finite element software system with h and p-extension capabilities. Finite Elements in Analysis and Design 2 (1986), 177-194.
- [15] Szabo, B. A.: Mesh Design for the p-version of the finite element method, Comput. Meth. Appl. Math. Engrg. 55 (1986), 181-197.

END

9-87

Dtic