

AD-A181 994

Soviet Troop Control and the Power Distribution (U)
NAVAL POSTGRADUATE SCHOOL MONTEREY CA S R SNYDER
MAR 87

1/1

UNCLASSIFIED

F/G 25/5

NL

END
DATE
FILMED
-87

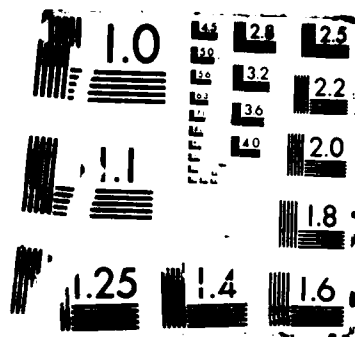

2

AD-A181 994

DTIC FILE COPY

NAVAL POSTGRADUATE SCHOOL

Monterey, California



DTIC
ELECTE
JUL 08 1987
S D D

THESIS

SOVIET TROOP CONTROL
AND THE
POWER DISTRIBUTION

by

Stanley K. Snyder

March 1987

Thesis Advisor:

John T. Malokas

Approved for public release; distribution is unlimited.

87 7 7 165

REPORT DOCUMENTATION PAGE

1a REPORT SECURITY CLASSIFICATION UNCLASSIFIED		1b RESTRICTIVE MARKINGS	
2a SECURITY CLASSIFICATION AUTHORITY		3 DISTRIBUTION/AVAILABILITY OF REPORT Approved for public release; distribution is unlimited	
2b DECLASSIFICATION/DOWNGRADING SCHEDULE		5 MONITORING ORGANIZATION REPORT NUMBER(S)	
4 PERFORMING ORGANIZATION REPORT NUMBER(S)		7a NAME OF MONITORING ORGANIZATION Naval Postgraduate School	
6a NAME OF PERFORMING ORGANIZATION Naval Postgraduate School	6b OFFICE SYMBOL (if applicable) 39	7b ADDRESS (City, State, and ZIP Code) Monterey, California 93943-5000	
6c ADDRESS (City, State, and ZIP Code) Monterey, California 93943-5000		9 PROCUREMENT INSTRUMENT IDENTIFICATION NUMBER	
8a NAME OF FUNDING/SPONSORING ORGANIZATION	8b OFFICE SYMBOL (if applicable)	10 SOURCE OF FUNDING NUMBERS	
8c ADDRESS (City, State, and ZIP Code)		PROGRAM ELEMENT NO	PROJECT NO
		TASK NO	WORK UNIT ACCESSION NO
11 TITLE (include Security Classification) SOVIET TROOP CONTROL AND THE POWER DISTRIBUTION			
12 PERSONAL AUTHOR(S) Snyder, Stanley K.			
13a TYPE OF REPORT Master's Thesis	13b TIME COVERED FROM TO	14 DATE OF REPORT (Year Month Day) March 1987	15 PAGE COUNT 39
16 SUPPLEMENTARY NOTATION			
17 COSAT CODES		18 SUBJECT TERMS (Continue on reverse if necessary and identify by block number)	
FIELD	GROUP	Troop Control, Command Control, Power Distribution, Reserves	
19 ABSTRACT (Continue on reverse if necessary and identify by block number)			
<p>This thesis explores the purpose of Soviet troop control and how it relates to their national policy and tactics for war. While their command decision making body is highly centralized, decision making is executed at the local level through a system of staff representatives to control the reserves.</p>			
20 DISTRIBUTION/AVAILABILITY OF ABSTRACT <input checked="" type="checkbox"/> UNCLASSIFIED UNLIMITED <input type="checkbox"/> SAME AS RPT <input type="checkbox"/> DTIC USERS		21 ABSTRACT SECURITY CLASSIFICATION UNCLASSIFIED	
22a NAME OF RESPONSIBLE INDIVIDUAL John T. Malokas		22b TELEPHONE (include Area Code) (408) 6462772	22c OFFICE SYMBOL 39

Approved for public release; distribution is unlimited.

Soviet Troop Control and the Power Distribution
by

Stanley K. Snyder
Lieutenant, United States Navy
B.S., Portland State University, 1979

Submitted in partial fulfillment of the
requirement for the degree of

MASTER OF SCIENCE IN SYSTEMS TECHNOLOGY
(Command, Control, and Communications)

from the

NAVAL POSTGRADUATE SCHOOL
March 1987

Author:

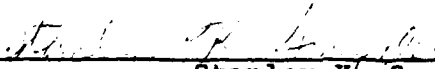

Stanley K. Snyder

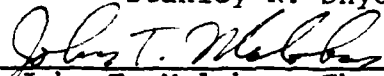
Approved by:

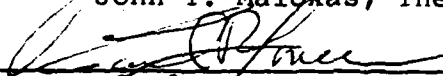
John T. Malokas, Thesis Advisor

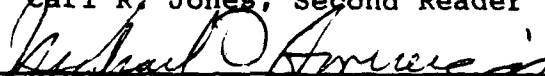
Carl R. Jones, Second Reader

Michael G. Sovereign, Chairman, Command,
Control and Communications Academic Group

David A. Schrad, Academic Dean

ABSTRACT

This thesis explores the purpose of Soviet troop control and how it relates to their national policy and tactics for war. While their command decision making body is highly centralized, decision making is executed at the local level through a system of staff representatives to control the reserves.

Accession For	
NTIS CRA&I	<input checked="" type="checkbox"/>
DTIC TAB	<input type="checkbox"/>
Unannounced	<input type="checkbox"/>
Justification	
By	
Distribution /	
Availability Codes	
Dist	Avail and/or Special
A-1	



TABLE OF CONTENTS

LIST OF FIGURES.....	5
I. INITIAL CONCEPTS.....	6
A. INTRODUCTION.....	6
B. SCOPE OF THESIS.....	8
C. HYPOTHESIS.....	9
D. CONCLUSION.....	11
II. SOVIET TROOP CONTROL.....	13
A. SOVIET PERSPECTIVE ON TROOP CONTROL.....	13
B. DEFINITION OF TROOP CONTROL.....	15
C. PRINCIPLES OF TROOP CONTROL.....	17
D. CONCLUSION.....	19
III. SOVIET TACTICS AND DOCTRINE.....	20
A. THE OFFENSIVE.....	20
B. THE BREAKTHROUGH.....	21
C. IMPLICATIONS FOR COMMAND AND CONTROL.....	23
D. CONCLUSION.....	24
IV. SOVIET TROOP CONTROL STRUCTURE.....	25
A. INTRODUCTION.....	25
B. TERRITORIAL STRUCTURE OF COMMAND.....	25
C. SOVIET COMMAND ORGANIZATION.....	27
D. CONTROL OF THE RESERVES.....	31
E. CONCLUSION.....	34
APPENDIX: LIST OF ACRONYMS.....	35
LIST OF REFERENCES.....	36
INITIAL DISTRIBUTION.....	38

LIST OF FIGURES

4.1 Composition of Soviet Council of Defense and SHC....29
4.2 Soviet System of Command and Control.....32

I. INITIAL CONCEPTS

A. INTRODUCTION

The focus of this thesis will be on the nature of Soviet command and control and the implications of that control for U.S. military planners. Soviet military literature discusses the "revolution in military affairs" that has taken place since 1950. In that literature they have described the revolution as having three distinct phases: [Ref. 1, p. 114; Ref. 2, p. v; Ref. 3, p. 13]

1. weapons of mass destruction (nuclear weapons)
2. long range means of delivery (ICBM's)
3. command and control.

These phases are a result of technological advances in the means of waging war. The first phase eludes to nuclear weapons. The second phase deals with ICBM's, the method of long range delivery. The third phase deals with changes in command and control. The importance of considering these phases is to study and understand the changes in military operations and warfare that have taken place. In the words of Soviet Marshal Sokolovskii:

The revolution in military affairs is the reason behind changes in doctrine and strategy, which will result shortly in corresponding changes in the operational art and tactics. [Ref. 3, p. 13]

The politburo and military establishment in the Soviet Union have used the revolution in military affairs to draw attention to changes in warfare that have taken place. [Ref. 4, p. 57]

Command and control, the third phase of the revolution, is now taking place. The first two phases, weapons of mass destruction and long range means of delivery, have already taken place, and their implications are known and established. The Soviets are still trying to adjust to changes caused by the first two, as is the rest of the world. Changes taking place in command and control are a result of the need to adjust to changes in warfare.

The effect nuclear weapons have had on world political and military affairs has been discussed for years. Now there is a need to study command and control, the third phase of the revolution in military affairs in the context of weapons of mass destruction, to gain an understanding of their troop control system and how it might be used against U.S. forces.

An examination must be made of the effects nuclear weapons and ICBM's have had on command and control, and in particular, Soviet command and control structure. These weapons have created the need for the highest level authority to be in control of the use of certain types of weapons, namely weapons with nuclear warheads, regardless of what form they may be in.

B. SCOPE OF THESIS

The theme of this thesis will be the study of the Soviet command and control structure and organization. The two phases leading to the present revolution in military affairs have been mentioned and will be examined as to the effect they have had on the structure of Soviet command and control.

In the author's opinion history must be considered in studying the current Soviet command and control organization. The Soviets have relied on history to structure their command and control system. [Ref. 5, p. 5] The writings of Lenin and the study of World War II have been important sources for Soviet command and control.

With the increased range and kill radius of nuclear and conventional weapons the time for tactical decision making and planning of the offensive has been reduced. This has had an impact on the premise of Soviet combat action: the offensive and the means of conducting the offensive. It will be shown that these tactical considerations are the driving reason behind the Soviet command and control system. [Ref. 3, p. 38] The fast pace of modern warfare has led to an increase in the need for flexibility of command decision making in combat.

Carrying out the offensive requires the coordination of various supporting arms and forces. Flexibility in the execution of troop control is needed to properly conduct the

offensive. The Soviets have designed flexibility into their command and control structure to control combat action by using a system of high level staff representatives at the local level of combat action.

C. HYPOTHESIS

The hypothesis of this thesis is that the Soviet command and control structure is organized to take advantage of the "power distribution", the power distribution being the control of the reserves and supporting forces such as artillery and tanks to conduct offensive action. By effectively controlling the reserves, and committing them to the proper breakthrough point, they will be more successful in combat.

Control of the reserves is critical because the outcome of individual combat action on a wide front is of a stochastic nature. Hence where the breakthrough will occur on a battlefield cannot be predicted. [Ref. 6, p. 56] When a breakthrough does occur, it is important to commit the reserves to the breakthrough point to open the enemy's defense on a wide scale, an opening the enemy may not be able to close with all of the reserves. This is what is meant by the power distribution. As Orr stated in his book, "Combat Operations C3I: Fundamentals and Interactions", the power distribution is essentially a measure of potential of the commander's reserve force. [Ref. 6, p. 57]

Although the Soviets do not use the term "power distribution" in their military writings, they talk constantly about the reserves and the breakthrough point, and forging and opening in the enemy's lines that the enemy will not be able to close. [Ref. 7, p.3]

The hypothesis of this thesis is that the Soviet command and control system is organized to take advantage of the "power distribution" and to control it. While their command and control structure is highly centralized, decision making is executed at the local level for control of the reserves. [Ref. 8, p. 1816] One possible reason for being structured in a centralized manner was mentioned above: to control the power distribution by executing decision making at the local level. However, there are other reasons not fully explained or discussed in Soviet military writings. Some reasons that have been recognized are the spatial nature of the battlefield, tactical nuclear weapons, the decreased time factor for decision making, and the information that must be considered. [Ref. 3, p.4]

Further possible reasons for a centralized structure include the following:

- a) The breakthrough may not occur in one area, or in the area of a single decision maker. If it occurs in an area of responsibility of two commanders, commitment of the reserves, coordinating action, and supporting fire would require additional planning time and may delay or miss the exploitation of the opportunity to breakthrough.
- b) If the breakthrough occurs in one area, it is possible that the size of the breach may be too large, or the

troops needed to fully exploit it may not be available. In short, a single commander may be in a situation where he does not have the requisite reserves to fully exploit the breakthrough. This would require the commander to obtain reserves from other commanders on the same level as himself. While this is possible, the other commander would be more likely to hold his reserves in his sector, under his command, in order to exploit the breakthrough in his own sector when it occurred. A senior commander at the local level would have the authority to coordinate forces from other areas to exploit the breakthrough. [Ref. 9, p. 287]

- c) The commander in whose area the breakthrough occurs may not recognize the breakthrough when it happens. Commanders can easily become bogged down in matters not directly related to battle: day-to-day operations of the command, troop morale, logistics, and other related matters. These details are important to running the command and to success in battle, but they can tax the commander's time and decrease the time that is spent on planning for the offensive. The time available for the evaluation of information about the battle is thus decreased. Probably the most striking reason for the commander not recognizing the breakthrough point is lack of understanding, or knowledge about the total war effort. The commander is aware of the situation, requirements, and objectives of this area and possible adjacent areas. How the total war effort is tied together may not be obvious to him. What may not seem as a breakthrough point to exploit to a lower level commander, may appear as an obvious point of attack to a higher level commander from the General Staff, who has a global view of the war.

D. CONCLUSION

The hypothesis of this thesis is that the Soviet command and control system is organized to control the power distribution. The three points mentioned above--location of the breakthrough, size of the reserves needed to exploit the breakthrough, and recognition of the breakthrough point--relate to the hypothesis in that a highly centralized

organization is best suited for coping with these three uncertainties of war. Chapter II will explore Soviet command and control in depth and define command and control from a Soviet perspective and in the context of their culture. Chapter III will discuss Soviet tactics, doctrine, and their requirements for the offensive. Chapter IV will examine the Soviet troop control structure and how it is organized. Throughout, the critical point of Soviet troop control is that it is highly centralized, but decision making is executed at the local level to control the power distribution.

II. SOVIET TROOP CONTROL

A. SOVIET PERCEPTIVE ON TROOP CONTROL

The Russian culture must be understood to gain an understanding of the Soviet command and control structure. To do a study of Soviet troop control it must first be approached from the Russian point of view, because to do otherwise would lead to the wrong interpretation. [Ref. 3, p.10] The Soviets know that there is a difference in eastern and western thought. As former Soviet Army Colonel Alge Penkovskiz, who turned over a large volume of Soviet military writings to the British in 1960, wrote:

One thing must be clearly understood. If someone were to hand to an American General, an English General, and a Soviet General the same set of objective facts and scientific data, with instructions that these facts and data must be accepted as unimpeachable, and an analysis made and conclusions drawn on the basis of them, it is possible that the American and the Englishman would reach similar conclusions, I don't know. But the Soviet General would arrive at conclusions which would be radically different from the other two. This is because, first of all, he begins from a different set of basic premises and preconceived ideas, namely, the Marxian concepts of the structure of society and the course of history. Second, the logical process in his mind is totally unlike that of his western counterparts, because he uses Marxist dialects, whereas they will use some form of deductive reasoning. Third, a different set of moral laws governs and restricts the behavior of the Soviet. Fourth, the Soviet General's aim will be radically different from those of the American and the Englishman. [Ref. 10, p.13]

An understanding of Marxist-Leninist philosophy is needed to appreciate the Soviet view. For the Marxist-Leninist philosophy explains the world for the Soviets, and

it is the view of the world that is officially adopted by the Soviet Union. [Ref. 10, p. 15] Prof. James G. Taylor offers an explanation of the Marxist-Leninist philosophy.

Marxist-Leninist philosophy holds matter (i.e., the material world) as primary and consciousness as secondary. Matter exists independently of human consciousness and is governed by laws. These laws are in principle cognizable by man, we can recognize them with the help of practical action. Thus, the Soviets believe in the dialectical unit of theory and practice, theory guides practice and practice validates theory.

Moreover, the laws of materialistic dialectics are considered by Marxist-Leninist philosophy to be the most general laws describing the evolution of the material world. Not only do they apply to the material world, but through the process of reflection by the human mind they apply to human thought (dialectical logic) and human knowledge. Hence, the Soviets believe that the laws of materialist dialectics also apply to the command decision making process. [Ref. 10, p. 16]

It is not the purpose of this thesis to explain all of the principles behind dialectic materialism, but the Marxist Leninist philosophy is supported by the dialectic materialism, and it is the Marxist-Leninist view that gives the Soviets their understanding of the world.

The military potential of a country can be measured in the size of its army, navy, and economic base. The Soviets feel that their troop control structure is part of their nation's military potential. During war the potential of a command and control system can be measured by success or failure in combat. In peacetime the Soviets measure the potential of their troop control system by the readiness of troops to conduct wartime operations. [Ref. 10, p. 4] Higher combat potential of a troop control system comes from

the ability to make a quicker and more accurate decision about a combat situation. A superior command and control system may serve as a force multiplier, compensating for weakness in other areas. [Ref. 11, p. 4]

B. DEFINITION OF TROOP CONTROL

The Soviets have defined troop control in their Military Encyclopedic Dictionary as follows:

Troop control is the activity of commanders of operational level units (tactical-level units, or any other type of troop unit), staffs, political organs, departments, and other control organs on maintaining constant combat readiness of their troops, preparing operations and tactical actions, and directing troops for the carrying out of assigned missions. It includes:

- (1) continuous receipt, collection, study, representation, and analysis of data concerning the situation
- (2) making a decision about the operation (tactical action)
- (3) disseminating missions to subordinate troops
- (4) planning the operation (tactical action)
- (5) organizing and maintaining mutual support
- (6) preparing troops and staffs for combat operations and directing them directly
- (7) organizing and carrying out measures on party-political work and all types of support
- (8) creating a system of troop control
- (9) organizing the monitoring and giving assistance to commanders of subordinate operational level units, staffs, and troops.

Troop control is carried out personally by the commander of the operational-level (tactical-level) unit through his staff, and also through his deputies and the

chiefs of branches of troops, special troops, and services in accordance with the orders, directives, and instructions of superiors. The basis of troop control is the decision of the commander of the operational-level unit (tactical-level unit, or any other type of troop unit). The basic principles of troop control are:

- (1) one man command
- (2) centralization of control is all component elements, with retention by subordinates of the possibility to show initiative in determining the means of carrying out the mission assigned to them
- (3) firmness and persistence in carrying out the decisions that have been made by superiors
- (4) timely reaction to changes in the situation
- (5) continuity and security
- (6) personal responsibility of the commander for the decision that is made, use of subordinate troops, and the results of carrying out the mission assigned to them

For putting troop control into practice one creates a control system that includes:

- (1) organs of control
- (2) points of control
- (3) a communication system
- (4) automated systems of troop control, and
- (5) other special systems. [Ref. 12, p. 766]

What the Soviets require of their troop control is that it be flexible, organized to carry out the combat mission, and that the commander take an active role in the implementation of the combat plan and monitoring of actions by subordinates.

C. PRINCIPLES OF SOVIET TROOP CONTROL

To carry out troop control as defined above, the Soviets have stated principles for their troop control system and the commander to meet. These include centralization, flexibility, firmness, checking of the execution, and continuous troop control. Each will now be discussed because they show how the Soviets put their definition and requirements for troop control into practice.

By taking advantage of advances in technology, the Soviets have been able to centralize more of their command structure on a broader scale. Colonel General G. Vorontsov described it in this way:

The principle of centralization, the essence of which is that lower echelon control bodies strictly fulfill the orders, directives, and instructions of the higher bodies and report on their activity and on the actions and efficiency of troops subordinated to them. At the same time the centralization practiced in the Soviet armed forces provides the possibility for subordinate echelons of command to display the necessary initiative and independence in action for the better fulfillment of the assigned mission. [Ref. 13, p. 39]

For the Soviets, centralization of their troop control allows for flexibility and swiftness in combat. Flexible troop control to the Soviets means quick reaction to changes in the combat situation. Flexibility includes the timely specification or changing of an order already given, and precise assignment of new combat missions to subordinate commands. [Ref. 14, p.23] The purpose of flexibility to the Soviet is for the right troops to be in the right place at

the right time. Flexibility is a Soviet requirement for strategic conventional war.

Firmness of troop control implies a persistent implementation of the decision made by the commander. The Soviets see the need for firmness in that actions on the battlefield do not always proceed as planned. But with the firmness of troop control by the commander, a method and way for the implementation of a backup plan will be found. [Ref. 14, p.23] Firmness is maintained by a continuous checking of the execution and actions of subordinates. [Ref. 13, p. 39]

Checking the execution of orders given to subordinates is done by receiving continuous reports on the combat situation. The commander, as the controlling organ, cannot make adjustments to or maintain control of combat without feedback on the progress of failure of assigned missions. [Ref. 15, p. 14] If feedback fails, the commander will no longer be in control.

Continuous troop control is the commander's constant and effective influence on the progress of subordinates completing assigned combat missions. [Ref. 14, p. 24] To be able to influence the outcome of battle, the commander must have full knowledge of the tactical situation as it is developing. To accomplish continuous troop control the commander must maintain reliable communications with subordinate commands.

The Soviet commander is solely responsible for implementing the principles of troop control and for the actions of those subordinate to him in implementing the principles of troop control.

D. CONCLUSION

The principles of troop control, centralization, flexibility, firmness, checking of the execution, and continuous troop control are all tied to one another by the need for control of troops under conditions of uncertainty. Together, they complement each other and give the Soviets the necessary leadership which they believe will ensure victory over their enemies in combat. [Ref. 14, p.24]

This chapter has discussed Soviet troop control from their cultural perspective and has defined Soviet requirements for a troop control system and the commander to carry out. Chapter III will examine Soviet tactics and the offensive, the premise of their combat doctrine.

III. SOVIET TACTICS AND DOCTRINE

A. THE OFFENSIVE

Soviet military theorist have identified four basic types of tactical combat action. They are:

- 1) offensive
- 2) meeting engagements
- 3) defensive
- 4) withdrawal. [Ref. 5, p. vii]

The study of world military history by the Soviets has proved to them that of the four types of combat action only the offensive will yield the destruction of the enemy's means of conducting war. Hence, success in combat can only come from employment of the offensive. In the winter of 1941/42 with Moscow under siege the Soviets launched a counteroffensive to turn back the Germans. [Ref. 7, p. 8] By choosing the offensive the Soviets are putting the enemy on the defensive and making the enemy fight a tactical combat action from which victory cannot be attained.

The advantage of the offensive position is that the aggressor controls the following points of war:

- 1) initiative
- 2) axes selection
- 3) direction

- 4) time of attack
- 5) method of attack.

While troops in the defensive position must guard many areas along a front, the attacker can choose the area to launch his strike against. The aggressor can select the axes of attack that have the highest chance of being successful. [Ref. 7, p. 2]

The offensive, however, is only possible after the breakthrough has been obtained, the breakthrough leads to the offensive. If the breakthrough is not accomplished the entire offensive would come to a halt. [Ref. 5, p.13]

B. THE BREAKTHROUGH

The breakthrough point is that point along a front where defensive forces are destroyed to a degree that they are no longer able to hold their position, and hence must withdraw and reestablish their line of defense. The breakthrough point is also that sector along the front of offensive action where the aggressor forces the attack and masses troops for advance into the enemy's territory.

Obtaining a breakthrough in the enemy's defense is necessary to lead to offensive action, and to maintain the offensive attack. As A.A. Sidoreko, a well-known Soviet author on military tactics wrote:

If for some reason the breakthrough could not be accomplished, then the entire offensive operation died down regardless of how well the subsequent stages for its development were worked out and thought through. [Ref. 5, p. 13]

The point of breakthrough is a result of the stochastic nature of combat. Once it has occurred there must be a proper selection of the axis of advance to exploit the breakthrough and maintain the offensive.

The selection of the main axes of advance involves many factors. During World War II the most vulnerable point in the enemy's main force was generally the point of attack. In most cases the Russians choose the main axes of advance such that it will lead to the rapid defeat of the enemy and decrease the stability of the enemy's troops along the front. [Ref. 7, p. 155]

In selecting the axes of advance, a large consideration to the Soviets is the mission to be accomplished. Other factors in the selection of the axes are geography, time of the attack, and the composition of enemy forces. [Ref. 7, p. 154]

Lenin stated that to be successful in combat it is essential to have superiority of forces over the enemy at the decisive point and at the decisive time. [Ref. 7, p. 154] Massing of forces at the breakthrough point is essential to the conduct of the offensive. The massing of forces is the control of the power distribution. The increased mobility of Soviet troops aids them in the massing of forces, but the proper massing of forces will always be a coordination problem and hence a troop control problem.

For the breakthrough to be successful there must be reserves to commit to the breakthrough point at the correct time. Victory can only come from offensive action, offensive action is only possible with the breakthrough along the front; and the breakthrough can only occur with coordinated reserves to obtain superiority of forces over the enemy.

C. IMPLICATIONS FOR COMMAND AND CONTROL

The use of more technical and various types of weapons in combat, as well as the use of specialized troops has complicated the coordination effort of modern combat. With the changes in warfare has come the need for changes in troop control. Centralization of troop control is used by the Soviets, especially in the planning for the offensive. [Ref. 5, p. 38] With centralized control the Soviets are able to control the reserves more effectively in battle.

The Soviets have outlined the requirements for a successful offensive and breakthrough:

- 1) preparation
- 2) planning
- 3) intelligence on the enemy
- 4) skillful employment of troops
- 5) firm, flexible, and continuous troop control. [Ref. 7, p.74]

To the Soviets, the out come of battle is not only determined by control of the reserves and massing of troops,

but also by the quality of combat preparation, effective troop control, and coordination among combat arms. [Ref. 7, p. 159]

What the Soviets have done is to tie their tactics for success in combat to their troop control structure. They require flexibility in their troops for action on a front, and they have designed their troop control structure to give them that needed flexibility in combat. The Soviets believe that the organization and execution of the offensive cannot be separated from the commands and staffs that support and direct troop control functions. [Ref. 5, p. 3] The Soviets have made their command and control structure a bona fide force multiplier.

D. CONCLUSION

As discussed the Soviet troop control system is highly centralized for control of the reserves at the breakthrough point. The flexibility in their tactics comes from having high-level representatives at the local level of decision making. Chapter IV will examine their troop control structure and how it is organized to give them flexibility in the massing of forces, control of the reserves and for carrying out battle plans.

IV. SOVIET TROOP CONTROL STRUCTURE

A. INTRODUCTION

This chapter will examine the command and control structure of the Soviet military command decision-making bodies. To prove the hypothesis, that the Soviet troop control system is designed to control the power distribution, the composition of the Soviet Defense Council, Supreme High Command (SHC), and the process of staff representatives at the front, army, and division level will be examined. World War II examples will be used to show how the Soviets achieve flexibility and control of the power distribution with a centralized command structure.

Section B will define the Soviet territorial structure of command. Section C will examine the Soviet command organization. Section D will show how their tactics are related to their command system for control of the reserves.

B. TERRITORIAL STRUCTURE OF COMMAND

The Soviets believe a war could breakout at any time and at any place in the world and train to fight this kind of war. For this reason they have divided up the world into "military-geographical" zones. These zones are called TVD's (teatr voyennykh deystviy), which translates into Theater of Strategic Military Action (TSMA). A TSMA includes the following:

Part of the continental territory with its coastal waters, inland seas and airspace (continental TSMA), or the water areas of one ocean, including islands, adjoining seas and coastal land belts (oceanic TSMA) within the boundaries of which strategic groupings of armed forces may be deployed and military operations carried out. [Ref. 8, p. 1813]

This is not to imply that there are always troops and naval forces stationed in a TSMA. During World War II there was an instance where there were three CINC (Commander in Chief) operating in one TSMA. [Ref. 8, p. 1816] This point is important in understanding that a CINC is different from a theater. While a CINC would be in command of forces, a territory holds different meaning to the Soviets. The CINC has a military command not a territory command, which means his forces can conduct operations across a theater. This can result in more than one commander in the same geographic area. This point was mentioned in Chapter I in regard to the breakthrough point occurring in the area of more than one commander.

Soviets coordinate most of their operational planning for the theater level of conflict. Within a geographic sector they plan combat on four levels:

- 1) strategic military action in a theater
- 2) strategic direction
- 3) operational direction
- 4) zone of advance. [Ref. 9, p. 282]

This planning is a continuous process. It is done in peacetime and continues throughout the conflict. During

peacetime the planning would include construction of roads, airfields, supply stations, and radar sites to name a few. As tensions increase, troops would be forward deployed to hot spots. With troops on station they would be able to carry out operational plans at the outbreak of fighting, thus gaining the initiative. [Ref. 16, p. 283]

Each TSMA contains at least one strategic direction (a strategic direction being a sector or axes of advance), which would lead the Soviet forces to the economic and political control centers of their enemy. The sector includes land, air, and any waterways that may enhance the advance. The strategic direction would be undertaken by combined forces on a front.

Contained within each strategic direction is one or more operational directions. An operational direction may be defined as the land, air space, and waterways where operational strategic formations conduct battle. [Ref. 9, p. 283] The zone of advance would include the breakthrough point discussed in Chapter III.

C. SOVIET COMMAND ORGANIZATION

To fully understand Soviet troop control it is necessary to be aware of the various command decision-making bodies and their composition. At the highest level is the council of defense which is comprised of the following members:

- 1) General Secretary CPSU
- 2) Minister of Defense

- 3) Chief of the General Staff
- 4) Chairman KGB
- 5) Chairman council of Ministers of the USSR
- 6) Other party and state officials as required. [Ref. 9, p. 280]

The Council of Defense has complete and absolute control over the military and economic direction of the USSR. The General Secretary heads the Council of Defense as well as the SHC, or Stavka as the Soviets refer to it. The Council of Defense plans for the mobilization of the country's industry, manpower, and transportation. Figure 4.1 [Ref. 9] shows the composition of the Council of Defense and the SHC. The council of defense is there to unify military and civilian leaders to ensure the proper political direction for the military.

The SHC shown in Figure 4.1 is subordinate to the council of defense. In peacetime the SHC is referred to as the Main Military Council and is responsible for the strategic direction and leadership of all Soviet armed forces.

The General Staff below the SHC is referred to as the working organ of the SHC. [Ref. 9, p. 286] The Soviets have never revealed the organization or members of their General Staff, although it is the largest of the main staffs. What is known about the General Staff is that it is comprised of officers from all services, however they do not represent service interests. [Ref. 17, p. 55]

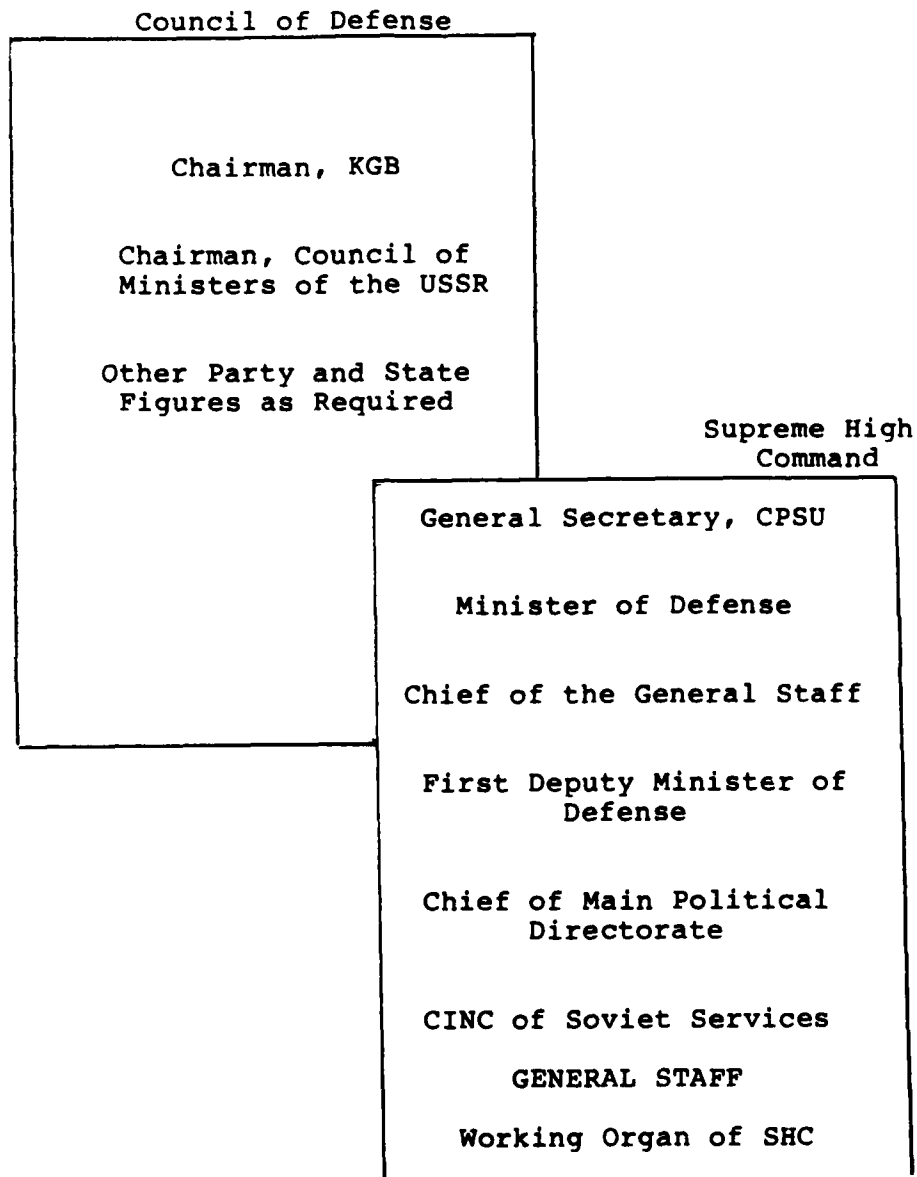

Figure 4.1 Composition of Soviet Council of Defense and SHC.

The function of the General Staff is to analyze military and political situations as they develop, and to formulate a unified strategy which applies to all services and the national interest. They insure that coordinated action will occur from other various service staffs and from commanders. [Ref. 17, p. 55] The staff has a military as well as a civilian responsibility and is given the power to develop military doctrine and policy of the CPSU.

For flexibility the SHC can create a high command (GK) under their control for special and unique military situations. GK translates to "organ of strategic command and control". The GK is a command which coordinates forces in wartime. The GK can control a large amount of area or a narrow sector. Regardless of the amount of land covered the GK is a military command and not a territory command. The GK is a staff and has no troops or supplies attache to it. [Ref. 8, p. 1818]

The High Command of Forces (HCOF) in a TSMA is the level where detailed planning for front operations would be carried out.

The various command decision making bodies have been examined. The next section will show how the Soviet high level commands are organized to conduct combat operations and control the reserves.

D. CONTROL OF THE RESERVES

The Soviets feel that the fast pace of the next war will be such that they will not have the opportunity to reorganize their command and control system as they did in World War II. Believing this, the Soviets use the same command and control structure for fighting a nuclear and conventional war. [Ref. 9, p. 286]

As seen in Chapter III on tactics, Soviets feel the critical element of battle to be the concentration of forces at the breakthrough point at the proper time.

In the opinion of the Soviet leadership the next war will move much more rapidly than previous ones, loss of communications at all levels will be common, and crises will arise constantly. The importance of flexibility in strategic command and control will grow, as will be the necessity of being able to untie at a decisive moment various types of forces under the command of a commander with full power and knowledge of local circumstances. It is impossible to predict where or when a decisive moment will arise. Therefore it is considered better to keep a top marshal in Moscow, free of minor concerns, giving him the opportunity to follow events on a world wide scale and to be abreast of all Soviet preparations. [Ref. 8, p 1818]

In view of what was presented earlier on the control of the reserves, this is nothing more than Orr's control of the power distribution, discussed in Chapter I. As has been shown, tactics drive their command and control structure.

To obtain the needed flexibility in combat the Soviets use a system of staff representatives for control in battle. Figure 4.2 shows the system of staff participation in combat. Notice that the SHC has three methods of exercising control of forces:

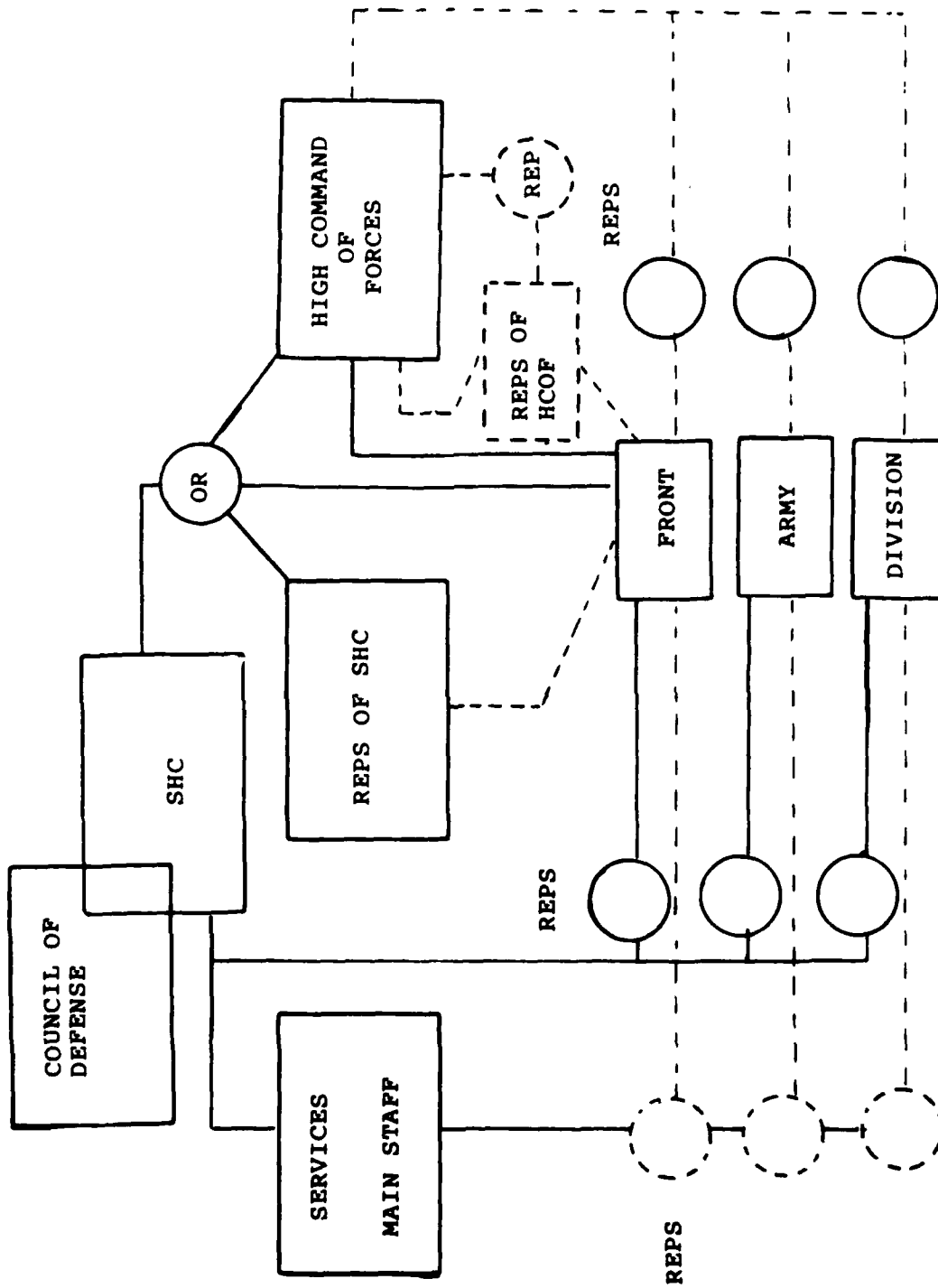

Figure 4.2 Soviet System of Command and Control

- 1) the SHC can exercise direct control over action on a front
- 2) a SHC representative can temporarily take over command of a front
- 3) an intermediate organ of strategic command and control could be created (GK). [Ref. 8, p. 1816]

For example, in World War II the Soviets used staff representatives to control combat:

At decisive moments of the war Stalin would send a top ranking representative to the decisive place with unlimited power. Thus the local Soviet commander had a deputy of the Soviet Supreme Command at his side during a crisis. In this way the experience and detailed knowledge of the local commander was reinforced by the wider overall view and full powers of the Supreme command. [Ref. 8, p. 1118]

In combat, when decisions are time critical, a local commander would not have to call Moscow for advice or instructions, he would have a staff representative from the SHC on the scene. This method of staff representatives is what is meant when stated that the Soviet command and control system is highly centralized, with decision making executed at the local level for flexibility and control of the reserves.

The staffs not only aid local commanders in making military decisions, they also are present to insure that the plans of the SHC are being carried out. The Soviets feel that this type of centralized control increases the flexibility of combat forces to respond in a timely manner to sudden developments on the battlefield.

E. CONCLUSION

The hypothesis of this thesis is that the Soviets are organized for control of the power distribution. It was stated that the possible reasons for this organization was:

- 1) Will the breakthrough or decisive point be in an area under the command of a single commander?
- 2) Does the commander have the reserves to exploit the breakthrough?
- 3) Does the commander recognize the breakthrough?

These three points mentioned above have been shown in this thesis to be major concerns of Soviet military planners. The research has shown that their tactics and troop control system is designed to compensate for the stochastic nature of combat and the control of the reserves.

The implications for U.S. military planners lay in the area of command and control counter measures. Using the work done in this thesis as a base, additional study can be conducted to determine how to affect their troop control system. The principles of command and control counter measures call to induce uncertainty, increase the time for decision making, and delay the employment of reserves at the breakthrough point.

For the U.S. to disrupt control of those forces or attacking of those forces before they could be employed would be a strategy to be used.

APPENDIX: LIST OF ACRONYMS

CINC COMMANDER IN CHIEF
CPSU COMMUNIST PARTY OF THE SOVIET UNION
C3I COMMAND CONTROL COMMUNICATION AND INTELLIGENCE
GK HIGH COMMAND
HCOF HIGH COMMAND OF FORCES
ICMB'S INTER CONTINENTAL BALLISTIC MISSILES
KGB SOVIET INTELLIGENCE AGENCY
SHC SUPREME HIGH COMMAND
TSMA THEATER OF STRATEGIC MILITARY ACTION
TVD SAME AS TSMA (teatr voyennykh deystviy)
USSR UNION OF THE SOCIALIST SOVIET REPUBLICS

LIST OF REFERENCES

1. Intelligence Highlights, "Survivability of the Soviets C³ System." Signal, December 1984.
2. Druzhinin, V.V. and Kontrov, D.S., Decisions, Concepts, Algorithm. Translated by USAF. Moscow 1972.
3. Hemsly, John, Soviet Troop Control. Brassey's Pub. Limited, 1982.
4. Scott, William F., "Soviet Military Doctrine and Strategy: Realities and Misunderstandings." Strategic Review, AF Magazine, 3 November 1975.
5. Sidorenki, A.A., The Offensive. Translated by USAF. Moscow, 1970.
6. Orr, George E., Combat Operations C³I: Fundamentals and Interactions. Maxwell Air Force Base, Alabama: Air University Press, July 1983.
7. Radziyevskiy, A.I., Wartime Operations in 1944-1945: The Breakthrough. Moscow, 1979.
8. Suvorov, Viktor, "Strategic Command and Control: The Soviet Approach." International Defense Review, December 1984.
9. Hines, John G. and Petersen, Phillip A., "Changing the Soviet System of Control." International Defense Review, March 1986.
10. Taylor, James G., Initial Concepts of Soviet C². Naval Postgraduate School,
11. Van Credvld, Martin, Command In War. Cambridge: Harvard University Press, 1985.
12. Soviet Military Encyclopedic Dictionary. Moscow, 1983.
13. Vorontsov, G., "The Art of Troop Control." Soviet Military Review, No. 7, 1975.
14. Bakanov, R., "Precise Troop Control-Success in Battle." Soviet Military Review, No.10, 1975.
15. Bokarev, V. "Principles of Scientific Troop Control." Soviet Military Review, No. 9, 1975.
16. Erickson, John, "Soviet Cybermen: Men and Machines in the System." Signal, December 1984.

17. Scott, H.F., "The Soviet High Command." AF Magazine,
No. 3, 1977.

INITIAL DISTRIBUTION LIST

	No. Copies
1. Defense Technical Information Center Cameron Station Alexandria, Virginia 22304-6145	2
2. Library, Code 0142 Naval Postgraduate School Monterey, California 93943-5002	2
3. Superintendent, Code 74 ATTN: Prof. M.G. Sovereign Naval Postgraduate School Monterey, California 93943-5000	1
4. Superintendent, Code 39 Joint C ³ Curricular Office Naval Postgraduate School Monterey, California 93943-5000	1
5. National Security Agency ATTN: A213, Mona Guilfoil 9800 Savage Road Fort George G. Meade, Maryland 20755-6000	1
6. TRADOC Research Analysis CTR ATTN: (TRDC-FSC-J) Mr. Hugo Meyer Fort Leavenworth, Kansas 66027	1
7. Lt. S.K. Snyder, USN 3177 N.E. 88 Avenue Portland, Oregon 97220	1
8. Superintendent, Code 54JS ATTN: Prof. Carl Jones Naval Postgraduate School Monterey, California 93943-5000	1
9. Superintendent, Code 39 ATTN: LTC Jack Malokas Naval Postgraduate School Monterey, California 93943-5000	1

**DAT
ILM**