

AD-A181 899

DATA TELEMETRY ASSIMILATION AND OCEAN MODELING(U) WOODS 1/1  
HOLE OCEANOGRAPHIC INSTITUTION MA D E FRYE JUN 87  
MHOT-87-21 N00014-86-K-0751

UNCLASSIFIED

F/G 25/1 NL

END  
DATE  
PAGE  
23

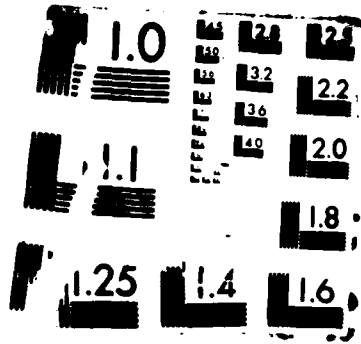

AD-A181 899

WHOI-87-21

**DATA TELEMETRY, ASSIMILATION  
AND OCEAN MODELING**  
Semi-Annual Report  
for the Period October 1, 1986 to April 1, 1987

Office of Naval Research  
University Research Initiative Program

Woods Hole Oceanographic Institution  
Massachusetts Institute of Technology  
Harvard University

Edited by

Daniel E. Frye

June 1987

**Technical Report**

Prepared for the Office of Naval Research under  
contract Number N00014-86-K-0751.

Reproduction in whole or in part is permitted for any purpose of the  
United States Government. This report should be cited as:  
Woods Hole Oceanog. Inst. Tech. Rept., WHOI-87-21.

Approved for publication; distribution unlimited.

**Approved for Distribution:**

  
\_\_\_\_\_  
Robert C. Beardley, Chairman  
Department of Physical Oceanography

ABSTRACT

The University Research Initiative Program is a cooperative project between Woods Hole Oceanographic Institution, Massachusetts Institute of Technology and Harvard. The objectives of this 5-year Office of Naval Research funded program are to advance the state of the art in ocean data telemetry, interpretation of remotely sensed data from satellite, and numerical modeling of ocean circulation. Ocean data telemetry is being addressed by several development projects whose aim is to reliably transfer data from in situ oceanographic instruments to laboratory computers on the shore. The satellite oceanography group is developing expertise in analyzing, manipulating, displaying and archiving data from all of the major satellite oceanographic sensors. The numerical modeling initiative is working on a family of circulation models which can be connected at their boundaries to cover the important mesoscale and basin wide flow regimes. These ambitious plans are intended to bring new technologies developed in the communications, electronics, satellite sensing and computer science fields into everyday use in oceanography so that they can be ready for the global science programs planned for the 1990's.

Accession For		
NTIS	CRA&I	<input checked="" type="checkbox"/>
DTIC	TAB	<input type="checkbox"/>
Unannounced		<input type="checkbox"/>
Justification		
By		
Distribution/		
Availability Codes		
Dist	Avail and/or Special	
A-1		



## TABLE OF CONTENTS

	Page
ABSTRACT	i
1. INTRODUCTION	1
2. TELEMETRY PROJECT	5
2.1 Management	5
2.2 Project Objectives	5
2.3 Major Tasks	7
2.3.1 STEM	7
2.3.2 S-Tether	12
2.3.3 Sound Link	14
2.3.4 HF/VHF Packet	14
2.3.5 Data Dissemination	16
2.3.6 POP-UP Buoy	17
2.3.7 Data Capsule	19
2.3.8 Scientific Liaison	20
3. REMOTE SENSING INITIATIVE	22
3.1 Hardware	22
3.2 Software	22
3.3 Networking	23
3.4 Users' Group	23
3.5 Education	23
3.6 Acquisition of Data Sets	24
4. MODELING INITIATIVE	25
4.1 WHOI Progress	25
4.2 MIT Progress	26
4.3 Harvard Progress	28
5. FOCUS PROJECT	30
6. NAVY LABORATORY INTERACTION	31
7. REFERENCES	33

## LIST OF FIGURES

	Page
1-1. URIP organization chart	3
2-1. Telemetry Project network diagram	8
2-2. Surface telemetering mooring (STEM) design	10
2-3. STEM schedule	11
2-4. Technical approaches to telemetering subsurface sensor data to satellite	13
2-5. Winch module design for the POP-UP Buoy	18

## 1. INTRODUCTION

The University Research Initiative Program being conducted at Woods Hole Oceanographic Institution (WHOI), Massachusetts Institute of Technology (MIT) and Harvard is one of a number of such programs awarded to educational institutions for research into new areas in oceanography (ONR, 1986). It is funded through the Office of Naval Research (ONR) Environmental Sciences Directorate in the area of Ocean Remote Sensing and Modeling for a period of five years. The purpose of the program is to make fundamental improvements in how we collect and assimilate oceanographic data and how we use it to model ocean circulation. Its goal is to take advantage of recent advances in communications technology and satellite-borne sensors which observe the ocean from space to improve both the quantity of data collected and the efficiency with which it is collected. Concurrently, improved, easy-to-operate numerical models are being developed which utilize the power of modern high speed computers. These models cover regional to basin wide scales and will form a hierarchy which can be used separately or together to model a broad range of ocean circulation scales.

To advance the program goals, the URIP is concentrating on three areas of technical development: telemetry of data from in situ ocean sensors, collection, processing and analysis of satellite-sensed data, and numerical modeling of ocean circulation. The Telemetry Project is pursuing a number of approaches to solve the problem of telemetry of data from in situ oceanographic sensors. These approaches include conventional surface and subsurface moorings with hardwired instrumentation, acoustically connected sensors and satellite transmitters, and expendable data capsules which are released and float freely away from a moored instrument array. The Remote Sensing Initiative is working to learn how to acquire and use the vast quantities of data which are or will soon be available from various satellite-borne sensors which observe the oceans. Important sensors which will be coming on-line over the next couple of years include the NSCAT and ERS-1 scatterometers, the altimeters on GEOSAT, TOPEX/POSEIDON and ERS-1, and various synthetic aperture radars



(ERS-1, SEASAT and SIR-B). Learning how to use these data and training student-scientists in their use is a primary goal of the remote sensing work.

The Modeling Initiative involves the development of a collection of models coupled to an open-ocean Regional Eddy Resolving Model. Surface and Bottom Boundary Layer Models as well as Coastal Boundary or Shelf Models can be coupled to the Regional Model which may itself be embedded in a General Circulation Model. It is anticipated that this modular approach to the different modeling scales will produce both better models and ones which can be applied to a broad range of problems and used by a broad base of researchers.

Figure 1-1 illustrates the organization of the URIP by institution and technical component. MIT is involved in the Remote Sensing and Modeling Initiatives with Drs. Carl Wunsch and Paola Rizzoli acting as Principal Investigators. Dr. Allan Robinson is leading the Modeling Initiative at Harvard where the major focus is on an operational model of the Gulf Stream region. Researchers at WHOI are involved in all three components of the program. Dr. Melbourne Briscoe is the Principal Investigator for the Telemetry Project, Drs. Kathryn Kelly, Nick Fofonoff and Hans Graber are P.I.s for the Remote Sensing Initiative, and Drs. Dave Musgrave, Dale Haidvogel (now at Johns Hopkins University) and Breck Owens are leading the Modeling Initiative. Overall Program Management is the responsibility of Drs. Robert Beardsley and Breck Owens. In addition to the three primary institutions involved in the URIP, a major subcontract is in place at Charles Stark Draper Laboratories for the Telemetry Project under the direction of Mr. John Dahlen for the development of the POP-UP Buoy. A small subcontract is also in place with Lamont Doherty Geophysical Observatory (LDGO) for development work on the Data Capsule project. A second small subcontract is in the planning stages for additional work on the Data Capsule project at the University of New Hampshire.

This report is the first of a series of semi-annual reports describing the progress made on the WHOI-MIT-Harvard URIP. It was edited by D. Frye, Telemetry Project manager, with contributions from the following investigators.

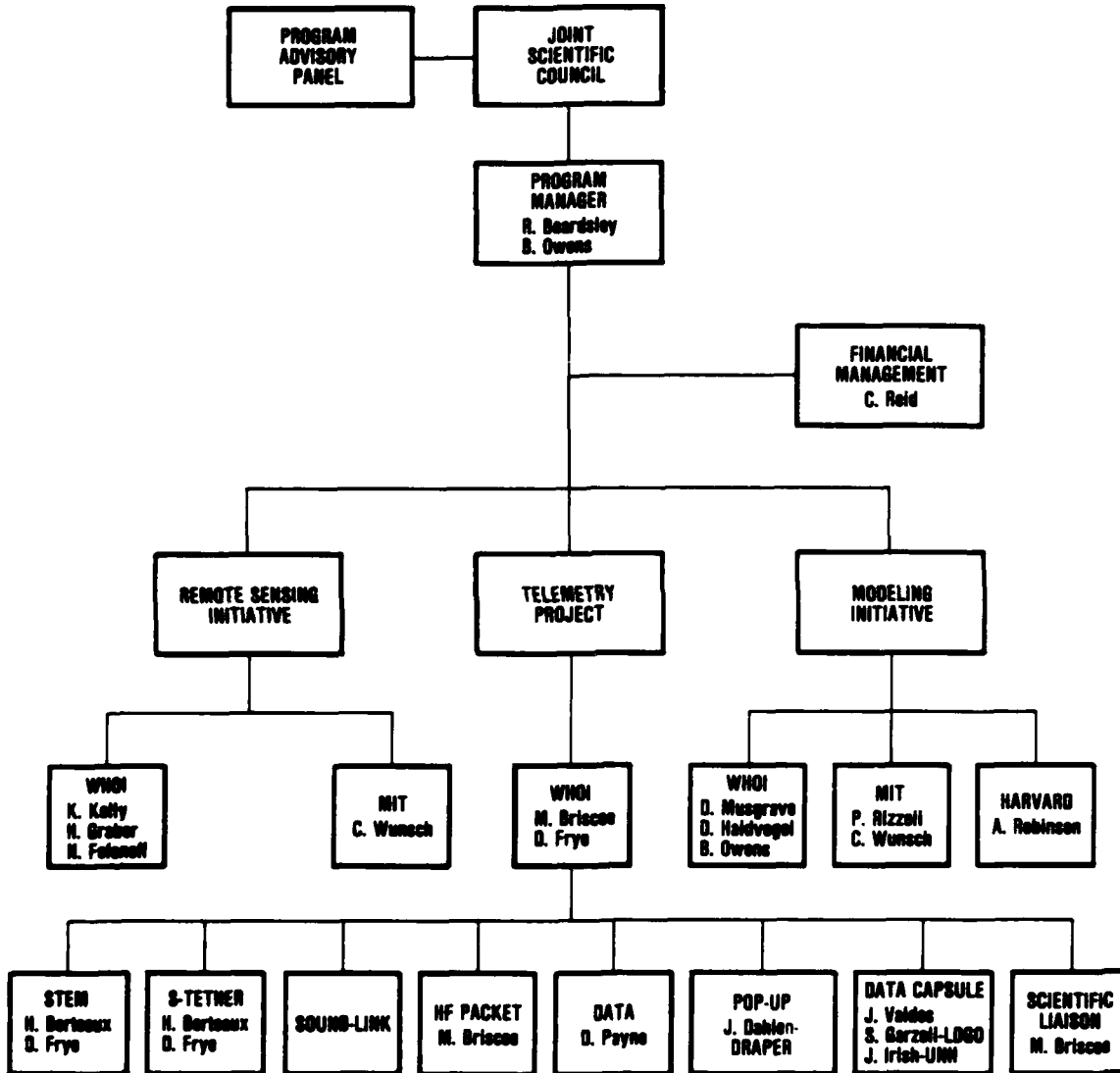

Figure 1-1. URIP organization chart

- R. Payne - Data Dissemination (2.3.5)
- J. Dahlen - POP-UP Buoy (2.3.6)
- K. Kelly - Remote Sensing Initiative (3.1-3.6)
- H. Graber - Remote Sensing Initiative (3.1-3.6)
- N. Fofonoff - Remote Sensing Initiative (3.1-3.6)
- D. Musgrave - WHOI Progress (4.1)
- B. Owens - WHOI Progress (4.1)
- P. Rizzoli - MIT Progress (4.2)
- A. Robinson - Harvard Progress (4.3)

Future reports will be available at about six months intervals with technical reports and journal articles describing specific research projects in more detail published separately.

## 2. TELEMETRY PROJECT

(D. Frye)

### 2.1 MANAGEMENT

A management plan for the Telemetry Project has been developed to improve the probability of accomplishing the project's objectives and to make it possible to track and control the work as it progresses. The following steps have been completed in the development of this plan.

- Definition of program objectives
- Identification of the technical approaches capable of meeting the objectives
- Determination of the budgets, schedules and resources required under each technical approach
- Preparation of a detailed work plan for each technical approach being pursued.

### 2.2 PROJECT OBJECTIVES

An initial set of seven objectives has been defined which direct the work on the Telemetry Project over the first two years of the program. These objectives will be refined and modified as the project moves forward. The seven objectives are:

1. Develop operational, practical systems for telemetering data from moored instrument arrays using existing satellite telemetry links. These systems should have the following characteristics.
  - Operating life of at least one year
  - Data throughput rate of 0.1 to 1.0 bit/s averaged over the deployment life
  - Global capability except for harsh or hazardous environments
  - Full depth capability

2. Develop a practical means of telemetering data from moored instrument arrays in harsh or hazardous environments where a constant surface expression is not possible or not desirable. These systems should have the following characteristics.

- Operating life of at least one year
- Data throughput of at least 0.1 bit/s
- Global capability

3. Develop techniques to increase telemetry data rates from open-ocean buoys to meet the requirements of medium data rate instrumentation arrays. Systems which meet this objective should have the following characteristics.

- Operating life of at least one year
- Data throughput rate between 1.0 and 100.0 bits/s
- Global capability

4. Develop a long term telemetering mooring to meet the demands for multi-year instrument deployments with the characteristics shown below.

- Operating life of up to 5 years
- Data throughput of at least 0.01 bit/s
- Global capability except for harsh or hazardous environments
- Utilizes mooring technology and sensors developed on concurrent projects

5. Develop an operational, practical data collection and dissemination system for telemetered data which can:

- Provide global, near real time access to an incoming data stream
- Edit, calibrate and partially process data prior to dissemination
- Operate in an automatic mode requiring little or no manual intervention

6. Make the techniques developed on the project available to a wide range of scientists. Perform the advocate's role in establishing telemetry as a practical scientific tool. This objective requires the following:

- Define and perform target studies using various telemetry techniques
- Evaluate the results of both the technology development and the target studies through published reports and articles
- Commercialize the hardware components where feasible

7. Evaluate the potential for the telemetry of tomographic data from moored and drifting sensors.

### 2.3 MAJOR TASKS

The project planning stage has resulted in the definition of eight major tasks which are shown in Figure 2-1. These tasks are designed to lead to an operational telemetry capability over the course of two or three years. It is anticipated that some of the technical approaches will prove to be unreliable or too difficult to implement at sea and these will be dropped in favor of the more realistic approaches as the project proceeds. New tasks will also be added as the project priorities change and as some of the original problems are solved. A brief description of each of the planned tasks follows.

#### 2.3.1 STEM (SURFACE TELEMETRY MOORING)

Surface moorings will be evaluated and tested for use as platforms for telemetering data from moored instrument arrays. As a first step, the discus buoy being deployed offshore Bermuda for cable and connector tests by the Ocean Engineering Department (under the direction of H. Berteaux) will be instrumented with telemetry equipment. The instrumentation will include two Vector Measuring Current Meters (VMCMs) which have been configured for telemetry by the Buoy Group, a meteorological sensor package and a system controller interfaced to the sensors and telemetry

# Telemetry Project Network Diagram

## TECHNICAL APPROACHES

## GOALS

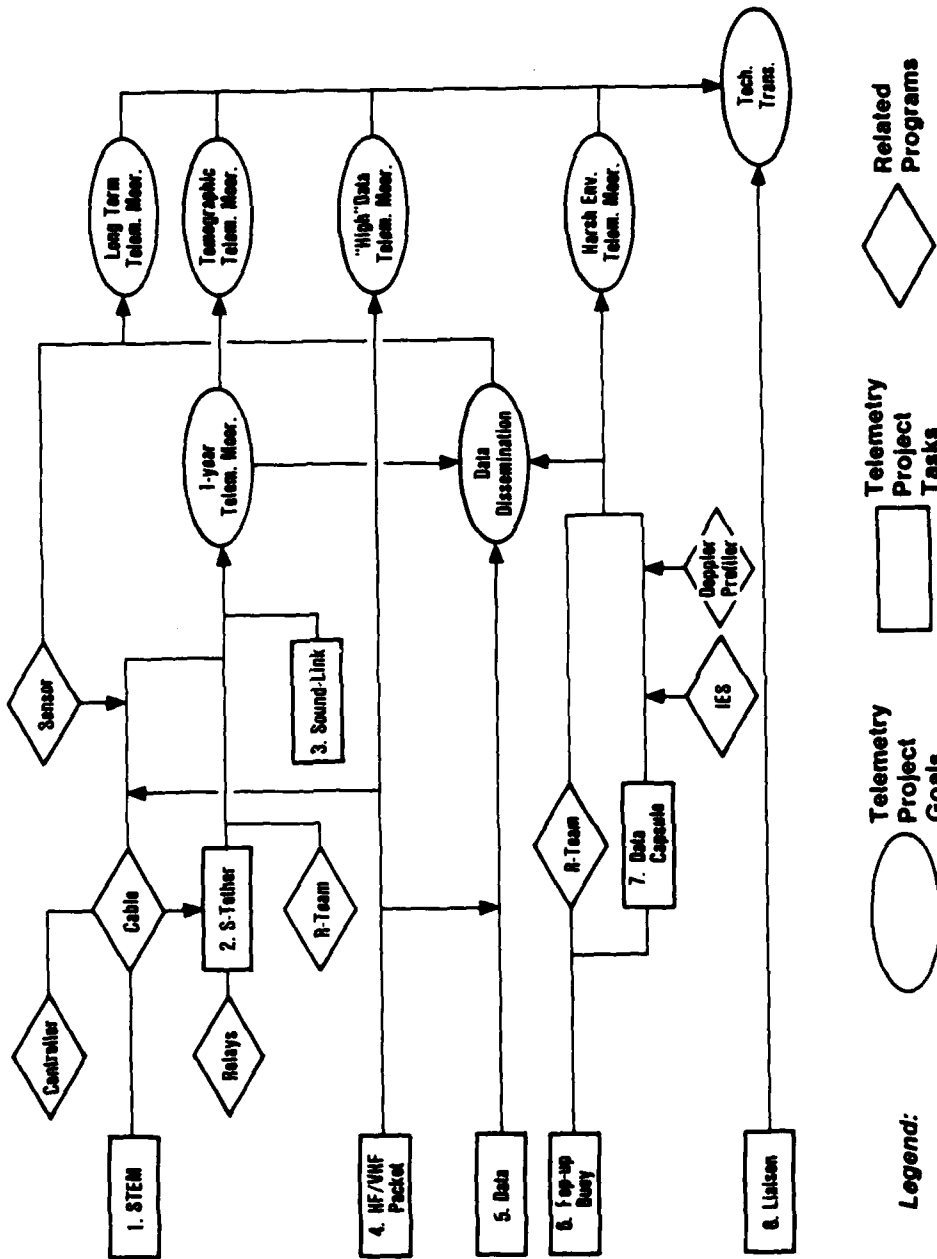

Figure 2.1. Telemetry Project network diagram

devices. The controller is identical to the controller developed on the R-Team Project under separate ONR funding. Telemetry will be accomplished via Argos and GOES transmitters. The discus mooring will be deployed in October 1987 offshore Bermuda. This will allow for unscheduled servicing by the research vessel stationed at the Bermuda Biological Station. Data from the current meters at 10 and 1000 m as well as wind velocity, barometric pressure, air temperature and relative humidity will be monitored by scientists at WHOI to evaluate system performance. The Bermuda test mooring will be retrieved in March 1988.

In addition to taut-moored surface techniques, such as STEM, the use of slack surface moorings such as those used by the National Data Buoy Center (see May, 1986), low cost surface moorings and hybrid surface/subsurface moorings will also be investigated. Test systems utilizing these alternative approaches may be developed, depending on the results of the Bermuda tests and the scientific needs for the other systems.

#### Progress to Date

Preliminary design of the STEM test configuration has been completed (Figure 2-2). Instruments on the buoy and on the mooring are hardwired to the controller which uses the SAIL protocol for communication. The controller processes data collected and outputs a compressed version to the GOES transmitter. A further compressed version of these data is output to an independent Argos transmitter. Design of the mooring, cables and connectors for this test is well underway as is the ordering of the instrumentation and telemetry equipment. The controller and interface software development is waiting for Ocean Engineering personnel to become available. The present schedule (Figure 2-3) calls for all systems to be completed by the end of August with a one-month system test preceding deployment on October 15. The R/V Oceanus will be used for the deployment operation on a cruise shared with the R-Team mooring retrieval. The deployment site is located in 3000 m of water offshore Bermuda.



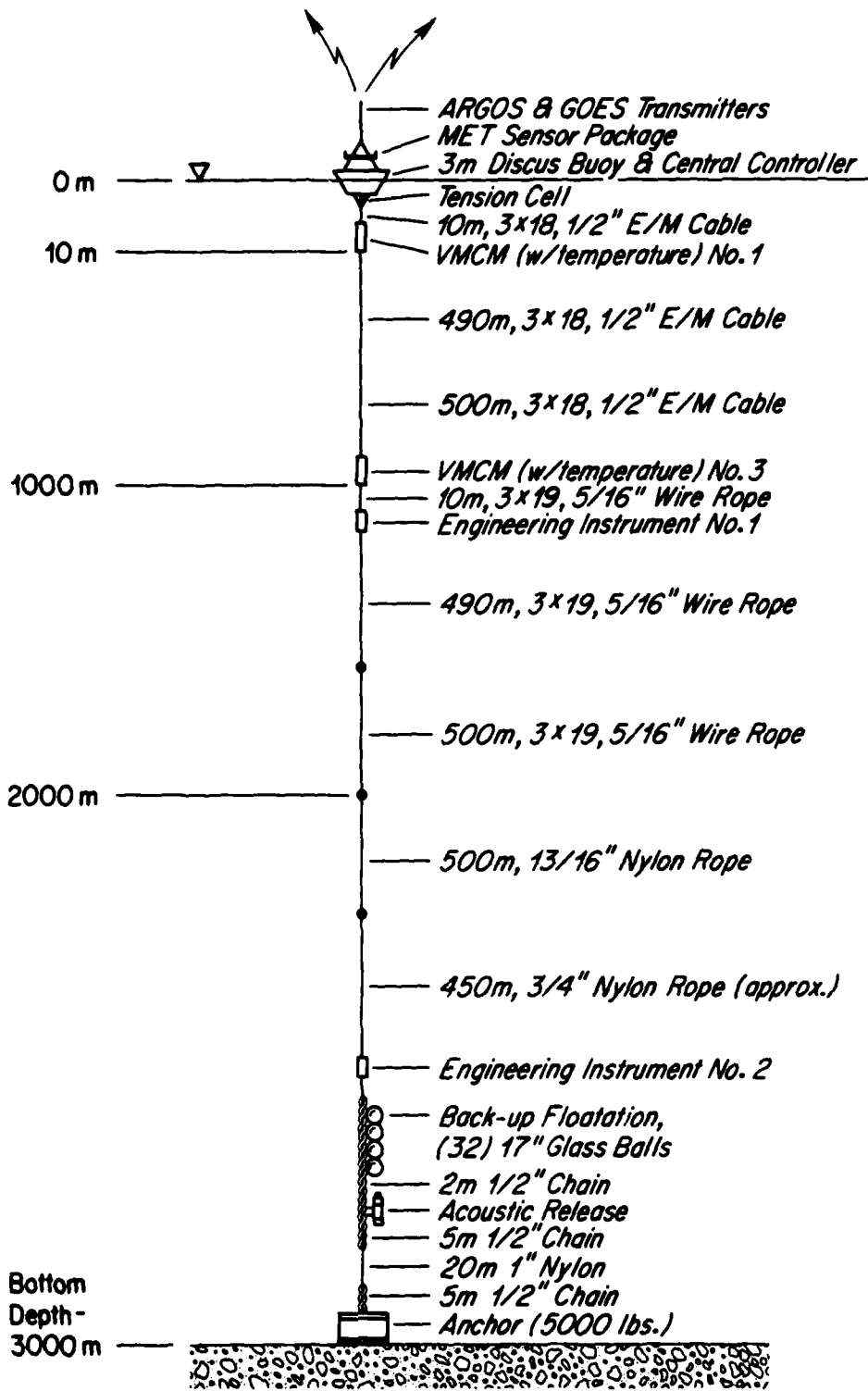

Bermuda Test Site: 32° 13' N - 64° 33' W

Figure 2-2. Surface Telemetry Mooring (STEM) design

# STEM Schedule Diagram

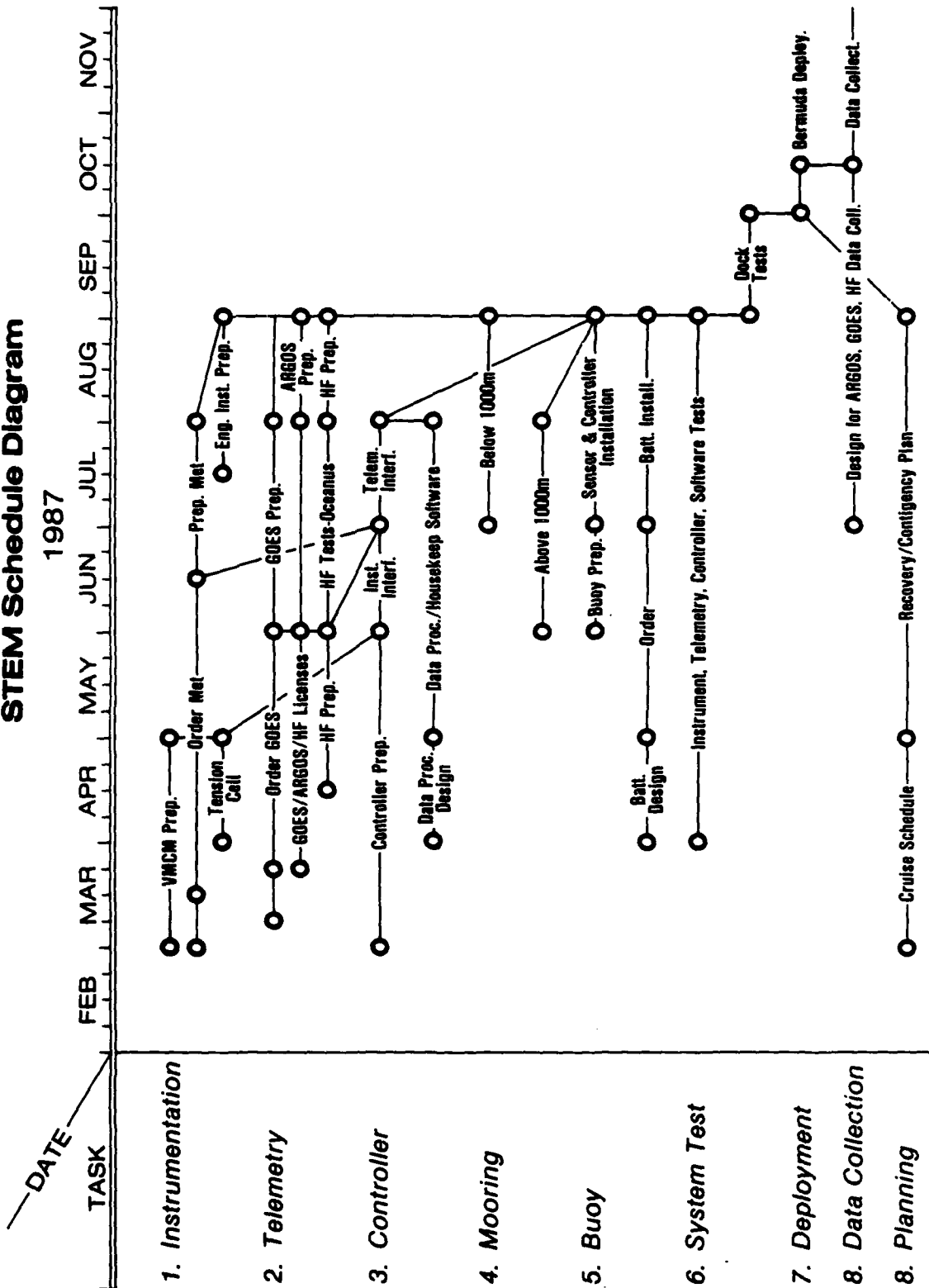

Figure 2.3. STEM schedule

### 2.3.2 S-TETHER

An S-Tether surface mooring (Figure 2-4) capable of telemetering data from a subsurface mooring will be designed in 1987 with an initial test mooring planned for installation in the Fall. This system is based on previous work done by the Ocean Engineering Department during the RELAYS project (Walden and Berteaux, 1983) with the added constraint of minimizing the cost of the hardware components. Initial testing will be performed on a prototype S-Tether deployed at the Buoy Farm in late 1987. Results of this 6-month test mooring will be used as the basis for a more complete mooring equipped with sensors, controller and satellite telemetry which is planned for a one-year deployment beginning in 1988. This second phase may be conducted jointly with the Ocean Engineering Department and will lead to an operational capability in 1989 if the initial offshore tests are successful.

#### Progress to Date

Preliminary design work on a prototype S-Tether mooring has been completed and several candidate designs identified. These designs are now being modelled under specified current and wave regimes to determine which design provides the highest probability of success over the broadest range of environmental conditions. The modeling work is being performed under the direction of H. Berteaux in the Ocean Engineering Department. The preliminary design specification calls for the system to meet or exceed the following requirements.

Maximum water depth:	6000 m	
Maximum wave height:	20 m	
Operational Current Profile:	surface - 1.5 Knot (linear decrease with depth)	
	50 m	1.0
	500 m	0.5
	1000 m	0.25
	2000 m	0.1
	6000 m	0.1

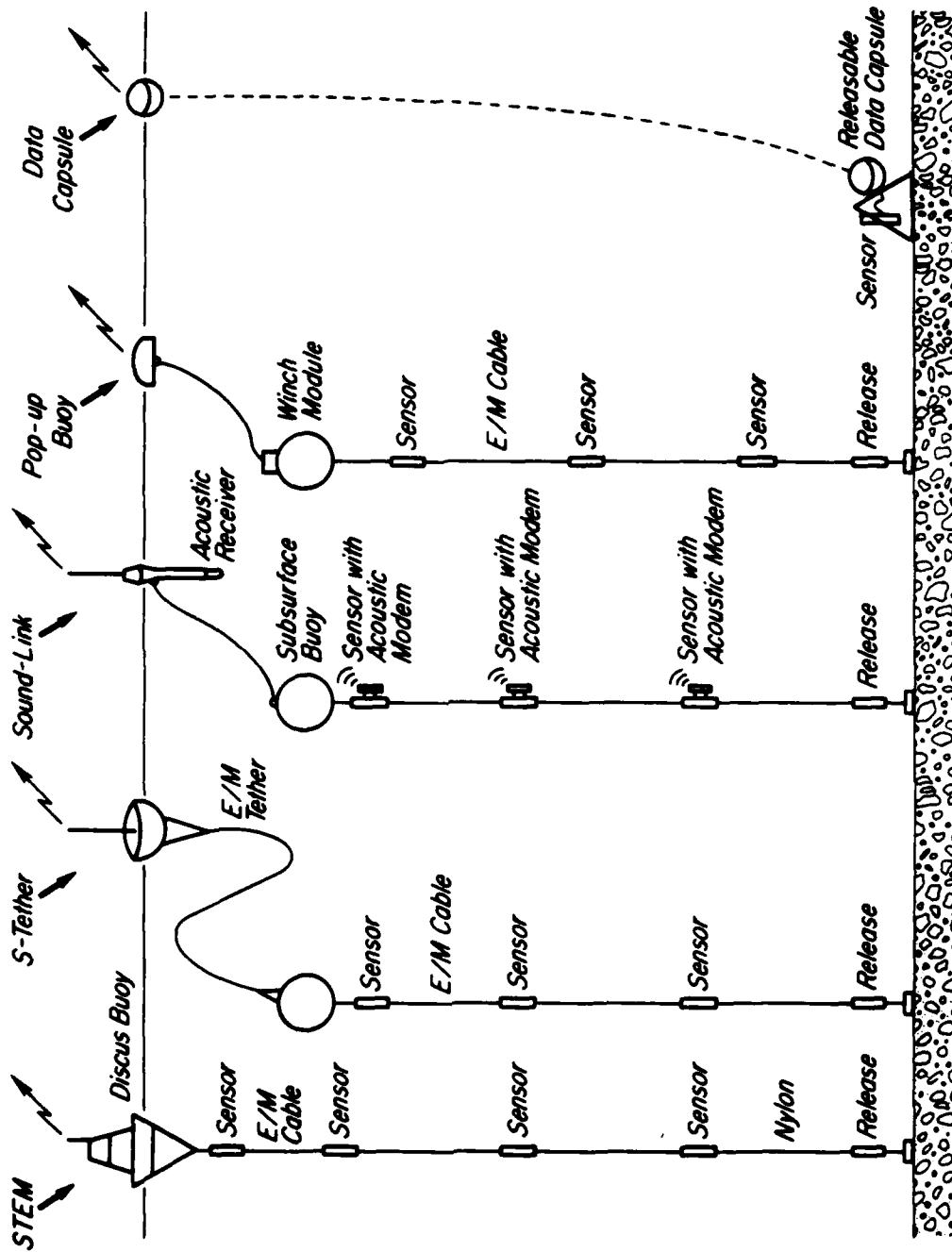

Figure 2-4. Technical approaches to telemetering subsurface sensor data to satellite

Survival Current Profile: surface -	2.5 knot
50 m	1.5
500 m	1.0
1000 m	0.5
2000 m	0.2
3000 m	0.1
6000 m	0.1

S-Tether to be fishbite resistant

Surface buoy to be capable of supporting solar panels and a 200 pound payload.

Hardware for the Buoy Farm tests has been ordered and fabrication of the surface buoy has begun. Design of the tether terminations and buoy instrument payload is underway.

### 2.3.3 SOUND LINK

As a second approach to the hardwired moored systems, an acoustic data link will be evaluated as a means of transmitting data vertically from a moored instrument array to a surface buoy. If the results of this study indicate that a practical and economical system is feasible which can operate to 5000 m depths and provide appropriate data transfer rates at reasonable power levels, then a specification will be written to form the basis of an acoustic modem design. Responses from internal sources and commercial vendors to this specification will be solicited, and if one of these sources offers a high probability of meeting the specification, then work will begin to design and build several acoustic modems for delivery to the program in 1988. Testing of this equipment would begin in late 1988 or early 1989.

#### Progress to Date

Work on the Sound Link task has not yet begun. It is anticipated that engineering development will not begin until 1988.

### 2.3.4 HF/VHF PACKET RADIO

This task involves the evaluation of various high data rate telemetry schemes for getting data from a surface buoy to shore. The

first phase of this project has already taken place during a cruise on the R/V De Steiguer when M. Briscoe tested HF packet equipment as a long distance communications tool. The second phase of the HF work is the installation of a remote station on the R/V Oceanus in June this year and the establishment of base stations at WHOI and Texas A&M. Following range and reception tests from the Oceanus, an evaluation of the HF system for buoy applications will be made and appropriate equipment identified or specified. Concurrent with the HF work, a VHF packet system has been installed on Martha's Vineyard to transfer wave data from a Waverider buoy at the Buoy Farm to Clark Laboratory. This system began operation in April 1987. Its purpose is to provide wave data relevant to the Ocean Engineering Department's mooring tests, to gain some experience with the use of packet radio links, and to provide a data stream for the Data Dissemination Task.

#### Progress to Date

Initial tests of the HF Packet techniques were conducted by M. Briscoe from the De Steiguer while cruising in the North Pacific in October 1986. Results of these tests are being analyzed at this time. Equipment for additional tests to be performed from the Oceanus beginning in June 1987 is being installed. In addition discussions have taken place with Science Applications International Corporation concerning use of their meteorburst master station. Based on this, we plan to perform simultaneous HF packet and meteorburst communications experiments onboard the Oceanus this summer. This will be an important intercomparison since it will provide a direct comparison of the data throughput and power requirements for each technique under identical conditions. Previous estimates of 1-50 bits per second at power levels of 0.2 - 10 joules per bit (Briscoe, 1986; Briscoe and Frye, in press) can then be verified and the feasibility of using these methods as general purpose buoy telemetry techniques evaluated. HF license applications have recently been acted on by the FCC; WHOI has been authorized as KB2XBD to use HF packet in an experimental program on the 4-22 MHz ocean data telemetry bands.

The Waverider buoy deployment planned for April 1987 has been carried out and the buoy is presently in the water about 10 miles

offshore Martha's Vineyard. The offshore components are working well. The Gay Head receiving station has been installed and is operational. Tasks yet to be accomplished include final configuration of the receiving station at the Clark Building and software development for data dissemination.

#### 2.3.5 DATA DISSEMINATION (R. Payne)

Methods for collecting, processing and disseminating telemetered data are being developed under this task by R. Payne. The initial data set consists of wave data from the Buoy Farm which is being sent to WHOI from Martha's Vineyard via a dedicated VHF packet radio system. Wave data is being logged at WHOI and then processed to produce wave spectra and wave statistics. Processed data are then made available to potential users, such as the local Coast Guard forecaster and the Ocean Engineering Department, via telephone modem connection, and will soon be available on the WHOI node of SPAN and NSF net.

This system will be expanded in October 1987 to include data collected by Service Argos and by NESDIS (from GOES) which will be transmitted from the surface buoy deployed off Bermuda. Data from the Argos transmitter will also be collected using WHOI's Local User's Terminal (LUT) and these data will be incorporated into the data dissemination system.

#### Progress to Date

The initial phase of the Data Dissemination Task is the half-hourly collection, processing and dissemination of the wave data transmitted from the Buoy Farm since April. A computer was purchased to control this system and software is being tested which collects the data coming over the VHF packet link and edits and processes it to produce both statistical and spectral summaries. The following products are transmitted to the WHOI RED VAX for archiving and dissemination to interested parties:

- Significant wave height
- Maximum wave excursion
- Mean wave period

- Zero-up-crossing wave period
- Period of the spectral peak

This system should be fully operational by the end of May.

#### 2.3.6 POP-UP BUOY (J. Dahlen)

The POP-UP Buoy is designed to relay data between a subsurface buoy and a satellite (Figure 2-4). It consists of a winch module (see Figure 2-5) located at the top of a subsurface mooring and a transmitter module that can ascend to the ocean surface by its own buoyancy and which is hauled down to rest atop the winch module for the long periods between transmissions. The winch module weighs 164 kg and stores sufficient energy to cycle the transmitter module 700 times to the surface from 60 meters depth in a 60 cm/s current. It contains all the components required to operate the winch, receive data from sensors via acoustic or hardwire links, process, store and transfer data to the transmitter module and to govern system operation. The transmitter module weighs 36 kg and contains the necessary antenna, transmitter, energy supply and data transfer and storage equipment to transfer its stored data to a polar orbiting satellite. The entire system is rated for 400 meters pressure in the event of extreme mooring excursion.

During 1987, a prototype POP-UP Buoy will be designed and built at Draper Laboratories under the direction of J. Dahlen; it will demonstrate the ascent/descent operations of the surface buoy module and the ability of the buoy to act as a telemetry platform over a broad range of ocean conditions. At-sea tests will be performed to demonstrate the operation of the prototype system. Also during 1987, decisions concerning the most appropriate ways to link the winch-module controller to the data from the subsurface instrumentation will be made. Where possible, items such as the system controller, mooring components, data transfer techniques and satellite telemetry techniques will be standardized among the POP-UP Buoy, S-Tether, STEM, Data Capsule and Sound Link Projects. Plans for 1988 include continued development of the POP-UP Buoy to develop the subsurface data link and the link between the winch module and the surface buoy.



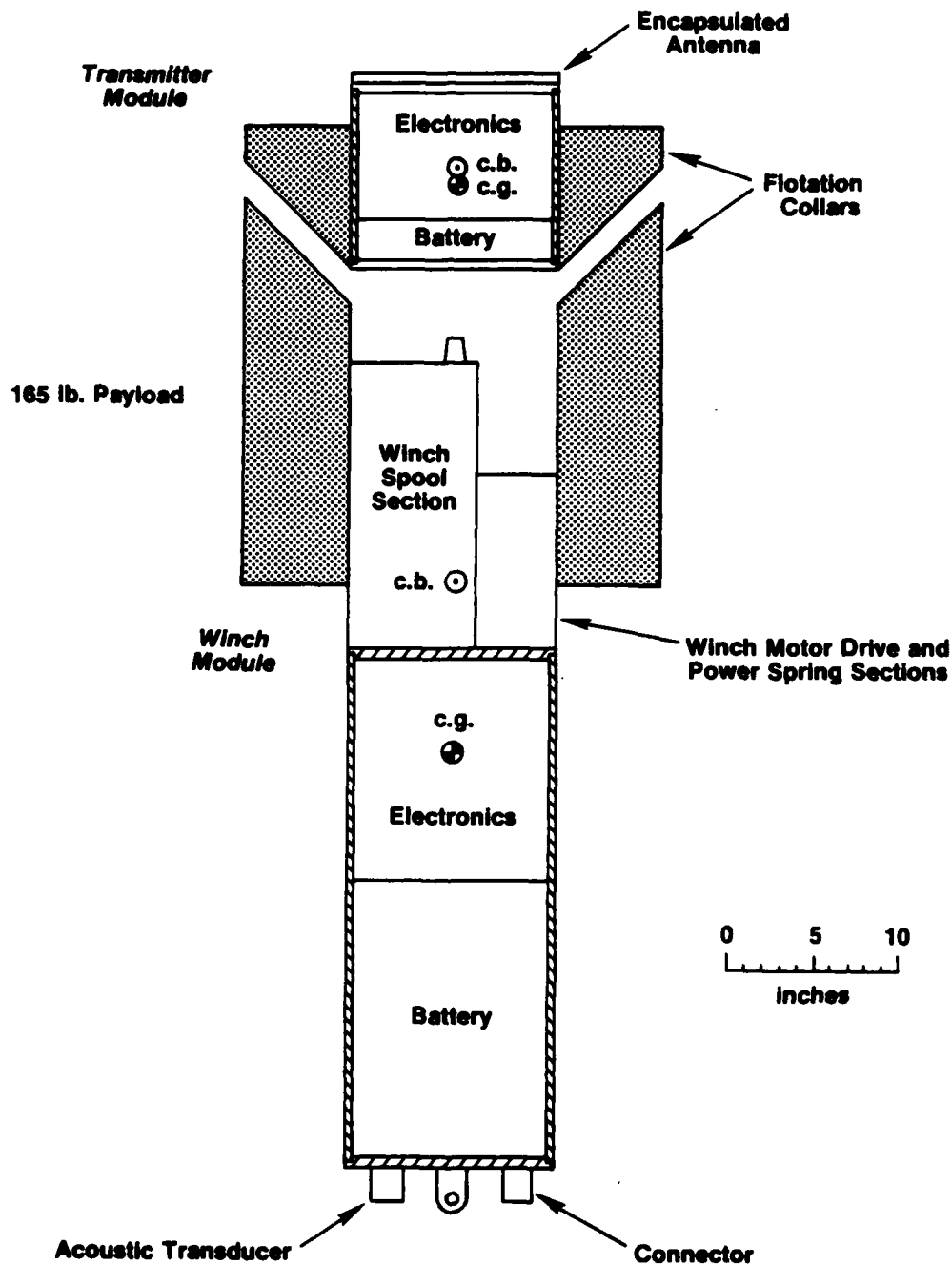

Figure 2-5. Winch module design for the POP-UP buoy

### Progress to Date

The objective for the first year is to assemble and test the basic electro-mechanical design of the POP-UP Buoy. At this time, most of the components of the winch module have been fabricated and the torque motor operation has been verified. The motor and control electronics have been designed and are being assembled. Software for the controller is nearing completion. Mechanical design of the remaining parts of the winch module is underway and the pressure housing materials are ready for machining.

Mechanical design of the transmitter module has begun and its pressure housing materials are ready for machining. The Argos transmitter and antenna are ready for use. Flotation collars for both modules have yet to be designed and are awaiting results of a materials testing program. At-sea tests are planned for Fall 1987 to be conducted in Massachusetts Bay by Draper Laboratories.

### 2.3.7 DATA CAPSULE

A preliminary design for a data capsule capable of providing occasional updates from bottom-mounted instrumentation will be developed in 1987. Work on packaging and the capsule electronics will begin. A subcontract to Lamont Doherty has been let for the design of an interface between Lamont's inverted echo sounder (IES) instrument and the WHOI-developed data capsule. A similar subcontract to the University of New Hampshire is being discussed to allow work to begin on an interface between an acoustic doppler current profiler (ADCP) and the data capsule. Tentative plans call for testing of prototype data capsules with moored current meters and bottom mounted instruments in 1988. If these tests are successful, then work on a multiple capsule approach will begin.

### Progress to Date

J. Valdes is working on a preliminary design for a one-shot data capsule which provides a stand-alone capability to interface with any SAIL-equipped instrument. Plans call for use of an Argos transmitter equipped with 64 k bytes of memory to be housed inside a 17-inch glass

ball. Initial discussions indicate that a burn-wire will be evaluated both to transfer data and to release the capsule. Tasks to be performed in the near future include coordination meetings with Lamont Doherty and University of New Hampshire personnel and start of the electrical and mechanical design tasks.

A subcontract with LDGO is in place to interface their IES instruments to the data capsule developed at WHOI. Work there has begun on:

1. Development of software for data compression algorithms within the IES.
2. Optimization of the communications channel such that more frequently observed conditions are assigned the shortest codes.
3. Modification of the existing IES release mechanism for use with multiple data capsules.

J. Irish and N. Pettigrew at the University of New Hampshire have submitted a proposal to develop an interface between a bottom-mounted acoustic doppler current meter and the data capsule. A subcontract is being written to fund this work under the URIP.

#### 2.3.8 SCIENTIFIC LIAISON

An ongoing effort to stay abreast of telemetry technology, to disseminate the results of the developments taking place on this project, and to identify scientific projects suitable for initial telemetry tests is underway. Participation in specific conferences, workshops and other forums will be identified, and a list of experiments on which telemetry would be a useful addition will be developed. Telemetry project participants will perform an advocate's role in trying to get telemetry used in operational programs.

In addition, continuing efforts to make the hardware developed on the project available to scientists at other institutions will be made. These efforts will take two forms. One will be to cooperate, where possible, with scientists needing telemetry capabilities on projects within and outside of WHOI. The other will be to make use of commercially available components in designing the hardware or to commercialize major subsystems of the hardware so that telemetry systems

can be built outside of WHOI without requirements for extensive development work.

Progress to Date

Only initial progress has been made on this task to date, though numerous discussions with scientists at WHOI and other oceanographic institutions have taken place. D. Frye visited NDBC, NORDA, NAVOCEANO and the University of S. Mississippi to discuss the Telemetry Project in March. Follow-up to these discussions will occur over the next few months. M. Briscoe has requested expressions of interest from ocean scientists interested in the Telemetry Project via telemail and a number have been received. Follow-up to these responses has just begun. Below is an initial list of programs that might have future cooperation with this URIP; the list is not complete nor meant to represent commitments by any party.

- SYNOP - N. Hogg, WHOI
- SUBDUCTION - J. Price, WHOI
- GOPS - V. Aspen, U. of S.M.
- URI - K. Vallis, Scripps
- AMASSEDS - R. Beardsley, WHOI
- - J. O'Brien, FSU
- BIOSPAR - P. Wiebe, WHOI

### 3. REMOTE SENSING INITIATIVE

(N. Pofonoff, H. Graber and K. Kelly)

#### 3.1 HARDWARE

The SUN Microsystems workstation, purchased to archive and process satellite data, arrived and began operation as the "SOLARMAX" node in January, 1987. The computer is connected via Ethernet to the Institution VAXes and to external nodes by SPAN and other networks. It is also connected to a SUN 3/160 workstation in the Ocean Engineering Department, used by Graber and purchased with funding from NASA for the NSCAT project. Two additional black and white diskless workstations have been ordered for the URIP SUN system. Data is currently transferred to the workstation via the RED VAX over Ethernet. Sample data sets consisting of IR images, wind vectors and bottom topography have been transferred for program development and testing. As the workload increases, additional nodes and remote terminals will need to be added. A printer and plotter are needed to provide hard copies of output and plots. A 6250 dpi tape drive will be needed to load and store the larger data sets. These hardware items will be ordered as suitable models capable of meeting the requirements are identified.

#### 3.2 SOFTWARE

Software development has begun slowly but will be proceeding more rapidly with the hiring of a programmer. After an extensive search we succeeded in hiring Michael Caruso to do system administration, graphics development and applications programming. Mike will be supported by the satellite oceanography section of the URIP project and by the NSCAT project. Mike has a master's degree in mechanical engineering with experience in numerical modeling of fluid dynamics and in graphics software development. While searching for a programmer exclusively for satellite work, we borrowed a programmer who was experienced on the SUN workstation to create a simple software package to manipulate and display various types of satellite data. This software displays raster images (IR, CZCS or SAR), vectors (SASS, current meter or doppler acoustic

velocities), and track data (ship tracks, altimeter measurements or coastlines) or any combination of these data. The multiple window system allows simultaneous viewing of several graphics displays or viewing images in rapid succession to create a movie. In addition we are writing a simple on-line catalog, based loosely on the NODS catalog, to assist in archiving and searching for data. The general aspects of this software development are funded by URIP with those aspects directly related to using NSCAT data being funded by this project. A device independent window-management program (XWINDOWS), developed at MIT, is being studied for future use. This public domain program could facilitate exchange of software among the URIP researchers using different workstations (SUN, APOLLO, GPX, etc.).

### 3.3 NETWORKING

The SUN workstation is connected to computers at MIT and Harvard via the WHOI-MIT microwave link. A number of trials have been carried out sending mail messages, logging into remote nodes and transferring files. The transfer rates are high (30-56 kbyte/s) over the local Ethernet but are slower (10-15 kbyte/s) between the RED VAX and SOLARMAX. File transfers to the Harvard node were slower still (6-8 kbyte/s). IR image transfers from University of Rhode Island over the SPAN network are limited to rates of 9.6 kbyte/s taking about 4 minutes for a standard 512 pixel image.

### 3.4 USERS' GROUP

Weekly lunchtime meetings are being held at WHOI to discuss topics of interest among local users of satellite data. The informal sessions provide opportunities to exchange information about data sets and computer programs as well as provide a forum for discussion of problems and plans. Participants include members from other projects using remotely-sensed acoustic as well as satellite data sets.

### 3.5 EDUCATION

Two joint MIT/WHOI classes were taught on the microwave link during the 1986-87 academic year. The first course, "Principles and Physics of

Remote Sensing", focused on the fundamentals and operating principles and applications of IR radiometers, altimeters, synthetic aperture radars, scatterometers, passive microwave sensors and color scanners. The second course, " Application of Remote Sensing and Image Processing", was conducted as a computer lab with the objective to introduce students to handling real data sets and guide them through the basic rudiments of processing satellite data.

### 3.6 ACQUISITION OF DATA SETS

The following data sets for the SEASAT mission were obtained: (1) altimeter-derived wave heights and wind speeds colocated at all available NDBC buoys; (2) wave spectral data and other environmental measurements at all available NDBC buoys; (3) scatterometer wind vectors colocated with wind observations from NDBC, Australian ocean buoys, oil platform and weather ships; and (4) a 14-day period of scatterometer-assimilated global wind fields generated by the European Centre for Medium Range Weather Forecasting (ECMWF). Currently the 96 days of the objectively de-aliased global scatterometer windfields by R. Atlas are assimilated at the ECMWF into their numerical GCM model. We are plotting and processing the first month of GEOSAT altimeter data and have recently placed a subscription to NODC to obtain subsequent GEOSAT data for the entire year. In addition IR images of the Gulf Stream are also being collected to increase our archive of satellite oceanographic data sets.

## 4. MODELING INITIATIVE

4.1 WHOI PROGRESS (D. Musgrave and B. Owens)

We have implemented D. Haidvogel's primitive equation (PE) model on the WHOI VAXes. Several test problems have been studied to determine the accuracy and computational requirements of the PE model as a function of numerical resolution and physical parameters. These tests include barotropic shelf waves and baroclinic Kelvin waves to test the sigma-coordinate system and vertical spectral differencing, respectively. We have also included surface wind-forcing as a first step in coupling an upper-ocean model with the PE model.

We have discussed several methods of coupling an upper-ocean model with the PE model and have decided on a hierarchy of coupling schemes that range from simple and fast to sophisticated and slow. At the simple end of the spectrum we let the upper-ocean model dictate the number of grid points over which the surface forcing is distributed. At the sophisticated end, the density and vertical shear in the upper ocean are calculated by the upper-ocean model and passed to the PE model. Thus, one will be able to tailor the configuration of the model to suit the conflicting needs of fast calculation versus accurate response of the upper ocean to surface forcing.

An adaptation of the Hibler (1979) ice dynamics model with an active (prognostic) mixed layer has been developed. The ice dynamics model has been written for a b-grid with general orthonormal spacing. Initial timing indicates that it is slightly less than three times faster than the original Hibler model. Other refinements to the ice dynamics code includes the addition of a snow layer. The first prognostic mixed layer is the simple bulk model as formulated by Kraus and Turner (1967). A second model is also being tested that has an exponential profile of temperature and salinity in the second layer as formulated by Lemke (in press). This latter mixed layer model attempts to alleviate the difficulties of the Kraus-Turner model in which one gets excessive adjustments in the second layer due to the discontinuous jump between the two layers while still having relatively few parameters at each grid



point to describe the mixed layer. This modeling effort is aimed at low frequency problems, where inertial motions are not important. Initially this model is being coupled to a 1 and 1/2 layer primitive equation, with one active layer below the mixed layer and a bottom quiescent layer. The first problem that the model will address is the growth and retreat of the Weddell Sea ice sheet. This choice was made in large part because Owens is a visitor at the Max-Planck Institut fuer Meteorologie where the appropriate atmospheric forcing fields for the Weddell Sea are easily available. During the second year plans are to merge the model with the Haidvogel primitive equation model.

We are purchasing a computing system based on SUN workstations. Our decision was based on many factors but the final factor was compatibility with other components of the URIP. The next half year we will further test the PE model and develop the simplest coupling scheme in the above hierarchy. Conversion of the PE model to a SUN-based system will take significant time.

#### 4.2 MIT PROGRESS (P. Rizzoli)

The primitive equation model constructed by D. Haidvogel has been used in a thorough sensitivity study to explore the model response to different initializations and data assimilations. The model has been used in spin-down experiments in which the initial condition is a narrow jet with surface intensified transport. Five levels are used in the vertical and the parameter ranges used (total transport jet width, Brunt-Vaisala frequency, profile, vertical shear of the jet) are those characteristic of the Gulf Stream.

The first sensitivity study has been devoted to balanced versus unbalanced initializations. Two types of basic imbalances can be considered:

1. Dynamical imbalances, relaxing for instance:
  - 1a. the geostrophic constraint of no horizontal divergence
  - 1b. the hydrostatic constraint
2. Imbalances produced by partial knowledge of the initial fields related to partial data sets. For instance:

- 2a. hydrographic or tomographic data only for the interior density field. All other fields ( $u,v$ ) are zero at the initial time.
- 2b. same as in 2a but a partially balanced initialization can be achieved by evaluating the velocity shear geostrophically from the initial density field.
- 2c. only altimetric data are given, i.e., only the barotropic pressure is known at  $T = 0$ . The density field is zero at the initial time.

As is well known, the various types of imbalances produce initial "shocks" which manifest themselves in the excitation of internal gravity waves (the model has a rigid lid) and they represent undesired "noise" masking the scales of motion one wants to explore. To eliminate the initial "shock" a balanced initialization routine has been developed and attached as a "module" to the model. It consists of two successive steps:

1. At  $T = 0$  all the fields are initialized so as to be in mutual geostrophic and hydrostatic balance
2. At  $T = \Delta T$ , the first time step, the velocity field is still constrained to be in geostrophic balance for the horizontal velocity components (streamfunction field is geostrophic), but the vertical velocity is evaluated from quasi-geostrophy i.e., is of the order of the Rossby number.

Step 2 is the one which brings to zero the tendency for inertia-gravity waves to grow. The results of the initialization sensitivity study is that inertia-gravity waves are excited only when rather brutal initial imbalances are present. A simple initialization like the one above and even a simply geostrophically balanced initialization (only Step 1) seems sufficient to produced well-behaved jet evolutions over long spin-down experiments, with no significant gravity wave noise. The initialization shocks typical of meteorological models may constitute only a minor problem for the oceanographic case, possibly related to the difference between the two fluids and not only to the damping properties of the model used.

A second set of experiments is being completed with the assimilation of simulated data of a different type. Two specific data sets are being compared:

1. Only interior density (hydrographic data)
2. Only altimetry (barotropic pressure)

The model is first run in a basic experiment which constitutes the "reference" ocean from which data are measured. The model is successively run starting from a different ("wrong") initial condition, that is, 30 days later. Day 30 of the reference run is thus day 0 for the assimilation experiment. Data are injected starting from day 0 of the reference ocean according to (1) and (2). The forcing introduced by the data injection induces all the fields to converge to the reference ocean. Convergence is measured through different diagnostic tools such as the RMS error between the data assimilation run and the reference run. Due to the incompleteness of the assimilated data sets, the RMS error in the various fields decreases rapidly initially and levels off at a value which depends on the frequency in time and space of data injection. For a "perfect" data assimilation at every time step and every grid point, the typical time scale for the RMS error to level off is about 15 days. Experiments are now being carried out varying the assimilation time interval (and with linear interpolation between the two successive data injections) and reducing the spatial density of the data.

#### 4.3 HARVARD PROGRESS (A. Robinson)

The URIP has supported the following lecture series of visiting scholars. The lectures presented the fundamentals of the theory and practice of data assimilation and the meteorological experience and the implications in oceanography.

1. Professor Michael Ghil, Department of Atmospheric Sciences, UCLA  
 SEQUENTIAL ESTIMATION AND SATELLITE DATA ASSIMILATION IN  
 METEOROLOGY AND OCEANOGRAPHY
  - March 3 "Background and Use by Meteorologists"
  - March 4 "Theoretical Introduction to Sequential Estimation and Kalman Filtering"
  - March 5 "Special Topics - Initialization, Adaptive Filtering, Non-Linear Filters and Computational Aspects"

## 2. Dr. Robert N. Miller, Visiting Scholar, Harvard University

## THEORY AND PRACTICE OF DATA ASSIMILATION FOR OCEANOGRAPHY

- April 22 "Introduction and Overview"  
April 24 "Variational Inverse Methods"  
April 29 "Sequential Methods: Optimal Interpolation and Kalman  
Filtering"  
May 6 "The Kalman Filter and Smoother (continued)"  
May 8 "The Design of Practical Error Models"  
May 13 "Current Research Topics: The Future Applications".

The Dean of the Division of Applied Sciences is concluding an intensive search for an appointment in Dynamical Oceanography to be made under the URIP. Graduate-student Maryam Golnaraghi started in February 1987 and is working on Regional Data Assimilation Models and Extended General Circulation Models in Embedding.

## 5. FOCUS PROJECT

A Focus Project is a way of focusing the efforts of each of the three components of the URIP on a single activity that combines the need for telemetry, remote sensing and modeling. It ensures that a cooperative effort is maintained between the program elements and helps the individuals working separately on their particular element to stay in touch with each other.

A preliminary consensus has been reached on what a Focus Project might be, but a specific experiment has not yet been defined. The general concept being considered is to collect and telemeter in situ current, temperature and depth data from one or more subsurface moorings located in the western North Atlantic. These data would be used as input or verification for a model of the area and to provide ground truth measurements for remotely sensed sea surface temperature data. It would be attractive to locate these moorings in or near the Gulf Stream because A. Robinson at Harvard is running his Gulf Stream prediction model on a weekly basis. However, it is not clear at this time that the telemetry moorings being developed for use in 1988/89, other than the data capsule approach, are suitable for use in very high current areas.

An attempt may be made to combine URIP field work with the SYNOP program, which has several moored arrays planned for deployment in the Gulf Stream for several years. This interaction will depend on the progress made on the Telemetry Project, the usefulness of the data to the modeling effort, and the SYNOP schedule, as well as the interest and concurrence of N. Hogg and other SYNOP P.I.s with this plan. Tentative planning calls for the Focus Project to begin by Fall 1988.

## 6. NAVY LABORATORY INTERACTION

The following chronology outlines the interaction between P.I.s on the URIP Program and individuals from various Navy laboratories. Since one goal of the URIP Program is to foster such interaction, we have tried to keep track of the substantive contacts. In the future if joint research tasks are undertaken, a more complete discussion of the NAVY/URI interaction will be presented.

DATE	P.I.	NAVY LAB	TOPIC
November 5-7, 1986	P. Rizzoli	INO	Co-chaired session on "Global Prediction Systems" during the Ocean Prediction Workshop 86-Phase II
November 19, 1986	D. Thompson	NORDA	Attended November, 1986 JSC Meeting
February 18, 1987	W. Plant	NRL	Attended February, 1987 JSC Meeting
March 12, 1987	R. Beardsley	INO	Visited INO
March 19, 1987	D. Frye	NORDA	Presented URIP Telemetry Project plans to NORDA oceanographers
March 20, 1987	D. Frye	NAVOCEANO	Presented URIP Telemetry plans to NAVOCEANO engineers
May 7-8, 1987	N. Fofonoff	INO	Presented seminar at INO on "Simple Analogs of Nonlinear Gulf Stream Processes"
May 7-8, 1987	N. Fofonoff	NORDA	Discussed Remote Sensing Initiative with NORDA staff
May 14-27, 1987	A. Robinson, M. Spall, L. Walstadt, S. Glenn	NORDA	Participated in the GI-UK Gap program in Iceland
Weekly	A. Robinson	NAVAL EASTERN OCEANOGRAPHIC CENTER	Weekly interaction concerning Gulf Stream system predictive modeling program

## 7. REFERENCES

- Briscoe, M. G., "Status Report on Ocean Data Telemetry", Woods Hole Oceanographic Institution Technical Report WHOI-86-17, Woods Hole, MA, May 1986.
- Briscoe, M. G. and D. E. Frye, " Motivations and Methods for Ocean Data Telemetry", Marine Technology Society Journal, in press.
- Hibler, W. D., "A Dynamic Thermodynamic Sea Ice Model", Journal of Physical Oceanography, 9, 815, 846, 1979.
- Kraus, E. B. and J. S. Turner, "A One-dimensional Model of the Seasonal Thermocline: II. The General Theory and Its Consequences", Tellus, 19, 98-106, 1967.
- Lemke, P., "A Coupled One-dimensional Sea Ice-ocean Model", Journal of Geophysical Research, in press.
- May, D. R., "NDBC Mooring Design - F-320-14", U.S. Department of Commerce, NOAA, NDBC, NSTL, MS 1986.
- Office of Naval Research and Defense Advanced Research Projects Agency, "Broad Agency Announcement University Research Initiative Program", January, 1986.
- Walden, R. G. and H. O. Berteaux, "Free Drifting RELAYS Buoy Systems", Proceedings 1983 Symposium on Buoy Technology, New Orleans, April, 1983.



## DOCUMENT LIBRARY

November 21, 1986

### *Distribution List for Technical Report Exchange*

Institute of Marine Sciences Library  
University of Alaska  
O'Neill Building  
905 Koyukuk Ave., North  
Fairbanks, AK

Attn: Stella Sanchez-Wade  
Documents Section  
Scripps Institution of Oceanography  
Library, Mail Code C-075C  
La Jolla, CA 92093

Hancock Library of Biology & Oceanography  
Alan Hancock Laboratory  
University of Southern California  
University Park  
Los Angeles, CA 90089-0371

Gifts & Exchanges  
Library  
Bedford Institute of Oceanography  
P.O. Box 1006  
Dartmouth, NS, B2Y 4A2, CANADA

Office of the International  
Ice Patrol  
c/o Coast Guard R & D Center  
Avery Point  
Groton, CT 06340

Library  
Physical Oceanographic Laboratory  
Nova University  
8000 N. Ocean Drive  
Dania, FL 33304

NOAA/EDIS Miami Library Center  
4301 Rickenbacker Causeway  
Miami, FL 33149

Library  
Skidaway Institute of Oceanography  
P.O. Box 13687  
Savannah, GA 31416

Institute of Geophysics  
University of Hawaii  
Library Room 252  
2525 Correa Road  
Honolulu, HI 96822

Library  
Chesapeake Bay Institute  
4800 Atwell Road  
Shady Side, MD 20876

MIT Libraries  
Serial Journal Room 14E-210  
Cambridge, MA 02139

Director, Ralph M. Parsons Laboratory  
Room 48-311  
MIT  
Cambridge, MA 02139

Marine Resources Information Center  
Bldg. E38-320  
MIT  
Cambridge, MA 02139

Library  
Lamont-Doherty Geological Observatory  
Columbia University  
Palisades, NY 10964

Library  
Serials Department  
Oregon State University  
Corvallis, OR 97331

Pell Marine Science Library  
University of Rhode Island  
Narragansett Bay Campus  
Narragansett, RI 02882

Working Collection  
Texas A&M University  
Dept. of Oceanography  
College Station, TX 77843

Library  
Virginia Institute of Marine Science  
Gloucester Point, VA 23062

Fisheries-Oceanography Library  
151 Oceanography Teaching Bldg.  
University of Washington  
Seattle, WA 98195

Library  
R.S.M.A.S.  
University of Miami  
4600 Rickenbacker Causeway  
Miami, FL 33149

Maury Oceanographic Library  
Naval Oceanographic Office  
Bay St. Louis  
NSTL, MS 39522-5001  
ATTN: Code 4601

NO 4181 599

REPORT DOCUMENTATION PAGE	1. REPORT NO. WHOI-87-21	2.	3. Recipient's Accession No.
4. Title and Subtitle Data Telemetry, Assimilation and Ocean Modeling, Semi-Annual Report for the Period October 1, 1986 to April 1, 1987		5. Report Date June 1987	
7. Author(s) Edited by Daniel E. Frye		6.	
9. Performing Organization Name and Address  Woods Hole Oceanographic Institution Woods Hole, Massachusetts 02543		8. Performing Organization Rept. No. WHOI-87-21	
12. Sponsoring Organization Name and Address Office of Naval Research Environmental Sciences Directorate Arlington, VA 22217		10. Project/Task/Work Unit No.  11. Contract(C) or Grant(G) No. (C) N00014-86-K-0751 (G)	
15. Supplementary Notes This report should be cited as: Woods Hole Oceanog. Inst. Tech. Rept., WHOI-87-21.		13. Type of Report & Period Covered Technical 10/1/86 - 4/1/87	
16. Abstract (Limit: 200 words)  The University Research Initiative Program is a cooperative project between Woods Hole Oceanographic Institution, Massachusetts Institute of Technology and Harvard. The objectives of this 5-year Office of Naval Research funded program are to advance the state of the art in ocean data telemetry, interpretation of remotely sensed data from satellite, and numerical modeling of ocean circulation. Ocean data telemetry is being addressed by several development projects whose aim is to reliably transfer data from in situ oceanographic instruments to laboratory computers on the shore. The satellite oceanography group is developing expertise in analyzing, manipulating, displaying and archiving data from all of the major satellite oceanographic sensors. The numerical modeling initiative is working on a family of circulation models which can be connected at their boundaries to cover the important mesoscale and basin wide flow regimes. These ambitious plans are intended to bring new technologies developed in the communications, electronics, satellite sensing and computer science fields into everyday use in oceanography so that they can be ready for the global science programs planned for the 1990's.		14.	
17. Document Analysis a. Descriptors  1. Telemetry 2. Data Assimilation 3. Ocean Modeling 4. Remote Sensing b. Terminology/Open Ended Terms  c. COBATI Field/Group			
18. Availability Statement:  Approved for publication; distribution unlimited.		19. Security Class (This Report) UNCLASSIFIED	21. No. of Pages 33
		20. Security Class (This Page)	22. Price

DATE  
FILMED  
— 88