

2

DTIC FILE COPY

AD-A181 822

NAVAL POSTGRADUATE SCHOOL Monterey, California



DTIC
ELECTE
JUL 06 1987
S D

THESIS

AN ANALYSIS OF THE MODULAR COMMAND AND
CONTROL EVALUATION
STRUCTURE (MCES) APPLICATION TO THE
IDENTIFICATION FRIEND, FOE OR NEUTRAL
(IFFN) JOINT TESTBED

by

Larry W. Moss

March 1987

Thesis Advisor

John T. Malokas, Jr.

Approved for public release; distribution is unlimited.

DISCLAIMER NOTICE

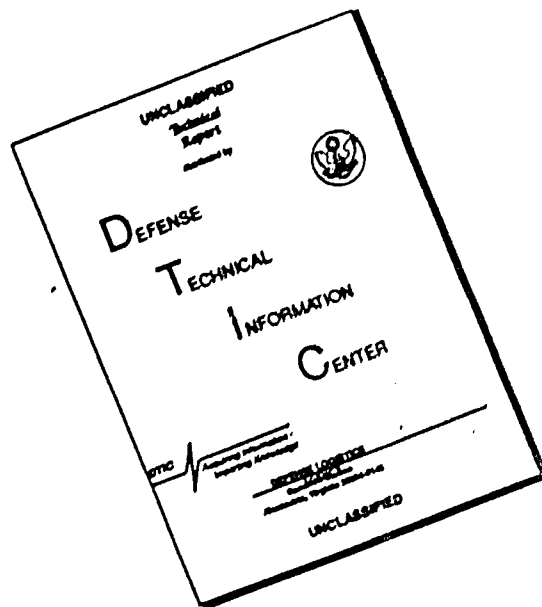

THIS DOCUMENT IS BEST QUALITY AVAILABLE. THE COPY FURNISHED TO DTIC CONTAINED A SIGNIFICANT NUMBER OF PAGES WHICH DO NOT REPRODUCE LEGIBLY.

A10 1001 802

REPORT DOCUMENTATION PAGE

1a REPORT SECURITY CLASSIFICATION UNCLASSIFIED			1b RESTRICTIVE MARKINGS			
2a SECURITY CLASSIFICATION AUTHORITY			3 DISTRIBUTION/AVAILABILITY OF REPORT Approved for public release; distribution is unlimited.			
7b DECLASSIFICATION/DOWNGRADING SCHEDULE			5 MONITORING ORGANIZATION REPORT NUMBER(S)			
4 PERFORMING ORGANIZATION REPORT NUMBER(S)			7a NAME OF MONITORING ORGANIZATION Naval Postgraduate School			
6a NAME OF PERFORMING ORGANIZATION Naval Postgraduate School		6b OFFICE SYMBOL (if applicable) 74		7b ADDRESS (City, State, and ZIP Code) Monterey, California 93943-5000		
6c ADDRESS (City, State, and ZIP Code) Monterey, California 93943-5000			9 PROCUREMENT INSTRUMENT IDENTIFICATION NUMBER			
8a NAME OF FUNDING/SPONSORING ORGANIZATION		8b OFFICE SYMBOL (if applicable)		10 SOURCE OF FUNDING NUMBERS		
8c ADDRESS (City, State, and ZIP Code)			PROGRAM ELEMENT NO	PROJECT NO	TASK NO	WORK UNIT ACCESSION NO
11 TITLE (Include Security Classification) AN ANALYSIS OF THE MODULAR COMMAND AND CONTROL EVALUATION STRUCTURE (MCES) APPLICATION TO THE IDENTIFICATION FRIEND, FOE OR NEUTRAL (IFFN) JOINT TESTBED						
12 PERSONAL AUTHOR(S) Moss, Larry W.						
13a TYPE OF REPORT Master's Thesis		13b TIME COVERED FROM TO		14 DATE OF REPORT (Year, Month, Day) 1987 March		15 PAGE COUNT 86
16 SUPPLEMENTARY NOTATION						
17 COSAT CODES			18 SUBJECT TERMS (Continue on reverse if necessary and identify by block number)			
FIELD	GROUP	SUB-GROUP	Modular Command and Control Evaluation Structure, MCES, Identification Friend, Foe or Neutral Joint Test Force, IFFN, IFFN Joint Testbed, Command and Control			
19 ABSTRACT (Continue on reverse if necessary and identify by block number) <p>This thesis presents an analysis of the application of the Modular Command and Control Evaluation Structure (MCES) to the Identification Friend, Foe, or Neutral (IFFN) Joint Testbed. The MCES and IFFN Testbed evaluation approaches are also compared. MCES is a structured approach to evaluate Command and Control (C2) systems which uses standard and evolving operational research tools. The MCES approach provided the IFFN Joint Testbed with an air defense C2 system architecture which became a descriptive tool for C2 analysts to define and evaluate measures to determine the effectiveness of competing air defense C2 systems. This IFFN application served as an evaluation and refinement of MCES as well as a tool for assisting the IFFN Joint Test Force in evaluating U.S. air defense C2 systems in the NATO area.</p>						
20 DISTRIBUTION AVAILABILITY OF ABSTRACT <input checked="" type="checkbox"/> UNCLASSIFIED/LIMITED <input type="checkbox"/> SAME AS RPT <input type="checkbox"/> DTIC USERS				21 ABSTRACT SECURITY CLASSIFICATION Unclassified		
22a NAME OF RESPONSIBLE INDIVIDUAL John T. Malokas, Jr.				22b TELEPHONE (Include Area Code) (408) 646-2772		22c OFFICE SYMBOL 74

Approved for public release; distribution is unlimited.

An Analysis of the Modular Command and Control Evaluation
Structure (MCES) Application to the
Identification Friend, Foe or Neutral (IFFN) Joint Testbed

by

Larry W. Moss
Captain, United States Army
B.S., University of Houston, 1976

Submitted in partial fulfillment of the
requirements for the degree of

MASTER OF SCIENCE IN SYSTEMS TECHNOLOGY
(Command, Control and Communications)

from the

NAVAL POSTGRADUATE SCHOOL
March 1987

Author:

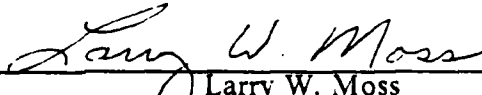

Larry W. Moss

Approved by:

John T. Malokas, Jr., Thesis Advisor

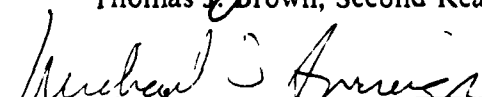
Thomas J. Brown, Second Reader

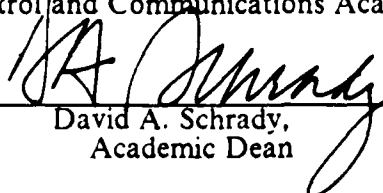
Michael G. Sovereign, Chairman,
Command, Control and Communications Academic Group

David A. Schrady,
Academic Dean

ABSTRACT

This thesis presents an analysis of the application of the Modular Command and Control Evaluation Structure (MCES) to the Identification Friend, Foe, or Neutral (IFFN) Joint Testbed. The MCES and IFFN Testbed evaluation approaches are also compared. MCES is a structured approach to evaluate Command and Control (C2) systems which uses standard and evolving operational research tools. The MCES approach provided the IFFN Joint Testbed with an air defense C2 system architecture which became a descriptive tool for C2 analysts to define and evaluate measures to determine the effectiveness of competing air defense C2 systems. This IFFN application served as an evaluation and refinement of MCES as well as a tool for assisting the IFFN Joint Test Force in evaluating U.S. air defense C2 systems in the NATO area.



Accession For	
NTIS CRA&I	<input checked="" type="checkbox"/>
DTIC TAB	<input type="checkbox"/>
Unannounced	<input type="checkbox"/>
Justification	
By	
DTIC number	
Availability Codes	
DAI	Availability Codes
A-1	

TABLE OF CONTENTS

I.	INTRODUCTION	10
A.	NATURE OF THE PROBLEM	10
B.	MCES METHODOLOGY	10
C.	MCES EVOLUTION	12
D.	IFFN BACKGROUND	12
E.	MCES APPLICATION TO THE IFFN TESTBED	13
F.	THESIS ORGANIZATION	14
II.	MCES METHODOLOGY DESCRIPTION	15
A.	INTRODUCTION	15
B.	MCES MODULES	15
1.	Module 1: Problem Formulation	15
2.	Module 2: C ² System Bounding	15
3.	Module 3: C ² Process Definition	16
4.	Module 4: Integration of System Elements and Functions	20
5.	Module 5: Specification of Measures	22
6.	Module 6: Data Generation	22
7.	Module 7: Aggregation of Measures	23
C.	COURSES OF ACTION	25
D.	USES	26
III.	IFFN TESTBED DESCRIPTION	28
A.	THE IDENTIFICATION PROBLEM	28
B.	THE AIR DEFENSE PROCESS	29
C.	IFFN JOINT TESTBED CONCEPT	30
1.	Baseline Architecture	31
2.	Major Operational Issues	32
3.	Hybrid Approach	33
4.	Models	34

D.	TESTBED PHASES	35
1.	Test Series 1	35
2.	Test Series 2	35
3.	Test Series 3	35
4.	Test Series 4	35
5.	Test Series 5	35
6.	Test Series 6	36
7.	Test Series 7	36
E.	IFFN TEST CELL MATRIX	37
F.	MEASURES	37
1.	Test Series 2 Objectives	38
2.	Measures of Effectiveness (MOE)	40
3.	Measures of Performance (MOP)	40
4.	Measures of Force Effectiveness (MOFE)	40
G.	ANALYSIS OF DATA	43
1.	Exploratory Data Screening	43
2.	Data Analysis	44
H.	IFFN PROGRESS SUMMARY	45
IV.	PROPOSED MCES APPLICATION TO THE IFFN TESTBED	46
A.	INTRODUCTION	46
B.	PROBLEM FORMULATION	46
C.	C ² SYSTEM BOUNDING	48
D.	C ² PROCESS DEFINITION	48
1.	Air Defense C ² Process Functions	48
2.	Distributed C ² Process Interface	49
E.	INTEGRATION OF SYSTEM ELEMENTS AND FUNCTIONS	53
1.	Structures	55
2.	Architecture	59
F.	SPECIFICATIONS OF MEASURES	62
1.	MCES Test Series 2 Issues	63
2.	MCES Measures	63
G.	MCES APPLICATION SUMMARY	65

V.	ANALYSIS OF THE IFFN TESTBED AND MCES APPROACHES	67
A.	FEEDBACK TO THE DECISION-MAKER	67
B.	PROBLEM FORMULATION	67
C.	C ² SYSTEM BOUNDING	68
D.	C ² PROCESS DEFINITION	68
E.	SYSTEM ELEMENTS AND FUNCTIONS	68
F.	SPECIFICATION OF MEASURES	69
	1. Deriving Measures	69
	2. MOEs versus MOPs	70
	3. Functional Measures	71
	4. Distributed Functions and Measures	72
	5. Operational versus Design/Qualitative Measures	73
	6. Resource Conservation and Reallocation Measures	74
G.	DATA GENERATION AND TESTBED DESIGN	75
H.	OVERLAPPING OF PROCEDURES AND TOOLS	76
	1. Problem Formulation and Bounding	76
	2. Functional Analysis	77
	3. Model or Architecture Building	77
	4. IFFN and MCES Measure Specification	77
I.	COMPARISON SUMMARY	78
VI.	CONCLUSIONS AND RECOMMENDATIONS	79
A.	IFFN CONCLUSIONS	79
B.	IFFN RECOMMENDATIONS	79
C.	MCES APPLICATION CONCLUSIONS	80
	1. Integration of System Elements and Functions Module	80
	2. Distributed C ² Process Functions	80
	3. Solid Evaluation Tool	81
	4. MCES Application to Additional IFFN Testbed Test Series	81
D.	MCES RECOMMENDATIONS	81
	1. Continued MCES Application to the IFFN Testbed	81
	2. Further MCES Testing and Refinement	81
	3. Integration of More C ² Evaluation Tools	81

4. Standard MCES Terminology and Definitions	82
5. Education and Dissemination	82
LIST OF REFERENCES	83
INITIAL DISTRIBUTION LIST	85

LIST OF TABLES

1. CRITERIA FOR EVALUATION MEASURES	24
2. MOE DEFINITIONS	41
3. MOP DEFINITIONS	42
4. MCES FUNCTIONS AND MEASURES	71
5. DISTRIBUTED FUNCTIONS AND MOPS	72
6. C2 MEASURES FOR AIR DEFENSE	74

LIST OF FIGURES

1.1	MCES Modules	11
2.1	Module 1, Problem Formulation	16
2.2	Module 2, C ² System Bounding	17
2.3	Module 3, C ² Process Definition	19
2.4	Module 4, Integration of System Elements and Functions	21
2.5	Module 5, Specification of Measures	23
2.6	Module 6, Data Generation	25
2.7	Module 7, Aggregation of Measures and Interpretation	26
2.8	MCES Modules and Output	27
3.1	IFFN Air Defense Structure	32
3.2	IFFN Basic Test Matrix	38
3.3	IFFN Test Design Approach	39
4.1	IFFN Application of MCES Module 1	47
4.2	IFFN Application of MCES Module 2	49
4.3	IFFN Air Defense C ² Process Functions	50
4.4	Mapping of Air Defense C ² Functions	50
4.5	XTELL Process Functions and C ² Process Interface	52
4.6	Lateral XTELL Process	53
4.7	INTELL, XTELL, and C ² Process Interface	54
4.8	IFFN Application of MCES Module 3	54
4.9	Air Defense Single Node Data Flow Diagram	56
4.10	Centralized Control of a Battalion Fire Unit	59
4.11	Decentralized Control of a Battalion Fire Unit	60
4.12	IFFN Application of MCES Module 4	62
4.13	MCES Approach for Determining Measures	64
4.14	IFFN Application of MCES Module 5	65

I. INTRODUCTION

A. NATURE OF THE PROBLEM

How much of a force multiplier can be attributed to a particular command and control (C^2) systems? Given several alternative C^2 systems, which is best? What has to be measured to determine this difference? Are all the relevant factors taken into account? These are complex C^2 questions being asked by the Joint Chiefs of Staff as well as other senior military commanders as they are faced with acquiring, testing, and operating C^2 systems.

A methodology is needed to describe the C^2 systems architecture which will allow analysts to measure C^2 systems response and attribute the effectiveness of that response to the elements or structural relationships which form that C^2 system. There is a definite need for generic tools to evaluate C^2 systems and architectures. What was lacking in current C^2 evaluation methodologies was a method to relate C^2 systems to measures of its contribution to force effectiveness and mission accomplishment. In the past, C^2 evaluation has been conducted in a piecemeal fashion with assorted evaluation tools only for specific parts of the problem. The Joint Chiefs of Staff Command, Control and Communications Systems Directorate's (JCS C3S) recognized these needs and required development of a paradigm to evaluate competing C^2 architectures [Ref. 1: p. 8]. The Modular Command and Control Evaluation Structure (MCES) attempts to address this need.

B. MCES METHODOLOGY

MCES was developed as a structured approach to evaluate C^2 systems and uses standard and evolving operations research tools. MCES attempts to integrate the previous efforts of C^2 users and analytic organizations to form a single C^2 evaluation package.

The MCES is composed of seven separate modules which guide analysts through the command and control evaluation. Figure 1.1 represents the seven modules of the MCES methodology and the output from each module. The first module is used by the analyst and operational user to define the particular C^2 problem. The next three modules set the terminology and theory to describe the C^2 system architecture which permits analysts to model the C^2 system and its operation. Inherent in the

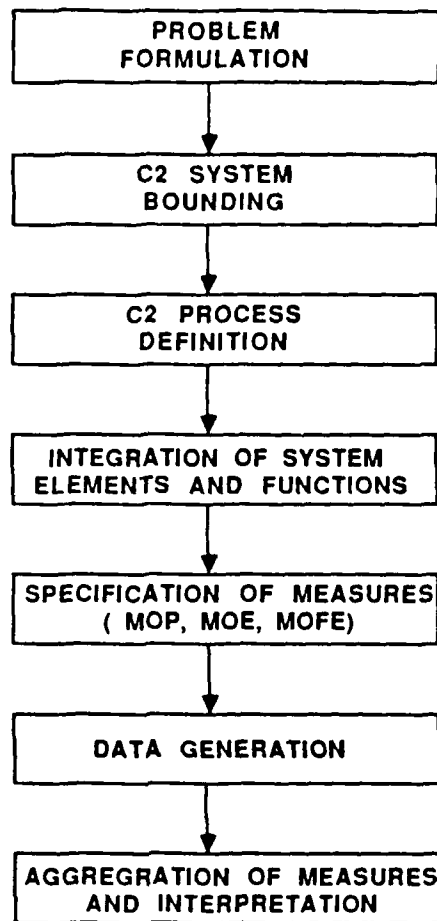

Figure 1.1 MCES Modules.

methodology is a need to describe the C^2 system as an architecture integrating physical elements and process functions into a structural framework. MCES shares common terminology of current C^2 systems evaluation methodologies. The MCES defines "architecture" as a description of an integrated set of systems whose physical entities, structure and functions are coherently related. The architecture provides a representation which will eventually lead to the ability to measure the C^2 system response and the effectiveness of directing forces to accomplish the mission. The C^2 theory behind these modules is robust enough to allow analysts to reconfigure the particular C^2 system physically or structurally within the architecture during the C^2 evaluation. In module 5, measures are developed which will be used to discriminate between alternative configurations of the architecture. When the measures for the C^2

system have been identified, the sixth module requires that a suitable data generator be selected or developed to derive the values for the measures selected. The final MCES module is used to aggregate and evaluate the C^2 measure results in order to determine the optimal C^2 system for a particular mission. [Ref. 1: pp. 10-23]

C. MCES EVOLUTION

The Modular Command and Control Evaluation Structure (MCES) was developed at the Naval Postgraduate School with research support from the Military Operations Research Society (MORS) and monetary support from different military agencies [Ref. 2: p. 13]. The MCES development started with military community research and discussion concerning the need to develop and quantify measures of effectiveness appropriate to C^2 systems. According to the MCES principal investigator, Dr. Ricki Sweet, MCES is evolving as any scientific development in the following steps [Ref. 1: p. 31]:

1. Public discussion and mandate for clarification;
2. Setting up the nature of the problem, the tools, definitions, and potential directions;
3. First order development of the identified components;
4. Specification of the interrelationships of the components;
5. Testing of the theory with real problems, i.e., extra-laboratory experiments; and
6. Refining the structure in accordance with the test results.

The MCES methodology is evolving in order to resolve key C^2 issues. Throughout this evolution, C^2 tools and models have been identified, developed, and integrated into the MCES. Having completed the first cycle of the referenced six steps of scientific development, MCES is now in the process of a continuing iteration of the last two steps of test and refinement. The Identification Friend, Foe or Neutral (IFFN) Joint Testbed application is an example of such a MCES test and refinement iteration. This scientific development will lead to a further refined, bounded and generic methodology that may fulfill many C^2 architecture evaluation requirements.

D. IFFN BACKGROUND

The IFFN testbed is currently addressing the air identification problem, which is a subset of the overall air defense C^2 problem. The testbed is representative of the NATO air defense C^2 system which must operate in an environment of friendly, enemy and neutral aircraft to perform its air defense mission. Within the air defense C^2

architecture. geographically separated radars and special intelligence sources develop detection, track, and identification information on air objects. Computers are then used to store and correlate this information. Digital communications are then used to share the track information between command facilities. The command organizations develop perceptions of the battle situation and make decisions to achieve mission goals based on these perceptions. The command organization then implements the decisions by directing and controlling air defense forces to take some action against the enemy forces. The test concept uses a computer simulation of manned and simulated command centers and weapon systems employing real world operating procedures against varied threat scenarios. [Ref. 3: pp. 3-5]

The IFFN C² system bounds were defined by geographic areas of responsibility within the NATO Fourth Allied Tactical Air Force (4ATAF) sector. The specific command centers that perform the C² functions are: Sector Operations Centers (SOC), Control and Reporting Centers (CRC), Brigade Fire Direction Centers (Bde FDC), and Battalion Fire Direction Centers (Bn FDC). Information sources considered to be within the C² system are: NATO Airborne Early Warning systems (NAEW), Special Information (intelligence) Systems (SIS), and other information sources (i.e., flight plans). The air defense C² system architecture included the weapon systems when they performed C² functions. The air defense weapon systems considered by the IFFN testbed are the F-15, all weather fighter, and the HAWK and PATRIOT surface-to-air missiles (SAMS).

E. MCES APPLICATION TO THE IFFN TESTBED

A MORS workshop team specifically researched the IFFN problem during a conference to assist the IFFN Testbed in finding a solution to the IFFN problem. The initial C² problem statement formulated by the January 1985 MORS Workshop from the original IFFN Testbed issues was:

How effective is the Central Europe air defense C2 system in providing decision makers the means to assess the situation and employ air defense assets in order to meet overall mission objectives? [Ref. 4: p. 1]

During the 1985 MORS C² Evaluation Workshop, the IFFN Test Director, Colonel Dave Archino issued the following challenge to the working group:

Develop a tool . . . specific to air defense that allows IFFN to evaluate the flow of C2 information throughout the C2 structure and determine if it is useful or not in winning the war . . . meeting the mission objectives . . . and operational issues IFFN plans to address. [Ref. 4: p. 1]

It was determined that MCES could be tailored to help solve the IFFN testbed requirements. Major Patrick Gandee, while a Naval Postgraduate School student, was the principal investigator of the MCES application to the IFFN Testbed.

F. THESIS ORGANIZATION

This thesis will summarize how the MCES was specifically applied to the air defense problem and how that application has been used by the IFFN testbed to address their operational issues. A comparison of the IFFN Testbed and MCES approaches will be presented. Since MCES was concurrently evaluated and refined in the IFFN application process, this thesis will continue the evolution process by formulating recommendations for further MCES refinement.

The MCES methodology will be outlined in Chapter II. The IFFN Testbed and its evaluation approach will be described in Chapter III. Chapter IV will describe the application of MCES to the IFFN Testbed. A discussion of the differences between the MCES and IFFN Testbed approach is presented in Chapter V. Conclusions and recommendations concerning both the IFFN Testbed and the MCES methodology are presented in Chapter VI.

II. MCES METHODOLOGY DESCRIPTION

A. INTRODUCTION

The following description of MCES is taken in part from Dr. Sweet's report on MCES [Ref. 1: pp. 10-23] and from her notes and briefings. The figures presented in this chapter are revised and updated versions of the ones she used in her publications and briefings. A more detailed description and analysis of MCES will be presented in Chapter IV when the MCES application to the IFFN testbed is used as an example.

B. MCES MODULES

MCES is divided into seven modules which are detailed below by module.

1. Module 1: Problem Formulation

In module 1, the decision-maker's analysis objectives and needs are described for a specific C^2 problem. First, the decisionmaker's needs are characterized. The analysts consider the decisions being formulated, assumptions about the problem, the level of analysis required, and the mission supported. Both the appropriate scenarios and assumptions underlying the evaluation are made explicit and the required level of analysis is determined. This problem statement is then used in the second module to bound the C^2 system of interest. The implementation of this module results in a more precise statement of the problem and analysis objectives. Figure 2.1 lists the major actions required in module 1. [Ref. 1: pp. 10-11]

2. Module 2: C^2 System Bounding

Module 2 identifies the relevant system elements that will bound the system. When bounding the C^2 system, a three component definition of a C^2 system is used based on *JCS Publication 1* [Ref. 5: p. 77]. These definitions state that a C^2 system consists of physical entities, structures, and C^2 processes. Physical entities are equipment, software, people and their associated facilities. Structure includes organization, procedures, protocols, concepts of operation and information flow patterns. The term " C^2 process" refers to what the system is doing or the functions that the process performs. Bounding the system requires bounding of the physical entities and structure. The C^2 processes are developed in Module 3.

There are two issues that are raised in this module. The first issue is the mapping of C^2 system physical components and personnel to the systems boundaries.

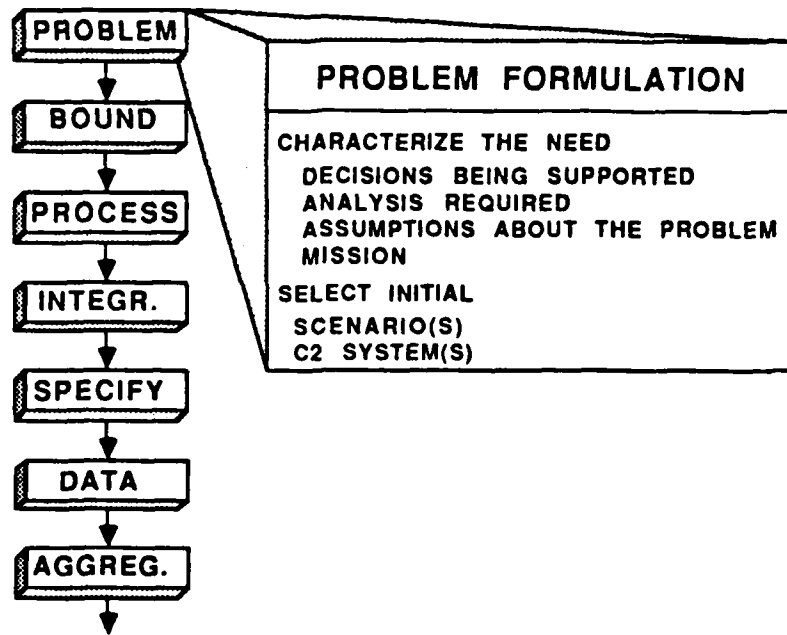

Figure 2.1 Module 1, Problem Formulation.

The second issue concerns determining the required levels of analysis. One method of graphically illustrating this process of bounding the environment is through the use of Dr. Sweet's "onion" as a representative of the environment. The insert of Figure 2.2 displays this representation. Starting in the middle of the onion are the subsystems of the C^2 system. Going out from the middle, the C^2 subsystems constitute the C^2 system. The C^2 system is itself a component of the overall force which in turn is a part of the environment. The area outside of the "Onion Skin" is the rest of the world. Successive "peeling" of the "onion skin" will reveal the C^2 subsystems to be evaluated. Module 2 results in the bounding of the problem and the identification and categorization of the system elements of physical entities and organizational structure. Figure 2.2 depicts the activities for Module 2. [Ref. 1: pp. 12-13]

3. Module 3: C^2 Process Definition

Module 3 defines the processes needed to fulfill the C^2 mission. The particular command and control process is described by analyzing the generic C^2 processes of the system. The proposed MCES solution to understanding the C^2 processes of a particular C^2 system is to use an information based paradigm similar to the J. Lawson C^2 Process Model [Ref. 6: pp. 93-99] in the broader framework of MCES. The insert of Figure 2.3 displays a modified Lawson's generic C^2 process loop

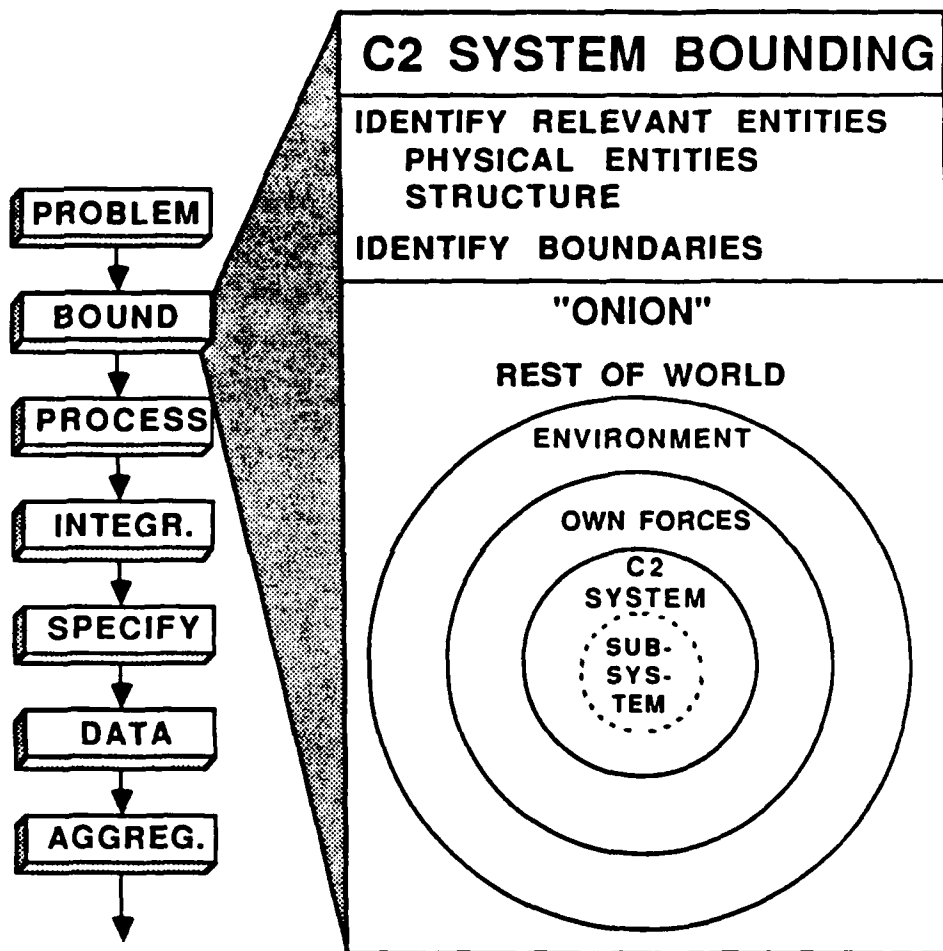

Figure 2.2 Module 2, C² System Bounding.

model. One example of Lawson's generic C^2 loop model components is the ASSESS block. The assessments for human decisions are made by battle commanders performing the ASSESS function. The commanders' assessments are made by perceiving and assigning meaning to the overall situation. Commanders use information from their own sensors, feedback from their forces, and an interface with a separate intelligence process to develop these perceptions about the enemy and friendly capabilities. The other functions of Lawson's generic C^2 process model are performed in most C^2 processes. [Ref. 1: p. 14]

It is necessary to provide a translation of the vocabulary of the C^2 problem into the terminology of the generic C^2 process model to effectively use MCES. This translation of terms helps the analyst keep from overlooking critical processes and provides standard vocabulary and definitions. In the past, MCES has been able to apply the generic C^2 process model successfully with only minor modifications. There are different C^2 process levels and interactions among the C^2 process function components and these process relationships can become very complex. To illustrate different levels of processes, an example of a commander performing a decision function can be used. The commander passes his decision to several subordinates who in turn work out detailed instructions to implement that decision. These subordinates communicate the instructions to their forces which then act in the environment. In command and control terms, the commander and the subordinates were performing separate decision functions within a C^2 process. The subordinates' decision function is related to the commander's decision function by the commander's decision (output) and the subordinates' receipt (input). In turn, the detailed instructions from the subordinates to the force couple the subordinate's function to the force function. This functional input/output relationship forms a "structure" between separate C^2 process functions which are required to perform the mission. The structure determines the information flow. [Ref. 1: p. 15]

In a distributed C^2 system, processes may be related to other processes. The processes that have been valuable to MCES C^2 evaluations for describing distributed information flow are [Ref. 1: pp. 70-73]:

1. Intelligence (INTELL) Process. Assigns meaning to observed activities and situations and forecasts changes in the current situation.
2. Crosstell (XTELL) Process. A subset of the communications process, which provides for sharing of information throughout the C^2 system to support decisions and their implementation.
3. Execution Level C^2 Process. Directly controls weapon systems.

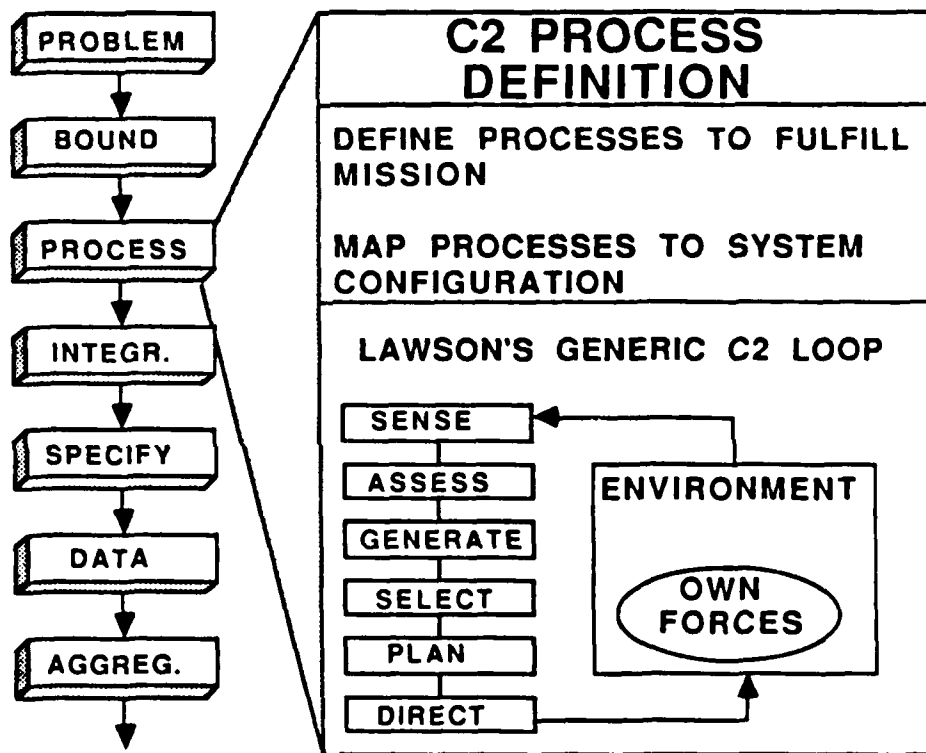

Figure 2.3 Module 3, C² Process Definition.

A complete picture of the C^2 systems architecture includes the intelligence process and how it interfaces with the C^2 process. XTELL is the sharing of information and is needed to describe the coordination between distributed C^2 systems. At a single command node, XTELL is simply a process function but on a systems level it is a networking process. At a single node, the C^2 process directly controls weapon systems. At a higher level, the C^2 process coordinates the directing of the weapon systems. These processes are dynamic descriptions of what the C^2 system is doing. XTELL and INTELL processes interfaced with the C^2 process in a distributed system are ultimately linked to the weapon systems which perform the mission.

Dr. Sweet emphasizes that this module forces the analysts attention on [Ref. 1: p. 14]:

1. the environmental cause or initiator (i.e., the enemy force) of the C^2 process that results from a change in the desired state;
2. the internal C^2 process functions that characterize what the system is doing such as sense, assess, generate, select, plan, and direct; and
3. the input and output from the internal C^2 process that couples with the force process

Figure 2.3 represents the major actions required in module 3. As a result of the implementation of this module, the functions of the C^2 process for a given problem are identified and mapped to the generic C^2 process loop.

4. Module 4: Integration of System Elements and Functions

Module 4 relates the information flow to a C^2 system by means of its C^2 process functions. Functions are subsets of the C^2 process and represent what the C^2 system actually does or accomplishes. The relationship of the C^2 physical entities to the process functions and organizational structure is also formulated in this module. This integration is accomplished by making explicit the relationships between these components. Figure 2.4 outlines the actions required in Module 4.

The first step is to map the physical entities of man and machine which perform the functions and produce output to an organizational structure. All C^2 functions can be potentially performed in a single node or be distributed between different nodes so this mapping results in an organizational structure which graphically depicts a single node or a distribution of command and weapon nodes depending on the system's unique configuration.

Next, the flow of information is charted by techniques such as Data Flow diagrams (DFDs) [Ref. 7: pp.99-115] or Petri Nets [Ref. 8] which may be used to

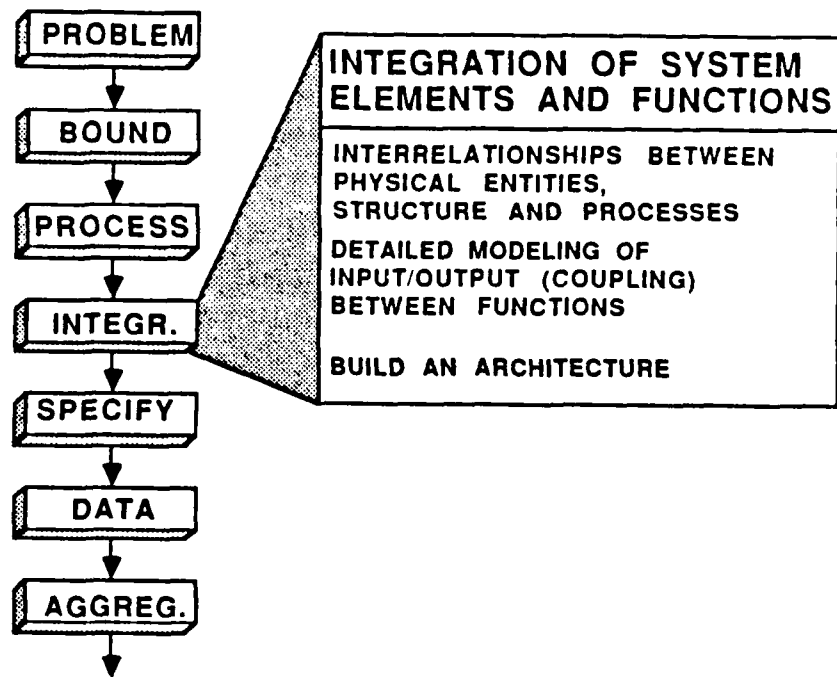

Figure 2.4 Module 4, Integration of System Elements and Functions.

describe information flow through the C^2 process model. DFDs and Petri Nets will be discussed in greater detail in Chapters V and VI. DFDs are an example of a technique that has been productive in this module in determining relationships between processes and information flow. Data Flow Diagrams (DFDs) are first constructed to show information flow through the C^2 process model. The inputs and outputs of each function are determined and related to the other functions in the process. In the next step, a transform analysis is performed to uncover the transform center (process center) and to determine the subordinate and superordinate relationships between the transform center and the individual C^2 functions. Information flows into the transform center and control information flows out of the transform center. These input output relationships describe the internal information flow between separate process functions. The data flowing into the transform center or process center is information flow while the data flow out of the transform center is control information flow in the form of action requests or commands. Thus a hierarchical "structure" has been defined in terms of the mission essential information flow between functions

within the C^2 process. From this information, a C^2 system architecture will eventually be formulated. These procedures will result in the description of how the elements and players function together, which is basically relating information flow to organizational structure. [Ref. 1: pp. 16-17]

5. Module 5: Specification of Measures

Module 5 specifies the measures necessary to evaluate the C^2 problem. These measures are then classified as to their level of measurement, i.e., dimensional parameters, measures of performance (MOPs), measures of effectiveness (MOEs), or measures of force effectiveness (MOFEs). MOFEs are used to describe the actions between the force and the environment. When the C^2 system is combined with the force, the environment will be effected and MOFEs measure this force effect. Within the force boundary, MOEs are used to measure how the combat force is effected by the C^2 operation. MOPs are applied at the C^2 system boundary and measure how well the C^2 system performs its functions. For the subsystem within the boundary of the C^2 system, dimensional parameters are used to measure the limits of the subsystems. The resulting measures may be used to determine differences in a C^2 system when utilizing alternative configurations of the physical entities, structure, or processes. Figure 2.5 graphically depicts the "onion" with its corresponding measures and the actions required in Module 5.

This MCES implementation results in the specification of a set of measures focused primarily on the process functions. The process functions identified may be used to derive a complete set of relevant measures which can then be subjected to further scrutiny. A set of measures can be compared to a set of desired measures characteristics as shown in Table 1 [Ref. 1: p. 20] to insure that the measures are useable.

6. Module 6: Data Generation

In Module 5, one of several types of data generators such as exercises, experiments, simulations, subjective judgements, or relevant experiences is selected to generate the necessary values for the measures formulated. These values may be either measured directly or indirectly. The analysts consider the reproducibility of results, precision and accuracy, timing of collection, environmental controls, and experimental design during this module. A timeline is formulated to set the completion dates for the data generation phases. Using the designated data generator, the resulting values for these measures constitute the output of this module. Figure 2.6 outlines the data generation module. [Ref. 1: p. 21]

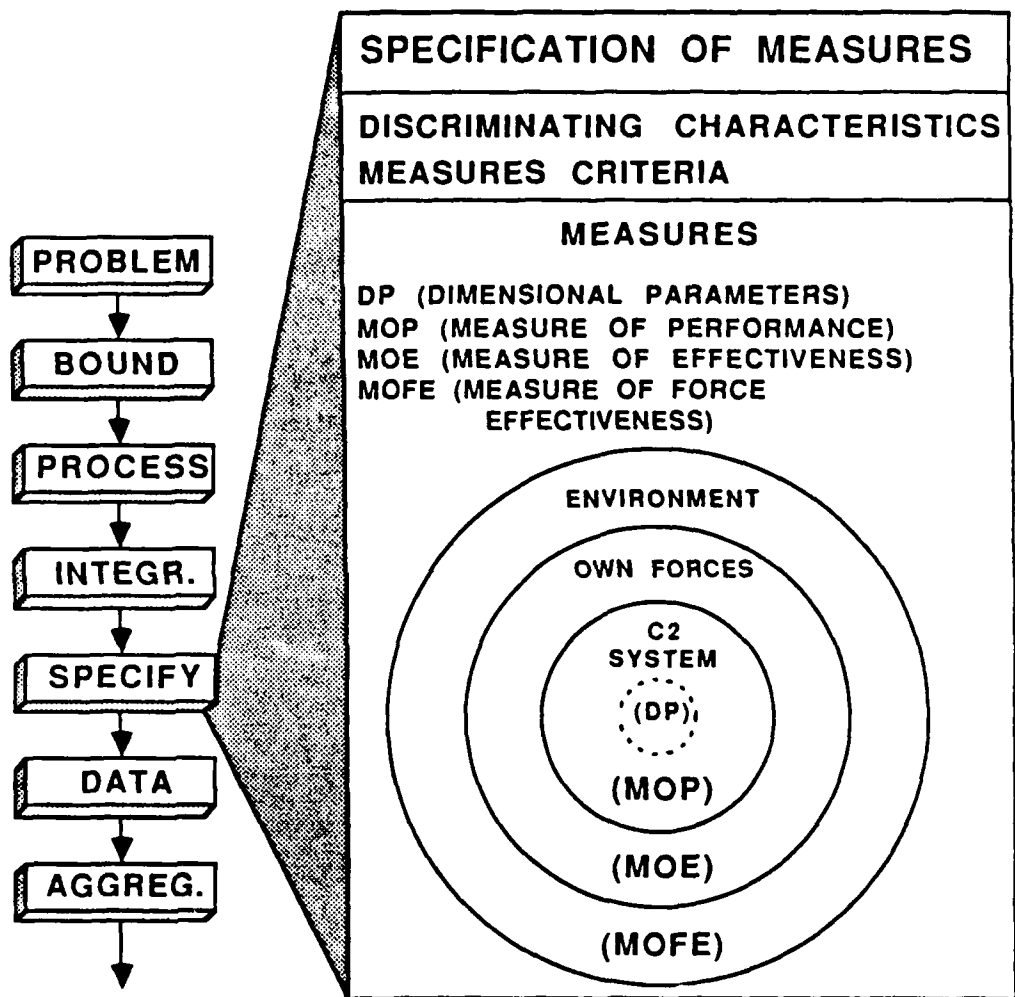

Figure 2.5 Module 5, Specification of Measures.

TABLE 1
CRITERIA FOR EVALUATION MEASURES

CHARACTERISTICS	DEFINITION
Mission oriented	Relates to force/system mission.
Discriminatory	Identifies real difference between alternatives.
Measurable	Can be computed or estimated.
Quantitative	Can be assigned numbers or ranked.
Realistic	Relates realistically to the C ² system and associated uncertainties.
Objective	Can be defined or derived, independent of subjective opinion.
Appropriate	Relates to acceptable standards and analysis objectives.
Sensitive	Reflects changes in system variables.
Inclusive	Reflects those standards required by the analysis objectives.
Independent	Is mutually exclusive with respect to other measures.
Simple	Is easily understood by the user.

7. Module 7: Aggregation of Measures

Module 7 is the final module and addresses the issue of the aggregation and interpretation of the observed values of the measures. Figure 2.7 depicts the aggregation and interpretation process. From data generation, values for the identified measures will be obtained and analyzed. One of the analysts' concerns will be to relate command and control systems to some measure of force effectiveness which is sometimes termed the force multiplier effect. For MOFEs, the intent of aggregation is to relate the C² system with combat systems to indicate combat outcomes. After aggregation, the issues of measure causality, sufficiency, and independence are to be considered. Scenario dependence must also be addressed. Because combat is very complex, many measures will not show significant differences. Analysis must be conducted to determine the important factors in the particular scenarios. At this

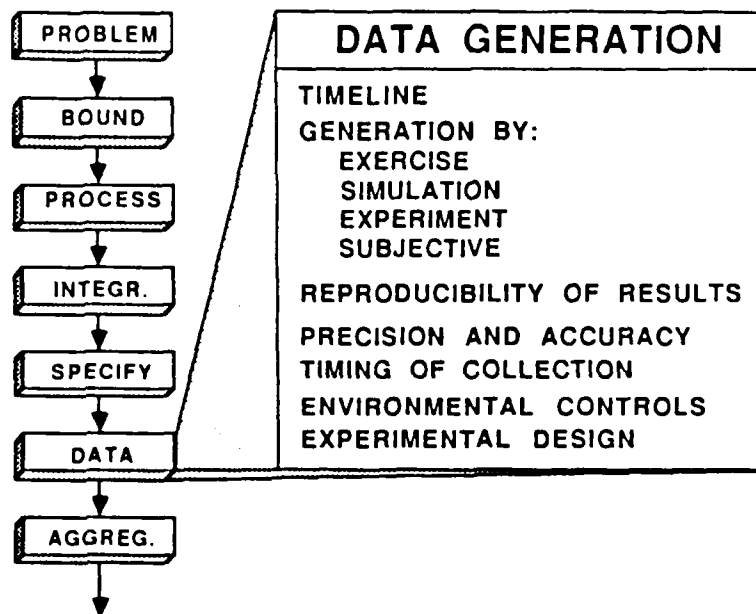

Figure 2.6 Module 6, Data Generation.

crucial point, the analysts must decide if their questions can be answered by their analysis. Credibility and reliability are major concerns to the decisionmakers. [Ref. 1: pp. 21,22]

C. COURSES OF ACTION

The results of the MCES iteration are provided to the decisionmaker. Figure 2.8 represents the actions and results of each iteration of the MCES modules. At least two courses of action are then available to the decisionmaker based on the results. The decisionmaker may directly implement the results of the MCES evaluation or he may identify the need for further study or require another iteration of the MCES analysis. The decisionmaker may interact with the MCES analysis effort to further guide the analysts by identifying errors in assumptions, clarifying the bounding, etc. The analysis could be modified by infusing new directions or objectives based upon the results of previous MCES modules completed. For example, the bounding of the C^2 system may generate the observation that significant interfaces are outside the originally conceived scope of the study and require a return to the problem formulation module.

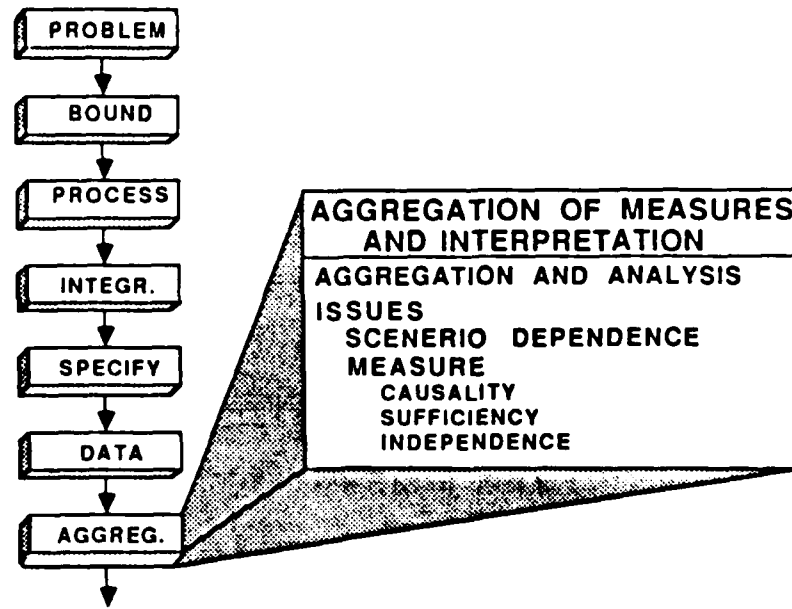

Figure 2.7 Module 7, Aggregation of Measures and Interpretation.

D. USES

MCES can assist in the areas of C^2 management and analysis. MCES assists in the systematic specification of the problem by focusing on identified essential characteristics of the C^2 system. It permits a senior analyst to conduct a C^2 evaluation effectively. MCES assists the analyst in forming a concise conclusion and provides the manager with supporting data for decisionmaking. The ITN Testbed is a good example of a C^2 evaluation of air defense and will be illustrated in the following chapters.

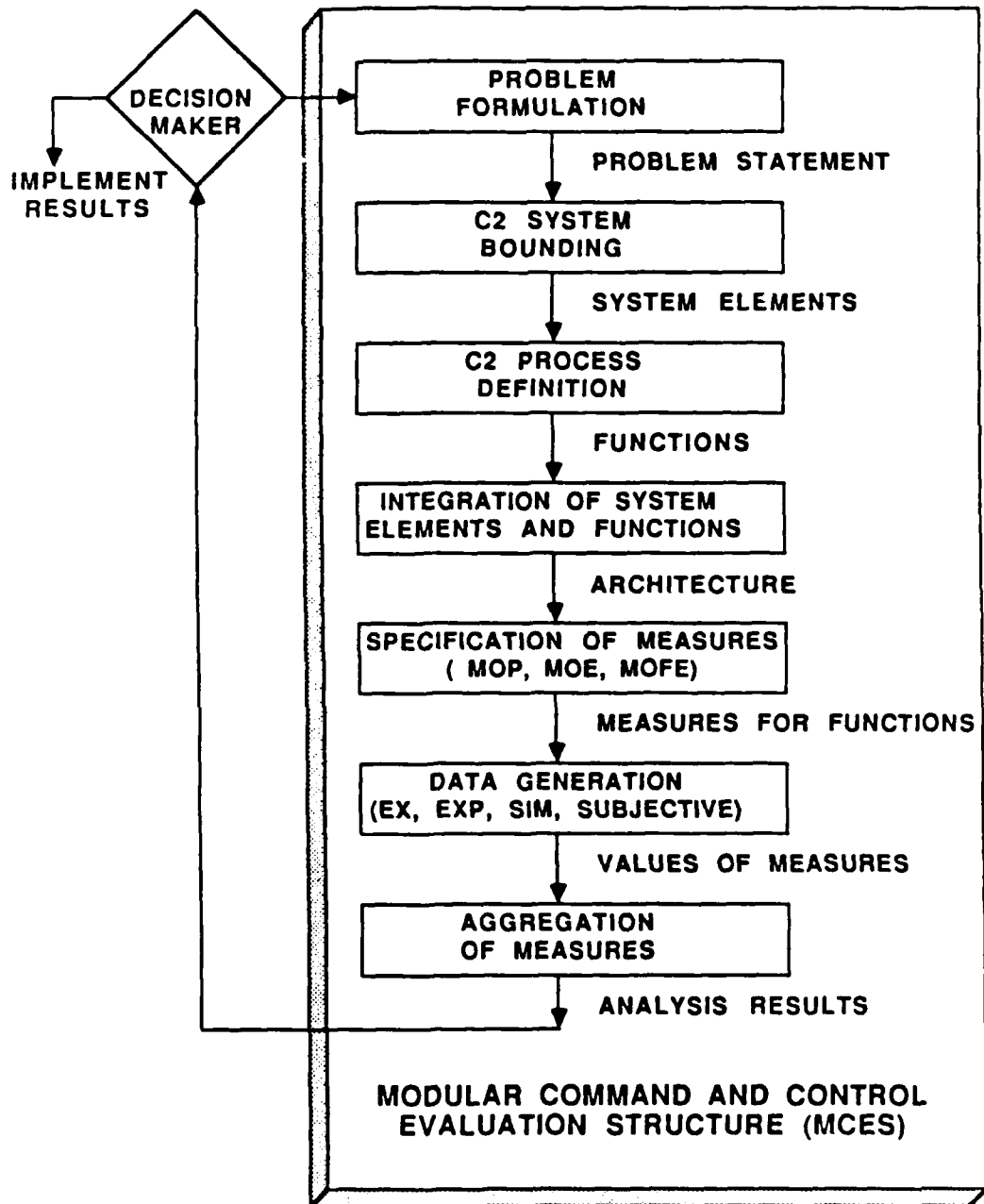

Figure 2.8 MCES Modules and Output.

III. IFFN TESTBED DESCRIPTION

A. THE IDENTIFICATION PROBLEM

The Identification Friend, Foe or Neutral (IFFN) Testbed, comprised of a U.S. Army and Air Force Joint Test Force at Kirtland Air Force Base, is investigating ways to enhance the identification of friendly, neutral, and enemy aircraft. A realistic scenario used by the IFFN Joint Test Force forecasts that in future air battles our tactical air defenses will be faced with sophisticated enemy fighters capable of engaging our forces with beyond visual range (BVR) weapons. The large number of enemy aircraft with their use of low level tactics, high speeds, and Electronic Countermeasures (ECM) challenges our air defense systems. The air defense system must be able to identify and characterize the enemy attack and then direct sufficient force in time to neutralize it. [Ref. 9: p. 47]

Effective performance of the active air defense mission requires a capability to correctly identify aircraft in a timely manner in order to facilitate the air defense weapon system's ability to employ its weapons. This air defense process is done through a complex arrangement of personnel, equipment, communications facilities and procedures which form a C^2 system. This requirement is particularly important in the European theater where large numbers of friendly, neutral, and enemy aircraft will be part of the tactical air environment. In this environment, surface-to-air and air-to-air weapon systems must operate in conditions beyond ranges where positive visual identification can not be performed. The problem is aggravated when modern electronic warfare (EW) threats, particularly those of the Warsaw Pact are considered. Numerous studies have revealed that current electronic identification capabilities have numerous problems including being too slow, poor at positively identifying enemies and friends, insufficient range capability, and being subject to interference and electronic countermeasures (ECM). The inability of air defense weapon systems operators to accurately and rapidly discriminate friend, foe, or neutral aircraft results in the ineffective use of these weapon systems. These problems have stimulated activity within the US military and NATO to develop an effective NATO identification system. The IFFN Testbed is a partial attempt by the United States at solving this air defense problem. [Ref. 3: p. 1]

The function of acquiring, correlating, fusing, and disseminating direct and indirect IFFN information is an important part of air defense C². This IFFN information serves as a basis for threat evaluation and engagement control. It is also the function of air defense command and control to provide sufficient identity information, bearing, and range to the allocated weapon system so that the weapon system is able to acquire and engage a target with a high degree of confidence. Acquisition and engagement information processed in a timely manner will permit effective weapons employment. An IFFN system should also provide the necessary information to allow passage of friendly and neutral targets.

B. THE AIR DEFENSE PROCESS

Identification is an integral step in the air defense C² process and begins with tasking and disposition of assets for air surveillance. The process continues through detection of an intruding target and ends with a decision to engage the target with an air defense weapons system. This process is characterized by complex relationships between air surveillance, C², and weapons systems. The targets will be identified as friendly, neutral, hostile, or unknown. The hostile targets will be given different priorities for engagement or may be engaged by other air defense assets. Air defense C² must have sufficient identity information to evaluate the intent of hostile targets and assess the threat level posed by those individual targets. Air defense C² must then prioritize those targets for engagement, allocate the targets for engagement by specific weapons systems, and aid a weapon system in acquiring that target without endangering other targets. This must be done in a constantly changing air environment where identity determination is a dynamic process involving people, hardware, and software.

The classical sequence of air defense is detect, identify, engage, and destroy. This classical sequence used by the IFFN Testbed is a simplification built from a number of decisions and functions performed separately or mutually by C² elements and air defense weapon systems. Most of these functions and decisions are dependent upon identification. Complicating this simple sequence is the fact that identification is both a process and a decision. As a process, identification is a constant gathering and correlating of information about a potential target from all sources of direct and indirect identification information. This process is continuous up to the final disposition of a target by the air defense system. As part of the identification process,

the C² system must correlate information from all sources and resolve any conflicts. As a decision, an identification must be made before further action can occur, either actively or by default. This decision is influenced by all the sensors available to the air defense system, by the background intelligence on the air situation, and by the operational procedures such as rules of engagement and weapons control status. The decision-maker must either make or delegate the identification decision prior to the engagement decision. [Ref. 3: p. 8]

When performing the classical air defense sequence within an integrated air defense system, the identification decision is also part of a larger process which is performed by both C² elements and air defense weapons systems. The process becomes more complex when additional sources of direct and indirect information are available and higher levels of command and control participate. Individual weapon systems are simultaneously performing detection, tracking, and identification as part of their target acquisition function. They can be aided in performing this function by the command and control system as it exercises its function of engagement control. When operating autonomously, weapon systems are limited to their organic detection, tracking, and identification capability. The detection, tracking, and identification of the entire system can be better used for target allocation and acquisition when the command and control system provides engagement control in a centralized mode of operation. Identification is a major factor in the performance of weapon systems to defeat the enemy.

C. IFFN JOINT TESTBED CONCEPT

The Department of Defense's proposed partial solution to the NATO air defense problem was the development of the IFFN Joint Testbed to gather analytic data on the problem so that solutions could be formulated. The testbed will assess baseline US capabilities within the NATO air defense C² system to perform the IFFN function, identify deficiencies in the performance of that function, and propose potential near-term procedural and equipment modifications for further testing. One issue that will be addressed by the IFFN Testbed is the indirect information process and how its use may improve the performance of air defense systems to aid C² and weapon systems nodes. A testbed approach was taken so that a number of different C² strategies could be tested without having to actually use the real equipment and weapons. The testbed was envisioned to simulate as close as possible the real threat and the U.S. equipment and procedures used in NATO. [Ref. 3: pp. 1,2]

The level of complexity of the air defense C² system is enormous, thus, the IFFN Test Force expended a large amount of effort in understanding general C² systems before modeling the NATO air defense C² system. A simulation testbed was ultimately chosen to evaluate the alternative air defense C² systems. The IFFN Test Force is attempting to determine air defense identification measures of performance (MOPs) and measures of effectiveness (MOEs) that will lead to the evaluation of the utility of the different configurations of the air defense C² architecture.

1. Baseline Architecture

The IFFN baseline architecture was formulated as a combination of hardware, software, procedures, and doctrine that is planned to exist in the late 1980's. The criteria will also be subjected to the projected Warsaw Pact 1987-1990 threat and is consistent with Defense Intelligence Agency estimates of enemy capabilities and orders of battle for that period. The timeframe chosen was a compromise between possible near-term benefits and results which will have long range applicability. Certain modifications that will be fielded in 1987 or beyond will be candidates for follow-on tests using the IFFN testbed. [Ref. 3: p. 3]

The testbed geographical area of interest is the NATO environment in which US Army and Air Force units operate jointly and under the control of associated elements of the NATO Air Defense Ground Environment (NADGE) System. The IFFN testbed will focus on the battle management area of a representative NATO Control and Reporting Centers (CRC) located in the Forth Allied Tactical Air Force (FATAF) area. Representation of key associated NATO command and control nodes and information sources is required in the IFFN testbed. Figure 3.1 depicts the key components of the IFFN Testbed. [Ref. 3: pp. 3-6]

a. Command and Control Units

Command and control units are those representative units which direct or control the beyond visual range (BVR) weapon systems and execute the active air defense mission. The specific command centers that perform these C² functions are: Sector Operations Center (SOC), Control and Reporting Centers (CRC), Brigade Fire Direction Centers (Bde FDC), and Battalion Fire Direction Centers (Bn FDC).

b. Information Sources

Sources which provide information for identification, target allocation, and target acquisition in the air environment to the C² units and weapon systems are categorized as information sources. These are: NATO Airborne Early Warning

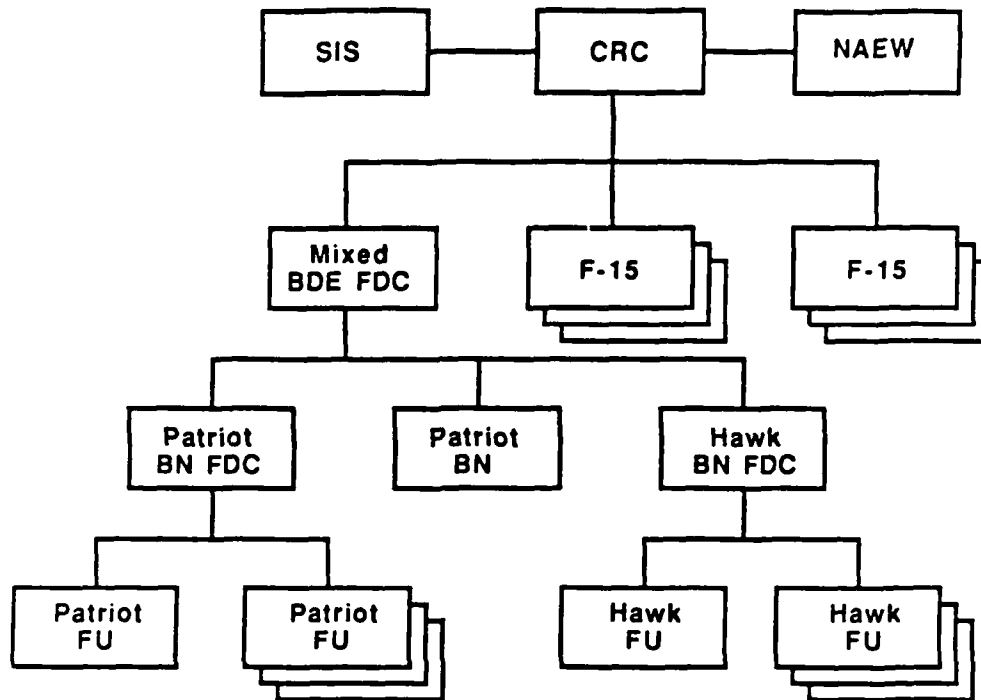

Figure 3.1 IFFN Air Defense Structure.

systems (NAEW), Special Information (intelligence) Systems (SIS), and other information sources (i.e., flight plans).

c. Weapon Systems

Weapon systems are those representative BVR weapon systems which are operated by US forces. For the IFFN Testbed, the F-15, HAWK, and PATRIOT have been selected as the representative BVR weapon systems. Due to resource constraints on the IFFN Testbed, only these three weapon systems will be used.

2. Major Operational Issues

The testbed will generate and record the data necessary for analysis and recommendations on IFFN issues. There are three major operational issues considered by the IFFN Testbed which are listed below.

a. Issue 1

"What is the contribution of indirect identification information to the ability of US air defense command and control systems operating in NATO to correctly identify airborne targets, to use identification in performing target allocation, and to aid subordinate air defense weapon systems in performing target acquisition?"

[Ref. 10: p. 2]. Indirect ID information is that ID information that is not direct electronic IFF returns. Indirect information usually refers to all other ID information that arrives as a facility such as flight plans, area of operations, intelligence reports, etc. However, direct ID information once passed to another facility also becomes indirect ID information. Satisfying the first major operational issue will provide a baseline assessment of the expected identification performance of a representative NATO air defense system operating in the 4ATAF area. Studying the first issue will also provide a fuller understanding of the relationship between the identification performance of the C² system and the performance of the overall active air defense mission.

b. Issue 2

"What are the deficiencies in air defense system use (collection, formation, dissemination, and use) of indirect identification information for which solutions are not currently planned?" [Ref. 10: p. 2]. The second major operational issue will identify weaknesses in the identification process and allow for a qualitative comparison of those weaknesses identified during testing. Potential corrective actions for these identified deficiencies can then be developed. These recommended corrective actions could take the form of changes in doctrine, procedures, system software, communications connectivity, or addition of new data sources, or various combinations of these solutions.

c. Issue 3

"What near-term procedural and equipment modifications should be recommended to overcome deficiencies?" [Ref. 10: p. 2]. This issue will address productive near-term solutions to the IFFN problem.

3. Hybrid Approach

Two major options were considered during feasibility studies when developing the test concept. Field exercises and computer-based simulation were both evaluated and compared. A hybrid approach was ultimately selected which permits the use of the best of both options. The concept is centered around live operators using actual tactical hardware and accepted simulations of hardware and software called Live Participating Units (LPUs). Real-time computer models stimulate the LPUs as well as represent the background workload for these units. This man-in-the-loop simulation will be carried out through all the tests. Since the IFFN Joint Test Force developed a hybrid simulation testbed composed of simulated participating units, there was no

requirement for live operation of aircraft, weapons, radars, nor field deployment of weapons and command and control systems. To implement this test concept a distributed testbed was established at a central facility at Kirtland Air Force Base, New Mexico. The testbed at Kirtland generates and distributes the tactical scenario, controls test execution, and monitors the response of geographically distributed Patriot and Hawk LPUs at the Army Air Defense Center at Fort Bliss, Texas.

A realistic scenario environment was necessary to ensure realistic and accurate results. The combination of a few high fidelity LPUs responding to simulated and manned units was determined to be an excellent method to simulate the interdependency and interaction of air defense units. The IFFN Test Force conducted a substantial testbed certification effort with joint service participation to validate and calibrate testbed performance against joint and combined field exercises for the first test series. Further credibility and validity tests will be made after each test series.

4. Models

The IFFN models that were developed can be categorized as interactive or noninteractive. The interactive models react dynamically to perceived changes in the air battle situation. They may receive inputs such as data link messages from the other models or LPUs and may initiate messages in response to this input or their own. The output of these models is dependent on the specific dynamics of the air battle. The applications of the interactive models for the IFFN testbed are: sensor models, missile models, and dynamically controlled aircraft models. Examples include radar, electronic IFF, Patriot SAMs, and fighter and attack aircraft platforms. [Ref. 10: p. 10]

The IFFN noninteractive models do not react to the air battle dynamics. They are less complex models and simply generate selected messages and actions at preprogrammed times according to a script prepared prior to the test. The models are considered suitable for simulating those facilities that do not dynamically interact with the identification process, but do provide orders, procedures, and other information on a one-way basis such as certain higher echelon planning facilities. Noninteractive models will also be used to simulate aircraft following programmed flight profiles which are not automatically reactive to the air battle environment. The Sector Operations Center (SOC) is an example of a noninteractive model used in the IFFN Testbed simulation. Examples of weapon platforms are transport, patrol, and tanker aircraft. [Ref. 10: p. 1-4]

D. TESTBED PHASES

In order to minimize technical and program risks, a phased testbed acquisition was adopted. The test approach is based on seven test series. The series will consist of weapons systems, command and control systems, and associated data links. One of eight planned phased simulations has been completed. The following is a description and list of the systems involved. [Ref. 10: pp. 3,4]

1. Test Series 1

Series 1 tests the identification performance of a representative US Army Surface-to-Air Missile (SAM) System which is the PATRIOT fire unit. The systems tested are:

1. PATRIOT Fire Unit (FU), and
2. PATRIOT Air Defense Information Language (PADIL).

2. Test Series 2

Series 2 adds the PATRIOT's first echelon of command and control, the Battalion Fire Direction Center. The systems tested are:

1. PATRIOT FU,
2. PATRIOT Battalion Fire Direction Center (Bn FDC), and
3. PADIL.

3. Test Series 3

Series 3 adds the next level of C^2 , the Brigade Fire Direction Center. The systems tested are:

1. PATRIOT FU,
2. PATRIOT Bn FDC,
3. PATRIOT Brigade Fire Direction Center (Bde FDC),
4. PADIL, and the
5. Army Tactical Data Link-1 (ATDIL 1).

4. Test Series 4

Series 4 tests only the USAF's fighter-interceptors, the F-15. The system tested is the F-15 "Eagle" Interceptor.

5. Test Series 5

Series 5 adds associated USAF C^2 nodes and information sources to the F-15 system. The systems tested are:

1. F-15,
2. USAF Control and Reporting Post/Message Processing Center (CRP/MPC),
3. NATO Airborne Early Warning System (NE-3A),

4. Special Information System (SIS),
5. Tactical Digital Information Link - A (TADIL-A), and
6. TADIL-B.

6. Test Series 6

Series 6 will integrate the Army systems from Series 1-3 with the USAF systems from Series 4 and 5. This will now be a joint operations test. The systems tested are:

1. PATRIOT FU,
2. PATRIOT Bn FDC,
3. PATRIOT Bde FDC,
4. F-15,
5. NE-3A,
6. CRP,
7. SIS,
8. TADIL-A,
9. TADIL-B,
10. PADIL,
11. ATDL-1, and
12. NATO Link-1.

7. Test Series 7

Series 7 will add a CRC to form the total system to be tested. The systems to be tested are:

1. PATRIOT FU,
2. PATRIOT Bn FDC,
3. PATRIOT Bde FDC,
4. F-15,
5. NE-3A,
6. CRP,
7. SIS,
8. NATO Control and Reporting Center (CRC),
9. TADIL-A,
10. TADIL-B,
11. PADIL,
12. ATDL-1, and
13. NATO Link-1.

E. IFFN TEST CELL MATRIX

The simulation will be conducted using a controlled variable approach. Different simulation test cells are used in which some variables are held constant while others are left to fluctuate and eventually lead to the determination of the variables' impact on the C^2 system. The basic test structure considers both a fully integrated air defense system and several subsets of the system. The different configurations allow different variables to be isolated to establish their contribution to the particular air defense C^2 system. Each trial will be run with a constant measurement volume of a prescribed radius with only predetermined variables changed. The measurement volume is the area covered by the air defense unit or weapon system. The test cells of the matrix are used to generate comparative data under various environmental conditions. Figure 3.2 represents the basic test matrix of ten test cells used by the IFFN testbed.

Data items are collected from collection messages that are generated by data events during the simulation. Data events are events that take place during the simulation such as information arrival and actions performed by the air defense C^2 system nodes. For Test Series 2, there are fourteen data events that are collected from each test cell simulation to be used in the calculation of the MOEs and MOPs with other data events used for deficiency analysis. All MOEs and MOPs are divided into two groups of probability measures and distribution measures. These measures are not necessarily measures of the variables themselves but are intended to be measures of the results of the variables impact on the C^2 system. [Ref. 11: p. 20]

F. MEASURES

General categories of measures were sought to derive values that would eventually lead to discrimination among the different C^2 systems. The simulation can not completely characterize the performance of the fully deployed air defense systems, so absolute conclusions about the performance of the air defense systems are nearly impossible. With this shortcoming in mind, measures of the relative change in the performance effect of the variable under varying conditions will be used when only large and significant differences are noted. This means that a low confidence level will be used when analyzing the data. Figure 3.3 depicts the general approach taken by the IFFN Testbed in resolving its IFFN issues.

SCENARIO TEST VARIABLE	HIGH ACTIVITY LEVEL	LOW ACTIVITY LEVEL	NO ECM
NOM			
MAX ID			
NO ACP's			
NO Q&A			
VARIANT ACP's			
CENTRAL CONTROL			
DECENTRAL CONTROL			
AUTO FU			
IID			
NO Q&A AUTO FU			

- NOM (Nominal)
- ACP's (Airspace Control Procedures)
- Q&A IFF (Question and Answer Electronic IFF)
- FU (Fire Unit)
- IID (Indirect Identification)
- AUTO (Autonomous)

Figure 3.2 IFFN Basic Test Matrix.

IFFN APPROACH (Without MCES)

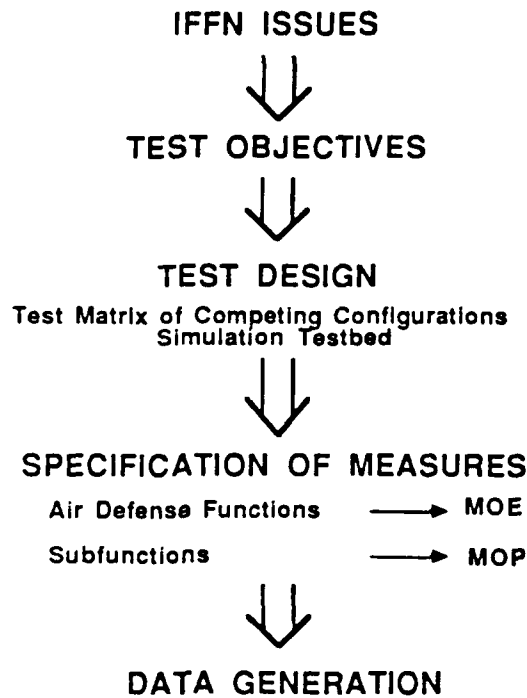

Figure 3.3 IFFN Test Design Approach.

1. Test Series 2 Objectives

There were originally six objectives formulated from the three issues for Test Series 2 that eventually led to the formulation of the IFFN Testbed measures. These objectives are listed below without the more detailed sub-objectives for each objective.

1. Objective 1 - Assess and contrast the performance of the PATRIOT battalion under centralized and decentralized control.
2. Objective 2 - Assess the impact of changing and removing Airspace Control Procedures (ACPs) on the operational performance of the centralized and decentralized battalion and autonomous fire unit.
3. Objective 3 - Determine the value and impact of perfect ID and communication system performance on PATRIOT battalion performance.
4. Objective 4 - Evaluate the impact of various changes in direct and indirect ID performance and interaction.
5. Objective 5 - Assess the influence of the fire unit ID function on the ability of the PATRIOT battalion to perform its functions.
6. Objective 6 - Identify and subjectively evaluate any PATRIOT operational deficiencies noted during testing. [Ref. 11: pp. 2.1,2.2]

2. Measures of Effectiveness (MOE)

There are three primary MOE areas formulated for all the test series. The IFFN Testbed originally identified three functions that were performed in the air defense process: identification, target allocation, and target acquisition. [Ref. 3: pp. 17,18]

a. MOEs for the Identification Function

These MOEs will describe how well the weapons and C² systems are able to identify or recognize airborne objects and assign them to appropriate identification categories.

b. MOEs for the Target Allocation Function

These MOEs will relate identification information used by C² systems to allocate air defense weapons against hostile aircraft and prevention of misallocation of weapons against friendly aircraft.

c. MOEs for the Target Acquisition Function

These MOEs provide the measures relating indirect identification information to the weapons systems. Target acquisition provided by the command and control structure to the weapons systems is a part of these MOEs.

d. MOE List

The MOEs for Test Series 2 that measure the needed information for the C² evaluation issues are listed in Table 2 [Ref. 11: p. D25]. The letter "P" identifies probability measures while the letter "R" signifies range distributions and the letter "T" represents time distributions.

3. Measures of Performance (MOP)

Measures of Performance (MOP) for the IFFN Testbed were submeasures of the air defense functions and therefore subsets of the MOEs. An example is the probability that a passed ID is correct which is a submeasure of MOE 3, probability of identification of an aircraft. The MOPs for Test Series 2 that were determined to measure the needed quantities or qualities to resolve the six stated objectives are listed in Table 3 [Ref. 11: pp. D23,D24] with corresponding MOE number references.

4. Measures of Force Effectiveness (MOFE)

Measures of Force Effectiveness are global measures that determine how effectively the mission is accomplished. Target hits and damage assessments were not modeled in this testbed so MOFEs could not be used.

TABLE 2
MOE DEFINITIONS

MOE#	MOE	MOE DEFINITION
1.	P(D/V)	Probability of detecting an aircraft given that it has entered a system measurement volume.
2.	P(T/D)	Probability of tracking an aircraft, given that it has entered a system's measurement volume and has been detected.
3.	P(I/T)	Probability of identification of an aircraft, given that it has entered a system's measurement volume and has been tracked.
4.	P(A/I)	Probability of allocation of an aircraft, given that it has entered a system's measurement volume and has been identified.
5.	P(E/A)	Probability of engagement of an aircraft, given that it has entered a system's measurement volume and has been allocated.
6.	P(E/V)	Probability of engaging an aircraft.
7.	P(E/F)	Probability of engaging a friendly aircraft.
8.	P(E/N)	Probability of engaging a neutral aircraft.
9.	P(E/H)	Probability of engaging a hostile aircraft.
10.	T(Tot)	Distribution of times elapsed between detection and engagement.
11.	P(EBO)	Probability of engaging a hostile aircraft before it fires a missile or drops ordnance.
12.	R(FE)	Distribution of ranges from aircraft to FSCL at time of engagement.

TABLE 3
MOP DEFINITIONS

MOE ref#	MOP	MOP DEFINITION
1)	R(D)	Distribution of ranges from aircraft to detection unit at time of detection.
1)	R(FD)	Distribution of ranges from aircraft to FSCL at time of detection.
2)	R(T)	Distribution of ranges from aircraft to tracking unit at the time the track was established.
2)	R(FT)	Distribution of ranges from aircraft to FSCL at time of tracking.
2)	T(DT)	Distribution of times elapsed between detection and tracking.
3)	P(IX/YI)	Probabilities of identifying an aircraft as category X (friend, neutral, or hostile), given that its true identity is Y (friend, neutral, or hostile) and that it has been detected.
3)	R(I)	Distribution of ranges from aircraft to identifying unit at time of ID.
3)	R(FI)	Distribution of ranges from aircraft to FSCL at time of ID.
3)	T(TI)	Distribution of times elapsed between tracking and ID.
3)	P(Pass)	Probability that a passed ID is correct.
3)	P(Res)	Probability that an ID conflict is resolved while the aircraft is still in the weapon system's measurement volume.
3)	T(Trans)	Distribution of times elapsed between receipt and retransmission of ID information by a C2 node.
3)	P(Amp)	Probability that an ID includes track amplification information.
4)	P(A/YI)	Probabilities of allocating an aircraft, given that its true identity is Y (friend, neutral, or hostile) and that it has been identified.
4)	R(A)	Distribution of ranges from aircraft to allocated unit at time of allocation.
4)	R(FA)	Distribution of ranges from aircraft to FSCL at time of allocation.

TABLE 3
MOP DEFINITIONS (CONT'D.)

4)	T(IA)	Distribution of times elapsed between ID and allocation.
5)	P(E/YA)	Probabilities of engaging an aircraft, given that its true identity is Y (friend, neutral, or hostile) and that it has been allocated.
5)	R(E)	Distribution of ranges from aircraft to engaging unit at time of engagement.
5)	T(AE)	Distribution of times elapsed between allocating and engagement.

G. ANALYSIS OF DATA

1. Exploratory Data Screening

The test data results are first examined and screened for outliers and to verify underlying assumptions such as normality, independence, constant variances, and zero mean. Various methods are used to statistically check the data. Data screening involves a number of methods listed below. [Ref. 11: pp. D37-D42]

a. Box and line plots

Box and line plots are used for time and range distributions. The box or line plot allows pictorial presentation of a set of distribution measures for a set of trials or number of test cells.

b. Frequency distributions (Histograms)

Histograms are used also for time and range distributions. These show visual evidence of normality as well as extreme outlying values.

c. Scatterplots

Scatterplots are used for time versus range plots distributions. Bivariate scatterplots provide a visualization of the relationship between two continuous variables.

d. Normal probability plots

Probability plots are used to determine probability types and fits. Normal probability plots provide visual evidence of the difference between a given distribution and a Gaussian distribution.

2. Data Analysis

The data analysis that follows screening is listed below.

a. *Paired T Tests*

Means are tested using this test. The assumptions concerning the underlying populations are that they are independent samples and the variances are the same. If they are not, then F tests are used.

b. *Analysis of Variance (ANOVA)*

ANOVA allows inferences to be formulated about differences in "treatment effects" brought about by the test variables which are controlled from cell to cell. Inferences are made by estimating how much of the variability in test data is explained by the effect of the test variables and how much is due to random error.

c. *Hypothesis Testing*

The ANOVA provides a basis for the formal hypothesis test that the trial cell means or specific subgroup means are all equal.

d. *Contingency Table Analysis*

This analysis is sometimes called row by column (RC) table analysis. This test is used when more than two outcomes are possible, a frequent occurrence among the test cells. Each 2x2 contingency table analysis will be performed for comparing probability measures from cell to cell on as many of the measures as practicable.

e. *Regression*

Regression analysis determines the statistical relationship between one or more independent variables and a dependent variable. Curve fitting is accomplished by regression of the dependent variable on the independent variable.

f. *Correlative analysis*

The relationship between the independent and dependent variables or causality is determined by correlation analysis. This analysis determines what proportion of the variation of the dependent variables can be attributed to the relationship with the independent variable.

g. *Standard Normal Theory Approximations*

These series of tests are used to determine what type of probability distribution exists and how good that data fits that distribution.

h. *Deficiency analysis*

After the data has been checked and analyzed, the causes of the differences in the C^2 configurations are proposed and examined. The objective is to find the

underlying cause or reason behind the differences. This could be helpful to decisionmakers in allocating limited resources to different C² configurations. [Ref. 11: pp. D11-D29]

H. IFFN PROGRESS SUMMARY

It is evident that the IFFN Testbed has made progress in its attempt to evaluate the NATO air defense C² system. The IFFN air defense problem is definitely complex and the IFFN Testbed has understandably committed large amounts of resources to the problem. The Testbed is a good concept for an experimental design to test competing C² systems since all of the alternative systems can not be tested using actual equipment due to resource constraints or present C² configuration limitations. The IFFN Test Force has been careful to insure that the testbed is credible. Only Test Series 1 has been completed with Test Series 2 to begin in March 1987.

IV. PROPOSED MCES APPLICATION TO THE IFFN TESTBED

A. INTRODUCTION

Primary research into the application of MCES as an evaluation tool for the IFFN Testbed was undertaken by Major Patrick Gandee, U.S. Air Force, when he was a Naval Postgraduate School student. Two Military Operational Research Society (MORS) teams also contributed to the proposed MCES application during two MORS conferences. The bulk of Major Gandee's and the MORS teams' work with the IFFN Testbed is included in Major Gandee's thesis [Ref. 12] and later refinements by Major Gandee as a staff member of the Joint Chiefs of Staff Command and Control Systems Directorate [Ref. 9: pp. 49-58]. Dr. Ricki Sweet, who was Major Gandee's thesis advisor, provided the then current MCES methodology guidance. This application study was also supported by the Naval Postgraduate School and the Office of the Joint Chiefs of Staff. Major Gandee received assistance from IFFN Testbed personnel including Colonel Dave Archino, Director, and Major Mike Grey, Chief, Operational Analysis Section. These IFFN Testbed personnel also participated in the MCES application to the IFFN Testbed. The following application is mainly taken from Major Gandee's thesis, notes, and briefings along with Major Grey's notes and conversations plus research of IFFN Test Force test plans.

B. PROBLEM FORMULATION

Utilizing the first MCES module, the MORS team and Major Gandee reformulated the IFFN problem which was a subset of the air defense C^2 process problem. Within air defense C^2 , the emphasis was on allocating multiple hostile targets to weapons systems for engagement. Major Gandee understood that this air defense C^2 process description should consist of a complete set of battle management functions which were needed to direct the weapon systems to perform the air defense mission. Other issues considered by Major Gandee in the first module were the different evaluation levels and analysis objectives. Issues such as procedural control and centralized and decentralized control were also researched and reviewed. Figure 4.1 lists the major actions taken by Major Gandee in applying MCES to the IFFN Testbed.

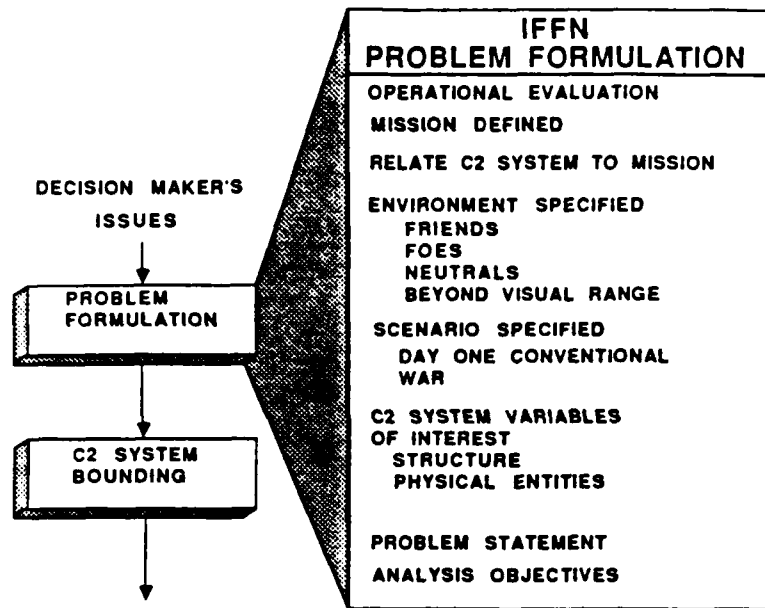

Figure 4.1 IFFN Application of MCES Module 1.

The IFFN Testbed had focused its analysis on specific concerns of Army, Air Force, NATO, and DOD decision makers regarding the role of identification as it contributes to the effectiveness of the air defense C² process. The major concern expressed by the IFFN Joint Testbed was the determination of how the programmed C² system and weapon systems would operate together. The IFFN mission and its environment (friends, foe, neutral, weather) had already been specified prior to Major Gandee's MCES application. The friendly weapon systems were limited to SAMs and fighters with beyond visual range (BVR) munitions. A conventional threat scenario was already chosen by the IFFN Test Force so that stress on the C² system could be affected by varying traffic volume, ECM jamming to radars, communication jamming and varying weather conditions. [Ref. 1: p. 65]

The final step addressed by Major Gandee in this module was the analysis objective. The overall air defense C² analysis objective was reformulated by the January 1985 MORS workshop from IFFN issues. The analysis objective [Ref. 2: p. 1] was to determine:

How effective is the air defense C² system in the central region in Europe in providing decisionmakers the means to assess and employ air defense assets to meet overall mission objectives?

Major Gandee realized that identification can be affected by the presence of a physical entity or an asset like the airborne command post or by procedures such as those used for passing identification information. The IFFN analysis objective was eventually expanded by Major Gandee to determine:

1. How effective is the C^2 process when the C^2 structure and its attendant changes in tactics and procedures is varied.
2. How effective is the C^2 process when physical entities are added or lost. [Ref. 2: p. 3]

The details of formulating the analysis objective involved interaction between the decisionmakers, operational users and analysts. [Ref. 12: pp. 21-23]

C. C^2 SYSTEM BOUNDING

In the next module, the bounding of the C^2 system of interest was confirmed by Major Gandee from previous IFFN efforts. Figure 4.2 lists the condensed results of implementing Module 2 for the IFFN Testbed. Physical entities were identified and bounded and Figure 4.2 depicts the successful application of the "onion skin" idea. Alternative organizational structures were determined and hierarchal charts formulated. Again, much of this had been accomplished earlier at the IFFN Testbed but not by using specific MCES methodology. The application of this module confirmed that the IFFN C^2 bounding was sound. [Ref. 12: pp. 21-26]

D. C^2 PROCESS DEFINITION

1. Air Defense C^2 Process Functions

In this module, Major Gandee defined the C^2 process functions of the distributed C^2 air defense system. The air defense C^2 process functions were determined to be: detect (D), track (T), identify (ID), assess threat (TA), assign weapon (WA), allocate weapon (AW), and weapons monitor and control (C). Figure 4.3 depicts the air defense C^2 process. These air defense C^2 process functions were mapped to the modified Lawson's C^2 process model to ensure that all C^2 functions had been considered and Figure 4.4 depicts that translation. [Ref. 12: pp. 32-37]

These air defense functions represented what the air defense C^2 system and weapon system are required to accomplish together to perform the mission. For the IFFN Testbed application, a process function was added to Lawson's generic C^2 loop and the plan function was eliminated. Lawson's plan function did not correspond to a real-time activity during the IFFN execution phase, however, non-real time plans such as airspace control procedures (ACPs) and rules of engagement (ROE) are a part of weapons assignment, allocation, and control.

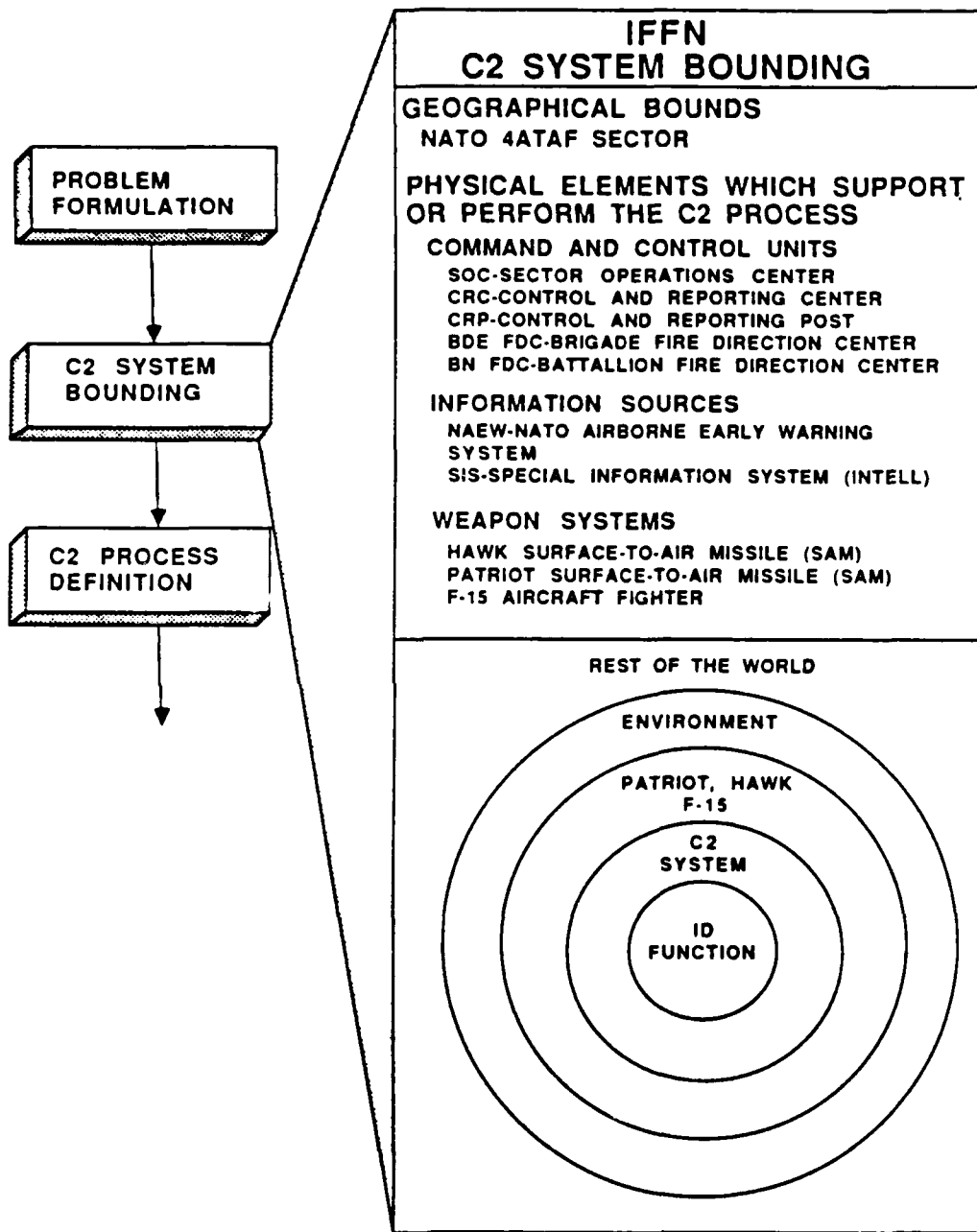

Figure 4.2 IFFN Application of MCES Module 2.

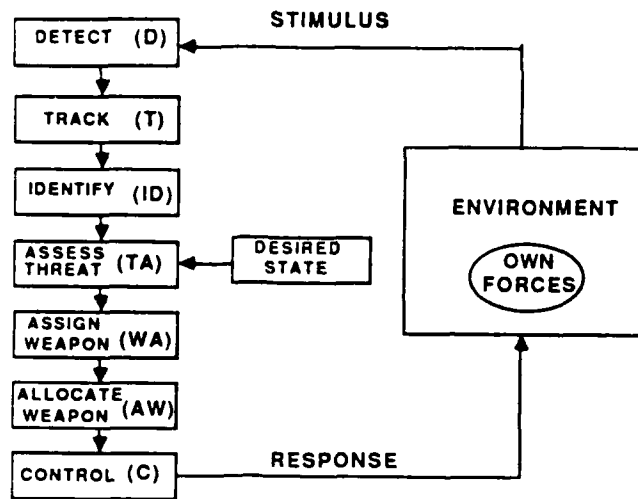

Figure 4.3 IFFN Air Defense C² Process Functions.

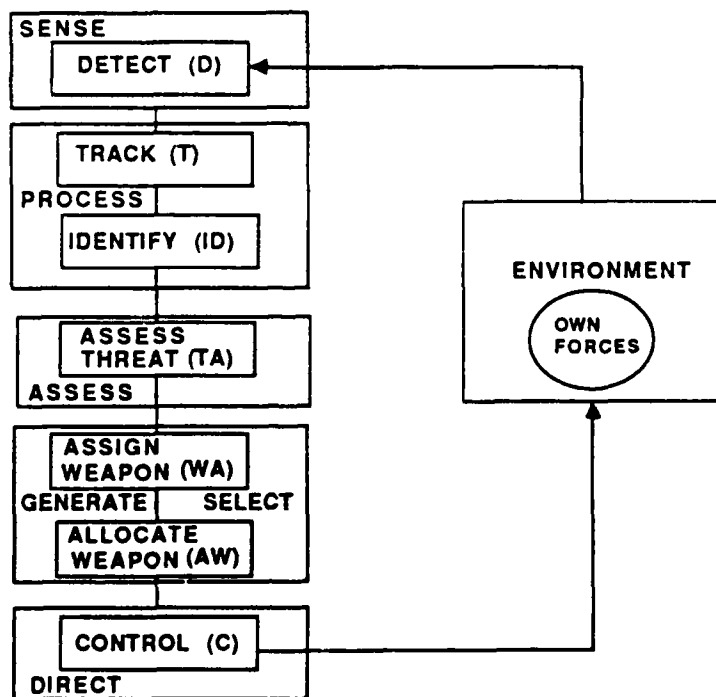

Figure 4.4 Mapping of Air Defense C² Functions.

2. Distributed C² Process Interface

Since the IFFN Testbed was dealing with a distributed C² system, the determination of C² process function boundaries was sometimes complex. Major Gandee discovered that in a distributed command and control system there are three distinct processes that will affect the overall performance of the C² system; intelligence, crosstell (coordination), and execution level C² processes. [Ref. 12: pp. 38,39]

a. XTELL Process

A separate Crosstell (XTELL) process provides a way to share target information for the purpose of improving the overall picture of the environment and improving the accuracy of information. This is especially important for identification (ID) information in the air defense application where command centers are geographically dispersed. Individual command centers may develop definitive ID information which can be used by other command centers who have a tactical advantage or resources to engage the target. The XTELL process is accomplished through three functions of Crosstell (XTELL), Track Correlation (TC), and ID Conflict Resolution (IDC). The XTELL process is represented in Figure 4.5 with its C² process interface.

The XTELL function of the XTELL process is the transfer and receipt of information via data link with some rules or filters. These rules specify where information is to be sent and what information will be received. The Track Correlation (TC) function resolves location and track numbering disagreements in the C² system. The ID Conflict Resolution (IDC) function resolves conflicts that may arise in the identification process between different C² nodes. At some nodes, this IDC function is a fusion process while at other nodes it is a decision process.

Figure 4.6 represents the XTELL process in a lateral relationship. This lateral relationship represents adjoining units of the same level passing coordinating information between them. This information is then fused and correlated. A vertical or hierarchal XTELL relationship can also be present in distributed C² systems. The vertical XTELL process is similar to the lateral relationship except that now the coordinating information flows between the hierarchical related units. The fusion and correlation of the identity and track information may be different than that in the lateral relationship since the higher level unit will usually have more voice in resolving conflicts of information. The alternative C² systems have various configurations of these types of XTELL relations making some the configurations quite complex.

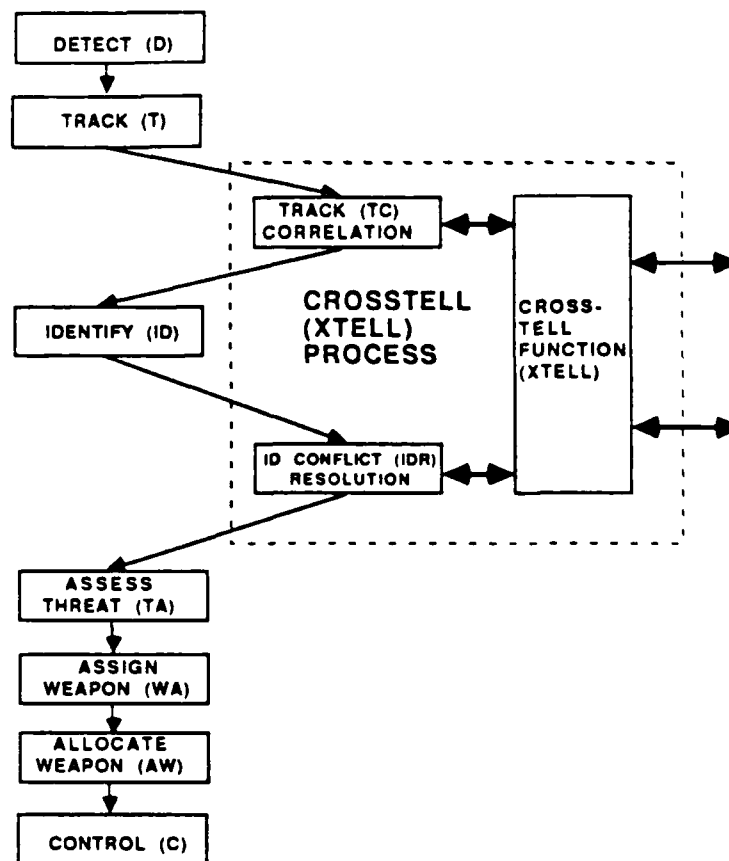

Figure 4.5 XTELL Process Functions and C² Process Interface.

b. INTELL Process

An Intelligence (INTELL) process aids decisionmakers throughout the C² system in forming perceptions of enemy capabilities and intentions. The INTELL process is accomplished through four functions of Sense (S), Process (P), Intelligence Correlation (IC), and Assess (A). [Ref. 12: pp. 39-42]

The function which collects data necessary to describe and forecast the environment is termed the Sense (S) function. The function that transforms data into information about the enemy forces' disposition and actions is termed the Process (P) function. The Intelligence Correlation (IC) function correlates intelligence information with track and ID information. The Assess (A) function is performed when information is examined and patterns uncovered that indicate the actions or intentions of the enemy. The Assess function is also performed when patterns are utilized to forecast possible future changes in environment. Figure 4.7 graphically depicts the INTELL and C² process along with the XTELL process.

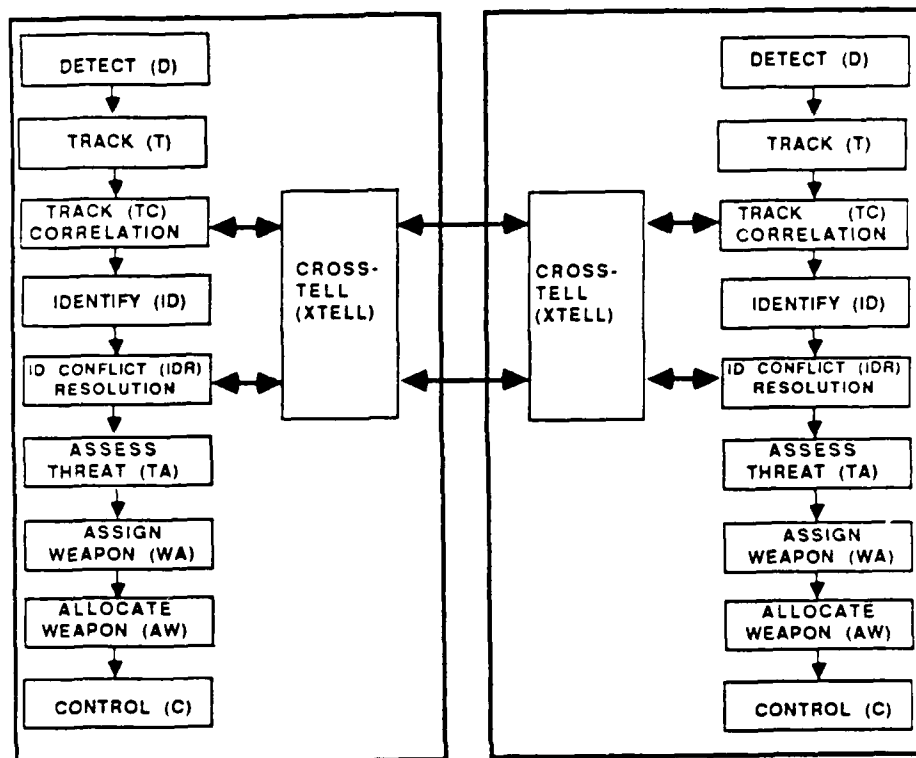

Figure 4.6 Lateral XTELL Process.

c. Execution Level C² Process

The INTELL and XTELL processes support the Command and Control Process. The C² process can be viewed at a level which directly controls weapon systems and at a higher echelon which coordinates the efforts of C² processes which direct the weapon systems. Since the IFFN Testbed simulates the NATO air defense system which is geographically distributed, the C² process included a netting of the separate command centers through the XTELL process. The INTELL process will also be interfaced with some of the process functions. The interfacing of the XTELL, INTELL, and C² processes together by communication links, protocols, operational procedures determined the overall C² architecture. Figure 4.8 lists the major actions completed in Module 3. [Ref. 12: pp. 44-46]

E. INTEGRATION OF SYSTEM ELEMENTS AND FUNCTIONS

Prior to developing measures, Gandee felt that a model or architecture that described the system was definitely needed. When Gandee attempted to establish an

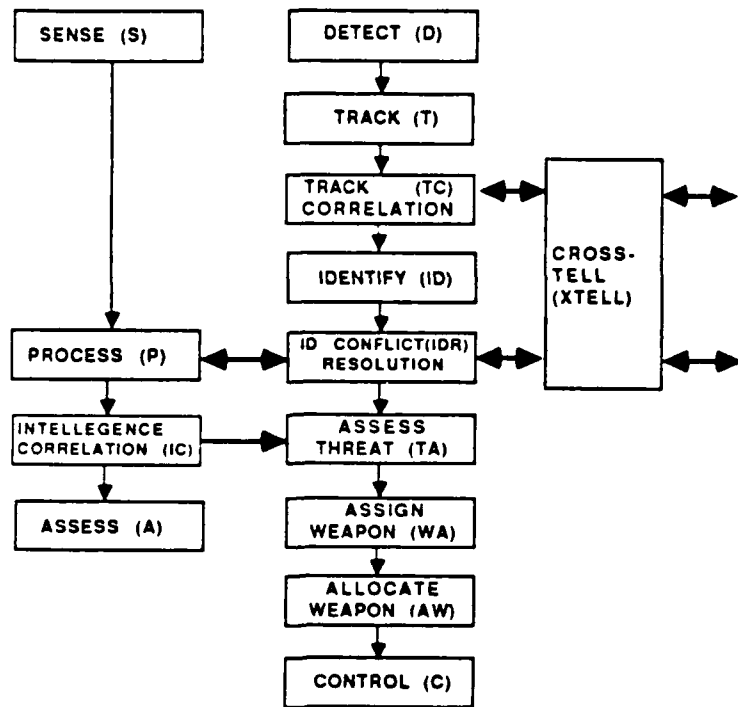

Figure 4.7 INTELL, XTELL, and C² Process Interface.

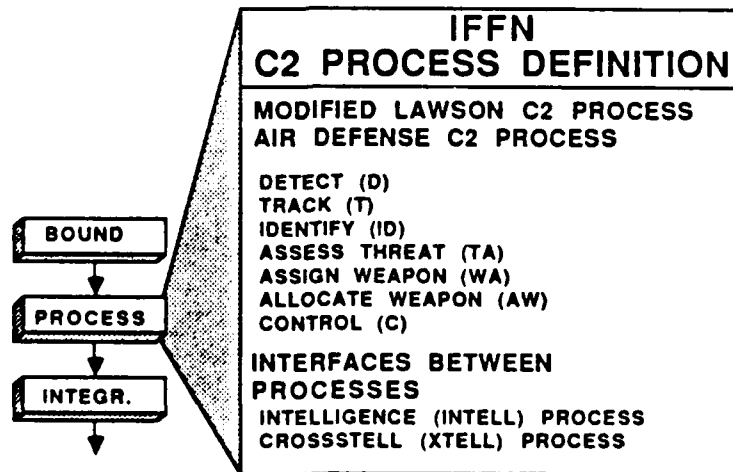

Figure 4.8 IFFN Application of MCES Module 3.

architecture for the air defense C^2 system, he found that he needed a number of actions not listed in the then current MCES methodology. The methodology for interfacing all the processes into an architecture was not covered completely in the original version of MCES. The developers of MCES adopted this idea of the integration of system elements and functions into an architecture to support the C^2 evaluation.

1. Structures

Information flow through the air defense C^2 process functions was used by Gandee to derive a natural hierarchical relationship between the individual C^2 functions in the form of an information flowchart. Later command organizations and equipment and communications alignment were also related to form an organizational structure chart. [Ref. 9: p. 54]

Major Gandee needed a methodology that documented this internal processing and described how the information is input to and output from the function. There are a number of methods available to formulate and describe the internal processing of C^2 functions. In this module, a specific software design technique, Data Flow-Oriented Design [Ref. 7: pp. 99-115] was used to integrate the system elements and functions of the C^2 system. Thus, this input output relationship could form a description of the internal information flow between separate process functions as required to perform the mission. The end result was a "structure" for a particular version of the C^2 system. The MCES definition of "structure" states that structure identifies the arrangement and interrelationships of physical entities, procedures, protocols, concepts of operation, and information patterns. [Ref. 12: p. 48]

a. Data Flow-Oriented Design

In the first step, each C^2 process function was examined and the data flowing through the function defined. A graphic representation of this process is termed a data flow diagram (DFD) and they describe the input output relationships that exist between the C^2 functions. Figure 4.9 depicts a data flow diagram (DFD) for an "execution level" C^2 process at a single command node. The DFD's were also applied to interface the INTELL, XTELL, and Force processes with the C^2 process in the distributed IFFN C^2 system. Major Gandee described how that information flow linked those separate processes into an architecture of the complete C^2 or combat system. [Ref. 12: pp. 47,48]

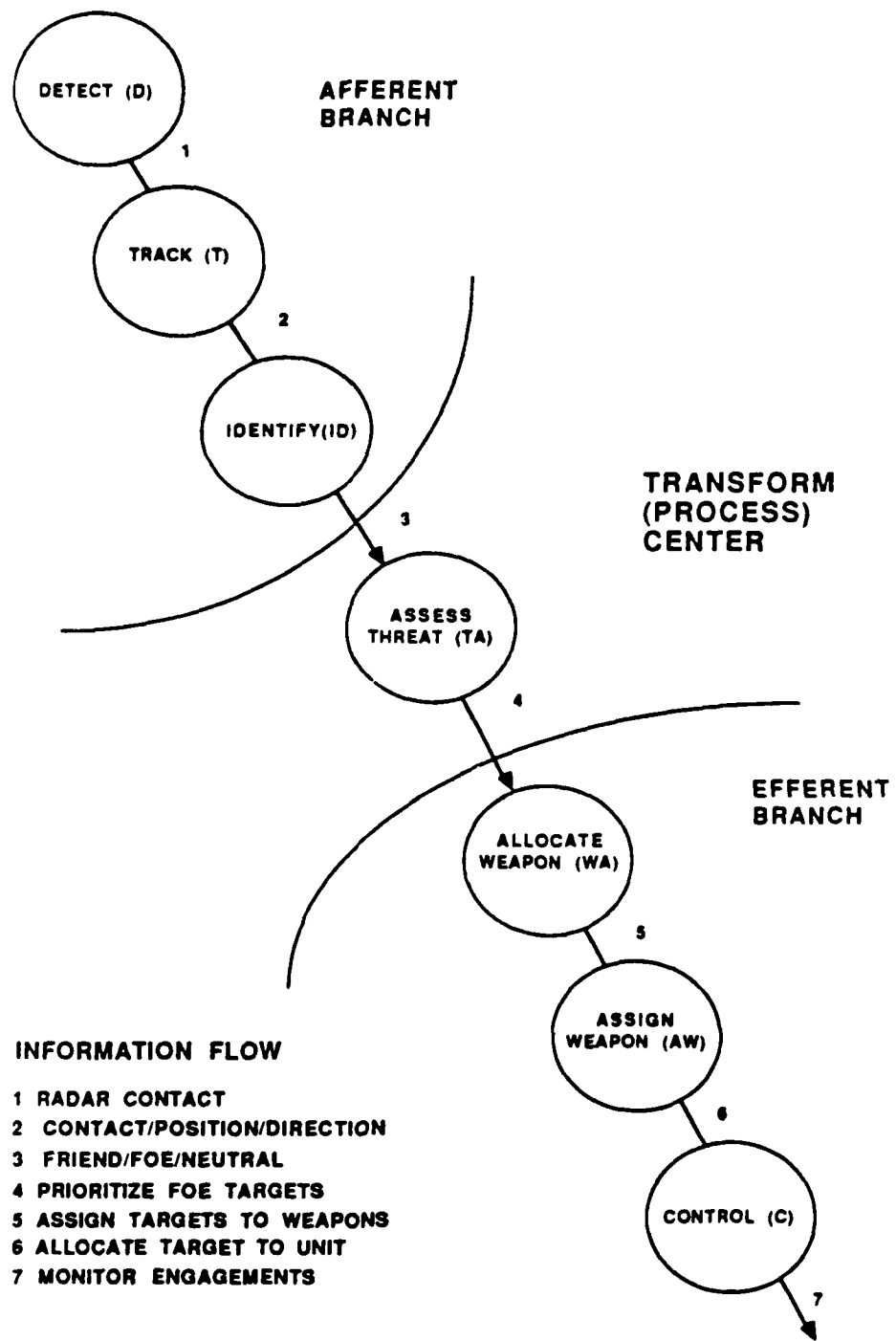

Figure 4.9 Air Defense Single Node Data Flow Diagram.

b. Transform Analysis

In the next step, the C^2 process as a whole was reviewed and a transform analysis performed on the DFD to determine the C^2 process or transform center. Using this flow of information into and out of each function, a transform analysis was conducted to determine the information transforming process center where information flowed in and where the information was transformed into an output in the form of control information. A C^2 function is analogous to a data flow transform. An example is shown in Figure 4.9 which depicts the Assess Threat function as the C^2 process or transform center of the basic air defense process where the main perception is formed. Information flows in to formulate this perception and is termed the afferent branch. Information flows out in terms of decisions based on this perception and constitutes control flow and is termed the efferent branch. Structurally, this Assess Threat function subordinates the others and it was designated as the C^2 process center. A structure chart was derived from this transform analysis which shows the overall structural relationships between each C^2 process function. This process center was then used to establish the structural hierarchy between C^2 process functions. This hierarchical relationship between C^2 process functions was presented as a structure chart. All these C^2 functions can be potentially performed in a single node or be distributed between different nodes.

After the functional structure is formed, the people and their equipment can then be matched to that structure. Major Gandee's gave an example of the battle commander performing the Assess Threat function supported by the identification officer. The commander also has subordinate weapon assignment officers who implement his decisions to attack the most important targets. Major Gandee found that the equipment consoles can be matched to this structure as capabilities to assign targets or control weapons can be implemented by configuring consoles to address their output in accordance with the specified "structure". [Ref. 12: pp. 48-50]

c. Null Process Concept

Under some operational concepts, C^2 process functions can be distributed between command nodes such as Brigade and Battalion FDCs or between command nodes and weapon systems such as the CRC and fighter. The C^2 process functions can be divided. Such arrangements are often temporary and unique to the particular version of the C^2 system. Major Gandee developed the concept of a null process to differentiate between the C^2 process functions when they are distributed. For example,

the Brigade FDC allocates to the Battalion FDC and the Battalion FDC allocates the weapon system. Only one C^2 process can direct a weapon system although its decisions may be influenced by information coming from other C^2 processes. Influence can come in the form of an indirect ID or priorities from a higher echelon. Each command node can potentially perform all C^2 functions to direct force actions in the environment. Figure 4.10 and Figure 4.11 depict the distribution of C^2 and force functions between a Battalion FDC and SAM battery for two differing operational concepts of centralized and decentralized control. A function can be null at a facility due to a physical limitation such as the null Detect function at the Battalion for lack of organic radar or due to a redistribution of decision functions to reflect a different operational doctrine.

With these techniques, the C^2 system architecture was changed to show relationships between "physical entities", and "processes", to produce a "structure". This structure was altered to reflect different operational concepts which form the different versions of the C^2 system. There should be a different structure for each alternative system. Figure 4.10 is a good example of the structure of a battalion employing centralized control of its battery fire units and is different than the structure in Figure 4.11 of a Battalion employing decentralized control of its battery fire units. In these illustrations, the null functions are not enclosed by a box. [Ref. 12: pp. 51-53]

d. Procedures

Procedures are utilized in the internal processing within C^2 functions. For instance, some IFFN issues deal with ID value of air space control procedures. These rules or procedures are specified externally but used internally within the ID function to determine ID. These rules, when combined with other sources for ID into some decision loop or algorithm, affect the internal "structure" of the ID function. If these procedures are taken away then the decision loop (internal structure) is changed. Major Gandee used a design technique which provides a module description that explodes each C^2 function to define the internal processing and the coupling to other C^2 or force functions. In this approach the functions were related to an appropriate physical entity prior to determining relevant measures of performance (MOP), measures of effectiveness (MOE), and measures of force effectiveness (MOFE). [Ref. 9: pp. 54,55]

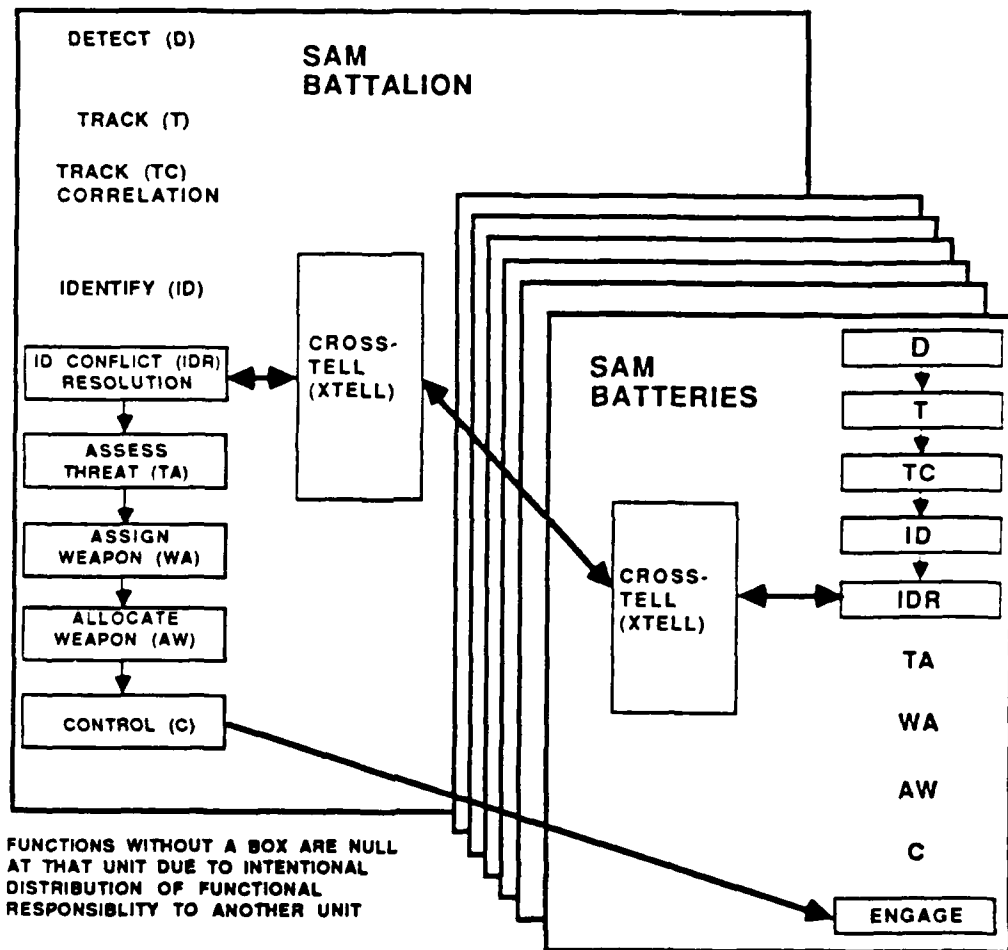

Figure 4.10 Centralized Control of a Battalion Fire Unit.

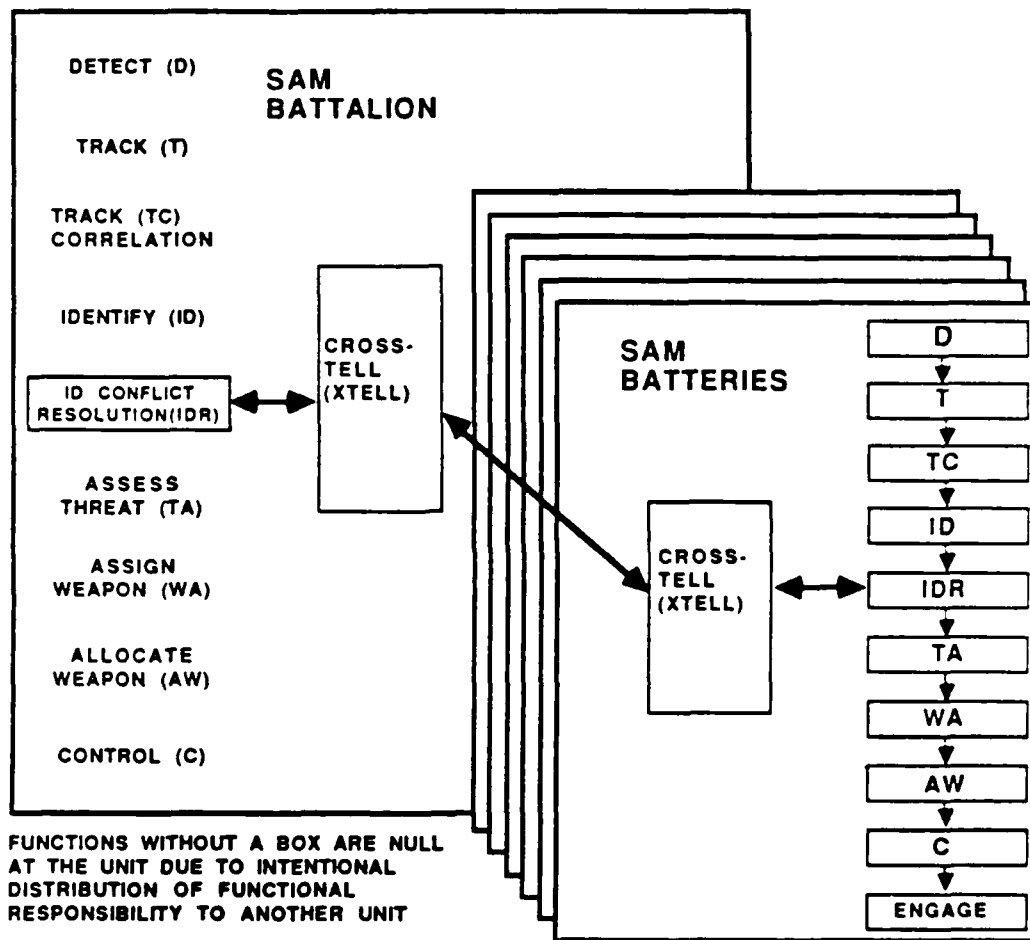

Figure 4.11 Decentralized Control of a Battalion Fire Unit.

2. Architecture

The MCES defines "architecture" as an description of a integrated set of systems whose physical entities, structure and functions are coherently related. The architecture provides a representation which will eventually lead to the ability to measure the C^2 system response and the effectiveness of directing forces to accomplish the mission. The integration of the system elements of man and machine with the process functions will eventually form an overall architecture that can be used by analysts to evaluate the C^2 system. The final step is to formulate a overall C^2 system architecture that will incorporate all the different version structures internally. The last step in completing the architecture was to identify what physical entites performed the individual process functions and what connectivity linked the functions together. This established a single architecture represented as an overall structure chart. The final form of the architecture includes the process description and system elements performing the processes arranged in a structural framework. Additional modules to the structure chart provided documentation for equipment, personnel requirements, and connectivity in the necessary detail.

The general C^2 architecture will remain unchanged but the structure variations would be represented by the different version's unique information flow. An air defense example was illustrated by Major Gandee to describe how structures can differ internally in a C^2 system architecture. This illustration involved air defense operators located in front of consoles. Equipment consoles could be configured in various ways to aid the operator in performing certain functions and allow the output to be transfered to other consoles. The operator would be aided in his ability to process information and communicate it through a machine structure that parallels an organizational structure. The general C^2 architecture would be the same but there would be unique structures utilizing the equipment and personnel differently. [Ref. 12: pp. 48-50]

Major Gandee listed three advantages for utilizing an architectural representation of the C^2 system. Major Gandee found that the C^2 process can be broken down into separate functions and appropriate attributes defined more systematically than previous brute force or exhaustive listing methods. For example, the major Identify function attributes were relatively easy to determine as accuracy, timeliness and completeness. The second advantage of an architectural representation is the cabability of defining where a measure should be taken to measure a certain

function. Certain operational concepts have the same function performed at different nodes or levels. Therefore, measurements must take place where the function is being conducted. For example, the Allocate Weapons (AW) function is performed at the Battalion level in the Centralized Control mode, Figure 4.10 , but is performed at the Fire Unit level, Figure 4.11 , in the Decentralized Control mode. The Battalion just monitors the Allocate Weapons function activities in the Decentralized Control mode. If an accurate architecture depicts the actual operations of the C² system, these relationships are clearly delineated. A third very important reason for architectural representation is its capability to graphically depict the C² system and weapon systems and highlight appropriate operational issues. [Ref. 9: pp. 54-56]

Major Gandee's work did result in the addition of more objectives and ultimately additional measures to Test Series 2 as new relationships were uncovered. Figure 4.12 displays the major results for the implementation of Module 4 to the IFFN Testbed.

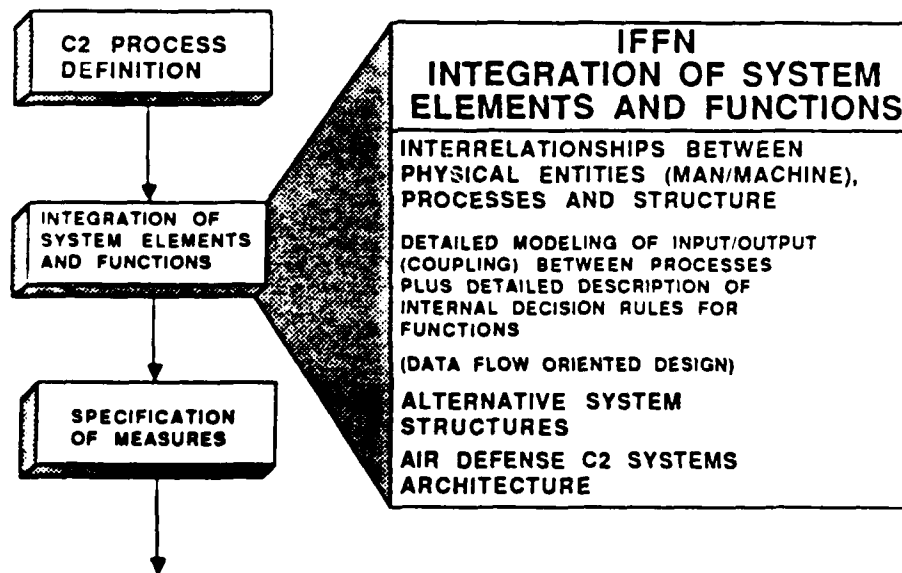

Figure 4.12 IFFN Application of MCES Module 4.

F. SPECIFICATIONS OF MEASURES

Major Gandee used a different approach than the IFFN Testbed when determining the measures needed to evaluate the competing versions of the air defense

C² systems. Instead of moving from issues to objectives to measures to answer those objectives, Major Gandee examined the information flow and bounded system elements to determine which measures were needed. Figure 4.13 graphically depicts Major Gandee's approach for determining measures for the air defense C² system. In this figure, the shaded area represents the functional air defense C² system. The MOPs are measures of each function within the C² system. Each function is dependent on those functions preceding it, so the MOPs are conditional probability measures with additional range and timeliness measures not shown. MOEs measure how well the C² system performed all its functions as a whole and is measured outside of the C² system.

1. NCES Test Series 2 Issues

Major Gandee illustrated some of the issues he considered concerning identification, centralized control, and network connectivity for Test Series 2. Focusing upon such issues lead to the differentiation among the alternative architectures.

- Issue 1: Will centralized control at the Battalion manage the missile resources better by spreading the fire power more evenly over subordinate units and over time?
- Issue 2: Under what traffic volume conditions can centralized control be handled without degradation?
- Issue 3: If the data links (XTELL process) carry information on which targets have been allocated for engagement, can SAM batteries operate in a self-deconflicting manner conserving missile resources?
- Issue 4: Given decentralized control and self-deconflicting doctrine, is a fully connected data network required to prevent a single point failure due to the possible destruction of a Battalion Firing Unit?
- Issue 5: Will the XTELL network supply the most complete ID to the other SAM batteries when their ID equipment becomes inoperable? [Ref. 9: pp. 57,58]

2. NCES Measures

Major Gandee's first four issues for Test Series 2 were sensitive to structural changes. Major Gandee suggested possible efficiency and coordination measures which would reflect the probability of a target being engaged by more than one unit due to lack of coordination. The fifth issue of identification questioned whether a network could increase individual unit identification capabilities. This could be accomplished by supplying more complete ID information from other units which formulate the ID information. Major Gandee suggested that an ID accuracy measure could be used to compare the accuracy of an ID formulated at an organic unit and the ID information which passes over the network to other units as a system ID. Examples of generic MOEs are: timeliness, accuracy, survivability, capacity, and percent completion.

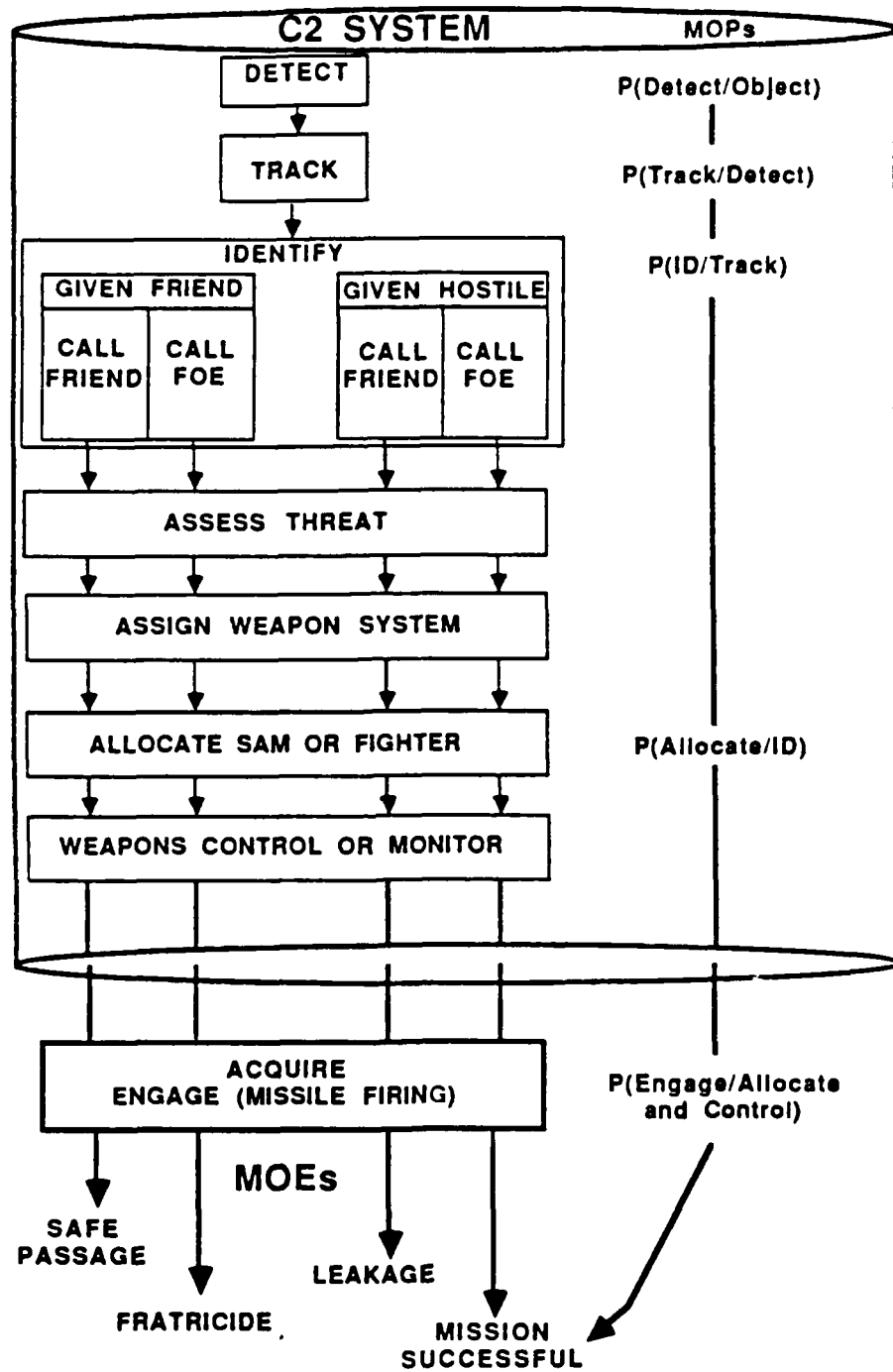

Figure 4.13 MCES Approach for Determining Measures.

Other possible measures suggested by Major Gandee were fusing measures that measured the ability of units to accept and fuse system ID information with its own organic ID information to improve the ID accuracy in time to use it effectively. Figure 4.14 represents the major measures recommended by Major Gandee during the MCES application of Module 5. [Ref. 12: pp. 71-76]

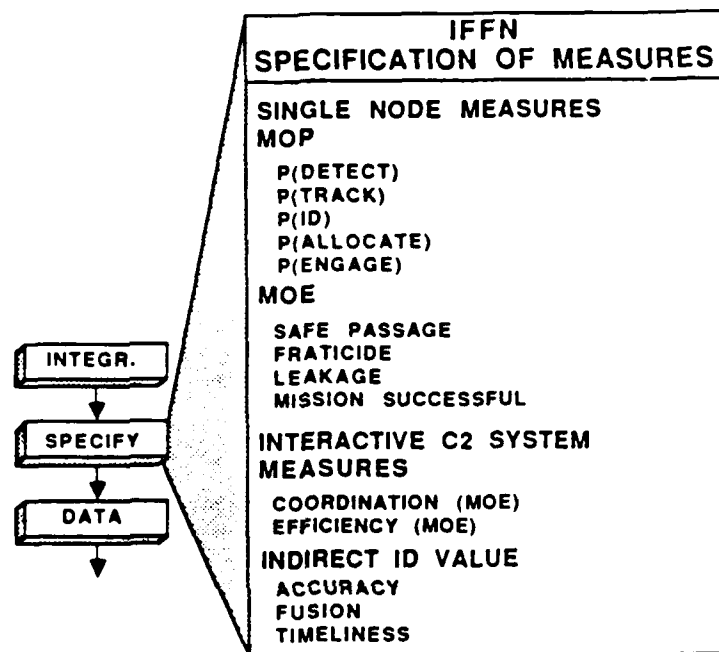

Figure 4.14 IFFN Application of MCES Module 5.

G. MCES APPLICATION SUMMARY

Major Gandee's proposed application of MCES to the IFFN basically stopped at Module 5, Specification of Measures, due to time constraints and the delay of Test Series 2 execution. As a result, the MCES data generation and aggregation and interpretation modules were not evaluated for Test Series 2 by Major Gandee. The MCES methodology provided a evaluation methodology to assist the IFFN Test Force in its evaluation of the air defense C² problem. The MCES approach of systematically outlining the physical entities, structure, and C² process functions insured that all evaluation areas were covered. MCES has definitely helped in highlighting the functional measures that have been overlooked in previous C² evaluations. The

distributed functions are required to characterize the coordination and intelligence sharing of distributed C^2 systems. There are different levels of these distributed functions and the C^2 structures can become very complex. MCES's distributed functions did assist in describing these complexities. The MCES concept of using a model or architecture to establish a baseline with alternative structures to represent the competing C^2 systems was very useful in developing measures to differentiate between them. Understanding the system has to take place before attempting to measure its utility and to uncover which variables are responsible. The MCES approach appeared to be detailed and complete and new relationships were uncovered by Major Gandee. MCES provided the IFFN C^2 analysts with a theoretical framework for determining the utility of a C^2 system. The MCES application did assist the IFFN Testbed.

V. ANALYSIS OF THE IFFN TESTBED AND MCES APPROACHES

A. FEEDBACK TO THE DECISION-MAKER

Major Grey, Chief, Operational Analysis section, IFFN Joint Test Force, and the IFFN testbed director, Colonel Dave Archino, participated in the MORS workshop and later incorporated some of the MCES ideas into its test plans. Major Gandee visited the IFFN Testbed, conducted his research, and made his MCES application to the IFFN Testbed with the full assistance of Major Grey. Major Gandee's proposed application of MCES to the IFFN basically stopped at Module 5, Specification of Measures, due to time constraints and the delay of Test Series 2 execution. As a result, the MCES data generation and aggregation and interpretation modules were not evaluated for Test Series 2 by Major Gandee. Due to even another delay in the execution of Test Series 2 until March 1987, the final results were not evaluated during the conduct of this thesis as was originally planned.

Test Series 1 was planned and conducted without the aid of MCES. The early planning stages of Test Series 2 had been completed before the MCES application started. However, when new or better ideas were developed in the MCES application, some of these ideas were added to the Test Series 2 test plan. A strict comparison of the IFFN Testbed produced Test Series 1 results to Test Series 2 would not be valid due to the mixed participation in Test Series 2. In the evaluation of Test Series 2, it was sometimes difficult to determine exactly what part of the test plan was attributable to MCES or the IFFN Testbed. In almost all cases, MCES at least confirmed earlier IFFN Testbed planning. In some cases, MCES provided new insights that were responsible for a better test plan.

B. PROBLEM FORMULATION

Although the problem formulation was completed earlier by the IFFN Test Force, MCES was used to verify that the correct steps were taken. As previously noted, the analysis objective was expanded by the MCES application. The problem formulation revolved around the air defense problem and not around how to build a credible testbed to evaluate competing air defense C² systems. The IFFN Testbed itself was a system that could be evaluated just as the IFFN Testbed was trying to evaluate air defense C² systems. The IFFN Testbed was evaluated as part of its

certification effort. Measures were formulated that would eventually determine if the IFFN Testbed produced valid and credible results. A comparison of the results was conducted between the values of the measures of target identification, allocation, and engagement from the IFFN Testbed simulation and actual Patriot livefire exercises. The building of the testbed itself was a background problem and will be covered in greater detail in the data generation discussion.

C. C² SYSTEM BOUNDING

The bounding of the C² system of interest was confirmed by Major Gandee from previous IFFN efforts. Physical entities were already identified and bounded. Much of this had been accomplished earlier at the IFFN Testbed but not by using the specific MCES methodology. The application of this module confirmed that the IFFN C² bounding was sound. The "onion skin" idea was a useful tool and was subsequently used by the IFFN Testbed to graphically display their bounding.

D. C² PROCESS DEFINITION

The IFFN Testbed originally identified three functions that were performed in the air defense process and those were: identification, target allocation, and target acquisition. The IFFN Testbed did conduct a functional analysis of the air defense process though not in as much detail as the MCES functional analysis. Major Gandee and the MORS team defined the C² process functions of the distributed C² air defense system as: detect (D), track (T), identify (ID), assess threat (TA), assign weapon (WA), allocate weapon (AW), control (C) which were later adopted by the IFFN Testbed.

E. SYSTEM ELEMENTS AND FUNCTIONS

The IFFN Testbed did formulate the alternative C² systems that it wanted to test. Organizational and equipment charts were constructed as well as some information flow charts by the IFFN Test Force. The IFFN Testbed baseline criteria was basically a baseline architecture from which planned derivations would be tested. In this manner the IFFN Testbed accomplished an integration of system elements and functions but in less detail than Major Gandee's application. The MCES application by Major Gandee was more thorough with his information flow charts, organizational charts, and structure charts. Alternative organizational structures were determined and hierarchal charts formulated by both the IFFN Testbed and MCES approaches.

however, Major Gandee's structures were more detailed and complete. Major Gandee, through his use of null functions and adding or deleting physical entities, developed many different configurations for possible testing. The alternative configurations for centralized and autonomous (decentralized) control of the Patriot Fire Units was one of Major Gandee's contributions. This concept was added to the IFFN Testbed's analysis.

F. SPECIFICATION OF MEASURES

General categories of measures were sought by the IFFN Testbed to derive values that would eventually lead to discriminating among the competing air defense C^2 systems. Early in the development of the IFFN Testbed, the analysts realized that they could determine differences between the competing C^2 systems without precisely knowing which variables were responsible for the difference. As the development of IFFN Testbed progressed, the analysts knew they needed to determine which variables were causing the difference.

1. Deriving Measures

When and where does the analyst derive measures in a C^2 system? There were two different approaches considered by the IFFN Testbed as they derived measures to evaluate competing C^2 systems. The MCES approach utilized the C^2 architecture and unique structures to derive their measures. The MCES methodology built a baseline C^2 architecture with alternative structures to derive where and when the measures should be determined. The IFFN Testbed approach utilized issues, objectives, and subobjectives to derive their measures and later built a baseline architecture to determine where to use the measures. The Institute for Defense Analysis (IDA) conducted extensive research in their attempt to determine measures for use by the IFFN Testbed [Ref. 13]. IDA also basically used a functional decomposition of the air defense C^2 system to derive its measures. Alphatec, Inc. developed a petri net model of the IFFN air defense C^2 system and then identified measures to determine the characteristics of each interconnection in the net [Ref. 14]. This massive effort resulted in over 200 measures for their five levels of the system.

There were originally six objectives formulated for Test Series 2 that led to the IFFN Testbed measures. A new list of objectives was formulated after the MCES application and appeared in the next revised version of the Test Series 2 test plan and is listed below. Objectives 2, 6, and 7 were added to Test Series 2 after the MCES application uncovered the need for them.

- Objective 1 - Assess and contrast the performance of the PATRIOT battalion under centralized and decentralized control.
- Objective 2 - Evaluate the contribution of adding C² (Patriot Battalion FDC) to autonomous Patriot fire unit performance.
- Objective 3 - Assess the impact of changing and removing Airspace Control Procedures (ACPs) on the operational performance of the centralized and decentralized battalion and autonomous fire unit.
- Objective 4 - Determine the value and impact of perfect ID and communication system performance on PATRIOT battalion performance.
- Objective 5 - Evaluate the impact of various changes in direct and indirect ID performance and interaction.
- Objective 6 - Evaluate the contribution of Question and Answer (Q&A) IFF devices to Patriot Bn and FC performance.
- Objective 7 - Evaluate the ability of indirect ID information to compensate for the loss of the direct Q&A IFF device at a Patriot FC.
- Objective 8 - Assess the influence of the fire unit ID function on the ability of the PATRIOT battalion to perform its functions.
- Objective 9 - Identify and subjectively evaluate any PATRIOT operational deficiencies noted during testing. [Ref. 11: pp. 2.1,2.2]

2. MOEs versus MOPs

The terminology used by the IFFN Testbed for MOEs and MOPs is directly opposite of the MCES terminology. MCES states that MOEs are measured outside of the C² system and that MOPs are measures of the functions within the C² system. MCES MOPs are used for the C² system measurements. Examples of MCES MOPs would be probability of detection and correct identification. Within the force boundary, MCES Measures of Effectiveness (MOEs) are used for measuring the functions of the C² system. Examples of generic MCES MOEs are: timeliness, accuracy, survivability, capacity, and percent completion. MOEs are used for the boundary measurements between the force and the environment. An MCES example might be the number of enemy aircraft destroyed prior to releasing their weapons.

The IFFN Testbed termed the functional measures as MOEs and their corresponding submeasures as MOPs. The IFFN Testbed MOEs for Test Series 2 would measure the needed information for the C² evaluation objectives. MCES termed these type of measures as Measures of Performance (MOP) since they were measures of the air defense functions. There is obvious disagreement in methodologies as to what to name the different set of measures. This was not an important detail and did not cause too much difficulty.

3. Functional Measures

Major Gandee's approach was to utilize the C^2 functions as the focal point for deriving measures. If this approach is to be strictly followed, then each function would have at least one corresponding probability measure plus time and distance distribution measures. The measures of probabilities and time and distance ranges for each function should be the minimum measures used to measure these functions. Major Gandee proposed these measures and highlighted that all the functions should have corresponding measures. Table 4 lists the measures that should be included for the functions.

TABLE 4
MCES FUNCTIONS AND MEASURES

FUNCTION	
DETECT (D)	P(Detect), Time and Distance
TRACK (T)	P(Track), Time, and Distance
IDENTIFY (ID)	P(Identify), Time and Distance
ASSESS THREAT (TA)	P(Assess Threat), Time and Distance
ASSIGN WEAPON (WA)	P(Assign Weapon), Time and Distance
ALLOCATE WEAPON (AW)	P(Allocate Weapon), Time and Distance
CONTROL (C)	P(Control), Time and Distance

Most of these measures are listed in the test design plan for Test Series 2. Major Grey of the IFFN Testbed does state that the data for all these measures will be available but some were not considered for Test Series 2. Some of these functions will be measured indirectly and the functional measures may be incorporated in later tests if the results of Test Series 2 reveals that they are needed.

4. Distributed Functions and Measures

Major Gandee thought that the measures for the XTELL and INTELL processes must be used to effectively evaluate distributed C² systems. If this is indeed the case then each function should have at least one corresponding measure of performance. Examples of these are shown in Table 5. Most of these measures were used by the IFFN Testbed. The IFFN Testbed will use their measures of P(Pass), P(Res), P(Trans), and P(Amp) to measure the indirect ID information flow which will indirectly measure some of the coordination and intelligence functions. These IFFN measures and definitions are listed for review and comparison.

- P(Pass) Probability that a passed ID is correct.
- P(Res) Probability that an ID conflict is resolved while the aircraft is still in the weapon system's measurement volume.
- T(Trans) Distribution of times elapsed between receipt and retransmission of ID information by a C2 node.
- P(Amp) Probability that an ID includes track amplification information.

TABLE 5
DISTRIBUTED FUNCTIONS AND MOPS

FUNCTION	MEASURES
CROSSTELL (XTELL)	P(Correct Fusion)
Track Correlation (TC)	Timeliness, accuracy
ID Conflict Resolution (IDR)	Timeliness, accuracy
INTELLIGENCE (INTELL)	P(Target Engagement, given IID was used) P(Target Engagement, given IID was not used)
EXECUTION LEVEL C2 PROCESS	P(Correct ID prior to engagement)

5. Operational versus Design/Qualitative Measures

While most evaluations of C² systems center around design qualitative measures such as flexibility, surviveability, availability, etc., the IFFN Testbed used an approach much like the MCES methodology in that the functions of the system were first studied before equipment and personnel problems were considered. These measures are sometimes referred to as operational measures. Examples of operational measures for distributed C² systems are:

- CAPACITY
- ACCURACY
- RESPONSE TIME
- AVAILABILITY
- THRU PUT

The IFFN Testbed did not continue their evaluation to include the design qualitative measures that are definitely needed to determine the utility of a particular competing C² system. Major Grey did state that design type measures would be incorporated in later tests and that the data needed for these types of measures was readily available even for Test Series 2 if the need arose or if a higher authority requested that information. Examples of design and quality measures are:

- EFFICIENCY
- RELIABILITY
- SURVIVABILITY
- USEABILITY
- CORRECTNESS
- MAINTAINABILITY
- VERIFIABILITY
- EXPANDABILITY
- FLEXIBILITY
- INTEROPERABILITY
- PORTABILITY
- REUSABILITY
- ROBUSTNESS
- EVOLVABILITY

Another analyst, Leslie Golliday, listed a set of generic air defense measures, Table 6 [Ref. 15: p. 788], which are similar to what the MCES application had

determined. These measures are more general but the specific measures could be derived from the general measures. Again, the list included function measures as well as design qualitative measures.

TABLE 6
C2 MEASURES FOR AIR DEFENSE

MOP	DEFINITION
Alerting Capability	Measures capability of providing gross positional data on an aircraft at extended ranges.
Cueing Capability	Measures the process of providing specific and timely positional data with tentative identification of an aircraft within a designated range of a unit.
Weapons Control Information Capability	Measures capability to provide weapons control order (WCOs) and rules of engagement (ROEs).
Airspace Management Capability	Measures capability to provide avoidance of engagement of friendly fixed and rotary aircraft.

MOEs

INTEROPERABILITY

RELIABILITY

MAINTAINABILITY

FLEXIBILITY

USEABILITY

SURVIVABILITY

6. Resource Conservation and Reallocation Measures

Major Gandee suggested possible efficiency and coordination measures which would reflect the probability of a target being engaged by more than one unit due to lack of coordination. A network may increase an individual unit's identification capabilities by supplying more complete ID information from other units which

formulate the ID information. Major Gandee suggested that an ID accuracy measure could be used to compare the accuracy of an ID formulated at an organic unit and the ID information which passes over the network to other units as a system ID. Other possible measures suggested by Major Gandee were fusing measures that measured the ability of units to accept and fuse system ID information with its own organic ID information to improve the ID accuracy in time to use it effectively. However, the suggested measures of weapon allocation efficiency, unit ID coordination, ID accuracy, and ID fusing ability were not used by the IFFN Testbed. Some of these attributes could be measured indirectly using some of the other IFFN Testbed measures such as timeliness and the probability of correctly identifying an object to measure ID information fusing ability.

Determining which competing C^2 consumes less missile resources is very important considering the cost and shortage of modern missiles. Also, in a dynamic environment, there will be instances when missile resources will have to be reallocated due to prior destruction of the target, previous allocation to another weapon, higher priority targets in the area or the targets flies out of range. Measures of efficiency and reallocation ability seemed to be crucial differences in the competing C^2 systems. Again, Major Gandee suggested such measures but they were not all incorporated into the current Test Series 2 plan. Research by Alphatec, Inc. with Petri nets also suggested reallocation measures for the IFFN Testbed [Ref. 14].

G. DATA GENERATION AND TESTBED DESIGN

Major Gandee's proposed application of MCES to the IFFN basically stopped at Module 5, Specification of Measures due to time constraints and the delay of Test Series 2 execution. As a result, the MCES data generation and aggregation and interpretation modules were not evaluated for Test Series 2 by Major Gandee.

The current MCES does incorporate a experimental design methodology for building testbeds to generate data. A methodology, Systems Effectiveness Analysis (SEA), was introduced by A. H. Levis and P. Derskin [Ref. 16] for evaluating large scale systems such as testbeds and ultimately integrated into the MCES methodology. To produce valid data, a testbed must be credible and SEA was developed to assist in validating testbeds. SEA was also developed to determine the minimum number of experiments needed to evaluate the system and to formulate a optimal sequence of improvements areas for the competing configurations. Once the testbed was

determined to be credible, experiments could be run that would determine the optimal effectiveness of each alternative C^2 system.

One of Dr. Levis' students, Phillippe Martain, demonstrated how SEA could be applied to the IFFN Testbed. First in the SEA process was the determination of the smallest number of experiments that were needed to be run to evaluate the effectiveness of the testbed system. A simplified mathematical model utilizing Lanchester type combat models was developed to determine the minimum number of experiments required to evaluate the testbed. The testbed experimental results and the mathematical model results could also be compared to insure similar results. In a second phase, a system planning procedure was used to select the best evolution path for the testbed configurations from a fixed set of improvements. SEA can be then used in the last MCES module of Data Aggregation and Interpretation to make adjustments to the testbed experiments. [Ref. 17]

H. OVERLAPPING OF PROCEDURES AND TOOLS

The IFFN Testbed has been working on its air air defense C^2 problem for a number of years and through its iterative process evolved to a solution that was close to the MCES solution. The IFFN Testbed started without the aid of MCES and some of the applied MCES methodology overlapped with the previous methods used by the IFFN Joint Test Force. However, in most cases both methodologies resulted in the same general results. The IFFN Testbed did make changes after the MCES application, but it is not clear if these changes will have a major impact on Test Series 2 since the test has not been completed.

MCES does integrate and imbed current evaluation tools. MCES does not preclude these tools and in fact uses them to obtain a better solution to the problem. Both the IFFN and MCES methods came to the same general conclusions, however the MCES approach appeared to be more complete. The MCES methodology attempts to standardize the analysis by providing a structured template to assist the analysts in their evaluations.

I. Problem Formulation and Bounding

The problem formulation and bounding of the C^2 system were almost identical. Most system analysis methodologies start out in this same manner.

2. Functional Analysis

Other system analysis approaches use the basic input, process, and output approach to describing the C^2 system. Functional and process analysis are being used often in the software engineering environment. These approaches are similar to C. West Churchman's system process of input, process, and output as explained by Schoderbek, et al. [Ref. 18: pp. 8-29]. It is interesting to note that major methodology revisions occurred when analysts attempted to automate systems because they needed to precisely describe and recreate the functioning of the manual system.

3. Model or Architecture Building

The system analysis approach of utilizing the functions of the system to build a systems model has been used in a number of previous evaluations. Other researchers have added methods of modeling that can be integrated into the MCES methodology. A specific example already referenced is Systems Effectiveness Analysis (SEA). Dr. Levis has conducted stimulating research in this bottom-up approach and has integrated it into the MCES methodology [Ref. 19]. The SEA methodology insures that the simulation can simulate the whole range or limits of the interactions between the variables instead of a smaller subset of the interaction range or limit. This can be accomplished by taking established measures and determining their minimum and maximum ranges. The other quantitative methods of SEA can also be applied to the IFFN Testbed.

Petri Nets have been used by researchers and analysts to mathematically model the different structures of information flow in the C^2 architecture in the form of off and on states which can be used to describe a C^2 architecture with unique structures. Alphatec, Inc. [Ref. 14] conducted a study of the IFFN Testbed and constructed a number of different level petri nets to determine what measures were needed to measure what kind and how much information flowed between all the nodes. Basically, each connection between the nodes was an opportunity to measure information flow.

4. IFFN and MCES Measure Specification

The IFFN Test Force used its issues to formulate their original measures. However, there were no major deficiencies in the test design of Test Series 1 which was completed prior to the MCES application. There was prior research conducted by the Institute for Defense Analysis [Ref. 13] and Alphatec [Ref. 14] concerning the evaluation of the IFFN competing C^2 systems and they confirmed the measures derived by the MCES application.

I. COMPARISON SUMMARY

The IFFN Testbed has already taken advantage of the good ideas generated by the MCES application and the Test Series 2 plan has incorporated some of the MCES concepts. Although each methodology used different and similar tools to evaluate the competing C² systems, both approaches came to the same general conclusions. The question of whether the amount of time needed to document all possible interactions in the MCES is really needed is still unanswered. However after utilizing the MCES approach of analyzing the physical entites, organizational structure, and C² functions in a systematic methodology, the IFFN Test Force discovered a number of important measures that they had not focussed on earlier in the test design process for Test Series 2. Only with more testing and comparisons will the true value of the MCES approach to the IFFN Testbed be known. Conclusions and recommendations concerning both the IFFN Testbed and MCES are included in Chapter VI of this thesis.

VI. CONCLUSIONS AND RECOMMENDATIONS

A. IFFN CONCLUSIONS

It is clearly evident that the IFFN Testbed has made some progress in solving some of the IFFN air defense problems. The problem is definitely complex and the IFFN Testbed has understandably committed large amount of resources to the problem. The Testbed is a good concept for an experimental design to test alternative C² systems since all of the alternative systems can not be tested using actual equipment due to resource constraints or present C² configuration limitations. The IFFN Test Force was careful to insure that the testbed was credible. Only one test series has been completed with Test Series 2 to begin in March 1987. The IFFN Joint Testbed has provided an excellent opportunity to test and refine MCES. The IFFN Testbed is still valuable as a suitable data generator for further evaluation and refinement of MCES.

The IFFN Testbed has already taken advantage of the good results generated by the MCES application and the Test Series 2 plan has incorporated some of the MCES ideas. After utilizing the MCES approach of analyzing the physical entites, organizational structure, and C² functions in a systematic methodology, the IFFN Test Force discovered a number of important measures they had not focussed on earlier in the test design process for Test Series 2. The test design issues and measures were modified to accommodate the newly found distributed relationships between C² nodes that were originally not formulated by the IFFN Joint Test Force.

B. IFFN RECOMMENDATIONS

An additional measure approach would be to utilize both operational and equipment design quality measures. The functional measures are operational measures and the design quality measures are more machine and resource oriented. The IFFN Testbed seems to have focused its measures on operational or functional measures and has not taken full advantage of available and possibly critical design qualitative measures such as resource efficiency.

The IFFN Testbed should consider Major Gandee's recommendations on the additional measures of performance and effectiveness, particularly the measures of coordination and resource allocation. Resource allocation, connectivity, availability,

surviveability, sustainability, and flexibility data appears to be available from the data collection points in the simulations. The measures for the XTELL and INTELL processes must be used to effectively evaluate distributed C^2 systems.

C. MCES APPLICATION CONCLUSIONS

The IFFN Testbed has been working on its air defense C^2 problem for a number of years and through its iterative process evolved to a solution that was close to the same results. There is a learning curve associated with applying any new methodology which was quite evident in this IFFN application. During the MCES application to the IFFN Testbed, there was overlap of the evaluation tools used by the IFFN Test Force. Some of the tools used prior to the MCES application to the IFFN Testbed were included in the MCES methodology. MCES does not preclude these tools and in fact uses them to aid in the evaluation to obtain the best results. This MCES application was a good start in the evolving of a generic standard C^2 system evaluation method. The MCES approach of systematically outlining the physical entities, structure, and C^2 process functions insured that all areas were covered. Major Gandee's proposed application was used by the IFFN Operational Analysis section to better understand their air defense C^2 problem. The MCES approach seemed to be more detailed and complete. New relationships were uncovered by Major Gandee resulting in the addition of new issues and measures. MCES has definitely helped in highlighting the functional measures that have been overlooked in previous C^2 evaluations. MCES did assist the IFFN Testbed.

1. Integration of System Elements and Functions Module

Major Gandee uncovered the need for the additional module 4, Integration of System Elements and Functions, that was not originally conceived as a part of the MCES modules. A model or architecture was needed to establish a baseline with alternative structures to represent the competing C^2 systems. The system must be understood before attempting to measure its utility and uncover the variables are responsible for significant differences. By actually using MCES, some problems surfaced which ultimately resulted in refinements to the MCES methodology.

2. Distributed C^2 Process Functions

The distributed functions are required to characterize the coordination and intelligence sharing of distributed C^2 systems. There are different levels of these distributed functions and the C^2 structures can become very complex. MCES's distributed functions assist in describing these complexities.

3. Solid Evaluation Tool

MCES appears to be a viable C^2 evaluation template of current and evolving tools based on solid C^2 theory. MCES has provided the C^2 analyst community with a theoretical framework for determining the utility of a C^2 system.

4. MCES Application to Additional IFFN Testbed Test Series

The IFFN Testbed did revise their Test Series 2 plan to incorporate most of Major Gandee's results of applying MCES. Major Grey has also utilized some of the concepts of MCES to formulate the design plan for Test Series 3. As more test series are completed, a more thorough evaluation of MCES can be made.

D. MCES RECOMMENDATIONS

1. Continued MCES Application to the IFFN Testbed

The application of MCES to the IFFN Testbed should be continued on Test Series 2 and following tests. Due to time constraints and the delay of the Test Series 2 execution, the final results were not available for analysis in this thesis as was originally envisioned. The areas of actual data generation and aggregation of measures and interpretation for Test Series 2 still could be a valuable thesis topic for a follow-on project. This follow-on project could document and evaluate the success of the previous implementation of MCES and observe new implementations. A comparison of Test Series 1 with Test Series 2 results might reveal the differences in the approach and the results with the caveat that Test Series 2 was a slightly different simulation than Test Series 1.

2. Further MCES Testing and Refinement

More beginning to end C^2 applications of MCES should be conducted to continue the evolution of the MCES methodology.

3. Integration of More C^2 Evaluation Tools

MCES does integrate a number of tools and could still integrate more while maintaining its solid theoretical base. The MCES approach is a top-down systems approach with certain advantages and disadvantages. Utilizing Dr. Levis' experimental design and bottom-up approach, Systems Effectiveness Analysis (SEA), would benefit the MCES toolbox. Petri nets show promise of being a good analyst tool for evaluating information flow. Other system evaluation methods should also be researched for addition to the MCES methodology.

4. Standard MCES Terminology and Definitions

MCES developers must decide on standard terminology and definitions to avoid confusion. Although MCES should be robust and flexible to analysts, a firm evaluation theory must be presented in simple, standard terminology.

5. Education and Dissemination

There is a learning curve associated with any new or revised methodology which was quite evident in this IFFN application. After a standard terminology is defined, MCES should be announced and advertised to the C^2 analyst and decision maker community because of its sound theoretical background. More disclosure of MCES is definitely needed. Since MCES does incorporate a number of known tools, MCES should be advertised as a structured approach to utilize C^2 evaluation methods and tools.

LIST OF REFERENCES

1. Sweet, R., *The Modular Command and Control Structure (MCES): Applications of and Expansion to C3 Architecture Evaluation*, Naval Postgraduate School, Monterey, CA, September 1986.
2. Sweet, R., Metersky, M., and Sovereign M., *Command and Control Evaluation Workshop*, Military Operations Workshop, Naval Postgraduate School, Monterey, CA, June 1986.
3. IFFN Joint Test Force, *Joint Test Force Concept Paper*, IFFN Joint Testbed, Kirtland AFB, NM, November 1984.
4. Military Operations Research Society, Air Force Tactical Group, *Proceedings from Modular C2 Evaluation Workshop*, Naval Postgraduate School, Monterey, CA, January 1986.
5. Department of Defense, *Joint Chiefs of Staff Publication 1*, Washington, DC, January 1985.
6. Lawson, J. S., "The State Variables of a Command and Control System," *Proceedings for Quantitative Assessment of the Utility of Command and Control Systems*, National Defense University, Ft. McNair, Washington, DC, January 1980.
7. Pressman, R. S., *Software Engineering: A Practitioner's Approach*, McGraw-Hill Book Co., New York, 1982.
8. Peterson, J. L., *Petri Net Theory and the Modeling of Systems*, Prentice-Hall, Inc., Englewood Cliffs, NJ, 1981.
9. Gandee, P. L., Grey, M. D., and Sweet, R., "Evaluation of Alternative Air Defense Architectures," *Signal*, pp. 47-58, January 1987.
10. IFFN Joint Test Force, *Program Master Plan*, IFFN Joint Testbed, Kirtland AFB, NM, 1984.
11. IFFN Joint Test Force, *IFFN Joint Test Plan (JTP), Test Series 2, Volume 2*, IFFN Joint Testbed, Kirtland AFB, NM, August 1986.
12. Gandee, P. L., *Evaluation Methodology for Air Defense Command and Control*, Masters Thesis, Naval Postgraduate School, Monterey, CA, March 1986.
13. Romano, G. F., and others, *Design of a Joint Operational Test for the Evaluation of the Identification Friend, Foe, or Neutral (IFFN) Process*, Institute for Defense Analysis, Arlington, VA, January 1985.

14. Moore, K. E., Tenney R. R., and Vail P. A., *Systematic Evaluation of Command and Control Systems*, Alphatec Inc., Burlington, MA, 1985.
15. Golliday, C. L., Jr., "Data Link Communications in Tactical Air Command and Control Systems," *IEEE*, No 5, September 1985.
16. Levis, A. H. and Derskin P., *Large Scale Systems Effectiveness Analysis*, Laboratory for Information and Decision Systems, Massachusetts Institute of Technology, Cambridge, MA, 1981.
17. Martain, P. J. F., *Large Scale C2 Systems: Experimental Design and System Improvement*, Masters Thesis, Massachusetts Institute of Technology, Cambridge, MA, August 1986.
18. Schoderbek, P. P., Schoderbek, C. J., and Kefalas, A. G., *Management Systems*, Business Publications, Inc., 1983.
19. Levis, A. H., *Modeling and Measuring Effectiveness of C3 Systems*, Laboratory for Information and Decision Systems, Massachusetts Institute of Technology, Cambridge, MA, September 1986.

INITIAL DISTRIBUTION LIST

		No. Copies
1.	Defense Technical Information Center Cameron Station Alexandria, Virginia 22304-6145	2
2.	Library, Code 0142 Naval Postgraduate School Monterey, California 93943-5002	2
3.	Curricular Office, Code 39 Naval Postgraduate School Monterey, California 93943-5000	2
4.	C3 Academic Group, Code 74 Naval Postgraduate School ATTN: Prof. Michael Sovereign Monterey, California 93943-5000	6
5.	IFFN Joint Test Force ATTN: Major M.D. Grey Kirtland AFB, New Mexico 87117	2
6.	Curricular Office, Code 74 Naval Postgraduate School ATTN: LTC J. T. Malokas Monterey, California 93943-5000	1
7.	Curricular Office, Code 62Bd Naval Postgraduate School ATTN: Major T. J. Brown Monterey, California 93943-5000	1
8.	Major L. W. Moss 708 Oakwood Dr. Euless, TX 76040	1
8.	Sweet Associates, Ltd. P.O. Box 9196 ATTN: Dr. Ricki Sweet Arlington, Virginia 22209	1