



Research Report 1431

AD-A179 827

The Training Implications of Directed Energy Weapons for the U.S. Army: A Preliminary Report

Gary C. Bayer
Mellonics Systems Development Division
Litton Systems, Inc.

ARI Field Unit at Fort Benning, Georgia
Training Research Laboratory



U. S. Army

Research Institute for the Behavioral and Social Sciences

October 1986

Approved for public release; distribution unlimited.

DTIC
ELECTE
APR 29 1987
S D
E

U. S. ARMY RESEARCH INSTITUTE FOR THE BEHAVIORAL AND SOCIAL SCIENCES

A Field Operating Agency under the Jurisdiction of the
Deputy Chief of Staff for Personnel

EDGAR M. JOHNSON
Technical Director

WM. DARRYL HENDERSON
COL, IN
Commanding

Research accomplished under contract
for the Department of the Army

Mellonics System Development Division,
Litton Systems, Inc.

Technical review by

Barbara A. Black
Robert J. Pleban



Accession For	
NTIS GRA&I	<input checked="" type="checkbox"/>
DTIC TAB	<input type="checkbox"/>
Unannounced	<input type="checkbox"/>
Justification	
By _____	
Distribution/	
Availability Codes	
Dist	Avail and/or Special
A-1	

NOTICES

DISTRIBUTION: Primary distribution of this report has been made by ARI. Please address correspondence concerning distribution of reports to: U.S. Army Research Institute for the Behavioral and Social Sciences, ATTN: PERI-POT, 5001 Eisenhower Ave., Alexandria, Virginia 22333-5600

FINAL DISPOSITION This report may be destroyed when it is no longer needed. Please do not return it to the U.S. Army Research Institute for the Behavioral and Social Sciences.

NOTE The findings in this report are not to be construed as an official Department of the Army position, unless so designated by other authorized documents.

SECURITY CLASSIFICATION OF THIS PAGE (When Data Entered)

REPORT DOCUMENTATION PAGE		READ INSTRUCTIONS BEFORE COMPLETING FORM
1. REPORT NUMBER	2. GOVT ACCESSION NO.	3. RECIPIENT'S CATALOG NUMBER
ARI Research Report 1431	AD-A179827	
4. TITLE (and Subtitle)		5. TYPE OF REPORT & PERIOD COVERED
THE TRAINING IMPLICATIONS OF DIRECTED ENERGY WEAPONS FOR THE U.S. ARMY: A PRELIMINARY REPORT		Final September 1983-September 1984
		6. PERFORMING ORG. REPORT NUMBER

7. AUTHOR(s)		8. CONTRACT OR GRANT NUMBER(s)
Gary C. Bayer		MDA 903-80-C-0545
9. PERFORMING ORGANIZATION NAME AND ADDRESS		10. PROGRAM ELEMENT, PROJECT, TASK AREA & WORK UNIT NUMBERS
Mellonics Systems Development Division Litton Systems, Inc. P.O. Box 2498, Fort Benning, GA 31905		2Q263743A794 323 1100
11. CONTROLLING OFFICE NAME AND ADDRESS		12. REPORT DATE
U.S. Army Research Institute for the Behavioral and Social Sciences, 5001 Eisenhower Avenue, Alexandria, VA 22333-5600		October 1986
		13. NUMBER OF PAGES
		109
14. MONITORING AGENCY NAME & ADDRESS (if different from Controlling Office)		15. SECURITY CLASS. (of this report)
U.S. Army Research Institute for the Behavioral and Social Sciences, Fort Benning Field Unit, P.O. Box 2086, Fort Benning, GA 31905		Unclassified
		15a. DECLASSIFICATION/DOWNGRADING SCHEDULE

16. DISTRIBUTION STATEMENT (of this Report)		
Approved for public release; distribution unlimited.		
17. DISTRIBUTION STATEMENT (of the abstract entered in Block 20, if different from Report)		

18. SUPPLEMENTARY NOTES		
Contracting Officer's Representative, Seward Smith.		
19. KEY WORDS (Continue on reverse side if necessary and identify by block number)		
Biological effects of directed energy; Training for Bradley Fighting Vehicle (BFV) Directed energy doctrine; Unit training Directed energy training; Directed energy weapons; Field-expedient countermeasures;		
20. ABSTRACT (Continue on reverse side if necessary and identify by block number)		
This report addresses the need to fill information gaps in training and doctrine on directed energy. A comprehensive presentation of nonclassified descriptions of directed energy types, employment possibilities, and appropriate countermeasures serves as the major portion of this report. Directed energy proliferation on the battlefield is a critical issue faced by commanders and soldiers alike. The results of a pilot test suggest that relatively simple training that can minimize directed energy weapon effectiveness on individual		
(continued)		

ARI Research Report 1431

20. (Continued)

and crew performance can be developed and presented to soldiers.

A closing issue is discussion of directed energy to generate widespread understanding of directed energy effects and capabilities and the need to reconsider the classification level of some information. A large body of directed energy information is currently held as sensitive when in fact it could be made available to concerned field commanders and trainers in a general format. Specified classified details could easily remain sensitive while the release of common knowledge would permit trainers to develop comprehensive responses to the directed energy threat.

Keywords: → + field 19

Research Report 1431 |

**The Training Implications of Directed
Energy Weapons for the U.S. Army:
A Preliminary Report**

Gary C. Bayer
Mellonics Systems Development Division
Litton Systems, Inc.

ARI Field Unit at Fort Benning, Georgia
Seward Smith, Chief

Training Research Laboratory
Jack H. Hiller, Director

U.S. ARMY RESEARCH INSTITUTE FOR THE BEHAVIORAL AND SOCIAL SCIENCES
5001 Eisenhower Avenue, Alexandria, Virginia 22333-5600

Office, Deputy Chief of Staff for Personnel
Department of the Army

October 1986

Army Project Number
2Q263743A794

Education and Training

Approved for public release; distribution unlimited.

ARI Research Reports and Technical Reports are intended for sponsors of R&D tasks and for other research and military agencies. Any findings ready for implementation at the time of publication are presented in the last part of the Brief. Upon completion of a major phase of the task, formal recommendations for official action normally are conveyed to appropriate military agencies by briefing or Disposition Form.

FOREWORD

Today's Army faces a new set of battlefield threats never before encountered in combat. This report addresses one of the new threats: directed energy weapons (DEWs). The reality of DEWs must now be considered when training soldiers for the modern battlefield. Little is presented in the open literature regarding the use of directed energy weapons. As a consequence, it is difficult for the commander, the trainer, and the individual soldier to prepare for combat where DEWs will be encountered.

The primary goal of this document is to serve as a primer on directed energy weaponry. The report focuses on the capabilities and limitations of directed energy use and how these may affect the combat effectiveness of a Bradley Infantry Fighting Vehicle and its crew. Preliminary information formerly available from diverse and sometimes fragmented sources is presented to clarify directed energy weapon implications. Also, this report demonstrates that DEWs will not replace conventional military weapons.

Training developers will find this a straightforward and useful resource for preparing instructional material and for developing crew reaction drills or field-expedient measures to counter directed energy weapons on the modern battlefield.



EDGAR M. JOHNSON
Technical Director

THE TRAINING IMPLICATIONS OF DIRECTED ENERGY WEAPONS FOR THE U.S. ARMY:
A PRELIMINARY REPORT

EXECUTIVE SUMMARY

Requirement:

This research was conducted to determine the preliminary training implications of directed energy weapons (DEWs) for the infantry. Directed energy weapons are a reality of modern warfare; however, there is little training information regarding this subject. This report partially fills this void by presenting the broad implications of directed energy weapons, suggesting field-expedient countermeasures, and identifying areas requiring additional study.

Procedure:

Classified and unclassified literature regarding the status of current U.S. and threat systems was reviewed. In addition, the author made personal contact with key personnel in several agencies.

This report presents an overview of the basics of directed energy weapons. It examines the impact of lasers on the operation of the Bradley Fighting Vehicle (BFV), and suggests field-expedient countermeasures. In some cases preliminary field trials were conducted to test the feasibility of the suggested countermeasures.

The BFV is an excellent vehicle to focus on because it incorporates armor, conventional weapons, direct view optics, a variety of Surveillance, Target Acquisition, and Night Observation (STANO) devices, smoke, mounted and dismounted infantry, and electronics. Once an understanding is gained of how lasers affect each of the BFV's subsystem characteristics, it is possible to conceptualize the effect of lasers on nearly all other Army systems.

Findings:

This report identified six major problem areas:

1. There is general ignorance of DEWs Army-wide.
2. There is a need for directed energy (DE) institutional and unit training program.
3. Current security classifications present training obstacles.

4. There is a lack of DEWs-related doctrine.
5. There is difficulty establishing a body of "facts" regarding DEWs issues.
6. The user community is generally overly optimistic about materiel solutions to the DEWs problem.

Utilization of Findings:

1. There is a general ignorance of directed energy Army-wide.

The most significant finding is there is general ignorance of directed energy issues Army-wide. Much of this ignorance has been due to the highly sensitive nature of DEWs. Previously, it made sense to keep much of this information classified to protect intelligence sources and U.S. plans. Since the Soviets are about to begin fielding DEWs, it is now time to widely disseminate DE information to the troops.

2. There is a need for DE institutional and unit training.

Currently, there are only a few unclassified publications available on the subject of DE, and these are inadequate to meet the Army's needs. A first step would be to develop a "TRADOC Bulletin" type of booklet on DE. It should be mandated that all new institutional publications, e.g., Field Manuals (FMs), Training Circulars (TCs), etc., reflect DEWs information and considerations where appropriate. Further, a comprehensive training program should include classified and unclassified introductory training films on DE, a program to train trainers on the issues and concepts of DE, and the incorporation of DE issues in Army Training and Evaluation Programs (ARTEPs) and other field training exercises.

3. Current security classifications present training obstacles.

Reclassification of anticipated initial operational capabilities (IOCs) of a few specific threat systems and some of the unique capabilities of lasers is needed to disseminate information the Army needs to prepare for DE combat.

4. There is a lack of DE-related doctrine.

Currently, there is no approved doctrine on infantry plans to fight in a DE environment. The issue of how the Army will fight today against a force that has DEWs has been largely ignored. This is a major shortfall in Army preparation.

5. There is difficulty establishing a body of "facts" regarding directed energy issues.

Repeatedly during the course of this research, contradictory "facts" about DE were presented by various sources. This occurs for several reasons: (a) this is new technology and there is disagreement among experts about the true potential for directed energy; (b) there have been rapid major administrative changes in the directed energy program; and (c) there have been upgrading and compartmentalization of security classifications in significant DE areas. These facts make it difficult for trainers to keep current in the evolving DE community. It is suggested that selected trainers have a Top Secret clearance so their work can be guided by the most recent and broad-based developments.

6. The user community may be overly optimistic about materiel solutions to the DEWs problem.

The potential protection that can be expected from the materiel community against the DEWs threat is significant. However, the user community cannot expect miracles from materiel developers. There is no perfect materiel fix to the DE problem. The user community must develop tactics and training that will maximize the contributions of the materiel developers, as well as adjust conventional tactics and training to fight a DEWs-enriched war.

THE TRAINING IMPLICATIONS OF DIRECTED ENERGY WEAPONS FOR THE U.S. ARMY:
A PRELIMINARY REPORT

CONTENTS

	Page
OVERVIEW	1
INTRODUCTION	3
BIOEFFECTS OF LASERS	11
OPTICAL SYSTEMS OF THE BFV	23
OPTICAL SYSTEMS OF THE BFV, LASERS AND FIELD-EXPEDIENT COUNTERMEASURES	30
MICROWAVES	48
CONCLUSIONS AND RECOMMENDATIONS	54
REFERENCES	69
APPENDIX A: Suggested Outline POI Directed Energy Training Program	A-1
B: Crew Performance of a M2 Bradley Under Simulated Laser Attack: A Pilot Study	B-1
C: Washington Post Article, Saturday, December 17, 1983, Laser Weapon Sparks Debate Over Ethics by Michael Schrange	C-1

LIST OF TABLES

Table 1. Characteristics of soft kill vs. hard kill	8
2. Burn thresholds for skin	12
3. Laser threshold for skin damage	14
4. HEL propagation characteristics for one second exposure time	22
5. HEL biological effects from one second exposure	22

CONTENTS (Continued)

Page

LIST OF TABLES (Continued)

Table 6.	HEL propagation characteristics per pulse	23
7.	Amount of smoke in meters required to reduce laser transmittance to one percent of incoming energy	47
8.	Power density and exposure time to produce sensation of warmth	52
9.	Threshold for pain at 3 GHz	52

LIST OF FIGURES

Figure 1.	Vertically polarized electromagnetic wave	5
2.	The electromagnetic spectrum	6
3.	Electromagnetic wave	7
4.	Laser designed to focus at distance	10
5.	Continuous wave and repetitively pulsed beams	11
6.	Depth of penetration into the skin for different wavelengths	13
7.	Radiation reflectance of human skin	14
8.	Cross-section of the human eye	15
9.	Transmission of light waves in the human eye	17
10.	Effects of light on the eye	17
11.	Night and day responses for the eye	18
12.	Absorption of electromagnetic radiation in the eye	20
13.	Absorption of near ultraviolet radiation in the eye	20
14.	Types of laser reflection	21
15.	Diagram of unity window	23
16.	Vision block and periscope locations on BFV	24

	Page
LIST OF FIGURES (Continued)	
Figure 17. Blackout cover	25
18. AN/PVS-4 individual-served weapons night vision sight	26
19. AN/PVS-4 daylight cover	27
20. AN/PVS-5 night vision goggles	27
21. AN/VVS-2 driver's night viewer	28
22. AN/TAS-5 thermal sight	29
23. Integrated sight unit (ISU)	30
24. Electromagnetic spectrum utilized by BFV optical systems - wavelength in μm (millionths of a meter)	32
25. Light reflecting inside of safety goggles	34
26. Tape on vision block with 3mm opening	35
27. Tape on sun, wind, and dust goggles	36
28. A neodymium laser operating at a wavelength of $1.064 \mu\text{m}$	38
29. Ruby laser operating at a wavelength of $.6943 \mu\text{m}$	38
30. Frequency double neodymium laser operating at a wavelength of $.532 \mu\text{m}$	38
31. Proper positioning of optics when in mounted position . .	39
32. Proper positioning of optics when in dismounted position	39
33. Soldier wearing AN/PVS-5 looking through the ISU using his finger as a spacer	41
34. Optical schematic diagram of AN/PVS-4	42
35. Schematic diagram of image intensifier tube	43
36. Block diagram of a thermal device	44

CONTENTS (Continued)

	Page
LIST OF FIGURES (Continued)	
Figure 37. Detailed block diagram of ISU night sight	45
38. Microwaves and the electromagnetic spectrum	49
39. Cross-section of the human eye	51
40. Principles of DEWs warfare	64
41. Gray's countermeasure grid	65

THE TRAINING IMPLICATIONS OF DIRECTED ENERGY WEAPONS FOR THE U.S. ARMY:
A PRELIMINARY REPORT

OVERVIEW

Directed energy weapons (DEWs) are a new class of weapons that use electromagnetic waves instead of bullets to destroy or jam targets. This report explores how these new weapons will affect a Bradley Fighting Vehicle (BFV) squad. The first section of this report is a general introduction to directed energy (DE) which deals with some of the basic operational characteristics of directed energy and the advantages and disadvantages of DEWs. The second section addresses the bioeffects of lasers, a major type of directed energy weapon. The third section describes optical systems of the BFV; and the fourth section addresses the specific effects lasers will have on the BFV optical and electro-optical (OEO) subsystems and offers some suggested field expedient countermeasures. The fifth section presents high-powered microwave technology and how it is related to the BFV; and the final section contains conclusions and recommendations regarding the effective deployment of DEWs and DEWs information.

Warfare will be different in a directed energy environment. What the exact difference will be has yet to be determined. However, it can be safely asserted that the two mistakes which can be made regarding DEWs are to over-emphasize or underemphasize their impact. It would be a mistake to assume that DEWs are all powerful and that it is just a matter of time before they make conventional weapons obsolete. This is simply not true; for DEWs to be effective in the foreseeable future, they must be used as an adjunct to conventional weapons. Conversely, it is also a mistake to believe DEWs can be ignored with impunity.

DEWs can clearly be a force multiplier and the Army must prepare itself to deal with this reality. Just how much of a difference DEWs will make on tomorrow's battlefield is unknown because DE is not only a new, but an evolving technology. The challenge to the Army is to define the nature and scope of DE technology and determine how it can best integrate DEWs with existing weaponry and tactical doctrine.

This document attempts to highlight some of the emerging issues. The primary focus of this report is on how DEWs, especially lasers, will affect a BFV squad. The BFV is an excellent system to provide focus for a discussion of the impact of DEWs because it involves armor, precision-guided munitions, mounted and dismounted infantry, smoke, and a variety of surveillance, target acquisition, and night observation (STANO) devices. Once an understanding is gained of how each of these areas is affected by DEWs, the reader will be adequately prepared to conceptualize how DEWs might impact on virtually all other weapon systems in the Army.

This report is not intended to be a technical manual on DEWs. The Directed Energy Capstone Manual (1982) is an excellent publication which fulfills that purpose. It provides a comprehensive and in-depth summary of

many of the more technical issues involved with DEWs and the reader is referred to that publication for a detailed explanation of the technical issues.

Finally, there is a misconception that the soldier of the future would have to have advanced training in physics or engineering in order to have a proper understanding of the impact of DEWs on the battlefield. While it is true that there are some unique concepts of DEWs which must be learned, this does not imply that soldiers must have a complete scientific understanding of lasers or microwaves any more than they must understand the chemical-mechanical workings of a hand grenade in order to employ it effectively.

INTRODUCTION

Advantages and Disadvantages of DEWs

Lasers, high-powered microwaves, and particle beams are technologies which have military potential as tactical weapons. These new weapons are qualitatively different from conventional weapons. Instead of using explosives to physically destroy targets, DEWs concentrate relatively small but coherent or concentrated quantities of energy on critical areas of targets causing them to jam, malfunction, or burn out.

One of the greatest advantages to DEWs is the fact that the energy "bullets" travel near the speed of light. There is virtually no problem with leading targets. A jet plane at three kilometers distance, flying at MACH 1 (1224 km/hr), would require a lead of 1500 meters and a height adjustment of 95 meters to compensate for the speed and the vertical drop of a MACH 2 bullet (680 m/sec). A laser would hit the same target with just a 3 millimeter lead and no required compensation for vertical drop (Capstone, 1982).

Besides simplified target tracking and acquisition, there are other advantages as well. The munitions are manufactured as needed so there is no logistical train for ammunition. Certain directed energy weapons have enormous magazine potential, hundreds of thousands (in some cases, millions) of "shots" can be generated before reloading (recharging) is required. Because a DEW affects targets in unique ways, several thousand new potential targets on the battlefield will require new countermeasure devices. Also, the addition of these countermeasures may cause weight penalties and performance degradation of the conventional systems. Finally, there is no recoil or noise signature for most DEWs.

However, there are some disadvantages:

1. For the foreseeable future, DEWs will not have a hard kill capability; thus DEWs must be fought in conjunction with conventional weapons.
2. DEW energy efficiency or, the energy placed on the target compared to total energy generated by the system is generally poor, even under the best of circumstances.
3. There can be unique electronic, thermal, and visual signatures.
4. The propagation of directed energy through the atmosphere on a battlefield filled with obscurants, such as dust and smoke, can be a problem.
5. There is an increased danger of fratricide.
6. There is a difficulty with damage assessment because there is little direct feedback from the target as to the effects of a hit. Consequently, one may not know positively if a DEWs attack has been successful.

7. The effects of some DEWs are easily countermeasured.

Lasers

Frequently, when laser weapons are discussed, images from science fiction movies are conjured up picturing a laser death ray radiating on a target for a few seconds followed by the target dramatically vaporizing, exploding, or bursting into flames. For the foreseeable future, such weapons will only appear on the movie screen and not on the battlefield as the electrical power requirements for such a powerful laser weapon are enormous. Furthermore, even the most efficient lasers of today convert only about 30% of the input power to output power making laser weapons capable of destroying armor impractical for tactical use.

More realistically, the first generation laser weapons will be similar to powered-up laser rangefinders or designators. These will be low-energy systems designed to flashblind troops and temporarily jam sensitive electro-optic systems at tactical distances. Because they are unable to produce a "hard kill" in a ballistic bullet sense, these weapons would have to be deployed with other conventional systems to be effective. As this technology evolves, higher energy systems will be fielded, but these still would not produce the dramatic effects of science fiction lasers. Real-world high-energy laser systems would have the capability of extending the ranges of low-energy systems and causing damage at tactically significant ranges.

Radio Frequency Weapons

High-powered microwave (HPM) weapons are radio frequency (RF) weapons which can jam or destroy electrical systems or components. The Soviet Union has demonstrated a major interest in this area and has dedicated significant resources to their development. High-powered microwaves overload electronic components with excessive amounts of energy. At far ranges, components can be jammed or upset; at closer ranges, electronic burnout can occur.

Particle Beam Weapons

Particle beam (PB) weapons are not actually true directed energy weapons because they do not direct electromagnetic waves as lasers and radio frequency weapons do. Rather, PB weapons accelerate atomic particles or subatomic particles, e.g., electrons, protons, and neutrons, to very high speeds and then direct the particles to a target. When these particles crash into the target, they give up their energy in the form of heat. This can cause the target to melt or fracture. This weapon is capable of a hard kill or actual target destruction. In addition, PB can create tremendous amounts of X-ray and gamma ray radiation as the beam interacts with the target thereby causing additional damage to personnel and electronic components.

Both the US and the Soviet Union have interest in this technology, but there are major technical and engineering problems which must be solved before a tactical PB weapon can be fielded. These problems are of such magnitude that PB can only be considered a long-range future possibility.

Key Concepts of DEWs

DEWs differ from conventional weapons in that they deposit concentrated electromagnetic energy rather than bullets on the target. Electromagnetic waves are radiant energy which propagate through space at the speed of light. (These waves are also called photons.) This energy is referred to as an electromagnetic wave because it is actually two inseparable waves, one electric and the other magnetic, which are perpendicular to each other. In addition, it is convenient to refer to this energy as a wave because this energy repeats itself in a predictable manner over time (see Figure 1.)

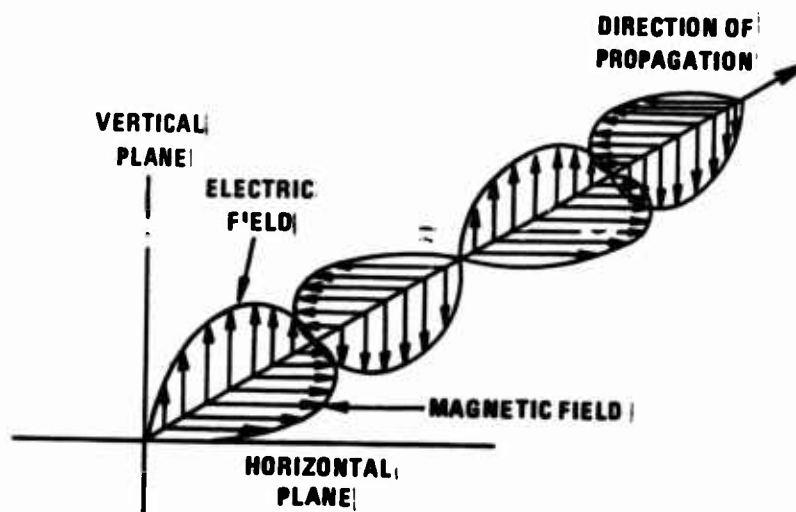

Figure 1. Vertically polarized electromagnetic wave.

Once a target has absorbed this energy, the target will begin to heat up. If the target cannot dissipate the heat fast enough, thermal damage will occur. Also, under some circumstances, this energy could create shock waves as it hits the target causing additional damage.

Common examples of electromagnetic waves are radio waves, microwaves, visible light, laser light, and X-ray. All of these forms of energy are essentially the same except for their frequency, wavelength and coherence.

Some confusion regarding electromagnetic waves once existed because various portions of the electromagnetic spectrum (e.g., radiowaves, X-rays, TV waves) were discovered at different times, and therefore thought to be different. Another factor that added to this confusion is that the equipment needed to generate different types of electromagnetic energy is radically different for

each portion of the electromagnetic spectrum. For example, the equipment required to generate television waves is vastly different from the equipment needed to generate visible light or X-rays. However, it eventually was realized that all electromagnetic waves are essentially the same except for frequency and wavelength and they can be placed on a single continuous spectrum. Figure 2 is a chart of the electromagnetic spectrum showing some of the traditional boundaries.

It should also be noted that there is a difference between electromagnetic radiation and other types of radiation, e.g., heat or sound. Electromagnetic waves differ from heat and sound because they have electric and magnetic fields, they travel at the speed of light, and they do not need a medium such as air or water to propagate.

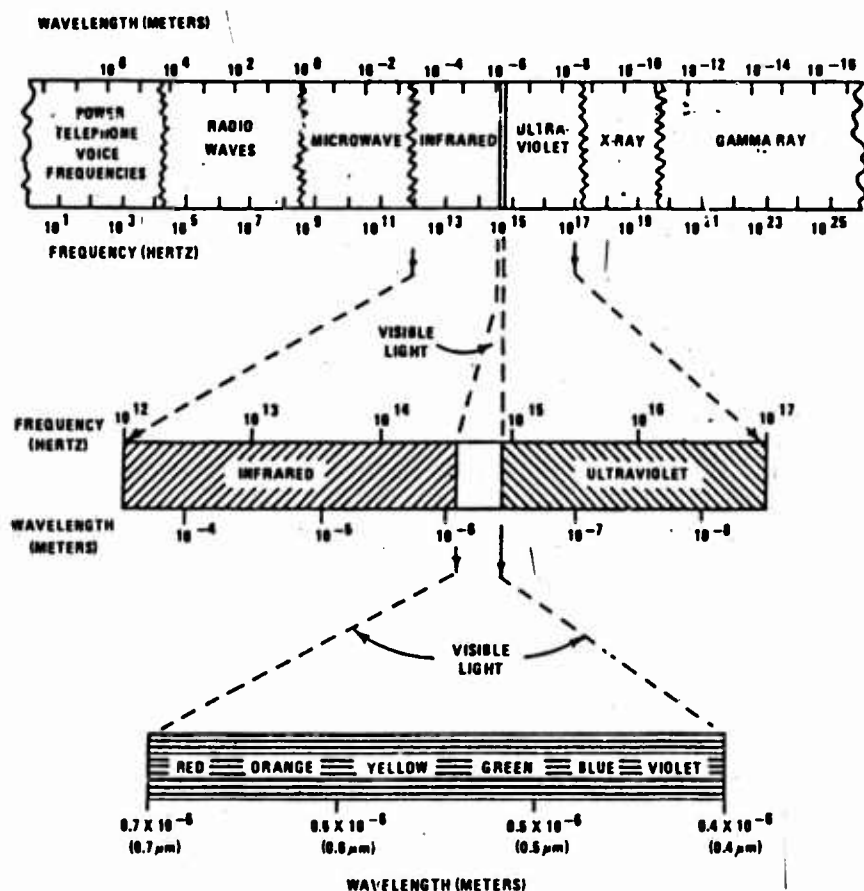

Figure 2. The electromagnetic spectrum.

Another point which is sometimes confusing to the layperson is the fact that electromagnetic waves can be measured in two different ways. Electromagnetic waves can be measured by their frequency, usually in Hertz

(number of cycles per second) or their wavelength (the peak to peak distance). For example, points A and B in Figure 3 could be measured by the distance between A and B (wavelength) or how long it would take A to get where B is (frequency) as the wave moves through space.

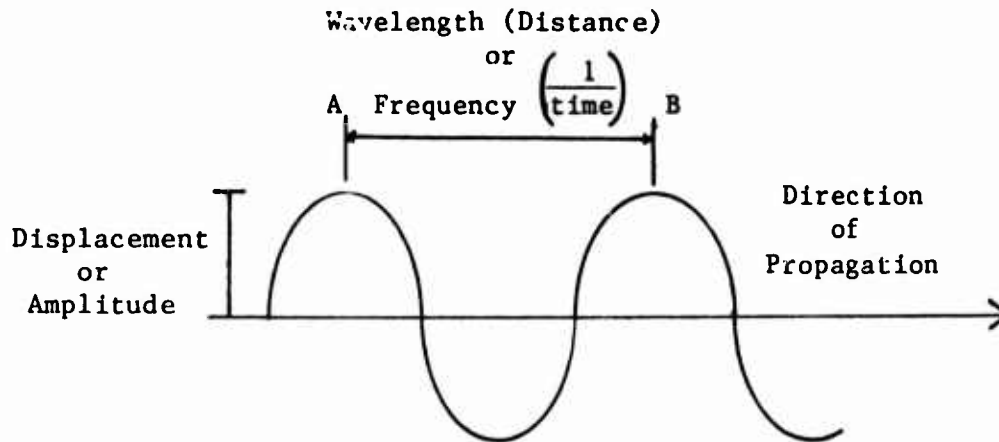

Figure 3. Electromagnetic wave.

A third measure could be the displacement or amplitude of the wave, how much higher or lower the wave travels beyond a neutral position; however, this measure is seldom used.

Wavelengths and frequencies are directly related to each other, as the wavelengths decrease, the frequencies increase. This relationship is determined by the following formulas:

$$\text{frequency} = \frac{\text{speed of light}}{\text{wavelength}}$$

$$\text{wavelength} = \frac{\text{speed of light}}{\text{frequency}}$$

where the speed of light equals 3.0×10^8 m/s in a vacuum.

Consequently, if the wavelength is known, frequency can be determined and vice versa.

Hard Kill vs. Soft Kill

Conventional weapons defeat their targets by causing physical damage to the structure of the target. This structural damage is known as a hard kill. An example of a hard kill would be the physical damage produced by a Tube-

launched, Optically-tracked, Wire-guided (TOW) missile hitting a tank. DEWs on the other hand, cause soft kills or functional kills because they may destroy or disrupt a vital subsystem of the weapon and thereby render it combat-ineffective while leaving a major component intact. An example of a soft kill would be a high power microwave weapon disrupting the electronics of a guided missile causing it to miss its target, or a laser flashblinding a gunner so the gunner is unable to acquire or track a target. Table 1 displays some of the differences between soft and hard kills.

Table 1

Characteristics of Soft Kill vs. Hard Kill

DEWs Effects	Conventional Weapons Effects
jam, disrupt	structural damage
temporary	permanent
little energy	much energy
specific damage	general damage
degrading capability	destroying target

Therefore, for the foreseeable future, DEWs will have to be fielded with conventional weapons to be militarily effective; they presently lack the hard kill capability of conventional weapons.

Determining the Power of DEWs Beams

A central question of military significance is what is the power of a weapon? Unlike many conventional weapons, the power of a DEW varies considerably because of several factors: whether the energy is in-band or out-of-band to a target, whether the energy can enter a system by the "front door" or "back door," the range of the target, how well the particular energy can propagate through the atmosphere, and whether the energy is a continuous wave or pulsed.

In-band/out-of-band. In-band/out-of-band refers to whether or not the electromagnetic waves can pass through a system. For example, a radio receiver can pick up a signal from a radio station, but not a television station broadcasting next to the radio station. The radio is said to be in-band to the energy being transmitted from the radio station and out-of-band to the television station.

Likewise, light can be in-band or out-of-band to human eyes. The human eye is sensitive (or is tuned) to light between .4 μm to .7 μm (μm = 1 millionth of a meter). Thus, electromagnetic energy between .7 μm to .4 μm will pass through the

cornea (outer lens of the eye) to the retina (the area at the back of the eye on which light focuses) and will be seen as visible light. Energy outside this bandwidth will be absorbed by the first surface which it contacts, in this case the cornea. (In actuality the cornea transmits light from approximately .4 μm to 1.4 μm but the eye only has sensors for .4 μm to .7 μm wavelengths.) Consequently, if an eye were hit by an in-band laser, the energy would be transmitted to the retina located at the back of the eye. If it were hit by an out-of-band laser, the energy would be absorbed by the cornea. The range of wavelengths transmitted through the system is called the passband; thus the passband of the eye is .4 to 1.4 μm .

Another example of in-band/out-of-band is the thermal sight on the BFV, which is out-of-band to visible light (.4 μm to .7 μm) but in-band to far infrared light (8 to 14 μm). Thus, the germinium dioxide window of the thermal night sight reflects visible light and appears to be a mirror to human eyes, but it is still able to detect targets because it is collecting electromagnetic energy in the 8 to 14 μm range.

Front door/back door. Front door and back door are analogous to in-band/out-of-band and are used to describe the path the electromagnetic energy uses to enter a system. If the energy is in-band to a system and it enters through a component designed to receive that bandwidth, then this is a front door entry. For example, coming through an antenna would be considered a front door entry.

Back door entry refers to energy that reaches the electronic circuitry without following an intended pathway. Such entry could be HPM energy entering through the seams in a missile skin, cooling ports, or unintentional cracks in the housing of an electronic component.

Range. Unlike some conventional munitions, the impact of DEWs degrades with range. For example, an 81mm mortar round will have the same kill radius whether it impacts 300 meters or 3000 meters from the firing point. DEWs are more like radios: the further the target is from the source, proportionately less energy is placed on the target. Consequently, there is less impact on the target. This is due to the propagation of the energy through the atmosphere and the fact that DEWs beams spread slightly over distance thereby decreasing energy density.

Most people recognize that this phenomenon is true for radio waves, but it is true of laser beams as well. It is erroneously thought by some that laser beams do not spread. The energy rays from a laser are remarkably parallel, but there is beam spread even with the best focusing mechanisms.

A general rule of thumb for tactical laser weapons is one millimeter beam spread for every meter traveled. In more tactically relevant terms, this would be one meter spread for every kilometer. For example, a beam from a laser weapon traveling one kilometer would be one meter wider at the target than when it started. At two kilometers, it would be two meters wider.

This is a very general rule. Lasers can be designed to give a much wider beam spread if desired and some systems may have less beam spread. Also laser systems can be designed to focus their beam to a point at a distance. In such systems, the beam width would gradually decrease to a beam waist and then begin to enlarge (see Figure 4).

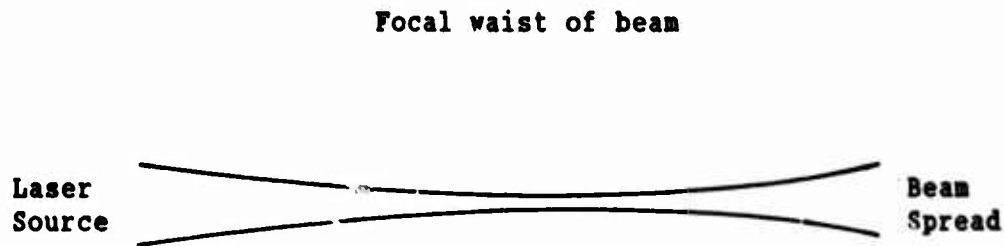

Figure 4. Laser designed to focus at distance.

Propagation. Various portions of the electromagnetic spectrum propagate differently through various media. For example, microwaves go through brown paper, but light will be absorbed or reflected by it. Water will absorb microwaves, but light will pass through it. Mirrors will reflect visible light, and the wire mesh in the door of a microwave oven will reflect microwaves. Thus, the ability of any particular wavelength/frequency to propagate its beam varies considerably from one part of the spectrum to another.

In addition, within a particular portion of the electromagnetic spectrum, there are vast differences in how well different frequencies will propagate through the atmosphere. These differences are highly specific--usually dependent upon the susceptibility of a frequency to being absorbed or defracted by particles and gases in the air.

Continuous wave and pulsed beams. There are two types of DEWs beams: continuous wave and repetitively pulsed. A continuous wave (CW) beam can place energy on the target in an uninterrupted manner. A repetitively pulsed beam has pauses between bursts of energy. An advantage of pulsed beams is that they have higher peak power thereby causing shock waves as well as thermal energy. Figure 5 is a representation of a continuous wave beam and several variations of pulsed beams. The variations of a pulsed beam include whether it is a single or multiple pulsed beam, whether the pulses are of high or low frequency, and whether the beam pulse is of long or short duration.

It is evident from the chart that to determine the total amount of energy on a target, it is necessary for the following to be known:

- o total exposure time
- o frequency of pulses
- o length of duration for each pulse
- o peak power for each pulse or average power for CW.

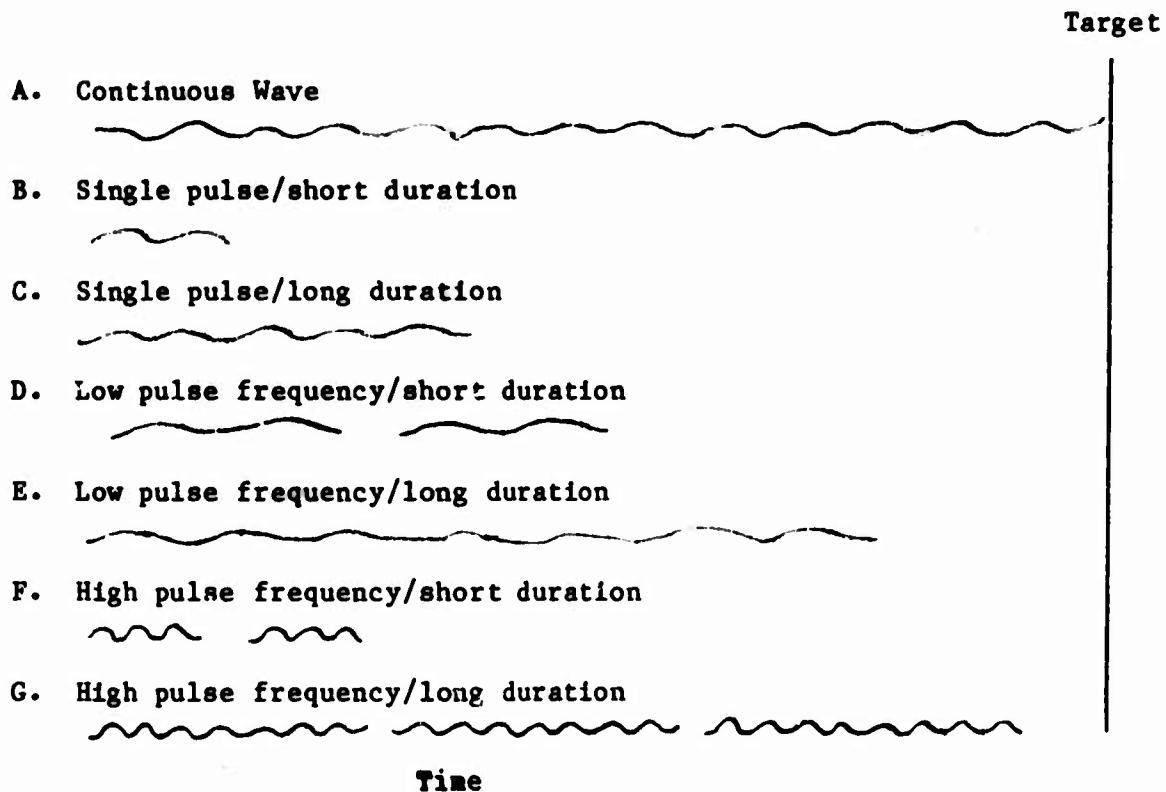

Figure 5. Continuous wave and repetitively pulsed beams.

BIOEFFECTS OF LASERS¹

Personnel

The hazard for personnel who have been exposed (irradiated) to laser radiation is dependent in large part upon the wavelength of the radiation, the beam intensity, and the exposure time. The wavelength of the beam determines the penetrating ability of the radiation while the beam intensity (irradiance or fluence) is a measure of the level of energy (heat) deposited on the target. The danger to the individual soldier results from direct or reflected exposure to laser radiation which could ignite the soldier's clothing or damage his unprotected skin or eyes. For low energy lasers, the hazard is primarily related to the eyes. For high energy lasers, however, the soldier's clothing could burst into flames, his skin could be burned severely, and/or his eyes blinded permanently.

¹Reproduced from the Capstone Manual (1982, pp.3-74 through 3-89). The tables and figures have been renumbered to maintain an orderly sequence in the present report.

Also of concern is the fact that the irradiation from high energy levels are sufficient to ignite most combustible materials with ease. Therefore, even the environment around a well-concealed and protected soldier, such as trees, bushes, logs, and wooden structures, is susceptible to being ignited and can place the soldier in grave danger.

Although the eye is the organ most sensitive to damage by laser radiation, effects on the skin are also of concern. Numerous experiments have been conducted to determine damage thresholds as a result of laser radiation exposure. The complexities of eye damage require special attention and will come from experiments with animals. If the temperature of human skin is raised above 45 degrees C (113 degrees F), severe pain will result. Skin injury resulting from momentary, but very intense heat exposures, are termed "flash burns." Table 2 shows the level of intensity required to produce burns on an exposed 2 cm² patch of skin.

Table 2

Burn Thresholds for Skin

Degree of Burn	Irradiance Required*	Result
First-Degree	12 w/cm ²	Reddening Sunburn
Second-Degree	24 w/cm ²	Blistering
Third-Degree	34 w/cm ²	Skin (Epidermis) is Destroyed

*Note: w/cm² is watts per square centimeter.

While the exposure levels in Table 2 were achieved by intense, 0.5 second duration, white light (carbon arc source), they could also be achieved by many high-powered lasers at extended ranges.

The size of the skin area exposed is an important factor in determining damage thresholds. For a small area of irradiated skin tissue (1mm²), the heat conduction is far greater and would permit higher dosage levels. However, if the entire body is irradiated, a far lower level of radiation would cause injury. The effect the laser has on the skin is to deposit energy in the form of heat. If the energy is deposited slowly or at very low levels of irradiance (measured in watts/cm²), there is little danger of injury. It becomes a question of how fast the skin and surrounding body tissue (and the atmosphere) can dissipate the heat before damage-threshold temperatures are reached or exceeded.

Other factors that influence the damage threshold include the time or period of exposure, the depth of radiation penetration, and the reflectance of the skin.

Exposure Duration. As the exposure duration decreases, the irradiance required for an injury increases significantly. For the example given above, where a 0.5 second exposure to white light having an irradiance of 34 w/cm^2 , caused third-degree burns, a similar effect can be obtained in approximately 60 seconds with an irradiance of 0.9 w/cm^2 . Exposure times to laser light are considerably reduced because of the penetrating power of laser radiation. In effect, the thermal injury produced is a function of the energy absorbed per unit volume (or mass) of tissue.

Depth of Penetration. The deeper the radiation penetrates, the higher the level of irradiance required to produce damage. Figure 6 shows schematically the penetration depth of different laser wavelengths.

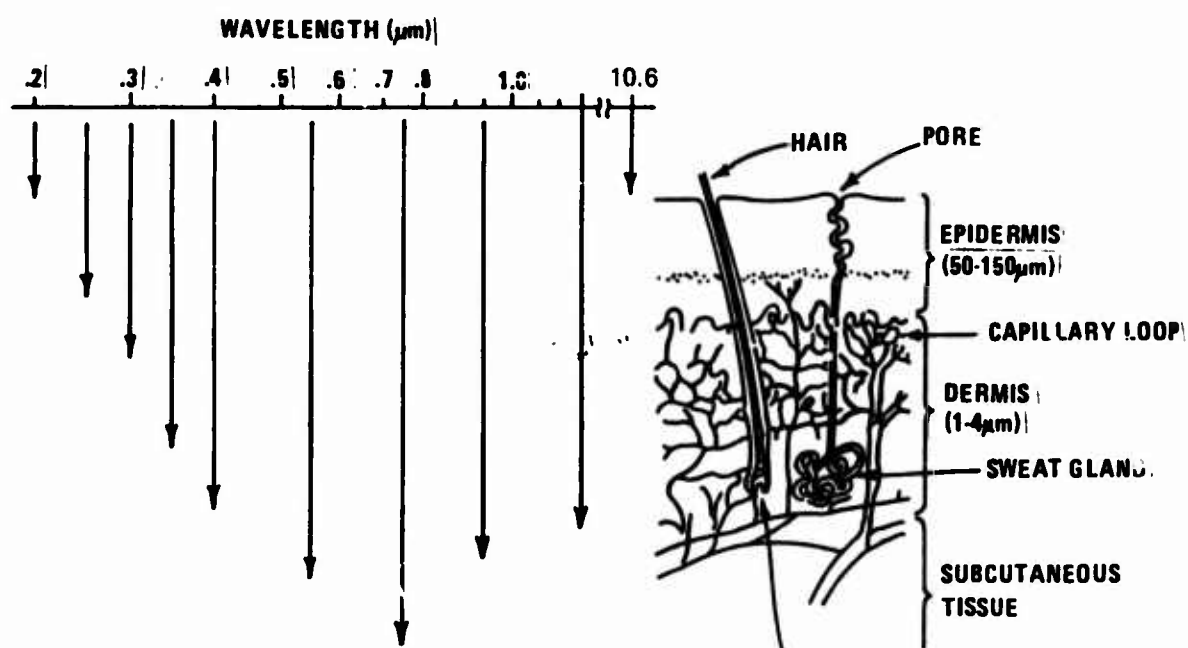

Figure 6. Depth of penetration into the skin for different wavelengths.

It is apparent from Figure 6 that a CO_2 laser ($10.6 \mu\text{m}$) penetrates only to shallow skin tissue, whereas the Nd:YAG ($1.064 \mu\text{m}$) penetrates well into the skin tissue (into the dermis) before being absorbed. Consequently, given equal levels of irradiance for the CO_2 and Nd:YAG lasers, the CO_2 laser would produce damage much more rapidly.

Reflection. The reflectance of the skin plays an important role in determining how much radiation is effectively absorbed. Varieties of pigmentation affect the ability of the skin to reflect radiation of the visible and near-infrared spectrum. The skin's ability to reflect electromagnetic radiation is shown in Figure 7. Much of the radiation in the visible and infrared regions are reflected. Whereas nearly 40% of the radiation from a Nd:YAG ($1.064 \mu\text{m}$) is reflected from most skin surfaces, only 4% of a CO_2 ($10.6 \mu\text{m}$) laser beam would be reflected. [Light skinned individuals can be expected to suffer less effects than dark skinned individuals.]

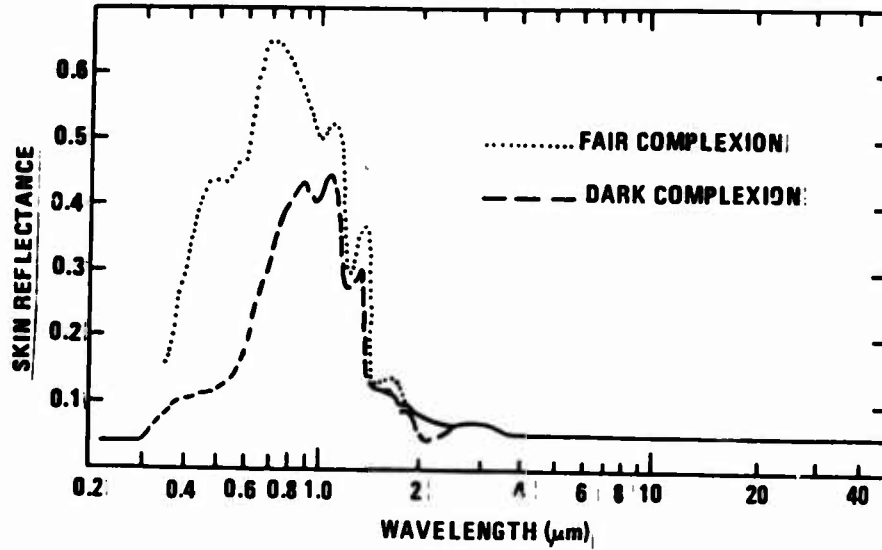

Figure 7. Radiation reflectance of human skin.

Skin damage as a result of laser radiation can vary from no effects; to mild reddening; to a black, charred, deep burn. Different laser wavelengths produce different effects. Aside from the wavelength of the laser, other characteristics of the laser affect the level of damage. They are the mode of operation (CW, pulsed, repetitively pulsed, Q-switched, mode locked, etc.), the exposure time, and the irradiance level. Table 3 gives the thresholds for skin damage using a variety of lasers.

Table 3

Laser Threshold for Skin Damage

Type Laser	Operating Mode	Wavelength (μm)	Exposure Time (S)	Irradiance (J/cm ²)
Ruby	Normal pulse mode	.6943	2.5x10 ⁻³	2.2
	Q-switched pulse	.6943	75x10 ⁻⁹	.25
Argon	Shuttered pulse	.488	1.0	4.0
CO ₂	Shuttered pulse	10.6	1.0	2.8
Nd:Glass	Q-switch	1.06	75x10 ⁻⁹	2.6
Nd:YAG	CW	1.064	1.0	46

It is apparent from the above table that fast-pulsed lasers are considerably more hazardous than CW lasers.

The Human Eye

The Structure of the Eye. The adult human eye is roughly the size of a 25-cent U.S. coin (approximately 25mm) in diameter. A simplified cross-section of the human eye is illustrated in Figure 8.

1. The Cornea - The cornea of the eye is exposed directly to environmental elements. It is protected from drying out by a thin tear film. The living tissue of the cornea is renewed continually, with the normal cell having a lifetime of 48 hours. For this reason, corneal cells have the highest metabolic rates in the entire body. The cornea is transparent to electromagnetic radiation ranging from 0.4 to 1.2 μm .

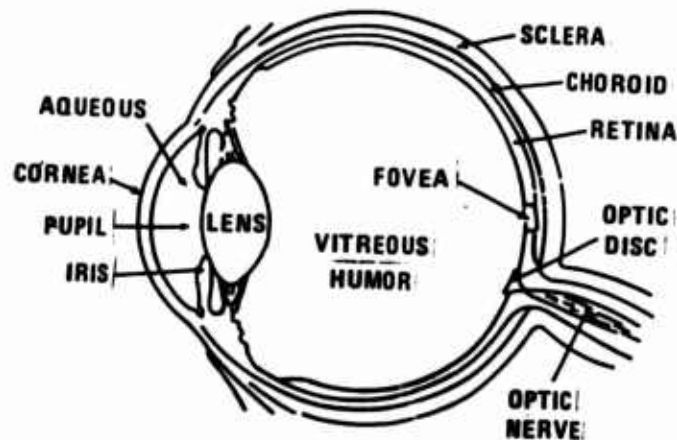

Figure 8. Cross-section of the human eye.

2. The Aqueous - The aqueous is essentially water and serves as a heat-absorbing filter, protecting the lens from far and intermediate infrared thermal radiation.

3. The Iris - The iris is a layer of muscular tissue that adjusts the pupil of the eye. The size of the pupil varies from two to seven millimeters depending upon the average brightness in the field of view.

4. The Lens - The lens, which has a crystalline, semiplastic character, focuses the images entering the eye on the retina.

5. The Vitreous Humor - The vitreous humor is a colorless gel material that fills the bulk of the eye chamber. It is attached to the retina and can damage the retina if it shrinks from old age or through the trauma associated with contact with blood.

6. The Retina - The retina is the lining on the posterior portion of the eye and consists of several very complex layers of nerve cells. In effect, it is an extension of the brain. Two types of photoreceptor cells, called rods

and cones, line the retina and are responsible for detecting images and variations in color and light intensity.

7. The Choroid - The choroid is an extremely vascular spongy tissue that is separated from the retina by a thin membrane and surrounds the posterior portion of the eye. The blood vessels in the choroid are very large and are the cause of bleeding in the eye as a result of over-exposure to laser radiation.

8. The Sclera - The sclera is a dense fibrous shell that is roughly spherical in shape. It blends with the cornea in the front of the eye. The sclera helps maintain the rigidity of the eyeball.

9. The Fovea - The fovea is a depression in the retina (devoid of blood vessels), where vision is the clearest and the best color definition is achieved. The fovea has the highest concentration of cone receptors and is in a region free of rods.

Sensitivity of the Eye to Light

The sensitivity or vulnerability of the eye to laser radiation, as with any optical or electro-optical system, is determined largely by whether the radiation is in-band or out-of-band to the optical system.

Although the visual response of the eye is limited largely to wavelengths between 0.4 μm and 0.7 μm , there is some sensitivity of the retina to near ultraviolet and near infrared radiation. The ability of the eye to transmit electromagnetic radiation to the retina is illustrated in Figure 9. The spectral band from 0.4 μm to 1.4 μm is often called the retinal hazard region. Only radiation within this band will reach the retina. All other wavelengths are absorbed in or near the cornea and are therefore out-of-band.

In-band radiation is considerably more dangerous to the eye than out-of-band radiation because much less irradiation is required to produce damage.

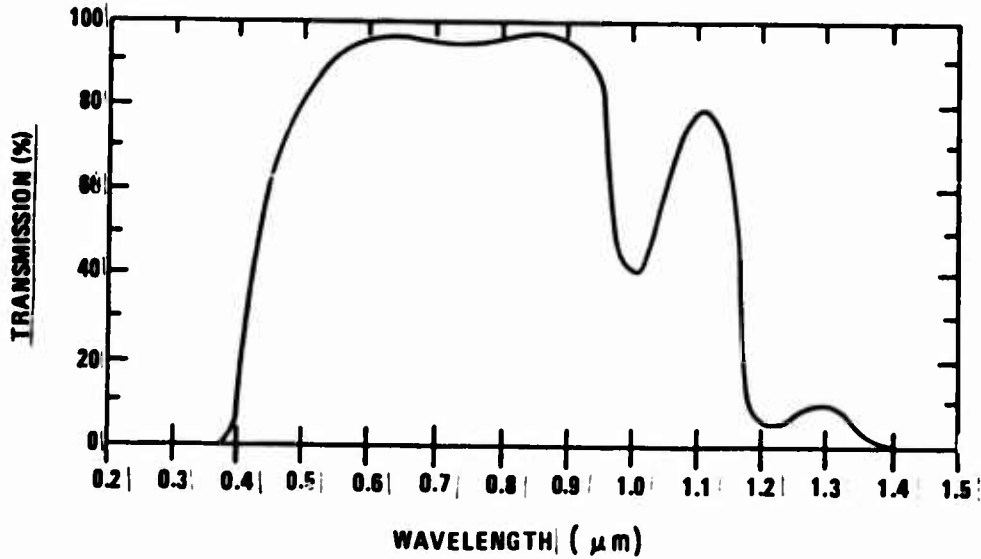

Figure 9. Transmission of light waves in the human eye.

The eye's function of focusing light rays onto the retina serves to magnify the intensity of the collimated light in the laser beam. As illustrated in Figure 10, a 1-watt visible laser beam represents a far greater hazard to the retina than a 100-watt light bulb.

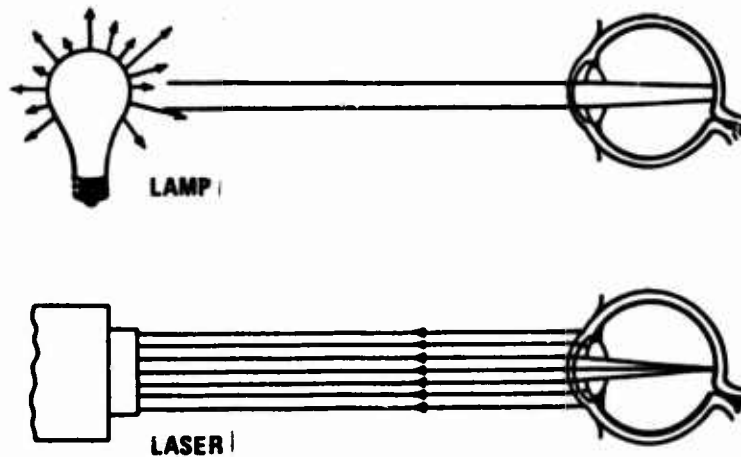

Figure 10. Effects of light on the eye.

The brightness of the collimated beam is more than one billion times greater than the light bulb. The focusing effect of the eye on a collimated beam produces an image on the retina that is extremely small. The same effect

can be achieved by using a magnifying glass to focus the rays of the sun on a piece of paper. The paper is set ablaze easily in the same manner that the retina is burned by concentrated radiant power from a laser beam.

Rods play the major role in night vision and are responsible for the eye's ability to respond to very low light levels. A single flash of less than 100 photons can be seen by the human eye. The peak wavelength for visual response is approximately 0.5 μm for night vision and 0.55 μm for day vision. Figure 11 shows the variations in night and day vision as a function of the wavelength of the light entering the eye.

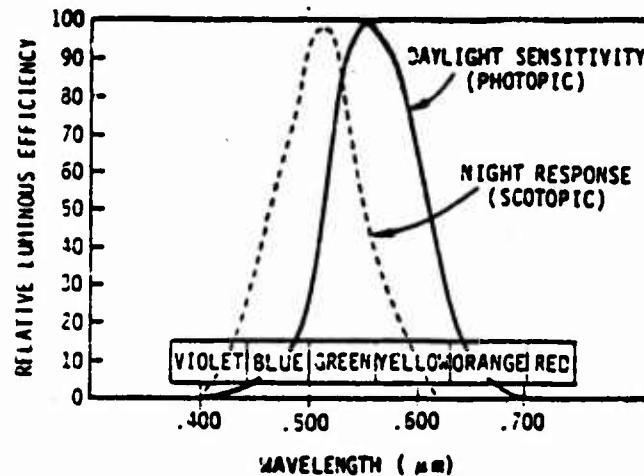

Figure 11. Night and day responses for the eye.

Laser irradiation of the eye can produce a range of damage and reduced vision effects. Damage may be slight and temporary in one instance or cause permanent blinding by destroying the optic nerve in another instance. Between these extremes, a large number of effects can be produced that affect the ability of personnel to perform military tasks. Among these effects are:

Hemorrhagic lesions - Characterized by severe retinal burns with bleeding and immediate loss of vision. It can be permanently blinding.

Temporary blinding - Produces intermediate retinal burns and degradation of visual acuity (sharpness of vision). Primary effects last from minutes to several days.

Minimal lesions - Characterized by minor retinal burns and dark spots in the individual's field of view.

Flashblindness - A temporary degradation of visual activity resulting from a brief but intense exposure to visible radiation. Recovery times range from a

few seconds to a few minutes. Hemorrhagic lesions, temporary blinding, and flashblinding could have a serious impact on mission performance.

The following account highlights the dramatic effects that laser irradiation can have on the human eye. Dr. C. David Decker, a highly skilled laser scientist, was partially blinded by the reflection from a relatively weak Nd:YAG laser beam. Permanent retinal damage resulted from a 6-millijoule, 10-nanosecond pulse of reflected invisible 1.064 micrometer radiation. Dr. Decker's description of the accident is recounted below:

When the beam struck my eye I heard a distinct popping sound, caused by a laser-induced explosion at the back of my eyeball. My vision was obscured almost immediately by streams of blood floating in the vitreous humor, and by what appeared to be particulate matter suspended in the vitreous humor. It was like viewing the world through a round fishbowl full of glycerol into which a quart of blood and a handfull of black pepper have been partially mixed. There was local pain within a few minutes of the accident, but it did not become excruciating. The most immediate response after such an accident is horror. As a Vietnam War veteran, I have seen several terrible scenes of human carnage, but none affected me more than viewing the world through by blood filled eyeball. In the aftermath of the accident I went into shock, as is typical in personal injury accidents.

The effects of optical radiation on the eye vary significantly with wavelength. The absorption of electromagnetic radiation in the eye is depicted in Figure 12. As shown in (a), microwaves and gamma rays pass through the eye. Far ultraviolet and far infrared (b) are absorbed in the cornea and represent out-of-band radiation. Near ultraviolet rays (c) are absorbed by the cornea, iris, and lens of the eye, while visible and near-infrared (d) radiation are transmitted to, and focused on, the retina (in-band radiation). In-band radiation ($0.4 \mu\text{m}$ to $1.4 \mu\text{m}$) can damage the retina, while out-of-band radiation (less than $0.4 \mu\text{m}$ or greater than $1.4 \mu\text{m}$) is generally absorbed in or near the cornea and can damage that portion of the eye only. The absorption of ultraviolet light rays by portions of the eye is shown in Figure 13.

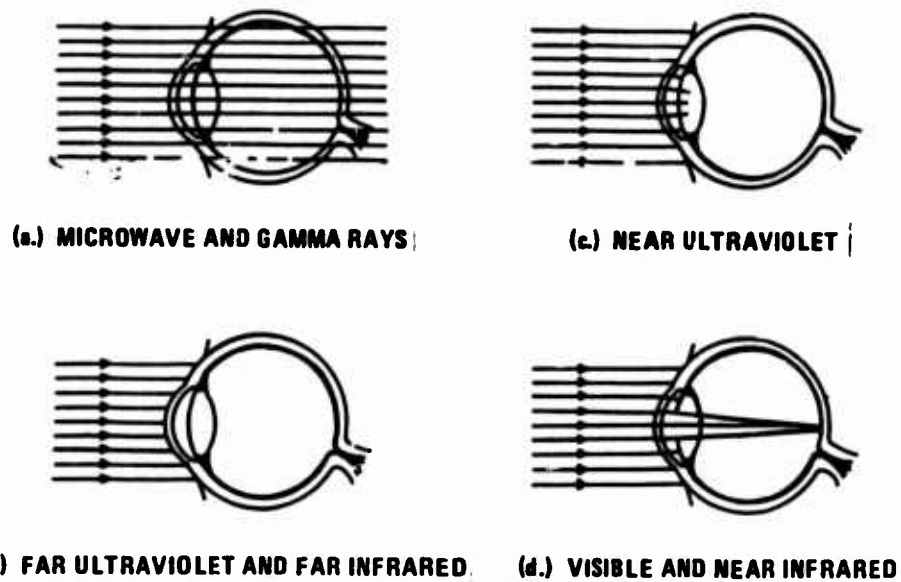

Figure 12. Absorption of electromagnetic radiation in the eye.

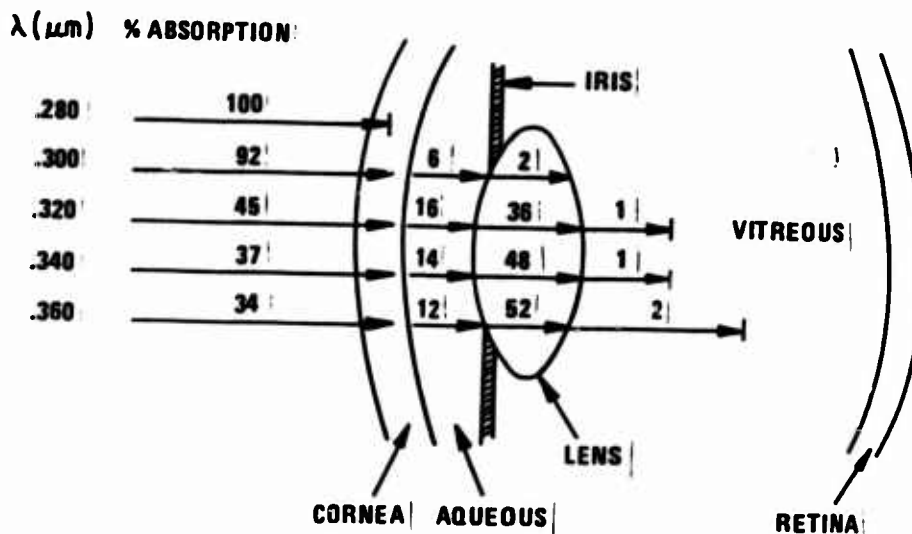

Figure 13. Absorption of near ultraviolet radiation in the eye.

Direct laser radiation is only one of three types of laser radiation hazards to the eye. In combat, direct radiation should be expected. The second hazard is specular reflection. This occurs when the laser radiation is reflected from a shiny, highly polished surface, such as a mirror or a piece of glass or the inside of a tin can. The third hazard is diffuse reflection, where the soldier receives a reflection, not from a polished surface, but from an object like a wall or tree. Types of reflections are illustrated in Figure 14.

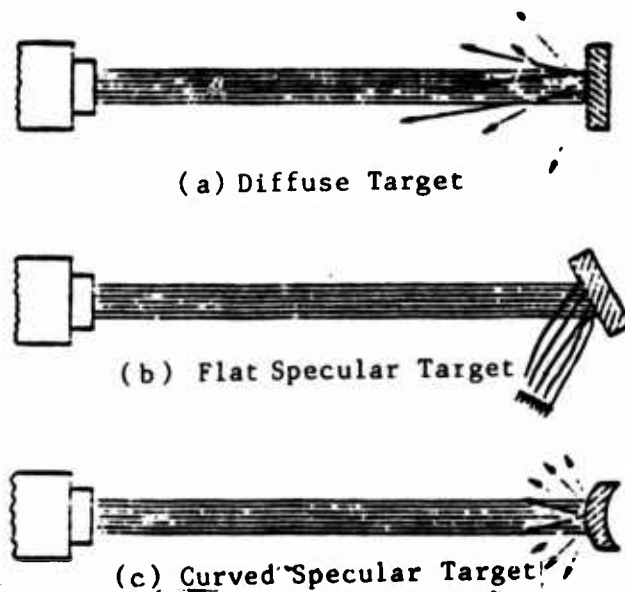

Figure 14. Types of laser reflection.

Three general categories of reflections are shown in Figure 14. Diffuse reflections (a) are generally not hazardous since the collimated nature of the beam is destroyed. Specular reflections, however, are most dangerous since the beam's collimation (b) or point-source (c) character is retained. The eye damage suffered by Dr. David Decker, who was quoted above, was done by a reflected laser beam.

The following account of an incident that took place in Los Angeles in October, 1981, underlines the danger of reflected laser light. A laser scientist, who was testing his newly purchased argon laser in his backyard, directed the beam toward a police helicopter flying nearby. The two policemen were flash-blinded, even though only one looked in the direction of the laser beam. The cockpit was illuminated by laser light reflecting off the glass and polished surfaces. One of the policemen said, "I thought the flash was caused by an on-board explosion I hadn't heard and that we'd just bought the farm." His flash-blinded condition lasted for approximately 20 seconds.

The Letterman Army Institute of Research has postulated the following scenario involving the use of high energy lasers (HEL). Consider the high energy carbon dioxide laser that produces an average power of 200 kilowatts operating at a pulse repetition frequency of 20 pulses per second. The energy emitted in each pulse is 10 kilojoules. These capabilities are well within the current state-of-the-art. The radiant exposure for a one second emission duration and the average beam diameter have been calculated and are shown in

Table 4 for ranges from 1.5 km to 6.0 km. The calculations are based on an assumption of a clear day, and include considerations of blooming, jitter, and turbulence.

Table 4

HEL Propagation Characteristics For One Second Exposure Time

Range (km)	1.5	3.0	4.5	6.0
Beam Diameter (cm)	12	28	49	68
Fluence (J/cm ²)	1000	200	57.5	24.7

Notice that the beam diameter at 3 km is 28 cm or approximately 12 inches. With a beam diameter of this size, the exposed area, and subsequently, the burned area, could include the entire face as well as the eyes. The doses of radiation (one second continuous wave exposure) required to produce acute biological damage to the skin and cornea are shown in Table 5.

Table 5

HEL Biological Effects From One Second Exposure

Effect	Fluence Required
Cutting with CO ₂ Laser Surgical Knife	80 kJ/cm ²
Immediate Charring of Skin Tissue	20 J/cm ²
Immediate Blistering	7.8 J/cm ²
Permanent Corneal Scarring	8 J/cm ²

At ranges out to 6 km, blistering and charring of the surface skin tissue and severe corneal burns can be anticipated for an exposure of only one second in duration.

Now consider the radiant exposure from a single pulse in the 20 pulse per second train emitted by the high energy CO₂ laser described above. The fluence per pulse is given in Table 6.

It is important to note that the single pulse fluence needed to completely destroy the corneal tissue as well as the outer layer of skin (epidermis) is only .2 J/cm². At a range of 4.5 km, where the beam diameter is approximately 0.5 meter, the biological effect on personnel is devastating. A soldier exposed to pulsed HEL radiation at this range could not complete his mission and would require immediate medical attention. HEL radiation is a serious personnel hazard at significant ranges.

Table 6

HEL Propagation Characteristics Per Pulse

Range (km)	1.5	3.0	4.5	6.0
Beam Diameter (cm)	12	28	49	68
Fluence (J/cm ²)	50	10	2.9	0.8

Other hazards exist to personnel who work near HELs in the form of toxic chemicals, electrical power generating equipment, and radio frequency radiation.

OPTICAL SYSTEMS OF THE BFV

All the optical systems of the BFV are described in this section. Readers who are already familiar with the BFV optical systems may wish to proceed directly to the next section which details how these systems interact with lasers and suggests potential field expedient countermeasures.

Non-Magnifying Optics

Eye-glasses and Contact Lenses. Eye-glasses and contact lenses are worn by personnel who need to correct their vision. It is estimated that 20% of the BFV personnel require vision correction; this compares to about 45% Army-wide. The reason for this difference is that most BFV personnel are generally younger, and younger persons do not suffer as much from vision problems as do older persons (C. Johnston, personal communication, Jan., 1984).

Unity Window of the Integrated Sight Unit (ISU). The unity window of the ISU provides the gunner with an unmagnified view. Light comes down the periscope of the ISU via mirrors and is directed out the unity window.

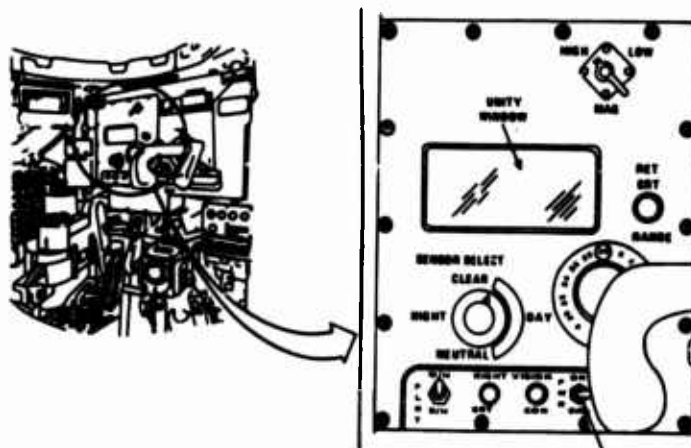

Figure 15. Diagram of unity window.

Sun, Wind, and Dust Goggles. There are two sets of sun, wind, and dust goggles issued to the BFV commander and the driver. These are worn during inclement weather and are lightly filtered to provide protection against bright sunlight.

Vision Blocks. There are 10 vision blocks on the turret and 11 on the body of the BFV. The BFV commander has eight vision blocks, the gunner two, the driver four; two are mounted on the left and right sides of the BFV, and three face to the rear of the BFV. All of these provide a port of entry for potential laser radiation.

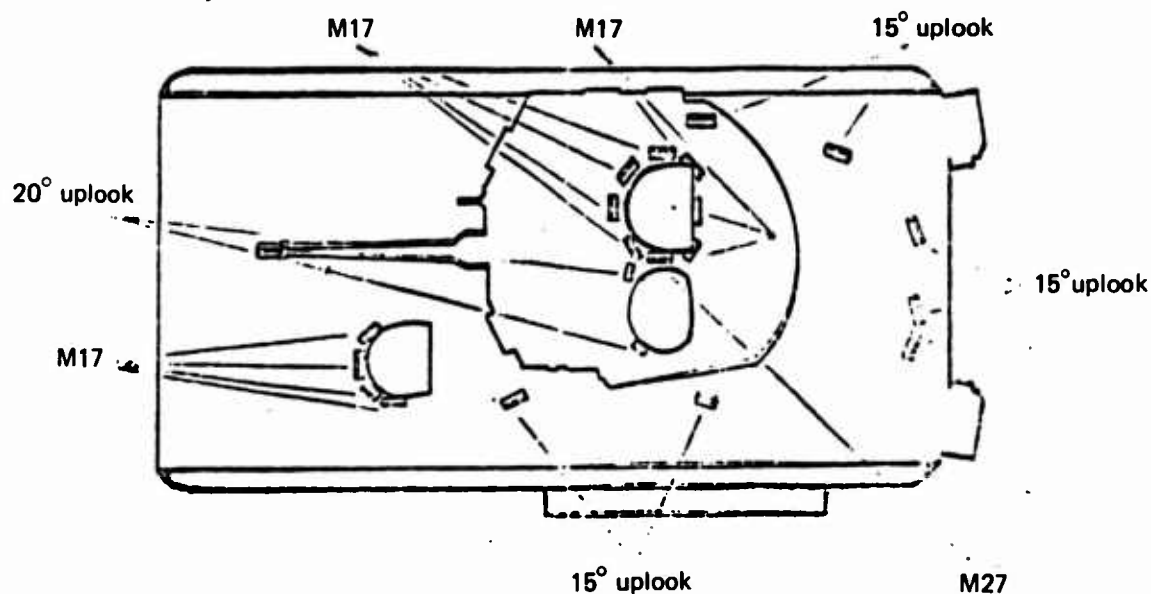

Figure 16. Vision block and periscope locations on BFV.

The three types of periscope used as vision blocks in the BFV are the M17, M17 (Uplooks), and the M27. These periscopes are made of glass and contain mirrors which redirect light down the optical train to the soldier's eyes. Also, each periscope has a blackout cover located on the interior of the BFV.

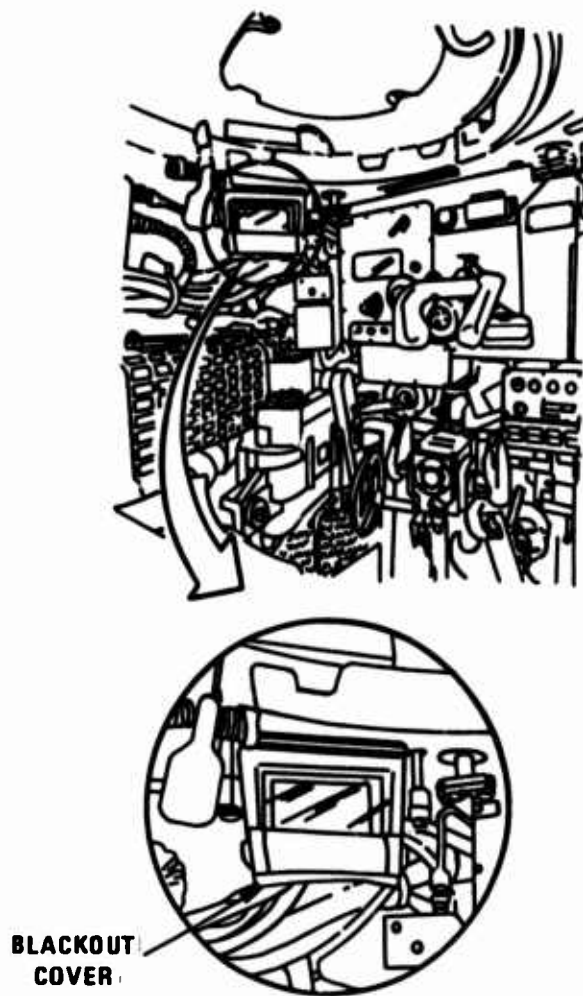

Figure 17. Blackout cover.

Magnifying Optics

The platoon headquarters is issued two sets of 7 power 50mm binoculars used by the platoon leader and platoon sergeant. Each squad is also issued one set. The M17 binoculars are used to acquire long range targets and to extend the range of the naked eye at night by taking advantage of the existing light. The day sight of the ISU has a 4 power magnification for target acquisition and a 12 power magnification for target tracking and firing of the TOW. The magnification is mechanically selectable by the gunner. The back-up sight with a 4 power optic is used as a back-up to the ISU and is a product improvement

not found on the earlier models of the BFV. Finally, each BFV squad is issued a Dragon Tracker which has a 6 power direct view optic. It is used to acquire targets for the Dragon.

AN/PVS-4 Individual-Served Weapons Night Vision Sight

The AN/PVS-4 is a small, lightweight image intensification device used on the M16A1 rifle and the M60 machinegun. It weighs 3.7 pounds and has a range of 400 meters in starlight and 600 meters in moonlight. It is powered by a 2.7 volt battery with a battery life of 10 hours and has a 3.8 power telescopic device used to provide increased weapon accuracy at night. Also, it can be used as a handheld night observation device to search, detect, identify, and observe friendly and enemy operations.

Two AN/PVS-4s are issued per squad. Dismounted squads can mount one AN/PVS-4 on the M60 machinegun and the other on an M16A1 rifle. The squad or platoon leader can also choose to use the AN/PVS-4 as a handheld night observation scanning device. Or the AN/PVS-4 can be taken to an observation post to provide a night observation capability. In general, the use of the device is controlled by the squad or platoon leader.



Figure 18. AN/PVS-4 individual-served weapons night vision sight.

The AN/PVS-4 comes with a daylight lens cover. This cover has three sets of holes of different sizes on the outside of the cover and has two sets of openings on the inside cover. The inside cover has six opening; three are large openings (approximately 6mm) with filtered glass, and three are small openings. By rotating the outside portion of the lens cover relative to the inside portion, six different combinations of settings can be used to regulate the amount of light entering the PVS-4 during daylight conditions. At night the PVS-4 is used without the lens cover.



Figure 19. AN/PVS-4 daylight cover.

AN/PVS-5 Night Vision Goggles

The AN/PVS-5 is a lightweight, battery powered (2.7 volt), passive or active night vision device worn on the head. The battery life is 10 hours. It weighs 1.9 pounds and has a range of 150 meters in the passive mode. One set of goggles is issued per vehicle and is usually worn by the vehicle commander. By using the AN/PVS-5 while moving, the vehicle commander has almost the same night vision capability as the driver. The AN/PVS-5 helps the BFV commander control the movement of the vehicle as it travels at night on roads or cross country. The AN/PVS-5 has a built-in active infrared light source which can be used to provide added illumination for close-up viewing within two meters. In this mode, the night vision sight can be used to read maps, overlays, or orders. It is important that the active mode be shielded from possible enemy detection. It is best to limit the use of this mode to inside a building, a vehicle, under a poncho, or any place where there is not a direct line of sight from the infrared light source to the enemy. The AN/PVS-5 can be used for vehicle maintenance during darkness and can be worn by a ground guide to direct the M2 Bradley Fighting Vehicle. It can also be used by the driver as a backup system to the AN/VVS-2.



Figure 20. AN/PVS-5 night vision goggles.

AN/VVS-2 Driver's Night Viewer

The AN/VVS-2 is an image intensification device. It allows the vehicle driver to see well enough to move the BFV during darkness. It is mounted in the center periscope position of the driver's station. The center periscope is

stowed in the AN/VVS-2s stowage space on the left side of the driver's compartment. Without placing his face against the eyepiece, the driver is able to use both eyes to view through one large diameter eyepiece of the AN/VVS-2. Night road marches can be conducted at speeds up to 50 kmph. At night, the driver is also able to track rounds for the gunner with the AN/VVS-2 if the target is to the left front of the vehicle. The AN/VVS-2 can be rotated 30 degrees to the right or left and has a range in excess of 150 meters. This gives the driver a field of view 115 meters wide at 150 meters. Rounds fired from the 25mm gun and the 7.62mm coaxial machinegun can be observed out to greater ranges. The AN/VVS-2 is powered by the vehicle electrical system or by use of a 2.7-volt battery.



Figure 21. AN/VVS-2 driver's night viewer.

Thermal Devices

Thermal devices work differently from image intensifiers. Thermal devices are sensitive to the 8 - 14 μm portion of the electromagnetic spectrum (the far-IR region). Some new thermal devices are sensitive to 3 μm to 5 μm but these are not found in the BFV squad at this time. The 8 - 14 μm waveband was chosen because energy in this wavelength can penetrate many types of battlefield obscurants such as smoke, fog, dust, camouflage, and light vegetation. Another characteristic of thermal devices is that they require their detectors to be cooled to very low temperatures (around -380 degrees F) in order to detect the incoming IR and to reduce the effects of random thermal noise.

There are two thermal devices used in the BFV platoon: the AN/TAS-5 Dragon thermal night vision sight and the night site of the ISU.

AN/TAS-5 Thermal Sight. The AN/TAS-5 is a battery-powered passive, thermal imagery system. The AN/TAS-5 is issued one per Dragon daysight tracker (thus three per platoon) for the antiarmor specialist to use at night. The AN/TAS-5 detects and displays on a screen thermal energy that is emitted by all objects, manmade or otherwise. It weighs 20.6 pounds and has a range of 1,000 to 1,200 meters. The AN/TAS-5 uses rechargeable batteries and employs small gas bottles for cooling the detector electronics. These batteries and cooling bottles have a lifetime of two hours. The AN/TAS-5 should only be used to acquire and engage targets and not be used as a surveillance device in order not to wear down the battery; other night vision devices are used for surveillance. When a target is detected, the gunner is alerted and uses the AN/TAS-5 to acquire and engage the target. A cool-down period of 10 to 15 seconds is required to activate the sight before it can be used effectively.

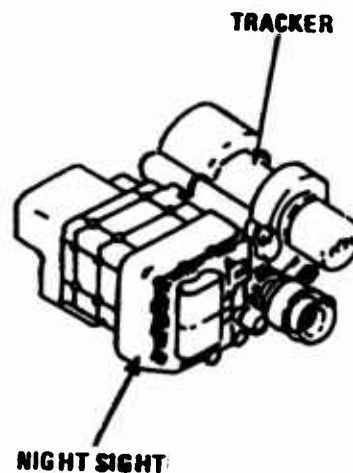

Figure 22. AN/TAS-5 thermal sight.

Thermal Sight of the Integrated Sight Unit (ISU). The thermal sight is an integral part of the ISU. It has both a 4 power and 12 power magnification. When a target is acquired by the 4 power magnification, the sight is then switched to the 12 power magnification for target engagement. The ISU displays the same image to both the gunner and the commander and requires a 10-minute cool down period before targets can be detected.

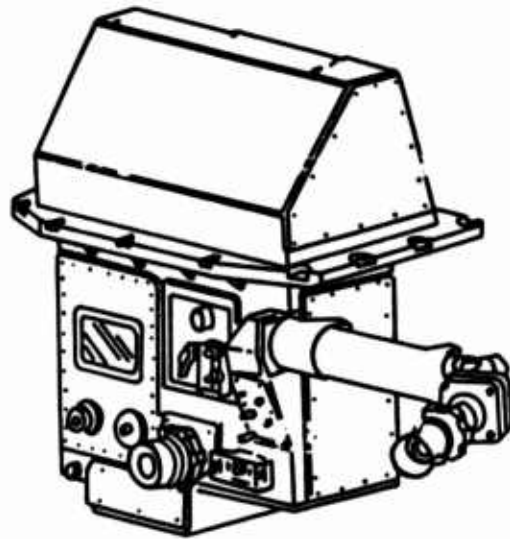

Figure 23. Integrated sight unit (ISU).

TOW IR Tracker

The TOW missile employs a near-IR beacon which is pointed aft toward the launcher on the BFV turret when the missile is in flight toward the target. This beacon is modulated to provide discrimination between the missile and a high background emitter such as the sun or a laser jammer. The ISU provides a means of detecting and tracking the missile beacon in the near-IR thereby providing an output signal representative of the missile position with respect to the turret-to-target line of sight of the error detector for TOW guidance.

OPTICAL SYSTEMS OF THE BFV, LASERS AND FIELD EXPEDIENT COUNTERMEASURES

The optical and electro-optical (OEO) systems in a BFV platoon (see Optical Systems of the BFV) can be grouped into five classes for the purpose of evaluating how each interact with laser:

1. Non-Magnifying Optics

- o corrective lenses (regular eyeglasses)
- o contact lenses
- o unity window of the integrated sight
- o sun, wind, and dust goggles
- o vision blocks

2. Magnifying Optics

- o M17 Binoculars (7 power)
- o Daysight M47 (Dragon) Tracker (6 power)
- o Daysight Integrated Sight Unit Clear or Filter (4 and 12 power)
- o Backup Sight (4 power)

3. Image Intensification Devices

- o AN/PVS-4 Individual-Served Weapons Night Vision Sight
- o AN/PVS-5 Night Vision Goggles
- o AN/VVS-2 Night Vision Driver's Viewer

4. Thermal Devices

- o Thermal Night Sight of the Integrated Sight Unit
- o AN/TAS-5 Dragon Thermal Night Vision Sight

5. Infrared Trackers

- o Infrared TOW Tracker
- o Infrared Dragon Tracker

Figure 23 shows where each class fits on the electromagnet spectrum. In addition, the Army is beginning to field a new generation of thermal devices which do not require cryogenic devices; these are included in Figure 23 for completeness.

In actuality, direct-view optics transmit a broader band than the .4 - .75 μm listed; the human eye perceives electromagnetic energy in the .4 to .75 μm band as visible light.

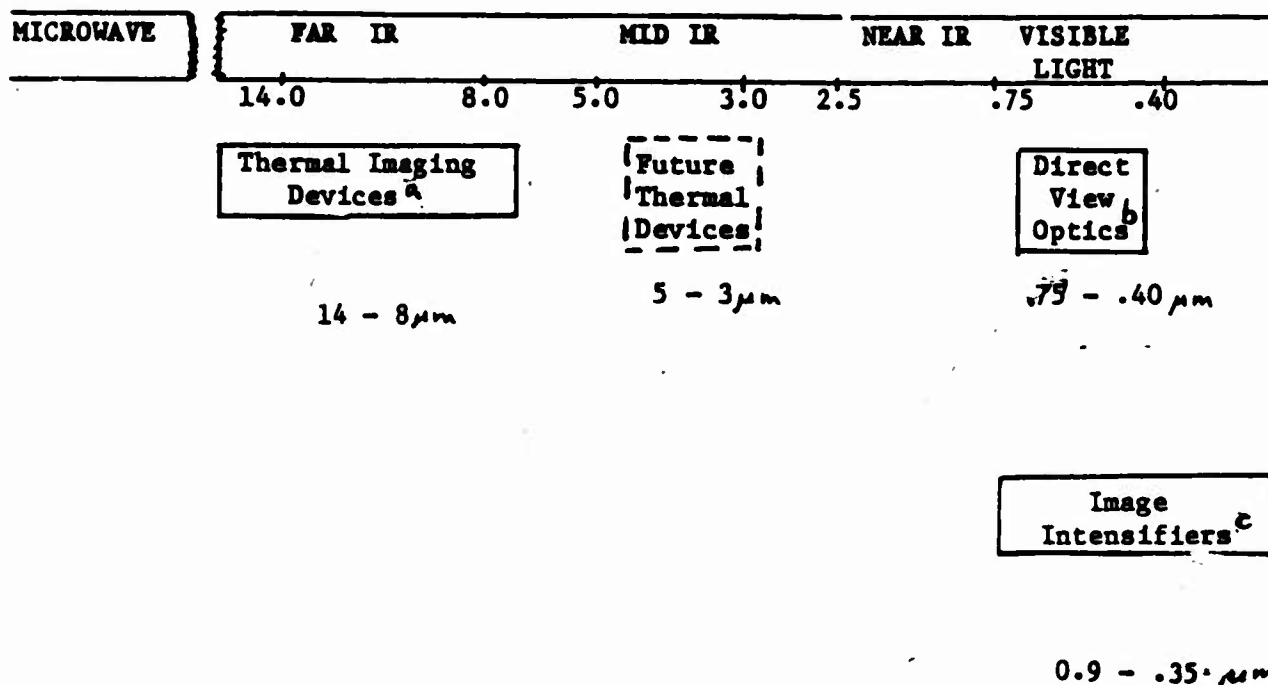

Note. The actual ranges of the image intensifiers and thermal devices on the BFV are a little less than those shown. The ranges shown are ranges for the different STANO devices in the Army, some of which are not found on the BFV.

^aAlso known as Forward Looking Infrared Reconnaissance (FLIR) and Far IR devices.

^bNon-magnifying and magnifying.

^cAlso known as I², near Infrared, and Infrared devices.

Figure 24. Electromagnetic spectrum utilized by BFV optical systems - wavelength in μm (millionths of a meter).

Direct-View Optics and Lasers

Laser light which is in-band to direct-view optics (.4 to .7 μm) passes directly through the system relatively unaffected by the glass. There will be some minor scattering or reflection of the light energy by the glass but this is generally negligible. Even clear eyeglasses will reduce the luminous transmittance (amount of light going through the system) by about 20%; however, this degradation is virtually unnoticeable to the naked eye. Thus lasers which are in-band to the direct-view optics are a definite threat to viewers using any of these direct-view systems. It must be noted that the filtering material on the sun, wind, and dust goggles is inadequate protection against in-band

laser hazards because it was developed to provide protection from only bright, noncoherent sunlight. This protection is several orders of magnitude lower than the protection needed to guard against a laser attack. Thus, soldiers must not be lulled into the false believe that these filters are sufficient for laser protection.

However, direct-view optics do provide protection to the human eye from laser light which is out-of-band to the direct-view optic because the laser light (e.g., CO₂, 10.6 μ m) will be absorbed by the first optical surface in the optical train. For example, in the case of the vision blocks, it would be the outside surface of the periscope. This is also true of the sun, wind, and dust goggles as well as any eyeglasses or contact lenses soldiers may be wearing. Consequently, soldiers wearing eyeglasses will have eye protection from laser energy which is out-of-band to their eyeglasses. However, soldiers without eyeglasses will be susceptible to corneal damage because the cornea, in this case, will be the first surface contacted and it will absorb the laser energy.

In addition, because laser light which is out-of-band to the human eye is invisible, the viewer may not even know he has been struck by a laser if it is a low-power laser. If a soldier looking through an optic were struck by a more powerful laser, the surface of the optic could heat up with a bright, visible flash due to molecules on the surface of the optic emitting photons in the visible light spectrum. If the laser were extremely powerful, it could deposit enough energy on the material to craze the surface, rendering it permanently useless. In this case, the crazing would look like the frosted surface of a shower door. If such a laser hits the naked eyes or someone wearing contact lenses, it could deposit enough energy on the cornea of the eyes or the contact lenses to burn them. Such an high energy level would also cause severe facial burns. However, it is unlikely that such a powerful laser weapon could be fielded for tactical employment in the near future due to the size of the equipment required to generate such power at tactical distances.

Another factor that should be considered is in-band light coming through the vision block which could strike surfaces on the inside of the vehicle and bounce around inside the BFV. If there is a shiny object on the inside, there is the danger that a reflection off that object could strike someone's eyes causing injury. The inside color of the BFV is a light green which may lend itself to reflection. The possible effects on personnel of laser light coming through the vision blocks are unknown; it may be appropriate to use a more light absorbing color than the current pale green color to protect against laser reflections. Some experts believe that once the light strikes the inside of a BFV, it would most likely hit a diffuse surface and dissipate the beam's energy in many directions. Thus, it would lose its intensity and should not present as great a hazard.

There is another possibility which should be given some consideration. Even with laser safety goggles on, light could strike from behind the head, reflect off the rear of the protective lens and into the eye of the soldier (see Figure 25). The likelihood of such an occurrence needs to be assessed.

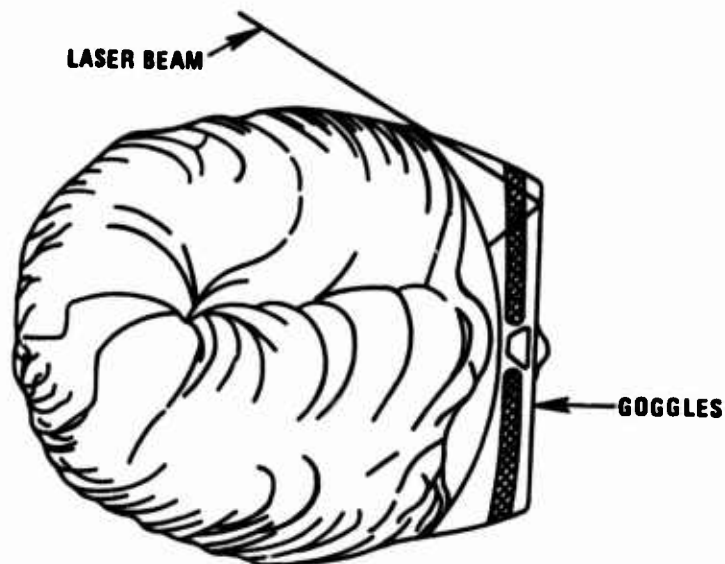

Figure 25. Light reflecting inside of safety goggles.

Field Expedient Countermeasures For Nonmagnifying Direct-View Optics

Vision Blocks. An obvious laser countermeasure would be to use blackout covers over the vision blocks. These would provide for sufficient protection against laser hazards. Unfortunately, this action would also completely obstruct the crew members view of the outside environment and thus defeat the purpose of vision blocks.

Through training, one could avoid having all the soldiers looking through vision blocks at the same time on the same side of the vehicle. For those who have to observe, a patch worn over one eye would protect at least the covered eye from laser injury. It is unrealistic to expect soldiers to keep one eye closed all the time because this is an unnatural process and fatigue rapidly occurs. Furthermore, during the heat of the battle, the soldier would always have to remember to keep his eye closed.

Under extreme circumstances, a soldier can put his hand over his eye and look through the small openings between his fingers. This cuts down on the total amount of light which reaches the eye. It is important to keep the opening as small as possible, certainly less than 7mm at night and 3mm during the day because that is the adaptive size of the pupil during these times. If larger holes were used, the soldier would lose any potential protection and it would be better not to use anything because he would not be degrading his visual capabilities by covering his eye.

Putting pin holes on tape and taping the vision blocks with the tape will greatly reduce the total amount of energy coming through. This would also reduce the amount of laser light that could strike reflective surfaces in the

interior of the vehicle and would protect other occupants in the vehicle from reflected light.

The previous procedure was attempted in a field trial, but it was found that a small hole significantly degrades the field of view. A better approach which affords similar protection but does not reduce the field of view nearly as much is to cover the interior glass of the vision block with tape leaving an opening about 3mm wide (the thickness of a stack of two quarters) across the length of the vision block.

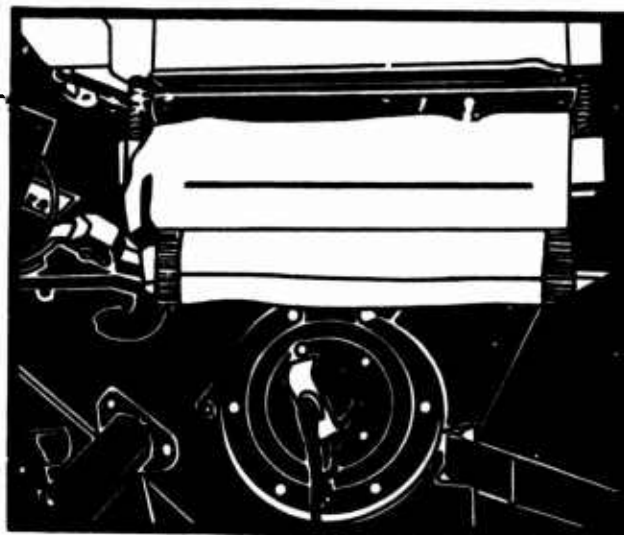

Figure 26. Tape on vision block with 3mm opening.

This revised procedure allows for a much wider field of view than pin holes, and when the head is moved up and down the view is nearly identical to an unmasked vision port. The protection this technique provides is twofold. First, it reduces by approximately 25% the total amount of laser energy entering the eye. Soldiers riding in a BFV have their eyes somewhat dark adapted thus a 6mm diameter pupil would have an approximate surface area of 28mm^2 . By looking through the 3mm opening the total exposed area of the pupil would be only 21mm^2 . Thus 25% of the laser energy would be avoided.

More importantly, there is the possibility the laser may not hit the eye at all because the eye may not be exactly aligned with the laser and the opening. Thus, the laser beam may harmlessly deposit the energy on the soldier's forehead or nose. If such is the case, the soldier may be able to detect the laser without being injured by observing the reflection of light off his skin. This would allow him to take appropriate countermeasures before an injury occurs.

For protection against a high energy laser which is out-of-band to the vision block and capable of crazing the glass, mounting a set of brackets containing some sacrificial glass would be an effective countermeasure. An obvious drawback of this procedure would be that once the vision port was crazed, it would not be usable until the sacrificial glass was replaced; but this is preferable to having the vision block itself crazed.

Unity Window of ISU. There is no blackout cover for the unity window. Protection could be gained by closing the exterior protective cover of the ISU, but this makes it impossible to fire the TOW because the protective cover must be opened to fire the TOW. A possibility which avoids this problem would be to put tape over the unity window which is located on the inside of the turret. Any type of tape which does not allow light through would suffice. Even coloring it with a marking pen would provide some protection.

Sun, Wind, and Dust Goggles. An excellent countermeasure is to cover the goggles with masking tape, leaving an approximately 3mm opening across the length of the goggles off axis to the eyes (Figure 27). The opening should be above the eyes (around the level of the eyebrows), or beneath the eyes (around the level of the upper lip). When the opening is placed off axis to the eyes, the user is forced to tilt his head to see the horizon. This is an uncomfortable position and soldiers will automatically bob their heads up or down to obtain their bearings and then return their heads to a more comfortable position. This action has several beneficial results:



PROTECTED FROM LASER



VIEWING

Figure 27. Tape on sun, wind, and dust goggles.

- o It limits the individual's vulnerability to that portion of time when he is tilting his head to look forward.
- o It takes advantage of human physiology by using fatigue as a reminder to keep one's eyes protected. This now becomes an automatic process; thus, the soldier does not have to be trained or reminded to do this.
- o Using masking tape (vs. electrical tape) would allow a soldier to detect lasing with an in-band laser and yet not be injured because he should be able to see the laser light through the tape. This may also give him a general idea where the laser weapon might be located.

Magnifying Optics and Lasers

The use of magnifying optics in a laser environment can be extremely dangerous because the optics focus the beam to a much smaller area and thereby concentrate the power of the beam. This, in turn, can cause so much energy to be placed on a surface that it will not be able to dissipate the energy fast enough. Thus the surface will begin to heat up and damage could occur. This process is identical to using a magnifying glass and sunlight to burn a hole in a leaf.

Magnifying optics increase the energy density of a laser beam by the square of the magnification power times the light transmission of the optic. For example, the M17 binoculars have a magnification of 7 and a light transmission of about 50 percent. The total increase in energy would be $7^2 = 49$ (the magnification squared), times 50 percent (light transmission) for a total energy density increase of 24.5. This means an individual would concentrate 24.5 times more energy using the binoculars than using his naked eye. This could very easily be the difference between being momentarily flashblinded and permanently blinded.

The increased hazard of using binoculars in a DEWs environment is illustrated in Figures 28, 29, and 30. These curves are comparable to currently fielded US laser rangefinders. The M1 uses 1.064 μm and the M60 uses the ruby .6943 μm rangefinder.

As can be seen in Figures 28 through 30, laser hazards exist on the battlefield today. A vitreal hemorrhage (inner eye bleeding) can occur around 200 to 250 meters for the naked eye during daytime from the rangefinder. With binoculars, inner eye bleeding can occur out to 2 kilometers. Thus, the danger of laser injury is dramatically increased out to tactically significant ranges.

It must be emphasized that these curves are for a single pulse rangefinder. Laser designators are multipulsed and can cause even more damage. Future laser weapons will be significantly more powerful than these laser designators.

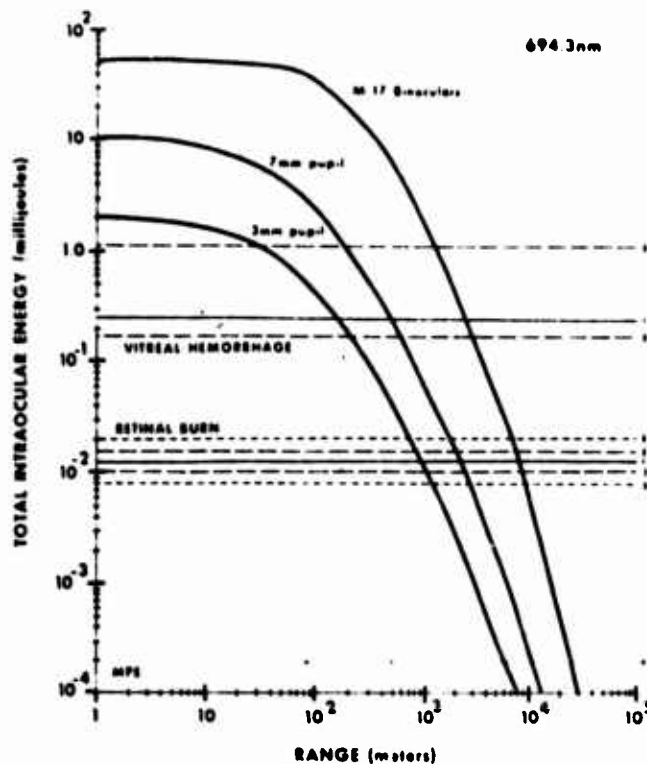
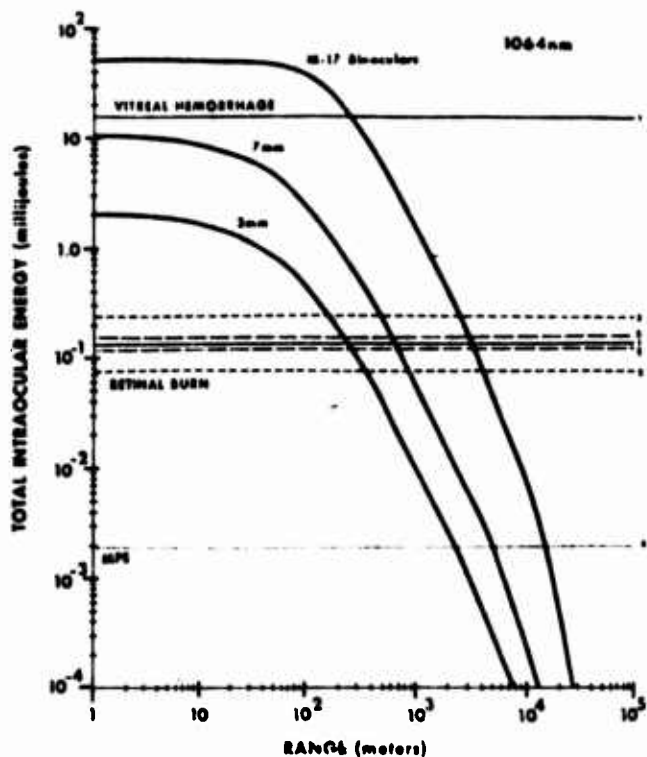

Figure 28* (upper left). A neodymium laser operating at a wavelength of 1.064 μm

Figure 29* (upper right). Ruby laser operating at a wavelength of .6943 μm .

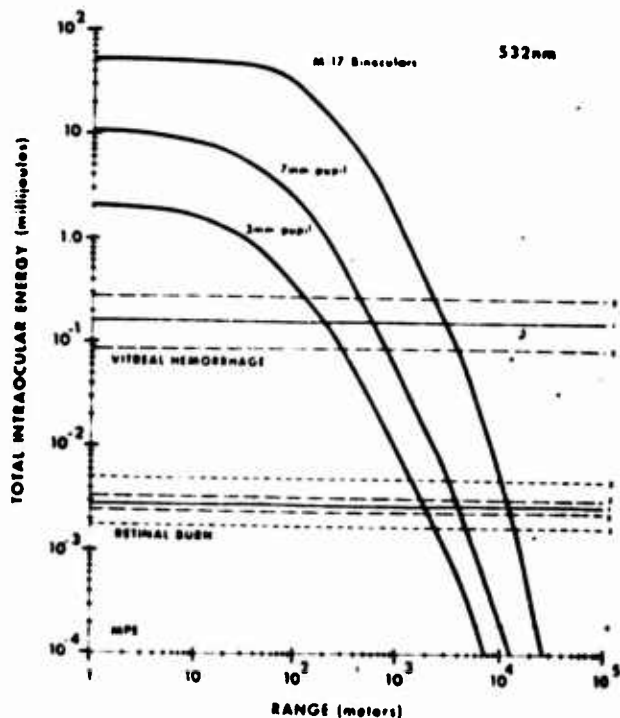

Figure 30* (lower left). Frequency double neodymium laser operating at a wavelength of .532 μm .

NOTE: The curves in Figures 28, 29, and 30 represent the calculated total intraocular energy as a function of range for three intrabeam viewing conditions: M-17 binoculars, 7mm pupil diameter (nighttime unaided viewing) and 3mm pupil diameter (daytime unaided viewing). Range calculations were based upon a laser which emits 100 mJ/pulse with a beam divergence of 0.25 mrad. Propagation through a "clear" non-turbulent atmosphere was assumed. The horizontal lines show the total intraocular energy required to produce the specified response in rhesus monkey eyes. Horizontal line 1 = ED_{50} ; 2 = 95% confidence interval about ED_{50} ; 3 = ED_{10} and ED_{94} ; 4 = the maximum permissible exposure (MPE).

*Struck, 1980, p. 64.

Field-Expedient Countermeasures For Magnifying Optics

Binoculars.

- o Minimize the search time of binoculars as much as possible.
- o Stow binoculars when they are not being used. When they are being held by hand, make sure the binoculars are held vertically and do not point towards the enemy (Figures 31 and 32).

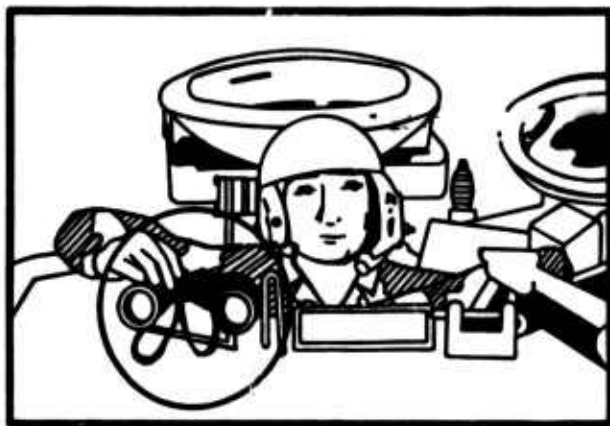

WRONG



RIGHT

Figure 31. Proper positioning of optics when in mounted position.

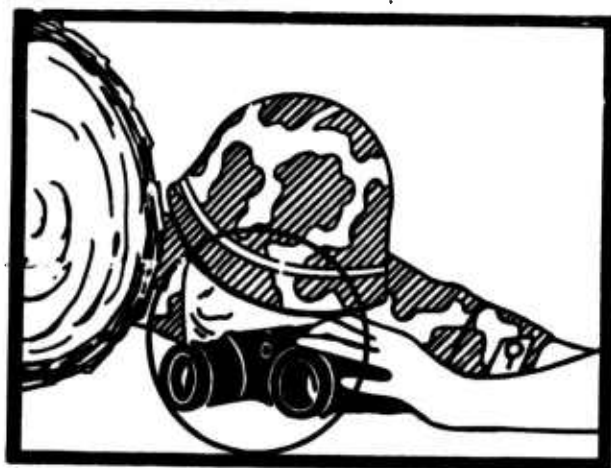

WRONG



RIGHT

Figure 32. Proper positioning of optics when in dismounted position.

- o Before using binoculars, scan the sector with the naked eye. If a laser is being used, the impact on the naked eye would be significantly less.
- o Adjust the binoculars to extreme out of focus before testing for the presence of a laser. When the binoculars are out of focus, they will concentrate less energy on the pupil, thereby lowering the risk of laser injury. If no laser is detected, then adjust for sharp focus.
- o Only use one eye to look through the binoculars.
- o Have subordinates do surveillance activities as much as possible.
- o Have only the minimum number of platoon members using binoculars at one time.
- o At no time have all the leaders looking at the same object at the same time while the leaders are in close proximity to each other when there is a potential of laser weapons. Instead, leaders should look at an area consecutively.
- o Put tape with a pin hole on one viewing lens for each set of binoculars in the platoon. Look through the taped lens first with the non-firing eye while keeping the firing eye closed. Then use the nonfiring eye to look through the untaped lens side of the binoculars. Using this procedure always protects the firing eye.

Daysight of the ISU

- o Use the AN/PVS-5 to look through the magnifying optic for surveillance and target acquisition. Image intensification devices will provide protection against laser eye damage (see image intensification section).

In a field test, armored-sized vehicles were easily observed at distances out to approximately 3000 meters on a sunny day using an AN/PVS-5 in conjunction with the narrow field of view (13 power) of an Improved TOW Vehicle (ITV). There is a need to maintain a certain spacing between the AN/PVS-5 and the sight lens for optimal performance. However, the spacing problem can be solved by the development of an AN/PVS-5 lens attachment which could maintain the correct spacing. In the absence of such a device, using one finger as a spacer between the sight and AN/PVS-5 will work. Figure 33 demonstrates how a soldier wearing an AN/PVS-5 and looking into the ISU can use his finger as a spacer to maintain optimal performance.

Additional research is needed to establish decision rules concerning when to use the thermal sights as a countermeasure to lasers and when to use the AN/PVS-5 and daysight combination. For example, the daysight and PVS-5 combination may be better for clear days, but as it becomes dark the thermal devices have more utility. The thermal devices can also be used during the day if the laser threat is great. In addition, there are questions regarding operator fatigue and performance. For example, how long can an operator use a

daysight and PVS-5 combination before there are complications such as headaches or eye strain? Or, can gunners make accurate adjustments to fire using these two devices in conjunction? If not, will specialized training improve gunner performance?

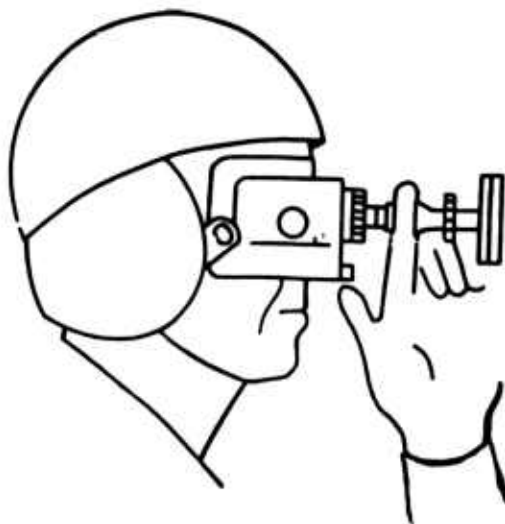

Figure 33. Soldier wearing AN/PVS-5 looking through the ISU using his finger as a spacer.

- o At all times keep all optics pointed away from suspected enemy positions and avenues of approach to avoid reflections, unless the optics are in use.
- o When the ISU cover is closed, be sure the backup sight is covered as well. This means covering the exterior glass with something such as tape or a sock.
- o When units are in concealed position, designate as few lookouts as is necessary for proper surveillance. All other units should remain concealed for as long as possible.
- o Have a squad member dismount and move away from the BFV and do initial surveillance. It will be more difficult to detect an individual doing surveillance than a vehicle. Only after the scout has observed a potential target opportunity should the BFV expose itself.
- o When the gunner fires the TOW he could close his eyes for short periods of time while the missile is in flight. This decreases his vulnerability to laser injury by reducing the exposure time of his opened eyes. Or the gunner could use the night-sight if a laser threat is present. Additional research is needed to identify the optimal intervals. Should the intervals be every other second, every two seconds, the first five seconds, the last five seconds, etc.?

Image Intensification (I²) Devices and Lasers

Image intensification devices are not direct-view optical systems; therefore, they could potentially provide some protection from both in-band and out-of-band lasers. Figure 34 shows the image intensifier tube blocking the direct path of the laser light.

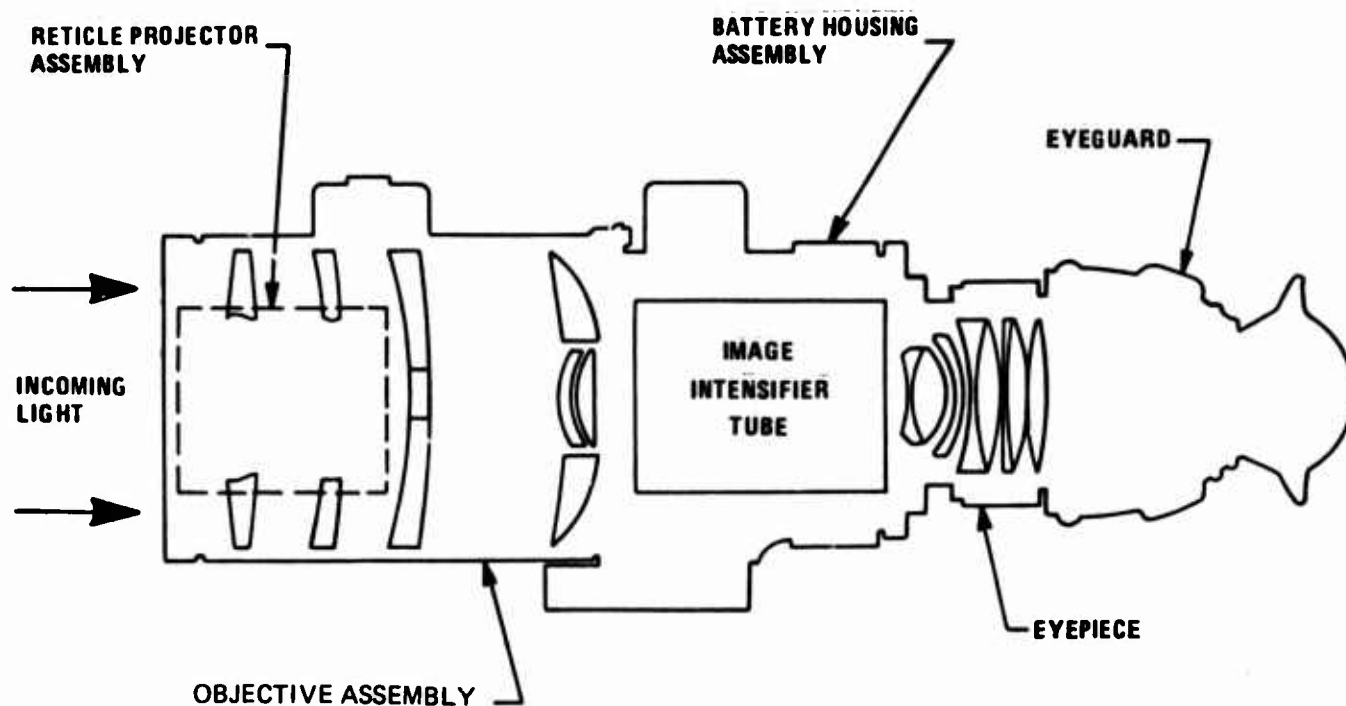

Figure 34. Optical schematic diagram of AN/PVS-4.

The image intensifier tube is a vacuum tube which amplifies light (Figure 35). This lets the human eye see things that are either too dim to be seen or are outside the range of normal vision (infrared light). There are three active areas in this type of intensifier tube: the photocathode, which converts light into electrons; and the MCP (microchannel plate), which multiplies the number of electrons within the tube in order to focus the image.

Because the photocathode blocks the path of the laser light, it protects the viewer. When in-band laser energy strikes an I² device, it appears the same as when a bright light strikes it. The laser light stimulates an excess of electrons in the image intensifier tube which causes the phosphor screen to flash a bright green and then the system will shut down and go black. The system will reset itself after a brief period. If the laser is powerful enough, it will deposit enough energy on the systems to cause permanent damage to some components.

Image intensifiers have a broader bandwidth (.35 - .9 μm) than visible light (.40 - .7 μm); therefore, it may be possible to detect some frequencies of laser

light that would be invisible to the naked eye. Consequently, laser targets on the battlefield could be located if they were transmitting on a frequency that was in-band to the image intensifier and out-of-band to direct view optics.

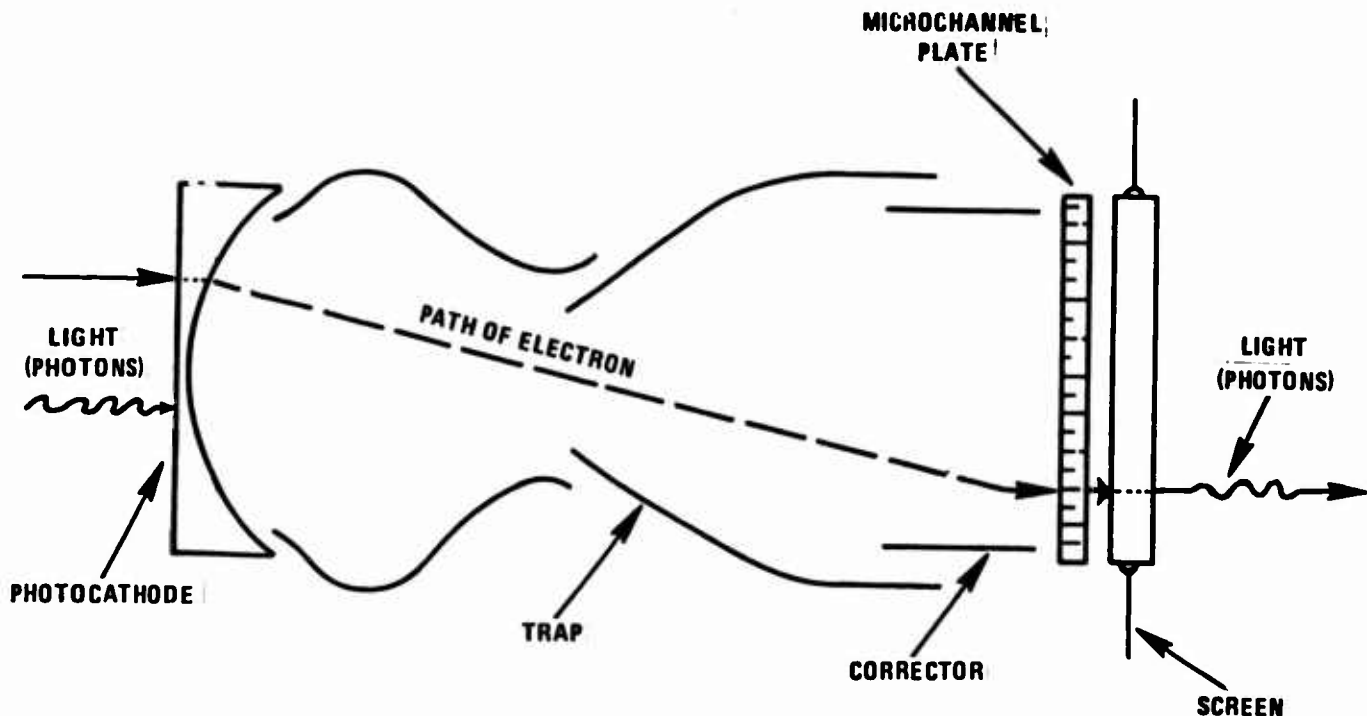

Figure 35. Schematic diagram of image intensifier tube.

Field-Expedient Countermeasures For Image Intensification Devices

One possibility for laser protection that may be helpful in some situations is to put a shroud around the lens to protect against off-axis laser attack. This does not protect the device from on-axis lasers, but it limits the effects from off-axis exposures. The tradeoff in this instance is the reduction in field of view.

A difference between the PVS-4 and PVS-5 is that the PVS-5 has two independent optical systems, one for each eye. Consequently, even if one side of the system goes down, the other could continue to operate. An additional possibility for the AN/PVS-5 is to put a piece of tape over one of the collecting lenses and use just one half of the system. If the uncovered half gets lased, it will show a bright green on the phosphorus screen then go dark. If it is permanently damaged, the user could untape the other half of the AN/PVS-5 and use it.

Image intensification devices can be used to determine the general location of a laser. If an I² device gets lased while a soldier is using it, the device will keep the soldier from being injured. If he notes the direction the I² was pointed when it was lased, he would have a general estimation of the direction

of the laser. This is due to the fact that lasers have to be within a few degrees of being on-axis to the I² device for a lasing to be noted. If two different units were lased by the same laser, there is the possibility of triangulating the two different directions to more accurately determine the location of the laser.

Although I² devices will help keep soldiers from being injured by the laser, there are tradeoffs. First, there is a serious reduction of the range at which the user can survey and acquire targets. Secondly, in a field trial using the AN/PVS-5 during daytime on a BFV in wooded terrain, it was discovered that a user with his head outside the turret was unable to see small tree branches. Consequently, these branches present a hazard because the user could be seriously injured if struck by a branch as the vehicle rapidly moves through a wooded area.

Thermal Devices and Lasers

Figure 36 is a block diagram of a thermal device. As can be seen, these devices are not direct view systems and they will provide laser protection to soldiers.

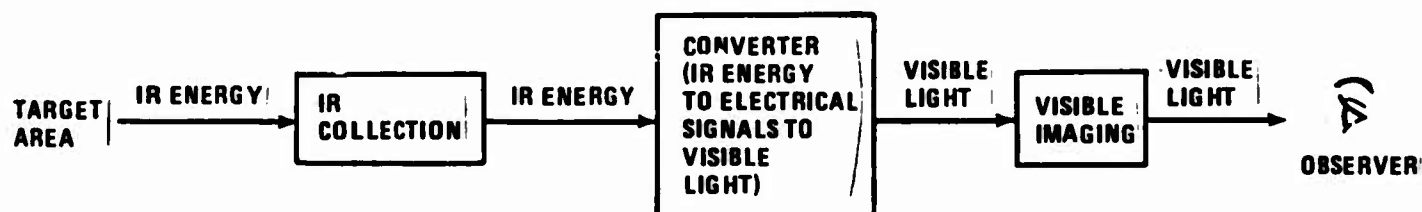

Figure 36. Block diagram of a thermal device.

The following figure presents a more detailed diagram of the operations of the ISU. Once again, it can be seen that when the ISU is being used in the night mode, it does not pass the incoming laser directly to the user's eyes. Thus, the ISU provides eye protection against laser attack when used in the night mode. Figure 37 presents a detailed diagram of the ISU.

Thermal device passbands are between 8 - 14 μm . Accordingly, they are out-of-band to visible lasers and visible light, but are in-band to far-infrared lasers. Consequently, if a frequency-doubled Nd:YAG laser (.532 μm) hits the night window of the ISU, it would either be absorbed or reflected off the germanium dioxide window. However, a CO₂ laser (10.6 μm) is in-band and its energy can pass through the window and burn out the detectors. The CO₂ laser presents a threat to thermal devices because it is in-band to thermal devices and CO₂ lasers propagate well through the atmosphere. Hence, thermal devices may be vulnerable to laser jamming out to significant ranges.

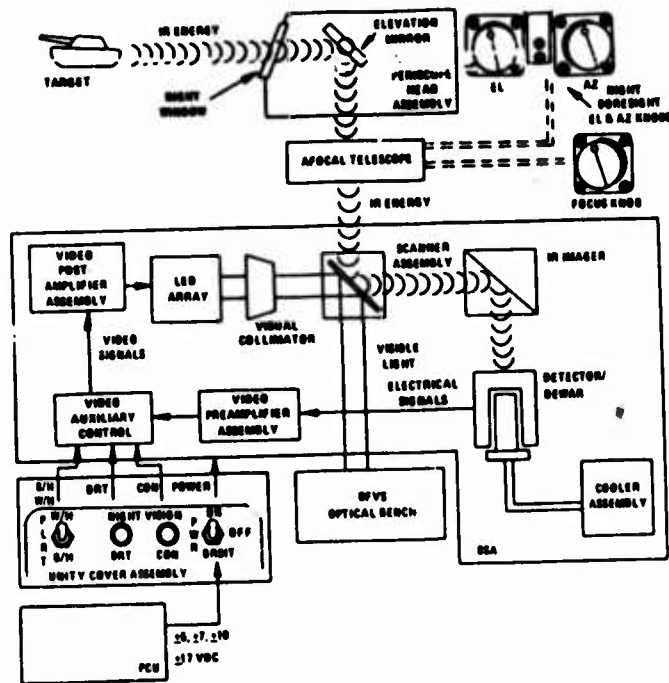

Figure 37. Detailed block diagram of ISU night sight.

Field-Expedient Countermeasures For Thermal Devices

Keep optics covered when not in use.

TOW IR Tracker and Lasers

The known effect of a laser on the IR tracker is presently limited-access information. If the IR tracker is vulnerable to laser attack, new tactics would have to be developed to reflect this reality.

Additional Countermeasures

There are several inherent weakness of laser weapons systems which are different from conventional systems. It would be fruitful to investigate the feasibility of exploiting these weaknesses as potential tactical countermeasures.

- o One weakness of low energy lasers is that there is no immediate feedback to the laser gunner of how successful his attack has been. He must continue to lase until he observes some evidence that he was effective, e.g., a vehicle coming to a stop or making a violet turn. Therefore, the longer a unit can maintain its operation in an apparently routine manner, the longer it would have to be lased to assure damage. Even if future laser doctrine, which recognizes there is no feedback for laser

attacks, calls for lasing of two seconds then moving to another target, continuing operation by the lased unit would still be beneficial because there would be a doubt about the effectiveness of the laser attack. Consequently, if injured personnel could continue their missions, this could relieve the likelihood of other vehicles being lased in the unit because the attacking laser would have to service each vehicle for a relatively long period of time. This may give other units time to effectively acquire and engage the attacking laser weapon.

- o Unlike conventional weapons, laser weapons will not cause injury unless someone looks at them; therefore, this would be helpful to defeat them. If a laser is in a position along with low priority targets, simply ignore the area if at all possible.
- o Stay out of potential laser line of sight, e.g., remain in the woodline, behind hills and ridges as much as possible. Strictly adhering to established rules for covered routes of movement will limit a unit's vulnerability.
- o Use indirect fire to defeat the laser weapon if it can be located.
- o Use intermittent observation. Instead of continually staring at an area, have soldiers look at the area for a few seconds every 10-15 seconds. Additional research is needed to establish the optimal procedures for intermittent observation.
- o A heavy smoke screen between a laser weapon and a potential victim could also defeat the laser, but it is necessary to use the right type of smoke. The effects of smoke are dependent upon the wavelength of the laser and the size of the smoke particles. As the size of the particle approaches the size of the wavelength, more of the energy will be scattered. Table 7 presents the interaction of wavelength with different types of smoke currently in the Army inventory. Notice that an out-of-band laser, e.g., CO₂ at 10.6 μ m requires an enormous amount of smoke to reduce the transmittance of laser energy to one percent of its incoming energy. Even with this amount of protection, some laser weapons are powerful enough to penetrate through the smoke and cause eye damage. Soldiers must be made aware of the limitations of smoke.
- o Laser weapons are highly susceptible to damage because they have sophisticated subsystems; thus, they are more sensitive and less rugged than other weapon systems. This implies that artillery may not have to have a hard kill to defeat them. There is the possibility that enough vibration from artillery explosions may cause an optical system to become misaligned and thus become useless. Also, if the laser system had to cross rough terrain at high speeds repeatedly, the associated vibration could damage the optical train; therefore, keeping it moving rapidly may cause a breakdown. This would increase the value of diversionary tactics to keep enemy lasers sprinting from place to place on a battlefield.

- o Another area of weakness of a laser weapon is the exit window or mirror for the laser. It probably is more susceptible to damage than armor because it must be made of a transparent window or a highly reflective material. Breaking the window with machinegun or other close range small-arms fire could render it useless, thus making the laser ineffective. Other possibilities to destroy the window/mirror include flechette or fragmentation artillery munitions for more distant or better emplaced laser transporters.

Table 7

Amount of Smoke in Meters Required to Reduce Laser Transmittance to One Percent of Incoming Energy

Agent	in meters			
	0.5 μ mm	1.06 μ mm	4 μ mm	10.6 μ mm
WP (White Phosphorous)	14	21	115	132
HC (Hexachloroethane)	10	16	105	659
Fog Oil	20	31	307	4610
FM (Titanium Tetrachloride)	9	21	77	121
Naphtalene	12	26	38	102
Anthracene	12	27	77	149
FS (Sulfur Trioxide - CSA)	4	8	171	220
Silicon Tetrachloride	8	15	118	384

Transmittance = 0.01

An additional susceptibility of the window/mirror is that it must be kept clean to be effective. If enough dirt was attached to the window, the dirt could create a non-transmitting hot spot which would absorb the energy instead of transmitting it outward. This would decrease the amount of energy going to the target. Also, there is the possibility that sufficient energy could be absorbed such that the window/mirror would crack or become distorted by heat. Artillery rounds landing near the vehicle could effectively deposit dirt on the window/mirror. To optimize this effect, artillery rounds with delayed fuses which bury themselves in the ground before detonation could maximize the dispersion of dirt and debris. Artillery presents an effective countermeasure by creating a dust cloud around the laser vehicle, and dirt contaminated mirrors or shattered mirrors would limit the effectiveness of the laser beam.

Finally, the development of an aerosol munition which could paint or corrode the window/mirror might be helpful in enhancing artillery's counter-laser role.

- o There is the possibility that lasers might be used in a battle but laser eye damage might remain undetected because the binocular action of the eyes would compensate for an injury to just one eye. Checks should be instituted when there is the suspicion of laser use in order to take appropriate action (e.g., make spot reports of the incident or institute countermeasures for the protection of other units). A platoon level check would have everyone test the vision of each eye periodically by closing one eye and observing whether there are any blind spots in their field of view. Such an injury would appear as a dark spot in the field of vision that would move as a person moved his eyes.

Another type of vision test could be used during night operations. At night, the eyes are dark-adapted. This means the eyes are using the rod cells of the eye as sensors and not the cone cells as in the daytime. If a laser damaged the fovea where most of the cones are located, this laser attack might go unnoticed because the soldier is using his rod cells for night vision. To check for lasing effects at night, each person could attempt to do a visual acuity task, e.g., read a map. If a foveal injury has occurred, a person would not be able to read the fine print on a map.

MICROWAVES

Another class of directed energy weapon is high powered microwaves (HPM). High powered microwaves operate in the 300 MHz (300 million cycles per second) to 300 GHz (300 billion cycles per second) range of the electromagnetic spectrum. For weapon applications, the general range of frequency is about 1 GHz to 100 GHz. (See Figure 38.)

Microwaves usually are discussed in terms of Hertz (cycles per second) and not in wavelengths, as lasers are. This may be somewhat confusing to the layman at first; however, it must be remembered that wavelength and frequency are two different measures of the same electromagnetic energy. Lasers could just as easily be expressed in frequency instead of wavelength and microwaves in wavelength instead of frequency. This report will follow convention and refer to microwaves by frequency.

Microwave energy is similar to light energy in that it can be absorbed, reflected, or transmitted through materials. However, materials which do this are different for microwaves than for lasers.

Although the microwave region of the electromagnetic spectrum ranges from 300 MHz to 300 GHz, the most militarily useful range is between 1-35 GHz. This is due to a combination of factors; specifically the atmospheric propagation properties of different MHz frequencies, the type of equipment needed to generate specific frequencies, the antenna size needed to broadcast different frequencies, and the energy coupling requirements of potential targets (Beavers & Bradley, 1984).

For an HPM weapon to be effective, it must have an enormous power supply and this has limited its military application previously. Recent advancements in power generation in both the US and the Soviet Union have now made such high-powered microwave weapons more feasible.

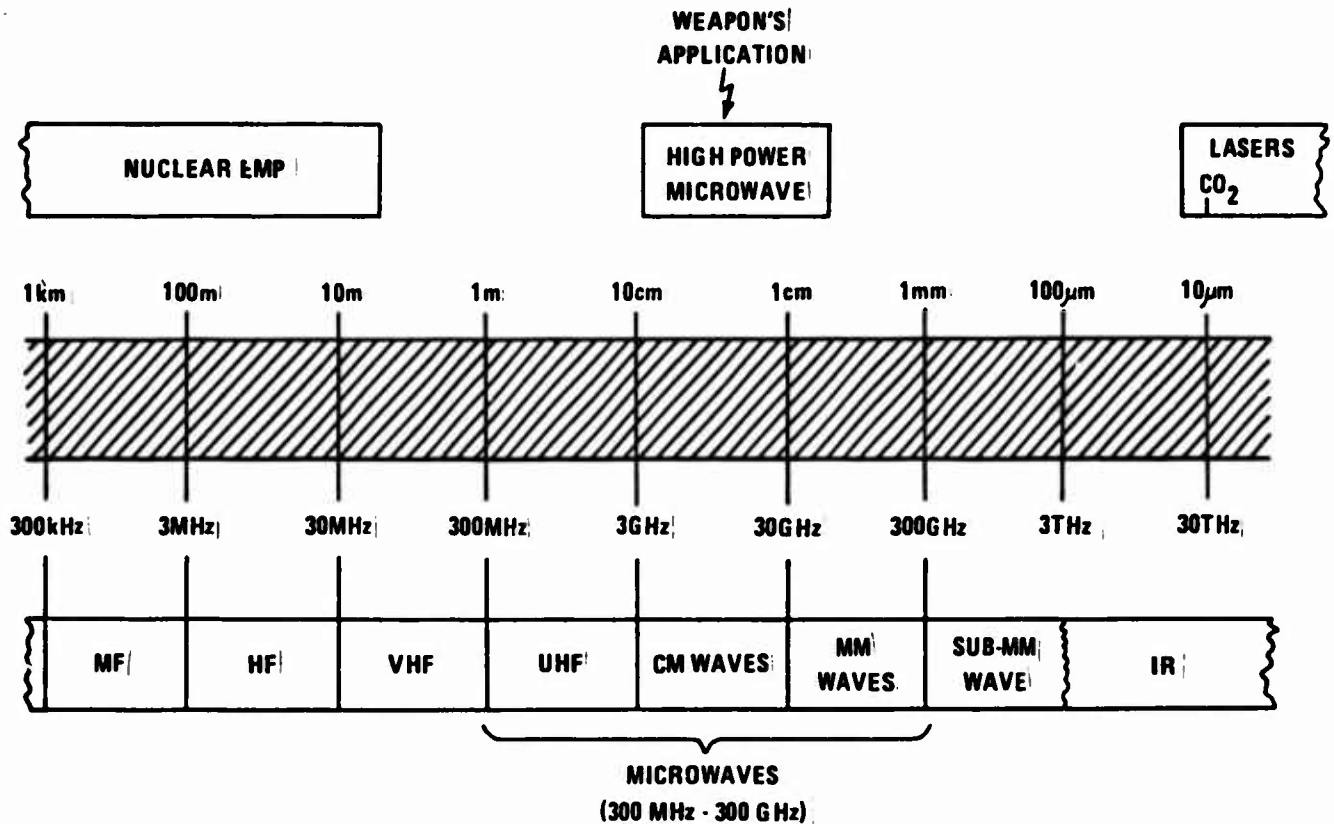

Figure 38. Microwaves and the electromagnetic spectrum.

For the foreseeable future, an HPM weapon will produce a soft kill by causing electronic upset and, at close ranges, electronic burnout. Electronic upset refers to a temporary jamming of the target, e.g., false signals from memory states of on-board computers which may interfere with normal operations. Electronic burnout occurs when a component is permanently damaged because it was thermally overloaded or an electrical insulator broke down due to a high energy surge.

The damage an HPM can cause is a function of the power of the weapon, range of the target, and susceptibility of the target. The closer the target is to the HPM weapon, the more energy can be concentrated on the target and thus the greater potential for damage. The following section describes the effects of

HPM on targets; however, it must be remembered that effects range from no impact to hard kill as the distance between the weapon and the target decreases.

Effects on Targets - Personnel

The thermal effects of microwave energy are widely recognized; however, there is much controversy as to the long-term, low-power (non-thermal) effects of microwaves on humans. Generally, 10 μ W (microwatts) is considered the boundary between thermal and non-thermal energy levels. The non-thermal effects are variously reported as headaches, fatigue, behavioral changes, nervous disorders, irritability, biochemical changes, memory loss, insomnia, dizziness, moodiness, confusion, cardiovascular effects, and immunological changes (Capstone, 1982; Beavers & Bradley, 1984).

The Soviet and other Eastern European nations started investigations on the subject of the biological effects of HPM in the early 1950's and have contributed most of the reports on effects of microwave radiation on humans. Eastern bloc countries have a great belief in the low power effects of microwaves to degrade performance and they have established higher operating safety standards than in the West except for military missions applications which are excluded from these standards.

The effects of microwave exposure on the central nervous system and behavior represent the most controversial subject in the field of biological effects of microwave radiation. A Letter Report from the US Army Foreign Science and Technology Center (10 March 1982) questions the validity of the non-thermal behavioral effects.

Postulated non-thermal effects, including heart seizure or behavioral changes, would be induced by low power density, but recent evidence indicates that these alleged effects were due to poor experimental procedure and do not actually occur. It now appears that the only feasible tactical RF [radio frequency] weapon would employ the process known as thermoacoustic expansion, in which pulsed millimeter wave radiation of modest power generates a pressure wave in biological tissue. This pressure would not be fatal, but should induce effects, such as damage to the cornea that would interfere with vision, or stimulation of carotid baroreceptors that would lower the blood pressure--with consequences inimical [harmful] to normal functioning of the targeted individual (p. 7).

The long-term, low-power effects are of little interest to the military; however, the thermal effects are relevant and must be noted. Three effects have been positively identified as potential biological hazards to personnel: microwave hearing, ocular lens clouding, and corneal endothelium damage.

A pulsed HPM will produce thermoacoustic or thermoclastic expansion. This is the process whereby the microwave energy is absorbed by the cells of the

body causing a rapid increase in heat and expansion in those cells. This, in turn, causes a pressure wave that can be quite damaging to the tissues. One example of this at a low power is "microwave hearing." Microwave energy deposited on the brain stimulates the cochlea (a part of a bone in the ear) which causes a sound to be perceived. Such a phenomenon may disrupt military performance because it could interfere with a soldier's hearing.

The most potential important aspect HPM has on humans in a military setting is the effect on eyes. There appears to be two major potential hazards to the eye: damage to the corneal endothelium and the lens (see Figure 39). The corneal endothelium is the last layer of the cornea that separates it from the aqueous. If this layer is disrupted from a pressure wave caused by a HPM, the fluid of the aqueous will come into contact with the cornea. This will greatly reduce the victim's ability to see and will cause intense pain due to the numerous nerve endings in the cornea. "The resulting reduction in vision would occur immediately and be temporary or permanent depending upon the degree of damage to the endothelium (Beavers & Bradley, 1984, p. 30)." The second major injury would be the clouding of the lens, or cataracts, caused by HPM.

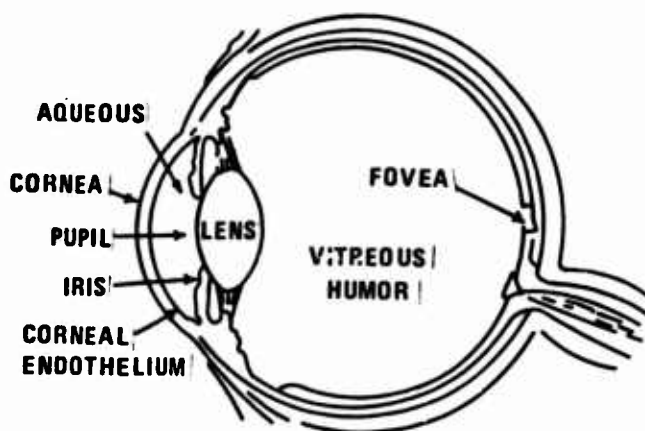

Figure 39. Cross-section of the human eye.

Tables 8 and 9 present power densities for sensation of warmth and pain thresholds.

Table 8

Power Density and Exposure Time to Produce Sensation of Warmth

Exposure Time (sec)	Power Density At 3 GHz (mW/cm ²)	Power Density At 10 HGz (mW/cm ²)
1	58.6	21.0
2	46.0	16.7
4	33.5	17.6

Note. The surface area irradiated to provide the above data was the forehead (approximately 37 cm²) (Capstone, 1982, p. 4-9).

Table 9

Threshold for Pain at 3 GHz

Power Density (W/cm ²)	3.1	2.5	1.8	1.0	0.8
Exposure Time (sec)	20	30	60	120	180

Note. (Capstone, 1982, p. 4-9).

HPM Effects on Equipment

The mechanisms on how HPM impacts on weapon systems are not well understood. The phenomenon of electrical upset and burnout has been observed for weapon systems. However, there is a wide range of effects even for the same systems. For example, the impact HPM has on the same type missile may vary greatly from trial to trial. Sometimes different components break down in each trial, and at other times the same subcomponent could receive a magnitude more energy than a previous trial and remain functional. These findings are very system-specific, requiring each system to be fully tested individually. In addition, the problem is further complicated by the fact that when a component is integrated within the full system, the susceptibility to HPM damage of the component and the full system may change. Consequently, entire systems must be assessed and not just components.

Generally, as weapons become more electronically sophisticated (i.e. medium and large scale integrated circuits), the more susceptible they become to HPM.

Potential HPM targets include:

- o Acquisition and tracking radars
- o Command, control, communications and intelligence (C³I) facilities

- o Electro-explosive devices (EEDs)
- o Missile guidance
 - a. antiaircraft
 - b. antitank
 - c. antiradiation
- o Fire control computers
- o Electronic warfare equipment
- o Avionic systems
 - a. airplanes
 - b. helicopters
 - c. remotely-piloted vehicles (RPVs)
- o Satellites
- o Night vision devices

Some potential HPM applications are:

- o Combined acquisition and electronic kill radar for air defense (fixed and mobile sites);
- o Protection for major command and control posts against antiradiation missiles (ARMs);
- o Attack concealed personnel;
- o Incapacitation of ordnance fuses;
- o Burnout of optical elements and sensors;
- o Large area battlefield sweep antielectronics weapon to neutralize communications and control systems;
- o Mobile "mine fields"--microwave antipersonnel barriers;
- o Promising future advanced technology missions, such as radome blow-off of missiles.

What is known about the specific effects of HPM on military targets is in preliminary form; however, the effects could prove to be significant. There are some inherent problems with the HPM which may make it unlikely as a

tactical weapon. It is more likely to be deployed as a division defense weapon. HPM tactical employment shortcomings include:

1. A large visual signature due to the size of the antenna (2 meters and up).
2. A large vehicle mount is required in combination with a second vehicle which would provide the power generation as well as all associated operational subsystems.
3. A very distinctive electronic signature is emitted which will be readily detectable from great distances.
4. Relatively large side and back radiation lobes make proximity areas hazardous and the general area will have to be kept clear of friendly troops.
5. Potential down range fratricide problems are possible because of beam spread.

Countermeasures

Although there are gaps in the data base regarding how HMP affect total systems, there is a large body of knowledge from nuclear EMP and radar data that suggests countermeasures could be developed by rigidly adhering to military specification standards and shielding bare wire.

For individual protection, Faraday suits (a suit with wire mesh incorporated in the fabric) will cause the microwave energy to be reflected. Also, placing a wire mesh material in front of vision blocks or anything else will keep the microwave energy from entering through them.'

CONCLUSIONS AND RECOMMENDATIONS

This review and analysis identified six major problem areas regarding the status of DEWs and the infantry.

There is General Ignorance of DEWs Army-wide

The most significant finding is that there is a general ignorance of directed energy weapons Army-wide. The major exceptions to this are the materiel development and intelligence communities involved in DEWs-related issues. Much of this ignorance is due to the highly sensitive nature of DEWs technology. Previously, it made sense to keep much of this information classified to protect intelligence sources and not divulge US plans. However, since the Soviets appear to be fielding some type of DEWs, it is now time to disseminate DEWs information to the troops to prepare the Army for DEWs combat. Unfortunately, this has not been done. There is virtually no awareness among US soldiers or officers not directly involved in DEWs research concerning the

potential impact of DEWs. Consequently, the Soviets know they will be fielding DEWs, the US intelligence community knows the Soviets will be fielding DEWs, and the only people who are not aware of this are the soldiers in the US Army.

A comprehensive plan to educate the Army is needed to overcome this deficit. A model to follow would be: (a) get general officer support and command emphasis on this matter, (b) educate mid-level managers who would be able to budget sufficient resources in the coming years to address the emerging directed energy issues, (c) begin to develop potential tactics and training programs, (d) train the trainers, and (e) train soldiers.

General officer support appears to be present at least at the higher levels. What is needed at this time is to allocate the necessary resources to seriously address DEWs issues in the user community. This means the O-4 to O-6 level managers units must be educated because they are the ones who can budget the resources in the coming years to address these issues. Once these personnel become aware of DEWs, they should be motivated to allocate sufficient funds and personnel to address the DEWs training issues at the action officer level.

Additionally, creating a civilian position dedicated to DEWs issues would be very helpful at the Directorate of Training and Doctrine (DOTD), US Army Infantry School (USAIS) in order to preserve institutional memory. During the course of this study (a period of approximately 8 months) the author interacted with four action officers, two branch chiefs, and three division chiefs at DOTD, USAIS. Such a high personnel turnover rate impedes long-term planning and follow-through.

Also, the organizational structure of the US Army Infantry School does not allow for the most efficient approach to the DEWs problem. This is because DEWs are new and cross the functional boundaries of the established directorates. A more efficient method would be to develop a task force at the Infantry School to look at the entire DEWs problem (hardware, tactics, and training) in an organized, systematic fashion.

There is a Need for DE Institutional and Unit Training

There are only a few unclassified publications on the subject of DEWs, consequently, there is a critical scarcity of information available to the soldier. A recommended first step is to develop of a "TRADOC Bulletin" type of booklet on DEWs. Further, it should be mandated that all new institutional publications, e.g., Field Manuals (FMs), Training Circulars (TCs), etc., reflect DEWs information and considerations where appropriate in a simple, combat-relevant manner. Appendix A of this report offers a suggested outline for a DE POI.

Suggestions That Will Aid Future Training.

- o Develop a standardized vocabulary for reporting effects using as few new terms as possible. For example, fluence was described in units of mJ/cm^2 , J/cm^2 , and KJ/cm^2 and wavelengths were reported by some agencies in micrometers and by others in nanometers, e.g., a ruby laser was $.682 \mu\text{m}$ vs. $682 \mu\text{m}$. In addition, various publications present the electromagnetic spectrum in descending wavelength order and other publications present it in ascending wavelength order. Such differences in reporting are confusing for the nonprofessional. Limiting the new terms to a minimum would speed comprehension and limit errors by the troops.

- o There are several factors involved in determining the potential lethality of a laser: the size of the exit aperture, the output power, pulse length, repetition rate, beam spread and wavelength. It is difficult for nonengineers to understand the relative contribution of each factor. What is tactically significant is how far it will shoot and what damage is possible. Currently, there is no unit of measure that establishes the power of the weapon in a combat relevant manner. For example, a commander would have a different mind set regarding the presence of opposing 82mm mortars vs. 120mm mortar effectiveness against his units. Knowing this information allows the commander to adjust his tactics accordingly, and it also may give him an estimation of relative enemy troop strength because, for example, 82mm mortars would be fielded with a mortarized rifle company and the 120mm mortars would more likely be a regimental asset. Also, he would be able to communicate this difference to others in a concise and meaningful way.

Unfortunately, there is no similar way to compare the differences in lasers. What would be the difference between a 100 watt ruby laser with a pulsed frequency of four per second, a 300 μsec pulse length, and a beam spread of 25 μmrad compared to a 60 watt neodymium:YAG laser with an eight pulse repetition rate, a 200 μsec pulse length, and a beam spread of 50 μmrad ?

The same would be true of radio frequency (RF) beam weapons. Their measures are reported in: frequency (GHz), output power (GW), pulse rate (Hz), pulse length (μs), antenna diameter (m), antenna gain (dB), power density (W/cm^2) at distance X, and tracking accuracy (μmrad).

All of this information is meaningless to the average soldier. Therefore, it is recommended that a standard laser unit or HPM unit be developed. For example, such a standard laser unit could be developed using a ruby laser as the standard. All other laser systems would be measured against this standard and would be expressed as a function of the standard laser. For example, 2 standard laser units (slu) would indicate the laser is twice as powerful as the standard laser, .3 slu suggests that the laser is one-third as powerful. To make a "slu" meaningful, a combat reference chart could be developed that demonstrates the probable damage in combat-relevant terms. For example, at X distance soldiers looking through the TOW optics would be flashblinded; at Y distance the thermal device would show evidence of permanent damage; and at Z distance image intensifiers would shut off. In this way, soldiers would only

have to learn one combat reference chart for in-band lasers and one for out-of-band lasers, and then they could have an immediate estimation of the capabilities of any other laser system. This would be especially helpful as more and more lasers of different types are fielded in the future. With slw measurements, one for in-band lasers and one for out-of-band lasers, comparisons can be easily made between different types of lasers. Thus the relative effects of different lasers or RF weapons could be easily understood by Army personnel, and this would alleviate some training problems.

- o A classified introduction to DEWs training film. At this time the best summary of DEWs is found in the 300 page Capstone Manual. This is an excellent publication, but unfortunately it is too long and too technical to be of use to the average military officer who simply does not have enough time to read it. During the course of this study, the author found that virtually no officers have read it unless required. A training film would help to alleviate this problem. This DEWs film should be a "NOVA" type presentation of what lasers and HPM are and what they are not. This film also should begin to present a realistic appraisal of the potential for materiel countermeasures.
- o An unclassified training film on lasers and HPM for soldiers. This film should address the general characteristics of lasers and HPM phenomena. This film could be used to begin the process of desensitizing soldiers to the reality of lasers.
- o A TRADOC-sponsored traveling demonstration team would be helpful to disseminate accurate information. There are four advantages of a live demonstration team: (a) live demonstrations are more potent than just viewing films or reading literature; (b) as this is a rapidly evolving field, new information can be continually incorporated into the team's presentations; (c) the team can tailor presentations to the level of the audience (secret vs. confidential, officer vs. enlisted); and (d) a demonstration team could answer unique or unexpected questions which are not addressed in publications.
- o Develop dust generation techniques for the M2/M3 and other Army vehicles. Drivers could be trained in ways to create as much dust as possible using their vehicles, or by dragging branches behind them. Such dust procedures may prove to be an effective countermeasure against lasers in suitable environments. If it does prove to be effective, then such exercises should be made a part of all driver training.
- o Develop training aids that will assist in DEWs training. For example, develop a radio-controlled flashlamp that can be mounted at various positions on the Bradley and can be controlled by a trainer. The trainer can remotely flash individuals or combinations of individuals in the Bradley during training exercises. In this manner, the crews will be forced to develop and practice evacuation procedures. This also will begin to reduce the fear of being blinded in combat.

- o Have those involved in developing DEWs tactics and training attend the developmental testing of new DE equipment. As there has been no field experience with such weapons, even experimental hardware testing should provide an excellent opportunity to gain insights into the nature and scope of DEWs warfare.
- o There is virtually no military experience regarding the impact of tactical directed energy weapons on current Army weapon systems. Additional research is needed to investigate the ramifications of DEWs on the battlefield at the platoon and squad level. Some tentative passive defensive countermeasures have been identified. Additional research is needed to validate the feasibility of implementing identified countermeasures as well as developing new countermeasures. These would include the use of dust generation procedures, the use of the AN/PVS-5 in combination with direct-view optics, and the use of tape on vision devices. The goal of this research is to permit military units to operate effectively in a DE environment by identifying the best courses of action during a DEWs engagement. An example of such an effort is found in Appendix B, Crew performance of a M2 Bradley under simulated laser attack: a pilot study.

Psychological Implications of DEWs for Soldier Behavior. There is an urgent need for a unit DE training program not only to prepare soldiers to fight in a DE environment, but also to help soldiers prepare psychologically.

One of the greatest gaps in the data base of directed energy is how soldiers would react once they are lased. This question is of paramount military significance. Obviously, there is no military experience with lasers except for some alleged Iranian-Iraqi and Soviet-Chinese incidents. In addition, there are no human experimental studies that address this issue because of the risk to soldiers involved with DEWs research.

Two central issues of military concern are whether an individual soldier will risk his vision by looking through a sight which had just passed laser radiation and caused injury to a fellow soldier, and whether there will be a general panic by soldiers forced to fight against lasers.

A data source which may shed some light on these topics is the post hoc analysis of victims' reactions to laser accidents. One of the best attempts to address this issue was Wolfe (1983) in his review of laser accidents. He found there was a wide range of reactions among those who received laser injuries. A scientist, well-familiar with lasers, fainted when he was badly injured, other persons receiving laser injuries continued to work. It has even been suggested that there have been workers who have been severely injured but have never reported it because of fear of reprisal from their employers since a laser accident usually indicates that some safety guideline has been violated. Wolfe's data suggest that there have been a wide variety of reactions to laser injuries. An individual's reaction to a laser injury appears to depend upon the severity of the injury and the inherent difference between the individuals involved.

It is the author's belief that much of this variance in reaction to laser injuries could be reduced by a proper laser training program. A major difference between the previous laser accident victims and future laser military casualties on the battlefield is that the victims to date have had no previous training or expectation of how to react in the event of such an incident. Consequently, in the absence of training, a victim's behavior in reaction to a laser injury would be a function of the severity of the injury, the individual's personality and his own unique learning history. Thus, a wide variety of differences could be expected in how people might react when they are injured by lasers. This is observed in Wolfe's data.

However, a common set of experiences, specifically a laser training program designed to address this issue, could reduce the variance of behaviors among laser casualties. Generally, in a crisis a person will react the way he was trained by repeated practice. Obviously, there are exceptions to this, but most of these exceptions are a result of a person being overwhelmed by anxiety. A good training program includes reaction drills which help a person prepare for emergency situations and reduces anxiety.

There would be four benefits from an Army-wide DEWs training program.

1. Desensitize soldiers to the reality of lasers. Initiating a laser training program or raising DEWs issues in a classroom instruction would begin the process of desensitizing soldiers to DE. This would go a long way toward psychologically preparing soldiers to face these weapons.

2. A common set of experiences. Soldiers going through a laser training program would have the same set of experiences. This commonality in itself should reduce the variance of their behaviors if wounded by laser weapons because they would have a common learning history and drilled reactions.

3. Train constructive behaviors. The variance of soldiers' behavior could be reduced further by teaching soldiers productive actions to be taken immediately upon recognized injury. This action would help them to remain calm.

4. Provide accurate information. Accurate information is important to dispell myths about lasers and to give soldiers a realistic appreciation for what lasers can and cannot do. At this time, common rumors and myths about lasers include the idea that lasers cause sterility or lasers are less powerful in the daytime. If such myths are existent today, one can only imagine what the rumors will be when dedicated laser weapons are fielded in the future.

There are three facts that should be communicated to soldiers which should counteract some of the potential fears they may have of lasers. These facts provide hope of survivability and recoverability. First, lasers can cause anything from a quick flashblinding to permanent eye damage. This fact about lasers is surprising to many because it is often assumed that once blinded, the damage is permanent and there is no hope of recover. This is simply not always true.

Another fact is that once a person is injured, he cannot know the extent of his injury until examined by medical personnel. This is important information for the soldier to know because it gives him the hope that he can recover from a laser injury he may have just sustained. This should lessen his tendency to panic in a crisis situation. It would also aid his fellow soldiers in fulfilling their unit's mission in that they would be more willing to risk their own safety by taking the injured soldiers' place.

Furthermore, according to some experts, the chances of bifocal injury (both eyes being injured at the same time) are relatively small because at distances there are hot spots in a laser beam. A laser beam may have a diameter of a meter at 1 km, but the fluence level of the beam is not uniform at all points across the beam. There will be hot spots and cold spots in the beam and the fluence levels of these hot spots could change and migrate due to atmospheric conditions. Additionally, for complete blinding to occur, the optic nerve area or the foveal area of the retina must be damaged. This would require an on-axis line of sight between these specific areas of the eye and the laser. Thus, there is the real possibility that the laser beam would damage a non-critical area of the eye. The exact probability of non-critical eye injury vs. a critical eye injury has yet to be determined, but the incidence of possibility of critical eye injuries may be relatively low.

Finally, soldiers have been trained to face machineguns, tanks, chemical, and nuclear weapons and there is no reason to believe that, given proper preparation, soldiers will not fight in a DE environment. Certainly, a DE environment will prove some challenges to the infantry and a DEWs training program is not a panacea for the directed energy problem. There will be soldiers who will panic and take counter-productive actions when injured, but this has always been true in combat. Realistically, the Army has little choice but to develop a DE training program; otherwise, it will have to be accepted that the individual soldier reactions will be left to chance.

Consequently, the real question is not whether to develop a DEWs training program but which type of program would be best. Such a program should have the following goals:

- o Desensitize soldiers to DEWs,
- o Teach facts regarding DEWs,
- o Develop productive counteractions to DEWs attacks.

DEWs information, with the above facts and goals in mind, must become a part of all relevant publications, classroom instruction, and unit training.

Potential Political Consequences of DE Training. Before embarking upon an extensive campaign to educate the Army regarding directed energy issues, the political and social consequences of fielding such new weapons must be given serious consideration. Articles on directed energy weapons have appeared in the popular press in the past but were more typically published in technically-oriented magazines, e.g., Aviation Week. Also, most of these articles centered

on the high technology issues of destroying strategic missiles. This area received additional impetus after President Reagan's "Star Wars" speech in May of 1983 that endorsed a high-tech approach for strategic nuclear defense. The public reaction to high-tech weapons appears to have focused on issues of the potential effectiveness and cost of these weapons and the potential upsetting of the world balance of power.

The general public's criticisms of tactical DEWs weapons may be different from strategic DEWs applications because they would center on the ethics of the employment of such weapons. Tactical weapons are more person-oriented than equipment-oriented like strategic weapons. An article in the Washington Post (17 December 1983) (see Appendix C) highlights this issue. Although many of the details of the article are erroneous, the thrust of the article focuses on the blinding and maiming capabilities of the weapons. Also, an article in Army Times suggests that the cancellation of an Army laser program, close combat laser assault weapon (CCLAW), was done for humane reasons. This was later disputed by the Chief of Staff of the Army. It is reasonable to expect that more articles raising the issue of the ethics of DEWs will appear in the press as the Army prepares for a DEWs battlefield. Such articles may not be authoritative or technical sources of information, but they do influence the reactions of the general public. Some policy decisions will have to be made regarding how to handle such criticism. Five possible avenues are offered.

1. Ignore the popular press.
2. Emphasize the defensive nature of DEWs weapons which reduce effectiveness of threat offensive weapons by jamming them.
3. "Leak" information regarding Soviet capabilities that require US forces to develop similar technology.
4. Assert that DEWs weapons are not functionally different from currently fielded systems, e.g., laser rangefinders, radars, laser designators.
5. Carefully explain the capabilities of each weapon system.

Army public relation officers must be informed about directed energy and must be prepared to address these issues. A position paper must be prepared at DA level explaining the official Army position in response to the inevitable inquiries from the media.

Current Security Classifications Present Training Obstacles

One of the major obstacles to educating the Army and producing effective training programs is the security classification of specific DEWs information. Soviet Military Power (DOD, 1983) was the first official unclassified publication which suggested the date on which the Soviets were expected to field a DEWs (mid-80's). This was certainly a step in the right direction; however, the fact that the Soviets are fielding weapons is not enough information for the Army to prepare its soldiers for the next conflict. Clear guidelines must

be established at DA level as to how much specific information can be given to US troops. It is recommended that the Infantry School initiate efforts to reclassify such information for needed dissemination.

Specifically in need of reclassification are some anticipated initial operational capabilities (IOCs) of selected threat systems and some of the unique capabilities of lasers. This information should be made known to soldiers on a need to know basis. Currently, soldiers do not understand the hazard ranges involved with lasers. Also, there is no soldier awareness of which types of optics require protection, how they should be protected, or under what circumstances they should be protected. Specific areas of interest are vision ports, magnifying optics, headlights or taillights, windshields, or a soldier's eyeglasses. It is presently difficult to fully prepare soldiers regarding these issues without divulging classified material.

Further, making demands on troops to maintain optical discipline without giving an adequate explanation of the purposes (i.e. laser protection) may not be effective because these demands could be perceived as an unnecessary burden which may degrade general performance. Consequently, there might be the temptation to take shortcuts in training exercises. Thus the only way soldiers would be likely to exercise optical discipline in a training environment would be if their NCOs and platoon leaders forced them to do so. Also, platoon leaders may be reluctant to force troops to do something which serves no apparent need unless the company commander places emphasis on the issue. This reluctance may apply all the way up the chain of command.

In addition, if soldiers fail to train in an optically disciplined environment, they will lack the experience of developing interunit reliance for surveillance. For example, they would fail to value the use of a designated scout and fail to develop standard operational procedures (SOPs) for DEWs engagements.

Therefore, it is suggested that Bradley personnel be given classified clearances to allow them to have access to certain information on a need-to-know basis. One of the benefits would be to increase the relevance of training. A cornerstone of an effective training program is to make the requirements obvious to the soldiers. By understanding the purpose of maintaining optical discipline, soldiers would have a greater appreciation for it. Even though optical discipline may be viewed as a cumbersome procedure, it would be more likely to be accepted because of its relevance to their safety. An excellent parallel would be soldiers' acceptance of NBC training. Nothing is a greater hindrance to performance or causes more discomfort than mission oriented protection posture (MOPP) gear, but soldiers accept the necessity for such training because they understand the need for it.

Secondly, it is more effective to teach the principles of laser capability to develop a "mind set" than it is to teach a number of specific, seemingly meaningless behaviors which would have to be done in lieu of reclassification. No matter how exhaustive a list of behaviors could be, there would be situations which can be overlooked. Teaching soldiers some of the classified

information would develop a proper mind set and alleviate this training problem by establishing purpose and therefore providing motivation.

Current Army doctrine calls for the development of initiative and creativity on the part of the soldier. Indeed, it has been one of the hallmarks of the American soldier to demonstrate such resourcefulness. Depriving the soldier of some DEWs information would make it extremely difficult for this potential resource pool to be developed. History clearly illustrates that this resource should not be underestimated. Even though there are many excellent scientists addressing the problem of DE, there is still room for the individual soldier to make contributions in the development of materiel, tactics, and training programs. It is unlikely that this could occur if the principles of DEWs were kept from him.

The alternative to reclassification is to overemphasize the importance of maintaining optical discipline, e.g., by declaring automatic failure of an Army Training and Evaluation Program (ARTEP) if any optics are observed to be uncovered when not in use.

Another possible alternative is to state plainly, "The reason for keeping covered optics which are not being used, even many kilometers from the forward edge of the battle area (FEBA), is classified." This has the advantage of giving soldiers an appreciation for the distances involved. However, if not given a clear reason, soldiers will be forced to speculate about the real purpose. This is fertile ground to spawn rumors and myths which may be difficult to counteract as well as distort concepts regarding DEWs which are available in the open press. The best way to guard against this is to present the facts initially.

There is a Lack of DE Related Doctrine

There is the need to develop the principles of directed energy warfare. Current efforts can best be described as efforts to establish doctrine without having synthesize the insights gained from computer studies, field trials, etc., into a larger theoretical framework. Indeed, it may be premature to even hope for such a comprehensive, integrative theory, but nevertheless this is a goal which must be kept in mind.

Figure 40 is a graphic representation of how the principles of directed energy warfare could help to integrate the findings from different directed energy studies.

If a collection of principles was ever developed it could provide much needed insights into the nature and scope of DEWs warfare. For example, what differences exist between DEWs weapons in the offense vs. defense? There must be some differences. Another question is, what are the differences between a high intensity conflict vs. a low intensity conflict? How will things change under those circumstances? It may be reasonable to posit that in a high intensity conflict, a laser weapon may be just an evolutionary trend in weapons development because it would represent just a small percentage of total combat

power. However, lasers may be a revolutionary development in low intensity conflicts because very simple devices could clearly cause tremendous problems. This is because in low intensity conflicts a response to a laser attack must be limited. One cannot call in massive artillery support, especially if the weapon is located in a high density civilian population area. The DEWs technology provides opportunities for advantages to otherwise unsophisticated users.

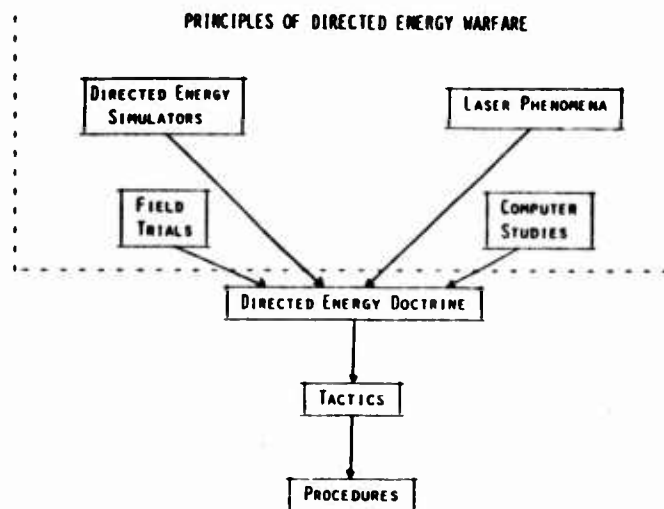

Figure 40. Principles of DEWs warfare.

Certainly, at this time such differences cannot be fully enumerated but intuitively there must be some differences. Concept formation along these lines would greatly aid the Army in understanding the nature and scope of DEWs warfare. It would be very easy to overlook the need for such theoretical development and therefore lose the opportunity to fully prepare for the reality of directed energy use.

This theoretical concept formation also needs to be extended to the countermeasure devices. A good example is the concept of eye armor, soldier's safety glasses. Should eye armor be conceptualized as a boot to be used during all combat and training exercises? If anyone appears without eye armor it would be considered the same as not being in uniform? Will eye armor be like a helmet to be worn during all training and combat but not necessarily in garrison? Will it be treated like a flak jacket to be worn only by high risk units in combat and in special training situations? Or will it be like MOPP gear to be worn only during special training exercises and in combat after there has been a spot report of a NBC being used.

These questions must be addressed and policies established. Sound theoretical formulation is needed to provide guidelines before such decisions can be intelligently made.

An example of this which demonstrates the benefits of such theorizing is Gray's Countermeasure Grid (J. Gray, personal communication, May, 1984). In a small way, this conceptual model organizes the DEWs countermeasure data and issues in such a manner that insights can easily occur (see Figure 41).

Gray's model organizes countermeasures into four categories across active/passive and materiel/tactical dimensions. First, countermeasures can be categorized whether they are materiel or tactical. Secondly whether the countermeasure is active, i.e. something which has to be done in response to an attack or in anticipation of an attack; or whether it is passive, i.e. something which is already in place or SOP to a unit. When countermeasures are conceptualized in this manner it is readily apparent that materiel solutions to the DEWs problem are only half the story.

	MATERIEL	TACTICAL
ACTIVE	Detectors	Intelligence
	Shutters	Surveillance
	Smoke	Counterfire
		Maneuver
		Procedures
		Drills
PASSIVE	Filters	Cover
	Shrouds	Concealment
	Covers	Camouflage
	Goggles	

Figure 41. Gray's countermeasure grid.

The utility of this model becomes apparent when it is applied to current US Army directed energy countermeasure efforts. It is clear that the materiel solutions (the upper left and lower left quadrants) are certainly being

addressed by the materiel development community. Also the tactical passive (lower right quadrant) dimension has already been ingrained into military preparation because such measures have always represented sound combat doctrine. However, some of the elements of the active/tactical category (upper right quadrant) have not been given sufficient attention; specifically, maneuver, procedures, and drills. Further attention must be given to these areas if the Army is to develop a comprehensive DEWs countermeasure program.

In the above example, Gray's model provides a useful tool to analyze the Army's countermeasure efforts because it organizes the principles of countermeasures in a systemic fashion. Thus the diverse elements of separate countermeasure categories, e.g. shutters and drills, can be meaningfully related to each other within the broader framework of a comprehensive countermeasure package. Similarly, the principles of directed energy warfare need to be elucidated so the elements from diverse sources can be meaningfully related to each other to formulate the most effective DEWs doctrine.

Another issue is that there is no doctrine regarding infantry plans to fight in a DEWs environment. Some attention has been given to operational and organizational plans for laser weapons, but these plans are for future systems which have yet to be fielded. Much of the work regarding the impact on DEWs combat awaits the results of the Forward Area Directed Energy Weapons (FADEW) study being conducted by TRASANA. The results of this study should help to define the role of DEWs in tactical warfare in the future.

The issue of how the Army will fight in a DEWs environment today with current assets against a force which has fielded DEWs has been largely ignored. This is a major shortfall in Army preparation. Some recent efforts have been made to address this issue but such efforts can only be described as preliminary with no results. The scope of the effort concentrating on the DEWs problem should be dramatically increased so that all training and doctrine will reflect current DEWs issues.

It is suggested that a working group charged with responsibility to address the central issues of how the infantry is going to fight and train for a DEWs war be created at the USAIS. One of the vehicles to develop a working hypotheses should be a worst case scenario (i.e., that the materiel countermeasures which are currently being developed are unavailable or are ineffective). This is not unrealistic because such a situation may arise due to unanticipated delays in the development and fielding of countermeasures, unexpected early fielding of DEWs by threat forces, or the possibility that countermeasure capabilities were lost or ineffectual in combat. Infantry units must have contingency plans to carry on the battle in a DEWs environment; otherwise, they could sustain unnecessary and casualties or mission failures. The challenge to the proposed work group would be to address how the US forces should face an enemy with DEWs using currently available assets rather than relying on something that will have to be developed and fielded in the future.

Because this group would be viewed as the DEWs experts at the Infantry School, there would be a tendency to require this group to address peripheral DEWs issues as well. (Peripheral DEWs issues being any DEWs issues which are

not combat relevant to the infantry.) Most of the current efforts of DOTD, USAIS, have been related to essential, but peripheral issues. These have included, for example, developing testing issues for development/operational testing of weapon systems or safe window cleaning procedures. Such work must certainly be continued because it is an essential part of the materiel acquisition process, but this should not be at the expense of the central issue of preparing the infantry for combat in a DEWs environment. Consequently, it is recommended this group be given the authority to refuse to act on the peripheral issues until the central issues are addressed as part of its charter. Given the high workload of DOTD, USAIS, and related directorates plus the limited resources available, it is recognized that establishing this group would be very difficult to accomplish.

There is Difficulty Establishing "Facts" Regarding DE Related Issues

A fundamental problem facing the Army is ascertaining the facts about DE. Time and again during the course of this analysis different contradictory "facts" about DEWs and what the Army is doing concerning DEWs were presented. There are several causes for this. Foremost is the unique nature of DE. Many of the DEWs phenomena have never been thoroughly researched, and thus leave many questions unanswered. Secondly, the DEWs technology, specifically hardware, is new and untested; consequently, the ranges and capabilities of such systems are unknown. These facts, in turn, produce disagreements by experts in this field as to what is possible. Thus, it is difficult for users to know how to formulate DEWs tactics, doctrine, and training. Also, there has been an upgrading and compartmentalization of security classifications in some significant DEWs areas. This makes it even more difficult to anticipate what effects DEWs will have on certain systems. Therefore, little work can be done to develop nonmateriel countermeasures. To deal with this issue, it is recommended that future trainers involved with advanced DEWs training have Top Secret security clearances so their work can be guided by the most recent technological advances and that trainers work closely with the labs that are doing the actual research.

The User Community May Be Generally Overly Optimistic About Materiel Solutions to the DEWs Problem

Another point of concern is that the user community, unless otherwise educated, may have an overly optimistic view about potential materiel solutions to the DEWs problem. There is a tendency to assume countermeasure agencies are doing more than is actually the case. Several times during the course of this analysis the author was directed to different labs "who were working on that problem." Once the labs were contacted, the scope of their work was found to be much narrower than implied by others. The misconceptions are of four types: (1) the probable capability of countermeasures to protect systems, (2) little appreciation for the trade-offs involved with materiel solutions, e.g., performance degradation and weight penalties, (3) the expected time-frame availability of some of the materiel solutions, and (4) the extensiveness of the DEWs protection since not all weapon systems will be DEWs hardened and not

all subsystems of a particular system will be hardened. The reality of the situation is materiel solutions will help but only partially.

This is not intended to be a criticism of materiel developers. They have undertaken major challenges in unexplored areas with undeveloped technologies and have been able to produce some types of protection. This is no small feat. In some ways, remarkable progress has been achieved in a relatively short period of time. Nevertheless, the basic message to the user community must be not to expect miracles from the development community. Their contribution is significant but partial; the remainder of the challenge must be placed on the user community to develop tactics and training to maximize the contributions of the materiel developers and to further adjust conventional tactics and training to fight a DEWs war.

Concluding Remarks

DEWs have brought a new dimension to the modern battlefield and have necessitated a complete review of how the Army will fight the next war. This involves all levels of Army preparation from AirLand Battle 2000 to how troops should dismount a vehicle in combat. Certainly some of the solutions to this new challenge will come from the materiel development community in the form of countermeasure devices. However, the contributions of the materiel developers will not be total; the remainder of the challenge must be placed on the user community (e.g., TRADOC, FORSCOM units) to develop tactics and training to maximize the contributions of the materiel developers and to adjust conventional tactics and training to fight a DEWs war. Research regarding DEWs affecting weapon systems under different tactical conditions needs to be completed to identify the best possible tactical countermeasures. As these countermeasures are identified, they should be incorporated into soldier training. The materiel developers have already been working on these issues and it is now time for the user community to get involved.

REFERENCES

- Beavers, P.H., & Bradley, B. W. (1984). A review of high powered microwave technology. Aberdeen Proving Ground, MD: US Army Materiel Systems Analysis Activity (Secret).
- Struck, B. E. (1980, October). Multiwavelength laser threats. Proceedings of Combat Ocular Problems Conference. Presidio of San Francisco: Letterman Army Institute of Research.
- US Army Combined Arms Center (1982). Directed energy capstone manual. Fort Leavenworth, KS: Author (Secret/No Forn).
- US Army Foreign Science and Technology Center (1982). Letter report: Directed energy weapon threat (AST-2700R-100-82). Charlottesville, VA: Author (Secret/No Forn).
- Wolfe, J. A. (1983). Laser exposure of the human foveomacular petina and its effects on visual function. Presidio of San Francisco, CA: Letterman Army Institute of Research (Secret).

APPENDIX A

Suggested Outline POI for Directed Energy Training Program

- I. DIRECTED ENERGY - INTRODUCTION
 - Lasers
 - Radio Frequency Weapons
 - Particle Beams
- II. ADVANTAGES AND DISADVANTAGES OF DEWs
- III. KEY CONCEPTS
 - A. Electromagnetic Waves
 - B. Continuous Nature of Electromagnetic Spectrum
 - C. Soft Kill vs. Hard Kill
 - D. In-Band/Out-of-Band and Front-Door/Back-Door Penetration
 - E. Determining Power of DE Beam
- IV. LASERS
 - A. History of Lasers
 - B. How They Work (Light Amplified by Stimulated Emission of Radiation)
 - C. Impact of Lasers on Targets
 - 1. Bioeffects of Lasers
 - 2. Electro-Optical Systems
 - 3. Soft Targets
 - a. Aircraft
 - b. Missiles
 - c. Precision Guided Munitions (PGMs)
 - D. US Laser Systems
 - 1. Current Lasers
 - 2. Low-Power System
 - 3. High-Power Systems
 - 4. Future Systems

E. Threat

1. Current Lasers
2. Low-Power Systems
3. High-Power Systems
4. Future Systems

F. Effects of Smoke

G. Effects of Weather

1. Atmospheric Effects (Scintillation)

- a. Optical Turbulance
- b. Absorption and Scattering
- c. Wind
- d. Temperature

2. Rain

3. Snow

4. Fog

5. Dust

H. Effects of Vegetation

I. Effects of Reflective Surfaces

1. Specular Reflection (Shiny Surfaces)

- a. Metal Surfaces
- b. Glass on Buildings

(1) Outside of window

(2) Inside of window

2. Diffuse Reflection (Walls, Trees, etc.)

IV. LASER COUNTERMEASURES

A. Hardware

1. Individual Eye Protection

2. Filters

- a. For Future Systems
- b. For Existing Systems
- c. Damage Protection/Signature Reduction
- d. Broadband Neutral Density Filters
- e. One Color Notch and Broadband Cutoff Filters
- f. 3-Notch Color Filter

3. Smoke as Countermeasure

4. Other Options

- a. Shutters
- b. Shrouds
- c. Harden Glass
- d. Reflective Paint

B. Field-Expedient Countermeasures

C. Testing for Laser Damage

D. Tactical and Training Implications

- 1. Designed Scout
- 2. Hit Him Before He Hits You
- 3. Stay Out of Line of Sight
- 4. Kick Up Dust
- 5. Extensive Cross Training

V. COUNTER-COUNTERMEASURES

A. US

B. Threat

C. Future Projections

VI. ELECTROMAGNETIC PULSE (EMP)

A. Nuclear EMP

B. US Programs

C. Threat Programs

D. Tactical and Training Implications

VII. MICROWAVES

A. History of Microwave R&D

B. Physical Principles of Microwave Radiation

- 1. Characteristics of Microwaves
- 2. Microwave Generation

- C. Microwave Radiation Effects on Tactical Targets
 - 1. Personnel
 - 2. Electronic Equipment
- D. US Microwave Radiation Weapons Programs
 - 1. Tactical Concepts
 - 2. Development Programs
- E. Threat Microwave Emitter Projects
 - 1. Weapons Concepts
 - 2. Biological Effects Research
 - 3. Microwave Technology
- F. Protective Hardware and Methods
- G. Battlefield and Training Implications
 - 1. The Impact of Microwave Weapons on the Battlefield
 - 2. Training With High Power Microwaves

VIII. PARTICLE BEAM WEAPONS

- A. History of Particle Beam R&D
- B. Physical Principles of Particle Beam Weapons
 - 1. Particle Acceleration Technology
 - 2. Particle Beam Propagation
- C. Particle Beam Effects on Tactical Targets
- D. US Particle Beam Weapon Programs
 - 1. Particle Beam Concepts and Programs
 - 2. Particle Beam Accelerators
- E. Threat Particle Beam Projections

IX. COMBAT DEVELOPMENTS

- A. US Doctrine
- B. Threat Doctrine

C. Tactics and Techniques

1. Movement

a. Movement when not in contact

(1) Traveling

- (a) Mounted**
- (b) Dismounted**

(2) Traveling overwatch

- (a) Mounted**
- (b) Dismounted**

(3) Bounding overwatch

- (a) Mounted**
- (b) Dismounted**

b. Movement after contact is made

2. Offense

a. Actions on contact

- (1) With vehicles leading**
- (2) With dismounted infantry leading**

b. Closing with and destroying the enemy

c. Consolidation and reorganization

d. Attacks in built-up areas

e. Night/limited visibility operations

3. Defense

a. Against a mounted attack

b. Against a dismounted attack

c. Disengagement and withdrawal

d. Defensive in built-up areas

e. Night/limited visibility operations

X. TRAINING ISSUES

A. Safety

1. Range Safety

- a. Firing limits**
- b. Firing fans**
- c. Range preparation**

- (1) Controlled accesses**
- (2) Downrange clearance**

- (a) Personnel**
- (b) Wildlife**

2. Equipment and maintenance procedures

B. Medical Procedures

C. Importance of Identification of Friendly Forces (IFF)

D. Training Devices

E. Psychological Implications of DEWs

APPENDIX B

Crew performance of a M2 Bradley under simulated laser attack: a pilot study

Introduction

The advent of directed energy weapons (DEWs) has brought a host of new tactical and training challenges. One potential DEW is a low-power laser which could jam optical and electro-optical systems at tactical ranges and flashblind or permanently blind soldiers at closer ranges. A laser weapon could blind an individual looking through a direct view optic, such as a TOW sight, with virtually no damage to the combat potential of the vehicle. This is a rather unique phenomena of DEWs. Prior to DEW only chemical and biological weapons were capable of inflicting casualties with little or no damage to the vehicle. Most conventional weapons would have had to destroy or significantly damage a vehicle enroute to injuring the personnel inside. However, a major difference between chemical weapons and lasers is that chemical weapons affect all unprotected individuals in the vehicle equally while lasers injure only the crew members directly exposed to it.

Thus, in laser combat there will be a number of fully functioning vehicles with injured personnel filling critical positions, while at the same time there may be uninjured personnel in the vehicle.

Another aspect of an in-band laser injury is that it will be relatively painless and sensory debilitating only; there will be no need for immediate first aid beyond removing the individual from a hazardous position and making him comfortable. This would allow uninjured personnel immediately to assume the combat position of the wounded soldier. The most significant danger of a laser injury would be that the soldier might panic and act counterproductively in the midst of a crisis, thus endangering himself and his crewmates.

This implies the need for several training considerations regarding laser combat. First is the need for more crosstraining of crew members. Crew members

usually assigned to lower priority tasks will have to be trained in higher priority tasks, e.g. loader-gunner, infantryman-driver to allow the vehicle crew to maintain its combat effectiveness. Secondly, soldiers will have to learn to exchange places with one another quickly in order to minimize their vulnerability in combat and enhance their mission capability. Finally, there is a need to desensitize troops to DEWs and DEW-type injuries to prevent panic.

The purpose of this pilot study was to: (a) ascertain the approximate downtime of the M2 Bradley Infantry Fighting Vehicle (BIFV) when critical crew members are injured; (b) determine if practice in exchanging places with simulated crew injuries can reduce the downtime; (c) monitor the psychological reactions of the troops to DEWs; (d) determine whether this direction of training research and development holds promise of meaningful performance payoffs given additional time and resources.

Method

A Bradley squad consisting of the M2 vehicle and nine crew members: a Bradley commander (BC) and gunner in the turret, a driver, and six infantry men sitting in the troop compartment who would serve as test subjects. Two such squads were tested individually.

For the purposes of this study the BC, gunner, and the driver were designated as critical crew members who would have to be replaced if they became DE casualties. There are seven different possible combinations of casualties, given the three critical crew positions, which are:

1. Driver only
2. BC only
3. Gunner only
4. Driver, BC, and gunner.
5. Driver and BC
6. BC and gunner

7. Driver and gunner

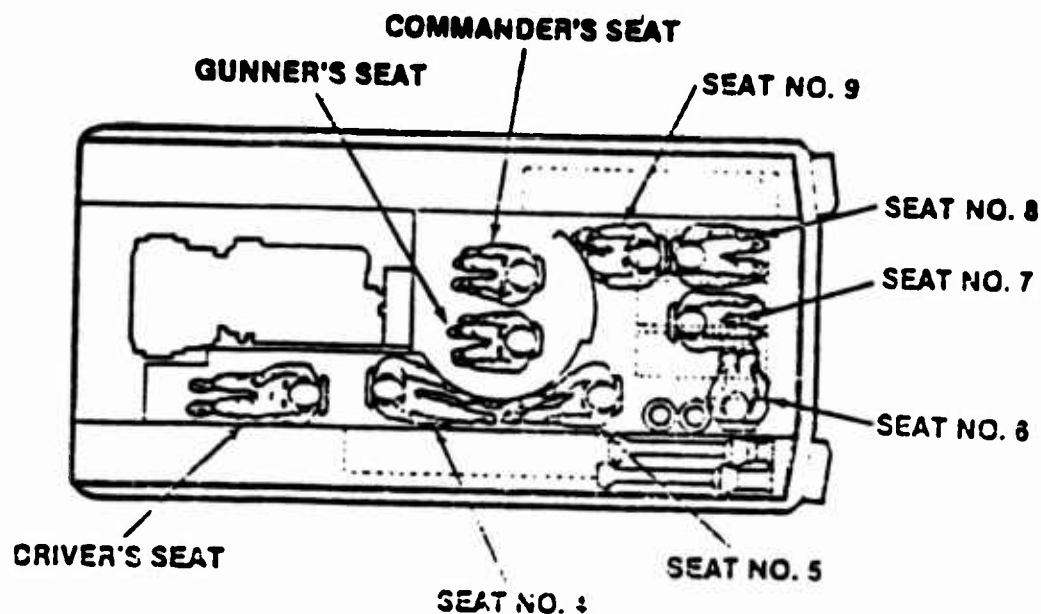

Figure 1. Seating in BIFV.

The experiment used eight soldiers in MOPP gear in a fully-loaded Bradley moving at combat speeds over a field. One experimenter rode in the vehicle in the number eight position as an observer. A second experimenter, stationed at a radio in the field, acted as a timekeeper and experiment controller. The BC, driver, and gunner were allowed to remove their protective masks to enable them to hear the controller.

Two different squads were utilized on subsequent days. The first day's squad was instructed not to discuss the purpose or nature of the exercise in order to limit any inadvertent learning by the other squad. Both squads were from Ft. Benning's resident Bradley support company and were experienced with the BIFV but none of the troops had any previous exposure to DEWs.

Experiment I Procedure:

The driving course to be traversed during the experiment was on the perimeter of a relatively flat field with one sharp slope of approximately 30 degrees and five feet in height. There was one straightaway of approximately

245 m and another of approximately 187 m. Figure 2 is a map of the course. This course allowed acceleration to combat speeds during the straightaways followed by braking for violent left turns. The slope of the field, the constantly changing speeds, and the frequent sharp turns produced a rough ride which simulated a combat assault.

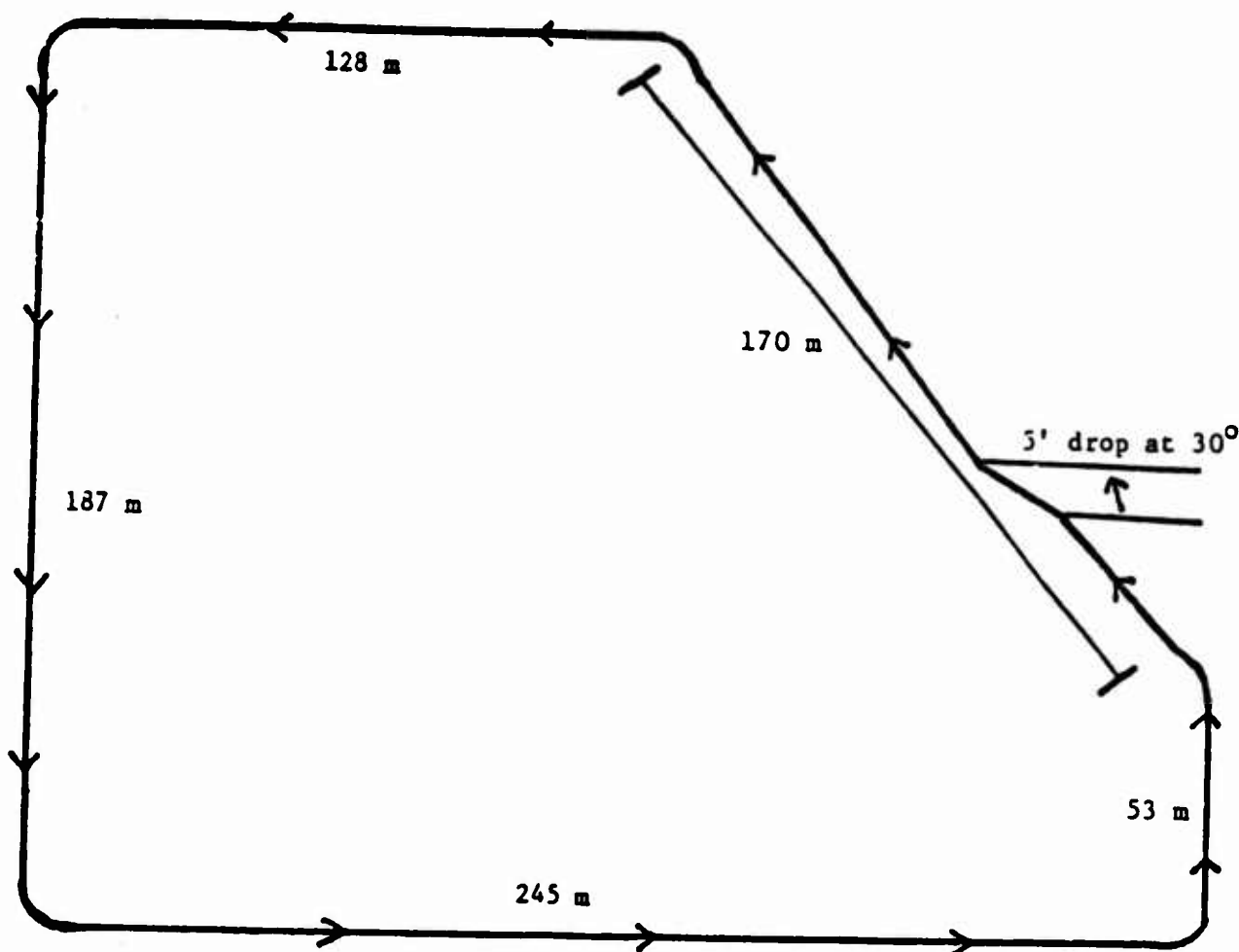

Figure 2. Experimental Course (approximate distances.)

Each crew was briefed on the purpose of the exercise: determination of the potential effects of a laser attack on a Bradley crew's performance. The crews were informed that in the future lasers could be used as weapons against them in combat. Injury from such a laser weapon would not cause pain but its blinding effects could be anything from instantaneous flashblinding to permanent

blinding. For the purpose of this drill they were instructed to assume that once they were told they were hit, they were to pretend they were blinded but they would feel no pain. Also they were not to recover until the end of each trial. To ensure compliance each victim was issued a pillow case and as soon as he was declared "blinded" he immediately covered his head. Finally, crews were informed that although such laser injuries could occur to just one crew member or a combination of crew members, for this exercise only the driver, BC, and gunner would be casualties. Before testing began the crews were encouraged to make preliminary contingency plans regarding replacing the three potential casualties.

For each trial these procedures were followed:

1. The crew was informed in advanced, in part as a safety precaution, of the intended victim. Noninjured personnel were instructed to ignore the radio transmission when the controller informed the victim he was blinded. The crew was to carry-on with its duties until advised by the victim of his injury.
2. The vehicle accelerated to combat speed and the turret was put in the three or nine o'clock position with respect to the front of the vehicle being in the 12 o'clock position;
3. The external controller announced on the radio to the victim that he was injured.
4. The victim immediately pulled the pillow case over his head and attempted to communicate to others that he was blinded.
5. Timing began as soon as there was any external evidence of an injury. Time started for the BC or the gunner as soon as the turret began to swing to the 12 o'clock position to exit the injured party. In a Bradley the main gun tube must be oriented forward to align the turret with the exit doors to the troop compartment interior. In the case of the driver, time started as soon as the vehicle began to slow down. When there was a combination of injuries to the

driver and turret personnel, whichever of the previous two occurred first was the signal to start timing.

6. Timing stopped when the vehicle began to regain speed or when the gun turret was reoriented to the original position with the appropriate new crew member(s) in place. With an injury to the driver and another soldier, the times of both events were noted. Such timing rules were used because these actions are what would be evident to an enemy who has lased a Bradley. The enemy would not know if he had been successful until there was some outside evidence of it.

Experiment II Procedure:

Experiment II was a stationary exercise designed to ascertain the relative contribution of vehicle movement on BC and gunner replacement times. If exchanging places while the vehicle was stopped was significantly faster than while it was moving, it might be expedient to completely stop the vehicle to replace injured personnel rather than to attempt to do it while the vehicle is moving.

The same procedures were used in Experiment I except that the vehicle remained stationary and therefore the driver did not participate.

Experiment III Procedure:

In combat there may be times when it would be better to verbally guide a blinded driver to drive to a defilade position instead of bringing the vehicle to a halt while exposed to hostile fire in order to replace the injured driver. This experiment was designed to ascertain how well a BC could guide a blinded driver through a course to a defilade position. The findings from this experiment could help determine the relative vulnerability between an immediate switch of drivers (in an exposed location) as opposed to the BC attempting to guide an injured driver to move the vehicle to defilade.

Figure 3 is a diagram of the Drive to Defilade Course. The vehicle was accelerated through the straightaway and the driver was "blinded". He

immediately pulled a pillow case over his head and timing was started. Timing stopped when the vehicle reached the defilade position.

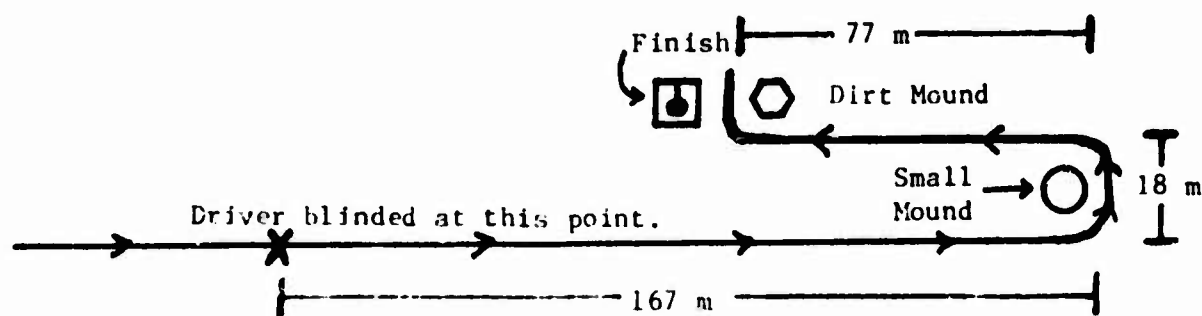

Figure 3. Drive to Defilade Course (approximate distance).

Figure 3. Drive to Defilade Course (approximate distance).

Experiment IV Procedure:

As the driver space was the most cramped position, physical size of the soldiers may have been a significant factor influencing the speed of exchange. This experiment attempted to ascertain the effects of the size of the drivers on the speed of the exchange.

Three different sets of drivers were used: (a) average size, experienced drivers, who participated in Experiment I (5'11"/146 lbs and 5'9"/160 lbs); (b) large size, inexperienced drivers, (6'8"/268 lbs and 5'11"/170 lbs); and (c) average size, inexperienced drivers, (5'11"/146 lbs and 5'9"/160 lbs).

In this experiment the vehicle remained stationary and the driver's hatch was open to allow the experimenter to observe and time the exchange. The drivers were instructed to make exchanges as quickly possible.

Results of Experiments I-IV:

Table 1 shows the results of Experiment I, downtime of the test BIFV.

Table 1. Times of Critical Position Exchange While Vehicle is Moving

Casualty	Squad 1		Squad 2	
	Trial 1	Trial 2	Trial 1	Trial 2
Driver	20	13	30	22
BC	a	25	42	16
Gunner	50	29 ^b	37	23
Driver, BC & Gunner	11 ^c /51 ^d	10/42	27/52	e
Driver, BC	16/38	15/28	23/23	e
BC, Gunner	77	50	49	e
Driver, Gunner	a	13/23	12/18	e

^aLost data

^bTemporary loss of turret power

^cVehicle began to regain speed

^dTurret was reoriented

^eVehicle deadlined

It was originally planned to have the squads complete three iterations of the drills. Unfortunately, due to scheduling and vehicle maintenance difficulties, all iterations were not collected. One crew participated in two iterations before the vehicle broke down and the one crew completed 1-1/2 iterations before the vehicle was deadlined due to a faulty turret shield door.

Table 1 shows the preliminary indications of improved performance from the

first to second trial in both squads. Also it should be noted that the driver-only performances are generally slower than when the driver was injured in combination with another critical crew member. This is due to the fact that timing started immediately when the driver was blinded alone. In the combination conditions, however, the driver was able to react early because timing was not begun until the turret began to rotate.

Table 2 shows the results of Experiment II, stationary exchange of turret personnel.

Table 2. Times of BC & Gunner Exchange While Vehicle is Stationary

Casualty	Trial (in seconds)	
	1st	2nd
BC	30	21
Gunner	20	27
BC & Gunner	46	35

NOTE: Squad 2 did not do Experiment II due to a deadlined vehicle.

As expected, turret personnel exchange was generally faster when the vehicle was stationary compared to when it was moving (see Table 1 vs Table 2) but this difference was not great.

Table 3 shows the results of Experiment III: drive to defilade.

Generally, drivers were able to cover the same course using sight in half the time it required them when they were blinded. Also the Squad 1 driver ended his first trial with one set of tracks on top of the dirt mound. In the following two trials he was very cautious and therefore had much slower times than the Squad 2 driver.

Table 3. Drive to Defilade Course Completion Times

Trial	Blinded			W/Vision	
	1st	2nd	3rd (in seconds)	1st	2nd
Squad 1 ^a	87	123	155	42	35
Squad 2	62	58	55	30	28

^aSquad 1 driver was excessively cautious on Trails 2 & 3 because ended on dirt mount on Trail 1

Table 4 shows the results of Experiment IV, the effect of driver size.

The size of the drivers appears to make little difference after some practice in the speed of driver replacement. The inexperienced average size drivers took much longer on trails 1 and 3 than the large size drivers because their clothing or equipment during those trials became snagged.

Table 4. Times of Driver Exchange While Vehicle is Stationary^a

Drivers	Trial			
	1	2	3	4
	(in seconds)			
Practiced ^b	18	16	--	--
Inexperienced				
Large Size	23	23	21	21
Inexperienced				
Average Size	38	21	26	19

^aSquad 2 only

^bDrivers who participated in Experiment 1

Discussion

No quantitative analysis of the above data was attempted because this was a pilot study and stringent experimental controls were not possible.

These times should be considered the lower limit of the performance potential for such exercises. These drills were held under optimal conditions and despite instructions to ignore the radio transmissions from the controller, other crew members could hear the controller. Thus they could prepare to take action before they were advised by the victim to do so. In addition, there was no competition for the crew's attention. They did not have other combat-related tasks to perform while participating in the experiment. Further, the noise level in the vehicle did not simulate combat conditions. There was little radio traffic, no concern about potential threats, and no weapons firing. All of these factors would make it more difficult for a victim under real combat

conditions to communicate the fact that he was injured. Nevertheless, some preliminary performance differences can be legitimately noted and there were a number of lessons learned.

The results suggest that improvements in crew exchange performances can be expected after just a few practice trials. A simple training program with potentially few sessions could produce asymptotic performance. This approach to training is low in cost and might reasonably provide high payoff in terms of sustained crew combat performance.

There was also a qualitative improvement of the techniques used by the crew members to assist injured personnel during the drills. For example, when the injured turret personnel initially exited the vehicle, they felt around to orient themselves. This sometimes involved hitting their heads against obstacles and tripping over items as the vehicle moved. By the end of the exercise, one squad developed a technique where an uninjured crew member would place one hand on top of the victim's helmet and grip the front of his shirt to guide the victim directly to his seat. All the casualty had to do was relax and follow the lead of his fellow crew member. In the case of an injured BC, the guide connected the commanders combat vehicle crew (CVC) intercom immediately so the wounded BC could communicate with the assistant squad leader. Such procedures were spontaneous and proved very efficient.

An unexpected finding was that the driver exchange was faster than the turret personnel exchange. It was originally hypothesized that since the driver's area was so cramped it would take longer for this casualty evacuation. The turret evacuation times were longer in part because the turret had to be reoriented for personnel to exit. This was especially difficult when both the gunner and the BC were blinded because other crew members had to yell through the turret shield door and instruct those inside to rotate the turret to the correct exit position. This proved difficult on occasion because there are no

markings on the interior of the troop compartment of the Bradley to indicate the current turret orientation to the crew compartment members. Consequently, on a few trials, crew members gave instructions to rotate the turret the "long way around". Some distinctive markings which can be seen from the crew compartment would alleviate the turret orientation problem.

Victims also used several phrases to indicate they were wounded: "I have been blinded", "I have been hit", "I can't see", "I've been lased", "I have been zapped". Of all of these, the term "zapped" appeared to have the most utility. Zapped unambiguously and succinctly denotes a particular type of injury. All soldiers in this experiment appeared to instantly know what is meant by this term. It is important to differentiate between laser blinding and a blinding caused by conventional weapons because different counteractions are indicated for each type of injury. Statements such as, "I can't see" could be interpreted to mean a person's vision was blocked by an obstacle or that the casualty was wounded by a conventional munition. In such cases other crew members may be tempted to offer assistance by looking in the same direction. This would not be the appropriate action in a laser environment because it would put the uninjured crew member in jeopardy. Secondly, the word "zapped" has a very distinctive sound which is not likely to be misunderstood for other words over the intercom. This is important because frequently there is a high blocking noise to sound ratio in the Bradley intercom system.

The results from Experiment I and Experiment II tentatively suggest that vehicle movement only slightly lengthens the time it takes to evacuate the turret casualties. The times of the turret personnel exchanges in Table 1 are little longer than the times in Table 2. Therefore if an injury occurs, it would appear to be better to continue movement while making an exchange. This would cost a few extra seconds but the vehicle could remain moving, therefore decreasing its vulnerability. It would also give less feedback to enemy DEW

gunners because they would not know if they had completed a successful attack.

The data from Table 3 indicates that it took almost twice as long for a blinded driver to be guided to a defilade position than for a sighted driver to travel the same distance with sight. This suggests that if a driver was wounded, it probably would put the crew in less jeopardy if he were immediately replaced by another driver than to attempt to verbally guide him to a defilade position.

Another issue arises from the previous recommendation which requires further consideration. When the drivers make an immediate exchange, the BC is taken out of the decision loop. There may be some circumstances when the commander may not want to do this. However, bringing the BC into the decision process will also increase the downtime of the vehicle. Additional research is needed to determine the relative cost/benefits of introducing the BC in the decision loop.

An observation not reflected in the data is the difficulty of the BC to verbally guide the blinded driver. This was especially obvious after about 30 seconds into the exercise as the BC got increasingly excited and gave the driver ambiguous instructions, e.g. "Turn now!, Turn now!" without indicating which direction to turn or how large of a turn was needed. Coordination between the driver and BC could certainly improve with some practice.

The findings from Experiment IV suggest that the driver's sizes and his replacement do not appear to have a significant effect on the speed of a driver exchange. There was only a small difference between the large and small driver exchange in this pilot test. The longest delays in the exchange of positions were due to articles of clothing getting snagged on equipment.

Some comments about the soldier's reactions to this experiment are appropriate at this point. Most had never participated in any crew extraction drills previously and all agreed such drills should be part of training even

independent of a laser threat.

Secondly, there appeared to be a shift in their attitude towards DEWs. This is a subjective observation that should be verified by more detailed empirical research. However, when both crews were initially briefed as to the purpose of the experiment and to the possibility of confronting a threat laser weapon in combat, they appeared to be quite serious. They listened very attentively, made few jokes, and asked few questions. When the experiment began they also had some difficulty announcing that they were "blinded". There was some hesitation in their voices and a struggle to choose the right words. However by the time the exercise was completed the soldiers appeared to be much more comfortable with the reality of laser weapons. The troops were freely talking about lasers and laser capabilities. Occasionally there were some jokes about lasers, but they no longer struggled to announce they were "blinded". They were able to participate in this exercise as they would in other conventional weapon exercises. It is the author's opinion that the free talking and jokes about lasers are evidence that the soldiers were psychologically assimilating the reality of DEWs.

Certainly, much of the above could be explained by non-DEW factors, such as this was an experiment with "scientific" observers and the troops were initially uncomfortable in that situation. Still it is hard to believe that some psychological desensitization did not occur as well. This assertion will have to be verified by additional empirical research. Lasers are shocking weapons and the thought of being blinded can be terrifying, but so are many other weapons and related battlefield injuries. Soldiers have been trained to fight against machineguns, tanks, and chemical weapons without panic. There is no reason to believe the same would not be true of lasers given a proper training program. Drills such as these could go a long way in psychologically preparing soldiers to respond efficiently in a DE combat environment.

Conclusions

This research suggests that practicing extraction procedures could reduce the down time of a M2 crew under laser attack. It also suggests the term "zapped" has utility and can communicate a very specific type of injury requiring a specific crew response; that is, injured crew members would be extracted while the remaining sighted members would exercise caution regarding sights and viewing ports. Further, this research indicates some decision rules can be developed regarding the most appropriate response to a laser attack. Finally, there appeared to be some reduction in the anxiety level of the troops regarding DEWs after they participated in this study.

Much additional research needs to be conducted regarding the training of tactical responses to DEW attacks. First of all, the same study with a larger sample size and better experimental controls is needed to verify the limited findings noted in this study. Secondly, crew drills for other vehicles need to be developed and specific decision matrices established. The findings from this study may not generalize beyond the M2. For example, based on the results of this pilot study it appears better to immediately remove an injured driver rather than to verbally guide him to defilade in an M2; the same may not be true in an M1 tank. Also this research involved one squad in almost ideal conditions of isolation. There may be other tactics at the platoon or company level that should be explored. Another question that needs investigation is the effects of having the BC introduced into the decision loop before driver exchange is executed. Further, only a few of the crew members were injured in this drill and there are other potential casualty combinations which should be tested as well. There is the need to explore what happens while the Bradley fights in a defensive position, during an attack, and when the infantry element dismounts. Different ways to generate dust clouds as a countermeasure against lasers would also be fruitful research.

DEWs have brought a new dimension to the modern battlefield and have necessitated a complete review of how the Army will fight the next war. This involves all levels of Army preparation from Army 21 to how troops should dismount a vehicle in combat. Certainly some of the solutions to this new challenge will come from the materiel development community in the form of countermeasure devices. However, the contributions of the materiel developers will not be total; the remainder of the challenge must be placed on the user community (TRADOC and FORSCOM) to develop tactics and training to maximize the contributions of the materiel developers and to adjust conventional tactics and training to fight a DE war. Research regarding DEWs affecting weapon systems under different tactical conditions needs to be completed to identify the best possible tactical countermeasures. As these countermeasures are identified they should be incorporated into soldier training as soon as possible. The materiel developers have already been working on these issues and it is now time for the user community to get involved as well.

APPENDIX C

Washington Post Article
Saturday, December 17, 1983

Laser Weapon Sparks Debate Over Ethics By Michael Schrange

The Army has developed a portable weapons system that uses laser beams to blind enemy soldiers in close-range combat, according to defense industry officials.

Plans for further development of the controversial weapons system already appear to have touched off debate within the Army over the probable public reaction once the purpose of the weapon becomes known.

The system, called C-CLAW for Close Combat Laser Assault Weapon system, would use low-power lasers to blind both the human eye and machine optical sensors, such as tank periscopes, at distances of up to a mile. The portable laser beam would sweep back and forth across a battlefield blinding anyone who looked directly at it.

"C-CLAW is under development and is going to be handled by Army Missile Command," says an Army spokesman. "But what it does and how it works is classified. It would be a close combat assault weapon to be used as a 'force multiplier.'" He conceded that continued funding of C-CLAW has caused significant internal dissent in Army circles because of the nature of the weapon.

Officially, however, the Army denies there are any ethical qualms about C-CLAW.

C-CLAW supporters argue that a laser weapon is "odorless, quiet and deadly at a distance." For example, a Warsaw Pact tank commander using a nightscope to survey a potential battlefield could be quietly blinded from more than a mile away by C-CLAW. A disciplined laser weapons approach, they argue, could cripple both man and machines blind, and would be an effective "instrument of terror" to ground forces.

US "threat assessments" of Soviet combat capability now assert that the Warsaw Pact will soon deploy C-CLAW-type systems, according to one source.

The program is part of an Army initiative launched earlier this year to establish a combat "directed energy program" embracing the new emerging technologies of lasers, particle beams and microwaves. "The majority of development funding is directed to low-energy lasers that cause blinding," according to an Army source.

Essentially, when laser light hits the eye, "the eye focuses the energy by a very significant factor-about 100,000 times," according to Colonel Edwin F. Beatrice, who heads the division of ocular hazards at the Army's Letterman Research Institute in San Francisco. Should that intensified light strike the eye's fovea, or optic nerve, a phenomenon known as photocoagulation occurs, there is a "vitreal hemorrhage" and the eye is flooded with blood. The effect, according to Beatrice, is "irreversible."

One major technical weakness of low-power lasers is that rain or fog could interfere with the light beam and effectively render the weapon useless.

The C-CLAW program is by far the closest to formal prototyping and production of a number of directed energy systems being researched. In 1982, the Army authorized a feasibility program known as "Roadrunner" to put a C-CLAW on an M2 Bradley Tank. Now, says an Army spokesman, Roadrunner is "the only directed energy system concept in an integrated system demonstration phase."

Ultimately, the Army said it would like to integrate C-CLAW into tanks, light armored vehicles and helicopters. The Army requested \$14 million in fiscal 1984 to fund C-CLAW, primarily for Roadrunner, according to the publication Defense Industry Report, and is expected to request \$20.4 million for the coming fiscal year.

Lasers, an acronym for Light Amplification by Stimulated Emission of Radiation, can emit a beam of coherent light that carries far more energy than the diffused light that shines from ordinary bulbs or fluorescent lamps. The energy of the beam depends upon its wavelength and the duration of the laser pulse.

Lasers have long been thought of by war planners as a valuable military weapon. High-energy lasers could, technically, burn holes in tanks and ships and planes. The Reagan administration is now exploring the potential of high-powered satellite lasers that could intercept and destroy land-launched ballistic missiles from outer space.

The difficulty there, says scientists and engineers, is that high-energy lasers require enormous amounts of power and the physics of their beam transmission is not well understood. C-CLAW, on the other hand, uses low energy lasers that require relatively little power. Furthermore, the biomedical effects of laser light on the human eye are well understood.

According to a 1981 study by the Army's Combat Analysis Agency, a soldier in a firefight facing low-level laser weapons stood a "better than 100 percent chance of being illuminated" - that is, being stuck by laser light. Actual casualty estimates are classified.

The Army currently uses laser beams as rangefinders for both the M60A3 and M1 tanks and, according to one Army source, these laser rangefinders served as the inspiration for the C-CLAW program. "We got into this almost by accident," he says. "The M1 laser rangefinder, which uses a 100 millijoule laser, would be combat effective now. It is the heart of the C-CLAW."

The Letterman Institute, the Natick Laboratories in Massachusetts and the Army's Night Vision Laboratories in Fort Belvoir, Virginia, are all working on development of "broad-band filters" for soldiers to wear to screen out harmful laser light of varying wavelengths and pulse intensities. The problem with existing laser filters, says one scientist, is that "the soldier may be protected from laser light but he can barely see anything else."