

DTIC FILE COPY

2

AD-A179 743



TECHNICAL REPORT RD-TE-87-1

ELECTROMAGNETIC ENVIRONMENTAL CRITERIA FOR
US ARMY MISSILE SYSTEMS: EMC, EMR, EMI, EMP,
ESD, AND LIGHTNING

Mark Kilpatrick
Test and Evaluation Directorate
Research, Development, and Engineering Center

Charles D. Ponds
Colsa, Inc.

DTIC
ELECTE
APR 30 1987
S D
D

FEBRUARY 1987



U.S. ARMY MISSILE COMMAND

Redstone Arsenal, Alabama 35898-5000

Approved for public release; distribution is unlimited.

DISPOSITION INSTRUCTIONS

**DESTROY THIS REPORT WHEN IT IS NO LONGER NEEDED. DO NOT
RETURN IT TO THE ORIGINATOR.**

DISCLAIMER

**THE FINDINGS IN THIS REPORT ARE NOT TO BE CONSTRUED AS AN
OFFICIAL DEPARTMENT OF THE ARMY POSITION UNLESS SO DESIGNATED
BY OTHER AUTHORIZED DOCUMENTS.**

TRADE NAMES

**USE OF TRADE NAMES OF MANUFACTURERS IN THIS REPORT DOES
NOT CONSTITUTE AN OFFICIAL INDORSEMENT OR APPROVAL OF
THE USE OF SUCH COMMERCIAL HARDWARE OR SOFTWARE.**

REPORT DOCUMENTATION PAGE

Form Approved
OMB No 0704-0188
Exp Date Jun 30, 1986

1a. REPORT SECURITY CLASSIFICATION Unclassified		1b. RESTRICTIVE MARKINGS	
2a. SECURITY CLASSIFICATION AUTHORITY		3. DISTRIBUTION/AVAILABILITY OF REPORT Approved for public release; distribution is unlimited.	
2b. DECLASSIFICATION/DOWNGRADING SCHEDULE		5. MONITORING ORGANIZATION REPORT NUMBER(S)	
4. PERFORMING ORGANIZATION REPORT NUMBER(S) RD-TE-87-1		7a. NAME OF MONITORING ORGANIZATION	
6a. NAME OF PERFORMING ORGANIZATION Test and Evaluation Directorate RD&E Center	6b. OFFICE SYMBOL (if applicable) AMSMI-RD-TE	7b. ADDRESS (City, State, and ZIP Code)	
6c. ADDRESS (City, State, and ZIP Code) Commander US Army Missile Command ATTN: AMSMI-RD-TE Redstone Arsenal, AL 35898-5250		9. PROCUREMENT INSTRUMENT IDENTIFICATION NUMBER	
8a. NAME OF FUNDING/SPONSORING ORGANIZATION	8b. OFFICE SYMBOL (if applicable)	10. SOURCE OF FUNDING NUMBERS	
8c. ADDRESS (City, State, and ZIP Code)		PROGRAM ELEMENT NO.	PROJECT NO.
		TASK NO.	WORK UNIT ACCESSION NO.
11. TITLE (Include Security Classification) Electromagnetic Environmental Criteria for US Army Missile Systems: ENC, EMR, EMI, EMP, ESD, and Lightning			
12. PERSONAL AUTHOR(S) Mark Kilpatrick and Charles D. Ponds			
13a. TYPE OF REPORT FINAL	13b. TIME COVERED FROM _____ TO Oct 86	14. DATE OF REPORT (Year, Month, Day) FEBRUARY 1987	15. PAGE COUNT 61
16. SUPPLEMENTARY NOTATION			
17. COSATI CODES		18. SUBJECT TERMS (Continue on reverse if necessary and identify by block number)	
FIELD	GROUP	Electromagnetic Radiation (EMR)	
		Electro Static Discharge (ESD) (continued on page 11)	
		Lightning	
		Electromagnetic Pulse (EMP)	
19. ABSTRACT (Continue on reverse if necessary and identify by block number) This report presents the design and test requirements in developing an electromagnetic compatibility missile system. Environmental levels are presented for electromagnetic radiation hazards, electrostatic discharge, lightning, and electromagnetic pulse (nuclear). Testing techniques and facility capabilities are presented for research and development testing of missile systems.			
20. DISTRIBUTION/AVAILABILITY OF ABSTRACT <input checked="" type="checkbox"/> UNCLASSIFIED/UNLIMITED <input type="checkbox"/> SAME AS RPT. <input type="checkbox"/> DTIC USERS		21. ABSTRACT SECURITY CLASSIFICATION UNCLASSIFIED	
22a. NAME OF RESPONSIBLE INDIVIDUAL Mark Kilpatrick		22b. TELEPHONE (include Area Code) 605-876-3415	22c. OFFICE SYMBOL AMSMI-RD-TE

Continued from page 1, block 18.

Electromagnetic Compatibility (EMC)

Electromagnetic Interference (EMI)

Electromagnetic Radiation Hazard (EMRH)

Electromagnetic Radiation Operational (EMRO)

TABLE OF CONTENTS

	<u>Page</u>
I. INTRODUCTION.....	1
A. Purpose.....	1
B. Definitions of Terms.....	1
C. Free Space EM Field versus EM Field in a Screen or Shield Room.....	2
II. HIGH-LEVEL EM ENVIRONMENTAL CRITERIA.....	3
A. Background.....	3
B. Criteria Development Procedure and Rationale.....	4
1. EMRH Criteria.....	4
2. EMRO Criteria.....	7
3. ESD Criteria.....	8
4. Lightning Criteria.....	10
5. EMP Criteria.....	12
III. MISSILE TESTING TECHNIQUES.....	14
A. Introduction.....	14
B. MICOM EMC Evaluation Program.....	14
1. Subsystems Level Tests.....	14
2. Systems Level Tests.....	15
REFERENCES.....	52

LIST OF FIGURES

<u>Figure</u>	<u>Title</u>	<u>Page</u>
1	Direct strike idealized current test waveform.....	28
2	EM test area.....	29
3	EMC evaluation program.....	30
4	Electrostatic discharge (ESD) generator (0-30 kV dc).....	31
5	EMI test instrumentation room.....	32
6	EMI test area room.....	33
7	EMP test facility.....	34
8	Typical EMP test instrumentation.....	35
9	ESD generator (0-300 kV dc).....	36
10	Instrumented ESD test.....	37
11	Direct lightning strike $\frac{\partial I}{\partial t}$	38
12	Direct strike test configuration.....	39
13	Direct strike current waveform.....	40
14	Frequency spectrum of measured direct strike current waveform.....	40
15	Injection current waveform for high peak current, direct strike tests.....	40
16	Frequency spectrum of high current, low frequency direct strike waveform.....	40
17	Plan views - nearby strike configuration and electrode strike.....	41
18	Electric Field measured at 10 meters (from oscillo- scope trace).....	41
19	Frequency spectrum of electric field measured at 10 meters.....	41
20	Typical direct strike instrumentation configuration.....	42
21	EMR test facility (aerial view).....	43

QUALITY
INSPECTED
1

<input checked="" type="checkbox"/>
<input type="checkbox"/>
<input type="checkbox"/>

Codes

Dist A-1	Avail and/or status
--------------------	------------------------

LIST OF FIGURES (Continued)

<u>Figure</u>	<u>Title</u>	<u>Page</u>
22	Transmitters (100 kHz to 10 GHz).....	44
23	Antenna system (100 to 350 MHz).....	45
24	Antenna (chamber) (100 kHz to 30 MHz).....	46
25	Antenna (350 MHz to 18 GHz).....	47
26	Block diagram of instrumentation of EMRH and EMRO.....	48
27	Test fixture - positioner.....	49
28	Receiving station and HP 1000 system.....	50
29	Instrumentation package (EMRO and EMRH).....	51

LIST OF TABLES

<u>Table</u>	<u>Title</u>	<u>Page</u>
1	EMRH Deployment Criteria for Army Systems.....	5
2	EMRH Shipping and Storage Criteria for Army, NATO, and Marines (Navy) Systems.....	5
3	EMRO Environment from Ground Communications Equipment (Prelaunch and Flight).....	7
4	EMRO Environment from Radars.....	8
5	ESD Criteria.....	9
6	Direct Strike Criteria.....	11
7	Electromagnetic Fields from Nearby Lightning (Cloud-to- Ground).....	13
8	Transmitter Systems.....	22

I. INTRODUCTION

A. Purpose

This report documents within one volume the electromagnetic (EM) requirements for missile systems to prevent associated problems when a system is in an EM environment. Also in this report there is an attempt to clarify the different EM test requirements placed on a system with an outline of the different tests and their application to the development cycle. The following EM test requirements are considered in this report:

- Electromagnetic Compatibility (EMC)
- Electromagnetic Interference (EMI) or radio frequency interference (RFI)
- Electrostatic Discharge (ESD)
- Electromagnetic Pulse (EMP)
- Electromagnetic Radiation Hazard (EMRH)
- Electromagnetic Radiation Operational (EMRO)
- Lightning (radiated electric and magnetic fields and direct strike)

B. Definition of Terms

The following definitions are used in this report:

- Electromagnetic Radiation (EMR) - The propagation of energy in the form of varying electric and magnetic fields through free space at the speed of light.
- EMRH Criteria - An EM environment to be used in the design, development, and verification of firing circuits, and the selection of all Electroexplosive Devices (EEDs) to preclude premature detonation of items during shipping, storage, handling, prelaunch, and launch. This includes also abortive functioning of the EED (dudding) and degradation of the reliability or performance characteristics of the EED.
- ESD Criteria - An electrostatic environment to be used in the design, development, and verification of electronic circuitry whose malfunction could create a hazard or affect system reliability. Both helicopter and personnel-borne charges are specified in these criteria.
- Lightning Criteria - An environment to be used in the design, development, and verification of electronic circuitry to insure safety and reliability. For the nearby strike, the system shall survive without permanent damage; for the direct strike, the equipment when exposed to the environment herein shall not provide energy to the Weapon System which would result in a hazardous condition. The system is not required to operate after being subjected to the environment.

● **Field Strengths** - A measure of electric (E) or magnetic (H) field potential in an electromagnetic field, usually expressed in volts per meter (V/M) and amperes per meter (A/M), respectively.

● **CW Fields** - A continuously successive oscillation of equal amplitude and wavelength, a root-mean-square (RMS) value.

● **Power Density** - The intensity of EMR present at a given point. Power density is the power per unit area expressed as watts per meter squared (W/M^2).

● **EMC** - A system is electromagnetic compatible when the EM environment causes no degradation to the system and the system does not degrade the environment. The hardening of a system to all the environments covered in this report provides an electromagnetic compatible system.

● **EMI or RFI** - An electromagnetic or radio frequency interference in or out of a component, subsystem, and system. This term is used in reference to screen or shielded room testing using MIL-STD-461 type tests.

● **EMP** - This is generally referred to as a pulse generated due to a nuclear burst. Sometimes the pulse from close lightning is also called EMP, but in this report EMP means the pulse generated from a nuclear burst.

● ***Free Space** - For the purpose of this report, a free space field, either the radiator or antenna, is in an open area with a minimum of material substances from which waves may be reflected.

C. *Free Space EM Field versus EM Field in a Screen or Shield Room

The environmental requirements and test methods for screen or shield room testing are established and are included in MIL-STD-461, -462, and -463. Because the free space environmental requirements and testing methods have not been published in a military specification, this report develops free space requirements and test methods for missile systems. A detailed discussion follows of a free space, or high-level EM environmental criteria, and testing techniques.

II. HIGH-LEVEL EM ENVIRONMENTAL CRITERIA

A. Background

With the introduction of either high-power electromagnetic radiation (EMR), or radio frequency (RF) emitters, or both, complex weapon systems including use of solid state and/or integrated circuitry and nuclear weapons, the Army has become increasingly aware of the problems associated with exposure of missile systems to high-level electromagnetic (EM) environments. To insure that missile systems can be safely handled and reliably operate in these environments, the Army has attempted to establish EM design and test criteria. The following is a history of this effort:

- The Office of the Adjutant General (TAG) published a letter, dated 7 June 1963, Subject: Electromagnetic Radiation (EMR) Objectives and Criteria for Nuclear Weapons, which established EMR criteria for nuclear systems. Because no criteria existed for conventional weapons, the same criteria were used. These criteria were used to test and evaluate weapon systems to determine their vulnerability to EMR. System safety was ascertained by determining if the system electro-explosive devices (EEDs) were degraded. Later, these criteria were applied to the evaluation of systems during an operational sequence; thus, system operational reliability was ascertained.

- A TAG letter, dated 22 April 1965, Subject: Program for Weapon Systems - Electromagnetic Radiation (EMR), Analysis and Control, was published and the 7 June 1963 letter was rescinded. The responsibility for establishing new criteria for weapon systems was placed on US Army Combat Development Command (CDC). These criteria were never developed. When Project Managers (PMs) requested EMR criteria, CDC directed the PMs to use the 7 June 1963 TAG levels.

- AMS Regulation 15-2, dated 27 April 1967, Subject: AMC Radio Frequency Radiation Effects Committee, enacted this committee; however, it is now inactive and failed to establish new EMR criteria.

- In January 1970 a Tri-Service Committee to establish criteria for certifying systems to EM fields was formed. Although some EMR criteria data were gathered by this committee, no MIL Standards were published.

- The US Army Missile Command, in a letter to US Army Material Command, dated 7 April 1970, established interim EM criteria for missile systems. The intent was to establish criteria that would be used until criteria were published. These interim criteria have been used and were slightly revised and published in an internal Technical Note RT-76-61, dated 18 May 1976, Subject: Electromagnetic (EM) Environmental Design and Test Criteria for Missile Systems including EM Radiation Hazards (EMRH), EMR Operational (EMRO), Electrostatic Discharge (ESD), and Lightning (excluding Nuclear EM Pulse). Subsequently, Internal Technical Note RT-76-61 was updated by Technical Reports ET-77-9 on 1 August 1977 and RT-81-5 on March 1981 and RT-85-14 on January 1985. This report updates and supersedes Technical Report RT-85-14.

- A draft Military Standard was published 25 July 1978, Title: Evaluation of Munitions to Electromagnetic Fields, Requirements For. This draft standard was sent to MIRADCOM for review and comment. Comments were sent back stating that the field strengths specified were unrealistically high and would have severe impact on development of MIRADCOM systems. It was requested that rationale be provided for review to support the proposed field strength levels. No additional information was ever received.

- A Military Handbook (MIL-HDBK-235) was published 5 February 1979, Title: Electromagnetic (Radiated) Environment Considerations for Design and Procurement of Electrical and Electronic Equipment, Subsystems and Systems. The intent of this document is not to provide detailed EM environments, since each system is somewhat unique, but, rather, to provide guidance. Information from this handbook has been evaluated and the field strengths are unrealistically high and would severely impact missile system development. The environmental requirements listed in this document for MICOM systems were established using engineering judgement in defining separation distances and probabilities of encountering high-powered emitters.

B. Criteria Development Procedure and Rationale

1. EMRH Criteria . The Criteria contained in TAG letter dated 7 June 1963, discussed above, has been used through the years for both Nuclear and conventional developers and Test and Evaluation Command (TECOM) has also used this Criteria for type classification of all systems. The EMRH Criteria in Table 1 are for system deployment and essentially the TAG Criteria except for some peak radar fields and low frequencies (.1 to .2 MHz).

The normal mode for igniting an EED is by applying a current through the bridgewire from pin-to-pin, thereby causing detonation by the heating action. The power to produce this heat may be calculated by squaring the current and multiplying it by the bridgewire resistance (I^2R). The normal firing mode is a heating phenomenon; thus, the continuous wave (CW) field strengths (RMS volts/meter) are of concern; however, EEDs can be ignited pin-to-case by a voltage breakdown through the chemical mix, and peak fields are of concern for this ignition mode. Since all systems have a nuclear electromagnetic pulse (EMP) requirement and most systems have the helicopter electrostatic discharge (ESD) requirement, then the effects of peak EMRH fields on the system is not instrumented and tested. Since most MICOM systems are candidates for marine and NATO agencies, Table 2 criteria are the criteria for transportation and storage for those MICOM systems. Table 2 is a combination of Army TAG, NATO and Navy MIL-STD-1385A environments. The minimum safety factors of 10 and 16.5dB for tables 1 and 2 respectively, shall be exhibited for an EED where premature initiation will result in injury to personnel or destruction of property and a minimum safety factor of 6 and 6.9dB for tables 1 and 2 respectively shall be exhibited for an EED whose premature initiation will result in an unacceptable degradation of weapon performance.

TABLE 1 - EMRH Deployment Criteria for Army Systems

Frequency (MHz)	Electric Average Volts (RMS)/meter	Field Peak Volts/meter	Polarization
.1 - .2	50	100	Vertical
.2 - .32	100	200	Vertical
.32 - 100	100	200	Vertical & Horizontal
100 - 1000	200	400	Vertical & Horizontal
1000 - 18000	200	20,000*	Vertical & Horizontal

* Design goal (not a test requirement)

TABLE 2 - EMRH Shipping & Storage Criteria for Army, NATO, & Marines (Navy) Systems

Frequency (MHz)	Electric Field Average Volts (rms)/meter	Polarization
.1 - .2	100	Vertical
.2 - .535	300	Vertical
.535 - 32	200	Vertical
32 - 100	100	Vertical & Horizontal
100 - 200	200	Vertical & Horizontal
200 - 225	275	Vertical & Horizontal
225 - 400	300	Vertical & Horizontal
400 - 950	239	Vertical & Horizontal
950 - 2700	612	Vertical & Horizontal
2700 - 3600	868	Vertical & Horizontal
3600 - 5400	612	Vertical & Horizontal
5400 - 6000	1228	Vertical & Horizontal
6000 - 7000	612	Vertical & Horizontal
7000 - 7900	612	Vertical & Horizontal
7900 - 8400	812	Vertical & Horizontal
8400 - 11000	1228	Vertical & Horizontal
11000 - 13000	612	Vertical & Horizontal
13000 - 16000	612	Vertical & Horizontal
16000 - 18000	612	Vertical & Horizontal
18000 - 40000	200	Vertical & Horizontal

The CW field strength criteria in Table 1, for the 0.1 to 100-MHz range, are based upon the highest power transmitters scattered through this frequency band. Weapon systems can be exposed to these fields when either transported, stored, or deployed. No attempt was made to identify specific narrow frequency bands in which only low-power transmitters are available, since the EED circuits have broadband sensitivity. The CW field strength is equivalent to the average field strength in the referenced 7 June 1963 TAG letter. As stated, these are environments that Army systems are expected to encounter. If the system under development is intended to be used by the Navy (Marines), then a worst-case combination of the Army and Navy environments should be used. The Navy environments are included in Military Standard 1385A (NAVY), dated 25 August 1982, Title: Preclusions of Ordnance Hazards in Electromagnetic Fields, General Requirements For.

The CW for Table 1, Army Criteria, on average field strength criteria above 100 MHz are based upon the maximum continuous personnel exposure of 10.0 mW/cm² as specified in TB-MED-523. Using far field theory, this level converts to 194 V/m and is rounded off to 200 V/m for the criteria. It is assumed that during transportation, storage, and deployment the EMR environment will be limited to the TB-MED-523 limit to protect personnel.

The peak field strengths in the frequency range up to 1000 MHz were determined by assuming a 25-percent duty cycle and using basic far field antenna theory. The relationship between peak power, average (RMS) power, and duty cycle as an example is:

$$P_A = \frac{E^2}{377} \quad (1)$$

where

E = electric field (V/M)

P_A = average power density (W/m²)

377 = intrinsic impedance of free space (far field)

From Table 1, E = 100 V/m for the 2 to 100-MHz range and P_A is calculated from Equation (1) as

$$P_A = \frac{(100)^2}{377} = 26.5 \text{ W/m}^2 \quad (2)$$

Duty cycle (DC) is defined as DC = P_A/P_P, where P_P is the peak power density (W/m²), then

$$P_P = \frac{P_A}{DC} = \frac{26.5 \text{ W/m}^2}{0.25} = 106 \text{ W/m}^2 \quad (3)$$

In addition, Equation (1) may be used to calculate peak field strength (E_p):

$$E_p = \sqrt{377 P_p}$$

or

$$E_p = \sqrt{377(106)} \tag{4}$$

$$E_p = 200 \text{ V/m}$$

The frequencies above 1000 MHz are considered to be in the high peak power radar band and a duty cycle of 0.0001 is assumed. Therefore, E_p may be calculated using 0.0001 duty cycle to give a value of

$$E_p = 20,000 \text{ V/m}$$

As stated previously, peak fields are not verified by EMRH testing since all systems have a nuclear EMP test requirements. Peak field levels are sometimes verified when a specific radar or radars are part of the weapon system. Then these intersystem radars are used in generating the test environments.

2. EMRO criteria, as given in Tables 3 and 4, are generally lower than the EMRH criteria because, during system deployment, the probability is low that the system will be operated near a high-power emitter; however, for the EMRH criteria, the weapon system is considered to be under worst-case conditions, and a potential hazard (e.g., a missile could be transported by high-power emitters). The EMRO criteria were developed using only military emitters, while military and civilian emitters were used in developing the EMRH criteria.

TABLE 3. EMRO Environment From Ground Communication Equipment (Prelaunch and Flight)

Frequency	Fields (V/m) (RMS) (V&H)		
	CW	AM	FM
100 kHz to 2 MHz	25	25	--
2 to 20 MHz	50	50	--
20 to 100 MHz	50	50	50
100 to 500 MHz	25	25	--
500 to 1000 MHz	50	50	--

NOTE: The above are average field strengths. AM will be tested using a square wave with 100% modulation, FM will be tested using +50 KHz deviation. The frequency of modulation for both AM and FM will be determined from the frequencies inherent to the system for system operation.

TABLE 4. EMRO Environment From Radars

Frequency	Fields (V/m) V&H	
	Peak	Average (PM)
400 to 9300	5000	50
9300 to 18000	2500	25

In calculating field strength for the EMRO criteria, the following emitter-weapon system separation distances were used:

- Mobile radios, 5 meters (m)
- Fixed and large antenna systems, 50 m
- Aircraft emitters, 150 m
- Friendly countermeasuring equipment, 10 m
- Portable radars, 300 m
- Permanently installed radar site, 1000 m
- FM Modulation - Most Army FM emitters transmit in the 20- to 100MHz band.
- AM Modulation - Army AM emitters operate throughout the 100-kHz to 1000-MHz band.
- Selected Modulation - Through experience in missile EMRO testing, it has been determined that the most susceptible modulations are related to frequencies inherent to the missile system, (e.g., clock frequency, gyro spin rate, etc.).
- Pulse Modulation - Most radars utilize pulse modulation transmission; a representative duty cycle was established at 0.0001. Peak levels up to the capability of broadband emitters are to be verified by test. Above this capability the requirements will be verified by either analysis or test, depending on practicality of performing tests. Usually specific radars will be required for testing to the very high peak fields.

3. ESD Criteria. The standard for testing fuzes to evaluate their safety and reliability under ESD conditions is MIL-STD-331, Electrostatic-Discharge Test. This standard is referenced only as a guide in establishing tests for missile systems ESD testing.

There are two criteria of concern when dealing with the handling of missile systems. One is the voltage potential buildup on a system when handled, disassembled, transported, etc., by personnel. This is sometimes called human buildup of electrostatic charge. The US Army Transportation Research Center, Fort Eustis, Virginia (1), performed measurement on the H-37, H-34, H-19, HU-1, and H-21 helicopters, and from these data a criterion has been established. These environments are summarized in Table 5, representing personnel handling and helicopter generated.

The system configurations which represent handling by personnel or being transported/deployed on a helicopter are very important. Usually the 25,000-v criterion is applied to points on the missile airframe, which represents ESD from a person to the missile. Normally, a system being transported by helicopter is in a container or launcher, and the 300,000 volts are applied to the container or launcher and then discharged through points on the system, which represent a discharge to electrical ground when coming in contact with electrical ground. In configurations where personnel with weapons being hand-carried are transported by helicopter, the 300,000 volts are applied with an additional 500 ohms resistor in series with the discharge path.

TABLE 5. ESD Criteria

ESD Environment		
Voltage	Capacitance (pF)	Series Resistance
Representing Personnel Handling*		
25,000 \pm 500	250 \pm 5%	500 \pm 5%*
Representing Helicopter		
300,000 \pm 500	1000 \pm 5%	500 \pm 5%**

* Personnel generated environment has been taken from the MIL-I-23659, however, Lightning and Transients Research Institute suggests changing the 500 pF to 250 pF, and the 5000 ohms to 500 ohms. Their studies indicate this better represents an equivalent circuit of a person from which static discharge may take place.

** Personnel with hand held weapons only, the 500 \pm 5% ohms is applied.

The objective of these tests is to determine if the weapon system can be reliably and safely handled and transported. During these tests, the weapon system is in a passive state and is evaluated on an instrumented and/or a go-no-go basis. The EEDs are checked for premature initiation or damage and a post-operational check is performed on the missile electronics. Thus, pass/fail criteria for the ESD environments include:

- a. Safety. There shall be no degradation of EED safety as a result of these tests.
- b. Reliability. There shall be no significant change in the operability of the system as a result of these tests.
- c. Pass-Fail Decision. The decision that the system has met or failed to meet the criteria shall be based on post-test inspection and appropriate tests of the system as well as engineering judgement and analysis.

4. Lightning Criteria. These criteria are divided into two categories, direct strike and close lightning (magnetic and electric fields). There is a lightning specification, MIL-STD-1757, which was derived from the SAE subcommittee AE4-L document on Lightning Test Methods and test wave forms for Aerospace vehicles, June 1968. The criteria herein has been established specifically for weapon systems.

- a. Direct Strike Lightning. The direct strike criteria are primarily required for weapon system safety and secondarily required to prevent permanent damage to system electronic components. The system is required to be safe from premature launch or detonation of hazardous items when struck by a direct strike having the parameters shown in Table 6 [2,3,4]. The cloud-to-ground direct strike criteria are required for all surface-to-air missiles. Figure 1 is an idealized current test waveform used for evaluation. The cloud-to-ground severe (worst-case) direct strike criteria shall not provide energy to the weapon system which result in a hazardous condition. Thus, after a direct strike of 200,000 amperes a weapon system is not required to be operational. The cloud-to-cloud direct strike criteria are required for weapon systems inflight that could cause a safety problem and/or causing flight failures. Thus, after a cloud-to-cloud direct strike of 20,000 amperes to a weapon system inflight is required to be operational.

- b. Close Lightning. The close lightning or lightning electromagnetic pulse (LEMP) criteria are required primarily for protection of EEDs and electronic components from detonation, burnout, destruction, etc. Large magnetic and electric fields are radiated from lightning strokes. It is highly desirable to design missile systems to withstand these environments during a launch sequence or when the electronics are active.

The close lightning environment is specified in terms of magnetic and electric fields and their rates of change.

TABLE 6. Direct Strike Criteria

Parameter	Cloud-to-Ground	Cloud-to-Cloud
	Severe (Worst-Case)	Severe (Worst-Case)
Number of strokes	2	3
Time intervals between strokes (msec)	60	30
Peak Current (first stroke) (kA)	200	20
Time to peak (all strokes) (μ sec)	1.5	1.5
Max $\partial I/\partial t$	2×10^{11}	2×10^{11}
Action integral $\int i^2 dt$ (A^2 Sec)	2×10^6	2×10^4
Peak current (subsequent strokes) (kA)	100	
Action integral $\int i^2 dt$ (A^2 sec) (subsequent stroke)	0.25×10^6	
Amplitude of continuing current (A) average	400	200
Duration of continuing current (msec)	400	700
Charge passing in continuing current (coulombs)	160	30
Charge per stroke (coulombs)	166	28, 1, 1
Total charge in flash (coulombs)	200	200
Flash duration (sec)	0.5	.90

The magnetic fields H at a distance R from the stroke are simply determined for the strike current I by letting $H = I/2\pi R$. Therefore the magnetic fields have the same shape as the current in Figure 1. Pertinent features of the magnetic field are summarized in Table 7. It is assumed that 10 m is the minimum distance a stroke can be from an object without striking it directly.

The electric field from nearby lightning is more difficult. The maximum field and its rate of change is associated with the approach of the stepped leader to the earth or to the system of interest. As the leader approaches, the electric field at the earth becomes large enough (6×10^5 V/m) such that a streamer forms at some pointed objects on the earth (or system) and travels upward to meet the downward coming leader. This occurs at an elevation of about 50 m. Thus, the static electric field is limited by air breakdown considerations, and its rate of change at the earth is determined by the leader velocity, the charge per unit length on the leader, and the height of the leader tip above the ground (which in turn is determined by the air breakdown limit at the earth). Reasonable values for charge per unit length, leader velocity, and distance of the leader above the earth are 10^{-3} C/m, 1×10^8 m/s, and 50 m. A solution of Maxwell's equations for this case yields a rate of change of 1.3×10^{12} V/m/s.

5. EMP Criteria. The EMP criteria are required for weapon system safety and reliability per AR-70-60. A nuclear burst produces radiation that ionizes surrounding material, e.g., weapon debris, air, soil. The resulting currents can create large electric and magnetic fields. EMP criteria are developed specifically for each system based upon the approach outlined in classified QSTAG 244 and with the information provided in classified DNA EMP handbook, DNA 2114H, Volume IV. A new MIL-STD-2169 has been written which has changed the requirements in QSTAG 244, however, this MIL-STD has not been released at this time due to classification restrictions.

A weapon system must meet the specified operational criteria (usually specified in terms of recovery time when in reference to component reliability) when exposed to a radiated EMP environment. The criteria are based on a high altitude nuclear detonation which causes large fields on the ground and in the atmosphere over a wide area. This is called high altitude burst EMP (HABEMP). The specific criteria is classified and can be found in Quadrupartite Standardization Agreement-244, Edition No. 3, Nuclear Survivability Criteria for Military Equipment (Confidential).

The EMP will couple into electro-explosive devices (EEDs) and electronic systems to a varying degree. Solid state components are most susceptible, particularly where they interface with cables which are oriented to permit efficient coupling of the EMP to the cables. Exposed apertures and antennas are prime candidates for efficient electromagnetic coupling, which can produce large amplitude voltage and current transients. These transients can cause upset of digital logic systems and damage to electronic components unless proper EMP protection is employed; e.g., protective circuits and devices, cable filters, proper grounding, electromagnetic shielding, and isolation. Digital electronic equipment is potentially vulnerable to EMP because of the low threshold for electronic upset and damage. Electronic component damage, logic loss, and transient malfunction are possible.

TABLE 7. Electromagnetic Fields from Nearby Lightning
(Cloud-to-Ground)

Magnetic Field Rate of Change @ 10 m:	3.2×10^9 A/m/s
Electric Field Rate of Change @ 10 m:	1.3×10^{12} V/m/s
Maximum Electric Field	3.0×10^6 V/m

III. MISSILE TESTING TECHNIQUES

A. Introduction

The problem of protecting missile systems against electromagnetic energies is complex. Even if the designer knows how to design an EM-hardened system, there are still compromises that have to be made because of weight, size, cost, and incompatibilities and other parts of the system. Thus, certain types of tests are designed to help determine the electromagnetic compatibility (EMC) of the system. The testing techniques and philosophy used by Test and Evaluation Directorate, MICOM, are described below and located in the area shown in Figure 2, Electromagnetic Effects (EME) test area.

B. MICOM EMC Evaluation Program

The EMC evaluation program for missile systems is depicted in the block diagram Figure 3. Each test is described in this section as to how, in general theory, it is performed; however, for a specific system, depending upon its complexity, the tests are tailored to that system. As a result, each system usually will have unique test parameters.

1. Subsystems Level Tests. These tests are considered in early development tests on components or subsystems, or both, before a complete assembly can be made into a final system. Those components that fail to meet the requirements can be modified and then retested. With this procedure there is a high probability that when assembled, the overall system EM requirements will be met.

a. ESD Personnel Level

(1) Test Requirements. The test requirement for explosive devices (EEDs) or squibs, individually or assembled in ignitors, etc. shall not be adversely affected when subjected to the environment described in Table 5.

(2) Facility Available. The electrostatic (ES) generator, shown in Figure 4, is an Ion Physics Corporation Model 0-30 kv DC.

(3) Test Philosophy. Because this is a go-no-go, or one-shot, test, it must be done on a sampling basis, using statistical test method. That method used is the Bruceton test. There is a military specification that can be used as a guide in designing this ESD test: MIL-STD-331. In general, it takes from 0 to 50 EEDs to perform this statistical test. The charge is discharged through all possible modes of the EED, such as pin-to-case, pin-to-pin, etc.

Since, in general, human charge will reach 25 kv, any functioning at lower voltage indicates a definite personnel hazard.

b. EMI

(1) Test Requirements. The EMI test requirements in this section are based on MIL-STD-461B, MIL-STD-462 Notice 3, and MIL-STD-463.

(2) Facility Available. The facility is housed in a 13-foot by 30-foot screen room, divided into a 13-foot by 13-foot test equipment control room & a 13-foot by 16-foot test area room shown in Figures 5 and 6. Equipment is available to support all requirements of MIL-STD-461B. Some of the major items available to provide rapid quantitative testing of missile component systems and subsystems include a spectrum analyzer, frequency synthesizers, HP9825 computer-controller (Figure 5) and other equipment for computer controlled testing.

(3) Test Philosophy. The components and subsystems are tested to the EMI requirements, thus adding to the assurance that when assembled into the system there are no other EMC problems. There are three basic types of effects:

- Effects between subsystems
- Effects of subsystems upon external systems
- Effects of external systems upon the subsystems

These effects are divided into the following test methods:

- Radiated interference
- Conducted interference
- Radiated susceptibility
- Conducted susceptibility

2. System Level Tests. These tests should be conducted as early as possible in development; i.e., when enough of a system becomes available for a meaningful test. These tests are conducted in order to determine problem areas and develop fixes that can be implemented into the final design.

a. EMP

(1) Test Requirements. The objective of this test is to obtain the data necessary to support an EMP hardness evaluation of the system and to determine if the system meets the specified performance criteria. When appropriate, the test may also be planned to obtain data on the impact of hardness improvements.

(2) Equipment/Facility Available. A Transportable Electromagnetic Pulse Simulator (TEMPS) used by Defense Nuclear Agency (DNA) on previous EMP tests was obtained by MICOM from DNA on a loan agreement. The TEMPS is currently operated with a 100 KV repetitive pulse generator which produces a peak field level of approximately 1000 volts per meter at a distance of 50 meters (Figure 7). The six-million-volt threat level pulser may be available at MICOM in the future. In the interim, MICOM has been using the current TEMPS for low level coupling tests and when necessary, taking systems to threat level simulators at other locations. This approach has been efficient because the costs of tests in the MICOM TEMPS simulator are low compared to

threat level simulators. The results of the low-level tests can then be used to reduce the number of measurements to be made of EMP-induced currents and voltages on the threat level tests. The low-level tests may also be useful to identify where improvements in protection should be made prior to the threat level tests. For systems or subsystems which are fairly simple electromagnetically and which are designed and built to have a very large EMP safety margin, a low level test may be sufficient for determination of EMP hardness.

(3) Test Philosophy. When the priority of the system to be tested is high enough to make the resources available, a high confidence EMP hardness assessment can be obtained by thorough pre-test analyses and test planning followed by logical exploratory type test and technically sound post-test evaluations of the data and the system functional responses. For systems that are even minimally complex in terms of potential electromagnetic coupling paths, one or more threat-level tests are required. These threat-level tests may involve single cable current injection, simultaneous multiple cable current injection, subsystem illumination, or full system illumination. The optimum approach for EMP testing is different for each system and should be developed by EMP test and evaluation specialists with the assistance of specialists that understand the normal functional design and performance of the system. A typical EMP Test Instrumentation is shown in Figure 8.

When the resources are not available for a high confidence EMP hardness assessment, the specific approach adopted should be structured to yield the maximum amount of useful information both about the hardness of the system and the uncertainty in the overall assessment.

b. MIL-E-6051D (System EMC Tests). This test requirement is for systems electromagnetic compatibility, including control of the system EMR environment, lightning, electrostatic, and EMP; also for complete systems with all associated subsystems and equipment.

(1) ESD

(a) Test Requirements. The test requirements for the EEDs, or squibs, installed in the system shall not be adversely affected, i.e., they shall not be fired or the impedance changed due to the environment. The electronics, transistors, micro-processors, diodes, etc., shall not permanently damage due to the environments. The environmental data are listed in Table 4.

(b) Equipment/Facility Available. The electrostatic generator, shown in Figure 9, is an Ion Physics Model 0 - 300 kv DC which consists of an oil-immersed power supply utilizing the Cockroft-Walton voltage-multiplier technique, a 1000-pf high-voltage cable with a 500-ohm series resistor, a 300-kv busing and toroid, and a control console.

(c) Test Philosophy. This test is done two ways, a go-no-go or one-shot and an instrumented test. The one shot test requires a large sample size and the larger the sample size the more confidence there is in the test. Ideally, the sample should be 40 to 50 samples, however, the minimum number of test samples used is ten. For the instrumented test, see Figure 10, the measurements are made of the transient currents induced in the

bridgewire of each EED caused by ESD to selected points. The measurements are made through the use of a fiber optic instrumentation link which allows both for high voltage isolation of the sending unit from ground and the prevention of non-tactical coupling modes which would result from use of signal cables. The sending unit is placed inside a void of weapon systems. The transient currents are sensed by wide bandwidth shielded current probes placed around each single conductor to the EED. The sensed signal from each current probe is linked to the fiber optic transmitter via a short length of double shielded coax cable. The measured transients are recorded by photographing the single sweep of a Tektronix 485 oscilloscope. To establish the safety margins for the EEDs the same technique described under lightning testing techniques paragraph III.B.2.b.(2)(c) is used. The primary objective of this test is to determine if a system, installed in a logistics shipping container or in the configuration for transport by the helicopter, can survive the environment. A typical test includes the following steps:

- Suspending the system from an insulated fixture and connecting it to high voltage probe or toroid.
- Charging the system to plus or minus 300,000 volts. This may not be reached because of Corona breakdown; attempts are made to reduce discharge to allow buildup.
- Discharging the system at selected points; usually three or more discharge points are selected.
- Replacing EEDs and repeating the three steps above 1. this is the one shot method. A minimum of ten test cycles is conducted, replacing all EEDs after each cycle; this allows for dispersion in EED characteristics.
- Lowering the voltage when EED detonation occurs for subsequent cycles until the failure threshold is obtained, if this is the one shot method.
- Visually and electrically checking all EEDs prior to and after each test cycle.
- Inspecting structural damage to the system and checking system electronics for operational integrity prior to start of test and after completion of test.

(2) Lightning

(a) Test Requirements. The test requirements are different for direct strikes and nearby strikes. In both cases, however, it is required to determine if EEDs which could create safety hazards will survive and not detonate. Any premature detonation of hazard related EEDs is considered a safety problem.

It is usually not required that the vehicle be operational after a direct strike (see paragraph II.B.4.a). For nearby strikes, however, it is required that the system survive and be able to perform its mission.

(b) Equipment/Facility Available. Laboratory testing of piece parts can be done using the MICOM equipment. The equipment typically involves high current or high voltage generators capable of stressing small parts to high levels.

System level direct strike testing is done in two parts. The first part involves the electromagnetic coupling from the lightning environment and is mainly related to $\frac{\partial I}{\partial t}$ (Figure 11). The second part involves the high current test which injects a great deal of energy (large action integral) into a system. Both the high $\frac{\partial I}{\partial t}$ test and the high current test can be done at the MICOM EMR facility.

The nearby lightning tests can also be done using the MICOM EMR facility.

A more detailed description of how these facilities are used is given in the next section on Test Philosophy.

(c) Test Philosophy. The lightning effects upon a weapon system may be thought of as coming from three separate parts of the waveform. The electromagnetic coupling effects come from the leading edge, or high $\frac{\partial I}{\partial t}$ (or high $\frac{\partial E}{\partial t}$) part of the waveform. The physical damage is usually caused by the high current part of the waveform, in which a lot of energy is injected into a weapon system. The burning and pitting associated with lightning strikes is usually associated with the continuing current, which provides most of the charge transfer, and is similar to an arc-welder.

It would be desirable to test for all of these effects in one complete test. This can be done, but this is not usually possible because of cost and schedule constraints. In order to perform the tests this way, several different types of generators would need to be brought to the test location and operated together with the proper synchronization.

While this type of testing can be done and is done at some non-Army installations located throughout the United States, the approach accomplished at this facility is to perform the tests separately. The continuing current testing is done on piece parts in a laboratory setting. The high $\frac{\partial I}{\partial t}$ is accomplished with a Marx generator source, and the high current tests are done with a parallel bank of capacitors charged to a relatively low voltage.

The way in which the EMR facility (low frequency chamber) and a Marx generator are used together is indicated in Figure 12. The approach here is to use the Marx to charge up the upper plate like a capacitor, and then discharge it into the test vehicle through a large diameter down electrode and an air spark gap. In this way, the rise time of the leading edge of the waveform is not limited by the Marx inductance. The trade off is that there are some undesirable resonances in the test current which have to do with the physical dimensions of the down electrode and the upper plate.

Figure 13 indicates the time domain current waveform and Figure 14 is its spectral content amplitude.

The high current test is done with a large bank of parallel capacitors charged to perhaps 100 kV. A typical current waveform and its Fourier amplitude spectrum is shown in Figures 15 and 16.

The nearby strike tests can be done by moving the weapon system slightly outside the EMR array and moving the down electrode to the edge, as shown in Figure 17. This is done so that weapon system cables which lie on the surface of the earth have a realistic ground plane. If the facility had no such ground plane, it would be possible to test the system internal to the array as was done for the direct strike case.

The current waveform and magnetic fields would be similar to that of the direct strike case of Figures 13 and 14. The electric field waveform and its derivative are shown in Figures 18 and 19.

A pretest study is done in order to identify the most probable strike points and those which are more susceptible to damage or likely to cause safety problems. Several test shots can be taken by injecting into several different points, or, for the nearby strike case, for several different orientations. Power-off and power-on conditions for the weapon system also need to be considered.

It is desirable to instrument internal test points so that safety margin can be identified as well as extrapolation made to ideal threat waveforms. A typical instrumentation system consists of voltage or current probes, a fiber optic data system, and computer controlled transient digitizers or oscilloscopes as shown in Figure 20. The digital format allows for relatively straightforward data manipulation.

Finally, it is usually the case that there is only one complete weapon system available for test. Because issues of safety are of concern, it is necessary to further quantify susceptibility margins by obtaining statistical data on many samples of the EEDs of interest.

This is accomplished by obtaining the induced responses on the EED's of interest during the system level test, and then testing statistically significant numbers of them in a laboratory setting by means of the so called Bruceton tests (6). The thresholds of the EEDs are then related to the weapon system level test responses to obtain a statistical statement of EED detonation.

Susceptibility or safety margins of EEDs are obtained by comparison of measured or extrapolated responses with data from sensitivity tests of the EEDs. The sensitivity tests often use Bruceton analyses to establish "no fire" levels at given confidence levels. Note that both differential mode current and common mode voltage sensitivities and responses are necessary to establish a system safety margin for each EED.

3. External EMR. This environment includes emitters outside the system, which could include radar from other systems, broadcast, enemy systems, etc. This EMR environment is simulated with broadband transmitters for EMRH and EMRO tests and are conducted in an open field-type facility (Figure 21), with several subsets of antennae covering the 100-KHz to 18-GHz range.

a. EMRH Test Requirements. The objective of this test is to determine if exposure to the EMR environment listed in Tables 1 and 2 could lead to any hazardous conditions or a degraded condition caused by premature detonation, or dudding, or any EED. Since all EEDs in a system usually do not cause a hazardous condition when prematurely detonated, or dudded, this is designated as a reliability problem; however, they are instrumented and tested just as the hazardous EEDs. For this report, all EEDs are labeled as an EMRH test.

The hazardous EEDs will meet a safety margin of 10 dB and 16.5 dB and the non-hazardous EEDs will meet a safety margin of 6 dB and 6.5 dB when exposed to the test levels of Table 1 and 2 respectively. These safety margins are derived as

$$\text{dB (Safety Margin)} = 20 \log \frac{\text{Maximum No Fire Current}}{\text{Induced EMR Current (or minimum detectable current)}}$$

b. EMRO Test Requirements. The objective of this test is to determine if prelaunch and inflight systems can operate, without degradation of performance, in the environment specified in Tables 3 and 4. In general, all degradation of performance of controls or electronic components does not cause a reliability problem. The degradation of performance is based on either a temporary or a permanent deterioration, or both, or failure caused by EMRO of any component, circuit, or material which prevents the systems from meeting their intended operation, performance, and, possible safety requirements during the test environment. The fail-pass performance is determined by the criticality of a specific component, circuit, etc., to the system performance. This is usually determined jointly by the designated testers and Project Manager's Office (PMO); the corrective action in test is determined as required.

c. Equipment/Facilities Available for EMRH and EMRO. The EMR testing methods used are based upon the Test and Evaluation Directorate, US Army Research and Engineering Center Test Facility. This facility has been designed specifically for testing missile systems in the development cycle. It was designed to give fast test results so that a system design can be changed early in development if there are EM-associated problems. The flexibility of this facility allows interactions with a more meaningful system evaluation. Test data are available in real time to provide for a quick-look evaluation. An aerial view of EM environmental capability of the Test and Evaluation Directorate facility is shown in Figure 21.

(1) Transmitters. The transmitters with associated antennas are presented in Table 8. They are available for testing in the 100-KHz to 18-GHz frequency range. All of the transmitters are capable of CW, AM, and PM operation (Figure 22) (100 KHz to 10 GHz).

(2) Ancillary Transmitter Equipment. The following equipment is available to support transmitter operations:

- Frequency synthesizer, Watkins-Johnson Model 1250
- Automatic Synthesizer, Hewlett-Packard Model HP3330B
- Synthesized Signal Generator, Hewlett-Packard Model 8660C
- Signal generator, SINGER Model 6201
- Multiple-band signal source, Hewlett-Packard Model 8340
- Signal generator, Hewlett-Packard Model 8690B with a full complement of plug-ins.
- Signal generator, Singer Model 1000
- Frequency counter, Hewlett-Packard 542M, with prescaler and 1000:1 divider.
- Frequency counter, Hewlett-Packard Model 5340A
- Power meters, Hewlett-Packard Models 431A, 432B, 432C, and 435
- Miscellaneous - dummy load isolators, directional couplers attenuators, coaxial switches, oscilloscopes, detectors, spectrum analyzers, network analyzers, and X-Y plotters.

(3) Antennas. A detailed description of the transmitting antennas used in testing at this facility is presented in Table 8 and in Figures 23, 24, and 25.

(4) Field Measuring Equipment. The following field measuring equipment is available to measure and insure field uniformity:

- Antenna set, B dot probe (H field)
- Antenna set, National Bureau of Standards (NBS)
- Antenna set, non-interactive probes
- Antenna set, 20 Hz to 1 GHz
- Antenna set, standard gain dipoles

TABLE 8. Transmitter Systems

FREQUENCY MHz	TRANSMITTER SYSTEMS		ANTENNAS
0.1 - 30	RF Communications, Inc. Model #RF-745, 10 KW	Instruments for Industry Model 404A, 200 watts .2 - 220 MHz	KAMAN Sciences RF Chamber
	Electronic Navigation Industries, Inc. Model 240L, .02-10 MHz, 200 watts		Bounded Wave Chamber-150 ft x 150 ft x 30 ft
30 - 350	RF Communications, Inc. Model #RF-712, 5 KW	Microwave Power Devices Model PWAL 2240-13 225 - 400 MHz, 1.0 KW	Nurad Log Periodic, Gain = 6 - 10db
			Standard Gain Horns Gain = 16 - 18 dB 100 to 350 MHz
350 - 500	Microdot Model 445 50 watts	Microwave Power Devices Model 4565-22/3320 450 - 650 MHz, 200 watts	Standard Gain Horns Gain = 18 dB
	Microwave Power Devices Model PWA 3545-22 350 - 450 MHz, 200 watts	Microwave Power Devices Model PWAL 2240-13 400 - 500 MHz, 1.0 KW	or Ridged Horns, Gain = 6 - 12 dB
	Microwave Power Devices Model PWAL 204-13 225 - 400 MHz, 1.0 KW		
500 - 1000	Microdot Model 445 50 watts	Watkins-Johnson System (Litton TWT L-2055) 1.5 KW Nominal	
1000-2,500	Hughes TWT, 1277H 20 watts	Watkins-Johnson System (Litton TWT L-2055) 1.5 KW Nominal	Standard Gain Horn, Gain = 16 dB
2,500-4000	Hughes TWT, 1277H 20 watts	Watkins-Johnson System (Teledyne MGC TWT 5483-W) 1.5 KW Nominal	
4000 - 8000	Watkins-Johnson System, 1.5 KW Nominal	(Teledyne MEC TW M5819-W)	
8000-10000	Hughes TWT, 1277H 20 watts	Watkins-Johnson System Teledyne MEC TWT M5803 1.5 KW Nominal	
10000-18000	Hughes TWT's Model 1277H, 20 watts		

SIGNAL GENERATORS

Marconi Instruments Model 2022, 10 kHz - 1000MHz
 Hewlett-Packard Model 3330B, Auto Syn, 0.1 Hz - 13 MHz
 Hewlett-Packard Model 8640B, 0.5 MHz - 1.1 GHz
 Singer Model 6201, 50 KHz - 500 MHz
 Hewlett-Packard Model 8660C, 1 MHz - 2.5 GHz
 Hewlett-Packard Model 8690B, 4 MHz - 28 GHz
 Watkins-Johnson Synthesizer Model 1WJ-1250, 100 MHz - 18 GHz
 Hewlett-Packard Model 8340, 10 MHz to 26.5 GHz
 Singer Model 1000, 0.65 to 8 MHz

- Standard gain horns, 1 to 18 GHz
- Power Meters, Hewlett-Packard Models 431C, 432A, 432B, and 435.
- Portable Broadband Radiation Monitoring system, Narda Model 8616 w/probes
- Spectrum Analyzers, Hewlett-Packard Models, 8581A, 8556A, 8553B, 8555A, and 8566A.
- Antenna Calibration
 - Narda, TEM Transmission cell, Model 8801, DC to 500 MHz.
 - Narda, TEM Transmission cell, Model 8802, DC to 250 MHz.
 - Electronic Navigation Industries, Inc., (ENII) Model 500L, Power amplifier, 2-500 MHz, 300 milliwatts
 - ENII, Model 503L, Power amplifier, 2-510 MHz, 3 watts
 - ENII, Model 320L, Power amplifier, 250 KHz to 110 MHz, 40 watts
 - ENII, Model 525LA, Power amplifier, 1-500 MHz, 25 watts
 - RF Power Labs, Inc., Model M1026, Wideband amp, 10 Hz - 100 MHz, 2 watts
 - Amplifier Research Model 2000 LM 25, 10 kHz - 220 MHz, 2000 watts
 - Amplifier Research Model 1000 HAM 6, 220-400 MHz, 1250 watts

All antennas are calibrated against the NBS antenna set.

(5) Instrumentation Equipment. The basic technique used for data retrieval from missile systems under test is an infrared (IR) data link. This consists of onboard signal conditioning equipment and IR transmitter which transforms the electrical signals into a modulated IR signal. This signal is coupled via non-conductive fiber optics to receiver and wired into the recording station (Figure 26). The recording system is available for receiving and recording data from systems under test. Housed in a completely RF-shielded enclosure, it has a full complement of equipment, including discriminators, oscilloscopes, direct-write oscillograph recorders, tape recorders, and various general test equipment, including power supplies, signal generators, frequency counters, etc. This method of instrumentation virtually eliminates the problem of affecting the antenna characteristics of the system under test and the EMI in the instrumentation link.

(6) Test Fixture (Figure 27). A Scientific-Atlanta positioner system is available for supporting and positioning the test specimens. The system consists of an azimuth positioner, model tower, and a programmable digital controller. The system is capable of supporting a vertical load of 20,000 pounds.

(7) Computer-Controller. The operation of the facility is centered around a HP1000 Computer (Figure 28), which performs the following control functions and data formatting:

- Controller - The HP1000 computer is used to control items under tests (IUT), monitor the field strength measurements and provide other controller functions as required.

- Positioner Control - The controller is used to position the test specimen automatically by controlling a Scientific-Atlanta azimuth positioner.

- Data Analysis and Display - The data from the test specimen are interfaced with the HP1000 Computer for real time record and analysis. All pertinent test conditions and parameters, such as frequency polarizations, etc., along with monitored data from systems under test, are automatically recorded. In addition, a graphic terminal with hard-copy capability is available for providing data plots for quick-look analysis and reports.

(8) Instrumentation (Figure 29).

(a) System Package. The onboard instrumentation system consists of standard Inter-range Instrumentation Group (IRIG) sub-carrier oscillators, a light-emitting diode (LED) with amplifier, and a fiber optics link to transmit the IR signal from the missile to the receiver. The test signals are obtained from the instrumented EED for the EMRH test, or from the control circuits for the EMRO test. The EED is instrumented with a miniature thermocouple mounted within 0.001 to 0.003 inch of the bridgewire to sense temperature rise or a vacuum thermocouple impedance matched to the replaced EED. The system is calibrated by applying a direct current through the bridgewire or the thermocouple and recording system response. The signals for the EMRO test are usually monitored at the system telemetry connector. The signals (EMRH and EMRO) are conditioned and used to frequency modulate the subcarrier oscillator whose outputs are mixed, amplified, and used to modulate the LED. The IR signal is then transmitted to the receiver via fiber optics. Note: vacuum thermocouples are used when the EED is a very sensitive EED and extremely difficult to instrument by the conventional method.

(b) Receiving System. The IR signal is converted to an electrical signal at the receiver which is housed in a shielded inclosure and carried to the receiving station via coaxial cable and shielded by conduit. The signals are then separated by IRIG discriminators, recorded, and monitored through the use of the computer. The receiving, or ground, station is shown in Figure 28.

d. EMRH Test Philosophy.

(1) Objective. The effects on missile systems caused by the EMR environment designated in Tables 1 and 2 are investigated to determine if exposure to this environment could lead to any hazardous or degradation conditions caused by premature detonation, or dudding, of any EED.

(2) Method. A basic requirement for conducting and instrumenting missile systems for EMRH tests is to minimize disturbance to the EM field, EED circuits, and the overall physical size of the system. (For example, no hardwire connections, no change in EED circuit impedances is allowed, and the instrumentation package should be mounted inside the missile airframe.) To minimize these effects, the following techniques are used:

- EEDs - Each live EED component in the system is replaced with a impedance matched vacuum thermocouple or with an EED that has all explosives removed, the bridgewire exposed, and a miniature thermocouple mounted within 0.001 to 0.003 inch from the bridgewire to sense the temperature rise when exposed to EMR. Each batch of EEDs is tested by the vendor to establish the maximum no-fire current (MNFC). This MNFC is used as the maximum calibrated level for the vacuum thermocouple or the instrumented EED. The vacuum thermocouple or the instrumented EEDs are installed in system in the exact location to simulate the tactical system. Outputs from the thermocouple are routed to the instrumentation package.

- Instrumentation Package - The instrumentation package or the telemetry (TM) system is usually located in warhead or rocket motor voids after removal of the explosive mixtures (Figure 29). A block diagram of a typical instrumentation system is shown in Figure 26. A TM package contains standard voltage controlled oscillators (VCO) with associated circuitry, a LED with an amplifier-driver, and necessary batteries to power the TM system. The TM system is packaged in a shielded container and installed in the warhead or motor case sections with all signals and power inputs brought in through low-pass filters. The multiplexed output of the LED is transmitted from the TM system via fiber optics.

- Fiber Optics Link - The LED output is coupled to the fiber optics which is normally brought out through a natural aperture in the missile airframe. This fiber optic is coupled into the IR receiver.

- Testing Configurations - The testing configuration includes the stockpile-to target sequence, such as personnel handling, shipping, storage, mounted on launcher (if applicable), and in some incidents after launch (in-flight), if premature ignition of an EED in this mode can cause a hazardous condition. The configurations include irradiation at various aspect angles, including front, side, and rear at specified frequencies, polarizations, and field intensities. The system may also be rotated 0° to 360° in azimuth to obtain a response pattern.

- Evaluation Criteria - During each test cycle, the instrumentation system provides data indicating the bridgewire current induced into each EED. If the test field strength is lower than required, then the bridgewire current is extrapolated to the required field strength level since it is directly related to the field strength. These levels are compared to the maximum no-fire direct current for each EED. The hazardous EEDs must exhibit a minimum safety margin of 10 dB for each test configuration.

- Fields Calibration - Reference (5) describes the methods of calibrating the B dot probe and controlling the EM test environment from 30 MHz to 350 MHz. Other B dot probes are calibrated and used in the 0.1- to 350-MHz frequency range. From 350 MHz to 10 GHz standard gain horns are used for transmission, and the HP1000 Computer is used to calculate the fields. For the 350-MHz to 18-GHz range, the fields are normally calculated using antenna gain curves and power delivered to the antenna.

- Statistical Techniques - Statistical technique is used to reduce the minimum detectible current (MDC). This MDC level is used by the HP 1000 Computer to determine whether a given data point is RF induced or not. The technique used has reduced the MDC to at least 10 times below the previous achievable values.

e. EMRO Test Philosophy.

(1) Objective. The effects on missile systems caused by the EMRO environment designated in Tables 3 and 4 are investigated to determine whether they could lead to a reliability problem by degrading the performance of the electronics. The degradation could cause burnout, either permanent or momentary upset, or both, which could lead to numerous problems, such as failure to launch or engage a target. These effects could be caused by either friendly or enemy EM sources.

(2) Method. In general the method of testing is the same for both EMRO and EMRH. In EMRO testing, critical electronic circuits are instrumented instead of the EEDs. The effects of various modulation on the carrier are critical in EMRO testing. The circuits monitored are usually the same as those monitored in actual flight by the telemetry (TM) system. The EMRO instrumentation package is normally interfaced with the critical circuits at the TM connector. If all the desired circuits are not available at the TM connector, then the system has to be modified to provide these signals. This modification is usually done by the system contractor. The same precautions taken in EMRH apply to EMRO; i.e., no external hardware connections, minimum change in monitored circuit impedance, and instrumentation package contained inside the missile airframe. Since these tests are operational, the electronics are energized in prelaunch and simulated flight modes. These modes are repeated for each test cycle, thus an ancillary system of powering electronics and sometimes cooling the detector has to be provided within the airframe or through external quick disconnects, etc.

- Monitored Test Points - By monitoring a number of missile functions and correlating this with test parameters, it is possible to determine the levels of EMR which will cause a very small influence (thresholds), as well as the level which will cause a catastrophic failure in the system. The missile system is usually considered to be susceptible if the guidance system breaks track on the target, or if degradation occurs which would reduce the effectiveness of the missile. The tests can be designed to obtain the necessary input data to support computer simulation for determining degrees of degradation in the guidance system.

● Instrumentation Package - As is the case of EMRH, the instrumentation package is located in a warhead or motor case void (Figure 29). A typical block diagram is shown in Figure 26. The TM package contains the required number of VCOs, associated circuitry, and a LED with an amplifier-driver. Each variable quantity of the monitored test points is assigned to a different VCO band. The incoming signals from the electronic circuits are conditioned at the input to the VCO to accommodate the higher voltages and to insure high input impedances to prevent loading or degradation to the circuits. The instrumentation package requires a shielded container with the input signals, lower leads, etc., brought in through low-pass filters. The output signals from the VCOs are combined, and the composite signal is applied to the fiber optic amplifier driver system and transmitted from the TM package via fiber optics. The instrumentation package operates from a 28-volt battery supply.

● Fiber Optics Link - The fiber optics link used in EMRO testing is the same as EMRH testing and as was previously described.

● Testing Configurations - The two basic modes of operation include prelaunch and simulated flight. The prelaunch mode test requires the launch equipment and personnel normally involved in launch operations. Simulated in-flight is accomplished by mounting the missile on the positioner. The system under test is usually irradiated head-on, side, and aft to determine frequency and modulation sensitivity and at varying aspects and roll angles after critical frequencies are determined. This is accomplished by energizing the transmitter, computer controller, data link electronics, etc., and energizing and stabilizing the missile electronics for the in-flight mode. The on-board TM package is turned on, the positioner is operated, tune and power-up the test transmitter, record test results, and the HP 1000 Computer documents test parameters.

● Evaluation Criteria - Data from each test cycle will determine if the field strength selected degraded the system. A predetermined percentage increase in monitored signals caused by the induced interference is usually established as the threshold of unacceptable effect. An in-depth analysis can be accomplished by a computer simulation of the system controls.

● Field Calibration Control - The calibration and control of field levels is accomplished as described in the EMRH test methods.

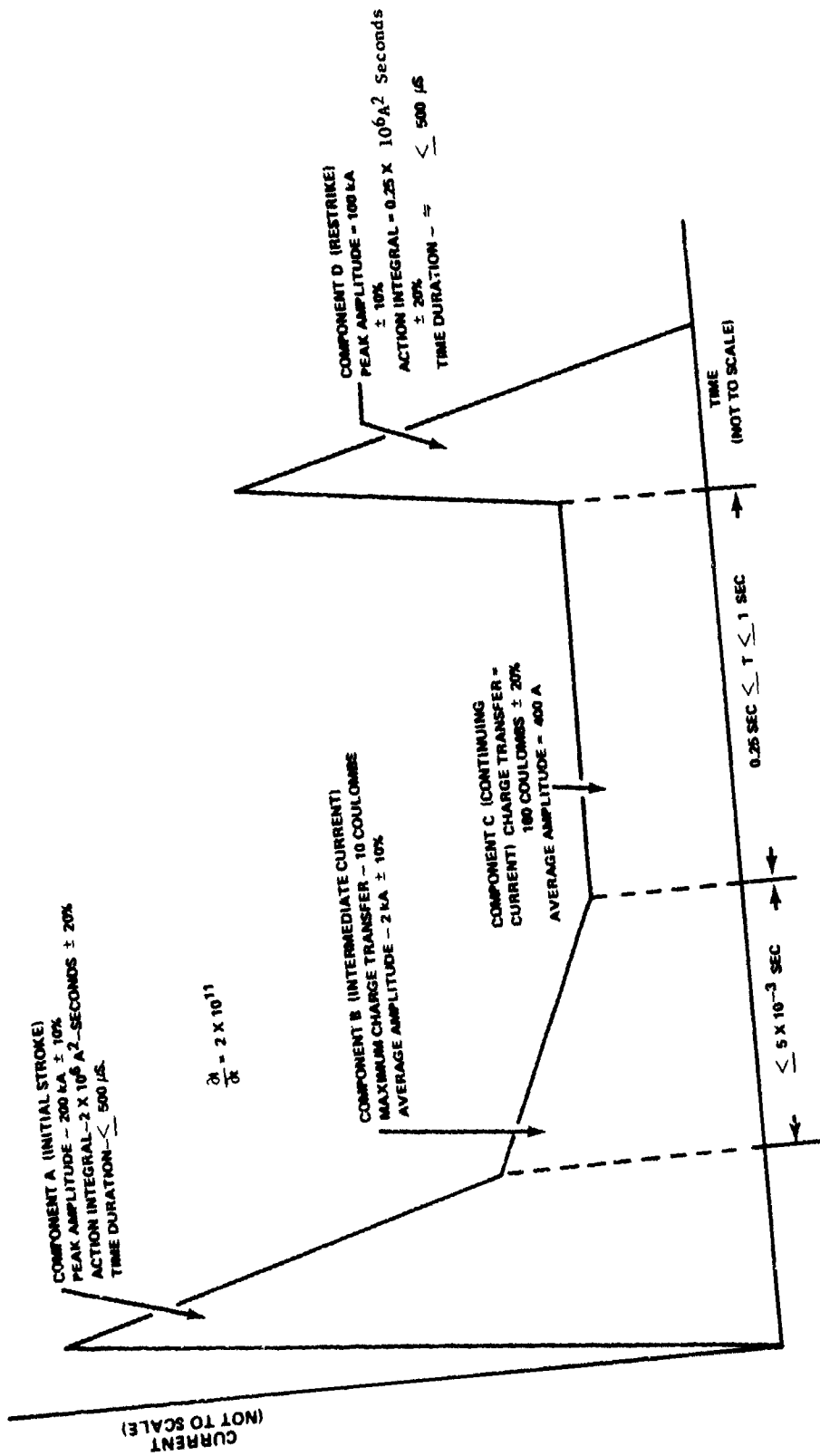
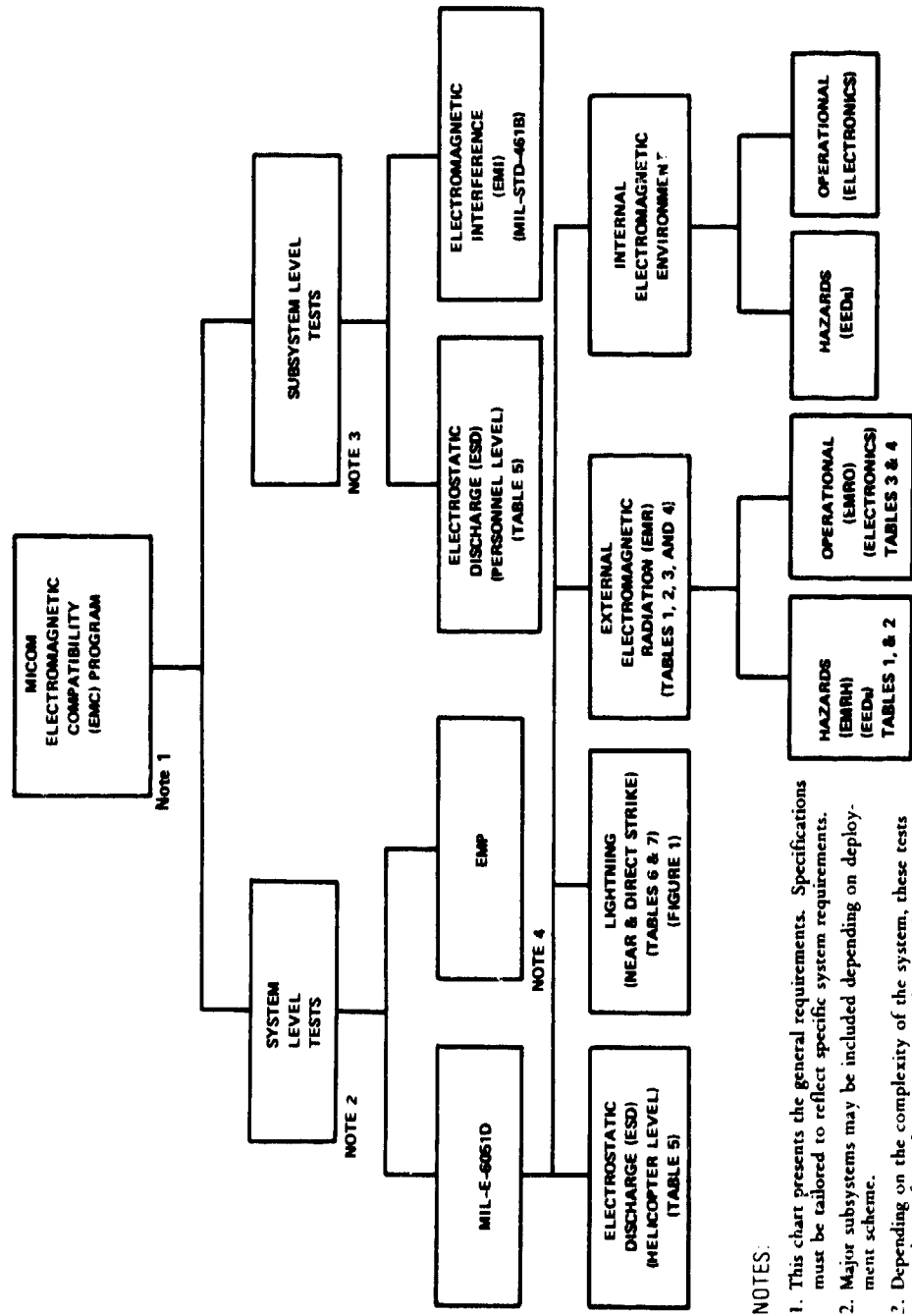

Figure 1. Direct strike idealized current test waveform.



Figure 2. EME test area.



NOTES:

1. This chart presents the general requirements. Specifications must be tailored to reflect specific system requirements.
2. Major subsystems may be included depending on deployment scheme.
3. Depending on the complexity of the system, these tests may be performed at system or subsystem level.
4. Depending on the complexity of the system, these tests may be a combination of direct drive and/or radiated on subsystem and system level.

Figure 3. EMC evaluation program.

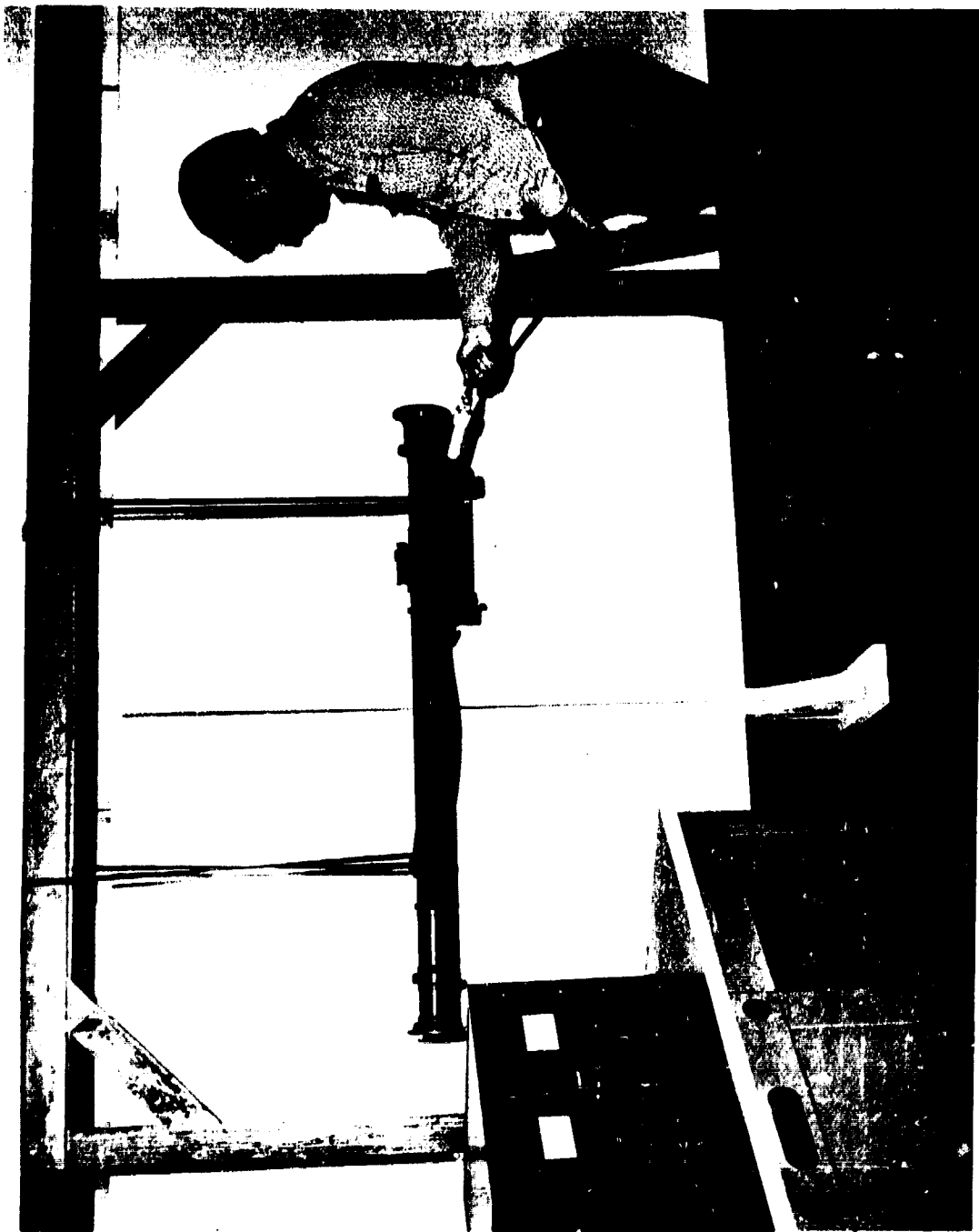

Figure 4. Electrostatic discharge (ESD) generator (0-30 kV dc).



Figure 5. EMI test instrumentation room.

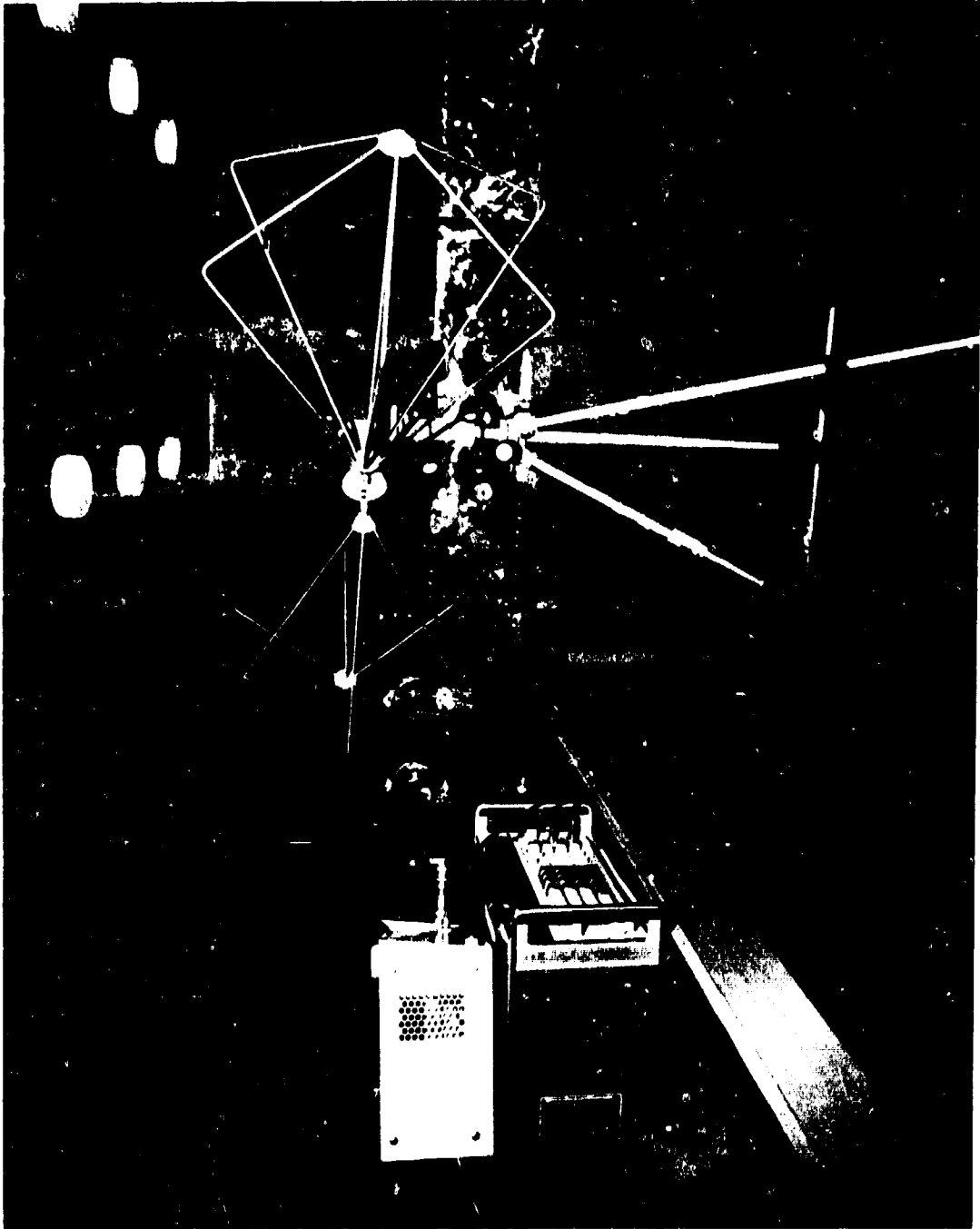

Figure 6. EMI test area room.

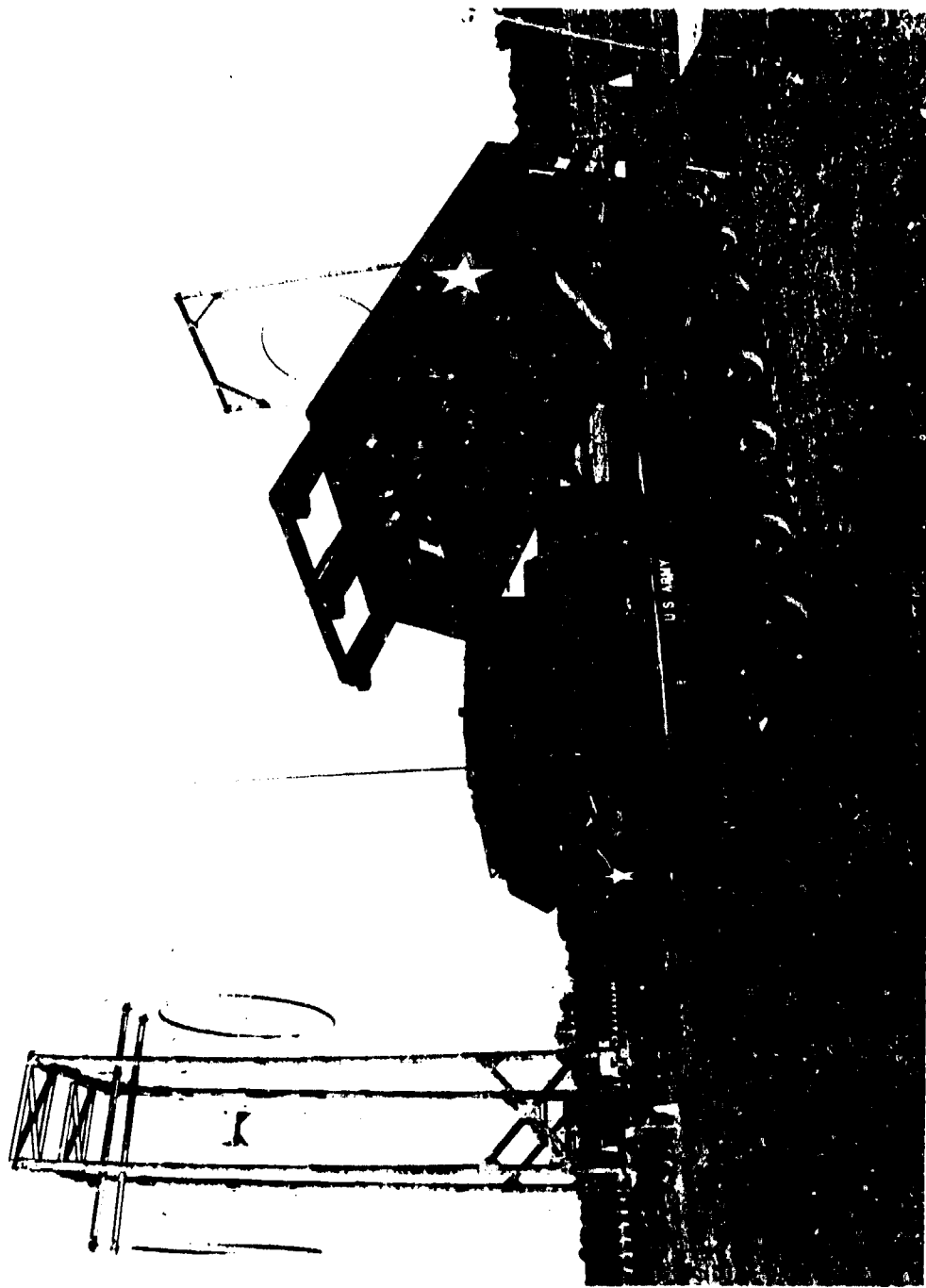

Figure 7. EMP test facility.

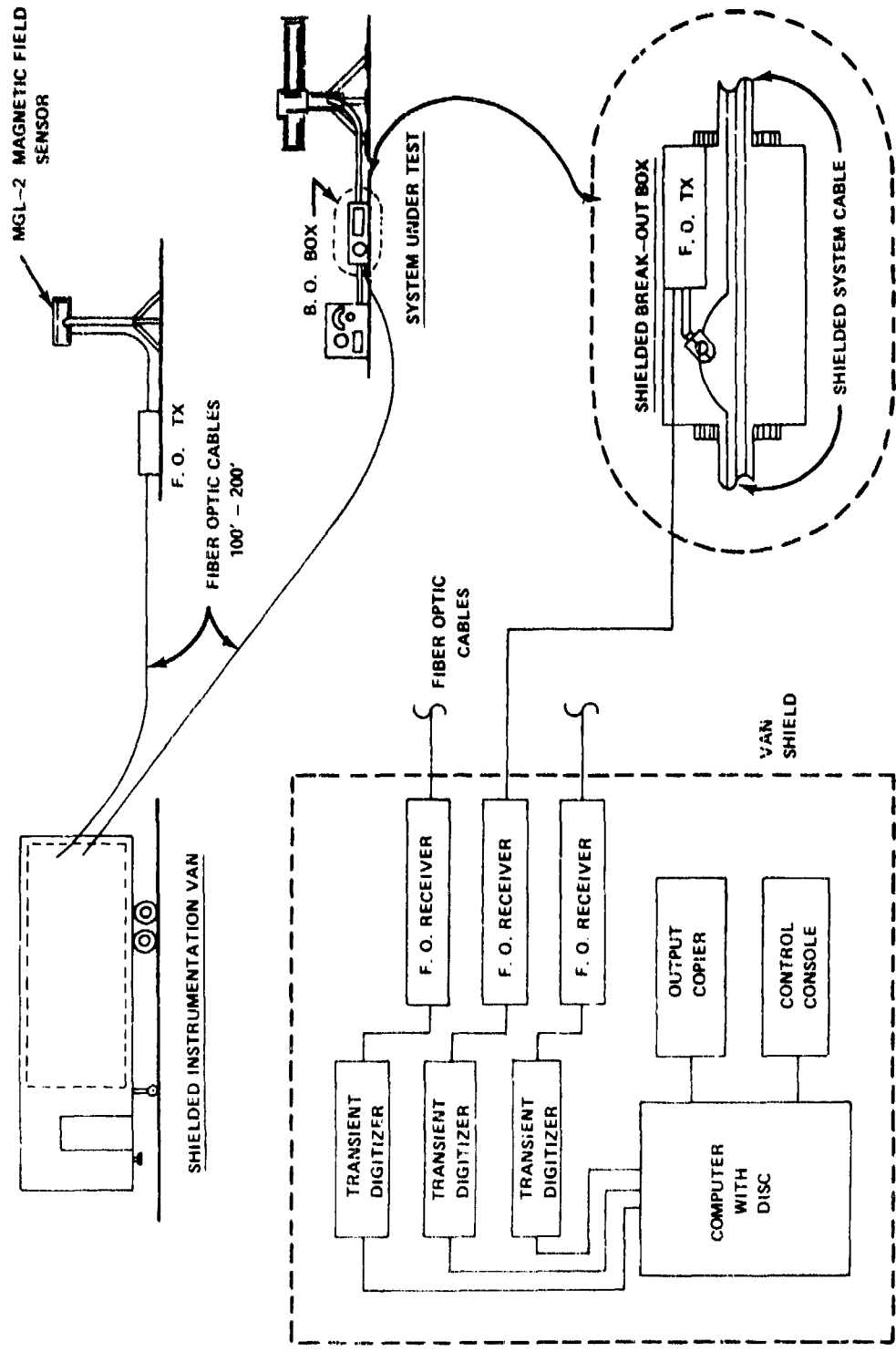
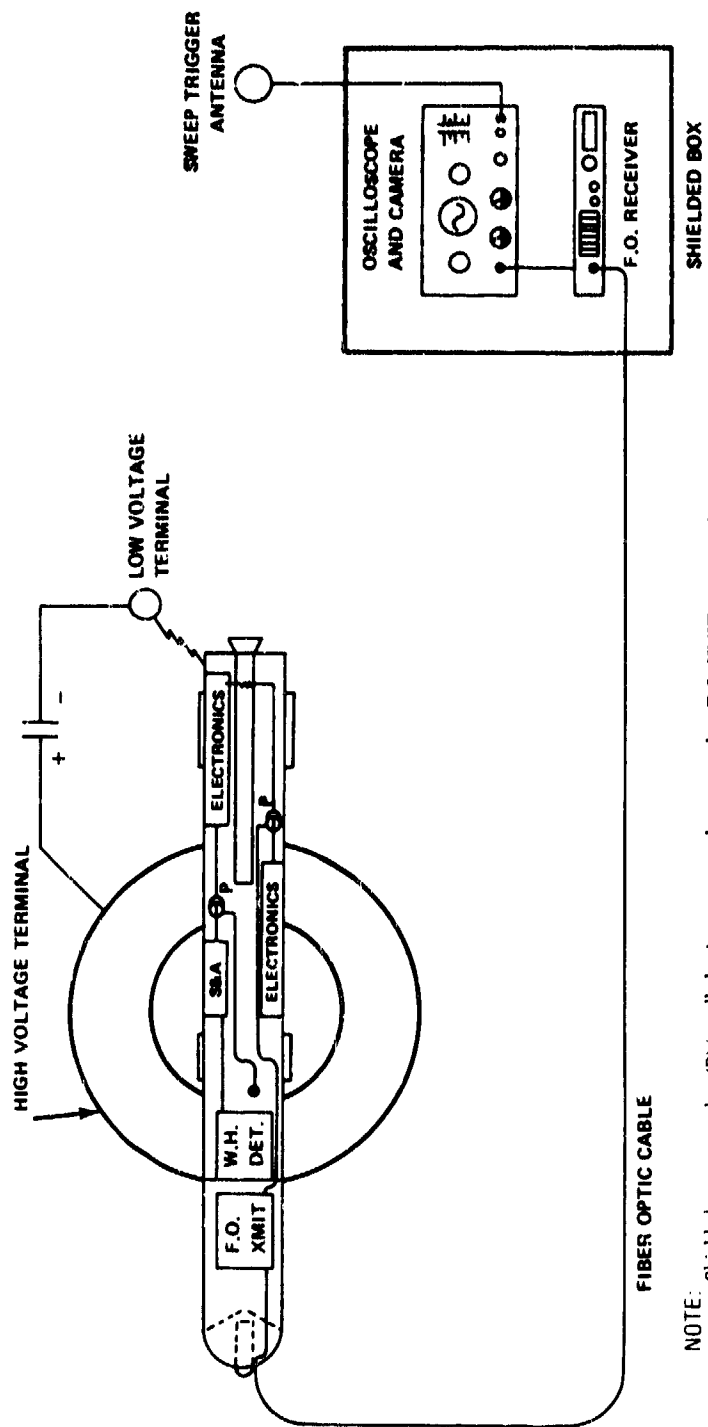

Figure 8. Typical EMP test instrumentation.



Figure 9. ESD generator (0-300 kV dc).



NOTE: Shielded current probes (P) installed prior to test and connected to F.O. XMIT. one at a time for measurements of ESD induced currents in selected electronics cables.

Figure 10. Instrumented ESD test.

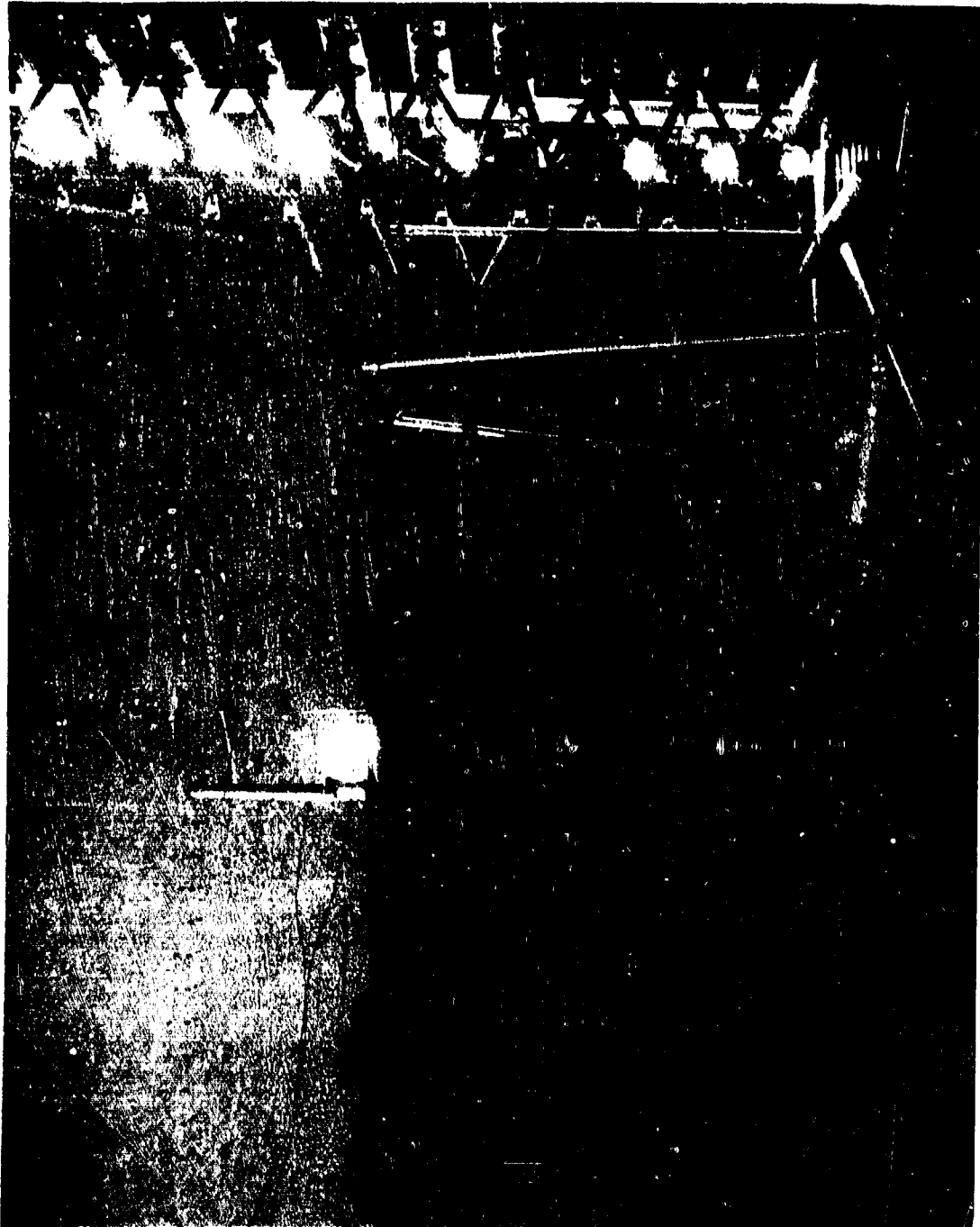

Figure 11. Direct lightning strike ($\frac{\partial I}{\partial t}$).

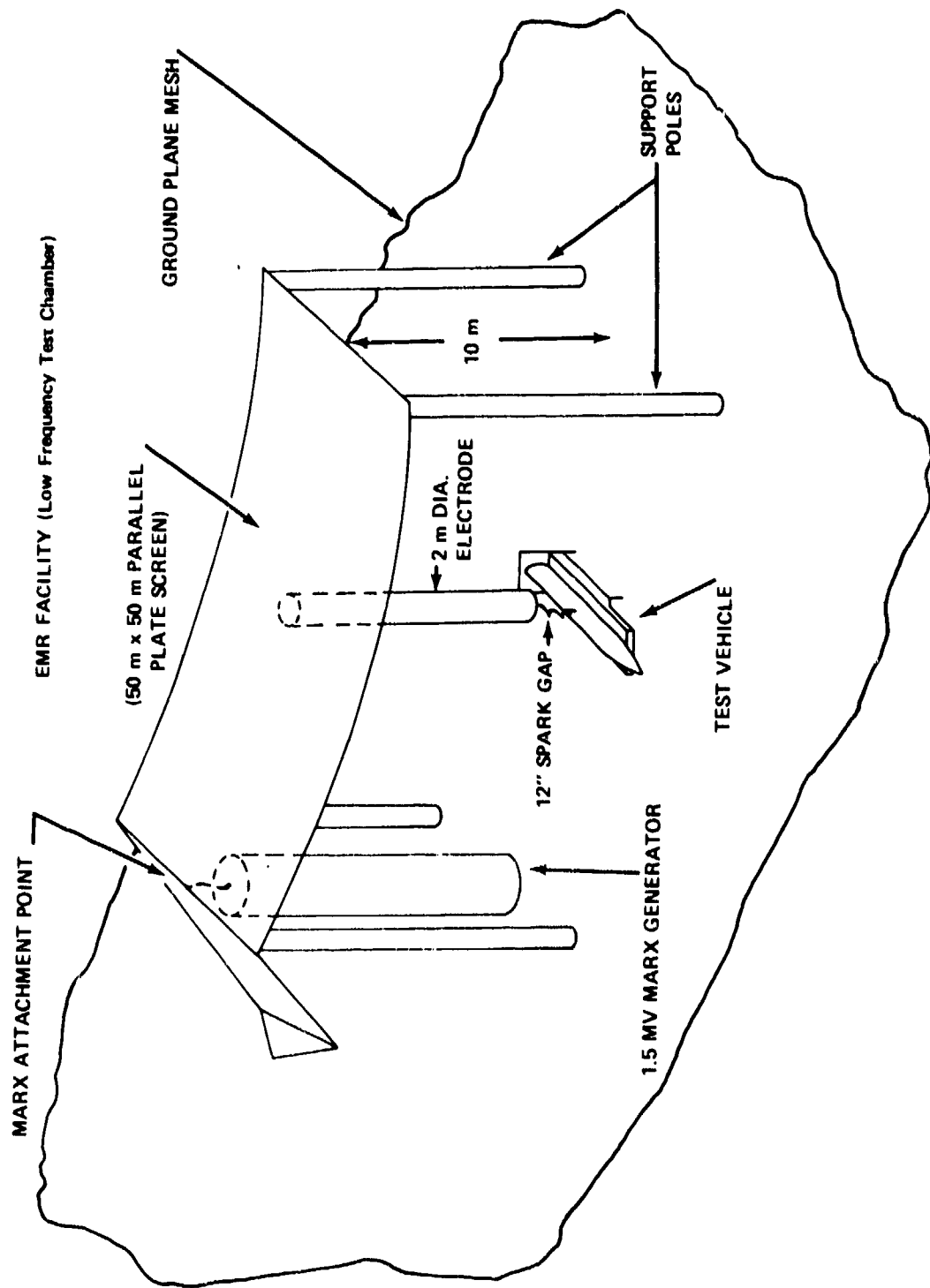

Figure 12. Direct strike test configuration.

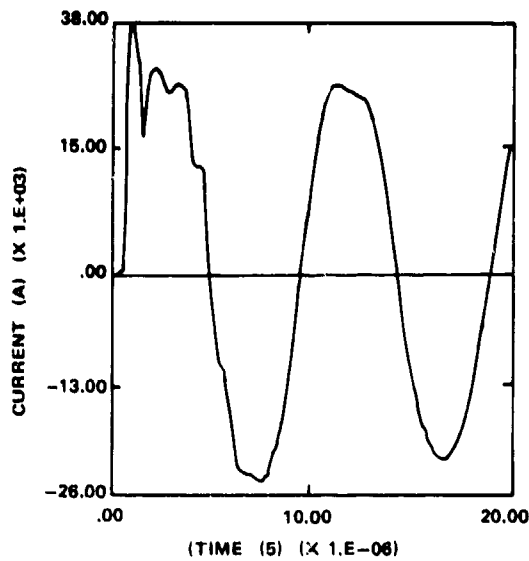

Figure 13. Direct strike current waveforms.

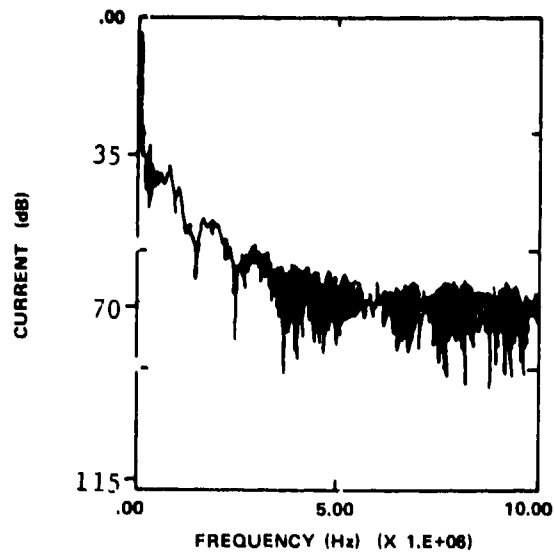

Figure 14. Frequency spectrum of measured direct strike current waveform.

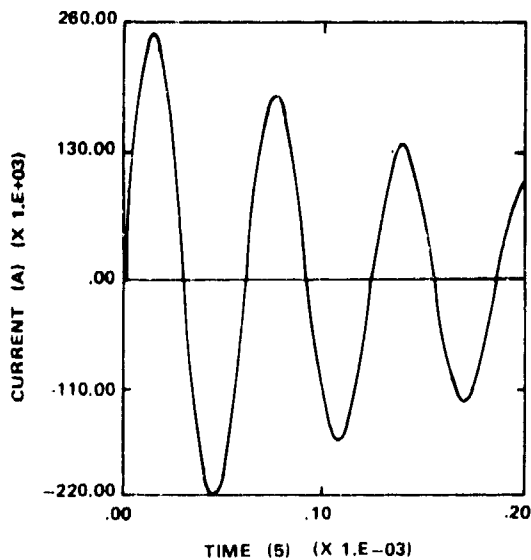

Figure 15. Injection current waveform for peak current, direct strike tests.

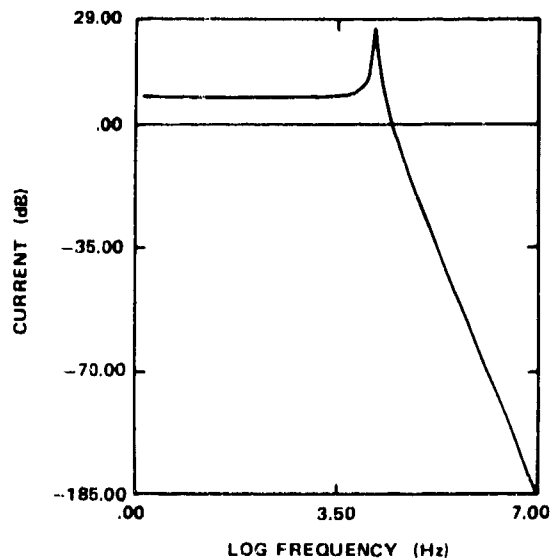

Figure 16. Frequency spectrum of high current, low frequency, direct strike waveform.

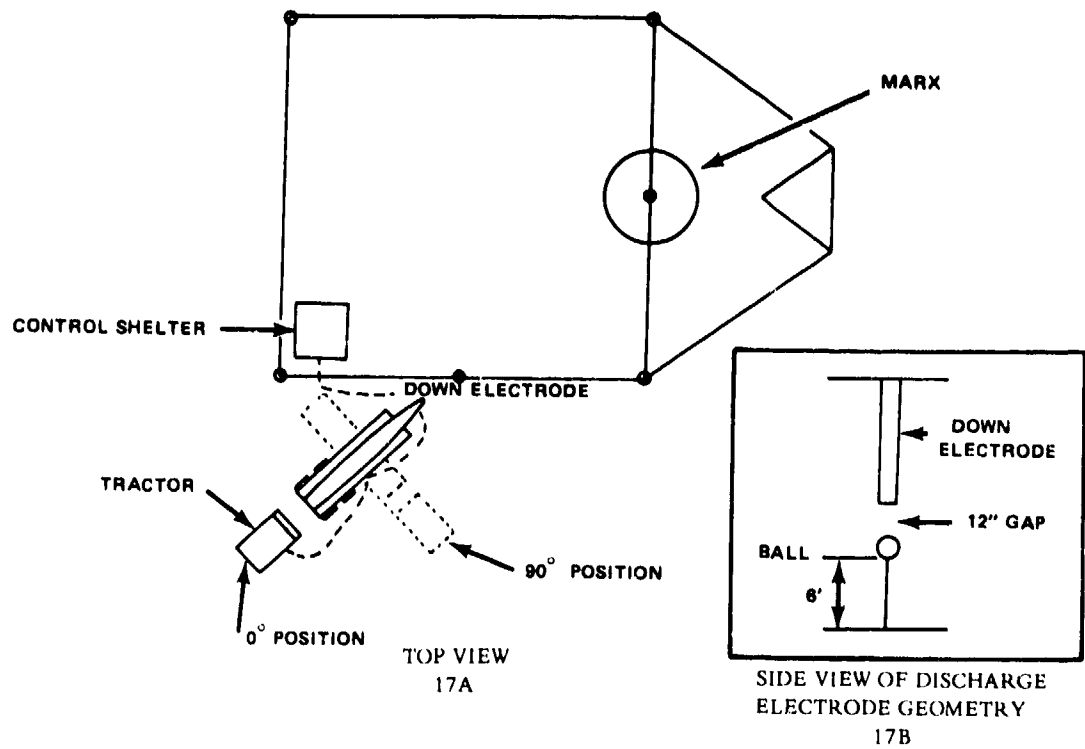

Figure 17. Plan views - nearby strike configuration and electrode strike.

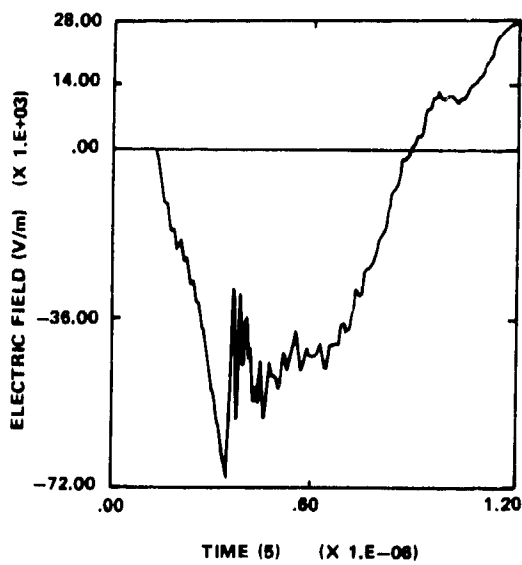

Figure 18. Electric field measured at 10 meters (from oscilloscope trace).

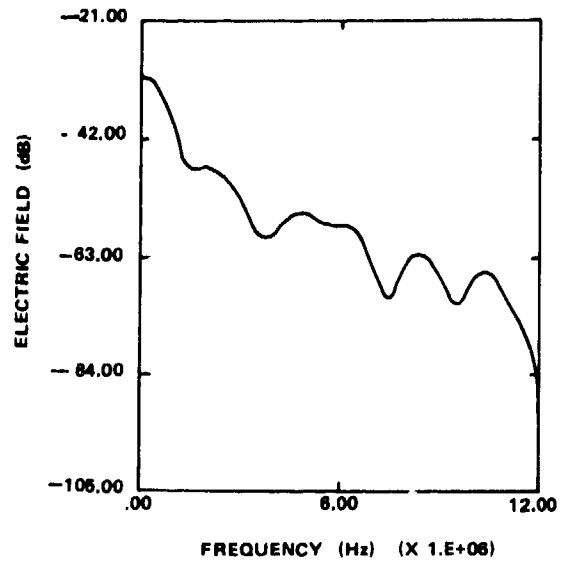

Figure 19. Frequency spectrum of electric field measured at 10 meters.

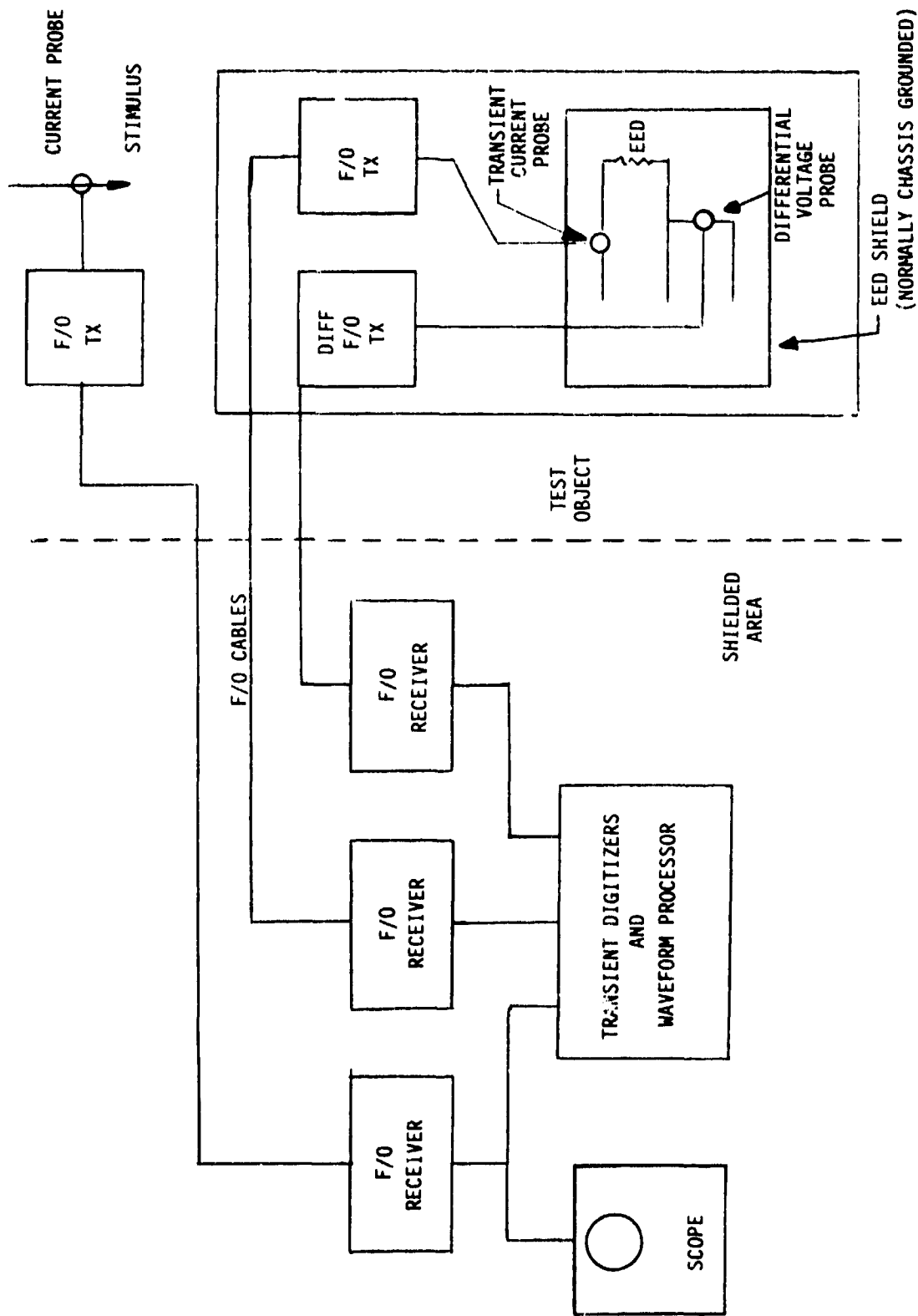

Figure 20. Typical direct strike instrumentation configuration.



Figure 21. EMR test facility (aerial view).

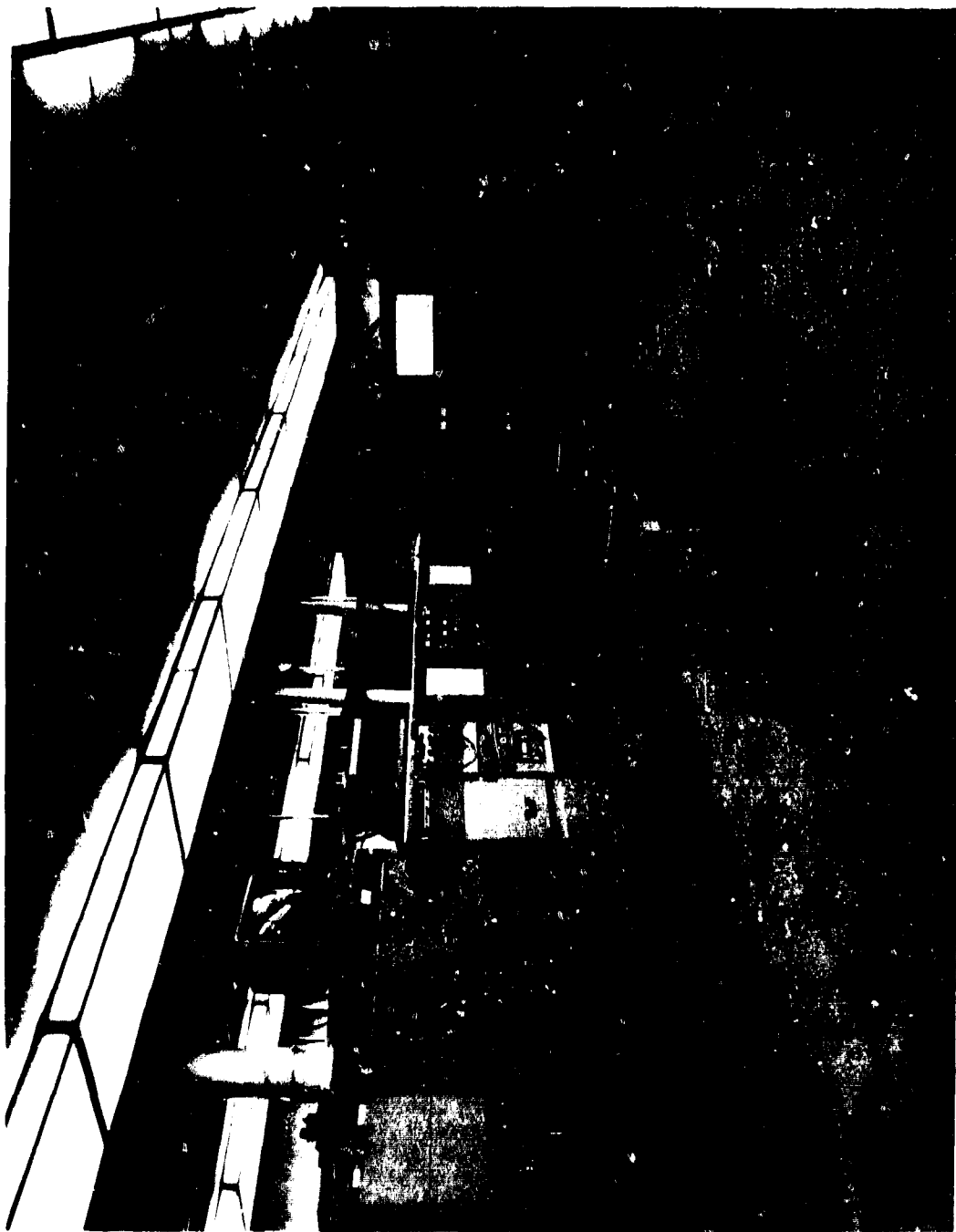

Figure 22. Transmitters 100 kHz to 10 GHz.

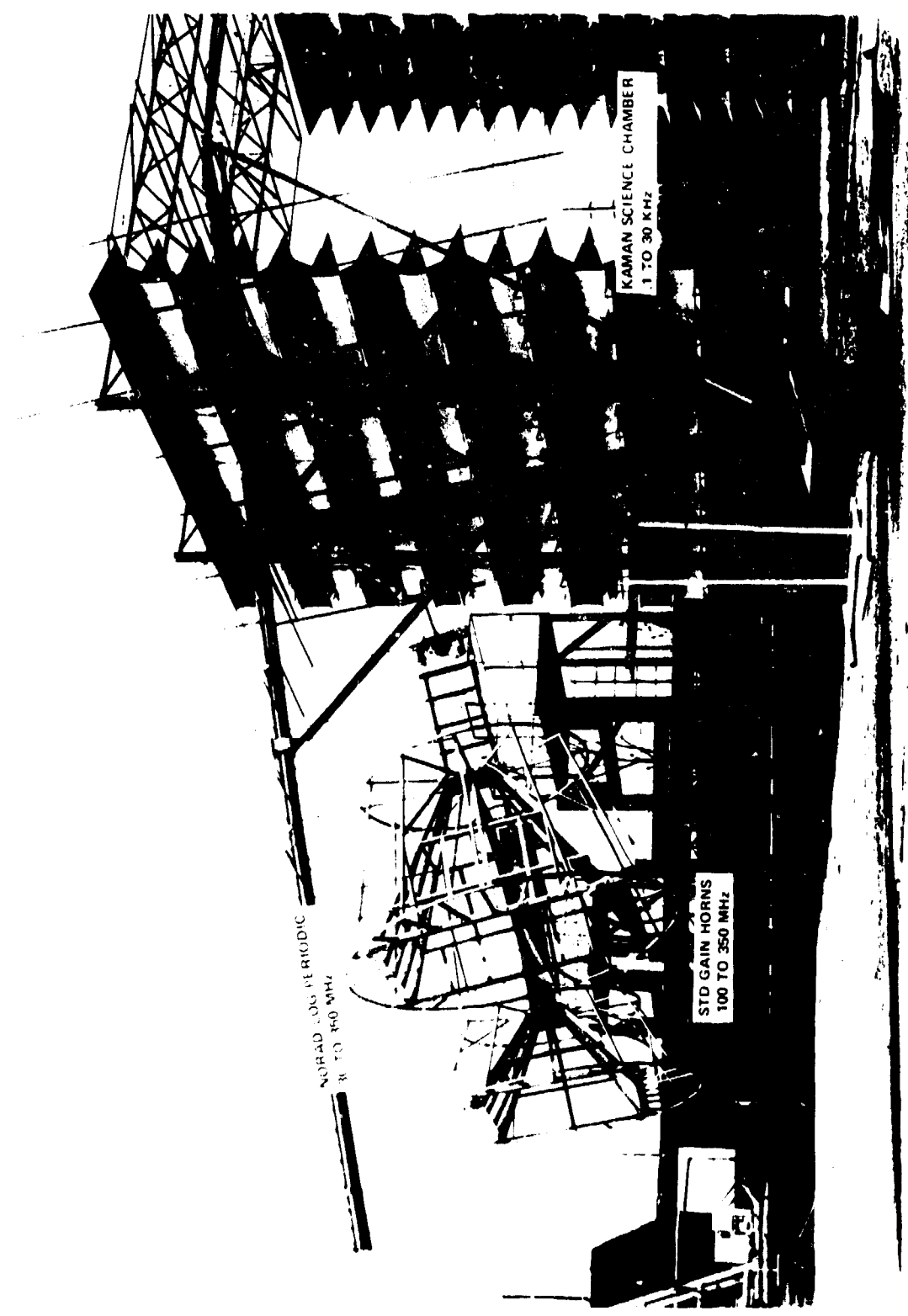

Figure 23. Antenna system (100 to 350 MHz).



Figure 24. Antenna (chamber) (100 kHz to 30 MHz).

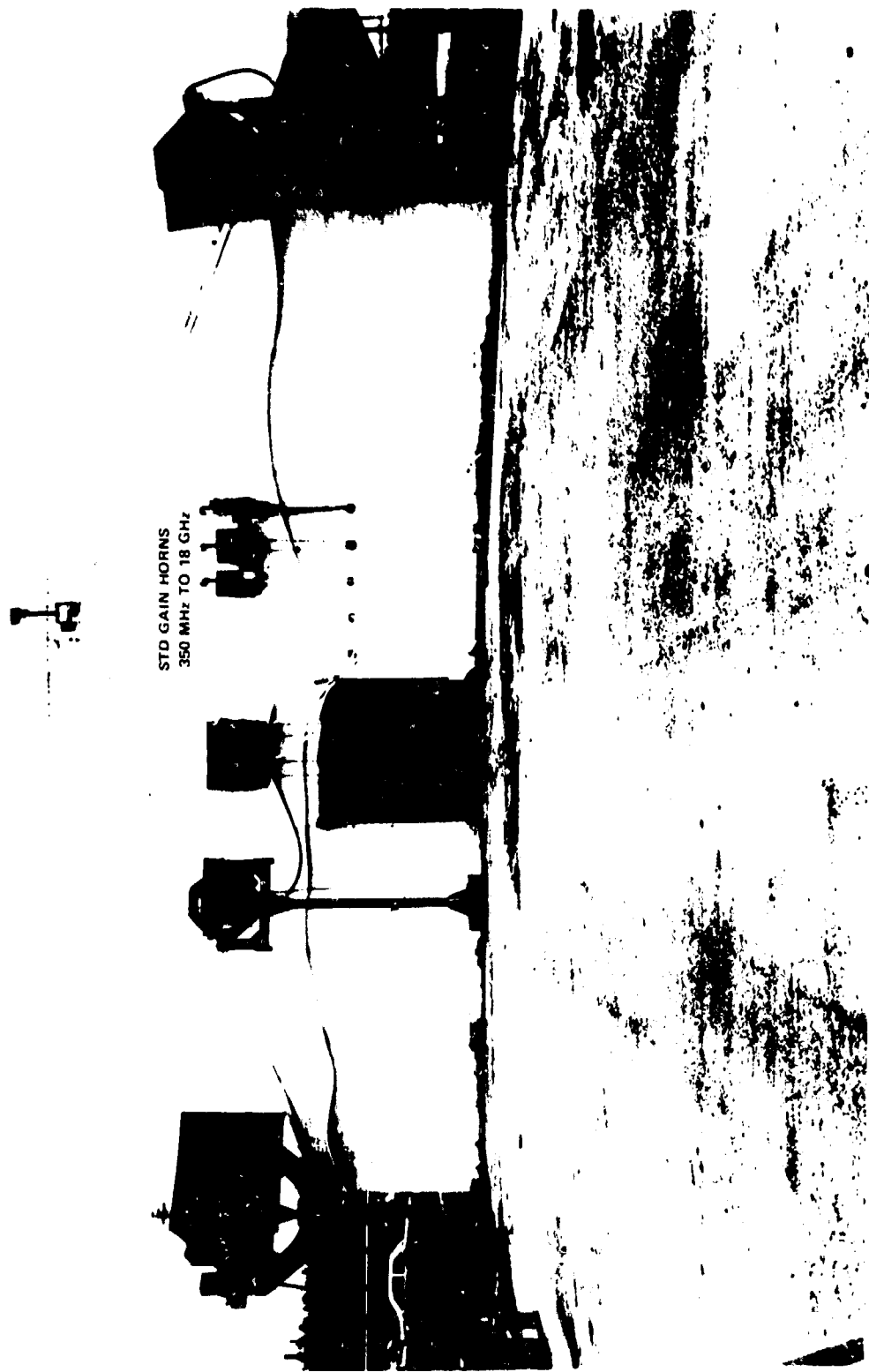

Figure 25. Antenna 350 MHz to 18 GHz.

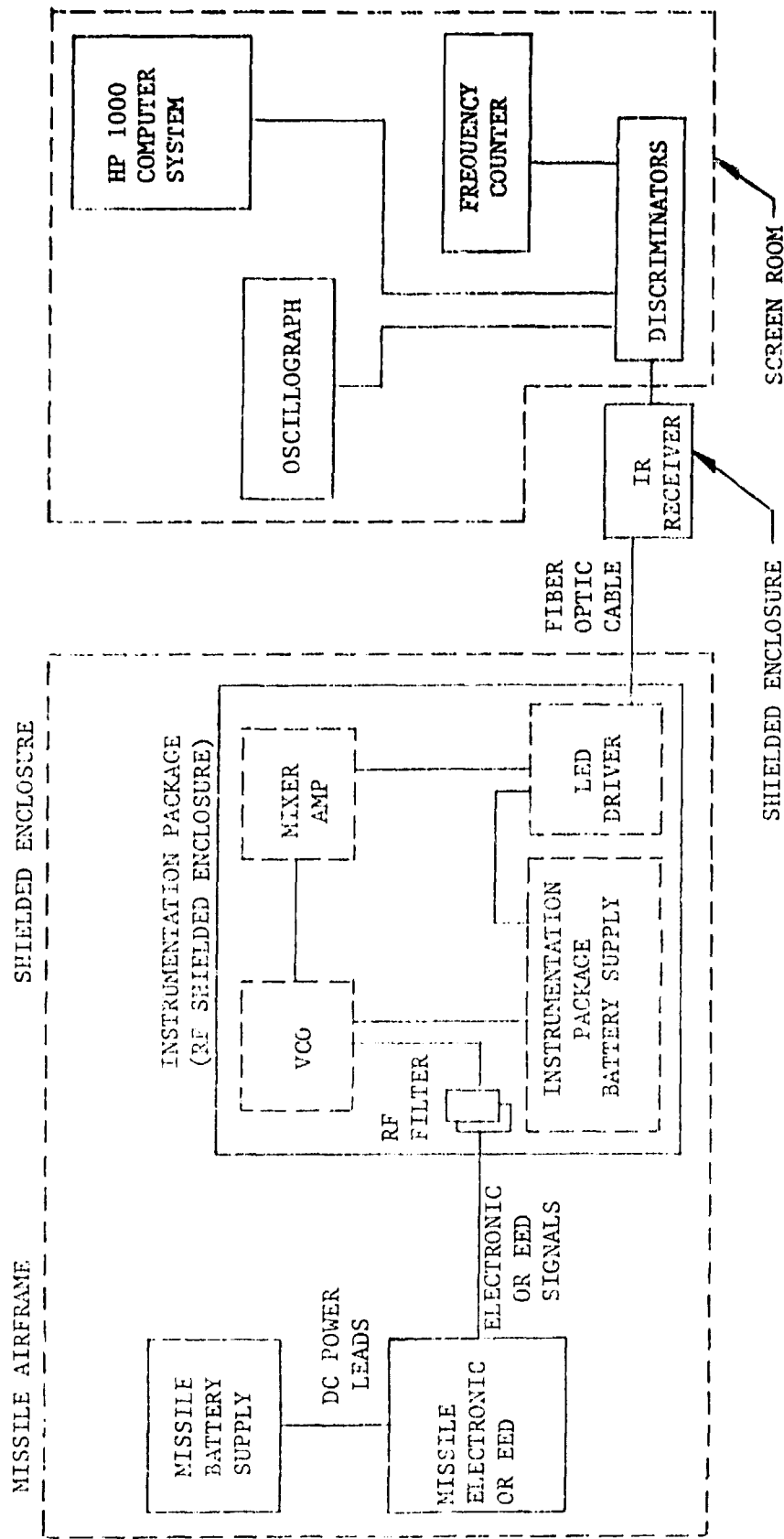

Figure 26. Block diagram of instrumentation of EMRH and EMRO.

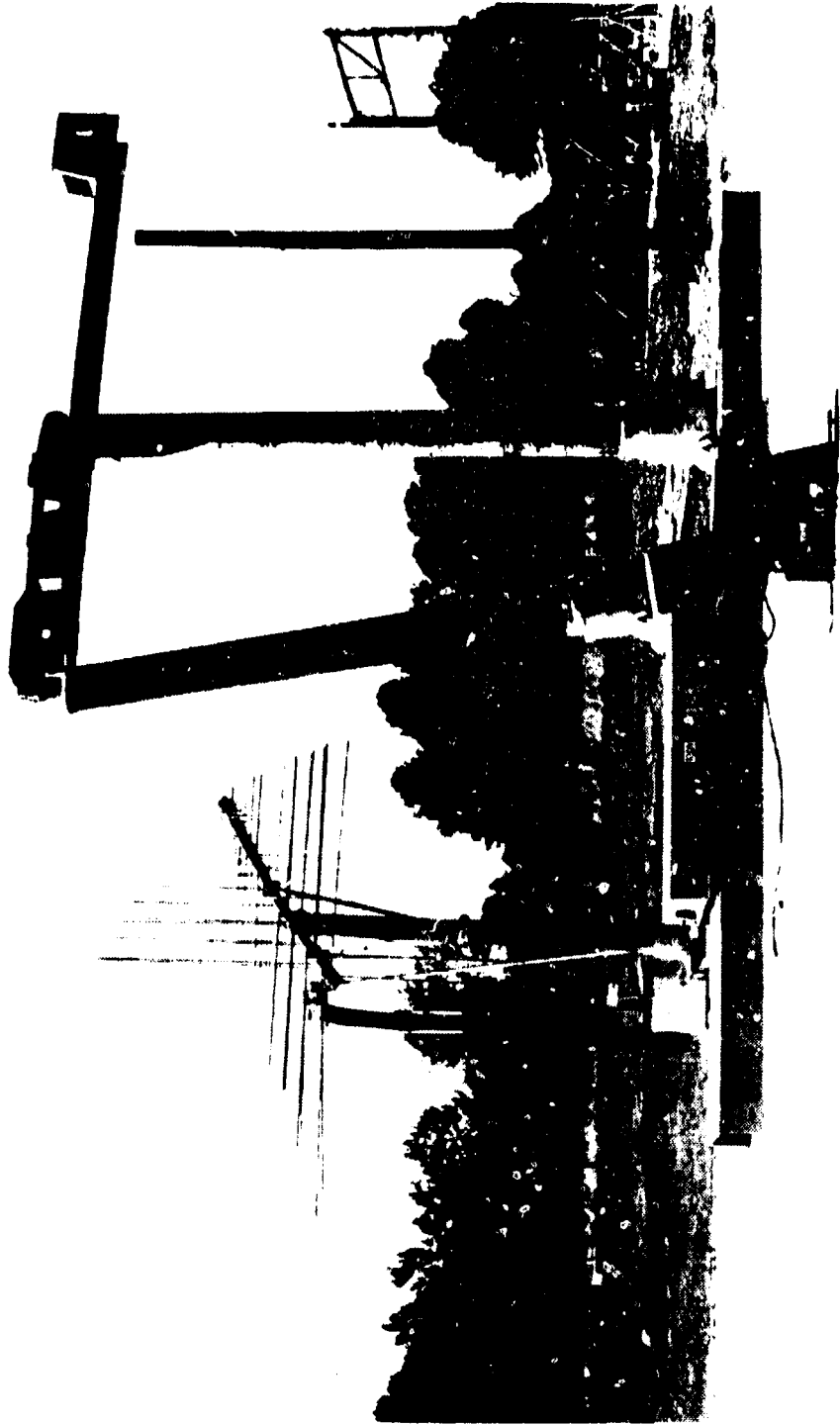

Figure 27. Test fixture - positioner.

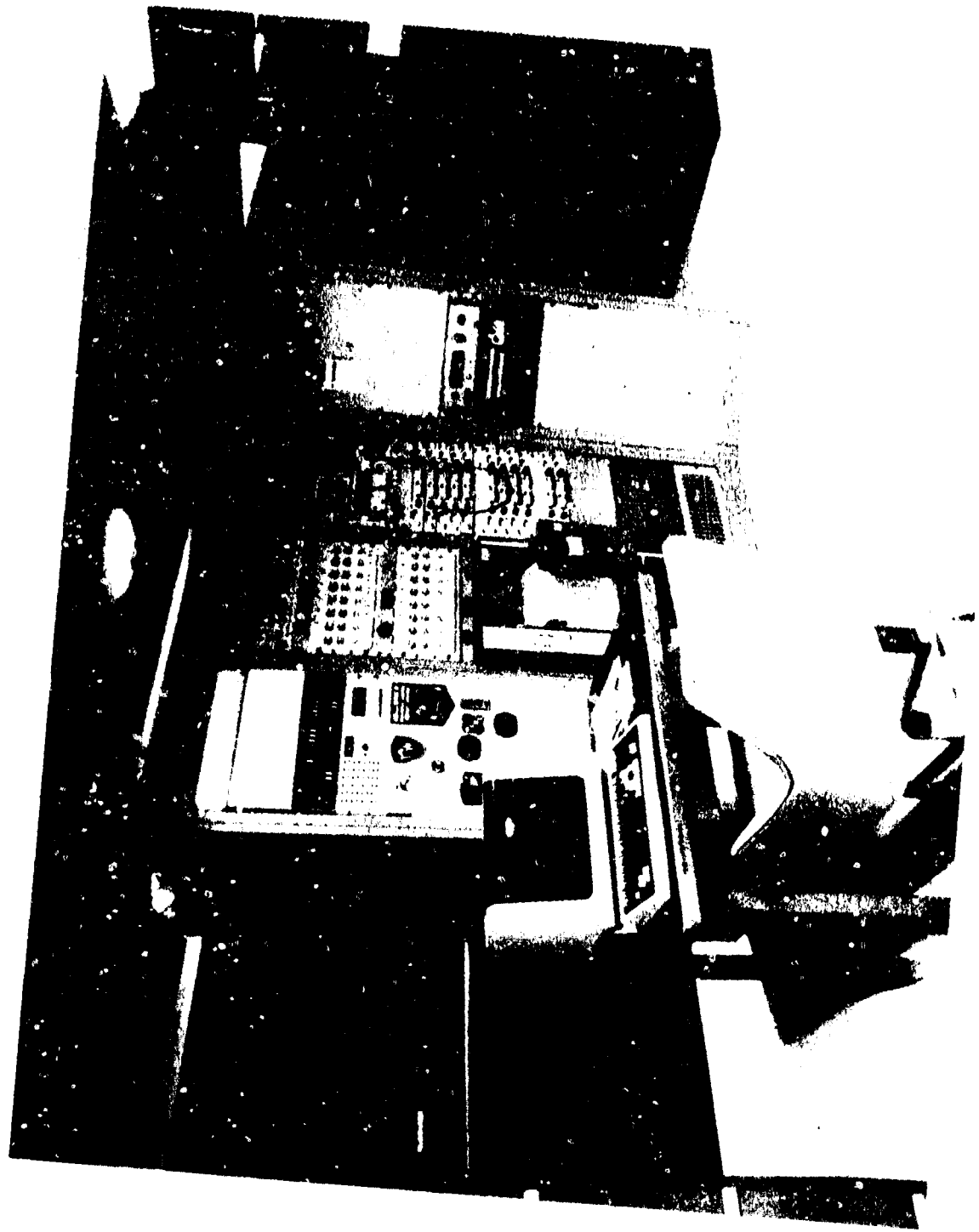

Figure 28. Receiving station and HP 1000 system.



Figure 29. Instrumentation package (EMRO & EMRH).

REFERENCES

1. Department of the Army Transportation Research Command, Ft. Eustis, Virginia, HELICOPTER STATIC ELECTRICITY MEASUREMENTS, June 1962, Interim Report Task 9R38-01-017-30 (Unclassified).
2. McDonnell-Douglas Astronautics Company, SPARTAN IN-PLACE SYSTEM LIGHTNING ANALYSIS, August 1972, MDC G3117m (Unclassified).
3. SAE Committee AE-4 Special Task F, LIGHTNING TEST WAVEFORMS AND TECHNIQUES FOR AEROSPACE VEHICLES AND HARDWARE, 18 September 1975 (Unclassified).
4. Lightning and Transient Research Institute. Letter to DRSMI-RTR, dated 27 January 1981, Subject: SUGGESTED CHANGES TO MICOM TECHNICAL REPORT ET-77-9, "HIGH LEVEL ELECTROMAGNETIC ENVIRONMENTAL CRITERIA FOR ARMY SYSTEMS," P.O. No. H-12461, Recommendations for Revised ESD and Lightning Criteria (Unclassified).
5. US Army Missile Command, Redstone Arsenal, Alabama, ELECTROMAGNETIC FIELD COMMAND UTILIZING B DOT PROBE AND SYSTEM 7 COMPUTER CONTROLLER, 23 June 1976, Report No. Internal Technical Note RT-76-71 (Unclassified).
6. Electric Initiator Handbook, Franklin Institute, Philadelphia, PA, April 29, 1960, Supplement 1962.

DISTRIBUTION

	Copies
US Army Material Systems Analysis Activity ATTN: AMXSY-MP Aberdeen Proving Ground, MD 21005	1
ITT Research Institute ATTN: GACIAC 10 W. 35th Street Chicago, IL 60616	1
Commander US Army Armament, Munitions, and Chemical Command ATTN: SMCAR-TSE-M (Mr. Al Grinoch) Dover, NJ 07801	1
Commander ATTN: STEWS-TE-AM (Mr. T. West) White Sands Missile Range, NM 88002	1
Commander US Army Aviation System Command ATTN: AMSAV-ES (David Alhright) 4300 Good Fellow Blvd St. Louis, MD 63120	1
Commander US Army Materiel Command ATTN: AMCQA-SC (Dickerson/Kendred) 5001 Eisenhower Avenue Alexandria, VA 22333	1
Commander USAICS ATTN: STEEP-MT-DS (D. Kelso) Ft. Huachuca, AZ 85613	1
Pacific Missile Test Center Code 1031 Point Mugu, CA 93042	1
AMCPM-ML-PT	1
-CFT	1
-CC	1
-MPT	1
-HAQ	1
-PE-E	1
-PE-Q	1
-TOE	1
-HDT	1
-ROL-T	1
-VIT	1
-MD	1

DISTRIBUTION (Continued)

	<u>Copies</u>
AMSMI-OA	1
-LC	1
-OR	1
-SF	1
AMSMI-RD, Dr. McCorkle	1
Dr. Rhoades	1
-RD-TE	1
-RD-SE	1
-RD-DP	1
-RD-SI	1
-RD-SS	1
-RD-GC	1
-RD-AS	1
-RD-ST	1
-RD-PR	1
-RD-TE-P, Jack Bissinger	50
-RD-TE-S	100
-RD-CS-R	15
-RD-CS-T	1
-RD-SD	1
-RD-AC	1
-RD-TI	1
-RD-DE	1
-RD-RE	1
-GC-IP, Mr. Bush	1