

MICROCOPY RESOLUTION TEST CHART
NATIONAL BUREAU OF STANDARDS-1963-A

AD-A179 742

AD # 358 87
DTIC FILE COPY (12)

CONTRACT REPORT BRL-CR-563

LASER BALLISTIC
SENSOR DEVELOPMENT

BOEING AEROSPACE COMPANY
MS 8C-64
PO BOX 3999
SEATTLE, WASHINGTON 98124

DTIC
ELECTE
APR 27 1987
S D

JANUARY, 1987

APPROVED FOR PUBLIC RELEASE. DISTRIBUTION UNLIMITED

US ARMY BALLISTIC RESEARCH LABORATORY
ABERDEEN PROVING GROUND, MARYLAND

Destroy this report when it is no longer needed.
Do not return it to the originator.

Additional copies of this report may be obtained
from the National Technical Information Service,
U. S. Department of Commerce, Springfield, Virginia
22161.

The findings in this report are not to be construed as an official
Department of the Army position, unless so designated by other
authorized documents.

The use of trade names or manufacturers' names in this report
does not constitute indorsement of any commercial product.

REPORT DOCUMENTATION PAGE				Form Approved OMB No 0704-0188 Exp. Date Jun 30, 1986	
1a. REPORT SECURITY CLASSIFICATION UNCLASSIFIED		1b. RESTRICTIVE MARKINGS			
2a. SECURITY CLASSIFICATION AUTHORITY		3. DISTRIBUTION / AVAILABILITY OF REPORT			
2b. DECLASSIFICATION / DOWNGRADING SCHEDULE					
4. PERFORMING ORGANIZATION REPORT NUMBER(S) BRL-CR-563		5. MONITORING ORGANIZATION REPORT NUMBER(S)			
6a. NAME OF PERFORMING ORGANIZATION Boeing Aerospace Company		6b. OFFICE SYMBOL (if applicable)	7a. NAME OF MONITORING ORGANIZATION		
6c. ADDRESS (City, State, and ZIP Code) MS 8C-64 PO Box 3999 Seattle, WA 98124		7b. ADDRESS (City, State, and ZIP Code)			
8a. NAME OF FUNDING / SPONSORING ORGANIZATION US Army Ballistic Research Laboratory		8b. OFFICE SYMBOL (if applicable) SLCBBR-LF-F	9. PROCUREMENT INSTRUMENT IDENTIFICATION NUMBER DAAK11-84C-0095		
8c. ADDRESS (City, State, and ZIP Code) Aberdeen Proving Ground, MD 21005-5066		10. SOURCE OF FUNDING NUMBERS			
		PROGRAM ELEMENT NO. RDT&E	PROJECT NO. 1L161102	TASK NO. AH43	WORK UNIT ACCESSION NO.
11. TITLE (Include Security Classification) LASER BALLISTIC SENSOR DEVELOPMENT					
12. PERSONAL AUTHOR(S) Pond, Charles R. (BAC); Texeira, Patrick D. (BAC); Bornstein, Jonathan A. (BRL)					
13a. TYPE OF REPORT Final		13b. TIME COVERED FROM _____ TO _____	14. DATE OF REPORT (Year, Month, Day)		15. PAGE COUNT
16. SUPPLEMENTARY NOTATION					
17. COSATI CODES			18. SUBJECT TERMS (Continue on reverse if necessary and identify by block number)		
FIELD	GROUP	SUB-GROUP			
20	06		ANGULAR MEASUREMENT		
19	04		PROJECTILE MOTION SENSOR		
			GUN MOTION SENSOR		
			LASER DIAGNOSTICS		
19. ABSTRACT (Continue on reverse if necessary and identify by block number)					
<p>A prototype instrument to determine the orientation of a projectile in free flight (i.e., roll, pitch and yaw angles) was developed at Boeing and used to perform tests at the U. S. Army Ballistic Research Laboratory (BRL) at Aberdeen Proving Ground, MD. The instrument incorporated two visible gas lasers (to provide a two color collimated illuminating beam) and a pair of galvanometer beam deflectors to generate a circular angular dither of the output beam. All three angles can be determined from the detected light reflected by a retroreflector/hologram combination mounted on the projectile. The prototype instrument was designed to make three-axis angle measurements on in-flight or in-bore spinning or non-spinning projectiles, and to make two-axis angle measurements of gun tube motion.</p> <p>Tests were performed by both Boeing and BRL personnel at the Aerodynamics Range at BRL during a two-week period in August 1985. The test instrumentation was then left at BRL for additional testing by BRL personnel. A summary of the test results follows:</p>					
20. DISTRIBUTION / AVAILABILITY OF ABSTRACT <input type="checkbox"/> UNCLASSIFIED/UNLIMITED <input type="checkbox"/> SAME AS RPT <input type="checkbox"/> DTIC USERS			21. ABSTRACT SECURITY CLASSIFICATION		
22a. NAME OF RESPONSIBLE INDIVIDUAL JONATHAN A. BORNSTEIN		22b. TELEPHONE (Include Area Code) 301-278-3737		22c. OFFICE SYMBOL SLCBBR-LF-F	

19. Abstract (continued)

- 1) All three angles of a spinning projectile can be measured with a fixed beam and two detectors, where one detector senses fringe amplitude and the other detector senses roll,
- 2) The dither rate (3 kilohertz) was too low for the non-spinning projectiles tests,
- 3) No in-bore data was obtained due to obturation,
- 4) Dynamic measurements of both angle and position of a gun tube were demonstrated.

As a result of the test, the following problem areas have been identified:

- 1) The test results show that a system with a higher dither frequency must be developed,
- 2) The use of two independent lasers complicates the alignment procedure. It would be more reasonable to use a two-color laser (e.g. argon ion laser),
- 3) Some of the data contains an intensity variation at the fundamental of the dither frequency. This could be due to the projectile lying at the edge of the "overlap" of the dithered beams. A larger beam should eliminate this problem and simplify the alignment procedure,
- 4) The reflection coefficient versus angle was assumed to be sinusoidal for the present data reduction algorithm. In practice, the reflection coefficient is not sinusoidal, and the shape of the function changes with relative humidity and laser wavelength. Additional development is needed on an algorithm based on a more realistic analytic model.

ACKNOWLEDGEMENTS

We would like to acknowledge the excellent support by Mr. Donald McClellan, Mr. John Carnahan and Mr. William Thompson (range personnel) during this program. The technical results obtained were due in large part to the cooperation and assistance we received.



Accession For	
NTIS CRA&I	<input checked="" type="checkbox"/>
DTIC TAB	<input type="checkbox"/>
Unannounced	<input type="checkbox"/>
Justification	
By	
Distribution	
Availability Codes	
Dist	Avail and/or Special
A-1	

TABLE OF CONTENTS

	Page
LIST OF ILLUSTRATIONS	ii
SUMMARY	iii
INTRODUCTION	1
OPTICAL TEST SET-UP	2
DATA ACQUISITION ELECTRONICS	5
DATA PROCESSING	8
SOFTWARE DEVELOPMENT	15
TEST RESULTS	22
ANALYTIC MODEL	36
PRELIMINARY DESIGN	41
PHASE II PROGRAM	43
REFERENCES	92
APPENDIX A - ELECTRONIC SCHEMATICS	47
APPENDIX B - COMPUTER PROGRAM	57
DISTRIBUTION LIST	95

LIST OF ILLUSTRATIONS

<u>Figure</u>		<u>Page</u>
1	BRL Optical Breadboard	4
2	Block Diagram of Data Acquisition Electronics	6
3	Reflector Assembly	9
4	Reflection Coefficient	9
5	Technique used in making a 1° Diffraction Angle Hologram	9
6	Angle Modulation of the Fringe Angle	11
7	Bessel Functions for the first 8 orders	11
8	Modulated and Detected Waveforms	13
9	Computer Program Flow Chart	16-21
10	Total Yaw, Round 17452, Laser	25
11	Total Yaw, Round 17452, Shadowgraph	25
12	Yaw Angle, Looking Up-range, Round 17452	26
13	Fringe Angle Calibration, Red	28
14	Fringe Angle Calibration, Blue	28
15	Computer Output, Round 17460	30
16	Yaw Angle versus Z, Round 17460	31
17	Muzzle Angle, Round 17466	33
18	Muzzle Angle, Round 17467	34
19	Muzzle Displacement, Round 17466 and 17467	35
20	Analytical Model Geometry	37
21	Laser Ballistic Sensor Configuration	44

SUMMARY

The prototype instrument to determine the orientation of a projectile in free flight (i. e. roll, pitch and yaw angles) was developed at Boeing and used to perform tests at the U.S. Army Ballistic Research Laboratory (BRL) at Aberdeen Proving Ground, MD. The instrument incorporated two visible gas lasers (to provide a two color collimated illuminating beam) and a pair of galvanometer beam deflectors to generate a circular angular dither of the output beam. All three angles can be determined from the detected light reflected by a retroreflector/hologram combination mounted on the projectile. The prototype instrument was designed to make three-axis angle measurements on in-flight or in-bore spinning or non-spinning projectiles, and to make two-axis angle measurements of gun tube motion.

Tests were performed by both Boeing and BRL personnel at the Aerodynamics Range at BRL during a two week period in August, 1985. The test instrumentation was then left at BRL for additional testing by BRL personnel. A summary of the test results follows: 1) All three angles of a spinning projectile can be measured with a fixed beam and two detectors, where one detector senses fringe amplitude and the other detector senses roll, 2) The dither rate (3 kilohertz) was too low for the non-spinning projectiles tests, 3) No in-bore data was obtained due to obturation, 4) Dynamic measurements of both angle and position of a gun tube were demonstrated.

As a result of the test, the following problem areas have been identified: 1) The test results show that a system with a higher dither frequency must be developed, 2) The use of two independent lasers complicate the alignment procedure. It would be more reasonable to use a two color laser (e.g. argon ion laser), 3) Some of the data contains an intensity variation at the fundamental of the dither frequency. This could be due to the projectile lying at the edge of the "overlap" of the dithered beams. A larger beam should eliminate this problem and simplify the alignment procedure, 4) The reflection coefficient versus angle was assumed to be sinusoidal for the present data reduction algorithm. In practice, the reflection coefficient is not sinusoidal, and the shape of the function changes with relative humidity and laser wavelength. Additional development is needed on an algorithm based on a more realistic analytic model.

INTRODUCTION

This document is the final report on Phase 1 of contract DAAK11-84-C-0095. The contract is the first part of a program whose goal is to develop hardware for measuring the angular orientation of projectiles in-flight and in-bore, and the angular response of gun tubes during firing. The technology, originally developed for measuring the pitch angle of models in the Boeing Transonic Wind Tunnel, was shown to be applicable to spinning projectile yaw angle measurement in a prior test program (Reference 2) at the U.S. Army Aerodynamics Range. Significant improvements to the measurement techniques were made in the present contract.

A two-laser breadboard system was assembled at Boeing for evaluation at the Ballistic Research Laboratory. The breadboard was designed to make 3-axis angle measurements on in-flight and in-bore non-spinning or spin-stabilized projectiles, and 2-axis angle measurements on gun tubes. For spin-stabilized projectiles, three-axis angle measurements were demonstrated. Signals were obtained from non-spinning projectiles, but could not be converted into meaningful information due to the inability of the breadboard optical system to measure the orientation of projectiles possessing high yawing rates. No in-bore data was obtained due to degradation of the incident laser beam quality resulting from the leakage of hot combustion gases around the projectile. Dynamic measurement of both angle and position were demonstrated for the gun tube tests.

The report contains a description of the breadboard system, the modifications required for the various measurement tasks, the test conditions, and the test results. Data reduction algorithms developed by Boeing are in Appendix B. Preliminary design information for Phase II hardware, based on the results of this evaluation, are included.

OPTICAL TEST SET-UP

The test setup consists of an optical unit and supporting electronics located in the range together with data acquisition and processing equipment placed in the control room. The optics will be discussed first.

Figure 1 shows the arrangement of optical elements on a standard 0.6x1.2 meter setup board. Red and blue lasers are used to provide orthogonal angle measurements on the projectile. The beams are combined in a dichroic cube beamsplitter and then directed to the filter-splitter. A lens in the red beam is used to adjust the beam diameter at the filter-splitter so that the red and blue beams have the same diameter when they exit the unit.

The filter-splitter is a Boeing device (U. S. Patent No. 4,329,059) that spatially filters the outgoing beam while transmitting most of the return beam energy to the photodetectors. The coaxial red and blue beams at the input to the filter-splitter are focused by a microscope objective lens onto a small elliptical mirror on a tilted glass plate which spatially filters the reflected beams and insures that the red and blue beams are collinear. The elliptical mirror is small compared to the diffraction pattern of the return beams from the reflector on the projectile, so more than 90% of the return energy passes on to the photodetectors.

A two-axis galvanometer type beam deflector generates a circular dither (or conical scan). The relay lens forms an image of the filter-combiner mirror in the focal plane of the large collimating lens. The function of the relay lens is to reduce lateral motion of the spot at the projectile. (The translation is zero in the plane where the combination of the collimating and relay lenses forms an image of a galvanometer mirror.) The output beam is collimated and reflected into the projectile path with a pair of mirrors (not shown).

The reflector assembly consists of a hologram and a cube corner reflector, as described in Reference 2, with modifications that allow 3-axis angle measurement. The hologram has a central circular holographic grating surrounded by an annular grating with equal area but orthogonal fringe orientation. Red and blue spectral filters that match the hologram profiles are sandwiched between the hologram and the reflector.

The circular dither on the outgoing beam produces orthogonal sinusoidal components to match the axes of the dual hologram. Amplitude and phase of a pair of dither frequency harmonics (for each color) are used to find the orientation of the projectile body axis. Roll about the body is proportional to the phase difference between the deflector driver and the fundamental component of the return signal.

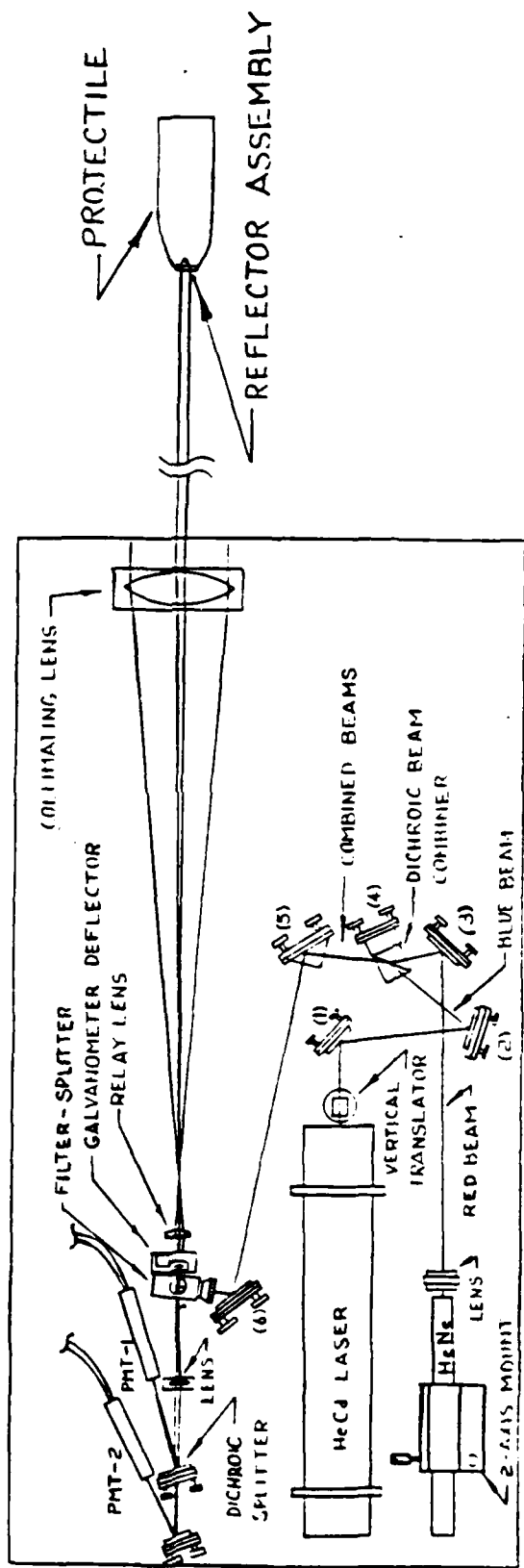

Figure 1. BRL Optical Breadboard.

DATA ACQUISITION ELECTRONICS

Figure 2 is a block diagram of the data Acquisition Electronics (DAE). The DAE was used to collect range or calibration data. The photodetectors were Hamamatsu R761 photomultipliers (PMT), a head-on type with a half inch (13mm) diameter photocathode. The PMT has ten dynode stages, typical current gain of 5.8×10^5 , and a spectral response from 185nm to 850nm, peaking at 420nm. The light entering the PMT's was optically filtered for the two optical wavelengths before application to the PMT's.

Both the red and blue signal channels are identical with the exception of the overall gain. Load resistors for the PMT's were 10k ohms. At the optical assembly each PMT output was amplified by a HP465A amplifier with a gain of 20db and filtered by a Krohn-Hite 3342 filter/amplifier. One section of the Krohn-Hite filter is used as a low pass filter with a cutoff frequency of 100Hz and a gain of 20db. The low pass section drives the high pass section resulting in a bandpass with cutoff frequencies of 100Hz and 24KHz. The high pass section of the Krohn-hite filter drives approximately 100 feet of terminated coax cable between the optical assembly and the control room. The variable gain capability of the HP467A was used to adjust the input amplitude to the tape recorder and analog-to-digital converter to approximately one volt RMS.

All timing for the system is synchronously derived from a very stable frequency source, an HP8460B signal generator operating at 576Khz. Quadrature (i.e. the two signals are out of phase by 90 degrees) signals at 3Khz drive the elevation and azimuth galvanometers.

An EMI7000 tape recorder was used to record all test data. Each signal output from the HP467A's was applied to three tape recorder channels and one channel of the ADC/Computer Interface. The gain settings of the three tape recorder channels were adjusted to accommodate signals that were the expected nominal and plus and minus 50% from nominal. Other sources of data recorded by the EMI7000 are shown in Figure 2.

The direct memory access, DMA, of the HP9836 computer was used as a transient waveform recorder to collect real time range and calibration data for immediate and future data reduction. All four channels of the ADC/Computer Interface are sampled synchronously at a 36Khz rate and data transferred to the computer by DMA at 144 kilobytes.

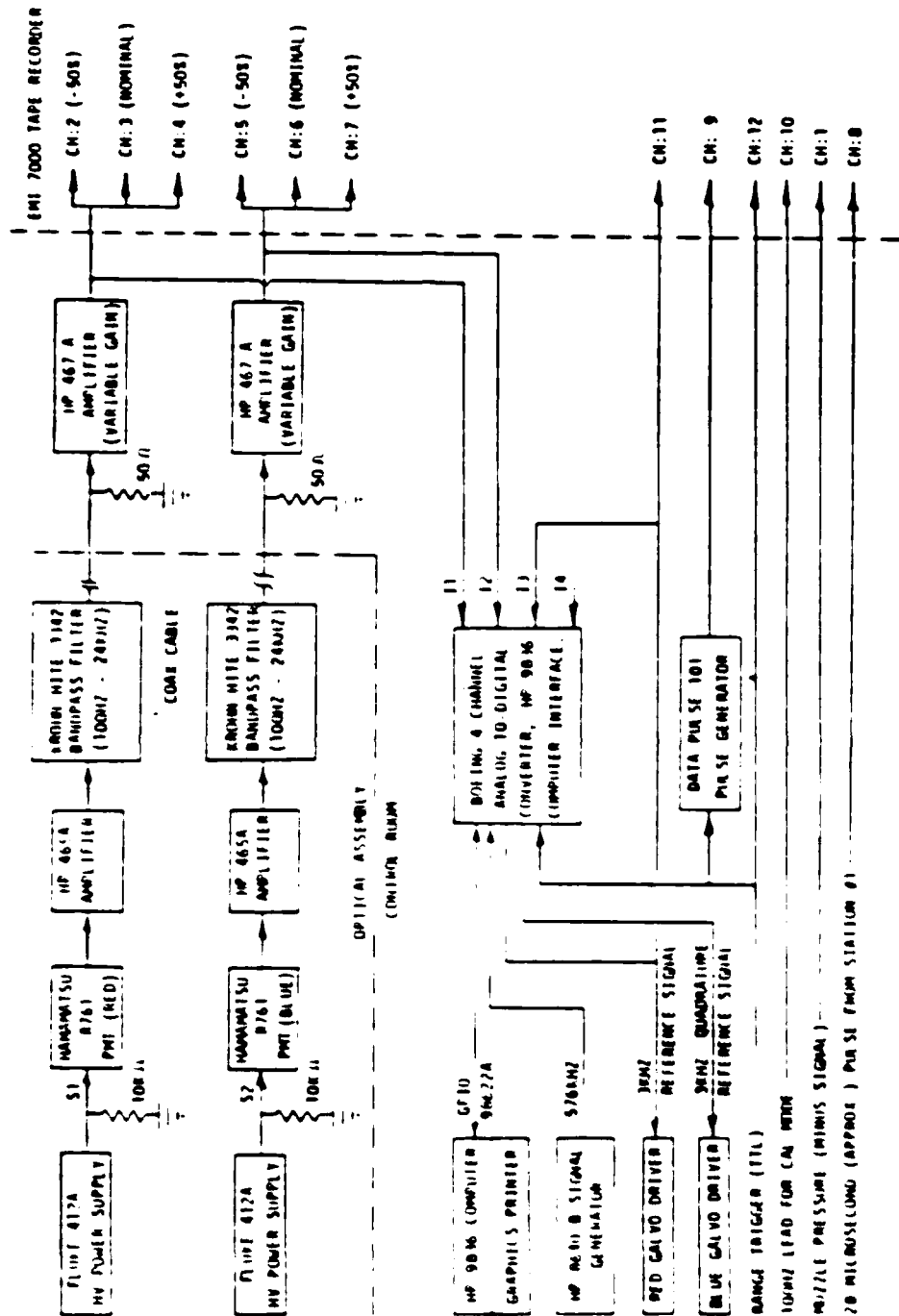

Figure 2. Block Diagram of Data Acquisition Electronics.

Initiation of range data collection was synchronized to the first positive crossing of the 3Khz signal driving the red galvanometer after a range trigger is received. This synchronization was incorporated to facilitate the phase measurement required in processing the data. When range data was collected, the red, blue, and 3Khz reference signals were sampled and stored by the computer.

Each hologram/retroreflector combination was calibrated by placing it in a test fixture which allowed it to be rotated in two orthogonal planes, simulating pitching and yawing motion. During this procedure the red and blue signals and the x and y positions of the gimbal positioning device were also sampled and stored by the computer. Appendix A contains the schematics for the data acquisition electronics.

DATA PROCESSING

Since data processing is dependent on the characteristics of the holographic grating and corner reflector combination, the reflector assembly will be described first.

The reflector assembly, Figure 3, consists of a holographic grating and a cube corner reflector. The reflector assembly is small and rugged with typical dimension of 6.4 mm diameter and 5 mm high. The input light beam is diffracted by the hologram into the zero and higher order beams. For clarity, only the zero order and one of the signed first order beams are shown in the figure. These two beams are retroreflected by the cube corner and again diffracted by the hologram. Note that the zero and first order beams are again diffracted into zero order and first order beams. The emerging composite zero order consists of a number of parallel component beams. These component beams follow different optical paths, consequently they interfere constructively or destructively, depending on relative phase difference. Figure 4 shows the modulation of the reflection coefficient due to optical interference as a function of the angle of incidence.

The resulting fringe angle of the hologram corner cube combination is dependent on the fringe angle of the hologram when it is produced, the index of refraction and height of the corner cube reflector. Figure 5 is a diagram showing the optical set up for producing the hologram. The diffraction angle for the hologram is

$$\theta_a = 2 \sin^{-1}(\lambda/2s)$$

where λ is the wavelength of the laser source and s is the grating period.

The fringe angle for the hologram and corner cube reflector combination is approximately

$$\theta_r = n\lambda/2h\theta_a$$

where h is the height and n is the index of refraction of the cube corner reflector.

If the change in angle of the retroreflector is unidirectional then the amplitude of the reflection coefficient could be used to measure the angle of the retroreflector. In reality the amplitude does change due to effects other than changes in the angle of the cube corner reflector (e.g. noise, changes in laser power output). To determine the direction of change of the retroreflector angle, quadrature signals are required. With quadrature

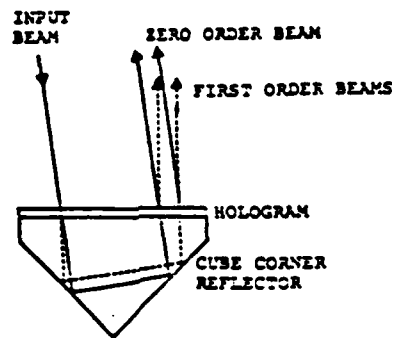

Figure 3. Reflector Assembly.

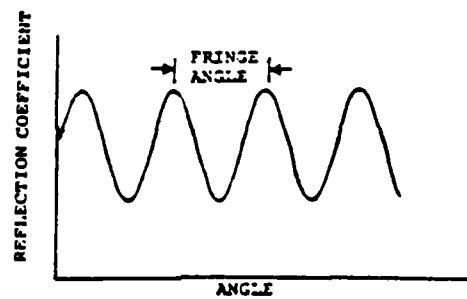

Figure 4. Reflection Coefficient.

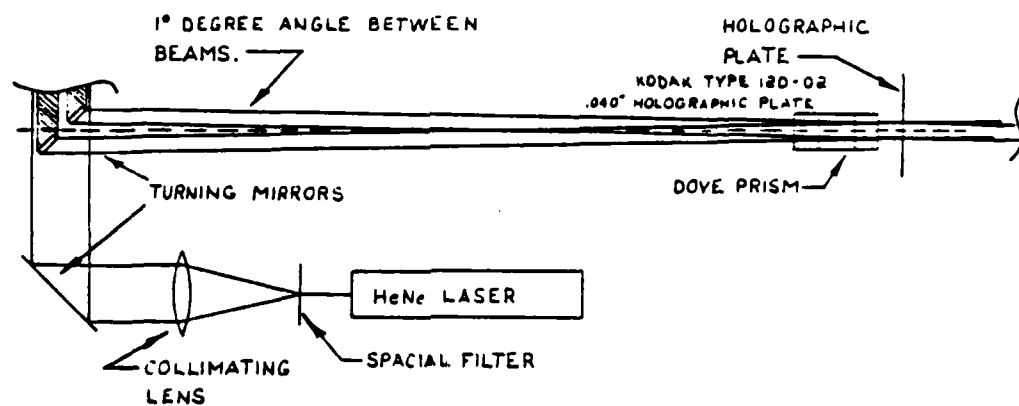

Figure 5. Technique used in making a 1° Diffraction Angle Hologram.

(i.e. signals are out of phase by 90°) signals phase can be measured, direction of phase change determined, and the amplitude effects which are not related to angle can be eliminated.

The spin of a spinning projectile provides the modulation which enables data reduction. For a slow spin or non-spinning projectile the laser beam is dithered (angle modulated) in order to change the incident angle of the input light beam at the retroreflector. This is accomplished by the azimuth and elevation galvanometers and beam directing optics.

Angle modulation of the beam across the fringe pattern shown in Figure 4 results in quadrature relationships existing between frequency components of the photodetector current which are harmonically related to the modulating frequency. Figures 6 through 8 support the analytical description to follow from which the software algorithm was developed. This analytical description is for one axis only and is not as rigorous as the description for the analytic model which was developed at the end of the program.

Figure 6a represents the photodetector output (equivalent to the reflection coefficient) and Figure 6b the angle modulation at the dither frequency. Figure 6c is the photocurrent for the angle modulation shown in Figure 6b. I is the photodetector current output as a function of the angle of the corner cube reflector and $\theta_r = 2\pi$ (yaw angle)/(fringe angle). I_p is one half the peak-to-peak value of the photodetector current and t is time. m_p is the peak deviation of the angle modulation in radians and ω_m the modulation frequency of the dither in radians per second.

The equations that describe the modulation effects of the dither are

$$\begin{aligned}
 I(\theta_r, t) &= I_p \sin(\theta_r + m_p \sin \omega_m t) \\
 &= I_p \sin \theta_r \cos(m_p \sin \omega_m t) + \\
 &\quad I_p \cos \theta_r \sin(m_p \sin \omega_m t) \\
 &= I_p \sin \theta_r [J_0(m_p) + 2J_2(m_p)\cos 2\omega_m t + \\
 &\quad 2J_4(m_p)\cos 4\omega_m t + \dots] + \\
 &\quad I_p \cos \theta_r [2J_1(m_p)\sin \omega_m t + 2J_3(m_p)\sin 3\omega_m t + \dots]
 \end{aligned}$$

where the values of $J_n(m_p)$ are determined from the graph of Bessel Functions, Figure 7. Note that the amplitudes of the odd and even harmonics above are quadrature functions. The amplitude of the odd harmonics is proportioned to the cosine of θ_r and the amplitude of the even harmonics is proportional

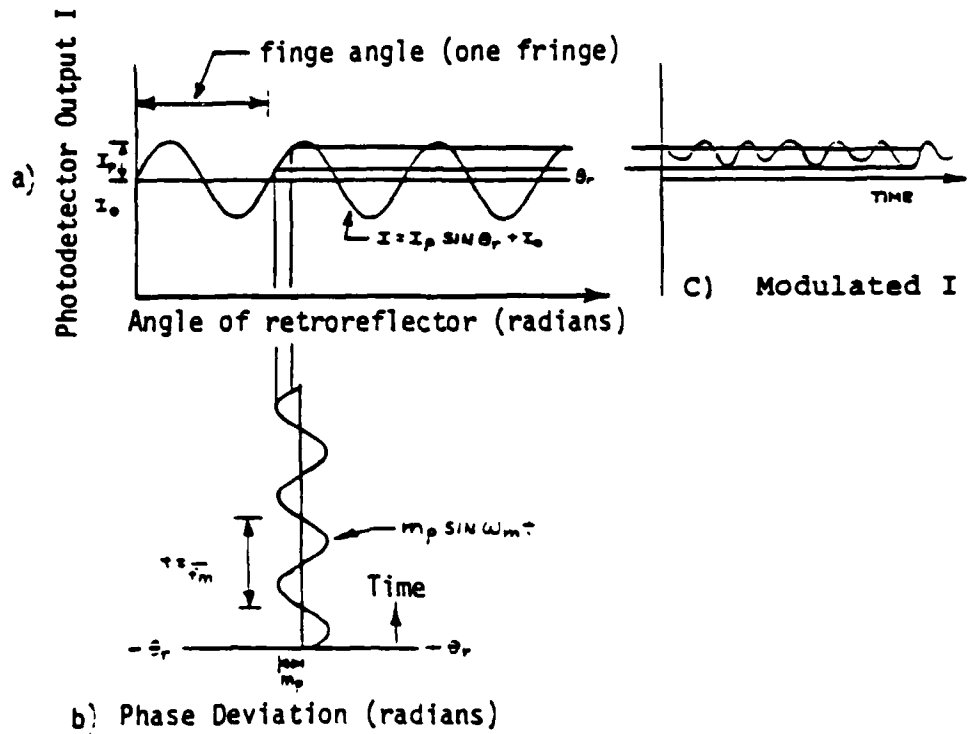

Figure 6. Angle Modulation of the Fringe Angle.

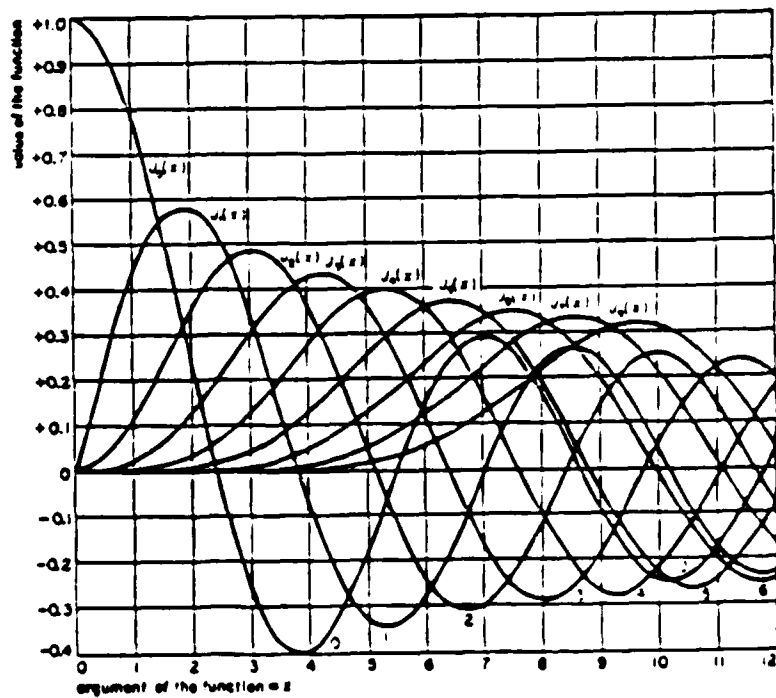

Figure 7. Bessel Functions for the first 8 orders.

to the sine of the θ_r . The fundamental and second harmonic were used in the breadboard system.

Figure 8a is the photodetector output with a graphic representation showing the relation between the fundamental and second harmonic components of a reflected beam for a small value of m_p . The figure shows the relationship between the reflected signal and the dither signal, when $\theta_r = 0, \pi, 2\pi, \dots$. The fundamental frequency dominates the signal when $\theta_r = 0, \pi, 2\pi, \dots$. The second harmonic dominates the signal when $\theta_r = \pi/2, 3\pi/2, 5\pi/2, \dots$. Note the π radian phase reversal between the positive and negative slopes for the fundamental and the positive and negative peaks for the second harmonic. Figure 8b and c are the fundamental and second harmonic filtered from the photodetector current by bandpass filters. The amplitude factor m_p is chosen equal to approximately .27 resulting in equal peak-to-peak amplitudes for the fundamental and second harmonic. It is important to note that the waveforms of the fundamental and second harmonic are in quadrature.

Figure 8d shows the desired quadrature terms as a function of cube corner reflector angle. To arrive at these outputs a phase comparison must be made between the fundamental and the modulating frequency for the fundamental, and between the second harmonic and twice the modulating frequency for the second harmonic. Devices such as balanced mixers used as a phase detector, followed by a suitable low pass filter, would produce the desired output. For the computer algorithm the envelope amplitude and sign is determined for each cycle of reference phase.

After amplitude and phase detection the quadrature signals of Figure 8c and d can be written as

$$E_1(\theta_r) = I_p(2J_1(m_p))\cos \theta_r$$

$$E_2(\theta_r) = I_p(2J_2(m_p))\sin \theta_r$$

where $E_1(\theta_r)$ is the detected envelope of the fundamental and $E_2(\theta_r)$ the detected envelope of the 2nd harmonic. Then

$$\begin{aligned} E_2(\theta_r)/E_1(\theta_r) &= I_p 2J_2(m_p)\sin \theta_r / I_p 2J_1(m_p)\cos \theta_r \\ &= J_2 \sin \theta_r / J_1 \cos \theta_r = (J_2/J_1) \tan \theta_r \end{aligned}$$

and

$$\theta_r = \tan^{-1} [J_1 E_2(\theta_r) / J_2 E_1(\theta_r)]$$

The sign of the argument of the arctan identifies the quadrant for each quarter-fringe cycle. Comparison of the signs of the numerator and denominator of the present and previous measurements are used to identify quadrant boundary

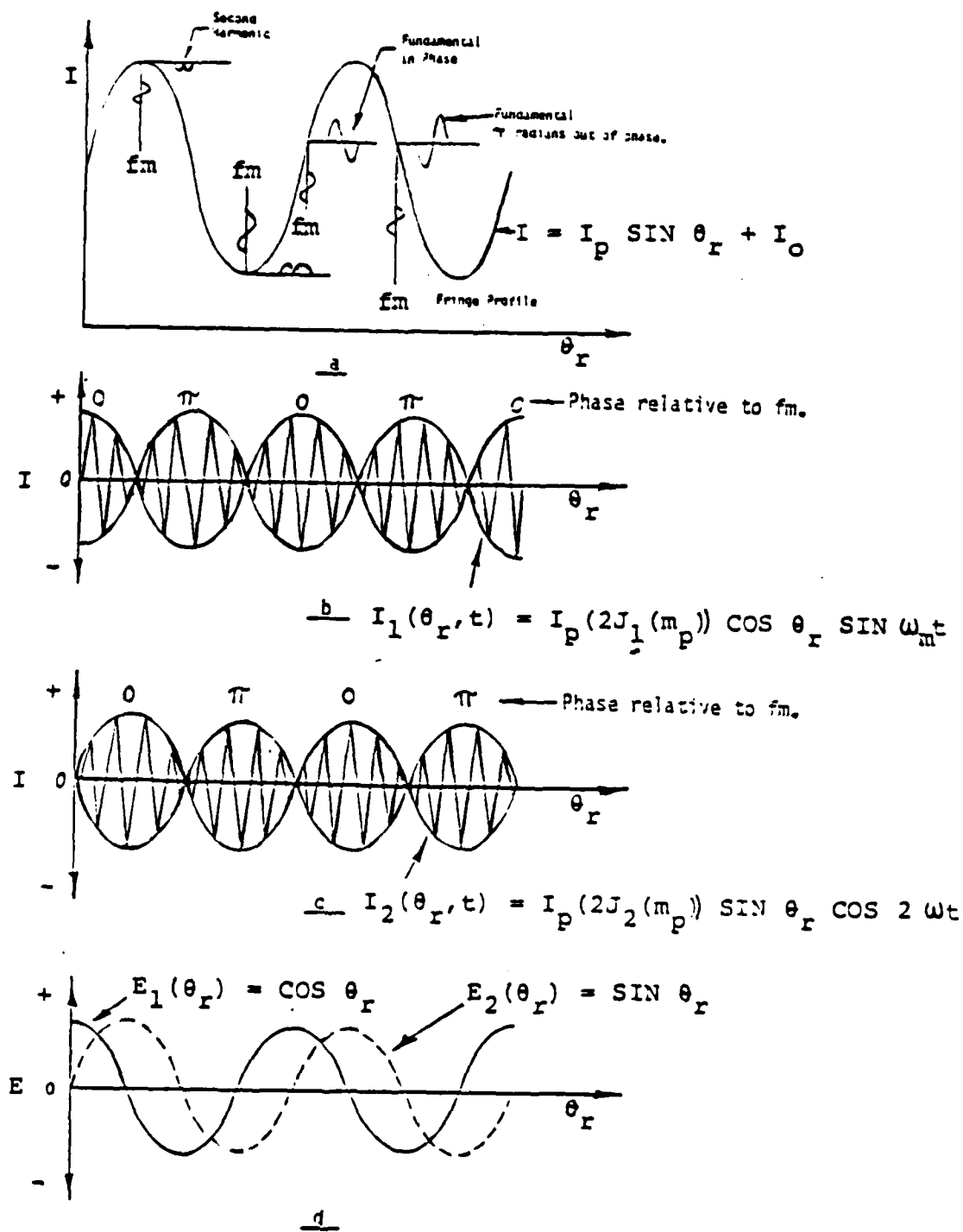

Figure 8. Modulated and Detected Waveforms.

crossings. Consequently, fractional fringe quarter cycles can be measured, and the boundary direction crossing used to sum quarter fringe cycles.

SOFTWARE DEVELOPMENT

Software was developed using the preceding analytical description. It is important to note that the software was a development effort intended for diagnostics and for the future determination of the requirements for complete data reduction by a HP9836 computer or the range computer.

The two programs (written in the BASIC language) are included as Appendix B. One software program is used for collecting and processing range data when a range trigger is received and the other is used to collect calibration data for a given hologram cube corner reflector combination. The calibration program was derived from the range program, consequently parts of the program are not integral to the calibration process. Figure 9 is the flow chart for the range data collection and processing program.

Range data consisted of the outputs from the two photomultipliers and a 3Khz reference (the 3Khz signal driving the elevation galvanometer). For each cycle of the 3Khz reference there are twelve data samples for each channel of the ADC/Computer Interface. Transfer of data was done using the Basic TRANSFER command. Data was transferred to a DMA Buffer in real time for a predetermined time after receiving a range trigger. At the end of this predetermined time, determined by the DMA Buffer size, the binary data was converted to decimal and placed in a program array for use by the program.

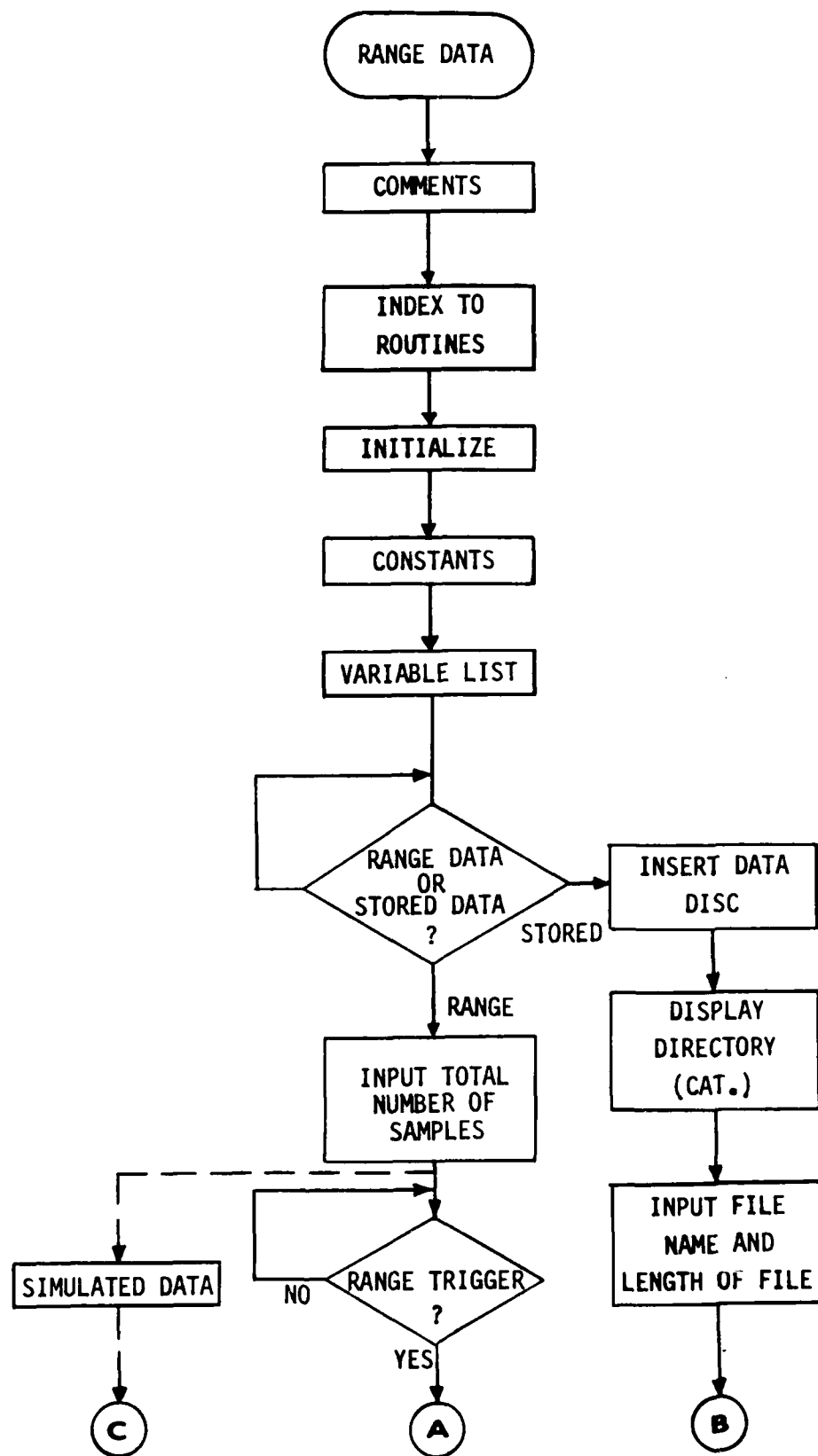

Figure 9. Computer Program Flow Chart

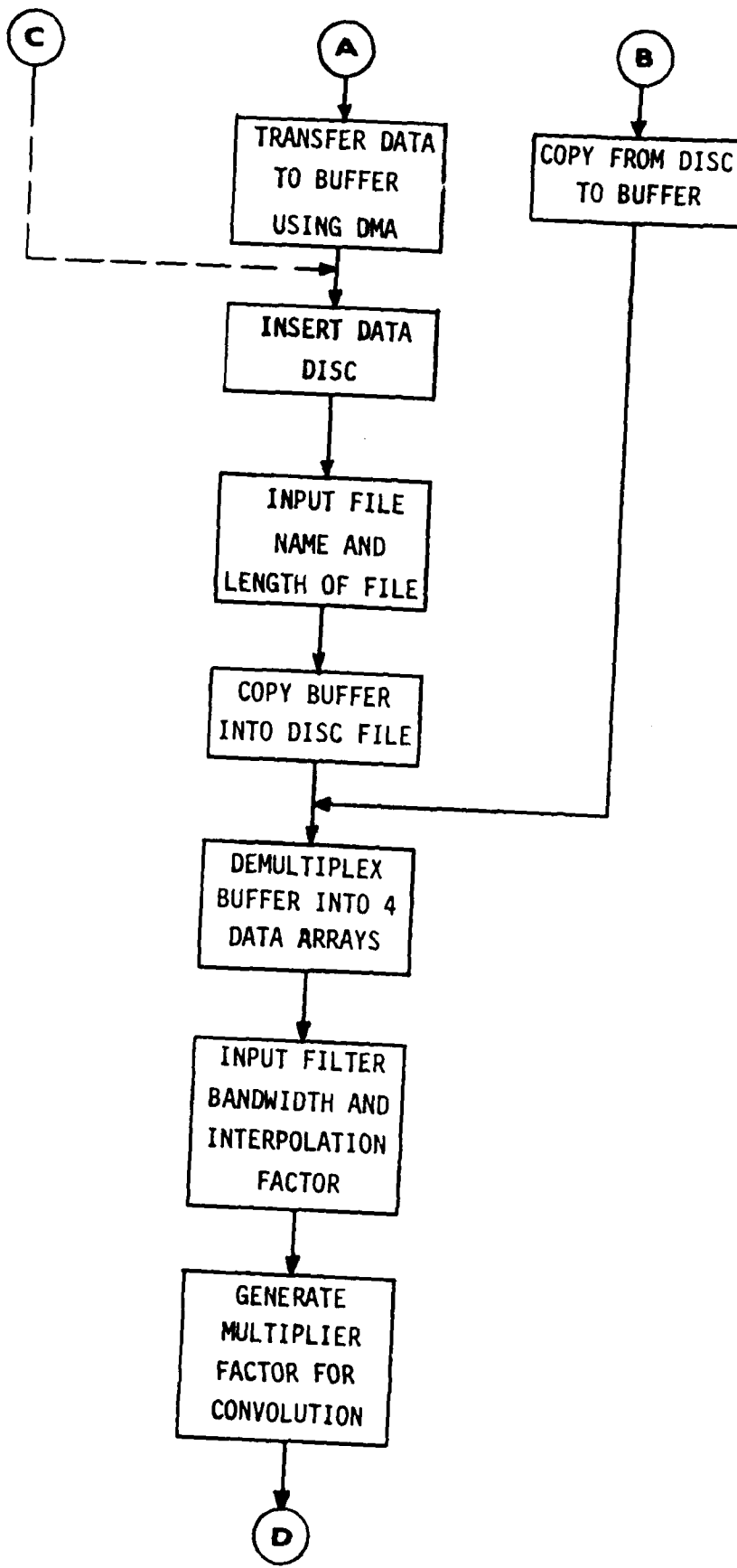

Figure 9. Computer Program Flow Chart

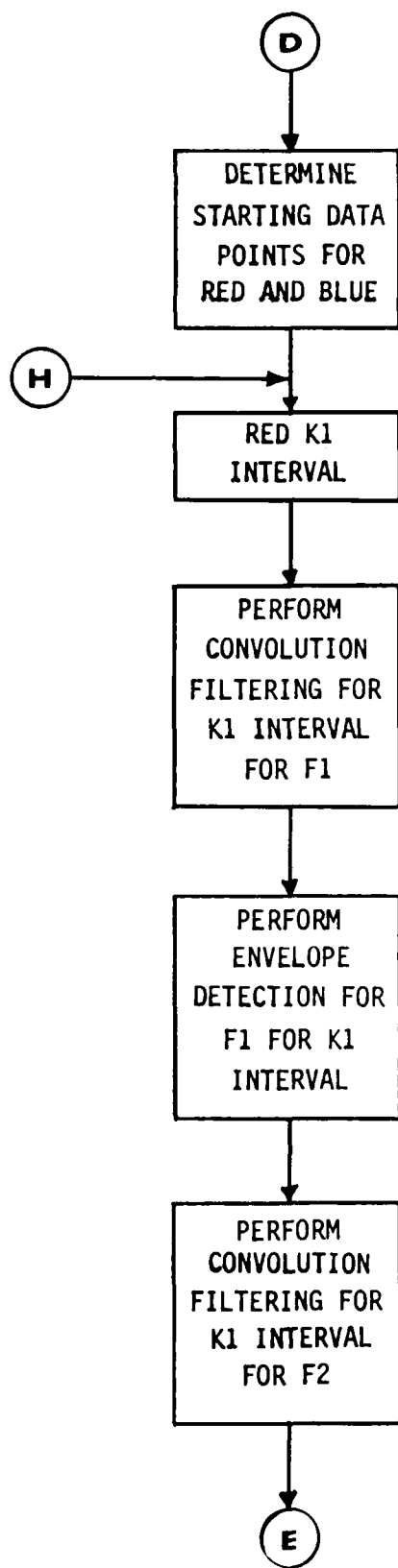

Figure 9. Computer Program Flow Chart (continued)

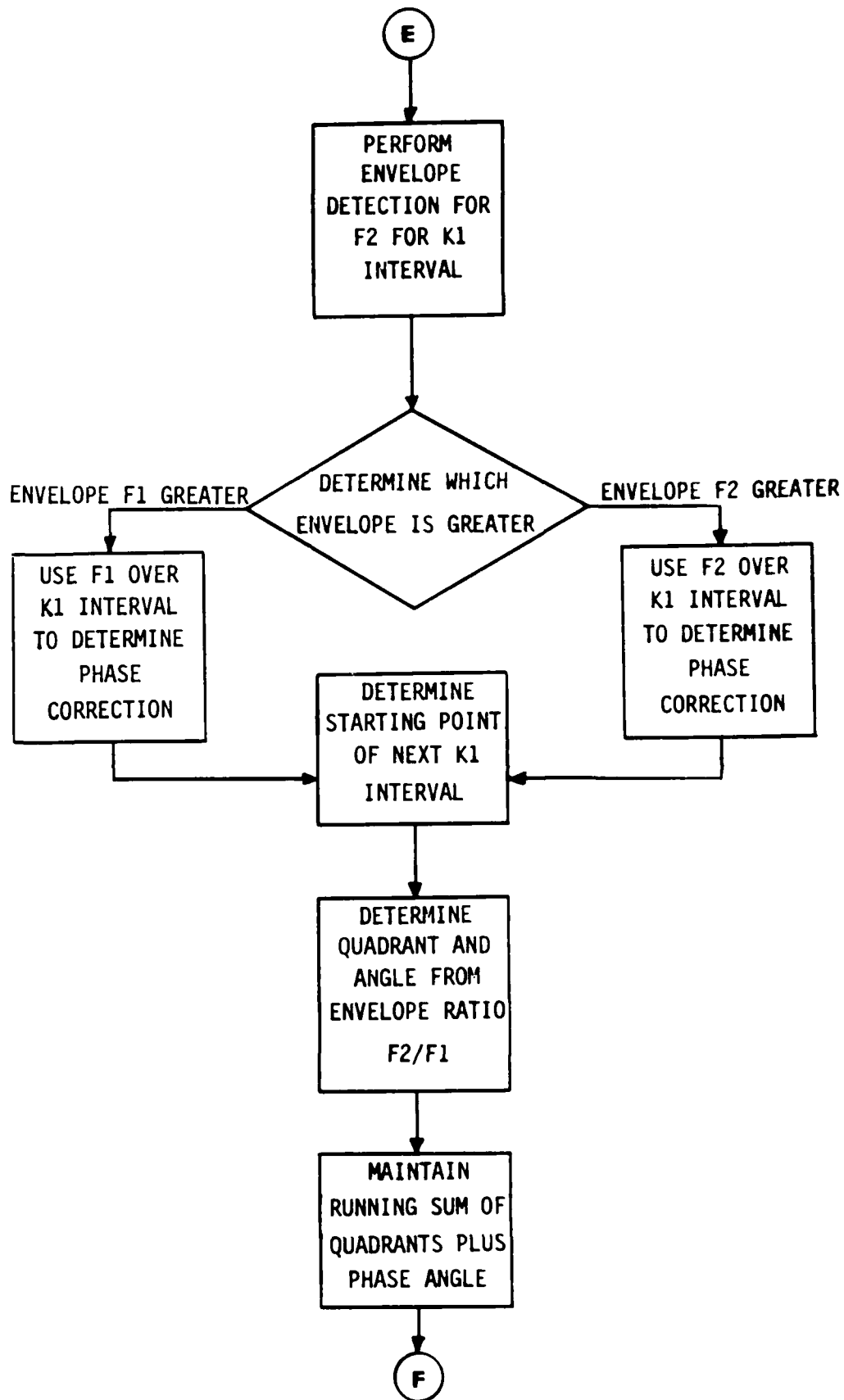

Figure 9. Computer Program Flow Chart (continued)

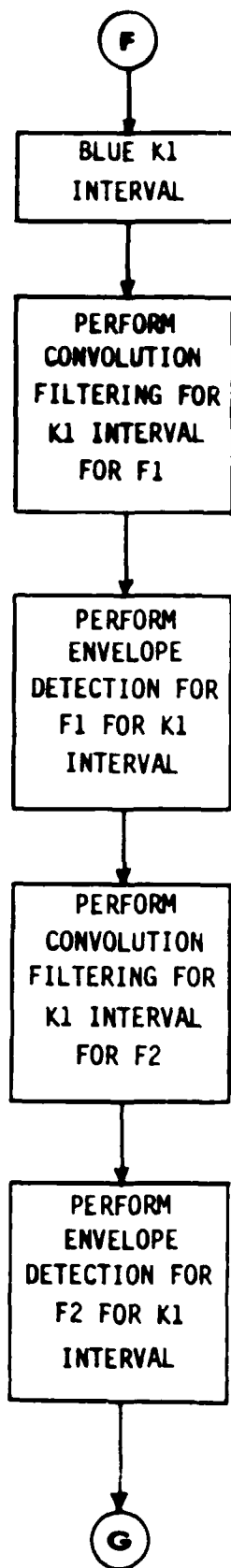

Figure 9. Computer Program Flow Chart (continued)

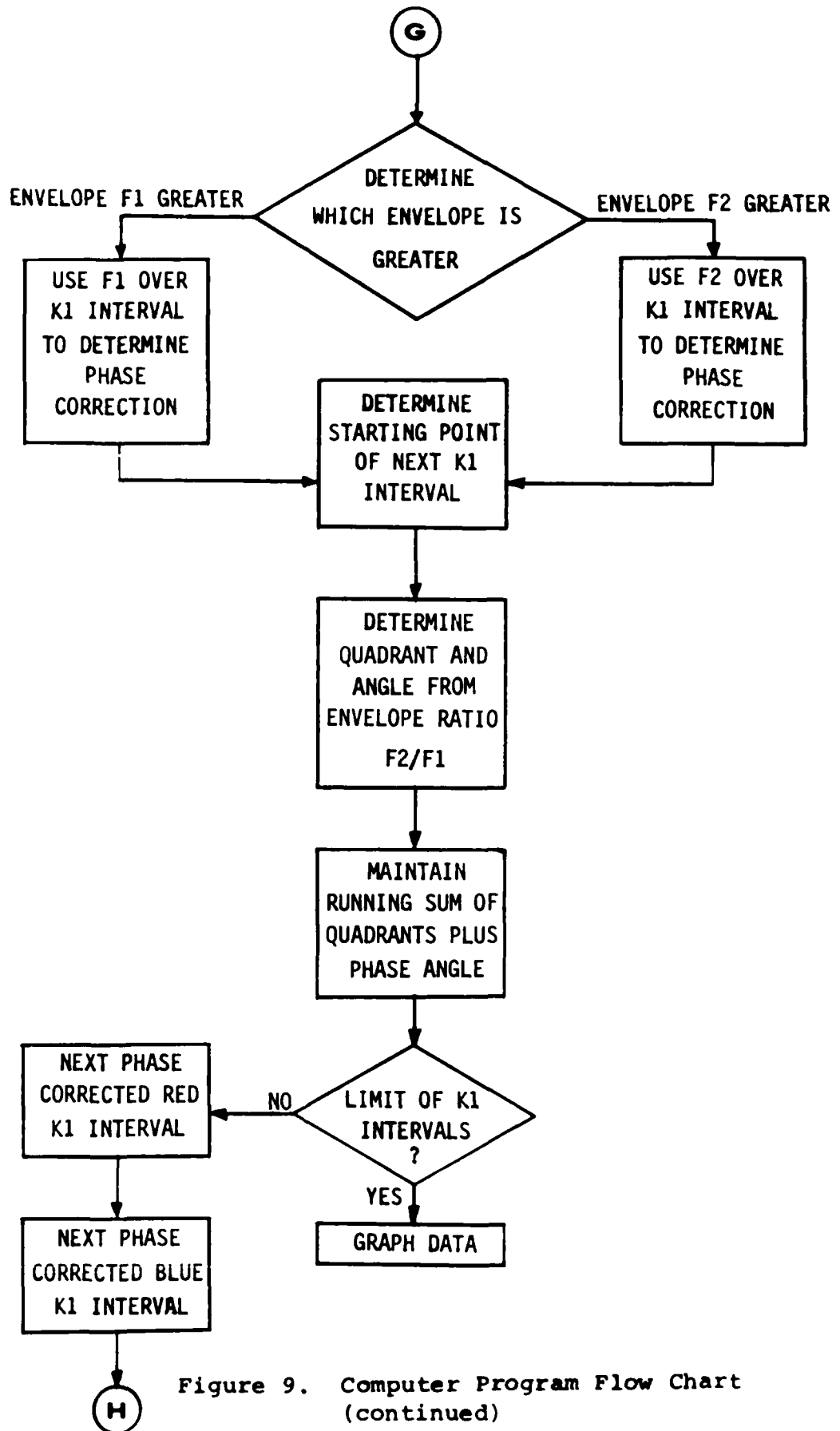

Figure 9. Computer Program Flow Chart (continued)

TEST RESULTS

The test configuration and results of tests performed jointly by BAC and BRL personnel are summarized in Table 1 below. Following the table is a discussion of the reduced data listed in the order of those rounds which produced reducible data.

TABLE 1 - ROUND FIRING SUMMARY

NO.	ROUND TYPE	DATA SET	CONFIGURATION	RESULTS
17450	30 mm spinning		Scotchlite on nose, to check for obturation	No range trigger
17452	30 mm spinning	Run-1	Single 1 ⁰ hologram Red beam set for yaw Blue beam set for roll Flight path 30 m	Data on tape No range trigger
17453	30 mm spinning	Run-2	"	No data No range trigger
		Run-3	No retro, range trigger check	
		Run-4	No retro, range trigger check	
		Run-5	No retro, range trigger check	
17458	30 mm spinning	Run-6	Same as round 17452	Early range trigger No data
		Run-7	No retro, range trigger check	
17460	20 mm no spin	Run-8	2-axis, 1 ⁰ hologram Cal-3A Flight path 15 m	Data on tape and in computer
17461	20 mm no spin	Run-9 Cal-4	"	"
		Run-10	No retro, range trigger check	
		Run-11	No retro, range trigger check	

TABLE 1 - ROUND FIRING SUMMARY

NO.	ROUND TYPE	DATA SET	CONFIGURATION	RESULTS
17464	30 mm	Run-12 Cal-5	Set up for in-bore measurement. Folding mirror in blast room	No data due to obturation
17465	25 mm	Run-13 Cal-6	Muzzle angle and linear displacement setup. Reflector in collar on muzzle.	Collar moved No data
17466	25 mm	Run-14 Cal-6	"	Displacement and angle data Gun moved back 16mm in last two shots
17467	25 mm	Run-15 Cal-6	"	Muzzle pressure gauge failed
17468	25 mm	Run-16	"	
17469	25 mm	Run-17	"	

Round 17452 - The purpose of this round was to test the feasibility of determining pitch, roll, and yaw angles of a spinning projectile with a fixed beam (no dither). The 30 mm round was fitted with a single 1° hologram and cube corner reflector. The calculated fringe angle is 6 milliradians, based on the hologram diffraction angle and the specified height of the retroreflector.

A retroreflector whose far-field pattern consisted of two spots was used to facilitate roll measurement. The optics for the blue beam were adjusted to form the far-field pattern of the return beam on a slit in front of the photomultiplier so an electrical pulse occurs each time the projectile rolls 180° . The reflection assembly on a spinning projectile generates a frequency modulated (fm) signal, where the number of cycles per half revolution is proportional to the total yaw angle (Reference 2). The polar angle is proportional to the time between the minimum frequency point of the fm signal (red beam) and the electrical pulse from the blue beam.

Figure 10 shows the laser measurement results of total yaw angle as a function of time. Data obtained from the analysis of a series of orthogonal spark shadowgraphs obtained for this round are shown in Figure 11. The laser measurement is quite similar in shape to the smooth curve fitted to the shadowgraph data. It is interesting that the minimum yaw points at 10m are not on the smooth curve, but they show up on both the raw shadowgraph data and the reduced laser data.

Figures 12a and b are laser and shadowgraph measurements of the horizontal and vertical yaw angle components. The square boxes on the laser curve mark the points at which the pair of far-field blue spots line up with the slit. The projectile rolls 180° between each pair of square boxes, thus the laser angle sensor can measure all three projectile angles.

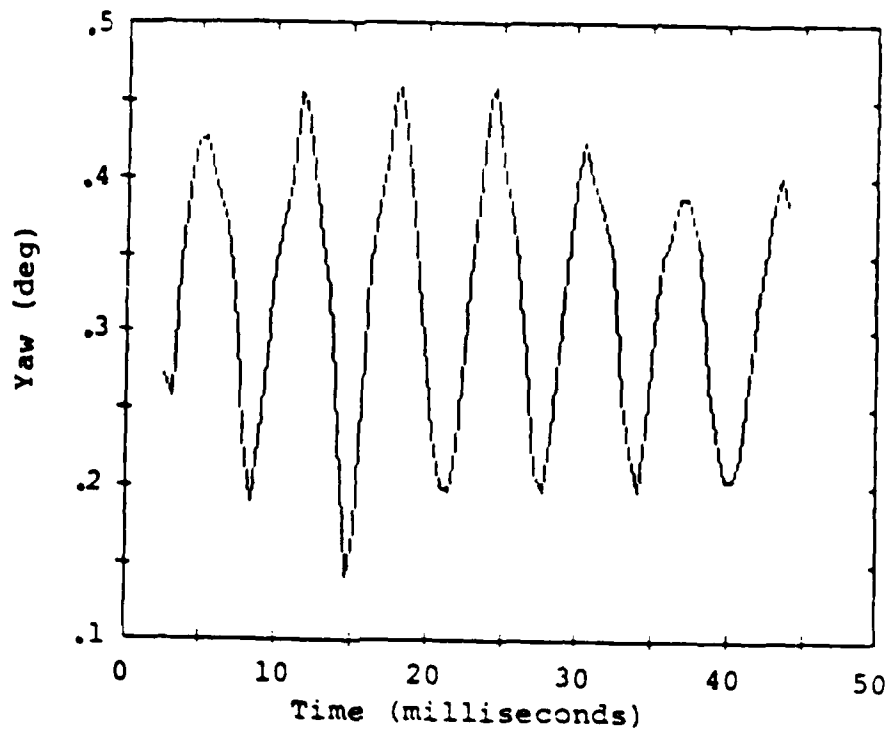

Figure 10. Total Yaw, Round 17452, Laser.

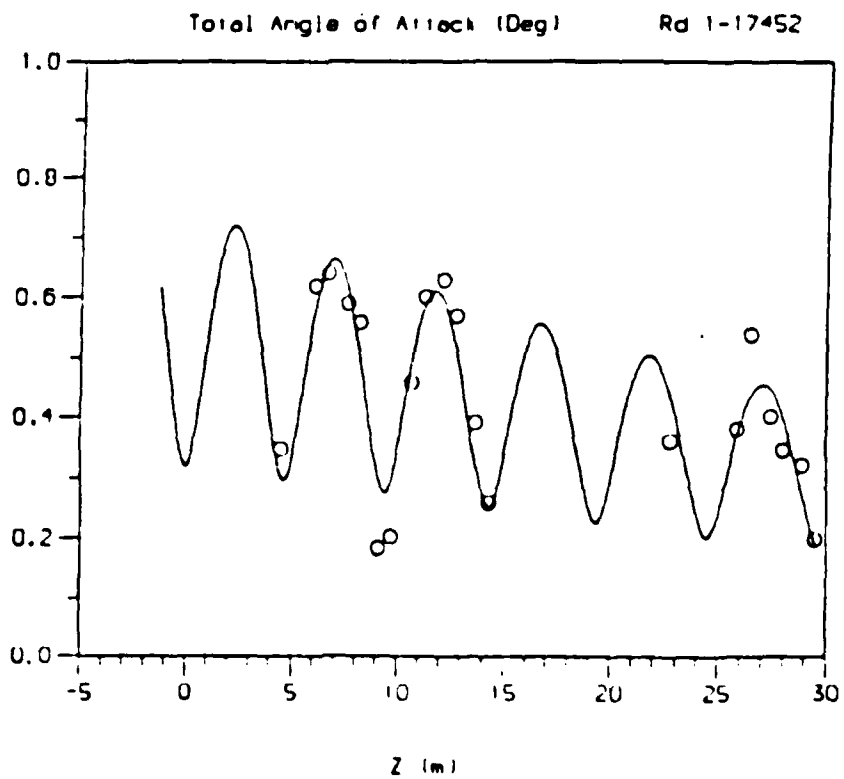
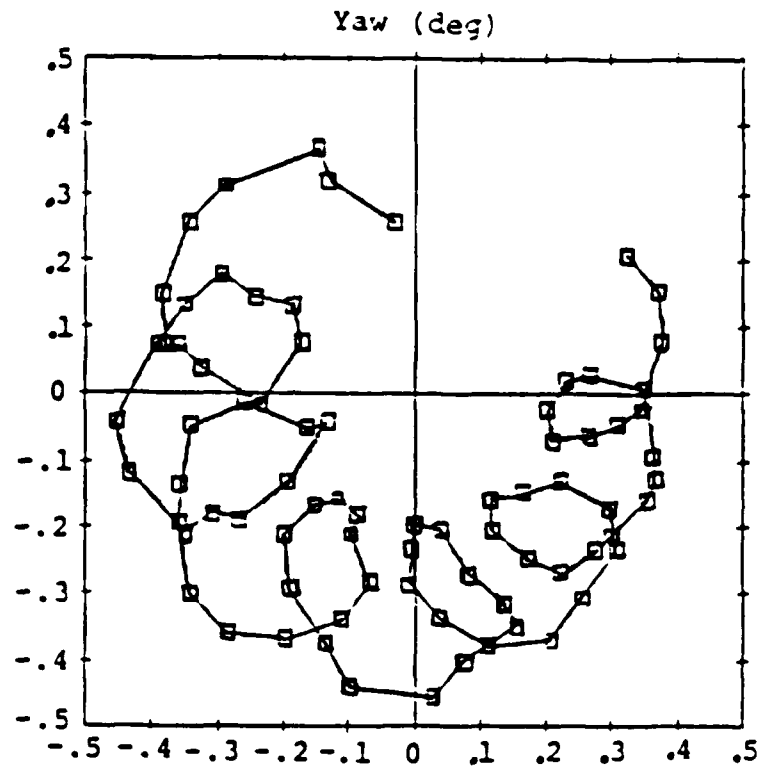
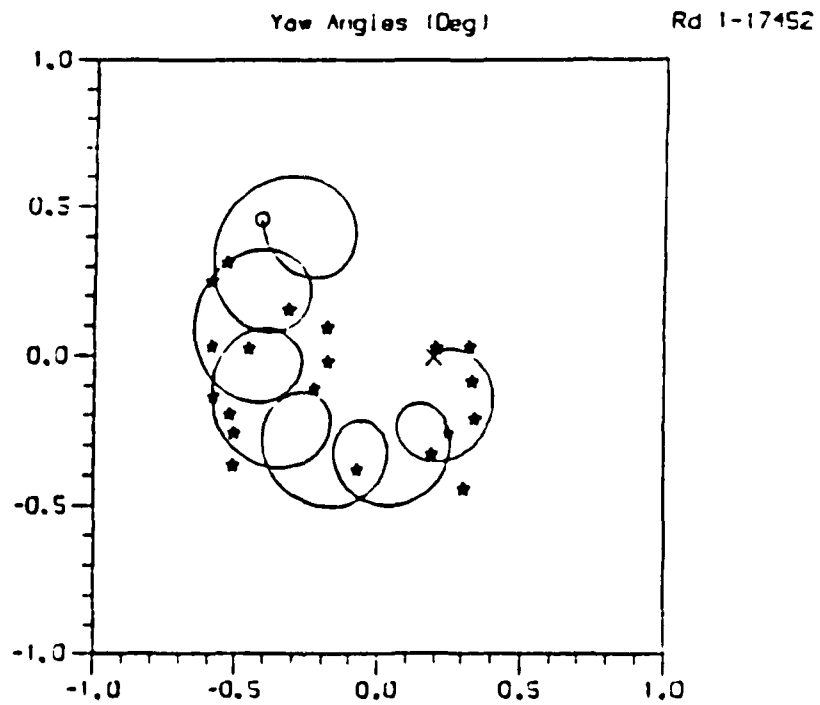

Figure 11. Total Yaw, Round 17452, Shadowgraph.



a) Laser Data



b) Shadowgraph

Figure 12. Yaw Angle, Looking Up-range, Round 17452.

Round 17453 and 17458 - No data was acquired on these rounds due to problems with the range trigger. However, the rounds were calibrated prior to each firing. The calibration technique is described below.

The round is mounted in a precision two-axis motorized optical mount. The mount has a digital encoder that is coupled to the HP-9836 computer. The initial angle is adjusted so that the Fresnel reflection from the reflector assembly returns to the laser. The projectile is rolled so that motion on one axis produces no modulation of the fringes for the orthogonal axis. The mount is then driven slowly and the fringe pattern versus encoder counts is stored in the computer. Figures 13 and 14 show typical fringe patterns. The number of counts per fringe is found by the geometric construction shown on the figure.

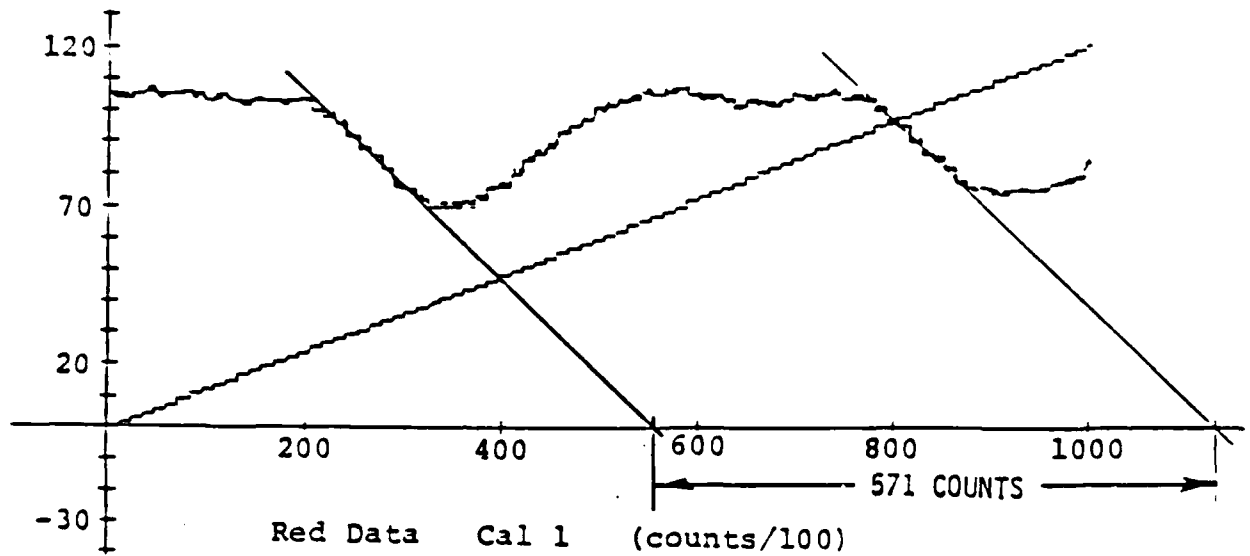

1240 COUNTS = 10^{-2} rad
 FRINGE ANGLE = 4.61 mrad (0.264 deg.)

Figure 13. Fringe Angle Calibration, Red.

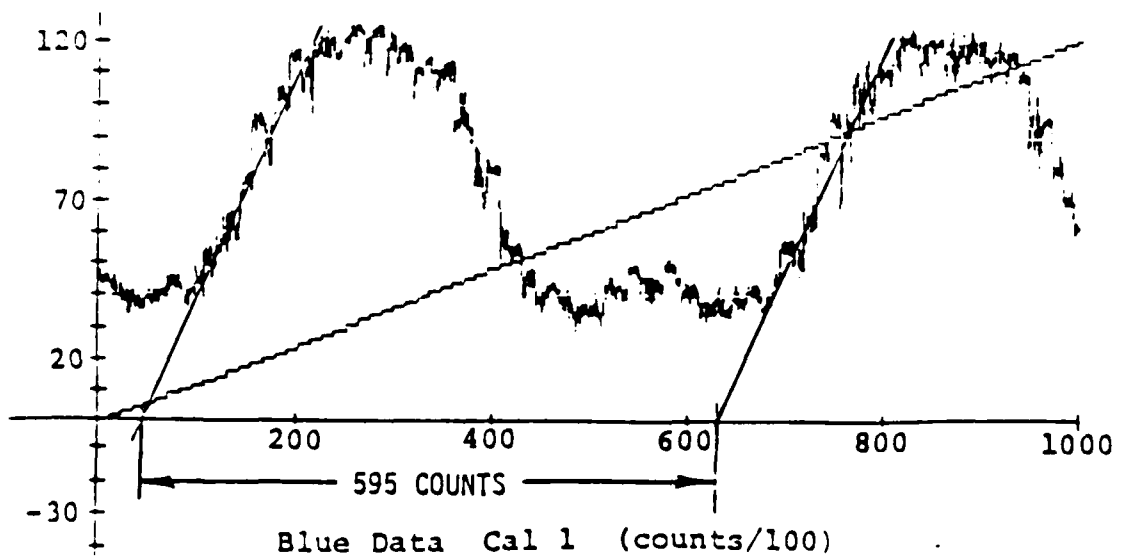

FRINGE ANGLE = 4.80 mrad (0.275 deg.)

Figure 14. Fringe Angle Calibration, Blue.

Rounds 17460 and 17462 - The purpose of these rounds was to evaluate the use of circular dither with two laser lines to measure all three angles of a non-spinning projectile. The reflector assemblies were calibrated in the precision 2-axis mount prior to firing the rounds. The hologram configuration was the orthogonal nested holographic grating as described in the preceding section. The hologram diffraction angle was one degree.

Fringe data was obtained for both of these rounds, and the signals are quite clean. Unfortunately, the rounds were very dynamic. The fringe rate is too high for processing with the algorithm that was developed on this program. The data reduction algorithm is designed for the case where the fringe rate is small compared to the dither rate. Figure 15 shows the output of the data reduction algorithm for these rounds. Figure 16 is the range data for round 17460.

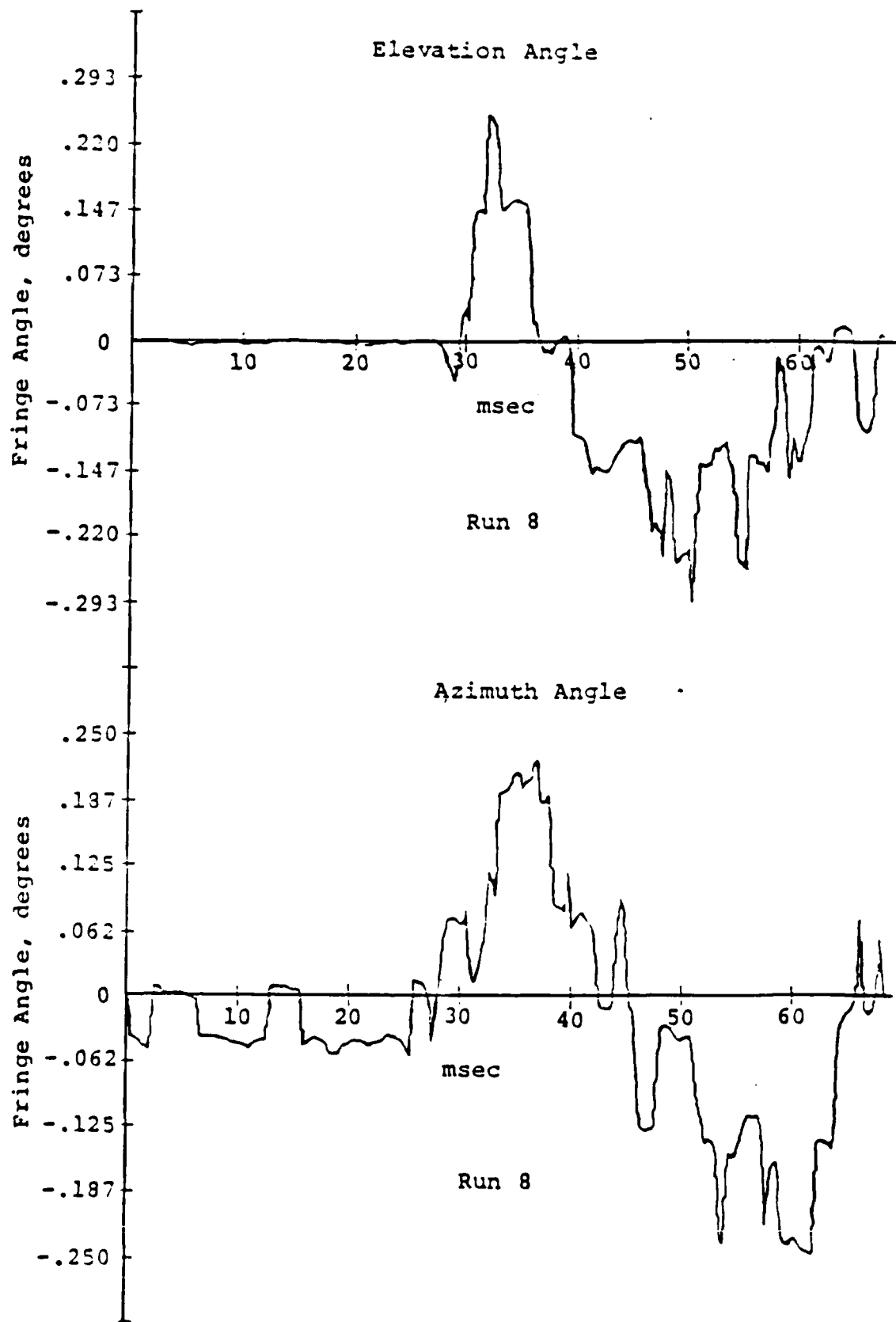
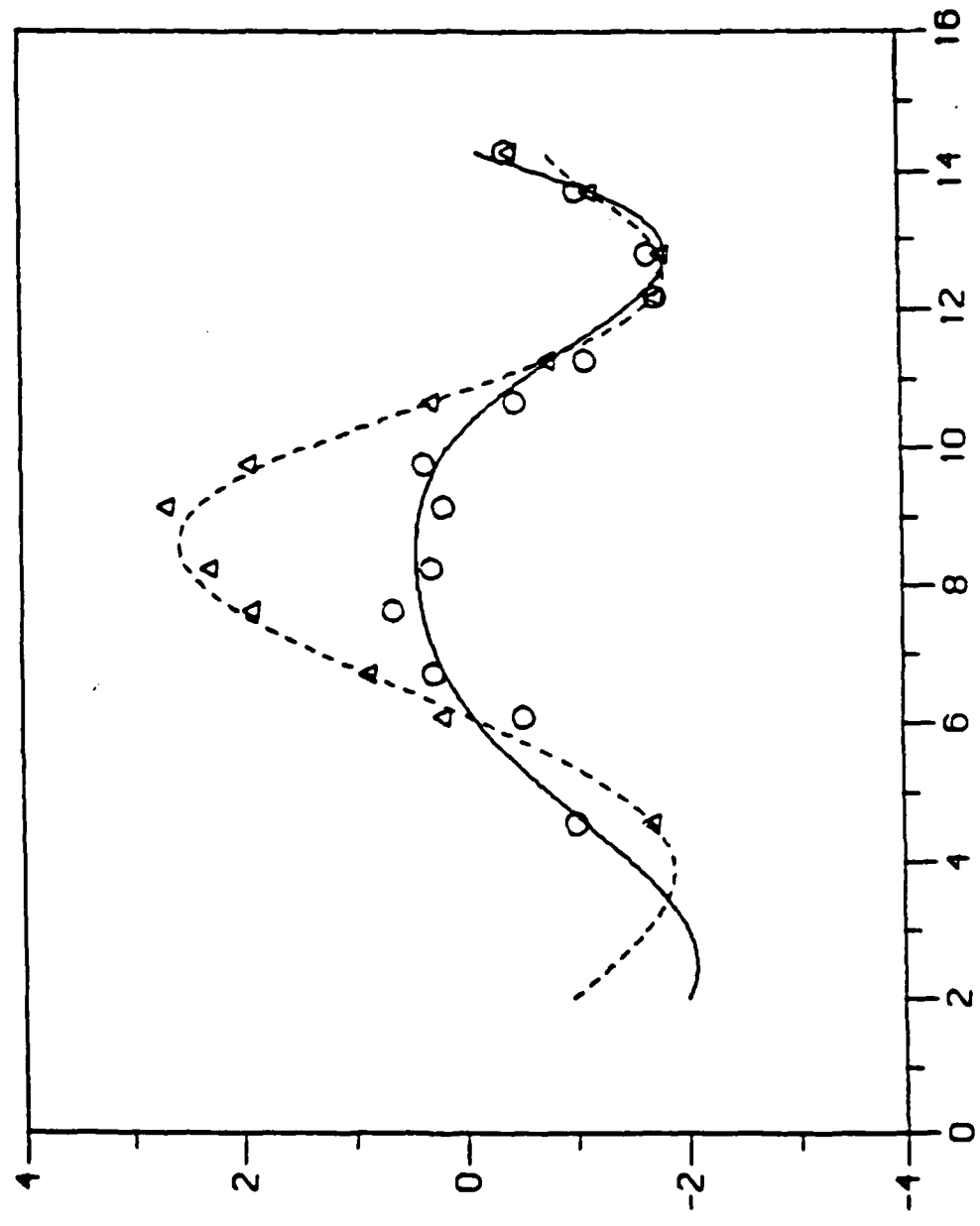

Figure 15. Computer Output, Round 17460.

Yaw Angles (Deg) vs. Z (m) Rd 1-17460



Solid: Beta, Dashed: Alpha
Figure 16. Yaw Angles versus Z, Round 17460.

Round 17464 - In-Bore. The optical unit was in the loading room. The laser beam passed through a 50 mm hole in the blast room wall and was directed by a pair of mirrors into the muzzle. The projectile base was fitted with a rubber seal in an attempt to prevent the passage of combustion gases. The seal failed, and no data was obtained from this round due to obscuration of the optical beam by leakage of hot combustion gases.

Rounds 17466 and 17467 - Muzzle Angle and Displacement. This setup is similar to the in-bore setup, except that the second folding mirror directed the laser beams to a reflector assembly mounted on a collar attached to the muzzle. In addition, the Boeing Dynamic Displacement Measurement System (DDMS) was used to measure the horizontal displacement of the muzzle.

Figures 17 and 18 are reduced angle data for these rounds. The blue laser measures the azimuth angle and the red laser measures the elevation angle.

DDMS counter output versus sample number is shown in Figure 19. Positive numbers correspond to displacement toward the right side of the range, looking down-range. The sample rate is 36 kHz.

The data for run 14, round 17466, indicates no motion for the first 5.6 milliseconds (200 samples), then a linear displacement of .280 millimeters in the following 2.5 milliseconds. The DDMS record then becomes flat, indicating that hot muzzle gases have passed through the beam. The hot gas destroys the lateral coherence of the signal beam, so the fringe count stops. The hot gas also affects the angle measurement system.

The displacement data can be used to estimate angular motion. Assume that the gun-tube bending follows a circular arc, then the angular change at the end of the tube is equal to the displacement divided by one-half the tube length. This results in an angle of 0.56 milliradian (0.032 degrees) for round 17466.

Proximity probes (used by BRL personnel following the above series of tests) registered a peak pointing angle of roughly 0.1 degree in the horizontal direction and a somewhat larger angle in the vertical direction.

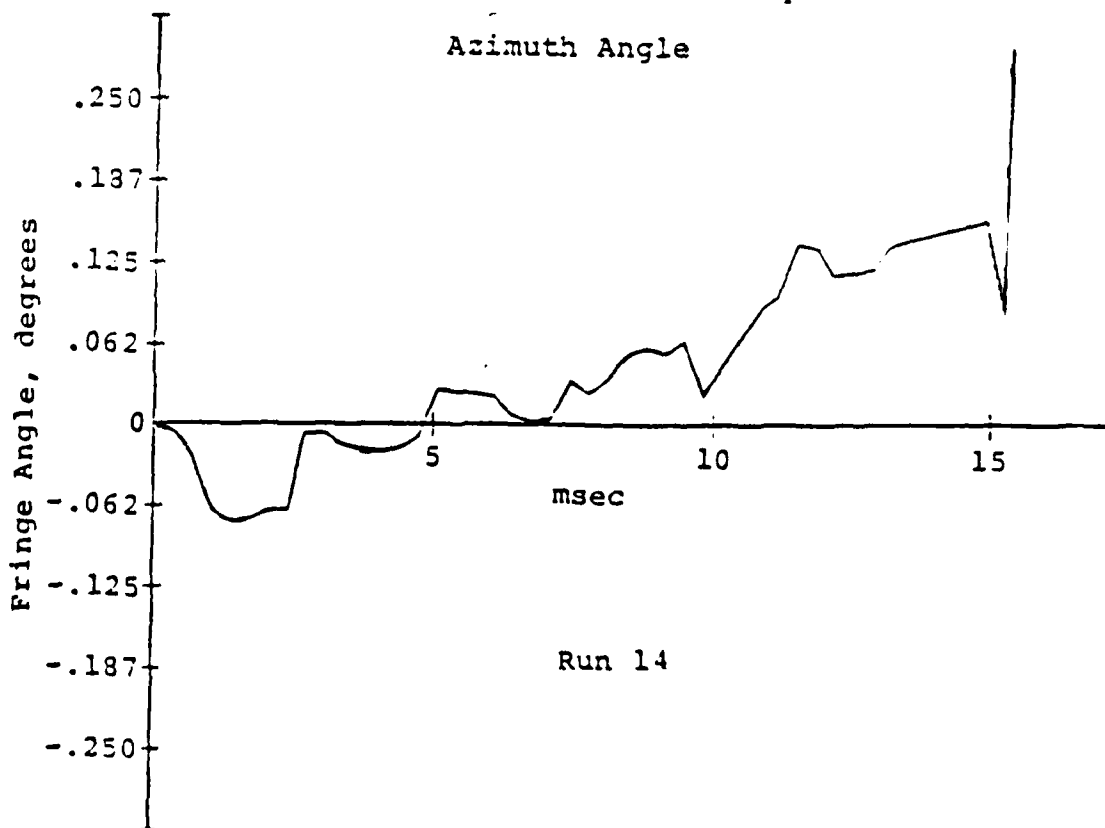
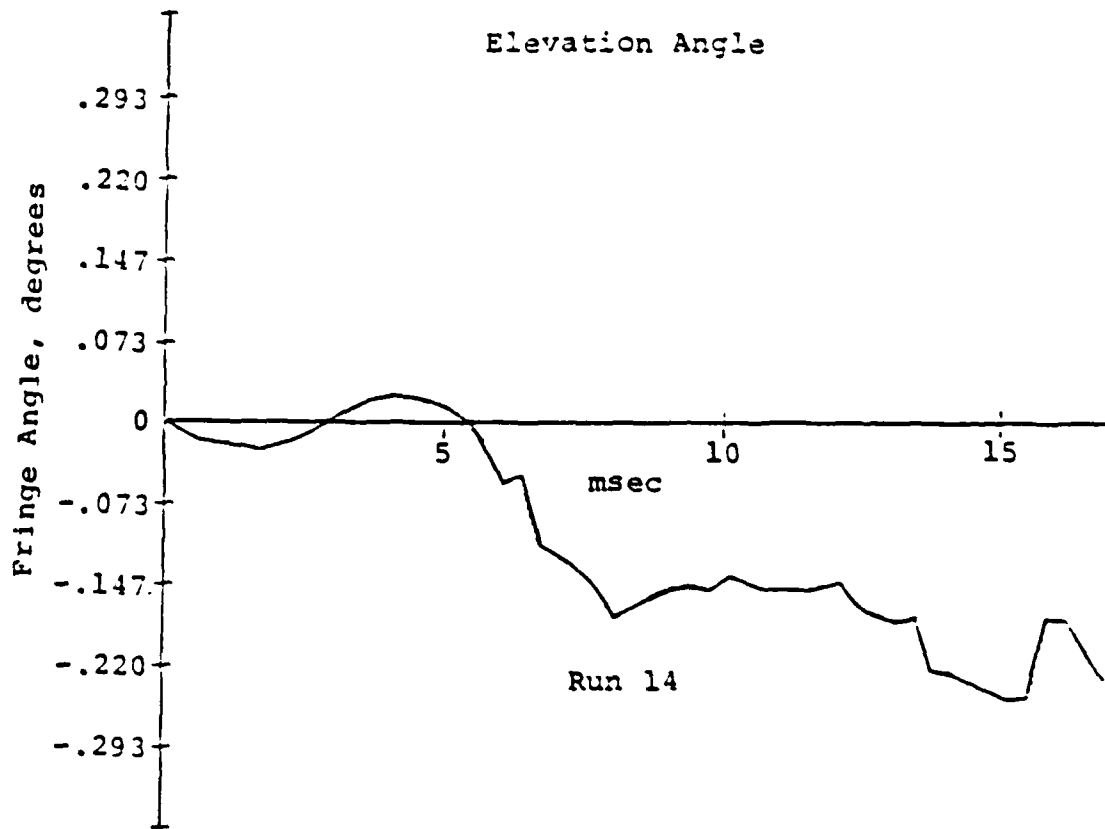

Figure 17. Muzzle Angle, Round 17466.

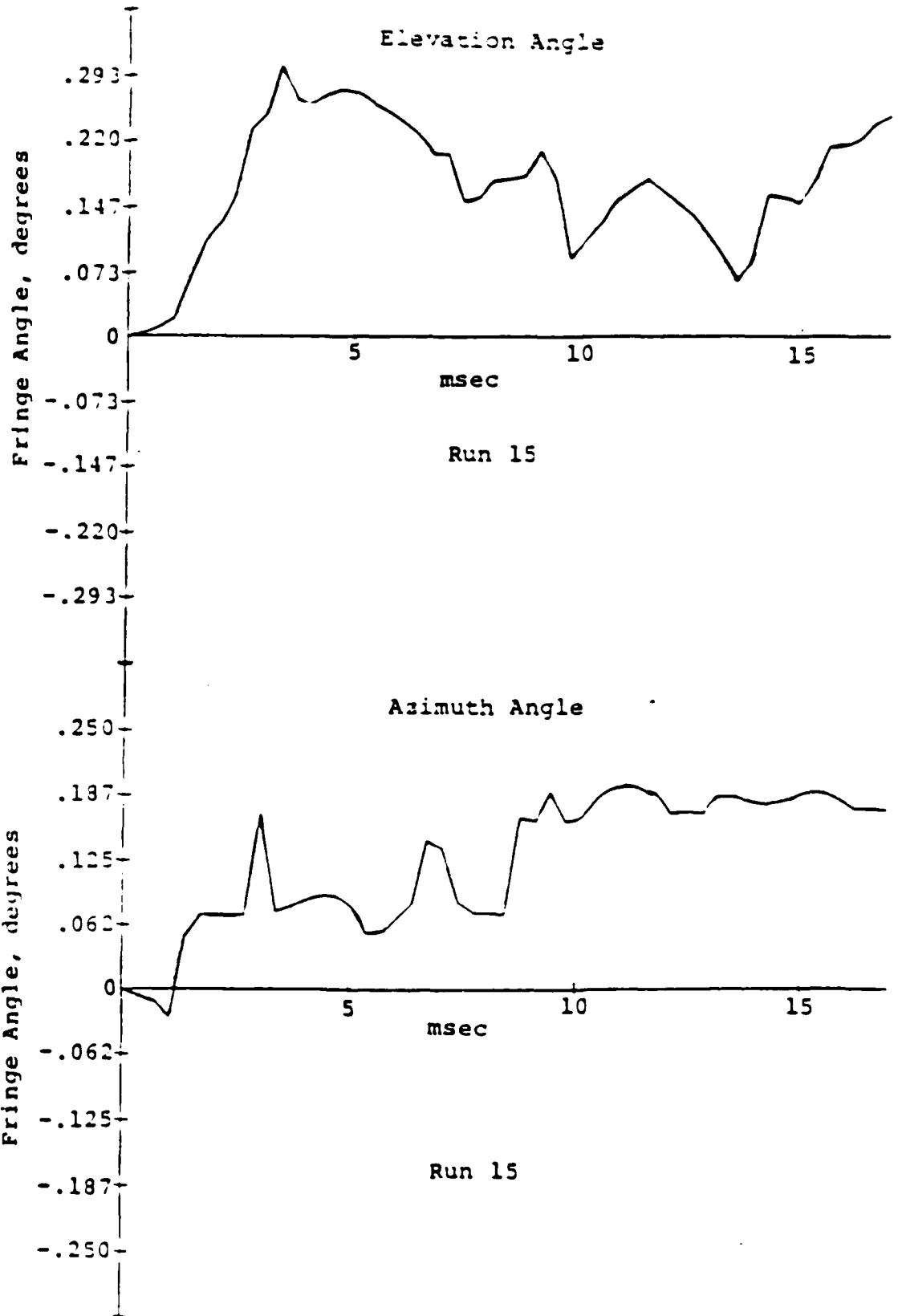

Figure 18. Muzzle Angle, Round 17467.

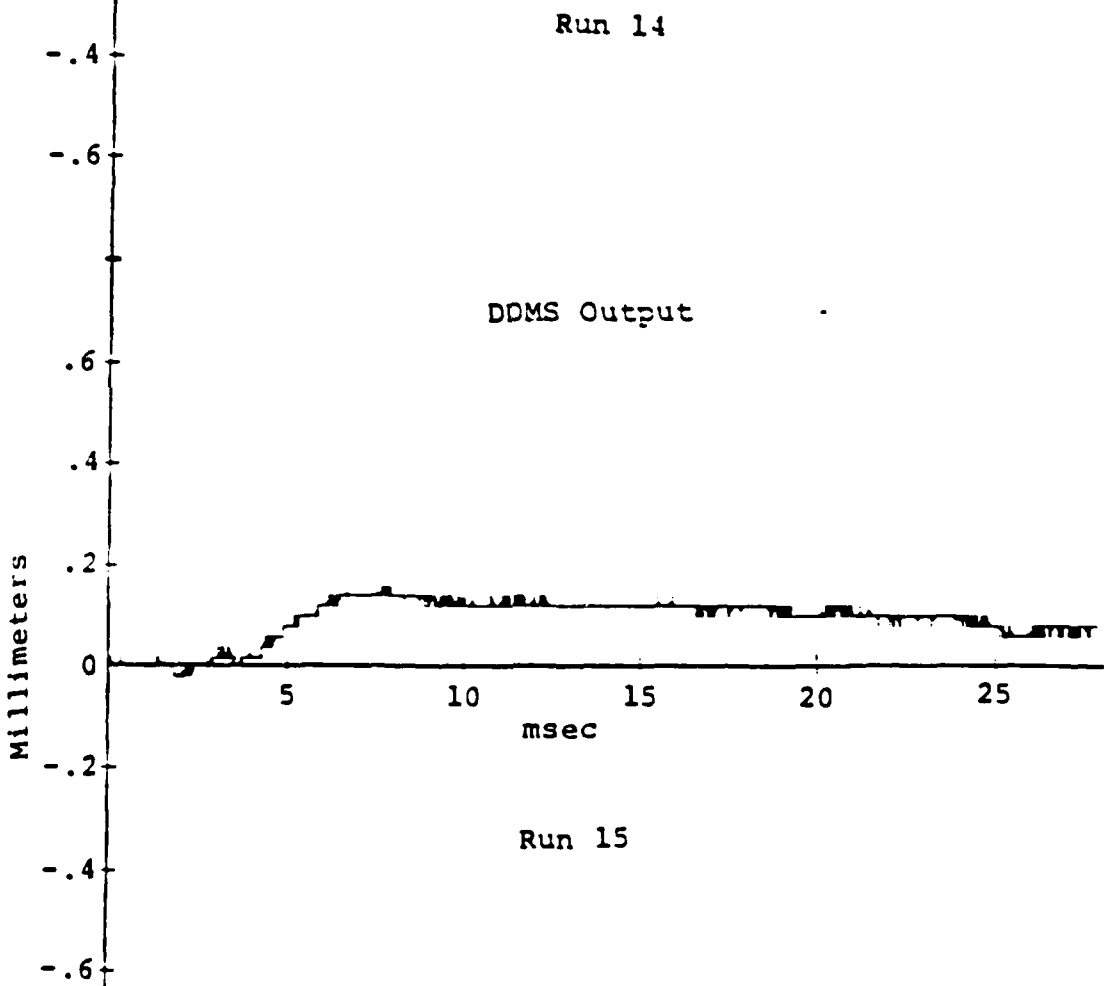
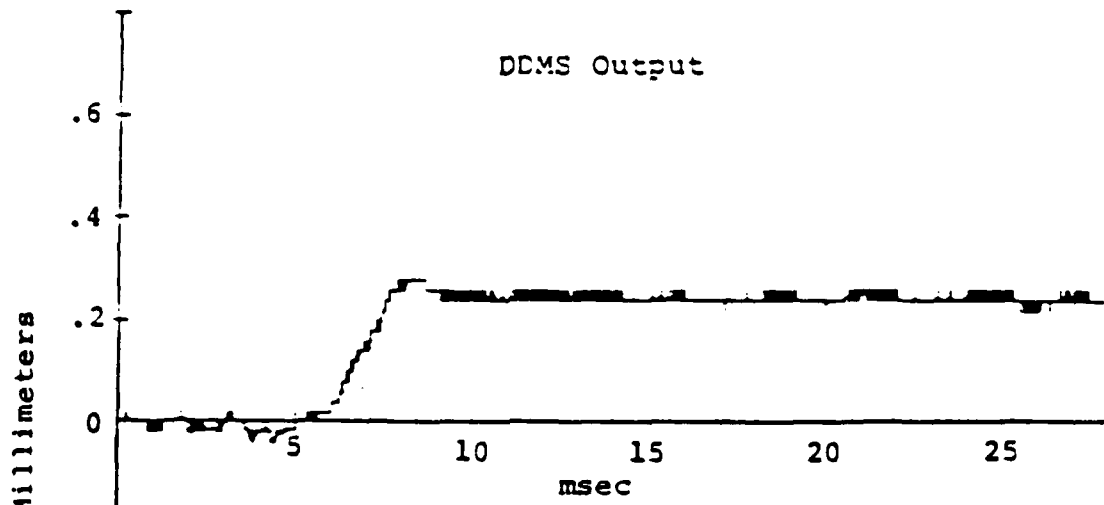

Figure 19. Muzzle Displacement, Round 17466 and 17467.

ANALYTIC MODEL

The equations relating the projectile angular motion with the output current from the photodetector will be developed in this section. The relationships for the general case (a spinning, yawing projectile observed by an optical system employing circular dither) are first derived. The simplifications that result when using a fixed laser beam or non-spinning projectile are then discussed.

A right-handed coordinate system is used in the analysis, with the X axis horizontal, the Y axis vertical and the Z axis along the range centerline. The optical centerline also coincides with the Z axis. The projectile undergoes pitching and yawing motions as a function of time, so the orientation of a projectile based coordinate system (x, y, z) may be specified by the direction cosines $(\cos\alpha_p, \cos\beta_p)$ as shown in Figure 20-a.

The intensity of light reflected by the holographic grating/retroreflector combination placed at the nose of the projectile is a function of the angular orientation of the input laser beam relative to an axis normal to the hologram (Reference 1). It is therefore convenient to express the orientation of the body in terms of the angular coordinates

$$(u_p, v_p) = (\cos\alpha_p, \cos\beta_p)$$

where u_p and v_p may be thought of as the pitch and yaw of the projectile. The angles are chosen so that u_p is oriented perpendicular to the hologram grating lines (i.e. parallel to the direction in which light is diffracted). If the input angle is small, the reflection coefficient, $R[u_p(t)]$ is approximately a periodic function of the input angle as shown in Figure 20-b.

As part of the optical system, circular dither will be imparted to the laser light. Thus at any instant of time the angle between a ray representing the portion of the laser beam striking the retroreflector and the coordinate axes can be defined by the angular coordinates

$$(u_1, v_1) = (\cos\alpha_1, \cos\beta_1)$$

where α_1 and β_1 are the angles between the incident light and the X and Y axes respectively. Employing a trigonometric identity, the angle between the laser beam (or the body axis) and the Z axis may be expressed as

$$\gamma = \cos^{-1}(1 - \cos^2\alpha - \cos^2\beta)^{1/2}$$

Figure 20-c illustrates the optical and projectile coordinate systems. The axes u_1 and v_1 are centered on the

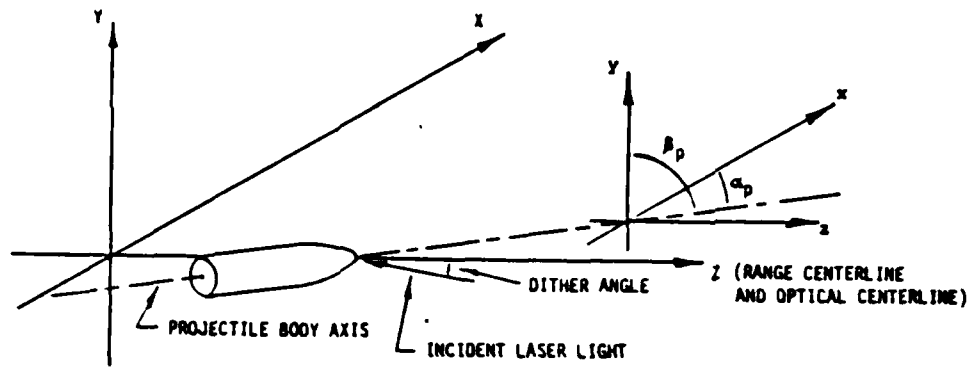

a) Projectile Geometry

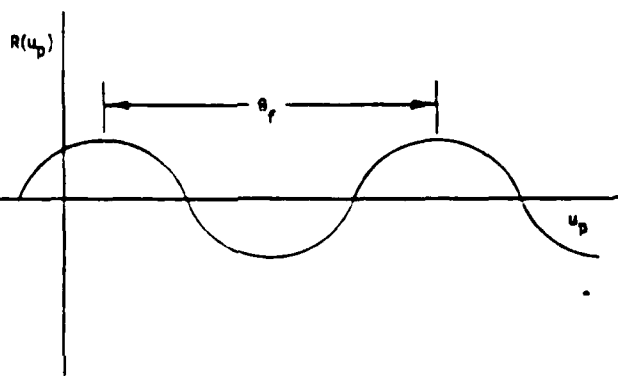

b) Reflector Reflection Coefficient versus Angle

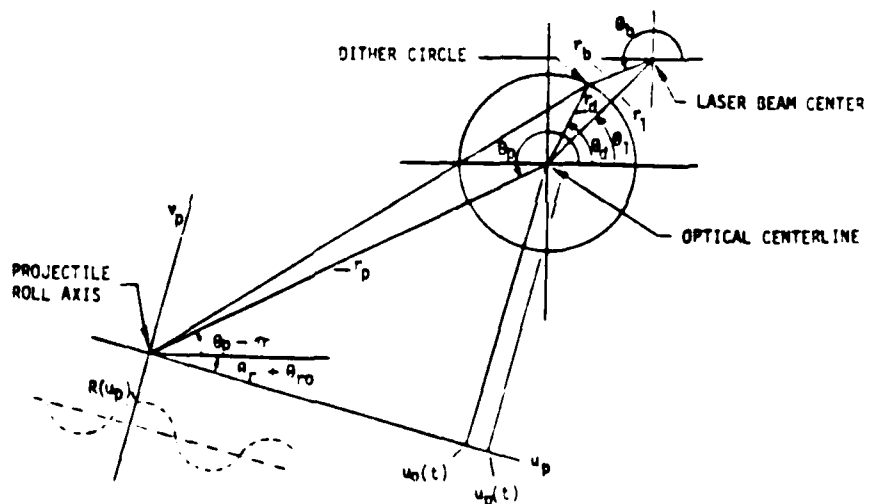

c) Angular Geometry of Projectile and Laser Beam

Figure 20. Analytic Model Geometry.

optical centerline with u_1 horizontal. The body fixed projectile axes, u_p and v_p , rotate as the projectile rolls. The circle represents a circular dither of the laser beam. The polar coordinates of the center of the laser beam are (r_1, θ_1) .

The circular dither can be resolved into time varying components in the projectile coordinate system

$$u_p(t) = r \cos(\omega_d t - \omega_r t + \theta_{d0} - \theta_{r0}) + u_0(t)$$

$$v_p(t) = r \sin(\omega_d t - \omega_r t + \theta_{d0} - \theta_{r0}) + u_0(t)$$

where r = angular radius of the circular dither
 ω_d = dither angular frequency
 ω_r = roll angular frequency
 θ_{d0} = initial dither angle
 θ_{r0} = initial roll angle
 $u_0(t), v_0(t)$ = position of optical axis in projectile coordinates.

The component of the dither in the u_p direction (perpendicular to the holographic grating lines) produces a modulated output, while the component in the v_p direction (parallel to the grating lines) does not.

The detector current is the product of two time varying functions. Since the intensity of the laser is not spatially uniform, as the beam is swept across the reflector (due either to the dither or the motion of the projectile) the light entering the retroreflector is amplitude modulated. The reflector further modulates the beam because the reflection coefficient, $R[u_p(t)]$, varies with the angle of incidence.

If it is initially assumed that the laser beam profile is not a function of z , then the intensity may be represented by

$$I(t) = (r_b, \theta_b)$$

where $r_b = (r_d^2 + r_1^2 - 2r_d r_1 \cos(\theta_{d0} + \omega_d t - \theta_1))^{1/2}$

$$\theta_b = \cos^{-1}[(r_d^2 - r_b^2 - r_1^2)/2r_b r_1]$$

The circular dither is actually a conical scan with a fixed point at a distance z from the initial projectile position. The linear displacement of the beam with respect to the retroreflector is a function of $z - z_0$ (when $z = z_0$ there is no translation of the beam). The z axis dependence can be placed into the expression for $I(t)$ by replacing r_1 with $r_1(t)$, where

$$r_1(t) = r_1(0) \cdot (z_0 - z(t))/z_0$$

The photodetector current is therefore

$$i(t) = \rho \Gamma I(t) R[u_p(t)]$$

where ρ = detector responsivity (amp/watt)
 Γ = optical efficiency
 I = laser beam intensity

Two special cases will be considered, both assuming that the laser beam is uniform, so that $I(t)$ is constant.

(1) The retroreflector reflection coefficient is a pure sinusoid with period θ_f .

(2) The reflection coefficient is periodic, but has higher order components.

Case 1: $R[u_p(t)] = a + b \sin(2\pi u_p(t)/\theta_f - c)$

where a = average value
 b = amplitude
 θ_f = angle between fringes
 c = phase at $t=0$

$$u_p(t) = r_d \cos(\omega_d t - \omega_r t + \theta_{d0} - \theta_{r0}) + u_o(t)$$

Let $d = \rho \Gamma I$, $k = 2\pi/\theta_f$ and $w = \omega_d t - \omega_r t + \theta_{d0} - \theta_{r0}$
then the detector current is

$$i(t) = ad + bd \sin[kr_d \cos w + k u_o(t) - c]$$

Express the sine term as a sum to get

$$i(t) = ad + bd \sin(kr_d \cos w) \cos(k u_o(t) - c) + bd \cos(kr_d \cos w) \sin(k u_o(t) - c)$$

We can then expand the terms with sinusoidal argument using the Bessel function identities

$$\sin(z \cos \theta) = 2J_1(z) \cos \theta - 2J_3(z) \cos 3\theta + \dots$$

$$\cos(z \cos \theta) = J_0(z) - 2J_2(z) \cos 2\theta + 2J_4(z) \cos 4\theta - \dots$$

The first few terms are

$$i(t) = ad + bd J_0(kr_d) \sin(k u_o(t) - c) + 2bd J_1(kr_d) \cos w \cos(k u_o(t) - c) - 2bd J_2(kr_d) \cos 2w \sin(k u_o(t) - c) + 2bd J_3(kr_d) \cos 3w \cos(k u_o(t) - c) + \dots$$

These harmonic components can be separated by filtering, then bidirectional changes in $u_0(t)$ can be determined by tracking the coefficients of $\cos [ku_0(t)]$ and $\sin [ku_0(t)]$ for a pair of even and odd harmonics. Note that the harmonic frequencies are multiples of the difference between the dither and roll frequencies. If the dither is high compared to the roll rate, roll produces a slow change in the phase of the dither.

Case 2: $R(u)$ is periodic but not a sinusoid.

The projectile reflector must be calibrated before firing. During calibration, $R(u)$ is measured over at least one period of θ_r . If the dither is on, the amplitudes of two adjacent harmonics are stored in a look-up table of harmonic amplitudes versus angle. If the dither is off, the table entries can be calculated as follows:

Write $R(u)$ as a Fourier series

$$R(u) = a_0/2 + a_1 \cos(ku) + a_2 \cos(2ku) + \dots \\ + b_1 \sin(ku) + b_2 \sin(2ku) + \dots$$

Replace u with $u + r_d \cos(w)$, then expand each term using the Bessel function identities and collect like harmonics. The first few terms of the expansion and rearrangement are:

$$R_0(u) = a_0/2 + \sum_{j=1}^m [a_j \cos(jku) + b_j \sin(jku)] J_0(jkr_d)$$

$$R_1(u) = 2 \cos w \sum_{j=1}^m [a_j \sin(jku) - b_j \cos(jku)] J_1(jkr_d)$$

$$R_2(u) = 2 \cos 2w \sum_{j=1}^m [a_j \cos(jku) + b_j \sin(jku)] J_2(jkr_d)$$

$$R_3(u) = 2 \cos 3w \sum_{j=1}^m [a_j \sin(jku) - b_j \cos(jku)] J_3(jkr_d)$$

These are the harmonic amplitudes for the look-up table. The table is used to reduce the data after the round is fired.

The data is reduced in increments of the dither minus roll period. For each increment, harmonic component amplitudes can be found with the digital filtering routine in the data reduction algorithm. The look-up table is used to find the fractional angle u , where $u \leq \theta_r$. The total angle is incremented or decremented by θ_r each time u moves through the table.

PRELIMINARY DESIGN

This section contains preliminary design information for a three angle measurement system. The design addresses the limitations of the breadboard system tested at BRL, and defines the areas which require further development before a final design can be implemented.

The major limitation of the breadboard system was the dither rate. An available galvanometer deflection system was used to generate a conical scan at 3 KHz. However, in many cases the fringe rate was comparable to the dither rate. The dither rate must be much higher than the fringe rate, otherwise, the desired effect of the dither modulation is destroyed and angle information cannot be recovered. Spin stabilized rounds with fringe rates of 30 KHz have been observed in our test program. A dither rate of the order of 1 MHz would be appropriate. Oscillating mirrors (galvanometer type of resonant scanners) have a capability up to 20 KHz. Polygonal mirrors on turbine motors can generate higher scan rates, but produce linear rather than conical scans. The mechanical limit (reference 3) for a polygonal mirror is:

$$w = \frac{1}{2\pi r_0} \sqrt{\frac{8UTS}{p(3+n)}}$$

- where r_0 = Distance from center to edge
UTS = Ultimate tensile strength
 n = Poisson's ratio of material
 p = Volumetric density

Substituting the values for 6061 T6 aluminum, the mechanical limit for a 5 cm diameter scanner is about 10^4 revolutions/second. If the mirror had 20 facets, the scan rate would be 200 KHz. The practical limit, due to mirror deformation and safety, is well below the mechanical limit.

Acousto-optic beam deflectors (AOD) are an alternative method for generating a conical scan. Two-axis devices are available, so a circular dither is possible. The limit is set by the transit time of a sound wave across the aperture of the device. The transit time is the amount of time required to move the deflected beam from one position to another. Typical values for commercial deflectors are of the order of 10 microseconds. In the breadboard system the return beam was sampled at 12 positions around the dither circle. If an AOD is used with 10 microsecond transit time to sequentially deflect the beam to 12 points on a circular arc, the maximum rate would be 8.51 KHz. This rate is also inadequate for a spinning projectile.

A solution to the high dither rate requirement is to use a circular array of diode laser beams, where the diode lasers are sequentially modulated to produce a rotating optical source. Very high dither frequencies are possible with this technique. (We are currently modulating a Mitsubishi model ML 3001 diode laser at a frequency of 1 GHz.) The wavelength of laser-diodes are temperature sensitive. Diode lasers are available with fiber optic pigtails, so the lasers can be mounted on a temperature controlled heat sink and the fibers led out to form a circular array in the focal plane of the collimating lens. Two color operation is accomplished by selecting lasers so the even and odd fibers radiate in different wavelength bands, such as $830 \pm 5\text{nm}$ and $850 \pm 5\text{nm}$.

Figure 21 shows two optical configurations. Both configurations show an off-axis paraboloid mirror for collimating the beam. The beam diameter would be of the order of 30 cm, so the refracting optics as used in this program become more expensive than off-axis optics. Furthermore, the Fresnel reflection from the center of a refractor is avoided with reflecting optics.

Figure 21a is a three-axis system for measurements of spinning projectiles, using techniques verified on this program. The concept shown in Figure 21b is a circular dither system using diode laser, as described above. The first technique is lower risk and cost, since all the techniques have been demonstrated in this program.

PHASE II PROGRAM

The major task in Phase II is the design and fabrication of a three-component angular measurement system. The results of the Phase I test program made a significant impact on the requirements for the Phase II system. The major requirement is for a much higher dither rate in order to follow the dynamics of some of the projectiles. Other requirements are increased laser beam diameter, improvements in the data reduction algorithms, and increased stability of the holograms in the humid environment at BRL. The Phase II tasks are listed below:

- 1) Design and fabricate a three-component angular measurement system. Two variations of the three-component system are possible.
 - a. Total yaw system for spinning projectiles. This technique was demonstrated on the prior contract, and improved to measure all three angles in the present contract.
 - b. Three-component system with circular dither for both spinning and non-spinning projectiles. The technical difficulties are greater and the risks are higher for this system. At this time it appears that the only method for generating the required high dither rate is to use a circular array of optical fibers, each driven by a diode laser, where the relative phases of the diode lasers is adjusted to produce a conical scan. The dither generation technique should be thoroughly evaluated with a breadboard device prior to fabrication of the three-component system.
- 2) Data reduction algorithms
 - a. No computer data reduction algorithm has been developed for 1a. Such a system would require the development of a suitable algorithm.
 - b. The algorithm for 1b has partially been developed in Phase I. Additional development is required based on the results of Phase I and the analytic model developed in Phase I. One of the important problems to be addressed is the magnitude of error caused by the deviation of the reflector reflection coefficient from a sinusoid. The algorithm already developed is for the sinusoidal case, but the reflection coefficient is approximately sinusoidal only when the diffraction efficiency is low. In order to maximize the return power, it is necessary to operate with a reflection coefficient versus angle that departs significantly from a sinusoid.

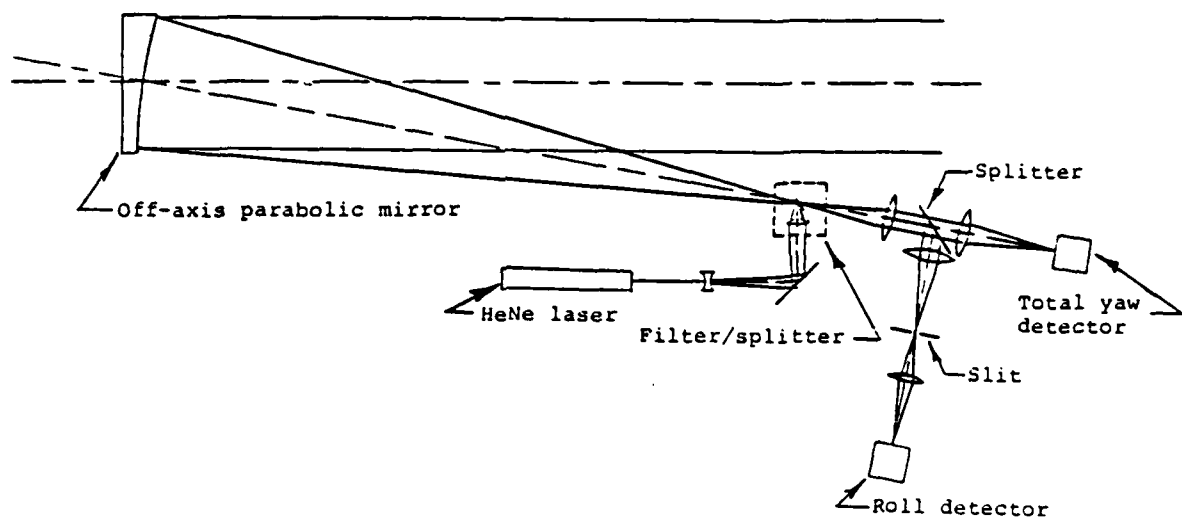

a) Fixed Beam Optics

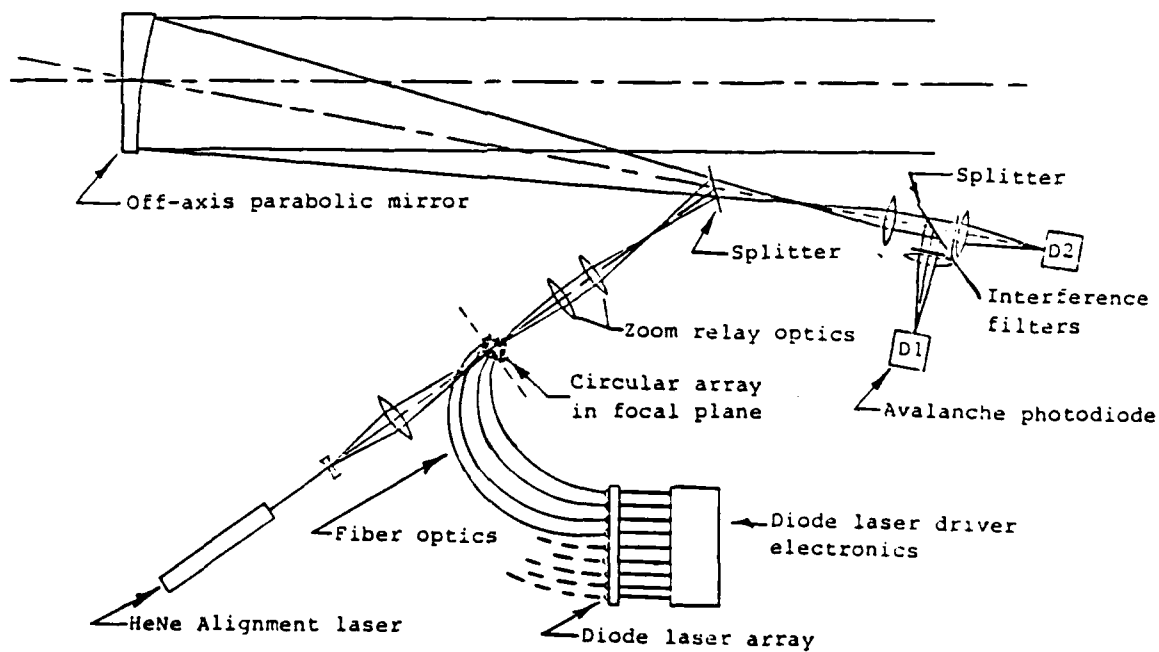

b) High Speed Circular Dither Optics

Figure 21. Laser Ballistic Sensor Configuration

c. Algorithm development would be a joint Boeing and BRL task.

- 3) Investigate techniques to stabilize the holograms after fabrication. The diffraction efficiency of the holograms changed with time due to the change in relative humidity at BRL. Some of the holograms became cloudy and unusable.
- 4) For the system of 1b, design and fabricate signal conditioning, timing, and computer interface circuitry for an acceptable dither frequency in the range of one megahertz.

APPENDIX A

ELECTRONIC SCHEMATICS

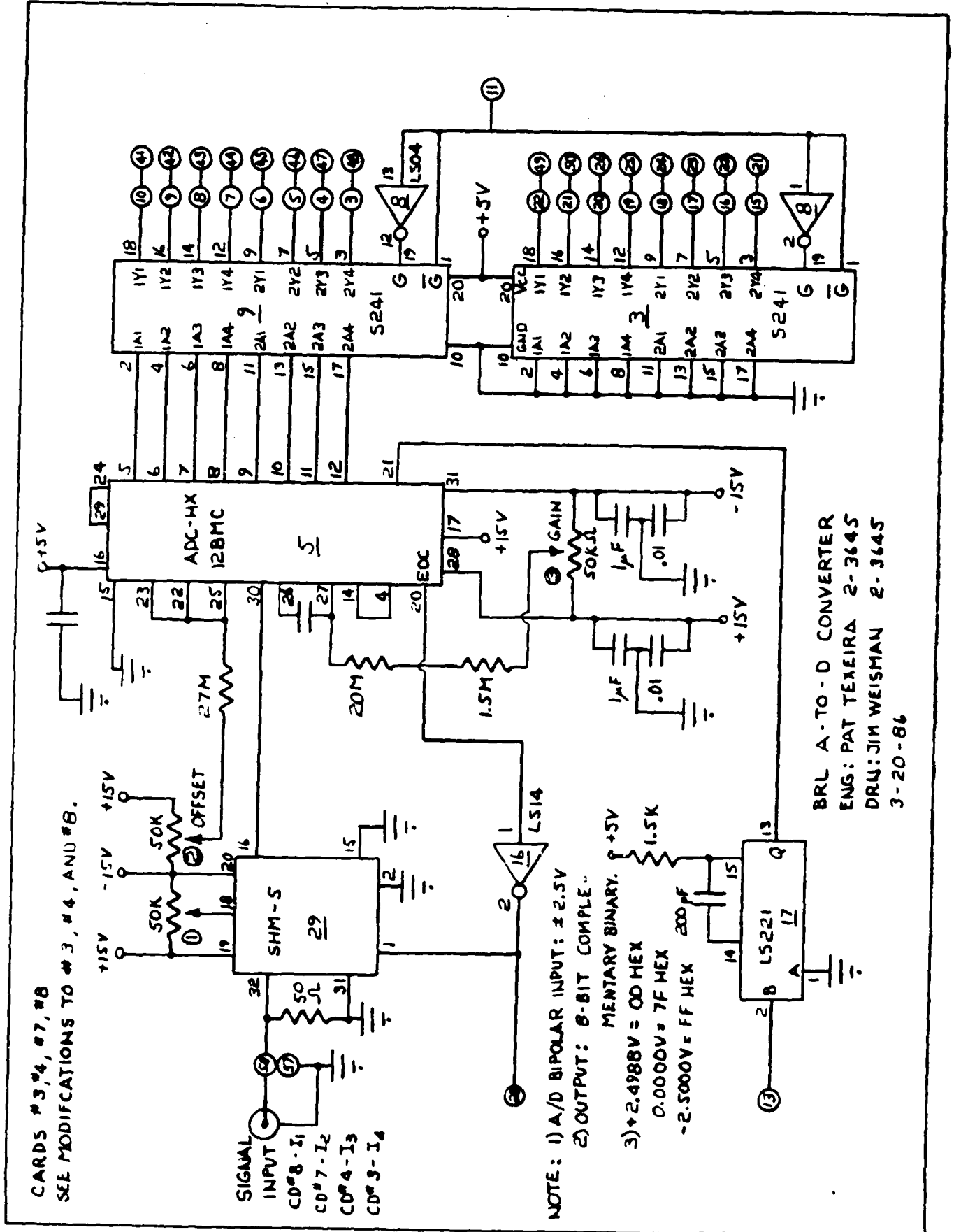

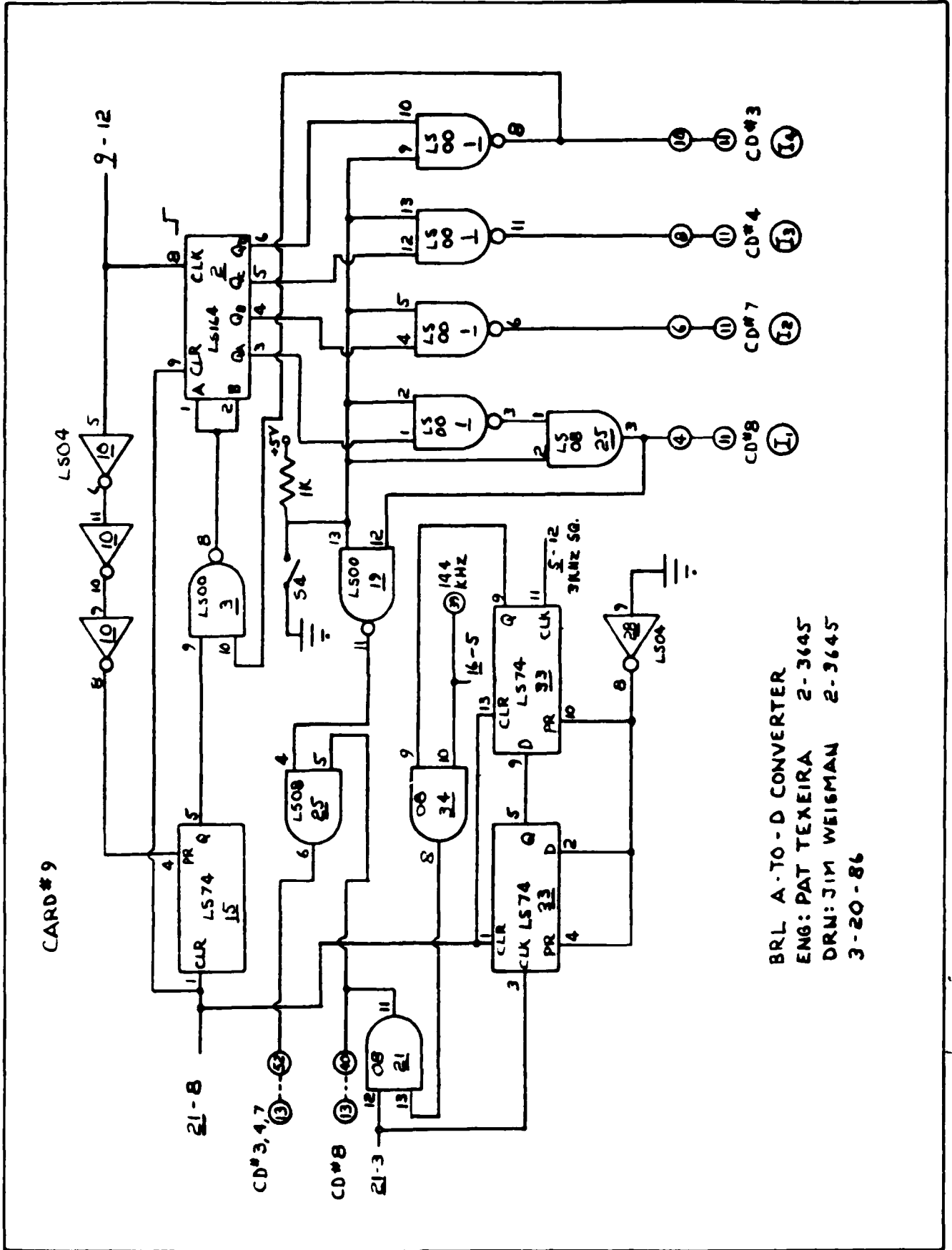

CARD #9

BRL A-TO-D CONVERTER
 ENG: PAT TEXEIRA 2-3645
 DRN: JIM WEIGMAN 2-3645
 3-20-86

CARD #9

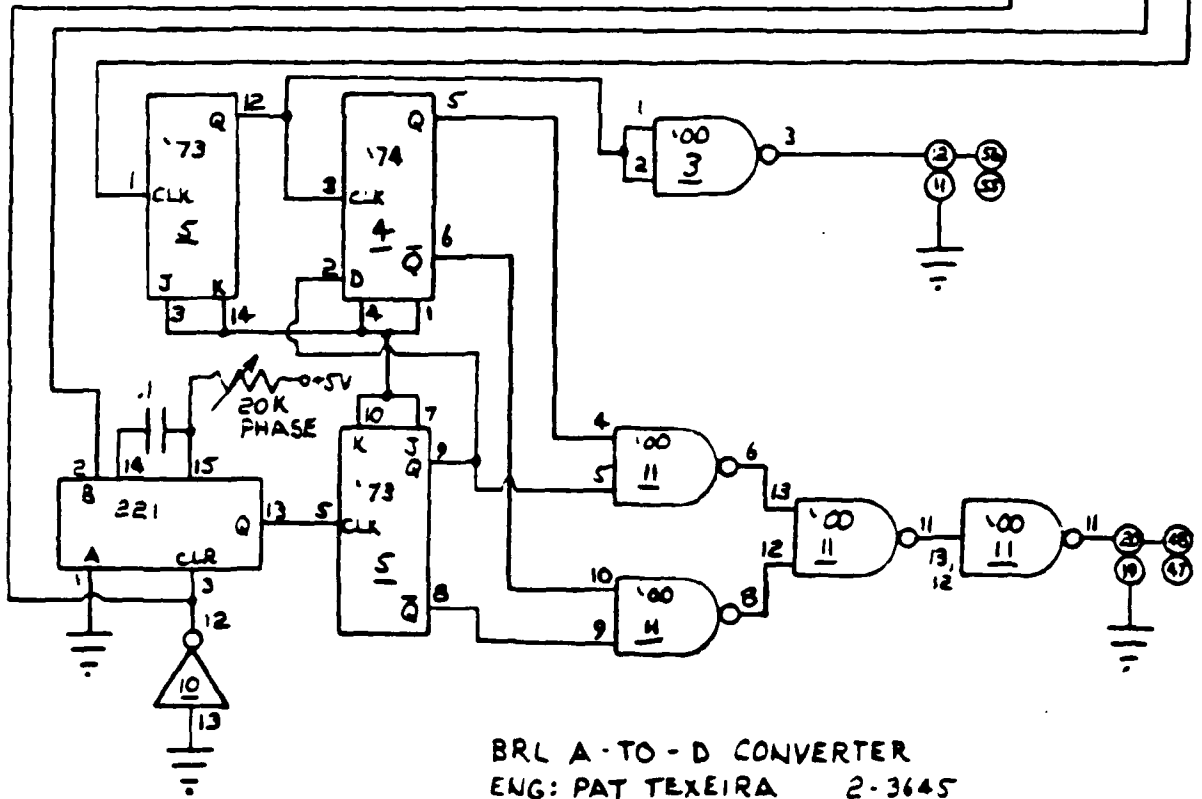
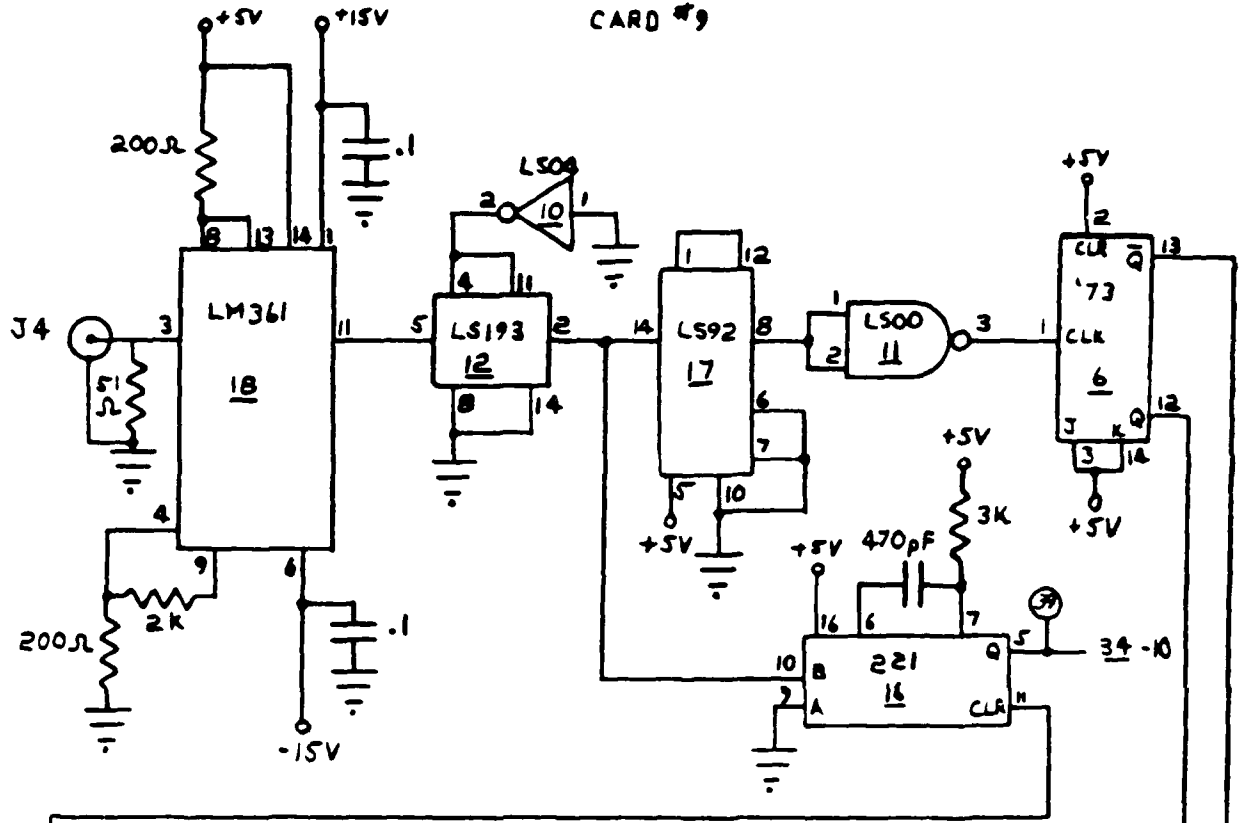

BRL A-TO-D CONVERTER
 ENG: PAT TEXEIRA 2-3645
 DRN: JIM WEISMAN 2-3645
 3-20-86

SHEET 3 OF 8

CARD # 9
3KHz - 5KHz BANDPASS FILTER
2 CHANNELS

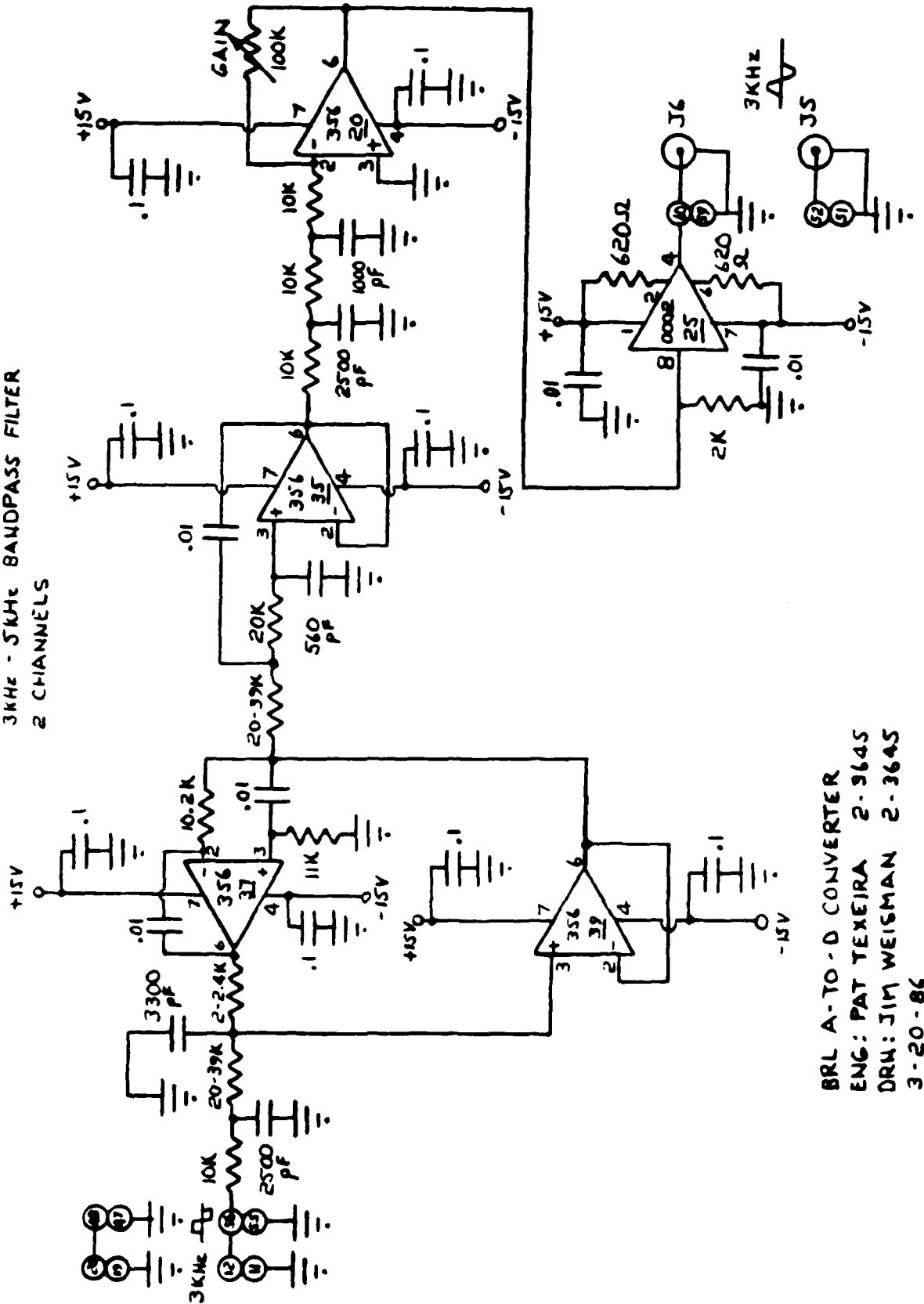

BRL A-TO-D CONVERTER
ENG: PAT TEXEIRA 2-3645
DRW: JIM WEISMAN 2-3645
3-20-86

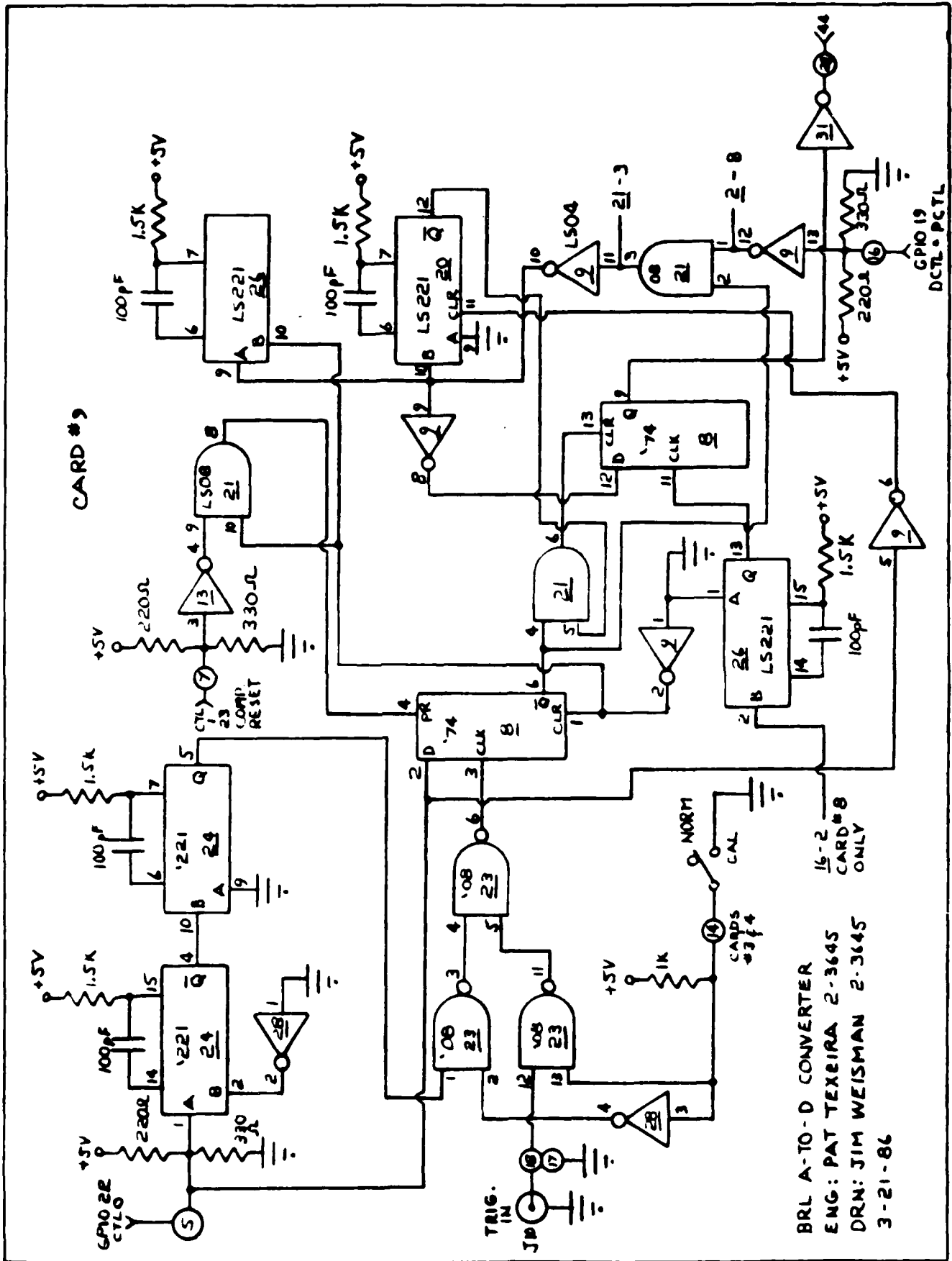

BRL A-TO-D CONVERTER
 ENG: PAT TEXEIRA 2-3645
 DRN: JIM WEISMAN 2-3645
 3-21-86

CARD # 9

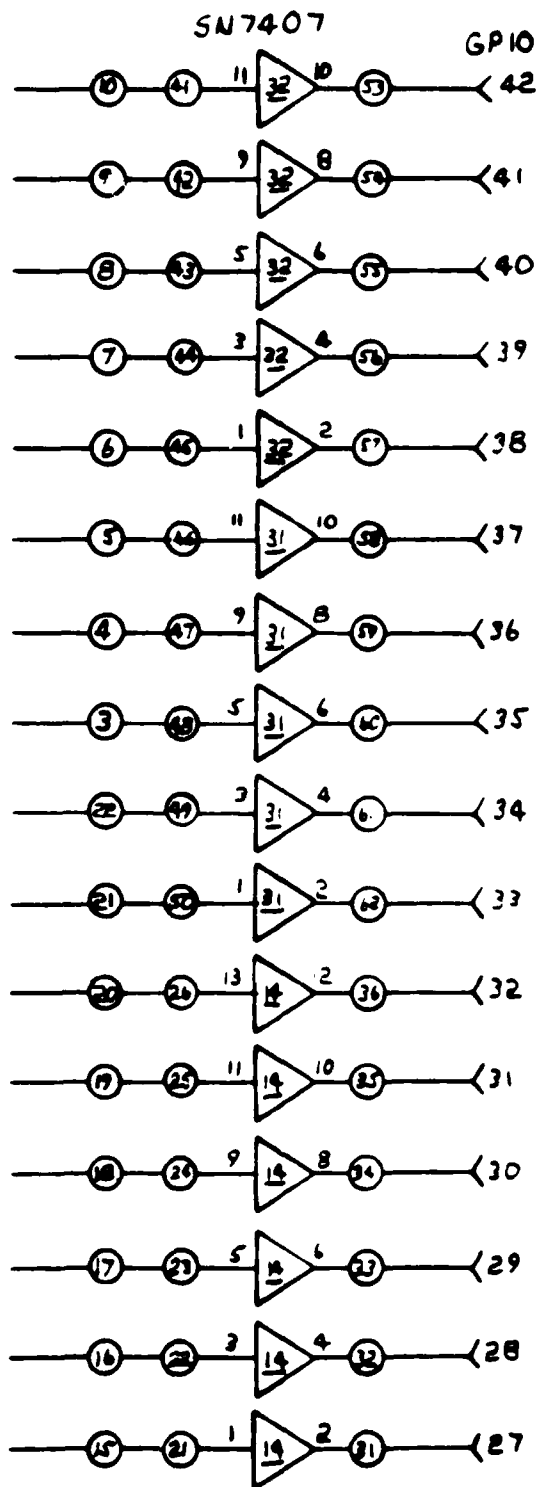

BRL A-TO-D CONVERTER
 EUG: PAT TEIXEIRA 2-3645
 DRN: JIM WEIGMAN 2-3645
 3-21-86

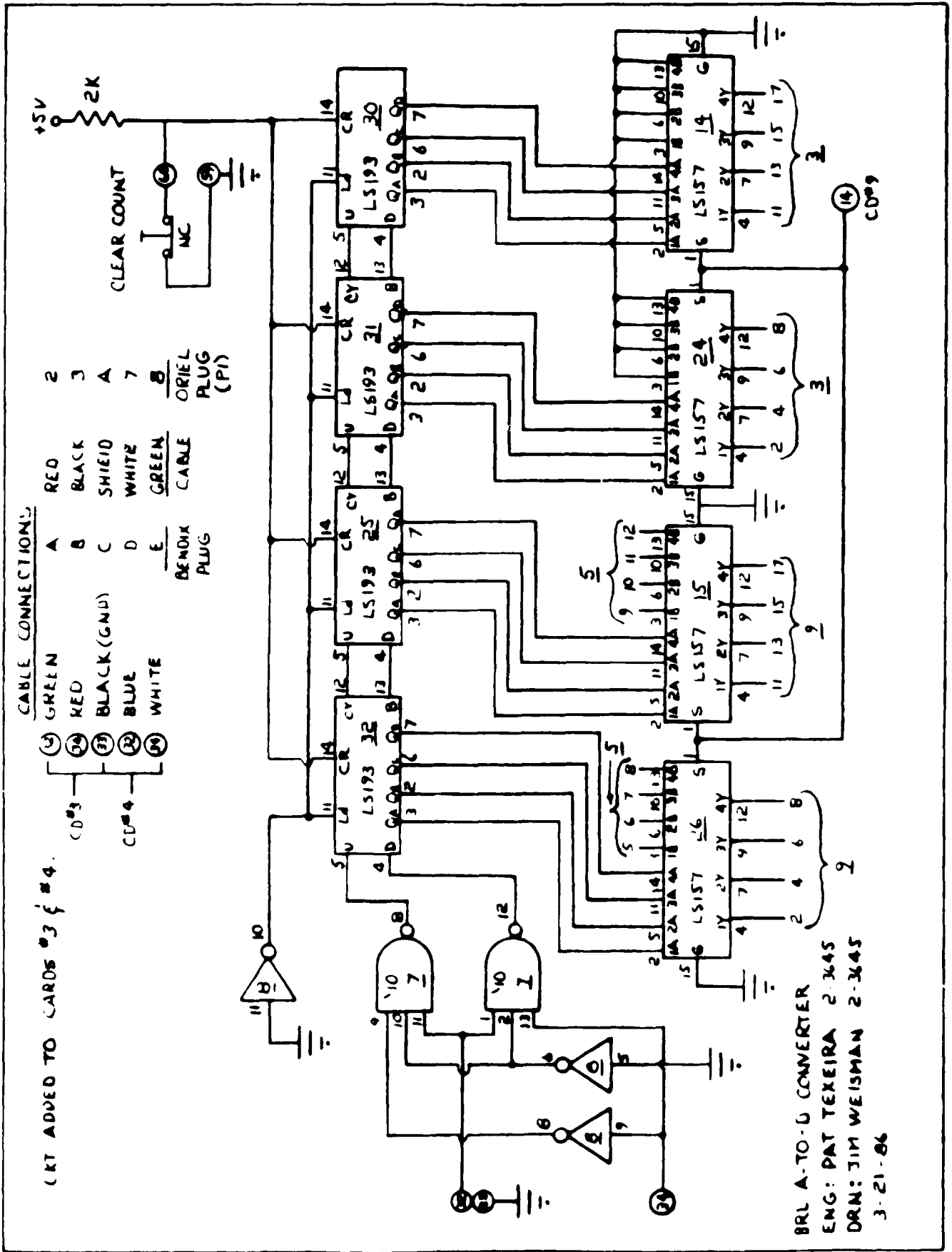

MODIFICATION OF CARD # 8

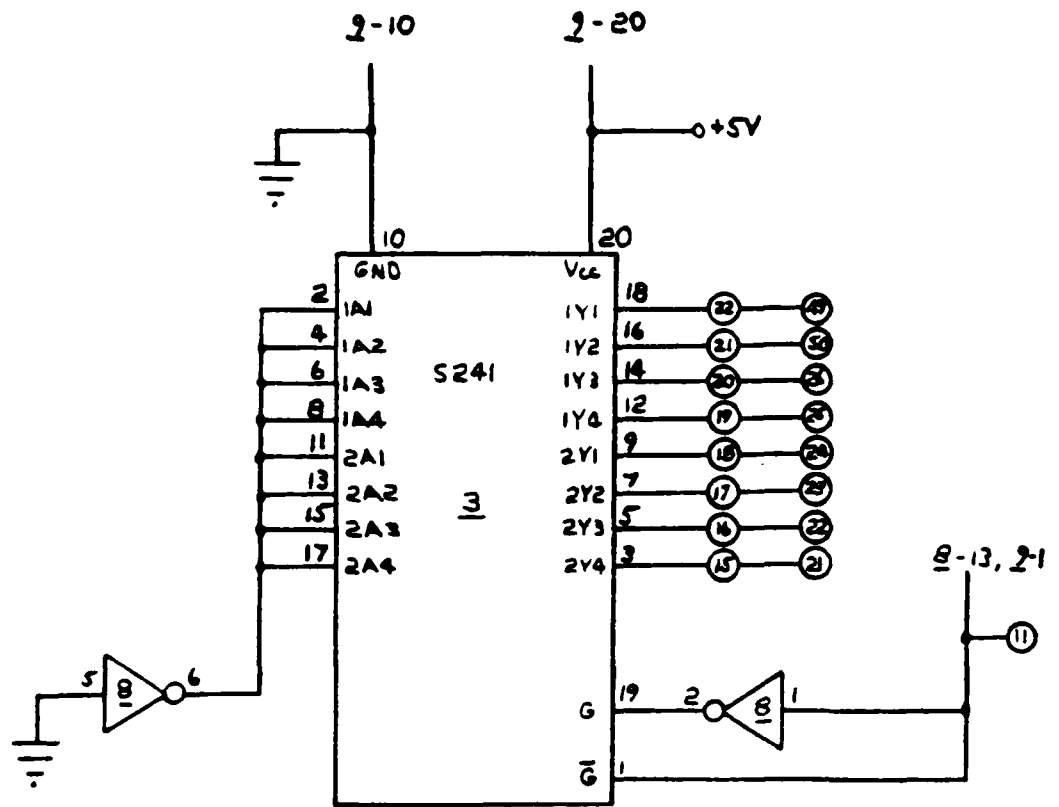

BRL A-TO-D CONVERTER
 ENG: PAT TEXEIRA 2-3645
 DRN: JIM WEISMAN 2-3645
 3-21-86

APPENDIX B

COMPUTER PROGRAM

```

10 !BRL_6_28
11 !-----
13 !PROGRAM FOR OBTAINING THE CALIBRATION CURVE FOR
14 !A GIVEN HOLOGRAM CORNER CUBE COMBINATION.
15 !-----
19 Comments: !This program uses the difference
20 !method for determining the amplitude
21 !for f2 & f1.
28 !The largest Num_samples is 32K.
31 !Graphing is included for 200 enve-
32 !lopes/graph. # of graphs depends on
33 !the number os Num_samples.
54 !Parameters of consideration: Ratios
55 !of f2/f1, degrees/count red(Dpcr),
56 !degrees/count blue(Dpcb)
57 !The doppler effect is included but
58 !not used(It was developed when this
59 !program was configured.). It uses
60 !the parabolic fit to determine the
61 !location of the peak using the greater
62 !of the amplitudes of f1 & f2. The
63 !doppler correction is indepentent for
64 !the red & blue.
66 !For a/d interface- reset for counter
67 !and normal cal switch, up for cal.
68 PRINTER IS 1
70 PRINT CHR$(12)
71 PRINT TABXY(30,15),"CALIBRATION PROGRAM"
72 WAIT 3
73 PRINT TABXY(30,15)," "
74 Initialize: !
75 PRINTER IS 1
76 PRINT CHR$(12) !CLEAR SCREEN
77 ON ERROR GOTO Err_rout
78 OPTION BASE 0
79 GRAPHICS OFF
80 RAD
81 ON KEY 4 LABEL "GRAPH".15 GOSUB Disp_out
82 ENABLE
83 Gpio=12
84 Hpio=704
85 !CONSTANTS
86 Sf=36000 !Sample frequency
87 Gf=3000 !galvo frequency set by clock
88 K1=12 !samples at f1
89 K2=6 !samples at f2
90 K3=4 !samples at f3
91 !Signal generator frequency 576.000Khz
92 !VARIABLE LIST
93 !Num_samp : number of samples to take at 36kz rate
94 !Fb : filter bandwidth
95 !N : INT(Sf/fb)
96 !Nnn :INT (Num_samples/48)*12, used in DMA
97 !Br( ) : array, sampled data, red
98 !Bl( ) : array, sampled data, blue
99 !If1 : interpolation factor for f1
100 !If2 : interpolation factor for f2
101 !F1( ) : convolution multipling function for f1
102 !F2( ) : convolution multipling function for f2
103 !Start : starting point, determined by N
104 !Qr : starting sampled data point for next K1

```

```

105      !interval, including doppler correction, red.
106      !Qb : same as Qr except, blue
107      !Xx : Xx=1, loop for red;Xx=2 loop for blue
108      !B1( ) : Gimbal position for sample, red
109      !B2( ) : Gimbal position for sample, blue
110      !B1K1 : running sum of B1( ) in K1 interval
111      !B2K1 : running sum of B2( ) in K1 interval
112      !Filt_f1(J) : convolution elements in K1 interval, f1
113      !Filt_f2(J) : convolution elements in K1 interval, f2
114      !B1(P) : average of B1( ) in K1 interval
115      !B2(P) : average of B2( ) in k2 interval
116      !P : K1 interval of computation
117      !Ror : running sum of doppler correction, red
118      !Rob : running sum of doppler correction, blue
119      !Rotr(P) : running sum stored as a function of P
120      !Rotb(P) : running sum stored as a function of P
121      !Occr(P) : doppler correction for respective K1 interval, red
122      !Occb(P) : doppler correction for respective K1 interval, blue
123      !Qpsr : quadrant past, red
124      !Qpsb : quadrant past, blue
125      !Qptr : quadrant present, red
126      !Qptb : quadrant present, blue
127      !Qsr : running sum of quadrants, red
128      !Qsb : running sum of quadrants, blue
129      !Tar : total angle red, K1 interval
130      !Tab : total angle blue, K1 interval
131      !Ta_red(P) : total angle red, P K1 interval
132      !Ta_bl(P) : total angle blue. P K1 interval
133      !Whole quadrant update table
134      DIM Qt(5,4)
135      Qt(1,2)=1
136      Qt(1,4)=-1
137      Qt(2,1)=-1
138      Qt(2,3)=1
139      Qt(3,2)=-1
140      Qt(3,4)=1
141      Qt(4,1)=1
142      Qt(4,3)=-1
143      Qsr=10 !Quadrant sum red starts at 10
144      Qsb=10 !Quadrant sum blue starts at 10
145      ASSIGN @Gpio TO 12;WORD
146      !PRINT "      REGISTER STATUS BEFORE DMA"
147      !GOSUB Check_stat
148      Main:! Main program
149      PRINT CHR$(12)
150      GOSUB Num_samp      !# of samples to take
151      !GOSUB Test
152      !GOSUB File_data  ! Copy data from Buffer
153      !to Disk File.
154      !GOSUB File_array
155      GOSUB Filt_bw_int !Input filter bandwidth & interpolation factor
156      BEEP
157      INPUT "If calibration run, Type C. else, Type S, for stored",Aa$
158      IF Aa$="C" OR Aa$="c" THEN
159          GOSUB Dma_transfer
160          GOSUB File_data
161          GOTO 174
162      END IF
163      IF Aa$="S" OR Aa$="s" THEN
164          DISP "INSERT DATA DISK - PRESS CONT TO CONTINUE"
165          PAUSE

```

```

166     CAT
167     GOSUB File_array
168     GOTO 174
169     END IF
170     BEEP
171     BEEP
172     BEEP
173     GOTO 157
174     GOSUB Mult_fun      !Generate multiplier
175                         !functions.
176     GOSUB Comp_angle   !Convolution, envelop detection, doppler correction,
177                         !& Arctan for red and blue
178     DISP
179     GOSUB Disp_out
180     GOTO 1
181     !+++++
182     Num_samp: !Input the total number of samples
183               !to be taken. Maximum of 32K
184     BEEP
185     Num_samples=30000
186     GOTO 188
187     INPUT "TOTAL NUMBER OF SAMPLES TO BE TAKEN?".Num_samples
188     ALLOCATE REAL Ta_red(INT(Num_samples/K1)),Ta_bl(INT(Num_samples/K1)),Rot(I
NT(Num_samples/K1))
189     RETURN
190     Dma_transfer: !
191     DISP "                COLLECTING DATA"
192     S=0
193     INTEGER Kk(0:47) BUFFER
194     ASSIGN @Buf TO BUFFER Kk(+)
195     !RESET DATA TRANSFER ELECTRONICS
196     CONTROL Gpio,2;2 !SET CTL0 & CTL1 TO 0
197     CONTROL Gpio,2;0 !SET CTL0 TO 1 & CTL1 TO 0
198     CONTROL Gpio,2;2 !SET CTL0 & CTL1 TO 1
199     !END RESET
200     CONTROL @Buf,4;0
201     CONTROL Gpio,0;2
202     CONTROL Gpio,3;0
203     !SET TRANSFER LOW
204     CONTROL Gpio,2;3 !SET CLT0 TO 0, XFER 0
205     !BEEP
206     TRANSFER @Gpio TO @Buf
207     FOR X=0 TO 47 STEP 4
208         Br(S)=Kk(X)-126
209         B1(S)=Kk(X+1)+126
210         B1(S)=Kk(X+2)+1
211         B2(S)=Kk(X+3)+1
212     ! PRINT S,Br(S),B1(S),B1(S),B2(S)
213         S=S+1
214     NEXT X
215     IF S=Num THEN
216         GOTO 220
217     ELSE
218         GOTO 196
219     END IF
220     CONTROL Gpio,2;2 !SET CLT0 & CLT1 TO 1
221     CONTROL Gpio,1;3
222     DISP
223     !PRINT "                REGISTER STATUS AFTER DMA"
224     !GOSUB Check_stat
225     BEEP

```

```

226 RETURN
246 Filt_bw_int:!!Input filter bandwidth in hertz
247 BEEP
250 INPUT "WHAT IS THE DESIRED FILTER BANDWIDTH IN HERTZ?",Fb
251 N=INT(Sf/Fb)
253 Nnn=INT(Num_samples/48)*12
254 ALLOCATE INTEGER Br(0:Nnn),INTEGER B1(0:Nnn)
255 ALLOCATE INTEGER B1(0:Nnn),INTEGER B2(0:Nnn)
256 ALLOCATE INTEGER Rotr(0:Nnn),Rotb(0:Nnn),Qccr(0:Nnn),Qccb(0:Nnn)
257 PRINT CHR$(12)
258 BEEP
262 INPUT "Real samples f1=12, interpolation factor?",If1
263 BEEP
264 INPUT "Real samples f2=6, interpolation factor?",If2
265 BEEP
266 ALLOCATE REAL Filt_f1(1:K1*If1),Filt_f2(1:K1*If2)
267 RETURN
268 Test:!! Generate data - needs to be modified for this
269 !program
272 BEEP
273 INPUT "What is the Envelop Peak Amplitude?",Epa
274 BEEP
275 DISP " GENERATING DATA"
276 Peak_value_data=0
277 Gal_cyc_frg=200
278 Ab=0
279 ALLOCATE INTEGER Mmm(0:Num_samples-1)
280 FOR X=0 TO Num_samples-1 STEP 4
281 Ac=Epa*SIN((PI*(+Ab))/(6*Gal_cyc_frg)+(2.7)*SIN(2*PI*Ab*Gf/Sf))
282 FOR Y=X TO X+3
283 Mmm(Y)=INT(Ac)+128
284 !PRINT Y,Mmm(Y)
285 OUTPUT @Buffer USING "#,B";Mmm(Y)
286 NEXT Y
287 Ab=Ab+1
288 NEXT X
289 DISP
290 GOSUB Check_stat
291 WAIT 5
292 RETURN
293 Mult_fun: !Generation of the multiplying function.
294 !Multiplying function will be (SIN(X)/(X))*COS(Y)
295 !PRINTER IS 705
296 !ALLOCATE REAL F1(0:(N*If1)),REAL F2(0:(N*If2))
297 DIM F1(0:2000),F2(0:2000)
298 RAD
299 BEEP
300 !Generate 1/2 multiplier function for F1
301 BEEP
302 DISP "Building multiplier function for F1"
303 F1(0)=1
304 !PRINT "F1(0)=";F1(0)
305 FOR P=1 TO N*If1
306 Aa=(PI*P)/(N*If1)
307 Bb=(Aa+2*Gf)/Fb
308 !PRINT "P=";P
309 !PRINT "N=";N*If1
310 !PRINT "(PI*P)/N=";Aa
311 !PRINT "(Aa+2*GF)/FB=";Bb
312 F1(P)=(SIN(Aa)/Aa)*COS(Bb)
313 !PRINT "F1(";P;")=";F1(P)

```

```

314 NEXT P
315 DISP "Building multiplier function for F2"
316 !Generate 1/2 of multiplier function for F2
317 F2(0)=1
318 !PRINT "F2(0)=";F2(0)
319 FOR P=1 TO N*If2
320 Aa=(PI*P)/(N*If2)
321 Bb=(Aa*4*Gf)/Fb
322 !PRINT "P=";P
323 !PRINT "N=";N
324 !PRINT "(PI*P)/N=";Aa
325 !PRINT "(Aa*4*GF)/FB=";Bb
326 F2(P)=(SIN(Aa)/Aa)*COS(Bb)
327 !PRINT "F2(";P;")=";F2(P)
328 NEXT P
329 RETURN
330 !
331 !.....
332 !Convolution and envelop detection
333 !at K1 intervals for f1 and f2.
334 !.....
335 !
336 Comp_angle:!Filter, envelop detection,
337 !doppler correction and
338 !arctan for red & blue
339
340 RAD
341 Tot_angle_peak=0
342 P=0 !Initialization of array for the out-
343 !put angle for red and blue lasers.
344 !Determine first data point to start con-
345 !volution considering the value of N and
346 !the need of a + slope for f1 for synchr-
347 !onization.
348 Quotient=(N+1) DIV K1
349 Start=(Quotient+1)*12
351 BEEP
353 DISP " CRUNCHING DATA"
355 PRINT "Start=";Start
356 Qq=0 !Initialize graph index. Increment
357 !Qq for each 200 computations
361 Qr=Start+2-3
362 Qb=Qr
363 FOR Xx=1 TO 2 !1=red,2=blue
364 IF Xx=1 THEN
365 Q=Qr
366 ELSE
367 Q=Qb
368 END IF
369 B1k1=0
370 B2k1=0
373 !.....
374 Con_f1:!
375 !Convolution over K1 interval for
376 !f1
377 !.....
378 J=1
379 Peak_value_f1=0
380 FOR X=0 TO Q+K1-1
381 IF Xx=1 THEN B1k1=B1(X)+B1k1
382 IF Xx=2 THEN B2k1=B2(X)+B2k1
383 FOR C=0 TO If1-1

```

```

384      Sum_f1=0
385      IF Xx=1 THEN !Xx=1,Red:Xx=2,Blue
386          FOR M=X TO X+N
387              Product_f1=Br(M+1)*F1((M-X)*If1-C+If1)+Br(2*X-M)*F1((M-X)*If1+C)
388              Sum_f1=Sum_f1+Product_f1
389              ! PRINT Q:TAB(10);X:TAB(20);C:TAB(30);M:TAB(40);J:TAB(45);((M-X)*
If1+C);
390              ! PRINT TAB(50);((M-X)*If1-C+If1);
391              ! PRINT TAB(60);(2*X-M-1)
392          NEXT M
393      ELSE
394          FOR M=X TO X+N
395              Product_f1=B1(M+1)*F1((M-X)*If1-C+If1)+B1(2*X-M)*F1((M-X)*If1+C)
396              Sum_f1=Sum_f1+Product_f1
397              ! PRINT Q:TAB(10);X:TAB(20);C:TAB(30);M:TAB(40);J:TAB(45);((M-X)
+If1+C);
398              ! PRINT TAB(50);((M-X)*If1-C+If1);
399              ! PRINT TAB(60);(2*X-M-1)
400          NEXT M
401      END IF
402      Filt_f1(J)=Sum_f1
403      !PRINTER IS 705
404      !PRINT "Filt_f1(";J;"=");Filt_f1(J)
405      !PRINTER IS 1
406      IF ABS(Filt_f1(J))>Peak_value_f1 THEN
407          Peak_value_f1=ABS(Filt_f1(J))
408      END IF
409      J=J+1
410  NEXT C
411  NEXT X
412      IF Xx=1 THEN B1(P)=INT(B1k1/12)
413      IF Xx=2 THEN B2(P)=INT(B2k1/12)
414      !.....
420  Env_f1: !Envelop detection over k1
421      !interval for f1
422      !.....
423      Diff_plus_f1=0
424      Diff_minus_f1=0
425      FOR E=If1+1 TO 5*If1+1
426          Diff_f1=Filt_f1(E)-Filt_f1(E+INT(If1*k1/2))
427          IF Diff_f1>Diff_plus_f1 THEN
428              Diff_plus_f1=Diff_f1
429          END IF
430          IF Diff_f1<Diff_minus_f1 THEN
431              Diff_minus_f1=Diff_f1
432          END IF
433              !PRINT "e=";E;"Diff_f1=";Diff_f1
434              !PRINT "Diff_plus_f1=";Diff_plus_f1
435              !PRINT "Diff_minus_f1=";Diff_minus_f1
436      NEXT E
437      !Value of Envelop at P interval for f1
438      IF Diff_plus_f1>ABS(Diff_minus_f1) THEN
439          Envelop_f1=Diff_plus_f1
440      ELSE
441          Envelop_f1=Diff_minus_f1
442      END IF
478  !.....
479  Con_f2: !
480      !Convolution over k1 interval for f1
481      !.....
483      J=1

```

```

484 Peak_value_f2=0
485 FOR X=Q TO Q+K1-1
486   FOR C=0 TO If2-1
487     Sum_f2=0
488     IF Xx=1 THEN !Xx=1,Red:Xx=2,Blue
489       FOR M=X TO X+N
490         Product_f2=Br(M+1)*F2((M-X)*If2-C+If2)+Br(2*X-M)*F2((M-X)*If2+C)
491         Sum_f2=Sum_f2+Product_f2
492         ! PRINT Q;TAB(10);X;TAB(20);C;TAB(30);M;TAB(40);J;TAB(45);((M-X)
+If2+C);
493         ! PRINT TAB(50);((M-X)*If2-C+If2);
494         ! PRINT TAB(60);(2*X-M-1)
495       NEXT M
496     ELSE
497       FOR M=X TO X+N
498         Product_f2=B1(M+1)*F2((M-X)*If2-C+If2)+B1(2*X-M)*F2((M-X)*If2+C)
499         Sum_f2=Sum_f2+Product_f2
500         ! PRINT Q;TAB(10);X;TAB(20);C;TAB(30);M;TAB(40);J;TAB(45);((M-X)
+If2+C);
501         ! PRINT TAB(50);((M-X)*If2-C+If2);
502         ! PRINT TAB(60);(2*X-M-1)
503       NEXT M
504     END IF
505     Filt_f2(J)=Sum_f2
506     !PRINTER IS 705
507     !PRINT "Filt_f2(";J;")";Filt_f2(J)
508     !PRINTER IS 7
509     IF ABS(Filt_f2(J))>Peak_value_f2 THEN
510       Peak_value_f2=ABS(Filt_f2(J))
511     END IF
512     J=J+1
513   NEXT C
514 NEXT X
520 .....
521 Env_f2: Envelop detection over fract-
522 ional interval of K1 for f2
523  using 1/2 cycle difference
524 .....
525 .....
526 Diff_plus_f2=0
527 Diff_minus_f2=0
528 FOR E=If2+1 TO 5*If2+1
529   Diff_f2=Filt_f2(E)-Filt_f2(E+3*If2)
530   IF Diff_f2>Diff_plus_f2 THEN
531     Diff_plus_f2=Diff_f2
532   END IF
533   IF Diff_f2<Diff_minus_f2 THEN
534     Diff_minus_f2=Diff_f2
535   END IF
536 NEXT E
537 !value of Envelop at P interval for f2
538 IF Diff_plus_f2>ABS(Diff_minus_f2) THEN
539   Envelop_f2=Diff_plus_f2
540 ELSE
541   Envelop_f2=-Diff_minus_f2
542 END IF
543 !PRINT "Envelop_f2";Envelop_f2
544 .....
545 ..... FOR THE DOPPLER EFFECT FOR RED
546 AND BLUE
547 .....
548 IF ABS(Envelop_f1)>ABS(Envelop_f2) THEN

```



```

558     FOR E=If1+1 TO 5*If1+1
560         D2=Filt_f1(E+2)-Filt_f1(E+1)
561         D1=Filt_f1(E+1)-Filt_f1(E)
562         !PRINT "D2=";D2,"D1=";D1,"(D2-D1)=";D2-D1,"E=";E
563         IF D2=0 OR SGN(D1)+SGN(D2)=0 THEN
564             GOTO 571
565         END IF
566     NEXT E
567     Dsq=D2-D1
568     Ap=Filt_f1(E)
569     Bp=D1-Dsq/2
570     Cp=Dsq/2
571     Envelop_f11=(Ap-(Bp^2)/(4*Cp))
572     !PRINT "Envelop_f11=";Envelop_f11
573     Ee=E-Bp/(2*Cp)
574     !PRINTER IS 705
575     PRINT "Ee_f1=";Ee
576     PRINTER IS 1
577     Qc=0
578     IF Ee>4*If1+1 THEN Qc=-1
579     IF Ee<2*If1+1 THEN Qc=+1
580     ELSE
581     FOR E=If2+1 TO 5*If2+1
582         D2=Filt_f2(E+2)-Filt_f2(E+1)
583         D1=Filt_f2(E+1)-Filt_f2(E)
584         !PRINT "D2=";D2,"D1=";D1,"(D2-D1)=";D2-D1,"E=";E
585         IF D2=0 OR SGN(D1)+SGN(D2)=0 THEN
586             GOTO 626
587         END IF
588     NEXT E
589     Dsq=D2-D1
590     Ap=Filt_f2(E)
591     Bp=D1-Dsq/2
592     Cp=Dsq/2
593     Envelop_f22=(Ap-(Bp^2)/(4*Cp))
594     !PRINT "Envelop_f22=";Envelop_f22
595     Ee=E-Bp/(2*Cp)
596     !PRINTER IS 705
597     PRINT "Ee_f2=";Ee
598     PRINTER IS 1
599     Qc=0
600     IF Ee>4*If2+1 THEN Qc=-1
601     IF Ee<2*If2+1 THEN Qc=+1
602     END IF
603     IF Xx=1 THEN
604         !PRINTER IS 705
605         Ror=Ror+Qc
606         PRINT "Ror=";Ror,
607         Rotr(P)=Ror
608         Qccr(P)=Qc
609         PRINT "Qc=";Qc
610         Or=Or+Qc+K1
611         PRINT "Or=";Or
612         PRINTER IS 1
613     ELSE
614         Rob=Rob+Qc
615         PRINT "Rob=";Rob
616         Rotb(P)=Rob
617         Qccb(P)=Qc
618         PRINT "Qc=";Qc,
619         Qb=Qb+Qc+K1

```

```

661 PRINT "Qb=":Qb
662 END IF
663 E_f1=Envelop_f1
664 E_f2=4*Envelop_f2
665 PRINT "Envelop_f2/Envelop_f1=":Envelop_f2/Envelop_f1
666 !.....
667 Arc_t:!Computation of the angle from the
668 !arctan(Envelop_f2/Envelop_f1) and
669 !counting of the whole quadrants
670 !.....
671 BEEP 500,.2
672 PRINTER IS 1
673 DEG
674 IF Xx=1 THEN ! Arc_t for Red laser
675 IF E_f1=0 THEN !Take care of divide by zero
676 IF Qpsr=1 OR Qpsr=3 THEN
677 Tar=(Qsr)*90+90
678 GOTO 716
679 ELSE
680 Tar=(Qsr)*90
681 GOTO 716
682 END IF
683 END IF
684 Ra=E_f2/E_f1
685 !Determine Quadrant & total_angle(P)_
686 IF ABS(Ra)>=60 THEN
687 IF SGN(Ra)=1 THEN
688 Ra=60
689 ELSE
690 Ra=-60
691 END IF
692 END IF
693 IF SGN(Ra)=1 THEN !Plus Ratio
694 IF SGN(E_f1)=1 THEN ! Deno plus
695 Qptr=1
696 ELSE
697 Qptr=3
698 END IF
699 Tar=(Qt(Qpsr,Qptr)+Qsr)*90+ATN(Ra)-900
700 ELSE
701 IF SGN(E_f1)=1 THEN
702 Qptr=4
703 ELSE
704 Qptr=2
705 END IF
706 Tar=(Qt(Qpsr,Qptr)+Qsr)*90+90+ATN(Ra)-900
707 END IF
708 Qsr=Qt(Qpsr,Qptr)+Qsr
709 IF P>1 THEN Qpsr=Qptr
710 PRINTER IS 705
711 PRINT P,PROUND(Tar,-2),Qpsr,Qptr,B1(Q),B1(P)
712 PRINTER IS 1
713 Ta_red(P)=Tar
714 PRINTER IS 705
715 PRINT P,"Ta_red=":PROUND(Ta_red(P),-2),"E_F1=":E_f1,"E_F2=":E_f2
716 PRINTER IS 1
717 ELSE!Arc_t for blue laser
718 IF E_f1=0 THEN !Take care of divide by zero
719 IF Qpsb=1 OR Qpsb=3 THEN
720 Tab=(Qsb)*90+90
721 GOTO 763

```

```

733     ELSE
734         Tab=(Qsb)*90
735         GOTO 763
736     END IF
737 END IF
738 Ra=E_f2/E_f1
739 !Determine Quadrant & Total_angle(P)_
740 IF ABS(Ra)>=60 THEN
741     IF SGN(Ra)=1 THEN
742         Ra=60
743     ELSE
744         Ra=-60
745     END IF
746 END IF
747 IF SGN(Ra)=1 THEN !Plus Ratio
748     IF SGN(E_f1)=1 THEN ! Deno plus
749         Qptb=1
750     ELSE
751         Qptb=3
752     END IF
753     Tab=(Qt(Qpsb,Qptb)+Qsb)*90+ATN(Ra)-900
754 ELSE
755     IF SGN(E_f1)=1 THEN
756         Qptb=4
757     ELSE
758         Qptb=2
759     END IF
760     Tab=(Qt(Qpsb,Qptb)+Qsb)*90+90+ATN(Ra)-900
761 END IF
762 Qsb=Qt(Qpsb,Qptb)+Qsb
763 IF P>1 THEN Qpsb=Qptb
764 PRINTER IS 705
765 PRINT P,PROUND(Tab,-2),Qpsb,Qptb,B1(Q),B1(P)
766 Ta_b1(P)=Tab
767 PRINT P,"Ta_b1=";PROUND(Ta_b1(P),-2),"E_F1=";E_f1,"E_F2=";E_f2
768 END IF!For red or blue
769 PRINTER IS 1
770 NEXT Xx
771 RAD
772 PRINT
773 !This completes the angle computation
774 !for the red and blue for this K1 interval P
775 P=P+1
776 !Test to increment Qq or not
777 IF P=0 THEN
778     Qq=0
779 ELSE
780     Rmdr=P MOD 199     !P starts at 0
781     IF Rmdr=0 THEN Qq=Qq+1
782 END IF
783 INEXT Q
784 IF Q>=Nnn-N-25-Start THEN RETURN
785 GOTO 363
786 Disp_out:!Graph data
787 Dpcr=.064     !Degrees/count gimbal red
788 Dpcb=.064     !Degrees/count gimbal blue
789 DUMP DEVICE IS 705
790 PRINTER IS 705
791 PEN 2
792 PRINT CHR$(12);     !Clear alpha & form feed
793 DISP

```

```

796 GINIT          !Initialize
797 GRAPHICS ON    !Raster on
798 FOR Qqq=0 TO Qq !Graph index
799   FOR R=1 TO 2 !red=1, blue=2
800     PEN 2
801     WINDOW -25,200,-500,500!Set window
802     AXES 20,100
803     LORG 6
804     FOR I=0 TO 180 STEP 40
805       MOVE I,0
806       LABEL Qqq*200+I
807     NEXT I
808   !
809   LORG 8
810   FOR I=-400 TO 400 STEP 100
811     MOVE 0,I
812     LABEL I
813   NEXT I
814   !
815   LORG 5
816   MOVE 100,475
817   PEN 6
818   LABEL "ANGLE AS A FUNCTION OF ENVELOP SAMPLES"
819   MOVE 180,425
820   IF R=1 THEN
821     PEN 2
822     LABEL "RED"
823     MOVE 180,400
824     LABEL Name$
825     PEN 6
826   END IF
827   IF R=2 THEN LABEL "BLUE"
828     MOVE 180,-400
829     LABEL Name$
830     PEN 2
831     MOVE -13,0
832     LORG 6
833     LABEL "Samp"
834     LORG 5
835     MOVE 100,-475
836     LABEL Title$:"ENVELOP SAMPLE RATE, 3KHZ"
837     PEN 0
838     MOVE 0,0
839     PEN 2
840     FOR X=0 TO 199 !graph data
841       IF R=1 THEN
842         Tb=Ta_red(Qqq*200+X+4)-Ta_red(4)
843       ELSE
844         Tb=Ta_b1(Qqq*200+X+4)-Ta_b1(4)
845       END IF
846       DRAW X,Tb
847     NEXT X
848     PEN 0
849     MOVE 0,0
850     PEN 6
851     FOR X=0 TO 199 !Graph dmbal
852       IF R=1 THEN
853         Bbb=B1(Qqq*200+X+4)*Dpccr-B1(4)*Dpccr
854       ELSE
855         Bbb=B2(Qqq*200+X+4)*Dpccb-B2(4)*Dpccb
856       END IF
857     NEXT X
858   END IF

```

```

860         DRAW X,-Bbb
861     NEXT X
862     PEN 0
863     PAUSE
864     !DUMP GRAPHICS
865     !PRINT CHR$(12)
866     GCLEAR
867     NEXT K
868     NEXT Qqq
869     ALPHA ON
870     PRINTER IS 1
871     DISP "STOP"
872     PAUSE
873     RETURN
874 Check_stat: !Status check on Buffer.
875     PRINT "      REGISTER STATUS @Buffer"
876     FOR X=1 TO 5
877         STATUS @Buffer,X:A
878         PRINT "REGISTER ":X,A
879     NEXT X
880         !DISP "PAUSE - PRESS CONTINUE TO CONTINUE"
881     BEEP
882         !PAUSE
883     WAIT 5
884     PRINT CHR$(12)
885     RETURN
886 err_rout: !Routine for error recovery
887     BEEP
888     BEEP
889     BEEP
890     DISP ERRMS
891     PAUSE
892     GOSUB Disp_out
893     PAUSE
894     !
895 File data: !Transfer of data from Buffer
896         !to disk
897     !
898     BEEP
899     DISP "INSERT A FORMATTED DATA DISK!!!!!! -- PRESS CONT TO CONT"
900     PAUSE
901     !Create a BDAT file for the data.
902     INPUT "NAME OF DATA FILE TO BE CREATED?".Name$
903     IF Name$="" THEN 901
904     BEEP
905     DISP "CREATING A DATA FILE"
906     !Record length is 1
907     CREATE BDAT Name$":INTERNAL".8*Nnn+4,2
908     !Assign an I/O path
909     ASSIGN @file TO Name$":INTERNAL"
910     GOSUB Check_stat_r
911     PRINT CHR$(12)
912     DISP "TRANSFERRING DATA FROM BUFFER TO FILE"
913     OUTPUT @file;B1(*),B1(*),B1(*),B2(*)
914     ASSIGN @file TO *
915     WAIT 5
916     DISP "TRANSFER COMPLETE"
917     WAIT 5
918     DISP
919     PRINT CHR$(12)
920     RETURN

```

```

921      !
922 File_array: !Transfer from file to array
923      !
924      INPUT "NAME OF DATA FILE?",Name$
925      ASSIGN @File TO Name$:INTERNAL"
926      BEEP
929      DISP "TRANSFERRING FROM DATA FILE TO AN ARRAY"
930      ENTER @File;Br(*),B1(*),B1(*),B2(*)
931      PRINT CHR$(12)
933      DISP "TRANSFER COMPLETE"
934      WAIT 3
938      !GOSUB Check_stat
939      !GOSUB Check_stat_r
940      !GOSUB Check_stat
941      DISP
942      RETURN
943 Check_stat_r: !Status check on File.
944      BEEP
945      PRINT "          REGISTER STATUS @File"
946      FOR R=1 TO 5
947          STATUS @File,R:A
948          PRINT "REGISTER ";R,A
949      NEXT R
950          !DISP "PAUSE - PRESS CONTINUE TO CONTINUE"
951      BEEP
952          !PAUSE
953      WAIT 5
954      PRINT CHR$(12)
955      RETURN
956      END

```

Cross Reference <<<<

* Numeric Variables										
A	877	878	947	948						
A_to_d_reset										
Aa	306	307	312	320	321	326				
Ab	278	281	287							
Ac	281	283								
Ap	572	577	627	630						
B1	210	255	381	412	719	766	856	913	930	
B1_peak										
Bk1	369	381	412							
B2	211	255	382	413	858	913	930			
B2_peak										
Bk1	370	382	413							
Bb	307	312	321	326						
Bb2										
Bbb	856	858	860							
Bbb2										
B1	209	254	395	498	913	930				
B2	574	577	580	628	630	632				
B3	208	254	387	490	913	930				
butter array										
bu_label										
check_stat	383	387	395	410	486	490	498	513		
check_stat2										
Comp_andie										
cont_t										
C	575	577	580	629	630	632				
C1										
C2										
C3										
C4										
C5	567	562	571	574	619	621	626	637		
C6	561	563	571	618	621	626				
C7	426	427	428	430	431					
C8	529	530	531	533	534					
Diff_minus_t1	424	430	431	438	441					
Diff_minus_t2	527	533	534	541	544					
Diff_plus_t1	423	427	428	438	439					
Diff_plus_t2	526	530	531	541	542					
disp_con										
disp_data										
disp_data2										
disp_data3										
disp_data4										
disp_data5										
disp_data6										
disp_data7										
disp_data8										
disp_data9										
disp_data10										
disp_data11										
disp_data12										
disp_data13										
disp_data14										
disp_data15										
disp_data16										
disp_data17										
disp_data18										
disp_data19										
disp_data20										
disp_data21										
disp_data22										
disp_data23										
disp_data24										
disp_data25										
disp_data26										
disp_data27										
disp_data28										
disp_data29										
disp_data30										
disp_data31										
disp_data32										
disp_data33										
disp_data34										
disp_data35										
disp_data36										
disp_data37										
disp_data38										
disp_data39										
disp_data40										
disp_data41										
disp_data42										
disp_data43										
disp_data44										
disp_data45										
disp_data46										
disp_data47										
disp_data48										
disp_data49										
disp_data50										
disp_data51										
disp_data52										
disp_data53										
disp_data54										
disp_data55										
disp_data56										
disp_data57										
disp_data58										
disp_data59										
disp_data60										
disp_data61										
disp_data62										
disp_data63										
disp_data64										
disp_data65										
disp_data66										
disp_data67										
disp_data68										
disp_data69										
disp_data70										
disp_data71										
disp_data72										
disp_data73										
disp_data74										
disp_data75										
disp_data76										
disp_data77										
disp_data78										
disp_data79										
disp_data80										
disp_data81										
disp_data82										
disp_data83										
disp_data84										
disp_data85										
disp_data86										
disp_data87										
disp_data88										
disp_data89										
disp_data90										
disp_data91										
disp_data92										
disp_data93										
disp_data94										
disp_data95										
disp_data96										
disp_data97										
disp_data98										
disp_data99										
disp_data100										

Envelop_f22	630									
Epa	273	281								
Err_rout										
F1	297	<-DEF	303	312	387	395				
F2	297	<-DEF	317	326	490	498				
Fb	250	251	307	321						
File_array										
File_data										
Filt_bw_int										
Filt_f1	266	402	406	407	426	560	561	572		
Filt_f11b										
Filt_f11r										
Filt_f1b										
Filt_f1r										
Filt_f2	266	505	509	510	529	618	619	627		
Filt_f22b										
Filt_f22r										
Filt_f2b										
Filt_f2r										
Gal_cyc_frg	277	281								
Gf	87	281	307	321						
Gpio	83	196	197	198	201	202	204	220	221	
Hpb	84									
I	804	805	806	807	810	811	812	813		
I1	262	266	305	306	383	387	395	425	426	55
I2	594	595								
I2	264	266	319	320	486	490	498	528	529	617
I3	639	640								
I4	378	402	406	407	409	483	505	509	510	512
I5	88	188	266	348	380	426	485	650	660	
I6	89									
I7	90									
I8	193	<-DEF	194	208	209	210	211			
I9	386	387	392	394	395	400	489	490	495	497
I10	498	503								
Max_x_axis										
Mnn	279	283	285							
Mn										
Mult_fun										
N	251	305	306	319	320	348	386	394	489	497
N1	785									
Nnn	215	253	254	255	256	785	907			
Ns										
Num_samp										
Num_samples	185	187	188	253	279	280				
Op										
O1	201	306	312	314	319	320	326	328	340	40
O2	413	647	648	657	658	716	715	722	725	77
O3	766	767	768	776	778	781				
O4	276									
Peak_value_data	379	406	407							
Peak_value_f1										
Peak_value_f11t										
Peak_value_f11r										
Peak_value_f1b										
Peak_value_f1r										
Peak_value_f2	484	509	510							
Peak_value_f22t										
Peak_value_f22r										
Peak_value_f2b										
Peak_value_f2r										
Product_f1	387	388	395	396						

Product_f2	490	491	498	499						
Q	365	367	380	485	719	766	785			
Qb	362	367	660	661						
Qc	593	594	595	638	639	640	645	648	649	650
	655	658	659	660						
Qccb	256	658								
Qccr	256	648								
Qj										
Upsb	730	753	760	762	763	766				
Upsr	683	706	713	715	716	719				
Optb	749	751	753	756	758	760	762	763	766	
Qptr	702	704	706	709	711	713	715	716	719	
Qq	356	779	782	798						
Uaq	798	806	845	847	856	858	868			
Qr	361	362	365	650	651					
Usb	144	731	734	753	760	762				
Qsr	143	684	687	706	713	715				
Qt	134	-DEF	135	136	137	138	139	140	141	142
	706	713	715	753	760	762				
Quotient	349	349								
R	799	820	829	844	855	867	946	947	948	949
Ra	691	693	694	695	697	700	706	713	738	740
	741	742	744	747	753	760				
Range_stored										
Rndr	777	780								
Rob	656	656	657							
Ror	645	646	647							
Rot	188									
Rotp	256	657								
Rotr	256	647								
	192	208	209	210	211	213	215			
	87	251	281							
Rsp										
Rstart	349	355	361	785						
Sum_f1	384	388	396	402						
Sum_f2	467	491	499	505						
sys_deflt										
sys_defl_red										
Ta_bl	188	767	768	847						
Ta_red	188	722	725	845						
Tac	731	734	753	760	766	767				
Tar	684	687	706	713	719	722				
Tb	845	847	849							
Test_data										
Tot_max										
Tot_angle_pear	341									
	207	208	209	210	211	214	280	282	288	38
	381	382	386	387	394	395	411	485	489	490
	497	498	514	843	845	847	849	850	854	856
	858	860	861	876	877	878	879			
	77	384	387	387	389	412	413	488	647	647
	287	285	285	286						
Trans_variables										
Has	747	750	750	91	917	919	924	925		
Varied	875	875	917	917	917	919	924	925		
Total	875									

* I/O Path Names
@Buf 194 200 206
@Buffer 285 877
@File 909 913 914 925 930 947
@Gpio 145 206

* Line Labels
A_to_d_reset
Arc_t 672 <-DEF
Buffer_array
Bw_label
Check_stat 290 874 <-DEF
Check_stat_r 910 943 <-DEF
Comments 19 <-DEF
Comp_angle 176 336 <-DEF
Con_f1 374 <-DEF
Con_f2 479 <-DEF
Constants
Disp_con
Disp_data
Disp_data_1
Disp_data_2
Disp_out 81 179 788 <-DEF 892
Dna_transfer 159 190 <-DEF
Doppler_cor
Env_f1 420 <-DEF
Env_f2 521 <-DEF
Err_rout 77 886 <-DEF
File_array 167 922 <-DEF
File_data 160 895 <-DEF
Filt_bu_int 155 246 <-DEF
Index
Initialize 74 <-DEF
Main 148 <-DEF
Mult_fun 174 293 <-DEF
Num_samp 150 180 <-DEF
Range_stored
Test 268 <-DEF
Test_data
Var_list

* Line Numbers
1
2
3
4
5
11
12
13
14
15
16
17
18
19
20
21
22
23
24
25
26
27
28
29
30
31
32
33
34
35

221		
226		
240		
245		
249		
363	787	
372		
390		
524		
526		
540		
546		
548		
562		
571	567	
578		
600		
626	622	
634		
635		
640		
679		
682		
691		
716	685	688
729		
738		
763	732	735
814		
816		
821		
822		
823		
824		
825		
826		
827		
828		
829		
830		
831		
832		
833		
834		
835		
836		
837		
838		
839		
840		
841		
842		
843		
844		
845		
846		
847		
848		
849		
850		
851		
852		
853		
854		
855		
856		
857		
858		
859		
860		
861		
862		
863		
864		
865		
866		
867		
868		
869		
870		
871		
872		
873		
874		
875		
876		
877		
878		
879		
880		
881		
882		
883		
884		
885		
886		
887		
888		
889		
890		
891		
892		
893		
894		
895		
896		
897		
898		
899		
900		
901		
902		
903		
904		
905		
906		
907		
908		
909		
910		
911		
912		
913		
914		
915		
916		
917		
918		
919		
920		
921		
922		
923		
924		
925		
926		
927		
928		
929		
930		
931		
932		
933		
934		
935		
936		
937		
938		
939		
940		
941		
942		
943		
944		
945		
946		
947		
948		
949		
950		
951		
952		
953		
954		
955		
956		
957		
958		
959		
960		
961		
962		
963		
964		
965		
966		
967		
968		
969		
970		
971		
972		
973		
974		
975		
976		
977		
978		
979		
980		
981		
982		
983		
984		
985		
986		
987		
988		
989		
990		
991		
992		
993		
994		
995		
996		
997		
998		
999		
1000		

MISSOURI STATE ARCHIVES

IBRLE_1R

Comments: PROGRAM FOR DATA ACQUISITION AND
DATA PROCESSING OF RANGE DATA.

This program uses the difference method for determining the amplitude for f1 & f2.
Graphing is included for 200 envelopes/graph. # of graphs depends on the number of Num_samples.
Parameters of consideration: Ratios for f2/f1, degrees/count red(Dpcr).
The phase correction, doppler effect is included.
The parabolic fit is used to determine the location of the peak using the greater of the amplitudes of f1 & f2. The phase correction is independent for the red & blue.
IAU Interface - Switch position NORMAL.
PRINTER IS 1
PRINT CHR\$(10)
PRINT TAB(19,5), "RANGE PROGRAM"
PRINT
PRINT CHR\$(10)
PRINT TAB(19,5), "INDEX TO ROUTINE"
.....
INDEX TO ROUTINE

Comments:
 IBlock
 IBlock_val
 IBlock_start
 IBlock_end
 IBlock_size
 IBlock_transfer
 IBlock_buffer
 IBlock_array
 IBlock_data
 IBlock_index
 IBlock_offset
 IBlock_size
 IBlock_start
 IBlock_end
 IBlock_size
 IBlock_transfer
 IBlock_buffer
 IBlock_array
 IBlock_data
 IBlock_index
 IBlock_offset

```

115 GRAPHICS OFF
116 RAD
117 ON KEY 4 LABEL "GRAPH",15 GOSUB Disp Out
118 ENABLE
119 Gpio=12
120 Hpio=704
121 !::::::::::::::::::::::::::::::::::::::::::
122 Constants:
123 !
124 !-----
125 Sf=36000 !Sample frequency
126 Gf=3000 !galvo frequency set by clock
127 K1=12 !samples at f1
128 K2=6 !samples at f2
129 K3=4 !samples at f3
130 Sys_del_red=-0 !-3 for data acquisition
131 !+0 for Test_data
132 Sys_del_bl=-0 !-3 for data acquisition
133 !+0 for Test_data
134 !Signal generator frequency 576.000kHz
135 !::::::::::::::::::::::::::::::::::::::::::
136 Var_list: !Variable list
137 !-----
138 !Num_samp : number of samples to take at 36kHz rate
139 !Fb : filter bandwidth
140 !N : INT(Sf/fb)
141 !Ns :INT (Num_samples/4)
142 !Br( ) : array, sampled data, red
143 !Bl( ) : array, sampled data, blue
144 !If1 : interpolation factor for f1
145 !If2 : interpolation factor for f2
146 !F1( ) : convolution multiplying function for f1
147 !F2( ) : convolution multiplying function for f2
148 !Start : starting point, determined by N
149 !Qr : starting sampled data point for next K1
150 !interval, including doppler correction, red.
151 !Qb : same as Qr except, blue
152 !Xx : Xx-1, loop for red;Xx-2 loop for blue
153 !B1( ) : spare input
154 !B2( ) : spare input
155 !Filt_f1(J) : convolution elements in K1 interval, f1
156 !Filt_f2(J) : convolution elements in K1 interval, f2
157 !B1(P) : average of B1( ) in K1 interval
158 !B2(P) : average of B2( ) in k2 interval
159 !P : K1 interval of computation
160 !Ror : running sum of doppler correction, red
161 !Rob : running sum of doppler correction, blue
162 !Rotr(P) : running sum stored as a function of P
163 !Rotb(P) : running sum stored as a function of P
164 !OCCR(P) : doppler correction for respective K1 interval, red
165 !OCCB(P) : doppler correction for respective K1 interval, blue
166 !Qpsr : quadrant past, red
167 !Qpsb : quadrant past, blue
168 !Qptr : quadrant present, red
169 !Qptb : quadrant present, blue
170 !Qsr : running sum of quadrants, red
171 !Qsb : running sum of quadrants, blue
172 !Tar : total angle red, K1 interval
173 !Tab : total angle blue, K1 interval
174 !Ta_red(P) : total angle red, P K1 interval
175 !Ta_bl(P) : total angle blue, P K1 interval
176 !Whole quadrant update table

```

```

180 DIM Q(5,4)
181 Q(1,2)=1
182 Q(1,4)=1
183 Q(2,1)=1
184 Q(2,3)=1
185 Q(3,2)=1
186 Q(3,4)=1
187 Q(4,1)=1
188 Q(4,3)=1
189 Qsr=10 !Quadrant sum red starts at 10
190 Qsb=10 !Quadrant sum blue starts at 10
191 ASSIGN @Gpio TO 12
192 !PRINT " REGISTER STATUS BEFORE DMA"
193 !GOSUB Check_stat
194 !:-----:
195 Main: ! Main program
196 !
197 PRINT CHR$(12)
198 GOSUB A_to_d_reset
199 GOSUB Range_stored
200 BEEP
201 GOSUB Mult_fun !Generate multiplier
202 !functions.
203 BEEP
204 GOSUB Comp_angle !Convolution, envelop detection, doppler correction,
205 !& Arctan for red and blue
206 DISP
207 GOSUB Disp_out
208 GOTO 1
209 !:-----:
210 Range_stored: !
211 !
212 -----
213 INPUT "RANGE DATA, Type R/r : STORED DATA?, Type S/s",Aa$
214 IF Aa$="R" OR Aa$="r" THEN
215 GOSUB Num_samp
216 !GOSUB Dma_transfer
217 GOSUB Test_data
218 GOSUB File_data
219 GOSUB Buffer_array
220 GOSUB Filt_bw_int
221 GOSUB Filt_bw_int
222 RETURN
223 END IF
224 IF Aa$="S" OR Aa$="s" THEN
225 GOSUB File_array
226 GOSUB Buffer_array
227 GOSUB Filt_bw_int
228 RETURN
229 END IF
230 BEEP
231 BEEP
232 BEEP
233 GOTO 213
234 !:-----:
235 Num_samp: !Input the total number of samples
236 !
237 -----
238 !to be taken. Maximum of 32K
239 BEEP
240 INPUT "TOTAL NUMBER OF SAMPLES TO BE TAKEN?",Num_samples
241 REPEAT (Num_samples/4),INTEGER B1(0:Ns)
242 ALLOCATE INTEGER B1(0:Ns),INTEGER B2(0:Ns)

```

```

243 ALLOCATE INTEGER Rotr(0:Ns),Rotb(0:Ns),Qccr(0:Ns),Qccb(0:Ns)
245 ALLOCATE REAL Ta_red(INT(Num_samples/K1)),Ta_b1(INT(Num_samples/K1)),Rot(I
NT(Num_samples/K1))
246 !Create an un-named buffer so greater than
247 !32k can be collected.
248 ASSIGN @Buffer TO BUFFER [Num_samples]
249 RETURN
250 Dma_transfer:!
251 CONTROL @Buffer,4;0
252 CONTROL Gpio,0;2
253 CONTROL Gpio,3;0
254 ISET TRANSFER LOW
255 CONTROL Gpio,2;3 !SET CLTO TO 0, XFER 0
256 BEEP
257 DISP "          WAITING FOR RANGE TRIGGER"
258 TRANSFER @Gpio TO @Buffer;COUNT Num_samples
259 CONTROL Gpio,2;2 !SET CLTO & CLT1 TO 1
260 CONTROL Gpio,1;3
261 !PRINT "          REGISTER STATUS AFTER DMA"
262 !GOSUB Check_stat
263 BEEP
264 RETURN
265 Filt_bw_int:!Input filter bandwidth in hertz
266 BEEP
267 INPUT "WHAT IS THE DESIRED FILTER BANDWIDTH IN HERTZ?",Fb
268 N=INT(Sf/Fb)
269 PRINT CHR$(12)
270 BEEP
271 INPUT "Real samples f1=12. interpolation factor?",If1
272 BEEP
273 INPUT "Real samples f2=6. interpolation factor?",If2
274 BEEP
275 ALLOCATE REAL Filt_f1(1:K1*If1),Filt_f2(1:K1*If2)
276 RETURN
277 Test:! Generate data - needs to be modified for this
278 !program
279 BEEP
280 INPUT "What is the Envelop Peak Amplitude?",Epa
281 BEEP
282 DISP "          GENERATING DATA"
283 Peak_value_data=0
284 Gal_cyc_frg=200
285 Ab=0
286 ALLOCATE INTEGER Mmm(0:Num_samples-1)
287 FOR X=0 TO Num_samples-1 STEP 4
288   Ac=Epa*SIN((PI*(+Ab))/(6*Gal_cyc_frg)+(2.7)*SIN(2*PI*Ab*Gf/Sf))
289   FOR Y=X TO X+3
290     Mmm(Y)=INT(Ac)+128
291     !PRINT Y,Mmm(Y)
292     OUTPUT @Buffer USING "#,B";Mmm(Y)
293   NEXT Y
294   Ab=Ab+1
295 NEXT X
296 DISP
298 WAIT 5
299 RETURN
300 !:::::::::::::::::::::::::::::::::::::::::::
301 Mult_fun: !Generation of the multiplying function.
302 !
303 !Multiplying function will be (SIN(X)/(X))*COS(Y)
304 !PRINTER IS 705

```

```

305 !ALLOCATE REAL F1(0:(N*If1)),REAL F2(0:(N*If2))
306 DIM F1(0:2000),F2(0:2000)
307 RAD
308 BEEP
309 !Generate 1/2 multiplier function for F1
310 BEEP
311 DISP "Building multiplier function for F1"
312 F1(0)=1
313 !PRINT "F1(0)=";F1(0)
314 FOR P=1 TO N*If1
315 Aa=(PI*P)/(N*If1)
316 Bb=(Aa*2*Gf)/Fb
317 !PRINT "P=";P
318 !PRINT "N=";N*If1
319 !PRINT "(PI*P)/N=";Aa
320 !PRINT "(Aa*2*GF)/FB=";Bb
321 F1(P)=(SIN(Aa)/Aa)*COS(Bb)
322 !PRINT "F1(";P;")=";F1(P)
323 NEXT P
324 DISP "Building multiplier function for F2"
325 !Generate 1/2 of multiplier function for F2
326 F2(0)=1
327 !PRINT "F2(0)=";F2(0)
328 FOR P=1 TO N*If2
329 Aa=(PI*P)/(N*If2)
330 Bb=(Aa*4*Gf)/Fb
331 !PRINT "P=";P
332 !PRINT "N=";N
333 !PRINT "(PI*P)/N=";Aa
334 !PRINT "(Aa*4*GF)/FB=";Bb
335 F2(P)=(SIN(Aa)/Aa)*COS(Bb)
336 !PRINT "F2(";P;")=";F2(P)
337 NEXT P
338 RETURN
339 !
340 !.....
341 !Convolution and envelop detection
342 !at K1 intervals for f1 and f2.
343 !.....
344 !.....:
345 Comp_angle:!Filter, envelop detection,
346 !doppler correction and
347 !arctan for red & blue
348 !
349 !-----
350 !
351 RAD
352 Tot_angle_peak=0
353 P=0 !Initialization of array for the out-
354 !put angle for red and blue lasers.
355 !Determine first data point to start con-
356 !volution considering the value of N and
357 !the need of a + slope for f1 for synchr-
358 !onization.
359 Quotient=(N+1) DIV K1
360 Start=(Quotient+1)*12
361 BEEP
362 DISP " CRUNCHING DATA"
363 PRINT "Start=";Start
364 Qa=0 !Initialize graph index. Increment
365 Qr=Start+2+Sys_del_red !Qa for each 200 computations
366 Qb=Start+2+Sys_del_bl

```



```

372 FOR Xx=1 TO 2 !1=red,2=blue
374 IF Xx=1 THEN
375 Q=Qr
376 ELSE
377 Q=Qb
378 END IF
379 !::::::::::::::::::::::::::::::::::::::::::
380 Con_f1:!
381 !Convolution over K1 interval for
382 !f1
383 !
384 J=1
385 Peak_value_f1=0
388 FOR X=Q TO Q+K1-1
392 FOR C=0 TO If1-1
393 Sum_f1=0
394 IF Xx=1 THEN !Xx=1,Red:Xx=2,Blue
395 FOR M=X TO X+N
396 Product_f1=Br(M+1)*F1((M-X)*If1-C+If1)+Br(2*X-M)*F1((M-X)*If1+C)
397 Sum_f1=Sum_f1+Product_f1
398 ! PRINT Q;TAB(10);X;TAB(20);C;TAB(30);M;TAB(40);J;TAB(45);((M-X)*
If1+C);
399 ! PRINT TAB(50);((M-X)*If1-C+If1);
400 ! PRINT TAB(60);(2*X-M-1)
401 NEXT M
402 ELSE
403 FOR M=X TO X+N
404 Product_f1=B1(M+1)*F1((M-X)*If1-C+If1)+B1(2*X-M)*F1((M-X)*If1+C)
405 Sum_f1=Sum_f1+Product_f1
406 ! PRINT Q;TAB(10);X;TAB(20);C;TAB(30);M;TAB(40);J;TAB(45);((M-X)
+If1+C);
407 ! PRINT TAB(50);((M-X)*If1-C+If1);
408 ! PRINT TAB(60);(2*X-M-1)
409 NEXT M
410 END IF
411 Filt_f1(J)=Sum_f1
413 !PRINTER IS 705
414 !PRINT "Filt_f1(";J;"=");Filt_f1(J)
417 !PRINTER IS 1
418 IF ABS(Filt_f1(J))>Peak_value_f1 THEN
419 Peak_value_f1=ABS(Filt_f1(J))
420 END IF
421 J=J+1
422 NEXT C
423 NEXT X
424 !::::::::::::::::::::::::::::::::::::::::::
425 Env_f1!!Envelop detection over K1
426 !interval for f1
427 !
428 Diff_plus_f1=0
429 Diff_minus_f1=0
430 FOR E=If1+1 TO 5*If1+1
431 Diff_f1=Filt_f1(E)-Filt_f1(E+INT(If1*K1/2))
432 IF Diff_f1>Diff_plus_f1 THEN
433 Diff_plus_f1=Diff_f1
434 END IF
435 IF Diff_f1<Diff_minus_f1 THEN
436 Diff_minus_f1=Diff_f1
437 END IF
438 !PRINT "e=";E;"Diff_f1=";Diff_f1
439 !PRINT "Diff_plus_f1=";Diff_plus_f1

```

```

440         !PRINT "Diff_minus_f1=";Diff_minus_f1
441     NEXT E
442     !Value of Envelop at P interval for f1
443     IF Diff_plus_f1>ABS(Diff_minus_f1) THEN
444         Envelop_f1=Diff_plus_f1
445     ELSE
446         Envelop_f1=Diff_minus_f1
447     END IF
448     !::::::::::::::::::::::::::::::::::::::::::::::::::
449     Con_f2:!
450         !Convolution over K1 interval for F2
451     !-----
452         J=1
453         Peak_value_f2=0
454         FOR X=Q TO Q+K2-1
455             FOR C=0 TO If2-1
456                 Sum_f2=0
457                 IF X=1 THEN !Xx=1,Red:Xx=2,Blue
458                     FOR M=X TO X+N
459                         Product_f2=Br(M+1)*F2((M-X)*If2-C+If2)+Br(2*X-M)*F2((M-X)*If2+C)
460                         Sum_f2=Sum_f2+Product_f2
461                         ! PRINT Q;TAB(10);X;TAB(20);C;TAB(30);M;TAB(40);J;TAB(45);((M-X)
+If2+C);
462                         ! PRINT TAB(50);((M-X)*If2-C+If2);
463                         ! PRINT TAB(60);(2*X-M-1)
464                     NEXT M
465                 ELSE
466                     FOR M=X TO X+N
467                         Product_f2=B1(M+1)*F2((M-X)*If2-C+If2)+B1(2*X-M)*F2((M-X)*If2+C)
468                         Sum_f2=Sum_f2+Product_f2
469                         ! PRINT Q;TAB(10);X;TAB(20);C;TAB(30);M;TAB(40);J;TAB(45);((M-X)
+If2+C);
470                         ! PRINT TAB(50);((M-X)*If2-C+If2);
471                         ! PRINT TAB(60);(2*X-M-1)
472                 ... NEXT M
473                 END IF
474                 Filt_f2(J)=Sum_f2
475                 !PRINTER IS 705
476                 !PRINT "Filt_f2(";J;"=");Filt_f2(J)
477                 !PRINTER IS 1
478                 IF ABS(Filt_f2(J))>Peak_value_f2 THEN
479                     Peak_value_f2=ABS(Filt_f2(J))
480                 END IF
481                 J=J+1
482             NEXT C
483         NEXT X
484     !::::::::::::::::::::::::::::::::::::::::::::::::::
485     Env_f2:!Envelop detection over fract-
486         !ional interval of K1 for f2
487         !using 1/2 cycle difference
488     !-----
489         Diff_plus_f2=0
490         Diff_minus_f2=0
491         FOR E=If2+1 TO 5*If2+1
492             Diff_f2=Filt_f2(E)-Filt_f2(E+3*If2)
493             IF Diff_f2>Diff_plus_f2 THEN
494                 Diff_plus_f2=Diff_f2
495             END IF
496             IF Diff_f2<Diff_minus_f2 THEN
497                 Diff_minus_f2=Diff_f2
498             END IF
499

```

```

500     NEXT E
501     !Value of Envelop at P interval for f2
502     IF Diff_plus_f2>ABS(Diff_minus_f2) THEN      r
503         Envelop_f2=Diff_plus_f2
504     ELSE
505         Envelop_f2=Diff_minus_f2
506     END IF
507     !PRINT "Envelop_f2";Envelop_f2
510     !::::::::::::::::::::::::::::::::::::::::::::::::::
511     Doppler_cor:
512     !
513     !.....
514     ! CORRECTION FOR THE DOPPLER EFFECT FOR RED
515     !          AND BLUE
516     !.....
517     IF ABS(Envelop_f1)>ABS(Envelop_f2) THEN
518         FOR E=If1+1 TO 5*If1+1
519             D2=Filt_f1(E+2)-Filt_f1(E+1)
520             D1=Filt_f1(E+1)-Filt_f1(E)
521             !PRINT "D2=";D2,"D1=";D1,"(D2-D1)=";D2-D1,"E=";E
522             IF D2=0 OR SGN(D1)+SGN(D2)=0 THEN
523                 GOTO 526
524             END IF
525         NEXT E
526         Dsq=D2-D1
527         Ap=Filt_f1(E)
528         Bp=D1-Dsq/2
529         Cp=Dsq/2
530         Envelop_f11=(Ap-(Bp^2))/(4*Cp)
531         !PRINT "Envelop_f11=";Envelop_f11
532         Ee=E-Bp/(2*Cp)
533         !PRINTER IS 705
534         !!!! PRINT "Ee_f1=";Ee
535         PRINTER IS 1
536         Qc=0
537         IF Ee>4*If1+1 THEN Qc=-1
538         IF Ee<2*If1-1 THEN Qc=+1
539     ELSE
540         FOR E=If2+1 TO 5*If2+1
541             D2=Filt_f2(E+2)-Filt_f2(E+1)
542             D1=Filt_f2(E+1)-Filt_f2(E)
543             !PRINT "D2=";D2,"D1=";D1,"(D2-D1)=";D2-D1,"E=";E
544             IF D2=0 OR SGN(D1)+SGN(D2)=0 THEN
545                 GOTO 548
546             END IF
547         NEXT E
548         Dsq=D2-D1
549         Ap=Filt_f2(E)
550         Bp=D1-Dsq/2
551         Cp=Dsq/2
552         Envelop_f22=(Ap-(Bp^2))/(4*Cp)
553         !PRINT "Envelop_f22=";Envelop_f22
554         Ee=E-Bp/(2*Cp)
555         !PRINTER IS 705
556         !!!! PRINT "Ee_f2=";Ee
557         PRINTER IS 1
558         Qc=0
559         IF Ee>4*If2+1 THEN Qc=-1
560         IF Ee<2*If2-1 THEN Qc=+1
561     END IF
562     IF Xx=1 THEN

```

```

563      Ror=Ror+Qc
564      !!!! PRINT "Ror=";Ror,
565      Rotr(P)=Ror
566      Qccr(P)=Qc
567      !PRINTER IS 705
568      !!!! PRINT "Qc=";Qc
569      PRINTER IS 1
570      Qr=Qr+Qc+K1
571      !!!! PRINT "Qr=";Qr
572      ELSE
573      Rob=Rob+Qc
574      !!!! PRINT "Rob=";Rob
575      Rotb(P)=Rob
576      Qccb(P)=Qc
577      !PRINTER IS 705
578      !!!! PRINT "Qc=";Qc
579      PRINTER IS 1
580      Qb=Qb+Qc+K1
581      !!!! PRINT "Qb=";Qb
582      PRINT
583      END IF
584      E_f1=Envelop_f1
585      E_f2=Envelop_f2
586      !!!!PRINT "Envelop_f2/Envelop_f1=";Envelop_f2/Envelop_f1
587      !:::::::::::::::::::::::::::::::::::::::::::::::::::::::::::
588      Arc_t:!Computation of the angle from the
589           !arctan(Envelop_f2/Envelop_F1) and
590           !counting of the whole quadrants
591      !

---

592      BEEP 500,.2
593      PRINTER IS 1
594      DEG
595      IF Xx=1 THEN ! Arc_t for Red laser
596      IF E_f1=0 THEN !Take care of divide by zero
597      IF Qpsr=1 OR Qpsr=3 THEN
598          Tar=(Qsr)*90+90
599          GOTO 634
600      ELSE
601          Tar=(Qsr)*90
602          GOTO 634
603      END IF
604      END IF
605      Ra=E_f2/E_f1
606      !PRINTER IS 705
607      !!!! PRINT Ra
608      PRINTER IS 1
609      !Determine Quadrant & Total_angle(P)_
610      IF ABS(Ra)>=60 THEN
611          IF SGN(Ra)=1 THEN
612              Ra=60
613          ELSE
614              Ra=-60
615          END IF
616      END IF
617      IF SGN(Ra)=1 THEN !Plus Ratio
618      IF SGN(E_f1)=1 THEN ! Deno plus
619          Qptr=1
620      ELSE
621          Qptr=3
622      END IF
623      Tar=(Qt(Qpsr,Qptr)+Qsr)*90+ATN(Ra)-900

```

```

624     ELSE
625         IF SGN(E_f1)=1 THEN
626             Qptr=4
627         ELSE
628             Qptr=2
629         END IF
630         Tar=(Qt(Qpsr,Qptr)+Qsr)*90+90+ATN(Ra)-900
631     END IF
632     Qsr=Qt(Qpsr,Qptr)+Qsr
633     IF P>1 THEN Qpsr=Qptr
634     !PRINTER IS 705
635     !!!! PRINT P,PROUND(Tar,-2),Qpsr,Qptr,B1(Q),B1(P)
636     PRINTER IS 1
637     PRINT
638     Ta_red(P)=Tar
639     !!!! PRINT P,"Ta_red=";PROUND(Ta_red(P),-2),"E_F1=";E_f1,"E_F2=";E_f2
640     PRINTER IS 1
641     ELSE!Arc_t for blue laser
642     IF E_f1=0 THEN !Take care of divide by zero
643         IF Qpsb=1 OR Qpsb=3 THEN
644             Tab=(Qsb)*90+90
645             GOTO 679
646         ELSE
647             Tab=(Qsb)*90
648             GOTO 679
649         END IF
650     END IF
651     Ra=E_f2/E_f1
652     !Determine Quadrant & Total_angle(P)_
653     IF ABS(Ra)>=60 THEN
654         IF SGN(Ra)=1 THEN
655             Ra=60
656         ELSE
657             Ra=-60
658         END IF
659     END IF
660     IF SGN(Ra)=1 THEN !Plus Ratio
661         IF SGN(E_f1)=1 THEN ! Deno plus
662             Qptb=1
663         ELSE
664             Qptb=3
665         END IF
666         Tab=(Qt(Qpsb,Qptb)+Qsb)*90+ATN(Ra)-900
667     ELSE
668         IF SGN(E_f1)=1 THEN
669             Qptb=4
670         ELSE
671             Qptb=2
672         END IF
673         Tab=(Qt(Qpsb,Qptb)+Qsb)*90+90+ATN(Ra)-900
674     END IF
675     Qsb=Qt(Qpsb,Qptb)+Qsb
676     IF P>1 THEN Qpsb=Qptb
677     !PRINTER IS 705
678     PRINT
679     !!!! PRINT P,PROUND(Tab,-2),Qpsb,Qptb,B1(Q),B1(P)
680     PRINTER IS 1
681     Ta_bl(P)=Tab
682     !!!! PRINT P,"Ta_bl=";PROUND(Ta_bl(P),-2),"E_F1=";E_f1,"E_F2=";E_f2
683     END IF!For red or blue
684     PRINTER IS 1

```

```

689 RAD
690 NEXT Xx
691 RAD
692 PRINT
693 !This completes the angle computation
694 !for the red and blue for this K1 interval P
695 P=P+1
696 PRINT P
698 !Test to increment Qq or not
699 IF P=0 THEN
700 Qq=0
701 ELSE
702 Rmdr=P MOD 199 !P starts at 0
703 IF Rmdr=0 THEN Qq=Qq+1
704 END IF
705 !Q>Ns-48, either red/blue will exit to Main
706 IF Q>=Ns-48 THEN RETURN
707 GOTO 372
708 Disp_out:!Graph data
709 DUMP DEVICE IS 705
710 PRINTER IS 705
711 PEN 2
712 !!PRINT CHR$(12); !Clear alpha & form feed
713 DISP
714 GINIT !Initialize
715 GRAPHICS ON !Raster on
716 FOR Qqq=0 TO Qq !Graph index
717 FOR R=1 TO 2 !red=1, blue=2
718 PEN 2
719 WINDOW -7,50,-500,500 !Set window
720 AXES 10,100
721 LORG 6
722 FOR I=0 TO 50 STEP 10
723 MOVE I,0
724 LABEL Qqq*200+I
725 NEXT I
726 !
727 LORG 8
728 FOR I=-400 TO 400 STEP 100
729 MOVE 0,I
730 LABEL I
731 NEXT I
732 !
733 LORG 5
734 MOVE 25,475
735 PEN 6
736 LABEL "ANGLE AS A FUNCTION OF ENVELOP SAMPLES"
737 MOVE 18,425
738 IF R=1 THEN
739 PEN 2
740 LABEL "RED"
741 MOVE 18,-400
742 LABEL Name$
743 PEN 6
744 END IF
745 IF R=2 THEN LABEL "BLUE"
746 MOVE 18,-400
747 LABEL Name$
748 MOVE -4,0
749 LORG 6
750

```

```

751 LABEL "Samp"
752 LOG 5
753 MOVE 25,-475
754 LABEL Title$:"ENVELOP SAMPLE RATE, 3KHZ"
755 PEN 0
756 MOVE 0,0
757 PEN 2
758 FOR X=0 TO 50 !graph data
759 IF R=1 THEN
760 Tb=Ta_red(Qqq*200+X+4)-Ta_red(4)
761 ELSE
762 Tb=Ta_bl(Qqq*200+X+4)-Ta_bl(4)
763 END IF
764 DRAW X,Tb
765 NEXT X
766 PEN 0
767 MOVE 0,0
768 PEN 0
769 PAUSE
770 !DUMP GRAPHICS
771 !PRINT CHR$(12)
772 GCLEAR
773 NEXT R
774 NEXT Qqq
775 ALPHA ON
776 PRINTER IS 1
777 DISP "PAUSE"
778 PAUSE
779 RETURN
780 !::::::::::::::::::::::::::::::::::::::::::::::::::
781 Err_rout: !Routines for error recovery
782 !
783 BEEP
784 BEEP
785 BEEP
786 DISP ERRMS
787 PAUSE
788 GOSUB Disp_out
789 PAUSE
790 !::::::::::::::::::::::::::::::::::::::::::::::::::
791 Buffer_array:!Transfer of data from buffer to array.
792 !
793 PRINT CHR$(12)
794 DISP "TRANSFERRING DATA FROM BUFFER TO 4 ARRAYS"
795 CONTROL @Buffer,5;1
796 FOR X=1 TO Ns-1
797 ENTER @Buffer USING "#.B";Zzz
798 Br(X-1)=Zzz-128
799 ENTER @Buffer USING "#.B";Zzz
800 B1(X-1)=Zzz-128
801 ENTER @Buffer USING "#,B";Zzz
802 B1(X-1)=Zzz-128
803 ENTER @Buffer USING "#.B";Zzz
804 B2(X-1)=Zzz-128
805 !PRINT X-1,Br(X-1),B1(X-1),B1(X-1),B2(X-1)
806 NEXT X
807 DISP "TRANSFER COMPLETE"
808 WAIT 2
809 PRINT CHR$(12)
810 RETURN
911 !::::::::::::::::::::::::::::::::::::::::::::::::::

```

```

812 File_data: !Transfer of data from Buffer
813             !to disk
814 !-----
815 BEEP
816 DISP "INSERT A FORMATTED DATA DISK! - PRESS CONT TO CONT"
817 PAUSE
818 INPUT "NAME OF DATA FILE TO BE CREATED?",Name$
819 IF Name$="" THEN 818
820 BEEP
821 DISP "CREATING A DATA FILE"
822     !Record length is 1
823 CREATE BDAT Name$&":INTERNAL",Num_samples,1
824     !Assign an I/O path
825 ASSIGN @File TO Name$&":INTERNAL"
826 PRINT CHR$(12)
827 DISP "TRANSFERRING DATA FROM BUFFER TO FILE"
828 TRANSFER @Buffer TO @File;COUNT Num_samples
829 WAIT 5
830 DISP "TRANSFER COMPLETE"
831 WAIT 5
832 DISP
833 RETURN
834 !::::::::::::::::::::::::::::::::::::::::::::::::::::::::::
835 File_array: !Transfer from file to array
836 !-----
837 BEEP
838 PRINT CHR$(12)
839 DISP "INSERT DATA DISK -- PRESS CONT TO CONT"
840 PAUSE
841 CAT
842 BEEP
843 INPUT "WHAT FILE?",Name$
844 INPUT "Rec/File for file?",Num_samples
845 GOSUB 240
846 ASSIGN @File TO Name$&":INTERNAL"
847     !Reset file pointer to 1
848 CONTROL @File,5;1
849     !Reset buffer pointer to 1
850 CONTROL @Buffer,5;1
851 DISP "TRANSFERRING FROM DATA FILE TO BUFFER ARRAY"
852 TRANSFER @File TO @Buffer;COUNT Num_samples
853 DISP "TRANSFER COMPLETED"
854     !Reset buffer pointer to 1
855 CONTROL @Buffer,5;1
856     !Close @file
857 ASSIGN @File TO *
858 WAIT 2
859 PRINT CHR$(12)
860 DISP
861 RETURN
862 !::::::::::::::::::::::::::::::::::::::::::::::::::::::::::
863 A_to_d_reset: !
864 !-----
865 !RESET DATA TRANSFER ELECTRONICS
866 CONTROL Gpio,2;2 !SET CTLO & CTL1 TO 0
867 CONTROL Gpio,2;0 !SET CTLO TO 1 & CTL1 TO 0
868 CONTROL Gpio,2;2 !SET CTLO & CTL1 TO 1
869 !END RESET
870 RETURN
871 !::::::::::::::::::::::::::::::::::::::::::::::::::::::::::
1180 Test_data: ! Generate test data

```



```

1181
1182     !PRINTER IS 705
1183     PRINT CHR$(12)
1184     DISP
1185     BEEP
1186     INPUT "What is the Envelop Peak Amplitude?".Epa
1187     BEEP
1188     DISP "                GENERATING DATA"
1189     Peak_value_data=0
1190     Gal_cyc_frg=200
1191     Ab=0
1192     ALLOCATE INTEGER Mmm(0:Ns*4-1)
1193     FOR X=0 TO Ns*4-1 STEP 4
1194         Ac=Epa*SIN((PI*(X+Ab))/(6*Gal_cyc_frg)+2.7*SIN(2*PI*Ab*Gf/S))
1195         FOR Y=X TO X+3
1196             Mmm(Y)=INT(Ac)+128
1197             !PRINT Y,Mmm(Y)
1198             OUTPUT @Buffer USING "0,B":Mmm(Y)
1199         NEXT Y
1200     NEXT X
1201     Ab=Ab+1
1202     NEXT X
1203     DISP
1204     RETURN
1205     END

```

Cross Reference <<<<

Number	Variable								
	h_to_d_reset								
	ha	315	316	321	329	330	335		
	hb	285	288	294	1193	1196	1204		
	hc	288	290	1196	1200				
	hd	527	530	549	552				
	he	242	802						
	h_pea1								
	h_pea2	242	804						
	h_pea3								
	h_pea4								
	hb	316	321	330	335				
	hbb								
	hbb								
	hbb								
	hbb	241	404	467	800				
	hbc	526	530	532	550	552	554		
	hbr	241	396	459	798				
	butter_array								
	bu_label								
	bu	392	396	404	422	455	459	467	482
	Check_stat								
	Check_stat_r								
	Comp_angle								
	con_f2								
	cp	529	530	532	551	552	554		
	csbf1								
	csbf2								
	csrf1								
	csrf2								
	d1	520	522	526	528	542	544	548	550
	d2	519	522	526	541	544	546		
	Diff_f1	431	432	433	435	436			
	Diff_f2	493	494	495	497	498			
	Diff_minus_f1	429	435	436	443	446			
	Diff_minus_f2	490	497	498	502	505			
	Diff_plus_f1	428	432	433	443	444			
	Diff_plus_f2	489	494	495	502	503			
	Disp_con								
	Disp_data								
	Disp_data_1								
	Disp_data_2								
	Disp_out								
	Dma_transfer								
	Dpcb								
	Dpcr								
	Ds	550							
	Dsq	526	528	529	540	551			
	E	430	431	441	492	493	500	518	519
	E	527	532	540	541	542	547	549	554
	E_f1	584	596	605	618	625	644	653	663
	E_f2	585	605	653					
	ee	532	537	538	554	559	560		
	Endcat								
	Envelop_f1	444	446	517	584				
	Envelop_f11	530							
	Envelop_f2	503	505	517	585				

AD-A179 742

LASER BALLISTIC SENSOR DEVELOPMENT(U) BOEING AEROSPACE
CO SEATTLE WA C R POND ET AL JAN 87 BRL-CR-563
DAAK11-84-C-0095

2/2

UNCLASSIFIED

F/G 9/3

NL



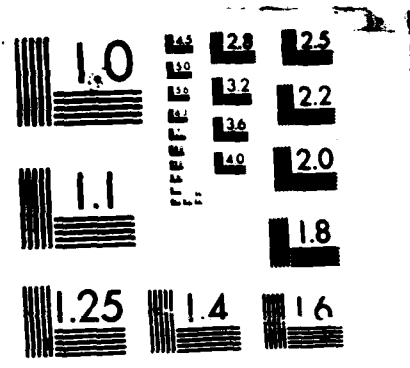

MICROCOPY RESOLUTION TEST CHART
NATIONAL BUREAU OF STANDARDS 1963 A

Envelop_f22	552										
Epa	280	288	1188	1196							
Err_rout											
F1	306	<-DEF	312	321	396	404					
F2	306	<-DEF	326	335	459	467					
Fb	267	268	316	330							
File_array											
File_data											
Filt_bw_int											
Filt_f1	275	411	418	419	431	519	520	527			
Filt_f11b											
Filt_f11r											
Filt_f1b											
Filt_f1r											
Filt_f2	275	474	478	479	493	541	542	549			
Filt_f22b											
Filt_f22r											
Filt_f2b											
Filt_f2r											
Gal_cyc_frg	284	288	1192	1196							
Gf	127	288	316	330	1196						
Gpio	119	252	253	255	259	260	866	867	868		
Hp1b	120										
I	722	723	724	725	728	729	730	731			
If1	271	275	314	315	392	396	404	430	431	518	
	537	538									
If2	273	275	328	329	455	459	467	492	493	540	
	559	560									
J	384	411	418	419	421	452	474	478	479	481	
J1	128	245	275	360	388	431	570	580			
K2	129	454									
K3	130										
Kk											
M	395	396	401	403	404	409	458	459	464	466	
	467	472									
Max_x_axes											
Mmm	286	290	292	1194	1200	1202					
Mn											
Mult_fun											
N	268	314	315	328	329	360	395	403	458	466	
Nnn											
Ns	240	241	242	243	706	796	1194	1195			
Num_samp											
Num_samples	239	240	245	248	258	286	287	823	828	844	
	852										
Op											
	314	315	321	323	328	329	335	337	354	565	
	566	575	576	633	639	678	685	695	696	699	
	702										
Peak_value_data	283	1191									
Peak_value_f1	385	418	419								
Peak_value_f11b											
Peak_value_f11r											
Peak_value_f1b											
Peak_value_f1r											
Peak_value_f2	453	478	479								
Peak_value_f22b											
Peak_value_f22r											
Peak_value_f2b											
Peak_value_f2r											
Product_f1	396	397	404	405							

Product_f2	459	460	467	468						
Q	375	377	388	454	706					
Qb	371	377	580							
Qc	536	537	538	558	559	560	563	566	570	573
	576	580								
Qccb	243	576								
Qccr	243	566								
Qj										
Qpsb	645	668	675	677	678					
Qpsr	597	623	630	632	633					
Qptb	664	666	668	671	673	675	677	678		
Qptr	619	621	623	626	628	630	632	633		
Qq	365	700	703	716						
Qqq	716	724	760	762	774					
Qr	370	375	570							
Qsb	190	646	649	668	675	677				
Qsr	189	598	601	623	630	632				
Qt	180	<-DEF	181	182	183	184	185	186	187	188
	623	630	632	668	675	677				
Quotient	360	361								
R	717	738	745	759	773					
Ra	605	610	611	612	614	617	623	630	653	655
	656	657	659	662	668	675				
Range_stored										
Rmdr	702	703								
Rob	573	575								
Ror	563	565								
Rot	245									
Rotb	243	575								
Rotr	243	565								
S										
Sf	126	268	288	1196						
Ssp										
Start	361	364	370	371						
Sum_f1	393	397	405	411						
Sum_f2	456	460	468	474						
Sys_del_bl	134	371								
Sys_del_red	131	370								
Ta_bl	245	685	762							
Ta_red	245	639	760							
Tab	646	649	668	675	685					
Tar	598	601	623	630	639					
Tb	760	762	764							
Test_data										
Tic_m_x										
Tot_angle_peak	353									
Tt										
X	287	289	295	388	395	396	403	404	423	454
	458	459	466	467	483	758	760	762	764	765
	796	798	800	802	804	806	1195	1199	1205	
Xx	372	374	394	457	562	595	690			
Y	289	290	292	293	1199	1200	1202	1203		
Z										
Zzz	797	798	799	800	801	802	803	804		
+ String Variables										
Aa\$	213	214	224							
Names\$	742	747	818	819	823	825	843	846		
Title\$	754									
+ I/O Path Names										

@Buf										
@Buffer	248	251	258	292	795	797	799	801	803	828
	850	852	855	1202						
@File	825	828	846	848	852	857				
@Gpio	191	258								

+ Line Labels

A_to_d_reset	198	863	<-DEF		
Arc_t	588	<-DEF			
Buffer_array	220	226	791	<-DEF	
Bw_label					
Check_stat					
Check_stat_r					
Comments		11	<-DEF		
Comp_angle	204	345	<-DEF		
Con_f1	380	<-DEF			
Con_f2	449	<-DEF			
Constants	123	<-DEF			
Disp_con					
Disp_data					
Disp_data_1					
Disp_data_2					
Disp_out	117	207	708	<-DEF	788
Dma_transfer	250	<-DEF			
Doppler_cor	511	<-DEF			
Env_f1	425	<-DEF			
Env_f2	485	<-DEF			
Err_rout	113	781	<-DEF		
File_array	225	835	<-DEF		
File_data	219	812	<-DEF		
Filt_bw_int	221	227	265	<-DEF	
Index	81	<-DEF			
Initialize	109	<-DEF			
Main	195	<-DEF			
Mult_fun	201	301	<-DEF		
Num_samp	215	235	<-DEF		
Range_stored	199	210	<-DEF		
Test	277	<-DEF			
Test_data	217	1180	<-DEF		
Var_list	139	<-DEF			

* Line Numbers

1	208
4	
5	
9	
11	
13	
17	
24	
157	
174	
180	
188	
194	
196	
202	
213	233
214	
220	
221	

226		
240	845	
245		
249		
363		
372	707	
390		
524		
526	523	
540		
546		
548	545	
562		
571		
578		
600		
626		
634	599	602
635		
648		
679	647	650
686		
691		
716		
729		
736		
763		
816		
818	819	
820		
827		
830		
858		
884		
895		
902		
907		
911		
951		
1254		
1274		

* SUB Subprograms
Endcat

Unused entries = 3

REFERENCES

1. Crowder, J. P., Hill, E. G., and Pond, C. R., "Selected Wind Tunnel Testing Developments at the Boeing Aerodynamics Laboratory", AIAA Paper 80-0458, March 1980.
2. Pond, C. R. and Texeira, P. D., "Laser Ballistic Sensor Development", ARBRL-CR-00526, U. S. Army Ballistic Research Laboratory, Aberdeen Proving Ground, MD, March 1984.
3. Wolfe, Wm. L., and Zissis, G. J., The Infrared Handbook, Environmental Research Institute of Michigan, Ann Arbor MI, 1978.

DISTRIBUTION LIST

<u>No. of Copies</u>	<u>No. of Organization</u>	<u>Copies</u>	<u>Organization</u>
12	Administrator Defense Technical Info Center ATTN: DTIC-FDAC Cameron Station, Bldg. 5 Alexandria, VA 22304-6145	1	Commander US Army Aviation Systems Command ATTN: AMSAV-ES 4300 Goodfellow Boulevard St. Louis, MO 63120-1798
1	Commander US Army Materiel Command ATTN: AMCDRA-ST 5001 Eisenhower Avenue Alexandria, VA 22333-0001	1	Director US Army Aviation Research and Technology Activity Ames Research Center Moffett Field, CA 94035-1099
1	Commander US Army Materiel Command ATTN: AMCLDC 5001 Eisenhower Avenue Alexandria, VA 22333	1	Commander CECOM R&D Technical Library ATTN: AMSEL-IM-L (Reports Section) Bldg. 2700 Fort Monmouth, NJ 07703-5000
1	Commander US Army Laboratory Command ATTN: AMSLC-TD, Richard Vitali 2800 Powder Mill Road Adelphi, MD 20783-1145	1	President US Army Aviation Test Board ATTN: ATZQ-OP-AA Ft. Rucker, AL 36360
1	Commander US Army Materiel Command ATTN: AMCDRA-ST, R. Haley 5001 Eisenhower Avenue Alexandria, VA 22333-0001	1	Commander US Army Communications - Electronics Command ATTN: AMSEL-ED Fort Monmouth, NJ 07703-5016
1	HQDA DAMA-ART-M Washington, DC 20310	1	Commander US Army Research Development & Engineering Center ATTN: AMSMI-RD Redstone Arsenal, AL 35898
1	HQDA ATTN: DAMA-ARZ-A, COL. J. Kempster Pentagon, Room 3-E-426 Washington, DC 20310-0632	1	Commander US Army Missile Command ATTN: AMSMI-RBL Redstone Arsenal, AL 35898
1	HQDA ATTN: DAMA-ARZ-A, COL. N. Cooney Pentagon, Room 3-E-426 Washington, DC 20310-0632	1	Commander US Army Missile Command ATTN: AMSMI-TLH Redstone Arsenal, AL 35898

1
2
3
4
5
6
7
8
9
10
11
12
13
14
15
16
17
18
19
20
21
22
23
24
25
26
27
28
29
30
31
32
33
34
35
36
37
38
39
40
41
42
43
44
45
46
47
48
49
50
51
52
53
54
55
56
57
58
59
60
61
62
63
64
65
66
67
68
69
70
71
72
73
74
75
76
77
78
79
80
81
82
83
84
85
86
87
88
89
90
91
92
93
94
95
96
97
98
99
100

DISTRIBUTION LIST

<u>No. of Copies</u>	<u>Organization</u>	<u>No. of Copies</u>	<u>Organization</u>
1	Commander US Army Missile Command ATTN: AMSMI-RDK Redstone Arsenal, AL 35898-5249	1	Project Manager Tank Maintenance Armament Systems ATTN: AMCPM-TM-A, Harvey Yuen H. Kossier W. Lang Dover, NJ 07801-5001
1	Director US Army Missile & Space Intelligence Center ATTN: AIAMS-YDL Redstone Arsenal, AL 35898-5500	1	Commander US Army Development and Employment Agency ATTN: MODE-TED-SAB Fort Lewis, WA 98433
1	Commander US Army Tank Automotive Command ATTN: AMSTA-TSL Warren, MI 48397-5000	1	Commander Armament RD&E Center US Army AMCCOM ATTN: SMCAR-TDC Dover, NJ 07801
1	Commander US Army Operational Test and Evaluation Agency ATTN: CSTE-ZS 5600 Columbia Pike Falls Church, VA 22041	1	LT COL Alexander Lancaster Tactical Technology Office Defense Advanced Research Projects Agency 1400 Wilson Boulevard Arlington, VA 22209
1	Commander US Army Armament Munitions & Chemical Command ATTN: AMSMC-IMP-L Rock Island, IL 61299-7300	1	ODCSI, USAREUR / 7A ATTN: AEAGB-PDN(S&E) APO, NY 09403
10	Commander US Army ARDEC ATTN: SMCAR-MSI SMCAR-TDC SMCAR-TDS, Mr. Lindner SMCAR-LC-F, Mr. Loeb SMCAR-LCW, Mr. Salsbury SMCAR-LCW, Mr. R. Wrenn SMCAR-SCA, Mr. Gehbauer SMCAR-LCU, Mr. Barrieres SMCAR-LC, T. Davidson Dover, NJ 07801-5001	4	Commander US AMCCOM ARDEC CCAC Benet Weapons Laboratory ATTN: SMCAR-LCB-TL Dr. T. Simkins Dr. G. Carofano Dr. C. Andrade Watervliet, NY 12189-4050
1	Project Manager Tank Maintenance Armament Systems ATTN: PM 105 Systems Dover, NJ 07801-5001	1	Commander US Army Materials Technology Laboratory ATTN: SLCMR-ATL Watertown, MA 02172

DISTRIBUTION LIST

<u>No. of Copies</u>	<u>Organization</u>	<u>No. of Copies</u>	<u>Organization</u>
1	Commander US Army Natick Research and Development Laboratory ATTN: AMDNA, Dr. D. Sieling Natick, MA 01760	1	Commander Naval Weapons Center ATTN: Dr. Klaus Schadow Code 3892 China Lake, CA 93555
1	Director US Army TRADOC Analysis Center ATTN: ATOR-TSL White Sands Missile Range, NM 88002-5502	2	Commander David W. Taylor Naval Ship Research & Development Ctr ATTN: Lib Div, Code 522 Aerodynamic Lab Bethesda, MD 20084
1	Commandant US Army Infantry School ATTN: ATSH-CD-CS-OR Ft. Benning, GA 31905-5400	2	Commander Naval Surface Weapons Center ATTN: 6X Dr. J. Yagla Dr. G. Moore Dahlgren, VA 22448
1	Commander US Army Development and Employment Agency ATTN: MODE-ORO Fort Lewis, WA 98433-5000	1	Commander Naval Surface Weapons Center ATTN: Code 730 Silver Spring, MD 20910
1	Commander US Army Research Office ATTN: CRD-AA-EH P.O. Box 12211 Research Triangle Park, NC 27709-2211	1	Commander Naval Weapons Center ATTN: Code 3433, Tech Lib China Lake, CA 93555
1	President US Army Armor and Engineer Board ATTN: ATZK-AE-PD, Mr. W. Wells Ft. Knox, KY 40121	1	Commander Naval Ordnance Station ATTN: Code FS13A, P. Sewell Indian Head, MD 20640
1	Commander Naval Air Systems Command ATTN: AIR-604 Washington, DC 20360	1	AFWL/SUL Kirtland AFB, NM 87117
1	Commander Naval Sea Systems Cmd ATTN: 003 Washington, DC 20362	1	AFATL/DOIL (Tech Info Center) Eglin AFB, FL 32542-5000
		1	ASD/XRA (Stinfo) Wright-Patterson AFB, OH 45433

1
2
3
4
5
6
7
8
9
10
11
12
13
14
15
16
17
18
19
20
21
22
23
24
25
26
27
28
29
30
31
32
33
34
35
36
37
38
39
40
41
42
43
44
45
46
47
48
49
50
51
52
53
54
55
56
57
58
59
60
61
62
63
64
65
66
67
68
69
70
71
72
73
74
75
76
77
78
79
80
81
82
83
84
85
86
87
88
89
90
91
92
93
94
95
96
97
98
99
100

DISTRIBUTION LIST

<u>No. of Copies</u>	<u>Organization</u>	<u>No. of Copies</u>	<u>Organization</u>
1	Director National Aeronautics and Space Administration George C. Marshall Space Flight Center ATTN: MS-I, Lib Huntsville, AL 38512	1	Aerospace Corporation ATTN: Dr. G. Widhopf Bldg. D8 M4/965 P.O. Box 92957 Los Angeles, CA 90009
1	NASA Langley Research Center ATTN: G. B. Northam Mail Stop 168 Hampton, VA 23665	1	AVCO Systems Division ATTN: Dr. D. Siegelman 201 Lowell Street Wilmington, MA 01887
1	Director Jet Propulsion Laboratory ATTN: Tech Lib 4800 Oak Grove Drive Pasadena, CA 91109	1	Technical Director Colt Firearms Corporation 150 Huyshope Avenue Hartford, CT 14061
1	Director NASA Scientific & Technical Information Facility ATTN: SAK/DL P.O. Box 8757 Baltimore/Washington International Airport, MD 21240	1	General Electric Armament & Electric Systems ATTN: Mr. R. Whyte Lakeside Avenue Burlington, VT 05401
1	AAI Corporation ATTN: Dr. T. Stastny P.O. Box 126 Cockeysville, MD 21030	2	Honeywell, Inc. ATTN: Mail Station MN 112190, G. Stillely MN 50-2060, Mr. T. Melander 600 Second Street, North East Hopkins, MN 55343
1	Advanced Technology Labs ATTN: Mr. J. Erdos Merrick & Steward Avenues Westbury, NY 11590	1	Hughes Helicopter Company Bldg. 2, MST22B ATTN: Mr. R. Forker Centinela and Teale Streets Culver City, CA 90230
2	United Technologies/Chemical Systems ATTN: Dr. Richard MacLaren Mr. Allen Holzman P.O. Box 50015 San Jose, CA 95150-0015	1	Martin Marietta Aerospace ATTN: Mr. A. J. Culotta P.O. Box 5837 Orlando, FL 32805
1	Science Applications, International Corporation ATTN: Dr. Raymond Edleman 9760 Gwensmouth Avenue Chatworth, CA 91311	1	AEROJET Ordnance Company ATTN: Mr. A. Flatau 2521 Michelle Drive Tustin, CA 92680

DISTRIBUTION LIST

<u>No. of Copies</u>	<u>Organization</u>	<u>No. of Copies</u>	<u>Organization</u>
1	S.K. Martini, Tech Reports Center Olin Corp. Research Center 350 Knotter Drive Cheshire, CT 06410-0586	1	Polytechnic Institute of New York Graduate Center ATTN: Tech Lib Route 110 Farmingdale, NY 11735
1	Director Sandia National Laboratory ATTN: Aerodynamics Dept Org 5620, R. Maydew Albuquerque, NM 87115	2	Loral Corporation ATTN: S. Schmotolocha Ben Axley 300 N. Halstead St. P.O. Box 7101 Pasadena, CA 91109
1	Guggenheim Aeronautical Lab California Institute of Tech ATTN: Tech Lib Pasadena, CA 91104	1	Director Forrestal Research Center Princeton University Princeton, NJ 08540
1	Franklin Institute ATTN: Tech Lib Race & 20th Streets Philadelphia, PA 19103	1	Kaman Tempo ATTN: Mr. J. Hindes 816 State Street P.O. Drawer QQ Santa Barbara, CA 93102
1	Director Applied Physics Laboratory The Johns Hopkins University Johns Hopkins Road Laurel, MD 20707	1	Southwest Research Institute ATTN: Mr. Peter S. Westine P.O. Drawer 28510 8500 Culebra Road San Antonio, TX 78228
1	Massachusetts Institute of Technology Dept of Aeronautics and Astronautics ATTN: Tech Lib 77 Massachusetts Avenue Cambridge, MA 02139	1	Boeing Corporation ATTN: C. R. Pond MS 8C-64 PO Box 3999 Seattle, WA 98124
1	Ohio State University Dept of Aeronautics and Astronautical Engineering ATTN: Tech Lib Columbus, OH 43210	1	General Defense Corporation Flinchbaugh Division ATTN: Mr. Edwin Steiner 200 East High Street P.O. Box 127 Red Lion, PA 17356
1	Arizona State University ATTN: Dr. R. M. C. So Tempe, Arizona 85281	1	FMC Corporation Northern Ordnance Division ATTN: Scott Langlie, Advanced Techniques 4800 East River Road Minneapolis MN 55421

DISTRIBUTION LIST

<u>No. of Copies</u>	<u>Organization</u>
10	C.I.A. OIR/DB/Standard GE-47 HQ Washington, D.C. 20505

Aberdeen Proving Ground

Dir, USAMSAA
ATTN: AMXSY-D
AMXSY-MP, H. Cohen

Cdr, USATECOM
ATTN: AMSTE-SI-F

Cdr, CRDC, AMCCOM
ATTN: SMCCR-RSP-A
SMCCR-MU
SMCCR-SPS-IL

Dir, USAHEL
ATTN: Dr. Weisz
Dr. Cummings
Mr. Garinther

Dir, USACSTA
ATTN: Mr. S. Walton

USER EVALUATION SHEET/CHANGE OF ADDRESS

This Laboratory undertakes a continuing effort to improve the quality of the reports it publishes. Your comments/answers to the items/questions below will aid us in our efforts.

1. BRL Report Number _____ Date of Report _____

2. Date Report Received _____

3. Does this report satisfy a need? (Comment on purpose, related project, or other area of interest for which the report will be used.) _____

4. How specifically, is the report being used? (Information source, design data, procedure, source of ideas, etc.) _____

5. Has the information in this report led to any quantitative savings as far as man-hours or dollars saved, operating costs avoided or efficiencies achieved, etc? If so, please elaborate. _____

6. General Comments. What do you think should be changed to improve future reports? (Indicate changes to organization, technical content, format, etc.) _____

CURRENT
ADDRESS

Name

Organization

Address

City, State, Zip

7. If indicating a Change of Address or Address Correction, please provide the New or Correct Address in Block 6 above and the Old or Incorrect address below.

OLD
ADDRESS

Name

Organization

Address

City, State, Zip

(Remove this sheet along the perforation, fold as indicated, staple or tape closed, and mail.)

END

6-87

DTIC